



Cost Analysis of HRVOC
Controls on Polymer Plants and
Flares
Project 2008-104
Work Order 582-07-84005-FY08-12

Prepared for:
Texas Commission on Environmental Quality
Austin, Texas

Prepared by:
ENVIRON International Corporation
Houston, Texas

Date:
August 2008

Project Number:
06-17477L

Contents

	Page
Executive Summary	1
1 Introduction	3
1.1 Project Purpose.....	3
1.2 Project Scope.....	3
1.3 Project Methodology	6
2 Background Information	7
2.1 Emissions from Polymer Production Processes.....	7
2.2 Special Inventory of HRVOC Emissions.....	8
2.2.1 HECT Allowance Allocations	10
2.3 TCEQ Guidance for Controlling Emissions from Polymer Plants.....	11
3 Catalog of Potential Control Technologies	12
3.1 Overview	12
3.2 Process Changes.....	12
3.3 Changes in Operating Procedures	12
3.3.1 Enhanced Maintenance	13
3.3.2 Dynamic Process Simulation	14
3.4 Vent Stream Controls.....	15
3.4.1 Flaring	16
3.4.2 Thermal Oxidation.....	17
3.4.3 Catalytic Oxidation	19
3.4.4 Boilers and Process Heaters	20
3.4.5 Bekaert Burners	22
3.4.6 Stripping	23
3.4.7 Adsorption / Concentration	23
3.4.8 Biofiltration / Bioscrubbing	25
3.4.9 Refrigerated Condensers.....	25
3.4.10 Non-Thermal Plasma	25
3.5 Flare Minimization.....	26
3.5.1 Recycling/Reuse	26
3.5.2 Flare Gas Recovery	27
4 Facility Survey Findings.....	29
4.1 Polymer Plant Questionnaire Results	29
4.1.1 Process Types Surveyed.....	29
4.1.2 Process Vent Control Techniques	30
4.1.3 Finishing Operations	31
4.1.4 HRVOC Emission Reduction Projects.....	31

4.1.5	Excess Monomer Removal	38
4.1.6	Costs of Polymer Plant HRVOC Emission Reduction Projects	39
4.2	Flare Questionnaire Results	40
4.2.1	Flare Inventory	40
4.2.2	Flare Reduction and Minimization Projects	41
4.2.3	Flare Gas Recovery	44
4.2.4	Costs of HRVOC Flare Reduction and Minimization Projects	44
4.3	Analysis	46
4.3.1	Types of Emission Reduction Projects	46
4.3.2	Cost Effectiveness of Emission Reduction Projects	47
4.3.3	Projects Not Undertaken	49
5	Conclusions & Recommendations	50
6	Project Team Contact Information	52

List of Tables

	Page
Table 1. Facilities that Received the Flare Questionnaire	4
Table 2. Facilities that Received the Polymer Production Questionnaire	5
Table 3. HRVOC Special Inventory Summary (Mass)	9
Table 4. HRVOC Special Inventory Summary (Percentage)	9
Table 5. Comparison of HRVOC Emissions and HECT Allowance Allocations.....	10
Table 6. Examples of Thermal Oxidation Used to Control HRVOC Emissions	19
Table 7. Examples of Boilers or Process Heaters Used to Control HRVOC Emissions	21
Table 8. Examples of Stripping Used to Control HRVOC Emissions.....	23
Table 9. Physical Properties of HRVOCs	24
Table 10. Summary of Process Vent Control Techniques by Process Type	30
Table 11. Summary of HRVOC Emission Reduction Projects.....	39
Table 12. Cost Effectiveness of HRVOC Emission Reduction Projects	39
Table 13. Summary of HRVOC Flare Reduction and Minimization Projects	41
Table 14. Cost Effectiveness of HRVOC Flare Reduction and Minimization Projects.....	45
Table 15. Summary of Project Type by Industry Sector	46
Table 16. Cost and Emission Reduction Summary by Plant	47

List of Figures

	Page
Figure 1. Simplified Polymer Process Flow Diagram	8
Figure 2. Typical Configuration – Regenerative Thermal Oxidizer	18
Figure 3. Typical Configuration – Recuperative Thermal Oxidizer	18
Figure 4. Typical Configuration – Catalytic Oxidizer.....	20
Figure 5. Bekaert Burners	22
Figure 6. Type and Number of Operational Polymer Process Units.....	30
Figure 7. Percent Average Flow and Number of Flares in HRVOC Service	41
Figure 8. Cost and Emission Reduction Summary by Plant.....	48
Figure 9. HRVOC Emission Reductions as a Function of Cost for Individual Projects	49

List of Appendices

Appendix A: Questionnaire Templates

List of Abbreviations

BACT:	Best Available Control Technology
Btu:	British Thermal Unit
DRE:	Destruction and Removal Efficiency
EPA:	United States Environmental Protection Agency
FGR:	Flare Gas Recovery
FTIR:	Fourier Transform Infrared
HARC:	Houston Advanced Research Center
HDPE:	High Density Polyethylene
HECT:	Highly Reactive Volatile Organic Compound Emissions Cap and Trade
HRVOC:	Highly Reactive Volatile Organic Compound
IR:	Infrared
LAER:	Lowest Achievable Emission Rate
LDPE:	Low Density Polyethylene
LLDPE:	Linear Low Density Polyethylene
M:	Thousand
MECT:	Mass Emission Cap and Trade
MM:	Million
NNSR:	Nonattainment New Source Review
NSR:	New Source Review
PE:	Polyethylene
PP:	Polypropylene
PSD:	Prevention of Significant Deterioration
ppm:	Parts per Million
ppmw:	Parts per Million by Weight
RACT:	Reasonably Available Control Technology
RN:	Regulated Entity Number
SBR:	Styrene-Butadiene Rubber
scf:	Standard Cubic Feet
scfm:	Standard Cubic Feet per Minute
TCEQ:	Texas Commission on Environmental Quality
tph:	Tons per Hour
tpy:	Tons per Year
VOC:	Volatile Organic Compound

Executive Summary

In June 2007, the TCEQ conducted a special emissions inventory, requesting highly reactive volatile organic compound (HRVOC) emissions data from those sources in Harris County, Texas, that are subject to HRVOC emissions cap-and-trade (HECT) program requirements. The results of the survey seemed to indicate that polymer production plants (e.g. polyethylene or polypropylene) are more likely than petroleum refineries, olefins plants, chemical plants, or independent storage terminals to have emissions that exceed their HECT allowance allocation. The TCEQ is evaluating what changes to the State Implementation Plan (SIP), if any, should be considered in light of these findings.

To support the SIP evaluation process, the TCEQ directed ENVIRON to collect and analyze information on projects undertaken to reduce emissions of HRVOC. Included in the investigation were HRVOC emission reduction projects undertaken by polymer manufacturing plants and HRVOC flaring reduction projects undertaken by polymer plants, olefins plants and petroleum refineries. To acquire the desired information, ENVIRON submitted 12 polymer plant questionnaires and 11 flare questionnaires to 16 HECT-affected sites in Harris County. All of these sites are currently subject to the requirements of the HRVOC emissions cap and trade (HECT) program.

Responding to the survey were sites that collectively included nine polymer production plants, four olefins manufacturing plants, and one petroleum refinery. These facilities provided information on 38 HRVOC emission reduction projects in three broad categories:

Changes in operating procedures: 17 projects

Vent gas Control: 7 projects

Flare minimization: 14 projects

Key project findings are as follows:

1. The 30 projects implemented at the nine polymer plant respondents resulted in a collective reduction in HRVOC emissions of approximately 346 tons per year at an average cost of \$14,774 per ton controlled.
2. The six flare reduction projects undertaken at the four respondent olefins plants resulted in a collective reduction in HRVOC emissions of approximately 243 tons/year at an average cost of \$5,295 per ton controlled.
3. Without additional information, it cannot be determined if polymer plants undertook more or fewer projects or if the cost effectiveness of those projects was higher or lower than those projects undertaken by other types of facilities.
4. Determining whether additional controls to further reduce HRVOC emissions at polymer plants would be cost effective is most properly done on a case-by-case basis. No

control technologies were identified that could be universally applied to achieve further reductions in HRVOC emissions from polymer plants in a cost-effective manner.

5. Use of flares is by far the most common method for controlling emissions of HRVOC. Most of the flares used to control routine emissions of HRVOC are designed to handle the very large flow rates that may occur during MSS and emission events – “emergency flares.” For the facilities that responded to this survey, average flows were approximately 4.4% of flare design capacity. However, the range was from less than 0.0001% to 38%.
6. While not the focus of this investigation, it was determined during the conduct of this study that polymer production units employing different processes (e.g. gas-phase vs. liquid-phase slurry) may have very different emission profiles even though they are manufacturing a similar product (e.g. polyethylene). It was also determined that making changes to the type of process used to manufacture a product may require an investment on the order of replacing the entire production unit. No facility surveyed undertook a process change to reduce HRVOC emissions.

1 Introduction

1.1 Project Purpose

The purpose of this project is for ENVIRON International Corporation (ENVIRON) to support the Texas Commission on Environmental Quality's (TCEQ) State Implementation Plan (SIP) development process by performing the following tasks:

- Identify control technologies that may be available to further reduce emissions of highly reactive volatile organic compounds (HRVOC) from polymer plants and from flares;
- Estimate potential costs for further controlling emissions of HRVOC from polymer manufacturing plants and from flares; and
- Collect cost information for measures that facilities have already undertaken to reduce HRVOC emissions.

This information may be used by the TCEQ to determine: 1) what additional control measures, if any, polymer production facilities could potentially implement to reduce emissions of HRVOC; 2) the cost effectiveness of potential additional HRVOC control measures; and 3) whether the TCEQ should consider reallocating the HRVOC emissions cap and trade (HECT) program allowances.

1.2 Project Scope

The scope of work includes the following tasks:

- Task 1. Develop work plan.
- Task 2. Prepare separate questionnaires for flare issues and polymer production issues to be sent to selected Harris County sites.
- Task 3. Develop draft interim report on list of potential control technologies for polymer processing and flare minimization.
- Task 4. Develop draft interim report on evaluation of potential control technologies for polymer processing and flare minimization.
- Task 5. Prepare final report.

For Task 2, ENVIRON prepared questionnaires for flare issues and polymer production issues that were sent to Harris County industrial facilities identified by the TCEQ. The questionnaire templates are included in Appendix A. The selected facilities are presented in Tables 1 (Flare Issues) and 2 (Polymer Production Issues).

Table 1. Facilities that Received the Flare Questionnaire				
Company Name	Site Name	Account	RN	Products
Basell USA Inc.	Basell USA Bayport Plant	HG0323M	RN100216761	Polypropylene
Chevron Phillips Chemical Company, L.P.	Chevron Cedar Bayou Chemical Plant	HG0310V	RN103919817	Ethylene, propylene, polyethylene, normal alpha olefins, poly alpha olefins
Chevron Phillips Chemical Company, L.P.	Chevron Phillips Pasadena Plastics Complex	HG0566H	RN102018322	Polyethylene, polypropylene, styrene-butadiene copolymer
Equistar Chemicals LP	Equistar Chemicals Channelview Complex	HG0033B	RN100542281	Ethylene, propylene, butadiene, benzene
Equistar Chemicals LP	Equistar Chemicals La Porte Complex	HG0770G	RN100210319	Ethylene, propylene, polyethylene, acetic acid, vinyl acetate monomer
Exxon Mobil Corporation	Exxon Mobil Baytown Facility	HG0232Q	RN102579307	Fuels, refined petroleum products, chemical feedstocks
ExxonMobil Chemical Company	ExxonMobil Chemical Baytown Chemical Plant	HG0229F	RN102574803	Polypropylene, isobutylene, benzene, xylenes, butyl polymers, normal paraffins
Exxon Mobil Corporation	ExxonMobil Chemical Baytown Olefins Plant	HG0228H	RN102212925	Ethylene, propylene, 1,3-butadiene
Shell Deer Park Refining Company	Shell Oil Deer Park	HG0659W	RN100211879	Ethylene, propylene, butylenes, isoprene, 1,3-butadiene, benzene, toluene, xylene
Total Petrochemicals USA	Total Petrochemicals La Porte Plant	HG0036S	RN100212109	Polypropylene
Total Petrochemicals USA	Total Petrochemicals Bayport Plant	HG4662F	RN100909373	Polyethylene

Table 2. Facilities that Received the Polymer Production Questionnaire				
Company Name	Site Name	Account	RN	Products
Basell USA Inc.	Basell USA Bayport Plant	HG0323M	RN100216761	Polypropylene
Chevron Phillips Chemical Company, L.P.	Chevron Cedar Bayou Chemical Plant	HG0310V	RN103919817	Ethylene, propylene, polyethylene, normal alpha olefins, poly alpha olefins
Chevron Phillips Chemical Company, L.P.	Chevron Phillips Pasadena Plastics Complex	HG0566H	RN102018322	Polyethylene, polypropylene, styrene-butadiene copolymer
Equistar Chemicals LP	Equistar Chemicals La Porte Complex	HG0770G	RN100210319	Ethylene, propylene, polyethylene, acetic acid, vinyl acetate monomer
ExxonMobil Chemical Company	ExxonMobil Chemical Baytown Chemical Plant	HG0229F	RN102574803	Polypropylene, isobutylene, benzene, xylenes, butyl polymers, normal paraffins
Innovene Polyethylene North America	BP Solvay Polyethylene NA	HG0665E	RN102537289	Polypropylene and olefins
Innovene Polymers, Inc.	Battleground Polyethylene Plant	HX2897U	RN100229905	Polyethylene and polypropylene
Sunoco Inc. (R&M)	Bayport Polyethylene Plant		RN103773206	Polyethylene
Sunoco Inc. (R&M)	Sunoco R&M Bayport Polypropylene		RN100524008	Polypropylene
Sunoco Inc. (R&M)	Sunoco La Porte Plant	HG0825G	RN102888328	Polypropylene
Total Petrochemicals USA	Total Petrochemicals La Porte Plant	HG0036S	RN100212109	Polypropylene
Total Petrochemicals USA	Total Petrochemicals Bayport Plant	HG4662F	RN100909373	Polyethylene

1.3 Project Methodology

This study is conducted in two phases. The first phase is to identify technologies that have been used, or may potentially be used, to control emissions of HRVOC from polymer plants. The findings from this phase of the work are presented in Section 3 of this report. The second phase is the identification of control options, and associated costs, that have been used to reduce:

1. HRVOC emissions from Harris County polymer plants, and
2. Flaring at polymer plants, olefins manufacturing plants, and petroleum refineries in Harris County.

The findings from this phase are presented in Section 4 of this report.

2 Background Information

2.1 Emissions from Polymer Production Processes

HRVOC compounds are used extensively in the manufacture of polymers.¹ Examples include:

- Use of ethylene in the manufacture of polyethylene (PE). PE is a thermoplastic (becomes soft when heated and hard when cooled) that is heavily used in consumer products (e.g. plastic shopping bags). PE is classified into a large number of categories based on its density and branching. Examples include high-density PE (HDPE), low-density PE (LDPE), and linear low-density PE (LLDPE).
- Use of propylene in the manufacture of polypropylene (PP). Like PE, PP is a thermoplastic that finds wide use in a variety of applications.
- Use of 1,3-butadiene in the manufacture of synthetic rubbers such as polybutadiene and styrene butadiene rubber (SBR). SBR is widely used in the manufacture of automobile tires.
- Use of butenes in the manufacture of synthetic rubbers such as polyisobutylene and as copolymers. A copolymer is a polymer derived from two or more monomers. An example is SBR which is derived from styrene and 1,3-butadiene.

Figure 1 presents a simplified process flow diagram for manufacturing polymer pellets.² For polymer products other than pellets, downstream operations may vary. For example, when manufacturing a polymer flake or powder, there will not be an extruder. Similarly, SBR is typically not extruded, but sold as SBR crumb.

Sources of HRVOC from a polymer manufacturing process may include one or more of the following:³

- Monomer or comonomer storage
- Process fugitives
- Cooling tower heat exchange system losses

¹ A polymer is a large molecule composed of repeating structural units. Examples include polyethylene and polypropylene.

² Technical Guidance for Chemical Sources: Polyethylene and Polypropylene Manufacturing, Draft RG-244, TCEQ Air Permits Division, February 2001.

³ Ibid

- Process vents upstream of the extruder (e.g. reactor, resin degassing)
- Extruder
- Polymer storage and loading
- Wastewater treatment facilities

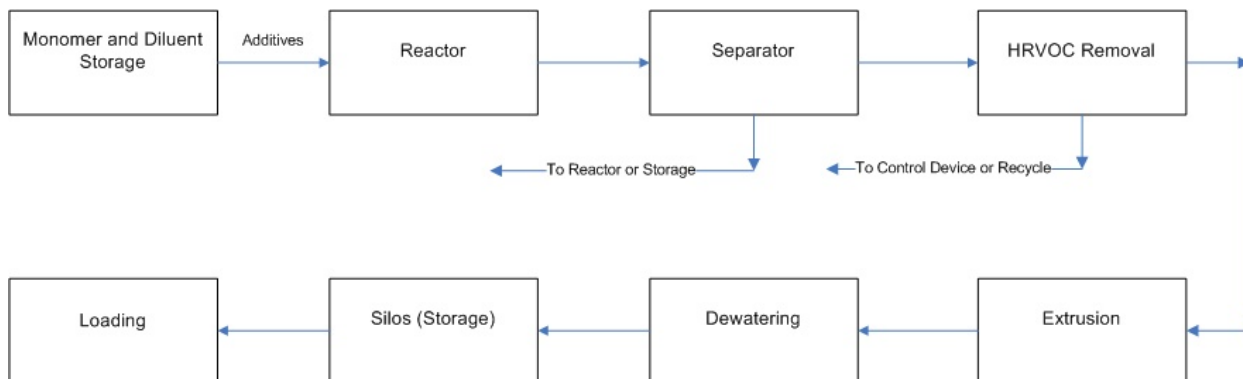

Figure 1. Simplified Polymer Process Flow Diagram

2.2 Special Inventory of HRVOC Emissions

In June 2007, the TCEQ conducted a special emissions inventory, requesting HRVOC emissions data from those sources in Harris County, Texas, that are subject to HRVOC emissions cap-and-trade (HECT) program requirements. The reporting period for this special inventory was February 1, 2006, through January 31, 2007.

Special inventory responses were categorized based upon the primary activity at the site:

- Chemical manufacturing (non-olefin, non-polymer)
- Olefins manufacturing⁴
- Polymer manufacturing
- Petroleum Refining
- Independent storage terminals (not dedicated to an individual refinery, olefins, chemical or polymer manufacturing site)

⁴ An "olefin," or alkene, is an unsaturated chemical compound containing at least one carbon-carbon double bond. The simplest olefin is ethylene which has the following chemical structure: $H_2C=CH_2$.

HRVOC special inventory responses are summarized in Tables 3 and 4. The values shown in Table 3 are total emissions for each industry sector. Emissions for the five industry sectors combined are shown in the far right column. The percentages presented in Table 4 are for total emissions reported by that industry sector. Percentages for the five combined sectors are presented in the far right column. Values presented in Tables 3 and 4 are taken from summaries provided by TCEQ personnel. ENVIRON has not reviewed the special inventory submittals nor validated the values provided.

Table 3. HRVOC Special Inventory Summary (Mass)

Source	Emissions by Industry Sector (tons)					
	Chemical ²	Olefins	Polymers	Refining	Terminal ²	Combined ²
Flares	278.3	376.7	460.0	308.7	45.8	1,469.5
Cooling Towers	35.4	18.1	20.9	88.1	0.1	162.6
Other Vents	97.5	157.1	221.1	125.0	1.7	602.4
Fugitives	19.6	115.5	22.0	26.0	0	183.1
Total ^{2,3}	443.2	667.4	724.1	547.8	50.9	2,433.4
Type						
MSS & Events	34.8	124.8	81.0	83.2	0.0	323.8
Uncontrolled ¹	136.4	245.3	234.0	135.9	1.8	753.4
Controlled ¹	259.5	297.3	409.0	328.8	45.9	1,340.5

¹ Uncontrolled and controlled routine emissions. MSS and event emissions are accounted for separately.
² Total includes emissions from sites that were not broken down by source or type of emissions.
³ Total includes fugitive emissions from equipments leaks which are not subject to HECT.

Table 4. HRVOC Special Inventory Summary (Percentage)

Source	Emissions by Industry Sector (%)					
	Chemical ¹	Olefins	Polymers	Refining	Terminals ¹	Combined
Flares	64.6	56.4	63.5	56.3	96.3	60.8
Cooling Towers	8.2	2.7	2.9	16.1	0.1	6.7
Other Vents	22.6	23.5	30.5	22.8	3.6	24.9
Fugitives	4.5	17.3	3.0	4.7	0.0	7.6
Type						
MSS & Events	8.1	18.7	11.2	15.2	0.0	13.4
Uncontrolled ²	31.7	36.8	32.3	24.8	3.8	31.2
Controlled ²	60.2	44.5	56.5	60.0	96.6	55.4

¹ Emissions (%) were determined using 430.8 tons as the total emissions for the Chemical sector and 47.6 tons as the total emissions for the Terminals sectors.
² Uncontrolled and controlled *routine* emissions. MSS and event emissions are accounted for separately.

As shown in Table 4, the information contained within the special inventory submittals indicate that approximately 61% of total reported HRVOC emissions are controlled using flares. This includes MSS and events that are controlled by flare. The 55.4% noted as “controlled” does not include MSS and events. Therefore, approximately 64% of routine emissions are controlled.

2.2.1 HECT Allowance Allocations

Under the HECT, allowances are allocated by the TCEQ to affected sites in Harris County according to the procedures defined by rule in 30 TAC §101.394. The initial allocation occurred January 1, 2007, with subsequent allocations occurring January 1 of each year thereafter. Covered facilities at these sites include flares, cooling tower heat exchange systems and vent gas streams. Fugitive emissions are not covered by the HECT.

On August 18, 2006, the TCEQ published a list of HECT allowance allocations. A total of 51 sites in Harris County were allocated 3,451.5 tons of HRVOC. Table 5 presents a comparison of HRVOC emissions reported as part of the special inventory, by industry sector, with the HECT allowance allocation for that sector. The allowance allocation shown is only for those facilities that reported emissions as part of the special HRVOC emissions inventory. Since all facilities with HECT allowance allocations did not respond to the special inventory request, the summation of allowance allocations does not equal the total number of allowances allocated (3,451.5 tons) but does account for over 98% of the allocations.

There are several sites that could be included in more than one industry sector. In those cases, the site is placed into the industry sector that seems to best represent their primary business. For example, a petroleum refinery with a collocated chemical plant will be included in the Refining Industry sector.

Industry Sector	HRVOC Emissions (tons)¹	Annual HECT Allowance Allocation (tons)	Emissions as a % of Allowance Allocation
Chemical	411.2	718.6	57.2
Olefins	551.9	1,123.8	49.1
Polymers	702.0	496.1	141.5
Refining	521.8	996.7	52.4
Terminals	47.6	57.0	83.5
Combined	2,234.5	3,392.2	65.9

¹ Total emissions from emission points covered by the HECT: flares, cooling towers and other vents. Fugitive emissions are not covered by the HECT. Does not include uncharacterized emissions from Chemical and Terminals sectors.

As shown in Table 5, during the period covered by the special inventory, polymer production plants were more likely than petroleum refineries, olefins plants, chemical plants, or independent storage terminals to have emissions that exceed their HECT allowance allocation.

2.3 TCEQ Guidance for Controlling Emissions from Polymer Plants

Prior to developing a catalog of potential control strategies that may be available for further reducing emissions of HRVOC from polymer plants, ENVIRON first reviewed previous TCEQ guidance on the subject. TCEQ guidance issued in February 2001 by the Air Permits Division provides the following regarding control of emissions from PE and PP manufacturing facilities undergoing New Source Review (NSR) permitting.⁵

- Best Available Control Technology (BACT) for all types of processes requires control of all waste gas streams upstream of the extruder.
- Control devices specified by guidance are as follows:
 - For vent streams, combustion using a flare, incinerator, boiler, heater, etc.
 - For fugitive emissions, a 28 VHP fugitive monitoring program.⁶
- Maximum allowable residual volatile organic compound (VOC) – which for PE and PP manufacturing facilities would be all HRVOC – in the polymer at the first uncontrolled vent should be less than 90 parts per million by weight (ppmw) for all manufacturing processes with the exception of high-pressure polyethylene manufacturing processes where guidance states a limit of 100 ppmw.
- Total non-fugitive VOC emissions, including HRVOC emissions, should generally be less than 200 pounds per million pounds (MM lb) of product.

The most recent published TCEQ guidance on BACT for PE and PP production facilities (October 17, 2006), is more restrictive than the 2001 technical guidance document. Specifically, it requires that total non-fugitive, uncontrolled VOC (including HRVOC) emissions are to be reduced to less than 80 pounds per MM lb of PE or PP produced.⁷

It should be noted that HRVOC fugitive monitoring requirements for affected facilities under 30 TAC Subpart H, Division 3, is more stringent than the requirements of 28 VHP.

⁵ Technical Guidance for Chemical Sources: Polyethylene and Polypropylene Manufacturing, Draft RG-244.

⁶ The revised requirements of 28 VHP are specified in TCEQ guidance issued in May 2008:
http://www.tceq.state.tx.us/assets/public/permitting/air/Guidance/NewSourceReview/rev28vhp_508.pdf

⁷ TCEQ Chemical Sources, Current Best Available Control Technology (BACT) Requirements, Polyethylene and Polypropylene Facilities, October 2006.
http://www.tceq.state.tx.us/assets/public/permitting/air/Guidance/NewSourceReview/bact/bact_polys.pdf

3 Catalog of Potential Control Technologies

3.1 Overview

Methods identified for potentially reducing HRVOC emissions include:

- Process changes,
- Changes in operating procedures,
- Vent stream controls, and
- Flare minimization.

Each of these is discussed in turn within this section.

3.2 Process Changes

For existing production facilities, short of replacing older technology with newer technology, there are limited opportunities for making process changes that reduce HRVOC emissions. One of these limited opportunities discussed in a 1997 EPA document on the polymer industry is changing catalysts.⁸ This document suggests that there are opportunities to replace an older catalyst with a newer, better catalyst, resulting in overall yield improvements, and, thus, reducing the amount of un-reacted monomer that remains in the polymer. This information is somewhat misleading. A polymer manufacturing facility must use a catalyst that is most appropriate for their process and the polymer properties sought.

For example, a gas phase PE reactor may use an older catalyst that has lower reactivity and selectivity than a newer, better catalyst. However, the newer, better catalyst may not be suitable for use in the gas phase reactor, but can only be used in a high pressure slurry PE process. Additionally, use of the old catalyst may be necessary to produce the desired PE properties.

3.3 Changes in Operating Procedures

As with process changes, there may be opportunities to modify operating procedures to reduce emissions of HRVOC. Potential changes in operating procedures may range from enhanced maintenance activities to the use of sophisticated dynamic simulation algorithms to reduce losses during non-steady state operating conditions, such as those that occur during startup and shutdown.

⁸ Profile of the Plastic Resin and Manmade Fiber Industries, Sector Notebook Project, EPA-310/R-97-006, September 1997.

3.3.1 Enhanced Maintenance

There may be opportunities to improve maintenance of existing equipment and reduce losses of HRVOC during normal operations and/or scheduled maintenance activities. Examples of enhanced maintenance activities may include more aggressive investigation and timely corrective action of leaking pressure safety valves (PSV), leaking compressor seals, leaking valves and flanges, leaking heat exchangers, etc. However, sites subject to the HECT are already required to monitor cooling tower return lines for leaking heat exchange systems and implement stringent fugitive monitoring and control requirements.⁹ [As noted previously, fugitive emissions are not included in the HECT.]

Enhanced maintenance may also include use of predictive and preventive maintenance processes. The predictive maintenance process involves review of the equipment types, the failure mechanisms associated with those equipment types and the associated mean time to failure. Preventive maintenance takes the next step and focuses maintenance on taking action before equipment fails. This preventive maintenance can lead to higher reliability, greater on-stream time, and fewer unscheduled maintenance shutdowns.

Required HRVOC monitoring of flare headers and cooling tower returns has resulted in some subject facilities implementing enhanced maintenance programs.¹⁰ For example, one site uses the HRVOC monitoring system as a feedback mechanism. When flaring, operators use the HRVOC monitoring system to help identify the source of the flows (e.g., PSV leaks, open valves). The monitors do not identify specific equipment, but the ability to speciate the compounds going to the flare helps to narrow troubleshooting efforts to a particular process area.

Some sites are also using passive infrared (IR) cameras to find and eliminate/reduce emissions of HRVOC. As part of the HARC H-76 project, ENVIRON found that, as of the summer of 2006, three of the nine surveyed sites were using the IR cameras to locate potential sources of HRVOC emissions.¹¹ Uses of the IR cameras include:

- Integration of IR cameras into routine leak detection and repair (LDAR) programs.
- Use of IR cameras to monitor for emissions during startup and shutdown. Camera findings are used to direct corrective measures.

⁹ Any process unit or process within a petroleum refinery, synthetic organic chemical, polymer, resin, or methyl tert-butyl ether manufacturing process or natural gas/gasoline processing operation in the 8-county Houston/Galveston/Brazoria area in which an HRVOC is a raw material, intermediate, final product, or in a waste stream is subject to the requirements of 30 TAC 115, Subchapter H, Division 3 which specifies monitoring and control requirements for fugitive emissions from equipment.

¹⁰ "How Chemical Manufacturing and Petroleum Refining Facilities in Harris County are Using Point Source Monitoring to Identify and Reduce HRVOC Emissions," HARC Project H76, ENVIRON, prepared for the Houston Advanced Research Center, October 2006.

¹¹ Ibid

As discussed in the Project H-76 report, those companies that have embraced use of the passive IR cameras are strong supporters of using this technology to find and fix sources of emissions.

As part of an agreement with the City of Houston, one facility in Harris County has installed a fence line Fourier Transform Infrared (FTIR) monitoring system to monitor for 1,3-butadiene.¹² While not initially intended as a tool for improving maintenance or operating practices, the fence line FTIR system has allowed the facility to identify operations and activities that result in emissions of 1,3-butadiene and to use that information in taking corrective action.

3.3.2 Dynamic Process Simulation

Understanding how operating conditions affect waste gas production can lead to improved operating techniques. Rather than relying solely on engineering trial-and-error and operator experience to modify operating procedures to minimize flaring, dynamic process simulation has been used to minimize HRVOC flaring during shutdown and startup at an ethylene production facility.¹³ In the referenced study performed by Lamar University in cooperation with LyondellBasell's Equistar Channelview Plant, dynamic process simulation was used to critically evaluate potential process and procedural modifications prior to the actual shutdown/startup or upset event. Dynamic simulation was developed for the recovery section of the ethylene plant and used to examine the following process steps:

- Approaching shutdown,
- Startup with recycle ethane, and
- Starting the cracked feed and increasing the feed to normal production rates.

The researchers found that dynamic process simulation provides an insight into process behavior that is not readily apparent through steady state simulation and process engineering calculations. Process simulations are performed using standard software, such as Aspen Plus and Aspen Dynamics™. Operators can use the results of the dynamic process simulations to modify control settings during shutdown/startup and upset conditions to minimize flaring of off-specification (off-spec) streams.

Results of the Equistar Channelview Plant dynamic process simulation study are as follows:¹⁴

- Actual flaring associated with shutdown and startup of the ethylene plant was 75% less than a previous startup of a similar plant at the site.

¹² Ibid

¹³ Flare Minimization via Dynamic Simulation. Singh, A., K. Li, H. H. Lou, J. R. Hopper, H. B. Golwala and S. Ghumare. *Int. J. Environment and Pollution*. Vol. 29, Nos. 1/2/3, pp. 19-29.

¹⁴ Ibid

- Flaring emissions from the shutdown and startup were 56% less than the estimates made prior to the turnaround.

Using dynamic process simulation, other ethylene production facilities have reduced HRVOC emissions from flaring. Examples include:

- Huntsman Petrochemical reduced flaring to less than 3.5 hours during a startup event, and
- BASF-TOTAL reduced flaring by 50% compared to a previous startup.¹⁵

This project has not determined if dynamic process simulation can be applied to polymer manufacturing plants.

3.4 Vent Stream Controls

Based on our review of EPA's RACT/BACT/LAER Clearinghouse (RBLC), ENVIRON identifies three technologies that have been used to control HRVOC emissions from process vents at polymer manufacturing plants: flares, thermal oxidizers and boilers. Additionally, while not an ultimate control device, air and steam stripping have been used to remove un-reacted monomer from SBR crumb prior to finishing. While not identified in the RBLC review, ENVIRON is aware that polymer plant waste gas streams containing HRVOC have also been managed using catalytic oxidizers. Each of these technologies is briefly described within this section. Also included are brief discussions of other control technologies considered: adsorption, biofiltration, Bekaert burners and refrigerated condensers.

It is important to keep in mind that the technical feasibility, including process safety considerations, and economic feasibility of any control system can only be determined on a case-by-case basis.

Costs are not included within these general discussions of control technologies. Costs of control are highly dependent upon a number of design and operating variables and often cannot be estimated accurately within even one or two orders of magnitude without specific information as to the application. For example, USEPA Air Pollution Control Technology Fact Sheet EPA-452/F-03-019 provides the following range of costs for flares.

Capital Cost:\$13 to \$21,000 per standard cubic foot per minute (scfm)
of flow

Operation & Maintenance Cost:\$1 to \$10 per scfm

Annualized Cost:\$3 to \$300 per scfm

¹⁵ Near-Zero Flare for Chemical Process Industry via Plant-wide Optimization and Simulation. Xu, Q., K. Li and J. L. Gossage. TERC SAC Meeting, Houston, Texas. February 2008.

Cost Effectiveness: \$15 to \$5,000 cost per ton of pollutant controlled

It is questionable if even this very broad range brackets actual costs that might be incurred for flaring of one or more process vent streams. Meaningful control costs can only be determined on a case-by-case basis.

3.4.1 Flaring

Flaring is a combustion control process in which the combustible material to be flared is piped to a remote, usually elevated location, and burned in an open flame in the air using a specially designed burner tip, auxiliary fuel, and steam or air to promote mixing for nearly complete (>98%) destruction efficiency. Completeness of combustion in a flare is governed by flame temperature, residence time in the combustion zone, turbulent mixing of the gas stream components to complete the oxidation reaction, and available oxygen for free radical formation.¹⁶

Flares that conform to the design requirements of 40 CFR 60.18 are assumed by rule to achieve 98% destruction efficiency for C4 HRVOCs (1,3-butadiene and butenes) and 99% destruction efficiency for C2-C3 HRVOCs (ethylene and propylene).¹⁷ The design requirements of 40 CFR 60.18 include the following:

- Flame present at all times.
- Minimum net heating value of the gas being burned of 300 Btu/scf (steam or air-assisted) or 200 Btu/scf (non-assisted).
- Maximum exit velocity of 60 feet per second for steam-assisted or non-assisted flares. Velocity limits for air-assisted flares are dependent upon the net heating value of the gas being combusted.

Flares are commonly used to control HRVOC emissions at petroleum refineries, chemical plants, olefins manufacturing plants, polymer manufacturing plants and for-hire storage terminals. Review of the RBLC identified use of flaring to control emissions from product storage and product loading at the Chevron Phillips Chemical Company Pasadena Plastics Plant. The permit for this application was dated December 15, 1998.

Flaring of HRVOC emissions from extruders and finishing operation vent streams has been limited for a number of reasons, including: cost of capture (e.g. installation of hooding on extruders, etc.), cost of supplemental fuel, and safety (air in flare header resulting in a potentially explosive waste stream). To illustrate the cost of supplement fuel, assume a 1,000 standard cubic feet per minute vent stream containing 200 ppm ethylene – approximately 4

¹⁶ USEPA Air Pollution Control Technology Fact Sheet EPA-452/F-03-019

¹⁷ 30 TAC 115.725(d) contains several references to these control efficiencies.

tons/year – is routed to a flare for control. The heat value of the ethylene at this concentration is approximately 0.3 Btu/scf. To meet the 40 CFR 60.18 design requirement of 300 Btu/scf for a steam-assisted flare, this vent stream will either need to be combined with a higher heat content vent stream prior to flaring or supplemented with a fuel, such as natural gas. If a supplementary fuel is used, approximately 429 scfm of natural gas will need to be added to the vent stream to raise the heat content to 300 Btu/scf. On an annual basis, this equates to approximately 225.5 million scf (MMscf). Assuming a natural gas price of \$9.00 per MMBtu, supplemental fuel for flaring this 1,000 scfm vent gas stream will cost approximately \$2,000,000 per year. The incremental cost of control for this vent stream using a flare, just considering the cost of the supplemental fuel, is approximately \$500,000 per ton. This cost of control would apply to any 200 ppm ethylene vent stream that is flared. Additionally, the use of supplemental fuel would result in additional CO and NO_x emissions from the flare.

3.4.2 Thermal Oxidation

There are two general types of thermal oxidizers (TO) in common use: regenerative and recuperative. A regenerative thermal oxidizer, or RTO, uses a high-density media such as a ceramic packed bed still hot from a previous cycle to preheat an incoming waste gas stream. The preheated waste gases then enter a combustion chamber where they are heated by auxiliary fuel combustion (e.g. natural gas) to a final oxidation temperature typically between 1,400 and 1,500°F. The hot exit gases are directed to one or more ceramic packed beds where the heat from the gases is absorbed before they are vented to the atmosphere. An RTO will typically achieve a control efficiency of 95 to 99%.¹⁸

Recuperative TOs are comprised of the combustion chamber, waste gas preheater and, if appropriate, a secondary energy recovery preheater. Recuperative TOs can recover up to 70% of the waste heat from the exhaust gases and achieve destruction efficiencies ranging from 98% to as high as 99.9999%.¹⁹

The typical design conditions required to achieve at least 98% destruction efficiency in a recuperative TO are:

- Minimum combustion temperature of 1,600°F,
- Combustion chamber residence time of 0.75 second, and
- Proper mixing.

¹⁸ USEPA Air Pollution Control Technology Fact Sheet EPA-452/F-03-021

¹⁹ USEPA Air Pollution Control Technology Fact Sheet EPA-452/F-03-020

Figures 2 and 3 present typical configurations for regenerative and recuperative TOs, respectively.²⁰

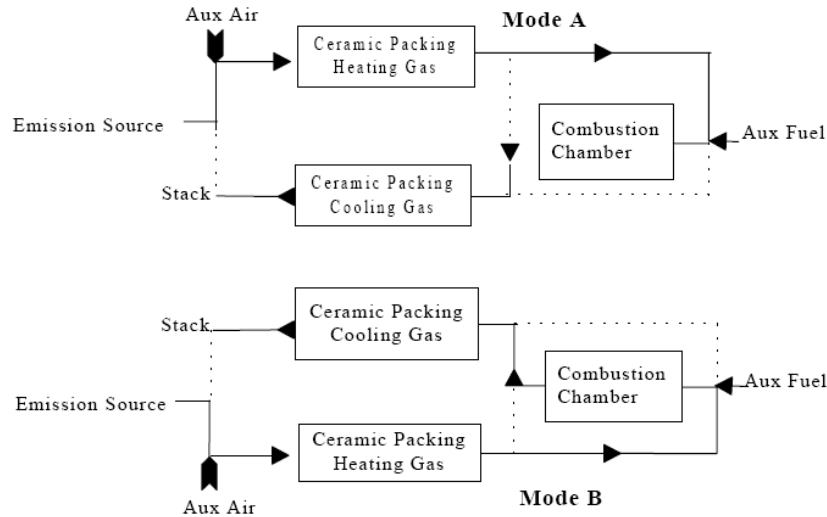

Figure 2. Typical Configuration – Regenerative Thermal Oxidizer

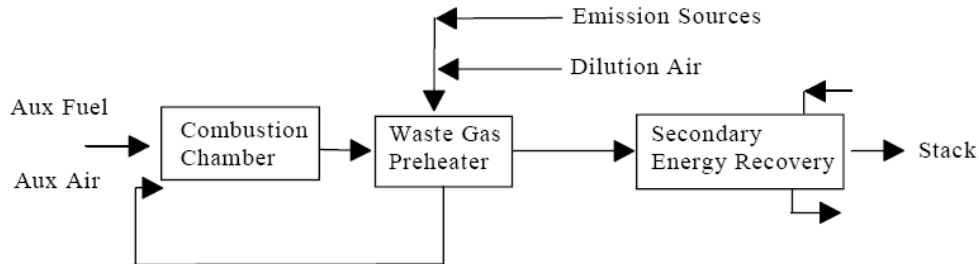

Figure 3. Typical Configuration – Recuperative Thermal Oxidizer

Table 6 summarizes the findings of the RBL review (last 10 years) with respect to control of HRVOC emissions from polymer plants using thermal oxidation. This listing is not comprehensive. Sources that did not undergo federal NSR, either Prevention of Significant Deterioration (PSD) or Nonattainment NSR (NNSR), will not be listed in the RBL.

²⁰ USEPA Air Pollution Cost Control Manual, 6th Edition, EPA-452/B-02-001, January 2002

Table 6. Examples of Thermal Oxidation Used to Control HRVOC Emissions

Company:	Fagerdala Pac-Lite Incorporated
Location:	St. Clair, Michigan
Permit Date:	02/01/2001
Process Description:	Expandable polypropylene bead production.
Control Application:	Emissions from the fluidized bead dryer and regrind extruder are controlled by thermal oxidizer. Die area is hooded.
Control Efficiency:	85%
Company:	Formosa Plastics Corporation
Location:	Point Comfort, Texas
Permit Date:	03/09/1999
Process Description:	Polypropylene plant with multiple trains with two reactors each.
Control Application:	Process off-gases are routed to incinerator. Reactor gases are routed to flare header in case of an upset.
Control Efficiency:	Unknown. HRVOC emissions are limited to 31.5 lb/MMlb for Train 4, 133 lb/MMlb for Trains 1-3.
Company:	Total Petrochemicals USA (formerly Atofina Petrochemicals Inc.)
Location:	La Porte, Texas
Permit Date:	11/05/2001
Process Description:	Polypropylene production
Control Application:	Backup thermal oxidizer. Areas of process controlled are not identified.
Control Efficiency:	99.99%
Company:	Goodyear Tire and Rubber Company
Location:	Beaumont, Texas
Permit Date:	02/19/2004
Process Description:	Styrene butadiene rubber production
Control Application:	Regenerative thermal oxidizer. Application is unspecified.
Control Efficiency:	Not specified

3.4.3 Catalytic Oxidation

Catalytic oxidizers operate similar to thermal oxidizers with the primary difference being that, after passing through the flame zone, the waste gases pass through a catalyst bed. The catalyst has the effect of increasing the reaction rate, enabling oxidation of the organics in the waste stream at a lower reaction temperature than would be required in a thermal oxidizer to achieve the same destruction efficiency. Catalysts also allow for a reduced residence time and, thus, allow for smaller oxidizers. The waste gas is typically heated to between 600°F and 800°F

before entering the catalyst. Control efficiencies as high as 95-99% can be achieved with catalytic oxidation.²¹

Catalytic oxidizers are subject to plugging as well as catalyst deactivation or poisoning. Therefore, they are not as widely applicable as thermal oxidizers. As with any control approach, however, technical and economic feasibility can only be evaluated on a case-by-case basis.

Figure 4 presents a typical configuration for a catalytic oxidizer.²²

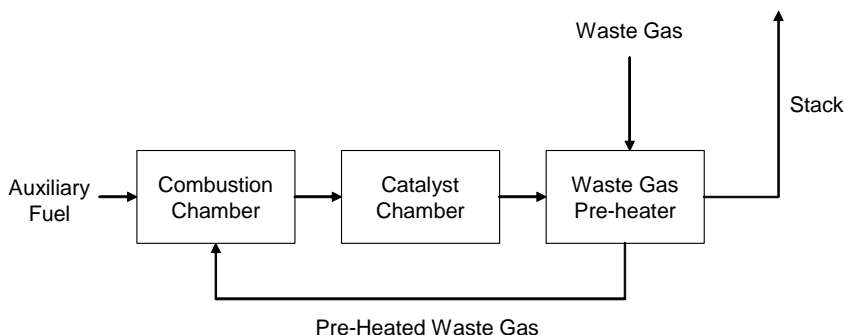

Figure 4. Typical Configuration –Catalytic Oxidizer

Review of the RBLC did not identify any application of catalytic oxidizers to control emissions of HRVOC from polymer plants in the last 10 years. However, as noted previously, this listing is not comprehensive. As discussed in Section 4 of this report, catalytic oxidizers have been used at sites in Harris County to control emissions of HRVOC.

3.4.4 Boilers and Process Heaters

Boilers and process heaters, under certain process conditions, may be used to combust waste streams containing HRVOC. Considerations in burning HRVOC waste gas streams in boilers and process heaters include the following:²³

- Most chemical plants, olefins manufacturing plants and polymer plants do not have fuel gas headers that facilitate collection of waste gases for use as fuels. This may limit or eliminate consideration of this control option.
- Boilers designed specifically for HRVOC control use discrete or vortex burners.²⁴

²¹ USEPA Air Pollution Control Technology Fact Sheet EPA-452/F-03-021

²² EPA Air Pollution Cost Manual, 6th Edition, EPA-452/B-02-001, January 2002

²³ Some of the items listed are derived from discussions with industry personnel.

²⁴ Polymer Manufacturing Industry, Background Information for Proposed Standards, EPA-450/3-83-019a, September

- Use of high concentration ethylene streams as a fuel tends to result in more nitrogen oxides (NO_x) formation than the burning of natural gas.²⁵
- The combustion characteristics of certain olefin derivatives, such as propylene oxide, make it unsuitable for combustion in boilers or process heaters because it combusts explosively. This characteristic could also limit the use of thermal or catalytic oxidizers.
- Olefins such as ethylene and propylene may polymerize in a fuel gas header, resulting in plugged lines with associated safety and performance implications.

While not common, there are examples of boilers being used to control emissions from polymer plants. In a 1985 document, EPA identifies two polypropylene plants and a high density polyethylene (HDPE) plant that route off-gases to a boiler for control.²⁶

In addition, ENVIRON identified one facility during review of the RBLC (last 10 years) that was permitted to use a boiler to control emissions of HRVOC from a polymer production facility (Table 7). Note that this listing is not comprehensive. Sources that did not undergo federal NSR, either PSD or NNSR, will not be listed in the RBLC.

Table 7. Examples of Boilers or Process Heaters Used to Control HRVOC Emissions	
Company:	Total Petrochemicals USA (formerly Atofina Petrochemicals Inc.)
Location:	La Porte, Texas
Permit Date:	11/05/2001
Process Description:	Polypropylene production
Control Application:	Waste heat boiler and regenerative gas heater. Areas of process controlled are not identified.
Control Efficiency:	99.99%

In addition to the application identified in Table 7, within the description for a project at the Chevron Phillips Chemical Company Pasadena, Texas, plant (permit date of 02/23/2000) is the following:

“The Phillips Chemical Company seeks authorization to use certain PE and PP process off gases as fuel at existing flares located within their Houston Chemical Complex. The process off gases are generated on-site at process units and were used as fuel at four on-site boilers;

1985.

²⁵ Ethylene has a high heat content: approximately 1,600 Btu/scf compared with approximately 1,000 Btu/scf for methane (natural gas). Consequently, unless specifically designed for burning ethylene, the combustion device will burn hotter and have higher NO_x emissions.

²⁶ EPA-450/3-83-019a

however, the boilers are being permanently shutdown . . . Certain PE/PP off gases will be routed to the flare fuel gas system for use as flare fuel gas.”

It is ENVIRON’s understanding that as part of their strategy for complying with the NO_x Mass Emission Cap and Trade (MECT) program, Chevron Phillips Chemical shut down their boilers and started purchasing steam from a nearby cogeneration facility. As documented in the RBLC, however, boilers were used for controlling PE and PP emissions prior to that time.

If technically and economically feasible, due to the high temperature and long residence times typical of boilers and process heaters, high destruction efficiencies (greater than 98%) can be achieved.²⁷

The use of flares, thermal oxidizers, catalytic oxidizers and/or boilers to reduce HRVOC emissions from polymer plants is built upon the assumption that the uncontrolled emissions can be effectively captured. The effective, efficient and safe capture of reactive monomer streams must be evaluated on a case-by-case basis.

3.4.5 Bekaert Burners

Another alternative to flaring is use of Bekaert CEB® burners²⁸. Bekaert burners use a meshed fiber surface that divides the main flame into tiny flames thereby resulting in more complete combustion of the HRVOC in the waste gas stream. Bekaert reports that HRVOC destruction efficiencies as high as 99.99% have been achieved at operating temperatures of 2,000-2,200°F with NO_x emissions less than 15 ppm. The capacity on the largest burner model Bekaert currently makes is approximately 2,500 scfm. As discussed in Section 4, with one exception, the annual average flare flowrates at the Harris County polymer production facilities surveyed is less than 2,500 scfm. However, to handle emergencies and other large releases, the flare design capacities are much greater than 2,500 scfm.



Figure 5. Bekaert Burners

Based on information provided by Bekaert, there are six of their systems currently in use in the Houston area. Four of these are at petrochemical plants. The largest system in use is used to control emissions (non-HRVOC) from barge loading and unloading operations. Since the burner uses fine fiber mesh, presence

²⁷ Ibid

²⁸ Information on Bekaert burners is derived from discussions with Mr. Timothy F. Egan, Bekaert Corporation, and from their website: <http://www.bekaert.com/flaring>

of particulate matter in the waste gas stream may clog the flame openings thereby impairing performance.

Figure 5 shows in-field installation of two Bekaert CEB® Model 4500 burners (Source: Bekaert website). Currently, these are Bekaert’s largest models.

3.4.6 Stripping

Stripping is used in SBR production to remove un-reacted monomer from the rubber crumb, with the overheads routed to a combustion device for destruction. Stripping is common in SBR production facilities; however, the intent of the stripping is primarily to remove the un-reacted styrene. The un-reacted 1,3-butadiene is removed through flash distillation and reduction in system pressure.

Review of the RBLC identified two facilities where stripping is used to control emissions from SBR production facilities. Table 8 summarizes the findings.

Table 8. Examples of Stripping Used to Control HRVOC Emissions	
Company:	Firestone Polymers LLC
Location:	Lake Charles, Louisiana
Permit Date:	07/30/2003
Process Description:	Styrene butadiene rubber production
Control Application:	Steam stripping of solvent from crumb rubber. Emissions stream from stripping operation is collected and routed to flare
Control Efficiency:	Unknown
Company:	Goodyear Tire and Rubber Company
Location:	Beaumont, Texas
Permit Date:	02/19/2004
Process Description:	Styrene butadiene rubber production
Control Application:	Air stripping. Application is unspecified.
Control Efficiency:	Not specified

While search of the RBLC did not identify any instances of either air or steam stripping being used to control emissions from PE or PP production facilities, as discussed in Section 4, nitrogen stripping is used to remove un-reacted monomer in PE and PP production facilities.

3.4.7 Adsorption / Concentration

Adsorption is the attachment of gaseous molecules to the surface of a solid. During adsorption, a gas molecule migrates from the gas stream to the surface of the solid where it is held by physical attraction. Adsorption in the form of a concentrator can be used to raise the concentration of an organic vapor to provide more economical treatment in downstream

combustion or condensation devices. Activated carbon is the most widely used adsorbent for VOCs. Other adsorbents include zeolites and certain synthetic polymers.²⁹

Factors that influence the performance of activated carbon in controlling gas phase VOC emissions include:³⁰

- *The type of compound to be removed.* In general, compounds with a high molecular weight and higher boiling point are better adsorbed.
- *Concentration.* The higher the concentration the better the adsorption.
- *Temperature.* The lower the temperature the greater the adsorption capacity.
- *Pressure.* The higher the pressure the greater the adsorption capacity.
- *Humidity.* The lower the humidity the greater the adsorption capacity.

As shown in Table 9, HRVOCs are low molecular weight compounds with low boiling points.³¹

Table 9. Physical Properties of HRVOCs		
Compound	Molecular Weight	Boiling Point (°C)
Ethylene	28	-104
Propylene	42	-48
1,3-Butadiene	54	-4
1-Butene	56	-5
2-Butene (cis & trans)	56	+3
Isobutylene	56	-7

Vents from extruders and downstream operations will typically have low HRVOC concentrations and pressures close to ambient. Collectively, this information indicates that activated carbon would, most likely, be a poor choice for either direct control of HRVOC emissions or for use in a concentrator. The limitations affecting adsorption using activated carbon would also be expected to affect adsorption using zeolites or polymer adsorbents.

Concentrator suppliers have stated that, for a concentrator to be effective, the boiling point of the material to be adsorbed should be higher than the inlet gas phase temperature, but lower

²⁹ *Choosing an Adsorption System for VOC: Carbon, Zeolite, or Polymers?* EPA Technical Bulletin, EPA 456/F-99-004, May 1999.

³⁰ EPA Air Pollution Cost Manual. 6th Edition, EPA/452/B-02-001, January 2002.

³¹ *Chemical Engineer's Handbook*, 5th Edition, edited by Robert H. Perry and Cecil H. Chilton, McGraw-Hill Book Company, 1973.

than the desorption temperature. For applications involving the HRVOCs listed in Table 9, the boiling points would be less than the desorption temperature; however, they would not be above the inlet temperature. This “rule of thumb” confirms that HRVOCs are not amenable to adsorption or concentration.

Review of the RBLC did not identify any application of adsorption for the control of HRVOC emissions from polymer plants in the last 10 years.

3.4.8 Biofiltration / Bioscrubbing

Biofiltration involves routing a vent gas stream through a biologically active media, similar to compost, where the pollutants of interest are adsorbed and/or absorbed and biologically degraded into water and carbon dioxide. A bioscrubber is similar in function; however, the control system involves a tower packed with synthetic media that supports a biological culture. Biofiltration and bioscrubbing have been successfully applied in a number of full-scale applications to control odors, VOC and emissions of air toxics from a wide range of sources. Application of biofiltration and bioscrubbing are typically limited to relatively low concentration vent streams – approximately 1,000 ppm or less – and the pollutants need to be water soluble.³² HRVOC compounds are generally slightly soluble to insoluble in water, making them poor candidates for control through biofiltration.

3.4.9 Refrigerated Condensers

A refrigerated condenser is a control device that is used to cool an emission stream containing organic vapors and to condense the organic vapors into a liquid that is then collected and either recycled or disposed of. Refrigerated condensers work best on emission streams containing high concentrations of VOC. To achieve any reduction, even on saturated streams, the condenser must achieve a temperature that is lower than the boiling point of the compound in question.

HRVOC emissions from extruders and downstream operations are poor candidates for control through use of refrigerated condensers because: 1) the boiling points are low (refer to Table 9) and 2) the concentration of HRVOC in the vents is expected to be low.

3.4.10 Non-Thermal Plasma

Low-temperature, non-thermal plasma (NTP) is a developing technology that may, in the future, be an option for controlling emissions of HRVOC.³³ The basic principle of NTP is the use of

³² EPA Survey of Control Technologies for Low Concentration Organic Vapor Gas Streams. EPA/456/R-95-003, May 1995.

³³ Pulsed Corona Plasma Pilot Plant for VOC Abatement in Industrial Streams as Mobile and Educational Laboratory. Tak, G., Gutsol, A. and Fridman, A., 2005. (<http://plasma.mem.drexel.edu/publications/documents/ISPC-ID670.pdf>)

electricity to create a plasma – an ionized gas containing free electrons.³⁴ These energetic electrons excite, dissociate and ionize molecules to produce chemically active radicals and ions. In the laboratory, NTP has been shown to have ability to destroy a number of different VOCs and polycyclic aromatic hydrocarbons (PAHs).³⁵ Pilot-scale experiments conducted at pulp mills and wood product plants have shown VOC destruction efficiencies greater than 98%.³⁶ In theory, NTP could be used to treat industrial waste gas streams containing HRVOC across a wide range of flow rates.³⁷ NTP, however, has not been demonstrated on a commercial scale nor has it been demonstrated to control emissions of HRVOC.

3.5 Flare Minimization

Flare minimization refers to the reduction in the number of instances of flaring, both during routine operations and during startup, shutdown and malfunction, and to the reduction in the quantity of material flared. The concept of flare minimization applies to both stream recycling/reuse and flare gas recovery.

3.5.1 Recycling/Reuse

As discussed in Section 2.2, a significant percentage of HRVOC emissions occur during maintenance, startup, and shutdown (MSS) activities and during emission events. Through certain capital investments (e.g. the addition of process loops and storage capacity) and changes in the way that the production units are managed during MSS activities, the amount of HRVOC released to the flare header can be significantly reduced. Following are two examples of recycling and reuse at Harris County facilities.

- One Harris County olefins producer implemented a flare minimization program that resulted in reduced flaring during the shutdown and startup of the unit. The shutdown and startup of the unit is a sequence of steps where each section of the process is shutdown or started before the next section. Past practice had been to vent to the flare during this sequence until the unit was gas-free during shutdown or until producing on-specification product when going through startup. The operator made modifications to the process that allowed for streams to be recycled within the unit that dramatically reduced the amount of material sent to the flare during shutdown and startup.

³⁴ Application of Non-Thermal Plasma for Air Pollution Control

(http://miedept.mie.uic.edu/lab/kennedy/Application_Plasma_4.htm)

³⁵ Pulsed Corona Plasma Pilot Plant for VOC Abatement in Industrial Streams as Mobile and Educational Laboratory. Tak, G., Gutsol, A. and Fridman, A., 2005. (<http://plasma.mem.drexel.edu/publications/documents/ISPC-ID670.pdf>)

³⁶ Pulsed Corona Plasma Technology for Treating VOC Emissions from Pulp Mills, July 28, 2004.

(<http://www.osti.gov/energycitations/servlets/purl/826442-clriuJ/826442.PDF>)

³⁷ Destruction of Highly Diluted Volatile Organic Compounds (VOCs) in Air by Dielectric Barrier Discharge and Mineral Bed Adsorption. Martin, L., Ognier, S., Gasthauer, E., Cavadias, S., Dresvin, S. and Amouroux, J. *Energy & Fuels*. Vol. 22, 576-582, 2008.

- As discussed in the HARC Project H-76 report, as of 2006, one Harris County olefins producer was planning on sending off-specification HRVOC to an off-site salt dome storage facility for later reprocessing. This would result in a reduction in HRVOC emissions from flaring by approximately 17 tons/year at a projected capital cost of approximately \$700,000.³⁸

3.5.2 Flare Gas Recovery

Flare Gas Recovery (FGR) refers to taking low pressure waste gases in the flare header, compressing the gases, and then reprocessing them or using them as a fuel gas in the plant. When the flow is less than or equal to the capacity of the FGR system, the flare gas will be recovered. During these periods of normal operations, emissions from the flare will approach zero. When the flare gas flow rate is greater than the capacity of the FGR system, the excess flare gas will flow through a liquid seal drum and to the flare tip for combustion. FGR systems are designed for recovering waste gases during normal operations. During non-routine operating conditions (e.g. MSS and emission events), excess waste gas will flow to the flare for combustion.

Potential benefits of FGR include:

- Waste gas may have substantial heating value and could be used as a fuel source in the plant, thereby reducing fuel purchase costs;
- Waste gas could be used as feedstock or product in certain applications; and
- Emissions from flaring would be reduced.

FGR is widely used in petroleum refineries. As part of multi-facility, “global” consent agreements with the USEPA, a number of major petroleum refining companies have committed to installing FGR at one or more of their refineries. The Harris County refineries that are part of global consent agreements with EPA are:

- ExxonMobil Baytown Refinery,
- Shell Deer Park Refinery, and
- Valero Houston Refinery.³⁹

³⁸ *How Chemical Manufacturing and Petroleum Refining Facilities in Harris County are Using Point Source Monitoring to Identify and Reduce HRVOC Emissions*, HARC Project H-76, ENVIRON International Corporation, prepared for the Houston Advanced Research Center, October 2006.

³⁹ *Petroleum Refinery Consent Decree Emission Reduction Assessment for Ozone and Regional Haze SIPs*, ENVIRON International Corporation, prepared for the Texas Commission on Environmental Quality, November 2007.

The ExxonMobil, Shell and Valero global consent agreements do not require the installation of FGR at these refineries. However, the ExxonMobil and Shell agreements specify compliance with the emission limits of New Source Performance Standard (NSPS) Subpart J (40 CFR 60.104(a)); specifically the provision that

“No owner or operator subject to the provisions of this subpart shall: (1) Burn in any fuel gas combustion device any fuel gas that contains hydrogen sulfide (H₂S) in excess of 230 mg/dscm (0.10 gr/dscf).”

Compliance may require the installation of FGR on some flares. Assuming the FGR system is sized to handle worst-case flows during normal operations, emissions from these flares during normal operations should be limited to pilot gas combustion, or very close to zero.⁴⁰

There are a number of potential limitations to use of FGR in olefins, derivatives (e.g. propylene oxide production) and polymer manufacturing facilities. These include:⁴¹

- Refineries have fuel gas headers that collect high heat content waste streams from around the refinery, compress it, and send it to boilers and/or process heaters for use as a fuel. Olefins, derivatives and polymer production facilities do not typically have this same infrastructure.
- The combustion characteristics of high concentration olefin or olefin derivative streams may not be conducive to use as a fuel. For example, propylene oxide burns explosively.
- Use of the olefin or olefin derivative as a fuel may result in undesirable environmental impacts. For example, ethylene burns very hot and results in the formation of excess NO_x.
- The olefins may polymerize in the flare header, leading to plugging with associated safety and performance implications.

As with all other emission control approaches, the technical and economic feasibility of flare gas recovery must be evaluated on a case-by-case basis.

⁴⁰ Ibid.

⁴¹ Developed during discussions with industry representatives during the survey portion of the project.

4 Facility Survey Findings

As discussed in the Introduction, ENVIRON prepared and sent questionnaires to certain Harris County industrial sites for the purpose of gathering information on projects that have been implemented to reduce HRVOC emissions at those sites, the costs of those projects, and on other HRVOC emission reduction projects that have been considered but not implemented. ENVIRON developed separate questionnaires for flare issues and polymer production issues. The questionnaire templates are included in Appendix A.

The TCEQ identified 16 sites in Harris County to receive one or both of the surveys. Of the 16 sites, 11 participated by responding to the surveys and/or meeting with ENVIRON personnel to discuss their responses. Participating sites included 4 olefin plants and 9 polymer plants. Two facilities, out of the 11 that participated in the study, are involved in the manufacture of both polymers and olefins. Additionally, one facility that did not provide a response to the survey suggested that information obtained as part of HARC Project H76 be included in this investigation. That facility contains both petroleum refining and olefins production operations.

Survey findings are presented and discussed within this section.

4.1 Polymer Plant Questionnaire Results

4.1.1 Process Types Surveyed

ENVIRON received survey responses from polymer plants that use the following processes:

- Polyethylene – low density, high pressure process
- Polyethylene – low density, low pressure process
- Polyethylene – high density, gas phase process
- Polyethylene – high density, liquid-phase slurry process
- Polyethylene – high density, liquid-phase solution process
- Polypropylene – liquid-phase slurry process
- Polypropylene – gas phase process

The number of process units in operation in the above-listed categories is presented in Figure 6. All polymer plants surveyed operate multiple process types and units at their sites.

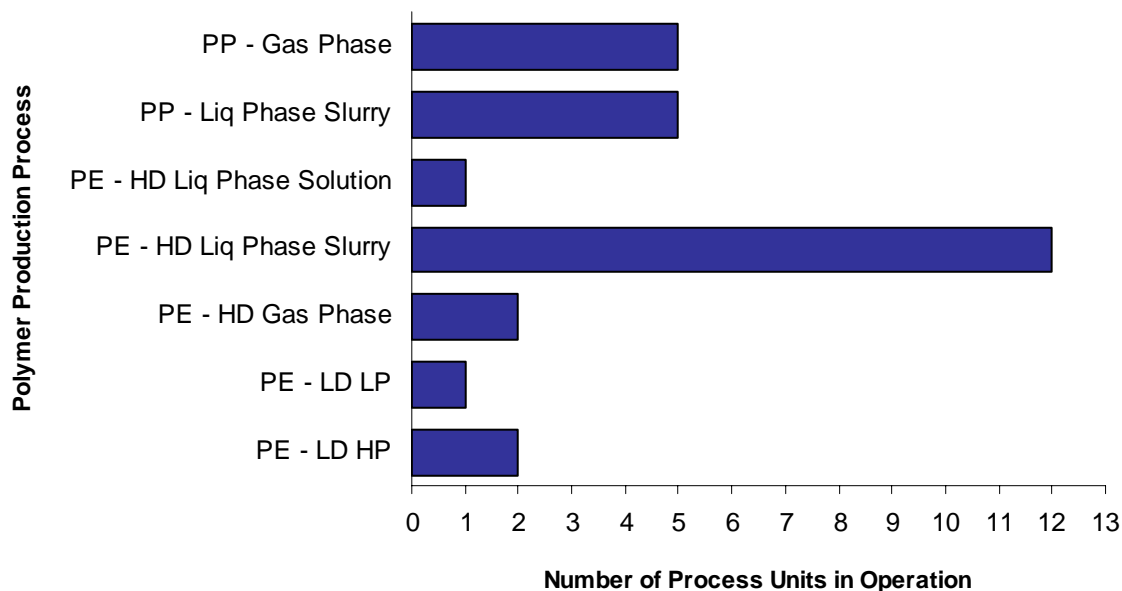

Figure 6. Type and Number of Operational Polymer Process Units

4.1.2 Process Vent Control Techniques

ENVIRON asked survey respondents whether process vents located upstream of the extruder were recycled back to the process or routed to a control device. Responses are summarized in Table 10. The number of process units utilizing each control technique is presented in the table. All polymer plants surveyed operate multiple process units.

Process Type	Recycled to Process	Flare	Boiler	Process Heater	Thermal Oxidizer	FGR	Catalytic Oxidizer
PE – low density, high pressure	2	1	1	0	1	0	1
PE – low density, low pressure process	1	1	0	0	0	0	1
PE – high density, gas phase process	1	2	0	0	1	0	1
PE – high density, liquid-phase slurry	11	12	8	0	0	0	0
PE – high density, liquid-phase solution	1	1	0	1	1	0	0

Process Type	Recycled to Process	Flare	Boiler	Process Heater	Thermal Oxidizer	FGR	Catalytic Oxidizer
PP – liquid-phase slurry	6	6	1	0	0	3	0
PP – gas phase	5	5	1	0	0	2	0
Total	27	28	11	1	3	5	3

4.1.3 Finishing Operations

ENVIRON asked survey respondents whether finishing vents (i.e., extruder and downstream to storage and loading) are routed to a control device. Nine facilities responded to this part of the survey.

- **No Control.** Of the nine facilities that responded to this part of the survey, five facilities have no control on the extruder, product storage or loading operations. Emissions from these facilities are from uncontrolled atmospheric vents.
- **Thermal Oxidation.** Two facilities use thermal oxidizers to control HRVOC emissions from the extruders and/or downstream operations. One facility routes the emissions from extruder vents to a thermal oxidizer. The other facility routes emissions from dryer vents and storage silos to a thermal oxidizer.
- **Catalytic Oxidation.** One facility routes intermediate storage emissions generated from the high-pressure LDPE manufacturing process to a catalytic oxidizer.
- **Flare.** One facility routes its dryer vents to a flare for control, but other finishing vents are uncontrolled.

4.1.4 HRVOC Emission Reduction Projects

ENVIRON asked survey respondents whether any projects had been implemented to reduce emissions in response to the HRVOC rules. Projects could include, but were not limited to, process changes, changes in operating procedures, vent stream controls and/or flare minimization. Excluded from the survey were costs associated with installation of HRVOC monitoring equipment and any emission reductions that may have resulted from more robust monitoring of emissions. A detailed analysis of the costs of control and HRVOC emission reductions associated with the installation of HRVOC monitoring equipment is included in *How Chemical Manufacturing and Petroleum Refining Facilities in Harris County Are Using Point Source Monitoring to Identify and Reduce HRVOC Emissions*.⁴²

⁴² *How Chemical Manufacturing and Petroleum Refining Facilities in Harris County are Using Point Source Monitoring to Identify and Reduce HRVOC Emissions*, HARC Project H76, ENVIRON International Corporation, prepared for

Table 11 summarizes the projects identified by survey respondents.

Table 11. Summary of HRVOC Emission Reduction Projects				
Project ID	Project Name	Process Type	Capital Cost (\$)	HRVOC Reduction (tpy)
P1	Vent Gas Recovery	Polyethylene – low density, high pressure process	650,000	40
P2	Ethylene Recovery Unit	Polypropylene – gas phase process	1,000,000	15
P3	De-inventory to propylene storage ¹	Polypropylene – liquid-phase slurry process	50,750	See note below
P4	Installation of Regenerative Thermal Oxidizer	Polyethylene – low density, high pressure process	11,500,000	143
P5	Changes to startup procedure ²	Polyethylene – liquid-phase process	0	0.5
P6	Replacement of Catalytic Oxidizer with Thermal Oxidizer with higher DRE	Polyethylene – liquid-phase solution process	364,000	0.5
P7	Re-routing of extruder vents from carbon beds to thermal oxidizer	Polyethylene – liquid phase process	127,000	1
P8	Installation of PSA system	Polypropylene – liquid-phase slurry and gas-phase processes	7,000,000	42
P9	PSA system operability improvements	Polypropylene – liquid-phase slurry and gas-phase processes	400,000	1
P10	Implementation of more efficient purge bin distributor design	Polypropylene – liquid-phase slurry and gas-phase processes	800,000	20

the Houston Advanced Research Center, October 2006.

Table 11. Summary of HRVOC Emission Reduction Projects

Project ID	Project Name	Process Type	Capital Cost (\$)	HRVOC Reduction (tpy)
P11	Routing of relief devices to flare ³	Polypropylene – gas-phase process	175,000	See note below
P12	Installation of HRVOC caps and plugs ³	Polypropylene – gas-phase process	75,000	See note below
P13	Implementation of leak detection probe ³	Polypropylene – gas-phase process	8,000	See note below
P14	Installation of HRVOC awareness monitors ³	Polypropylene – gas-phase process	15,000	See note below
P15	Installation of HRVOC sample points and caps and plugs ⁴	Polypropylene – liquid-phase slurry and gas-phase processes	93,500	See note below
P16	Installation of pump trap on compressor ⁴	Polypropylene – liquid-phase slurry and gas-phase processes	130,000	See note below
P17	Routing of pump off-gas flow to Flare Gas Recovery system ⁴	Polypropylene – liquid-phase slurry and gas-phase processes	47,100	See note below
P18	Installation of HRVOC monomer efficiency monitors ⁴	Polypropylene – liquid-phase slurry and gas-phase processes	26,000	See note below
P19	Implementation of leak detection probe ⁴	Polypropylene – liquid-phase slurry and gas-phase processes	6,000	See note below
P20	Implementation of atmospheric PSV monitoring ⁴	Polypropylene – liquid-phase slurry and gas-phase processes	53,000	See note below
P21	Enhancement of propylene storage sample system ⁴	Polypropylene – liquid-phase slurry and gas-phase processes	59,000	See note below

Table 11. Summary of HRVOC Emission Reduction Projects				
Project ID	Project Name	Process Type	Capital Cost (\$)	HRVOC Reduction (tpy)
P22	Flare Gas Recovery system upgrade ⁴	Polypropylene – liquid-phase slurry and gas-phase processes	321,000	See note below
P23	Flare Gas Recovery system upgrade ⁴	Polypropylene – liquid-phase slurry and gas-phase processes	20,000	See note below

¹ Estimated HRVOC reductions between 1 - 3 tpy depending on frequency and duration of shutdown. Facility did not provide detailed information regarding the frequency and duration of shutdown; therefore, annualized HRVOC reductions were not estimated.

² Startup performed once every two to three years. The estimated HRVOC reductions are annualized.

³ Facility provided total HRVOC emission reductions attributed to projects P11 – P14 of 27.14 tpy. However, HRVOC emission reductions attributed to each project were not available.

⁴ Facility provided total HRVOC emission reductions attributed to projects P15 – P23 of 21.67 tpy. However, HRVOC emission reductions attributed to each project were not available.

Additional details regarding the projects referenced in Table 11 are provided below.

- Project P1.** The facility collected emissions from 8 continuous hourly production silos. Each storage silo stores approximately one hour’s worth of production. HRVOC emissions collected from these intermediate storage silos are routed to a catalytic oxidizer for control. Previously, emissions from these production silos were uncontrolled. HRVOC emission reductions due to the implementation of this project are estimated to be approximately 40 tpy.
- Project P2.** The facility installed an ethylene recovery unit on an off-gas stream to recover up to 3,000,000 pounds of ethylene from the flare header system. Taking into account an assumed 99% destruction and removal efficiency (DRE), the recovery of 3,000,000 pounds of ethylene translates to post-flare HRVOC emission reductions of approximately 15 tpy.
- Project P3.** This project consisted of piping modifications which allowed the facility to recycle liquid slurry back to monomer storage instead of flaring during shutdown. Depending on the duration of shutdown, HRVOC emission reductions are estimated to be between 1 and 3 tons per hour (tph) during the event.
- Project P4.** The facility installed an RTO for MON/HRVOC compliance requirements. Post-extruder HRVOC emissions from the pellet dryer vent, compressor distance pieces and the pellet silo storage vents are routed to the thermal oxidizer. Previously, these emission sources were uncontrolled. HRVOC emission reductions due to the implementation of this project are estimated to be approximately 143 tpy.

- **Project P5.** The facility implemented procedural changes to pressure check the reactor before startup. Isobutane is used instead of ethylene as part of the reactor start-up procedure, thereby reducing the use of ethylene during this process. This operational procedure is repeated once every two to three years. Annualized HRVOC emission reductions are estimated to be approximately 0.5 tpy.
- **Project P6.** The facility replaced an existing catalytic oxidizer with a thermal oxidizer that achieves a higher DRE. HRVOC emission reductions due to this project are estimated to be approximately 0.5 tpy.
- **Project P7.** The facility rerouted the extruder vents from existing carbon adsorber beds to a thermal oxidizer. HRVOC emission reductions due to this rerouting are estimated to be approximately 1 tpy.
- **Project P8.** The facility installed a Pressure Swing Absorption (PSA) system to capture all continuous vent streams that were previously routed to the flare for control. These vent streams consist primarily of nitrogen (75%), with the remainder being propylene (25%). The PSA system recovers, condenses and recycles propylene back to the process in liquid form. Also, nitrogen is recycled back to the process. HRVOC emission reductions due to this project are estimated to be approximately 42 tpy.
- **Project P9.** The facility made improvements to the operability of its PSA system and routed additional small vents (e.g., analyzer vents, dry gas seals) to the PSA. HRVOC emission reductions due to this project are estimated to be approximately 1 tpy.
- **Project P10.** The facility implemented a more efficient distributor design on its purge bin. The redesigned distributor results in greater volatilization of the monomer from the polypropylene flake prior to the flake entering atmospheric storage vessels, thereby reducing atmospheric emissions. HRVOC emission reductions due to this project are estimated to be approximately 20 tpy.
- **Projects P11 through P14.** The facility implemented several projects related to reducing atmospheric emissions of HRVOC from atmospheric relief valves and fugitive components.⁴³ Projects included the following:
 - *Routing of atmospheric relief devices to flare.* Pressure relief devices on the polypropylene dryers, which were previously routed to the atmosphere, were tied in to the flare header.
 - *Installation of HRVOC caps and plugs.* All the caps and plugs in VOC service were replaced with plugs painted fluorescent yellow for easy identification and were tethered to a cable so that they could be found easily if not in place.
 - *Implementation of leak detection probe.*

⁴³ Unlike other polymer facilities surveyed, this facility implemented projects primarily related to fugitive emission reductions and monitoring.

- *HRVOC awareness monitors.* Project involved installation of a monitor in the control room to allow for continual monitoring of the monomer efficiency, HRVOC permit compliance and energy utilization at the unit.

Additionally, process improvements and improvements in operational reliability, mechanical integrity and monomer efficiency have contributed to HRVOC emission reductions at the facility. HRVOC emission reductions due to the capital projects and other improvements are estimated to be 27.14 tpy.

- **Projects P15 through P23.** The facility implemented several projects related to reducing atmospheric emissions of HRVOC from atmospheric relief valves and fugitive components and to upgrading the existing Flare Gas Recovery (FGR) system. Projects included the following:
 - *Installation of HRVOC sample points and caps and plugs.* Project involved the installation of HRVOC sampling points on various process vent streams. The project also involved purchasing miscellaneous piping caps and plugs for lines in hydrocarbon service. All the caps and plugs in VOC service were replaced with plugs painted fluorescent yellow for easy identification and were tethered to a cable so that they could be found easily if not in place.
 - *Installation of pump trap on compressor.* Project involved installing a skid mounted pump trap system on the sour oil/seal gas return line located in the propylene distillation section. This system allows for the separation of propylene entrained in the sour oil, allowing the propylene emissions to discharge to the flare header instead of the atmosphere.
 - *Routing of off-gas flow to FGR.* Project involved installation of pipe with control valve to allow off-gas from compressor pump trap to be separately fed to FGR. Project was needed to optimize monomer efficiency.
 - *Installation of HRVOC monomer efficiency monitors.* Project involved installation of monitors in control rooms to allow for continuous monitoring of HRVOC and monomer efficiency.
 - *Implementation of leak detection probe.*
 - *Implementation of atmospheric PSV monitoring.* Wireless pressure transmitters were installed on pressure relief valves, which are routed to the atmosphere, and tied into the DCS so that the time and duration of each pressure relief event could be monitored.
 - *Enhancement of propylene storage sample system.* Sampling system on the propylene storage bullets was tied to the flare header to prevent atmospheric releases while sampling.
 - *Two FGR upgrades.* One project improved the reliability of the FGR system from 95% to 99%. A second project improved the reliability of the FGR and improved the recovery of propylene and hexane.

Additionally, process improvements and improvements in operational reliability, mechanical integrity and monomer efficiency have contributed significantly to HRVOC emission reductions at the facility. HRVOC emission reductions due to the capital projects and other improvements are estimated to be 21.67 tpy.

ENVIRON also asked respondents about HRVOC emission reduction projects that had been considered, but not implemented. Details related to those projects are discussed below.

- **Storage Silo Control.** This project would have reduced monomer emissions from storage silos at a polyethylene manufacturing facility (low density, high pressure process). The project would have involved the installation of multiple transfer lines to different storage silos to route low heat value waste gas streams to a catalytic oxidizer. If implemented, the project would have required a capital investment of approximately \$5MM for a catalytic oxidizer to reduce HRVOC emissions by up to 40 tpy.
- **Propylene Nitrogen Recovery Unit (PNRU).** The implementation of the PNRU project would have reduced HRVOC emissions by recovering the monomer (propylene) and reusing it in the polypropylene production process. For safety reasons, nitrogen, which is inert, would be used to recover propylene. In a typical PNRU application, the vent stream from the resin degassing bin is compressed and then cooled to condense the propylene. The gas leaving the condenser, which contains a significant amount of propylene, is fed to a membrane unit. The membrane unit separates the stream into a propylene-enriched permeate stream and a purified nitrogen stream. The permeate stream is recycled to the inlet of the compressor and then to the condenser, where the propylene is recovered. The purified nitrogen stream is recycled to the degassing bin.⁴⁴

Two different polymer manufacturing facilities have considered installation of a PNRU. Implementation of the two PNRU projects would involve capital expenditures of greater than \$1 MM and \$12 MM, respectively.⁴⁵ Neither facility provided any information regarding estimated HRVOC emission reductions that would have been achieved by the implementation of PNRU.

- **Isobutane Nitrogen Recovery Unit (INRU).** The INRU is conceptually similar to PNRU except that it would be used to recover isobutane from the polyethylene production process. In addition to recovering isobutane, ethylene would potentially be recovered using INRU. Neither cost nor potential HRVOC emission reduction information was provided by the facility that considered this project.

⁴⁴ http://www.mtrinc.com/polypropylene_production.html

⁴⁵ The \$12 MM estimate is considered more refined; the greater than \$1 MM provided by one facility is considered a rough estimate of the minimum amount of capital investment required.

- **Off-gas Recycle.** The off-gas recycle project would recycle the reactor off-gas back to the polypropylene production process. To make the necessary modifications and process changes would require a capital investment in excess of \$1 MM.
- **Route Vents to Flare Header.** This project would involve routing reactor vents and atmospheric relief valves to a process flare header. While not yet implemented, the survey respondent indicated that the facility is proceeding with implementation in the near future. The flare header must be modified to handle the large potential flow during emergency shutdown. The facility plans to install a distributed control system (DCS) to program the shutdown sequence. The current estimated cost for this project is \$8 MM. No estimate of the reduction in HRVOC emissions to be realized was provided.

Routine emissions at this facility are routed to a thermal oxidizer. This project would only affect MSS and event emissions.

- **Ethylene Recovery Unit.** This project would involve routing intermediate flake tanks vents to an Ethylene Recovery Unit (ERU). Currently, these intermediate tanks are uncontrolled. Because the flake tanks are designed for atmospheric pressure, the facility would have to design a pressure control scheme, install piping and auxiliary equipment in addition to the ERU. The estimated cost for this project is \$10 MM. No estimate of the reduction in HRVOC emissions to be realized was provided.

4.1.5 Excess Monomer Removal

ENVIRON asked survey respondents whether excess monomer was removed from resins prior to finishing operations (i.e., extruder vents and vents downstream of the extruder). Nine facilities responded to this part of the survey. Responses are discussed below.

- **No Control.** Four of the nine facilities that responded to this part of the survey did not report any processes in place to recover raw materials prior to finishing operations.⁴⁶
- **Catalytic Oxidation.** One facility routes emissions from a tertiary degasser for LLDPE and HDPE to a catalytic oxidizer.
- **Hot Nitrogen Purge.** One facility purges the polyethylene and polypropylene fluff with hot nitrogen into a closed loop system which also includes the extruder feed tank. Residual hydrocarbons recovered are eventually sent to the flare. In another facility, excess monomer is recovered from the polymer slurry prior to the production of pellets. In the liquid-phase slurry process, hot nitrogen stripping is used to recover the monomer in downstream units. For the liquid-phase solution process, the excess monomer is stripped using nitrogen and a system of centrifuges and flash dryers.

⁴⁶ Although these four facilities did not report any processes in place to recover raw materials prior to finishing operations, these facilities may operate a closed loop system with nitrogen purge.

- Low Pressure Recovery.** One facility uses a low pressure recovery compressor to recover nitrogen, ethylene and isobutane from the facility’s intermediate polyethylene flake storage tanks. These intermediate tanks store polyethylene flake prior to extrusion. The recovery compressor routes the nitrogen, ethylene and isobutane to a flare. This stream is approximately 99% isobutane.
- Ethylene Recovery Unit.** The same facility employing low pressure recovery also utilizes an Ethylene Recovery Unit (“ERU”). The ERU is a three step, cryogenic process, by which ethylene is recovered from the resins prior to finishing operations. Recovered ethylene is recycled to the process, routed to a boiler as fuel or routed to a flare if the boiler is not operational. Note that both the low pressure recovery system and the ERU were installed by the facility prior to the advent of the HRVOC rules.
- Pressure Swing Absorption.** One facility utilizes a Pressure Swing Absorption (“PSA”) system to capture all continuous vent streams that were previously routed to the flare for control. These vent streams consist primarily of nitrogen (75%), with the remainder being propylene (25%). The PSA system recovers, condenses and recycles propylene back to the process in liquid form. Also, nitrogen is recycled back to the process.

4.1.6 Costs of Polymer Plant HRVOC Emission Reduction Projects

Table 12 summarizes the cost effectiveness of HRVOC reduction projects implemented by polymer processing facilities as listed in Table 11. As noted in the discussion following Table 11, the largest project in terms of total capital investment, P4, was implemented for MON/HRVOC compliance, not just for controlling HRVOC emissions.

Project ID	Capital Cost (\$)	Annualized Capital Cost¹ (\$)	Direct and Indirect Annual Cost (\$)	Total Annual Cost² (\$)	HRVOC Emission Reduction (tpy)	Cost Effectiveness³ (\$/tpy)
P1	650,000	130,000	5,000	135,000	40	3,375
P2	1,000,000	200,000	Not Provided	200,000	15	13,333
P3	50,750	10,150	Not Provided	10,150	See Note ⁴	N/A
P4	11,500,000	2,300,000	120,000	2,420,000	143	16,923
P5	0	0	0	0	0.5	N/A ⁵
P6	364,000	72,800	25,000	97,800	0.5	195,600
P7	127,000	25,400	5,000	30,400	1	30,400
P8	7,000,000	1,400,000	Not Provided	1,400,000	42	33,333
P9	400,000	80,000	Not Provided	80,000	1	80,000
P10	800,000	160,000	Not Provided	160,000	20	8,000

Project ID	Capital Cost (\$)	Annualized Capital Cost¹ (\$)	Direct and Indirect Annual Cost (\$)	Total Annual Cost² (\$)	HRVOC Emission Reduction (tpy)	Cost Effectiveness³ (\$/tpy)
P11 – P14	273,000	54,600	Not Provided	54,600	27.14	2,012
P15 – P23	755,600	151,120	Not Provided	151,120	21.67	6,974

¹ Based on five-year project life and a discount rate of 0%.

² Total Annual Cost = Annualized Capital Investment + Direct and Indirect Annual Cost

³ Cost Effectiveness = Total Annual Cost / Total HRVOC Emission Reduction

⁴ Estimated HRVOC reductions between 1 - 3 tpy depending on frequency and duration of shutdown. Facility did not provide detailed information regarding the frequency and duration of shutdown; therefore, annualized HRVOC reductions were not estimated.

⁵ Startup performed once every two to three years. The estimated HRVOC reductions are annualized. Total capital investment and annual costs are negligible, so cost of control is effectively zero but HRVOC emission reductions are low.

ENVIRON asked survey participants to provide estimates of total capital investment as well as direct and indirect annual costs. As noted in Table 12, annual cost information was not made available for all projects. Some facilities indicated they do not track annual costs for these projects separately from other annual costs.

As shown in Table 12, there is a wide range in cost effectiveness, ranging from \$2,012 to \$195,600 per ton per year of HRVOC controlled.

4.2 Flare Questionnaire Results

4.2.1 Flare Inventory

Figure 7 shows the number of flares in HRVOC service by industry sector. Figure 7 also shows the percentage of average flow to maximum design flow for the flares in service. As shown in Figure 7, under normal operating conditions, flares in HRVOC service operate at 0.6% - 7.1% of the maximum design flow. The percentage of design flow for each industry sector was determined by calculating the average value for the flares within a particular industry sector. For the facilities that responded to this survey, average flows across all sectors were approximately 4.4% of flare design capacity. The range was from less than 0.0001% to 38%. Most flares are designed to handle maximum flow rates expected during facility upsets. Therefore, instead of having a dedicated flare for HRVOC control, most facilities use one flare for both routine and emergency operations. All but three of the 31 flares at respondent facilities are designed to handle routine and emergency flows.

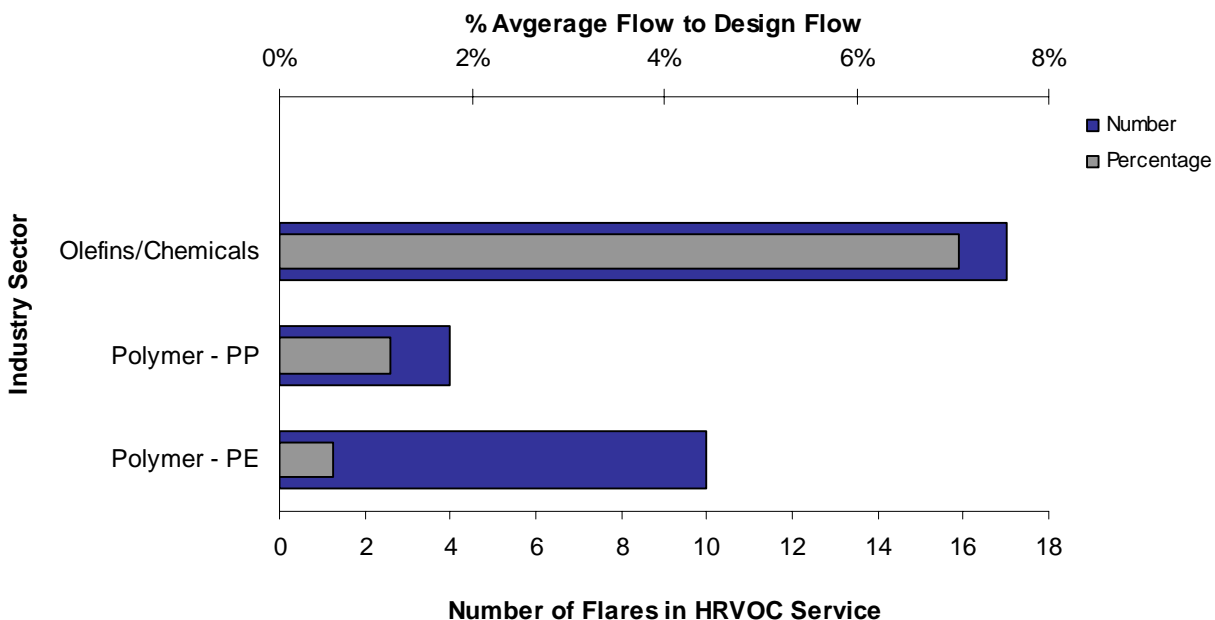

Figure 7. Percent Average Flow and Number of Flares in HRVOC Service

4.2.2 Flare Reduction and Minimization Projects

ENVIRON asked survey respondents whether any projects had been implemented to reduce or minimize flaring. Responses are summarized in Table 13.

Project ID	Project Name	Process Type	Capital Cost (\$)	HRVOC Reduction (tpy)
F1	Flare Gas Recovery	Polypropylene – gas phase process	608,400	12 – 14
F2	Flare Gas Recovery ¹	Polypropylene – liquid-phase slurry and gas phase processes	970,000	5 – 10
F3	Vent Recycle	Polyethylene – low density, high pressure process	50,000	10 – 12
F4	Modifications to Shutdown Procedure	Polyethylene – low density, high pressure process	N/A	N/A
F5	Modifications to Shutdown Procedure	Polyethylene - high density, gas phase process	N/A	2

Table 13. Summary of HRVOC Flare Reduction and Minimization Projects

Project ID	Project Name	Process Type	Capital Cost (\$)	HRVOC Reduction (tpy)
F6	Ethylene Recovery Unit	Polypropylene – gas phase process	1,000,000	15
F7	De-inventory to propylene storage ²	Polypropylene – liquid-phase slurry process	50,750	See note below
F8	Modifications to Startup and Shutdown Procedures	Polypropylene – liquid-phase and gas phase processes	N/A	N/A
F9	Chiller Replacement Project	Olefins	3,500,000	85
F10	Flareless Startup and Shutdown	Olefins	1,100,000	50 – 100
F11	Rerouting Degassing Vent	Olefins	106,250	6.75
F12	Modifications to Startup Procedure	Polyethylene – liquid phase process	0	0.5
F13	Addition of Calorimeters to Vent Gas Monitoring System	Polyethylene – liquid phase process	183,000	1
F14	Flare Gas Recovery	Refinery	17,900,000	9
F15	Flare Gas Recovery	Refinery	34,500,000	45
F16	Heavy Ends Stream Recovery	Olefins	220,000	50
F17	Olefins Flare Reduction	Olefins	550,000	9
F18	Off-spec monomer to off-site storage	Olefins	700,000	17

¹ Project is installed, but not yet operating.

² Estimated HRVOC reductions between 1 - 3 tpy depending on frequency and duration of shutdown.

Projects P2, P3 and P5 from Table 11 also appear as Projects F6, F7 and F12 in Table 13. These projects cannot be classified solely as polymer projects as their implementation also affected HRVOC emissions through flaring. Therefore, these projects are included in the discussion of both polymer plant and flare projects.

Additional details concerning the projects referenced in Table 13 are provided below.

- **Project F1.** The facility is using an existing compressor to remove the waste gas from the flare header using suction pressure. The waste gas is the reactor off-gas from the polypropylene (gas phase) process. This waste gas is sold to a neighboring facility for use as boiler fuel. HRVOC emission reductions are estimated to be between 12 and 14 tpy.
- **Project F2.** The facility installed a compressor to remove the waste gas from the flare header using suction pressure. The waste gas is the reactor off-gas from the polypropylene (liquid-phase slurry and gas phase) processes. However, the project is not operational yet. When operational, HRVOC emission reductions are estimated to be between 5 and 10 tpy.
- **Project F3.** The facility added a recycle stream from the purge gas vessel. These emissions are routed back to the process (polyethylene – low density, high pressure). Reductions in HRVOC emissions due to reduced flaring as a result of vent recycle are estimated to be 10 to 12 tpy.
- **Projects F4, F5, F8, and F12.** Several facilities have modified their startup/shutdown procedures to minimize flaring emissions. One such modification to shutdown procedures (Project F4) is to reduce the reactor pressure before flaring. Reactor off-gas is recompressed and sent to purification step to recover ethylene. In another project (Project F5), the facility changed the product transition procedure to route the initial purge from the flare to the site's ethylene unit fuel gas system. This reduced 19,000 lbs of ethylene per product transition or approximately 300,000 lbs/yr out of the flare. Assuming 99% flare destruction efficiency, the estimated HRVOC emission reductions are 2 tpy. In Project F12, modifications to startup procedures include pressure checking the reactor with isobutane instead of ethylene, resulting in annualized HRVOC emission reductions of approximately 0.5 tpy.
- **Project F6.** The facility installed an ethylene recovery unit on an off-gas stream to recover up to 3,000,000 pounds of ethylene from the flare header system. Taking into account an assumed 99% DRE, the recovery of 3,000,000 pounds of ethylene translates to post-flare HRVOC emission reductions of approximately 15 tpy.
- **Project F7.** This project consisted of piping modifications which allowed the facility to recycle liquid slurry back to monomer storage instead of flaring during shutdown. Depending on the duration of shutdown, HRVOC emission reductions are estimated to be between 1 and 3 tpy during the event.
- **Project F9.** The facility implemented this project to condense and recover C4 compounds (mostly 1,3-butadiene) from vent streams in the olefins plant. This project has reduced the load on vent recovery compressors, thereby minimizing or eliminating the bypass of HRVOCs to the flare. HRVOC emission reductions due to minimized flaring are estimated to be approximately 85 tpy.
- **Project F10.** The facility was able to achieve 75 – 80% reduction in HRVOC emissions due to flaring with the implementation of “flareless” startup/shutdown procedures. These reductions in flaring translate into HRVOC emission reductions of 50 to 100 tpy.

- **Project F11.** The facility rerouted the propylene compressor degassing pot vent back to the process. The vent was previously routed to the flare. Reductions in HRVOC emissions due to flaring as a result of vent recycle into the process are estimated to be approximately 6.75 tpy.
- **Project F13.** The facility added calorimeters to the already existing vent gas monitoring system. The addition of calorimeters allows operations personnel to identify any spike in the heat value of the waste gas stream in a timely manner. This is also helpful in identifying a source that may be inadvertently venting to the flare. This project has resulted in a reduction of 0.5 to 1 tpy of HRVOC emissions due to flaring.
- **Project F14 and F15.** The refinery implemented two flare gas recovery projects. The flare gas recovery systems have resulted in HRVOC reductions of approximately 9 and 45 tpy, respectively. Additional details regarding these projects are not available; however, it is known that the projects were not implemented for purpose of achieving HRVOC emission reductions.
- **Project F16 and F17.** The olefins plant implemented two flare minimization projects. The flare minimization projects have resulted in HRVOC reductions of approximately 50 and 9 tpy, respectively. Additional details regarding these projects are not available.
- **Project F18.** The facility sends off-specification monomer from the process to off-site salt dome storage well during start-up and shutdown, resulting in HRVOC reductions of approximately 17 tpy.

4.2.3 Flare Gas Recovery

Six facilities responded to this part of the survey. Two facilities, both polypropylene manufacturers, have installed FGR systems for flare minimization. Four facilities have not implemented FGR. Responses from two facilities discussing why they have not implemented FGR are as follows:

- At one facility, the flare controls only relief devices and emergency emissions. The flare header normally handles low flow rates. Therefore, a compressor installed for FGR would only run for short periods of time.
- At an olefins facility, tie-ins do not exist in the existing plant layout; therefore, any modification would require a major turnaround. Because it is an olefins plant, any oxygen ingress into the process resulting from operation of the FGR system could result in a dangerous situation. Another challenge for the olefins plant is the storage of off-spec material for future reuse. Currently, the plant is not equipped to store off-spec material or reuse it.

4.2.4 Costs of HRVOC Flare Reduction and Minimization Projects

Table 14 summarizes the cost effectiveness of HRVOC flare reduction and minimization projects implemented by polymer plants, olefins plants and refineries listed in Table 13.

Table 14. Cost Effectiveness of HRVOC Flare Reduction and Minimization Projects

Project ID	Capital Cost (\$)	Annualized Capital Cost ¹ (\$)	Direct and Indirect Annual Cost (\$)	Total Annual Cost ² (\$)	HRVOC Emission Reduction (tpy)	Cost Effectiveness ³ (\$/tpy)
<i>Polymer Plants:</i>						
F1	608,400	121,680	N/A	121,680	13	9,360
F2	970,000	194,000	N/A	194,000	7.5	25,867
F3	50,000	10,000	N/A	10,000	11	909
F4	N/A	N/A	N/A	N/A	N/A	N/A
F5	N/A	N/A	N/A	N/A	2	N/A
F6	1,000,000	200,000	N/A	200,000	15	13,333
F7	50,750	10,150	N/A	10,150	See Note ⁵	N/A
F8	N/A	N/A	N/A	N/A	N/A	N/A
F12	0	0	0	0	0.5	N/A
F13	183,000	36,600	15,000	51,600	1	51,600
<i>Olefins Plants:</i>						
F9	3,500,000	700,000	50,000	750,000	85	8,824
F10	1,100,000	220,000	N/A	220,000	75	2,933
F11	106,250	21,250	N/A	21,250	6.75	3,148
F16	220,000	44,000	N/A	44,000	50	880
F17	550,000	110,000	N/A	110,000	9	12,222
F18	700,000	140,000	N/A	140,000	17	8,235
<i>Refineries:</i>						
F14	17,900,000	3,580,000	N/A	3,580,000	9	397,778
F15	34,500,000	6,900,000	N/A	6,900,000	45	153,333
<i>Total:</i>						
w/ Refinery	61,438,400	12,287,680	65,000	12,352,680	346.75	35,624
w/o Refinery	9,038,400	1,807,680	65,000	1,872,680	292.75	6,397
¹ Based on five-year project life and a discount rate of 0% ² Total Annual Cost = Annualized Capital Investment + Direct and Indirect Annual Cost ³ If the facility provided a range of HRVOC emission reductions, the median is used. ⁴ Cost Effectiveness = Total Annual Cost / Total HRVOC Emission Reduction ⁵ Estimated HRVOC reduction between 1 - 3 tph depending on frequency and duration of shutdown.						

As shown in Table 14, there is a wide range in cost effectiveness, ranging from \$880 to nearly \$400,000 per ton of HRVOC controlled. As mentioned during discussion of the projects, the two refinery HRVOC abatement projects were not implemented for the purpose of reducing emissions of HRVOC. Excluding these two projects, cost effectiveness ranges from \$880 to \$51,600 per ton of HRVOC controlled.

4.3 Analysis

4.3.1 Types of Emission Reduction Projects

Survey participants provided information on 38 HRVOC emission reduction projects. A summary of these projects by industry sector and type is presented in Table 15. The types of projects are as follows:

Process Change:Change in how the product is made. For example, changing from a gas phase process to a liquid phase slurry process.

Change in Operating Procedures:Change in operating procedures such as enhanced maintenance or use of more robust process simulation to reduce emissions during startup and shutdown.

Vent Gas Control: Installation of controls on vent streams where none existed previously or upgrading to control systems with higher control efficiencies, such as routing vent streams to a thermal oxidizer instead of a flare.

Flare Minimization:Recovery of material for reuse instead of sending it to the flare header and/or recovering material in the flare header for beneficial reuse.

Industry Sector	Number of Plants Surveyed ¹	Type of HRVOC Emission Reduction Project			
		Process Change	Change in Operating Procedure	Vent Gas Control	Flare Minimization
Polymers	9	0	16	7	8
Olefins	4	0	1	0	4
Refining	1	0	0	0	2
Total	14	0	17	7	14

¹Two of the survey respondents manufacture both polymers and olefins at the site. One site contains both refining and olefins manufacturing operations.

As shown, no facility implemented a change in process for the purpose of reducing emissions of HRVOC.

4.3.2 Cost Effectiveness of Emission Reduction Projects

Table 16 presents a plant-by-plant summary of projects that have been undertaken to reduce emissions of HRVOC. As previously noted, the refinery projects were not undertaken for the sole purpose of reducing emissions of HRVOC. In many cases, the annual direct and indirect costs (e.g. natural gas to fuel a thermal oxidizer) have not been provided by survey respondents. In those cases, the actual annual costs and the cost of controlling HRVOC emissions will be greater than what is reported herein.

Site ¹	Number of Projects	Total Annual Cost ² (\$)	HRVOC Emission Reduction (tpy)	Cost Effectiveness ³ (\$/tpy)
Polymer 1	4	145,000	53	2,736
Polymer 2	1	200,000	15	13,333
Polymer 3	4	325,830	20.5	15,894
Polymer 4	1	2,420,000	143	16,923
Polymer 5	4	179,800	3	59,933
Polymer 7	3	1,640,000	63	26,032
Polymer 8	4	54,600	27.14	2,012
Polymer 9	9	151,120	21.67	6,974
<i>Polymer Plant Subtotal</i>	<i>30</i>	<i>5,116,350</i>	<i>346.31</i>	<i>14,774</i>
Olefins 1	1	140,000	17	8,235
Olefins 2	1	21,250	6.75	3,148
Olefins 3	2	970,000	160	6,036
Olefins 4	2	154,000	59	2,610
<i>Olefins Plant Subtotal</i>	<i>6</i>	<i>1,285,250</i>	<i>242.75</i>	<i>5,295</i>
Refinery 1	2	10,480,000	54	194,074
<i>Refinery Subtotal</i>	<i>2</i>	<i>10,480,000</i>	<i>54</i>	<i>194,074</i>
Total (w/ Refinery 1)	38	16,881,600	643.06	26,252
Total (w/o Refinery 1)	36	6,401,600	589.06	10,867

¹ Polymer Plant 6 did not implement any projects in response to the HRVOC rules.

² Total Annual Cost = Annualized Capital Investment + Direct and Indirect Annual Costs. Annualized Capital Investment assumes a 5-year project life and a discount rate of 0%. As indicated in Chapter 4, in many cases direct and indirect annual costs are not provided.

³ Cost Effectiveness = Total Annual Cost / Total HRVOC Emission Reduction

Figure 8 graphically presents plant-by-plant annual costs for HRVOC emission reduction projects and the resulting reduction in annual emissions. As shown, there is wide variation in:

- The number of HRVOC emission reduction projects undertaken at polymer plants (1-9),
- The amount of money spent on HRVOC emission reduction projects (annual costs of \$54,600 to \$2,420,000), and
- The reduction in HRVOC emissions achieved (3 tpy to 143 tpy)

Since the projects were not undertaken for purposes of reducing HRVOC emissions, Refinery 1 is not included in Figure 8. Also, because Polymer 6 did not implement any projects in response to the HRVOC rules, Polymer 6 is not included in Figure 8.

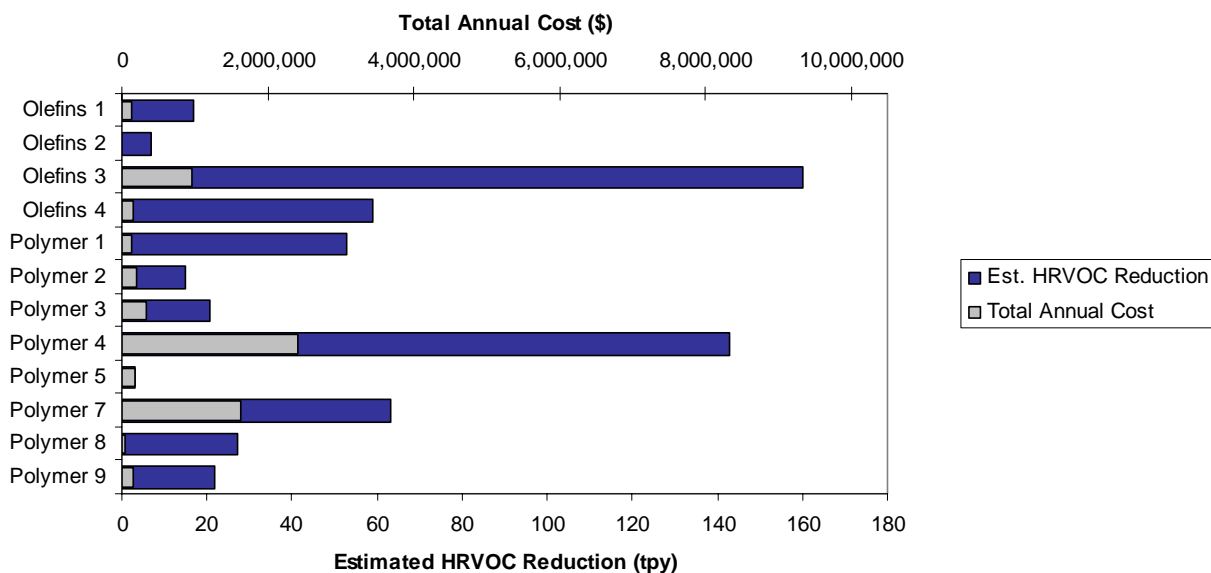

Figure 8. Cost and Emission Reduction Summary by Plant

Figure 9 presents a scatter plot of individual HRVOC emission control projects showing the reduction in HRVOC emissions as a function of annual cost. Excluded are projects where HRVOC emission reductions are not known (Projects P3, P11 - P14, P15 – P23, F4, F7, and F8). Since the projects were not undertaken for the purpose of reducing HRVOC emissions, Projects F14 and 15 are also excluded.

As shown, of the 20 projects included in Figure 9, the annual cost of 17 of the projects is less than \$250,000. Of the 20 projects, 14 resulted in HRVOC emission reductions of no more than 20 tpy.

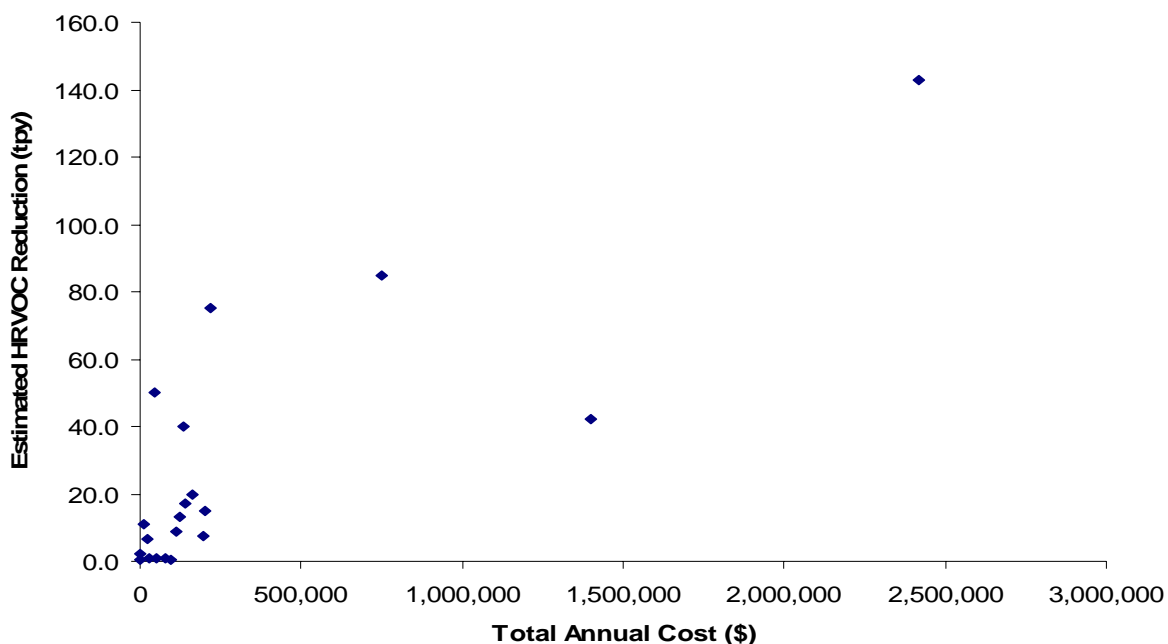

Figure 9. HRVOC Emission Reductions as a Function of Cost for Individual Projects

4.3.3 Projects Not Undertaken

As discussed in Section 4.1.4, there are a number of HRVOC emission reduction projects that were not undertaken by polymer plants. Based on discussions with industry personnel, the varied reasons include:

- They didn't need additional reductions in HRVOC emissions. This was because 1) emissions were already less than their HECT allowance allocation; and/or 2) the company manages their HRVOC emissions as a portfolio across a number of sites that may include polymer plants, olefins and chemical manufacturing sites and/or petroleum refineries and the portfolio as a whole may be sufficient.
- The cost of additional reductions in HRVOC emissions exceeded internal financial thresholds.

None of the companies surveyed have undertaken projects for the purpose of selling excess allowances. Reasons include:

- With little or no market activity to-date, there are not good pricing signals as to what HECT allowance vintages may be worth in the future. Therefore, there is insufficient information available to make sound investment decisions.
- Since MSS and event emissions (up to 1,200 pounds per hour) count toward the HECT annual cap, companies are unwilling to sell allowance stream ownership.

5 Conclusions & Recommendations

Conclusions and recommendations that ENVIRON is able to make from the information collected, compiled and analyzed as part of this project are as follows:

1. This study was designed to focus on HRVOC emission reduction projects implemented by polymer plants, and on determining whether additional cost effective control technologies were available to further reduce HRVOC emissions from polymer plants. A total of 30 projects were identified at nine plant sites with cost effectiveness ranging from \$2,012 to \$59,933 per ton of HRVOC controlled. Without additional information, it cannot be determined if polymer plants undertook more or fewer projects or if the cost effectiveness of those projects was higher or lower than those projects undertaken by other types of facilities. Determining whether additional controls to further reduce HRVOC emissions at polymer plants would be cost effective is most properly done on a case-by-case basis. No control technologies were identified that could be universally applied to achieve further reductions in HRVOC emissions from polymer plants in a cost-effective manner.

ENVIRON recommends that the TCEQ build upon this investigation by including other HECT-affected facilities.

2. Use of flares is by far the most common method for controlling emissions of HRVOC. Most of the flares used to control routine emissions of HRVOC are designed to handle the very large flow rates that may occur during MSS and emission events – “emergency flares.” For the facilities that responded to this survey, average flows were approximately 4.4% of flare design capacity. However, the range was from less than 0.0001% to 38%.

ENVIRON recommends that the TCEQ investigate: 1) the amount of HRVOC that is currently controlled by emergency flares and, 2) HRVOC destruction efficiency as a function of flare throughput (actual flow rate vs. design flow rate).

3. While not the focus of this investigation, it was determined during the conduct of this study that polymer production units employing different processes (e.g. gas-phase vs. liquid-phase slurry) may have very different emission profiles even though they are manufacturing a similar product (e.g. polyethylene). Although there are a number of different types of reactors that make polyethylene, there are differences in the polyethylene physical properties among the various technologies. The difference in physical properties determines the end use of the polyethylene. It was also determined that making changes to the type of process used to manufacture a product may require an investment on the order of replacing the entire production unit. This constitutes a significant barrier to change, given that some technologies are proprietary and/or licensed. No facility surveyed undertook a process change to reduce HRVOC emissions.

ENVIRON recommends further investigation into potential differences in emission profiles for the different types of polymer production processes. This information may be of value to the TCEQ should they consider revising the method for allocating HECT allowances.

6 Project Team Contact Information

TCEQ Project Representative: Teresa S. Hurley, P.E.
+1 512.239.5316
thurley@tceq.state.tx.us

ENVIRON Principal in Charge: Dr. Gregory Yarwood
+1 415.899.0704
gyarwood@environcorp.com

ENVIRON Principal Investigator and Project Manager: Steven H. Ramsey, P.E., BCEE
+1 713.470.6657
sramsey@environcorp.com

ENVIRON Co-Investigators: Christopher J. Colville, P.E.
+1 713.470.2647
ccolville@environcorp.com

Dr. Shagun Bhat
+1 713.470.2648
sbhat@environcorp.com

Appendix A: Questionnaire Templates

Polymer Plant Questionnaire
Cost Analysis of HRVOC Controls on Polymer Plants and Flares
TCEQ Work Order No. 582-07-84005-FY08-12

1. What type of process is used? Please select all that apply.

Polyethylene - low density, high pressure process

Polyethylene - low density, low pressure process

Polyethylene - high density, gas phase process

Polyethylene - high density, liquid-phase slurry process

Polyethylene - high density, liquid-phase solution process

Polypropylene - liquid-phase slurry process

Polypropylene - gas phase process

Other

2. Have any projects been implemented to reduce emissions in response to HRVOC rules? Projects could include process changes, pollution prevention techniques as well as add-on control technology.

Yes

No

If yes, please provide the following for each project: description, capital and annual cost, and estimated HRVOC reduction.

Project 1

Description:

Capital Cost (\$):

Annual Cost (\$):

Estimated HRVOC Reduction (tpy):

Project 2

Description:

Capital Cost (\$):

Annual Cost (\$):

Estimated HRVOC Reduction (tpy):

3. Have any HRVOC emission reduction projects been considered, but not implemented?

Yes

No

If yes, please select from among the following potential reasons.

High Cost (please describe what constitutes high cost)

Technical Infeasibility (please describe what constitutes technical infeasibility)

Other (please describe)

4. Are there emission reduction methods that would be technically feasible for new plants but not for existing plants?

Yes

No

If yes, how do they vary by type of production process?

Questionnaire Instructions

1. Please add responses to the yellow highlighted fields only.

2. For those questions requesting a "yes" or "no" response, please enter an "a" in the yellow highlighted field next to the appropriate response.

3. Please feel free to add additional projects for question 2, as necessary.

Polymer Plant Questionnaire
Cost Analysis of HRVOC Controls on Polymer Plants and Flares
TCEQ Work Order No. 582-07-84005-FY08-12

What is unique to your facility that would make emission reductions more difficult or more expensive?

Estimated costs and potential emission reduction?

Method 1

Description:

Capital Cost (\$):

Annual Cost (\$):

Estimated HRVOC Reduction (tpy):

Method 2

Description:

Capital Cost (\$):

Annual Cost (\$):

Estimated HRVOC Reduction (tpy):

5. Are process vents (i.e., upstream of extruder) recycled back to the process or routed to a control device (e.g., flare, thermal oxidizer, boiler, process heater)? Please select all that apply.

Recycled to Process

Flare

Boiler

Process Heater

Thermal Oxidizer

Other Add-on Control Device (please describe)

6. Are there VOC control devices on any finishing vents (i.e., extruder and downstream to storage and loading)?

Yes

No

If yes, please describe.

7. Is excess monomer removed from the pellets prior to the finishing operations (e.g., steam stripping)?

Yes

No

If yes, please describe how.

Flare Questionnaire
Cost Analysis of HRVOC Controls on Polymer Plants and Flares
TCEQ Work Order No. 582-07-84005-FY08-12

1. How many flares are in HRVOC service?

Please provide the average or typical flow and design capacity for each flare in HRVOC service.

EPN	Average Flow (MMscf/hr)	Design Flow (MMscf/hr)
<input type="text"/>	<input type="text"/>	<input type="text"/>

2. Have any projects been implemented to reduce or minimize flaring?

Yes
 No

If yes, please provide the following for each project: description, capital and annual cost, and estimated HRVOC reduction.

Project 1
Description:
Capital Cost (\$):
Annual Cost (\$):
Estimated HRVOC Reduction (tpy):

Project 2
Description:
Capital Cost (\$):
Annual Cost (\$):
Estimated HRVOC Reduction (tpy):

3. Have any flare minimization/reduction projects been considered, but not implemented?

Yes
 No

If yes, please select from among the following potential reasons.

High Cost (please describe what constitutes high cost)

Technical Infeasibility (please describe what constitutes technical infeasibility)

Other (please describe)

4. What factors affect the cost and feasibility of flare minimization projects at your facility?

Questionnaire Instructions

1. Please add responses to the yellow highlighted fields only.

2. For those questions requesting a "yes" or "no" response, please enter an "a" in the yellow highlighted field next to the appropriate response.

3. Please feel free to add additional projects for questions 2 and 5, as necessary.

Flare Questionnaire
Cost Analysis of HRVOC Controls on Polymer Plants and Flares
TCEQ Work Order No. 582-07-84005-FY08-12

5. Have any projects been conducted to route additional uncontrolled streams to flare?

Yes
 No

If yes, please provide the following for each project: description, capital and annual cost, and estimated HRVOC reduction.

Project 1

Description:

Capital Cost (\$):

Annual Cost (\$):

Estimated HRVOC Reduction (tpy):

Project 2

Description:

Capital Cost (\$):

Annual Cost (\$):

Estimated HRVOC Reduction (tpy):

6. Is a flare gas recovery (FGR) system installed at the plant?

Yes
 No

If no, has any consideration been given to FGR as a potential flare minimization project?

Yes
 No

7. Are any HRVOC process vents routed to a thermal oxidizer for control?

Yes
 No