

Texas Commission on Environmental Quality

Title V Existing

4119

Site Information (Regulated Entity)

What is the name of the permit area to be authorized?	COMANCHE PLANT
Does the site have a physical address?	No
Because there is no physical address, describe how to locate this site:	1939 FM 1450
City	PECOS
State	TX
ZIP	76722
County	REEVES
Latitude (N) (##.#####)	31.313333
Longitude (W) (-###.#####)	103.209444
Primary SIC Code	1321
Secondary SIC Code	
Primary NAICS Code	211112
Secondary NAICS Code	
Regulated Entity Site Information	
What is the Regulated Entity's Number (RN)?	RN109161745
What is the name of the Regulated Entity (RE)?	COMANCHE PLANT
Does the RE site have a physical address?	No
Because there is no physical address, describe how to locate this site:	FROM PECOS, TX TAKE US-285 S/S CEDAR ST AND GO 3.2 MILES. TURN LEFT ONTO FM 1450 E AND DRIVE 15.1 MILES AND THEN TURN RIGHT AND GO 0.8 MILE TOWARDS THE FACILITY LOCATION.
City	PECOS
State	TX
ZIP	79772
County	REEVES
Latitude (N) (##.#####)	31.313222
Longitude (W) (-###.#####)	-103.226028
Facility NAICS Code	
What is the primary business of this entity?	NATURAL GAS PLANT

Customer (Applicant) Information

How is this applicant associated with this site?	Owner Operator
What is the applicant's Customer Number (CN)?	CN605077106
Type of Customer	Corporation
Full legal name of the applicant:	
Legal Name	Brazos Midstream Operating, LLC
Texas SOS Filing Number	802169329
Federal Tax ID	
State Franchise Tax ID	32056577227
State Sales Tax ID	
Local Tax ID	
DUNS Number	86549467
Number of Employees	0-20
Independently Owned and Operated?	Yes

Responsible Official Contact

Person TCEQ should contact for questions about this application:	
Organization Name	BRAZOS MIDSTREAM OPERATING III LLC
Prefix	MR
First	JUSTIN
Middle	
Last	BETO
Suffix	
Credentials	
Title	VP OPERATIONS
Enter new address or copy one from list:	
Mailing Address	
Address Type	Domestic
Mailing Address (include Suite or Bldg. here, if applicable)	777 MAIN ST STE 3700
Routing (such as Mail Code, Dept., or Attn:)	
City	FORT WORTH
State	TX
ZIP	76102

Phone (###-###-####)	8173326800
Extension	
Alternate Phone (###-###-####)	
Fax (###-###-####)	
E-mail	beto@brazosmidstream.com

Technical Contact

Person TCEQ should contact for questions about this application:

Select existing TC contact or enter a new contact.

Organization Name	GARY MANN(BRAZOS MIDSTREA...)
Prefix	BRAZOS MIDSTREAM OPERATING LLC
First	MR
Middle	GARY
Last	MANN
Suffix	
Credentials	
Title	ENVIRONMENTAL MANAGER
Enter new address or copy one from list:	
Mailing Address	
Address Type	Domestic
Mailing Address (include Suite or Bldg. here, if applicable)	777 MAIN ST STE 3700
Routing (such as Mail Code, Dept., or Attn:)	
City	FORT WORTH
State	TX
ZIP	76102
Phone (###-###-####)	6824294839
Extension	
Alternate Phone (###-###-####)	
Fax (###-###-####)	
E-mail	mann@brazosmidstream.com

Title V General Information - Existing

1) Permit Type:	SOP
2) Permit Latitude Coordinate:	31 Deg 18 Min 48 Sec

3) Permit Longitude Coordinate:	103 Deg 12 Min 34 Sec
4) Is this submittal a new application or an update to an existing application?	Update
4.1. Select the permit/project number for which this update should be applied.	4119-37272
5) Does this application include Acid Rain Program or Cross-State Air Pollution Rule requirements?	No

Title V Attachments Existing

Attach OP-1 (Site Information Summary)

Attach OP-2 (Application for Permit Revision/Renewal)

Attach OP-ACPS (Application Compliance Plan and Schedule)

Attach OP-REQ1 (Application Area-Wide Applicability Determinations and General Information)

[File Properties]

File Name

</ePermitsExternal/faces/file?fileId=332530>>OP-REQ1.pdf

Hash

A86FF897411CBEE83578127BDD78DFFAFD1C2B76B7E2D5EA2AB585F856BA3BA0

MIME-Type

application/pdf

Attach OP-REQ2 (Negative Applicable Requirement Determinations)

Attach OP-REQ3 (Applicable Requirements Summary)

Attach OP-PBRSUP (Permits by Rule Supplemental Table)

Attach OP-SUMR (Individual Unit Summary for Revisions)

Attach OP-MON (Monitoring Requirements)

Attach OP-UA (Unit Attribute) Forms

If applicable, attach OP-AR1 (Acid Rain Permit Application)

Attach OP-CRO2 (Change of Responsible Official Information)

Attach OP-DEL (Delegation of Responsible Official)

Attach Void Request Form

Attach any other necessary information needed to complete the permit.

[File Properties]

File Name	OP-CRO1 512026.pdf
Hash	AD118C4C45B611E06759220321C5FF57C931A02CD2BDC37F19EB6C561428502B
MIME-Type	application/pdf

An additional space to attach any other necessary information needed to complete the permit.

[File Properties]

File Name	Email Log 512026.pdf
Hash	50D77B574916761730340F578E09676074B070E6927BD81A0E3C54FB2F729AA2
MIME-Type	application/pdf

Certification

I certify that I am the Responsible Official for this application and that, based on information and belief formed after reasonable inquiry, the statements and information on this form are true, accurate, and complete.

1. I am Justin D Beto, the owner of the STEERS account ER101679.
2. I have the authority to sign this data on behalf of the applicant named above.
3. I have personally examined the foregoing and am familiar with its content and the content of any attachments, and based upon my personal knowledge and/or inquiry of any individual responsible for information contained herein, that this information is true, accurate, and complete.
4. I further certify that I have not violated any term in my TCEQ STEERS participation agreement and that I have no reason to believe that the confidentiality or use of my password has been compromised at any time.
5. I understand that use of my password constitutes an electronic signature legally equivalent to my written signature.
6. I also understand that the attestations of fact contained herein pertain to the implementation, oversight and enforcement of a state and/or federal environmental program and must be true and complete to the best of my knowledge.
7. I am aware that criminal penalties may be imposed for statements or omissions that I know or have reason to believe are untrue or misleading.
8. I am knowingly and intentionally signing Title V Existing 4119.
9. My signature indicates that I am in agreement with the information on this form, and authorize its submittal to the TCEQ.

OWNER OPERATOR Signature: Justin D Beto OWNER OPERATOR

Account Number:

ER101679

Signature IP Address: 66.64.15.126
Signature Date: 2026-05-06
Signature Hash: AD43A1D9F4F07253C8AA43B9E5C41C0A5A6ACCD76D790174B2D601F6A78957BD
Form Hash Code at time of Signature: 0478EA2C3AB7863DF3A3B179F9306DE7DEFEAADC54ABAE7B7506AFE944C7C215

Submission

Reference Number: The application reference number is 921523
Submitted by: The application was submitted by ER101679/Justin D Beto
Submitted Timestamp: The application was submitted on 2026-05-06 at 10:45:44 CDT
Submitted From: The application was submitted from IP address 66.64.15.126
Confirmation Number: The confirmation number is 767280
Steers Version: The STEERS version is 6.94
Permit Number: The permit number is 4119

Additional Information

Application Creator: This account was created by Arthi R Reddy

From: [Arthi Reddy](#)
To: [Emily Knodell](#)
Cc: [Justin Bales](#); [Cliff Soltz](#); [Gordon Moore](#); [Gary Mann](#)
Subject: RE: Working Draft Permit - FDP 04119/Project 37272, Brazos Midstream Operating, LLC/Comanche Plant
Date: Wednesday, May 6, 2026 5:10:22 PM
Attachments: [image001.png](#)
[image002.png](#)
[image003.png](#)
[image004.png](#)
[image005.png](#)
[image007.png](#)
[image008.png](#)
[image009.png](#)
[image010.png](#)
[image011.png](#)
[image014.png](#)
[image013.png](#)
[image014.png](#)
[image015.png](#)
[image017.png](#)
[image018.png](#)
[image019.png](#)
[image020.png](#)
[image021.png](#)
[image022.png](#)
[image023.png](#)
[image024.png](#)
[image025.png](#)
[image026.png](#)
[image027.png](#)
[image028.png](#)
[image029.png](#)
[image030.png](#)
[image031.png](#)
[image032.png](#)
[image033.png](#)
[image034.png](#)
[image035.png](#)
[Comanche FDP-1119-Project_37272--562025.pdf](#)

Hi Emily,

Please see a COR of the electronic submission for the additional information requested in the email below. Please let me know if you need anything else or have any questions.

Thanks
Arthi

Texas Commission on Environmental Quality
Application Area-Wide Applicability Determinations and General Information
Form OP-REQ1
Federal Operating Permit Program

Date:	05/01/2026
Permit No.:	4119
RN No.:	RN109161745

For SOP applications, answer ALL questions unless otherwise directed.

◆ *For GOP applications, answer ONLY these questions unless otherwise directed.*

Form OP-REQ1: Page 2	
I. Title 30 TAC Chapter 111 - Control of Air Pollution from Visible Emissions and Particulate Matter (continued)	
B. Materials Handling, Construction, Roads, Streets, Alleys, and Parking Lots	
1. Items a - d determines applicability of any of these requirements based on geographical location.	
◆ a. The application area is located within the City of El Paso.	<input type="checkbox"/> YES <input checked="" type="checkbox"/> NO
◆ b. The application area is located within the Fort Bliss Military Reservation, except areas specified in 30 TAC § 111.141.	<input type="checkbox"/> YES <input checked="" type="checkbox"/> NO
◆ c. The application area is located in the portion of Harris County inside the loop formed by Beltway 8.	<input type="checkbox"/> YES <input checked="" type="checkbox"/> NO
◆ d. The application area is located in the area of Nueces County outlined in Group II state implementation plan (SIP) for inhalable particulate matter adopted by the TCEQ on May 13, 1988.	<input type="checkbox"/> YES <input checked="" type="checkbox"/> NO
<i>If there is any "YES" response to Questions I.B.1.a - d, answers Questions I.B.2.a - d. If all responses to Questions I.B.1.a-d are "NO," go to Section I.C.</i>	
2. Items a - d determine the specific applicability of these requirements.	
◆ a. The application area is subject to 30 TAC § 111.143.	<input type="checkbox"/> YES <input type="checkbox"/> NO
◆ b. The application area is subject to 30 TAC § 111.145.	<input type="checkbox"/> YES <input type="checkbox"/> NO
◆ c. The application area is subject to 30 TAC § 111.147.	<input type="checkbox"/> YES <input type="checkbox"/> NO
◆ d. The application area is subject to 30 TAC § 111.149.	<input type="checkbox"/> YES <input type="checkbox"/> NO
C. Emissions Limits on Nonagricultural Processes	
◆ 1. The application area includes a nonagricultural process subject to 30 TAC § 111.151.	<input checked="" type="checkbox"/> YES <input type="checkbox"/> NO
2. The application area includes a vent from a nonagricultural process that is subject to additional monitoring requirements. <i>If the response to Question I.C.2 is "NO," go to Question I.C.4.</i>	<input type="checkbox"/> YES <input checked="" type="checkbox"/> NO
3. All vents from nonagricultural process in the application area are subject to additional monitoring requirements.	<input type="checkbox"/> YES <input type="checkbox"/> NO

Texas Commission on Environmental Quality
Application Area-Wide Applicability Determinations and General Information
Form OP-REQ1
Federal Operating Permit Program

Date:	05/01/2026
Permit No.:	4119
RN No.:	RN109161745

For SOP applications, answer ALL questions unless otherwise directed.

◆ *For GOP applications, answer ONLY these questions unless otherwise directed.*

Form OP-REQ1: Page 87			
XII. NSR Authorizations (Attach additional sheets if necessary for sections E-J)			
E. PSD Permits and PSD Major Pollutants			
PSD Permit No.:	Issuance Date:	Pollutant(s):	
PSD Permit No.:	Issuance Date:	Pollutant(s):	
PSD Permit No.:	Issuance Date:	Pollutant(s):	
PSD Permit No.:	Issuance Date:	Pollutant(s):	
<i>If PSD Permits are held for the application area, please complete the Major NSR Summary Table located under the Technical Forms heading at: www.tceq.texas.gov/permitting/air/titlev/site/site_experts.html.</i>			
F. Nonattainment (NA) Permits and NA Major Pollutants			
NA Permit No.:	Issuance Date:	Pollutant(s):	
NA Permit No.:	Issuance Date:	Pollutant(s):	
NA Permit No.:	Issuance Date:	Pollutant(s):	
NA Permit No.:	Issuance Date:	Pollutant(s):	
<i>If NA Permits are held for the application area, please complete the Major NSR Summary Table located under the Technical Forms heading at: www.tceq.texas.gov/permitting/air/titlev/site/site_experts.html.</i>			
G. NSR Authorizations with FCAA § 112(g) Requirements			
NSR Permit No.:	Issuance Date:	NSR Permit No.:	Issuance Date:
NSR Permit No.:	Issuance Date:	NSR Permit No.:	Issuance Date:
NSR Permit No.:	Issuance Date:	NSR Permit No.:	Issuance Date:
NSR Permit No.:	Issuance Date:	NSR Permit No.:	Issuance Date:
◆ H. Title 30 TAC Chapter 116 Permits, Special Permits, Standard Permits, Other Authorizations (Other Than Permits By Rule, PSD Permits, NA Permits) for the Application Area			
Authorization No.: 140834	Issuance Date: 06/25/2025	Authorization No.:	Issuance Date:
Authorization No.:	Issuance Date:	Authorization No.:	Issuance Date:
Authorization No.:	Issuance Date:	Authorization No.:	Issuance Date:
Authorization No.:	Issuance Date:	Authorization No.:	Issuance Date:

Form OP-CRO1
Certification by Responsible Official
Federal Operating Permit Program

All initial permit application, revision, renewal, and reopening submittals requiring certification must be addressed using this form. Updates to site operating permit (SOP) and temporary operating permit (TOP) applications, other than public notice verification materials, must be certified prior to authorization of public notice or start of public announcement. Updates to general operating permit (GOP) applications must be certified prior to receiving an authorization to operate under a GOP.

I. Identifying Information		
RN: RN109161745	CN: CN605077106	Account No.: RFA032E
Permit No.: 4119	Project No.: 37272	
Area Name: Comanche Plant	Company Name: Brazos Midstream Operating LLC	
II. Certification Type <i>(Please mark the appropriate box)</i>		
<input type="checkbox"/> Responsible Official	<input checked="" type="checkbox"/> Duly Authorized Representative	
III. Submittal Type <i>(Please mark the appropriate box) (Only one response can be accepted per form)</i>		
<input type="checkbox"/> SOP/TOP Initial Permit Application	<input checked="" type="checkbox"/> Update to Permit Application	
<input type="checkbox"/> GOP Initial Permit Application	<input type="checkbox"/> Permit Revision, Renewal, or Reopening	
<input type="checkbox"/> Other: _____		
IV. Certification of Truth		
<p>This certification does not extend to information which is designated by the TCEQ as information for reference only.</p> <p>I, <u>Justin Beto</u> _____ certify that I am the DAR _____ <i>(Certifier Name printed or typed)</i> <i>(RO or DAR)</i></p> <p>and that, based on information and belief formed after reasonable inquiry, the statements and information dated during the time period or on the specific date(s) below, are true, accurate, and complete:</p> <p><i>Note: Enter Either a Time Period OR Specific Date(s) for each certification. This section must be completed. The certification is not valid without documentation date(s).</i></p> <p>Time Period: From <u>10/28/2024</u> _____ to <u>4/30/2026</u> _____ <i>Start Date</i> <i>End Date</i></p> <p>Specific Dates: _____ <i>Date 1</i> <i>Date 2</i> <i>Date 3</i> <i>Date 4</i> <i>Date 5</i> <i>Date 6</i></p>		
Signature: <u>Submitted via STEERS</u> _____ Signature Date: <u>5/1/2026</u> _____		
Title: <u>VP of Operations</u> _____		

From: Arthi Reddy
 To: Emily Knodell
 Cc: Gordon Moore; Gary Mann; Justin Bate
 RE: Working Draft Permit - FOP 04119/Project 37272, Brazos Midstream Operating, LLC/Comanche Plant
 Date: Friday, May 1, 2026 11:16:35 AM
 Attachments:
 image001.png
 image002.png
 image003.png
 image004.png
 image005.png
 image006.png
 image007.png
 image008.png
 image009.png
 image010.png
 image011.png
 image012.png
 image013.png
 image014.png
 image015.png
 image016.png
 image017.png
 image018.png
 image019.png
 image020.png
 image021.png
 image022.png
 image023.png
 image024.png
 image025.png
 image026.png
 image027.png
 image028.png
 image029.png
 image030.png
 image031.png
 image032.png
 image033.png
 image034.png
 image035.png
 Title_V WOP-Project_37272-04119_514026.pdf

Hi Emily,

Please see below my responses in red. I will follow-up with the submittal of all the revised pages via STEERS. I have also attached a copy of the same for your review. Please let me know if anything is missing or you need additional information.

Thank
 Arthi

From: Emily Knodell <Emily.Knodell@tceq.texas.gov>
 Sent: Thursday, April 30, 2026 2:47 PM
 To: Arthi Reddy <Arthi.Reddy@c-ka.com>
 Cc: Gordon Moore <gordon.moore@c-ka.com>; Gary Mann <mann@brazosmidstream.com>
 Subject: RE: Working Draft Permit - FOP 04119/Project 37272, Brazos Midstream Operating, LLC/Comanche Plant

Hello all,

During technical review, the following items were found. Please resolve by 05/06/2026. Please note that as we get ready for management review and prepare for public notice, our deadlines will become more time sensitive. This will help ensure that any remaining items are resolved promptly and we are able to successfully mail your project out to public notice.

- Form OP-REQ1 (Page 87):** For NSR 140834, there is a more recent issuance date listed in IDA, renewal issued 06/25/2025. Would you like to incorporate this date into the renewal? If so, please send an updated Form OP-REQ1, Page 87 which lists the newer date for NSR 140834. **Please see the revised page in the attached PDF.**
- Permit Consultant Info:** Arthi, please provide the information below so I can add your information to my project files.
Permit Consultant:
 <Name> Arthi Reddy
 <Title> Environmental Scientist
 <Company> CK Associates LLC
 <Address> 2001 E 70th Street Suite # 503 Shreveport LA 71105
 Phone: <Phone> 318-507-3035
 Email: <Email> Arthi.reddy@c-ka.com
- Form OP-CRO1:** At this time, I would like to ask for the form OP-CRO1 certifying the changes made to the application. Please fill out the Time Period from **10/28/2024 to 04/30/2026**. Please send me an electronic copy and the original, signed hardcopy. Alternatively, in lieu of the OP-CRO1, you can submit this email thread and attachments as an update to the application through STEERS. Any application updates that are submitted by the RODAR through STEERS are certified and do not require the submittal of an original signature OP-CRO1. STEERS does not accept the Outlook ".msg" file type, but it does take PDFs.
We will submit the OP-CRO1 form via STEERS as per your request. Attached the draft form.
- Form OP-REQ1 (Pages 2 & 3):** In the application OP-REQ1 (Page 2), I.C.1 is answered "No" regarding emission limits on nonagricultural processes. On the following page, I.D.1 is also answered "No". All permits should have one of these terms (either OP-REQ1 I.C.1 = Yes or I.D.1 = Yes) which will give you either 30 TAC Chapter 111.151 (Nonagricultural Processes term) or 30 TAC Chapter 111.171 (Agricultural Processes term). Please revisit these questions and revise accordingly. Your current permit has the nonagricultural processes term (see screenshot below), so I suspect OP-REQ1 (Page 2) Question I.C.1 should be "Yes".
Revised Page 2 - I.C.1 to Yes and included the updated Page in the attached PDF.

Texas Commission on Environmental Quality
 Application Area-Wide Applicability Determinations and General Information
 Form OP-REQ1
 Federal Operating Permit Program

Date:	09/03/2024
Permit No.:	4119
RN No.:	RN109161745

For SOP applications, answer ALL questions unless otherwise directed.
 For GOP applications, answer ONLY these questions unless otherwise directed.

Form OP-REQ1: Page 2

I. Title 30 TAC Chapter 111 - Control of Air Pollution from Visible Emissions and Particulate Matter (continued)

R. Materials Handling, Construction, Roads, Streets, Alleys, and Parking Lots

1. Items a - d determine applicability of any of these requirements based on geographical location.

a. The application area is located within the City of El Paso. YES NO

b. The application area is located within the Fort Bliss Military Reservation, except areas specified in 30 TAC § 111.141. YES NO

c. The application area is located in the portion of Harris County inside the loop formed by Beltway 8. YES NO

d. The application area is located in the area of Neacox County outlined in Group II state implementation plan (SIP) for inhalable particulate matter adopted by the TCEQ on May 13, 1988. YES NO

If there is any "YES" response to Questions I.B.1.a - d, answers Questions I.B.2.a - d. If all responses to Questions I.B.1.a-d are "NO," go to Section I.C.

2. Items a - d determine the specific applicability of these requirements.

a. The application area is subject to 30 TAC § 111.143. YES NO

b. The application area is subject to 30 TAC § 111.145. YES NO

c. The application area is subject to 30 TAC § 111.147. YES NO

d. The application area is subject to 30 TAC § 111.149. YES NO

C. Emissions Limits on Nonagricultural Processes

1. The application area includes a nonagricultural process subject to 30 TAC § 111.151. YES NO

2. The application area includes a vent from a nonagricultural process that is subject to additional monitoring requirements. YES NO
 If the response to Question I.C.2 is "NO," go to Question I.C.4.

3. All vents from nonagricultural process in the application area are subject to additional monitoring requirements. YES NO

Texas Commission on Environmental Quality
 Application Area-Wide Applicability Determinations and General Information
 Form OP-REQ1
 Federal Operating Permit Program

Date:	09/03/2024
Permit No.:	4119
RN No.:	RN109161745

For SOP applications, answer ALL questions unless otherwise directed.
 For GOP applications, answer ONLY these questions unless otherwise directed.

Form OP-REQ1: Page 3

I. Title 30 TAC Chapter 111 - Control of Air Pollution from Visible Emissions and Particulate Matter (continued)

C. Emissions Limits on Nonagricultural Processes (continued)

4. The application area includes oil or gas fuel-fired steam generators subject to 30 TAC §§ 111.155(a) and 111.155(c). YES NO

5. The application area includes oil or gas fuel-fired steam generators that are subject to additional monitoring requirements. YES NO
 If the response to Question I.C.5 is "NO," go to Question I.C.7.

6. All oil or gas fuel-fired steam generators in the application area are subject to additional monitoring requirements. YES NO

7. The application area includes solid fossil fuel-fired steam generators subject to 30 TAC §§ 111.155(a) and 111.155(b). YES NO

8. The application area includes solid fossil fuel-fired steam generators that are subject to additional monitoring requirements. YES NO
 If the response to Question I.C.8 is "NO," go to Section I.D.

9. All solid fossil fuel-fired steam generators in the application area are subject to additional monitoring requirements. YES NO

D. Emissions Limits on Agricultural Processes

1. The application area includes agricultural processes subject to 30 TAC § 111.171. YES NO

E. Outdoor Burning

1. Outdoor burning is conducted in the application area. YES NO
 If the response to Question I.E.1 is "NO," go to Section II.

2. Fire training is conducted in the application area and subject to the exception provided in 30 TAC § 111.205. YES NO

3. Fires for recreation, ceremony, cooking, and warmth are used in the application area and subject to the exception provided in 30 TAC § 111.207. YES NO

4. Disposal fires are used in the application area and subject to the exception provided in 30 TAC § 111.209. YES NO

Print this voucher for your records. If you are sending the TCEQ hardcopy documents related to this payment, include a copy of this voucher.

Transaction Information

Voucher Number: 828937
Trace Number: 582EA000732177
Date: 04/29/2026 03:24 PM
Payment Method: CC - Authorization 0000642333
Voucher Amount: \$450.00
Fee Type: TIER II - NON-MANUFACTURING
Fee AR Number: 0648304Q
ePay Actor: GORDON MOORE
Actor Email: gordon.moore@c-ka.com
IP: 50.252.162.41

[Delinquent Fee Payment](#)

[Brazos Midstream Operating, LLC](#)
[Comanche Plant](#)
[Pecos, Reeves County](#)
[Permit Number: 04119](#)
[CN605077106 / RN109161745](#)

[Account Number: 0648304Q](#)
[Fee Type :T2NM](#)
[Facility/Permit: 4119](#)
[Fee Amount: \\$450](#)

Payment Contact Information

Name: GORDON ROCKWELL MOORE
Company: CK ASSOCIATES
Address: 8951 UNITED PLAZA BLVD 300, BATON ROUGE, LA 70809
Phone: 225-755-1000

Billing Information

Billing Name: BRAZOS MIDSTREAM OPERATING LLC
Billing Address: 777 MAIN ST STE 3700, FORT WORTH, TX 76102 5376

Close

From: [Gordon Moore](#)
To: [Emily Knodell](#)
Cc: [Justin Beto \(beto@brazosmidstream.com\)](#); [Arthi Reddy](#)
Subject: FW: FW: Notice of Delinquent Fee and/or Penalty for Brazos Midstream Operating, LLC
Date: Wednesday, April 29, 2026 3:57:57 PM
Attachments: [TCEO ePay Brazos Comanche Acct 06483040 T2NM Permit 4119.pdf](#)

Emily,

I managed to typo you email address. Please see the email below regarding payment made on the delinquent fee.

Gordon Moore
CK

From: Gordon Moore
Sent: Wednesday, April 29, 2026 3:41 PM
To: emily.knodell@tceq.texas.gov
Cc: Justin Beto (beto@brazosmidstream.com) <beto@brazosmidstream.com>; Arthi Reddy <Arthi.Reddy@c-ka.com>
Subject: FW: Notice of Delinquent Fee and/or Penalty for Brazos Midstream Operating, LLC

Emily,

Please see the attached ePay receipt for the delinquent Tier II fee for the Brazos Comanche Plant. Thank you for clarifying the Account Number with Arthi.

Please reply all to confirm receipt.

Thanks,

Gordon R. Moore, P.E.
Area Manager/Sr. Engineer



2001 E 70th St., Suite 503
Shreveport, Louisiana 71105
318-797-8636 Office
318-507-3037 Direct
318-218-7651 Cell
www.c-ka.com

requirements. If an opacity test is performed and the source is determined to be in compliance, the RO may certify that the source is in compliance with the applicable opacity requirement. However, if an opacity test is performed and the source is determined to be out of compliance, the permit holder shall list this occurrence as a deviation on the next deviation report as required under 30 TAC § 122.145(2). The opacity test must be performed by a certified opacity reader.

- C. Certification of opacity readers determining opacities under Method 9 (as outlined in 40 CFR Part 60, Appendix A) to comply with opacity monitoring requirements shall be accomplished by completing the Visible Emissions Evaluators Course, or approved agency equivalent, no more than 180 days before the opacity reading.
- D. Emission limits on **nonagricultural processes**, except for the steam generators specified in 30 TAC § 111.153, shall comply with the following requirements:
 - (i) Emissions of PM from any source may not exceed the allowable rates as required in 30 TAC § 111.151(a) (relating to Allowable Emissions Limits)
 - (ii) Sources with an effective stack height (h_e) less than the standard effective stack height (H_s), must reduce the allowable emission level by multiplying it by $(h_e/H_s)^2$ as required in 30 TAC § 111.151(b)
 - (iii) Effective stack height shall be calculated by the equation specified in 30 TAC § 111.151(c)
- 4. The permit holder shall comply with the following requirements for units subject to any subpart of 40 CFR Part 60, unless otherwise stated in the applicable subpart:
 - A. Title 40 CFR § 60.7 (relating to Notification and Recordkeeping)
 - B. Title 40 CFR § 60.8 (relating to Performance Tests)
 - C. Title 40 CFR § 60.11 (relating to Compliance with Standards and Maintenance Requirements)
 - D. Title 40 CFR § 60.12 (relating to Circumvention)

Let me know if you have any questions!

Best Regards,

Emily L. Knodell
 Permit Reviewer
 TCEQ – APD – OP Section (Title V)
 (512) 239-3107

 How are we doing? Fill out our online customer satisfaction survey at www.tceq.texas.gov/customersurvey

From: Arthi Reddy <Arthi.Reddy@tceq.texas.gov>
Sent: Friday, April 17, 2026 5:44 PM
To: Emily Knodell <Emily.Knodell@tceq.texas.gov>
Cc: Gordon Moore <gordon.moore@tceq.texas.gov>; Gary Mann <manni@brazosmidstream.com>
Subject: RE: Working Draft Permit – FOP 04119/Project 37272, Brazos Midstream Operating, LLC/Comanche Plant

Hi Emily:

I reviewed the requirements and I am OK with the recordkeeping and reporting requirements standards for the pneumatic controllers. Everything else with the WDP looks good as well.

Thanks
 Arthi

From: Emily Knodell <Emily.Knodell@tceq.texas.gov>
Sent: Friday, April 10, 2026 3:39 PM
To: Arthi Reddy <Arthi.Reddy@tceq.texas.gov>
Cc: Gordon Moore <gordon.moore@tceq.texas.gov>; Gary Mann <manni@brazosmidstream.com>
Subject: RE: Working Draft Permit – FOP 04119/Project 37272, Brazos Midstream Operating, LLC/Comanche Plant

Good afternoon Arthi,

Thank you for sending the updated UA12. Please find attached WDP "Version 4" for your review as well as a response to your comment below. Please approve the WDP by **04/17/2026**.

Since this is a follow-up review to the previously submitted and reviewed WDP, only comments concerning changes since the last WDP may be considered by TCEQ. Any comments outside the scope of the most recent changes should be submitted as a separate project.

Based on the updated draft permit, it appears that the requirements you requested have now been included (Main Standard § 60.5400a(a)) for equipment leaks. The § 60.5390a(b)(1) main standard and associated requirements for the pneumatic controllers were included because you gave me Table 19c for Pneumatic Controller affected facilities. On Table 19c of the updated OP-UA12, codes 15+ and PCNGPP were provided for Unit ID FUG-1. Based on these responses, the site includes a pneumatic controller with a bleed rate of zero that has been constructed/modified/reconstructed after September 18th, 2015. The rule requires natural gas processing plants to have a bleed rate of zero for pneumatic controllers which is the standard (see screenshot of flowchart below). We believe these requirements should stay in the permit; you are an affected source under the definition regardless since you have continuous-bleed natural-gas-driven controllers. Keeping this would ensure recordkeeping, enforceability, and monitoring; just because you are in compliance does not mean the rule no longer applies. You could submit documentation demonstrating compliance with the zero-bleed standard if you still want the row removed, and this would have to go through review and approval by our team's technical specialist.

1 **Table 19c: Title 40 Code of Federal Regulations Part 60 (40 CFR Part 60)**
 2 **Subpart OOOOa: Standards of Performance for Crude Oil and Natural Gas Facilities for which Construction, Modification or Reconstruction Commenced**
 3 **After September 18, 2015**

Unit ID No.	SOP/GOP Index No.	Construction/Modification Date	Pneumatic Controller
5 FUG-1	60000a	15+	PCNGPP
6			
7			
8			
9			
10			
11			
12			
13			
14			

15 [Go to the Table of Contents](#)

Form OP-REQ2 - Negative Applicable/Superseded Requirement Determinations

Unit AI	Revision No.	Unit ID No.	Potentially Applicable Regulatory Name	Negative Applicability/Superseded Requirement Citation	Negative Applicability/Superseded Requirement Reason
		FUG-1	40 CFR Part 60, Subpart OOOO	§60.5365	The facility was constructed after the applicability date in this subpart.

[Go to the Table of Contents](#)

Form OP-SUM - Individual Unit Summary

Table 1

Unit AI	Revision No.	Unit ID No.	Group ID No.	Unit Name/Description	CAM	PCA AI	Preconstruction Authorization (PCA) Category	Authorization/Registration Number	Permit By Rule (PBR) Number	PBR Effective Date
		FUG-1		Fugitive Emissions			Standard Permit	140834		
		GRP-COMP	GRP-COMP	Compressor Engines			Standard Permit	140834		
		GRP-ELECOMPRES	GRP-ELECOMPRES	Electric Compressors			Standard Permit	140834		

[Go to the Table of Contents](#)

Table 1a: Title 40 Code of Federal Regulations Part 60 (40 CFR Part 60)

Subpart KKK: Standards of Performance for Equipment Leaks of VOC from Onshore Natural Gas Processing Plants

Unit ID No.	SOP/GOP Index No.	Facility Type	Construction/Modification Date	Facility Covered by 40 CFR Part 60, Subparts VV or GGG	Compressors	Reciprocating Compressor in Wet Gas Service	AMEL	AMEL ID No.	Complying with §60.482-3
FUG-1	60KKK-FUG1	GROUP	11+						

[Go to the Table of Contents](#)

Table 19b: Title 40 Code of Federal Regulations Part 60 (40 CFR Part 60)**Subpart OOOOa: Standards of Performance for Crude Oil and Natural Gas Facilities for which Construction, Modification or Reconstruction Commenced After September 18, 2015**

Unit ID No.	SOP/GOP Index No.	Construction/Modification Date	Reciprocating Compressor	AMEL	Bypass Device
GRP-COMP	600000a	15+	RC26K-	NO	
GRP-ELECOMPRES	600000a	15+	RC26K-	NO	

[Go to the Table of Contents](#)

Table 19d: Title 40 Code of Federal Regulations Part 60 (40 CFR Part 60)

Subpart OOOOa: Standards of Performance for Crude Oil and Natural Gas Facilities for which Construction, Modification or Reconstruction Commenced After September 18, 2015

Unit ID No.	SOP/GOP Index No.	Construction/Modification Date	Pneumatic Pump	Control Option	Control Device ID No.	Bypass Device
FUG-1	600000a	15+	PPNGPP			

[Go to the Table of Contents](#)



Table 19e: Title 40 Code of Federal Regulations Part 60 (40 CFR Part 60)**Subpart OOOOa: Standards of Performance for Crude Oil and Natural Gas Facilities for which Construction, Modification or Reconstruction Commenced After September 18, 2015**

Unit ID No.	SOP/GOP Index No.	Construction/Modification Date	Fugitive Component	AMEL	Alternative GHG and VOC	Subject to Another Regulation
FUG-1	600000a	15+	EQNGPP			NO

[Go to the Table of Contents](#)

Table 19f: Title 40 Code of Federal Regulations Part 60 (40 CFR Part 60)**Subpart OOOOa: Standards of Performance for Crude Oil and Natural Gas Facilities for which Construction, Modification or Reconstruction Commenced After September 18, 2015**

Unit ID No.	SOP/GOP Index No.	Any Vacuum Service	Pumps: Light Liquid Service	Pumps: Design Capacity < 10MM	Pumps: AMEL	Pumps: AMEL ID No.	Pumps: Complying with §60.482-2a
FUG-1	600000a	NO	YES	NO	NO		YES

[Go to the Table of Contents](#)

Table 19g: Title 40 Code of Federal Regulations Part 60 (40 CFR Part 60)

Subpart OOOOa: Standards of Performance for Crude Oil and Natural Gas Facilities for which Construction, Modification or Reconstruction Commenced After September 18, 2015

Unit ID No.	SOP/GOP Index No.	Pressure Relief Devices: Gas/Vapor Service	Pressure Relief Devices: Design Capacity < 10MM	Pressure Relief Devices: AMEL	Pressure Relief Devices: Complying with §60.482-4a
FUG-1	600000a	YES	NO	NO	YES

[Go to the Table of Contents](#)



Table 19h: Title 40 Code of Federal Regulations Part 60 (40 CFR Part 60)

Subpart OOOOa: Standards of Performance for Crude Oil and Natural Gas Facilities for which Construction, Modification or Reconstruction Commenced After September 18, 2015

Unit ID No.	SOP/GOP Index No.	Valves: Open-Ended	Valves: AMEL	Valves: AMEL ID No.	Valves: Complying with §60.482-6a
FUG-1	600000a	YES	NO		YES

[Go to the Table of Contents](#)



Table 19i: Title 40 Code of Federal Regulations Part 60 (40 CFR Part 60)

Subpart OOOOa: Standards of Performance for Crude Oil and Natural Gas Facilities for which Construction, Modification or Reconstruction Commenced After September 18, 2015

Unit ID No.	SOP/GOP Index No.	Valves: Gas/Vapor or Light Liquid Service	Valves: Design Capacity < 10MM	Valves: 2.0%	Valves: AMEL	Valves: AMEL ID No.	Valves: Complying with §60.482-7a
FUG-1	600000a	YES	NO	S	NO		YES

[Go to the Table of Contents](#)

Table 19j: Title 40 Code of Federal Regulations Part 60 (40 CFR Part 60)

Subpart OOOOa: Standards of Performance for Crude Oil and Natural Gas Facilities for which Construction, Modification or Reconstruction Commenced After September 18, 2015

Unit ID No.	SOP/GOP Index No.	Pumps: Heavy Liquid Service	Pumps: AMEL	Pumps: AMEL ID No.	Pumps: Complying with §60.482-8a	Valves: Heavy Liquid Service	Valves: AMEL	Valves: AMEL ID No.	Valves: Complying with §60.482-8a
FUG-1	600000a	YES			YES	YES	NO		YES

[Go to the Table of Contents](#)



Table 19k: Title 40 Code of Federal Regulations Part 60 (40 CFR Part 60)

Subpart OOOOa: Standards of Performance for Crude Oil and Natural Gas Facilities for which Construction, Modification or Reconstruction Commenced After September 18, 2015

Unit ID No.	SOP/GOP Index No.	Pressure Relief Devices: Heavy or Light Liquid Service	Pressure Relief Devices: AMEL	Pressure Relief Devices: AMEL ID No.	Pressure Relief Devices: Complying with §60.482-8a	Connectors: Heavy Liquid Service	Connectors: AMEL	Connectors: AMEL ID No.	Connectors: Complying with §60.482-8a
FUG-1	600000a	YES	NO		YES	YES	NO		YES

[Go to the Table of Contents](#)

Table 19o: Title 40 Code of Federal Regulations Part 60 (40 CFR Part 60)**Subpart OOOOa: Standards of Performance for Crude Oil and Natural Gas Facilities for which Construction, Modification or Reconstruction Commenced After September 18, 2015**

Unit ID No.	SOP/GOP Index No.	Control Devices: CVS	Control Devices: AMEL	Control Devices: AMEL ID No.	Control Devices: Complying with §60.482-10a	Connectors: Gas/Vapor or Light Liquid Service	Connectors: Design Capacity < 10MM	Connectors: AMEL	Connectors: AMEL ID No.	Connectors: Complying with §60.482-11a
FUG-1	600000a	NO				YES	NO	NO		YES

[Go to the Table of Contents](#)

Table 19p: Title 40 Code of Federal Regulations Part 60 (40 CFR Part 60)**Subpart OOOOa: Standards of Performance for Crude Oil and Natural Gas Facilities for which Construction, Modification or Reconstruction Commenced After September 18, 2015**

Unit ID No.	SOP/GOP Index No.	Title 40 CFR Part 60, Subpart OOOOa Fugitive Unit Description
GRP-COMP	600000a	Reciprocating compressor rod packing changer on or before 26000 hrs
FUG-1	60000a	Address requirements for collection of fugitive equipment to include fugitive components such as valves, connector, flanges, pumps, pressure relief devices in vapor , liquid and heavy liquid services
GRP-ELECOMPRES	600000a	Reciprocating compressor rod packing changer on or before 26000 hrs

[Go to the Table of Contents](#)

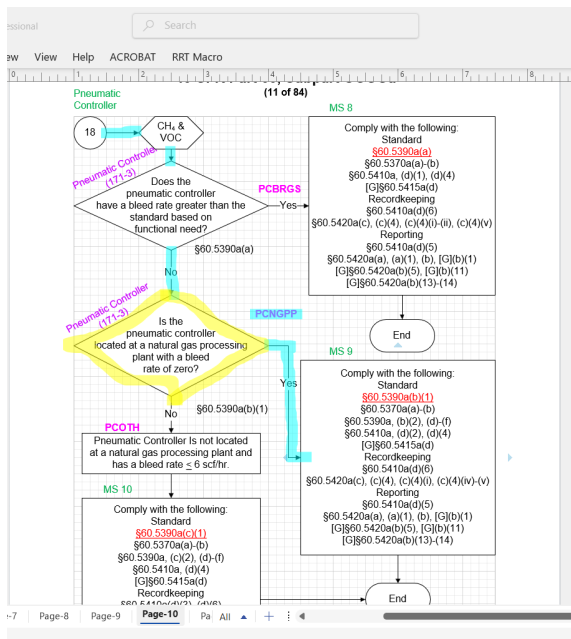

Unit Group Process ID No.	Unit Group Process Type	SOP Index No.	Pollutant	State Rule or Federal Regulation Name	Emission Limitation, Standard or Equipment Specification Citation	Textual Description (See Special Term and Condition 1.B.)	Monitoring And Testing Requirements	Recordkeeping Requirements (30 TAC § 122.144)	Reporting Requirements (30 TAC § 122.145)
FL-4	CD	3-111	Opacity	30 TAC Chapter 111, Visible Emissions	§ 111.111(a)(4)(A)	Visible emissions from a process gas flare shall not be permitted for more than five minutes in any two-hour period. Non-excessive upset events are subject to the provisions under §101.222(b).	§ 111.111(a)(4)(A)(i) § 111.111(a)(4)(A)(ii)	§ 111.111(a)(4)(A)(i) § 111.111(a)(4)(A)(ii)	None
FUG-1	EU	600000a	VOC	40 CFR Part 60, Subpart OOOOa	§ 60.5390a(b)(1) § 60.5370a(a) § 60.5370a(b) § 60.5390a § 60.5390a(b)(2) § 60.5390a(f) § 60.5390a(g)	Each pneumatic controller affected facility at a natural gas processing plant must have a bleed rate of zero.	None	§ 60.5410a(d)(5) § 60.5420a(c) § 60.5420a(c)(4) § 60.5420a(c)(4)(i) § 60.5420a(c)(4)(v) § 60.5420a(c)(4)(v)	§ 60.5410a(d)(5) § 60.5420a(a)(1) § 60.5420a(b)(5) [G] 60.5420a(b)(11) [G] 60.5420a(b)(13)

Renewal Draft Page 28

Arthi Reddy

This pneumatic controllers are not an affected sources as the bleed rate is 0 as it is a natural gas processing plant. However the facility is subject to the requirements for equipment leak and monitoring at the natural gas processing site and therefore this condition should be replaced with 60.5400a. Or revert back to the original general statement for NSPS OOOOa for fugitive similar to the condition in the existing permit.

December 04, 2025, 10:14 AM

Reply

Applicable Requirements Summary

Unit Group Process ID No.	Unit Group Process Type	SOP Index No.	Pollutant	State Rule or Federal Regulation Name	Emission Limitation, Standard or Equipment Specification Citation	Textual Description (See Special Term and Condition 1.B.)	Monitoring And Testing Requirements	Recordkeeping Requirements (30 TAC § 122.144)	Reporting Requirements (30 TAC § 122.145)
					§ 60.5390a(f) § 60.5410a § 60.5410a(d)(2) § 60.5410a(d)(4) [G] 60.5415a(d)				[G] 60.5420a(b)(14) [G] 60.5420a(b)(5)

Let me know if you have any questions and have a great weekend!

Best Regards,

Emily L. Knodell
Permit Reviewer
TCEQ – APD – OP Section (Title V)
(512) 239-3107

How are we doing? Fill out our online customer satisfaction survey at www.tceq.texas.gov/customersurvey

From: Arthi Reddy <Arthi.Reddy@tceq.texas.gov>
Sent: Friday, December 19, 2025 11:13 AM
To: Emily Knodell <Emily.Knodell@tceq.texas.gov>
Cc: Gordon Moore <gordon.moore@tceq.texas.gov>; Gary Mann <magn@brazosmidstream.com>
Subject: RE: Working Draft Permit – FOP O4119/Project 37272, Brazos Midstream Operating, LLC/Comanche Plant

Hi Emily:

Thank for the additional time. I used the new excel formal OP-12 and redid all the tables applicable in the form to address the applicability of NSPS OOOOa at the natural gas plant. The only affected sources are the reciprocating compressor and fugitive monitoring for equipment leaks at the gas plant. All others are not affected sources and the table should reflect the same. I fixed the SOP Index and just used one Index for consistency. Please review and let me know if everything looks good or additional information is needed

Thanks
Arthi

From: Emily Knodell <Emily.Knodell@tceq.texas.gov>
Sent: Thursday, December 18, 2025 2:50 PM
To: Arthi Reddy <Arthi.Reddy@tceq.texas.gov>
Subject: RE: Working Draft Permit – FOP O4119/Project 37272, Brazos Midstream Operating, LLC/Comanche Plant

Hello Arthi,

Thanks for letting me know!

Emily L. Knodell
Permit Reviewer
TCEQ – APD – OP Section (Title V)

(512) 239-3107

How are we doing? Fill out our online customer satisfaction survey at www.tceq.texas.gov/customersurvey

From: Arthi Reddy <Arthi.Reddy@c-ka.com>
Sent: Thursday, December 18, 2025 1:42 PM
To: Emily Knodell <Emily.Knodell@tceq.texas.gov>
Subject: RE: Working Draft Permit -- FOP O4119/Project 37272, Brazos Midstream Operating, LLC/Comanche Plant

Hey Emily:

Just to let you know, I am still working on this. The forms are all new and I am navigating through it to best respond to your email. I will have the forms to you by tomorrow COB. Sorry for the delay.

From: Emily Knodell <Emily.Knodell@tceq.texas.gov>
Sent: Wednesday, December 10, 2025 3:29 PM
To: Arthi Reddy <Arthi.Reddy@c-ka.com>
Cc: Gordon Moore <gordon.moore@c-ka.com>; Gary Mann <mann@brazosmidstream.com>
Subject: Working Draft Permit -- FOP O4119/Project 37272, Brazos Midstream Operating, LLC/Comanche Plant

Sending this again after I realized I needed to update the subject line.

Emily L. Knodell
Permit Reviewer
TCEQ -- APD -- OP Section (Title V)
(512) 239-3107

How are we doing? Fill out our online customer satisfaction survey at www.tceq.texas.gov/customersurvey

From: Emily Knodell
Sent: Wednesday, December 10, 2025 3:27 PM
To: Arthi Reddy <Arthi.Reddy@c-ka.com>
Cc: Gordon Moore <gordon.moore@c-ka.com>; Gary Mann <mann@brazosmidstream.com>
Subject: RE: Technical Review -- FOP O4119/Project 37272, Brazos Midstream Operating, LLC/Comanche Plant

Good afternoon Arthi,

During technical review, the following item was found. Please resolve by **12/17/2025**.

Thank you for providing the update in your 12/04 email.

In regard to your comment on the draft, the requirement for the pneumatic controller is coming from the table you gave me in your original application, Table 19c which is for Pneumatic Controller affected facilities. Are you wanting me to disregard this table and remove that data from our database? Also, it seems that your Index numbers change each time there is a new table. Index numbers are used to differentiate between operating scenarios. If there is only one operating scenario, the same index number should be carried forward throughout the tables until the form instructions indicate that you do not need to continue. Please send me a revised Form OP-UA12 (for all the tables to keep everything together) and make sure it is the latest version (we now have the excel workbook for the OP-UA12). When filling out the workbook and saving it, please keep it in the ".xlsx" format, as this allows me to flip through the pages and table of contents. Also, please follow the form instructions carefully and see what parts actually apply to you as far as what is an affected source. If you can find a UA form from a previous project this might be helpful to use as a reference, but keep in mind that our forms have been updated and now require slightly different answers. Additionally, you sent me the OP-UA12 (Tables 19p) on 12/04. You listed the groups broken up into individual units instead of listing them as groups as we discussed on 06/04. Please also make this correction when you send me all the UA12 Tables together.

Table	Code	Index	Category	Regulation	Requirement	Control	Control	Control
ECF-1	CD	30111	Opacity	30 TAC Chapter 111, Visible Emissions	§ 111.111(a)(4)(A)	Visible emissions from a process gas flare shall not be permitted for more than five minutes in any two-hour period. Non-excessing gaseous emissions are subject to the provisions under §191.222(b).	§ 111.111(a)(4)(A)(i)	§ 111.111(a)(4)(A)(ii)
FL-4	CD	3-111	Opacity	30 TAC Chapter 111, Visible Emissions	§ 111.111(a)(4)(A)	Visible emissions from a process gas flare shall not be permitted for more than five minutes in any two-hour period. Non-excessing gaseous emissions are subject to the provisions under §191.222(b).	§ 111.111(a)(4)(A)(i)	§ 111.111(a)(4)(A)(ii)
FUG1	EU	60000a	VOC	40 CFR Part 60, Subpart OOOOa	§ 60.539a(b)(1) § 60.539a(b)(2) § 60.539a(c) § 60.539a(d) § 60.539a(e)	Each pneumatic controller affected facility at a natural gas processing plant must have a bleed rate of zero.	None	§ 60.541a(d)(6) § 60.542a(c) § 60.542a(c)(4) § 60.542a(c)(4)(v) § 60.542a(c)(4)(v)

Renewal Draft Page 28

Arthi Reddy

This pneumatic controllers are not an affected source as the bleed rate is 0 as it is a natural gas processing plant. However the facility is subject to the requirements for equipment leaks and monitoring at the natural gas processing site and therefore this condition should be replaced with 60.540a. Or revert back to the original general statement for NPS OOOOa for fugitive similar to the condition in the existing permit.

December 04, 2025, 10:14 AM

Reply

Table 19a: Title 40 Code of Federal Regulations Part 60 (40 CFR Part 60) Subpart OOOOa: Standards of Performance for Crude Oil and Natural Gas Facilities for which Construction, Modification or Reconstruction Commenced After September 18, 2015

- ★ Complete Table 19a for Centrifugal Compressor affected facilities.
- ★ Complete Table 19b for Reciprocating Compressor affected facilities.
- ★ **Complete Table 19c for Pneumatic Controller affected facilities.**
- ★ Complete Table 19d for Pneumatic Pump affected facilities.
- ★ Complete Table 19e for the collection of fugitive components located at a well site or compressor station.
- ★ Complete Tables 19e-p for the group of equipment within a process unit located at an onshore natural gas processing plant.

Texas Commission on Environmental Quality
Application Area-Wide Applicability Determinations and General Information
Form OP-REQ1
Federal Operating Permit Program

Date:	04/08/2025
Permit No.:	4119
RN No.:	RN109161745

For SOP applications, answer ALL questions unless otherwise directed.

◆ *For GOP applications, answer ONLY these questions unless otherwise directed.*

Form OP-REQ1: Page 83		
XI. Miscellaneous (continued)		
L. Compliance Assurance Monitoring		
◆	1. The application area includes at least one unit that does not meet the CAM exemptions in 40 CFR § 64.2(b) for all applicable requirements that it is subject to, and the unit has a pre-control device potential to emit greater than or equal to the amount in tons per year required in a site classified as a major source. <i>If the response to Question XI.L.1 is "NO," go to Section XI.M.</i>	<input checked="" type="checkbox"/> YES <input type="checkbox"/> NO
◆	2. The unit or units defined by XI.L.1 are using a control device to comply with an applicable requirement. <i>If the response to Question XI.L.2 is "NO," go to Section XI.M.</i>	<input checked="" type="checkbox"/> YES <input type="checkbox"/> NO
◆	3. The permit holder has submitted a CAM proposal on Form OP-MON in a previous application.	<input checked="" type="checkbox"/> YES <input type="checkbox"/> NO
◆	4. The owner/operator or permit holder is submitting a CAM proposal on Form OP-MON according to the deadlines for submittals in 40 CFR § 64.5 in this application. <i>If the responses to Questions XI.L.3 and XI.L.4 are both "NO," go to Section XI.M.</i>	<input type="checkbox"/> YES <input checked="" type="checkbox"/> NO
	5. The owner/operator or permit holder is submitting a CAM implementation plan and schedule to be incorporated as enforceable conditions in the permit.	<input type="checkbox"/> YES <input checked="" type="checkbox"/> NO
	6. Provide the unit identification numbers for the units for which the applicant is submitting a CAM implementation plan and schedule in the space below.	
◆	7. At least one unit defined by XI.L.1 and XI.L.2 is using a CEMS, COMS or PEMS meeting the requirements of 40 CFR § 64.3(d)(2).	<input type="checkbox"/> YES <input checked="" type="checkbox"/> NO
◆	8. All units defined by XI.L.1 and XI.L.2 are using a CEMS, COMS or PEMS meeting the requirements of 40 CFR § 64.3(d)(2). <i>If the response to Question XI.L.8 is "YES," go to Section XI.M.</i>	<input type="checkbox"/> YES <input checked="" type="checkbox"/> NO

Texas Commission on Environmental Quality
Application Area-Wide Applicability Determinations and General Information
Form OP-REQ1
Federal Operating Permit Program

Date:	04/08/2025
Permit No.:	4119
RN No.:	RN109161745

For SOP applications, answer ALL questions unless otherwise directed.

◆ *For GOP applications, answer ONLY these questions unless otherwise directed.*

Form OP-REQ1: Page 84	
XI. Miscellaneous (continued)	
L. Compliance Assurance Monitoring (continued)	
◆ 9. At least one of the CAM proposals as described by question XI.L.3 or XI.L.4 addresses particulate matter, and the emission unit has a capture system as defined in 40 CFR §64.1.	<input type="checkbox"/> YES <input checked="" type="checkbox"/> NO
◆ 10. At least one of the CAM proposals as described by question XI.L.3 or XI.L.4 addresses VOC, and the emission unit has a capture system as defined in 40 CFR §64.1.	<input checked="" type="checkbox"/> YES <input type="checkbox"/> NO
◆ 11. At least one of the CAM proposals as described by question XI.L.3 or XI.L.4 addresses a regulated pollutant other than particulate matter or VOC, and the emission unit has a capture system as defined in 40 CFR §64.1.	<input type="checkbox"/> YES <input checked="" type="checkbox"/> NO
◆ 12. The control device in the CAM proposal as described by question XI.L.3 or XI.L.4 has a bypass.	<input type="checkbox"/> YES <input checked="" type="checkbox"/> NO
M. Title 30 TAC Chapter 113, Subchapter D, Division 5 - Emission Guidelines and Compliance Times	
◆ 1. The application area includes at least one air curtain incinerator that commenced construction on or before December 9, 2004. <i>If the response to Question XI.M.1 is "NO," or "N/A," go to Section XII.</i>	<input type="checkbox"/> YES <input checked="" type="checkbox"/> NO <input type="checkbox"/> N/A
◆ 2. All air curtain incinerators constructed on or before December 9, 2004 combust only wood waste, clean lumber, or yard waste or a mixture of these materials.	<input type="checkbox"/> YES <input type="checkbox"/> NO
XII. New Source Review (NSR) Authorizations	
A. Waste Permits with Air Addendum	
◆ 1. The application area includes a Municipal Solid Waste Permit or an Industrial Hazardous Waste with an Air Addendum. <i>If the response to XII.A.1 is "YES," include the waste permit numbers and issuance date in Section XII.J.</i>	<input type="checkbox"/> YES <input checked="" type="checkbox"/> NO

**Texas Commission on Environmental Quality
Flare Attributes
Form OP-UA7 (Page 3)
Federal Operating Permit Program**

Table 3: Title 40 Code of Federal Regulations Part 60 and 61 (40 CFR Part 60 and 40 CFR Part 61)

Subpart A: General Provisions of Standards of Performance for New Stationary Sources and National Emission Standards for Hazardous Air Pollutants

Date	Permit No.:	Regulated Entity No.
12/1/2025	4119	RN109161745

Unit ID No.	SOP/GOP Index No.	Subject to 40 CFR §60.18	Adhering to Heat Content Specifications	Flare Assist Type	Flare Exit Velocity	Heating Value of Gas
ECF-1	60A-ECF1	NO				
FL-1	60A-FL1	NO				
FL-2	60A-FL2	NO				
FL-3	60A-FL3	NO				
FL-4	60-FL4	NO				

**Fugitive Emission Unit Attributes
Form OP-UA12 (Page 184)
Federal Operating Permit Program**

**Table 19p: Title 40 Code of Federal Regulations Part 60 (40 CFR Part 60)
Subpart OOOOa: Standards of Performance for Crude Oil and Natural Gas Facilities for which Construction, Modification or Reconstruction
Commenced After September 18, 2015
Texas Commission on Environmental Quality**

Revised - Final Version

Date	Permit No.	Regulated Entity No.
12/1/2005	4119	RN109161745

Unit ID. No.	SOP/GOP Index No.	Title 40 CFR Part 60, Subpart OOOOa Fugitive Unit Components (continued)
		Title 40 CFR Part 60, Subpart OOOOa Fugitive Unit Description
CR-2201; CR-2202; CR-2203; CR-2204	604Oa-RCP1COMP	Reciprocating compressors units at Plant 1
CR-2205; CR-2206; CR-2207; CR-2208	604Oa-RCP2COMP	Reciprocating compressors units at Plant 2
VCOMP-1; VCOMP-2	604Oa-VRUCOMP	Reciprocating compressors units less than 1000 hp
ECR-2212; ECR-2213; ECR-2214; ECF2215	604Oa-ECOMP	Electric compressor units
E-VRUCOM1; E-VRUCOM2; E-VRUCOM3; E-VRUCOM4	604Oa-EVRUCOMP	Electric compressor units

**Fugitive Emission Unit Attributes
Form OP-UA12 (Page 184)
Federal Operating Permit Program**

**Table 19p: Title 40 Code of Federal Regulations Part 60 (40 CFR Part 60)
Subpart OOOOa: Standards of Performance for Crude Oil and Natural Gas Facilities for which Construction, Modification or Reconstruction
Commenced After September 18, 2015
Texas Commission on Environmental Quality**

Date	Permit No.	Regulated Entity No.
12/1/2005	4119	RN109161745

Unit ID. No.	SOP/GOP Index No.	Title 40 CFR Part 60, Subpart OOOOa Fugitive Unit Components (continued)
		Title 40 CFR Part 60, Subpart OOOOa Fugitive Unit Description
CR-2201; CR-2202; CR-2203; CR-2204	604Oa-RCP1COMP	Reciprocating compressors units at Plant 1
CR-2205; CR-2206; CR-2207; CR-2208	604Oa-RCP2COMP	Reciprocating compressors units at Plant 2
VCOMP-1; VCOMP-2	604Oa-VRUCOMP	Reciprocating compressors units less than 1000 hp
ECR-2212; ECR-2213; ECR-2214; ECF2215	604Oa-ECOMP	Electric compressor units
E-VRUCOM1; E-VRUCOM2; E-VRUCOM3; E-VRUCOM4	604Oa-EVRUCOMP	Electric compressor units
FUG-1	604Oa-PNEUCONTR	Sitewide pneumatic controllers at a Plant 1, 2 and 3
FUG-1	604Oa-PNEUPUMP	Sitewide pneumatic pumps at Plant 1, 2 and 3
FUG-1	604Oa-PUMPLL	Sitewide Pumps in light liquid service at Plant 1, 2 and 3
FUG-1	604Oa-PRD	Sitewide Pressure relief devices at Plant 1, 2 and 3
FUG-1	604Oa-VALVEOEL	Sitewide Open-ended line valves at Plant 1, 2 and 3

Fugitive Emission Unit Attributes
 Form OP-4A12 (Page 171)
 Federal Operating Permit Program
 Table 19c: Title 40 Code of Federal Regulations Part 60 (40 CFR Part 60)
 Subpart 0000a: Standards of Performance for Crude Oil and Natural Gas Facilities for which Construction, Modification or Reconstruction
 Commenced After September 18, 2015
 Texas Commission on Environmental Quality

Date	Permit No.	Regulated Entity No.
9/03/2024	4119	RN109161745

Unit ID No.	SOP/GOP Index No.	Construction/Modification Date	Pneumatic Controller
FUG-1	6040a-PNEU/CONTR	15-	PCNGPP

Fugitive Emission Unit Attributes
 Form OP-4A12 (Page 172)
 Federal Operating Permit Program
 Table 19d: Title 40 Code of Federal Regulations Part 60 (40 CFR Part 60)
 Subpart 0000a: Standards of Performance for Crude Oil and Natural Gas Facilities for which Construction, Modification or Reconstruction
 Commenced After September 18, 2015
 Texas Commission on Environmental Quality

Date	Permit No.	Regulated Entity No.
9/03/2024	4119	RN109161745

Unit ID No.	SOP/GOP Index No.	Construction/Modification Date	Pneumatic Pump	Control Option	Control Device ID No.	Bypass Device
FUG-1	6040a-PNEU/PUMP	15-	PNGPP			

Let me know if you have questions.

Best Regards,

Emily L. Knodell
 Permit Reviewer
 TCEQ – APD – OP Section (Title V)
 (512) 239-3107

How are we doing? Fill out our online customer satisfaction survey at www.tceq.texas.gov/customersurvey

From: Arthi Reddy <Arthi.Reddy@tceq.texas.gov>
 Sent: Thursday, December 4, 2025 10:54 AM
 To: Emily Knodell <Emily.Knodell@tceq.texas.gov>
 Cc: Gordon Moore <gordon.moore@tceq.texas.gov>; Gary Mann <mann@brazosmidstream.com>
 Subject: RE: Technical Review -- FOP 04119/Project 37272, Brazos Midstream Operating, LLC/Comanche Plant

Hi Emily:

Please see attached the revised Page 87 to reflect the renewal date for the Standard Permit. I have attached the Working Draft with only comment. Everything else looks OK and similar to the current permit. My comment is with respect to NSPS 0000a condition for fugitives. The facility is subject to the monitoring requirement for equipment leaks under NSPS 0000a at natural gas processing facilities. The pneumatics are not an affected source. I highlighted this with a comment in the attached draft permit.

Please feel free to call or email me if you have any questions.

Thanks
 Arthi

From: Emily Knodell <Emily.Knodell@tceq.texas.gov>
 Sent: Wednesday, December 3, 2025 2:21 PM
 To: Arthi Reddy <Arthi.Reddy@tceq.texas.gov>
 Cc: Gary Mann <mann@brazosmidstream.com>; Gordon Moore <gordon.moore@tceq.texas.gov>
 Subject: RE: Technical Review -- FOP 04119/Project 37272, Brazos Midstream Operating, LLC/Comanche Plant

Good morning Arthi,

Thank you for the updates you sent me on 12/01. Please find attached WDP "Version 2" for your review and/or approval.

Please review the WDP and submit to me any comments you have by **December 17, 2025**, and also resolve the item I listed below by this date.

Summary of Changes:

- Added term 8.E. regarding VOC control device and CAM based on the updated OP-REQ1 (pages 83 & 84) provided on 12/01.
 - Change found on Draft Page 6.
- I modified several SOP Index Nos. which had extensions on them. For example, in the image below, you can see the SOP Index numbers are 60Dc-HMO2, 60Dc-HMO3, 60Dc-HMO4, and 60Dc-HMO5. The "extension" part is what comes after the "-" which I crossed out in pink in the image below. Extensions are used to distinguish different "operating scenarios" for a given unit and applicable rule. Different numbers must be used when entering more than one line of attributes on a Unit Attribute form for the same unit (or group of units) and rule. But since there is only one index number and rule per unit, the extensions are not needed and were therefore removed to avoid confusion. I modeled this after what I saw in the effective permit as well. I highlighted in green text where I modified Index numbers.
 - Changes found on Unit Summary Table (Draft Pages 12-15), Applicable Requirements Summary Table (Draft Pages 17-49).

Boiler/Steam Generator/Steam Generating Unit Attributes
 Form OP-4A6 (Page 11)
 Federal Operating Permit Program
 Table 4a: Title 40 Code of Federal Regulations Part 60 (40 CFR Part 60)
 Subpart De: Standards of Performance for Industrial-Commercial Steam Generating Units
 Texas Commission on Environmental Quality

Date	Permit No.	Regulated Entity No.
9/03/2024	4119	RN109161745

Unit ID No.	SOP Index No.	Construction/Modification Date	Maximum Design Heat Input Capacity	Applicability	Heat Input Capacity	D-Series Fuel Type	D-Series Fuel Type	D-Series Fuel Type	ACF Option SO ₂	ACF Option PM	30% Coal Dust Burner
HMO-2	60Dc-30202	05-	10-100	NONE	30-75	NG			OTHER	OTHER	
HMO-3	60Dc-30203	05-	10-100	NONE	30-75	NG			OTHER	OTHER	
HMO-4	60Dc-30204	05-	10-								
HMO-5	60Dc-30205	05-	10-								

- Removed Unit ID FL-4's 60.18 requirements according to what was provided in Form OP-UA07 (dated 12/01).
- Removed the following Index numbers from Unit ID FUG according to Form OP-UA12 (dated 12/01): 6040a-PNEU/CONTR, 6040a-PNEU/PUMP, 6040a-PUM/PL, 6040a-PRD, 6040a-VALVE/OEL.
- Removed highlighted "Empty" that appeared under the Unit Group Process Type column for some units in the Applicable Requirements Summary Table. This was a data entry error on my end and should now be resolved.
- Form OP-REQ1, Page 87:** For NSR 140834, there is a more recent issuance date listed in IDA, renewal issued 06/25/2025. Would you like to incorporate this date into the renewal? If so, please send an updated Form OP-REQ1, Page 87 which lists the newer date for NSR 140834.

Since this is a follow-up review to the previously submitted and reviewed WDP, only comments concerning changes since the last WDP may be considered by TCEQ. Any comments outside the scope of the most recent changes should be submitted as a separate project.

Best Regards,

Texas Commission on Environmental Quality
Application Area-Wide Applicability Determinations and General Information
Form OP-REQ1
Federal Operating Permit Program

Date:	04/08/2025
Permit No.:	4119
RN No.:	RN109161745

For SOP applications, answer ALL questions unless otherwise directed.

◆ *For GOP applications, answer ONLY these questions unless otherwise directed.*

Form OP-REQ1: Page 83		
XI. Miscellaneous (continued)		
L. Compliance Assurance Monitoring		
◆	1. The application area includes at least one unit that does not meet the CAM exemptions in 40 CFR § 64.2(b) for all applicable requirements that it is subject to, and the unit has a pre-control device potential to emit greater than or equal to the amount in tons per year required in a site classified as a major source. <i>If the response to Question XI.L.1 is "NO," go to Section XI.M.</i>	<input checked="" type="checkbox"/> YES <input type="checkbox"/> NO
◆	2. The unit or units defined by XI.L.1 are using a control device to comply with an applicable requirement. <i>If the response to Question XI.L.2 is "NO," go to Section XI.M.</i>	<input checked="" type="checkbox"/> YES <input type="checkbox"/> NO
◆	3. The permit holder has submitted a CAM proposal on Form OP-MON in a previous application.	<input checked="" type="checkbox"/> YES <input type="checkbox"/> NO
◆	4. The owner/operator or permit holder is submitting a CAM proposal on Form OP-MON according to the deadlines for submittals in 40 CFR § 64.5 in this application. <i>If the responses to Questions XI.L.3 and XI.L.4 are both "NO," go to Section XI.M.</i>	<input type="checkbox"/> YES <input checked="" type="checkbox"/> NO
	5. The owner/operator or permit holder is submitting a CAM implementation plan and schedule to be incorporated as enforceable conditions in the permit.	<input type="checkbox"/> YES <input checked="" type="checkbox"/> NO
	6. Provide the unit identification numbers for the units for which the applicant is submitting a CAM implementation plan and schedule in the space below.	
◆	7. At least one unit defined by XI.L.1 and XI.L.2 is using a CEMS, COMS or PEMS meeting the requirements of 40 CFR § 64.3(d)(2).	<input type="checkbox"/> YES <input checked="" type="checkbox"/> NO
◆	8. All units defined by XI.L.1 and XI.L.2 are using a CEMS, COMS or PEMS meeting the requirements of 40 CFR § 64.3(d)(2). <i>If the response to Question XI.L.8 is "YES," go to Section XI.M.</i>	<input type="checkbox"/> YES <input checked="" type="checkbox"/> NO

Texas Commission on Environmental Quality
Application Area-Wide Applicability Determinations and General Information
Form OP-REQ1
Federal Operating Permit Program

Date:	04/08/2025
Permit No.:	4119
RN No.:	RN109161745

For SOP applications, answer ALL questions unless otherwise directed.

◆ *For GOP applications, answer ONLY these questions unless otherwise directed.*

Form OP-REQ1: Page 84	
XI. Miscellaneous (continued)	
L. Compliance Assurance Monitoring (continued)	
◆ 9. At least one of the CAM proposals as described by question XI.L.3 or XI.L.4 addresses particulate matter, and the emission unit has a capture system as defined in 40 CFR §64.1.	<input type="checkbox"/> YES <input checked="" type="checkbox"/> NO
◆ 10. At least one of the CAM proposals as described by question XI.L.3 or XI.L.4 addresses VOC, and the emission unit has a capture system as defined in 40 CFR §64.1.	<input checked="" type="checkbox"/> YES <input type="checkbox"/> NO
◆ 11. At least one of the CAM proposals as described by question XI.L.3 or XI.L.4 addresses a regulated pollutant other than particulate matter or VOC, and the emission unit has a capture system as defined in 40 CFR §64.1.	<input type="checkbox"/> YES <input checked="" type="checkbox"/> NO
◆ 12. The control device in the CAM proposal as described by question XI.L.3 or XI.L.4 has a bypass.	<input type="checkbox"/> YES <input checked="" type="checkbox"/> NO
M. Title 30 TAC Chapter 113, Subchapter D, Division 5 - Emission Guidelines and Compliance Times	
◆ 1. The application area includes at least one air curtain incinerator that commenced construction on or before December 9, 2004. <i>If the response to Question XI.M.1 is "NO," or "N/A," go to Section XII.</i>	<input type="checkbox"/> YES <input checked="" type="checkbox"/> NO <input type="checkbox"/> N/A
◆ 2. All air curtain incinerators constructed on or before December 9, 2004 combust only wood waste, clean lumber, or yard waste or a mixture of these materials.	<input type="checkbox"/> YES <input type="checkbox"/> NO
XII. New Source Review (NSR) Authorizations	
A. Waste Permits with Air Addendum	
◆ 1. The application area includes a Municipal Solid Waste Permit or an Industrial Hazardous Waste with an Air Addendum. <i>If the response to XII.A.1 is "YES," include the waste permit numbers and issuance date in Section XII.J.</i>	<input type="checkbox"/> YES <input checked="" type="checkbox"/> NO

**Texas Commission on Environmental Quality
Flare Attributes
Form OP-UA7 (Page 3)
Federal Operating Permit Program**

Table 3: Title 40 Code of Federal Regulations Part 60 and 61 (40 CFR Part 60 and 40 CFR Part 61)

Subpart A: General Provisions of Standards of Performance for New Stationary Sources and National Emission Standards for Hazardous Air Pollutants

Date	Permit No.:	Regulated Entity No.
12/1/2025	4119	RN109161745

Unit ID No.	SOP/GOP Index No.	Subject to 40 CFR §60.18	Adhering to Heat Content Specifications	Flare Assist Type	Flare Exit Velocity	Heating Value of Gas
ECF-1	60A-ECF1	NO				
FL-1	60A-FL1	NO				
FL-2	60A-FL2	NO				
FL-3	60A-FL3	NO				
FL-4	60-FL4	NO				

**Fugitive Emission Unit Attributes
Form OP-UA12 (Page 184)
Federal Operating Permit Program**

**Table 19p: Title 40 Code of Federal Regulations Part 60 (40 CFR Part 60)
Subpart OOOOa: Standards of Performance for Crude Oil and Natural Gas Facilities for which Construction, Modification or Reconstruction
Commenced After September 18, 2015
Texas Commission on Environmental Quality**

Revised - Final Version

Date	Permit No.	Regulated Entity No.
12/1/2005	4119	RN109161745

Unit ID. No.	SOP/GOP Index No.	Title 40 CFR Part 60, Subpart OOOOa Fugitive Unit Components (continued)
		Title 40 CFR Part 60, Subpart OOOOa Fugitive Unit Description
CR-2201; CR-2202; CR-2203; CR-2204	604Oa-RCP1COMP	Reciprocating compressors units at Plant 1
CR-2205; CR-2206; CR-2207; CR-2208	604Oa-RCP2COMP	Reciprocating compressors units at Plant 2
VCOMP-1; VCOMP-2	604Oa-VRUCOMP	Reciprocating compressors units less than 1000 hp
ECR-2212; ECR-2213; ECR-2214; ECF2215	604Oa-ECOMP	Electric compressor units
E-VRUCOM1; E-VRUCOM2; E-VRUCOM3; E-VRUCOM4	604Oa-EVRUCOMP	Electric compressor units

**Fugitive Emission Unit Attributes
Form OP-UA12 (Page 184)
Federal Operating Permit Program**

**Table 19p: Title 40 Code of Federal Regulations Part 60 (40 CFR Part 60)
Subpart OOOOa: Standards of Performance for Crude Oil and Natural Gas Facilities for which Construction, Modification or Reconstruction
Commenced After September 18, 2015
Texas Commission on Environmental Quality**

Date	Permit No.	Regulated Entity No.
12/1/2005	4119	RN109161745

Unit ID. No.	SOP/GOP Index No.	Title 40 CFR Part 60, Subpart OOOOa Fugitive Unit Components (continued)
		Title 40 CFR Part 60, Subpart OOOOa Fugitive Unit Description
CR-2201; CR-2202; CR-2203; CR-2204	604Oa-RCP1COMP	Reciprocating compressors units at Plant 1
CR-2205; CR-2206; CR-2207; CR-2208	604Oa-RCP2COMP	Reciprocating compressors units at Plant 2
VCOMP-1; VCOMP-2	604Oa-VRUCOMP	Reciprocating compressors units less than 1000 hp
ECR-2212; ECR-2213; ECR-2214; ECF2215	604Oa-ECOMP	Electric compressor units
E-VRUCOM1; E-VRUCOM2; E-VRUCOM3; E-VRUCOM4	604Oa-EVRUCOMP	Electric compressor units
FUG-1	604Oa-PNEUCONTR	Sitewide pneumatic controllers at a Plant 1, 2 and 3
FUG-1	604Oa-PNEUPUMP	Sitewide pneumatic pumps at Plant 1, 2 and 3
FUG-1	604Oa-PUMPLL	Sitewide Pumps in light liquid service at Plant 1, 2 and 3
FUG-1	604Oa-PRD	Sitewide Pressure relief devices at Plant 1, 2 and 3
FUG-1	604Oa-VALVEOEL	Sitewide Open-ended line valves at Plant 1, 2 and 3

Emily L. Knodell
 Permit Reviewer
 TCEQ – APD – OP Section (Title V)
 (512) 239-3107

How are we doing? Fill out our online customer satisfaction survey at www.tceq.texas.gov/customersurvey

From: Arthi Reddy <Arthi.Reddy@c-ka.com>
Sent: Monday, December 1, 2025 1:41 PM
To: Emily Knodell <Emily.Knodell@tceq.texas.gov>
Cc: Gary Mann (<mann@brazosmidstream.com>); Gordon Moore (<gordon.moore@c-ka.com>);
Subject: RE: Technical Review -- FOP 04119/Project 37272, Brazos Midstream Operating, LLC/Comanche Plant

Hi Emily:

Hope you are doing good. Please see the attached revised information to reflect the comments in your email below.
 On OP-REQ1, I changed the CAM responses same as the previous application.
 Revised the OP-UA7 and OP-UA12 to delete the highlighted as per your email request.

Please review and let me know if you have any questions or need additional informations

Thanks
 Arthi

From: Emily Knodell <Emily.Knodell@tceq.texas.gov>
Sent: Wednesday, November 26, 2025 10:38 AM
To: Arthi Reddy <Arthi.Reddy@c-ka.com>
Cc: Gary Mann (<mann@brazosmidstream.com>); Gordon Moore (<gordon.moore@c-ka.com>);
Subject: RE: Technical Review -- FOP 04119/Project 37272, Brazos Midstream Operating, LLC/Comanche Plant

Good afternoon Arthi,

Sorry for the delay in my response. Please see my responses to your questions below. I am including screenshots of your comments as well as application forms for our ease of reference. Please resolve these items by **12/03/2025**.

1. **Comment No. 1 - CAM condition:** permit conditions are generated based on how the application OP-REQ1 is answered. Please re-review the section which relates to CAM and make sure it is answered correctly. It looks like Page 83, X1.L.5. needs an answer. You may also want to review how Form OP-REQ1 was answered in previous applications.

7. The permit holder shall comply with certified registrations submitted to the TCEQ for purposes of establishing federally enforceable emission limits. A copy of the certified registration shall be maintained with the permit. Records sufficient to demonstrate compliance with the established limits shall be maintained. The certified registration and records demonstrating compliance shall be provided, on request, to representatives of the appropriate TCEQ regional office and any local air pollution control agency having jurisdiction over the site. The permit holder shall submit updated certified registrations when changes at the site require establishment of new emission limits. If changes result in emissions that do not remain below major source thresholds, the permit holder shall submit a revision application to codify the appropriate requirements in the permit.

Additional Monitoring Requirements

8. Unless otherwise specified, the permit holder shall comply with the compliance assurance monitoring requirements as specified in the attached "CAM Summary" upon issuance of the permit. In addition, the permit holder shall comply with the following:

A. The permit holder shall comply with the terms and conditions contained in 30 TAC § 122.147 (General Terms and Conditions for Compliance Assurance Monitoring).

B. The permit holder shall report, consistent with the averaging time identified in the "CAM Summary," deviations as defined by the deviation limit in the "CAM Summary." Any monitoring data below a minimum limit or above a maximum limit, that is collected in

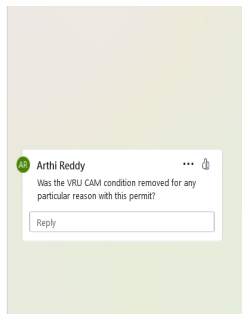

Form OP-REQ1: Page 83		
XI. Miscellaneous (continued)		
I. Compliance Assurance Monitoring		
1.	The application area includes at least one unit that does not meet the CAM exemptions in 40 CFR § 64.2(b) for all applicable requirements that it is subject to, and the unit has a pre-control device potential to emit greater than or equal to the amount in tons per year required in a site classified as a major source. <i>If the response to Question X1.L.1 is "NO," go to Section XI.M.</i>	<input checked="" type="checkbox"/> YES <input type="checkbox"/> NO
2.	The unit or units defined by X1.L.1 are using a control device to comply with an applicable requirement. <i>If the response to Question X1.L.2 is "NO," go to Section XI.M.</i>	<input checked="" type="checkbox"/> YES <input type="checkbox"/> NO
3.	The permit holder has submitted a CAM proposal on Form OP-MON in a previous application.	<input checked="" type="checkbox"/> YES <input type="checkbox"/> NO
4.	The owner/operator or permit holder is submitting a CAM proposal on Form OP-MON according to the deadlines for submittals in 40 CFR § 64.5 in this application. <i>If the responses to Questions X1.L.3 and X1.L.4 are both "NO," go to Section XI.M.</i>	<input type="checkbox"/> YES <input checked="" type="checkbox"/> NO
5.	The owner/operator or permit holder is submitting a CAM implementation plan and schedule to be incorporated as enforceable conditions in the permit.	<input type="checkbox"/> YES <input type="checkbox"/> NO
6.	Provide the unit identification numbers for the units for which the applicant is submitting a CAM implementation plan and schedule in the space below.	
7.	At least one unit defined by X1.L.1 and X1.L.2 is using a CEMS, COMS or PEMS meeting the requirements of 40 CFR § 64.3(d)(2).	<input type="checkbox"/> YES <input type="checkbox"/> NO
8.	All units defined by X1.L.1 and X1.L.2 are using a CEMS, COMS or PEMS meeting the requirements of 40 CFR § 64.3(d)(2). <i>If the response to Question X1.L.8 is "YES," go to Section XI.M.</i>	<input type="checkbox"/> YES <input type="checkbox"/> NO

2. **Comment No. 2 – Flare & NSPS Sources:** This is related to what was filled out in the application Form OP-UA7. The answer "Yes" was selected for the third column "Subject to 40 CFR 60.18" for Unit ID FL-4 and therefore 60.18 requirements were generated. Please send a revised OP-UA7.

Unit ID No.	Unit Group Process ID No.	SOP Index No.	Pollutant	State Rule or Federal Registration Name	Emission Limitation, Standard or Equipment Specification Citation	Textual Description (See Special Term and Condition 1.B.)	Monitoring And Testing Requirements	Recording/Reporting Requirements	Reporting Requirements
ECF-1	CD	3011-ECF1	Opacity	30 TAC Chapter 111, Visible Emissions	§ 111.111(a)(4)(A)	Visible emissions from a process gas flare shall not be permitted for more than five minutes in any two-hour period. Non-accrual events are subject to the provisions under §101.22(b).	§ 111.111(a)(4)(A)(i) § 111.111(a)(4)(A)(ii)	§ 111.111(a)(4)(A)(i) § 111.111(a)(4)(A)(ii)	None
FL-4	CD	3-11-FL4	Opacity	30 TAC Chapter 111, Visible Emissions	§ 111.111(a)(4)(A)	Visible emissions from a process gas flare shall not be permitted for more than five minutes in any two-hour period. Non-accrual events are subject to the provisions under §101.22(b).	§ 111.111(a)(4)(A)(i) § 111.111(a)(4)(A)(ii)	§ 111.111(a)(4)(A)(i) § 111.111(a)(4)(A)(ii)	None
FL-4	CD	65-FL4	Opacity	40 CFR Part 60, Subpart A	§ 60.30(b) § 60.30(c)(1) § 60.30(c)(2) § 60.30(c)(3) § 60.30(c)(4) § 60.30(c)(5) § 60.30(c)(6)	Flares shall comply with paragraph (c) of § 60.30.	§ 60.30(d) § 60.30(e)(1) § 60.30(e)(2) § 60.30(e)(3) § 60.30(e)(4)	None	

Arthi Reddy

The flare does not control any NSPS affected sources.

Reply

Applicable Requirements Summary
 Form OP-1A12 (Page 3)
 Federal Operating Permit Program
 Table 3: Title 40 Code of Federal Regulations Part 60 and 41 (40 CFR Part 60 and 40 CFR Part 61)
 Subpart A: General Provisions of Standards of Performance for New Stationary Sources and National Emission Standards for Hazardous Air Pollutants

Date	Permit No.	Regulated Entity No.
9/03/2024	4119	RN109161745

Unit ID No.	SOP/GOP Index No.	Subject to 40 CFR §60.18	Adhering to Heat Content Specifications	Flare Assist Type	Flare Exit Velocity	Heating Value of Gas
ECF-1	60A-ECF1	NO	NO			
FL-1	60A-FL1	NO	NO			
FL-2	60A-FL2	NO	NO			
FL-3	60A-FL3	NO	NO			
FL-4	60-FL4	YES	YES	AIR		

3. **Comment No. 3 – Fugitive NSPS OOOOa Applicability.** I looked at the effective permit and see GRP-COMP_OOOOa and GRP-ELECOMPRESS listed in the Applicable Requirements Summary Table and their unit type as fugitive emission units. In order to represent this as it is in the effective permit, please send a revised OP-1A12 which removes the other index numbers (highlighted below). It is helpful to me if you use the strikethrough feature in MS word to let me know what information you want to be taken out of the database.

Unit Group Process ID No.	Unit Group Process Type	SOP Index No.	Pollutant	State Rule or Federal Registration Name	Emission Limitation, Standard or Equipment Specification Citation	Textual Description (See Special Term and Condition 1.B.)	Monitoring And Testing Requirements	Recording/Reporting Requirements	Reporting Requirements
FLG-1	Emp	60A-FCMUCO VTC	VOC	40 CFR Part 60, Subpart OOOOa	§ 60.535(a)(1) § 60.535(a)(2) § 60.535(a)(3) § 60.535(a)(4) § 60.535(a)(5) § 60.535(a)(6) § 60.535(a)(7) § 60.535(a)(8)	For each reciprocating compressor, the owner or operator must replace the rod packing on an existing compressor as operated for 20,000 hours. The number of hours of operation must be continuously monitored beginning upon initial startup of your reciprocating compressor affected facility. August 2, 2015, or the date of the most recent reciprocating compressor rod packing replacement, whichever is later.	§ 60.541(a)(1) § 60.541(a)(2) § 60.541(a)(3)	§ 60.541(a)(1) § 60.541(a)(2) § 60.541(a)(3) § 60.541(a)(4) § 60.541(a)(5) § 60.541(a)(6) § 60.541(a)(7) § 60.541(a)(8)	§ 60.541(a)(1) § 60.541(a)(2) § 60.541(a)(3) § 60.541(a)(4) § 60.541(a)(5) § 60.541(a)(6) § 60.541(a)(7) § 60.541(a)(8)
FLG-1	Emp	60A-FCMUCO VTC	VOC	40 CFR Part 60, Subpart OOOOa	§ 60.535(a)(1) § 60.535(a)(2) § 60.535(a)(3) § 60.535(a)(4) § 60.535(a)(5) § 60.535(a)(6) § 60.535(a)(7) § 60.535(a)(8)	For each reciprocating compressor, the owner or operator must replace the rod packing on an existing compressor as operated for 20,000 hours. The number of hours of operation must be continuously monitored beginning upon initial startup of your reciprocating compressor affected facility. August 2, 2015, or the date of the most recent reciprocating compressor rod packing replacement, whichever is later.	§ 60.541(a)(1) § 60.541(a)(2) § 60.541(a)(3)	§ 60.541(a)(1) § 60.541(a)(2) § 60.541(a)(3) § 60.541(a)(4) § 60.541(a)(5) § 60.541(a)(6) § 60.541(a)(7) § 60.541(a)(8)	§ 60.541(a)(1) § 60.541(a)(2) § 60.541(a)(3) § 60.541(a)(4) § 60.541(a)(5) § 60.541(a)(6) § 60.541(a)(7) § 60.541(a)(8)
FLG-1	Emp	60A-FCMUCO VTC	VOC	40 CFR Part 60, Subpart OOOOa	§ 60.535(a)(1) § 60.535(a)(2) § 60.535(a)(3) § 60.535(a)(4) § 60.535(a)(5) § 60.535(a)(6) § 60.535(a)(7) § 60.535(a)(8)	For each reciprocating compressor, the owner or operator must replace the rod packing on an existing compressor as operated for 20,000 hours. The number of hours of operation must be continuously monitored beginning upon initial startup of your reciprocating compressor affected facility. August 2, 2015, or the date of the most recent reciprocating compressor rod packing replacement, whichever is later.	§ 60.541(a)(1) § 60.541(a)(2) § 60.541(a)(3)	§ 60.541(a)(1) § 60.541(a)(2) § 60.541(a)(3) § 60.541(a)(4) § 60.541(a)(5) § 60.541(a)(6) § 60.541(a)(7) § 60.541(a)(8)	§ 60.541(a)(1) § 60.541(a)(2) § 60.541(a)(3) § 60.541(a)(4) § 60.541(a)(5) § 60.541(a)(6) § 60.541(a)(7) § 60.541(a)(8)

Arthi Reddy

Regarding the applicability of NSPS OOOOa for fugitives, the condition for rod packing change applies to the compressor that is GRP-COMP_OOOOa and GRP-ELECOMPRESS. The fugitives are subject to the nearby monitoring. This is confusing due to the representation of the OOOOa requirements in the OOOOa table in the new UA-FUG form, can we please just revert back to the condition for fugitives in the current SOP Permit. This applies to all ES that show empty. ASA 8/30/24

August 29, 2024, 9:07 AM

Reply

Applicable Requirements Summary
 Form OP-1A12 (Page 184)
 Federal Operating Permit Program
 Table 19: Title 40 Code of Federal Regulations Part 60 (40 CFR Part 60)
 Subpart OOOOa: Standards of Performance for Crude Oil and Natural Gas Facilities for which Construction, Modification or Reconstruction Commenced After September 18, 2015
 Texas Commission on Environmental Quality

Date	Permit No.	Regulated Entity No.
6/4/2025	4119	RN109161745

Unit ID No.	SOP/GOP Index No.	Title 40 CFR Part 60, Subpart OOOOa Fugitive Unit Description
GRP-COMP_OOOOa	6040a-RCP/COMP	Reciprocating compressors units at Plant 1
GRP-COMP_OOOOa	6040a-RCP/COMP	Reciprocating compressors units at Plant 2
GRP-COMP_OOOOa	6040a-EVRCOMP	Reciprocating compressors units less than 1000 hp
GRP-ELECOMPRESS	6040a-EVRCOMP	Electric compressor units
GRP-ELECOMPRESS	6040a-EVRCOMP	Electric compressor units
FUG-1	6040a-PNEUMCONTR	Sidekick pneumatic controllers at Plant 1, 2 and 3
FUG-1	6040a-PNEUMCONTR	Sidekick pneumatic pumps at Plant 1, 2 and 3
FUG-1	6040a-PNEUMCONTR	Sidekick Pumps in light liquid service at Plant 1, 2 and 3
FUG-1	6040a-PRD	Sidekick Pressure relief devices at Plant 1, 2 and 3
FUG-1	6040a-VALVEOEL	Sidekick Open ended line valves at Plant 1, 2 and 3

Arthi Reddy

Just want to confirm for FUG from the existing SOP

Reply

Let me know if you have any questions. I wish you all a Happy Thanksgiving!

Best Regards,

**Texas Commission on Environmental Quality
Miscellaneous Unit Attributes
Form OP-UA1 (Page 1)
Federal Operating Permit Program**

Date:	Updated 7/7/2024
Permit No.:	4119
Regulated Entity No.:	RN109161745

Unit ID No.	SOP/GOP Index No.	Unit Type	Date Constructed/Placed in Service	Functionally Identical Replacement	Maximum Rated Capacity	Technical Information and Unit Description
LOAD2-CONDENSATE	64CAM-LOADCON2	EP	8/01/2017			Plant 2 Condensate Loading point
TO-1A		CD	10/02/2019			Plant 1 Thermal Oxidizer
TO-2		CD	8/01/2017			Plant 2 Thermal Oxidizer
TO-3		CD	4/10/2018			Plant 3 Thermal Oxidizer

Emily L. Knodell
Permit Reviewer
TCEQ – APD – OP Section (Title V)
(512) 239-3107

 How are we doing? Fill out our online customer satisfaction survey at www.tceq.texas.gov/customersurvey

From: Arthi Reddy <Arthi.Reddy@c-ka.com>
Sent: Thursday, September 4, 2025 8:44 AM
To: Emily Knodell <Emily.Knodell@tceq.texas.gov>
Cc: Gary Mann <mann@brazosmidstream.com>; Gordon Moore <gordon.moore@c-ka.com>
Subject: RE: Technical Review -- FOP O4119/Project 37272, Brazos Midstream Operating, LLC/Comanche Plant

Hi Emily:

Please see attached our comments for the working draft permit. Please call or email me if you have any questions or need any additional information.

Thanks
Arthi

From: Emily Knodell <Emily.Knodell@tceq.texas.gov>
Sent: Wednesday, August 6, 2025 10:56 AM
To: Arthi Reddy <Arthi.Reddy@c-ka.com>
Cc: Gary Mann <mann@brazosmidstream.com>; Gordon Moore <gordon.moore@c-ka.com>
Subject: RE: Technical Review -- FOP O4119/Project 37272, Brazos Midstream Operating, LLC/Comanche Plant

Good morning all,

I have conducted a technical review of *renewal* application for **Brazos Midstream Operating, LLC/Comanche Plant**. An electronic copy of the Working Draft Permit (WDP) is attached for your review. This WDP contains the TCEQ determination of applicable requirements based on the information submitted in your application, and any updates provided.

Please review the WDP and submit to me any comments you have by **September 5, 2025**.

Please submit a written response by this deadline, even if you are not making any comments on the content of the WDP.

Please review the second portion of the "SOP Technical Review Fact Sheet" located at http://www.tceq.texas.gov/assets/public/permitting/air/Guidance/Title_V/sop_wdp_factsheet.pdf. This guidance contains important information regarding WDP review and comment procedures.

Note that a Certification by Responsible Official (Form OP-CRO1) for any uncertified application information, including application updates supporting the WDP comments, is required. After final review of the WDP, additional changes supported by application updates may require certification. I will advise you of these changes at a later date. Prior to transmittal of the Public Notice/Announcement Authorization Package, a duly signed OP-CRO1 form may be required which includes the specific dates or time-period of all submitted application documentation that was not previously certified. I will advise you of this requirement prior to sending the Public Notice/Announcement Authorization.

Application updates may now be submitted through Title V STEERS. Any application updates that are submitted by the RO/DAR through STEERS are certified and do not require the submittal of an original signature OP-CRO1. Application updates that are provided through email or physical mail require certification using an original signature OP-CRO1.

Please notify me when these updates have been submitted.

As required on Form OP-1, question IV.D, please remember the FOP application and all application updates must be submitted to EPA Region 6 at R6AirPermitsTX@epa.gov and to the TCEQ regional office having jurisdiction. This submittal information can be found on our website at [Where to Submit FOP Applications and Permit-Related Documents](#).

Contact me if you have any questions regarding the guidelines, the project schedule, or any other details regarding your application or permit.

Thank you for your cooperation.

Sincerely,

Emily L. Knodell
Permit Reviewer
TCEQ – APD – OP Section (Title V)
(512) 239-3107

 How are we doing? Fill out our online customer satisfaction survey at www.tceq.texas.gov/customersurvey

From: Emily Knodell
Sent: Thursday, July 10, 2025 9:24 AM
To: Arthi Reddy <Arthi.Reddy@c-ka.com>
Cc: Gary Mann <mann@brazosmidstream.com>; Gordon Moore <gordon.moore@c-ka.com>
Subject: RE: Technical Review -- FOP O4119/Project 37272, Brazos Midstream Operating, LLC/Comanche Plant

Received, thank you!

Emily L. Knodell
Permit Reviewer
TCEQ – APD – OP Section (Title V)
(512) 239-3107

 How are we doing? Fill out our online customer satisfaction survey at www.tceq.texas.gov/customersurvey

From: Arthi Reddy <Arthi.Reddy@c-ka.com>
Sent: Monday, July 7, 2025 4:01 PM
To: Emily Knodell <Emily.Knodell@tceq.texas.gov>
Cc: Gary Mann <mann@brazosmidstream.com>; Gordon Moore <gordon.moore@c-ka.com>
Subject: RE: Technical Review -- FOP O4119/Project 37272, Brazos Midstream Operating, LLC/Comanche Plant

Hi Emily:

Hope you are doing well. Please see attached the OP-UA 1 form . Please let me know if you need anything else.

Thanks
Arthi

From: Emily Knodell <Emily.Knodell@tceq.texas.gov>
Sent: Friday, June 27, 2025 1:44 PM
To: Arthi Reddy <Arthi.Reddy@c-ka.com>
Cc: Gary Mann <mann@brazosmidstream.com>; Gordon Moore <gordon.moore@c-ka.com>
Subject: RE: Technical Review -- FOP O4119/Project 37272, Brazos Midstream Operating, LLC/Comanche Plant

Good afternoon Arthi,

Thank you for providing the updates. Could you please also send over Form OP-UA1? I do see all the other forms attached in you 06/06 email just not this one.

Thank you & have a great weekend!

**Federal Operating Permit Program
 Application for Permit Revision/Renewal
 Form OP-2-Table 1
 Texas Commission on Environmental Quality**

Date: 6/6/2025	
Permit No.: 4119	
Regulated Entity No.: RN109161745	
Company Name: Comanche Plant	
For Submissions to EPA	
Has an electronic copy of this application been submitted (or is being submitted) to EPA? <input checked="" type="checkbox"/> YES <input type="checkbox"/> NO	
I. Application Type	
Indicate the type of application:	
<input checked="" type="checkbox"/> Renewal	
<input checked="" type="checkbox"/> Streamlined Revision (Must include provisional terms and conditions as explained in the instructions.)	
<input type="checkbox"/> Significant Revision	
<input type="checkbox"/> Revision Requesting Prior Approval	
<input type="checkbox"/> Administrative Revision	
<input type="checkbox"/> Response to Reopening	
II. Qualification Statement	
For SOP Revisions Only	<input checked="" type="checkbox"/> YES <input type="checkbox"/> NO
For GOP Revisions Only	<input type="checkbox"/> YES <input type="checkbox"/> NO

**Federal Operating Permit Program
Application for Permit Revision/Renewal
Form OP-2-Table 1 (continued)
Texas Commission on Environmental Quality**

III. Major Source Pollutants (Complete this section if the permit revision is due to a change at the site or change in regulations.)

Indicate all pollutants for which the site is a major source based on the site's potential to emit:
(Check the appropriate box[es].)

VOC NO_x SO₂ PM₁₀ CO Pb HAP

Other:

IV. Reference Only Requirements (For reference only)

Has the applicant paid emissions fees for the most recent agency fiscal year (September 1 - August 31)? YES NO N/A

V. Delinquent Fees and Penalties

Notice: This form will not be processed until all delinquent fees and/or penalties owed to the TCEQ or the Office of the Attorney General on behalf of the TCEQ are paid in accordance with the Delinquent Fee and penalty protocol.

**Federal Operating Permit Program
Application for Permit Revision/Renewal
Form OP-2-Table 2
Texas Commission on Environmental Quality**

Date: 6/6/2025
Permit No.: 4119
Regulated Entity No.: RN109161745
Company Name: Brazos Midstream Operating LLC

Using the table below, provide a description of the revision.

Revision No.	Revision Code	New Unit	Unit/Group	Process	NSR Authorization	Description of Change and Provisional Terms and Conditions
			ID No.	Applicable Form		
1	MS-C	NO	CR-2209	OP-UA2	140834	The unit has been removed from the site
2	MS-C	NO	CR-2210	OP-UA2	140834	The unit has been removed from the site
3	MS-C	NO	CR-2211	OP-UA2	140834	The unit has been removed from the site.
4	MS-C	NO	LOAD3- CNDNDATE	OP-UA1	140834	This emission point does not exist any longer.
5	MS-C	NO	TO-1A	OP-UA1	140834	No changing attributes except to add the emission unit to the Title V database.
6	MS-C	NO	TO-2	OP-UA1	140834	No changing attributes except to add the emission unit to the Title V database.
7	MS-C	NO	TO-3	OP-UA1	140834	No changing attributes except to add the emission unit to the Title V database.

**Federal Operating Permit Program
Application for Permit Revision/Renewal
Form OP-2-Table 3
Texas Commission on Environmental Quality**

Date: 4/12/2024	
Permit No.:4119	
Regulated Entity No.: RN109161745	
Company Name: Brazos Midstream Operating LLC	
I. Significant Revision <i>(Complete this section if you are submitting a significant revision application or a renewal application that includes a significant revision.)</i>	
A. Is the site subject to bilingual requirements pursuant to 30 TAC § 122.322?	<input type="checkbox"/> YES <input type="checkbox"/> NO
B. Indicate the alternate language(s) in which public notice is required:	
C. Will, there be a change in air pollutant emissions as a result of the significant revision?	<input type="checkbox"/> YES <input type="checkbox"/> NO

Permit By Rule Supplemental Table (Page 1)
Table A: Registered Permits by Rule (30 TAC Chapter 106) for the Application Area
Texas Commission on Environmental Quality

Date	Permit Number	Regulated Entity Number
6/6/2025	4119	

Unit ID No.	Registration No.	PBR No.	Registration Date
N/A	N/A	N/A	N/A

Permit By Rule Supplemental Table (Page 2)
Table B: Claimed (not registered) Permits by Rule (30 TAC Chapter 106) for the Application Area
Texas Commission on Environmental Quality

Date	Permit Number	Regulated Entity Number
6/6/2025	4119	RN109161745

Unit ID No.	PBR No.	Version No./Date
MSS-COMP-BLD	106.359	Version No.1/Sept 10, 2013
MSS-VSS-BLD	106.359	Version No.1/Sept 10, 2013
MSS-TKC	106.359	Version No.1/Sept 10, 2013
MSS-DEFAULT	106.359	Version No.1/Sept 10, 2013
MSS-P&B	106.359	Version No.1/Sept 10, 2013
MSS-OTHER	106.359	Version No.1/Sept 10, 2013
PBR SUBPART U STORAGE TANKS	106.472; 106.473	Version No.2/Sept 4, 2000
GEN-1; GEN-2; GEN-3; GEN-4 and GEN-5	106.511	Version No.2/Sept 4, 2000

Permit By Rule Supplemental Table (Page 3)
Table C: Claimed (not registered) Permits by Rule (30 TAC Chapter 106) for Insignificant Sources for the Application Area
Texas Commission on Environmental Quality

Date	Permit Number	Regulated Entity Number
6/6/2025	4119	RN109161745

PBR No.	Version No./Date
N/A	N/A

Permit By Rule Supplemental Table (Page 4)
Table D: Monitoring Requirements for registered and claimed PBRs for the Application Area
Texas Commission on Environmental Quality

Date	Permit Number	Regulated Entity Number
6/6/2025	4119	RN109161745

Unit ID No.	PBR No.	Version No./Date Or Registration No.	Monitoring Requirement
MSS-COMP-BLD	106.359	Version No.1/Sept 10, 2013	Records of conducted planned MSS activities for compressor blowdowns and actual emissions not to exceed the limits in PBR 106.4(a).
MSS-VSS-BLD	106.359	Version No.1/Sept 10, 2013	Records of conducted planned MSS activities for vessel blowdowns and actual emissions not to exceed the limits in PBR 106.4(a).
MSS-TKC	106.359	Version No.1/Sept 10, 2013	Records of conducted planned MSS activities for tank cleaning and purging and actual emissions not to exceed the limits in PBR 106.4(a).
MSS-DEFAULT	106.359	Version No.1/Sept 10, 2013	Records of conducted planned MSS activities and actual emissions not to exceed the limits in PBR 106.4(a).
MSS-P&B	106.359	Version No.1/Sept 10, 2013	Records of conducted planned MSS activities and actual emissions not to exceed the limits in PBR 106.4(a).
MSS-OTHER	106.359	Version No.1/Sept 10, 2013	Records of conducted planned MSS activities and actual emissions not to exceed the limits in PBR 106.4(a).
PBR SUBPART U STORAGE TANKS	106.472; 106.473	Version No.2/Sept 4, 2000	Records of throughputs and chemicals loading/unloading and actual emissions not to exceed the limits in PBR 106.4(a)
GEN-1; GEN-2; GEN-3; GEN-4; GEN-5	106.511	Version No.2/Sept 4, 2000	Records of operational hours limited to 100 hrs/yr and actual emissions not to exceed the limits in PBR 106.4(a)

Form OP-REQ2
Negative Applicable/Superseded Requirement Determinations
Texas Commission on Environmental Quality

Date	Permit No.	Regulated Entity No.
6/6/2025	4119	RN109161745

Unit AI	Revision No.	Unit/Group/Process ID No.	Unit/Group/Process Applicable Form	Potentially Applicable Regulatory Name	Negative Applicability/Superseded Requirement Citation	Negative Applicability/Superseded Requirement Reason
		GRP-ELECOMPRESS	OP-REQ2	40 CFR 60 NSPS JJJJ	40 CFR 60.4230(a)	These units are electric compressor engines.
		GRP-ELECOMPRESS	OP-REQ2	40 CFR 60 NSPS JJJJ	40 CFR 60.4230(a)	These units are electric compressor engines
		HMO-4 HMO-5 HMO-781	OP-REQ2	40 CFR 60 NSPS Dc	40 CFR 60.40c(a)	These units are rated less than 10 MMBTUH

Form OP-REQ2
Negative Applicable/Superseded Requirement Determinations
Texas Commission on Environmental Quality

Date	Permit No.	Regulated Entity No.
6/6/2025	4119	RN109161745

Unit AI	Revision No.	Unit/Group/Process ID No.	Unit/Group/Process Applicable Form	Potentially Applicable Regulatory Name	Negative Applicability/Superseded Requirement Citation	Negative Applicability/Superseded Requirement Reason
		GRP-PROCESS_HTR	OP-REQ2	40 CFR 60 NSPS Dc	40 CFR 60.41(c)	These units are process heaters as defined in this subpart and excluded from the requirements in this subpart.
		GRP-10K-6TPY	OP-UA3	40 CFR 60 NSPS Kb	40 CFR 60.110b(d)(4)	These tanks are less than 10,000 bbl used to store condensate prior to custody transfer.
		GRP-10K-6TPY	OP-UA3	40 CFR 60 NSPS Kb	40 CFR 60.110b(d)(4)	These tanks are less than 10,000 bbl used to store condensate prior to custody transfer.

Form OP-REQ2
Negative Applicable/Superseded Requirement Determinations
Texas Commission on Environmental Quality

Date	Permit No.	Regulated Entity No.
6/6/2025	4119	RN109161745

Unit AI	Revision No.	Unit/Group/Process ID No.	Unit/Group/Process Applicable Form	Potentially Applicable Regulatory Name	Negative Applicability/Superseded Requirement Citation	Negative Applicability/Superseded Requirement Reason
		GRP-10K-6TPY	OP-UA3	40 CFR 60 NSPS Kb	40 CFR 60.110b(d)(4)	These tanks are less than 10,000 bbl used to store condensate prior to custody transfer.
		GRP-10K-6TPY	OP-UA3	40 CFR 60 NSPS Kb	40 CFR 60.110b(d)(4)	These tanks are less than 10,000 bbl used to store produced water prior to custody transfer.
		GRP-10K-6TPY	OP-UA3	40 CFR 60 NSPS Kb	40 CFR 60.110b(d)(4)	These tanks are less than 10,000 bbl used to store slop water prior to custody transfer.

Form OP-REQ2
Negative Applicable/Superseded Requirement Determinations
Texas Commission on Environmental Quality

Date	Permit No.	Regulated Entity No.
6/6/2025	4119	RN109161745

Unit AI	Revision No.	Unit/Group/Process ID No.	Unit/Group/Process Applicable Form	Potentially Applicable Regulatory Name	Negative Applicability/Superseded Requirement Citation	Negative Applicability/Superseded Requirement Reason
		BULLET TANKS	OP-REQ2	40 CFR 60 NSPS Kb	40 CFR 60.110b(d)(2)	This subpart does not apply to pressurized tanks designed to operated in excess of 204.9kPa and without emission to the atmosphere.
		LOAD2-CNDNSATE	OP-REQ2	40 CFR 64	40 CFR 64.2(a)(3)	The source does not satisfy all the applicability criteria as the pre-control device emissions are less than required for a source to be major.

Form OP-REQ2
Negative Applicable/Superseded Requirement Determinations
Texas Commission on Environmental Quality

Date	Permit No.	Regulated Entity No.
6/6/2025	4119	RN109161745

Unit AI	Revision No.	Unit/Group/Process ID No.	Unit/Group/Process Applicable Form	Potentially Applicable Regulatory Name	Negative Applicability/Superseded Requirement Citation	Negative Applicability/Superseded Requirement Reason
		LOAD-CONDENSATE LOAD-PRODUCED WATER/SLOP LOAD2-PRODUCED WATER/SLOP	OP-REQ2	30 TAC Chapter 115, Loading and Unloading of VOC	115.212	This facility is not located in a covered attainment county or in a non-attainment county.
		LOAD2-CNDNSATE	OP-UA1	30 TAC Chapter 115, Loading and Unloading of VOC	115.212	This facility is not located in a covered attainment county or in a non-attainment county.
		AMINE-1	OP-UA10	40 CFR 64	40 CFR 64.2(a)(3)	The source does not satisfy all the applicability criteria as the pre-control device emissions are less than required for a source to be major.

Form OP-REQ2
Negative Applicable/Superseded Requirement Determinations
Texas Commission on Environmental Quality

Date	Permit No.	Regulated Entity No.
6/6/2025	4119	RN109161745

Unit AI	Revision No.	Unit/Group/Process ID No.	Unit/Group/Process Applicable Form	Potentially Applicable Regulatory Name	Negative Applicability/Superseded Requirement Citation	Negative Applicability/Superseded Requirement Reason
		GRP-METHANOL	OP-UA3	40 CFR 60 NSPS OOOOa	40 CFR 60.5430a(e)	These tanks are used to store VOC other than crude, condensate and/or produced water and thus are not considered storage vessels as defined under 40 CFR 60.5430a
		GRP-METHANOL	OP-UA3	40 CFR 60 NSPS Kb	40 CFR 60.110b(a)	These tanks have a design capacity of less than 75 cubic meters used to store VOC and are not affected sources.
		FL-1 FL-2 FL-3	OP-UA7	40 CFR 60 NSPS A	40 CFR 60.18(a)(1)	These flares are not affected sources as they do not control any NSPS affected sources present at the facility location.
		FL-1 FL-2 FL-3	OP-UA12	40 CFR 60 NSPS OOOOa	40 CFR 60.5365a(f)	These flares are not affected sources under this subpart as they do not control any NSPS affected sources present at the facility location.

Form OP-REQ2
Negative Applicable/Superseded Requirement Determinations
Texas Commission on Environmental Quality

Date	Permit No.	Regulated Entity No.
6/6/2025	4119	RN109161745

Unit AI	Revision No.	Unit/Group/Process ID No.	Unit/Group/Process Applicable Form	Potentially Applicable Regulatory Name	Negative Applicability/Superseded Requirement Citation	Negative Applicability/Superseded Requirement Reason
		FL-1 FL-2 FL-3	OP-UA12	40 CFR 60 NSPS OOOOb	40 CFR 60.5365b(f)	These flares are not affected sources as they do not control any affected sources under this subpart.
		GRP-10K-6TPY	OP-UA3	40 CFR 60 NSPS OOOOb	40 CFR 60.5365b(e)	These tanks have not been modified or reconstructed after November 15, 2021, and therefore are not affected sources.
		GRP-10K-6TPY	OP-REQ2	40 CFR 60 NSPS OOOOb	40 CFR 60.5365b(e)	These tanks have not been modified or reconstructed after November 15, 2021, and therefore are not affected sources.
		GRP-10K-6TPY	OP-REQ2	40 CFR 60 NSPS OOOOb	40 CFR 60.5365b(e)	These tanks have not been modified or reconstructed after November 15, 2021, and therefore are not affected sources.

Form OP-REQ2
Negative Applicable/Superseded Requirement Determinations
Texas Commission on Environmental Quality

Date	Permit No.	Regulated Entity No.
6/6/2025	4119	RN109161745

Unit AI	Revision No.	Unit/Group/Process ID No.	Unit/Group/Process Applicable Form	Potentially Applicable Regulatory Name	Negative Applicability/Superseded Requirement Citation	Negative Applicability/Superseded Requirement Reason
		GRP-10K-6TPY	OP-UA3	40 CFR 60 NSPS OOOOb	40 CFR 60.5365b(e)	These tanks have not been modified or reconstructed after November 15, 2021, and therefore are not affected sources.
		GRP-10K-6TPY	OP-UA3	40 CFR 60 NSPS OOOOb	40 CFR 60.5365b(e)	These tanks have not been modified or reconstructed after November 15, 2021, and therefore are not affected sources.
		GRP-METHANOL	OP-UA3	40 CFR 60 NSPS OOOOb	40 CFR 60.5365b(e)	These tanks are used to store VOC other than crude, condensate and/or produced water and thus are not considered storage vessels as defined under 40 CFR 60.5430b

Form OP-REQ2
Negative Applicable/Superseded Requirement Determinations
Texas Commission on Environmental Quality

Date	Permit No.	Regulated Entity No.
6/6/2025	4119	RN109161745

Unit AI	Revision No.	Unit/Group/Process ID No.	Unit/Group/Process Applicable Form	Potentially Applicable Regulatory Name	Negative Applicability/Superseded Requirement Citation	Negative Applicability/Superseded Requirement Reason
		GRP-COMP_OOOOA	OP-UA2	40 CFR 60 NSPS OOOOb	40 CFR 60.5365b(c)	These compressor sources have not been modified or reconstructed after November 15, 2021, and therefore are not affected sources.
		FUG-1	OP-UA12	40 CFR 60 NSPS OOOOb	40 CFR 60.5365b(d)	The existing process controllers covered under the category fugitives for equipment leaks are not affected sources under this subpart and no new natural gas process controllers have been added to the site since November 15,2021. Therefore, this is not an affected source under this subpart.

Form OP-REQ2
Negative Applicable/Superseded Requirement Determinations
Texas Commission on Environmental Quality

Date	Permit No.	Regulated Entity No.
6/6/2025	4119	RN109161745

Unit AI	Revision No.	Unit/Group/Process ID No.	Unit/Group/Process Applicable Form	Potentially Applicable Regulatory Name	Negative Applicability/Superseded Requirement Citation	Negative Applicability/Superseded Requirement Reason
		FUG-1	OP-UA12	40 CFR 60 NSPS OOOOb	40 CFR 60.5365b(h)	The existing pneumatic pumps covered under fugitives for equipment leaks are not affected sources under this subpart and no new natural gas process pumps have been added to the site since November 15,2021. Therefore, this is not an affected source under this subpart.
		AMINE-1 AMINE-2 AMINE-3	OP-UA10	40 CFR 60 NSPS OOOOb	40 CFR 60.5365b(g)	These amine units have a design capacity of less than 2LTD and have not been modified or reconstructed since November 15, 2021. Therefore, these amine units are not affected sources under this subpart.
		FUG-1	OP-UA12	40 CFR 60 NSPS OOOOb	40 CFR 60.5365b(f)(1)	There are no process unit equipment that were added or replaced after November 15, 2021. Therefore, this site is not an affected source.
		FUG-1	OP-UA12	40 CFR 60 NSPS OOOOb	40 CFR 60.5365b(f)(1)	This is not an affected source for fugitive due to the applicability date in this Subpart as no modification or reconstruction has occurred since November 15, 2021.

**Texas Commission on Environmental Quality
Federal Operating Permit Program
Individual Unit Summary for Revisions
Form OP-SUMR**

[Table 1](#)

Date	Permit No.	Regulated Entity No.
6/6/2025	4119	RN109161745

Unit/Process AI	Unit/Process Revision No.	Unit/Process ID No.	Unit/Process Applicable Form	Unit/Process Name/ Description	Unit/Process CAM	Preconstruction Authorizations 30 TAC Chapter 116/ 30 TAC Chapter 106	Preconstruction Authorizations Title I
D	1	CR-2209	OP-UA2	Residue Compressor -9		140834	
D	2	CR-2210	OP-UA2	Residue Compressor-10		140834	
D	3	CR-2211	OP-UA2	Residue Compressor 11		140834	
D	4	LOAD3-CNDNSATE	OP-UA1	Condensate Loading III	Y	140834	
A	5	TO-1A	OP-UA1	Plant 1 Thermal Oxidizer		140834	
A	6	TO-2	OP-UA1	Plant 1 Thermal Oxidizer		140834	
A	7	TO-3	OP-UA1	Plant 1 Thermal Oxidizer		140834	

**Fugitive Emission Unit Attributes
Form OP-UA12 (Page 170)**

Federal Operating Permit Program

Table 19b: Title 40 Code of Federal Regulations Part 60 (40 CFR Part 60)

Subpart OOOOa: Standards of Performance for Crude Oil and Natural Gas Facilities for which Construction, Modification or Reconstruction

Commenced After September 18, 2015

Texas Commission on Environmental Quality

Date	Permit No.	Regulated Entity No.
6/4/2025	4119	RN109161745

Unit ID No.	SOP/GOP Index No.	Construction/Modification Date	Reciprocating Compressor	AMEL	Bypass Device
GRP-COMP_OOOOA	604Oa-RCP1COMP	15+	RC26K-	NO	
GRP-COMP_OOOOA	604Oa-RCP2COMP	15+	RC26K-	NO	
GRP-COMP_OOOOA	604Oa-VRUCOMP	15+	RC26K-	NO	
GRP-ELECOMPRESS	604Oa-ECOMP				
GRP-ELECOMPRESS	604Oa-EVRU	15+	RC26K-	NO	

**Fugitive Emission Unit Attributes
Form OP-UA12 (Page 184)
Federal Operating Permit Program**

**Table 19p: Title 40 Code of Federal Regulations Part 60 (40 CFR Part 60)
Subpart OOOOa: Standards of Performance for Crude Oil and Natural Gas Facilities for which Construction, Modification or Reconstruction
Commenced After September 18, 2015
Texas Commission on Environmental Quality**

Date	Permit No.	Regulated Entity No.
6/4/2025	4119	RN109161745

Unit ID. No.	SOP/GOP Index No.	Title 40 CFR Part 60, Subpart OOOOa Fugitive Unit Components (continued)
		Title 40 CFR Part 60, Subpart OOOOa Fugitive Unit Description
GRP-COMP_OOOOA	604Oa-RCP1COMP	Reciprocating compressors units at Plant 1
GRP-COMP_OOOOA	604Oa-RCP2COMP	Reciprocating compressors units at Plant 2
GRP-COMP_OOOOA	604Oa-VRUCOMP	Reciprocating compressors units less than 1000 hp
GRP-ELECOMPRESS	604Oa-ECOMP	Electric compressor units
GRP-ELECOMPRESS	604Oa-EVRUCOMP	Electric compressor units
FUG-1	604Oa-PNEUCONTR	Sitewide pneumatic controllers at a Plant 1, 2 and 3
FUG-1	604Oa-PNEUPUMP	Sitewide pneumatic pumps at Plant 1, 2 and 3
FUG-1	604Oa-PUMPLL	Sitewide Pumps in light liquid service at Plant 1, 2 and 3
FUG-1	604Oa-PRD	Sitewide Pressure relief devices at Plant 1, 2 and 3
FUG-1	604Oa-VALVEOEL	Sitewide Open ended line valves at Plant 1, 2 and 3

Emily L. Knodell
 Permit Reviewer
 TCEQ – APD – OP Section (Title V)
 (512) 239-3107

How are we doing? Fill out our online customer satisfaction survey at www.tceq.texas.gov/customersurvey

From: Arthi Reddy <Arthi.Reddy@c-ka.com>
 Sent: Friday, June 6, 2025 8:59 AM
 To: Emily Knodell <Emily.Knodell@tceq.texas.gov>
 Cc: Gary Mann <mann@brazosmidstream.com>; Gordon Moore <gordon.moore@c-ka.com>
 Subject: RE: Technical Review -- FOP O4119/Project 37272, Brazos Midstream Operating, LLC/Comanche Plant

Hi Emily:

Thanks, for your email. I called you yesterday but its all good now. Please see attached my responses in blue and all the revised forms for your review. I have attached the revised forms in PDF as separate attachments for convenience. Please let me know if you need any additional information and/or have any questions.

Thanks
 Arthi

From: Emily Knodell <Emily.Knodell@tceq.texas.gov>
 Sent: Wednesday, June 4, 2025 11:25 AM
 To: Arthi Reddy <Arthi.Reddy@c-ka.com>
 Cc: Gary Mann <mann@brazosmidstream.com>; Gordon Moore <gordon.moore@c-ka.com>
 Subject: RE: Technical Review -- FOP O4119/Project 37272, Brazos Midstream Operating, LLC/Comanche Plant

Good morning all,

During technical review, the following items were found. Please resolve the items below by **06/11/2025**.

- Form OP-UA1 (Page 1), OP-2, OP-SUMR:** The application Form OP-UA1 lists several Unit IDs (TO-1A, TO-2, TO-3) that do not appear to be existing units in our database. Please go ahead and add them to Form OP-2 and OP-SUMR which will give me the identifying information needed for the unit (name, applicable form, preconstruction authorization, etc.) so that I can add them to the database. They are already referenced on your OP-UA1, but you can send a revised OP-UA1 which has a SOP Index No. for the units. Please submit all three revised forms.
 Please see revised forms OP-2, OP-SUMR and OP-UA1 to add the existing units TO-1A, TO-2 and TO-3 to the permit tables.
- Form OP-UA12 (Page 170):** Could you please also send Form OP-UA12 (Page 170)? I see Form OP-UA12 was attached with only page 184. This was from item #3 in my 05/21 email. Please see attached revised Pages 170 and 184 for Form OP-UA12 as per your email request on 5/21/2025.
- Form OP-REQ2, OP-SUMR, OP-2:** Please revise this form to use the Group ID instead of the individual Unit IDs to avoid confusion when this project passes through management review. For example, use GRP-METHANOL instead of listing TK-MET1, TK-MET2, TK-MET3, etc. Also, I noticed a few Groups IDs listed in the OP-REQ2 that are not in our database (GRP-PROCESS CONTROLLERS, GRP-PNEUMATIC PUMPS, GRP-PROCESS-EQUP). Are these new groups you want to add? If these are new groups being added, please add them to Form OP-SUMR (Table 2) and OP-2 (Table 2). I have included screenshots below to visually describe this item.
 The forms OP-REQ2, OP-SUMR and OP-2 have been revised accordingly and included with this email for grouping of compressors, process heaters and tanks. Regarding the GRP-CONTROLLERS, GRP-PNEUMATIC PUMPS; and GRP-PROCESS-EQUP are not new emissions units or points but are same as fugitive emission source covered under Emission Point ID FUG-1. I have changed the IDs to FUG-1 to avoid confusion.

Form OP-REQ2
 Negative Applicable/Superseded Requirement Determinations
 Texas Commission on Environmental Quality

Date	Permit No.	Regulated Entity No.
9/03/2024	4119	RN109161745

Unit ID	Revision No.	Unit/Group/Process ID No.	Unit/Group/Process Applicable Form	Potentially Applicable Regulatory Name	Negative Applicability/Superseded Requirement Citation	Negative Applicability/Superseded Requirement Reason
		ECR-2212 ECR-2213 ECR-2214 ECR-2215	OP-REQ2 GRP-ELECOMPRESS	40 CFR 60 NSPS JJJJ	40 CFR 60.4230(a)	These units are electric compressor engines.
		E-VRUCOMP1 E-VRUCOMP2 E-VRUCOMP3 E-VRUCOMP4	OP-REQ2 GRP-ELECOMPRESS	40 CFR 60 NSPS JJJJ	40 CFR 60.4230(a)	These units are electric compressor engines.
		HMO-4 HMO-5 HMO-781	OP-REQ2	40 CFR 60 NSPS Dc	40 CFR 60.40(a)	These units are rated less than 10 MMBTU/H

Form OP-REQ2
 Negative Applicable/Superseded Requirement Determinations
 Texas Commission on Environmental Quality

Date	Permit No.	Regulated Entity No.
9/03/2024	4119	RN109161745

Unit ID	Revision No.	Unit/Group/Process ID No.	Unit/Group/Process Applicable Form	Potentially Applicable Regulatory Name	Negative Applicability/Superseded Requirement Citation	Negative Applicability/Superseded Requirement Reason
		H-741 AMINE-HTR1 STB-HTR1 STB-HTR2 TIG-HTR1 TIG-HTR2 AMINE-HTR2 AMINE-HTR3 HTR-3	OP-REQ2 GRP-PROCESS_HTR	40 CFR 60 NSPS Dc	40 CFR 60.41(c)	These units are process heaters as defined in this subpart and excluded from the requirements in this subpart.
		TK-800 TK-801 TK-802 TK-803	OP-UA3 GRP-10K-6TPY	40 CFR 60 NSPS Kb	40 CFR 60.1108(d)(4)	These tanks are less than 10,000 bbl used to store condensate prior to custody transfer.
		TK-10730 TK-10731 TK-10732 TK-10733 TK-10734 TK-10735 TK-10736	OP-UA3 GRP-10K-6TPY	40 CFR 60 NSPS Kb	40 CFR 60.1108(d)(4)	These tanks are less than 10,000 bbl used to store condensate prior to custody transfer.

Form OP-REQ2
Negative Applicable/Superseded Requirement Determinations
Texas Commission on Environmental Quality

Date		Permit No.		Regulated Entity No.		
9/03/2024		4119		RN109161745		
Unit ID	Revision No.	Unit/Group/Process ID No.	Unit/Group/Process Applicable Form	Potentially Applicable Regulatory Name	Negative Applicability/Superseded Requirement Citation	Negative Applicability/Superseded Requirement Reason
		TK-10740 TK-10741 TK-10742 TK-10743 TK-10744 TK-10745 TK-10746	OP-UA3 GRP-10K-6TPY	40 CFR 60 NSPS Kb	40 CFR 60.110b(d)(4)	These tanks are less than 10,000 bbl used to store condensate prior to custody transfer.
		TK-804 TK-10719 TK-10720	OP-UA3 GRP-10K-6TPY	40 CFR 60 NSPS Kb	40 CFR 60.110b(d)(4)	These tanks are less than 10,000 bbl used to store produced water prior to custody transfer.
		TK-100 TK-2245 TK-10717 TK-10718 TK-20717 TK-20718 TK-20705	OP-UA3 GRP-10K-6TPY	40 CFR 60 NSPS Kb	40 CFR 60.110b(d)(4)	These tanks are less than 10,000 bbl used to store slop water prior to custody transfer.

Form OP-REQ2
Negative Applicable/Superseded Requirement Determinations
Texas Commission on Environmental Quality

Date		Permit No.		Regulated Entity No.		
9/03/2024		4119		RN109161745		
Unit ID	Revision No.	Unit/Group/Process ID No.	Unit/Group/Process Applicable Form	Potentially Applicable Regulatory Name	Negative Applicability/Superseded Requirement Citation	Negative Applicability/Superseded Requirement Reason
		BULLET TANKS	OP-REQ2	40 CFR 60 NSPS Kb	40 CFR 60.110b(d)(2)	This subpart does not apply to pressurized tanks designed to operated in excess of 204.9kPa and without emission to the atmosphere.
		LOAD-CONDENSATE LOAD2-CONDENSATE	OP-REQ2	40 CFR 64	40 CFR 64.2(a)(3)	The source does not satisfy all the applicability criteria as the pre-control device emissions are less than required for a source to be major.

Negative Applicable/Superseded Requirement Determinations
Texas Commission on Environmental Quality

Date		Permit No.		Regulated Entity No.		
9/03/2024		4119		RN109161745		
Unit ID	Revision No.	Unit/Group/Process ID No.	Unit/Group/Process Applicable Form	Potentially Applicable Regulatory Name	Negative Applicability/Superseded Requirement Citation	Negative Applicability/Superseded Requirement Reason
		TK-MET1 TK-MET2 TK-MET3 TK-MET4 TK-MET5 TK-MET6 GRP-METHANOL	OP-UA3	40 CFR 60 NSPS OOOOa	40 CFR 60.543b(e)	These tanks are used to store VOC other than crude, condensate and/or produced water and that are not considered storage vessels as defined under 40 CFR 60.543a
		TK-MET1 TK-MET2 TK-MET3 TK-MET4 TK-MET5 TK-MET6 GRP-METHANOL	OP-UA3	40 CFR 60 NSPS Kb	40 CFR 60.110b(a)	These tanks have a design capacity of less than 75 cubic meters used to store VOC and are not affected sources.
		FL-1 FL-2 FL-3	OP-UA7	40 CFR 60 NSPS A	40 CFR 60.18(a)(1)	These flares are not affected sources as they do not control any NSPS affected sources present at the facility location.
		FL-1 FL-2 FL-3	OP-UA12	40 CFR 60 NSPS OOOOa	40 CFR 60.5365a(f)	These flares are not affected sources under this subpart as they do not control any NSPS affected sources present at the facility location.

Negative Applicable/Superseded Requirement Determinations
Texas Commission on Environmental Quality

Date		Permit No.		Regulated Entity No.		
9/03/2024		4119		RN109161745		
Unit ID	Revision No.	Unit/Group/Process ID No.	Unit/Group/Process Applicable Form	Potentially Applicable Regulatory Name	Negative Applicability/Superseded Requirement Citation	Negative Applicability/Superseded Requirement Reason
		FL-1 FL-2 FL-3	OP-UA12	40 CFR 60 NSPS OOOOb	40 CFR 60.5365b(f)	These flares are not affected sources as they do not control any affected sources under this subpart.
		TK-800 TK-801 TK-802 TK-803 GRP-10K-6TPY	OP-UA3	40 CFR 60 NSPS OOOOb	40 CFR 60.5365b(e)	These tanks have not been modified or reconstructed after November 15, 2021, and therefore are not affected sources.
		TK-10730 TK-10731 TK-10732 TK-10733 TK-10734 TK-10735 TK-10736 GRP-10K-6TPY	OP-REQ2	40 CFR 60 NSPS OOOOb	40 CFR 60.5365b(e)	These tanks have not been modified or reconstructed after November 15, 2021, and therefore are not affected sources.
		TK-804 TK-10719 TK-10720 GRP-10K-6TPY	OP-REQ2	40 CFR 60 NSPS OOOOb	40 CFR 60.5365b(e)	These tanks have not been modified or reconstructed after November 15, 2021, and therefore are not affected sources.

Form OP-REQ2
Negative Applicable/Superseded Requirement Determinations
Texas Commission on Environmental Quality

Date		Permit No.		Regulated Entity No.		
9/03/2024		4119		RN109161745		
Unit AI	Revision No.	Unit/Group/Process ID No.	Unit/Group/Process Applicable Form	Potentially Applicable Regulatory Name	Negative Applicability/Superseded Requirement Citation	Negative Applicability/Superseded Requirement Reason
		TK-10740 TK-10741 TK-10742 TK-10743 TK-10744 TK-10745 TK-10746	OP-4/A3 GRF-10K-6TPY	40 CFR 60 NSPS 0000b	40 CFR 60.5365b(c)	These tanks have not been modified or reconstructed after November 15, 2021, and therefore are not affected sources.
		TK-2245 TK-10717 TK-10718 TK-20717 TK-20718 TK-20705	OP-4/A3 GRF-10K-6TPY	40 CFR 60 NSPS 0000b	40 CFR 60.5365b(c)	These tanks have not been modified or reconstructed after November 15, 2021, and therefore are not affected sources.
		TK-MET1 TK-MET2 TK-MET3 TK-MET4 TK-MET5 TK-ME16	OP-4/A3 GRP-METHANOL	40 CFR 60 NSPS 0000b	40 CFR 60.5365b(c)	These tanks are used to store VOC other than crude, condensate and/or produced water and thus are not considered storage vessels as defined under 40 CFR 60.5430b

Form OP-REQ2
Negative Applicable/Superseded Requirement Determinations
Texas Commission on Environmental Quality

Date		Permit No.		Regulated Entity No.		
9/03/2024		4119		RN109161745		
Unit AI	Revision No.	Unit/Group/Process ID No.	Unit/Group/Process Applicable Form	Potentially Applicable Regulatory Name	Negative Applicability/Superseded Requirement Citation	Negative Applicability/Superseded Requirement Reason
		CR-2201 CR-2202 CR-2203 CR-2204 CR-2205 CR-2206 CR-2207 CR-2208 VCOMP-1 VCOMP-2	OP-4/A2 GRF-COMP_0000A	40 CFR 60 NSPS 0000b	40 CFR 60.5365b(c)	These compressor sources have not been modified or reconstructed after November 15, 2021, and therefore are not affected sources.
		GRD-PROCESS CONTROLLERS Is this a new group ID?	OP-4/A12	40 CFR 60 NSPS 0000b	40 CFR 60.5365b(d)	The existing process controllers are not affected sources under this subpart and no new natural gas process controllers have been added to the site since November 15, 2021. Therefore, this is not an affected source under this subpart.

Texas Commission on Environmental Quality

Date		Permit No.		Regulated Entity No.		
9/03/2024		4119		RN109161745		
Unit AI	Revision No.	Unit/Group/Process ID No.	Unit/Group/Process Applicable Form	Potentially Applicable Regulatory Name	Negative Applicability/Superseded Requirement Citation	Negative Applicability/Superseded Requirement Reason
		GRP-PNEUMATIC PUMPS Is this a new group ID?	OP-4/A12	40 CFR 60 NSPS 0000b	40 CFR 60.5365b(h)	The existing pumps are not affected sources under this subpart and no new natural gas process pumps have been added to the site since November 15, 2021. Therefore, this is not an affected source under this subpart.
		AMINE-1 AMINE-2 AMINE-3	OP-4/A10	40 CFR 60 NSPS 0000b	40 CFR 60.5365b(g)	These amine units have a design capacity of less than 2LTD and have not been modified or reconstructed since November 15, 2021. Therefore, these amine units are not affected sources under this subpart.
		GRP-PROCESS-EQUIP Is this a new group ID?	OP-4/A12	40 CFR 60 NSPS 0000b	40 CFR 60.5365b(i)(1)	There are no process unit equipment that were added or replaced after November 15, 2021. Therefore, this site is not an affected source.
		FLUG-1	OP-4/A12	40 CFR 60 NSPS 0000b	40 CFR 60.5365b(i)(1)	This is not an affected source for fugitive due to the applicability date in this Subpart as no modification or reconstruction has occurred since November 15, 2021.

4. **Form OP-PBRSUP:** In the OP-PBRSUP dated 04/08/2025, only a Table B was submitted. The OP-PBRSUP instructions state that Emission units authorized under the following PBRs and any corresponding historical (pre-March 1997) SEs are required to be listed in sections A, B, and D. Since the PBRs listed on your Form OP-REQ1 (Page 89) are on this list (see screenshot below), they must be added to sections A, B, and D. Please submit the OP-PBRSUP in full, including tables A, B, C, and D with matching dates on each table. (No table should be blank, but "none" or "NA" can be used on a table as appropriate, this allows the public to know a table was not inadvertently left out and that the site is not using any insignificant PBRs). Also, you can list the emission unit as "sitewide" if there is no specific emission unit with that authorization. [The revised OP-PBRSUP form is attached.](#)

OP-PBR SUP Instructions

PBR No.	Name or Subject	PBR No.	Name or Subject
106.223	Sawmills	106.417	Ethylene Oxide Sterilizers
106.224	Aerospace	106.418	Printing Presses
106.225	Semiconductor	106.419	Photographic Process Equipment
106.226	Coating Manufacturing	106.433	Surface Coat
106.227	Soldering, Brazing, Welding	106.434	Powder Coating Facility
106.231	Wood Products	106.435	Classic or Antique Auto Restoration Facility
106.245	Ethyl Alcohol Facilities	106.436	Auto Body Refinishing
106.261	Facility; Emission Limits	106.452	Dry Abrasive Cleaning
106.262	Facility; Emission/Distance	106.454	Degreasing
106.263	Repairs and Maintenance	106.472	Organic/Inorganic Liquid Loading and Unloading
106.264	Replacements of Facilities	106.473	Organic Liquid Loading and Unloading
106.265	Hand-Held/Manually Operated Machines	106.474	Hydrochloric Acid Storage
106.281	Feed Milling	106.475	Pressure Tank or Vent to Firebox
106.283	Grain Handling	106.476	Pressure Tank or Vent to Control
106.311	Crucible or Pot Furnace	106.477	Anhydrous NH3 Storage
106.314	Shell Core and Mold Machines	106.478	Storage Tank and Change Service
106.315	Sand or Investment Molds	106.491	Dual Chamber Incinerators
106.320	Miscellaneous Metallic Treatment	106.492	Flares
106.321	Metal Melting and Holding Furnace	106.493	Direct Flame Incinerators
106.322	Furnace to Reclaim Aluminum or Copper	106.494	Pathological Waste Incinerators
106.332	Chlorine Repackaging	106.495	Heat Cleaning Devices
106.351	Salt Water Disposal	106.496	Air Curtain Incinerators
106.352	Oil and Gas Production	106.511	Portable and Emergency Engines and Turbines

OP-PBR SUP Instructions

PBR No.	Name or Subject	PBR No.	Name or Subject
106.353	Temporary Oil and Gas Facilities	106.512	Stationary Engines and Turbines
106.354	Iron Sponge Gas-Treating Unit	106.513	Natural Gas-Fired Combined Heat and Power Units
106.355	Pipeline Metering, Purging, and Maintenance	106.532	Water/Wastewater Treatment
106.359	Planned Maintenance, Startup, and Shutdown (MSS) at Oil and Gas Handling and Production Facilities	106.533	Water and Soil Remediation
106.371	Cooling Water Units	106.534	Municipal Solid Waste Landfills and Transfer Stations

- A. Registered Permits by Rule (30 TAC Chapter 106) for the Application Area
- This section provides all PBR authorized emission units for the application area that require registration with the TCEQ.
- Unit ID No.:**
Enter the identification number (ID No.) for the emission unit authorized by the registered PBR (maximum 10 characters). If listed on Form OP-SUM (Individual Unit Summary), the ID No. should match.
- Registration No.:**
Enter the registration number provided by TCEQ upon authorization.
- PBR No.:**
For PBRs (Standard Exemption) authorized before March 14, 1997, enter the selected PBR (Standard Exemption) number, in the space provided (XXX). For PBRs authorized on or after March 14, 1997, enter the selected PBR section number, in the space provided (106.XXX).
- Registration Date:**
Enter the date (MM/DD/YYYY) the authorization was issued to the site. This is the date of the PBR authorization letter.

Please let me know if you have any questions. Thank you!

Best Regards,

Emily L. Knodell
Permit Reviewer
TCEQ – APD – OP Section (Title V)
(512) 239-3107

 How are we doing? Fill out our online customer satisfaction survey at www.tceq.texas.gov/customersurvey

From: Emily Knodell
Sent: Tuesday, June 3, 2025 9:47 AM
To: Arthi Reddy <Arthi.Reddy@c-ka.com>
Cc: Gary Mann <mann@brazozmidstream.com>; Gordon Moore <gordon.moore@c-ka.com>
Subject: RE: Technical Review -- FOP 04119/Project 37272, Brazos Midstream Operating, LLC/Comanche Plant

Good morning Arthi,

Thank you for sending the updated forms. Could you please also send Form OP-UA12 (Page 170)? I see Form OP-UA12 was attached with only page 184. This is from item #3 below.

Thank you,

Emily L. Knodell
Permit Reviewer
TCEQ – APD – OP Section (Title V)
(512) 239-3107

 How are we doing? Fill out our online customer satisfaction survey at www.tceq.texas.gov/customersurvey

From: Arthi Reddy <Arthi.Reddy@c-ka.com>
Sent: Thursday, May 22, 2025 1:53 PM
To: Emily Knodell <Emily.Knodell@tceq.texas.gov>
Cc: Gary Mann <mann@brazozmidstream.com>; Gordon Moore <gordon.moore@c-ka.com>
Subject: RE: Technical Review -- FOP 04119/Project 37272, Brazos Midstream Operating, LLC/Comanche Plant

Hi Emily,

Please see my response below in blue and supporting attachments. Please let me know if you have any questions or need anything else. Thank you for your time in this matter.

Arthi

Form OP-REQ1: Page 88	
XII. NSR Authorizations (Attach additional sheets if necessary for sections E-J)	
◆ I. Permits by Rule (30 TAC Chapter 106) for the Application Area	
<i>A list of selected Permits by Rule (previously referred to as standard exemptions) that are required to be listed in the FOP application is available in the instructions.</i>	
PBR No.: 106.359	Version No./Date: Version 1 /Sept 10, 2013
PBR No.: 106.472	Version No./Date: Version 2/Sept 4, 2000
PBR No.: 106.473	Version No./Date: Version 2/Sept 4, 2000
PBR No.: 106.511	Version No./Date: Version 2/Sept 4, 2000
PBR No.:	Version No./Date:
PBR No.:	Version No./Date:
PBR No.:	Version No./Date:

Storage Tank/Vessel Attributes
Form OP-UA3 (Page 3)
Federal Operating Permit Program
Table 3: Title 40 Code of Federal Regulations Part 60 (40 CFR Part 60)
Subpart Kb: Standards of Performance for Volatile Organic Liquid Storage Vessels
(Including Petroleum Liquid Storage Vessels)
Texas Commission on Environmental Quality

Date	Permit No.	Regulated Entity No.
5/22/2025	4119	RN109161745

Unit ID No.	SOP/GOP Index No.	Product Stored	Storage Capacity	WW Tank Control	Maximum TVP	Storage Vessel Description	AMEL ID No.	Guidepole	Reid Vapor Pressure	Control Device ID No.
GRP-METHANOL	60Kb-MET	VOL	10K-							

**Storage Tank/Vessel Attributes
Form OP-UA3 (Page 64)
Federal Operating Permit Program
Table 24a: Title 40 Code of Federal Regulations Part 60 (40 CFR Part 60)
Subpart OOOOa: Standards of Performance for Crude Oil and Natural Gas Facilities for which Construction, Modification or Reconstruction
Commenced After September 18, 2015
Texas Commission on Environmental Quality**

Date	Permit No.	Regulated Entity No.
5/22/2025	4119	RN109161745

Unit ID No.	SOP/GOP Index No.	Construction/Modification Date	Subject to Another Regulation	PTE	Compliance Option	Control Option	Control Device ID No.
GRP-10K-6TPY	604Oa-10K	15+	NO	6-			

**Fugitive Emission Unit Attributes
Form OP-UA12 (Page 184)
Federal Operating Permit Program**

**Table 19p: Title 40 Code of Federal Regulations Part 60 (40 CFR Part 60)
Subpart OOOOa: Standards of Performance for Crude Oil and Natural Gas Facilities for which Construction, Modification or Reconstruction
Commenced After September 18, 2015
Texas Commission on Environmental Quality**

Date	Permit No.	Regulated Entity No.
5/22/2025	4119	RN109161745

Unit ID. No.	SOP/GOP Index No.	Title 40 CFR Part 60, Subpart OOOOa Fugitive Unit Components (continued)
		Title 40 CFR Part 60, Subpart OOOOa Fugitive Unit Description
GRP-COMP_OOOOA	604Oa-RCP1COMP	Reciprocating compressors units at Plant 1
GRP-COMP_OOOOA	604Oa-RCP2COMP	Reciprocating compressors units at Plant 2
VCOMP-1; VCOMP-2	604Oa-VRUCOMP	Reciprocating compressors units less than 1000 hp
GRP-ELECOMPRESS	604Oa-ECOMP	Electric compressor units
GRP-ELECOMPRESS	604Oa-EVRUCOMP	Electric compressor units
FUG-1	604Oa-PNEUCONTR	Sitewide pneumatic controllers at a Plant 1, 2 and 3
FUG-1	604Oa-PNEUPUMP	Sitewide pneumatic pumps at Plant 1, 2 and 3
FUG-1	604Oa-PUMPLL	Sitewide Pumps in light liquid service at Plant 1, 2 and 3
FUG-1	604Oa-PRD	Sitewide Pressure relief devices at Plant 1, 2 and 3
FUG-1	604Oa-VALVEOEL	Sitewide Open ended line valves at Plant 1, 2 and 3

**Fugitive Emission Unit Attributes
Form OP-UA12 (Page 184)
Federal Operating Permit Program**

**Table 19p: Title 40 Code of Federal Regulations Part 60 (40 CFR Part 60)
Subpart OOOOa: Standards of Performance for Crude Oil and Natural Gas Facilities for which Construction, Modification or Reconstruction
Commenced After September 18, 2015
Texas Commission on Environmental Quality**

Date	Permit No.	Regulated Entity No.
5/22/2025	4119	RN109161745

Unit ID. No.	SOP/GOP Index No.	Title 40 CFR Part 60, Subpart OOOOa Fugitive Unit Components (continued)
		Title 40 CFR Part 60, Subpart OOOOa Fugitive Unit Description
GRP-COMP_OOOOA	604Oa-RCP1COMP	Reciprocating compressors units at Plant 1
GRP-COMP_OOOOA	604Oa-RCP2COMP	Reciprocating compressors units at Plant 2
GRP-COMP_OOOOA	604Oa-VRUCOMP	Reciprocating compressors units less than 1000 hp
GRP-ELECOMPRESS	604Oa-ECOMP	Electric compressor units
GRP-ELECOMPRESS	604Oa-EVRUCOMP	Electric compressor units
FUG-1	604Oa-PNEUCONTR	Sitewide pneumatic controllers at a Plant 1, 2 and 3
FUG-1	604Oa-PNEUPUMP	Sitewide pneumatic pumps at Plant 1, 2 and 3
FUG-1	604Oa-PUMPLL	Sitewide Pumps in light liquid service at Plant 1, 2 and 3
FUG-1	604Oa-PRD	Sitewide Pressure relief devices at Plant 1, 2 and 3
FUG-1	604Oa-VALVEOEL	Sitewide Open ended line valves at Plant 1, 2 and 3

From: Emily Knodell <Emily.Knodell@tceq.texas.gov>
 Sent: Wednesday, May 21, 2025 1:09 PM
 To: Arthi Reddy <Arthi.Reddy@cka.com>
 Cc: Gordon Moore <gordon.moore@c-ka.com>; Gary Mann <mann@brazosmidstream.com>
 Subject: RE: Technical Review -- FOP 04119/Project 37272, Brazos Midstream Operating, LLC/Comanche Plant

Good afternoon Arthi,

Thank you for sending the requested forms. Please resolve the items below by **05/28/2025**.

- Form OP-UA1 (Page 1):** This form lists several Unit IDs (TO-1A, TO-2, TO-3) that do not appear to be existing units in our database. If these are new units, please add them to Form OP-2 and OP-SUMR which will give me the identifying information needed for the unit (name, applicable form, preconstruction authorization, etc.) so that I can add them to the database.
 These units are not new; however, they are subject to the opacity requirements listed in Special Conditions for stationary vents. Please let me know if these units need to be referenced in the OP-UA1 form.
- Form OP-UA3 (Page 3):** This form has several groups listed in our database which are listed out in the UA form as individual units. Do you want to keep them in groups or move them out of groups? In order for units to be in the same group, they must have identical unit attribute (UA) data. If the UA data is no longer identical, the units must be moved out of the groups. I have listed a description of where this occurs below.
 Please see updated forms for OP-UA3 (Page 3 and 64). The tanks are now grouped as per the current permit grouping IDs.
 - GRP-METHANOL** (consisting of Unit IDs TK-MET1, TK-MET2, TK-MET-3, TK-MET4, TK-MET5, TK-MET6). The UA form lists them as individual units on Form OP-UA3 (Page 3) with six separate index numbers. If you would like to keep all the units in the group, please send a revised OP-UA3 (Page 3) which lists the Group ID instead of the units.

STORAGE TANK VESSEL ATTRIBUTES
 Form OP-UA3 (Page 3)
 Federal Operating Permit Program
 Table 3: Title 40 Code of Federal Regulations Part 60 (40 CFR Part 60)
 Subpart Kb: Standards of Performance for Volatile Organic Liquid Storage Vessels
 (Including Petroleum Liquid Storage Vessels)
 Texas Commission on Environmental Quality

Note: these unit IDs are under GRP-METHANOL

Date		Permit No.		Regulated Entity No.	
9/03/2024		4119		RN109161745	

Unit ID No.	SOP/GOP Index No.	Product Stored	Storage Capacity	WW Tank Control	Maximum TVP	Storage Vessel Description	AMEL ID No.	Guidepole	Reid Vapor Pressure	Control Device ID No.
TK-MET1	60kb-MET1	VOL	10K-							
TK-MET2	60kb-MET2	VOL	10K-							
TK-MET3	60kb-MET3	VOL	10K-							
TK-MET4	60kb-MET4	VOL	10K-							
TK-MET5	60kb-MET5	VOL	10K-							
TK-MET6	60kb-MET6	VOL	10K-							

- GRP-10K-6TPY** (consisting of Unit IDs TK-11, TK-10717, TK-10718, TK-10719, TK-10720, TK-10730, TK-10731, TK-10732, TK-10733, TK-10734, TK-10735, TK-10736, TK-10740, TK-10741, TK-10742, TK-10743, TK-10744, TK-10745, TK-10746, TK-20705, TK-20717, TK-20718, TK-2245, TK-800, TK-801, TK-802, TK-803, and TK-804). The UA form lists them as individual units on Form OP-UA3 (Page 64,) with separate index numbers. If you would like to keep all the units in the group, please send a revised OP-UA3 (Page 364) which lists the Group ID instead of the units.
- Form OP-UA12 (Pages 170 & 184):** I noticed several groups listed in our database which are listed out in the UA form as individual units. Do you want to keep them in groups or move them out of groups? In order for units to be in the same group, they must have identical unit attribute (UA) data. If the UA data is no longer identical, the units must be moved out of the groups. I have listed a description of where this occurs below.
 Please see revised form OP-UA12 (Page # 170 and 184) with grouping IDs as per the current permit.
 - GRP-ELECOMPRESS** (consisting of unit IDs E-VRUCOM1, E-VRUCOM2, E-VRUCOM3, E-VRUCOM4, ECR-2212, ECR-2213, ECR-2214, ECR-2215). The UA form lists them as individual units on Form UA12 (Page 170 & 184) with two separate index numbers. If you would like to keep all the units in the group, please send a revised OP-UA12 (Page 170 & 184) which lists the Group ID instead of the units.
 - GRP-COMPOOOO** (consisting of Unit IDs CR-2201, CR-2202, CR-2203, CR-2204, CR-2205, CR-2206, CR-2207, CR-2208, VCOMP-1, VCOMP-2). The UA form lists them as individual units with three separate index numbers. If you would like to keep all the units in the group, please send a revised OP-UA12 (Page 170 & 184) which lists the Group ID instead of the units.

Fugitive Emission Unit Attributes
 Form OP-UA12 (Page 170)
 Federal Operating Permit Program
 Table 19b: Title 40 Code of Federal Regulations Part 60 (40 CFR Part 60)
 Subpart OOOOa: Standards of Performance for Crude Oil and Natural Gas Facilities for which Construction, Modification or Reconstruction
 Commenced After September 18, 2015
 Texas Commission on Environmental Quality

Date		Permit No.		Regulated Entity No.	
9/03/2024		4119		RN109161745	

Unit ID No.	SOP/GOP Index No.	Construction/Modification Date	Reciprocating Compressor	AMEL	Bypass Device
CR-2201 CR-2202 CR-2203 CR-2204 GRP-COMP_OOOOA	6040a-RCP1COMP	15+	RC26K-	NO	
CR-2205 CR-2206 CR-2207 CR-2208 GRP-COMP_OOOOA	6040a-RCP2COMP	15+	RC26K-	NO	
VCOMP-1 VCOMP-2 GRP-COMP_OOOOA	6040a-VRUCOMP	15+	RC26K-	NO	
ECR-2212 ECR-2213 ECR-2214 ECR-2215 GRP-ELECOMPRESS	6040a-ECOMP				
E-VRUCOM1 E-VRUCOM2 E-VRUCOM3 E-VRUCOM4 GRP-ELECOMPRESS	6040a-EVRU	15+	RC26K-	NO	

Fugitive Emission Unit Attributes
 Form OP-LA12 (Page 184)
 Federal Operating Permit Program
 Table 19p: Title 40 Code of Federal Regulations Part 60 (40 CFR Part 60)
 Subpart OOOOa: Standards of Performance for Crude Oil and Natural Gas Facilities for which Construction, Modification or Reconstruction
 Commenced After September 18, 2015
 Texas Commission on Environmental Quality

Date	Permit No.	Regulated Entity No.
9/03/2024	4119	RN109161745

Unit ID. No.	SOP/GOP Index No.	Title 40 CFR Part 60, Subpart OOOOa Fugitive Unit Components (continued) Title 40 CFR Part 60, Subpart OOOOa Fugitive Unit Description
CR-2201; CR-2202; CR-2203; CR-2204 GRP-COMP_OOOOA	6040a-RCP1COMP	Reciprocating compressors units at Plant 1
CR-2205; CR-2206; CR-2207; CR-2208 GRP-COMP_OOOOA	6040a-RCP2COMP	Reciprocating compressors units at Plant 2
VCOMP-1; VCOMP-2	6040a-VRUCOMP	Reciprocating compressors units less than 1000 hp GRP-COMP_OOOOA
ECR-2212; ECR-2213; ECR-2214; ECF2215->ECR2215?	6040a-ECOMP GRP-ELECOMPRESS	Electric compressor units
E-VRUCOM1; E-VRUCOM2; E-VRUCOM3; E-VRUCOM4	6040a-EVRUCOMP GRP-ELECOMPRESS	Electric compressor units
FUG-1	6040a-PNEUCONTR	Sitewide pneumatic controllers at a Plant 1, 2 and 3
FUG-1	6040a-PNEUPUMP	Sitewide pneumatic pumps at Plant 1, 2 and 3
FUG-1	6040a-PUMPLL	Sitewide Pumps in light liquid service at Plant 1, 2 and 3
FUG-1	6040a-PRD	Sitewide Pressure relief devices at Plant 1, 2 and 3
FUG-1	6040a-VALVEOEL	Sitewide Open ended line valves at Plant 1, 2 and 3

Please let me know if you have any questions. Thank you!

Best Regards,

Emily L. Knodell
 Permit Reviewer
 TCEQ – APD – OP Section (Title V)
 (512) 239-3107

 How are we doing? Fill out our online customer satisfaction survey at www.tceq.texas.gov/customersurvey



Permit By Rule Supplemental Table (Page 2)
Table B: Claimed (not registered) Permits by Rule (30 TAC Chapter 106) for the Application Area
Texas Commission on Environmental Quality

Date	Permit Number	Regulated Entity Number
4/8/2025	4119	RN109161745

Unit ID No.	PBR No.	Version No./Date
MSS-COMP-BLD	106.359	Version No.1/Sept 10, 2013
MSS-VSS-BLD	106.359	Version No.1/Sept 10, 2013
MSS-TKC	106.359	Version No.1/Sept 10, 2013
MSS-DEFAULT	106.359	Version No.1/Sept 10, 2013
MSS-P&B	106.359	Version No.1/Sept 10, 2013
MSS-OTHER	106.359	Version No.1/Sept 10, 2013
PBR SUBPART U STORAGE TANKS	106.472; 106.473	Version No.2/Sept 4, 2000
GEN-1; GEN-2; GEN-3; GEN-4 and GEN-5	106.511	Version No.2/Sept 4, 2000

Texas Commission on Environmental Quality
Application Area-Wide Applicability Determinations and General Information
Form OP-REQ1
Federal Operating Permit Program

Date:	04/08/2025
Permit No.:	4119
RN No.:	RN109161745

For SOP applications, answer ALL questions unless otherwise directed.

◆ *For GOP applications, answer ONLY these questions unless otherwise directed.*

Form OP-REQ1: Page 87			
XII. NSR Authorizations (Attach additional sheets if necessary for sections E-J)			
E. PSD Permits and PSD Major Pollutants			
PSD Permit No.:	Issuance Date:	Pollutant(s):	
PSD Permit No.:	Issuance Date:	Pollutant(s):	
PSD Permit No.:	Issuance Date:	Pollutant(s):	
PSD Permit No.:	Issuance Date:	Pollutant(s):	
<i>If PSD Permits are held for the application area, please complete the Major NSR Summary Table located under the Technical Forms heading at: www.tceq.texas.gov/permitting/air/titlev/site/site_experts.html.</i>			
F. Nonattainment (NA) Permits and NA Major Pollutants			
NA Permit No.:	Issuance Date:	Pollutant(s):	
NA Permit No.:	Issuance Date:	Pollutant(s):	
NA Permit No.:	Issuance Date:	Pollutant(s):	
NA Permit No.:	Issuance Date:	Pollutant(s):	
<i>If NA Permits are held for the application area, please complete the Major NSR Summary Table located under the Technical Forms heading at: www.tceq.texas.gov/permitting/air/titlev/site/site_experts.html.</i>			
G. NSR Authorizations with FCAA § 112(g) Requirements			
NSR Permit No.:	Issuance Date:	NSR Permit No.:	Issuance Date:
NSR Permit No.:	Issuance Date:	NSR Permit No.:	Issuance Date:
NSR Permit No.:	Issuance Date:	NSR Permit No.:	Issuance Date:
NSR Permit No.:	Issuance Date:	NSR Permit No.:	Issuance Date:
◆ H. Title 30 TAC Chapter 116 Permits, Special Permits, Standard Permits, Other Authorizations (Other Than Permits By Rule, PSD Permits, NA Permits) for the Application Area			
Authorization No.: 140834	Issuance Date: 06/15/2021	Authorization No.:	Issuance Date:
Authorization No.:	Issuance Date:	Authorization No.:	Issuance Date:
Authorization No.:	Issuance Date:	Authorization No.:	Issuance Date:
Authorization No.:	Issuance Date:	Authorization No.:	Issuance Date:

**Texas Commission on Environmental Quality
Form OP-ACPS
Application Compliance Plan and Schedule**

Date: 4/08/2025	Regulated Entity No.: RN109161745	Permit No.: CN605077106
Company Name: Brazos Midstream Operating LLC		Area Name: Comanche Plant

- Part 1 of this form must be submitted with all initial FOP applications and renewal applications.
- The Responsible Official must use Form OP-CRO1 (Certification by Responsible Official) to certify information contained in this form in accordance with 30 TAC § 122.132(d)(8).

Part 1

A. Compliance Plan — Future Activity Committal Statement	
<p>The <i>Responsible Official</i> commits, utilizing reasonable effort, to the following: As the responsible official it is my intent that all emission units shall continue to be in compliance with all applicable requirements they are currently in compliance with, and all emission units shall be in compliance by the compliance dates with any applicable requirements that become effective during the permit term.</p>	
B. Compliance Certification - Statement for Units in Compliance* (Indicate response by entering an "X" in the appropriate column)	
1. With the exception of those emission units listed in the Compliance Schedule section of this form (Part 2, below), and based, at minimum, on the compliance method specified in the associated applicable requirements, are all emission units addressed in this application in compliance with all their respective applicable requirements as identified in this application?	<input checked="" type="checkbox"/> YES <input type="checkbox"/> NO
2. Are there any non-compliance situations addressed in the Compliance Schedule Section of this form (Part 2)?	<input type="checkbox"/> YES <input checked="" type="checkbox"/> NO
3. If the response to Item B.2, above, is "Yes," indicate the total number of Part 2 attachments included in this submittal. <i>(For reference only)</i>	
<p>* For Site Operating Permits (SOPs), the complete application should be consulted for applicable requirements and their corresponding emission units when assessing compliance status. For General Operating Permits (GOPs), the application documentation, particularly Form OP-REQ1 should be consulted as well as the requirements contained in the appropriate General Permits portion of 30 TAC Chapter 122.</p> <p>Compliance should be assessed based, at a minimum, on the required monitoring, testing, record keeping, and/or reporting requirements, as appropriate, associated with the applicable requirement in question.</p>	

From: Arthi Reddy
To: Emily Knodell
CC: Gordon Moore; Gary Mann
Subject: RE: Technical Review -- FOP 04119/Project 37272, Brazos Midstream Operating, LLC/Comanche Plant
Date: Tuesday, April 8, 2025 1:31:59 PM
Attachments: image001.png
image002.png
image003.png
Additional information_FOP04119-082025.pdf

Hi Ms. Emily:

Please see attached the additional information requested. Please let me know if you have any questions or need anything else.

Thanks
Arthi Reddy

From: Emily Knodell <Emily.Knodell@tceq.texas.gov>
Sent: Friday, April 4, 2025 3:15 PM
To: Gary Mann <mann@brazosmidstream.com>
Subject: RE: Technical Review -- FOP 04119/Project 37272, Brazos Midstream Operating, LLC/Comanche Plant

CAUTION: This email originated from outside of the organization. Do not click links or open attachments unless you recognize the sender and know the content is safe.

Good afternoon Gary,

Technical review for this project is moving along. During my review, I came across the items listed below. Please resolve by **04/11/2025**.

1. **Form OP-PBRSUP:** Please include an OP-PBRSUP for this application. This form is required for all renewal applications submitted on or after August 1, 2020, where PBRs are used to authorize emission units in the permit area. Please submit the table in full, including tables A, B, C, and D as a set with matching dates on each table. (No table should be blank, but "none" or "NA" can be used on a table as appropriate, this allows the public to know a table was not inadvertently left out and that the site is not using any insignificant PBRs).
2. **Form OP-ACPS:** Please include an OP-ACPS, as this is required form in a renewal application.
3. **Form OP-REQ1, Page 87:** For NSR 140834, there is a more recent issuance date listed in IDA, amendment issued 06/15/2021. Would you like to incorporate this date into the renewal? If so, please send an updated Form OP-REQ1, Page 87 which lists the newer date for NSR 140834.

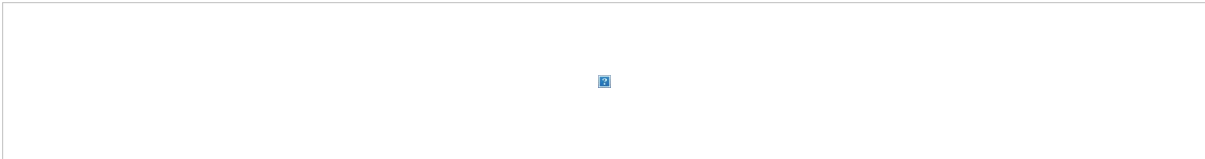

Please do not hesitate to reach out if you have any questions. Thank you!

Best Regards,

Emily L. Knodell
Permit Reviewer
TCEQ – APD – OP Section (Title V)
(512) 239-3107

 How are we doing? Fill out our online customer satisfaction survey at www.tceq.texas.gov/customersurvey

From: Emily Knodell
Sent: Tuesday, October 29, 2024 1:52 PM
To: Gary Mann <mann@brazosmidstream.com>
Subject: RE: Technical Review -- FOP 04119/Project 37272, Brazos Midstream Operating, LLC/Comanche Plant

Hi Gary,

Thanks for letting me know.

Emily L. Knodell
Permit Reviewer
TCEQ – APD – OP Section (Title V)
(512) 239-3107

 How are we doing? Fill out our online customer satisfaction survey at www.tceq.texas.gov/customersurvey

From: Gary Mann <mann@brazosmidstream.com>
Sent: Monday, October 28, 2024 11:14 AM
To: Emily Knodell <Emily.Knodell@tceq.texas.gov>
Subject: RE: Technical Review -- FOP 04119/Project 37272, Brazos Midstream Operating, LLC/Comanche Plant

Emily,

Thank you, we have received your email and have read the instructions. A copy of the application has already been emailed to Region 6. If you have any questions, please let me know.

Thanks,

Gary Mann • Safety & Compliance Director

O: (817) 332-6800
D: (817) 806-1104
C: (682) 429-4839
mann@brazosmidstream.com
777 Main St. / Suite 3700 / Fort Worth, TX 76102



From: Emily Knodell <Emily.Knodell@tceq.texas.gov>
Sent: Monday, October 28, 2024 9:33 AM
To: Gary Mann <mann@brazosmidstream.com>
Subject: Technical Review -- FOP 04119/Project 37272, Brazos Midstream Operating, LLC/Comanche Plant

You don't often get email from emily.knodell@tceq.texas.gov. [Learn why this is important](#)

CAUTION: This email originated from outside of the organization. Do not click links or open attachments unless you recognize the sender and know the content is safe.

Good morning Mr. Gary Mann,

My name is Emily Knodell and I have been assigned to the Federal Operating Permit (FOP) *renewal* application of Permit No. **O4119** for **Brazos Midstream Operating, LLC/Comanche Plant**. This application has been assigned Project No. **37272**. Please address all correspondence pertaining to this permit application, including any updates, to me at the address below, and use both the Permit and Project reference numbers above to facilitate tracking.

In addition, I wanted to let you know that EPA has, on occasion, objected to Title V permits based on the following:

- a. NSR permit and PBR monitoring sufficiency –please refer to our periodic monitoring guidance for reference of monitoring that EPA has, so far, considered sufficient.
- b. Reference to confidential business information (CBI) in NSR permits and PBR submittals.
- c. High level terms in the SOP Applicable Requirement Summary Table. The high level terms are sometimes used in SOPs when unit attribute forms have not yet been updated due to regulatory amendments.
- d. Accuracy of PBR information provided on the supplemental table and in the permit – please refer to Forms OP-PBRSUP and OP-REQ1 Instructions.

If you have any questions or concerns on any of these items or think you need to do any additional updates, let me know and we can discuss further.

Application updates may now be submitted through Title V STEERS. Any application updates that are submitted by the RO/DAR through STEERS are certified and do not require the submittal of an original signature OP-CRO1. Application updates that are provided through email or physical mail require certification using an original signature OP-CRO1.

Please notify me when these updates have been submitted.

As required on Form OP-1, question IV.D, please remember the FOP application and all application updates must be submitted to EPA Region 6 at R6AirPermitsTX@epa.gov and to the TCEQ regional office having jurisdiction. This submittal information can be found on our website at [Where to Submit FOP Applications and Permit-Related Documents](#).

Please review the "SOP Technical Review Fact Sheet" located at http://www.tceq.texas.gov/assets/public/permitting/air/Guidance/Title_V/sop_wdp_factsheet.pdf. This guidance contains important information regarding the review process and application update procedures. Contact me if you have any questions regarding the guidelines, the project schedule, or any other details regarding your application or permit.

I would appreciate a quick confirmation that this email has reached you.

Thank you for your cooperation.

Sincerely,

Emily L. Knodell
Permit Reviewer
OA/Air Permits Division/OP Section
Texas Commission on Environmental Quality
MC-163, P.O. Box 13087
Austin, TX 78711-3087
emily.knodell@tceq.texas.gov

Phone: (512) 239-3107
Fax: (512) 239-1400



How are we doing? Fill out our online customer satisfaction survey at www.tceq.texas.gov/customersurvey

Carolyn Thomas

From: eNotice TCEQ
Sent: Wednesday, October 16, 2024 9:13 AM
To: cesar.blanco@senate.texas.gov; Andrew.murr@house.texas.gov
Subject: TCEQ Notice - Permit Number O4119
Attachments: TCEQ Notice - O4119_37272.pdf

This email is being sent to electronically transmit an official document issued by the Office of Air of the Texas Commission on Environmental Quality.

This email is being sent to you because either (a) you filed a document with the Office of the Chief Clerk that made you part of the official mailing list for the above referenced matter, or (b) notice to you is legally required. As authorized by Texas Water Code 5.128, this electronic transmittal is replacing the previous practice of hard copy distribution. Amendments to Texas Government Code 552.137 prompted a change to the agency's privacy policy regarding confidentiality of certain email addresses. The revised privacy policy can be viewed at http://www.tceq.state.tx.us/help/policies/electronic_info_policy.html.

Questions regarding this email may be submitted either by replying directly to this email or by calling Mr. Jesse Chacon, P.E. with the Air Permits Division at (512) 239-5759.

The attached document is provided in an Adobe Acrobat .pdf format. If you cannot display the attachment, you may need to visit the Adobe web site (<http://get.adobe.com/reader>) to download the free Adobe Acrobat Reader software.

Jon Niermann, *Chairman*
Bobby Janecka, *Commissioner*
Catarina R. Gonzales, *Commissioner*
Kelly Keel, *Executive Director*



TEXAS COMMISSION ON ENVIRONMENTAL QUALITY

Protecting Texas by Reducing and Preventing Pollution

October 16, 2024

THE HONORABLE CESAR BLANCO
TEXAS SENATE
PO BOX 12068
AUSTIN TX 78711-2068

Re: Accepted Federal Operating Permit Renewal Application
Project Number: 37272
Permit Number: O4119
Brazos Midstream Operating, LLC
Comanche Plant
Pecos, Reeves County
Regulated Entity Number: RN109161745
Customer Reference Number: CN605077106

Dear Senator Blanco:

This letter notifies you that the Texas Commission on Environmental Quality has received a federal operating permit (FOP) renewal application for a site located in your district. As part of this permitting process, the applicant is required to publish a formal newspaper public notice. The notice will inform the public of their right to make comments or request a public hearing. This link to an electronic map of the site or facility's general location is provided as a public courtesy and not part of the application or notice. For exact location, refer to application. <https://gisweb.tceq.texas.gov/LocationMapper/?marker=-103.209444,31.313333&level=13>.

The FOP program regulates both new and existing major sources of emissions. The goal of the program is to improve air quality in Texas through increased compliance by codifying existing applicable regulatory requirements into the FOP. The FOP provides the applicant authorization to operate the equipment at the site. The FOP identifies and codifies air emission requirements (known as applicable requirements) that apply to the emission units at the site. The FOP does not authorize construction of emission units or emissions from those units. The New Source Review (NSR) permit is the mechanism for these authorizations.

The Honorable Cesar Blanco
Page 2
October 16, 2024

Re: Accepted Federal Operating Permit Renewal Application

This letter is being sent to you for information only and no action is required. If you need further information, please contact me at (512) 239-1250.

Sincerely,

A handwritten signature in black ink, appearing to read "Samuel Short", followed by a long horizontal line extending to the right.

Samuel Short, Deputy Director
Air Permits Division
Office of Air
Texas Commission on Environmental Quality

Jon Niermann, *Chairman*
Bobby Janecka, *Commissioner*
Catarina R. Gonzales, *Commissioner*
Kelly Keel, *Executive Director*



TEXAS COMMISSION ON ENVIRONMENTAL QUALITY

Protecting Texas by Reducing and Preventing Pollution

October 16, 2024

THE HONORABLE ANDREW MURR
TEXAS HOUSE OF REPRESENTATIVES
PO BOX 2910
AUSTIN TX 78768-2910

Re: Accepted Federal Operating Permit Renewal Application
Project Number: 37272
Permit Number: O4119
Brazos Midstream Operating, LLC
Comanche Plant
Pecos, Reeves County
Regulated Entity Number: RN109161745
Customer Reference Number: CN605077106

Dear Representative Murr:

This letter notifies you that the Texas Commission on Environmental Quality has received a federal operating permit (FOP) renewal application for a site located in your district. As part of this permitting process, the applicant is required to publish a formal newspaper public notice. The notice will inform the public of their right to make comments or request a public hearing. This link to an electronic map of the site or facility's general location is provided as a public courtesy and not part of the application or notice. For exact location, refer to application. <https://gisweb.tceq.texas.gov/LocationMapper/?marker=-103.209444,31.313333&level=13>.

The FOP program regulates both new and existing major sources of emissions. The goal of the program is to improve air quality in Texas through increased compliance by codifying existing applicable regulatory requirements into the FOP. The FOP provides the applicant authorization to operate the equipment at the site.

This letter is being sent to you for information only and no action is required. If you need further information, please contact me at (512) 239-1250.

Sincerely,

A handwritten signature in black ink, appearing to read "Samuel Short", with a long horizontal line extending to the right.

Samuel Short, Deputy Director
Air Permits Division
Office of Air
Texas Commission on Environmental Quality

Texas Commission on Environmental Quality

Title V Existing

4119

Site Information (Regulated Entity)

What is the name of the permit area to be authorized?	COMANCHE PLANT
Does the site have a physical address?	No
Because there is no physical address, describe how to locate this site:	FROM THE INTX OF US 285 & S CEDAR ST GO 3.2 MI & TURN L ON FM RD 1450 E GO 15. MI & THEN TURN R GO 0.8 MI TOWARDS THE FACILITY LOCATION
City	PECOS
State	TX
ZIP	79772
County	REEVES
Latitude (N) (##.#####)	31.313333
Longitude (W) (-###.#####)	103.209444
Primary SIC Code	1321
Secondary SIC Code	
Primary NAICS Code	211112
Secondary NAICS Code	
Regulated Entity Site Information	
What is the Regulated Entity's Number (RN)?	RN109161745
What is the name of the Regulated Entity (RE)?	COMANCHE PLANT
Does the RE site have a physical address?	No
Because there is no physical address, describe how to locate this site:	FROM PECOS, TX TAKE US-285 S/S CEDAR ST AND GO 3.2 MILES. TURN LEFT ONTO FM 1450 E AND DRIVE 15.1 MILES AND THEN TURN RIGHT AND GO 0.8 MILE TOWARDS THE FACILITY LOCATION.
City	PECOS
State	TX
ZIP	79772
County	REEVES
Latitude (N) (##.#####)	31.313222
Longitude (W) (-###.#####)	-103.226028
Facility NAICS Code	
What is the primary business of this entity?	NATURAL GAS PLANT

Customer (Applicant) Information

How is this applicant associated with this site?	Owner Operator
What is the applicant's Customer Number (CN)?	CN605077106
Type of Customer	Corporation
Full legal name of the applicant:	
Legal Name	Brazos Midstream Operating, LLC
Texas SOS Filing Number	802169329

Federal Tax ID	
State Franchise Tax ID	32056577227
State Sales Tax ID	
Local Tax ID	
DUNS Number	86549467
Number of Employees	0-20
Independently Owned and Operated?	Yes

Responsible Official Contact

Person TCEQ should contact for questions about this application:

Organization Name	Brazos Operating LLC
Prefix	MR
First	Justin
Middle	
Last	Beto
Suffix	
Credentials	
Title	VP of Operations
Enter new address or copy one from list:	
Mailing Address	
Address Type	Domestic
Mailing Address (include Suite or Bldg. here, if applicable)	777 MAIN ST STE 3700
Routing (such as Mail Code, Dept., or Attn:)	
City	FORT WORTH
State	TX
ZIP	76102
Phone (###-###-####)	8173326800
Extension	
Alternate Phone (###-###-####)	
Fax (###-###-####)	
E-mail	beto@brazosmidstream.com

Duly Authorized Representative Contact

Person TCEQ should contact for questions about this application

Select existing DAR contact or enter a new contact.	New Contact
Organization Name	Brazos Midstream Operating LLC
Prefix	MR
First	Justin
Middle	
Last	Beto
Suffix	
Credentials	
Title	VP of Operations
Enter new address or copy one from list	Responsible Official Contact Address
Mailing Address	

Address Type	Domestic
Mailing Address (include Suite or Bldg. here, if applicable)	777 MAIN ST STE 3700
Routing (such as Mail Code, Dept., or Attn:)	
City	FORT WORTH
State	TX
Zip	76102
Phone (###-###-####)	8173326800
Extension	
Alternate Phone (###-###-####)	
Fax (###-###-####)	
E-mail	beto@brazosmidstream.com

Technical Contact

Person TCEQ should contact for questions about this application:

Select existing TC contact or enter a new contact.

Organization Name

Prefix

First

Middle

Last

Suffix

Credentials

Title

Enter new address or copy one from list:

Mailing Address

Address Type

Mailing Address (include Suite or Bldg. here, if applicable)

Routing (such as Mail Code, Dept., or Attn:)

City

State

ZIP

Phone (###-###-####)

Extension

Alternate Phone (###-###-####)

Fax (###-###-####)

E-mail

GARY MANN(BRAZOS MIDSTREA...)

BRAZOS MIDSTREAM OPERATING LLC

MR

GARY

MANN

COMPLIANCE MANAGER

Domestic

3017 W 7TH ST

STE 300

FORT WORTH

TX

76107

6824294839

mann@brazosmidstream.com

Title V General Information - Existing

1) Permit Type:

2) Permit Latitude Coordinate:

3) Permit Longitude Coordinate:

4) Is this submittal a new application or an update to an existing application?

4.1. What type of permitting action are you applying for?

SOP

31 Deg 18 Min 48 Sec

103 Deg 12 Min 34 Sec

New Application

Renewal

4.1.1. Are there any permits that should be voided upon issuance of this permit application through permit conversion?	No
4.1.2. Are there any permits that should be voided upon issuance of this permit application through permit consolidation?	No
5) Who will electronically sign this Title V application?	Responsible Official
6) Does this application include Acid Rain Program or Cross-State Air Pollution Rule requirements?	No

Title V Attachments Existing

Attach OP-1 (Site Information Summary)

Attach OP-2 (Application for Permit Revision/Renewal)

Attach OP-ACPS (Application Compliance Plan and Schedule)

Attach OP-REQ1 (Application Area-Wide Applicability Determinations and General Information)

Attach OP-REQ2 (Negative Applicable Requirement Determinations)

Attach OP-REQ3 (Applicable Requirements Summary)

Attach OP-PBRSUP (Permits by Rule Supplemental Table)

Attach OP-SUMR (Individual Unit Summary for Revisions)

Attach OP-MON (Monitoring Requirements)

Attach OP-UA (Unit Attribute) Forms

If applicable, attach OP-AR1 (Acid Rain Permit Application)

Attach OP-CRO2 (Change of Responsible Official Information)

[File Properties]

File Name	OP-CRO2_Signed.pdf
Hash	643DF618FA7B306825A9F69AE4D445DCB7B8A0672C91A4EBE8C9F3253C4F4B3E
MIME-Type	application/pdf

Attach OP-DEL (Delegation of Responsible Official)

Attach any other necessary information needed to complete the permit.

[File Properties]

File Name	Comanche Title V Renewal Application 10102024.pdf
Hash	3FCEC0EE917AED22D12A8F6301368829457215443C55583FE5C67D6B4734F939
MIME-Type	application/pdf

An additional space to attach any other necessary information needed to complete the permit.

Expedite Title V

1) Per Texas Health and Safety Code, Section 382.05155, does the applicant want to expedite the processing of this application? No

Certification

I certify that I am the Responsible Official for this application and that, based on information and belief formed after reasonable inquiry, the statements and information on this form are true, accurate, and complete.

1. I am Justin D Beto, the owner of the STEERS account ER101679.
2. I have the authority to sign this data on behalf of the applicant named above.
3. I have personally examined the foregoing and am familiar with its content and the content of any attachments, and based upon my personal knowledge and/or inquiry of any individual responsible for information contained herein, that this information is true, accurate, and complete.
4. I further certify that I have not violated any term in my TCEQ STEERS participation agreement and that I have no reason to believe that the confidentiality or use of my password has been compromised at any time.
5. I understand that use of my password constitutes an electronic signature legally equivalent to my written signature.
6. I also understand that the attestations of fact contained herein pertain to the implementation, oversight and enforcement of a state and/or federal environmental program and must be true and complete to the best of my knowledge.
7. I am aware that criminal penalties may be imposed for statements or omissions that I know or have reason to believe are untrue or misleading.
8. I am knowingly and intentionally signing Title V Existing 4119.
9. My signature indicates that I am in agreement with the information on this form, and authorize its submittal to the TCEC

OWNER OPERATOR Signature: Justin D Beto OWNER OPERATOR

Account Number: ER101679
Signature IP Address: 74.122.233.151
Signature Date: 2024-10-14
Signature Hash: A1B1DEC93641DE95D256AD3B740E46F634FC00798BE6ED7608E03F4CF01E415B
Form Hash Code at time of Signature: F9FD853B429148344D75FD16D112C7B0ABAD7C1EDE5B1773D6A14B7B5B4FB514

Submission

Reference Number: The application reference number is 646733
Submitted by: The application was submitted by ER101679/Justin D Beto
Submitted Timestamp: The application was submitted on 2024-10-14 at 14:13:47 CDT
Submitted From: The application was submitted from IP address 74.122.233.151
Confirmation Number: The confirmation number is 571310
Steers Version: The STEERS version is 6.82
Permit Number: The permit number is 4119

Additional Information

Application Creator: This account was created by Arthi R Reddy



**BRAZOS MIDSTREAM OPERATING LLC
(CUSTOMER NUMBER 605077106)**

**COMANCHE PLANT
REEVES COUNTY, TEXAS
RN109161745**

**RENEWAL/REVISION APPLICATION FOR
AUTHORIZATION TO OPERATE UNDER
TITLE V SITE OPERATING PERMIT**

OCTOBER 2024

PREPARED BY:



**2001 EAST 70TH STREET, SUITE 503
SHREVEPORT, LOUISIANA 71105
(318) 797-8636
CK ASSOCIATES' PROJECT NO. 13574**

TABLE OF CONTENTS

Section

1.0 INTRODUCTION & PROCESS DESCRIPTION

2.0 TCEQ SOP FORMS

Form 10400	TCEQ Core Data Form
Form OP-1	Site Information Summary
Form OP-2	Application for Permit Revision/Renewal
Form OP-CRO1	Certification by Responsible Official
Form OP-REQ1	Application Area-Wide Applicability Determinations and General Information
Form OP-REQ2	Negative Applicable/Superseded Requirements Determination
Form OP-REQ3	Applicable Requirements Summary
Form OP-UA	Unit Attribute Forms
Form OP-SUMR	Individual Unit Summary for Revisions
Form OP-MON	Monitoring Requirements

3.0 Figures

Figure 1	Process Flow Diagram
Figure 2	Site Location Map

**SECTION 1.0
INTRODUCTION & PROCESS DESCRIPTION**

1.0 INTRODUCTION

Brazos Midstream Operating LLC (Brazos) owns and operates the Comanche Plant located in Reeves County, Texas. The facility is currently operating under updated TCEQ Standard Permit Registration No. 140834 issued June 27, 2016 and Title V SOP Permit # O4119. With this submittal, Brazos is submitting a renewal application including minor revisions 6 months before the expiration date of the current permit which is April 15, 2025. A renewal application received before October 15, 2024 is considered timely. Brazos is requesting coverage continued coverage under the SOP for its facility equipment and operations as stated in this application.

Brazos is providing all the necessary forms for the above-named SOP in accordance with 40 CFR Part 70 and 30 TAC Chapter 122 for renewal of the Title V Permit as per TCEQ SOP Renewal Guidance. These forms include OP-CRO1, OP-2, OP-2, OP-REQ1, OP-PBRSUP (OP-REQ2, OP-REQ3, OP-SUMR, OP-UA forms, OP-MON, OP-SUM, facility area map, and process flow diagram).

PROCESS DESCRIPTION

The Comanche Plant is located near Pecos, Reeves County, Texas. The facility consists of three co-located gas processing trains called Comanche I, II and III. Each train has a similar process sequence, as described herein.

Normal Operating Scenario

Inlet Gas

Unprocessed natural gas is delivered to the facility through gathering pipelines which are connected to producer's facilities. The gas delivered to the plant contains a mixture of hydrocarbons that is produced from oil and gas wells. The inlet gas also contains water vapor and hydrogen sulfide (not to exceed an annual average of 15 ppmv) incidental to oil and gas well production. The inlet stream passes through a slug catcher where the liquids are initially separated from the natural gas. Liquids exit the bottom of the vessel and the natural gas exits the top for further processing. The facility design capacity is at 460 MMSCFD, as follows: 60 MMSCFD at Comanche Plant I, 200 MMSCFD at Comanche Plant II and 200 MMSCFD at Comanche Plant III. The facility is limiting the annual average H₂S concentration to 15 ppm from all the three plants combined.

Condensate Stabilization

The condensate stabilization is processed at Plant I and Plant II. Condensate from Plant III flows to the Plant II stabilizer. The separated liquids stream flow into condensate surge vessels located at Plant I and II prior to stabilization. The stream passes through the two-stage separator, which separates the condensate and produced water streams. The produced water stream is sent to produced water tanks. The condensate stream then flows to a stabilization unit. The stream is first preheated in the inlet heat exchanger and flows into the stabilization tower. The light components rise and exit the overhead vapor outlet. The heavier liquid components descend and pass through the indirect heater resulting in additional vapor to flash off, rise and exit the tower. Stabilized liquids collect in the bottom of the tower. They are routed to the inlet heat exchanger to cool and then routed to condensate storage tanks. Plant I is equipped with four condensate storage tanks and one produced water storage tank. Plant II and III have a shared set of fourteen

condensate storage tanks and two produced water tanks. Plant I is rated at 1500 BOPD and Plant II and III are rated at 5000 BOPD each. The stabilized condensate is periodically removed from the site via tank truck loading. The produced water stored is periodically removed from the site by transport trucks. The condensate storage tanks are controlled by flare at all times. The produced water tank at Comanche I is controlled. The produced water tanks that serve Plant II and III are vented to the atmosphere. The overhead vapor stream from the condensate surge vessels and the stabilizer are recovered for compression using both natural gas fired and electric overhead compressors and/or recycled back into the inlet header of the gas processing unit for processing.

Amine Treating

Acid gases (hydrogen sulfide and carbon dioxide) in the natural gas stream are removed using amine treating process. The site is equipped with three amine units; one processing train at each plant. The natural gas stream entering the facility is run through a tower which contains the amine solution that absorb the acid gases from the natural gas as it passes through the tower. The amine solution is regenerated allowing it to be reused. The acid gases are routed to the thermal oxidizer for combustion. This process is identical at all the three trains. Each train will have its own thermal oxidizer to capture emissions for combustion from the amine units located at each train. The emissions from the amine regenerator at Plant II will be routed to the thermal oxidizer and the flash gas to the facility main flare. The emissions from the flash and the regenerator from amine unit at Plant I Plant III will be controlled by the thermal oxidizer alone.

Mol Sieve Dehydration and TEG Dehydration

The first processing train (Plant I) utilizes the mol sieve dehydration process. The recovery process of the gas trains utilizes "cryogenic" technology, and thus the inlet gas must be essentially free of water. The mole sieve dehydration is used in the water removal process. Separated inlet gas is passed through a vessel filled with dry desiccant material (Molecular Sieve) where the water vapor is adsorbed into the desiccant, allowing the gas from the material to be essentially water free. The process includes parallel mol sieve vessel which operate alternatively in dehydration/regeneration mode. As the dehydrated unit becomes saturated with water vapor, it is automatically switched to regeneration mode while a separate parallel vessel becomes active in dehydration mode. Plant II and III natural gas processing trains utilize the TEG dehydration process. The treated natural gas will be routed to the TEG dehydration units for the removal of water. The flash from the dehydration process will be controlled differently at Plant II and III. The flash gas from the dehydrator unit at Plant II is controlled by the facility main flare whereas at Plant III the flash gas is routed to the thermal oxidizer. The dehydration units at both Plant II and Plant III are equipped with a condenser; any non-condensable not condensed is routed to the thermal oxidizer for combustion at both Plant II and Plant III.

Cryogenic Process

Actual recovery of condensable hydrocarbons (LPG) takes place in each of the cryogenic process that includes numerous exchangers and a demethanizer tower. High pressure, water free, inlet gas is received from the dehydration operation and the temperature of the inlet gas is reduced from its original temperature to allow for LPG extraction. At these extremely cold temperatures, condensable hydrocarbons are liquefied and recovered. The RSV process is utilized to improve NGL recover efficiency for Plants II and III. The dry natural gas (primarily methane) is compressed and delivered through plant piping to

pipelines as a finished product.

Truck Loading –Stabilized Condensate

The stabilized condensate is stored in the storage tanks is sent off-site for sales via truck loading. The vapors from truck loading are controlled by flare during loading operations. A vapor loading collection efficiency of 98.7% is assumed for the trucks (according to TCEQ Guidance) that are tested in a manner consistent with the NSPS standards. The captured loading vapors are routed to flare with a 98% destruction efficiency of emissions.

Truck Loading (Produced Water & Slop Oil Loading)

Produced water comes in with the inlet gas and is separated in the inlet separator. The produced water is stored and periodically sent offsite via tank truck loading for disposal. The facility is also equipped with several process drain/slop tanks. The compressor drip oil that is stored in slop oil tanks are transferred offsite for disposal periodically. The slop tanks are uncontrolled.

Miscellaneous

Emission points for the miscellaneous processes of the facility include pilot emissions from the emergency/upset flare stacks, salt water/slop tank emissions, pressurized surge vessels, miscellaneous chemical storage tanks for which the facility is claiming applicable PBRs under Subchapter U, and pressurized bullet tanks; natural gas driven process heaters, and electric process heaters which do not require permitting, and fugitives from valves and fittings. The facility includes numerous valves, pumps, compressors, connectors, and other process safety relief valves. All process relief valves etc. are routed to a low-pressure vent system which collects any vapors and transports them to the flare for incineration. Plant II and Plant III are equipped with Recycle Split Vapor (RSV) units comprised of heat exchangers and pressurized vessels that take a residue gas stream and recycle it to provide a reflux for the existing separation process that improves ethane removal for an overall increases NGL removal efficiency. The RSV units are a pressurized system with no process vents and are for the purpose of improving existing process efficiency and do not change the facility throughput. RSV components are included under fugitive emission source. The facility is voluntarily claiming control efficiency for fugitive components in accordance with TCEQ 28 LAER monitoring program to satisfy the requirements in the specific standard permit 6002 and the federal requirements for natural gas processing plants. Most stringent control efficiency are being used for conservative emissions estimations. The facility is and will comply will the most stringent applicable LDAR monitoring for equipment leaks as required in the standard permit claimed and other state and federal requirements. The facility miscellaneous chemical storage tanks are permitted by rule under PBR Subchapter U and does not require permitting. Also, the facility is including emissions for gas analyzer venting. The facility has estimated and update facility- wide MSS emissions to include all three trains. The MSS emissions are claimed under PBR 106.359.

Compression

The facility is equipped with both natural gas-fired and electric residue gas compressors and vapor recover unit compressors. The number of compressors operating and the load

on the compressors is determined by the volume of residue gas available. The compressor engines utilize sweet, processed natural gas from the fuel gas system as their fuel supply.

Electric Generation

The facility is equipped with five (5) generators to provide back-up power as needed. The engines are limited to 100 hrs/yr and operated as emergency generators to provide power as needed.

MSS Emissions

Planned MSS emissions have been evaluated and are claimed under PBR 106.359. Planned MSS emissions include compressor and vessel blowdowns, purging, pigging, truck blowdowns, and other miscellaneous MSS emissions as per TCEQ guidance. The facility flare is used for unplanned emission events or upsets which are not permitted in this submittal. Any overhead from PSVs (pressure safety valves) are recovered for compression and reused either as fuel or any excess gas is routed to emergency/upset flare located at all three trains and flared. Any deviation from normal operations is considered as an upset where the emissions will be controlled by the flare. Such events are not being registered or evaluated in this submittal. The MSS emissions will not exceed the emission limits of PBR 106.4.

Alternate Operating Scenario AOS-1 and AOS-2

Brazos is proposing two Alternate Operating Scenarios at Plant II and Plant III to reflect a trade off in inlet H₂S to the amine processes. The Alternate Operating Scenarios (AOS-1 and AOS-2) will allow for variations in concentration of H₂S that is less than or equal to 20 ppm at either/or Plant II and Plant III. The H₂S content in the natural gas at Plant I will continue to remain at 15 ppm during normal and alternate operating scenarios. The average annual operating concentration plant wide will remain the same as currently permitted that is not to exceed 15 ppm at Plant I, II and III combined. The alternate operate scenarios will differ only in H₂S concentration in the incoming stream for amine treatment at Plant II and III from normal operations. All other processes, facility units and operations that process H₂S will continue to operate at an average H₂S of 15 ppm as currently permitted upstream and downstream of the amine unit at all the three plants.

Alternate Operating Scenario (AOS-1)

In the first proposed Alternate Operating Scenario (AOS-1), the H₂S content in the natural gas stream at Plant II and III will vary from the normal operations. Plant I will continue to operate as currently permitted during normal and alternate operating scenarios. The H₂S content of the gas treated in Plant I will remain at 15 ppm; the H₂S content of the gas treated in Plant II is proposed at 10 ppm; and the H₂S content of the gas treated in Plant III is proposed at and 20 ppm at Plant III. The amine treatment processes will remain the same. The emissions from the amine regenerator and flash gas at Plant I and Plant III are controlled by the thermal oxidizer. The emissions from the amine regenerator at Plant II is controlled by the thermal oxidizer and the flash gas is routed to the main facility plant flare at Plant II. The Plant II and III amine systems control device emissions will change proportionately with the change in H₂S content, but there is no overall increase (other than due to rounding in calculations).

Alternate Operating Scenario (AOS-2)

In the second proposed Alternate Operating Scenario (AOS-2), the H₂S content in the natural gas stream at Plant II and III will vary from the normal operations. Plant I will continue to operate as currently permitted during normal and alternate operating scenarios. The H₂S content of the gas treated in Plant I will remain at 15 ppm; the H₂S content of the gas treated in Plant II is proposed at 20 ppm; and the H₂S content of the gas treated in Plant III is proposed at 10 ppm at Plant III. The amine treatment processes will remain the same. The emissions from the amine regenerator and flash gas at Plant I and Plant III are controlled by the thermal oxidizer. The emissions from the amine regenerator at Plant II is controlled by the thermal oxidizer and the flash gas is routed to the main facility plant flare at Plant II. The Plant II and III amine systems control device emissions will change proportionately with the change in H₂S content, but there is no overall increase (other than due to rounding in calculations).

Emission Sources & Estimation Methodologies

Emission estimates from the Comanche Plant are conservatively based on the highest anticipated production rate. A summary of source specific emissions and discharge parameters are provided in Table 1(a) in Section 7.0. Emissions calculations are provided in Section 3.0. Emissions have been estimated using manufacture data, API/EPA/TCEQ emission factors and EPA/TCEQ approved software.

Emission calculations were generated using the current version of the TCEQ Oil and Gas Emissions Spreadsheet. Supporting documentation for emissions calculations and process simulations generated by Brazos for emissions evaluation and lab analyses are also included in Section 3.0. Emissions sources at the facility are described in the table below:

Emission Sources

Emissions sources at the facility are described in the table below:

EPN	Point Source Description	Authorization
FUG-1	Site wide Fugitives	SP #140834
CR-2201 thru CR2208	Residue Compressors 1 thru 11	SP #140834
ECR 2212 thru ECR 2215	Electric Residue Compression	SP #140834
VCOMP-1 thru VCOMP-2	VRU Compressor Engines 4 and 5	SP #140834
E-VRUCOM	Electric VRU Compressor Engines	SP #140834
GEN-1 thru GEN-5	Emergency Generator -1 thru 5	PBR 106.511
H-781	HMO Heater 1	SP #140834

EPN	Point Source Description	Authorization
H-741	Regen Gas Heater 1	SP #140834
AMINE-HTR1 thru AMINE- HTR3	Amine Regen Heater 1 thru 3	SP #140834
STB-HTR1; STB-HTR2	Stabilizer Heater 1 and 2	SP #140834
TEG-HT1; TEG-HT2	TEG Reboilers 1 thru 2	SP #140834
HMO-2 thru HMO-5	Hot Oil Heater 2 thru 5	SP #140834
HTR-3	Pre-Heater	SP #140834
TK-800 thru TK-803	Stabilized Condensate Tank, 500 bbl	SP #140834
TK-10730 thru TK-10746	Stabilized Condensate Tank, 750 bbl	SP #140834
TK-804	Produced Water Tank, 500 bbl	SP #140834
TK-10719 thru TK-10720	Produced Water Tank, 500 bbl	SP #140834
TK-2245	Slop/Oily Water Tank, 500 bbl	SP #140834
TK-100	Slop/Oily Water Tank, 210 bbl	SP #140834
TK-10717 thru TK-10718	Slop/Oily Water Tank, 500 bbl	SP #140834
TK-20717 thru TK-20718	Slop/Oily Water Tank, 500 bbl	SP #140834
TK-20705	Closed Drain Tank	SP #140834
BULLET- TANKS	Pressurized Bullet Tank	SP #140834
LOAD- CONDENSATE	Condensate Loading I	SP #140834
LOAD2- CONDENSATE	Condensate Loading II	SP #140834
LOAD- PRODUCED WATER/SLOP	Produced Water/Slop Oil Loading	SP #140834
LOAD2- PRODUCED WATER/SLOP	Produced Water/Slop Oil Loading II and III	SP #140834
TK-MET1 thru TK-MET6	Methanol Tanks, 1000 gal	SP #140834

EPN	Point Source Description	Authorization
DEHY-2	TEG Dehydrator -2	SP #140834
DEHY-3	TEG Dehydrator -3	SP #140834
AMINE-1	Amine Unit-1	SP #140834
AMINE-2	Amine Unit-2	SP #140834
AMINE-3	Amine Unit-3	SP #140834
ECF-1	Enclosed Flare	SP #140834
FL-4	Flare, II & III Tanks & Loading	SP #140834
TO-1A	Thermal Oxidizer	SP #140834
TO-2/AOS-1/AOS-2	Thermal Oxidizer	SP #140834
TO-3/AOS-1/AOS-2	Thermal Oxidizer	SP #140834
GC-VENT 1 thru 3	GC Analyzer-Vents	SP #140834
FL-1	Facility Upsets Flare Plant 1 Pilot	SP #140834
FL-2/AOS-1/AOS-2	Facility Upsets Flare Plant 2 Pilot	SP #140834
FL-3	Facility Upsets Flare Plant 3 Pilot	SP #140834
MSS	Facility-wide MSS *Refer to MSS Summary for complete list of MSS emission sources and EPNs	SP #140834

This updated submittal contains the required forms and supporting documentation for the Comanche Plant to obtain a SOP. A compilation of the applicable TCEQ forms is provided in Section 2.0.

Lab Analysis

The gas/condensate and NGL liquid and gas composition utilized are based on site specific process simulation stream composition data provided by Brazos and Promax simulations using the site-specific lab data.

Regulatory Applicability

The Comanche Plant is subject to the state and federal regulations. Brazos shall comply with all applicable control monitoring, reporting and recordkeeping requirements. All of the emission sources will meet the general regulatory requirements of the 6002 Standard Permit for Oil and Gas Facilities. A brief description of the regulatory conformance and compliance for Chapters 101 through 122, Chapter 116 including section 116.610, 116.615 and 116.620 for the specific Oil and Gas Standard Permit requirements, and Federal Requirements in 40 CFR 60, 61 and 63 are provided in Section 4.0.

TCEQ Summary of Emissions

FN / FACILITY IDENTIFICATION	EPN / Emission Source	Location	EPN / Emission Source	ESTIMATED EMISSIONS																		
				VOC		NOX		CO		PM10		PM2.5		SO2		Formaldehyde		Benzene		H2S		
				lbs/hr	tpy	lbs/hr	tpy	lbs/hr	tpy	lbs/hr	tpy	lbs/hr	tpy	lbs/hr	tpy	lbs/hr	tpy	lbs/hr	tpy	lbs/hr	tpy	
FUG-1	FUG-1	Comanche I, II and III	Stewide Fugitives	0.94	4.10	-	-	-	-	-	-	-	-	-	-	-	-	-	0.00	0.01	0.00	0.00
CR-2201	CR-2201	Comanche I	Residue Compressor-1, Cat G3606; 1775 hp	2.97	13.03	1.96	8.57	3.33	14.57	0.13	0.58	0.13	0.58	0.01	0.03	0.23	1.03	0.01	0.02	-	-	
CR-2202	CR-2202	Comanche I	Residue Compressor-2, Cat G3606; 1775 hp	2.97	13.03	1.96	8.57	3.33	14.57	0.13	0.58	0.13	0.58	0.01	0.03	0.23	1.03	0.01	0.02	-	-	
CR-2203	CR-2203	Comanche I	Residue Compressor-3, Cat G3606; 1775 hp	2.97	13.03	1.96	8.57	3.33	14.57	0.13	0.58	0.13	0.58	0.01	0.03	0.23	1.03	0.01	0.02	-	-	
CR-2204	CR-2204	Comanche I	Residue Compressor-4, Cat G3606; 1775 hp	2.97	13.03	1.96	8.57	3.33	14.57	0.13	0.58	0.13	0.58	0.01	0.03	0.23	1.03	0.01	0.02	-	-	
CR-2205	CR-2205	Comanche II	Residue Compressor-5, Cat G3608; 2500 hp	0.39	1.72	2.76	12.07	2.45	10.72	0.19	0.81	0.19	0.81	0.01	0.05	0.04	0.16	0.01	0.03	-	-	
CR-2206	CR-2206	Comanche II	Residue Compressor-6, Cat G3608; 2500 hp	0.39	1.72	2.76	12.07	2.45	10.72	0.19	0.81	0.19	0.81	0.01	0.05	0.04	0.16	0.01	0.03	-	-	
CR-2207	CR-2207	Comanche II	Residue Compressor-7, Cat G3608; 2500 hp	0.39	1.72	2.76	12.07	2.45	10.72	0.19	0.81	0.19	0.81	0.01	0.05	0.04	0.16	0.01	0.03	-	-	
CR-2208	CR-2208	Comanche II	Residue Compressor-8, Cat G3608; 2500 hp	0.39	1.72	2.76	12.07	2.45	10.72	0.19	0.81	0.19	0.81	0.01	0.05	0.04	0.16	0.01	0.03	-	-	
ECR-2212	ECR-2212	Comanche II	Electric Residue Compressor-1; 2500 hp	-	-	-	-	-	-	-	-	-	-	-	-	-	-	-	-	-	-	
ECR-2213	ECR-2213	Comanche II	Electric Residue Compressor-2; 2500 hp	-	-	-	-	-	-	-	-	-	-	-	-	-	-	-	-	-	-	
ECR-2214	ECR-2214	Comanche III	Electric Residue Compressor-3; 3550 hp	-	-	-	-	-	-	-	-	-	-	-	-	-	-	-	-	-	-	
ECR-2215	ECR-2215	Comanche III	Electric Residue Compressor-4; 3550 hp	-	-	-	-	-	-	-	-	-	-	-	-	-	-	-	-	-	-	
ECR-2216	ECR-2216	Comanche III	Electric Residue Compressor-5; 3550 hp	-	-	-	-	-	-	-	-	-	-	-	-	-	-	-	-	-	-	
ECR-2217	ECR-2217	Comanche III	Electric Residue Compressor-6; 3550 hp	-	-	-	-	-	-	-	-	-	-	-	-	-	-	-	-	-	-	
ECR-2218	ECR-2218	Comanche III	Electric Residue Compressor-7; 3550 hp	-	-	-	-	-	-	-	-	-	-	-	-	-	-	-	-	-	-	
VCOMP-1	VCOMP-1	Comanche I	VRU Compressor Engine -4; Waukesha 740 hp	0.29	1.29	0.82	3.57	1.39	6.07	0.13	0.57	0.13	0.57	0.00	0.02	0.10	0.43	0.01	0.05	-	-	
VCOMP-2	VCOMP-2	Comanche I	VRU Compressor Engine-5; Cummins 265 hp	0.44	1.94	0.29	1.28	0.50	2.18	0.04	0.17	0.04	0.17	0.00	0.01	0.04	0.15	0.00	0.01	-	-	
E-VRUCOM	E-VRUCOM	Comanche I, II and III	(4) VRU Electric Compressor	-	-	-	-	-	-	-	-	-	-	-	-	-	-	-	-	-	-	
H-781	H-781	Comanche I	HMO Heater 1	0.05	0.23	0.94	4.12	0.79	3.46	0.07	0.31	0.05	0.23	0.01	0.02	-	-	-	-	-	-	#REF!
H-741	H-741	Comanche I	Regen Gas Heater 1	0.05	0.23	0.94	4.12	0.79	3.46	0.07	0.31	0.05	0.23	0.01	0.02	-	-	-	-	-	-	#REF!
AMINE-HTR1	AMINE-HTR1	Comanche I	Amine Regen Heater 1	0.03	0.12	0.49	2.13	0.41	1.79	0.04	0.16	0.03	0.12	0.00	0.01	-	-	-	-	-	-	#REF!
STB-HTR1	STB-HTR1	Comanche I	Stabilizer Heater 1	0.01	0.06	0.25	1.12	0.21	0.94	0.02	0.08	0.01	0.06	0.00	0.01	-	-	-	-	-	-	#REF!
STB-HTR2	STB-HTR2	Comanche II and III	Stabilizer Heater 2; 14.1 MMBTUH	0.08	0.33	1.38	6.05	1.16	5.09	0.11	0.46	0.08	0.35	0.01	0.04	-	-	-	-	-	-	#REF!
TEG-HT1	TEG-HT1	Comanche II	TEG Reboiler 1	0.01	0.06	0.25	1.07	0.21	0.90	0.02	0.08	0.01	0.06	0.00	0.01	-	-	-	-	-	-	#REF!
TEG-HT2	TEG-HT2	Comanche III	TEG Reboiler 2	0.01	0.06	0.25	1.07	0.21	0.90	0.02	0.08	0.01	0.06	0.00	0.01	-	-	-	-	-	-	#REF!
HMO-2	HMO-2	Comanche II	Hot Oil Heater 2	0.18	0.79	3.29	14.43	2.77	12.12	0.25	1.10	0.19	0.82	0.02	0.09	-	-	-	-	-	-	#REF!
HMO-3	HMO-3	Comanche III	Hot Oil Heater 3	0.18	0.79	3.29	14.43	2.77	12.12	0.25	1.10	0.19	0.82	0.02	0.09	-	-	-	-	-	-	#REF!
AMINE-HTR2	AMINE-HTR2	Comanche II	Amine Heater 2	0.19	0.83	3.45	15.12	2.90	12.70	0.26	1.15	0.20	0.86	0.02	0.09	-	-	-	-	-	-	#REF!
AMINE-HTR3	AMINE-HTR3	Comanche III	Amine Heater 3	0.19	0.83	3.45	15.12	2.90	12.70	0.26	1.15	0.20	0.86	0.02	0.09	-	-	-	-	-	-	#REF!
HMO-4	HMO-4	Comanche III	Hot Oil Heater 4	0.03	0.13	0.56	2.45	0.47	2.06	0.04	0.19	0.03	0.14	0.00	0.01	-	-	-	-	-	-	#REF!
HMO-5	HMO-5	Comanche III	Hot Oil Heater 5	0.05	0.21	0.88	3.86	0.74	3.25	0.07	0.29	0.05	0.22	0.01	0.02	-	-	-	-	-	-	#REF!
HTR-3	HTR-3	Comanche II	Pre Heater	0.03	0.15	0.61	2.68	0.51	2.25	0.05	0.20	0.03	0.15	0.004	0.02	-	-	-	-	-	-	#REF!
ECF-1	TK-800 thru TK-803	Comanche I	Stabilized Condensate Tank, 500 bbl	*	*	*	*	*	*	*	*	*	*	*	*	*	*	*	*	*	*	*
FL-4	TK-10730 thru TK-1	Comanche II	Stabilized Condensate Tank, 750 bbl	*	*	*	*	*	*	*	*	*	*	*	*	*	*	*	*	*	*	*
FL-4	TK-10740 thru TK-1	Comanche II	Stabilized Condensate Tank, 750 bbl	*	*	*	*	*	*	*	*	*	*	*	*	*	*	*	*	*	*	*
ECF-1	TK-804	Comanche I	Produced Water Tank, 500 bbl	*	*	*	*	*	*	*	*	*	*	*	*	*	*	*	*	*	*	*
TK-10719	TK-10719	Comanche II, III	Produced Water Tank, 500	1.04	4.55	*	*	*	*	*	*	*	*	*	*	*	*	0.00	0.00	0.01	0.02	
TK-10720	TK-10720	Comanche II, III	Produced Water Tank, 500	1.04	4.55	*	*	*	*	*	*	*	*	*	*	*	*	0.00	0.00	0.01	0.02	

TCEQ Summary of Emissions

FN / FACILITY IDENTIFICATION	EPN / Emission Source	Location	EPN / Emission Source	ESTIMATED EMISSIONS																	
				VOC		NOX		CO		PM10		PM2.5		SO2		Formaldehyde		Benzene		H2S	
				lb/hr	tpy	lb/hr	tpy	lb/hr	tpy	lb/hr	tpy	lb/hr	tpy	lb/hr	tpy	lb/hr	tpy	lb/hr	tpy	lb/hr	tpy
TK-100	TK-100	Comanche I	Slop Oily Water Tank, 210 bbl	0.00	0.02	-	-	-	-	-	-	-	-	-	-	-	-	0.00	0.00	0.00	0.00
TK-2245	TK-2245	Comanche I	Slop/Oily Water Tank, 500, b1	0.01	0.04	-	-	-	-	-	-	-	-	-	-	-	-	0.00	0.00	0.00	0.00
TK-10717 thru TK-10718	TK-10717 thru TK-1	Comanche II	Slop/Oily Water Tank, 500, b1	0.01	0.07	-	-	-	-	-	-	-	-	-	-	-	-	0.00	0.00	0.00	0.00
TK-20717 thru TK-2	TK-20717 thru TK-2	Comanche III	Slop/Oily Water Tank, 500, b1	0.01	0.07	-	-	-	-	-	-	-	-	-	-	-	-	0.00	0.00	0.00	0.00
TK-20705	TK-20705	Comanche III	Closed Drain Tank	-	-	-	-	-	-	-	-	-	-	-	-	-	-	-	-	-	-
TK-MET1	TK-MET1	Comanche I	Methanol Tank, 1000 gal	0.01	0.06	-	-	-	-	-	-	-	-	-	-	-	-	-	-	-	-
TK-MET2	TK-MET2	Comanche I	Methanol Tank, 1000 gal	0.01	0.06	-	-	-	-	-	-	-	-	-	-	-	-	-	-	-	-
TK-MET3 thru TK-M	TK-MET3 thru TK-M	Comanche I, II and III	Methanol Tank, 1000 gal	0.06	0.24	-	-	-	-	-	-	-	-	-	-	-	-	-	-	-	-
BULLET-TANKS	BULLET-TANKS	Comanche I, II and III	Pressurized Bullet Tanks	-	-	-	-	-	-	-	-	-	-	-	-	-	-	-	-	-	-
ECF-1	LOAD-CONDENSA	Comanche I	Condensate Loading I	0.69	0.83	-	-	-	-	-	-	-	-	-	-	-	-	0.00	0.01	0.00	0.00
LOAD-PRODUCED WATER/SLOP	LOAD-PRODUCED WATER/SLOP	Comanche I	Produced Water/Slop Oil Loading Plant I	0.53	0.05	-	-	-	-	-	-	-	-	-	-	-	-	0.00	0.00	0.00	0.00
FL-4	LOAD2-CONDENSA	Comanche II	Condensate Loading II/III	1.38	5.57	-	-	-	-	-	-	-	-	-	-	-	-	0.01	0.04	0.00	0.00
PRODUCED WATER/SLOP	PRODUCED WATER/SLOP	Comanche II and III	Produced Water/Slop Oil Loading II and III	0.53	0.06	-	-	-	-	-	-	-	-	-	-	-	-	0.00	0.00	0.00	0.00
TO-2	DEHY-2	Comanche II	TEG Dehydrator-2	*	*	*	*	*	*	*	*	*	*	*	*	*	*	*	*	*	*
TO-3	DEHY-3	Comanche III	TEG Dehydrator-3	*	*	*	*	*	*	*	*	*	*	*	*	*	*	*	*	*	*
TO-1A	AMINE-1	Comanche I	Amine Unit-1	*	*	*	*	*	*	*	*	*	*	*	*	*	*	*	*	*	*
TO-2	AMINE-2	Comanche II	Amine Unit-2	*	*	*	*	*	*	*	*	*	*	*	*	*	*	*	*	*	*
TO-3	AMINE-3	Comanche III	Amine Unit-3	*	*	*	*	*	*	*	*	*	*	*	*	*	*	*	*	*	*
ECF-1	ECF-1	Comanche I	Plant 1 Enclosed Flare	1.22	2.00	0.20	0.87	0.39	1.72	0.00	0.02	0.00	0.01	0.02	0.08	-	-	0.01	0.01	0.00	0.00
TO-2	TO-2	Comanche II	Thermal Oxidizer	0.69	3.04	1.27	5.55	1.07	4.66	0.09	0.41	0.07	0.33	21.10	92.44	-	-	0.05	0.20	0.06	0.26
TO-3	TO-3	Comanche III	Thermal Oxidizer	1.26	5.53	1.80	7.89	1.51	6.63	0.13	0.57	0.11	0.48	21.11	92.44	-	-	0.05	0.21	0.06	0.26
FL-1	FL-1	Comanche I	Facility Upsets Flare Plant 1	0.00	0.00	0.01	0.02	0.00	0.02	0.00	0.00	0.00	0.00	0.00	0.00	-	-	0.00	0.00	0.00	0.00
FL-2	AMINE-2/DEHY-2-	Comanche II	Facility Main Flare Plant 2	1.70	7.43	0.97	4.23	1.92	8.42	0.04	0.16	0.03	0.12	0.00	0.01	-	-	0.01	0.03	0.00	0.00
FL-3	FL-3	Comanche III	Facility Upset Flare Plant 3	0.00	0.00	0.01	0.02	0.00	0.02	0.00	0.00	0.00	0.00	0.00	0.00	-	-	0.00	0.00	0.00	0.00
FL-4	FL-4	Comanche II and III	Plant 2 Process Flare	2.97	12.27	0.49	2.14	0.97	4.25	0.01	0.05	0.01	0.03	0.02	0.09	-	-	0.02	0.08	0.00	0.00
GC-VENT1	GC-VENT1	Comanche I	GC Analyzer-Vent	0.71	3.13	-	-	-	-	-	-	-	-	-	-	-	-	0.00	0.00	0.00	0.00
GC-VENT2	GC-VENT2	Comanche II	GC Analyzer-Vent	0.71	3.13	-	-	-	-	-	-	-	-	-	-	-	-	0.00	0.00	0.00	0.00
GC-VENT3	GC-VENT3	Comanche III	GC Analyzer-Vent	0.71	3.13	-	-	-	-	-	-	-	-	-	-	-	-	0.00	0.00	0.00	0.00
TO-1A	TO-1A	Comanche I	Thermal Oxidizer	0.11	0.48	0.74	3.23	0.62	2.72	0.06	0.25	0.04	0.18	6.33	27.74	-	-	0.00	0.02	0.07	0.30
TOTAL EMISSIONS PI-IS (lb/hr-TPY):				31.69	127.45	45.47	199.15	48.30	211.55	3.30	14.46	2.85	12.49	46.79	213.68	1.21	5.32	0.22	0.90	0.21	#REF!
MAXIMUM OPERATING SCHEDULE:				Hours/Day	24	Days/Week	7	Weeks/Year	52												

* Routed to control device.

Notes:

- Two Alternate Operating Scenarios (AOS-1 and AOS-2) may be utilized but do not result in increased facility wide emissions:
 - Under AOS-1, stabilizer overheads are routed to Plant III, resulting in Comanche Plant III Thermal Oxidizer (TO-03) having SO2 emissions of 28.14 lb/hr and 123.24 tpy and Comanche Plant II Thermal Oxidizer (TO-2) having SO2 emissions of 14.07 lb/hr and 61.63 tpy.
 - Under AOS-2, stabilizer overheads are routed to Plant II, resulting in Comanche Plant II Thermal Oxidizer (TO-02) having SO2 emissions of 28.14 lb/hr and 123.24 tpy and Comanche Plant III Thermal Oxidizer (TO-3) having SO2 emissions of 14.07 lb/hr and 61.63 tpy.
- GEN-1, GEN-2, GEN-3, GEN-4, and GEN-5 are authorized under 30 TAC 106.511.
- MSS is authorized under 30 TAC 106.359

**SECTION 2.0
TCEQ SOP FORMS**

**FORM 10400
TCEQ CORE DATA FORM**



TCEQ Core Data Form

For detailed instructions on completing this form, please read the Core Data Form Instructions or call 512-239-5175.

SECTION I: General Information

1. Reason for Submission (If other is checked please describe in space provided.)		
<input type="checkbox"/> New Permit, Registration or Authorization (Core Data Form should be submitted with the program application.)		
<input type="checkbox"/> Renewal (Core Data Form should be submitted with the renewal form)	<input checked="" type="checkbox"/> Other Update to RO Information	
2. Customer Reference Number (if issued)	Follow this link to search for CN or RN numbers in Central Registry**	3. Regulated Entity Reference Number (if issued)
CN 605077106		RN 109161745

SECTION II: Customer Information

4. General Customer Information		5. Effective Date for Customer Information Updates (mm/dd/yyyy)	
<input type="checkbox"/> New Customer <input type="checkbox"/> Update to Customer Information <input type="checkbox"/> Change in Regulated Entity Ownership <input type="checkbox"/> Change in Legal Name (Verifiable with the Texas Secretary of State or Texas Comptroller of Public Accounts) No change			
<i>The Customer Name submitted here may be updated automatically based on what is current and active with the Texas Secretary of State (SOS) or Texas Comptroller of Public Accounts (CPA).</i>			
6. Customer Legal Name (If an individual, print last name first: eg: Doe, John)		<i>If new Customer, enter previous Customer below:</i>	
7. TX SOS/CPA Filing Number	8. TX State Tax ID (11 digits)	9. Federal Tax ID (9 digits)	10. DUNS Number (if applicable)
11. Type of Customer:	<input type="checkbox"/> Corporation	<input type="checkbox"/> Individual	Partnership: <input type="checkbox"/> General <input type="checkbox"/> Limited
Government: <input type="checkbox"/> City <input type="checkbox"/> County <input type="checkbox"/> Federal <input type="checkbox"/> Local <input type="checkbox"/> State <input type="checkbox"/> Other	<input type="checkbox"/> Sole Proprietorship	<input type="checkbox"/> Other:	
12. Number of Employees		13. Independently Owned and Operated?	
<input type="checkbox"/> 0-20 <input type="checkbox"/> 21-100 <input type="checkbox"/> 101-250 <input type="checkbox"/> 251-500 <input type="checkbox"/> 501 and higher		<input type="checkbox"/> Yes <input type="checkbox"/> No	
14. Customer Role (Proposed or Actual) – as it relates to the Regulated Entity listed on this form. Please check one of the following			
<input type="checkbox"/> Owner <input type="checkbox"/> Operator <input type="checkbox"/> Owner & Operator <input type="checkbox"/> Other: <input type="checkbox"/> Occupational Licensee <input type="checkbox"/> Responsible Party <input type="checkbox"/> VCP/BSA Applicant			
15. Mailing Address:			
City	State	ZIP	ZIP + 4
16. Country Mailing Information (if outside USA)		17. E-Mail Address (if applicable)	
18. Telephone Number		19. Extension or Code	20. Fax Number (if applicable)

() -		() -
-------	--	-------

SECTION III: Regulated Entity Information

21. General Regulated Entity Information *(If 'New Regulated Entity' is selected, a new permit application is also required.)*

New Regulated Entity
 Update to Regulated Entity Name
 Update to Regulated Entity Information
 No change

The Regulated Entity Name submitted may be updated, in order to meet TCEQ Core Data Standards (removal of organizational endings such as Inc, LP, or LLC).

22. Regulated Entity Name *(Enter name of the site where the regulated action is taking place.)*

23. Street Address of the Regulated Entity: <i>(No PO Boxes)</i>							
	City		State		ZIP		ZIP + 4

24. County

If no Street Address is provided, fields 25-28 are required.

25. Description to Physical Location:

26. Nearest City	State	Nearest ZIP Code

Latitude/Longitude are required and may be added/updated to meet TCEQ Core Data Standards. (Geocoding of the Physical Address may be used to supply coordinates where none have been provided or to gain accuracy).

27. Latitude (N) In Decimal:			28. Longitude (W) In Decimal:		
Degrees	Minutes	Seconds	Degrees	Minutes	Seconds

29. Primary SIC Code <small>(4 digits)</small>	30. Secondary SIC Code <small>(4 digits)</small>	31. Primary NAICS Code <small>(5 or 6 digits)</small>	32. Secondary NAICS Code <small>(5 or 6 digits)</small>

33. What is the Primary Business of this entity? *(Do not repeat the SIC or NAICS description.)*

34. Mailing Address:							
	City		State		ZIP		ZIP + 4

35. E-Mail Address:

36. Telephone Number	37. Extension or Code	38. Fax Number <i>(if applicable)</i>

() -		() -
-------	--	-------

39. TCEQ Programs and ID Numbers Check all Programs and write in the permits/registration numbers that will be affected by the updates submitted on this form. See the Core Data Form instructions for additional guidance.

<input type="checkbox"/> Dam Safety	<input type="checkbox"/> Districts	<input type="checkbox"/> Edwards Aquifer	<input checked="" type="checkbox"/> Emissions Inventory Air	<input type="checkbox"/> Industrial Hazardous Waste
<input type="checkbox"/> Municipal Solid Waste	<input checked="" type="checkbox"/> New Source Review Air	<input type="checkbox"/> OSSF	<input type="checkbox"/> Petroleum Storage Tank	<input type="checkbox"/> PWS
<input type="checkbox"/> Sludge	<input type="checkbox"/> Storm Water	<input checked="" type="checkbox"/> Title V Air	<input type="checkbox"/> Tires	<input type="checkbox"/> Used Oil
<input type="checkbox"/> Voluntary Cleanup	<input type="checkbox"/> Wastewater	<input type="checkbox"/> Wastewater Agriculture	<input type="checkbox"/> Water Rights	<input checked="" type="checkbox"/> Other:

SECTION IV: Preparer Information

40. Name:	Gordon R. Moore, P.E	41. Title:	Sr.Engineer/Area Manager
42. Telephone Number	43. Ext./Code	44. Fax Number	45. E-Mail Address
(318) 797-8636		() -	gordon.moore@c-ka.com

SECTION V: Authorized Signature

46. By my signature below, I certify, to the best of my knowledge, that the information provided in this form is true and complete, and that I have signature authority to submit this form on behalf of the entity specified in Section II, Field 6 and/or as required for the updates to the ID numbers identified in field 39.

Company:	Brazos Midstream Operating LLC	Job Title:	VP Operations
Name (In Print):	Justin Beto	Phone:	(817) 332- 6800
Signature:		Date:	

**FORM OP-1
SITE INFORMATION SUMMARY**

**Federal Operating Permit Program
Site Information Summary
Form OP-1 (Page 1)
Texas Commission on Environmental Quality**

Please print or type all information. Direct any questions regarding this application form to the Air Permits Division at (512) 239-1250 or to the Texas Commission on Environmental Quality, Office of Air, Air Permits Division (MC 163), P.O. Box 13087, Austin, Texas 78711-3087.

I. Company Identifying Information
A. Company Name: Brazos Midstream Operating LLC
B. Customer Reference Number (CN): CN CN605077106
C. Submittal Date (mm/dd/yyyy): 30/09/2024
II. Site Information
A. Site Name: Comanche Plant
B. Regulated Entity Reference Number (RN): RN RN109161745
C. Indicate affected state(s) required to review permit application: <i>(Check the appropriate box[es].)</i>
<input type="checkbox"/> AR <input type="checkbox"/> CO <input type="checkbox"/> KS <input type="checkbox"/> LA <input type="checkbox"/> NM <input type="checkbox"/> OK <input checked="" type="checkbox"/> N/A
D. Indicate all pollutants for which the site is a major source based on the site's potential to emit: <i>(Check the appropriate box[es].)</i>
<input checked="" type="checkbox"/> VOC <input checked="" type="checkbox"/> NO _x <input checked="" type="checkbox"/> SO ₂ <input type="checkbox"/> PM ₁₀ <input checked="" type="checkbox"/> CO <input type="checkbox"/> Pb <input type="checkbox"/> HAPS
Other:
E. Is the site a non-major source subject to the Federal Operating Permit Program? <input type="checkbox"/> YES <input checked="" type="checkbox"/> NO
F. Is the site within a local program area jurisdiction? <input type="checkbox"/> YES <input checked="" type="checkbox"/> NO
G. Will emissions averaging be used to comply with any Subpart of 40 CFR Part 63? <input type="checkbox"/> YES <input checked="" type="checkbox"/> NO
H. Indicate the 40 CFR Part 63 Subpart(s) that will use emissions averaging:
III. Permit Type
A. Type of Permit Requested: <i>(Select only one response)</i>
<input checked="" type="checkbox"/> Site Operating Permit (SOP) <input type="checkbox"/> Temporary Operating Permit (TOP) <input type="checkbox"/> General Operating Permit (GOP)

**Federal Operating Permit Program
Site Information Summary
Form OP-1 (Page 2)
Texas Commission on Environmental Quality**

IV. Initial Application Information <i>(Complete for Initial Issuance Applications Only.)</i>	
A. Is this submittal an abbreviated or a full application?	<input type="checkbox"/> Abbreviated <input checked="" type="checkbox"/> Full
B. If this is a full application, is the submittal a follow-up to an abbreviated application?	<input type="checkbox"/> YES <input checked="" type="checkbox"/> NO
C. If this is an abbreviated application, is this an early submittal for a combined SOP and Acid Rain permit?	<input type="checkbox"/> YES <input type="checkbox"/> NO
D. Has an electronic copy of this application been submitted (or is being submitted) to EPA? (Refer to the form instructions for additional information.)	<input checked="" type="checkbox"/> YES <input type="checkbox"/> NO
V. Confidential Information	
A. Is confidential information submitted in conjunction with this application?	<input type="checkbox"/> YES <input checked="" type="checkbox"/> NO
VI. Responsible Official (RO) Identifying Information	
RO Name Prefix: (<input checked="" type="checkbox"/> Mr. <input type="checkbox"/> Mrs. <input type="checkbox"/> Ms. <input type="checkbox"/> Dr.)	
RO Full Name: Justin Beto	
RO Title: VP of Operations	
Employer Name: Brazos Midstream Operating LLC	
Mailing Address: 777 Main St Suite 3700	
City: Fort Worth	
State: Texas	
ZIP Code: 76102	
Territory:	
Country:	
Foreign Postal Code:	
Internal Mail Code:	
Telephone No.: (817) 332-6800	
Fax No.:	
Email: beto@brazosmidstream.com	

**Federal Operating Permit Program
Site Information Summary
Form OP-1 (Page 3)
Texas Commission on Environmental Quality**

VII. Technical Contact Identifying Information <i>(Complete if different from RO.)</i>
Technical Contact Name Prefix: <input checked="" type="checkbox"/> Mr. <input type="checkbox"/> Mrs. <input type="checkbox"/> Ms. <input type="checkbox"/> Dr.)
Technical Contact Full Name: Gary Mann
Technical Contact Title: Environmental Manager
Employer Name: Brazos Midstream Operating LLC
Mailing Address: 777 Main St. Suite 3700
City: Fort Worth
State: Texas
ZIP Code: 76102
Territory:
Country:
Foreign Postal Code:
Internal Mail Code:
Telephone No.: (682) 429-4839
Fax No.:
Email: mann@brazosmidstream.com
VIII. Reference Only Requirements <i>(For reference only.)</i>
A. State Senator: Senator Cesar Blanco (District 29)
B. State Representative: Representative Andrew S.Murr (D-53)
C. Has the applicant paid emissions fees for the most recent agency fiscal year (Sept. 1 - August 31)? <input checked="" type="checkbox"/> YES <input type="checkbox"/> NO <input type="checkbox"/> N/A
D. Is the site subject to bilingual notice requirements pursuant to 30 TAC § 122.322? <input checked="" type="checkbox"/> YES <input type="checkbox"/> NO
E. Indicate the alternate language(s) in which public notice is required: Spanish

**Federal Operating Permit Program
Site Information Summary
Form OP-1 (Page 4)
Texas Commission on Environmental Quality**

IX. Off-Site Permit Request <i>(Optional for applicants requesting to hold the FOP and records at an off-site location.)</i>
A. Office/Facility Name: Brazos Midstream Operating LLC
B. Physical Address: 777 Main St. Suite 3700
City: Fort Worth
State: Texas
ZIP Code: 76102
Territory:
Country:
Foreign Postal Code:
C. Physical Location:
D. Contact Name Prefix: (<input checked="" type="checkbox"/> Mr. <input type="checkbox"/> Mrs. <input type="checkbox"/> Ms. <input type="checkbox"/> Dr.)
Contact Full Name: Gary Mann
E. Telephone No.: (682) 429-4839
X. Application Area Information
A. Area Name: Comanche Plant
B. Physical Address: 1939 FM-1450
City: Pecos
State: Reeves
ZIP Code: 76722
C. Physical Location: From US 285 S/S Cedar St, drive 3.2 miles and turn left onto FM 1450 E.
Drive 15.1 miles and then turn right; drive 0.8 mile towards the facility location.
D. Nearest City: Pecos
E. State: TX
F. ZIP Code: 76722

**Federal Operating Permit Program
Site Information Summary
Form OP-1 (Page 5)
Texas Commission on Environmental Quality**

X. Application Area Information (continued)
G. Latitude (nearest second): 31 18 47.6
H. Longitude (nearest second): -103 12 33.7
I. Are there any emission units that were not in compliance with the applicable requirements identified in the application at the time of application submittal? <input type="checkbox"/> YES <input checked="" type="checkbox"/> NO
J. Indicate the estimated number of emission units in the application area: ~130 sources including sources covered <input checked="" type="checkbox"/>
K. Are there any emission units in the application area subject to the Acid Rain Program? <input type="checkbox"/> YES <input checked="" type="checkbox"/> NO
XI. Public Notice <i>(Complete this section for SOP Applications and Acid Rain Permit Applications only.)</i>
A. Name of a public place to view application and draft permit: Reeves County Library
B. Physical Address: Reevees 315 S Oak St
City: Pecos
ZIP Code: 79722
C. Contact Person (Someone who will answer questions from the public during the public notice period):
Contact Name Prefix: (<input checked="" type="checkbox"/> Mr. <input type="checkbox"/> Mrs. <input type="checkbox"/> Ms. <input type="checkbox"/> Dr.):
Contact Person Full Name: Gary Mann
Contact Mailing Address: 777 Main St. Suite 3700
City: Fort Worth
State: Texas
ZIP Code: 76102
Territory:
Country:
Foreign Postal Code:
Internal Mail Code:
Telephone No.: 682-429-4839

**Federal Operating Permit Program
Site Information Summary
Form OP-1 (Page 6)
Texas Commission on Environmental Quality**

XII. Delinquent Fees and Penalties
Notice: This form will not be processed until all delinquent fees and/or penalties owed to the TCEQ or the Office of Attorney General on behalf of the TCEQ are paid in accordance with the "Delinquent Fee and Penalty Protocol."
Complete Sections XIII and XIV for Acid Rain Permit and CSAPR applications only. Please include a copy of the Certificate of Representation submitted to EPA.
XIII. Designated Representative (DR) Identifying Information
DR Name Prefix: (<input type="checkbox"/> Mr. <input type="checkbox"/> Mrs. <input type="checkbox"/> Ms. <input type="checkbox"/> Dr.)
DR Full Name:
DR Title:
Employer Name:
Mailing Address:
City:
State:
ZIP Code:
Territory:
Country:
Foreign Postal Code:
Internal Mail Code:
Telephone No.:
Fax No.:
Email:

**Federal Operating Permit Program
Site Information Summary
Form OP-1 (Page 7)
Texas Commission on Environmental Quality**

Complete Sections XIII and XIV for Acid Rain Permit and CSAPR applications only. Please include a copy of the Certificate of Representation submitted to EPA.

XIV. Alternate Designated Representative (ADR) Identifying Information

ADR Name Prefix: (Mr. Mrs. Ms. Dr.)

ADR Full Name:

ADR Title:

Employer Name:

Mailing Address:

City:

State:

ZIP Code:

Territory:

Country:

Foreign Postal Code:

Internal Mail Code:

Telephone No.:

Fax No.:

Email:

FORM OP-2

APPLICATION FOR PERMIT REVISION/PERMIT RENEWAL

**Federal Operating Permit Program
Application for Permit Revision/Renewal
Form OP-2-Table 1
Texas Commission on Environmental Quality**

Date: 09/03/2024
Permit No.: 4119
Regulated Entity No.: RN109161745
Company Name: Comanche Plant
For Submissions to EPA
Has an electronic copy of this application been submitted (or is being submitted) to EPA? <input checked="" type="checkbox"/> YES <input type="checkbox"/> NO
I. Application Type
Indicate the type of application:
<input checked="" type="checkbox"/> Renewal
<input checked="" type="checkbox"/> Streamlined Revision (Must include provisional terms and conditions as explained in the instructions.)
<input type="checkbox"/> Significant Revision
<input type="checkbox"/> Revision Requesting Prior Approval
<input type="checkbox"/> Administrative Revision
<input type="checkbox"/> Response to Reopening
II. Qualification Statement
For SOP Revisions Only <input checked="" type="checkbox"/> YES <input type="checkbox"/> NO
For GOP Revisions Only <input type="checkbox"/> YES <input type="checkbox"/> NO

**Federal Operating Permit Program
Application for Permit Revision/Renewal
Form OP-2-Table 1 (continued)
Texas Commission on Environmental Quality**

III. Major Source Pollutants (Complete this section if the permit revision is due to a change at the site or change in regulations.)
Indicate all pollutants for which the site is a major source based on the site's potential to emit: (Check the appropriate box(es).)
<input checked="" type="checkbox"/> VOC <input checked="" type="checkbox"/> NO _x <input checked="" type="checkbox"/> SO ₂ <input type="checkbox"/> PM ₁₀ <input checked="" type="checkbox"/> CO <input type="checkbox"/> Pb <input type="checkbox"/> HAP
Other:
IV. Reference Only Requirements (For reference only)
Has the applicant paid emissions fees for the most recent agency fiscal year (September 1 - August 31)? <input checked="" type="checkbox"/> YES <input type="checkbox"/> NO <input type="checkbox"/> N/A
V. Delinquent Fees and Penalties
Notice: This form will not be processed until all delinquent fees and/or penalties owed to the TCEQ or the Office of the Attorney General on behalf of the TCEQ are paid in accordance with the Delinquent Fee and penalty protocol.

**Federal Operating Permit Program
Application for Permit Revision/Renewal
Form OP-2-Table 2
Texas Commission on Environmental Quality**

Date: 09/03/2024
Permit No.: 4119
Regulated Entity No.: RN109161745
Company Name: Brazos Midstream Operating LLC

Using the table below, provide a description of the revision.

Revision No.	Revision Code	New Unit	Unit/Group	Process		NSR Authorization	Description of Change and Provisional Terms and Conditions
				ID No.	Applicable Form		
1	MS-C	NO	CR-2209	OP-UA2	OP-UA2	140834	The unit has been removed from the site
2	MS-C	NO	CR-2210	OP-UA2	OP-UA2	140834	The unit has been removed from the site
3	MS-C	NO	CR-2211	OP-UA2	OP-UA2	140834	The unit has been removed from the site.
4	MS-C	NO	LOAD3-CONDENSATE	OP-UA1	OP-UA1	140834	This emission point does not exist any longer.

**Federal Operating Permit Program
Application for Permit Revision/Renewal
Form OP-2-Table 3
Texas Commission on Environmental Quality**

Date: 9/03/2024
Permit No.: 4119
Regulated Entity No.: RN109161745
Company Name: Brazos Midstream Operating LLC
I. Significant Revision <i>(Complete this section if you are submitting a significant revision application or a renewal application that includes a significant revision.)</i>
A. Is the site subject to bilingual requirements pursuant to 30 TAC § 122.322? <input type="checkbox"/> YES <input type="checkbox"/> NO
B. Indicate the alternate language(s) in which public notice is required:
C. Will, there be a change in air pollutant emissions as a result of the significant revision? <input type="checkbox"/> YES <input type="checkbox"/> NO

**FORM OP-CRO1
CERTIFICATION BY RESPONSIBLE OFFICIAL**

**Form OP-CRO1
Certification by Responsible Official
Federal Operating Permit Program**

All initial permit application, revision, renewal, and reopening submittals requiring certification must be addressed using this form. Updates to site operating permit (SOP) and temporary operating permit (TOP) applications, other than public notice verification materials, must be certified prior to authorization of public notice or start of public announcement. Updates to general operating permit (GOP) applications must be certified prior to receiving an authorization to operate under a GOP.

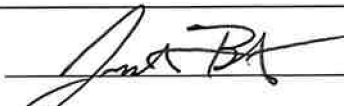
I. Identifying Information		
RN: RN109161745	CN:CN605077106	Account No.: RFA032E
Permit No.:4119	Project No.:	
Area Name: Comanche Plant	Company Name: Brazos Midstream Operating LLC	
II. Certification Type <i>(Please mark the appropriate box)</i>		
<input type="checkbox"/> Responsible Official	<input checked="" type="checkbox"/> Duly Authorized Representative	
III. Submittal Type <i>(Please mark the appropriate box) (Only one response can be accepted per form)</i>		
<input type="checkbox"/> SOP/TOP Initial Permit Application	<input type="checkbox"/> Update to Permit Application	
<input type="checkbox"/> GOP Initial Permit Application	<input checked="" type="checkbox"/> Permit Revision, Renewal, or Reopening	
<input type="checkbox"/> Other: _____		
IV. Certification of Truth		
<p>This certification does not extend to information which is designated by the TCEQ as information for reference only.</p> <p>I, <u>Justin Beto</u> _____ certify that I am the RO _____ <i>(Certifier Name printed or typed)</i> <i>(RO or DAR)</i></p> <p>and that, based on information and belief formed after reasonable inquiry, the statements and information dated during the time period or on the specific date(s) below, are true, accurate, and complete:</p> <p><i>Note: Enter Either a Time Period OR Specific Date(s) for each certification. This section must be completed. The certification is not valid without documentation date(s).</i></p> <p>Time Period: From _____ to _____ <i>Start Date</i> <i>End Date</i></p> <p>Specific Dates: <u>09/03/2024</u> _____ <i>Date 1</i> <i>Date 2</i> <i>Date 3</i> <i>Date 4</i> <i>Date 5</i> <i>Date 6</i></p>		
Signature: <u></u>	Signature Date: <u>10-9-24</u>	
Title: <u>VP of Operations</u>		

FORM OP-REQ1

**APPLICATION AREA-WIDE APPLICABILITY DETERMINATIONS
AND GENERAL INFORMATION**

Texas Commission on Environmental Quality
Application Area-Wide Applicability Determinations and General Information
Form OP-REQ1
Federal Operating Permit Program

Date:	09/03/2024
Permit No.:	4119
RN No.:	RN109161745

For SOP applications, answer ALL questions unless otherwise directed.

◆ *For GOP applications, answer ONLY these questions unless otherwise directed.*

Form OP-REQ1: Page 1		
I. Title 30 TAC Chapter 111 - Control of Air Pollution from Visible Emissions and Particulate Matter		
A. Visible Emissions		
◆	1. The application area includes stationary vents constructed on or before January 31, 1972.	<input type="checkbox"/> YES <input checked="" type="checkbox"/> NO
◆	2. The application area includes stationary vents constructed after January 31, 1972. <i>If the responses to Questions I.A.1 and I.A.2 are both "NO," go to Question I.A.6. If the response to Question I.A.1 is "NO" and the response to Question I.A.2 is "YES," go to Question I.A.4.</i>	<input checked="" type="checkbox"/> YES <input type="checkbox"/> NO
◆	3. The application area is opting to comply with the requirements for stationary vents constructed after January 31, 1972 for vents in the application area constructed on or before January 31, 1972.	<input type="checkbox"/> YES <input type="checkbox"/> NO
◆	4. All stationary vents are addressed on a unit specific basis.	<input type="checkbox"/> YES <input checked="" type="checkbox"/> NO
◆	5. Test Method 9 (40 CFR Part 60, Appendix A, Method 9 - Visual Determination of the Opacity of Emissions from Stationary Sources) is used to determine opacity of emissions in the application area.	<input checked="" type="checkbox"/> YES <input type="checkbox"/> NO
◆	6. The application area includes structures subject to 30 TAC § 111.111(a)(7)(A).	<input type="checkbox"/> YES <input checked="" type="checkbox"/> NO
◆	7. The application area includes sources, other than those specified in 30 TAC § 111.111(a)(1), (4), or (7), subject to 30 TAC § 111.111(a)(8)(A).	<input checked="" type="checkbox"/> YES <input type="checkbox"/> NO
◆	8. Emissions from units in the application area include contributions from uncombined water.	<input type="checkbox"/> YES <input checked="" type="checkbox"/> NO
◆	9. The application area is located in the City of El Paso, including Fort Bliss Military Reservation, and includes solid fuel heating devices subject to 30 TAC § 111.111(c).	<input type="checkbox"/> YES <input checked="" type="checkbox"/> NO <input type="checkbox"/> N/A

Texas Commission on Environmental Quality
Application Area-Wide Applicability Determinations and General Information
Form OP-REQ1
Federal Operating Permit Program

Date:	09/03/2024
Permit No.:	4119
RN No.:	RN109161745

For SOP applications, answer ALL questions unless otherwise directed.

◆ *For GOP applications, answer ONLY these questions unless otherwise directed.*

Form OP-REQ1: Page 2	
I. Title 30 TAC Chapter 111 - Control of Air Pollution from Visible Emissions and Particulate Matter (continued)	
B. Materials Handling, Construction, Roads, Streets, Alleys, and Parking Lots	
1. Items a - d determines applicability of any of these requirements based on geographical location.	
◆ a. The application area is located within the City of El Paso.	<input type="checkbox"/> YES <input checked="" type="checkbox"/> NO
◆ b. The application area is located within the Fort Bliss Military Reservation, except areas specified in 30 TAC § 111.141.	<input type="checkbox"/> YES <input checked="" type="checkbox"/> NO
◆ c. The application area is located in the portion of Harris County inside the loop formed by Beltway 8.	<input type="checkbox"/> YES <input checked="" type="checkbox"/> NO
◆ d. The application area is located in the area of Nueces County outlined in Group II state implementation plan (SIP) for inhalable particulate matter adopted by the TCEQ on May 13, 1988.	<input type="checkbox"/> YES <input checked="" type="checkbox"/> NO
<i>If there is any "YES" response to Questions I.B.1.a - d, answers Questions I.B.2.a - d. If all responses to Questions I.B.1.a-d are "NO," go to Section I.C.</i>	
2. Items a - d determine the specific applicability of these requirements.	
◆ a. The application area is subject to 30 TAC § 111.143.	<input type="checkbox"/> YES <input type="checkbox"/> NO
◆ b. The application area is subject to 30 TAC § 111.145.	<input type="checkbox"/> YES <input type="checkbox"/> NO
◆ c. The application area is subject to 30 TAC § 111.147.	<input type="checkbox"/> YES <input type="checkbox"/> NO
◆ d. The application area is subject to 30 TAC § 111.149.	<input type="checkbox"/> YES <input type="checkbox"/> NO
C. Emissions Limits on Nonagricultural Processes	
◆ 1. The application area includes a nonagricultural process subject to 30 TAC § 111.151.	<input type="checkbox"/> YES <input checked="" type="checkbox"/> NO
2. The application area includes a vent from a nonagricultural process that is subject to additional monitoring requirements. <i>If the response to Question I.C.2 is "NO," go to Question I.C.4.</i>	<input type="checkbox"/> YES <input checked="" type="checkbox"/> NO
3. All vents from nonagricultural process in the application area are subject to additional monitoring requirements.	<input type="checkbox"/> YES <input type="checkbox"/> NO

Texas Commission on Environmental Quality
Application Area-Wide Applicability Determinations and General Information
Form OP-REQ1
Federal Operating Permit Program

Date:	09/03/2024
Permit No.:	4119
RN No.:	RN109161745

For SOP applications, answer ALL questions unless otherwise directed.

◆ *For GOP applications, answer ONLY these questions unless otherwise directed.*

Form OP-REQ1: Page 3	
I. Title 30 TAC Chapter 111 - Control of Air Pollution from Visible Emissions and Particulate Matter (continued)	
C. Emissions Limits on Nonagricultural Processes (continued)	
4. The application area includes oil or gas fuel-fired steam generators subject to 30 TAC §§ 111.153(a) and 111.153(c).	<input type="checkbox"/> YES <input checked="" type="checkbox"/> NO
5. The application area includes oil or gas fuel-fired steam generators that are subject to additional monitoring requirements. <i>If the response to Question I.C.5 is "NO," go to Question I.C.7.</i>	<input type="checkbox"/> YES <input checked="" type="checkbox"/> NO
6. All oil or gas fuel-fired steam generators in the application area are subject to additional monitoring requirements.	<input type="checkbox"/> YES <input type="checkbox"/> NO
7. The application area includes solid fossil fuel-fired steam generators subject to 30 TAC §§ 111.153(a) and 111.153(b).	<input type="checkbox"/> YES <input checked="" type="checkbox"/> NO
8. The application area includes solid fossil fuel-fired steam generators that are subject to additional monitoring requirements. <i>If the response to Question I.C.8 is "NO," go to Section I.D.</i>	<input type="checkbox"/> YES <input checked="" type="checkbox"/> NO
9. All solid fossil fuel-fired steam generators in the application area are subject to additional monitoring requirements.	<input type="checkbox"/> YES <input type="checkbox"/> NO
D. Emissions Limits on Agricultural Processes	
1. The application area includes agricultural processes subject to 30 TAC § 111.171.	<input type="checkbox"/> YES <input checked="" type="checkbox"/> NO
E. Outdoor Burning	
◆ 1. Outdoor burning is conducted in the application area. <i>If the response to Question I.E.1 is "NO," go to Section II.</i>	<input type="checkbox"/> YES <input checked="" type="checkbox"/> NO
◆ 2. Fire training is conducted in the application area and subject to the exception provided in 30 TAC § 111.205.	<input type="checkbox"/> YES <input type="checkbox"/> NO
◆ 3. Fires for recreation, ceremony, cooking, and warmth are used in the application area and subject to the exception provided in 30 TAC § 111.207.	<input type="checkbox"/> YES <input type="checkbox"/> NO
◆ 4. Disposal fires are used in the application area and subject to the exception provided in 30 TAC § 111.209.	<input type="checkbox"/> YES <input type="checkbox"/> NO

Texas Commission on Environmental Quality
Application Area-Wide Applicability Determinations and General Information
Form OP-REQ1
Federal Operating Permit Program

Date:	09/03/2024
Permit No.:	4119
RN No.:	RN109161745

For SOP applications, answer ALL questions unless otherwise directed.

◆ *For GOP applications, answer ONLY these questions unless otherwise directed.*

Form OP-REQ1: Page 4	
I. Title 30 TAC Chapter 111 - Control of Air Pollution from Visible Emissions and Particulate Matter (continued)	
E. Outdoor Burning (continued)	
◆ 5. Prescribed burning is used in the application area and subject to the exception provided in 30 TAC § 111.211.	<input type="checkbox"/> YES <input type="checkbox"/> NO
◆ 6. Hydrocarbon burning is used in the application area and subject to the exception provided in 30 TAC § 111.213.	<input type="checkbox"/> YES <input type="checkbox"/> NO
◆ 7. The application area has received the TCEQ Executive Director approval of otherwise prohibited outdoor burning according to 30 TAC § 111.215.	<input type="checkbox"/> YES <input type="checkbox"/> NO
II. Title 30 TAC Chapter 112 - Control of Air Pollution from Sulfur Compounds	
A. Temporary Fuel Shortage Plan Requirements	
1. The application area includes units that are potentially subject to the temporary fuel shortage plan requirements of 30 TAC §§ 112.15 - 112.18.	<input type="checkbox"/> YES <input checked="" type="checkbox"/> NO
III. Title 30 TAC Chapter 115 - Control of Air Pollution from Volatile Organic Compounds	
A. Applicability	
◆ 1. The application area is located in the Houston/Galveston/Brazoria area, Beaumont/Port Arthur area, Dallas/Fort Worth area, El Paso area, or a covered attainment county as defined by 30 TAC § 115.10. <i>See instructions for inclusive counties. If the response to Question III.A.1 is "NO," go to Section IV.</i>	<input type="checkbox"/> YES <input checked="" type="checkbox"/> NO
B. Storage of Volatile Organic Compounds	
◆ 1. The application area includes storage tanks, reservoirs, or other containers capable of maintaining working pressure sufficient at all times to prevent any VOC vapor or gas loss to the atmosphere.	<input type="checkbox"/> YES <input type="checkbox"/> NO

Texas Commission on Environmental Quality
Application Area-Wide Applicability Determinations and General Information
Form OP-REQ1
Federal Operating Permit Program

Date:	09/03/2024
Permit No.:	4119
RN No.:	RN109161745

For SOP applications, answer ALL questions unless otherwise directed.

◆ *For GOP applications, answer ONLY these questions unless otherwise directed.*

Form OP-REQ1: Page 5	
III. Title 30 TAC Chapter 115 - Control of Air Pollution from Volatile Organic Compounds (continued)	
C. Industrial Wastewater	
1. The application area includes affected VOC wastewater streams of an affected source category, as defined in 30 TAC § 115.140. <i>If the response to Question III.C.1 is "NO" or "N/A," go to Section III.D.</i>	<input type="checkbox"/> YES <input type="checkbox"/> NO <input type="checkbox"/> N/A
2. The application area is located at a petroleum refinery in the Beaumont/Port Arthur or Houston/Galveston/Brazoria area. <i>If the response to Question III.C.2 is "YES" and the refinery is in the Beaumont/Port Arthur area, go to Section III.D.</i>	<input type="checkbox"/> YES <input type="checkbox"/> NO
3. The application area is complying with the provisions of 40 CFR Part 63, Subpart G, as an alternative to complying with this division (relating to Industrial Wastewater). <i>If the response to Question III.C.3 is "YES," go to Section III.D.</i>	<input type="checkbox"/> YES <input type="checkbox"/> NO
4. The application area is located at a plant with an annual VOC loading in wastewater, as determined in accordance with 30 TAC § 115.148, less than or equal to 10 Mg (11.03 tons). <i>If the response to Question III.C.4 is "YES," go to Section III.D.</i>	<input type="checkbox"/> YES <input type="checkbox"/> NO
5. The application area includes wastewater drains, junction boxes, lift stations, or weirs that are subject to the control requirements of 30 TAC § 115.142(1).	<input type="checkbox"/> YES <input type="checkbox"/> NO
6. The application area includes wastewater drains, junction boxes, lift stations, or weirs that handle streams chosen for exemption under 30 TAC § 115.147(2).	<input type="checkbox"/> YES <input type="checkbox"/> NO
7. The application area includes wastewater drains, junction boxes, lift stations, or weirs that have an executive director approved exemption under 30 TAC § 115.147(4).	<input type="checkbox"/> YES <input type="checkbox"/> NO
D. Loading and Unloading of VOCs	
◆ 1. The application area includes VOC loading operations.	<input type="checkbox"/> YES <input type="checkbox"/> NO
◆ 2. The application area includes VOC transport vessel unloading operations. <i>For GOP applications, if the responses to Questions III.D.1 - D.2 are "NO," go to Section III.E.</i>	<input type="checkbox"/> YES <input type="checkbox"/> NO

Texas Commission on Environmental Quality
Application Area-Wide Applicability Determinations and General Information
Form OP-REQ1
Federal Operating Permit Program

Date:	09/03/2024
Permit No.:	4119
RN No.:	RN109161745

For SOP applications, answer ALL questions unless otherwise directed.

◆ *For GOP applications, answer ONLY these questions unless otherwise directed.*

Form OP-REQ1: Page 6	
III. Title 30 TAC Chapter 115 - Control of Air Pollution from Volatile Organic Compounds (continued)	
D. Loading and Unloading of VOCs (continued)	
◆ 3. Transfer operations at motor vehicle fuel dispensing facilities are the only VOC transfer operations conducted in the application area.	<input type="checkbox"/> YES <input type="checkbox"/> NO
E. Filling of Gasoline Storage Vessels (Stage I) for Motor Vehicle Fuel Dispensing Facilities	
◆ 1. The application area includes one or more motor vehicle fuel dispensing facilities and gasoline is transferred from a tank-truck tank into a stationary storage container. <i>If the response to Question III.E.1 is "NO," go to Section III.F.</i>	<input type="checkbox"/> YES <input type="checkbox"/> NO
◆ 2. Transfers to stationary storage containers used exclusively for the fueling of agricultural implements are the only transfer operations conducted at facilities in the application area.	<input type="checkbox"/> YES <input type="checkbox"/> NO
◆ 3. All transfers at facilities in the application area are made into stationary storage containers with internal floating roofs, external floating roofs, or their equivalent. <i>If the response to Question III.E.2 and/or E.3 is "YES," go to Section III.F.</i>	<input type="checkbox"/> YES <input type="checkbox"/> NO
◆ 4. The application area is located in a covered attainment county as defined in 30 TAC § 115.10. <i>If the response to Question III.E.4 is "NO," go to Question III.E.9.</i>	<input type="checkbox"/> YES <input type="checkbox"/> NO
◆ 5. Stationary gasoline storage containers with a nominal capacity less than or equal to 1,000 gallons are located at the facility.	<input type="checkbox"/> YES <input type="checkbox"/> NO
◆ 6. Stationary gasoline storage containers with a nominal capacity greater than 1,000 gallons are located at the facility.	<input type="checkbox"/> YES <input type="checkbox"/> NO
◆ 7. At facilities located in covered attainment counties other than Bastrop, Bexar, Caldwell, Comal, Guadalupe, Hays, Travis, Williamson, or Wilson County, transfers are made to stationary storage tanks greater than 1000 gallons located at a facility which has dispensed less than 100,000 gallons of gasoline in a calendar month after October 31, 2014. <i>If the response to Question III.E.7 is "YES," go to Section III.F.</i>	<input type="checkbox"/> YES <input type="checkbox"/> NO

Texas Commission on Environmental Quality
Application Area-Wide Applicability Determinations and General Information
Form OP-REQ1
Federal Operating Permit Program

Date:	09/03/2024
Permit No.:	4119
RN No.:	RN109161745

For SOP applications, answer ALL questions unless otherwise directed.

◆ *For GOP applications, answer ONLY these questions unless otherwise directed.*

Form OP-REQ1: Page 7		
III. Title 30 TAC Chapter 115 - Control of Air Pollution from Volatile Organic Compounds (continued)		
E. Filling of Gasoline Storage Vessels (Stage I) for Motor Vehicle Fuel Dispensing Facilities (continued)		
◆	8. At facilities located in Bastrop, Bexar, Caldwell, Comal, Guadalupe, Hays, Travis, Williamson, or Wilson County, transfers are made to stationary storage tanks greater than 1000 gallons located at a facility which has dispensed no more than 25,000 gallons of gasoline in a calendar month after December 31, 2004. <i>If the response to Question III.E.8 is "YES," go to Section III.F.</i>	<input type="checkbox"/> YES <input type="checkbox"/> NO
◆	9. Transfers are made to stationary storage tanks located at a motor vehicle fuel dispensing facility which has dispensed no more than 10,000 gallons of gasoline in any calendar month after January 1, 1991 and for which construction began prior to November 15, 1992.	<input type="checkbox"/> YES <input type="checkbox"/> NO
◆	10. Transfers are made to stationary storage tanks located at a motor vehicle fuel dispensing facility which has dispensed more than 10,000 gallons of gasoline in any calendar month after January 1, 1991 and for which construction began prior to November 15, 1992.	<input type="checkbox"/> YES <input type="checkbox"/> NO
◆	11. Transfers are made to stationary storage tanks located at a motor vehicle fuel dispensing facility which commenced construction on or after November 15, 1992.	<input type="checkbox"/> YES <input type="checkbox"/> NO
◆	12. At facilities located in Ellis, Johnson, Kaufman, Parker, or Rockwall County, transfers are made to stationary storage tanks located at a facility which has dispensed at least 10,000 gallons of gasoline but less than 125,000 gallons of gasoline in a calendar month after April 30, 2005.	<input type="checkbox"/> YES <input type="checkbox"/> NO
F. Control of VOC Leaks from Transport Vessels (Complete this section for GOP applications for GOPs 511, 512, 513 and 514 only)		
◆	1. Tank-truck tanks are filled with, or emptied of, gasoline at a facility that is subject to 30 TAC § 115.214(a)(1)(C) or 115.224(2) within the application area.	<input type="checkbox"/> YES <input type="checkbox"/> NO <input type="checkbox"/> N/A

Texas Commission on Environmental Quality
Application Area-Wide Applicability Determinations and General Information
Form OP-REQ1
Federal Operating Permit Program

Date:	09/03/2024
Permit No.:	4119
RN No.:	RN109161745

For SOP applications, answer ALL questions unless otherwise directed.

◆ *For GOP applications, answer ONLY these questions unless otherwise directed.*

Form OP-REQ1: Page 8	
III. Title 30 TAC Chapter 115 - Control of Air Pollution from Volatile Organic Compounds (continued)	
F. Control of VOC Leaks from Transport Vessels (Complete this section for GOP applications for GOPs 511, 512, 513 and 514 only) (continued)	
◆ 2. Tank-truck tanks are filled with non-gasoline VOCs having a TVP greater than or equal to 0.5 psia under actual storage conditions at a facility subject to 30 TAC § 115.214(a)(1)(C) within the application area.	<input type="checkbox"/> YES <input type="checkbox"/> NO <input type="checkbox"/> N/A
◆ 3. Tank-truck tanks are filled with, or emptied of, gasoline at a facility that is subject to 30 TAC § 115.214(b)(1)(C) or 115.224(2) within the application area.	<input type="checkbox"/> YES <input type="checkbox"/> NO <input type="checkbox"/> N/A
G. Control of Vehicle Refueling Emissions (Stage II) at Motor Vehicle Fuel Dispensing Facilities	
◆ 1. The application area includes one or more motor vehicle fuel dispensing facilities and gasoline is transferred from a stationary storage container into motor vehicle fuel tanks. <i>If the response to Question III.G.1 is "NO" or "N/A," go to Section III.H.</i>	<input type="checkbox"/> YES <input type="checkbox"/> NO <input type="checkbox"/> N/A
◆ 2. The application area includes facilities that began construction on or after November 15, 1992 and prior to May 16, 2012.	<input type="checkbox"/> YES <input type="checkbox"/> NO
◆ 3. The application area includes facilities that began construction prior to November 15, 1992. <i>If the responses to Questions III.G.2 and Question III.G.3 are both "NO," go to Section III.H.</i>	<input type="checkbox"/> YES <input type="checkbox"/> NO
◆ 4. The application area includes only facilities that have a monthly throughput of less than 10,000 gallons of gasoline.	<input type="checkbox"/> YES <input type="checkbox"/> NO
◆ 5. The decommissioning of all Stage II vapor recovery control equipment located in the application area has been completed and the decommissioning notice submitted.	<input type="checkbox"/> YES <input type="checkbox"/> NO <input type="checkbox"/> N/A

Texas Commission on Environmental Quality
Application Area-Wide Applicability Determinations and General Information
Form OP-REQ1
Federal Operating Permit Program

Date:	09/03/2024
Permit No.:	4119
RN No.:	RN109161745

For SOP applications, answer ALL questions unless otherwise directed.

◆ *For GOP applications, answer ONLY these questions unless otherwise directed.*

Form OP-REQ1: Page 9	
III. Title 30 TAC Chapter 115 - Control of Air Pollution from Volatile Organic Compounds (continued)	
H. Control Of Reid Vapor Pressure (RVP) of Gasoline	
◆ 1. The application area includes stationary tanks, reservoirs, or other containers holding gasoline that may ultimately be used in a motor vehicle in El Paso County. <i>If the response to Question III.H.1 is "NO" or "N/A," go to Section III.I.</i>	<input type="checkbox"/> YES <input type="checkbox"/> NO <input type="checkbox"/> N/A
◆ 2. The application area includes stationary tanks, reservoirs, or other containers holding gasoline that will be used exclusively for the fueling of agricultural implements.	<input type="checkbox"/> YES <input type="checkbox"/> NO
◆ 3. The application area includes a motor vehicle fuel dispensing facility.	<input type="checkbox"/> YES <input type="checkbox"/> NO
◆ 4. The application area includes stationary tanks, reservoirs, or other containers holding gasoline and having a nominal capacity of 500 gallons or less.	<input type="checkbox"/> YES <input type="checkbox"/> NO
I. Process Unit Turnaround and Vacuum-Producing Systems in Petroleum Refineries	
1. The application area is located at a petroleum refinery.	<input type="checkbox"/> YES <input type="checkbox"/> NO
J. Surface Coating Processes (Complete this section for GOP applications only.)	
◆ 1. Surface coating operations (other than those performed on equipment located on-site and in-place) that meet the exemption specified in 30 TAC § 115.427(3)(A) or 115.427(7) are performed in the application area.	<input type="checkbox"/> YES <input type="checkbox"/> NO <input type="checkbox"/> N/A

Texas Commission on Environmental Quality
Application Area-Wide Applicability Determinations and General Information
Form OP-REQ1
Federal Operating Permit Program

Date:	09/03/2024
Permit No.:	4119
RN No.:	RN109161745

For SOP applications, answer ALL questions unless otherwise directed.

◆ *For GOP applications, answer ONLY these questions unless otherwise directed.*

Form OP-REQ1: Page 10	
III. Title 30 TAC Chapter 115 - Control of Air Pollution from Volatile Organic Compounds (continued)	
K. Cutback Asphalt	
1. Conventional cutback asphalt containing VOC solvents for the paving of roadways, driveways, or parking lots, is used or specified for use in the application area by a state, municipal, or county agency. <i>If the response to Question III.K.1 is "N/A," go to Section III.L.</i>	<input type="checkbox"/> YES <input type="checkbox"/> NO <input type="checkbox"/> N/A
2. The use, application, sale, or offering for sale of conventional cutback asphalt containing VOC solvents for the paving of roadways, driveways, or parking lots occurs in the application area.	<input type="checkbox"/> YES <input type="checkbox"/> NO <input type="checkbox"/> N/A
3. Asphalt emulsion is used or produced within the application area.	<input type="checkbox"/> YES <input type="checkbox"/> NO
4. The application area is using an alternate control requirement as specified in 30 TAC § 115.513. <i>If the response to Question III.K.4 is "NO," go to Section III.L.</i>	<input type="checkbox"/> YES <input type="checkbox"/> NO
5. The application area uses, applies, sells, or offers for sale asphalt concrete, made with cutback asphalt, that meets the exemption specified in 30 TAC § 115.517(1).	<input type="checkbox"/> YES <input type="checkbox"/> NO
6. The application area uses, applies, sells, or offers for sale cutback asphalt that is used solely as a penetrating prime coat.	<input type="checkbox"/> YES <input type="checkbox"/> NO
7. The applicant using cutback asphalt is a state, municipal, or county agency.	<input type="checkbox"/> YES <input type="checkbox"/> NO
L. Degassing of Storage Tanks, Transport Vessels and Marine Vessels	
◆ 1. The application area includes degassing operations for stationary, marine, and/or transport vessels. <i>If the response to Question III.L.1 is "NO" or "N/A," go to Section III.M.</i>	<input type="checkbox"/> YES <input type="checkbox"/> NO <input type="checkbox"/> N/A
◆ 2. Degassing of only ocean-going, self-propelled VOC marine vessels is performed in the application area. <i>If the response to Question III.L.2 is "YES," go to Section III.M.</i>	<input type="checkbox"/> YES <input type="checkbox"/> NO <input type="checkbox"/> N/A

Texas Commission on Environmental Quality
Application Area-Wide Applicability Determinations and General Information
Form OP-REQ1
Federal Operating Permit Program

Date:	09/03/2024
Permit No.:	4119
RN No.:	RN109161745

For SOP applications, answer ALL questions unless otherwise directed.

◆ *For GOP applications, answer ONLY these questions unless otherwise directed.*

Form OP-REQ1: Page 11		
III. Title 30 TAC Chapter 115 - Control of Air Pollution from Volatile Organic Compounds (continued)		
L. Degassing of Storage Tanks, Transport Vessels and Marine Vessels (continued)		
◆	3. Degassing of stationary VOC storage vessels with a nominal storage capacity of 1,000,000 gallons or more and a vapor space partial pressure greater than or equal to 0.5 psia of VOC is performed in the application area.	<input type="checkbox"/> YES <input type="checkbox"/> NO <input type="checkbox"/> N/A
◆	4. Degassing of stationary VOC storage vessels with a nominal storage capacity of 250,000 gallons or more, or a nominal storage capacity of 75,000 gallons and storing materials with a true vapor pressure greater than 2.6 psia, and a vapor space partial pressure greater than or equal to 0.5 psia of VOC is performed in the application area.	<input type="checkbox"/> YES <input type="checkbox"/> NO <input type="checkbox"/> N/A
◆	5. Degassing of VOC transport vessels with a nominal storage capacity of 8,000 gallons or more and a vapor space partial pressure greater than or equal to 0.5 psia of VOC is performed in the application area.	<input type="checkbox"/> YES <input type="checkbox"/> NO
◆	6. Degassing of VOC marine vessels with a nominal storage capacity of 10,000 barrels (420,000 gallons) or more and a vapor space partial pressure greater than or equal to 0.5 psia of VOC is performed in the application area.	<input type="checkbox"/> YES <input type="checkbox"/> NO <input type="checkbox"/> N/A
◆	7. Degassing of VOC marine vessels with a nominal storage capacity of 10,000 barrels (420,000 gallons) and a vapor space partial pressure \geq 0.5 psia that have sustained damage as specified in 30 TAC § 115.547(5) is performed in the application area.	<input type="checkbox"/> YES <input type="checkbox"/> NO <input type="checkbox"/> N/A
M. Petroleum Dry Cleaning Systems		
	1. The application area contains one or more petroleum dry cleaning facilities that use petroleum based solvents.	<input type="checkbox"/> YES <input type="checkbox"/> NO <input type="checkbox"/> N/A

Texas Commission on Environmental Quality
Application Area-Wide Applicability Determinations and General Information
Form OP-REQ1
Federal Operating Permit Program

Date:	09/03/2024
Permit No.:	4119
RN No.:	RN109161745

For SOP applications, answer ALL questions unless otherwise directed.

◆ *For GOP applications, answer ONLY these questions unless otherwise directed.*

Form OP-REQ1: Page 12	
III. Title 30 TAC Chapter 115 - Control of Air Pollution from Volatile Organic Compounds (continued)	
N. Vent Gas Control (Highly-reactive volatile organic compounds (HRVOC))	
1. The application area includes one or more vent gas streams containing HRVOC.	<input type="checkbox"/> YES <input type="checkbox"/> NO <input type="checkbox"/> N/A
2. The application area includes one or more flares that emit or have the potential to emit HRVOC. <i>If the responses to Questions III.N.1 and III.N.2 are both "NO" or "N/A," go to Section III.O. If the response to Question III.N.1 is "YES," continue with Question III.N.3.</i>	<input type="checkbox"/> YES <input type="checkbox"/> NO <input type="checkbox"/> N/A
3. All vent streams in the application area that are routed to a flare contain less than 5.0% HRVOC by weight at all times.	<input type="checkbox"/> YES <input type="checkbox"/> NO
4. All vent streams in the application area that are not routed to a flare contain less than 100 ppmv HRVOC at all times. <i>If the responses to Questions III.N.3 and III.N.4 are both "NO," go to Section III.O.</i>	<input type="checkbox"/> YES <input type="checkbox"/> NO
5. The application area contains pressure relief valves that are not controlled by a flare.	<input type="checkbox"/> YES <input type="checkbox"/> NO
6. The application area has at least one vent stream which has no potential to emit HRVOC.	<input type="checkbox"/> YES <input type="checkbox"/> NO
7. The application area has vent streams from a source described in 30 TAC § 115.727(c)(3)(A) - (H).	<input type="checkbox"/> YES <input type="checkbox"/> NO
O. Cooling Tower Heat Exchange Systems (HRVOC)	
1. The application area includes one or more cooling tower heat exchange systems that emit or have the potential to emit HRVOC.	<input type="checkbox"/> YES <input type="checkbox"/> NO <input type="checkbox"/> N/A

Texas Commission on Environmental Quality
Application Area-Wide Applicability Determinations and General Information
Form OP-REQ1
Federal Operating Permit Program

Date:	09/03/2024
Permit No.:	4119
RN No.:	RN109161745

For SOP applications, answer ALL questions unless otherwise directed.

◆ *For GOP applications, answer ONLY these questions unless otherwise directed.*

Form OP-REQ1: Page 13	
IV. Title 30 TAC Chapter 117 - Control of Air Pollution from Nitrogen Compounds	
A. Applicability	
◆ 1. The application area is located in the Houston/Galveston/Brazoria, Beaumont/Port Arthur, or Dallas/Fort Worth Eight-Hour area. <i>For SOP applications, if the response to Question IV.A.1 is "YES," complete Sections IV.B - IV.F and IV.H. For GOP applications for GOPs 511, 512, 513, or 514, if the response to Question IV.A.1 is "YES," go to Section IV.F. For GOP applications for GOP 517, if the response to Question IV.A.1 is "YES," complete Sections IV.C and IV.F. For GOP applications, if the response to Question IV.A.1 is "NO," go to Section VI.</i>	<input type="checkbox"/> YES <input checked="" type="checkbox"/> NO
2. The application area is located in Bexar, Comal, Ellis, Hays, or McLennan County and includes a cement kiln. <i>If the response to Question IV.A.2 is "YES," go to Question IV.H.1.</i>	<input type="checkbox"/> YES <input checked="" type="checkbox"/> NO
3. The application area includes a utility electric generator in an east or central Texas county. <i>See instructions for a list of counties included. If the response to Question IV.A.3 is "YES," go to Question IV.G.1. If the responses to Questions IV.A.1 - 3 are all "NO," go to Question IV.H.1.</i>	<input type="checkbox"/> YES <input checked="" type="checkbox"/> NO
B. Utility Electric Generation in Ozone Nonattainment Areas	
1. The application area includes units specified in 30 TAC §§ 117.1000, 117.1200, or 117.1300. <i>If the response to Question IV.B.1 is "NO," go to Question IV.C.1.</i>	<input type="checkbox"/> YES <input type="checkbox"/> NO
2. The application area is complying with a System Cap in 30 TAC §§ 117.1020 or 117.1220.	<input type="checkbox"/> YES <input type="checkbox"/> NO

Texas Commission on Environmental Quality
Application Area-Wide Applicability Determinations and General Information
Form OP-REQ1
Federal Operating Permit Program

Date:	09/03/2024
Permit No.:	4119
RN No.:	RN109161745

For SOP applications, answer ALL questions unless otherwise directed.

◆ *For GOP applications, answer ONLY these questions unless otherwise directed.*

Form OP-REQ1: Page 14	
IV. Title 30 TAC Chapter 117 - Control of Air Pollution from Nitrogen Compounds (continued)	
C. Commercial, Institutional, and Industrial Sources in Ozone Nonattainment Areas	
◆ 1. The application area is located at a site subject to 30 TAC Chapter 117, Subchapter B and includes units specified in 30 TAC §§ 117.100, 117.300, or 117.400. <i>For SOP applications, if the response to Question IV.C.1 is "NO," go to Question IV.D.1. For GOP applications for GOP 517, if the response to Question IV.C.1 is "NO," go to Section IV.F.</i>	<input type="checkbox"/> YES <input type="checkbox"/> NO
◆ 2. The application area is located at a site that was a major source of NO _x before November 15, 1992.	<input type="checkbox"/> YES <input type="checkbox"/> NO <input type="checkbox"/> N/A
◆ 3. The application area includes an electric generating facility required to comply with the System Cap in 30 TAC § 117.320.	<input type="checkbox"/> YES <input type="checkbox"/> NO
D. Adipic Acid Manufacturing	
1. The application area is located at, or part of, an adipic acid production unit.	<input type="checkbox"/> YES <input type="checkbox"/> NO <input type="checkbox"/> N/A
E. Nitric Acid Manufacturing - Ozone Nonattainment Areas	
1. The application area is located at, or part of, a nitric acid production unit.	<input type="checkbox"/> YES <input type="checkbox"/> NO <input type="checkbox"/> N/A
F. Combustion Control at Minor Sources in Ozone Nonattainment Areas - Boilers, Process Heaters, Stationary Engines and Gas Turbines	
◆ 1. The application area is located at a site that is a minor source of NO _x in the Houston/Galveston/Brazoria or Dallas/Fort Worth Eight-Hour areas (except for Wise County). <i>For SOP applications, if the response to Question IV.F.1 is "NO," go to Question IV.G.1. For GOP applications, if the response to Question IV.F.1 is "NO," go to Section VI.</i>	<input type="checkbox"/> YES <input type="checkbox"/> NO
◆ 2. The application area is located in the Houston/Galveston/Brazoria area and has units that qualify for an exemption under 30 TAC § 117.2003(a).	<input type="checkbox"/> YES <input type="checkbox"/> NO
◆ 3. The application area is located in the Houston/Galveston/Brazoria area and has units that qualify for an exemption under 30 TAC § 117.2003(b).	<input type="checkbox"/> YES <input type="checkbox"/> NO

Texas Commission on Environmental Quality
Application Area-Wide Applicability Determinations and General Information
Form OP-REQ1
Federal Operating Permit Program

Date:	09/03/2024
Permit No.:	4119
RN No.:	RN109161745

For SOP applications, answer ALL questions unless otherwise directed.

◆ *For GOP applications, answer ONLY these questions unless otherwise directed.*

Form OP-REQ1: Page 15	
IV. Title 30 TAC Chapter 117 - Control of Air Pollution from Nitrogen Compounds (continued)	
F. Combustion Control at Minor Sources in Ozone Nonattainment Areas - Boilers, Process Heaters, Stationary Engines and Gas Turbines (continued)	
◆ 4. The application area is located in the Dallas/Fort Worth Eight-Hour area (except for Wise County) and has units that qualify for an exemption under 30 TAC § 117.2103.	<input type="checkbox"/> YES <input type="checkbox"/> NO
◆ 5. The application area has units subject to the emission specifications under 30 TAC §§ 117.2010 or 30 TAC § 117.2110.	<input type="checkbox"/> YES <input type="checkbox"/> NO
6. The application area has a unit that has been approved for alternative case specific specifications (ACSS) in 30 TAC § 117.2025 or 30 TAC § 117.2125. <i>If the response to Question IV.F.6 is "NO," go to Section IV.G.</i>	<input type="checkbox"/> YES <input type="checkbox"/> NO
7. An ACSS for carbon monoxide (CO) has been approved?	<input type="checkbox"/> YES <input type="checkbox"/> NO
8. An ACSS for ammonia (NH ₃) has been approved?	<input type="checkbox"/> YES <input type="checkbox"/> NO
9. Provide the Permit Number(s) and authorization/issuance date(s) of the NSR project(s) that incorporates an ACSS below.	
G. Utility Electric Generation in East and Central Texas	
1. The application area includes utility electric power boilers and/or stationary gas turbines (including duct burners used in turbine exhaust ducts) that were placed into service before December 31, 1995. <i>If the response to Question IV.G.1 is "NO," go to Question IV.H.1.</i>	<input type="checkbox"/> YES <input type="checkbox"/> NO
2. The application area is complying with the System Cap in 30 TAC § 117.3020.	<input type="checkbox"/> YES <input type="checkbox"/> NO
H. Multi-Region Combustion Control - Water Heaters, Small Boilers, and Process Heaters	
1. The application area includes a manufacturer, distributor, retailer or installer of natural gas fired water heaters, boilers or process heaters with a maximum rated capacity of 2.0 MMBtu/hr or less. <i>If the response to question IV.H.1 is "NO," go to Section V.</i>	<input type="checkbox"/> YES <input checked="" type="checkbox"/> NO
2. All water heaters, boilers or process heaters manufactured, distributed, retailed or installed qualify for an exemption under 30 TAC § 117.3203.	<input type="checkbox"/> YES <input type="checkbox"/> NO

Texas Commission on Environmental Quality
Application Area-Wide Applicability Determinations and General Information
Form OP-REQ1
Federal Operating Permit Program

Date:	09/03/2024
Permit No.:	4119
RN No.:	RN109161745

For SOP applications, answer ALL questions unless otherwise directed.

◆ *For GOP applications, answer ONLY these questions unless otherwise directed.*

Form OP-REQ1: Page 16	
V. Title 40 Code of Federal Regulations Part 59 (40 CFR Part 59) - National Volatile Organic Compound Emission Standards for Consumer and Commercial Products	
A. Subpart B - National Volatile Organic Compound Emission Standards for Automobile Refinish Coatings	
1. The application area manufactures automobile refinish coatings or coating components and sells or distributes these coatings or coating components in the United States.	<input type="checkbox"/> YES <input checked="" type="checkbox"/> NO
2. The application area imports automobile refinish coatings or coating components, manufactured on or after January 11, 1999, and sells or distributes these coatings or coating components in the United States. <i>If the responses to Questions V.A.1 and V.A.2 are both "NO," go to Section V.B.</i>	<input type="checkbox"/> YES <input checked="" type="checkbox"/> NO
3. All automobile refinish coatings or coating components manufactured or imported by the application area meet one or more of the exemptions specified in 40 CFR § 59.100(c)(1) - (6).	<input type="checkbox"/> YES <input type="checkbox"/> NO
B. Subpart C - National Volatile Organic Compound Emission Standards for Consumer Products	
1. The application area manufactures consumer products for sale or distribution in the United States.	<input type="checkbox"/> YES <input checked="" type="checkbox"/> NO
2. The application area imports consumer products manufactured on or after December 10, 1998 and sells or distributes these consumer products in the United States.	<input type="checkbox"/> YES <input checked="" type="checkbox"/> NO
3. The application area is a distributor of consumer products whose name appears on the label of one or more of the products. <i>If the responses to Questions V.B.1 - V.B.3 are all "NO," go to Section V.C.</i>	<input type="checkbox"/> YES <input checked="" type="checkbox"/> NO
4. All consumer products manufactured, imported, or distributed by the application area meet one or more of the exemptions specified in 40 CFR § 59.201(c)(1) - (7).	<input type="checkbox"/> YES <input type="checkbox"/> NO

Texas Commission on Environmental Quality
Application Area-Wide Applicability Determinations and General Information
Form OP-REQ1
Federal Operating Permit Program

Date:	09/03/2024
Permit No.:	4119
RN No.:	RN109161745

For SOP applications, answer ALL questions unless otherwise directed.

◆ *For GOP applications, answer ONLY these questions unless otherwise directed.*

Form OP-REQ1: Page 17	
V. Title 40 Code of Federal Regulations Part 59 (40 CFR Part 59) - National Volatile Organic Compound Emission Standards for Consumer and Commercial Products (continued)	
C. Subpart D - National Volatile Organic Compound Emission Standards for Architectural Coatings	
1. The application area manufactures or imports architectural coatings for sale or distribution in the United States.	<input type="checkbox"/> YES <input checked="" type="checkbox"/> NO
2. The application area manufactures or imports architectural coatings that are registered under the Federal Insecticide, Fungicide, and Rodenticide Act. <i>If the responses to Questions V.C.1-2 are both "NO," go to Section V.D.</i>	<input type="checkbox"/> YES <input checked="" type="checkbox"/> NO
3. All architectural coatings manufactured or imported by the application area meet one or more of the exemptions specified in 40 CFR §59.400(c)(1)-(5).	<input type="checkbox"/> YES <input type="checkbox"/> NO
D. Subpart E - National Volatile Organic Compound Emission Standards for Aerosol Coatings	
1. The application area manufactures or imports aerosol coating products for sale or distribution in the United States.	<input type="checkbox"/> YES <input checked="" type="checkbox"/> NO
2. The application area is a distributor of aerosol coatings for resale or distribution in the United States.	<input type="checkbox"/> YES <input checked="" type="checkbox"/> NO
E. Subpart F - Control of Evaporative Emissions From New and In-Use Portable Fuel Containers	
1. The application area manufactures or imports portable fuel containers for sale or distribution in the United States. <i>If the response to Question V.E.1 is "NO," go to Section VI.</i>	<input type="checkbox"/> YES <input checked="" type="checkbox"/> NO
2. All portable fuel containers manufactured or imported by the application area meet one or more of the exemptions specified in 40 CFR § 59.605(a) - (c).	<input type="checkbox"/> YES <input type="checkbox"/> NO
VI. Title 40 Code of Federal Regulations Part 60 - New Source Performance Standards	
A. Applicability	
◆ 1. The application area includes a unit(s) that is subject to one or more 40 CFR Part 60 subparts. <i>If the response to Question VI.A.1 is "NO," go to Section VII.</i>	<input checked="" type="checkbox"/> YES <input type="checkbox"/> NO

Texas Commission on Environmental Quality
Application Area-Wide Applicability Determinations and General Information
Form OP-REQ1
Federal Operating Permit Program

Date:	09/03/2024
Permit No.:	4119
RN No.:	RN109161745

For SOP applications, answer ALL questions unless otherwise directed.

◆ *For GOP applications, answer ONLY these questions unless otherwise directed.*

Form OP-REQ1: Page 18	
VI. Title 40 Code of Federal Regulations Part 60 - New Source Performance Standards (continued)	
B. Subpart Y - Standards of Performance for Coal Preparation and Processing Plants	
1. The application area is located at a coal preparation and processing plant. <i>If the response to Question VI.B.1 is "NO," go to Section VI.C.</i>	<input type="checkbox"/> YES <input checked="" type="checkbox"/> NO
2. The coal preparation and processing plant has a design capacity greater than 200 tons per day (tpd). <i>If the response to Question VI.B.2 is "NO," go to Section VI.C.</i>	<input type="checkbox"/> YES <input type="checkbox"/> NO
3. The plant has an option to enforceably limit its operating level to less than 200 tpd and is choosing this option. <i>If the response to Question VI.B.3 is "YES," go to Section VI.C.</i>	<input type="checkbox"/> YES <input type="checkbox"/> NO
4. The plant contains an open storage pile, as defined in § 60.251, as an affected facility. <i>If the response to Question VI.B.4 is "NO," go to Section VI.C.</i>	<input type="checkbox"/> YES <input type="checkbox"/> NO
5. The open storage pile was constructed, reconstructed or modified after May 27, 2009.	<input type="checkbox"/> YES <input type="checkbox"/> NO
C. Subpart GG - Standards of Performance for Stationary Gas Turbines (GOP applicants only)	
◆ 1. The application area includes one or more stationary gas turbines that have a heat input at peak load greater than or equal to 10 MMBtu/hr (10.7GJ/hr), based on the lower heating value of the fuel fired. <i>If the response to Question VI.C.1 is "NO" or "N/A," go to Section VI.D.</i>	<input type="checkbox"/> YES <input checked="" type="checkbox"/> NO <input type="checkbox"/> N/A
◆ 2. One or more of the affected facilities were constructed, modified, or reconstructed after October 3, 1977 and prior to February 19, 2005. <i>If the response to Question VI.C.2 is "NO," go to Section VI.D.</i>	<input type="checkbox"/> YES <input type="checkbox"/> NO
◆ 3. One or more stationary gas turbines in the application area are using a previously approved alternative fuel monitoring schedule as specified in 40 CFR § 60.334(h)(4).	<input type="checkbox"/> YES <input type="checkbox"/> NO
◆ 4. The exemption specified in 40 CFR § 60.332(e) is being utilized for one or more stationary gas turbines in the application area.	<input type="checkbox"/> YES <input type="checkbox"/> NO

Texas Commission on Environmental Quality
Application Area-Wide Applicability Determinations and General Information
Form OP-REQ1
Federal Operating Permit Program

Date:	09/03/2024
Permit No.:	4119
RN No.:	RN109161745

For SOP applications, answer ALL questions unless otherwise directed.

◆ *For GOP applications, answer ONLY these questions unless otherwise directed.*

Form OP-REQ1: Page 19	
VI. Title 40 Code of Federal Regulations Part 60 - New Source Performance Standards (continued)	
C. Subpart GG - Standards of Performance for Stationary Gas Turbines (GOP applicants only) (continued)	
◆ 5. One or more stationary gas turbines subject to 40 CFR Part 60, Subpart GG in the application area is injected with water or steam for the control of nitrogen oxides.	<input type="checkbox"/> YES <input type="checkbox"/> NO
D. Subpart XX - Standards of Performance for Bulk Gasoline Terminals	
1. The application area includes bulk gasoline terminal loading racks. <i>If the response to Question VI.D.1 is "NO," go to Section VI.E.</i>	<input type="checkbox"/> YES <input checked="" type="checkbox"/> NO <input type="checkbox"/> N/A
2. One or more of the loading racks were constructed or modified after December 17, 1980, and are not subject to 40 CFR Part 63, Subpart CC.	<input type="checkbox"/> YES <input type="checkbox"/> NO
E. Subpart LLL - Standards of Performance for Onshore Natural Gas Processing: Sulfur Dioxide (SO₂) Emissions	
◆ 1. The application area includes affected facilities identified in 40 CFR § 60.640(a) that process natural gas (onshore). <i>For SOP applications, if the response to Question VI.E.1 is "NO," go to Section VI.F. For GOP applications, if the response to Question VI.E.1 is "NO" or "N/A," go to Section VI.H.</i>	<input checked="" type="checkbox"/> YES <input type="checkbox"/> NO
◆ 2. The affected facilities commenced construction or modification after January 20, 1984 and on or before August 23, 2011. <i>For SOP applications, if the response to Question VI.E.2 is "NO," go to Section VI.F. For GOP applications, if the response to Question VI.E.2 is "NO," go to Section VI.H.</i>	<input type="checkbox"/> YES <input checked="" type="checkbox"/> NO
◆ 3. The application area includes a gas sweetening unit with a design capacity greater than or equal to 2 long tons per day (LTPD) of hydrogen sulfide but operates at less than 2 LTPD. <i>For SOP applications, if the response to Question VI.E.3 is "NO," go to Section VI.F. For GOP applications, if the response to Question VI.E.3 is "NO," go to Section VI.H.</i>	<input type="checkbox"/> YES <input type="checkbox"/> NO

Texas Commission on Environmental Quality
Application Area-Wide Applicability Determinations and General Information
Form OP-REQ1
Federal Operating Permit Program

Date:	09/03/2024
Permit No.:	4119
RN No.:	RN109161745

For SOP applications, answer ALL questions unless otherwise directed.

◆ *For GOP applications, answer ONLY these questions unless otherwise directed.*

Form OP-REQ1: Page 20	
VI. Title 40 Code of Federal Regulations Part 60 - New Source Performance Standards (continued)	
E. Subpart LLL - Standards of Performance for Onshore Natural Gas Processing: Sulfur Dioxide (SO₂) Emissions (continued)	
◆ 4. Federally enforceable operating limits have been established in the preconstruction authorization limiting the gas sweetening unit to less than 2 LTPD. <i>For SOP applications, if the response to Question VI.E.4. is "NO," go to Section VI.F. For GOP applications, if the response to Question VI.E.4. is "NO," go to Section VI.H.</i>	<input type="checkbox"/> YES <input type="checkbox"/> NO
◆ 5. Please provide the Unit ID(s) for the gas sweetening unit(s) that have established federally enforceable operating limits in the space provided below.	
F. Subpart OOO - Standards of Performance for Nonmetallic Mineral Processing Plants	
1. The application area includes affected facilities identified in 40 CFR § 60.670(a)(1) that are located at a fixed or portable nonmetallic mineral processing plant. <i>If the response to Question VI.F.1 is "NO," go to Section VI.G.</i>	<input type="checkbox"/> YES <input checked="" type="checkbox"/> NO
2. Affected facilities identified in 40 CFR § 60.670(a)(1) and located in the application area are subject to 40 CFR Part 60, Subpart OOO.	<input type="checkbox"/> YES <input type="checkbox"/> NO
G. Subpart QQQ - Standards of Performance for VOC Emissions from Petroleum Refinery Wastewater Systems	
1. The application area is located at a petroleum refinery and includes one or more of the affected facilities identified in 40 CFR § 60.690(a)(2) - (4) for which construction, modification, or reconstruction was commenced after May 4, 1987. <i>If the response to Question VI.G.1 is "NO," go to Section VI.H.</i>	<input type="checkbox"/> YES <input checked="" type="checkbox"/> NO
2. The application area includes storm water sewer systems.	<input type="checkbox"/> YES <input type="checkbox"/> NO

Texas Commission on Environmental Quality
Application Area-Wide Applicability Determinations and General Information
Form OP-REQ1
Federal Operating Permit Program

Date:	09/03/2024
Permit No.:	4119
RN No.:	RN109161745

For SOP applications, answer ALL questions unless otherwise directed.

◆ *For GOP applications, answer ONLY these questions unless otherwise directed.*

Form OP-REQ1: Page 21	
VI. Title 40 Code of Federal Regulations Part 60 - New Source Performance Standards (continued)	
G. Subpart QQQ - Standards of Performance for VOC Emissions from Petroleum Refinery Wastewater Systems (continued)	
3. The application area includes ancillary equipment which is physically separate from the wastewater system and does not come in contact with or store oily wastewater.	<input type="checkbox"/> YES <input type="checkbox"/> NO
4. The application area includes non-contact cooling water systems.	<input type="checkbox"/> YES <input type="checkbox"/> NO
5. The application area includes individual drain systems. <i>If the response to Question VI.G.5 is "NO," go to Section VI.H.</i>	<input type="checkbox"/> YES <input type="checkbox"/> NO
6. The application area includes one or more individual drain systems that meet the exemption specified in 40 CFR § 60.692-2(d).	<input type="checkbox"/> YES <input type="checkbox"/> NO
7. The application area includes completely closed drain systems.	<input type="checkbox"/> YES <input type="checkbox"/> NO
H. Subpart AAAA - Standards of Performance for Small Municipal Waste Incineration Units for Which Construction Commenced After August 30, 1999 or for Which Modification or Reconstruction Commenced on or After June 6, 2004	
◆ 1. The application area includes at least one small municipal waste incineration unit, other than an air curtain incinerator. <i>If the response to Question VI.H.1 is "N/A," go to Section VI.I. If the response to Question VI.H.1 is "NO," go to Question VI.H.4.</i>	<input type="checkbox"/> YES <input checked="" type="checkbox"/> NO <input type="checkbox"/> N/A
◆ 2. The application area includes at least one small municipal waste incineration unit, other than an air curtain incinerator, constructed after August 30, 1999 or modified or reconstructed on or after June 6, 2006.	<input type="checkbox"/> YES <input type="checkbox"/> NO
◆ 3. The application area includes at least one small municipal waste incineration unit, other than an air curtain incinerator, constructed before August 30, 1999 and not modified or reconstructed on or after June 6, 2006.	<input type="checkbox"/> YES <input type="checkbox"/> NO
◆ 4. The application area includes at least one air curtain incinerator. <i>If the response to Question VI.H.4 is "NO," go to Section VI.I.</i>	<input type="checkbox"/> YES <input checked="" type="checkbox"/> NO

Texas Commission on Environmental Quality
Application Area-Wide Applicability Determinations and General Information
Form OP-REQ1
Federal Operating Permit Program

Date:	09/03/2024
Permit No.:	4119
RN No.:	RN109161745

For SOP applications, answer ALL questions unless otherwise directed.

◆ *For GOP applications, answer ONLY these questions unless otherwise directed.*

Form OP-REQ1: Page 22	
VI. Title 40 Code of Federal Regulations Part 60 - New Source Performance Standards (continued)	
H. Subpart AAAA - Standards of Performance for Small Municipal Waste Incineration Units for Which Construction Commenced After August 30, 1999 or for Which Modification or Reconstruction Commenced on or After June 6, 2004 (continued)	
◆ 5. The application area includes at least one air curtain incinerator constructed after August 30, 1999 or modified or reconstructed on or after June 6, 2006. <i>If the response to Question VI.H.5 is "NO," go to Question VI.H.7.</i>	<input type="checkbox"/> YES <input type="checkbox"/> NO
◆ 6. All air curtain incinerators constructed after August 30, 1999 or modified or reconstructed on or after June 6, 2006 combust only yard waste.	<input type="checkbox"/> YES <input type="checkbox"/> NO
◆ 7. The application area includes at least one air curtain incinerator constructed before August 30, 1999 and not modified or reconstructed on or after June 6, 2006.	<input type="checkbox"/> YES <input type="checkbox"/> NO
◆ 8. All air curtain incinerators constructed before August 30, 1999 and not modified or reconstructed on or after June 6, 2006 combust only yard waste.	<input type="checkbox"/> YES <input type="checkbox"/> NO
I. Subpart CCCC - Standards of Performance for Commercial and Industrial Solid Waste Incineration Units for Which Construction Commenced After November 30, 1999 or for Which Modification or Reconstruction Commenced on or After June 1, 2001	
◆ 1. The application area includes at least one commercial or industrial solid waste incineration unit, other than an air curtain incinerator. <i>If the response to Question VI.I.1 is "N/A," go to Section VI.J. If the response to Question VI.I.1 is "NO," go to Question VI.I.4.</i>	<input type="checkbox"/> YES <input checked="" type="checkbox"/> NO <input type="checkbox"/> N/A
◆ 2. The application area includes at least one commercial or industrial solid waste incineration unit, other than an air curtain incinerator, constructed after November 30, 1999 or modified or reconstructed on or after June 1, 2001.	<input type="checkbox"/> YES <input type="checkbox"/> NO

Texas Commission on Environmental Quality
Application Area-Wide Applicability Determinations and General Information
Form OP-REQ1
Federal Operating Permit Program

Date:	09/03/2024
Permit No.:	4119
RN No.:	RN109161745

For SOP applications, answer ALL questions unless otherwise directed.

◆ *For GOP applications, answer ONLY these questions unless otherwise directed.*

Form OP-REQ1: Page 23		
VI. Title 40 Code of Federal Regulations Part 60 - New Source Performance Standards (continued)		
I. Subpart CCCC - Standards of Performance for Commercial and Industrial Solid Waste Incineration Units for Which Construction Commenced After November 30, 1999 or for Which Modification or Reconstruction Commenced on or After June 1, 2001 (continued)		
◆	3. The application area includes at least one commercial or industrial solid waste incineration unit, other than an air curtain incinerator, constructed before November 30, 1999 and not modified or reconstructed on or after June 1, 2001.	<input type="checkbox"/> YES <input type="checkbox"/> NO
◆	4. The application area includes at least one air curtain incinerator. <i>If the response to Question VI.I.4 is "NO," go to Section VI.J.</i>	<input type="checkbox"/> YES <input checked="" type="checkbox"/> NO
◆	5. The application area includes at least one air curtain incinerator, constructed after November 30, 1999 or modified or reconstructed on or after June 1, 2001. <i>If the response to Question VI.I.5 is "NO," go to VI.I.7.</i>	<input type="checkbox"/> YES <input type="checkbox"/> NO
◆	6. All air curtain incinerators constructed after November 30, 1999 or modified or reconstructed on or after June 1, 2001 combust only wood waste, clean lumber, or yard waste or a mixture of these materials.	<input type="checkbox"/> YES <input type="checkbox"/> NO
◆	7. The application area includes at least one air curtain incinerator, constructed before November 30, 1999 and not modified or reconstructed on or after June 1, 2001.	<input type="checkbox"/> YES <input type="checkbox"/> NO
◆	8. All air curtain incinerators constructed before November 30, 1999 and not modified or reconstructed on or after June 1, 2001 combust only wood waste, clean lumber, or yard waste or a mixture of these materials.	<input type="checkbox"/> YES <input type="checkbox"/> NO

Texas Commission on Environmental Quality
Application Area-Wide Applicability Determinations and General Information
Form OP-REQ1
Federal Operating Permit Program

Date:	09/03/2024
Permit No.:	4119
RN No.:	RN109161745

For SOP applications, answer ALL questions unless otherwise directed.

◆ *For GOP applications, answer ONLY these questions unless otherwise directed.*

Form OP-REQ1: Page 24	
VI. Title 40 Code of Federal Regulations Part 60 - New Source Performance Standards (continued)	
J. Subpart EEEE - Standards of Performance for Other Solid Waste Incineration Units for Which Construction Commenced After December 9, 2004 or for Which Modification or Reconstruction Commenced on or After June 16, 2006	
◆ 1. The application area includes at least one very small municipal waste incineration unit or institutional incineration unit, other than an air curtain incinerator. <i>If the response to Question VI.J.1 is "N/A," go to Section VI.K. If the response to Question VI.J.1 is "NO," go to Question VI.J.4.</i>	<input type="checkbox"/> YES <input checked="" type="checkbox"/> NO <input type="checkbox"/> N/A
◆ 2. The application area includes at least one very small municipal waste incineration unit, other than an air curtain incinerator, constructed after December 9, 2004 or modified or reconstructed on or after June 16, 2006.	<input type="checkbox"/> YES <input type="checkbox"/> NO
◆ 3. The application area includes at least one very small municipal waste incineration unit, other than an air curtain incinerator, constructed before December 9, 2004 and not modified or reconstructed on or after June 16, 2006.	<input type="checkbox"/> YES <input type="checkbox"/> NO
◆ 4. The application area includes at least one air curtain incinerator. <i>If the response to Question VI.J.4 is "NO," go to Section VI.K.</i>	<input type="checkbox"/> YES <input checked="" type="checkbox"/> NO
◆ 5. The application area includes at least one air curtain incinerator constructed after December 9, 2004 or modified or reconstructed on or after June 16, 2006. <i>If the response to Question VI.J.5 is "NO," go to Question VI.J.7.</i>	<input type="checkbox"/> YES <input type="checkbox"/> NO
◆ 6. All air curtain incinerators constructed after December 9, 2004 or modified or reconstructed on or after June 16, 2006 combust only wood waste, clean lumber, or yard waste or a mixture of these materials.	<input type="checkbox"/> YES <input type="checkbox"/> NO
◆ 7. The application area includes at least one air curtain incinerator constructed before December 9, 2004 and not modified or reconstructed on or after June 16, 2006.	<input type="checkbox"/> YES <input type="checkbox"/> NO

Texas Commission on Environmental Quality
Application Area-Wide Applicability Determinations and General Information
Form OP-REQ1
Federal Operating Permit Program

Date:	09/03/2024
Permit No.:	4119
RN No.:	RN109161745

For SOP applications, answer ALL questions unless otherwise directed.

◆ *For GOP applications, answer ONLY these questions unless otherwise directed.*

Form OP-REQ1: Page 25	
VI. Title 40 Code of Federal Regulations Part 60 - New Source Performance Standards (NSPS) (continued)	
J. Subpart EEEE - Standards of Performance for Other Solid Waste Incineration Units for Which Construction Commenced After December 9, 2004 or for Which Modification or Reconstruction Commenced on or After June 16, 2006 (continued)	
◆ 8. All air curtain incinerators constructed before December 9, 2004 and not modified or reconstructed on or after June 16, 2006 combust only wood waste, clean lumber, or yard waste or a mixture of these materials.	<input type="checkbox"/> YES <input type="checkbox"/> NO
◆ 9. The air curtain incinerator is located at an institutional facility and is a distinct operating unit of the institutional facility that generated the waste.	<input type="checkbox"/> YES <input type="checkbox"/> NO
◆ 10. The air curtain incinerator burns less than 35 tons per day of wood waste, clean lumber, or yard waste or a mixture of these materials.	<input type="checkbox"/> YES <input type="checkbox"/> NO
K. Subpart OOOO - Standards of Performance for Crude Oil and Natural Gas Production, Transmission and Distribution	
◆ 1. The application area includes one or more of the onshore affected facilities listed in 40 CFR § 60.5365(a)-(g) that are subject to 40 CFR Part 60, Subpart OOOO.	<input type="checkbox"/> YES <input checked="" type="checkbox"/> NO
VII. Title 40 Code of Federal Regulations Part 61 - National Emission Standards for Hazardous Air Pollutants	
A. Applicability	
◆ 1. The application area includes a unit(s) that is subject to one or more 40 CFR Part 61 subparts. <i>If the response to Question VII.A.1 is "NO" or "N/A," go to Section VIII.</i>	YES <input checked="" type="checkbox"/> NO <input type="checkbox"/> N/A
B. Subpart F - National Emission Standard for Vinyl Chloride	
1. The application area is located at a plant which produces ethylene dichloride by reaction of oxygen and hydrogen chloride with ethylene, vinyl chloride by any process, and/or one or more polymers containing any fraction of polymerized vinyl chloride.	YES <input type="checkbox"/> NO
C. Subpart J - National Emission Standard for Benzene Emissions for Equipment Leaks Emission Sources) of Benzene (Complete this section for GOP applications only)	
◆ 1. The application area includes equipment in benzene service.	<input type="checkbox"/> YES <input type="checkbox"/> NO <input type="checkbox"/> N/A

Texas Commission on Environmental Quality
Application Area-Wide Applicability Determinations and General Information
Form OP-REQ1
Federal Operating Permit Program

Date:	09/03/2024
Permit No.:	4119
RN No.:	RN109161745

For SOP applications, answer ALL questions unless otherwise directed.

◆ *For GOP applications, answer ONLY these questions unless otherwise directed.*

Form OP-REQ1: Page 26	
VII. Title 40 Code of Federal Regulations Part 61 - National Emission Standards for Hazardous Air Pollutants (continued)	
D. Subpart L - National Emission Standard for Benzene Emissions from Coke By-Product Recovery Plants	
1. The application area is located at a coke by-product recovery plant and includes one or more of the affected sources identified in 40 CFR § 61.130(a) - (b). <i>If the response to Question VII.D.1 is "NO," go to Section VII.E.</i>	<input type="checkbox"/> YES <input type="checkbox"/> NO
2. The application area includes equipment in benzene service as determined by 40 CFR § 61.137(b).	<input type="checkbox"/> YES <input type="checkbox"/> NO
3. The application area has elected to comply with the provisions of 40 CFR § 61.243-1 and 40 CFR § 61.243-2.	<input type="checkbox"/> YES <input type="checkbox"/> NO
E. Subpart M - National Emission Standard for Asbestos	
<i>Applicability</i>	
1. The application area includes sources, operations, or activities specified in 40 CFR §§ 61.143, 61.144, 61.146, 61.147, 61.148, or 61.155. <i>If the response to Question VII.E.1 is "NO," go to Section VII.F.</i>	<input type="checkbox"/> YES <input type="checkbox"/> NO
<i>Roadway Construction</i>	
2. The application area includes roadways constructed or maintained with asbestos tailings or asbestos-containing waste material.	<input type="checkbox"/> YES <input type="checkbox"/> NO
<i>Manufacturing Commercial Asbestos</i>	
3. The application area includes a manufacturing operation using commercial asbestos. <i>If the response to Question VII.E.3 is "NO," go to Question VII.E.4.</i>	<input type="checkbox"/> YES <input type="checkbox"/> NO
a. Visible emissions are discharged to outside air from the manufacturing operation	<input type="checkbox"/> YES <input type="checkbox"/> NO
b. An alternative emission control and waste treatment method is being used that has received prior U.S. Environmental Protection Agency (EPA) approval.	<input type="checkbox"/> YES <input type="checkbox"/> NO

Texas Commission on Environmental Quality
Application Area-Wide Applicability Determinations and General Information
Form OP-REQ1
Federal Operating Permit Program

Date:	09/03/2024
Permit No.:	4119
RN No.:	RN109161745

For SOP applications, answer ALL questions unless otherwise directed.

◆ *For GOP applications, answer ONLY these questions unless otherwise directed.*

Form OP-REQ1: Page 27	
VII. Title 40 Code of Federal Regulations Part 61 - National Emission Standards for Hazardous Air Pollutants (continued)	
E. Subpart M - National Emission Standard for Asbestos (continued)	
<i>Manufacturing Commercial Asbestos (continued)</i>	
c. Asbestos-containing waste material is processed into non-friable forms.	YES <input type="checkbox"/> NO <input type="checkbox"/>
d. Asbestos-containing waste material is adequately wetted.	YES <input type="checkbox"/> NO <input type="checkbox"/>
e. Alternative filtering equipment is being used that has received EPA approval.	YES <input type="checkbox"/> NO <input type="checkbox"/>
f. A high efficiency particulate air (HEPA) filter is being used that is certified to be at least 99.97% efficient for 0.3 micron particles	YES <input type="checkbox"/> NO <input type="checkbox"/>
g. The EPA has authorized the use of wet collectors designed to operate with a unit contacting energy of at least 9.95 kilopascals.	YES <input type="checkbox"/> NO <input type="checkbox"/>
<i>Asbestos Spray Application</i>	
4. The application area includes operations in which asbestos-containing materials are spray applied. <i>If the response to Question VII.E.4 is "NO," go to Question VII.E.5.</i>	<input type="checkbox"/> YES <input type="checkbox"/> NO
a. Asbestos fibers are encapsulated with a bituminous or resinous binder during spraying and are not friable after drying. <i>If the response to Question VII.E.4.a is "YES," go to Question VII.E.5.</i>	<input type="checkbox"/> YES <input type="checkbox"/> NO
b. Spray-on applications on buildings, structures, pipes, and conduits do not use material containing more than 1% asbestos.	<input type="checkbox"/> YES <input type="checkbox"/> NO
c. An alternative emission control and waste treatment method is being used that has received prior EPA approval.	<input type="checkbox"/> YES <input type="checkbox"/> NO

Texas Commission on Environmental Quality
Application Area-Wide Applicability Determinations and General Information
Form OP-REQ1
Federal Operating Permit Program

Date:	09/03/2024
Permit No.:	4119
RN No.:	RN109161745

For SOP applications, answer ALL questions unless otherwise directed.

◆ *For GOP applications, answer ONLY these questions unless otherwise directed.*

Form OP-REQ1: Page 28	
VII. Title 40 Code of Federal Regulations Part 61 - National Emission Standards for Hazardous Air Pollutants (continued)	
E. Subpart M - National Emission Standard for Asbestos (continued)	
<i>Asbestos Spray Application (continued)</i>	
d. Asbestos-containing waste material is processed into non-friable forms.	YES <input type="checkbox"/> NO <input type="checkbox"/>
e. Asbestos-containing waste material is adequately wetted.	YES <input type="checkbox"/> NO <input type="checkbox"/>
f. Alternative filtering equipment is being used that has received EPA approval.	YES <input type="checkbox"/> NO <input type="checkbox"/>
g. A HEPA filter is being used that is certified to be at least 99.97% efficient for 0.3 micron particles.	YES <input type="checkbox"/> NO <input type="checkbox"/>
h. The EPA has authorized the use of wet collectors designed to operate with a unit contacting energy of at least 9.95 kilopascals.	YES <input type="checkbox"/> NO <input type="checkbox"/>
<i>Fabricating Commercial Asbestos</i>	
5. The application area includes a fabricating operation using commercial asbestos. <i>If the response to Question VII.E.5 is "NO," go to Question VII.E.6.</i>	<input type="checkbox"/> YES <input type="checkbox"/> NO
a. Visible emissions are discharged to outside air from the manufacturing operation.	<input type="checkbox"/> YES <input type="checkbox"/> NO
b. An alternative emission control and waste treatment method is being used that has received prior EPA approval.	<input type="checkbox"/> YES <input type="checkbox"/> NO
c. Asbestos-containing waste material is processed into non-friable forms.	<input type="checkbox"/> YES <input type="checkbox"/> NO
d. Asbestos-containing waste material is adequately wetted.	<input type="checkbox"/> YES <input type="checkbox"/> NO
e. Alternative filtering equipment is being used that has received EPA approval.	<input type="checkbox"/> YES <input type="checkbox"/> NO

Texas Commission on Environmental Quality
Application Area-Wide Applicability Determinations and General Information
Form OP-REQ1
Federal Operating Permit Program

Date:	09/03/2024
Permit No.:	4119
RN No.:	RN109161745

For SOP applications, answer ALL questions unless otherwise directed.

◆ *For GOP applications, answer ONLY these questions unless otherwise directed.*

Form OP-REQ1: Page 29	
VII. Title 40 Code of Federal Regulations Part 61 - National Emission Standards for Hazardous Air Pollutants (continued)	
E. Subpart M - National Emission Standard for Asbestos (continued)	
<i>Fabricating Commercial Asbestos (continued)</i>	
f. A HEPA filter is being used that is certified to be at least 99.97% efficient for 0.3 micron particles.	YES <input type="checkbox"/> NO <input type="checkbox"/>
g. The EPA has authorized the use of wet collectors designed to operate with a unit contacting energy of at least 9.95 kilopascals.	YES <input type="checkbox"/> NO <input type="checkbox"/>
<i>Non-sprayed Asbestos Insulation</i>	
6. The application area includes insulating materials (other than spray applied insulating materials) that are either molded and friable or wet-applied and friable after drying.	YES <input type="checkbox"/> NO <input type="checkbox"/>
<i>Asbestos Conversion</i>	
7. The application area includes operations that convert regulated asbestos-containing material and asbestos-containing waste material into nonasbestos (asbestos-free) material.	<input type="checkbox"/> YES <input type="checkbox"/> NO
F. Subpart P - National Emission Standard for Inorganic Arsenic Emissions from Arsenic Trioxide and Metallic Arsenic Production Facilities	
1. The application area is located at a metallic arsenic production plant or at an arsenic trioxide plant that processes low-grade arsenic bearing materials by a roasting condensation process.	<input type="checkbox"/> YES <input type="checkbox"/> NO
G. Subpart BB - National Emission Standard for Benzene Emissions from Benzene Transfer Operations	
1. The application area is located at a benzene production facility and/or bulk terminal. <i>If the response to Question VII.G.1 is "NO," go to Section VII.H.</i>	<input type="checkbox"/> YES <input type="checkbox"/> NO
2. The application area includes benzene transfer operations at marine vessel loading racks.	<input type="checkbox"/> YES <input type="checkbox"/> NO

Texas Commission on Environmental Quality
Application Area-Wide Applicability Determinations and General Information
Form OP-REQ1
Federal Operating Permit Program

Date:	09/03/2024
Permit No.:	4119
RN No.:	RN109161745

For SOP applications, answer ALL questions unless otherwise directed.

◆ *For GOP applications, answer ONLY these questions unless otherwise directed.*

Form OP-REQ1: Page 30	
VII. Title 40 Code of Federal Regulations Part 61 - National Emission Standards for Hazardous Air Pollutants (continued)	
G. Subpart BB - National Emission Standard for Benzene Emissions from Benzene Transfer Operations (continued)	
3. The application area includes benzene transfer operations at railcar loading racks.	<input type="checkbox"/> YES <input type="checkbox"/> NO
4. The application area includes benzene transfer operations at tank-truck loading racks.	<input type="checkbox"/> YES <input type="checkbox"/> NO
H. Subpart FF - National Emission Standard for Benzene Waste Operations	
Applicability	
1. The application area includes a chemical manufacturing plant, coke by-product recovery plant, or petroleum refinery facility as defined in § 61.341.	<input type="checkbox"/> YES <input type="checkbox"/> NO
2. The application area is located at a hazardous waste treatment, storage, and disposal (TSD) facility site as described in 40 CFR § 61.340(b). <i>If the responses to Questions VII.H.1 and VII.H.2 are both "NO," go to Section VIII.</i>	<input type="checkbox"/> YES <input type="checkbox"/> NO
3. The application area is located at a site that has no benzene onsite in wastes, products, byproducts, or intermediates. <i>If the response to Question VII.H.3 is "YES," go to Section VIII.</i>	<input type="checkbox"/> YES <input type="checkbox"/> NO
4. The application area is located at a site having a total annual benzene quantity from facility waste less than 1 megagram per year (Mg/yr). <i>If the response to Question VII.H.4 is "YES," go to Section VIII</i>	<input type="checkbox"/> YES <input type="checkbox"/> NO
5. The application area is located at a site having a total annual benzene quantity from facility waste greater than or equal to 1 Mg/yr but less than 10 Mg/yr. <i>If the response to Question VII.H.5 is "YES," go to Section VIII.</i>	<input type="checkbox"/> YES <input type="checkbox"/> NO

Texas Commission on Environmental Quality
Application Area-Wide Applicability Determinations and General Information
Form OP-REQ1
Federal Operating Permit Program

Date:	09/03/2024
Permit No.:	4119
RN No.:	RN109161745

For SOP applications, answer ALL questions unless otherwise directed.

◆ *For GOP applications, answer ONLY these questions unless otherwise directed.*

Form OP-REQ1: Page 31	
VII. Title 40 Code of Federal Regulations Part 61 - National Emission Standards for Hazardous Air Pollutants (continued)	
H. Subpart FF - National Emission Standard for Benzene Waste Operations (continued)	
Applicability (continued)	
6. The flow-weighted annual average benzene concentration of each waste stream at the site is based on documentation.	<input type="checkbox"/> YES <input type="checkbox"/> NO
7. The application area has waste streams with flow-weighted annual average water content of 10% or greater.	<input type="checkbox"/> YES <input type="checkbox"/> NO
Waste Stream Exemptions	
8. The application area has waste streams that meet the exemption specified in 40 CFR § 61.342(c)(2) (the flow-weighted annual average benzene concentration is less than 10 ppmw).	<input type="checkbox"/> YES <input type="checkbox"/> NO
9. The application area has waste streams that meet the exemption specified in 40 CFR § 61.342(c)(3) because process wastewater has a flow rate less than 0.02 liters per minute or an annual wastewater quantity less than 10 Mg/yr.	<input type="checkbox"/> YES <input type="checkbox"/> NO
10. The application area has waste streams that meet the exemption specified in 40 CFR § 61.342(c)(3) because the total annual benzene quantity is less than or equal to 2 Mg/yr.	<input type="checkbox"/> YES <input type="checkbox"/> NO
11. The application area transfers waste off-site for treatment by another facility.	<input type="checkbox"/> YES <input type="checkbox"/> NO
12. The application area is complying with 40 CFR § 61.342(d).	<input type="checkbox"/> YES <input type="checkbox"/> NO
13. The application area is complying with 40 CFR § 61.342(e). <i>If the response to Question VII.H.13 is "NO," go to Question VII.H.15.</i>	<input type="checkbox"/> YES <input type="checkbox"/> NO
14. The application area has facility waste with a flow weighted annual average water content of less than 10%.	<input type="checkbox"/> YES <input type="checkbox"/> NO

Texas Commission on Environmental Quality
Application Area-Wide Applicability Determinations and General Information
Form OP-REQ1
Federal Operating Permit Program

Date:	09/03/2024
Permit No.:	4119
RN No.:	RN109161745

For SOP applications, answer ALL questions unless otherwise directed.

◆ *For GOP applications, answer ONLY these questions unless otherwise directed.*

Form OP-REQ1: Page 32	
VII. Title 40 Code of Federal Regulations Part 61 - National Emission Standards for Hazardous Air Pollutants (continued)	
H. Subpart FF - National Emission Standard for Benzene Waste Operations (continued)	
Container Requirements	
15. The application area has containers, as defined in 40 CFR § 61.341, that receive non-exempt benzene waste. <i>If the response to Question VII.H.15 is "NO," go to Question VII.H.18.</i>	<input type="checkbox"/> YES <input type="checkbox"/> NO
16. The application area is an alternate means of compliance to meet the 40 CFR § 61.345 requirements for containers. <i>If the response to Question VII.H.16 is "YES," go to Question VII.H.18.</i>	<input type="checkbox"/> YES <input type="checkbox"/> NO
17. Covers and closed-vent systems used for containers operate such that the container is maintained at a pressure less than atmospheric pressure.	<input type="checkbox"/> YES <input type="checkbox"/> NO
Individual Drain Systems	
18. The application area has individual drain systems, as defined in 40 CFR § 61.341, that receive or manage non-exempt benzene waste. <i>If the response to Question VII.H.18 is "NO," go to Question VII.H.25.</i>	<input type="checkbox"/> YES <input type="checkbox"/> NO
19. The application area is using an alternate means of compliance to meet the 40 CFR § 61.346 requirements for individual drain systems. <i>If the response to Question VII.H.19 is "YES," go to Question VII.H.25.</i>	<input type="checkbox"/> YES <input type="checkbox"/> NO
20. The application area has individual drain systems complying with 40 CFR § 61.346(a). <i>If the response to Question VII.H.20 is "NO," go to Question VII.H.22.</i>	<input type="checkbox"/> YES <input type="checkbox"/> NO
21. Covers and closed-vent systems used for individual drain systems operate such that the individual drain system is maintained at a pressure less than atmospheric pressure.	<input type="checkbox"/> YES <input type="checkbox"/> NO

Texas Commission on Environmental Quality
Application Area-Wide Applicability Determinations and General Information
Form OP-REQ1
Federal Operating Permit Program

Date:	09/03/2024
Permit No.:	4119
RN No.:	RN109161745

For SOP applications, answer ALL questions unless otherwise directed.

◆ *For GOP applications, answer ONLY these questions unless otherwise directed.*

Form OP-REQ1: Page 33	
VII. Title 40 Code of Federal Regulations Part 61 - National Emission Standards for Hazardous Air Pollutants (continued)	
H. Subpart FF - National Emission Standard for Benzene Waste Operations (continued)	
<i>Individual Drain Systems (continued)</i>	
22. The application area has individual drain systems complying with 40 CFR § 61.346(b). <i>If the response to Question VII.H.22 is "NO," go to Question VII.H.25.</i>	YES <input type="checkbox"/> NO <input type="checkbox"/>
23. Junction boxes in the individual drain systems are equipped with a system to prevent the flow of organic vapors from the junction box vent pipe to the atmosphere during normal operation.	YES <input type="checkbox"/> NO <input type="checkbox"/>
24. Junction box vent pipes in the individual drain systems are connected to a closed-vent system and control device.	YES <input type="checkbox"/> NO <input type="checkbox"/>
<i>Remediation Activities</i>	
25. Remediation activities take place at the application area subject to 40 CFR Part 61, Subpart FF.	YES <input type="checkbox"/> NO <input type="checkbox"/>
VIII. Title 40 Code of Federal Regulations Part 63 - National Emission Standards for Hazardous Air Pollutants for Source Categories	
A. Applicability	
◆ 1. The application area includes a unit(s) that is subject to one or more 40 CFR Part 63 subparts other than subparts made applicable by reference under subparts in 40 CFR Part 60, 61 or 63. <i>See instructions for 40 CFR Part 63 subparts made applicable only by reference.</i>	<input checked="" type="checkbox"/> YES <input type="checkbox"/> NO
B. Subpart F - National Emission Standards for Organic Hazardous Air Pollutants from the Synthetic Organic Chemical Manufacturing Industry	
1. The application area is located at a plant site that is a major source as defined in the Federal Clean Air Act § 112(a). <i>If the response to Question VIII.B.1 is "NO," go to Section VIII.D.</i>	<input type="checkbox"/> YES <input checked="" type="checkbox"/> NO

Texas Commission on Environmental Quality
Application Area-Wide Applicability Determinations and General Information
Form OP-REQ1
Federal Operating Permit Program

Date:	09/03/2024
Permit No.:	4119
RN No.:	RN109161745

For SOP applications, answer ALL questions unless otherwise directed.

◆ *For GOP applications, answer ONLY these questions unless otherwise directed.*

Form OP-REQ1: Page 34	
VIII. Title 40 Code of Federal Regulations Part 63 - National Emission Standards for Hazardous Air Pollutants for Source Categories (continued)	
B. Subpart F - National Emission Standards for Organic Hazardous Air Pollutants from the Synthetic Organic Chemical Manufacturing Industry (continued)	
<p>2. The application area is located at a site that includes at least one chemical manufacturing process unit, as defined in 40 CFR § 63.101, that manufactures as a primary product one or more of the chemicals listed in 40 CFR § 63.100(b)(1)(i) or (b)(1)(ii). <i>If the response to Question VIII.B.2 is "NO," go to Section VIII.D.</i></p>	<input type="checkbox"/> YES <input type="checkbox"/> NO
<p>3. The application area is located at a site that includes at least one chemical manufacturing process unit, as defined in 40 CFR § 63.101, that manufactures as a primary product one or more of the chemicals listed in 40 CFR § 63.100(b)(1)(i) or (b)(1)(ii) and uses as a reactant or manufactures as a product, or co-product, one or more of the organic hazardous air pollutants listed in table 2 of 40 CFR Part 63, Subpart F.</p>	<input type="checkbox"/> YES <input type="checkbox"/> NO
<p>4. The application area includes a chemical manufacturing process unit, as defined in 40 CFR § 63.101, that manufactures as a primary product one or more of the chemicals listed in 40 CFR § 63.100(b)(1)(i) or (b)(1)(ii) and uses as a reactant or manufactures as a product, or co-product, one or more of the organic hazardous air pollutants listed in table 2 of 40 CFR Part 63, Subpart F.</p>	<input type="checkbox"/> YES <input type="checkbox"/> NO
<p>5. The application area includes a chemical manufacturing process unit, as defined in 40 CFR § 63.101, that manufactures as a primary product one or more of the chemicals listed in 40 CFR § 63.100(b)(1)(i) or (b)(1)(ii) and does <u>not</u> use as a reactant or manufacture as a product, or co-product, one or more of the organic hazardous air pollutants listed in table 2 of 40 CFR Part 63, Subpart F. <i>If the response to Questions VIII.B.3, B.4 and B.5 are all "NO," go to Section VIII.D.</i></p>	<input type="checkbox"/> YES <input type="checkbox"/> NO

Texas Commission on Environmental Quality
Application Area-Wide Applicability Determinations and General Information
Form OP-REQ1
Federal Operating Permit Program

Date:	09/03/2024
Permit No.:	4119
RN No.:	RN109161745

For SOP applications, answer ALL questions unless otherwise directed.

◆ *For GOP applications, answer ONLY these questions unless otherwise directed.*

Form OP-REQ1: Page 35	
VIII. Title 40 Code of Federal Regulations Part 63 - National Emission Standards for Hazardous Air Pollutants for Source Categories (continued)	
C. Subpart G - National Emission Standards for Organic Hazardous Air Pollutants from the Synthetic Organic Chemical Manufacturing Industry for Process Vents, Storage Vessels, Transfer Operations, and Wastewater	
<i>Applicability</i>	
1. The application area is located at a site that is subject to 40 CFR 63, Subpart F and the application area includes process vents, storage vessels, transfer racks, or waste streams associated with a chemical manufacturing process subject to 40 CFR 63, Subpart F. <i>If the response to Question VIII.C.1 is "NO," go to Section VIII.D.</i>	<input type="checkbox"/> YES <input type="checkbox"/> NO
2. The application area includes fixed roofs, covers, and/or enclosures that are required to comply with 40 CFR § 63.148.	<input type="checkbox"/> YES <input type="checkbox"/> NO
3. The application area includes vapor collection systems or closed-vent systems that are required to comply with 40 CFR § 63.148. <i>If the response to Question VIII.C.3 is "NO," go to Question VIII.C.8.</i>	<input type="checkbox"/> YES <input type="checkbox"/> NO
4. The application area includes vapor collection systems or closed-vent systems that are constructed of hard-piping.	<input type="checkbox"/> YES <input type="checkbox"/> NO
5. The application area includes vapor collection systems or closed-vent systems that contain bypass lines that could divert a vent stream away from a control device and to the atmosphere. <i>If the response to Question VIII.C.5 is "NO," go to Question VIII.C.8.</i>	<input type="checkbox"/> YES <input type="checkbox"/> NO
<i>Vapor Collection and Closed Vent Systems</i>	
6. Flow indicators are installed, calibrated, maintained, and operated at the entrances to bypass lines in the application area.	<input type="checkbox"/> YES <input type="checkbox"/> NO
7. Bypass lines in the application area are secured in the closed position with a car-seal or a lock-and-key type configuration.	<input type="checkbox"/> YES <input type="checkbox"/> NO

Texas Commission on Environmental Quality
Application Area-Wide Applicability Determinations and General Information
Form OP-REQ1
Federal Operating Permit Program

Date:	09/03/2024
Permit No.:	4119
RN No.:	RN109161745

For SOP applications, answer ALL questions unless otherwise directed.

◆ *For GOP applications, answer ONLY these questions unless otherwise directed.*

Form OP-REQ1: Page 36	
VIII. Title 40 Code of Federal Regulations Part 63 - National Emission Standards for Hazardous Air Pollutants for Source Categories (continued)	
C. Subpart G - National Emission Standards for Organic Hazardous Air Pollutants from the Synthetic Organic Chemical Manufacturing Industry for Process Vents, Storage Vessels, Transfer Operations, and Wastewater (continued)	
<i>Reloading or Cleaning of Railcars, Tank Trucks, or Barges</i>	
8. The application area includes reloading and/or cleaning of railcars, tank trucks, or barges that deliver HAPs to a storage tank. <i>If the response to Question VIII.C.8 is "NO," go to Question VIII.C.11.</i>	<input type="checkbox"/> YES <input type="checkbox"/> NO
9. The application area includes operations that are complying with § 63.119(g)(6) through the use of a closed-vent system with a control device used to reduce inlet emissions of HAPs by at least 95 percent by weight or greater.	<input type="checkbox"/> YES <input type="checkbox"/> NO
10. The application area includes operations that are complying with § 63.119(g)(6) through the use of a vapor balancing system.	<input type="checkbox"/> YES <input type="checkbox"/> NO
<i>Transfer Racks</i>	
11. The application area includes Group 1 transfer racks that load organic HAPs.	<input type="checkbox"/> YES <input type="checkbox"/> NO
<i>Process Wastewater Streams</i>	
12. The application area includes process wastewater streams. <i>If the response to Question VIII.C.12 is "NO," go to Question VIII.C.34.</i>	<input type="checkbox"/> YES <input type="checkbox"/> NO
13. The application area includes process wastewater streams that are also subject to the provisions of 40 CFR Part 61, Subpart FF. <i>If the response to Question VIII.C.13 is "NO," go to Question VIII.C.15.</i>	<input type="checkbox"/> YES <input type="checkbox"/> NO
14. The application area includes process wastewater streams that are complying with 40 CFR §§ 63.110(e)(1)(i) and (e)(1)(ii).	<input type="checkbox"/> YES <input type="checkbox"/> NO
15. The application area includes process wastewater streams that are also subject to the provisions of 40 CFR Part 61, Subpart F. <i>If the response to Question VIII.C.15 is "NO," go to Question VIII.C.17.</i>	<input type="checkbox"/> YES <input type="checkbox"/> NO

Texas Commission on Environmental Quality
Application Area-Wide Applicability Determinations and General Information
Form OP-REQ1
Federal Operating Permit Program

Date:	09/03/2024
Permit No.:	4119
RN No.:	RN109161745

For SOP applications, answer ALL questions unless otherwise directed.

◆ *For GOP applications, answer ONLY these questions unless otherwise directed.*

Form OP-REQ1: Page 37	
VIII. Title 40 Code of Federal Regulations Part 63 - National Emission Standards for Hazardous Air Pollutants for Source Categories (continued)	
C. Subpart G - National Emission Standards for Organic Hazardous Air Pollutants from the Synthetic Organic Chemical Manufacturing Industry for Process Vents, Storage Vessels, Transfer Operations, and Wastewater (continued)	
Process Wastewater Streams (continued)	
16. The application area includes process wastewater streams utilizing the compliance option specified in 40 CFR § 63.110(f)(4)(ii).	<input type="checkbox"/> YES <input type="checkbox"/> NO
17. The application area includes process wastewater streams that are also subject to the provisions of 40 CFR Parts 260 through 272. <i>If the response to Question VIII.C.17 is "NO," go to Question VIII.C.20.</i>	<input type="checkbox"/> YES <input type="checkbox"/> NO
18. The application area includes process wastewater streams complying with 40 CFR § 63.110(e)(2)(i).	<input type="checkbox"/> YES <input type="checkbox"/> NO
19. The application are includes process wastewater streams complying with 40 CFR § 63.110(e)(2)(ii).	<input type="checkbox"/> YES <input type="checkbox"/> NO
20. The application area includes process wastewater streams, located at existing sources, that are designated as Group 1; are required to be treated as Group 1 under 40 CFR § 63.110; or are determined to be Group 1 for Table 9 compounds.	<input type="checkbox"/> YES <input type="checkbox"/> NO
21. The application area includes process wastewater streams, located at existing sources that are Group 2.	<input type="checkbox"/> YES <input type="checkbox"/> NO
22. The application area includes process wastewater streams, located at new sources, that are designated as Group 1; required to be treated as Group 1 under 40 CFR § 63.110; or are determined to be Group 1 for Table 8 or Table 9 compounds.	<input type="checkbox"/> YES <input type="checkbox"/> NO
23. The application area includes process wastewater streams, located at new sources that are Group 2 for both Table 8 and Table 9 compounds.	<input type="checkbox"/> YES <input type="checkbox"/> NO

Texas Commission on Environmental Quality
Application Area-Wide Applicability Determinations and General Information
Form OP-REQ1
Federal Operating Permit Program

Date:	09/03/2024
Permit No.:	4119
RN No.:	RN109161745

For SOP applications, answer ALL questions unless otherwise directed.

◆ *For GOP applications, answer ONLY these questions unless otherwise directed.*

Form OP-REQ1: Page 38	
VIII. Title 40 Code of Federal Regulations Part 63 - National Emission Standards for Hazardous Air Pollutants for Source Categories (continued)	
C. Subpart G - National Emission Standards for Organic Hazardous Air Pollutants from the Synthetic Organic Chemical Manufacturing Industry for Process Vents, Storage Vessels, Transfer Operations, and Wastewater (continued)	
Process Wastewater Streams (continued)	
24. All Group 1 wastewater streams at the site are demonstrated to have a total source mass flow rate of less than 1 MG/yr. <i>If the response to Question VIII.C.24 is "YES," go to Question VIII.C.34.</i>	<input type="checkbox"/> YES <input type="checkbox"/> NO
25. The site has untreated and/or partially treated Group 1 wastewater streams demonstrated to have a total source mass flow rate of less than 1 MG/yr. <i>If the response to Question VIII.C.25 is "NO," go to Question VIII.C.27.</i>	<input type="checkbox"/> YES <input type="checkbox"/> NO
26. The application area includes waste management units that receive or manage a partially treated Group 1 wastewater stream prior to or during treatment.	<input type="checkbox"/> YES <input type="checkbox"/> NO
27. Group 1 wastewater streams or residual removed from Group 1 wastewater streams are transferred to an on-site treatment operation that is not owned or operated by the owner or operator of the source generating the waste stream or residual.	<input type="checkbox"/> YES <input type="checkbox"/> NO
28. Group 1 wastewater streams or residual removed from Group 1 wastewater streams are transferred to an off-site treatment operation. <i>If the responses to Questions VIII.C.27 - VIII.C.28 are both "NO," go to Question VIII.C.30.</i>	<input type="checkbox"/> YES <input type="checkbox"/> NO
29. The application area includes waste management units that receive or manage a Group 1 wastewater stream or a residual removed from a Group 1 wastewater stream prior to shipment or transport.	<input type="checkbox"/> YES <input type="checkbox"/> NO
30. The application area includes containers that receive, manage, or treat a Group 1 wastewater stream or a residual removed from a Group 1 wastewater stream.	<input type="checkbox"/> YES <input type="checkbox"/> NO

Texas Commission on Environmental Quality
Application Area-Wide Applicability Determinations and General Information
Form OP-REQ1
Federal Operating Permit Program

Date:	09/03/2024
Permit No.:	4119
RN No.:	RN109161745

For SOP applications, answer ALL questions unless otherwise directed.

◆ *For GOP applications, answer ONLY these questions unless otherwise directed.*

Form OP-REQ1: Page 39	
VIII. Title 40 Code of Federal Regulations Part 63 - National Emission Standards for Hazardous Air Pollutants for Source Categories (continued)	
C. Subpart G - National Emission Standards for Organic Hazardous Air Pollutants from the Synthetic Organic Chemical Manufacturing Industry for Process Vents, Storage Vessels, Transfer Operations, and Wastewater (continued)	
<i>Drains</i>	
31. The application area includes individual drain systems that receive or manage a Group 1 wastewater stream, or a residual removed from a Group 1 wastewater stream. <i>If the response to Question VIII.C.31 is "NO," go to Question VIII.C.34.</i>	<input type="checkbox"/> YES <input type="checkbox"/> NO
32. The application area includes individual drain systems that are complying with 40 CFR § 63.136 through the use of cover and, if vented, closed vent systems and control devices.	<input type="checkbox"/> YES <input type="checkbox"/> NO
33. The application area includes individual drain systems that are complying with 40 CFR § 63.136 through the use of water seals or tightly fitting caps or plugs.	<input type="checkbox"/> YES <input type="checkbox"/> NO
34. The application area includes drains, drain hubs, manholes, lift stations, trenches, or pipes that are part of a chemical manufacturing process unit that meets the criteria of 40 CFR § 63.100(b). <i>If the response to Question VIII.C.34 is "NO," go to Question VIII.C.39.</i>	<input type="checkbox"/> YES <input type="checkbox"/> NO
35. The application area includes drains, drain hubs, manholes, lift stations, trenches or pipes (that are part of a chemical manufacturing process unit) that meet the criteria listed in 40 CFR § 63.149(d). <i>If the response to Question VIII.C.35 is "NO," go to Question VIII.C.39.</i>	<input type="checkbox"/> YES <input type="checkbox"/> NO
36. The application area includes drains, drain hubs, manholes, lift stations, trenches, or pipes that convey water with a total annual average concentration greater than or equal to 10,000 parts per million by weight of compounds listed in 40 CFR Part 63 Subpart G, Table 9, at any flow rate.	<input type="checkbox"/> YES <input type="checkbox"/> NO

Texas Commission on Environmental Quality
Application Area-Wide Applicability Determinations and General Information
Form OP-REQ1
Federal Operating Permit Program

Date:	09/03/2024
Permit No.:	4119
RN No.:	RN109161745

For SOP applications, answer ALL questions unless otherwise directed.

◆ *For GOP applications, answer ONLY these questions unless otherwise directed.*

Form OP-REQ1: Page 40	
VIII. Title 40 Code of Federal Regulations Part 63 - National Emission Standards for Hazardous Air Pollutants for Source Categories (continued)	
C. Subpart G-National Emission Standards for Organic Hazardous Air Pollutants from the Synthetic Organic Chemical Manufacturing Industry for Process Vents, Storage Vessels, Transfer Operation, and Wastewater (continued)	
Drains (continued)	
37. The application area includes drains, drain hubs, manholes, lift stations, trenches or pipes that convey water with a total annual average concentration greater than or equal to 1,000 parts per million by weight of compounds listed in 40 CFR Part 63 Subpart G, Table 9, at an annual average flow rate greater than or equal to 10 liters per minute.	<input type="checkbox"/> YES <input type="checkbox"/> NO
38. The application area includes drains, drain hubs, manholes, lift stations, trenches or pipes that are part of a chemical manufacturing process unit that is subject to the new source requirements of 40 CFR § 63.100(l)(1) or (l)(2); and the equipment conveys water with a total annual average concentration greater than or equal to 10 parts per million by weight of compounds listed in 40 CFR Part 63 Subpart G, Table 8, at an average annual flow rate greater than or equal to 0.02 liter per minute.	<input type="checkbox"/> YES <input type="checkbox"/> NO
Gas Streams	
39. The application area includes gas streams meeting the characteristics of 40 CFR § 63.107(b) - (h) or the criteria of 40 CFR § 63.113(i) and are transferred to a control device not owned or operated by the applicant.	<input type="checkbox"/> YES <input type="checkbox"/> NO
40. The applicant is unable to comply with 40 CFR §§ 63.113 - 63.118 for one or more reasons described in 40 CFR § 63.100(q)(1), (3), or (5).	<input type="checkbox"/> YES <input type="checkbox"/> NO
D. Subpart N - National Emission Standards for Chromium Emissions From Hard and Decorative Chromium Electroplating and Chromium Anodizing Tanks	
1. The application area includes chromium electroplating or chromium anodizing tanks located at hard chromium electroplating, decorative chromium electroplating, and/or chromium anodizing operations.	<input type="checkbox"/> YES <input checked="" type="checkbox"/> NO

Texas Commission on Environmental Quality
Application Area-Wide Applicability Determinations and General Information
Form OP-REQ1
Federal Operating Permit Program

Date:	09/03/2024
Permit No.:	4119
RN No.:	RN109161745

For SOP applications, answer ALL questions unless otherwise directed.

◆ *For GOP applications, answer ONLY these questions unless otherwise directed.*

Form OP-REQ1: Page 41	
VIII. Title 40 Code of Federal Regulations Part 63 - National Emission Standards for Hazardous Air Pollutants for Source Categories (continued)	
E. Subpart O - Ethylene Oxide Emissions Standards for Sterilization Facilities	
1. The application area includes sterilization facilities where ethylene oxide is used in the sterilization or fumigation of materials. <i>If the response to Question VIII.E.1 is "NO," go to Section VIII.F.</i>	<input type="checkbox"/> YES <input checked="" type="checkbox"/> NO
2. Sterilization facilities located in the application area are subject to 40 CFR Part 63, Subpart O. <i>If the response to Question VIII.E.2 is "NO," go to Section VIII.F.</i>	<input type="checkbox"/> YES <input type="checkbox"/> NO
3. The sterilization source has used less than 1 ton (907 kg) of ethylene oxide within all consecutive 12-month periods after December 6, 1996.	<input type="checkbox"/> YES <input type="checkbox"/> NO
4. The sterilization source has used less than 10 tons (9070 kg) of ethylene oxide within all consecutive 12-month periods after December 6, 1996.	<input type="checkbox"/> YES <input type="checkbox"/> NO
F. Subpart Q - National Emission Standards for Industrial Process Cooling Towers	
1. The application area includes industrial process cooling towers. <i>If the response to Question VIII.F.1 is "NO," go to Section VIII.G.</i>	<input type="checkbox"/> YES <input checked="" type="checkbox"/> NO
2. Chromium-based water treatment chemicals have been used on or after September 8, 1994.	<input type="checkbox"/> YES <input type="checkbox"/> NO
G. Subpart R - National Emission Standards for Gasoline Distribution Facilities (Bulk Gasoline Terminals and Pipeline Breakout Stations)	
1. The application area includes a bulk gasoline terminal.	<input type="checkbox"/> YES <input checked="" type="checkbox"/> NO
2. The application area includes a pipeline breakout station. <i>If the responses to Questions VIII.G.1 and VIII.G.2 are both "NO," go to Section VIII.H.</i>	<input type="checkbox"/> YES <input checked="" type="checkbox"/> NO
3. The bulk gasoline terminal or pipeline breakout station is located within a contiguous area and under common control with another bulk gasoline terminal or a pipeline breakout station. <i>If the response to Question VIII.G.3 is "YES," go to Question VIII.G.10.</i>	<input type="checkbox"/> YES <input type="checkbox"/> NO

Texas Commission on Environmental Quality
Application Area-Wide Applicability Determinations and General Information
Form OP-REQ1
Federal Operating Permit Program

Date:	09/03/2024
Permit No.:	4119
RN No.:	RN109161745

For SOP applications, answer ALL questions unless otherwise directed.

◆ *For GOP applications, answer ONLY these questions unless otherwise directed.*

Form OP-REQ1: Page 42	
VIII. Title 40 Code of Federal Regulations Part 63 - National Emission Standards for Hazardous Air Pollutants for Source Categories (continued)	
G. Subpart R - National Emission Standards for Gasoline Distribution Facilities (Bulk Gasoline Terminals and Pipeline Breakout Stations) (continued)	
4. The bulk gasoline terminal or pipeline breakout station is located within a contiguous area and under common control with sources, other than bulk gasoline terminals or pipeline breakout stations that emit or have the potential to emit HAPs. <i>If the response to Question VIII.G.4 is "YES," go to Question VIII.G.10.</i>	<input type="checkbox"/> YES <input type="checkbox"/> NO
5. An emissions screening factor was calculated for the bulk gasoline terminal or pipeline breakout station. <i>If the response to Question VIII.G.5 is "NO," go to Question VIII.G.10.</i>	<input type="checkbox"/> YES <input type="checkbox"/> NO
6. The value 0.04(OE) is less than 5% of the value of the bulk gasoline terminal emissions screening factor (ET) or the pipeline breakout station emissions screening factor (Ep). <i>If the response to Question VIII.G.6 is "NO," go to Question VIII.G.10.</i>	<input type="checkbox"/> YES <input type="checkbox"/> NO
7. Emissions screening factor less than 0.5 (ET or EP < 0.5). <i>If the response to Question VIII.G.7 is "YES," go to Section VIII.H.</i>	<input type="checkbox"/> YES <input type="checkbox"/> NO
8. Emissions screening factor greater than or equal to 0.5, but less than 1.0 (0.5 ≤ ET or EP < 1.0). <i>If the response to Question VIII.G.8 is "YES," go to Section VIII.H.</i>	<input type="checkbox"/> YES <input type="checkbox"/> NO
9. Emissions screening factor greater than or equal to 1.0 (ET or EP ≥ 1.0). <i>If the response to Question VIII.G.9 is "YES," go to Question VIII.G.11.</i>	<input type="checkbox"/> YES <input type="checkbox"/> NO
10. The site at which the application area is located is a major source of HAP. <i>If the response to Question VIII.G.10 is "NO," go to Section VIII.H.</i>	<input type="checkbox"/> YES <input type="checkbox"/> NO
11. The application area is using an alternative leak monitoring program as described in 40 CFR § 63.424(f).	<input type="checkbox"/> YES <input type="checkbox"/> NO

Texas Commission on Environmental Quality
Application Area-Wide Applicability Determinations and General Information
Form OP-REQ1
Federal Operating Permit Program

Date:	09/03/2024
Permit No.:	4119
RN No.:	RN109161745

For SOP applications, answer ALL questions unless otherwise directed.

◆ *For GOP applications, answer ONLY these questions unless otherwise directed.*

Form OP-REQ1: Page 43	
VIII. Title 40 Code of Federal Regulations Part 63 - National Emission Standards for Hazardous Air Pollutants for Source Categories (continued)	
H. Subpart S - National Emission Standards for Hazardous Air Pollutants from the Pulp and Paper Industry	
1. The application area includes processes that produce pulp, paper, or paperboard and are located at a plant site that is a major source of HAPs as defined in 40 CFR § 63.2. <i>If the response to Question VIII.H.1 is "NO," go to Section VIII.I.</i>	<input type="checkbox"/> YES <input checked="" type="checkbox"/> NO
2. The application area uses processes and materials specified in 40 CFR § 63.440(a)(1) - (3). <i>If the response to Question VIII.H.2 is "NO," go to Section VIII.I.</i>	<input type="checkbox"/> YES <input type="checkbox"/> NO
3. The application area includes one or more sources subject to 40 CFR Part 63, Subpart S that are existing sources. <i>If the response to Question VIII.H.3 is "NO," go to Section VIII.I.</i>	<input type="checkbox"/> YES <input type="checkbox"/> NO
4. The application area includes one or more kraft pulping systems that are existing sources.	<input type="checkbox"/> YES <input type="checkbox"/> NO
5. The application area includes one or more dissolving-grade bleaching systems that are existing sources at a kraft or sulfite pulping mill.	<input type="checkbox"/> YES <input type="checkbox"/> NO
6. The application area includes bleaching systems that are existing sources and are complying with the Voluntary Advanced Technology Incentives Program for Effluent Limitation Guidelines in 40 CFR § 430.24. <i>If the response to Question VIII.H.6 is "NO," go to Section VIII.I.</i>	<input type="checkbox"/> YES <input type="checkbox"/> NO
7. The application area includes bleaching systems that are complying with 40 CFR § 63.440(d)(3)(i).	<input type="checkbox"/> YES <input type="checkbox"/> NO
8. The application area includes bleaching systems that are complying with 40 CFR § 63.440(d)(3)(ii).	<input type="checkbox"/> YES <input type="checkbox"/> NO

Texas Commission on Environmental Quality
Application Area-Wide Applicability Determinations and General Information
Form OP-REQ1
Federal Operating Permit Program

Date:	09/03/2024
Permit No.:	4119
RN No.:	RN109161745

For SOP applications, answer ALL questions unless otherwise directed.

◆ *For GOP applications, answer ONLY these questions unless otherwise directed.*

Form OP-REQ1: Page 44	
VIII. Title 40 Code of Federal Regulations Part 63 - National Emission Standards for Hazardous Air Pollutants for Source Categories (continued)	
I. Subpart T - National Emission Standards for Halogenated Solvent Cleaning	
1. The application area includes an individual batch vapor, in-line vapor, in-line cold, and/or batch cold solvent cleaning machine that uses a hazardous air pollutant (HAP) solvent, or any combination of halogenated HAP solvents, in a total concentration greater than 5% by weight, as a cleaning and/or drying agent.	<input type="checkbox"/> YES <input checked="" type="checkbox"/> NO
2. The application area is located at a major source and includes solvent cleaning machines, qualifying as affected facilities, that use perchloroethylene, trichloroethylene or methylene chloride.	<input type="checkbox"/> YES <input checked="" type="checkbox"/> NO
3. The application area is located at an area source and includes solvent cleaning machines, other than cold batch cleaning machines, that use perchloroethylene, trichloroethylene or methylene chloride.	<input type="checkbox"/> YES <input checked="" type="checkbox"/> NO
J. Subpart U - National Emission Standards for Hazardous Air Pollutant Emissions: Group 1 Polymers and Resins	
1. The application area includes elastomer product process units and/or wastewater streams and wastewater operations that are associated with elastomer product process units. <i>If the response to Question VIII.J.1 is "NO," go to Section VIII.K.</i>	<input type="checkbox"/> YES <input checked="" type="checkbox"/> NO
2. Elastomer product process units and/or wastewater streams and wastewater operations located in the application area are subject to 40 CFR Part 63, Subpart U. <i>If the response to Question VIII.J.2 is "NO," go to Section VIII.K.</i>	<input type="checkbox"/> YES <input type="checkbox"/> NO
3. The application area includes process wastewater streams that are designated as Group 1 or are determined to be Group 1 for organic HAPs as defined in 40 CFR § 63.482.	<input type="checkbox"/> YES <input type="checkbox"/> NO
4. The application area includes process wastewater streams that are Group 2 for organic HAPs as defined in 40 CFR § 63.482.	<input type="checkbox"/> YES <input type="checkbox"/> NO

Texas Commission on Environmental Quality
Application Area-Wide Applicability Determinations and General Information
Form OP-REQ1
Federal Operating Permit Program

Date:	09/03/2024
Permit No.:	4119
RN No.:	RN109161745

For SOP applications, answer ALL questions unless otherwise directed.

◆ *For GOP applications, answer ONLY these questions unless otherwise directed.*

Form OP-REQ1: Page 45	
VIII. Title 40 Code of Federal Regulations Part 63 - National Emission Standards for Hazardous Air Pollutants for Source Categories (continued)	
J. Subpart U - National Emission Standards for Hazardous Air Pollutant Emissions: Group 1 Polymers and Resins (continued)	
5. All Group 1 wastewater streams at the site are demonstrated to have a total source mass flow rate of less than 1 MG/yr. <i>If the response to Question VIII.J.5 is "YES," go to Question VIII.J.15.</i>	<input type="checkbox"/> YES <input type="checkbox"/> NO
6. The site has untreated and/or partially treated Group 1 wastewater streams demonstrated to have a total source mass flow rate of less than 1 MG/yr. <i>If the response to Question VIII.J.6 is "NO," go to Question VIII.J.8.</i>	<input type="checkbox"/> YES <input type="checkbox"/> NO
7. The application area includes waste management units that receive or manage a partially treated Group 1 wastewater stream prior to or during treatment.	<input type="checkbox"/> YES <input type="checkbox"/> NO
8. Group 1 wastewater streams or residual removed from Group 1 wastewater streams are transferred to an on-site treatment operation that is not owned or operated by the owner or operator of the source generating the waste stream or residual.	<input type="checkbox"/> YES <input type="checkbox"/> NO
9. Group 1 wastewater streams or residual removed from Group 1 wastewater streams are transferred to an off-site treatment operation. <i>If the responses to Questions VIII.J.8 - VIII.J.9 are both "NO," go to Question VIII.J.11.</i>	<input type="checkbox"/> YES <input type="checkbox"/> NO
10. The application area includes waste management units that receive or manage a Group 1 wastewater stream, or a residual removed from a Group 1 wastewater stream prior to shipment or transport.	<input type="checkbox"/> YES <input type="checkbox"/> NO

Texas Commission on Environmental Quality
Application Area-Wide Applicability Determinations and General Information
Form OP-REQ1
Federal Operating Permit Program

Date:	09/03/2024
Permit No.:	4119
RN No.:	RN109161745

For SOP applications, answer ALL questions unless otherwise directed.

◆ *For GOP applications, answer ONLY these questions unless otherwise directed.*

Form OP-REQ1: Page 46	
VIII. Title 40 Code of Federal Regulations Part 63 - National Emission Standards for Hazardous Air Pollutants for Source Categories (continued)	
J. Subpart U - National Emission Standards for Hazardous Air Pollutant Emissions: Group 1 Polymers and Resins (continued)	
Containers	
11. The application area includes containers that receive, manage, or treat a Group 1 wastewater stream or a residual removed from a Group 1 wastewater stream.	<input type="checkbox"/> YES <input type="checkbox"/> NO
Drains	
12. The application area includes individual drain systems that receive or manage a Group 1 wastewater stream or a residual removed from a Group 1 wastewater stream. <i>If the response to Question VIII.J.12 is "NO," go to Question VIII.J.15.</i>	<input type="checkbox"/> YES <input type="checkbox"/> NO
13. The application area includes individual drain systems that are complying with 40 CFR § 63.136 through the use of cover and, if vented, closed vent systems and control devices.	<input type="checkbox"/> YES <input type="checkbox"/> NO
14. The application area includes individual drain systems that are complying with 40 CFR § 63.136 through the use of water seals or tightly fitting caps or plugs.	<input type="checkbox"/> YES <input type="checkbox"/> NO
15. The application area includes drains, drain hubs, manholes, lift stations, trenches, or pipes that are part of an elastomer product process unit. <i>If the response to Question VIII.J.15 is "NO," go to Section VIII.K.</i>	<input type="checkbox"/> YES <input type="checkbox"/> NO
16. The application area includes drains, drain hubs, manholes, lift stations, trenches or pipes that meet the criteria listed in 40 CFR § 63.149(d) and § 63.501(a)(12). <i>If the response to Question VIII.J.16 is "NO," go to Section VIII.K.</i>	<input type="checkbox"/> YES <input type="checkbox"/> NO

Texas Commission on Environmental Quality
Application Area-Wide Applicability Determinations and General Information
Form OP-REQ1
Federal Operating Permit Program

Date:	09/03/2024
Permit No.:	4119
RN No.:	RN109161745

For SOP applications, answer ALL questions unless otherwise directed.

◆ *For GOP applications, answer ONLY these questions unless otherwise directed.*

Form OP-REQ1: Page 47	
VIII. Title 40 Code of Federal Regulations Part 63 - National Emission Standards for Hazardous Air Pollutants for Source Categories (continued)	
J. Subpart U - National Emission Standards for Hazardous Air Pollutant Emissions: Group 1 Polymers and Resins (continued)	
Drains (continued)	
17. The application area includes drains, drain hubs, manholes, lift stations, trenches, or pipes that convey water with a total annual average concentration greater than or equal to 10,000 parts per million by weight of compounds meeting the definition of organic HAP in 40 CFR § 63.482, at any flow rate.	<input type="checkbox"/> YES <input type="checkbox"/> NO
18. The application area includes drains, drain hubs, manholes, lift stations, trenches or pipes that convey water with a total annual average concentration greater than or equal to 1,000 parts per million by weight of compounds meeting the definition of organic HAP in 40 CFR § 63.482, at an annual average flow rate greater than or equal to 10 liters per minute.	<input type="checkbox"/> YES <input type="checkbox"/> NO
19. The application area includes drains, drain hubs, manholes, lift stations, trenches or pipes that are part of an elastomer product process unit that is a new affected source or part of a new affected source and the equipment conveys water with a total annual average concentration greater than or equal to 10 parts per million by weight of compounds meeting the definition of organic HAP in 40 CFR § 63.482, at an average annual flow rate greater than or equal to 0.02 liter per minute.	<input type="checkbox"/> YES <input type="checkbox"/> NO
K. Subpart W - National Emission Standards for Hazardous Air Pollutants for Epoxy Resins Production and Non-nylon Polyamides Production	
1. The manufacture of basic liquid epoxy resins (BLR) and/or manufacture of wet strength resins (WSR) is conducted in the application area. <i>If the response to Question VIII.K.1 is "NO" or "N/A," go to Section VIII.L.</i>	<input type="checkbox"/> YES <input checked="" type="checkbox"/> NO <input type="checkbox"/> N/A
2. The application area includes a BLR and/or WSR research and development facility.	<input type="checkbox"/> YES <input type="checkbox"/> NO

Texas Commission on Environmental Quality
Application Area-Wide Applicability Determinations and General Information
Form OP-REQ1
Federal Operating Permit Program

Date:	09/03/2024
Permit No.:	4119
RN No.:	RN109161745

For SOP applications, answer ALL questions unless otherwise directed.

◆ *For GOP applications, answer ONLY these questions unless otherwise directed.*

Form OP-REQ1: Page 48	
VIII. Title 40 Code of Federal Regulations Part 63 - National Emission Standards for Hazardous Air Pollutants for Source Categories (continued)	
L. Subpart X - National Emission Standards for Hazardous Air Pollutants from Secondary Lead Smelting	
1. The application area includes one or more of the affected sources in 40 CFR § 63.541(a) that are located at a secondary lead smelter. <i>If the response to Question VIII.L.1 is "NO" or "N/A," go to Section VIII.M.</i>	<input type="checkbox"/> YES <input checked="" type="checkbox"/> NO <input type="checkbox"/> N/A
2. The application area is using and approved alternate to the requirements of § 63.545(c)(1)-(5) for control of fugitive dust emission sources.	<input type="checkbox"/> YES <input type="checkbox"/> NO
M. Subpart Y - National Emission Standards for Marine Tank Vessel Loading Operations	
1. The application area includes marine tank vessel loading operations that are specified in 40 CFR § 63.560 and located at an affected source as defined in 40 CFR § 63.561.	<input type="checkbox"/> YES <input checked="" type="checkbox"/> NO
N. Subpart CC - National Emission Standards for Hazardous Air Pollutants from Petroleum Refineries	
Applicability	
1. The application area includes petroleum refining process units and/or related emission points that are specified in 40 CFR § 63.640(c)(1) - (c)(7). <i>If the response to Question VIII.N.1 is "NO," go to Section VIII.O.</i>	<input type="checkbox"/> YES <input checked="" type="checkbox"/> NO
2. All petroleum refining process units/and or related emission points within the application area are specified in 40 CFR § 63.640(g)(1) - (g)(7). <i>If the response to Question VIII.N.2 is "YES," go to Section VIII.O.</i>	<input type="checkbox"/> YES <input type="checkbox"/> NO

Texas Commission on Environmental Quality
Application Area-Wide Applicability Determinations and General Information
Form OP-REQ1
Federal Operating Permit Program

Date:	09/03/2024
Permit No.:	4119
RN No.:	RN109161745

For SOP applications, answer ALL questions unless otherwise directed.

◆ *For GOP applications, answer ONLY these questions unless otherwise directed.*

Form OP-REQ1: Page 49	
VIII. Title 40 Code of Federal Regulations Part 63 - National Emission Standards for Hazardous Air Pollutants for Source Categories (continued)	
N. Subpart CC - National Emission Standards for Hazardous Air Pollutants from Petroleum Refineries (continued)	
Applicability (continued)	
3. The application area is located at a plant site that is a major source as defined in the Federal Clean Air Act § 112(a). <i>If the response to Question VIII.N.3 is "NO," go to Section VIII.O.</i>	<input type="checkbox"/> YES <input type="checkbox"/> NO
4. The application area is located at a plant site which emits or has equipment containing/contacting one or more of the HAPs listed in table 1 of 40 CFR Part 63, Subpart CC. <i>If the response to Question VIII.N.4 is "NO," go to Section VIII.O.</i>	<input type="checkbox"/> YES <input type="checkbox"/> NO
5. The application area includes Group 1 wastewater streams that are not conveyed, stored, or treated in a wastewater stream management unit that also receives streams subject to the provisions of 40 CFR §§ 63.133 - 63.147 of Subpart G wastewater provisions section.	<input type="checkbox"/> YES <input type="checkbox"/> NO
6. The application area includes Group 2 wastewater streams that are not conveyed, stored, or treated in a wastewater stream management unit that also receives streams subject to the provisions of 40 CFR §§ 63.133 - 63.147 of Subpart G wastewater provisions section.	<input type="checkbox"/> YES <input type="checkbox"/> NO
7. The application area includes Group 1 or Group 2 wastewater streams that are conveyed, stored, or treated in a wastewater stream management unit that also receives streams subject to the provisions of 40 CFR §§ 63.133 - 63.147 of Subpart G wastewater provisions section. <i>If the response to Question VIII.N.7 is "NO," go to Section VIII.O.</i>	<input type="checkbox"/> YES <input type="checkbox"/> NO
8. The application area includes Group 1 or Group 2 wastewater streams that are complying with 40 CFR § 63.640(o)(2)(i).	<input type="checkbox"/> YES <input type="checkbox"/> NO

Texas Commission on Environmental Quality
Application Area-Wide Applicability Determinations and General Information
Form OP-REQ1
Federal Operating Permit Program

Date:	09/03/2024
Permit No.:	4119
RN No.:	RN109161745

For SOP applications, answer ALL questions unless otherwise directed.

◆ *For GOP applications, answer ONLY these questions unless otherwise directed.*

Form OP-REQ1: Page 50	
VIII. Title 40 Code of Federal Regulations Part 63 - National Emission Standards for Hazardous Air Pollutants for Source Categories (continued)	
N. Subpart CC - National Emission Standards for Hazardous Air Pollutants from Petroleum Refineries (continued)	
Applicability (continued)	
9. The application area includes Group 1 or Group 2 wastewater streams that are complying with 40 CFR § 63.640(o)(2)(ii). <i>If the response to Question VIII.N.9 is "NO," go to Section VIII.O.</i>	<input type="checkbox"/> YES <input type="checkbox"/> NO
10. The application area includes Group 2 wastewater streams or organic streams whose benzene emissions are subject to control through the use of one or more treatment processes or waste management units under the provisions of 40 CFR Part 61, Subpart FF on or after December 31, 1992.	<input type="checkbox"/> YES <input type="checkbox"/> NO
Containers, Drains, and other Appurtenances	
11. The application area includes containers that are subject to the requirements of 40 CFR § 63.135 as a result of complying with 40 CFR § 63.640(o)(2)(ii).	<input type="checkbox"/> YES <input type="checkbox"/> NO
12. The application area includes individual drain systems that are subject to the requirements of 40 CFR § 63.136 as a result of complying with 40 CFR § 63.640(o)(2)(ii).	<input type="checkbox"/> YES <input type="checkbox"/> NO
O. Subpart DD - National Emission Standards for Off-site Waste and Recovery Operations	
1. The application area receives material that meets the criteria for off-site material as specified in 40 CFR § 63.680(b)(1). <i>If the response to Question VIII.O.1 is "NO" or "N/A," go to Section VIII.P</i>	<input type="checkbox"/> YES <input checked="" type="checkbox"/> NO <input type="checkbox"/> N/A
2. Materials specified in 40 CFR § 63.680(b)(2) are received at the application area.	<input type="checkbox"/> YES <input type="checkbox"/> NO
3. The application area has a waste management operation receiving off-site material and is regulated under 40 CFR Part 264 or Part 265.	<input type="checkbox"/> YES <input type="checkbox"/> NO

Texas Commission on Environmental Quality
Application Area-Wide Applicability Determinations and General Information
Form OP-REQ1
Federal Operating Permit Program

Date:	09/03/2024
Permit No.:	4119
RN No.:	RN109161745

For SOP applications, answer ALL questions unless otherwise directed.

◆ *For GOP applications, answer ONLY these questions unless otherwise directed.*

Form OP-REQ1: Page 51	
VIII. Title 40 Code of Federal Regulations Part 63 - National Emission Standards for Hazardous Air Pollutants for Source Categories (continued)	
O. Subpart DD - National Emission Standards for Off-site Waste and Recovery Operations (continued)	
4. The application area has a waste management operation treating wastewater which is an off-site material and is exempted under 40 CFR §§ 264.1(g)(6) or 265.1(c)(10).	<input type="checkbox"/> YES <input type="checkbox"/> NO
5. The application area has an operation subject to Clean Water Act, § 402 or § 307(b) but is not owned by a “state” or “municipality.”	<input type="checkbox"/> YES <input type="checkbox"/> NO
6. The predominant activity in the application area is the treatment of wastewater received from off-site.	<input type="checkbox"/> YES <input type="checkbox"/> NO
7. The application area has a recovery operation that recycles or reprocesses hazardous waste which is an off-site material and is exempted under 40 CFR §§ 264.1(g)(2) or 265.1(c)(6).	<input type="checkbox"/> YES <input type="checkbox"/> NO
8. The application area has a recovery operation that recycles or reprocesses used solvent which is an off-site material and is not part of a chemical, petroleum, or other manufacturing process that is required to use air emission controls by another subpart of 40 CFR Part 63 or Part 61.	<input type="checkbox"/> YES <input type="checkbox"/> NO
9. The application area has a recovery operation that re-refines or reprocesses used oil which is an off-site material and is regulated under 40 CFR Part 279, Subpart F (Standards for Used Oil Processors and Refiners).	<input type="checkbox"/> YES <input type="checkbox"/> NO
10. The application area is located at a site where the total annual quantity of HAPs in the off-site material is less than 1 megagram per year. <i>If the response to Question VIII.O.10 is “YES,” go to Section VIII.P.</i>	<input type="checkbox"/> YES <input type="checkbox"/> NO

Texas Commission on Environmental Quality
Application Area-Wide Applicability Determinations and General Information
Form OP-REQ1
Federal Operating Permit Program

Date:	09/03/2024
Permit No.:	4119
RN No.:	RN109161745

For SOP applications, answer ALL questions unless otherwise directed.

◆ *For GOP applications, answer ONLY these questions unless otherwise directed.*

Form OP-REQ1: Page 52	
VIII. Title 40 Code of Federal Regulations Part 63 - National Emission Standards for Hazardous Air Pollutants for Source Categories (continued)	
O. Subpart DD - National Emission Standards for Off-site Waste and Recovery Operations (continued)	
11. The application area receives offsite materials with average VOHAP concentration less than 500 ppmw at the point of delivery that are not combined with materials having a VOHAP concentration of 500 ppmw or greater. <i>If the response to Question VIII.O.11 is "NO," go to Question VIII.O.14.</i>	<input type="checkbox"/> YES <input type="checkbox"/> NO
12. VOHAP concentration is determined by direct measurement.	<input type="checkbox"/> YES <input type="checkbox"/> NO
13. VOHAP concentration is based on knowledge of the off-site material.	<input type="checkbox"/> YES <input type="checkbox"/> NO
14. The application area includes an equipment component that is a pump, compressor, and agitator, pressure relief device, sampling connection system, open-ended valve or line, valve, connector or instrumentation system. <i>If the response to Question VIII.O.14 is "NO," go to Question VIII.O.17.</i>	<input type="checkbox"/> YES <input type="checkbox"/> NO
15. An equipment component in the application area contains or contacts off-site material with a HAP concentration greater than or equal to 10% by weight.	<input type="checkbox"/> YES <input type="checkbox"/> NO
16. An equipment component in the application area is intended to operate 300 hours or more during a 12-month period.	<input type="checkbox"/> YES <input type="checkbox"/> NO
17. The application area includes containers that manage non-exempt off-site material.	<input type="checkbox"/> YES <input type="checkbox"/> NO
18. The application area includes individual drain systems that manage non-exempt off-site materials.	<input type="checkbox"/> YES <input type="checkbox"/> NO

Texas Commission on Environmental Quality
Application Area-Wide Applicability Determinations and General Information
Form OP-REQ1
Federal Operating Permit Program

Date:	09/03/2024
Permit No.:	4119
RN No.:	RN109161745

For SOP applications, answer ALL questions unless otherwise directed.

◆ *For GOP applications, answer ONLY these questions unless otherwise directed.*

Form OP-REQ1: Page 53	
VIII. Title 40 Code of Federal Regulations Part 63 - National Emission Standards for Hazardous Air Pollutants for Source Categories (continued)	
P. Subpart GG - National Emission Standards for Aerospace Manufacturing and Rework Facilities	
1. The application area includes facilities that manufacture or rework commercial, civil, or military aerospace vehicles or components. <i>If the response to Question VIII.P.1 is "NO" or "N/A," go to Section VIII.Q.</i>	<input type="checkbox"/> YES <input checked="" type="checkbox"/> NO <input type="checkbox"/> N/A
2. The application area includes one or more of the affected sources specified in 40 CFR § 63.741(c)(1) - (7).	<input type="checkbox"/> YES <input type="checkbox"/> NO
Q. Subpart HH - National Emission Standards for Hazardous Air Pollutants From Oil and Natural Gas Production Facilities.	
◆ 1. The application area contains facilities that process, upgrade or store hydrocarbon liquids that are located at oil and natural gas production facilities prior to the point of custody transfer.	<input checked="" type="checkbox"/> YES <input type="checkbox"/> NO
◆ 2. The application area contains facilities that process, upgrade or store natural gas prior to the point at which natural gas enters the natural gas transmission and storage source category or is delivered to a final end user. <i>For SOP applications, if the responses to Questions VIII.Q.1 and VIII.Q.2 are both "NO," go to Section VIII.R.</i> <i>For GOP applications, if the responses to Questions VIII.Q.1 and VIII.Q.2 are both "NO," go to Section VIII.Z.</i>	<input checked="" type="checkbox"/> YES <input type="checkbox"/> NO
◆ 3. The application area contains only facilities that exclusively process, store or transfer black oil as defined in § 63.761. <i>For SOP applications, if the response to Question VIII.Q.3 is "YES," go to Section VIII.R.</i> <i>For GOP applications, if the response to Question VIII.Q.3 is "YES," go to Section VIII.Z.</i>	<input type="checkbox"/> YES <input checked="" type="checkbox"/> NO
◆ 4. The application area is located at a site that is a major source of HAP. <i>If the response to Question VIII.Q.4 is "NO," go to Question VIII.Q.6.</i>	<input type="checkbox"/> YES <input checked="" type="checkbox"/> NO

Texas Commission on Environmental Quality
Application Area-Wide Applicability Determinations and General Information
Form OP-REQ1
Federal Operating Permit Program

Date:	09/03/2024
Permit No.:	4119
RN No.:	RN109161745

For SOP applications, answer ALL questions unless otherwise directed.

◆ *For GOP applications, answer ONLY these questions unless otherwise directed.*

Form OP-REQ1: Page 54	
VIII. Title 40 Code of Federal Regulations Part 63 - National Emission Standards for Hazardous Air Pollutants for Source Categories (continued)	
Q. Subpart - HH - National Emission Standards for Hazardous Air Pollutants From Oil and Natural Gas Production Facilities (continued)	
◆ 5. The application area contains only a facility, prior to the point of custody transfer, with facility-wide actual annual average natural gas throughput less than 18.4 thousand standard cubic meters (649,789.9 ft ³) per day and a facility-wide actual annual average hydrocarbon liquid throughput less than 39,700 liters (10,487.6 gallons) per day. <i>For SOP applications, if the response to Question VIII.Q.5 is "YES," go to Section VIII.R. For GOP applications, if the response to Question VIII.Q.5 is "YES," go to Section VIII.Z. For all applications, if the response to Question VIII.Q.5 is "NO," go to Question VIII.Q.9.</i>	<input type="checkbox"/> YES <input type="checkbox"/> NO
◆ 6. The application area includes a triethylene glycol (TEG) dehydration unit. <i>For SOP applications, if the answer to Question VIII.Q.6 is "NO," go to Section VIII.R. For GOP applications, if the response to Question VIII.Q.6 is "NO," go to Section VIII.Z.</i>	<input checked="" type="checkbox"/> YES <input type="checkbox"/> NO
◆ 7. The application area is located at a site that is within the boundaries of UA plus offset or a UC, as defined in 40 CFR § 63.761.	<input type="checkbox"/> YES <input checked="" type="checkbox"/> NO
◆ 8. The site has actual emissions of 5 tons per year or more of a single HAP, or 12.5 tons per year or more of a combination of HAP.	<input checked="" type="checkbox"/> YES <input type="checkbox"/> NO
◆ 9. Emissions for major source determination are being estimated based on the maximum natural gas or hydrocarbon liquid throughput as calculated in § 63.760(a)(1)(i)-(iii).	<input checked="" type="checkbox"/> YES <input type="checkbox"/> NO

Texas Commission on Environmental Quality
Application Area-Wide Applicability Determinations and General Information
Form OP-REQ1
Federal Operating Permit Program

Date:	09/03/2024
Permit No.:	4119
RN No.:	RN109161745

For SOP applications, answer ALL questions unless otherwise directed.

◆ *For GOP applications, answer ONLY these questions unless otherwise directed.*

Form OP-REQ1: Page 55	
VIII. Title 40 Code of Federal Regulations Part 63 - National Emission Standards for Hazardous Air Pollutants for Source Categories (continued)	
R. Subpart II - National Emission Standards for Shipbuilding and Ship Repair (Surface Coating)	
1. The application area includes shipbuilding or ship repair operations. <i>If the response to Question VIII.R.1 is "NO," go to Section VIII.S.</i>	<input type="checkbox"/> YES <input checked="" type="checkbox"/> NO
2. Shipbuilding or ship repair operations located in the application area are subject to 40 CFR Part 63, Subpart II.	<input type="checkbox"/> YES <input type="checkbox"/> NO
S. Subpart JJ - National Emission Standards for Wood Furniture Manufacturing Operations	
1. The application area includes wood furniture manufacturing operations and/or wood furniture component manufacturing operations. <i>If the response to Question VIII.S.1 is "NO" or "N/A," go to Section VIII.T.</i>	<input type="checkbox"/> YES <input checked="" type="checkbox"/> NO <input type="checkbox"/> N/A
2. The application area meets the definition of an "incidental wood manufacturer" as defined in 40 CFR § 63.801.	<input type="checkbox"/> YES <input type="checkbox"/> NO
T. Subpart KK - National Emission Standards for the Printing and Publishing Industry	
1. The application area includes publication rotogravure, product and packaging rotogravure, or wide-web flexographic printing presses.	<input type="checkbox"/> YES <input checked="" type="checkbox"/> NO <input type="checkbox"/> N/A
U. Subpart PP - National Emission Standards for Containers	
1. The application area includes containers for which another 40 CFR Part 60, 61, or 63 subpart references the use of 40 CFR Part 63, Subpart PP for the control of air emissions. <i>If the response to Question VIII.U.1 is "NO," go to Section VIII.V.</i>	<input type="checkbox"/> YES <input checked="" type="checkbox"/> NO
2. The application area includes containers using Container Level 1 controls.	<input type="checkbox"/> YES <input type="checkbox"/> NO
3. The application area includes containers using Container Level 2 controls.	<input type="checkbox"/> YES <input type="checkbox"/> NO

Texas Commission on Environmental Quality
Application Area-Wide Applicability Determinations and General Information
Form OP-REQ1
Federal Operating Permit Program

Date:	09/03/2024
Permit No.:	4119
RN No.:	RN109161745

For SOP applications, answer ALL questions unless otherwise directed.

◆ *For GOP applications, answer ONLY these questions unless otherwise directed.*

Form OP-REQ1: Page 56	
VIII. Title 40 Code of Federal Regulations Part 63 - National Emission Standards for Hazardous Air Pollutants for Source Categories (continued)	
U. Subpart PP - National Emission Standards for Containers (continued)	
4. The application area includes containers using Container Level 3 controls.	<input type="checkbox"/> YES <input type="checkbox"/> NO
V. Subpart RR - National Emission Standards for Individual Drain Systems	
1. The application area includes individual drain systems for which another 40 CFR Part 60, 61, or 63 subpart references the use of 40 CFR Part 63, Subpart RR for the control of air emissions.	<input type="checkbox"/> YES <input checked="" type="checkbox"/> NO
W. Subpart YY - National Emission Standards for Hazardous Air Pollutants for Source Categories - Generic Maximum Achievable Control Technology Standards	
1. The application area includes an acetal resins production process unit; an acrylic and modacrylic fiber production process unit complying with 40 CFR § 63.1103(b)(3)(i); or an existing polycarbonate production process.	<input type="checkbox"/> YES <input checked="" type="checkbox"/> NO
2. The application area includes process wastewater streams generated from an acetal resins production process unit; an acrylic and modacrylic fiber production process unit complying with 40 CFR § 63.1103(b)(3)(i); or an existing polycarbonate production process. <i>If the responses to Questions VIII.W.1 and VIII.W.2 are both "NO," go to Question VIII.W.20.</i>	<input type="checkbox"/> YES <input checked="" type="checkbox"/> NO
3. The application area includes process wastewater streams that are designated as Group 1 or are determined to be Group 1 under the requirements of 40 CFR § 63.132(c).	<input type="checkbox"/> YES <input type="checkbox"/> NO
4. The application area includes process wastewater streams that are determined to be Group 2 under the requirements of 40 CFR § 63.132(c).	<input type="checkbox"/> YES <input type="checkbox"/> NO
5. All Group 1 wastewater streams at the site are determined to have a total source mass flow rate of less than 1 MG/yr.	<input type="checkbox"/> YES <input type="checkbox"/> NO
6. The site has untreated and/or partially treated Group 1 wastewater streams demonstrated to have a total source mass flow rate of less than 1 MG/yr. <i>If the response to Question VIII.W.6 is "NO," go to Question VIII.W.8.</i>	<input type="checkbox"/> YES <input type="checkbox"/> NO

Texas Commission on Environmental Quality
Application Area-Wide Applicability Determinations and General Information
Form OP-REQ1
Federal Operating Permit Program

Date:	09/03/2024
Permit No.:	4119
RN No.:	RN109161745

For SOP applications, answer ALL questions unless otherwise directed.

◆ *For GOP applications, answer ONLY these questions unless otherwise directed.*

Form OP-REQ1: Page 57	
VIII. Title 40 Code of Federal Regulations Part 63 - National Emission Standards for Hazardous Air Pollutants for Source Categories (continued)	
W. Subpart YY - National Emission Standards for Hazardous Air Pollutants for Source Categories - Generic Maximum Achievable Control Technology Standards (continued)	
7. The application area includes waste management units that receive or manage a partially treated Group 1 wastewater stream prior to or during treatment.	<input type="checkbox"/> YES <input type="checkbox"/> NO
8. Group 1 wastewater streams or residual removed from Group 1 wastewater streams are transferred to an on-site treatment operation that is not owned or operated by the owner or operator of the source generating the waste stream or residual.	<input type="checkbox"/> YES <input type="checkbox"/> NO
9. Group 1 wastewater streams or residual removed from Group 1 wastewater streams are transferred to an off-site treatment operation. <i>If the responses to Questions VIII.W.8 and W.9 are both "NO," go to Question VIII.W.11.</i>	<input type="checkbox"/> YES <input type="checkbox"/> NO
10. The application area includes waste management units that receive or manage a Group 1 wastewater stream, or a residual removed from a Group 1 wastewater stream prior to shipment or transport.	<input type="checkbox"/> YES <input type="checkbox"/> NO
11. The application area includes containers that receive, manage, or treat a Group 1 wastewater stream or a residual removed from a Group 1 wastewater stream.	<input type="checkbox"/> YES <input type="checkbox"/> NO
12. The application area includes individual drain systems that receive, manage, or treat a Group 1 wastewater stream or a residual removed from a Group 1 wastewater stream. <i>If the response to Question VIII.W.12 is "NO," go to Question VIII.W.15.</i>	<input type="checkbox"/> YES <input type="checkbox"/> NO
13. The application area includes individual drain systems that are complying with 40 CFR § 63.136 through the use of covers and, if vented, closed vent systems and control devices.	<input type="checkbox"/> YES <input type="checkbox"/> NO
14. The application area includes individual drain systems that are complying with 40 CFR § 63.136 through the use of water seals or tightly fitting caps or plugs.	<input type="checkbox"/> YES <input type="checkbox"/> NO

Texas Commission on Environmental Quality
Application Area-Wide Applicability Determinations and General Information
Form OP-REQ1
Federal Operating Permit Program

Date:	09/03/2024
Permit No.:	4119
RN No.:	RN109161745

For SOP applications, answer ALL questions unless otherwise directed.

◆ *For GOP applications, answer ONLY these questions unless otherwise directed.*

Form OP-REQ1: Page 58	
VIII. Title 40 Code of Federal Regulations Part 63 - National Emission Standards for Hazardous Air Pollutants for Source Categories (continued)	
W. Subpart YY - National Emission Standards for Hazardous Air Pollutants for Source Categories - Generic Maximum Achievable Control Technology Standards (continued)	
15. The application area includes drains, drain hubs, manholes, lift stations, trenches, or pipes that are part of an acetal resins production process unit; an acrylic and modacrylic fiber production process unit complying with 40 CFR § 63.1103(b)(3)(i); or an existing polycarbonate production process unit. <i>If the response to Question VIII.W.15 is "NO," go to Question VIII.W.20.</i>	<input type="checkbox"/> YES <input type="checkbox"/> NO
16. The application area includes drains, drain hubs, manholes, lift stations, trenches or pipes that meet the criteria listed in 40 CFR § 63.1106(c)(1) - (3). <i>If the response to Question VIII.W.16 is "NO," go to Question VIII.W.20.</i>	<input type="checkbox"/> YES <input type="checkbox"/> NO
17. The application area includes drains, drain hubs, manholes, lift stations, trenches or pipes that convey water with a total annual average concentration greater than or equal to 10,000 parts per million by weight of compounds meeting the definition of organic HAP in Table 9 to 40 CFR Part 60, Subpart G, at any flow rate.	<input type="checkbox"/> YES <input type="checkbox"/> NO
18. The application area includes drains, drain hubs, manholes, lift stations, trenches or pipes that convey water with a total annual average concentration greater than or equal to 1,000 parts per million by weight of compounds meeting the definition of organic HAP in Table 9 to 40 CFR Part 60, Subpart G, at an annual average flow rate greater than or equal to 10 liters per minute.	<input type="checkbox"/> YES <input type="checkbox"/> NO

Texas Commission on Environmental Quality
Application Area-Wide Applicability Determinations and General Information
Form OP-REQ1
Federal Operating Permit Program

Date:	09/03/2024
Permit No.:	4119
RN No.:	RN109161745

For SOP applications, answer ALL questions unless otherwise directed.

◆ *For GOP applications, answer ONLY these questions unless otherwise directed.*

Form OP-REQ1: Page 59	
VIII. Title 40 Code of Federal Regulations Part 63 - National Emission Standards for Hazardous Air Pollutants for Source Categories (continued)	
W. Subpart YY - National Emission Standards for Hazardous Air Pollutants for Source Categories - Generic Maximum Achievable Control Technology Standards (continued)	
19. The application area includes drains, drain hubs, manholes, lift stations, trenches or pipes that are part of an acrylic resins or acrylic and modacrylic fiber production process unit that is part of a new affected source or is a new affected source and the equipment conveys water with a total annual average concentration greater than or equal to 10 ppmw of compounds meeting the definition of organic HAP in Table 9 to 40 CFR Part 60, Subpart G, at an average annual flow rate greater than or equal to 0.02 liter per minute.	<input type="checkbox"/> YES <input type="checkbox"/> NO
20. The application area includes an ethylene production process unit.	<input type="checkbox"/> YES <input checked="" type="checkbox"/> NO <input type="checkbox"/> N/A
21. The application area includes waste streams generated from an ethylene production process unit. <i>If the responses to Questions VIII.W.20 and VIII.W.21 are both "NO" or "N/A," go to Question VIII.W.54.</i>	<input type="checkbox"/> YES <input checked="" type="checkbox"/> NO <input type="checkbox"/> N/A
22. The waste stream(s) contains at least one of the chemicals listed in 40 CFR § 63.1103(e), Table 7(g)(1). <i>If the response to Question VIII.W.22 is "NO," go to Question VIII.W.54.</i>	<input type="checkbox"/> YES <input type="checkbox"/> NO
23. Waste stream(s) are transferred off-site for treatment. <i>If the response to Question VIII.W.23 is "NO," go to Question VIII.W.25.</i>	<input type="checkbox"/> YES <input type="checkbox"/> NO
24. The application area has waste management units that treat or manage waste stream(s) prior to transfer off-site for treatment. <i>If the response to Question VIII.W.24 is "NO," go to Question VIII.W.54.</i>	<input type="checkbox"/> YES <input type="checkbox"/> NO

Texas Commission on Environmental Quality
Application Area-Wide Applicability Determinations and General Information
Form OP-REQ1
Federal Operating Permit Program

Date:	09/03/2024
Permit No.:	4119
RN No.:	RN109161745

For SOP applications, answer ALL questions unless otherwise directed.

◆ *For GOP applications, answer ONLY these questions unless otherwise directed.*

Form OP-REQ1: Page 60	
VIII. Title 40 Code of Federal Regulations Part 63 - National Emission Standards for Hazardous Air Pollutants for Source Categories (continued)	
W. Subpart YY - National Emission Standards for Hazardous Air Pollutants for Source Categories - Generic Maximum Achievable Control Technology Standards (continued)	
25. The total annual benzene quantity from waste at the site is less than 10 Mg/yr as determined according to 40 CFR § 61.342(a).	<input type="checkbox"/> YES <input type="checkbox"/> NO
26. The application area contains at least one waste stream that is a continuous butadiene waste stream as defined in 40 CFR § 63.1082(b). <i>If the response to Question VIII.W.26 is "NO," go to Question VIII.W.43.</i>	<input type="checkbox"/> YES <input type="checkbox"/> NO
27. The waste stream(s) contains at least 10 ppmw 1, 3-butadiene at a flow rate of 0.02 liters per minute or is designated for control. <i>If the response to Question VIII.W.27 is "NO," go to Question VIII.W.43.</i>	<input type="checkbox"/> YES <input type="checkbox"/> NO
28. The control requirements of 40 CFR Part 63, Subpart G for process wastewater as specified in 40 CFR § 63.1095(a)(2) are selected for control of the waste stream(s). <i>If the response to Question VIII.W.28 is "NO," go to Question VIII.W.33.</i>	<input type="checkbox"/> YES <input type="checkbox"/> NO
29. The application area includes containers that receive, manage, or treat a continuous butadiene waste stream.	<input type="checkbox"/> YES <input type="checkbox"/> NO
30. The application area includes individual drain systems that receive, manage, or treat a continuous butadiene waste stream. <i>If the response to Question VIII.W.30 is "NO," go to Question VIII.W.43.</i>	<input type="checkbox"/> YES <input type="checkbox"/> NO
31. The application area includes individual drain systems that are complying with 40 CFR § 63.136 through the use of cover and, if vented, closed vent systems and control devices.	<input type="checkbox"/> YES <input type="checkbox"/> NO

Texas Commission on Environmental Quality
Application Area-Wide Applicability Determinations and General Information
Form OP-REQ1
Federal Operating Permit Program

Date:	09/03/2024
Permit No.:	4119
RN No.:	RN109161745

For SOP applications, answer ALL questions unless otherwise directed.

◆ *For GOP applications, answer ONLY these questions unless otherwise directed.*

Form OP-REQ1: Page 61	
VIII. Title 40 Code of Federal Regulations Part 63 - National Emission Standards for Hazardous Air Pollutants for Source Categories (continued)	
W. Subpart YY - National Emission Standards for Hazardous Air Pollutants for Source Categories - Generic Maximum Achievable Control Technology Standards (continued)	
32. The application area includes individual drain systems that are complying with 40 CFR § 63.136 through the use of water seals or tightly fitting caps or plugs. <i>If the response to Question VIII.W.32 is required, go to Question VIII.W.43.</i>	<input type="checkbox"/> YES <input type="checkbox"/> NO
33. The application area has containers, as defined in 40 CFR § 61.341, that receive a continuous butadiene waste stream. <i>If the response to Question VIII.W.33 is "NO," go to Question VIII.W.36.</i>	<input type="checkbox"/> YES <input type="checkbox"/> NO
34. The application area is an alternate means of compliance to meet the 40 CFR § 61.345 requirements for containers. <i>If the response to Question VIII.W.34 is "YES," go to Question VIII.W.36.</i>	<input type="checkbox"/> YES <input type="checkbox"/> NO
35. Covers and closed-vent systems used for containers operate such that the container is maintained at a pressure less than atmospheric pressure.	<input type="checkbox"/> YES <input type="checkbox"/> NO
36. The application area has individual drain systems, as defined in 40 CFR § 61.341, that receive or manage a continuous butadiene waste stream. <i>If the response to Question VIII.W.36 is "NO," go to Question VIII.W.43.</i>	<input type="checkbox"/> YES <input type="checkbox"/> NO
37. The application area is using an alternate means of compliance to meet the 40 CFR § 61.346 requirements for individual drain systems. <i>If the response to Question VIII.W.37 is "YES," go to Question VIII.W.43.</i>	<input type="checkbox"/> YES <input type="checkbox"/> NO

Texas Commission on Environmental Quality
Application Area-Wide Applicability Determinations and General Information
Form OP-REQ1
Federal Operating Permit Program

Date:	09/03/2024
Permit No.:	4119
RN No.:	RN109161745

For SOP applications, answer ALL questions unless otherwise directed.

◆ *For GOP applications, answer ONLY these questions unless otherwise directed.*

Form OP-REQ1: Page 62	
VIII. Title 40 Code of Federal Regulations Part 63 - National Emission Standards for Hazardous Air Pollutants for Source Categories (continued)	
W. Subpart YY - National Emission Standards for Hazardous Air Pollutants for Source Categories - Generic Maximum Achievable Control Technology Standards (continued)	
38. The application area has individual drain systems complying with 40 CFR § 61.346(a). <i>If the response to Question VIII.W.38 is "NO," go to Question VIII.W.40.</i>	<input type="checkbox"/> YES <input type="checkbox"/> NO
39. Covers and closed-vent systems used for individual drain systems operate such that the individual drain system is maintained at a pressure less than atmospheric pressure.	<input type="checkbox"/> YES <input type="checkbox"/> NO
40. The application area has individual drain systems complying with 40 CFR § 61.346(b). <i>If the response to Question VIII.W.40 is "NO," go to Question VIII.W.43.</i>	<input type="checkbox"/> YES <input type="checkbox"/> NO
41. Junction boxes in the individual drain systems are equipped with a system to prevent the flow of organic vapors from the junction box vent pipe to the atmosphere during normal operation.	<input type="checkbox"/> YES <input type="checkbox"/> NO
42. Junction box vent pipes in the individual drain systems are connected to a closed-vent system and control device.	<input type="checkbox"/> YES <input type="checkbox"/> NO
43. The application area has at least one waste stream that contains benzene. <i>If the response to Question VIII.W.43 is "NO," go to Question VIII.W.54.</i>	<input type="checkbox"/> YES <input type="checkbox"/> NO
44. The application area has containers, as defined in 40 CFR § 61.341, that receive a waste stream containing benzene. <i>If the response to Question VIII.W.44 is "NO," go to Question VIII.W.47.</i>	<input type="checkbox"/> YES <input type="checkbox"/> NO
45. The application area is an alternate means of compliance to meet the 40 CFR § 61.345 requirements for containers. <i>If the response to Question VIII.W.45 is "YES," go to Question VIII.W.47.</i>	<input type="checkbox"/> YES <input type="checkbox"/> NO

Texas Commission on Environmental Quality
Application Area-Wide Applicability Determinations and General Information
Form OP-REQ1
Federal Operating Permit Program

Date:	09/03/2024
Permit No.:	4119
RN No.:	RN109161745

For SOP applications, answer ALL questions unless otherwise directed.

◆ *For GOP applications, answer ONLY these questions unless otherwise directed.*

Form OP-REQ1: Page 63	
VIII. Title 40 Code of Federal Regulations Part 63 - National Emission Standards for Hazardous Air Pollutants for Source Categories (continued)	
W. Subpart YY - National Emission Standards for Hazardous Air Pollutants for Source Categories - Generic Maximum Achievable Control Technology Standards (continued)	
46. Covers and closed-vent systems used for containers operate such that the container is maintained at a pressure less than atmospheric pressure.	<input type="checkbox"/> YES <input type="checkbox"/> NO
47. The application area has individual drain systems, as defined in 40 CFR § 61.341, that receive or manage a waste stream containing benzene. <i>If the response to Question VIII.W.47 is "NO," go to Question VIII.W.54.</i>	<input type="checkbox"/> YES <input type="checkbox"/> NO
48. The application area is using an alternate means of compliance to meet the 40 CFR § 61.346 requirements for individual drain systems. <i>If the response to Question VIII.W.48 is "YES," go to Question VIII.W.54.</i>	<input type="checkbox"/> YES <input type="checkbox"/> NO
49. The application area has individual drain systems complying with 40 CFR § 61.346(a). <i>If the response to Question VIII.W.49 is "NO," go to Question VIII.W.51.</i>	<input type="checkbox"/> YES <input type="checkbox"/> NO
50. Covers and closed-vent systems used for individual drain systems operate such that the individual drain system is maintained at a pressure less than atmospheric pressure.	<input type="checkbox"/> YES <input type="checkbox"/> NO
51. The application area has individual drain systems complying with 40 CFR § 61.346(b). <i>If the response to Question VIII.W.51 is "NO," go to Question VIII.W.54.</i>	<input type="checkbox"/> YES <input type="checkbox"/> NO
52. Junction boxes in the individual drain systems are equipped with a system to prevent the flow of organic vapors from the junction box vent pipe to the atmosphere during normal operation.	<input type="checkbox"/> YES <input type="checkbox"/> NO

Texas Commission on Environmental Quality
Application Area-Wide Applicability Determinations and General Information
Form OP-REQ1
Federal Operating Permit Program

Date:	09/03/2024
Permit No.:	4119
RN No.:	RN109161745

For SOP applications, answer ALL questions unless otherwise directed.

◆ *For GOP applications, answer ONLY these questions unless otherwise directed.*

Form OP-REQ1: Page 64	
VIII. Title 40 Code of Federal Regulations Part 63 - National Emission Standards for Hazardous Air Pollutants for Source Categories (continued)	
W. Subpart YY - National Emission Standards for Hazardous Air Pollutants for Source Categories - Generic Maximum Achievable Control Technology Standards (continued)	
53. Junction box vent pipes in the individual drain systems are connected to a closed-vent system and control device.	<input type="checkbox"/> YES <input type="checkbox"/> NO
54. The application area contains a cyanide chemicals manufacturing process. <i>If the response to Question VIII.W.54 is "NO," go to Section VIII.X.</i>	<input type="checkbox"/> YES <input checked="" type="checkbox"/> NO
55. The cyanide chemicals manufacturing process generates maintenance wastewater containing hydrogen cyanide or acetonitrile.	<input type="checkbox"/> YES <input type="checkbox"/> NO
X. Subpart JJJ - National Emission Standards for Hazardous Air Pollutant Emissions: Group IV Polymers and Resins	
1. The application area includes thermoplastic product process units, and/or their associated affected sources specified in 40 CFR § 63.1310(a)(1) - (5), that are subject to 40 CFR Part 63, Subpart JJJ. <i>If the response to Question VIII.X.1 is "NO," go to Section VIII.Y.</i>	<input type="checkbox"/> YES <input checked="" type="checkbox"/> NO
2. The application area includes thermoplastic product process units and/or wastewater streams and wastewater operations that are associated with thermoplastic product process units. <i>If the response to Question VIII.X.2 is "NO," go to Section VIII.Y.</i>	<input type="checkbox"/> YES <input type="checkbox"/> NO
3. All process wastewater streams generated or managed in the application area are from sources producing polystyrene. <i>If the response to Question VIII.X.3 is "YES," go to Section VIII.Y.</i>	<input type="checkbox"/> YES <input type="checkbox"/> NO
4. All process wastewater streams generated or managed in the application area are from sources producing ASA/AMSAN. <i>If the response to Question VIII.X.4 is "YES," go to Section VIII.Y.</i>	<input type="checkbox"/> YES <input type="checkbox"/> NO

Texas Commission on Environmental Quality
Application Area-Wide Applicability Determinations and General Information
Form OP-REQ1
Federal Operating Permit Program

Date:	09/03/2024
Permit No.:	4119
RN No.:	RN109161745

For SOP applications, answer ALL questions unless otherwise directed.

◆ *For GOP applications, answer ONLY these questions unless otherwise directed.*

Form OP-REQ1: Page 65	
VIII. Title 40 Code of Federal Regulations Part 63 - National Emission Standards for Hazardous Air Pollutants for Source Categories (continued)	
X. Subpart JJJ - National Emission Standards for Hazardous Air Pollutant Emissions: Group IV Polymers and Resins (continued)	
5. The application area includes process wastewater streams that are designated as Group 1 or are determined to be Group 1 for organic HAPs as defined in 40 CFR § 63.1312.	<input type="checkbox"/> YES <input type="checkbox"/> NO
6. The application area includes process wastewater streams, located at existing sources, that are Group 2 for organic HAPs as defined in 40 CFR § 63.1312.	<input type="checkbox"/> YES <input type="checkbox"/> NO
7. The application area includes process wastewater streams, located at new sources, that are Group 2 for organic HAPs as defined in 40 CFR § 63.1312.	<input type="checkbox"/> YES <input type="checkbox"/> NO
8. All Group 1 wastewater streams at the site are demonstrated to have a total source mass flow rate of less than 1 MG/yr. <i>If the response to Question VIII.X.8 is "YES," go to Question VIII.X.18.</i>	<input type="checkbox"/> YES <input type="checkbox"/> NO
9. The site has untreated and/or partially treated Group 1 wastewater streams demonstrated to have a total source mass flow rate of less than 1 MG/yr. <i>If the response to Question VIII.X.9 is "NO," go to Question VIII.X.11.</i>	<input type="checkbox"/> YES <input type="checkbox"/> NO
10. The application area includes waste management units that receive or manage a partially treated Group 1 wastewater stream prior to or during treatment.	<input type="checkbox"/> YES <input type="checkbox"/> NO
11. Group 1 wastewater streams or residual removed from Group 1 wastewater streams are transferred to an on-site treatment operation that is not owned or operated by the owner or operator of the source generating the waste stream or residual.	<input type="checkbox"/> YES <input type="checkbox"/> NO
12. Group 1 wastewater streams or residual removed from Group 1 wastewater streams are transferred to an off-site treatment operation. <i>If the responses to Questions VIII.X.11 - VIII.X.12 are both "NO," go to Question VIII.X.14.</i>	<input type="checkbox"/> YES <input type="checkbox"/> NO

Texas Commission on Environmental Quality
Application Area-Wide Applicability Determinations and General Information
Form OP-REQ1
Federal Operating Permit Program

Date:	09/03/2024
Permit No.:	4119
RN No.:	RN109161745

For SOP applications, answer ALL questions unless otherwise directed.

◆ *For GOP applications, answer ONLY these questions unless otherwise directed.*

Form OP-REQ1: Page 66	
VIII. Title 40 Code of Federal Regulations Part 63 - National Emission Standards for Hazardous Air Pollutants for Source Categories (continued)	
X. Subpart JJJ - National Emission Standards for Hazardous Air Pollutant Emissions: Group IV Polymers and Resins (continued)	
13. The application area includes waste management units that receive or manage a Group 1 wastewater stream, or a residual removed from a Group 1 wastewater stream prior to shipment or transport.	<input type="checkbox"/> YES <input type="checkbox"/> NO
Containers	
14. The application area includes containers that receive, manage, or treat a Group 1 wastewater stream or a residual removed from a Group 1 wastewater stream.	<input type="checkbox"/> YES <input type="checkbox"/> NO
Drains	
15. The application area includes individual drain systems that receive or manage a Group 1 wastewater stream or a residual removed from a Group 1 wastewater stream. <i>If the response to Question VIII.X.15 is "NO," go to Question VIII.X.18.</i>	<input type="checkbox"/> YES <input type="checkbox"/> NO
16. The application area includes individual drain systems that are complying with 40 CFR § 63.136 through the use of cover and, if vented, closed vent systems and control devices.	<input type="checkbox"/> YES <input type="checkbox"/> NO
17. The application area includes individual drain systems that are complying with 40 CFR § 63.136 through the use of water seals or tightly fitting caps or plugs.	<input type="checkbox"/> YES <input type="checkbox"/> NO
18. The application area includes drains, drain hubs, manholes, lift stations, trenches, or pipes that are part of a thermoplastic product process unit. <i>If the response to Question VIII.X.18 is "NO," go to Section VIII.Y.</i>	<input type="checkbox"/> YES <input type="checkbox"/> NO

Texas Commission on Environmental Quality
Application Area-Wide Applicability Determinations and General Information
Form OP-REQ1
Federal Operating Permit Program

Date:	09/03/2024
Permit No.:	4119
RN No.:	RN109161745

For SOP applications, answer ALL questions unless otherwise directed.

◆ *For GOP applications, answer ONLY these questions unless otherwise directed.*

Form OP-REQ1: Page 67	
VIII. Title 40 Code of Federal Regulations Part 63 - National Emission Standards for Hazardous Air Pollutants for Source Categories (continued)	
X. Subpart JJJ - National Emission Standards for Hazardous Air Pollutant Emissions: Group IV Polymers and Resins (continued)	
Drains (continued)	
19. The application area includes drains, drain hubs, manholes, lift stations, trenches or pipes that meet the criteria listed in 40 CFR § 63.149(d) and § 63.1330(b)(12). <i>If the response to Question VIII.X.19 is "NO," go to Section VIII.Y.</i>	<input type="checkbox"/> YES <input type="checkbox"/> NO
20. The application area includes drains, drain hubs, manholes, lift stations, trenches, or pipes that convey water with a total annual average concentration greater than or equal to 10,000 parts per million by weight of compounds meeting the definition of organic HAP in 40 CFR § 63.1312, at any flow rate.	<input type="checkbox"/> YES <input type="checkbox"/> NO
21. The application area includes drains, drain hubs, manholes, lift stations, trenches or pipes that convey water with a total annual average concentration greater than or equal to 1,000 parts per million by weight of compounds meeting the definition of organic HAP in 40 CFR § 63.1312, at an annual average flow rate greater than or equal to 10 liters per minute.	<input type="checkbox"/> YES <input type="checkbox"/> NO
22. The application area includes drains, drain hubs, manholes, lift stations, trenches or pipes that are part of an thermoplastic product process unit that is a new affected source or part of a new affected source and the equipment conveys water with a total annual average concentration greater than or equal to 10 parts per million by weight of compounds meeting the definition of organic HAP in 40 CFR § 63.1312, at an average annual flow rate greater than or equal to 0.02 liter per minute	<input type="checkbox"/> YES <input type="checkbox"/> NO

Texas Commission on Environmental Quality
Application Area-Wide Applicability Determinations and General Information
Form OP-REQ1
Federal Operating Permit Program

Date:	09/03/2024
Permit No.:	4119
RN No.:	RN109161745

For SOP applications, answer ALL questions unless otherwise directed.

◆ *For GOP applications, answer ONLY these questions unless otherwise directed.*

Form OP-REQ1: Page 68	
VIII. Title 40 Code of Federal Regulations Part 63 - National Emission Standards for Hazardous Air Pollutants for Source Categories (continued)	
Y. Subpart UUU - National Emission Standards for Hazardous Air Pollutants for Petroleum Refineries: Catalytic Cracking Units, Catalytic reforming Units, and Sulfur Recovery Units.	
1. The application area is subject to 40 CFR Part 63, Subpart UUU - National Emission Standards for Hazardous Air Pollutants for Petroleum Refineries: Catalytic Cracking Units, Catalytic reforming Units, and Sulfur Recovery Units.	<input type="checkbox"/> YES <input checked="" type="checkbox"/> NO
Z. Subpart AAAA - National Emission Standards for Hazardous Air Pollutants for Municipal Solid Waste (MSW) Landfills.	
◆ 1. The application area is subject to 40 CFR Part 63, Subpart AAAA - National Emission Standards for Hazardous Air Pollutants for Municipal Solid Waste Landfills.	<input type="checkbox"/> YES <input checked="" type="checkbox"/> NO
AA. Subpart FFFF - National Emission Standards for Hazardous Air Pollutants for Miscellaneous Organic Chemical Production and Processes (MON)	
1. The application area is located at a site that includes process units that manufacture as a primary product one or more of the chemicals listed in 40 CFR § 63.2435(b)(1).	<input type="checkbox"/> YES <input checked="" type="checkbox"/> NO
2. The application area is located at a plant site that is a major source as defined in FCAA § 112(a).	<input type="checkbox"/> YES <input checked="" type="checkbox"/> NO
3. The application area is located at a site that includes miscellaneous chemical manufacturing process units (MCPU) that process, use or generate one or more of the organic hazardous air pollutants listed in § 112(b) of the Clean Air Act or hydrogen halide and halogen HAP. <i>If the response to Question VIII.AA.1, AA.2 or AA.3 is "NO," go to Section VIII.BB.</i>	<input type="checkbox"/> YES <input checked="" type="checkbox"/> NO
4. The application area includes process vents, storage vessels, transfer racks, or waste streams associated with a miscellaneous chemical manufacturing process subject to 40 CFR 63, Subpart FFFF. <i>If the response to Question VIII.AA.4 is "NO," go to Section VIII.BB.</i>	<input type="checkbox"/> YES <input type="checkbox"/> NO

Texas Commission on Environmental Quality
Application Area-Wide Applicability Determinations and General Information
Form OP-REQ1
Federal Operating Permit Program

Date:	09/03/2024
Permit No.:	4119
RN No.:	RN109161745

For SOP applications, answer ALL questions unless otherwise directed.

◆ *For GOP applications, answer ONLY these questions unless otherwise directed.*

Form OP-REQ1: Page 69	
VIII. Title 40 Code of Federal Regulations Part 63 - National Emission Standards for Hazardous Air Pollutants for Source Categories (continued)	
AA. Subpart FFFF - National Emission Standards for Hazardous Air Pollutants for Miscellaneous Organic Chemical Production and Processes (MON) (continued)	
5. The application area includes process wastewater streams. <i>If the response to Question VIII.AA.5 is "NO," go to Question VIII.AA.18.</i>	<input type="checkbox"/> YES <input type="checkbox"/> NO
6. The application area includes process wastewater streams that are designated as Group 1 or are determined to be Group 1 for compounds listed in Table 8 of 40 CFR Part 63, Subpart G or Table 8 and Table 9, as appropriate, of 40 CFR Part 63, Subpart FFFF.	<input type="checkbox"/> YES <input type="checkbox"/> NO
7. The application area includes process wastewater streams that are Group 2 for compounds listed in Table 8 or Table 8 and Table 9, as appropriate, of 40 CFR Part 63, Subpart FFFF.	<input type="checkbox"/> YES <input type="checkbox"/> NO
8. All Group 1 wastewater streams at the site are demonstrated to have a total source mass flow rate of less than 1 MG/yr. <i>If the response to Question VIII.AA.8 is "YES," go to Section VIII.AA.22.</i>	<input type="checkbox"/> YES <input type="checkbox"/> NO
9. The site has untreated and/or partially treated Group 1 wastewater streams demonstrated to have a total source mass flow rate of less than 1 MG/yr. <i>If the response to Question VIII.AA.9 is "NO," go to Question VIII.AA.11.</i>	<input type="checkbox"/> YES <input type="checkbox"/> NO
10. The application area includes waste management units that receive or manage a partially treated Group 1 wastewater stream prior to or during treatment.	<input type="checkbox"/> YES <input type="checkbox"/> NO
11. Group 1 wastewater streams or residual removed from Group 1 wastewater streams are transferred to an on-site treatment operation that is not owned or operated by the owner or operator of the source generating the waste stream or residual.	<input type="checkbox"/> YES <input type="checkbox"/> NO
12. Group 1 wastewater streams or residual removed from Group 1 wastewater streams are transferred to an off-site treatment operation. <i>If the responses to Questions VIII.AA.11 and VIII.AA.12 are both "NO," go to Question VIII.AA.18.</i>	<input type="checkbox"/> YES <input type="checkbox"/> NO

Texas Commission on Environmental Quality
Application Area-Wide Applicability Determinations and General Information
Form OP-REQ1
Federal Operating Permit Program

Date:	09/03/2024
Permit No.:	4119
RN No.:	RN109161745

For SOP applications, answer ALL questions unless otherwise directed.

◆ *For GOP applications, answer ONLY these questions unless otherwise directed.*

Form OP-REQ1: Page 70	
VIII. Title 40 Code of Federal Regulations Part 63 - National Emission Standards for Hazardous Air Pollutants for Source Categories (continued)	
AA. Subpart FFFF - National Emission Standards for Hazardous Air Pollutants for Miscellaneous Organic Chemical Production and Processes (MON) (continued)	
13. Group 1 wastewater streams are transferred to an offsite treatment facility meeting the requirements of 40 CFR § 63.138(h). <i>If the response to Question VIII.AA.13 is "NO," go to Question VIII.AA.15.</i>	<input type="checkbox"/> YES <input type="checkbox"/> NO
14. The option to document in the notification of compliance status report that the wastewater will be treated in a facility meeting the requirements of 40 CFR § 63.138(h) is elected.	<input type="checkbox"/> YES <input type="checkbox"/> NO
15. Group 1 wastewater streams or residuals with a total annual average concentration of compounds in Table 8 of 40 CFR Part 63, Subpart FFFF less than 50 ppmw are transferred offsite. <i>If the response to Question VIII.AA.15 is "NO," go to Question VIII.AA.17.</i>	<input type="checkbox"/> YES <input type="checkbox"/> NO
16. The transferor is demonstrating that less than 5 percent of the HAP in Table 9 of 40 CFR Part 63, Subpart FFFF is emitted from waste management units up to the activated sludge unit.	<input type="checkbox"/> YES <input type="checkbox"/> NO
17. The application area includes waste management units that receive or manage a Group 1 wastewater stream, or a residual removed from a Group 1 wastewater stream prior to shipment or transport.	<input type="checkbox"/> YES <input type="checkbox"/> NO
18. The application area includes containers that receive, manage, or treat a Group 1 wastewater stream or a residual removed from a Group 1 wastewater stream.	<input type="checkbox"/> YES <input type="checkbox"/> NO
19. The application area includes individual drain systems that receive or manage a Group 1 wastewater stream, or a residual removed from a Group 1 wastewater stream. <i>If the response to Question VIII.AA.19 is "NO," go to Question VIII.AA.22.</i>	<input type="checkbox"/> YES <input type="checkbox"/> NO
20. The application area includes individual drain systems that are complying with 40 CFR § 63.136 through the use of cover and, if vented, closed vent systems and control devices.	<input type="checkbox"/> YES <input type="checkbox"/> NO

Texas Commission on Environmental Quality
Application Area-Wide Applicability Determinations and General Information
Form OP-REQ1
Federal Operating Permit Program

Date:	09/03/2024
Permit No.:	4119
RN No.:	RN109161745

For SOP applications, answer ALL questions unless otherwise directed.

◆ *For GOP applications, answer ONLY these questions unless otherwise directed.*

Form OP-REQ1: Page 71	
VIII. Title 40 Code of Federal Regulations Part 63 - National Emission Standards for Hazardous Air Pollutants for Source Categories (continued)	
AA. Subpart FFFF - National Emission Standards for Hazardous Air Pollutants for Miscellaneous Organic Chemical Production and Processes (MON) (continued)	
21. The application area includes individual drain systems that are complying with 40 CFR § 63.136 through the use of water seals or tightly fitting caps or plugs.	<input type="checkbox"/> YES <input type="checkbox"/> NO
22. The application area includes drains, drain hubs, manholes, lift stations, trenches, or pipes that are part of a chemical manufacturing process unit that meets the criteria of 40 CFR § 63.100(b). <i>If the response to Question VIII.AA.22 is "NO," go to Section VIII.BB.</i>	<input type="checkbox"/> YES <input type="checkbox"/> NO
23. The application area includes drains, drain hubs, manholes, lift stations, trenches or pipes (that are part of a miscellaneous chemical manufacturing process unit) that meet the criteria listed in 40 CFR § 63.149(d). <i>If the response to Question VIII.AA.23 is "NO," go to Section VIII.BB.</i>	<input type="checkbox"/> YES <input type="checkbox"/> NO
24. The application area includes drains, drain hubs, manholes, lift stations, trenches or pipes that convey water with a total annual average concentration of compounds in table 8 of 40 CFR Part 63, Subpart FFFF is greater than or equal to 10,000 ppmw at any flow rate, and the total annual load of compounds in table 8 of 40 CFR Part 63, Subpart FFFF is greater than or equal to 200 lb/yr.	<input type="checkbox"/> YES <input type="checkbox"/> NO
25. The application area includes drains, drain hubs, manholes, lift stations, trenches, or pipes that convey water with a total annual average concentration of compounds in table 8 of 40 CFR Part 63, Subpart FFFF is greater than or equal to 1,000 ppmw, and the annual average flow rate is greater than or equal to 1 liter per minute.	<input type="checkbox"/> YES <input type="checkbox"/> NO
26. The application area includes drains, drain hubs, manholes, lift stations, trenches or pipes that are part of a chemical manufacturing process unit that is subject to the new source requirements of 40 CFR § 63.2445(a); and the equipment conveys water with a combined total annual average concentration of compounds in tables 8 and 9 of 40 CFR Part 63, Subpart FFFF is greater than or equal to 30,000 ppmw, and the combined total annual load of compounds in tables 8 and 9 to this subpart is greater than or equal to 1 tpy.	<input type="checkbox"/> YES <input type="checkbox"/> NO

Texas Commission on Environmental Quality
Application Area-Wide Applicability Determinations and General Information
Form OP-REQ1
Federal Operating Permit Program

Date:	09/03/2024
Permit No.:	4119
RN No.:	RN109161745

For SOP applications, answer ALL questions unless otherwise directed.

◆ *For GOP applications, answer ONLY these questions unless otherwise directed.*

Form OP-REQ1: Page 72	
VIII. Title 40 Code of Federal Regulations Part 63 - National Emission Standards for Hazardous Air Pollutants for Source Categories (continued)	
AA. Subpart FFFF - National Emission Standards for Hazardous Air Pollutants for Miscellaneous Organic Chemical Production and Processes (MON) (continued)	
BB. Subpart GGGG - National Emission Standards for Hazardous Air Pollutants for: Solvent Extractions for Vegetable Oil Production.	
1. The application area includes a vegetable oil production process that: is by itself a major source of HAP emissions or, is collocated within a plant site with other sources that are individually or collectively a major source of HAP emissions.	<input type="checkbox"/> YES <input checked="" type="checkbox"/> NO
CC. Subpart GGGGG - National Emission Standards for Hazardous Air Pollutants: Site Remediation	
1. The application area includes a facility at which a site remediation is conducted. <i>If the answer to Question VIII.CC.1 is "NO," go to Section VIII.DD.</i>	<input type="checkbox"/> YES <input checked="" type="checkbox"/> NO
2. The application area is located at a site that is a major source of HAP. <i>If the answer to Question VIII.CC.2 is "NO," go to Section VIII.DD.</i>	<input type="checkbox"/> YES <input type="checkbox"/> NO
3. All site remediation's qualify for one of the exemptions contained in 40 CFR § 63.7881(b)(1) through (6). <i>If the answer to Question VIII.CC.3 is "YES," go to Section VIII.DD.</i>	<input type="checkbox"/> YES <input type="checkbox"/> NO
4. Prior to beginning site remediation activities it was determined that the total quantity of HAP listed in Table 1 of Subpart GGGGG that will be removed during all site remediations will be less than 1 Mg/yr. <i>If the answer to Question VIII.CC.4 is "YES," go to Section VIII.DD.</i>	<input type="checkbox"/> YES <input type="checkbox"/> NO
5. The site remediation will be completed within 30 consecutive calendar days.	<input type="checkbox"/> YES <input type="checkbox"/> NO
6. No site remediation will exceed 30 consecutive calendar days. <i>If the answer to Question VIII.CC.6 is "YES," go to Section VIII.DD.</i>	<input type="checkbox"/> YES <input type="checkbox"/> NO
7. Site remediation materials subject to 40 CFR Part 63, Subpart GGGGG are transferred from the application area to an off-site facility.	<input type="checkbox"/> YES <input type="checkbox"/> NO
8. All site remediation materials subject to 40 CFR Part 63, Subpart GGGGG are transferred from the application area to an off-site facility. <i>If the answer to Question VIII.CC.8 is "YES," go to Section VIII.DD.</i>	<input type="checkbox"/> YES <input type="checkbox"/> NO

Texas Commission on Environmental Quality
Application Area-Wide Applicability Determinations and General Information
Form OP-REQ1
Federal Operating Permit Program

Date:	09/03/2024
Permit No.:	4119
RN No.:	RN109161745

For SOP applications, answer ALL questions unless otherwise directed.

◆ *For GOP applications, answer ONLY these questions unless otherwise directed.*

Form OP-REQ1: Page 73	
VIII. Title 40 Code of Federal Regulations Part 63 - National Emission Standards for Hazardous Air Pollutants for Source Categories (continued)	
CC. Subpart GGGGG - National Emission Standards for Hazardous Air Pollutants: Site Remediation (continued)	
9. The application area includes containers that manage site remediation materials subject to 40 CFR Part 63, Subpart GGGGG. <i>If the response to Question VIII.CC.9 is "NO," go to Question VIII.CC.14.</i>	<input type="checkbox"/> YES <input type="checkbox"/> NO
10. The application area includes containers using Container Level 1 controls as specified in 40 CFR § 63.922(b).	<input type="checkbox"/> YES <input type="checkbox"/> NO
11. The application area includes containers with a capacity greater than 0.46 m ³ that meet the requirements of 40 CFR § 63.7900(b)(3)(i) and (ii).	<input type="checkbox"/> YES <input type="checkbox"/> NO
12. The application area includes containers using Container Level 2 controls as specified in 40 CFR § 63.923(b).	<input type="checkbox"/> YES <input type="checkbox"/> NO
13. The application area includes containers using Container Level 3 controls as specified in 40 CFR § 63.924(b).	<input type="checkbox"/> YES <input type="checkbox"/> NO
14. The application area includes individual drain systems complying with the requirements of 40 CFR § 63.962.	<input type="checkbox"/> YES <input type="checkbox"/> NO
DD. Subpart YYYYY - National Emission Standards for Hazardous Air Pollutants for Area/Sources: Electric Arc Furnace Steelmaking Facilities	
1. The application area includes an electric arc furnace (EAF) steelmaking facility, and the site is an area source of hazardous air pollutant (HAP) emissions. <i>If the response to Question VIII.DD.1 is "NO," go to Section VIII.EE.</i>	<input type="checkbox"/> YES <input checked="" type="checkbox"/> NO
2. The EAF steelmaking facility is a research and development facility. <i>If the response to Question VIII.DD.2 is "YES," go to Section VIII.EE.</i>	<input type="checkbox"/> YES <input type="checkbox"/> NO
3. Metallic scrap is utilized in the EAF.	<input type="checkbox"/> YES <input type="checkbox"/> NO
4. Scrap containing motor vehicle scrap is utilized in the EAF.	<input type="checkbox"/> YES <input type="checkbox"/> NO
5. Scrap not containing motor vehicle scrap is utilized in the EAF.	<input type="checkbox"/> YES <input type="checkbox"/> NO

Texas Commission on Environmental Quality
Application Area-Wide Applicability Determinations and General Information
Form OP-REQ1
Federal Operating Permit Program

Date:	09/03/2024
Permit No.:	4119
RN No.:	RN109161745

For SOP applications, answer ALL questions unless otherwise directed.

◆ *For GOP applications, answer ONLY these questions unless otherwise directed.*

Form OP-REQ1: Page 74	
VIII. Title 40 Code of Federal Regulations Part 63 - National Emission Standards for Hazardous Air Pollutants for Source Categories (continued)	
EE. Subpart BBBB - National Emission Standards for Hazardous Air Pollutants for Source Category: Gasoline Distribution Bulk Terminals, Bulk Plants and Pipeline Facilities	
1. The application area is located at a site that is an area source of HAPs. <i>If the answer to Question EE.1 is "NO," go to Section VIII.FF.</i>	<input checked="" type="checkbox"/> YES <input type="checkbox"/> NO
2. The application area includes a pipeline breakout station, as defined in 40 CFR Part 63, Subpart BBBB, not subject to the control requirements of 40 CFR Part 63, Subpart R.	<input type="checkbox"/> YES <input checked="" type="checkbox"/> NO
3. The application area includes a pipeline pumping station as defined in 40 CFR Part 63, Subpart BBBB.	<input type="checkbox"/> YES <input checked="" type="checkbox"/> NO
4. The application area includes a bulk gasoline plant as defined in 40 CFR Part 63, Subpart BBBB. <i>If the answer to Question VIII.EE.4 is "NO," go to Question VIII.EE.6.</i>	<input type="checkbox"/> YES <input checked="" type="checkbox"/> NO
5. The bulk gasoline plant was operating, prior to January 10, 2010, in compliance with an enforceable State, local or tribal rule or permit that requires submerged fill as specified in 40 CFR § 63.11086(a).	<input type="checkbox"/> YES <input type="checkbox"/> NO
6. The application area includes a bulk gasoline terminal, as defined in 40 CFR Part 63, Subpart BBBB, not subject to the control requirements of 40 CFR Part 63, Subpart R or Subpart CC. <i>If the answer to Question VIII.EE.6 is "NO," go to Section VIII.FF.</i>	<input type="checkbox"/> YES <input checked="" type="checkbox"/> NO
7. The bulk gasoline terminal has throughput of less than 250,000 gallons per day. <i>If the answer to Question VIII.EE.7 is "YES," go to Section VIII.FF.</i>	<input type="checkbox"/> YES <input type="checkbox"/> NO
8. The bulk gasoline terminal loads gasoline into gasoline cargo tanks other than railcar cargo tanks.	<input type="checkbox"/> YES <input type="checkbox"/> NO
9. The bulk gasoline terminal loads gasoline into railcar cargo tanks. <i>If the answer to Question VIII.EE.9 is "NO," go to Section VIII.FF.</i>	<input type="checkbox"/> YES <input type="checkbox"/> NO
10. The bulk gasoline terminal loads gasoline into railcar cargo tanks which do not collect vapors from a vapor balance system.	<input type="checkbox"/> YES <input type="checkbox"/> NO

Texas Commission on Environmental Quality
Application Area-Wide Applicability Determinations and General Information
Form OP-REQ1
Federal Operating Permit Program

Date:	09/03/2024
Permit No.:	4119
RN No.:	RN109161745

For SOP applications, answer ALL questions unless otherwise directed.

◆ *For GOP applications, answer ONLY these questions unless otherwise directed.*

Form OP-REQ1: Page 75	
VIII. Title 40 Code of Federal Regulations Part 63 - National Emission Standards for Hazardous Air Pollutants for Source Categories (continued)	
EE. Subpart BBBB - National Emission Standards for Hazardous Air Pollutants for Source Category: Gasoline Distribution Bulk Terminals, Bulk Plants and Pipeline Facilities (continued)	
11. The bulk gasoline terminal loads gasoline into railcar cargo tanks which collect vapors from a vapor balance system and that system complies with a Federal, State, local, tribal rule or permit.	<input type="checkbox"/> YES <input type="checkbox"/> NO
FF. Subpart CCCCC - National Emission Standards for Hazardous Air Pollutants for Source Category: Gasoline Dispensing Facilities	
◆ 1. The application area is located at a site that is an area source of hazardous air pollutants. <i>If the answer to Question VIII.FF.1 is "NO," go to Section VIII.GG.</i>	<input checked="" type="checkbox"/> YES <input type="checkbox"/> NO
◆ 2. The application area includes at least one gasoline dispensing facility as defined in 40 CFR § 63.11132. <i>If the answer to Question VIII.FF.2 is "NO," go to Section VIII.GG.</i>	<input type="checkbox"/> YES <input checked="" type="checkbox"/> NO
◆ 3. The application area includes at least one gasoline dispensing facility with a monthly throughput of less than 10,000 gallons.	<input type="checkbox"/> YES <input type="checkbox"/> NO
◆ 4. The application area includes at least one gasoline dispensing facility where gasoline is dispensed from a fixed gasoline storage tank into a portable gasoline tank for the on-site delivery and subsequent dispensing into other gasoline-fueled equipment.	<input type="checkbox"/> YES <input type="checkbox"/> NO
GG. Recently Promulgated 40 CFR Part 63 Subparts	
◆ 1. The application area is subject to one or more promulgated 40 CFR Part 63 subparts not addressed on this form. <i>If the response to Question VIII.GG.1 is "NO," go to Section IX. A list of promulgated 40 CFR Part 63 subparts not otherwise addressed on OP-REQ1 is included in the instructions.</i>	<input checked="" type="checkbox"/> YES <input type="checkbox"/> NO
◆ 2. Provide the Subpart designation (i.e. Subpart EEE) in the space provided below. 40 CFR 63 Subpart ZZZZ	

Texas Commission on Environmental Quality
Application Area-Wide Applicability Determinations and General Information
Form OP-REQ1
Federal Operating Permit Program

Date:	09/03/2024
Permit No.:	4119
RN No.:	RN109161745

For SOP applications, answer ALL questions unless otherwise directed.

◆ *For GOP applications, answer ONLY these questions unless otherwise directed.*

Form OP-REQ1: Page 76	
IX. Title 40 Code of Federal Regulations Part 68 (40 CFR Part 68) - Chemical Accident Prevention Provisions	
A. Applicability	
◆ 1. The application area contains processes subject to 40 CFR Part 68, Chemical Accident Prevention Provisions, and specified in 40 CFR § 68.10.	<input checked="" type="checkbox"/> YES <input type="checkbox"/> NO
X. Title 40 Code of Federal Regulations Part 82 (40 CFR Part 82) - Protection of Stratospheric Ozone	
A. Subpart A - Production and Consumption Controls	
◆ 1. The application area is located at a site that produces, transforms, destroys, imports, or exports a controlled substance or product.	<input type="checkbox"/> YES <input checked="" type="checkbox"/> NO <input type="checkbox"/> N/A
B. Subpart B - Servicing of Motor Vehicle Air Conditioners	
◆ 1. Servicing, maintenance, and/or repair of fleet vehicle air conditioning systems using ozone-depleting refrigerants is conducted in the application area.	<input type="checkbox"/> YES <input checked="" type="checkbox"/> NO
C. Subpart C - Ban on Nonessential Products Containing Class I Substances and Ban on Nonessential Products Containing or Manufactured with Class II Substances	
◆ 1. The application area sells or distributes one or more nonessential products (which release a Class I or Class II substance) that are subject to 40 CFR Part 82, Subpart C.	<input type="checkbox"/> YES <input checked="" type="checkbox"/> NO <input type="checkbox"/> N/A
D. Subpart D - Federal Procurement	
◆ 1. The application area is owned/operated by a department, agency, or instrumentality of the United States.	<input type="checkbox"/> YES <input checked="" type="checkbox"/> NO <input type="checkbox"/> N/A
E. Subpart E - The Labeling of Products Using Ozone Depleting Substances	
◆ 1. The application area includes containers in which a Class I or Class II substance is stored or transported prior to the sale of the Class I or Class II substance to the ultimate consumer.	<input type="checkbox"/> YES <input checked="" type="checkbox"/> NO <input type="checkbox"/> N/A
◆ 2. The application area is a manufacturer, importer, wholesaler, distributor, or retailer of products containing a Class I or Class II substance.	<input type="checkbox"/> YES <input checked="" type="checkbox"/> NO <input type="checkbox"/> N/A
◆ 3. The application area is a manufacturer, importer, wholesaler, distributor, or retailer of products manufactured with a process that uses a Class I or Class II substance.	<input type="checkbox"/> YES <input checked="" type="checkbox"/> NO <input type="checkbox"/> N/A

Texas Commission on Environmental Quality
Application Area-Wide Applicability Determinations and General Information
Form OP-REQ1
Federal Operating Permit Program

Date:	09/03/2024
Permit No.:	4119
RN No.:	RN109161745

For SOP applications, answer ALL questions unless otherwise directed.

◆ *For GOP applications, answer ONLY these questions unless otherwise directed.*

Form OP-REQ1: Page 77	
X. Title 40 Code of Federal Regulations Part 82 (40 CFR Part 82) - Protection of Stratospheric Ozone (continued)	
F. Subpart F - Recycling and Emissions Reduction	
◆ 1. Servicing, maintenance, and/or repair on refrigeration and non-motor vehicle air condition appliances using ozone-depleting refrigerants or non-exempt substitutes is conducted in the application area.	<input type="checkbox"/> YES <input checked="" type="checkbox"/> NO
◆ 2. Disposal of appliances (including motor vehicle air conditioners) or refrigerant or non-exempt substitute reclamation occurs in the application area.	<input type="checkbox"/> YES <input checked="" type="checkbox"/> NO <input type="checkbox"/> N/A
◆ 3. The application area manufactures appliances or refrigerant recycling and recovery equipment.	<input type="checkbox"/> YES <input checked="" type="checkbox"/> NO <input type="checkbox"/> N/A
G. Subpart G - Significant New Alternatives Policy Program	
◆ 1. The application area manufactures, formulates, or creates chemicals, product substitutes, or alternative manufacturing processes that are intended for use as a replacement for a Class I or Class II compound. <i>If the response to Question X.G.1 is "NO" or "N/A," go to Section X.H.</i>	<input type="checkbox"/> YES <input checked="" type="checkbox"/> NO <input type="checkbox"/> N/A
◆ 2. All substitutes produced by the application area meet one or more of the exemptions in 40 CFR § 82.176(b)(1) - (7).	<input type="checkbox"/> YES <input type="checkbox"/> NO <input type="checkbox"/> N/A
H. Subpart H -Halon Emissions Reduction	
◆ 1. Testing, servicing, maintaining, repairing, or disposing of equipment containing halons is conducted in the application area.	<input type="checkbox"/> YES <input checked="" type="checkbox"/> NO <input type="checkbox"/> N/A
◆ 2. Disposal of halons or manufacturing of halon blends is conducted in the application area.	<input type="checkbox"/> YES <input type="checkbox"/> NO <input type="checkbox"/> N/A
XI. Miscellaneous	
A. Requirements Reference Tables (RRT) and Flowcharts	
1. The application area contains units that are potentially subject to a regulation for which the TCEQ has not developed an RRT and flowchart.	<input type="checkbox"/> YES <input checked="" type="checkbox"/> NO

Texas Commission on Environmental Quality
Application Area-Wide Applicability Determinations and General Information
Form OP-REQ1
Federal Operating Permit Program

Date:	09/03/2024
Permit No.:	4119
RN No.:	RN109161745

For SOP applications, answer ALL questions unless otherwise directed.

◆ *For GOP applications, answer ONLY these questions unless otherwise directed.*

Form OP-REQ1: Page 78	
XI. Miscellaneous (continued)	
B. Forms	
◆ 1. The application area contains units that are potentially subject to a regulation for which the TCEQ has not developed a unit attribute form. <i>If the response to Question XI.B.1 is "NO" or "N/A," go to Section XI.C.</i>	<input type="checkbox"/> YES <input checked="" type="checkbox"/> NO <input type="checkbox"/> N/A
◆ 2. Provide the Part and Subpart designation for the federal rule(s) or the Chapter, Subchapter, and Division designation for the State regulation(s) in the space provided below.	
C. Emission Limitation Certifications	
◆ 1. The application area includes units for which federally enforceable emission limitations have been established by certification.	<input checked="" type="checkbox"/> YES <input type="checkbox"/> NO
D. Alternative Means of Control, Alternative Emission Limitation or Standard, or Equivalent Requirements	
1. The application area is located at a site that is subject to a site-specific requirement of the state implementation plan (SIP).	<input type="checkbox"/> YES <input checked="" type="checkbox"/> NO
2. The application area includes units located at the site that are subject to a site-specific requirement of the SIP.	<input type="checkbox"/> YES <input checked="" type="checkbox"/> NO
3. The application area includes units which demonstrate compliance by using an alternative means of control, alternative emission limitation or standard or equivalent requirements approved by the EPA Administrator. <i>If the response to Question XI.D.3 is "YES," please include a copy of the approval document with the application.</i>	<input type="checkbox"/> YES <input checked="" type="checkbox"/> NO
4. The application area includes units which demonstrate compliance by using an alternative means of control, alternative emission limitation or standard or equivalent requirements approved by the TCEQ Executive Director. <i>If the response to Question XI.D.4 is "YES," please include a copy of the approval document with the application.</i>	<input type="checkbox"/> YES <input checked="" type="checkbox"/> NO

Texas Commission on Environmental Quality
Application Area-Wide Applicability Determinations and General Information
Form OP-REQ1
Federal Operating Permit Program

Date:	09/03/2024
Permit No.:	4119
RN No.:	RN109161745

For SOP applications, answer ALL questions unless otherwise directed.

◆ *For GOP applications, answer ONLY these questions unless otherwise directed.*

Form OP-REQ1: Page 79	
XI. Miscellaneous (continued)	
E. Title IV - Acid Rain Program	
1. The application area includes emission units subject to the Acid Rain Program (ARP), including the Opt-In Program.	<input type="checkbox"/> YES <input checked="" type="checkbox"/> NO
2. The application area includes emission units qualifying for the new unit exemption under 40 CFR § 72.7.	<input type="checkbox"/> YES <input checked="" type="checkbox"/> NO
3. The application area includes emission units qualifying for the retired unit exemption under 40 CFR § 72.8.	<input type="checkbox"/> YES <input checked="" type="checkbox"/> NO
F. 40 CFR Part 97, Subpart EEEEE - Cross-State Air Pollution Rule (CSAPR) NO_x Ozone Season Group 2 Trading Program	
1. The application area includes emission units subject to the requirements of the CSAPR NO _x Ozone Season Group 2 Trading Program. <i>If the response to Question XI.F.1 is "NO," go to Question XI.F.7.</i>	<input type="checkbox"/> YES <input checked="" type="checkbox"/> NO
2. The application area includes units that are complying with the CEMS requirements of 40 CFR Part 75, Subpart H for NO _x and heat input.	<input type="checkbox"/> YES <input type="checkbox"/> NO
3. The application area includes gas or oil-fired units that are complying with the CEMS requirements of 40 CFR Part 75, Subpart H for NO _x , and the monitoring requirements of 40 CFR Part 75, Appendix D for heat input.	<input type="checkbox"/> YES <input type="checkbox"/> NO
4. The application area includes gas or oil-fired peaking units that are complying with the monitoring requirements of 40 CFR Part 75, Appendix E for NO _x , and the monitoring requirements of 40 CFR Part 75, Appendix D for heat input.	<input type="checkbox"/> YES <input type="checkbox"/> NO
5. The application area includes gas or oil-fired units that are complying with the Low Mass Emissions monitoring requirements of 40 CFR § 75.19 for NO _x and heat input.	<input type="checkbox"/> YES <input type="checkbox"/> NO
6. The application area includes units that are complying with EPA-approved alternative monitoring system requirements of 40 CFR Part 75, Subpart E for NO _x and heat input.	<input type="checkbox"/> YES <input type="checkbox"/> NO
7. The application area includes emission units that qualify for the CSAPR NO _x Ozone Season Group 2 retired unit exemption.	<input type="checkbox"/> YES <input checked="" type="checkbox"/> NO

Texas Commission on Environmental Quality
Application Area-Wide Applicability Determinations and General Information
Form OP-REQ1
Federal Operating Permit Program

Date:	09/03/2024
Permit No.:	4119
RN No.:	RN109161745

For SOP applications, answer ALL questions unless otherwise directed.

◆ *For GOP applications, answer ONLY these questions unless otherwise directed.*

Form OP-REQ1: Page 80	
XI. Miscellaneous (continued)	
G. 40 CFR Part 97, Subpart FFFFF - Texas SO₂ Trading Program	
1. The application area includes emission units complying with the requirements of the Texas SO ₂ Trading Program. <i>If the response to Question XI.G.1 is "NO," go to Question XI.G.6.</i>	<input type="checkbox"/> YES <input checked="" type="checkbox"/> NO
2. The application area includes units that are complying with the CEMS requirements of 40 CFR Part 75, Subpart B for SO ₂ and 40 CFR Part 75, Subpart H for heat input.	<input type="checkbox"/> YES <input type="checkbox"/> NO
3. The application area includes gas or oil-fired units that are complying with the monitoring requirements of 40 CFR Part 75, Appendix D for SO ₂ and heat input.	<input type="checkbox"/> YES <input type="checkbox"/> NO
4. The application area includes gas or oil-fired units that are complying with the Low Mass Emissions monitoring requirements of 40 CFR § 75.19 for SO ₂ and heat input.	<input type="checkbox"/> YES <input type="checkbox"/> NO
5. The application area includes units that are complying with EPA-approved alternative monitoring system requirements of 40 CFR Part 75, Subpart E for SO ₂ and heat input.	<input type="checkbox"/> YES <input type="checkbox"/> NO
6. The application area includes emission units that qualify for the Texas SO ₂ Trading Program retired unit exemption.	<input type="checkbox"/> YES <input checked="" type="checkbox"/> NO
H. Permit Shield (SOP Applicants Only)	
1. A permit shield for negative applicability entries on Form OP-REQ2 (Negative Applicable Requirement Determinations) is being requested or already exists in the permit.	<input checked="" type="checkbox"/> YES <input type="checkbox"/> NO

Texas Commission on Environmental Quality
Application Area-Wide Applicability Determinations and General Information
Form OP-REQ1
Federal Operating Permit Program

Date:	09/03/2024
Permit No.:	4119
RN No.:	RN109161745

For SOP applications, answer ALL questions unless otherwise directed.

◆ *For GOP applications, answer ONLY these questions unless otherwise directed.*

Form OP-REQ1: Page 81	
XI. Miscellaneous (continued)	
I. GOP Type (Complete this section for GOP applications only)	
◆ 1. The application area is applying for initial issuance, revision, or renewal of an oil and gas general operating permit under GOP No. 511 - Oil and Gas General Operating Permit for Brazoria, Chambers, Collin, Dallas, Denton, El Paso, Ellis, Fort Bend, Galveston, Hardin, Harris, Jefferson, Johnson, Kaufman, Liberty, Montgomery, Orange, Parker, Rockwall, Tarrant, Waller, and Wise Counties.	<input type="checkbox"/> YES <input type="checkbox"/> NO
◆ 2. The application area is applying for initial issuance, revision, or renewal of an oil and gas general operating permit under GOP No. 512 - Oil and Gas General Operating Permit for Gregg, Nueces, and Victoria Counties.	<input type="checkbox"/> YES <input type="checkbox"/> NO
◆ 3. The application area is applying for initial issuance, revision, or renewal of an oil and gas general operating permit under GOP No. 513 - Oil and Gas General Operating Permit for Aransas, Bexar, Calhoun, Matagorda, San Patricio, and Travis Counties.	<input type="checkbox"/> YES <input type="checkbox"/> NO
◆ 4. The application area is applying for initial issuance, revision, or renewal of an oil and gas general operating permit under GOP No. 514 - Oil and Gas General Operating Permit for All Texas Counties Except Aransas, Bexar, Brazoria, Calhoun, Chambers, Collin, Dallas, Denton, El Paso, Ellis, Fort Bend, Galveston, Gregg, Hardin, Harris, Jefferson, Johnson, Kaufman, Liberty, Matagorda, Montgomery, Nueces, Orange, Parker, Rockwall, San Patricio, Tarrant, Travis, Victoria, Waller, and Wise County.	<input type="checkbox"/> YES <input type="checkbox"/> NO
◆ 5. The application area is applying for initial issuance, revision, or renewal of a solid waste landfill general operating permit under GOP No. 517 - Municipal Solid Waste Landfill general operating permit.	<input type="checkbox"/> YES <input type="checkbox"/> NO
J. Title 30 TAC Chapter 101, Subchapter H	
◆ 1. The application area is located in a nonattainment area. <i>If the response to Question XI.J.1 is "NO," go to question XI.J.3.</i>	<input type="checkbox"/> YES <input checked="" type="checkbox"/> NO
◆ 2. The applicant has or will generate emission reductions to be credited in the TCEQ Emissions Banking and Trading Program.	<input type="checkbox"/> YES <input type="checkbox"/> NO <input type="checkbox"/> N/A
◆ 3. The applicant has or will generate discrete emission reductions to be credited in the TCEQ Emissions Banking and Trading Program.	<input type="checkbox"/> YES <input checked="" type="checkbox"/> NO <input type="checkbox"/> N/A

Texas Commission on Environmental Quality
Application Area-Wide Applicability Determinations and General Information
Form OP-REQ1
Federal Operating Permit Program

Date:	09/03/2024
Permit No.:	4119
RN No.:	RN109161745

For SOP applications, answer ALL questions unless otherwise directed.

◆ *For GOP applications, answer ONLY these questions unless otherwise directed.*

Form OP-REQ1: Page 82		
XI. Miscellaneous (continued)		
J. Title 30 TAC Chapter 101, Subchapter H (continued)		
◆	4. The application area is located at a site in the Houston/Galveston/Brazoria nonattainment area where the facilities have a collective uncontrolled design capacity to emit 10 tpy or more of NO _x .	<input type="checkbox"/> YES <input checked="" type="checkbox"/> NO
◆	5. The application area includes an electric generating facility permitted under 30 TAC Chapter 116, Subchapter I.	<input type="checkbox"/> YES <input checked="" type="checkbox"/> NO
◆	6. The application area is located at a site in the Houston/Galveston/Brazoria nonattainment area and the site has a potential to emit more than 10 tpy of highly-reactive volatile organic compounds (HRVOC) from facilities covered under 30 TAC Chapter 115, Subchapter H, Divisions 1 and 2.	<input type="checkbox"/> YES <input checked="" type="checkbox"/> NO
◆	7. The application area is located at a site in the Houston/Galveston/Brazoria nonattainment area, the site has a potential to emit 10 tpy or less of HRVOC from covered facilities and the applicant is opting to comply with the requirements of 30 TAC Chapter 101, Subchapter H, Division 6, Highly Reactive VOC Emissions Cap and Trade Program.	<input type="checkbox"/> YES <input checked="" type="checkbox"/> NO
K. Periodic Monitoring		
◆	1. The applicant or permit holder is submitting at least one periodic monitoring proposal described on Form OP-MON in this application.	<input type="checkbox"/> YES <input checked="" type="checkbox"/> NO
◆	2. The permit currently contains at least one periodic monitoring requirement. <i>If the responses to Questions XI.K.1 and XI.K.2 are both "NO," go to Section XI.L.</i>	<input type="checkbox"/> YES <input checked="" type="checkbox"/> NO
◆	3. All periodic monitoring requirements are being removed from the permit with this application.	<input type="checkbox"/> YES <input type="checkbox"/> NO

Texas Commission on Environmental Quality
Application Area-Wide Applicability Determinations and General Information
Form OP-REQ1
Federal Operating Permit Program

Date:	09/03/2024
Permit No.:	4119
RN No.:	RN109161745

For SOP applications, answer ALL questions unless otherwise directed.

◆ *For GOP applications, answer ONLY these questions unless otherwise directed.*

Form OP-REQ1: Page 83	
XI. Miscellaneous (continued)	
L. Compliance Assurance Monitoring	
◆ 1. The application area includes at least one unit that does not meet the CAM exemptions in 40 CFR § 64.2(b) for all applicable requirements that it is subject to, and the unit has a pre-control device potential to emit greater than or equal to the amount in tons per year required in a site classified as a major source. <i>If the response to Question XI.L.1 is "NO," go to Section XI.M.</i>	<input checked="" type="checkbox"/> YES <input type="checkbox"/> NO
◆ 2. The unit or units defined by XI.L.1 are using a control device to comply with an applicable requirement. <i>If the response to Question XI.L.2 is "NO," go to Section XI.M.</i>	<input checked="" type="checkbox"/> YES <input type="checkbox"/> NO
◆ 3. The permit holder has submitted a CAM proposal on Form OP-MON in a previous application.	<input checked="" type="checkbox"/> YES <input type="checkbox"/> NO
◆ 4. The owner/operator or permit holder is submitting a CAM proposal on Form OP-MON according to the deadlines for submittals in 40 CFR § 64.5 in this application. <i>If the responses to Questions XI.L.3 and XI.L.4 are both "NO," go to Section XI.M.</i>	<input type="checkbox"/> YES <input checked="" type="checkbox"/> NO
5. The owner/operator or permit holder is submitting a CAM implementation plan and schedule to be incorporated as enforceable conditions in the permit.	<input type="checkbox"/> YES <input type="checkbox"/> NO
6. Provide the unit identification numbers for the units for which the applicant is submitting a CAM implementation plan and schedule in the space below.	
◆ 7. At least one unit defined by XI.L.1 and XI.L.2 is using a CEMS, COMS or PEMS meeting the requirements of 40 CFR § 64.3(d)(2).	<input type="checkbox"/> YES <input type="checkbox"/> NO
◆ 8. All units defined by XI.L.1 and XI.L.2 are using a CEMS, COMS or PEMS meeting the requirements of 40 CFR § 64.3(d)(2). <i>If the response to Question XI.L.8 is "YES," go to Section XI.M.</i>	<input type="checkbox"/> YES <input type="checkbox"/> NO

Texas Commission on Environmental Quality
Application Area-Wide Applicability Determinations and General Information
Form OP-REQ1
Federal Operating Permit Program

Date:	09/03/2024
Permit No.:	4119
RN No.:	RN109161745

For SOP applications, answer ALL questions unless otherwise directed.

◆ *For GOP applications, answer ONLY these questions unless otherwise directed.*

Form OP-REQ1: Page 84	
XI. Miscellaneous (continued)	
L. Compliance Assurance Monitoring (continued)	
◆ 9. At least one of the CAM proposals as described by question XI.L.3 or XI.L.4 addresses particulate matter, and the emission unit has a capture system as defined in 40 CFR §64.1.	<input type="checkbox"/> YES <input type="checkbox"/> NO
◆ 10. At least one of the CAM proposals as described by question XI.L.3 or XI.L.4 addresses VOC, and the emission unit has a capture system as defined in 40 CFR §64.1.	<input type="checkbox"/> YES <input type="checkbox"/> NO
◆ 11. At least one of the CAM proposals as described by question XI.L.3 or XI.L.4 addresses a regulated pollutant other than particulate matter or VOC, and the emission unit has a capture system as defined in 40 CFR §64.1.	<input type="checkbox"/> YES <input type="checkbox"/> NO
◆ 12. The control device in the CAM proposal as described by question XI.L.3 or XI.L.4 has a bypass.	<input type="checkbox"/> YES <input type="checkbox"/> NO
M. Title 30 TAC Chapter 113, Subchapter D, Division 5 - Emission Guidelines and Compliance Times	
◆ 1. The application area includes at least one air curtain incinerator that commenced construction on or before December 9, 2004. <i>If the response to Question XI.M.1 is "NO," or "N/A," go to Section XII.</i>	<input type="checkbox"/> YES <input checked="" type="checkbox"/> NO <input type="checkbox"/> N/A
◆ 2. All air curtain incinerators constructed on or before December 9, 2004 combust only wood waste, clean lumber, or yard waste or a mixture of these materials.	<input type="checkbox"/> YES <input type="checkbox"/> NO
XII. New Source Review (NSR) Authorizations	
A. Waste Permits with Air Addendum	
◆ 1. The application area includes a Municipal Solid Waste Permit or an Industrial Hazardous Waste with an Air Addendum. <i>If the response to XII.A.1 is "YES," include the waste permit numbers and issuance date in Section XII.J.</i>	<input type="checkbox"/> YES <input checked="" type="checkbox"/> NO

Texas Commission on Environmental Quality
Application Area-Wide Applicability Determinations and General Information
Form OP-REQ1
Federal Operating Permit Program

Date:	09/03/2024
Permit No.:	4119
RN No.:	RN109161745

For SOP applications, answer ALL questions unless otherwise directed.

◆ *For GOP applications, answer ONLY these questions unless otherwise directed.*

Form OP-REQ1: Page 85		
XII. New Source Review (NSR) Authorizations (continued)		
B. Air Quality Standard Permits		
◆	1. The application area includes at least one Air Quality Standard Permit NSR authorization. <i>If the response to XII.B.1 is "NO," go to Section XII.C. If the response to XII.B.1 is "YES," be sure to include the standard permit's registration numbers in Section XII.H and answer XII.B.2 - B.16 as appropriate.</i>	<input checked="" type="checkbox"/> YES <input type="checkbox"/> NO
◆	2. The application area includes at least one "State Pollution Control Project" Air Quality Standard Permit NSR authorization under 30 TAC § 116.617.	<input type="checkbox"/> YES <input checked="" type="checkbox"/> NO
◆	3. The application area includes at least one non-rule Air Quality Standard Permit for Pollution Control Projects NSR authorization.	<input type="checkbox"/> YES <input checked="" type="checkbox"/> NO
◆	4. The application area includes at least one "Installation and/or Modification of Oil and Gas Facilities" Air Quality Standard Permit NSR authorization under 30 TAC § 116.620.	<input checked="" type="checkbox"/> YES <input type="checkbox"/> NO
◆	5. The application area includes at least one non-rule Air Quality Standard Permit for Oil and Gas Handling and Production Facilities NSR authorization.	<input type="checkbox"/> YES <input checked="" type="checkbox"/> NO
◆	6. The application area includes at least one "Municipal Solid Waste Landfill" Air Quality Standard Permit NSR authorization under 30 TAC § 116.621.	<input type="checkbox"/> YES <input checked="" type="checkbox"/> NO
◆	7. The application area includes at least one "Municipal Solid Waste Landfill Facilities and Transfer Stations" Standard Permit authorization under 30 TAC Chapter 330, Subchapter U.	<input type="checkbox"/> YES <input checked="" type="checkbox"/> NO
	8. The application area includes at least one "Concrete Batch Plant" Air Quality Standard Permit NSR authorization.	<input type="checkbox"/> YES <input checked="" type="checkbox"/> NO
◆	9. The application area includes at least one "Concrete Batch Plant with Enhanced Controls" Air Quality Standard Permit NSR authorization.	<input type="checkbox"/> YES <input checked="" type="checkbox"/> NO
◆	10. The application area includes at least one "Hot Mix Asphalt Plant" Air Quality Standard Permit NSR authorization.	<input type="checkbox"/> YES <input checked="" type="checkbox"/> NO

Texas Commission on Environmental Quality
Application Area-Wide Applicability Determinations and General Information
Form OP-REQ1
Federal Operating Permit Program

Date:	09/03/2024
Permit No.:	4119
RN No.:	RN109161745

For SOP applications, answer ALL questions unless otherwise directed.

◆ *For GOP applications, answer ONLY these questions unless otherwise directed.*

Form OP-REQ1: Page 86	
XII. New Source Review (NSR) Authorizations (continued)	
B. Air Quality Standard Permits (continued)	
◆ 11. The application area includes at least one “Rock Crusher” Air Quality Standard Permit NSR authorization.	<input type="checkbox"/> YES <input checked="" type="checkbox"/> NO
◆ 12. The application area includes at least one “Electric Generating Unit” Air Quality Standard Permit NSR authorization. <i>If the response to XII.B.12 is “NO,” go to Question XII.B.15.</i>	<input type="checkbox"/> YES <input checked="" type="checkbox"/> NO
◆ 13. For purposes of “Electric Generating Unit” Air Quality Standard Permit, the application area is located in the East Texas Region.	<input type="checkbox"/> YES <input type="checkbox"/> NO
◆ 14. For purposes of “Electric Generating Unit” Air Quality Standard Permit, the application area is located in the West Texas Region.	<input type="checkbox"/> YES <input type="checkbox"/> NO
◆ 15. The application area includes at least one “Boiler” Air Quality Standard Permit NSR authorization.	<input type="checkbox"/> YES <input checked="" type="checkbox"/> NO
◆ 16. The application area includes at least one “Sawmill” Air Quality Standard Permit NSR authorization.	<input type="checkbox"/> YES <input checked="" type="checkbox"/> NO
C. Flexible Permits	
1. The application area includes at least one Flexible Permit NSR authorization.	<input type="checkbox"/> YES <input checked="" type="checkbox"/> NO
D. Multiple Plant Permits	
1. The application area includes at least one Multi-Plant Permit NSR authorization.	<input type="checkbox"/> YES <input checked="" type="checkbox"/> NO

Texas Commission on Environmental Quality
Application Area-Wide Applicability Determinations and General Information
Form OP-REQ1
Federal Operating Permit Program

Date:	09/03/2024
Permit No.:	4119
RN No.:	RN109161745

For SOP applications, answer ALL questions unless otherwise directed.

◆ *For GOP applications, answer ONLY these questions unless otherwise directed.*

Form OP-REQ1: Page 87			
XII. NSR Authorizations (Attach additional sheets if necessary for sections E-J)			
E. PSD Permits and PSD Major Pollutants			
PSD Permit No.:	Issuance Date:	Pollutant(s):	
PSD Permit No.:	Issuance Date:	Pollutant(s):	
PSD Permit No.:	Issuance Date:	Pollutant(s):	
PSD Permit No.:	Issuance Date:	Pollutant(s):	
<i>If PSD Permits are held for the application area, please complete the Major NSR Summary Table located under the Technical Forms heading at: www.tceq.texas.gov/permitting/air/titlev/site/site_experts.html.</i>			
F. Nonattainment (NA) Permits and NA Major Pollutants			
NA Permit No.:	Issuance Date:	Pollutant(s):	
NA Permit No.:	Issuance Date:	Pollutant(s):	
NA Permit No.:	Issuance Date:	Pollutant(s):	
NA Permit No.:	Issuance Date:	Pollutant(s):	
<i>If NA Permits are held for the application area, please complete the Major NSR Summary Table located under the Technical Forms heading at: www.tceq.texas.gov/permitting/air/titlev/site/site_experts.html.</i>			
G. NSR Authorizations with FCAA § 112(g) Requirements			
NSR Permit No.:	Issuance Date:	NSR Permit No.:	Issuance Date:
NSR Permit No.:	Issuance Date:	NSR Permit No.:	Issuance Date:
NSR Permit No.:	Issuance Date:	NSR Permit No.:	Issuance Date:
NSR Permit No.:	Issuance Date:	NSR Permit No.:	Issuance Date:
◆ H. Title 30 TAC Chapter 116 Permits, Special Permits, Standard Permits, Other Authorizations (Other Than Permits By Rule, PSD Permits, NA Permits) for the Application Area			
Authorization No.: 140834	Issuance Date: 06/27/2016	Authorization No.:	Issuance Date:
Authorization No.:	Issuance Date:	Authorization No.:	Issuance Date:
Authorization No.:	Issuance Date:	Authorization No.:	Issuance Date:
Authorization No.:	Issuance Date:	Authorization No.:	Issuance Date:

Texas Commission on Environmental Quality
Application Area-Wide Applicability Determinations and General Information
Form OP-REQ1
Federal Operating Permit Program

Date:	09/03/2024
Permit No.:	4119
RN No.:	RN109161745

For SOP applications, answer ALL questions unless otherwise directed.

◆ *For GOP applications, answer ONLY these question unless otherwise directed.*

Form OP-REQ1: Page 88	
XII. NSR Authorizations (Attach additional sheets if necessary for sections E-J)	
◆ I. Permits by Rule (30 TAC Chapter 106) for the Application Area	
<i>A list of selected Permits by Rule (previously referred to as standard exemptions) that are required to be listed in the FOP application is available in the instructions.</i>	
PBR No.: 106.359	Version No./Date: Version 1 /Sept 10, 2013
PBR No.: 106.472	Version No./Date: Version 2/Sept 4, 2000
PBR No.: 106.473	Version No./Date: Version 2/Sept 4, 2000
PBR No.: 106.511	Version No./Date: Version 2/Sept 4, 2000
PBR No.:	Version No./Date:
PBR No.:	Version No./Date:
PBR No.:	Version No./Date:
PBR No.:	Version No./Date:
PBR No.:	Version No./Date:
PBR No.:	Version No./Date:
PBR No.:	Version No./Date:
PBR No.:	Version No./Date:
PBR No.:	Version No./Date:
PBR No.:	Version No./Date:
PBR No.:	Version No./Date:
PBR No.:	Version No./Date:
PBR No.:	Version No./Date:
◆ J. Municipal Solid Waste and Industrial Hazardous Waste Permits With an Air Addendum	
Permit No.:	Issuance Date:
Permit No.:	Issuance Date:
Permit No.:	Issuance Date:
Permit No.:	Issuance Date:

**FORM OP-REQ2
NEGATIVE APPLICABLE/SUPERSEDED REQUIREMENTS
DETERMINATION**

Form OP-REQ2
Negative Applicable/Superseded Requirement Determinations
Texas Commission on Environmental Quality

Date	Permit No.	Regulated Entity No.
9/03/2024	4119	RN109161745

Unit AI	Revision No.	Unit/Group/Process ID No.	Unit/Group/Process Applicable Form	Potentially Applicable Regulatory Name	Negative Applicability/Superseded Requirement Citation	Negative Applicability/Superseded Requirement Reason
		ECR-2212 ECR-2213 ECR-2214 ECR-2215	OP-REQ2	40 CFR 60 NSPS JJJJ	40 CFR 60.4230(a)	These units are electric compressor engines.
		E-VRUCOMP1 E-VRUCOMP2 E-VRUCOMP3 E-VRUCOMP4	OP-REQ2	40 CFR 60 NSPS JJJJ	40 CFR 60.4230(a)	These units are electric compressor engines
		HMO-4 HMO-5 HMO-781	OP-REQ2	40 CFR 60 NSPS Dc	40 CFR 60.40c(a)	These units are rated less than 10 MMBTUH

Form OP-REQ2
Negative Applicable/Superseded Requirement Determinations
Texas Commission on Environmental Quality

Date	Permit No.	Regulated Entity No.
9/03/2024	4119	RN109161745

Unit AI	Revision No.	Unit/Group/Process ID No.	Unit/Group/Process Applicable Form	Potentially Applicable Regulatory Name	Negative Applicability/Superseded Requirement Citation	Negative Applicability/Superseded Requirement Reason
		H-741 AMINE-HTR1 STB-HTR1 STB-HTR2 TEG-HT1 TEG-HT2 AMINE-HTR2 AMINE-HTR3 HTR-3	OP-REQ2	40 CFR 60 NSPS Dc	40 CFR 60.41(c)	These units are process heaters as defined in this subpart and excluded from the requirements in this subpart.
		TK-800 TK-801 TK-802 TK-803	OP-UA3	40 CFR 60 NSPS Kb	40 CFR 60.110b(d)(4)	These tanks are less than 10,000 bbl used to store condensate prior to custody transfer.
		TK-10730 TK-10731 TK-10732 TK-10733 TK-10734 TK-10735 TK-10736	OP-UA3	40 CFR 60 NSPS Kb	40 CFR 60.110b(d)(4)	These tanks are less than 10,000 bbl used to store condensate prior to custody transfer.

Form OP-REQ2
Negative Applicable/Superseded Requirement Determinations
Texas Commission on Environmental Quality

Date	Permit No.	Regulated Entity No.
9/03/2024	4119	RN109161745

Unit AI	Revision No.	Unit/Group/Process ID No.	Unit/Group/Process Applicable Form	Potentially Applicable Regulatory Name	Negative Applicability/Superseded Requirement Citation	Negative Applicability/Superseded Requirement Reason
		TK-10740 TK-10741 TK-10742 TK-10743 TK-10744 TK-10745 TK-10746	OP-UA3	40 CFR 60 NSPS Kb	40 CFR 60.110b(d)(4)	These tanks are less than 10,000 bbl used to store condensate prior to custody transfer.
		TK-804 TK-10719 TK-10720	OP-UA3	40 CFR 60 NSPS Kb	40 CFR 60.110b(d)(4)	These tanks are less than 10,000 bbl used to store produced water prior to custody transfer.
		TK-100 TK-2245 TK-10717 TK-10718 TK-20717 TK-20718 TK-20705	OP-UA3	40 CFR 60 NSPS Kb	40 CFR 60.110b(d)(4)	These tanks are less than 10,000 bbl used to store slop water prior to custody transfer.

Form OP-REQ2
Negative Applicable/Superseded Requirement Determinations
Texas Commission on Environmental Quality

Date	Permit No.	Regulated Entity No.
9/03/2024	4119	RN109161745

Unit AI	Revision No.	Unit/Group/Process ID No.	Unit/Group/Process Applicable Form	Potentially Applicable Regulatory Name	Negative Applicability/Superseded Requirement Citation	Negative Applicability/Superseded Requirement Reason
		BULLET TANKS	OP-REQ2	40 CFR 60 NSPS Kb	40 CFR 60.110b(d)(2)	This subpart does not apply to pressurized tanks designed to operated in excess of 204.9kPa and without emission to the atmosphere.
		LOAD-CONDENSATE	OP-REQ2	40 CFR 64	40 CFR 64.2(a)(3)	The source does not satisfy all the applicability criteria as the pre-control device emissions are less than required for a source to be major.

Form OP-REQ2

**Negative Applicable/Superseded Requirement Determinations
Texas Commission on Environmental Quality**

Date	Permit No.	Regulated Entity No.
9/03/2024	4119	RN109161745

Unit AI	Revision No.	Unit/Group/Process ID No.	Unit/Group/Process Applicable Form	Potentially Applicable Regulatory Name	Negative Applicability/Superseded Requirement Citation	Negative Applicability/Superseded Requirement Reason
		LOAD-CONDENSATE LOAD-PRODUCED WATER/SLOP LOAD2-PRODUCED WATER/SLOP	OP-REQ2	30 TAC Chapter 115, Loading and Unloading of VOC	115.212	This facility is not located in a covered attainment county or in a non-attainment county.
		LOAD2-CONDENSATE	OP-UA1	30 TAC Chapter 115, Loading and Unloading of VOC	115.212	This facility is not located in a covered attainment county or in a non-attainment county.
		AMINE-1	OP-UA10	40 CFR 64	40 CFR 64.2(a)(3)	The source does not satisfy all the applicability criteria as the pre-control device emissions are less than required for a source to be major.

Form OP-REQ2

Negative Applicable/Superseded Requirement Determinations
Texas Commission on Environmental Quality

Date	Permit No.	Regulated Entity No.
9/03/2024	4119	RN109161745

Unit AI	Revision No.	Unit/Group/Process ID No.	Unit/Group/Process Applicable Form	Potentially Applicable Regulatory Name	Negative Applicability/Superseded Requirement Citation	Negative Applicability/Superseded Requirement Reason
		TK-MET1 TK-MET2 TK-MET3 TK-MET4 TK-MET5 TK-MET6	OP-UA3	40 CFR 60 NSPS OOOOa	40 CFR 60.5430a(e)	These tanks are used to store VOC other than crude, condensate and/or produced water and thus are not considered storage vessels as defined under 40 CFR 60.5430a
		TK-MET1 TK-MET2 TK-MET3 TK-MET4 TK-MET5 TK-MET6	OP-UA3	40 CFR 60 NSPS Kb	40 CFR 60.110b(a)	These tanks have a design capacity of less than 75 cubic meters used to store VOC and are not affected sources.
		FL-1 FL-2 FL-3	OP-UA7	40 CFR 60 NSPS A	40 CFR 60.18(a)(1)	These flares are not affected sources as they do not control any NSPS affected sources present at the facility location.
		FL-1 FL-2 FL-3	OP-UA12	40 CFR 60 NSPS OOOOa	40 CFR 60.5365a(f)	These flares are not affected sources under this subpart as they do not control any NSPS affected sources present at the facility location.

Form OP-REQ2

TCEQ-10017 (Revised 05-15-02) OP-REQ2 Instructions
 This form for use by facilities subject to air quality permit

**Negative Applicable/Superseded Requirement Determinations
Texas Commission on Environmental Quality**

Date		Permit No.	Regulated Entity No.
9/03/2024	4119		RN109161745

Unit AI	Revision No.	Unit/Group/Process ID No.	Unit/Group/Process Applicable Form	Potentially Applicable Regulatory Name	Negative Applicability/Superseded Requirement Citation	Negative Applicability/Superseded Requirement Reason
		FL-1 FL-2 FL-3	OP-UA12	40 CFR 60 NSPS 0000b	40 CFR 60.5365b(f)	These flares are not affected sources as they do not control any affected sources under this subpart.
		TK-800 TK-801 TK-802 TK-803	OP-UA3	40 CFR 60 NSPS 0000b	40 CFR 60.5365b(e)	These tanks have not been modified or reconstructed after November 15, 2021, and therefore are not affected sources.
		TK-10730 TK-10731 TK-10732 TK-10733 TK-10734 TK-10735 TK-10736	OP-REQ2	40 CFR 60 NSPS 0000b	40 CFR 60.5365b(e)	These tanks have not been modified or reconstructed after November 15, 2021, and therefore are not affected sources.
		TK-804 TK-10719 TK-10720	OP-REQ2	40 CFR 60 NSPS 0000b	40 CFR 60.5365b(e)	These tanks have not been modified or reconstructed after November 15, 2021, and therefore are not affected sources.

Form OP-REQ2
Negative Applicable/Superseded Requirement Determinations
Texas Commission on Environmental Quality

Date	Permit No.	Regulated Entity No.
9/03/2024	4119	RN109161745

Unit AI	Revision No.	Unit/Group/Process ID No.	Unit/Group/Process Applicable Form	Potentially Applicable Regulatory Name	Negative Applicability/Superseded Requirement Citation	Negative Applicability/Superseded Requirement Reason
		TK-10740 TK-10741 TK-10742 TK-10743 TK-10744 TK-10745 TK-10746	OP-UA3	40 CFR 60 NSPS OOOOb	40 CFR 60.5365b(c)	These tanks have not been modified or reconstructed after November 15, 2021, and therefore are not affected sources.
		TK-100 TK-2245 TK-10717 TK-10718 TK-20717 TK-20718 TK-20705	OP-UA3	40 CFR 60 NSPS OOOOb	40 CFR 60.5365b(c)	These tanks have not been modified or reconstructed after November 15, 2021, and therefore are not affected sources.
		TK-MET1 TK-MET2 TK-MET3 TK-MET4 TK-MET5 TK-MET6	OP-UA3	40 CFR 60 NSPS OOOOb	40 CFR 60.5365b(c)	These tanks are used to store VOC other than crude, condensate and/or produced water and thus are not considered storage vessels as defined under 40 CFR 60.5430b

**Form OP-REQ2
Negative Applicable/Superseded Requirement Determinations
Texas Commission on Environmental Quality**

Date	Permit No.	Regulated Entity No.
9/03/2024	4119	RN109161745

Unit AI	Revision No.	Unit/Group/Process ID No.	Unit/Group/Process Applicable Form	Potentially Applicable Regulatory Name	Negative Applicability/Superseded Requirement Citation	Negative Applicability/Superseded Requirement Reason
		CR-2201 CR-2202 CR-2203 CR-2204 CR-2205 CR-2206 CR-2207 CR-2208 VCOMP-1 VCOMP-2	OP-UA2	40 CFR 60 NSPS 0000b	40 CFR 60.5365b(c)	These compressor sources have not been modified or reconstructed after November 15, 2021, and therefore are not affected sources.
		GRP-PROCESS CONTROLLERS	OP-UA12	40 CFR 60 NSPS 0000b	40 CFR 60.5365b(d)	The existing process controllers are not affected sources under this subpart and no new natural gas process controllers have been added to the site since November 15, 2021. Therefore, this is not an affected source under this subpart.

Form OP-REQ2
Negative Applicable/Superseded Requirement Determinations
Texas Commission on Environmental Quality

Date	Permit No.	Regulated Entity No.
9/03/2024	4119	RN109161745

Unit AI	Revision No.	Unit/Group/Process ID No.	Unit/Group/Process Applicable Form	Potentially Applicable Regulatory Name	Negative Applicability/Superseded Requirement Citation	Negative Applicability/Superseded Requirement Reason
		GRP-PNEUMATIC PUMPS	OP-UA12	40 CFR 60 NSPS OOOOb	40 CFR 60.5365b(h)	The existing pumps are not affected sources under this subpart and no new natural gas process pumps have been added to the site since November 15, 2021. Therefore, this is not an affected source under this subpart.
		AMINE-1 AMINE-2 AMINE-3	OP-UA10	40 CFR 60 NSPS OOOOb	40 CFR 60.5365b(g)	These amine units have a design capacity of less than 2LTD and have not been modified or reconstructed since November 15, 2021. Therefore, these amine units are not affected sources under this subpart.
		GRP-PROCESS-EQUIP	OP-UA12	40 CFR 60 NSPS OOOOb	40 CFR 60.5365b(f)(1)	There are no process unit equipment that were added or replaced after November 15, 2021. Therefore, this site is not an affected source.
		FUG-1	OP-UA12	40 CFR 60 NSPS OOOOb	40 CFR 60.5365b(f)(1)	This is not an affected source for fugitive due to the applicability date in this Subpart as no modification or reconstruction has occurred since November 15, 2021.

**FORM OP-REQ3
APPLICABLE REQUIREMENTS SUMMARY**

**Applicable Requirements Summary
Form OP-REQ3 (Page 3)
Federal Operating Permit Program**

Table 2a: Deletions

Date: 9/03/2024	Regulated Entity No.: RN109161745	Permit No.: 4119
Company Name: Brazos Midstream Operating LLC		
Area Name: Comanche Plant		

Revision No.	Unit/Group/Process ID No.	Unit/Group/Process Applicable Form	SOP/GOP Index No.	Pollutant	Applicable Regulatory Requirement Name	Applicable Regulatory Requirement Standard(s)
	CR-2209	OP-UA2	600000a-CR09	VOC	NSPS 0000a	§60.1 §60.5385a(a)(1) §60.5385a(a)(2) §60.5415a(c)(3)
	CR-2210	OP-UA2	600000a-CR10	VOC	NSPS 0000a	§60.1 §60.5385a(a)(1) §60.5385a(a)(2) §60.5415a(c)(3)
	CR-2211	OP-UA2	600000a-CR11	VOC	NSPS 0000a	§60.1 §60.5385a(a)(1) §60.5385a(a)(2) §60.5415a(c)(3)
	LOAD3-CONDENSATE	OP-MON	64CAM-LOADCON3	VOC	30 TAC 116	§64.2(a)

**Applicable Requirements Summary
Form OP-REQ3 (Page 4)
Federal Operating Permit Program**

Table 2b: Deletions

Date: 9/03/2024	Regulated Entity No.: RN109161745	Permit No.: 4119
Company Name: Brazos Midstream Operating LLC		
Area Name: Comanche Plant		

Revision No.	Unit/Group/Process ID No.	Unit/Group/Process Applicable Form	SOP/GOP Index No.	Pollutant	Monitoring and Testing Requirements	Recordkeeping Requirements	Reporting Requirements
	CR-2209	OP-UA2	600000a-CR09	VOC	§60.5410a(c)(1) §60.5415a(c)(1)	§60.5410a(c)(4)	§60.5410a(c)(3) §60.5415a(c)(2) §60.5420a(b)(4)
	CR-2210	OP-UA2	600000a-CR10	VOC	§60.5410a(c)(1)	§60.5410a(c)(4)	§60.5410a(c)(3) §60.5415a(c)(2) §60.5420a(b)(4)
	CR-2211	OP-UA2	600000a-CR11	VOC	§60.5415a(c)(1)	§60.5410a(c)(4)	§60.5410a(c)(3) §60.5415a(c)(2) §60.5420a(b)(4)
	LOAD3-CONDENSATE	OP-MON	64CAM-LOADCON3	VOC	CAM Summary/SP #140834	CAM Summary/SP #140834	CAM Summary/SP #140834

OP-UA FORMS

UNIT ATTRIBUTES FORMS

**Texas Commission on Environmental Quality
Miscellaneous Unit Attributes
Form OP-UA1 (Page 1)
Federal Operating Permit Program**

Date:	9/03/2024
Permit No.:	4119
Regulated Entity No.:	RN109161745

Unit ID No.	SOP/GOP Index No.	Unit Type	Date Constructed/Placed in Service	Functionally Identical Replacement	Maximum Rated Capacity	Technical Information and Unit Description
LOAD2-CONDENSATE	64CAM-LOADCON2	EP	8/01/2017			Plant 2 Condensate Loading point
TO-1A		CD	10/02/2019			Plant 1 Thermal Oxidizer
TO-2		CD	8/01/2017			Plant 2 Thermal Oxidizer
TO-3		CD	4/10/2018			Plant 3 Thermal Oxidizer

**Stationary Reciprocating Internal Combustion Engine Attributes
Form OP-UA2 (Page 4)**

Federal Operating Permit Program

Table 2a: Title 40 Code of Federal Regulations Part 63 (40 CFR Part 63)

**Subpart ZZZZ: National Emission Standards for Hazardous Air Pollutants for Stationary Reciprocating Internal Combustion Engines
Texas Commission on Environmental Quality**

Date	Permit No.	Regulated Entity No.
9/03/2024	4119	RN109161745

Unit ID No.	SOP/GOP Index No.	HAP Source	Brake HP	Construction/ Reconstruction Date	Nonindustrial Emergency Engine	Service Type	Stationary RICE Type
CR-2201	63ZZZZ-CR01	AREA	500+	06+			
CR-2202	63ZZZZ-CR02	AREA	500+	06+			
CR-2203	63ZZZZ-CR03	AREA	500+	06+			
CR-2204	63ZZZZ-CR04	AREA	500+	06+			
CR-2205	63ZZZZ-CR05	AREA	500+	06+			
CR-2206	63ZZZZ-CR06	AREA	500+	06+			
CR-2207	63ZZZZ-CR07	AREA	500+	06+			
CR-2208	63ZZZZ-CR08	AREA	500+	06+			

**Stationary Reciprocating Internal Combustion Engine Attributes
Form OP-UA2 (Page 4)**

Federal Operating Permit Program

Table 2a: Title 40 Code of Federal Regulations Part 63 (40 CFR Part 63)

**Subpart ZZZZ: National Emission Standards for Hazardous Air Pollutants for Stationary Reciprocating Internal Combustion Engines
Texas Commission on Environmental Quality**

Date	Permit No.	Regulated Entity No.
9/03/2024	4119	RN109161745

Unit ID No.	SOP/GOP Index No.	HAP Source	Brake HP	Construction/ Reconstruction Date	Nonindustrial Emergency Engine	Service Type	Stationary RICE Type
VCOMP-1	63ZZZZ-VRC1	AREA	500+	06+			
VCOMP-2	63ZZZZ-VRC2	AREA	250-300	06+			
GEN-1	63ZZZZ-GEN1	AREA	500+	06+			
GEN-2	63ZZZZ-GEN2	AREA	500+	06+			
GEN-3	63ZZZZ-GEN3	AREA	500+	06+			
GEN-4	63ZZZZ-GEN4	AREA	500+	06+			
GEN-5	63ZZZZ-GEN5	AREA	500+	06+			

**Stationary Reciprocating Internal Combustion Engine Attributes
Form OP-UA2 (Page 8)**

Federal Operating Permit Program

Table 4a: Title 40 Code of Federal Regulations Part 60 (40 CFR Part 60)

**Subpart JJJJ: Standards of Performance for Stationary Spark Ignition Internal Combustion Engines
Texas Commission on Environmental Quality**

Date	Permit No.	Regulated Entity No.
9/03/2024	4119	RN109161745

Unit ID No.	SOP/GOP Index No.	Construction/Reconstruction/Modification Date	Test Cell	Exemption	Temp Replacement	Horsepower	Fuel	AEL No.	Lean Burn	Commencing
CR-2201	60JJJJ-CR01	YES	NO	NONE	NO	1350+	NATGAS			CON
CR-2202	60JJJJ-CR02	YES	NO	NONE	NO	1350+	NATGAS			CON
CR-2203	60JJJJ-CR03	YES	NO	NONE	NO	1350+	NATGAS			CON
CR-2204	60JJJJ-CR04	YES	NO	NONE	NO	1350+	NATGAS			CON
CR-2205	60JJJJ-CR05	YES	NO	NONE	NO	1350+	NATGAS			CON
CR-2206	60JJJJ-CR06	YES	NO	NONE	NO	1350+	NATGAS			CON
CR-2207	60JJJJ-CR07	YES	NO	NONE	NO	1350+	NATGAS			CON
CR-2208	60JJJJ-CR08	YES	NO	NONE	NO	1350+	NATGAS			CON

**Stationary Reciprocating Internal Combustion Engine Attributes
Form OP-UA2 (Page 8)**

Federal Operating Permit Program

Table 4a: Title 40 Code of Federal Regulations Part 60 (40 CFR Part 60)

**Subpart JJJJ: Standards of Performance for Stationary Spark Ignition Internal Combustion Engines
Texas Commission on Environmental Quality**

Date	Permit No.	Regulated Entity No.
9/03/2024	4119	RN109161745

Unit ID No.	SOP/GOP Index No.	Construction/Reconstruction/Modification Date	Test Cell	Exemption	Temp Replacement	Horsepower	Fuel	AEL No.	Lean Burn	Commencing
VCOMP-1	63JJJJ-VRC1	YES	NO	NONE	NO	500-1350	NATGAS		NO	CON
VCOMP-2	63JJJJ-VRC2	YES	NO	NONE	NO	100-500	NATGAS			CON

**Stationary Reciprocating Internal Combustion Engine Attributes
Form OP-UA2 (Page 9)**

Federal Operating Permit Program

Table 4b: Title 40 Code of Federal Regulations Part 60 (40 CFR Part 60)

**Subpart JJJJ: Standards of Performance for Stationary Spark Ignition Internal Combustion Engines
Texas Commission on Environmental Quality**

Date	Permit No.	Regulated Entity No.
9/03/2024	4119	RN109161745

Unit ID No.	SOP/GOP Index No.	Manufacture Date	Displacement	Certified	Operation	Certified Modification	Service	Severe Duty	Optional Compliance
CR-2201	60JJJJ-CR01	N0710+		NO			NON		
CR-2202	60JJJJ-CR02	N0710+		NO			NON		
CR-2203	60JJJJ-CR03	N0710+		NO			NON		
CR-2204	60JJJJ-CR04	N0710+		NO			NON		
CR-2205	60JJJJ-CR05	N0710+		NO			NON		
CR-2206	60JJJJ-CR06	N0710+		NO			NON		
CR-2207	60JJJJ-CR07	N0710+		NO			NON		
CR-2208	60JJJJ-CR08	N0710+		NO			NON		
VCOMP-1	63JJJJ-VRC1	N0710+		NO			NON		
VCOMP-2	63JJJJ-VRC2	N0111+		NO			NON		

Stationary Reciprocating Internal Combustion Engine Attributes
Form OP-UA2 (Page 10)
Federal Operating Permit Program
Table 5a: Title 40 Code of Federal Regulations Part 60 (40 CFR Part 60)
Subpart IIII: Standards of Performance for Stationary Compression Ignition Internal Combustion Engines
Texas Commission on Environmental Quality

Date	Permit No.	Regulated Entity No.
9/03/2024	4119	RN109161745

Unit ID No.	SOP/GOP Index No.	Applicability Date	Exemptions	Service	Commencing	Manufacture Date
GEN-1	60IIII-GEN1	2005+	NONE	EMERG	CON	0406+
GEN-2	60IIII-GEN2	2005+	NONE	EMERG	CON	0406+
GEN-3	60IIII-GEN3	2005+	NONE	EMERG	CON	0406+
GEN-4	60IIII-GEN4	2005+	NONE	EMERG	CON	0406+
GEN-5	60IIII-GEN5	2005+	NONE	EMERG	CON	0406+

**Stationary Reciprocating Internal Combustion Engine Attributes
Form OP-UA2 (Page 11)**

**Table 5b: Title 40 Code of Federal Regulations Part 60 (40 CFR Part 60)
Federal Operating Permit Program
Subpart IIII: Standards of Performance for Stationary Compression Ignition Internal Combustion Engines
Texas Commission on Environmental Quality**

Date	Permit No.	Regulated Entity No.
9/03/2024	4119	RN109167145

Unit ID No.	SOP/GOP Index No.	Diesel	AES No.	Displacement	Generator Set	Model Year	Install Date
GEN-1	60IIII-GEN1	DIESEL		10-		2016	
GEN-2	60IIII-GEN2	DIESEL		10-		2016	
GEN-3	60IIII-GEN3	DIESEL		10-		2016	
GEN-4	60IIII-GEN4	DIESEL		10-		2016	
GEN-5	60IIII-GEN5	DIESEL		10-		2016	

**Stationary Reciprocating Internal Combustion Engine Attributes
Form OP-UA2 (Page 12)**

Federal Operating Permit Program

**Table 5c: Title 40 Code of Federal Regulations Part 60 (40 CFR Part 60)
Subpart IIII: Standards of Performance for Stationary Compression Ignition Internal Combustion Engines
Texas Commission on Environmental Quality**

Date	Permit No.	Regulated Entity No.
4/11/21024	4119	RN109161745

Unit ID No.	SOP/GOP Index No.	Kilowatts	Filter	AECD	Standard	Compliance Option	PM Compliance	Options
GEN-1	60IIII-GEN1	E560-2237			NO	MANU YES		
GEN-2	60IIII-GEN2	E560-2237			NO	MANU YES		
GEN-3	60IIII-GEN3	E560-2237			NO	MANU YES		
GEN-4	60IIII-GEN4	E560-2237			NO	MANU YES		
GEN-5	60IIII-GEN5	E560-2237			NO	MANU YES		

Storage Tank/Vessel Attributes
Form OP-UA3 (Page 3)
Federal Operating Permit Program
Table 3: Title 40 Code of Federal Regulations Part 60 (40 CFR Part 60)
Subpart Kb: Standards of Performance for Volatile Organic Liquid Storage Vessels
(Including Petroleum Liquid Storage Vessels)
Texas Commission on Environmental Quality

Date	Permit No.	Regulated Entity No.
9/03/2024	4119	RN109161745

Unit ID No.	SOP/GOP Index No.	Product Stored	Storage Capacity	WW Tank Control	Maximum TVP	Storage Vessel Description	AMEL ID No.	Guidepole	Reid Vapor Pressure	Control Device ID No.
TK-MET1	60Kb-MET1	VOL	10K-							
TK-MET2	60Kb-MET2	VOL	10K-							
TK-MET3	60Kb-MET3	VOL	10K-							
TK-MET4	60Kb-MET4	VOL	10K-							
TK-MET5	60Kb-MET5	VOL	10K-							
TK-MET6	60Kb-MET6	VOL	10K-							

**Storage Tank/Vessel Attributes
Form OP-UA3 (Page 64)**

Federal Operating Permit Program

Table 24a: Title 40 Code of Federal Regulations Part 60 (40 CFR Part 60)

Subpart OOOOa: Standards of Performance for Crude Oil and Natural Gas Facilities for which Construction, Modification or Reconstruction Commenced After September 18, 2015
Texas Commission on Environmental Quality

Date	Permit No.	Regulated Entity No.
9/03/2024	4119	RN109161745

Unit ID No.	SOP/GOP Index No.	Construction/Modification Date	Subject to Another Regulation	PTE	Compliance Option	Control Option	Control Device ID No.
TK-800	604Oa-P1CONTK	15+	NO	6-			
TK-801	604Oa-P1CONTK	15+	NO	6-			
TK-802	604Oa-P1CONTK	15+	NO	6-			
TK-803	604Oa-P1CONTK	15+	NO	6-			
TK-10730	604Oa-P2CONTK	15+	NO	6-			
TK-10731	604Oa-P2CONTK	15+	NO	6-			
TK-10732	604Oa-P2CONTK	15+	NO	6-			
TK-10733	604Oa-P2CONTK	15+	NO	6-			
TK-10734	604Oa-P2CONTK	15+	NO	6-			
TK-10735	604Oa-P2CONTK	15+	NO	6-			

Storage Tank/Vessel Attributes
Form OP-UA3 (Page 64)
Federal Operating Permit Program
Table 24a: Title 40 Code of Federal Regulations Part 60 (40 CFR Part 60)
Standards of Performance for Crude Oil and Natural Gas Facilities for which Construction, Modification or Reconstruction
Commenced After September 18, 2015
Texas Commission on Environmental Quality

Date	Permit No.	Regulated Entity No.
9/03/2024	4119	RN109161745

Unit ID No.	SOP/GOP Index No.	Construction/Modification Date	Subject to Another Regulation	PTE	Compliance Option	Control Option	Control Device ID No.
TK-10736	604Oa-P2CONTK	15+	NO	6-			
TK-10740	604Oa-P3CONTK	15+	NO	6-			
TK-10741	604Oa-P3CONTK	15+	NO	6-			
TK-10742	604Oa-P3CONTK	15+	NO	6-			
TK-10743	604Oa-P3CONTK	15+	NO	6-			
TK-10744	604Oa-P3CONTK	15+	NO	6-			
TK-10745	604Oa-P3CONTK	15+	NO	6-			
TK-10746	604Oa-P3CONTK	15+	NO	6-			
TK-804	604Oa-P1WTK	15+	NO	6-			
TK-10719	604Oa-P2WTK	15+	NO	6-			
TK-10720	604Oa-P3WTK	15+	NO	6-			

Storage Tank/Vessel Attributes
Form OP-UA3 (Page 64)
Federal Operating Permit Program
Table 24a: Title 40 Code of Federal Regulations Part 60 (40 CFR Part 60)
Subpart OOOOa: Standards of Performance for Crude Oil and Natural Gas Facilities for which Construction, Modification or Reconstruction
Commenced After September 18, 2015
Texas Commission on Environmental Quality

Date	Permit No.	Regulated Entity No.
9/03/2024	4119	RN109161745

Unit ID No.	SOP/GOP Index No.	Construction/Modification Date	Subject to Another Regulation	PTE	Compliance Option	Control Option	Control Device ID No.
TK-100	604Oa-P1STK	15+	NO	6-			
TK-2245	604Oa-P1STK	15+	NO	6-			
TK-10717	604Oa-P2STK	15+	NO	6-			
TK-10718	604Oa-P2STK	15+	NO	6-			
TK-20717	604Oa-P3STK	15+	NO	6-			
TK-20718	604Oa-P3STK	15+	NO	6-			
TK-20705	604Oa-P3STK	15+	NO	6-			

Texas Commission on Environmental Quality
 Flare Attributes
 Form OP-UA7 (Page 1)
 Federal Operating Permit Program
 Table 1: Title 30 Texas Administrative Code Chapter 111 (30 TAC Chapter 111)
 Control of Air Pollution from Visible Emissions and Particulate Matter

Date	Permit No.:	Regulated Entity No.
9/03/2024	4119	RN109161745

Unit ID No.	SOP/GOP Index No	Acid Gases Only	Emergency/Upset Conditions Only	Alternate Opacity Limitation (AOL)	AOL ID No.	Construction Date
ECF-1	30111-ECF1	NO	NO			
FL-1	30111-FL1	NO	YES			
FL-2	30111-FL2	NO	YES			
FL-3	30111-FL3	NO	YES			
FL-4	3-111-FL4	NO	NO			

**Texas Commission on Environmental Quality
Flare Attributes**

Form OP-UA7 (Page 3)

Federal Operating Permit Program

Table 3: Title 40 Code of Federal Regulations Part 60 and 61 (40 CFR Part 60 and 40 CFR Part 61)

Subpart A: General Provisions of Standards of Performance for New Stationary Sources and National Emission Standards for Hazardous Air Pollutants

Date	Permit No.:	Regulated Entity No.
9/03/2024	4119	RN109161745

Unit ID No.	SOP/GOP Index No.	Subject to 40 CFR §60.18	Adhering to Heat Content Specifications	Flare Assist Type	Flare Exit Velocity	Heating Value of Gas
ECF-1	60A-ECF1	NO				
FL-1	60A-FL1	NO				
FL-2	60A-FL2	NO				
FL-3	60A-FL3	NO				
FL-4	60-FL4	YES	YES	AIR		

Gas Sweetening/Sulfur Recovery Unit Attributes
Form OP-UA10 (Page 2)
Federal Operating Permit Program
Table 2a: Title 40 Code of Federal Regulations Part 60 (40 CFR Part 60)
Subpart LLL: Standards of Performance for Onshore Natural Gas Processing: SO₂ Emissions
Texas Commission on Environmental Quality

Date	Permit No.	Regulated Entity No.
9/03/2024	4119	RN109161745

Process ID No.	SOP/GOP Index No.	Onshore	Construction Date	Acid Gas Vented	Design Capacity
AMINE-1	60LLL-AU1	YES	11+	YES	2-
AMINE-2	60LLL-AU2	YES	11+	YES	2-
AMINE-3	60LLL-AU3	YES	11+	YES	2-

Fugitive Emission Unit Attributes
Form OP-UA12 (Page 170)
Federal Operating Permit Program
Table 19b: Title 40 Code of Federal Regulations Part 60 (40 CFR Part 60)
Standards of Performance for Crude Oil and Natural Gas Facilities for which Construction, Modification or Reconstruction
Commenced After September 18, 2015
Texas Commission on Environmental Quality

Date	Permit No.	Regulated Entity No.
9/03/2024	4119	RN109161745

Unit ID No.	SOP/GOP Index No.	Construction/Modification Date	Reciprocating Compressor	AMEL	Bypass Device
CR-2201 CR-2202 CR-2203 CR-2204	6040a-RCP1COMP	15+	RC26K-	NO	
CR-2205 CR-2206 CR-2207 CR-2208	6040a-RCP2COMP	15+	RC26K-	NO	
VCOMP-1 VCOMP-2	6040a-VRUCOMP	15+	RC26K-	NO	
ECR-2212 ECR-2213 ECR-2214 ECR-2215	6040a-ECOMP				
E-VRUCOM1 E-VRUCOM2 E-VRUCOM3 E-VRUCOM4	6040a-EVRU	15+	RC26K-	NO	

Fugitive Emission Unit Attributes
Form OP-UA12 (Page 177)
Federal Operating Permit Program
Table 19i: Title 40 Code of Federal Regulations Part 60 (40 CFR Part 60)
Subpart OOOOa: Standards of Performance for Crude Oil and Natural Gas Facilities for which Construction, Modification or Reconstruction
Commenced After September 18, 2015
Texas Commission on Environmental Quality

Date	Permit No.	Regulated Entity No.
9/03/2024	4119	RN109161745

Unit ID. No.	SOP/GOP Index No.	Title 40CFR Part 60, Subpart OOOOa Fugitives				Unit Components (continued)		
		Gas/Vapor or Light Liquid Service	Design Capacity < 10MM	2.0%	Valves	AMEL	AMEL ID No.	Complying with 60.482-7a
FUG-1	6040a-GVVALVES	YES	NO	YES	NO			YES

Fugitive Emission Unit Attributes
Form OP-UA12 (Page 179)
Federal Operating Permit Program
Table 19k: Title 40 Code of Federal Regulations Part 60 (40 CFR Part 60)
Subpart 0000a: Standards of Performance for Crude Oil and Natural Gas Facilities for which Construction, Modification or Reconstruction
Commenced After September 18, 2015
Texas Commission on Environmental Quality

Date	Permit No.	Regulated Entity No.
9/03/2024	4119	RN109161745

Unit ID. No.	SOP/GOP Index No.	Title 40 CFR				Components (continued)			Complying with 60.482-8a
		Part 60,		Subpart 0000a		Fugitive Unit	Connectors		
		Heavy or Light Liquid Service	Pressure	Relief Devices	Heavy Liquid Service		AMEL	AMEL ID No.	
FUG-1	6040a-HLLPRD	YES	NO	NO	YES				
FUG-1	6040a-HLLCONN				YES	NO			YES

Fugitive Emission Unit Attributes
Form OP-UA12 (Page 180)
Federal Operating Permit Program
Table 19: Title 40 Code of Federal Regulations Part 60 (40 CFR Part 60)
Subpart OOOOa: Standards of Performance for Crude Oil and Natural Gas Facilities for which Construction, Modification or Reconstruction
Commenced After September 18, 2015
Texas Commission on Environmental Quality

Date	Permit No.	Regulated Entity No.
9/03/2024	4119	RN109161745

Unit ID. No.	SOP/GOP Index No.	Title 40 CFR Part 60, Subpart OOOOa			Fugitive Unit	Components	Control Device ID No.
		Closed-Vent Systems	AMEL	AMEL ID No.			

Fugitive Emission Unit Attributes
Form OP-UA12 (Page 182)
Federal Operating Permit Program
Table 19n: Title 40 Code of Federal Regulations Part 60 (40 CFR Part 60)
Subpart OOOOa: Standards of Performance for Crude Oil and Natural Gas Facilities for which Construction, Modification or Reconstruction
Commenced After September 18, 2015
Texas Commission on Environmental Quality

Date	Permit No.	Regulated Entity No.
9/03/2024	4119	RN109161745

Unit ID. No.	SOP/GOP Index No.	Title 40 CFR Part 60, Subpart OOOOa			Fugitive Unit Components (continued)	
		Flare	AMEL	AMEL ID No.	Complying with 60.482-10a	Control Device ID No.
FUG-1	6040a-FL4	YES	NO	NO	YES	FL-4

Fugitive Emission Unit Attributes
Form OP-UA12 (Page 184)
Federal Operating Permit Program
Table 19p: Title 40 Code of Federal Regulations Part 60 (40 CFR Part 60)
Subpart OOOOa: Standards of Performance for Crude Oil and Natural Gas Facilities for which Construction, Modification or Reconstruction
Commenced After September 18, 2015
Texas Commission on Environmental Quality

Date	Permit No.	Regulated Entity No.
9/03/2024	4119	RN109161745

Unit ID. No.	SOP/GOP Index No.	Title 40 CFR Part 60, Subpart OOOOa Fugitive Unit Components (continued)
CR-2201; CR-2202; CR-2203; CR-2204	6040a-RCP1COMP	Title 40 CFR Part 60, Subpart OOOOa Fugitive Unit Description Reciprocating compressors units at Plant 1
CR-2205; CR-2206; CR-2207; CR-2208	6040a-RCP2COMP	Reciprocating compressors units at Plant 2
VCOMP-1; VCOMP-2	6040a-VRUCOMP	Reciprocating compressors units less than 1000 hp
ECR-2212; ECR-2213; ECR-2214; ECF2215	6040a-ECOMP	Electric compressor units
E-VRUCOM1; E-VRUCOM2; E-VRUCOM3; E-VRUCOM4	6040a-EVRUCOMP	Electric compressor units
FUG-1	6040a-PNEUCONTR	Sitewide pneumatic controllers at a Plant 1, 2 and 3
FUG-1	6040a-PNEUPUMP	Sitewide pneumatic pumps at Plant 1, 2 and 3
FUG-1	6040a-PUMPLL	Sitewide Pumps in light liquid service at Plant 1, 2 and 3
FUG-1	6040a-PRD	Sitewide Pressure relief devices at Plant 1, 2 and 3
FUG-1	6040a-VALVEOEL	Sitewide Open ended line valves at Plant 1, 2 and 3

Fugitive Emission Unit Attributes
Form OP-UA12 (Page 184)
Federal Operating Permit Program
Table 19p: Title 40 Code of Federal Regulations Part 60 (40 CFR Part 60)
Subpart OOOOa: Standards of Performance for Crude Oil and Natural Gas Facilities for which Construction, Modification or Reconstruction
Commenced After September 18, 2015
Texas Commission on Environmental Quality

Date	Permit No.	Regulated Entity No.
9/03/2024	4119	RN109161745

Unit ID. No.	SOP/GOP Index No.	Title 40 CFR Part 60, Subpart OOOOa Fugitive Unit Components (continued)
FUG-1	6040a-GVVALVES	Title 40 CFR Part 60, Subpart OOOOa Fugitive Unit Components (continued)
FUG-1	6040a-HLLPRD	Title 40 CFR Part 60, Subpart OOOOa Fugitive Unit Description
FUG-1	6040a-HLLCONN	Sitewide valves in gas and vapor service at Plant 1, 2 and 3
FUG-1	6040a-ECF1	Sitewide Pressure Relief Devices in Heavy Liquid or Light Liquid Service
FUG-1	6040a-FL4	Connectors in Heavy Liquid or Light Liquid Service
FUG-1	6040a-GVCONN	Enclosed combustor for storage tank control at Plant 1
		Flare for storage tank control at Plant 2 and 3
		Sitewide connectors in gas/vapor service at Plant 1, 2 and 3.

**FORM OP-SUMR
INDIVIDUAL UNIT SUMMARY REVISIONS**

**Texas Commission on Environmental Quality
Federal Operating Permit Program
Individual Unit Summary for Revisions
Form OP-SUMR
[Table 1](#)**

Date	Permit No.	Regulated Entity No.
9/03/2024	4119	RN109161745

Unit/Process AI	Unit/Process Revision No.	Unit/Process ID No.	Unit/Process Applicable Form	Unit/Process Name/ Description	Unit/Process CAM	Preconstruction Authorizations 30 TAC Chapter 116/ 30 TAC Chapter 106	Preconstruction Authorizations Title I
D	1	CR-2209	OP-UA2	Residue Compressor -9		140834	
D	2	CR-2210	OP-UA2	Residue Compressor-10		140834	
D	3	CR-2211	OP-UA21	Residue Compressor 11		140834	
D	4	LOAD3-CONDENSATE	OP-UA1	Condensate Loading III	Y	140834	

**FORM OP-MON
MONITORING REQUIREMENTS**

**Texas Commission on Environmental Quality
Monitoring Requirements
Form OP-MON (Page 5)
Federal Operating Permit Program**

Table 2a: CAM/PM Deletions

I. Identifying Information
Account No.: RFA032E
RN No.:RN109161745
CN:CN605077106
Permit No.: 4119
Project No.:
Area Name: Comanche Plant
Company Name: Brazos Midstream Operating LLC
II. Unit/Emission Point/Group/Process Information
Revision No.:4
Unit/EPN/Group/Process ID No.: LOAD3-CONDENSATE
Applicable Form:OP-UA1
III. Applicable Regulatory Requirement
Name: 30 TAC Chapter 116
SOP/GOP Index No.: 64CAM-LOADCON3
Pollutant: VOC
Main Standard: NSR-140834
IV. Title V Monitoring Information
Monitoring Type: CAM
CAM/PM Option No.: CAMG-OG-FL-001
V. Control Device Information
Control Device ID No.: FL-4
Control Device Type: Flare
VI. Type of Deletion
Monitoring Requirement: DELETE
Control Device: DELETE

**Texas Commission on Environmental Quality
Monitoring Requirements
Form OP-MON (Page 6)**

Table 2b: CAM/PM Control Device Deletions

Emission Unit ID No.	Control Device ID No.	Control Device Type
LOAD3-CONDENSATE	FL-4	Flare

SECTION 3.0

FIGURES

**FIGURE 2
PROCESS FLOW DIAGRAM**

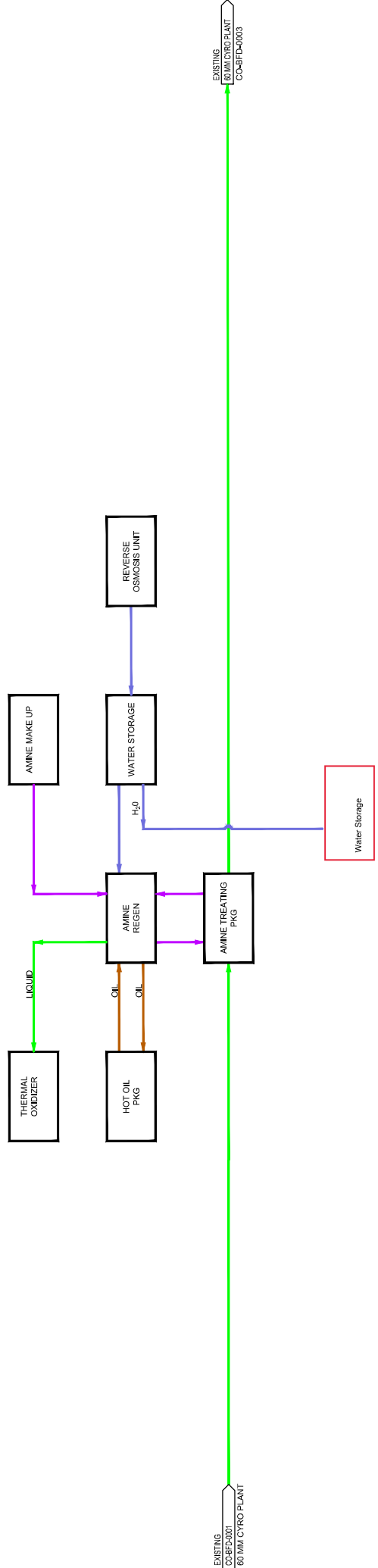

COMANCHE PLANT 1 GAS TREATMENT PROCESS

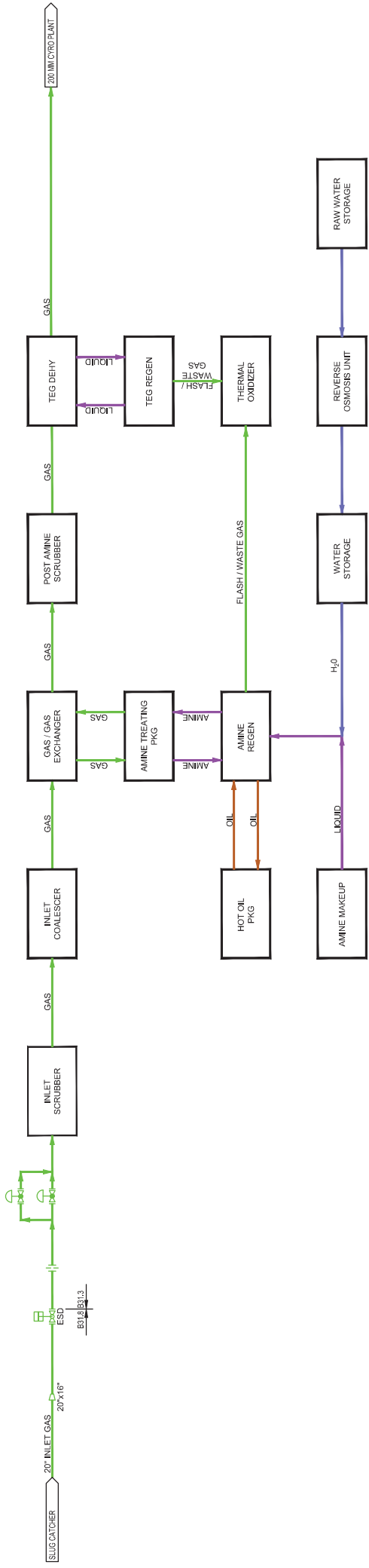

COMANCHE PLANT II and III Gas Treatment Process

BRAZOS COMANCHE BLOCK FLOW DIAGRAM

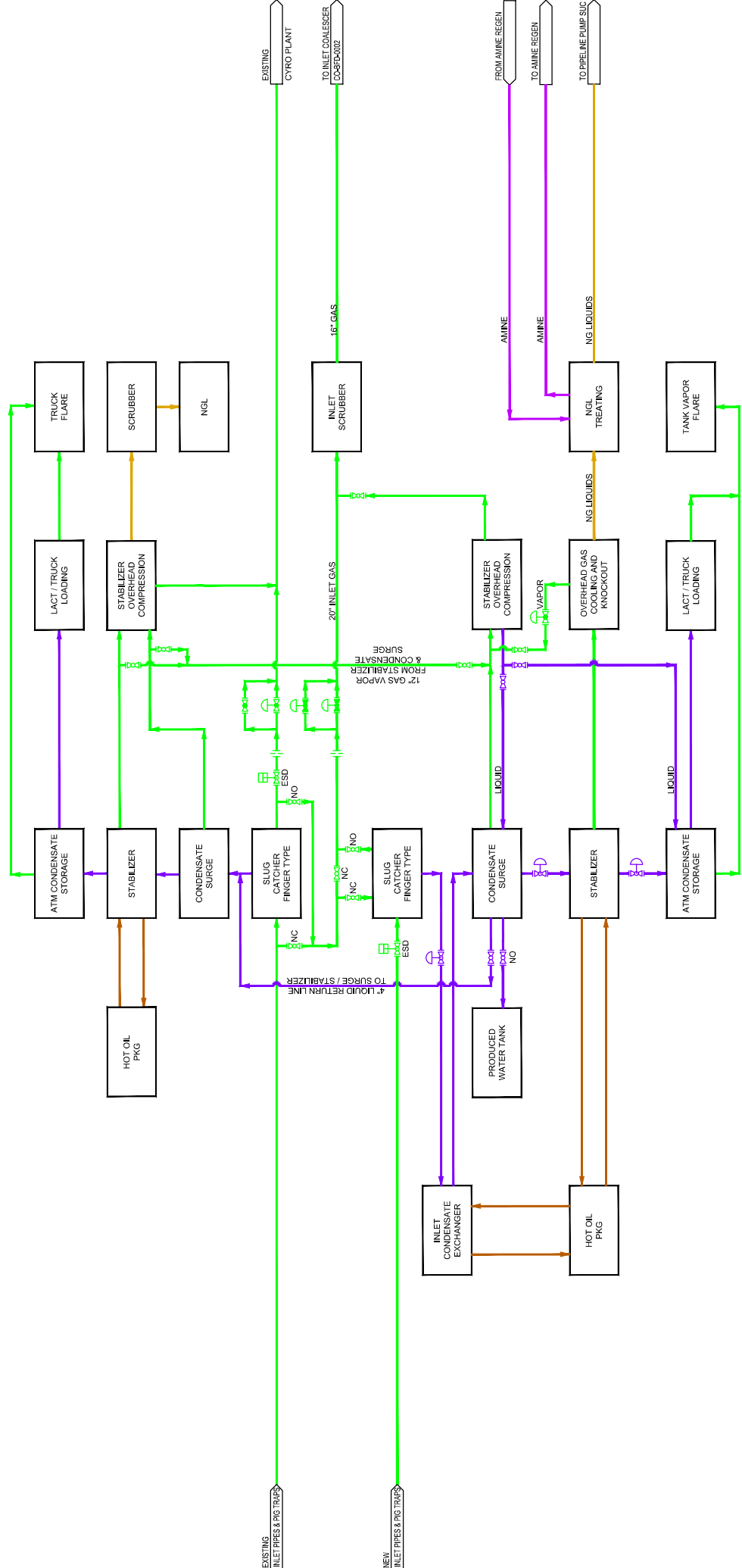

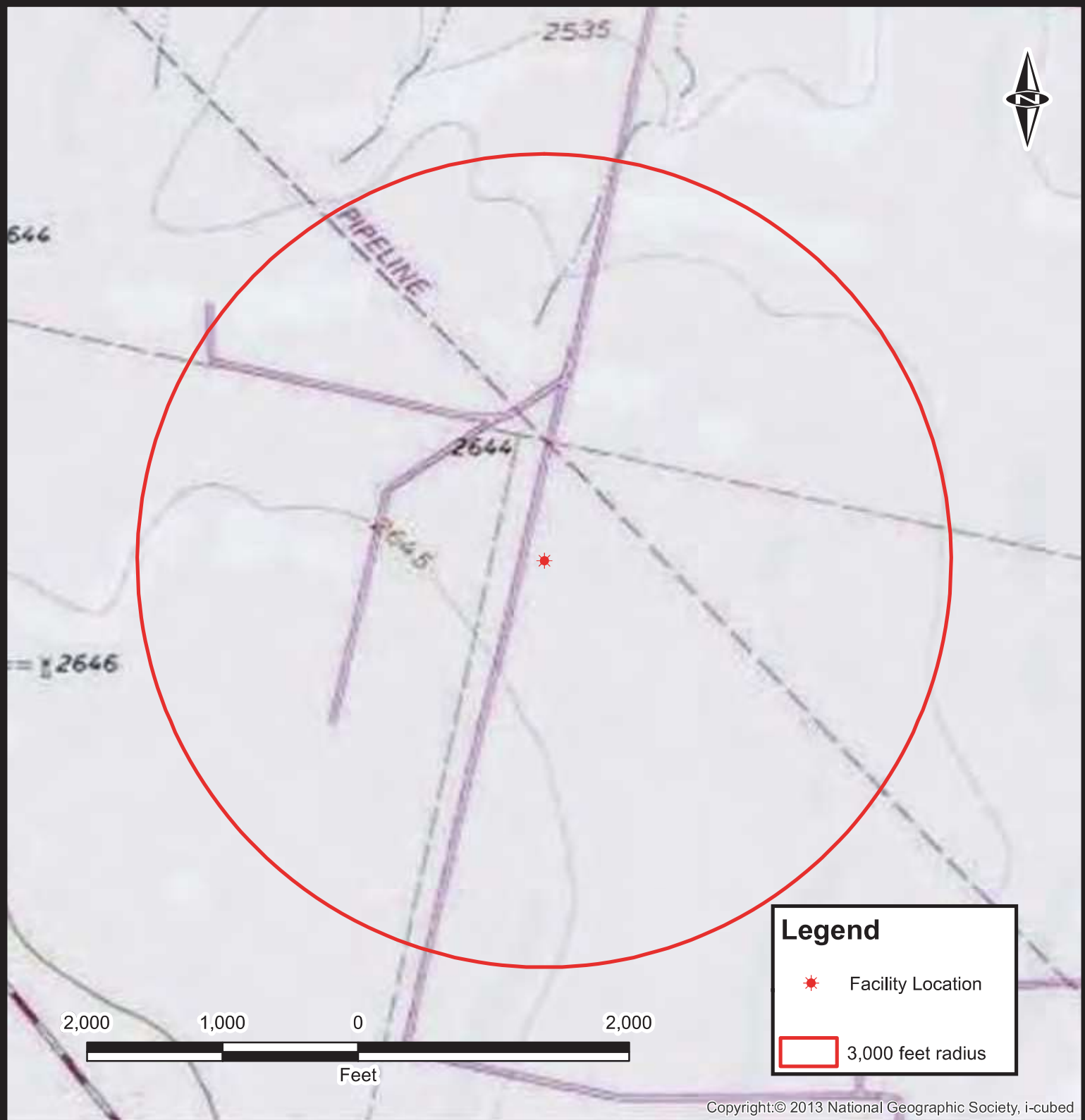

COMANCHE PLANT I, II and III Stabilization Process

**FIGURE 3
SITE LOCATION MAP**



Legend

-  Facility Location
-  3,000 feet radius

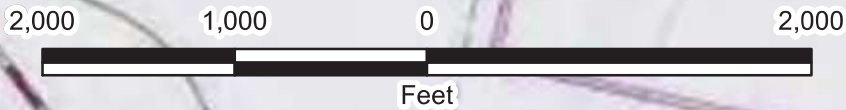

Copyright:© 2013 National Geographic Society, i-cubed



Sources: Esri, HERE, DeLorme, USGS, Intermap, increment P Corp., NRCAN, Esri Japan, METI, Esri China (Hong Kong), Swire, (Thailand), MapmyIndia, © OpenStreetMap

BRAZOS MIDSTREAM
 FT. WORTH, TEXAS
 COMANCHE PLANT

SITE LOCATION MAP

REEVES COUNTY, TEXAS



Drawn:	ADB
Checked:	ARA
Approved:	GRM
Date:	5/20/2016
Project No.:	13574

FIGURE 1