

Kimberly Cunningham

From: Kimberly Cunningham
Sent: Wednesday, May 13, 2026 9:32 AM
To: OCC-NSR; R6AirPermitsTX@epa.gov; Robert Webb; ai@cfl.rr.com
Cc: RFCAIR3; Rory Ashurst
Subject: INITIAL, Wilbarger Humane Society, Project: 409279, Permit(s): 184013,
Attachments: Wilbarger Public Notice.docx; NORI Spanish.docx

Please see Public Notice attached.

Kimberly Cunningham

From: Robert Webb <fluidpusher8246@att.net>
Sent: Wednesday, May 13, 2026 8:35 AM
To: Kimberly Cunningham
Cc: ai@cfl.rr.com; 'Wilbarger Humane Society'; 'Nathan Blackstock | US Cremation Equipment'
Subject: Re: Answer Language for Public Notice Wilbarger Humane Society DRAFT 184013_409279

Sounds good. Thanks for the help. Robert

[Sent from AT&T Yahoo Mail for iPhone](#)

On Wednesday, May 13, 2026, 8:33 AM, Kimberly Cunningham <Kimberly.Cunningham@tceq.texas.gov> wrote:

Mr. Webb,

I asked the supervisor for the technical team that will receive your project your question. He said there can be no changes in the language of the public notice.

When I asked different technical team supervisor a similar question, she explained that the agency needs the language in public notices to be consistent across the board.

As for your second question – Once I complete the final public notice package, you will receive it via email. The document containing the English NORI has directions on what and how to publish.

I hope this answers your questions,

Kimberly

From: Kimberly Cunningham
Sent: Wednesday, May 13, 2026 8:03 AM
To: 'Robert Webb' <fluidpusher8246@att.net>; ai@cfl.rr.com
Cc: 'Wilbarger Humane Society' <whs76384@gmail.com>; 'Nathan Blackstock | US Cremation

Equipment' <nblackstock@uscremationequipment.com>

Subject: Language for Public Notice Wilbarger Humane Society DRAFT 184013_409279

Hi Mr. Webb,

I'm not sure animal carcass incinerator in the title and description can be changed.

I will check on that and get back to you.

Kimberly

From: Robert Webb <fluidpusher8246@att.net>

Sent: Tuesday, May 12, 2026 6:04 PM

To: ai@cfl.rr.com; Kimberly Cunningham <Kimberly.Cunningham@tceq.texas.gov>

Cc: FLUIDPUSHER8246@ATT.NET; 'Wilbarger Humane Society' <whs76384@gmail.com>;

'Nathan Blackstock | US Cremation Equipment' <nblackstock@uscremationequipment.com>

Subject: Re: Completed Spanish Notice Wilbarger Humane Society DRAFT 184013_409279

It all looks good to me. Is there any way to change the wording that says animal carcass incinerator. Sounds a little cruel. Also do I post this in the newspaper or what happens now. Thanks Robert

[Sent from AT&T Yahoo Mail for iPhone](#)

On Tuesday, May 12, 2026, 11:03 AM, ai@cfl.rr.com wrote:

Dear Kimberly & Robert:

Attached are the completed NORI (Spanish) version and the English draft public notice. **Robert, you need to approve the public notice so we can proceed.**

Respectfully,
AI ENVIRONMENTAL CONSULTING SERVICES, INC.

Luis Llorens

From: Kimberly Cunningham <Kimberly.Cunningham@tceq.texas.gov>
Sent: Tuesday, May 12, 2026 11:06 AM
To: AI@CFL.RR.COM
Cc: FLUIDPUSHER8246@ATT.NET
Subject: Wilbarger Public Notice DRAFT 184013_409279

Mr. Llorens,

Please send approval within **2 business days**.

The NORI is a legally approved document and only the items listed below are subject to approval/correction. Please review carefully and provide corrections including a revised application as needed:

- Street address or driving directions to the facility
- Hyperlink for the map to facility - please confirm the map shows the general vicinity location of the facility
- Contaminant's list
- Public viewing place (must be in the same county as the facility and may be required to have internet access)
- For renewal applications, check all previous permitting actions since initial issuance or last renewal to make sure they are listed in Example A
 - Incorporation / consolidation of registrations for PBRs and Standard Permits being included with this application
 - Emission factor changes
 - Qualified facility changes
- Public Notice Technical Contact information
- Big or small business status (Small businesses will not receive Example B)

For the Spanish template, all italic notes should be replaced with the corresponding Spanish translations based on the English template.

Please do not publish until you receive an email containing an administratively complete letter and public notice package. Your prompt assistance is appreciated.

Kimberly Cunningham
License & Permit Specialist
Air Permits Division, TCEQ
512-239-1114
Kimberly.Cunningham@tceq.texas.gov



Brooke T. Paup, *Chairwoman*
Catarina R. Gonzales, *Commissioner*
Tonya R. Miller, *Commissioner*
Kelly Keel, *Executive Director*



TEXAS COMMISSION ON ENVIRONMENTAL QUALITY

Protecting Texas by Reducing and Preventing Pollution

May 13, 2026

MR ROBERT WEBB
OWNER
WILBARGER HUMANE SOCIETY
2805 SULLIVAN ST
VERNON TX 76384-3316

Re: Declaration of Administrative Completeness
Animal Carcass Incinerator Registration for an Air Quality Standard Permit
Air Quality Registration Number: 184013
Animal Carcass Incinerator
Vernon, Wilbarger County
Customer Reference Number: CN606511434
Regulated Entity Number: RN112446729

Dear Mr. Webb:

The Texas Commission on Environmental Quality (TCEQ) has declared the above-referenced application, received on May 11, 2026, administratively complete on May 13, 2026.

You are now required to publish notice of your proposed activity no later than the 30th day after the executive director received the application, which is June 10, 2026. To help you meet the regulatory requirements associated with this notice, we have included the following items:

- Notice for Newspaper Publication
- Instructions for Public Notice
- Affidavits of Publication
- Notification List

Please note that it is very important that you follow all directions in the enclosed instructions. If you do not, you may be required to republish the notice. Some common errors are the unauthorized changing of notice wording or font, omission of air contaminants, and inaccurate plant site location information represented in the application. Additional information can be found at www.tceq.texas.gov/permitting/air/bilingual/how1_2_pn.html or **if you have any questions, please contact us before you proceed with publication.**

The following items and time limitations are also described in the enclosed instructions. However, due to their importance we want to highlight them for you. **The processing of your application may be delayed if these time limitations are not met.**

1. Publish the enclosed notice no later than the 30th day after the date the executive director received the application, which is June 10, 2026 (see this letter's first paragraph for the application received date).
2. You may also be required to publish notice in an alternate language (refer to the enclosed *Instructions for Public Notice*). The Spanish notice templates are available at:

Mr. Robert Webb
Page 2
May 13, 2026

Re: Registration: 184013

www.tceq.texas.gov/permitting/air/nav/air_publicnotice.html

3. Ensure a copy of your application is provided to the TCEQ Regional Office that has oversight for the county in which you intend to operate your plant. This copy must be in place at the TCEQ Regional Office for the entire public comment period and be accessible to the public for review and copying.
4. Mail or email proof of publication of the notices, which show publication date and newspaper name, to the TCEQ Office of the Chief Clerk and mail copies to those on the enclosed *Notification List* within **10 business days** after the notice is published.
5. Return the *Affidavit of Publication for Air Permitting* (enclosed) and, if applicable, *Alternative Language Affidavit of Publication for Air Permitting* (enclosed) and the **Public Notice Verification (Form TCEQ-20546)** to the Office of the Chief Clerk and copies to those on the enclosed *Notification List* within **10 business days** after the notice is published in the newspaper. **The public notice verification form is available at www.tceq.texas.gov/permitting/air/nav/air_publicnotice.html.**

If you do not comply with **all** requirements described in the instructions, the TCEQ cannot continue processing the application and may take other actions.

If you have any questions regarding publication requirements, please contact the Office of the Chief Clerk at (512) 239-3300. If you have any other questions, please contact Ms. Kimberly Cunningham at (512) 239-1114.

Sincerely,



Nancy Birdsong, Team Leader
Air Permits Initial Review Team
Air Permits Division
Texas Commission on Environmental Quality

Enclosure

cc: Air Section Manager, Region 3 - Abilene

Project Number: 409279

TEXAS COMMISSION ON ENVIRONMENTAL QUALITY



NOTICE OF APPLICATION FOR AN AIR QUALITY STANDARD PERMIT FOR AN ANIMAL CARCASS INCINERATOR

PROPOSED AIR QUALITY REGISTRATION NUMBER 184013

APPLICATION. Wilbarger Humane Society, 2805 Sullivan Street, Vernon, Texas 76384-3316 has applied to the Texas Commission on Environmental Quality (TCEQ) for an Air Quality Standard Permit, Registration Number 184013, which would authorize construction of an animal carcass incinerator. The facility is proposed to be located at 2805 Sullivan Street, Vernon, Wilbarger County, Texas 76384. This link to an electronic map of the site or facility's general location is provided as a public courtesy and not part of the application or notice. For exact location, refer to application. <https://gisweb.tceq.texas.gov/LocationMapper/?marker=-99.298388,34.162977&level=13>. This application was submitted to the TCEQ on May 11, 2026. The primary function of this facility is to properly dispose of animal carcasses through incineration. The executive director has determined the application was administratively complete on May 13, 2026.

PUBLIC COMMENT. Public written comments about this application may be submitted at any time during the public comment period. The public comment period begins on the first date notice is published and extends to 30 days from the publication date. Public comments may be submitted either in writing to Texas Commission on Environmental Quality, Office of the Chief Clerk, MC-105, P.O. Box 13087, Austin, Texas 78711-3087, or electronically at www14.tceq.texas.gov/epic/eComment/. Please be aware that any contact information you provide, including your name, phone number, email address and physical address will become part of the agency's public record.

RESPONSE TO COMMENTS. A written response to all relevant comments will be prepared by the executive director after the comment period closes. The response, along with the executive director's decision on the application, will be mailed to everyone who submitted public comments and requested to be added to the mailing list. The response to comments will be posted in the permit file for viewing.

The executive director shall approve or deny the application not later than 30 days after the end of the public comment period, considering all comments received within the comment period, and base this decision on whether the application meets the requirements of the standard permit.

CENTRAL/REGIONAL OFFICE. The application will be available for viewing and copying at the TCEQ Central Office and the TCEQ Abilene Regional Office, located at 1977 Industrial Boulevard, Abilene, Texas 79602-7833, during the hours of 8:00 a.m. to 5:00 p.m., Monday through Friday, beginning the first day of publication of this notice. The application, including any updates, is available electronically at the following webpage: <https://www.tceq.texas.gov/permitting/air/airpermit-applications-notices>.

INFORMATION. For more information about the permitting process, please call the TCEQ Public Education Program, Toll Free, at 1-800-687-4040 or visit their website at www.tceq.texas.gov/goto/pep. Si desea información en Español, puede llamar al 1-800-687-4040. You can also view our website for public participation opportunities at www.tceq.texas.gov/goto/participation.

Further information may also be obtained from Wilbarger Humane Society, 2805 Sullivan Street, Vernon, Texas 76384-3316, or by calling Mr. Luis Llorens, President Project Manager, AI Environmental Consulting Services, Inc. at (407) 923-9345.

Notice Issuance Date: May 13, 2026

TEXAS COMMISSION ON ENVIRONMENTAL QUALITY



Instructions for Public Notice For Air Quality Standard Permit for Animal Carcass Incinerators

Notice of Application

Your application has been declared administratively complete and now you must comply with the following instructions:

Please Review Notice

We have included in the notice all of the information which we believe is necessary. Please read it carefully and notify us immediately if it contains any errors or omissions. You are responsible for ensuring the accuracy of all information published. You may not change the text of the notice without prior approval from the TCEQ.

Newspaper Notice

- You must publish the enclosed Notice of Application no later than the 30th day after the date the executive director received the application, which is June 10, 2026 (see this letter's first paragraph for the application received date).
- You must publish the enclosed Notice of Application at your expense, in a newspaper of general circulation in the municipality in which the facility is proposed to be located or in the municipality nearest to the proposed location of the facility.
- You must publish this notice in one issue of any applicable newspaper.
- You will find an example notice enclosed in this package. This example must be published in the "public notice" section of the newspaper.

Alternate Language Notice

In certain circumstances, applicants for air permits must complete notice in alternate languages.

- Public notice rules require the applicant to determine whether a bilingual program is required at either the elementary or middle school nearest to the proposed facility location. Bilingual education programs are determined on a district-wide basis. When students who are required to attend either school are eligible to be enrolled in a bilingual education program, some alternative language notice is required (newspaper notice).
- Since the school district, and not the schools, must provide the bilingual education program, these programs do not have to be located at the above-mentioned schools to trigger the alternative language notice requirement. If there are students who would normally attend the nearest schools, but are eligible to be taught in a bilingual education program at a different location, alternative language notice is required.
- If triggered, publication of alternative language notices must be made in a newspaper or publication printed primarily in each language taught in the bilingual education program. This

notice is required if such a newspaper or publication exists in the municipality or the county where the facility is or will be located.

- The applicant must demonstrate a good faith effort to identify a newspaper or publication in the required language. If a general circulation newspaper or publication printed in such language cannot be found, publishing in that language is not required. Publication in an alternative language section or insertion within a large publication which is not printed primarily in that alternative language does not satisfy these requirements.
- It is suggested the applicant work with the local school district for the following:
 - (a) Determine if a bilingual program is required in the district;
 - (b) Determine which language is required by the bilingual program;
 - (c) Locate the nearest elementary and middle schools; and
 - (d) Determine if any students attending either school are eligible to be enrolled in a bilingual educational program.

Proof of Publication

- You must submit proof of publication that shows the notice, the date of publication, and the name of the newspaper to the Office of the Chief Clerk within **10 business days** after the date of publication. Acceptable proofs of publication are 1) copies of the published notice or 2) the newspaper clippings of the published notice. If you choose to submit copies of the published notice to the Office of the Chief Clerk, copies must be on standard-size 8½" x 11" paper and must show the actual size of the published notice (do not reduce the image when making copies). Published notices longer than 11" must be copied onto multiple 8½" x 11" pages. Please note, submitting a copy of your published notice could result in faster processing of your application. It is recommended that you maintain newspaper clippings or tear sheets of the notice for your records.
- You must submit the **affidavits of publication** and the **Public Notice Verification Form (Form TCEQ-20546)** with the proof of publication described above to the Office of the Chief Clerk. **You must use the enclosed affidavit.** The affidavit must clearly identify the applicant's name and TCEQ Registration Number. **The public notice verification form is available at http://www.tceq.texas.gov/permitting/air/nav/air_publicnotice.html.**
- The **affidavits of publication and acceptable proof of publication of the published notices** should be emailed to PROOFS@tceq.texas.gov or mailed to:

Texas Commission on Environmental Quality
Office of the Chief Clerk, MC-105
Attn: Notice Team
P.O. Box 13087
Austin, Texas 78711-3087

Please ensure that the affidavits you send to the Chief Clerk have all blanks filled in correctly.

- **Photocopies of newspaper clippings, affidavits, and verification form must also** be sent to those listed on the enclosed *Notification List* within the deadlines specified above.

Failure to Publish and Submit Proof of Publication

You must meet all publication requirements. **If you fail to publish the notice or submit proof of publication, on time, the TCEQ may suspend further processing on your application or take other actions.**

Application at the Regional Office

- You must provide a copy of the administratively complete application to the appropriate regional office that has jurisdiction over the county in which the plant is to be located. The application must be available for review and copying by the public.
- The administratively complete application must be available beginning the first day of newspaper publication and remain available until the end of the public hearing, which is the length of the public comment period.
- If the application is submitted to the TCEQ with information marked as confidential, you are required to indicate which specific portions of the application are not being made available to the public. These portions of the application must be accompanied with the following statement: "Any request for portions of this application that are marked as confidential must be submitted in writing, pursuant to the Public Information Act, to Texas Commission on Environmental Quality, Public Information Coordinator, MC-197, P.O. Box 13087, Austin, Texas 78711-3087."

General Information

When contacting the Commission regarding this application, please refer to the Registration Number at the top of the Notice of Application.

If you wish to obtain an electronic copy, please contact the technical reviewer who assisted in the preparation of this public notice package. The electronic copy will consist of the example notice, the equivalent in Spanish (if applicable), and the instructions. The electronic version is available in Microsoft Word format only and can be requested once your application has been declared administratively complete.

If you have questions or need assistance regarding publication requirements, please contact the Office of the Chief Clerk at (512) 239-3300 or the technical reviewer listed in the cover letter.

TCEQ-Office of the Chief Clerk
MC-105 Attn: Notice Team
P.O. Box 13087
Austin, Texas 78711-3087

Applicant Name: Wilbarger Humane Society
Permit No.: 184013
Application Received Date: May 11, 2026

AFFIDAVIT OF PUBLICATION FOR AIR PERMITTING

STATE OF TEXAS §

COUNTY OF _____ §

BEFORE ME, the undersigned authority, on this day personally appeared

_____, who being by me duly sworn, deposes and says that (s)he is *(Name of Person Representing Newspaper)*

the _____ of the _____
(Title of Person Representing Newspaper) *(Name of the Newspaper)*

that said newspaper is generally circulated in _____, Texas;
(The municipality or nearest municipality to the location of the facility or the proposed facility)

that the enclosed notice was published in said newspaper on the following date(s):

(Newspaper Representative's Signature)

Subscribed and sworn to before me this the _____ day of _____, 20____
to certify which witness my hand and seal of office.

[Affix Seal]

Notary Public in and for the State of Texas

Print or Type Name of Notary Public

My Commission Expires

TCEQ-Office of the Chief Clerk
MC-105 Attn: Notice Team
P.O. Box 13087
Austin, Texas 78711-3087

Applicant Name: Wilbarger Humane Society
Permit No.: 184013
Application Received Date: May 11, 2026

ALTERNATIVE LANGUAGE AFFIDAVIT OF PUBLICATION FOR AIR PERMITTING

STATE OF TEXAS §

COUNTY OF _____ §

BEFORE ME, the undersigned authority, on this day personally appeared

_____, who being by me duly sworn, deposes and says that (s)he is (*Name of Person Representing Newspaper*)

the _____ of the _____;
(*Title of Person Representing Newspaper*) (*Name of the Newspaper*)

that said newspaper is generally circulated in _____, Texas;
(*The municipality or county in which the facility or proposed facility is located*)

that the enclosed notice was published in said newspaper on the following date(s):

(*Newspaper Representative's Signature*)

Subscribe and sworn to before me this the _____ day of _____, 20____
to certify which witness my hand and seal of office.

Notary Public in and for the State of Texas

[Affix Seal]

Print or Type Name of Notary Public

My Commission Expires

Notification List

It is the responsibility of the applicant to furnish the following offices with copies of the notices published, the *Affidavit of Publication for Air Permitting*, the *Alternative Language Affidavit of Publication for Air Permitting (if applicable)*, and a completed copy of the *Public Notice Verification Form (Form TCEQ-20546)*. Acceptable proof of publication and any affidavits and Form TCEQ-20546 should be emailed to PROOFS@tceq.texas.gov or mailed to the Texas Commission on Environmental Quality, Office of the Chief Clerk, MC-105, P.O. Box 13087, Austin, Texas 78711-3087.

Electronic copies should be submitted via email to the U.S. Environmental Protection Agency (EPA), **Region 6** at R6AirPermitsTX@EPA.gov. Please contact Ms. Aimee Wilson (wilson.aimee@epa.gov) at (214) 665-7596 if you have any questions pertaining to electronic submittals to the EPA.

Email copies to Mr. Rory Ashurst at Rory.Ashurst@tceq.texas.gov

Hard copies should be sent to the following:

Texas Commission on Environmental Quality
Abilene Regional Office
1977 Industrial Boulevard
Abilene, Texas 79602-7833

For TCEQ Use Only

**Permit Application Routing and Summary Sheet
Air Permits**

This sheet should accompany all notices to be processed by the office of the chief clerk on the left side of the file folder.

Name of applicant: Wilbarger Humane Society	
Facility/ Site name: Wilbarger Humane Society	
TCEQ permit number: 184013	
Application received date: May 11, 2026	
Customer reference number: CN606511434	
Regulated entity number: RN112446729	
County: Wilbarger	Region: 3
Local program 1:	Local program 2:
Permit type: Standard Permit Application	
Internal program routing	
Tech. team leader: Mr. Rory Ashurst	Phone no. (512) 239-3364
APIRT team leader: Nancy Birdsong	Date: May 13, 2026
Administratively reviewed by: Kimberly Cunningham	Phone no. (512) 239-1114
Administratively complete date: May 13, 2026	
Public viewing location must have internet access: <input type="checkbox"/> Yes <input checked="" type="checkbox"/> No	
Is 2nd public notice required: <input type="checkbox"/> Yes <input checked="" type="checkbox"/> No	
*Other	

For TCEQ Use Only

Applicant and Contact Information

This sheet should accompany all notices to be processed by the office of the chief clerk on the right side of the file folder.

Applicant's main contact and address to be shown on permit:	
Name/Title: Robert Webb, Owner	
Company: Wilbarger Humane Society	
Street/Road: 2805 Sullivan St	
City/State/Zip: Vernon, TX 76384-3316	
Telephone: (940) 839-5825	Fax:
Applicant's technical representative/ consultant:	
Name/Title: Luis Llorens Jr, President Project Manager	
Company: AI Environmental Consulting Services Inc US Cremation Equipment	
Street/Road: 2814 Silver Star Rd	
City/State/Zip: Orlando, FL 32808-3938	
Phone: (407) 923-9345	Fax: (321) 282-7358
Person responsible for publishing notice:	
Name/Title: Robert Webb, Owner	
Company: Wilbarger Humane Society	
Street/Road: 2805 Sullivan St	
City/State/Zip: Vernon, TX 76384-3316	
Telephone: (940) 839-5825	Fax:

Comisión de Calidad Ambiental de Texas



AVISO DE SOLICITUD DE UN PERMISO ESTÁNDAR DE CALIDAD DEL AIRE PARA UN INCINERADOR DE RESTOS DE ANIMALES

NO. DE REGISTRO DE CALIDAD DEL AIRE PROPUESTO: 184013

SOLICITUD. La Wilbarger Humane Society, localizada en 2805 calle Sullivan, Vernon, Texas 76384-3316 ha solicitado a la Comisión de Calidad Ambiental de Texas (la TCEQ) un Permiso Estándar de Calidad del Aire con no. de registro 18403, el cual autorizaría la construcción de un incinerador de restos de animales. Se propone ubicar dicha instalación en 2805 calle Sullivan, Vernon, Texas 76384-3316 Condado de Wilbarger, Texas. Se ofrece el siguiente enlace a un mapa electrónico de la ubicación general del sitio o instalación como una cortesía pública, el cual no forma parte de la solicitud o del aviso:

<https://gisweb.tceq.texas.gov/LocationMapper/?marker=-99.298388,34.162977&level=13> .

Favor de consultar la solicitud para conocer la ubicación exacta. Esta solicitud se envió a la TCEQ el día 11 de mayo del 2026. La función principal de esta instalación es la eliminación adecuada de restos de animales a través de la incineración. La directora ejecutiva determinó que la solicitud está administrativamente completa el día 13 de mayo del 2026.

COMENTARIOS PÚBLICOS. Es posible presentar comentarios públicos por escrito sobre esta solicitud en cualquier momento durante el periodo de comentarios públicos, el cual inicia en la fecha de publicación del aviso y se extiende a los 30 días posteriores a dicha fecha. Los comentarios públicos pueden enviarse por escrito a la siguiente dirección: Texas Commission on Environmental Quality, Office of the Chief Clerk, MC-105, P.O. Box 13087, Austin, Texas 78711-3087, o bien electrónicamente a través de www14.tceq.texas.gov/epic/eComment/. Favor de tener en cuenta que cualquier información de contacto proporcionada (nombre, teléfono, dirección física y de correo electrónico inclusive) pasará a formar parte de los registros públicos de la agencia.

RESPUESTA A COMENTARIOS. Tras la conclusión del periodo de comentarios, la directora ejecutiva preparará una respuesta por escrito a todos los comentarios relevantes, la cual se enviará (junto con la decisión de la directora ejecutiva sobre la solicitud) a todas las personas que hayan presentado comentarios y hayan solicitado ser parte de la lista de correo. La respuesta a comentarios se publicará en el archivo del permiso para su visualización.

La directora ejecutiva aprobará o denegará la solicitud a más tardar dentro de los 30 días posteriores a la conclusión del periodo de comentarios públicos (tomando en cuenta todos los comentarios recibidos dentro de dicho periodo) y basará esta decisión en si la solicitud cumple con los requisitos del permiso estándar

LA OFICINA CENTRA/REGIONAL. La solicitud estará disponible para su consulta y copia en la Oficina Central de la TCEQ y en la Oficina Regional de la TCEQ Abilene ubicada en 1977 Industrial Boulevard, Abilene, Texas 79602-7833 Condado de Taylor, Texas en horario de atención (lunes a viernes de 8:00 a. m. a 5:00 p. m.), a partir del primer día de la publicación de este aviso.

INFORMACIÓN. Para más información sobre el proceso de tramitación de permisos, favor de llamar al Programa de Educación pública de la TCEQ sin costo al 1-800-687-4040, o bien visitar su sitio web, www.tceq.texas.gov/goto/pep. Para información en español, favor de llamar al 1-800-687-4040. También es posible consultar oportunidades de participación pública en nuestro sitio web, www.tceq.texas.gov/goto/participation.

Es posible obtener más información del Wilbarger Humane Society por correo a la siguiente dirección: 2805 calle Sullivan, Vernon, Texas 76384-3316, o bien mediante llamada al Sr. Luis Llorens, President de AI Environmental Consulting Services, Inc. Teléfono 407-923-3945.

Fecha de emisión de este aviso: 13 de mayo de 2026

Wilbarger Humane Society

Proposed Crematory Site



Imagery ©2026, Map data ©2026 Google 200 ft

US Cremation Equipment Model
 US 75/300 Gen II
 Animal Crematory AKA Sierra 300

Equipment	Pounds Incinerated Per Hour (Average)	Hours Per Year	SO2 lb/ton	SO2 lb/hr	SO2 TPY	Nox lb/ton	Nox lb/hr	Nox TPY	TOC lb/ton	TOC lb/hr	TOC TPY	PM lb/hr	PM TPY	CO lb/hr	CO TPY
US 75/300 Gen II aka Sierra 300	75	8760	2.5	0.09375	0.410625	3	0.1125	0.49275	3	0.1125	0.49275	0.05	0.23	0.01	0.04
Facility-Wide Emissions(1)				0.09375	0.410625		0.1125	0.49275		0.1125	0.49275	0.03	0.13	0.01	0.04

CO=100 PPM @ 7% O2 based on manufacturers warranty

PM = 0.08 gr/dscf based on manufacturers warranty

US 75/300 Animal Crematory, CO is calculated as follows:

5.03 PPM 7% X 444 SCFMD X 2.595E-9 X 28 MW x 60 min/hr = 0.01 lb/hr CO
 0.01 X 8760 hrs/yr X 1 ton/2000lbs = 0.04 TPY CO Based on Stack test data

US 75/300 Animal crematory, PM is calculated as follows:

0.008 gr/dsf 7% X 444 SCFMD X 60 min/hr X 1lb/7000 Grains = 0.03 lb/hr
 0.03 lb/hr PM x 8760 hrs/yr x 1 ton/2000 lbs = 0.13 TPY PM

The above data (CO and PM) was calculated using data from the provided stack test (3 run AVG. for CO and PM only).

Process Flow Diagram

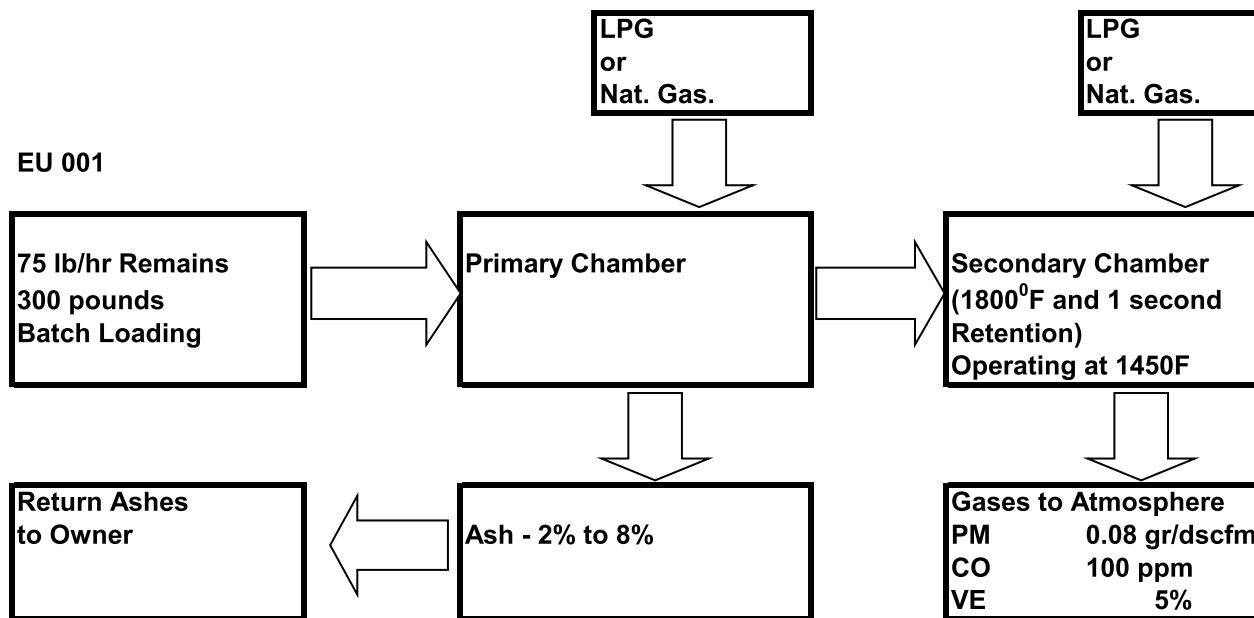

Wilbarger Humane Society

Correct Site Address is 2805 Sullivan St. Vernon, TX 76384

Legend

- 📍 2801 Sullivan St
- 📍 CEFCO Travel Center
- 📍 Proposed Crematory Site
- 📍 Toro Japanese Restaurant
- 📍 Wilbarger Humane Society

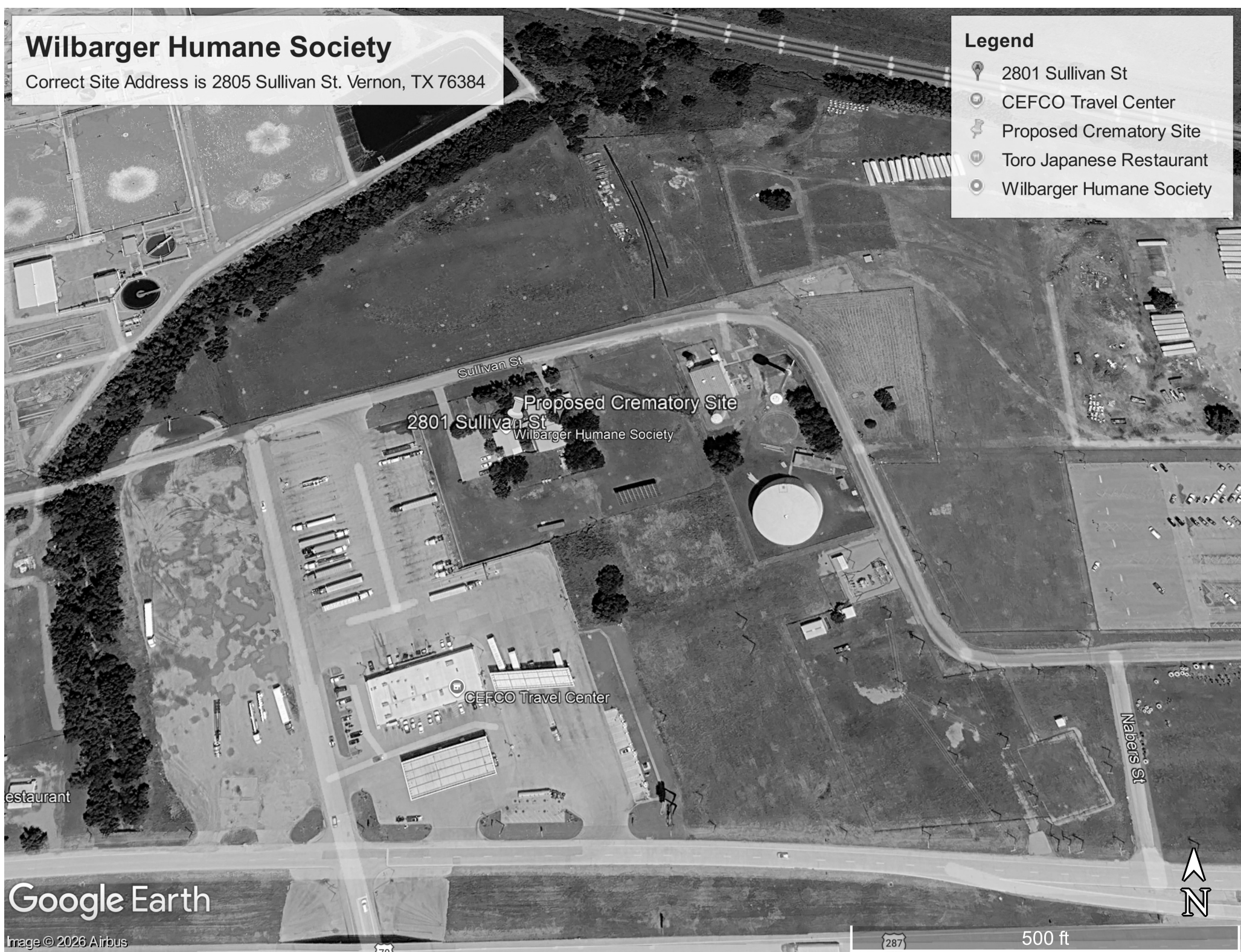

Google Earth

Image © 2026 Airbus

287

500 ft





*Air Permit -Standard Permit
Wilbarger Humane Society
2805 Sullivan Street
Vernon, TX 76384
Wilbarger County*

Prepared By:

*AI Environmental Consulting Services, Inc./U.S. Cremation Equipment
2814 Silver Star Road, Suite 201-D
Orlando, Florida 32808
Phone 321-282-7357
Email AI@CFL.RR.COM*

April 2026

Application Information and Notes

Project Description:

This application seeks a Permit by Rule (standard permit) for the installation of a new U.S. Cremation Equipment model US 75/300, also known as the Sierra 300 Animal Crematory, at the Wilbarger Humane Society, located at 2805 Sullivan Street, Vernon, TX 76384, in Wilbarger County. This is a new crematory at a new facility and complies with the 50-ft setback requirements for a standard permit.

Compliance History:

Stack Sampling Ports & Facilities: Stack testing of the crematory is not expected to be required based on identical source stack testing results. US 75/300 Gen II aka Sierra 300 Criteria pollutant emission estimates are based on AP-42 Table 2.1-12, Uncontrolled Emission Factors for Refuse Combustors Other Than Municipal Waste.

Protection of Public Health and Welfare:

Based on similar source stack test and manufacturer-supplied data, the emissions from the proposed facility will comply with the rules and regulations of the Commission, including protection of the health and physical property of the people.

Title 40 CFR Part 60: The source is not applicable to NSPS.

Title 40 CFR Part 61: The source is not applicable to NESHAP.

Title 40 CFR Part 63: The source is not applicable to MACT.

Performance Demonstration:

Stack testing of the crematory is not expected to be required.

In accordance with TCEQ Rule 111.121(1), the PM emission concentration should be less than 0.08 gr/dscf, corrected to 7% O₂ (total PM 0.16 gr/dscf), based on the similar source stack test included in Appendix IV. In accordance with TCEQ Rule 111.121(3), the CO emission concentration will not exceed 100 ppm by volume (dry basis), corrected to 7% O₂, based on the similar source stack test included.

Nonattainment review:

Emission levels are not of the magnitude to trigger nonattainment review.

Prevention of Significant Deterioration (PSD) review: Due to the emission levels PSD is not applicable.

Air Dispersion Modeling:

Based on the emission levels and nature of the surrounding environment, dispersion modeling is not warranted.

Hazardous Air Pollutants (HAPs):

Emission of HAPs from the cremation of animal cremators are insignificant.

It is the intent of the Wilbarger Humane Society to comply with applicable portions of 30 TAC Chapter 116 "Control of Air Pollution by Permits for New Construction or Modifications". Additional information pertaining to compliance with 30 TAC Chapter 116 is provided below:

30 TAC Chapter 116.112 does not apply to this facility.

30 TAC Chapter 116.115 "General and Special Conditions"

It is the intent of Wilbarger Humane Society to comply with the applicable permit General Conditions and those Special Conditions, which have been reviewed by our air, permit engineer and have been deemed absolutely necessary by the TCEQ.

30 TAC Chapter 116.116 "Changes to Facilities"

It is the intent of Wilbarger Humane Society to comply with the applicable portions of 30 TAC Chapter 116.116 should changes to the facility are proposed.

30 TAC Chapter 116.117 "Documentation and Notification of Changes to Qualified Facilities"

It is the intent of Wilbarger Humane Society to comply with the applicable portions of 30 TAC Chapter 116.117 should proposed changes fall within the definition of Qualified Facilities in 30 TAC Chapter 116.116(e).

30 TAC Chapter 116.118 "Pre-change Qualification"

Should facility conditions exist and facility changes are proposed which require the facility to obtain pre-change qualifications, it is the intent of Wilbarger Humane Society to comply with the applicable portions of 30 TAC Chapter 116.118.

It is the intent of the Wilbarger Humane Society to comply with the applicable portions of 30 TAC Chapters 111, 112, 113, 115, 117, 118, and 122.

Chapter 111 Control of Air Pollution from Visible Emissions and Particulate Matter

Particulate emissions shall not exceed 0.18 gram per dry standard cubic meter (g/dscm) or 0.08 grains per dry standard cubic foot (gr/dscf), front-half of sampling train only, when corrected for 7.0% oxygen (O₂) in the stack gas according to the formula. Carbon monoxide (CO) emissions shall not exceed 100 parts per million by volume dry basis, when corrected to 7.0% O₂ in the stack gas. Oxygen content shall be maintained at greater than 4.0% by volume of the emissions of the incinerator, measured at the exit of the incinerator. Visible emissions shall not exceed opacity of 5.0% averaged over any six-minute period.

Based on the Source Emission Test Report the model US 75/300 aka Sierra 300 can maintain a Secondary Combustion Chamber temperature in excess of 1800 degrees Fahrenheit and 1.0 second residence time during actual conditions. Actual operating temperature shall be from 1400⁰F to 1600⁰F.

The source does not burn Hazardous Waste Fuels.

RULE §111.127 Monitoring and Record keeping Requirements

A Partlow MRC 5000 chart recorder or equivalent is going to record the secondary chamber temperature.

Chapter 112 Control of Air Pollution from Sulfur Compounds

Chapter 112 Control of Air Pollution from Sulfur Compounds is not applicable to this source.

Chapter 113 Standards of Performance for HAPs and for Designated Facilities

Chapter 113 Standards of Performance for HAPs and for Designated Facilities and pollutants is not applicable to this source. Animal crematories are not one of the designated sources under Subchapter D Designated Facilities and Pollutants.

Chapter 115 Control of Air Pollution from Volatile Organic Compounds

Chapter 115 Control of Air Pollution from Volatile Organic Compounds is not applicable to this source.

Chapter 117 Control of Air Pollution from Nitrogen Compounds

Chapter 117 Control of Air Pollution from Nitrogen Compounds is not applicable to this source. An animal crematory is not considered a water heater, small boiler, or process heater as they are defined in Subchapter D Small Combustion Sources.

Chapter 122 Federal Operating Permits

This source is not a Major Source of air pollution or a Synthetic Minor Source of air pollution. It is a minor source of air pollution, which may be applicable to TCEQ rules and regulations. Chapter 122 Federal Operating Permits is not applicable to this source as the source does not need to limit it's potential to emit.

Distribution - Copies of the Application were file using TCEQ STEERS software.



Pet Cremator "Sierra 300"



Random-Load Pet Cremation Systems

Model: Sierra-300 (US 75/300 Gen II)

Load Capacity: 300 lbs

Processing Rate: 75 lbs/hr

Perfectly equipped for the typical veterinary practice or beginning pet cremation service. Ideally sized to accommodate "private" pet cremations, yet large enough to provide the ample capacity needed to perform "partitioned" and "communal" cremations. Smokeless and odorless operation, UL Listed for safety, fully automatic controls and many more features that offer convenient, efficient and safe operation for your staff and business.

US Cremation Equipment - Features and Benefits Summary

- **No Cool-Down Required between Cremations:** You can process one-pet-after-another without the need to cool-down between the private pet cremations.
- **Powder Coat Finish:** Superior to painting, the powder coating process bonds the colors to the metal through a heat treating process, rather than simply covering the metal as painting does.
- **Dual Piston Hydraulically Actuated Door:** Our dual-piston design guides the door steadily and smoothly into the desired position and it is extremely safe for your operators ... there is no possibility for a chain to break, allowing the door to free-fall at the time of failure.
- **Mechanically Sealed Loading Door:** Our unique door-track system, working in concert with the dual-pistons, mechanically presses our door against the steel bulk-head, resulting in a tight 360° seal.
- **Two Year Warranty:** Each of our crematories carries a two year warranty, which is twice as long as the standard warranty that other manufacturers offer.
- **Low Profile Exhaust Stack:** Helpful in neighborhoods where a tall protruding stack may not be allowed by zoning, or is aesthetically unappealing and could be offensive to neighbors.
- **Wide Primary Chamber:** Allows your staff to safely and conveniently load larger animals as well as provides a greater area in which to perform “partitioned” and “communal” cremations.
- **Monolithically Cast Refractory Secondary Chamber:** Extremely durable fabrication technique, leading to the extended useful life of the equipment and less down-time, as well as lower maintenance costs.
- **Removable External Side-Skins:** Our external skins are easily removed should you ever need to access the internal workings for inspection or repair. Other manufacturers weld their skins in place to expedite the manufacturing process, making removal costly and damaging to the machine.
- **Rear-Mounted Electrical Panel and Components:** Protects components from the heat that radiates from the top of the machine, reducing component failure and extending the useful life of the cremator. Most manufacturers place their components on top, shortening their useful life and making maintenance difficult.
- **Refractory Lined Draft Inducer:** This device cools the exhaust stream and also allows your staff to safely load or clean-out at any time during the cremation process, thus reducing your time to complete your daily work-load.
- **Stainless Steel Anchors:** Restricts the movement of the walls (from expansion/contraction), extending the useful life of the chamber, reducing your down-time and lowering maintenance costs.
- **Underwriters Laboratories (UL) Certifications:** Our entire cremator (not just component parts or electrical panels) has been independently tested by UL and has received their coveted “Listed” status. This UL listing may help with your insurance coverage and rates.

We Sell The Best ... And Service The Rest



ANIMAL CREMATION CHAMBER SPECIFICATION

Model US 75/300 (Gen 2) aka Sierra 300

EQUIPMENT:

U.S. Cremation Equipment, a division of American Incinerators Corporation - Multiple Chambered Animal Cremator; Natural Gas, Propane (LP) or Oil fired.

MANUFACTURER:

U.S. Cremation Equipment a division of American Incinerators Corporation.

CONSTRUCTION STANDARDS:

The cremator shall be constructed of U.L./CSA listed components and will meet or exceed nationally accepted incinerator construction standards per the Incinerator Institute of America (IIA) publication guidelines; i.e.:

- A. Primary chamber will not exceed 60% of total furnace volumes. Flue connection shall not be considered part of furnace volume.
- B. Flame supervision through continuous ultraviolet scanning flame detectors on all burners.
- C. High temperature refractory construction with air-cooled walls to prevent excessive heat radiation.
- D. Exhaust gas temperature reduction.

SAFETY CERTIFICATIONS

Underwriters Laboratories (UL) listed appliance File number: MH47704 ID:3UP5

CREMATOR DIMENSIONS:

Chamber volumes:	Primary - 38 CF	(1.08 CM)
	Secondary - 42.5 CF	(1.20 CM)
Primary Chamber:	71 "L x 38" W x 32 " H	
Structural footprint:	145" L x 64" W(2868 mm x 1575 mm)	
Over-all dimensions:	154 L x 64" W (74" W/Touch Screen) x 101"H	

OPERATING TEMPERATURE:

Temperatures are determined as a result of federal, state or local permitting authority operating standards.

Typical primary chamber setting: 1,000°F-1,200°F (538 C - 648 C)
Typical secondary chamber setting: 1,400°F-1,800°F (760 C - 982 C)

POWER CHARGING DOOR:

Door Height: 36.5" (927 mm)
Door Width: 42" (1067 mm)

PRIMARY CHAMBER OPENING:

Width: 38" (965 mm)
Height: 30.00" (762 mm)

RETENTION TIME:

In excess of 1 second.

CAPACITY RATING:

75 lb/hr for type 4 waste. Single load capacity of 300 lbs per cremation cycle

DRAFT:

Induced via refractory lined draft inducer.

SHIPPING WEIGHT:

22,000 lbs. (9979 kg) Estimated

EMISSIONS:

The U. S. Cremation Equipment animal cremator shall meet or exceed federal, state/province and local environmental regulations.

EMISSION CONTROL:

Secondary chamber equipped with one, 1,500,000 BTU/HR burner. Also equipped with an electronic exhaust gas scanner system which temporarily suspends operation of the primary chamber burner if the opacity of the exhaust gases reach 20%.

STEEL CONSTRUCTION SPECIFICATIONS:

- A. The structure to be heavy 3" steel angle , square tube; 3/8" steel plate, seal welded construction.
- B. Subfloor to be 3/16" steel plate, seal welded construction.
- C. The exterior shell to be 14 gauge steel removable panels.
- D. Interior shell to be 12 gauge steel, seal welded construction.

INSULATION & REFRACTORY SPECIFICATIONS:

- A. Hot Hearth: 3000°F abrasion resistant castable refractor monolithic cast 7" - 13" thick, 1 -1/2" recessed top and rounded, stressed arched bottom.
- B. Chamber Floors: 3000°F abrasion resistant castable refractory, 5" thick on top of 2" 2400°F light weight insulating castable.
- C. Chamber Ceilings: 3000°F castable refractory, monolithic cast, rounded, stressed arched, 5"-9" thick, topped by 2" 2400°F light weight insulating castable.
- D. Interior Walls: 2800°F. castable refractory, 4 1/2" x 9", all chambers are backed by 4" of 1900°F ceramic fiber insulation
- E. Stack: Lined with 3" of 2200°F insulating refractory plus ¼ insulating paper.

SKIN TEMPERATURE CONTROL:

Integral dual casing, completely air-cooled design to prevent excessive heat radiation.

COMBUSTION EQUIPMENT:

- A. Combustion Air - One (1) single phase, 208-230/460V, 17-15.5/7.6 amp, 5 hp air-blower motor (1200 CFM/34 CMM). Three Phase available.
- B. Primary Chamber - One 500,000 BTU/HR nozzle mix, gas-fired burner. Eclipse, North American, or equal.
- C. Secondary Chamber - One, 1,500,000 BTU/HR modulating, nozzle mix, gas-fired burner. Eclipse, North American, or equal.
- D. Burner Flame Safeguard - Control supervision on each burner via a flame safeguard relay and ultra-violet scanner.
- E. Low Air Pressure Safety Switch - Interlocked to all burners.

EXHAUST GAS TEMPERATURE REDUCTION:

Hot air duct operating exit temperature: 900° F to 1200 ° F (482 C - 649 C)

HOT AIR DUCT:

10 gauge carbon steel, high temperature 3" refractory lining plus insulating paper (51 -76 mm), pre-drilled flanges, 24" Outside Diameter, 28" (711 mm) at flanges.
Weight 550 lbs per 4 ft section (250 kg).

UTILITY REQUIREMENTS:

A. GAS:

1. Pressure:
 - a) Natural Gas: 7" to 9" W.C. (178 mm to 228 mm)
 - b) Propane: 11" W.C. (288 mm)
2. Flow Rate: 2,000,000 BTU/hr

B. ELECTRICAL:

1. One (1) 3 Phase, 208-230 Volts, 50/60 Hz for 5 hp air blower. Single phase available.

CREMATION CHAMBER LOADING/CLEAN-OUT DOOR:

Hydraulically operated, refractory lined, upward movement guillotine style door
W/Primary Chamber View Port

CREMATION PROCESS CONTROL:

The cremation cycle is controlled by a programmable logic control (PLC) system. A visual confirmation of the system status is provided through control panel indicator lights and digital temperature display. Continuous fuel and air modulation is automatically controlled by a time/temperature actuated system. Operator interface is through two sets of simple push button controls and panel timer.

The cremation chamber is finished with grey hi-resistance powder coating. Back and top of unit is coated with epoxy type black paint. Loading door is trimmed in stainless steel.

MATERIAL CALL OUT: PER INDIVIDUAL DRAWINGS

WEIGHT: lbs QTY: 1 JOB#

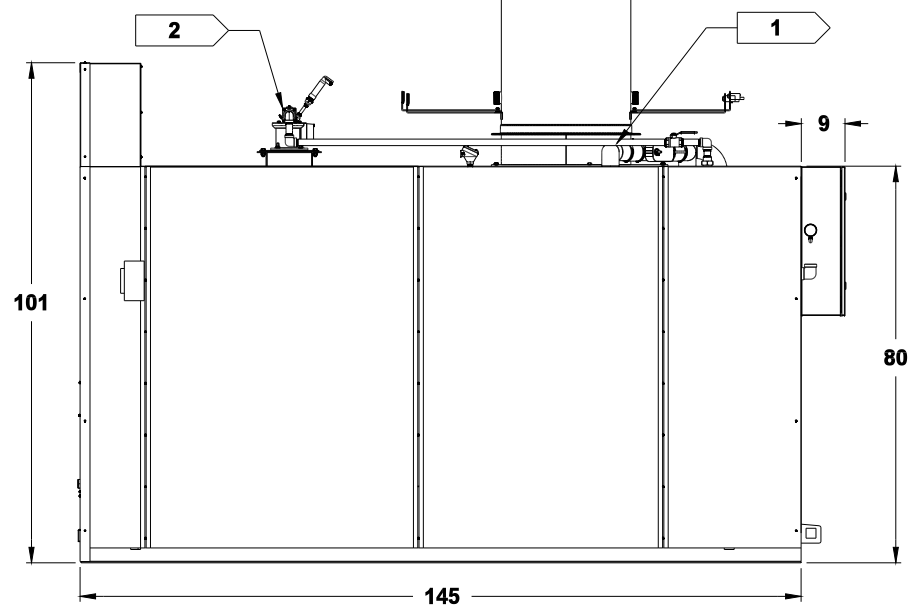
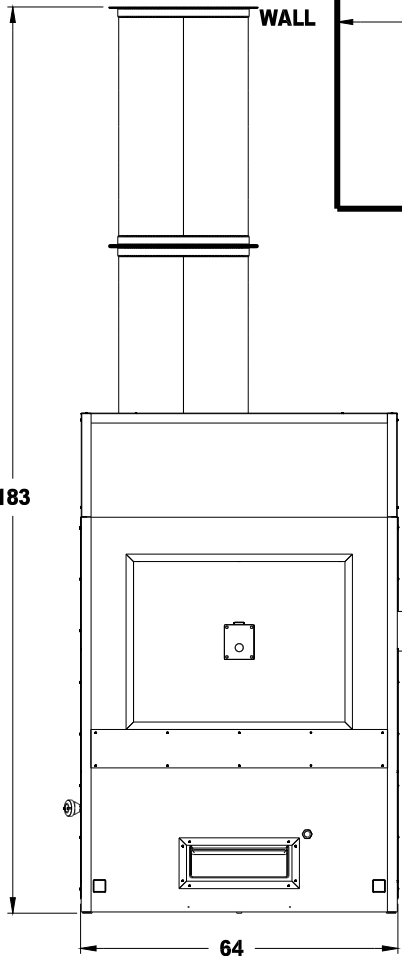
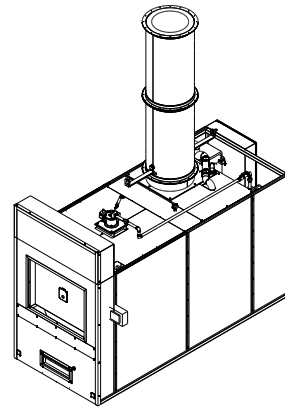
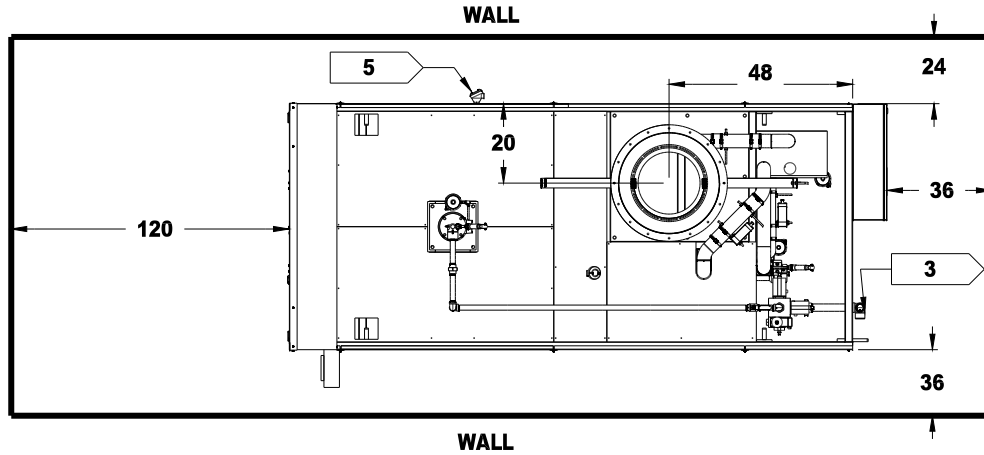

- 1. HEIGHT FROM FLOOR TO DRAFT INDUCER = 87"
- 2. HEIGHT FROM FLOOR TO TOP OF BURNER = 92"
- 3. GAS INLET
- 4. SCREEN MAY BE INSTALLED ON L OR R SIDE
- 5. SECONDARY THERMOCOUPLER MAY BE INSTALLED ON FRONT
- 6. DRAFT INDUCER & PRIMARY GAS TRAIN MAY BE STRIPPED FOR SMALLER ENTRYWAYS (ADDL CHARGE).

REV	ECN#	MADE BY	DESCRIPTION	DATE
0	---	SKL	INITIAL RELEASE	8.10.18
REVISION HISTORY				

NOTES:

ALL DIMENSIONS ARE IN INCHES UNLESS OTHERWISE SPECIFIED
 DO NOT SCALE DRAWING
 TOLERANCES UNLESS OTHERWISE SPECIFIED
 XXX ± .005 FRAC ± 1/32
 XX ± .010 CHAM 1/64 X 45°
 X ± .015 ANGLE ± 1/2°
 RAD. 1/16 R FINISH: 125 RMS
 EDGE BREAK .005-.015 EXCEPT WHERE NOTED

PROPRIETY NOTICE
 US CREMATION EQUIPMENT
 Claims proprietary rights in the material disclosed hereon. This drawing is issued for engineering information only. It may not be reproduced, nor the information hereon be used for manufacturing purposes without written permission from US CREMATION EQUIPMENT

U.S. CREMATION EQUIPMENT 528 Northlake Blvd. #1040 Altamonte Springs, FL 32701		DESCRIPTION
DRAWN BY: S.LAFLEUR	8.10.18	US-75-300/SIERRA 300 ELEVATION ASSEMBLY
CHECKED BY:		
APPROVED BY:		
PART NO. USCE-75300-9300-ELEV-ASSY		
DWG #		SHEET: 1 OF 1

**Source Test Report for
Particulate, Carbon Monoxide
& Visible Emissions**

Report 24011-ST

Conducted:

February 2, 2024

Prepared For:

Rest Assured Animal Cremations, LLC

Charlotte, NC

Performed At:

U.S. Cremations Equipment

Orlando, FL Manufacturing Facility

By:

Beatty Environmental Services Inc.

315 SE 20th Place

Cape Coral, FL 33990

(239) 246-3646



Table of Contents

Section	Page
1.0	Introduction..... 1
2.0	Certification of Test Results 2
3.0	Allowable Emission Determination 3
4.0	Cyclonic Flow Determination 4
5.0	Summary of Results 5
6.0	Particulate Emission Results 6
7.0	Visible Emission Results 7
8.0	Carbon Monoxide Results.....8
9.1	Overview of Field and Analytical Procedures..... 9
9.2	EPA Method 1..... 9
9.3	EPA Method 2..... 9
9.4	EPA Method 3..... 9
9.5	EPA Method 4..... 9
9.6	EPA Method 5..... 10
9.7	EPA Method 9..... 10
9.8	EPA Method 10 10
10.0	Sampling Point Determination Procedure11
10.1	Sampling Point Determination.....12
11.0	Summary of Field and Laboratory Data.....13
	Attachment A - Field Data
	Attachment A -- Laboratory Data
	Attachment C - Process Data and Plant Data
	Attachment D - Calculations for Run 1
	Attachment E - Calibration Data
	Attachment F - Project Participants

1.0 Introduction

On February 2, 2024, EPA Methods 1-5, 9 & 10 testing for Particulate Matter (PM), Visible Emissions (VE) and Carbon Monoxide (CO) was performed on a U.S. Cremation Equipment Animal Cremator **Model** US 75/300(Gen 2) AKA Sierra 300, located at 2814 Silver Star Road Bldg 201-D in Orlando, Florida. The animal cremation unit is being installed at Rest Assured Animal Cremations, LLC located at 618 Rountree Road in Charlotte, North Carolina.

During the testing period, Luis Llorens of U.S. Cremation Equipment maintained a log containing the emission control device and process data. This information is presented, along with the temperature chart, in Attachment C.

The results of this test verify compliance with the rules as set forth by Florida Department of Environmental Protection referenced under CFR Part 62-296.401 for incinerators.

2.0 Certification of Test Results

Testing For: Rest Assured Animal Cremations, LLC
Model #US 75/300(Gen 2) AKA Sierra 300
618 Rountree Road
Charlotte, North Carolina 28217

Testing Location: U.S. Cremations Equipment
2814 Silver Star Road 201-D
Orlando, Florida 32808

Type Process Animal Cremation

Abatement Device Afterburner

Report 24011-ST

Date February 2, 2024

Actual Particulate Matter Emissions (gr/dscf @ 7% O2) -	0.008
Allowable Particulate Emissions (gr/dscf @ 7% O2) -	0.08
Actual Visible Emission (VE) (Highest six minute average %) -	0.00
Allowable Visible Emission (VE) (Highest six minute average %) -	5.00
Actual Carbon Monoxide Emissions (CO @ 7% O2) -	5.03
Allowable Carbon Monoxide Emissions (CO @ 7% O2) -	100.00

I hereby certify that to my knowledge, all information and data submitted in this report is true and correct.

Nicholas Decker

Nicholas Decker
Field Manager

3.0 Allowable Emission Determination

The allowable emissions were determined by permit specific conditions.

Substantiating data and calculations are presented in the Appendix D.

4.0 Cyclonic Flow Determination

EPA Method 1

“11.4.1 In most stationary sources, the direction of stack gas flow is essentially parallel to the stack walls. However, cyclonic flow may exist (1) after such devices as cyclones and inertial demisters following venturi scrubbers, or (2) in stacks having tangential inlets or other duct configurations which tend to induce swirling; in these instances, the presence or absence of cyclonic flow at the sampling location must be determined.”

Due to the configuration of the system, cyclonic flow was considered to be non-existent at the sampling site.

CYCLONIC FLOW DETERMINATION

EPA Method 1, Section 11.4

FACILITY NAME:

Rest Assured Animal Cremations, LLC

REPORT NUMBER

24011-ST

Facility ID

AVERAGE FLOW ANGLE:

0.0

CYCLONIC FLOW: (Yes/No)

No

(Note: Average flow angle must be less then 20 degrees)

Date: February 2, 2024

POINT NUMBER	FLOW ANGLE (DEG)	FLOW DIRECTION (PROBE ROTATION TOWARDS) (L, R)
1	0.0	-
2	0.0	-
3	0.0	-
4	0.0	-
5	0.0	-
6	0.0	-
7	0.0	-
8	0.0	-
9	0.0	-
10	0.0	-
11	0.0	-
12	0.0	-
1	0.0	-
2	0.0	-
3	0.0	-
4	0.0	-
5	0.0	-
6	0.0	-
7	0.0	-
8	0.0	-
9	0.0	-
10	0.0	-
11	0.0	-
12	0.0	-

IF DEG 0 NO Flow direction is needed.

Average = 0.0

5.0 Summary of Results
Rest Assured Animal Cremations, LLC

24011-ST

	Run 1	Run 2	Run 3	Average
Date	2/2/2024	2/2/2024	2/2/2024	
Start Time	8:20	9:55	11:20	
Stop Time	9:23	10:58	12:23	
Process Rate (lbs.)	79	129	130	113
Particulate Emission Rate (gr./dscf @ 7% O ₂)	0.0045	0.0069	0.0121	0.008
Allowable Particulate Emission Rate (gr./dscf @7% O ₂)	0.080	0.080	0.080	0.080
Visible Emission Rate (%) (highest six minute average)			0.00	
Allowable Visible Emission Rate (%)			5	
Carbon Monoxide Emission Rate (ppm @7% O ₂)	1.99	5.47	7.64	5.03
Allowable Carbon Monoxide Emission Rate (ppm @7% O ₂)	100	100	100	100

6.0 Particulate Emission Results
Rest Assured Animal Cremations, LLC

24011-ST

	Run 1	Run 2	Run 3
Area (square feet)	2.18	2.18	2.18
Stack Pressure (inches Hg)	30.04	30.04	30.04
Meter Pressure (inches Hg)	30.14	30.13	30.13
Sample Volume (Std. Cu. Ft.)	41.247	38.019	38.414
Water Vapor (Cubic Feet)	5.17	5.79	9.44
Sample Moisture (percent)	11.14	13.21	19.72
Saturation Moisture (percent)	100.00	100.00	100.00
Molecular Weight (lbs/lb Mole wet)	28.18	28.03	27.22
Velocity (fpm)	662	702	731
Volumetric Flow Rate (acfm)	1444	1533	1595
Volumetric Flow Rate (scfm-dry)	476	434	421
Concentration (gr/dscf)	0.0028	0.0050	0.0086
Concentration@7% O2 (gr/dscf)	0.0045	0.0069	0.0121
Mass Emission Rate (lbs./hr.)	0.01	0.02	0.03
Percent Isokinetic	102.83	104.09	108.45

7.0 Visible Emission Results

Rest Assured Animal Cremations, LLC

24011-ST

Emission Point	Allowable Emission Rate (highest six minute average)	Emission Rate (highest six minute average)	Average Opacity
Exhaust Stack	5	0.00	0.00

8.0 Carbon Monoxide Emission Results
Rest Assured Animal Cremations, LLC

24011-ST

	Run1	Run 2	Run 3	Average
Date	2/2/2024	2/2/2024	2/2/2024	
Start Time	8:20	9:55	11:20	
Stop Time	9:23	10:58	12:23	
Percent Oxygen	12.30	10.80	10.98	
Carbon Monoxide (PPM)	1.23	3.97	5.45	
Carbon Monoxide Emissions (PPM @ 7% O ₂)	1.99	5.47	7.64	5.03
Carbon Monoxide Allowable (PPM@7% O ₂)	100	100	100	100

8.0. Overview of Field and Analytical Procedures

8.1. EPA Method 1 - Sample and Velocity Traverses for Stationary Sources Principle -

To aid in the representative measurement of pollutant emissions and/or total volumetric flow rate from a stationary source, a measurement site where the effluent stream is flowing in a known direction is selected and the cross-section of the stack is divided into a number of equal areas. A traverse point is then located within each of these equal areas. See Sampling Point Determination.

Applicability - This method is applicable to flowing gas streams in ducts, stacks and flues. This method cannot be used when: 1) flow is cyclonic or swirling 2) a stack is smaller than about 12 inches in diameter, or 0.071 cross-sectional area or 3) the measurement site is less than two stack or duct diameters downstream or less than a half diameters upstream from a flow disturbance. The procedures in this method were utilized in its entirety according to the procedures outlined in 40 CFR Part 60, Appendix A.

8.2. EPA Method 2 - Determination of Stack Gas Velocity and Volumetric Flow Rate

Principle - Type S Pitot Tube - The average gas velocity in a stack is determined from the gas density and from measurement of the average velocity head with a Type S pitot tube.

Applicability - This method is applicable for measurement of the average velocity of a gas stream and for quantifying gas flow. This procedure is not applicable at measurement sites which fail to meet the criteria of Method 1. This method cannot be used for direct measurement in cyclonic or swirling gas streams. The procedures in this method were utilized in its entirety according to the procedures outlined in 40 CFR Part 60, Appendix A.

8.3. EPA Method 3 - Gas Analysis for the EPA Determination of Dry Molecular Weight

Principle - A gas sample is extracted from a stack by one of the following methods (1) A multi-point grab sampling method using an Orsat analyzer to analyze the individual grab sample obtained at each point; (2) a method for measuring either CO₂ or O₂ and using stoichiometric calculations to determine dry molecular weight; and (3) assigning a value of 30.0 for dry molecular weight, in lieu of actual measurements, for processes burning natural gas, coal, or oil.

Applicability - This method is applicable for determining carbon dioxide and oxygen concentrations and dry molecular weight of a sample from a gas stream of a fossil fuel combustion process. The method may also be applicable to other processes where it has been determined that compounds other than CO₂, O₂, CO, and nitrogen are not present in concentrations sufficient to affect the results. The procedures in this method were utilized in its entirety according to the procedures outlined in 40 CFR Part 60, Appendix A.

8.4. EPA Method 4 - Determination of Moisture Content in Stack Gases Principle -

A gas sample is extracted at a constant rate from the source; moisture is removed from the sample stream and determined either volumetrically or gravimetrically.

Applicability - This method is applicable for determining the moisture content of stack gas. There are two procedures given to determine the moisture. The procedure for the reference method to determine the moisture content was used to calculate the emission data. The reference method was conducted simultaneously with the pollutant emission measurement run, pollutant emission rate, etc. for the run is based upon the results of the reference method or its equivalent. The procedures in this method were utilized in its entirety according to the procedures outlined in 40 CFR Part 60, Appendix A.

9.5 EPA Method 5-Determination of Particulate Emissions from Stationary Sources

Principle - Particulate matter is withdrawn isokinetically from the source collected on a glass fiber filter maintained at a temperature in the range of 223-273 degrees F or such other temperature as specified by an applicable subpart of the standards or approved by the Administrator, US Environmental Protection Agency for a particular application. The particulate mass which includes any material that condenses at or above the filtration temperature is determined gravimetrically after removal of uncombined water.

Applicability - This method is applicable for the determination of particulate emissions from stationary sources. The procedures in this method were utilized in its entirety according to the procedures outlined in 40 CFR Part 60, Appendix A.

Diagram of EPA Method 5 Sampling Train

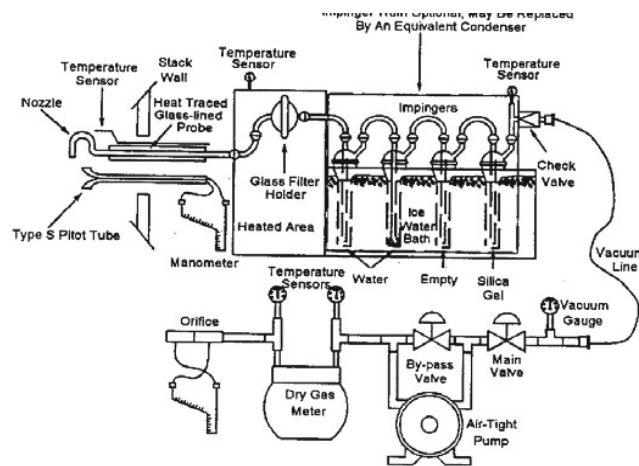

Figure F5-1. Particulate Sampling Train.

9.6 EPA Method 9 - Visual Determination of the Opacity of Emissions from Stationary Sources

Principle - The opacity of emissions from stationary sources is determined visually by a Qualified observer.

Applicability - This method is applicable for the determination of the opacity of emissions from stationary sources pursuant to 60.11(b) and for qualifying observers or visually determining the opacity of emissions.

9.7 EPA METHOD 10—Determination of Carbon Monoxide Emissions From Stationary Sources (Instrumental Analyzer Procedure)

Principle - In this method, you continuously or intermittently sample the effluent gas and convey the sample to an analyzer that measures the concentration of CO. You must meet the performance requirements of this method to validate your data.

Applicability - The use of Method 10 may be required by specific New Source Performance Standards, State Implementation Plans, and permits where CO concentrations in stationary source emissions must be measured, either to determine compliance with an applicable emission standard or to conduct performance testing of a continuous emission monitoring system (CEMS). Other regulations may also require the use of Method 10.

9.0 Sampling Point Determination Procedure

Minimum Number of Sampling Points Per Traverse

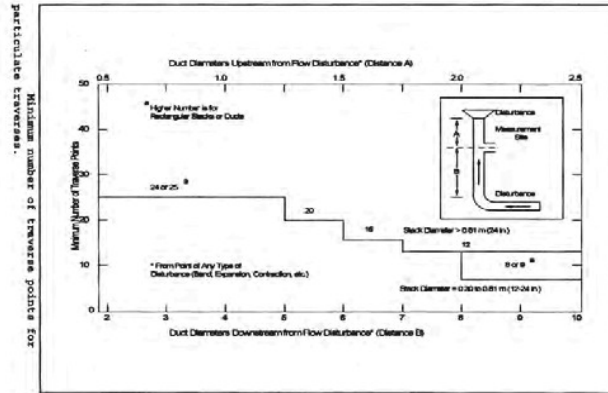

Circular Stacks

The number of sampling points is selected according to the above diagram, with the number of points equaling the next higher multiple of four.

Rectangular Stacks

The number of sampling points is determined using the matrix below.

Number of Traverse Points	Subarea Layout Matrix
9	3x3
12	4x3
16	4x4
20	5x4
25	5x5
30	6x5
36	6x6
42	7x6
49	7x7

9.1 Sampling Point Determination
Rest Assured Animal Cremations, LLC

24011-ST

Stack Configuration	Circular
Diameter (inches)	20
Distance A - Ports located upstream from disturbance (inches)	108
Distance A - Ports located upstream from disturbance (diameters)	5.4
Distance B - Ports located downstream from disturbance (inches)	86
Distance B - Ports located downstream from disturbance (diameters)	4.3
Number of Test Ports	2
Wall or Port length	0
Number of Sampling Points per Traverse	12
Number of Points Sampled	24

Photograph of Stack



Traverse Point Location	
Traverse Point No.	Inches to Sample Point offset
1	0.75
2	1.3
3	2.4
4	3.5
5	5.0
6	7.1
7	12.9
8	15.0
9	16.5
10	17.6
11	18.7
12	19.25

*Points 1 & 12 adjusted to meet EPA Method 1 requirements for duct diameters less than 24 inches.

10.0 Summary of Field and Laboratory Data
 Rest Assured Animal Cremations, LLC

24011-ST

	Run 1	Run 2	Run 3
Date	2/2/2024	2/2/2024	2/2/2024
Start Time	8:20	9:55	11:20
Stop Time	9:23	10:58	12:23
CP	0.84	0.84	0.84
Y	0.9998	0.9998	0.9998
^Ha (inches H2O)	1.6830	1.6830	1.6830
Diameter of Nozzle (inches)	0.7493	0.7493	0.7493
Stack Diameter or Equivalent (inches)	20.00	20.00	20.00
Static Pressure (inches H2O)	-0.05	-0.05	-0.05
Barometric Pressure (inches Hg)	30.04	30.04	30.04
Test Time (minutes)	60	60	60
Meter Volume (cubic feet)	40.908	38.195	38.824
Square Root ^P (inches H2O)	0.118	0.117	0.121
Orifice Pressure ^H (inches H2O)	1.417	1.256	1.257
Average Meter Temperature (Deg. F)	67.3	73.9	77.1
Average Stack Temperature (Deg. F)	967.1	1164.9	1153.2
Particulate Sample Weight (grms)	0.0075	0.0124	0.0215
Water Collected (grms)	109.7	122.7	200.2
Percent CO2	6.0	7.0	6.5
Percent O2	12.3	10.8	11.0
Molecular Weight (lbs/lb Mole)	29.45	29.55	29.48
Nozzle Area (square feet)	0.00306	0.00306	0.00306

Attachment A - Field Data

EPA VISIBLE EMISSION OBSERVATION FORM 1

Method Used (Circle One)
 Method 9 203A 203B Other: _____

Company Name Rest Assured Animal Care
 Facility Name _____
 Street Address 2814 Silver Star Road
 City Orlando State FL Zip 32805

Process Animal Care Unit # 1 Operating Mode 77lbs
 Control Equipment Air Purifier Operating Mode 1650°F

Describe Emission Point
Metal Road Stack

Height of Emiss. Pt. Start 19.3' End 19.3' Height of Emiss. Pt. Rel. to Observer Start 19' End 19'
 Distance to Emiss. Pt. Start 60' End 60' Direction to Emiss. Pt. (Degree) Start 260° End 260°

Vertical Angle to Obs. Pt. Start ~15° End _____ Direction to Obs. Pt. (Degree) Start ~60° End 260°
 Distance and Direction to Observation Point from Emission Point Start 144 down End 144 down

Describe Emissions Start NA End NA
 Emission Color Start NA End _____ Water Droplet Plume Attached Detached None

Describe Plume Background Start Sky End Sky
 Background Color Start Blue End Blue Sky Conditions Start Clear End Clear
 Wind Speed Start 2 mph End 3 mph Wind Direction Start NW End NW
 Ambient Temp. Start 52° End 54°F Wet Bulb Temp. _____ RH Percent 86%

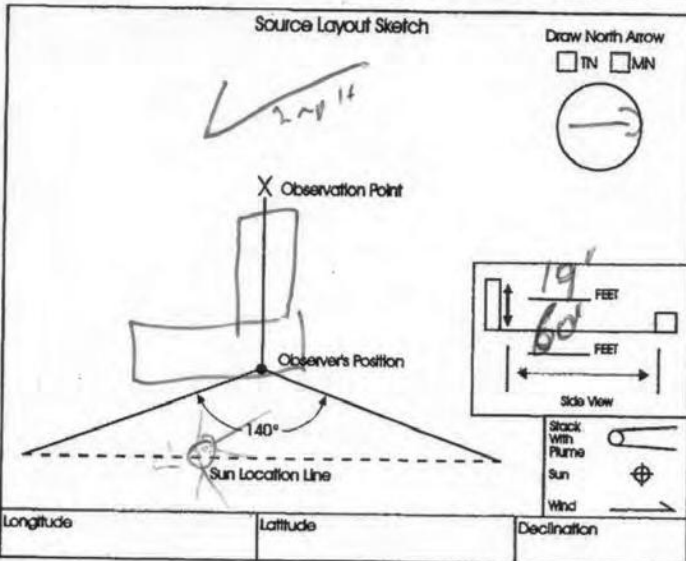

Additional Information _____

Form Number _____ Page 1 of 2
 Continued on VEO Form Number _____

Observation Date		Time Zone				Start Time	End Time
2/2/24						8:30	9:00
Min	Sec	0	15	30	45	Comments	
1	0	0	0	0	0	77 lbs	
2	0	0	0	0	0	Rural	
3	0	0	0	0	0	Sights 900 AKK	
4	0	0	0	0	0	US 75/30 WET II	
5	0	0	0	0	0		
6	0	0	0	0	0		
7	0	0	0	0	0		
8	0	0	0	0	0		
9	0	0	0	0	0		
10	0	0	0	0	0		
11	0	0	0	0	0		
12	0	0	0	0	0		
13	0	0	0	0	0		
14	0	0	0	0	0		
15	0	0	0	0	0		
16	0	0	0	0	0		
17	0	0	0	0	0	1st yr	
18	0	0	0	0	0		
19	0	0	0	0	0		
20	0	0	0	0	0		
21	0	0	0	0	0		
22	0	0	0	0	0		
23	0	0	0	0	0		
24	0	0	0	0	0	No objectionable	
25	0	0	0	0	0	odor were	
26	0	0	0	0	0	detected.	
27	0	0	0	0	0		
28	0	0	0	0	0		
29	0	0	0	0	0		
30	0	0	0	0	0		

Observer's Name (Print) Luis Llorens
 Observer's Signature _____ Date 2/2/24
 Organization AG Environmental
 Certified By DEP/Whitton Date 1/2024

EPA VISIBLE EMISSION OBSERVATION FORM 1

Form Number	Page <u>2</u> of <u>2</u>
Continued on VEO Form Number	

Method Used (Circle One)
 Method 9 203A 203B Other: _____

Company Name Ray Annual Animal creations
 Facility Name Madagascar to: 618 Roundtree Rd.
 Street Address Tested at 2814 Silverthick Rd, #2
 City Charlotte State NC Zip 28217

Process Animal creation Unit # _____ Operating Mode 77h
 Control Equipment Afterburner Operating Mode 1650°F

Describe Emission Point
metal Round stack

Height of Emiss. Pt. Height of Emiss. Pt. Rel. to Observer
 Start 19' End 19' Start 19' End 19'
 Distance to Emiss. Pt. Direction to Emiss. Pt. (Degrees)
 Start 60° End 60° Start 260° End 260°

Vertical Angle to Obs. Pt. Direction to Obs. Pt. (Degrees)
 Start 15° End _____ Start 260° End 260°
 Distance and Direction to Observation Point from Emission Point
 Start 1 FT down End 1 FT down

Describe Emissions
 Start N/A End N/A
 Emission Color Water Droplet Plume
 Start N/A End _____ Attached Detached None

Describe Plume Background
 Start sky End sky
 Background Color Sky Conditions
 Start blue End blue/white Start clear End broken
 Wind Speed Wind Direction
 Start 2 mph End 3 mph Start NW End NW
 Ambient Temp. Wet Bulb Temp. RH Percent
 Start 44°F End 56°F _____ 37%

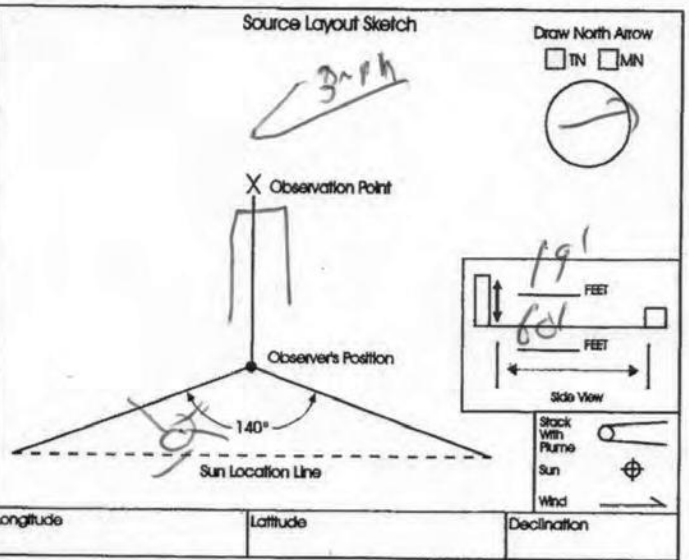

Sec	Time Zone				Start Time	End Time	Comments
	0	15	30	45			
1	0	0	0	0	9:00 AM	9:10 AM	
2	0	0	0	0			
3	0	0	0	0			No observations
4	0	0	0	0			odors were detected.
5	0	0	0	0			
6	0	0	0	0			
7	0	0	0	0			
8	0	0	0	0			
9	0	0	0	0			
10	0	0	0	0			
11	0	0	0	0			
12	0	0	0	0			
13	0	0	0	0			
14	0	0	0	0			
15	0	0	0	0			
16	0	0	0	0			
17	0	0	0	0			
18	0	0	0	0			
19	0	0	0	0			
20	0	0	0	0			
21	0	0	0	0			
22	0	0	0	0			
23	0	0	0	0			
24	0	0	0	0			
25	0	0	0	0			
26	0	0	0	0			
27	0	0	0	0			
28	0	0	0	0			
29	0	0	0	0			
30	0	0	0	0			

Observer's Name (Print) Luis Clarke
 Observer's Signature _____ Date 7/2/24
 Organization AF Environmental
 Certified By DEP/Whitton Date 1/2024



WHITLOW GREEN EPA SMOKE SCHOOL, LLC

WWW.SMOKESCHOOL.NET

CERTIFIES THAT

LUIS LLORENS-U.S. CREMATION EQUIPMENT

Has passed the certification test required by EPA Method 9
40 CFR 60 Appendix A and is qualified as a visible emissions evaluator.

Certification Date: **January 11, 2024** Location: **Orlando, FL**

Jerry Green & Gary Green

OWNERS

FL11124-LL-USCREMATIONEQUIPMENT-03





WHITLOW GREEN EPA SMOKE SCHOOL, LLC

WWW.SMOKESCHOOL.NET

CERTIFIES THAT

LUIS LLORENS-US CREMATION EQUIPMENT

Has attended the visible emissions evaluator course classroom lecture.

Certification Date: **July 14, 2022** Location: **Orlando, FL**

Jerry Green & Gary Green

OWNERS

FI71422-LL-USCREMATIONEQUIPMENT-01





Facility Name: Rest Assured Animal Cremations, LLC
 Unit: Animal Crematory (Model #US 75/300(Gen 2) AKASierra 300)
 Test Location: U.S. Cremation Equipment Manufacturing Facility
 Date: 2/2/2024
 Test No.: 24011-ST
 Run No.: 1
 Start: 8:20
 Stop: 9:20

UNCORRECTED RAW DATA

Date/Time	O2 %	CO PPM
2/2/2024 8:20	14.13	2.25
2/2/2024 8:21	14.20	2.00
2/2/2024 8:22	14.22	1.75
2/2/2024 8:23	14.06	1.75
2/2/2024 8:24	14.68	1.50
2/2/2024 8:25	14.62	1.25
2/2/2024 8:26	14.88	1.00
2/2/2024 8:27	15.88	1.00
2/2/2024 8:28	14.70	0.75
2/2/2024 8:29	14.30	1.00
2/2/2024 8:30	14.52	1.25
2/2/2024 8:31	14.76	1.00
2/2/2024 8:32	13.96	1.00
2/2/2024 8:33	14.06	1.25
2/2/2024 8:34	14.12	1.00
2/2/2024 8:35	14.70	1.00
2/2/2024 8:36	13.25	1.00
2/2/2024 8:37	12.84	1.25
2/2/2024 8:38	12.61	1.00
2/2/2024 8:39	12.68	1.00
2/2/2024 8:40	12.20	1.25
2/2/2024 8:41	12.88	1.00
2/2/2024 8:42	13.77	1.00
2/2/2024 8:43	13.04	1.00
2/2/2024 8:44	12.97	1.00
2/2/2024 8:45	13.41	0.75
2/2/2024 8:46	12.83	0.75
2/2/2024 8:47	13.40	1.25
2/2/2024 8:48	13.58	1.00
2/2/2024 8:49	13.54	4.50
2/2/2024 8:50	12.99	4.50
2/2/2024 8:51	13.27	1.00
2/2/2024 8:52	13.53	0.75
2/2/2024 8:53	11.48	0.75
2/2/2024 8:54	11.05	1.25
2/2/2024 8:55	11.82	1.00
2/2/2024 8:56	9.78	1.25
2/2/2024 8:57	9.58	1.50
2/2/2024 8:58	10.33	1.25
2/2/2024 8:59	9.76	1.00
2/2/2024 9:00	9.73	1.00
2/2/2024 9:01	9.69	1.00
2/2/2024 9:02	10.56	1.00
2/2/2024 9:03	9.85	1.25
2/2/2024 9:04	10.97	1.50
2/2/2024 9:05	11.91	1.25
2/2/2024 9:06	11.22	1.00
2/2/2024 9:07	10.97	1.25
2/2/2024 9:08	11.70	1.00
2/2/2024 9:09	10.45	1.00
2/2/2024 9:10	10.02	1.25
2/2/2024 9:11	9.93	1.25
2/2/2024 9:12	10.55	1.25
2/2/2024 9:13	10.68	1.00
2/2/2024 9:14	10.38	1.00
2/2/2024 9:15	11.09	1.25
2/2/2024 9:16	10.33	1.25
2/2/2024 9:17	10.43	1.25
2/2/2024 9:18	10.66	1.25
2/2/2024 9:19	10.39	1.25
2/2/2024 9:20	10.70	1.00

Uncorrected Average 12.30 1.26
 Bias Corrected Average 12.30 1.23
 Corrected to 7% O2 1.99



Facility Name: Rest Assured Animal Cremations, LLC
 Unit: Animal Crematory (Model #US 75/300(Gen 2) AKASierra 300)
 Facility ID: U.S. Cremation Equipment Manufacturing Facility
 Date: 2/2/2024
 Test No.: 24011-ST
 Run No.: 3
 Start: 11:20
 Stop: 12:20

UNCORRECTED RAW DATA

Date/Time	O2 %	CO PPM
2/2/2024 11:20	11.41	9.00
2/2/2024 11:21	11.39	8.25
2/2/2024 11:22	9.78	9.50
2/2/2024 11:23	9.86	11.75
2/2/2024 11:24	9.94	11.50
2/2/2024 11:25	10.02	10.75
2/2/2024 11:26	10.09	10.00
2/2/2024 11:27	10.07	9.75
2/2/2024 11:28	10.12	9.75
2/2/2024 11:29	10.16	9.50
2/2/2024 11:30	10.16	9.25
2/2/2024 11:31	10.16	8.75
2/2/2024 11:32	10.15	9.00
2/2/2024 11:33	10.16	9.50
2/2/2024 11:34	10.17	9.00
2/2/2024 11:35	10.21	8.75
2/2/2024 11:36	10.15	8.50
2/2/2024 11:37	9.96	8.75
2/2/2024 11:38	10.20	8.25
2/2/2024 11:39	10.27	7.25
2/2/2024 11:40	10.41	6.00
2/2/2024 11:41	10.63	5.25
2/2/2024 11:42	10.76	4.50
2/2/2024 11:43	10.80	4.00
2/2/2024 11:44	10.86	3.75
2/2/2024 11:45	10.90	3.50
2/2/2024 11:46	10.98	3.50
2/2/2024 11:47	11.02	3.50
2/2/2024 11:48	11.08	3.50
2/2/2024 11:49	11.13	3.50
2/2/2024 11:50	11.20	3.25
2/2/2024 11:51	11.27	3.50
2/2/2024 11:52	11.27	3.50
2/2/2024 11:53	11.27	3.75
2/2/2024 11:54	11.30	4.00
2/2/2024 11:55	11.29	3.75
2/2/2024 11:56	11.29	3.75
2/2/2024 11:57	11.35	4.00
2/2/2024 11:58	11.36	3.75
2/2/2024 11:59	11.37	3.75
2/2/2024 12:00	11.49	3.75
2/2/2024 12:01	11.48	3.50
2/2/2024 12:02	11.48	3.50
2/2/2024 12:03	11.48	3.75
2/2/2024 12:04	11.54	3.75
2/2/2024 12:05	11.54	3.50
2/2/2024 12:06	11.59	3.50
2/2/2024 12:07	11.57	3.50
2/2/2024 12:08	11.55	3.50
2/2/2024 12:09	11.61	3.50
2/2/2024 12:10	11.67	3.50
2/2/2024 12:11	11.67	3.50
2/2/2024 12:12	11.69	3.50
2/2/2024 12:13	11.71	3.50
2/2/2024 12:14	11.73	3.50
2/2/2024 12:15	11.77	3.50
2/2/2024 12:16	11.84	3.50
2/2/2024 12:17	11.83	3.50
2/2/2024 12:18	11.86	3.50
2/2/2024 12:19	11.89	3.75
2/2/2024 12:20	11.89	3.50

Uncorrected Average 11.00 5.56
 Bias Corrected Average 10.98 5.45
 Corrected to 7% O2 7.64

ANALYZER CALIBRATION DATA
for
Rest Assured Animal Cremations, LLC

Facility: Rest Assured Animal Cremations, LLC
Project No.: 24011-ST
Date: 2/2/2024
Run Number 1

Unit: Animal Crematory (Model #US 75/300(Gen 2) AKASierra 300)
Personnel: Nicholas Decker
Analyzers: O2, CO
Run Time: 8:20 - 9:20

Analyzer Span	
O2	22.0
CO	380.0

	Calibration Error Check				System Calibration Check				Drift (% of Span)	Calibration Error Factors
	Calibration Value (% or ppm)	Cylinder Number	Analyzer Calibration Response	Difference (% of Span)	Pre Run		Post Run			
					System Response	System Bias (% of Span)	System Response	System Bias (% of Span)		
O ₂ Zero	0.0	EB0137715	0.004	0.02	0.011	0.03	0.023	0.09	0.05	0.02
O ₂ Mid	12.00	EB0058583	11.982	-0.08	11.997	0.07	12.005	0.10	0.04	12.00
O ₂ High	22.0	EB0052408	22.006	0.03	NA		NA			
CO Zero	0.0	EB0137715	0.003	0.00	0.016	0.00	0.034	0.01	0.00	0.03
CO Mid	185.0	223503028	186.200	0.32	186.400	0.05	186.500	0.08	0.03	186.45
CO High	380.0	222303046	380.000	0.00	NA		NA			

Plant: Rest Assured Animal Cremations, LLC
Project No.: 24011-ST
Date: 2/2/2024
Run Number 2

Location: Animal Crematory (Model #US 75/300(Gen 2) AKASierra 300)
Personnel: Nicholas Decker
Analyzers: O2, CO
Run Time: 9:55 - 10:55

Analyzer Span	
O2	22.0
CO	380.0

	Calibration Error Check				System Calibration Check				Drift (% of Span)	Calibration Error Factors
	Calibration Value (% or ppm)	Cylinder Number	Analyzer Calibration Response	Difference (% of Span)	Pre Run		Post Run			
					System Response	System Bias (% of Span)	System Response	System Bias (% of Span)		
O ₂ Zero	0.0	EB0137715	0.004	0.02	0.023	0.09	0.019	0.07	-0.02	0.02
O ₂ Mid	12.00	EB0058583	11.982	-0.08	12.005	0.10	12.014	0.15	0.04	12.01
O ₂ High	22.0	EB0052408	22.006	0.03	NA		NA			
CO Zero	0.0	EB0137715	0.003	0.00	0.034	0.01	0.051	0.01	0.00	0.04
CO Mid	185.0	223503028	186.200	0.32	186.500	0.08	187.000	0.21	0.13	186.75
CO High	380.0	222303046	380.000	0.00	NA		NA			

Plant: Rest Assured Animal Cremations, LLC
Project No.: 24011-ST
Date: 2/2/2024
Run Number 3

Location: Animal Crematory (Model #US 75/300(Gen 2) AKASierra 300)
Personnel: Nicholas Decker
Analyzers: O2, CO
Run Time: 11:20 - 12:20

Analyzer Span	
O2	22.0
CO	380.0

	Calibration Error Check				System Calibration Check				Drift (% of Span)	Calibration Error Factors
	Calibration Value (% or ppm)	Cylinder Number	Analyzer Calibration Response	Difference (% of Span)	Pre Run		Post Run			
					System Response	System Bias (% of Span)	System Response	System Bias (% of Span)		
O ₂ Zero	0.0	EB0137715	0.004	0.02	0.019	0.07	0.022	0.08	0.01	0.02
O ₂ Mid	12.00	EB0058583	11.982	-0.08	12.014	0.15	12.010	0.13	-0.02	12.01
O ₂ High	22.0	EB0052408	22.006	0.03	NA		NA			
CO Zero	0.0	EB0137715	0.003	0.00	0.051	0.01	0.062	0.02	0.00	0.06
CO Mid	185.0	223503028	186.200	0.32	187.000	0.21	186.900	0.18	-0.03	186.95
CO High	380.0	222303046	380.000	0.00	NA		NA			



EPA Method Specific Calculations

Example Calculations From Run 3

8.0 EPA Method 10 CO Calculations

Analyzer Calibration Error:

$$ACE = C_{dir} - C_v / CS \times 100 \quad (\text{Eq. 7E-1})$$

Example Calculation Run 3 (Low)

$$ACE = (0.003 - 0) / 380 \times 100$$

$$ACE = 0.00$$

Example Calculation Run 3 (Mid)

$$ACE = (186.2 - 185) / 380 \times 100$$

$$ACE = 0.32$$

Example Calculation Run 3 (High)

$$ACE = (380 - 380) / 380 \times 100$$

$$ACE = 0.00$$

Analyzer Calibration Error

For a low-, medium-, and high-calibration gas, the difference between the manufacturer certified value and the analyzer response in direct calibration mode, no more than 2.0% of calibration span

System Bias:

$$SB = C_s - C_{dir} / CS \times 100 \quad (\text{Eq. 7E-3})$$

Example Calculation Run 3 (Low (initial))

$$SB = (0.051 - 0.003) / 380 \times 100$$

$$SB = 0.01$$

Example Calculation Run 3 (Low (final))

$$SB = (0.062 - 0.003) / 380 \times 100$$

$$SB = 0.02$$

Example Calculation Run 3 (Mid (initial))

$$SB = (187 - 186.2) / 380 \times 100$$

$$SB = 0.21$$

Example Calculation Run 3 (Mid (Final))

$$SB = (186.9 - 186.2) / 380 \times 100$$

$$SB = 0.18$$

13.2 System Bias

This specification is applicable to both the system bias and 2-point system calibration error tests described in section 8.2.5 and 8.5. The pre- and post-run system bias (or system calibration error) must be within ±5.0 percent of the calibration span for the low-level and upscale calibration gases. Alternatively, the results are acceptable if |Cs-Cdir| is ≤0.5 ppmv or if |Cs-Cv| is ≤0.5 ppmv (as applicable).

Drift Assessment:

$$D = (SB_{Final} - SB_i) / CS \times 100$$

Example Calculation Run 3 (Low)

$$D = (0.062 - 0.051) / 380 \times 100$$

$$D = 0.00$$

Example Calculation Run 3 (Mid)

$$D = (186.9 - 187) / 380 \times 100$$

$$D = -0.03$$

13.3 Drift.

For each run, the low-level and upscale drift must be less than or equal to 3.0 percent of the calibration span. The drift is also acceptable if the pre- and post-run bias (or the pre- and post-run system calibration error) responses do not differ by more than 0.5 ppmv at each gas concentration (i.e. |Cs post-run - Cs pre-run| ≤0.5 ppmv).

Attachment B - Laboratory Data

Particulate Laboratory Data

Rest Assured Animal Cremations, LLC

24011-ST

Run 1

Filter Number	3953	
	Final Weight	0.3717 grams
	Tare Weight	0.3685 grams
	Difference	0.0032 grams
Beaker Number	1D	
	Final Weight	3.0721 grams
	Tare Weight	3.0673 grams
	Difference	0.0048 grams
Filter Blank Number	3956	
	Final Weight	0.3417 grams
	Tare Weight	0.3417 grams
	Difference	0.0000 grams
Acetone Wash Down		
	Volume of Rinse	125 mL
	Residue in Rinse (calculated)	5.06393E-06 mg/mg
	Total Residue in Rinse	0.0005 grams
Total Particulate Weight		0.0075 grams

Water Collected

	Final Impinger Water	301 mL
	Initial Impinger Water	200 mL
	Final Silica Weight	208.9 grams
	Silica Tare Weight	200.0 grams
Total Water Collected		109.7 grams

Analyst Zachary Beatty

Particulate Laboratory Data
Rest Assured Animal Cremations, LLC

24011-ST

Run 2

Filter Number	3954	
	Final Weight	0.3775 grams
	Tare Weight	0.3671 grams
	Difference	0.0104 grams
Beaker Number	2D	
	Final Weight	3.0696 grams
	Tare Weight	3.0671 grams
	Difference	0.0025 grams
Filter Blank Number	3956	
	Final Weight	0.3417 grams
	Tare Weight	0.3417 grams
	Difference	0.0000 grams
Acetone Wash Down		
	Volume of Rinse	125 mL
	Residue in Rinse (calculated)	5.06393E-06 mg/mg
	Total Residue in Rinse	0.0005 grams
Total Particulate Weight		0.0124 grams

Water Collected

	Final Impinger Water	314 mL
	Initial Impinger Water	200 mL
	Final Silica Weight	208.9 grams
	Silica Tare Weight	200.0 grams
Total Water Collected		122.7 grams

Analyst Zachary Beatty

Particulate Laboratory Data
Rest Assured Animal Cremations, LLC

24011-ST

Run 3

Filter Number	3955	
	Final Weight	0.3594 grams
	Tare Weight	0.3426 grams
	Difference	0.0168 grams

Beaker Number	3D	
	Final Weight	3.0411 grams
	Tare Weight	3.0359 grams
	Difference	0.0052 grams

Filter Blank Number	3956	
	Final Weight	0.3417 grams
	Tare Weight	0.3417 grams
	Difference	0.0000 grams

Acetone Wash Down		
	Volume of Rinse	125 mL
	Residue in Rinse (calculated)	5.06393E-06 mg/mg
	Total Residue in Rinse	0.0005 grams

Total Particulate Weight **0.0215 grams**

Water Collected

	Final Impinger Water	391 mL
	Initial Impinger Water	200 mL
	Final Silica Weight	209.5 grams
	Silica Tare Weight	200.0 grams

Total Water Collected **200.2 grams**

Analyst Zachary Beatty

Acetone Blank Calculations



METHOD 5—DETERMINATION OF PARTICULATE MATTER EMISSIONS FROM STATIONARY SOURCES

7.2 Sample Recovery. Acetone, reagent grade, ≤ 0.001 percent residue, in glass bottles, is required. Acetone from metal containers generally has a high residue blank and should not be used. Sometimes, suppliers transfer acetone to glass bottles from metal containers; thus, acetone blanks shall be run prior to field use and only acetone with low blank values (≤ 0.001 percent) shall be used. In no case shall a blank value of greater than 0.001 percent of the weight of acetone used be subtracted from the sample weight.

Constant Variables Used

Density of Acetone: 789.9 mg/ml
 Quantity of Blank: 200ml

Beaker No. 1A
 Initial Weight of Beaker 3.1303
 Final Weight of Beaker 3.1311
 Residue from Blank **0.0008 g**
 Conversion G>MG 0.8 mg

Beaker Final Weight -Beaker Initial Weight
 0.0008 g
 Residue From Blank Multiplied by 1,000
 0.8 mg

Quantity of Blank 200 ml
 Density of Acetone 789.9 mg/ml
 Total mg of Acetone **157980 mg of acetone**

Quantity Of Blank x Density of Acetone
 157980 mg

Total mg of Acetone 157980 mg
 Acetone mg Residue 0.8 mg
 Residue **0.000050639 mg**

Acetone mg Residue/Total mg of Acetone
 0.00050639%
Residue MUST be <.001% **PASS**

Attachment C - Process Data



Beatty Environmental Services, Inc.

Emission Control Device and Process Data Form

Company: US Cremation Equipment

Installation: Crematory

Type of Installation: Sierra 300 A.K.A. US 75/300 Gen II

Type of Material Processed: Pig Remains

Type of Fuel Used: Propane

Type of Pollution Control System: Afterburner

General Condition of Control Equipment: New

Run No.	1	2	3
Start Time	08:20	09:55	11:20
Stop Time	09:23	10:58	12:23
Fuel GPH	propane	propane	propane
Date	2-2-2024	2-2-2024	2-2-2024
Process Rate(LBS)	79	129	130

Signature: Title: President

Printed Name: Luis Llorens Report No. 23011-ST

*By signing above facility designee agrees that all information on this form is true and correct to the best of his/her knowledge.



TO REMOVE PENS:
 PULL PEN UP AT TAB (1)
 AND PUSH OUT (2)



TO INSTALL PENS:

TO CHANGE CHARTS
 PRESS
 DISPLAY=CC
 PRESS
 DISPLAY=CC FLASHES
 PENS GO UPSCALE
 CHANGE THE CHART
 LINE UP START TIME
 WITH START ARROW
 PRESS

START TIME

Beatty Environmental Services Inc.

RETENTION TIME CALCULATION

FACILITY: Rest Assured Animal Cremations, LLC
MODEL: US 75/300(Gen 2) AKA Sierra 300
DATE: 2/2/2024
STACK PRESSURE: -0.05

Run 1	
Stack Flow Rate(ACFM)	1444
Secondary Chamber Volume(cu. Ft.)	42.5
Retention Time	1.77

Run 2	
Stack Flow Rate(ACFM)	1533
Secondary Chamber Volume(cu. Ft.)	42.5
Retention Time	1.66

Run 3	
Stack Flow Rate(ACFM)	1595
Secondary Chamber Volume(cu. Ft.)	42.5
Retention Time	1.60

Average	1.68
----------------	-------------

CALCULATION:

$$\text{Retention Time} = \frac{\text{Secondary Chamber Volume(cu. Ft.)} * 60}{\text{Secondary Chamber Flow (ACFM)}}$$

Attachment D - Calculations For Run 1

CALCULATIONS FOR RUN 1

Rest Assured Animal Cremations, LLC

24011-ST

Page 1 of 2

STACK AREA

$$3.1416 \times (\text{Diameter} / 24)^2$$
$$3.1416 \times (20.00 / 24)^2$$
$$2.18 \quad \text{SQ.FT.}$$

STACK PRESSURE

$$\text{BAROMETRIC PRESSURE} + (\text{STATIC PRESSURE} / 13.6)$$
$$30.04 \quad + \quad (\quad -0.05 \quad / 13.6)$$
$$30.04 \quad \text{IN.HG}$$

METER PRESSURE

$$\text{BAROMETRIC PRESSURE} + (\text{ORIFICE PRESURE} / 13.6)$$
$$30.04 \quad + \quad (\quad 1.42 \quad / 13.6)$$
$$30.14 \quad \text{IN.Hg}$$

SAMPLE VOLUME

$$17.64 \times (\text{Y}) \times \text{METER VOLUME} \times \text{METER PRESSURE} / (\text{METER TEMP.} + 460)$$
$$17.64 \times 0.9998 \times 40.908 \times 30.14 / (67.3 + 460)$$
$$41.247 \quad \text{STD.CU.FT.}$$

WATER VAPOR VOLUME

$$0.04715 \times \text{WATER COLLECTED}$$
$$0.04715 \times 109.7$$
$$5.17 \quad \text{STD.CU.FT.}$$

SAMPLE MOISTURE

$$100 \times \text{WATER VAPOR VOLUME} / (\text{WATER VAPOR VOLUME} + \text{SAMPLE VOLUME})$$
$$100 \times 5.17 / (5.17 + 41.247)$$
$$11.14 \quad \%$$

SATURATION MOISTURE

$$100 \times (\text{VAPOR PRESSURE @ STACK TEMP.} / \text{STACK PRESSURE})$$
$$100 \times (37848.6121 / 30.04)$$
$$100.00 \quad \%$$

STACK MOISTURE FRACTION

$$(\text{THE LESSER OF SAMPLE MOISTURE OR SATURATION MOISTURE}) / 100$$
$$0.111$$

DRY MOLECULAR WEIGHT OF STACK GAS

$$(0.28 \times (100 - \%N_2)) + (0.44 \times \%CO_2) + (0.32 \times \%O_2)$$
$$(0.28 \times (100 - (6.00 + 12.30))) + (0.44 \times 6.00) + (0.32 \times 12.30)$$
$$29.45$$

CALCULATIONS FOR RUN 1
Rest Assured Animal Cremations, LLC

24011-ST

MOLECULAR WEIGHT OF STACK GAS

$$\text{MOLECULAR WEIGHT} \times (1 - \text{MOISTURE}) + (18 \times \text{MOISTURE})$$

$$29.45 \times (1 - 0.111) + (18 \times 0.111)$$

28.18

STACK VELOCITY

$$85.49 \times \text{CP} \times 60 \times \text{SQ.}(\wedge\text{P}) \times \text{SQ.}(\text{STACK TEMP} + 460) / \text{SQ.}(\text{STACK PRESSURE} \times \text{MOLECULAR WT.})$$

$$85.49 \times 0.840 \times 60 \times 0.118 \times \text{SQ.}(967.1 + 460) / \text{SQR}(30.04 \times 28.176)$$

662 FPM

VOLUMETRIC FLOW RATE (ACFM)

STACK AREA X STACK VELOCITY

$$2.18 \times 662$$

1444 ACFM

VOLUMETRIC FLOW RATE (SCFM) DRY

$$17.64 \times (\text{ACFM}) \times \text{STACK PRESSURE} \times (1 - \text{MOISTURE}) / (\text{STACK TEMP.} + 460)$$

$$17.64 \times 1444 \times 30.04 \times (1 - 0.111) / (967.1 + 460)$$

476 SCFM (DRY)

CONCENTRATION (gr/dscf)

Total Particulate Weight X 15.43 / Sample Volume

$$0.0075 \times 15.43 / 41.25$$

0.0028

CONCENTRATION@7% O2 (gr/dscf)

Concentration X 13.9 / (20.9 - %o2)

$$0.0028 \times 13.9 / (20.9 - 12.304)$$

0.0045

MASS EMISSION RATE (LBS./HR.)

CONCENTRATION X (SCFM- DRY) X 60 / 7000

$$0.0028 \times 476 \times 60 / 7000$$

0.01 LBS/HR

PERCENT ISOKINETIC

$$.0945 \times (\text{STACK TEMP.} + 460) \times \text{SAMPLE VOLUME} \times 60$$

$$/ (\text{STACK PRES.} \times \text{VELOCITY} \times \text{NOZZLE AREA} \times \text{TEST TIME} \times (1 - \text{MOISTURE}))$$

$$0.0945 \times (967.08 + 460) \times 41.25 \times 60$$

$$/ (30.04 \times 662 \times 0.00306 \times 60.00 \times (1 - 0.111))$$

102.83 %

Attachment E - Calibration Data

ANNUAL METER CALIBRATION										METER NO. 002047										ORIFICE SET NO. JC40-73									
DATE 6/23/2023					Y= 0.9998					MAX % VARIATION 1.9379%					PASS														
BAROMETRIC PRESSURE 29.91					^Ha= 1.6830					MAX % VARIATION 2.6304%					PASS														
CRITICAL ORIFICE DATA																													
ORIFICE SERIAL NO.	ORIFICE K' FACTOR	ACTUAL VACUUM	^H (IN H2O)	TIME (MIN.)	AMBIENT TEMP INITIAL	AMBIENT TEMP FINAL	METER TEMP INITIAL	METER TEMP FINAL	METER READING INITIAL	METER READING FINAL	VM (CU.FT.)	VM CORRECTED	Vcr STD	Vcr NOMINAL	Y	VARIATION	^H (IN. H2O)	VARIATION											
40	0.2435	25.0	0.30	10	77	76	81	81	880.000	883.207	3.2070	3.1299	3.1443	3.1973	1.0046	-0.0061	1.6652	0.0010											
40	0.2435	24.0	0.30	10	76	76	81	81	883.207	886.388	3.1810	3.1046	3.1458	3.1958	1.0133	0.0026	1.6637	-0.0005											
40	0.2435	24.0	0.30	10	76	76	81	81	886.388	889.566	3.1780	3.1016	3.1458	3.1958	1.0142	0.0035	1.6637	-0.0005											
AVERAGE															1.0107	0.0107	1.6642	0.0112											
48	0.3557	22.5	0.63	10	75	76	81	80	892.000	896.714	4.7140	4.6087	4.5975	4.6662	0.9976	-0.0165	1.6372	-0.0015											
48	0.3557	22.5	0.63	10	76	76	80	80	896.714	901.225	4.5110	4.4143	4.5953	4.6684	1.0410	0.0269	1.6403	0.0015											
48	0.3557	22.5	0.63	10	76	75	80	80	901.225	905.906	4.6810	4.5807	4.5975	4.6662	1.0037	-0.0104	1.6387	0.0000											
AVERAGE															1.0141	0.0141	1.6387	0.0263											
55	0.4616	21.5	1.10	10	76	76	80	79	907.800	913.996	6.1960	6.0759	5.9635	6.0583	0.9815	0.0009	1.7022	-0.0026											
55	0.4616	21.5	1.10	10	76	76	79	78	913.996	920.185	6.1890	6.0803	5.9635	6.0583	0.9808	0.0002	1.7053	0.0005											
55	0.4616	21.5	1.10	10	76	76	78	78	920.185	926.376	6.1910	6.0879	5.9635	6.0583	0.9796	-0.0011	1.7069	0.0021											
AVERAGE															0.9806	0.0194	1.7048	0.0130											
63	0.5916	20.0	1.80	10	76	76	78	78	927.502	935.332	7.8300	7.7128	7.6430	7.7645	0.9909	0.0003	1.7005	0.0000											
63	0.5916	20.0	1.80	10	76	76	78	78	935.332	943.216	7.8840	7.7660	7.6430	7.7645	0.9842	-0.0065	1.7005	0.0000											
63	0.5916	20.0	1.80	10	76	76	78	78	943.216	951.000	7.7840	7.6675	7.6430	7.7645	0.9968	0.0062	1.7005	0.0000											
AVERAGE															0.9906	0.0094	1.7005	0.0104											
73	0.8234	17.0	3.50	10	76	76	78	78	951.500	962.201	10.7010	10.5847	10.6376	10.8067	1.0050	0.0018	1.7069	0.0000											
73	0.8234	17.0	3.50	10	76	76	78	78	962.201	972.924	10.7230	10.6064	10.6376	10.8067	1.0029	-0.0003	1.7069	0.0000											
73	0.8234	17.0	3.50	10	76	76	78	78	972.924	983.661	10.7370	10.6203	10.6376	10.8067	1.0016	-0.0016	1.7069	0.0000											
AVERAGE															1.0032	0.0032	1.7069	0.0142											

SEMI ANNUAL CALIBRATION										DATE 12/19/2023										BAROMETRIC PRESSURE 30.15																													
ORIFICE SERIAL NO.					ORIFICE ACTUAL VACUUM					^H (IN H2O)					TIME (MIN.)					AMBIENT TEMP INITIAL					AMBIENT TEMP FINAL					METER TEMP INITIAL					METER TEMP FINAL					METER READING INITIAL					METER READING FINAL				
55	0.4616	18.0	1.1	10	65	65	61	61	781.700	787.438	5.7380	5.8732	6.0740	5.9958	1.0342	0.0536	1.7127	0.0006																															
55	0.4616	18.0	1.1	10	65	66	61	62	787.438	793.195	5.7570	5.8870	6.0711	5.9987	1.0313	0.0507	1.7127	0.0005																															
55	0.4616	18.0	1.1	10	66	66	62	63	793.195	798.969	5.7740	5.8930	6.0682	6.0015	1.0297	0.0491	1.7110	-0.0011																															
AVERAGE or Max															1.0317	0.045%	1.7121	0.17%																															

METER COMPARISON CHECK (Yqa)										Yqa = (O / Vm) X sqrt(.319 x Tm X 29 / (^Ha x (Pb + (Havg / 13.6) x Md)) X Sqr. ^H avg									
Run 1					Run 2					Run 3					Average				
Yqa = 1.0052					1.0204					1.0073					1.0109				

THERMOCOUPLE CALIBRATION										DATE 6/23/2023										OMEGA HANDHELD CALIBRATION										DATE 4/8/2021									
TC-1 THERMOMETER (DEG F)					ASTM THERMOMETER (DEG F)					TC-1 THERMOMETER (DEG F)					ASTM THERMOMETER (DEG F)																								
ICE 30	212	212	212	212	409	409	409	409	30	30	30	30	32	32	32	32	32	32																					
BOILING H2O 409	212	212	212	212	409	409	409	409	209	209	209	209	212	212	212	212	212	212																					
OIL 409	409	409	409	409	409	409	409	409	405	405	405	405	408	408	408	408	408	408																					

NOZZLE CALIBRATION														
DATE 2/2/2024					AVERAGE									
#20 0.750					0.749					0.7493				

PITOT TUBE CP=84										ACCORDING TO DESIGN SPECIFICATIONS									
------------------	--	--	--	--	--	--	--	--	--	------------------------------------	--	--	--	--	--	--	--	--	--

Beatty Environmental Stack Test Thermocouple Calibrations

Calibration Date : 2/2/2024
Calibration Device: ASTM Thermometer
Calibrated By: Nicholas Decker, Beatty Environmental Services, Inc.



Device	Ambient Air
ASTM Thermometer	67
Dry Gas Meter Thermocouple	67
Filter Thermocouple	66
Filter Heater Thermocouple	67
Impinger Outlet Thermocouple	68
Stack Temp Thermocouple (5ft. Air Cooled)	67

Analyst: 

10.5 Temperature Sensors. Use the procedure in Section 10.3 of Method 2 to calibrate in-stack temperature sensors. Dial thermometers, such as are used for the DGM and condenser outlet, shall be calibrated against mercury-in-glass thermometers. An alternative mercury-free NISTtraceable thermometer may be used if the thermometer is, at a minimum, equivalent in terms of performance or suitably effective for the specific temperature measurement application. As an alternative, the following single-point calibration procedure may be used. After each test run series, check the accuracy (and, hence, the calibration) of each thermocouple system at ambient temperature, or any other temperature, within the range specified by the manufacturer, using a reference thermometer (either ASTM reference thermometer or a thermometer that has been calibrated against an ASTM reference thermometer). The temperatures of the thermocouple and reference thermometers shall agree to within ± 2 °F.



CERTIFICATE OF ANALYSIS

CEM Grade Nitrogen

Customer: Beatty Environmental Services
 CGA: 580
 Customer PO #: 20230016-BESG
 Reference #: 122722WZ-BB
 Certification Date: 01/23/2023
 Expiration Date: 01/23/2031
 Pressure, psig: 2000

Cylinder #: EB0041079 EB0139719
 EB0081276 EB0137715

<u>Component</u>	<u>Certified Concentration</u>
Nitrogen	≥ 99.9995%
O2	< 0.5 ppm
H2O	< 1.0 ppm
THC	< 0.1 ppm
CO2	< 1.0 ppm
CO	< 0.5 ppm
NOx	< 0.1 ppm
SO2	< 0.1 ppm

<u>Instrument/ Model</u>	<u>Serial Number</u>	<u>Last Date Calibrated</u>	<u>Analytical Method</u>
Illinois/ 3000	30-0319	1/2/2023	Electrochemical
Mecco/ Waterboy LP2	14469	1/2/2023	Electrolytic
Gow-Mac/ 23-500	K35606	1/23/2023	Flame Ionization Detector
Micro GC/ Agilent	US020002031	1/23/2023	Thermal Conductivity
Horiba/ VA-5001	M9GW8GMX	1/23/2023	Non-Dispersive Infrared
CAI/ 600	Y09003	1/23/2023	Chemiluminescence
Horiba/ VIA-510	MAID39C8	1/23/2023	Non-Dispersive Infrared

This report states accurately the results of the investigation made upon the material submitted to the analytical laboratory. Every effort has been made to determine objectively the information requested. However, in connection with this report, Global Calibration Gases LLC shall have no liability in excess of the established charge for this service. These materials comply with the requirements for emission testing per 40CFR1065.750.

Produced by:
 Global Calibration Gases LLC.
 1090 Commerce Blvd N.
 Sarasota, Florida 34243 USA
 PGVP Vendor ID.: N22023

Analyst: Signature on file

Approved for release: 01/23/2023



**EPA Protocol
Gas Mixture**

Customer:	Beatty Environmental Services	Reference #:	062123WZ-10
CGA:	590	Certification Date:	06/29/2023
Customer PO #:	BES2300214	Expiration Date:	06/29/2031
Cylinder #:	EB0058583	Pressure, psig:	2000

Method: This standard was analyzed according to EPA Traceability Protocol for Assay and Certification of Gaseous Calibration Standards, Procedure G1 (May 2012).

Components	Requested Concentration	Certified Concentration	Expanded Uncertainty (rel)	Assay Dates
Carbon Dioxide	9%	9.00%	0.8%	06/29/23
Oxygen	12%	12.00%	0.7%	06/29/23
Nitrogen	Balance	Balance	-	-

Reference Standard	Cylinder #	Concentration	Expanded Uncertainty (rel)	Expiration Date
Carbon Dioxide/ GMIS	CC105858	11.99%	0.5%	10/20/28
Carbon Dioxide/ SRM	CAL016053	15.63%	0.2%	02/07/25
Oxygen/ GMIS	EB0047724	12.53%	0.5%	11/08/27
Oxygen/ SRM	CAL015787	20.72%	0.2%	08/23/21

Instrument/ Model	Serial Number	Last Date Calibrated	Analytical Method
Micro GC/ Inficon	70094393	6/29/2023	Thermal Conductivity
Teledyne 3000MA	345133	6/29/2023	Paramagnetic

This mixture was prepared gravimetrically using a high load high sensitivity electronic scale. Prior to filling the scale is verified for accuracy throughout the target mass range against applicable NIST traceable weights, calibrated to ASTM E617-97 Echelon 1 tolerances.

This report states accurately the results of the investigation made upon the material submitted to the analytical laboratory. Every effort has been made to determine objectively the information requested. However, in connection with this report, there shall be no liability in excess of the established charge for this service.

The calibration results published in this certificate were obtained using equipment and standards capable of producing results that are traceable to National Institute of Standards and Technology (NIST). The expanded uncertainties use a coverage factor of k=2 to approximate the 95% confidence level of the measurement. This calibration certificate applies only to the item described and shall not be reproduced other than in full, without written approval from the calibration facility. These materials comply with the requirements for emission testing per 40CFR1065.750. Do not use this standard when cylinder pressure is below 100 psig.

Produced and assayed by:
Global Calibration Gases LLC
1090 Commerce Blvd N.
Sarasota, Florida 34243
PGVP Vendor ID: N22023

Analyst: Signature on file

Approved for release: 06/29/2023

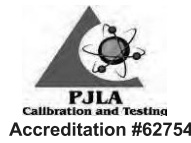

Red Ball Technical Gas Service
 555 Craig Kennedy Way
 Shreveport, LA 71107
 800-551-8150
 PGVP Vendor ID # G12021

EPA PROTOCOL GAS CERTIFICATE OF ANALYSIS

Cylinder Number:	EB0052408	Certification Date:	12/22/2021
Product ID Number:	130047	Expiration Date:	12/20/2029
Cylinder Pressure:	1900 PSIG	MFG Facility:	- Shreveport - LA
COA #	EB0052408.20211214-0	Lot Number:	EB0052408.20211214
Customer PO. NO.:		Tracking Number:	074202283
Customer:		Previous Certification Dates:	

This calibration standard has been certified per the May 2012 EPA Traceability Protocol, Document EPA-600/R-12/531, using procedure G1.

Do Not Use This Cylinder Below 100 psig (0.7 Megapascal).

Certified Concentration(s)

Component	Concentration	Uncertainty	Analytical Principle	Assayed On
Carbon Dioxide	16.60 %	±0.05 %	NDIR	12/22/2021
Oxygen	22.0 %	±0.12 %	MPA	12/21/2021
Nitrogen	Balance			

Analytical Measurement Data Available Online.

Reference Standard(s)

Serial Number	Lot	Expiration	Type	Balance	Component	Concentration	Uncertainty(%)	NIST Reference
EB0022021	EB0022021.20180323	07/15/2026	GMIS	N2	CO2	14.9 %	0.777	101001
EB0039149	EB0039149.20190610	11/24/2027	GMIS	N2	CO2	24.75 %	0.274	C1579010.02
EB0087693	EB0087693.20180504	07/21/2026	GMIS	N2	O2	24 %	0.497	071001

Analytical Instrumentation

Component	Principle	Make	Model	Serial	MPC Date
O2	MPA	Thermo	410i	1162980025	11/22/2021
CO2	NDIR	Thermo	410i	1162980025	12/20/2021

SMART-CERT

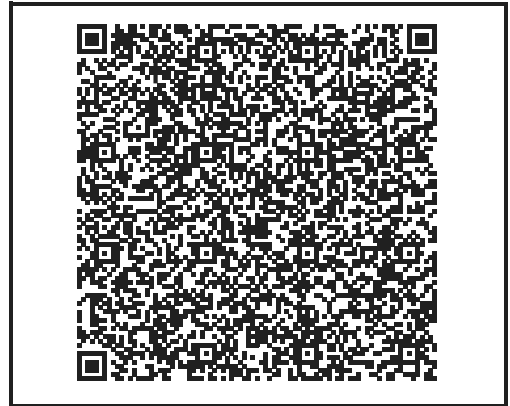

This is to certify the gases referenced have been calibrated/tested, and verified to meet the defined specifications. This calibration/test was performed using Gases or Scales that are traceable through National Institute of Standards and Technology (NIST) to the International System of Units (SI). The basis of compliance stated is a comparison of the measurement parameters to the specified or required calibration/testing process. The expanded uncertainties use a coverage factor of k=2 to approximate the 95% confidence level of the measurement, unless otherwise noted. This calibration certificate applies only to the item described and shall not be reproduced other than in full, without written approval from Red Ball Technical Gas Services. If not included, the uncertainty of calibrations are available upon request and were taken into account when determining pass or fail.

Anthony Cyr
 Assistant Operations Manager
 Assay Laboratory: Red Ball TGS
 Version 02-J, Revised on 2018-09-17



EPA Protocol Gas Mixture

Customer:	Beatty Environmental Services	Reference #:	012323WZ-9
CGA:	660	Certification Date:	02/08/2023
Customer PO #:	20230016-BESG	Expiration Date:	02/08/2031
Cylinder #:	223503028	Pressure, psig:	2000

Method: This standard was analyzed according to EPA Traceability Protocol for Assay and Certification of Gaseous Calibration Standards, Procedure G1 (May 2012).

Components	Requested Concentration	Certified Concentration	Expanded Uncertainty (rel)	Assay Dates
Nitric Oxide	185ppm	186.4ppm	1.0%	02/01/23, 02/08/23
NOx	185ppm	188.0ppm	1.0%	02/01/23, 02/08/23
Carbon Monoxide	185ppm	185ppm	1.1%	02/01/23
Nitrogen	Balance	Balance	-	-

Reference Standard	Cylinder #	Concentration	Expanded Uncertainty	Expiration Date
Nitric Oxide/ GMIS	EB0055162	195.6ppm	0.8%	10/30/23
NOx/ GMIS	EB0055162	196.5ppm	0.8%	10/30/23
Nitric Oxide/ SRM	CAL017400	244.5ppm	0.5%	11/02/15
NOx/ SRM	CAL017400	244.7ppm	0.5%	11/02/15
Carbon Monoxide/ GMIS	GN0000161	251.0ppm	0.5%	11/27/27
Carbon Monoxide/ SRM	FF30742	247.1 ppm	0.2%	04/13/24

Instrument/ Model	Serial Number	Last Date Calibrated	Analytical Method
CAI/ 600 Horiba/ VA-5001	Y09003 M9GW8GMX	2/8/2023 2/1/2023	Chemiluminescence Non-Dispersive Infrared

This mixture was prepared gravimetrically using a high load high sensitivity electronic scale. Prior to filling the scale is verified for accuracy throughout the target mass range against applicable NIST traceable weights, calibrated to ASTM E617-97 Echelon 1 tolerances.

This report states accurately the results of the investigation made upon the material submitted to the analytical laboratory. Every effort has been made to determine objectively the information requested. However, in connection with this report, there shall be no liability in excess of the established charge for this service.

The calibration results published in this certificate were obtained using equipment and standards capable of producing results that are traceable to National Institute of Standards and Technology (NIST). The expanded uncertainties use a coverage factor of k=2 to approximate the 95% confidence level of the measurement. This calibration certificate applies only to the item described and shall not be reproduced other than in full, without written approval from the calibration facility. These materials comply with the requirements for emission testing per 40CFR1065.750. Do not use this standard when cylinder pressure is below 100 psig.

Produced and assayed by:
Global Calibration Gases LLC
1090 Commerce Blvd N
Sarasota, Florida 34243
PGVP Vendor ID.: N22023

Analyst: Signature on file

Approved for release: 02/08/2023



EPA Protocol Gas Mixture

Customer:	Beatty Environmental Services	Reference #:	012323WZ-8
CGA:	660	Certification Date:	02/08/2023
Customer PO #:	20230016-BESG	Expiration Date:	02/08/2031
Cylinder #:	222303046	Pressure, psig:	2000

Method: This standard was analyzed according to EPA Traceability Protocol for Assay and Certification of Gaseous Calibration Standards, Procedure G1 (May 2012).

Components	Requested Concentration	Certified Concentration	Expanded Uncertainty (rel)	Assay Dates
Nitric Oxide	375ppm	366.3ppm	0.8%	02/01/23, 02/08/23
NOx	375ppm	369.2ppm	0.8%	02/01/23, 02/08/23
Carbon Monoxide	375ppm	380ppm	0.8%	02/01/23
Nitrogen	Balance	Balance	-	-

Reference Standard	Cylinder #	Concentration	Expanded Uncertainty	Expiration Date
Nitric Oxide/ GMIS	GN0000305	393.0ppm	0.6%	09/14/26
NOx/ GMIS	GN0000305	393.7ppm	0.6%	09/14/26
Nitric Oxide/ SRM	CAL015880	782.4ppm	0.4%	01/09/19
NOx/ SRM	CAL015880	785.7ppm	0.4%	01/09/19
Carbon Monoxide/ GMIS	GN0000161	251.0ppm	0.5%	11/27/27
Carbon Monoxide/ SRM	FF30742	247.1 ppm	0.2%	04/13/24

Instrument/ Model	Serial Number	Last Date Calibrated	Analytical Method
CAI/ 600 Horiba/ VA-5001	Y09003 M9GW8GMX	2/8/2023 2/1/2023	Chemiluminescence Non-Dispersive Infrared

This mixture was prepared gravimetrically using a high load high sensitivity electronic scale. Prior to filling the scale is verified for accuracy throughout the target mass range against applicable NIST traceable weights, calibrated to ASTM E617-97 Echelon 1 tolerances.

This report states accurately the results of the investigation made upon the material submitted to the analytical laboratory. Every effort has been made to determine objectively the information requested. However, in connection with this report, there shall be no liability in excess of the established charge for this service.

The calibration results published in this certificate were obtained using equipment and standards capable of producing results that are traceable to National Institute of Standards and Technology (NIST). The expanded uncertainties use a coverage factor of $k=2$ to approximate the 95% confidence level of the measurement. This calibration certificate applies only to the item described and shall not be reproduced other than in full, without written approval from the calibration facility. These materials comply with the requirements for emission testing per 40CFR1065.750. Do not use this standard when cylinder pressure is below 100 psig.

Produced and assayed by:
Global Calibration Gases LLC
1090 Commerce Blvd N
Sarasota, Florida 34243
PGVP Vendor ID.: N22023

Analyst: Signature on file

Approved for release: 02/08/2023

Nozzle Calibration

Nozzle ID #20

A = 0.750

B = 0.749

C = 0.749

Average 0.7493

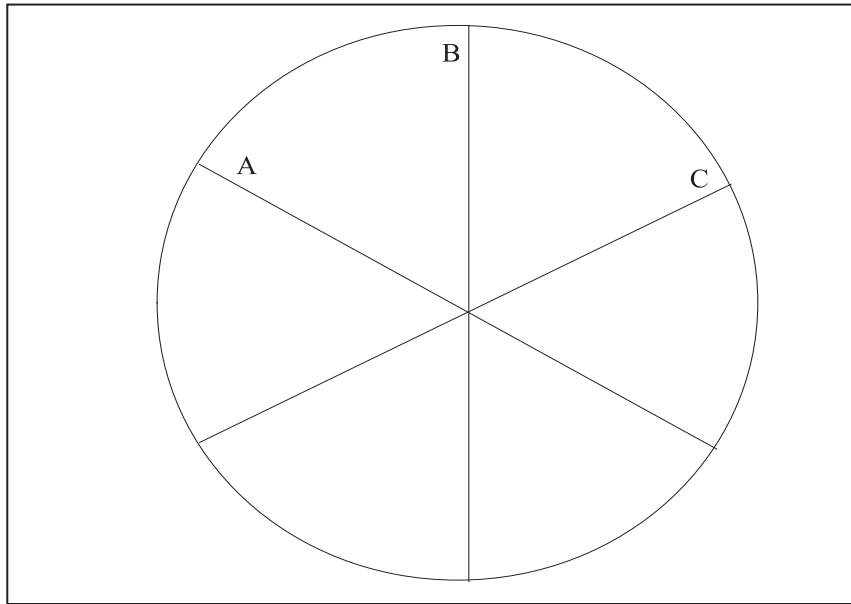

Calibration Date 2/2/2024

Calibrated by

A handwritten signature in black ink, appearing to be 'JD' or similar, is written over the 'Calibrated by' label.

PITOT CALIBRATION

(Type S Pitot Tube Inspection)

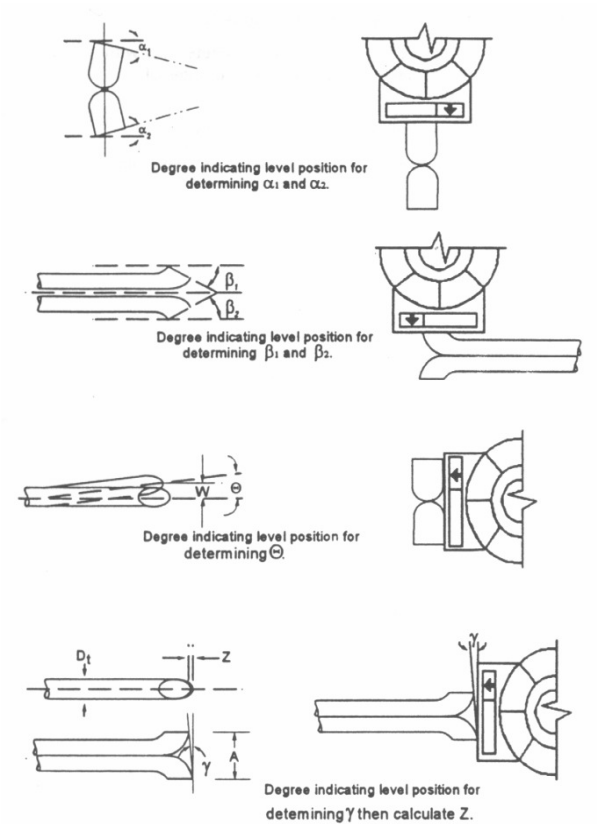

Level and Perpendicular?	Yes
Obstruction?	No
Damaged?	No
α_1 ($-10^\circ \leq \alpha_1 \leq +10^\circ$)	2
α_2 ($-10^\circ \leq \alpha_2 \leq +10^\circ$)	3
β_1 ($-5^\circ \leq \beta_1 \leq +5^\circ$)	1
β_2 ($-5^\circ \leq \beta_2 \leq +5^\circ$)	2
γ	1
θ	1
$z = A \tan \gamma$ ($\leq 0.125^\circ$)	0.017
$w = A \tan \theta$ ($\leq 0.03125^\circ$)	0.017
D_t ($3/16'' \leq D_t \leq +3/8''$)	0.375
A	0.984
$A/2 D_t$ ($1.05 \leq P_A / D_t \leq 1.51$)	1.312

Certification

I hereby certify that type S pitot tube ID# P-5AC meets or exceeds all specifications, criteria and applicable design features, and is hereby assigned a pitot tube calibration factor of 0.84.

Certified by:

Date

6/23/2023

Attachment F - Project Participants

Project Participants

Beatty Environmental Services, Inc.

Daniel R. Beatty
Project Director

Nicholas Decker
Field Manager(Method 5 Console, Method 3A/10)

Jeffery Rutledge
Field Technician I(Probe Technician)

Zachary Beatty
Director of Operations

US Cremation Equipment

Luis Llorens
President / EPA Method 9 Observer

Texas Commission on Environmental Quality

Standard Permit New Registration

Site Information (Regulated Entity)

What is the name of the site to be authorized?	Wilbarger Humane Society
Does the site have a physical address?	Yes
Physical Address	
Number and Street	2805 SULLIVAN ST
City	VERNON
State	TX
ZIP	76384
County	WILBARGER
Latitude (N) (##.#####)	34.162977
Longitude (W) (-###.#####)	-99.298388
Primary SIC Code	7261
Secondary SIC Code	
Primary NAICS Code	812210
Secondary NAICS Code	
Regulated Entity Site Information	
What is the Regulated Entity's Number (RN)?	
What is the name of the Regulated Entity (RE)?	Wilbarger Humane Society
Does the RE site have a physical address?	Yes
Physical Address	
Number and Street	2805 SULLIVAN ST
City	VERNON
State	TX
ZIP	76384
County	WILBARGER
Latitude (N) (##.#####)	34.16297
Longitude (W) (-###.#####)	-99.29803
Facility NAICS Code	812210
What is the primary business of this entity?	Humane Society adding cremation services

Customer (Applicant) Information

How is this applicant associated with this site?	Owner Operator
What is the applicant's Customer Number (CN)?	
Type of Customer	Organization
Full legal name of the applicant:	
Legal Name	Wilbarger Humane Society
Texas SOS Filing Number	
Federal Tax ID	751563665
State Franchise Tax ID	
State Sales Tax ID	
Local Tax ID	
DUNS Number	

Number of Employees

Independently Owned and Operated?

I certify that the full legal name of the entity applying for this permit has been provided and is legally authorized to do business in Texas.

Yes

Responsible Authority Contact

Organization Name

Wilbarger Humane Society

Prefix

MR

First

Robert

Middle

Last

Webb

Suffix

Credentials

Title

Owner

Responsible Authority Mailing Address

Enter new address or copy one from list:

RE Physical Address

Address Type

Domestic

Mailing Address (include Suite or Bldg. here, if applicable)

2805 SULLIVAN ST

Routing (such as Mail Code, Dept., or Attn:)

City

VERNON

State

TX

ZIP

76384

Phone (###-###-####)

9408395825

Extension

Alternate Phone (###-###-####)

Fax (###-###-####)

E-mail

fluidpusher8246@att.net

Responsible Official Contact

Person TCEQ should contact for questions about this application:

Same as another contact?

Wilbarger Humane Society

Organization Name

Wilbarger Humane Society

Prefix

MR

First

Robert

Middle

Last

Webb

Suffix

Credentials

Title

Owner

Enter new address or copy one from list:

Mailing Address

Address Type

Domestic

Mailing Address (include Suite or Bldg. here, if applicable)

2805 SULLIVAN ST

Routing (such as Mail Code, Dept., or Attn:)

City

VERNON

State

TX

ZIP

76384

Phone (###-###-####)

9408395825

Extension

Alternate Phone (###-###-####)

Fax (###-###-####)

E-mail

fluidpusher8246@att.net

Technical Contact

Person TCEQ should contact for questions about this application:

Same as another contact?

Wilbarger Humane Society

Organization Name

Wilbarger Humane Society

Prefix

MR

First

Robert

Middle

Last

Webb

Suffix

Credentials

Title

Owner

Enter new address or copy one from list:

Mailing Address

Address Type

Domestic

Mailing Address (include Suite or Bldg. here, if applicable)

2805 SULLIVAN ST

Routing (such as Mail Code, Dept., or Attn:)

City

VERNON

State

TX

ZIP

76384

Phone (###-###-####)

9408395825

Extension

Alternate Phone (###-###-####)

Fax (###-###-####)

E-mail

fluidpusher8246@att.net

Standard Permit General Information- New Reg Sites

1) Is this facility permanent or temporary?

Permanent

2) Will the proposed facility meet all of the requirements of the standard permit?

Yes

3) Select the type of unit that is being registered:

ANIMAL CARCASS INCINERATORS

3.1) Select the rule associated to the unit specified.

6009

3.2) Is the facility equal to or greater than 50 ft. from the nearest property line?

Yes

Standard Permit Attachments

Please attach one PDF with the PI-1S and all required documents to complete the project.

[File Properties]

File Name

10370 PI-1S WILBARGER HS.docx

Hash

5147E49C58BBC24802817A97B94D8F2454A573946A45439560B94E8161027485

MIME-Type

application/vnd.openxmlformats-officedocument.wordprocessingml.document

Confidential

No

[File Properties]

File Name CORE_DATA WILBARGERHS 041326.docx
Hash 95B4F104AD2D66B529D9C23AF5A6EAF26FA726AD524B0CFBAB4AE27E42BAEB9B
MIME-Type application/vnd.openxmlformats-officedocument.wordprocessingml.document
Confidential No

[File Properties]

File Name Application Covers WilbargerHS.pdf
Hash B2F92BFC37CFE9677671D60A877B22514424E37E563F459195BCA86A64C338B5
MIME-Type application/pdf
Confidential No

Please attach any other necessary information needed to complete the registration.

[File Properties]

File Name 75 300 Gen II Flyer SIERRA 300.pdf
Hash 0F6BADEF84E29189EF747F4E5109AAFF1FBA97A50120C3AF2071E20F777B3DC
MIME-Type application/pdf
Confidential No

[File Properties]

File Name 2024-02-02 US Cremations Equipment-
Manufacturing Facility 24011-ST.pdf
Hash DDB23D505876D5F50D72FFAAA93758C512E6DC57DA88A05754E1429673A44B99
MIME-Type application/pdf
Confidential No

[File Properties]

File Name Google Earth.pdf
Hash 8A4944D2820D3A4F0112FAB589F6A506A02C864C22F327515C3DF7A3C4846BF2
MIME-Type application/pdf
Confidential No

[File Properties]

File Name Google Maps.pdf
Hash 09B80D62892602D67C6BC05F4D1B589F5C5DC44BC0EF2B8EA59B7A86EC783437
MIME-Type application/pdf
Confidential No

[File Properties]

File Name Emissions 060724.pdf
Hash 78DC7AF2BFD1E016C2909F1F532716C9B21663D08487C0AC9D2A441903589A44
MIME-Type application/pdf
Confidential No

[File Properties]

File Name Process Flow Diagram animal.pdf
Hash BA5418BC97D14EC374479E63A129F0C94AC31B9A49AEDD4A78D6FEEAFC0FCB6E
MIME-Type application/pdf
Confidential No

[File Properties]

File Name	US 75300 Animal Specs gen2 030426.pdf
Hash	1F270A66E0BDDF67F5017EE314855D708E013397192E05960391A3939D3310C2
MIME-Type	application/pdf
Confidential	No

[File Properties]

File Name	USCE-75300-S300-ELEV-ASSY.pdf
Hash	075FA52BE31E48FF14B8E2F75B8CD446C018E141F41A684F1342C65FF986B79D
MIME-Type	application/pdf
Confidential	No

Expedite

Per Texas Health and Safety Code, Section 382.05155, does the applicant want to expedite the processing of this application? No

Certification

The electronic signature below indicates that the Responsible Official has knowledge of the facts herein set forth and that the same are true, accurate, and complete to the best of my knowledge and belief. By this signature, the maximum emission rates listed on this certification reflect the maximum anticipated emissions due to the operation of this facility and all representations in this certification of emissions are conditions upon which the facilities and sources will operate. It is understood that it is unlawful to vary from these representations unless the certification is first revised. The signature certifies that to the best of the Responsible Officials knowledge and belief, the project will satisfy the conditions and limitations of the indicated exemption or permit by rule and the facility will operated in compliance with all regulations of the Texas Commission on Environmental Quality and with Federal U.S. Environmental Protection Agency regulations governing air pollution. The signature below certifies that, based on information and belief formed after reasonable inquiry, the statements and information above and contained in the attached document(s) are true, accurate, and complete. If you questions on how to fill out this form or about air quality permits. Please call (512) 239-1250. Individuals are entitled to request and review their personal information that the agency gathers on its forms.

1. I am Robert M Webb III, the owner of the STEERS account ER122596.
2. I have the authority to sign this data on behalf of the applicant named above.
3. I have personally examined the foregoing and am familiar with its content and the content of any attachments, and based upon my personal knowledge and/or inquiry of any individual responsible for information contained herein, that this information is true, accurate, and complete.
4. I further certify that I have not violated any term in my TCEQ STEERS participation agreement and that I have no reason to believe that the confidentiality or use of my password has been compromised at any time.
5. I understand that use of my password constitutes an electronic signature legally equivalent to my written signature.
6. I also understand that the attestations of fact contained herein pertain to the implementation, oversight and enforcement of a state and/or federal environmental program and must be true and complete to the best of my knowledge.
7. I am aware that criminal penalties may be imposed for statements or omissions that I know or have reason to believe are untrue or misleading.
8. I am knowingly and intentionally signing Standard Permit New Registration.
9. My signature indicates that I am in agreement with the information on this form, and authorize its submittal to the TCEQ.

OWNER OPERATOR Signature: Robert M Webb III OWNER OPERATOR

Customer Number:

Legal Name: Wilbarger Humane Society

Account Number: ER122596

Signature IP Address: 104.156.1.58

Signature Date: 2026-05-11

Signature Hash: 5CCA5860AC11D1D51500F881C977A14958012A94D1F627E44AA3BF37F58EB098

Form Hash Code at time of Signature: E3A0C16B564BBED407EFB70F1816C6869A38296FD62DF9D4B0B5C1D5967D927B

Fee Payment

Transaction by:	The application fee payment transaction was made by ER122596/Robert M Webb III
Paid by:	The application fee was paid by ROBERT WEBB III
Fee Amount:	\$900.00
Paid Date:	The application fee was paid on 2026-05-11
Transaction/Voucher number:	The transaction number is 582EA000734015 and the voucher number is 830623

Submission

Reference Number:	The application reference number is 916114
Submitted by:	The application was submitted by ER122596/Robert M Webb III
Submitted Timestamp:	The application was submitted on 2026-05-11 at 14:29:43 CDT
Submitted From:	The application was submitted from IP address 104.156.1.58
Confirmation Number:	The confirmation number is 768601
Steers Version:	The STEERS version is 6.94

Additional Information

Application Creator: This account was created by Luis Llorens



TCEQ Use Only

TCEQ Core Data Form

For detailed instructions regarding completion of this form, please read the Core Data Form Instructions or call 512-239-5175.

SECTION I: General Information

1. Reason for Submission (If other is checked please describe in space provided.)		
<input checked="" type="checkbox"/> New Permit, Registration or Authorization (Core Data Form should be submitted with the program application.)		
<input type="checkbox"/> Renewal (Core Data Form should be submitted with the renewal form)	<input type="checkbox"/> Other	
2. Customer Reference Number (if issued)	Follow this link to search for CN or RN numbers in Central Registry**	3. Regulated Entity Reference Number (if issued)
CN		RN

SECTION II: Customer Information

4. General Customer Information	5. Effective Date for Customer Information Updates (mm/dd/yyyy)	4/13/2026	
<input checked="" type="checkbox"/> New Customer <input type="checkbox"/> Update to Customer Information <input type="checkbox"/> Change in Regulated Entity Ownership <input type="checkbox"/> Change in Legal Name (Verifiable with the Texas Secretary of State or Texas Comptroller of Public Accounts)			
The Customer Name submitted here may be updated automatically based on what is current and active with the Texas Secretary of State (SOS) or Texas Comptroller of Public Accounts (CPA).			
6. Customer Legal Name (If an individual, print last name first: eg: Doe, John)		If new Customer, enter previous Customer below:	
Wilbarger Humane Society			
7. TX SOS/CPA Filing Number	8. TX State Tax ID (11 digits)	9. Federal Tax ID (9 digits)	10. DUNS Number (if applicable)
		75-1563665	
11. Type of Customer:	<input checked="" type="checkbox"/> Corporation	<input type="checkbox"/> Individual	Partnership: <input type="checkbox"/> General <input type="checkbox"/> Limited
Government: <input type="checkbox"/> City <input type="checkbox"/> County <input type="checkbox"/> Federal <input type="checkbox"/> State <input type="checkbox"/> Other	<input type="checkbox"/> Sole Proprietorship	<input type="checkbox"/> Other:	
12. Number of Employees		13. Independently Owned and Operated?	
<input checked="" type="checkbox"/> 0-20 <input type="checkbox"/> 21-100 <input type="checkbox"/> 101-250 <input type="checkbox"/> 251-500 <input type="checkbox"/> 501 and higher		<input checked="" type="checkbox"/> Yes <input type="checkbox"/> No	
14. Customer Role (Proposed or Actual) – as it relates to the Regulated Entity listed on this form. Please check one of the following			
<input checked="" type="checkbox"/> Owner <input type="checkbox"/> Operator <input type="checkbox"/> Owner & Operator <input type="checkbox"/> Occupational Licensee <input type="checkbox"/> Responsible Party <input type="checkbox"/> Voluntary Cleanup Applicant <input type="checkbox"/> Other:			
15. Mailing Address:	2805 Sullivan Street		
	City	Vernon	State TX ZIP 76384 ZIP + 4
16. Country Mailing Information (if outside USA)		17. E-Mail Address (if applicable)	
		fluidpusher8246@att.net	
18. Telephone Number	19. Extension or Code	20. Fax Number (if applicable)	
(940) 839-5825		() -	

SECTION III: Regulated Entity Information

21. General Regulated Entity Information (If 'New Regulated Entity' is selected below this form should be accompanied by a permit application)
<input checked="" type="checkbox"/> New Regulated Entity <input type="checkbox"/> Update to Regulated Entity Name <input type="checkbox"/> Update to Regulated Entity Information
The Regulated Entity Name submitted may be updated in order to meet TCEQ Agency Data Standards (removal of organizational endings such as Inc, LP, or LLC).
22. Regulated Entity Name (Enter name of the site where the regulated action is taking place.)
Wilbarger Humane Society

23. Street Address of the Regulated Entity: <i>(No PO Boxes)</i>	2805 Sullivan Street						
	City	Vernon	State	TX	ZIP	76384	ZIP + 4
24. County	Hidalgo						

Enter Physical Location Description if no street address is provided.

25. Description to Physical Location:	See Item 23					
26. Nearest City	State			Nearest ZIP Code		
	TX					
27. Latitude (N) In Decimal:	34.1629777778		28. Longitude (W) In Decimal:	-99.2980388889		
Degrees	Minutes	Seconds	Degrees	Minutes	Seconds	
34	9	46.72	99	17	52.94	
29. Primary SIC Code (4 digits)	30. Secondary SIC Code (4 digits)	31. Primary NAICS Code (5 or 6 digits)	32. Secondary NAICS Code (5 or 6 digits)			
	0751		812220			
33. What is the Primary Business of this entity? <i>(Do not repeat the SIC or NAICS description.)</i>						
Animal Cremation						
34. Mailing Address:	2801 Sullivan Street					
	City	Vernon	State	TX	ZIP 76384 ZIP + 4	
35. E-Mail Address:	fluidpusher8246@att.net					
36. Telephone Number	37. Extension or Code	38. Fax Number <i>(if applicable)</i>				
() -		() -				

39. TCEQ Programs and ID Numbers Check all Programs and write in the permits/registration numbers that will be affected by the updates submitted on this form. See the Core Data Form instructions for additional guidance.

<input type="checkbox"/> Dam Safety	<input type="checkbox"/> Districts	<input type="checkbox"/> Edwards Aquifer	<input type="checkbox"/> Emissions Inventory Air	<input type="checkbox"/> Industrial Hazardous Waste
<input type="checkbox"/> Municipal Solid Waste	<input checked="" type="checkbox"/> New Source Review Air	<input type="checkbox"/> OSSF	<input type="checkbox"/> Petroleum Storage Tank	<input type="checkbox"/> PWS
<input type="checkbox"/> Sludge	<input type="checkbox"/> Storm Water	<input type="checkbox"/> Title V Air	<input type="checkbox"/> Tires	<input type="checkbox"/> Used Oil
<input type="checkbox"/> Voluntary Cleanup	<input type="checkbox"/> Waste Water	<input type="checkbox"/> Wastewater Agriculture	<input type="checkbox"/> Water Rights	<input type="checkbox"/> Other:

SECTION IV: Preparer Information

40. Name:	Luis Llorens	41. Title:	President
42. Telephone Number	43. Ext./Code	44. Fax Number	45. E-Mail Address
(407) 923-3945		(321) 282-7358	ai@cfL.rr.com

SECTION V: Authorized Signature

46. By my signature below, I certify, to the best of my knowledge, that the information provided in this form is true and complete, and that I have signature authority to submit this form on behalf of the entity specified in Section II, Field 6 and/or as required for the updates to the ID numbers identified in field 39.

Company:	Wilbarger Humane Society	Job Title:	Owner/President
Name <i>(In Print)</i> :	Robert Webb	Phone:	(940) 839- 5825
Signature:		Date:	

**Texas Commission on Environmental Quality
Registrations for Air Standard Permit
Form PI-1S Instructions**

Table of Contents

Introduction	1
Overview.....	1
Small Business Information and Agency Contacts.....	1
Instructions for Form PI-1S.....	2
I. Registrant Information	2
II. Facility and Site Information.....	2
III. Fee Information	5
IV. Public Notice	5
V. Renewal Certification Option.....	6
VI. Technical Information Including State and Federal Regulatory Requirements.....	7
VII. Delinquent Fees and Penalties	10
VIII. Signature Requirements	10
IX. Copies of the Registration.....	10

Introduction

The primary purpose of the Form PI-1S is to provide all administrative and technical information needed by the Air Permit Division (APD) to evaluate Standard Permit applications. These instructions are intended for use by applicants and consultants to help you prepare a complete Standard Permit request. The review of your project will go faster if you provide all necessary documents and information requested in the Form PI-1S and in the Core Data Form (TCEQ No. 10400).

Note: Applicants submitting registrations for Concrete Batch Plants (6004) and Concrete Batch Plants with Enhanced Controls (6008) must submit the PI-1S-CBP available here: https://www.tceq.texas.gov/permitting/air/forms/newsourcereview/nsr_sp_forms.html. It is required for these standard permit registrations received on or after September 1, 2020.

Applicants submitting registrations for the Marine Loading Operations standard permit (6021) are required to submit the PI-1S-MLO available here: https://www.tceq.texas.gov/permitting/air/forms/newsourcereview/nsr_sp_forms.html.

Overview

Texas Commission on Environmental Quality (TCEQ) regulates the release of air contaminants for specific, well-characterized classes of facilities under its Standard Permits.

Standard Permit projects must meet the requirements of the specific Standard Permit. For more information about the available Standard Permits, see our web page Standard Air Permits at www.tceq.texas.gov/permitting/air/nav/standard.html. The TCEQ also has an Air Quality Permitting fact sheet available to assist you in determining some of the other state or federal requirements you may need to know at <https://www.tceq.texas.gov/assets/public/permitting/air/factsheets/permit-factsheet.pdf>.

ePermits: The TCEQ now requires the use of the online TCEQ e-Services system at www.tceq.texas.gov/e-services to register your standard permit, pay registration fees, and receive registrations. To use the online system, you need to have an active State of Texas Environmental Electronic Reporting System (STEERS) account. Access STEERS at www3.tceq.texas.gov/steers/. For help with ePermits refer to the TCEQ STEERS ePermits Help web page at www3.tceq.texas.gov/steers/help/epr/eprmain.html. If an attachment cannot be submitted through STEERS due to the file size of an attachment which exceeds 50 MB or a file type which is not accepted, submit through FTPS. If using FTPS, you will share files with APIRT@tceq.texas.gov for the initial submittal. Once your project has been assigned, you will share files directly with your reviewer.

Confidential files should be submitted through STEERS or the TCEQ FTPS. All pages must be marked confidential and have *confidential* in the file name. Confidential submittals must be separate from non-confidential submittals.

Small Business Information and Agency Contacts

For agency contacts, see Contact Information for Air Permit Applications (including Environmental Assistance Division) at www.tceq.texas.gov/assets/public/permitting/air/airapp-contacts.pdf.

Instructions for Form PI-1S

These instructions are provided to assist the regulated community to accurately complete a registration request to operate under a standard permit.

I. Registrant Information

- A. Company or Other Legal Customer Name:** Registrations are claimed by either the facility owner or operator, commonly referred to as the “registrant.” List the legal name of the company, corporation, partnership, or person who is applying for the standard permit. Applicants can verify the legal name with the Texas Secretary of State at (512) 463-5555 or at www.sos.state.tx.us. The TCEQ will also verify the legal name with the Texas Secretary of State. You may be asked to correct the name provided on the Form PI-1S, if found to be different. In some cases, we may request a copy of the legal document forming the entity to verify the legal name; for example: general partnership filed with the county.
- B. Company Official Contact Information:** Provide the name, title, mailing address, telephone number, fax number, and email address of the company official contact. The company official must not be a consultant. All correspondence and issued permit documents will be sent via email within one business day of TCEQ’s decision. Please ensure that the email address provided for the company official is the most appropriate to receive time-sensitive correspondence from the TCEQ.
- C. Technical Contact Information:** Provide the name, title, company, mailing address, telephone number, fax number, and email address of the person TCEQ should contact for technical questions. This person must have the authority to make binding agreements and representations on behalf of the registrant. The technical contact may be a consultant.

II. Facility and Site Information

- A. Name and Type of Facility:** Enter the name of the facility for which the standard permit registration is being requested. The name should be descriptive and indicate the general type of operation, manufacturing process, equipment, or facility which would be authorized under the standard permit (include any numerical designation, if appropriate). The name must be descriptive and specific. Examples of acceptable names are, “Sulfuric Acid Plant” and “No. 5 Steam Boiler” Vague names such as, “Chemical Plant” and “North Process Area,” are not acceptable names. Also, check the appropriate box indicating the type of facility as either permanent or temporary. For hot mix asphalt plants, a temporary plant is limited to 180 days on site, or for the duration required to complete a single project. Hot mix asphalt plants that are expected to remain on site more than 180 days, and all rock and concrete crushers are considered permanent. Additionally, oil and gas production units are usually considered to be permanent. For portable units, please provide the serial number(s) of the equipment being authorized.
- B. Facility Location Information:** Provide the street address of the facility, if available. If there is no street address, describe the physical location with specific written directions. Identify the location by distance and direction from well-known landmarks, such as highway intersections. It is very important to also include the city and county where the facility will be located. If the address is not located in a city, then enter the city or town closest to the facility even if it is not in the same county as the facility. The county indicated must be the county where the facility is physically located. Please include the ZIP Code of the physical facility site, not the ZIP Code of the applicant’s mailing address. In some cases, the TCEQ may request a map showing the location of the facility during the review of the standard permit registration.

Enter the latitude and longitude coordinates in degrees, minutes, and nearest second (DDD:MM:SS) or in decimal form for the street address or the destination point of the driving directions. Latitude indicates the angular distance of a location north of the equator and will always be between 25 and 37 degrees north (N) in Texas. Longitude indicates the angular distance of a location west of the prime meridian and will always be between 93 and 107 degrees

west (W) in Texas. For help obtaining the latitude and longitude, you may view USGS maps, county maps prepared by the Texas Department of Transportation, or an online software application such as Google Earth.

C. TCEQ Core Data Form: We require that you submit a Core Data Form (TCEQ Form Number 10400) on all incoming applications unless the following are met.

1. Regulated Entity and Customer Reference Numbers have been issued by the TCEQ and;
2. No Core data information has changed.

Note: The Core Data Form is required for Standard Permits 6006, 6007, and 6013, without exception. Information required on the Core Data Form includes the following:

- Customer Reference Number (CN): This is a unique number given to each business, governmental body, association, individual, or other entity that owns, operates, is responsible for, or is affiliated with a regulated entity. We assign the CN when a Core Data Form is initially submitted.
- Regulated Entity Number (RN): This is a unique agency assigned number given to each person, organization, place, or thing that is of environmental interest to us and where regulated activities will occur. The RN is assigned when a Core Data Form is initially submitted, if the agency has conducted an investigation, or if the agency has issued an enforcement action. The RN replaces existing air account numbers. The RN for portable units is assigned to the unit itself, and that same RN should be used when applying for authorization at a different location.

Note: *The company and facility site information provided on the Core Data Form must be the same as provided on the Form PI-1S.*

D. TCEQ Account Identification Number: This number was assigned by the TCEQ to the entire property owned or controlled by the applicant at a specific location. A typical example of an air quality account number is, JB-1234-R. Portable facilities are assigned account identification numbers which begin with a number, such as 92-1234-K. Provide your TCEQ account identification number if known.

E. Type of Action: Indicate the type of action being requested by checking the appropriate box. Check:

- *Initial Application* – if the facility has not previously been authorized by a standard permit,
- *Change to Registration* – if the facility has been previously registered, but changes or additions have occurred,
- *Renewal or Renewal Certification* – if a standard permit registration for the facility must be renewed. To determine which type of renewal the project qualifies for, see Section V Renewal Certification Option.

Provide the existing registration number and expiration date if Change to Registration, Renewal, or Renewal Certification is checked.

- F. Standard Permit Claimed:** Provide the standard permit that is being claimed. Below is a list of standard permits that can be claimed using the PI-1S. If the standard permit to be claimed is not listed, please check the Air Permits website for the appropriate registration or notification form at www.tceq.texas.gov/permitting/air/nav/standard.html.

Standard Permit	Description
6001	Pollution Control Projects
6002	Oil and Gas Facilities
6005	Electric Generating Unit
6007	Permanent Hot Mix Asphalt Plants Temporary Hot Mix Asphalt Plants
6009	Animal Carcass Incinerator
6011	Boilers
6012	Sawmills
6013	Permanent Rock and Concrete Crushers
6014	Anhydrous Ammonia Storage and Distribution Operations
6015	Dry Bulk Fertilizer Handling Operations
6016	Cotton Gin Facilities and Cotton Burr Tub Grinders
6017	Feedmills, Portable Augers, and Hay Grinders
6018	Grain Elevator/Grain Handling Operations and Portable Grain Augers
6019	Peanut-Handling Operations
6020	Temporary and Permanent Polyphosphate Blenders

- G. Previous Standard Exemption or PBR Registration Number:** If this standard permit application is for a change to an existing facility previously authorized under a standard exemption or PBR, list the previous standard exemption number(s), PBR registration number(s), and the associated effective date. Also attach additional information on whether the facility still meets the previous standard exemption or PBR, or whether a new registration is required and the previous standard exemption or PBR should be voided.
- H. Other Facilities at this Site Authorized by Standard Exemption, PBR, or Standard Permit:** To properly track how this standard permit application may relate to other authorizations or compliance with TCEQ standard permit regulations, it is important to list all standard exemption number(s), PBR registration number(s), and Standard Permit registration number(s), and the associated effective date.
- I. Other Air Preconstruction Permits:** If the registration is for a site that has any other minor or federal NSR air preconstruction permits, list all permit numbers.
- J. Affected Air Preconstruction Permits:** If the standard permit being claimed directly affects any permitted facility, list the affected preconstruction permit numbers.

K. Federal Operating Permit (FOP) Requirements (30 TAC Chapter 122 Applicability):

Information and guidance on applicability of 30 TAC Chapter 122 can be accessed on our Program Applicability web page at www.tceq.texas.gov/permitting/air/titlev/pro_applicability.html.

1. If this standard permit application results in an increase in the site's potential to emit and renders the site a major source as defined in 30 TAC 122, a FOP application is required. Check the appropriate box if you are submitting a GOP or SOP application or revision application. Guidance on submitting these applications is available on the Guidance for Title V Operating Permits web page at www.tceq.texas.gov/permitting/air/nav/air_titlevopperm.html.
2. Identify the type(s) of FOP(s) issued for the site by checking the appropriate box. In addition, check the appropriate box if any General Operating Permit (GOP) or Site Operating Permit (SOP) application(s) for the site, including revision applications, are currently under review.

If you have questions about the applicability of 30 TAC Chapter 122 or impact of this Form PI-S on your existing FOP, please contact the TCEQ APD at (512) 239-1250, and ask to speak with someone in the Operating Permits Section.

III. Fee Information

Most standard permit registrations require an application fee at the time of application submittal. All fees must be paid prior to processing any standard permit authorization. All fees must be paid through STEERS.

- A. Fee Amount:** Review the specific standard permit you are requesting authorization for on our Standard Air Permits web page at www.tceq.texas.gov/permitting/air/nav/standard.html to determine fee requirements. Enter the fee amount paid for this registration.
- B. Payment Information:** Enter voucher number from ePay, if available.

IV. Public Notice

The THSC 382.056 and corresponding rules in 30 TAC Chapter 39 (Public Notice), or the Standard Permit being claimed, may require that you publish a notice of application, or a consolidated Notice of Application and Intent to Obtain Permit and Notice of Application and Preliminary Decision. Notices must be published in a newspaper of general circulation in the municipality where the proposed facility is or will be located. The notice must include a description of the facility and the fact that a person who may be affected by emissions from the facility may submit comments about the project, request a public hearing – as applicable to the Standard Permit being claimed, or request any other information the TCEQ requires by rule. Signs must also be posted around the proposed facility location – as applicable to the Standard Permit being claimed. Additional information regarding public notice such as an overview of requirements, an applicability table, and a list of some common errors that may cause re-notice and delays in processing your application can be found at www.tceq.texas.gov/permitting/air/bilingual/how1_2_pn.html.

Review the specific standard permit you are requesting authorization for on our Standard Air Permits web page at www.tceq.texas.gov/permitting/air/nav/standard.html to determine public notice requirements.

If you are unsure whether public notice applies, we encourage you to complete this section to expedite review of your application.

- A. Responsible Person:** A designated representative for the applicant should be identified as the person responsible for ensuring public notice is properly published in the appropriate newspaper and signs as applicable are posted at the facility site. Provide the name, title, company, mailing address, telephone number, fax number, and email address of the responsible person. This person will be contacted directly when the TCEQ is ready to authorize public notice for the application. To expedite contact, email and fax numbers are requested.

- B. Technical Contact:** The THSC 382.056 requires that each public notice contain a technical contact to represent the applicant during the public comment period. Provide the name, title, company, mailing address, telephone number, fax number, and email address of the technical contact. This person is responsible for answering any questions from the general public regarding the application and their name and phone number will be listed in the public notice. This person may or may not be the technical contact for the permit application review.
- C. Bilingual Notice:** In some cases, 30 TAC 39.405(h) or the Standard Permit being claimed requires that you publish public notice in an alternative language newspaper. The questions on the Form PI-1S are designed to assist you in determining if a bilingual notice is required. If an elementary or middle school nearest to the facility is in a school district required by the Texas Education Code to have a bilingual program, a bilingual notice will be required. If there is no bilingual program required in the school nearest the facility, but children who would normally attend those schools are eligible to attend bilingual programs elsewhere in the school district, the bilingual notice will also be required. If it is determined that alternate language notice is required, you are responsible for ensuring that the publication in the alternate language is complete and accurate in that language.
- D. Small Business Classification and Alternate Public Notice:** If a permit is being requested by a small business, the rules allow for alternative public notification requirements if all of the following are met:
- the company employs 100 people or less, or the company generates 6 million dollars or less in gross annual receipts;
 - the source is not a major stationary source under the federal operating permit requirements;
 - the site does not emit 50 tons per year or more of any individual regulated air contaminant; and
 - the site does not emit 75 tons per year or more of all regulated air contaminants combined.

If these requirements are met, public notice does not have to include publication of the prominent (15 square inch) newspaper notice.

V. Renewal Certification Option

Renewal projects qualify for the renewal certification option if the answer is, “No,” to each of the following questions in this section. The application for renewal certification projects does not need to include the Technical Information in Section VI. Except for renewals of a registration for the Standard Permit for Pollution Control Projects or Electric Generating Units, if a new version of the applicable standard permit has been issued since the applicant’s last action, the renewal certification option is not available.

Note: If notice is applicable and comments are received in response to the public notice, the application does not qualify for the renewal certification option.

- A.** Does the permitted facility emit an air contaminant on the Air Pollutant Watch List and is the permitted facility located in an area on the watch list? The air contaminants and locations can be found on the TCEQ website at www.tceq.texas.gov/toxicology/apwl/apwl.html.
- B.** For facilities participating in the Houston/Galveston/Brazoria area (HGB) cap and trade program for highly reactive VOCs (HRVOCs), the HRVOCs need to be speciated on the maximum allowable emission rates table (MAERT). For information on the HGB area cap and trade program for HRVOCs refer to 30 TAC §115.10. If this permit authorized emission of ethylene, propylene, 1, 3-butadiene, or butenes, these emissions must be speciated on the MAERT.
- C.** Does the company and/or site have an unsatisfactory compliance history? The compliance history rating for the company and the site can be found on the TCEQ website at <https://www2.tceq.texas.gov/oce/ch/index.cfm> by entering the regulated entity number or customer name.

- D. Are there any applications currently under review for this standard permit registration?
- E. Are planned maintenance, startup, or shutdown emissions required to be included in the standard permit registration at this time?
- F. Are any of the following actions being requested at this time? For more information regarding changes to representations refer to 30 TAC §116.615.
 - Are there any facilities that have been permanently shutdown that are proposed to be removed from the standard permit registration?
 - The following can result in changes to the standard permit registration:
 - Changes to representations at the site
 - Emissions factors changes for any source
 - Emissions calculation methodology changes for any source
 A newer version of Compilation of Air Pollutant Emission Factors (AP-42) has been adopted with new emission factors (AP-42 can be found at www.epa.gov/air-emissions-factors-and-quantification/ap-42-compilation-air-emission-factors)
 As a result, do changes need to be made to the standard permit registration in order to remain in compliance?
 - Are sources or facilities that have always been present and represented, but never identified in the standard permit registration, proposed to be included with this renewal?
 - Are there any changes to the current emission rates table being proposed?

VI. Technical Information Including State and Federal Regulatory Requirements

If any of the technical information below is not included with this submittal, it may result in a deficiency and voiding of the project. Additionally, any essential information (lab analysis, NAAQS compliance demonstrations, etc.) that is needed to confirm that facilities are meeting the requirements of the standard permit, must also be included. Attachments should include detailed demonstrations of compliance with all requirements.

A. Standard Permit Requirements: you must demonstrate compliance with the following, or provided detailed information for why any requirement is not applicable:

- General requirements in 30 TAC Sections 116.610 and 116.615,
- Emission limitations¹ of 30 TAC 106.261 or 30 TAC 106.262, and
- Individual requirements of the specific standard permit.

To assist you with preparing technical information, review our Air Quality Standard Permits General Requirements Checklist (TCEQ Form 20335) available on our Forms Search web page at www.tceq.texas.gov/search_forms.html. Use of the checklist is optional; however, your review will go faster if you supply this checklist.

B. Confidential Information: THSC Section 382.041 requires us not to disclose any information related to manufacturing processes that is marked Confidential. Mark any information related to secret or proprietary processes or methods of manufacture as “Confidential,” if you do not want this information in the public file. All confidential information should be separated from the standard permit application and submitted as a separate file within the same submittal. Additional information regarding confidential information can be found at www.tceq.texas.gov/permitting/air/confidential.html.

¹ Unless specified by a particular standard permit, any project which results in a net increase of emissions of air contaminants from the project other than carbon dioxide, water, nitrogen, methane, ethane, hydrogen, oxygen, or those for which a National Ambient Air Quality Standard (NAAQS) has been established must meet the emission limitations of 30 TAC 106.261 or 30 TAC 106.262.

- C. Process Flow Diagram:** Provide a process flow diagram so that the permit reviewer can verify all technical information regarding the affected facility. The process flow diagram should be sufficiently descriptive so the permit reviewer can determine the raw materials to be used in the process; all major processing steps and major equipment items; individual emission points associated with each process step; the location and identification of all emission abatement devices; and the location and identification of all waste streams (including wastewater streams that may have associated air emissions). Block flow diagrams generally are not sufficient except for very simple facilities such as boilers.

Alternate material flows and changes in routing of emissions during periods of planned MSS should be depicted as well as any alternate emission control devices that will be used during these periods.

- D. Process Description:** Provide a process description to accompany the process flow diagram that discusses each step in the process and provides a step-by-step explanation of exactly how your business operates. The description should lead the permit reviewer through the process with emphasis on where the emissions are generated, why the emissions must be generated, what air pollution controls are used (including process design features that minimize emissions), and where the emissions enter the atmosphere.

The process description must also explain how the facility or facilities will be operating when the maximum possible emissions are produced. For some source types, this will probably be the highest production rate. For other source types, the maximum emission rates may occur at partial load. When applicable, discuss cycle times, reaction times, temperatures, pressures, material flow rates, and production rates. Be specific, and do not use generalities such as a small amount, sometimes, and occasionally opened. The process description must also include how the facility is operated during periods of planned MSS and what emission reduction techniques will be used to limit emissions, changes in character of emissions, and the frequency and duration of each type of planned MSS activity.

All information in the process description is an enforceable representation.

- E. Maximum Emissions Data and Calculations:** Represent the maximum hourly and total annual emission rates of the project, including emission rates for planned MSS facilities and related activities. You must also provide a demonstration of expected continuous compliance with the represented emission rates.

Note: submittal of a Table 1(a) for standard permits is not required; however, your review will go faster if you supply the Table 1(a), which is available at www.tceq.texas.gov/assets/public/permitting/air/Forms/NewSourceReview/Tables/10153tbl.pdf.

The permit reviewer must be able to duplicate all emission calculations to verify and confirm emissions data and rates represented in the application. Supporting calculations and the technical bases for the emission rates are required. Include all emission rates calculations and any assumptions made in determining the emission rates.

List and discuss planned MSS activities separately. Provide emission rates and supporting emissions information from planned MSS activities, frequency, and duration of all planned MSS activities, and all planned MSS activity effects on emission rates. Additionally, note all emission points unique to MSS activities. Maximum hourly emission rates, in pounds per hour, from planned MSS should be based on the maximum rates expected from the MSS activities. Annual planned MSS emission rates, in tons per year, should be based on the number of expected MSS activities during any consecutive 12-month period.

Maximum hourly emission rates, in pounds per hour, should be based on the maximum (design) production capacity of the facility. Dividing the annual emissions in tons per year by the annual hours of operation in order to determine hourly emissions in pounds per hour is often unacceptable and inaccurate since this approach typically underestimates hourly emissions.

Maximum annual emission rates, in tons per year, should reflect the operation of the facility throughout any consecutive 12-month period with consideration given to future facility growth.

Include a discussion of the hours of operation and how the hours of operation relate to emission rates on an hourly and annual basis.

If the process is a non-continuous batch operation, or there are widely varying operating scenarios, clearly identify and account for the variations in emissions in the maximum hourly and annual emission rates. Supply additional information to describe the emission variations, particularly for emissions from MSS facilities and related activities.

Include emission rate information for each air contaminant during production operations and during periods of planned MSS. Contaminants must be specifically identified. For example: methanol rather than hydrocarbons or polter/styrene resin dust and iron dust rather than dust. Provide applicable Material Safety Data Sheets (MSDS), Safety Data Sheets (SDS), Air Quality Data Sheets, or equivalent supporting documents that provide complete speciation for all mixtures that contain potential air contaminants.

If spreadsheets are used to estimate emissions, they should be formatted such that they are clear and easy to follow and include example calculations with units and the data sources for the inputs. The permit reviewer may request an electronic version of the spreadsheet to verify the emission calculations are correct.

- F. Plot Plan:** Provide a plot plan that clearly shows a scale, a north arrow, all property lines, emission points, buildings, tanks, process vessels, other process equipment, and two benchmark locations (preferably UTM coordinates). If you submit the plot plan electronically, the preferred format to use is *.dxf or *.dwg or any other computer aided drawing (CAD) format. Labeling on the plot plan listing identification of emission points, buildings, tanks, etc., must be consistent with other representations in the permit application such as emission calculations, process flow diagrams, Table 1(a), air dispersion modeling (if any), other permitting representations, and the TCEQ Emissions Inventory, if required.

Note: All emission points on the affected property must be identified, including emission points approved in other air authorizations (e.g., NSR permits, Standard Permits, PBRs, Standard Exemptions, and Title V Operating Permits). Please provide a table of all emission points that identifies the authorization type and authorization identifier, such as a permit number or rule citation under which each emission point is currently authorized.

- G. Projected Start of Construction Date, Projected Start of Operation Date, and Length of Time at the Site:** Provide the projected start of construction date, projected start of operation date, and the length of time the facility has been located at the site.

Note: Construction is broadly interpreted as anything other than site clearance or site preparation. Activities such as land clearing, soil load-bearing tests, leveling of the area, sewers and utility lines, road building, power line installation, fencing, and construction shack building are considered site clearance or preparation. Equipment may be received at a plant site and stored, provided no attempt is made to assemble the equipment or connect it to any electrical, plumbing, or other utility system. All work, such as excavation, form erection, or foundations upon which facilities will rest is considered construction. Submit any questions regarding the definition of start of construction to airperm@tceq.texas.gov with copies to the appropriate TCEQ regional office and any local air pollution control program(s) having jurisdiction. Each request for clarification must be in writing with sufficient detail to identify the specific activity in question, and the agency response to this request must be in writing for the authorization to be valid. Additional information can be found at www.tceq.texas.gov/permitting/air/newsourcereview/before.html.

VII. Delinquent Fees and Penalties

We will not process your application until all delinquent fees and applicable penalties owed to the TCEQ or the Office of the Attorney General on behalf of the TCEQ are paid in accordance with the Delinquent Fee and Penalty Protocol. More information regarding delinquent fee and penalties can be found at

www.tceq.texas.gov/agency/financial/fees/delin/index.html<https://www.tceq.texas.gov/agency/delin/index.html>.

VIII. Signature Requirements

The Company Official identified in Section I.B. must sign all copies of the application. The applicant's consultant cannot sign the application. If this project has a capital cost of more than \$2,000,000.00, this application must be submitted under seal of a Registered Texas Professional Engineer (P.E.) or the appropriate exemption must be claimed pursuant to the Texas Engineering Practice Act.

The Company Official's signature confirms knowledge of the facts included in the application, and affirms the facts contained in the application are true and correct. The signature also signifies awareness that intentionally or knowingly making false statements or representations in the application is a criminal offense subject to criminal penalties.

Note: Signatures must be original and in ink. Signatures may not be reproduced by photocopy, fax, or other means. The original signature must be received before any permit is issued.

Applicants may check application receipt and status using the New Source Review Air Permits web page at www2.tceq.texas.gov/airperm/index.cfm?fuseaction=airpermits.start. For questions relating to the initial receipt and administrative review of the application, please contact the Air Permits Initial Review Team at (512) 239-1250.

IX. Copies of the Registration

The PI-1S application must be submitted through ePermits. No additional copies need to be sent to the Regional Office or local Air Pollution Control Program(s). The link to ePermits can be found here: <https://www3.tceq.texas.gov/steers/>.

A copy must also be maintained on-site. For sites that normally operate unattended, a copy must be maintained at an office within Texas that has operational control of the site.

Also, all *subsequent* correspondence should be copied to the TCEQ regional office and local air pollution control program(s), as appropriate. Do not attach a copy of Form PI-1S to subsequent correspondence unless specifically requested, as this may cause another registration file to be created. Indicate the assigned TCEQ registration number, TCEQ regulated entity number, and permit reviewer, if known, on all subsequent correspondence.

Texas Commission on Environmental Quality
Form PI-1S
Registrations for Air Standard Permit
(Page 1)

I. Registrant Information		
A. Company or Other Legal Customer Name: Wilbarger Humane Society		
B. Company Official Contact Information (<input type="checkbox"/> Mr. <input checked="" type="checkbox"/> Mrs. <input type="checkbox"/> Ms. <input type="checkbox"/> Other:)		
Name: Robert Webb		
Title: Owner		
Mailing Address: 2805 Sullivan Street		
City: Vernon	State: TX	ZIP Code: 76384
Phone: 940-839-5825	Fax:	
Email Address: fluidpisher8246@att.net		
<i>All permit correspondence will be sent via email.</i>		
C. Technical Contact Information (<input checked="" type="checkbox"/> Mr. <input type="checkbox"/> Mrs. <input type="checkbox"/> Ms. <input type="checkbox"/> Other:)		
Name: Luis Llorens		
Title: President/Project Manager		
Company Name: AI Environmental Consulting Services, Inc./U.S. Cremation Equipment		
Mailing Address: 2814 Silver Star Road, Suite 201-D		
City: Orlando	State: FL	ZIP Code: 32808
Phone: 407-923-3945	Fax: 321-282-7358	
Email Address: ai@cfL.rr.com		
II. Facility and Site Information		
A. Name and Type of Facility – Animal Cremation facility		
Facility Name: Wilbarger Humane Society		
Type of Facility:	<input checked="" type="checkbox"/> Permanent <input type="checkbox"/> Temporary	
For portable units, please provide the serial number of the equipment being authorized below.		
Serial No: NA	Serial No: NA	

**Texas Commission on Environmental Quality
Form PI-1S
Registrations for Air Standard Permit
(Page 2)**

II. Facility and Site Information (continued)		
B. Facility Location Information		
Street Address: 2805 Sullivan Street		
If there is no street address, provide written driving directions to the site and provide the closest city or town, county, and ZIP code for the site (attach description if additional space is needed).		
City: Vernon	County: Wilbarger	ZIP Code: 76384
Latitude (nearest second): 34.1629777778 N	Longitude (nearest second): -99.2980388889 W	
C. Core Data Form (required for Standard Permits 6006, 6007, and 6013).		
Is the Core Data Form (TCEQ Form 10400) attached?		<input checked="" type="checkbox"/> Yes <input type="checkbox"/> No
If "No," provide customer reference number (CN) and regulated entity number (RN) below.		
Customer Reference Number (CN):		
Regulated Entity Number (RN):		
D. TCEQ Account Identification Number (if known):		
E. Type of Action:		
<input checked="" type="checkbox"/> Initial Application <input checked="" type="checkbox"/> Change to Registration <input type="checkbox"/> Renewal <input type="checkbox"/> Renewal Certification		
For Change to Registration, Renewal, or Renewal Certification actions provide the following:		
Registration Number:	Expiration Date:	
F. Standard Permit Claimed: 6009		
G. Previous Standard Exemption or PBR Registration Number:		
Is this authorization for a change to an existing facility previously authorized under a standard exemption or PBR?		<input type="checkbox"/> Yes <input checked="" type="checkbox"/> No
If "Yes," enter previous standard exemption number(s) and PBR registration number(s) and associated effective date in the spaces provided below.		
Standard Exemption and PBR Registration Number(s)	Effective Date	

**Texas Commission on Environmental Quality
Form PI-1S
Registrations for Air Standard Permit
(Page 3)**

II. Facility and Site Information (continued)	
H. Other Facilities at this Site Authorized by Standard Exemption, PBR, or Standard Permit	
Are there any other facilities at this site that are authorized by an Air Standard Exemption, PBR, or Standard Permit?	<input type="checkbox"/> Yes <input checked="" type="checkbox"/> No
If "Yes," enter standard exemption number(s), PBR registration number(s), and Standard Permit registration number(s), and associated effective date in the spaces provided below.	
Standard Exemption, PBR Registration, and Standard Permit Registration Number(s)	Effective Date
I. Other Air Preconstruction Permits	
Are there any other air preconstruction permits at this site?	<input type="checkbox"/> Yes <input type="checkbox"/> No
If "Yes," enter permit number(s) in the spaces provided below.	
J. Affected Air Preconstruction Permits	
Does the standard permit directly affect any permitted facility?	<input type="checkbox"/> Yes <input type="checkbox"/> No
If "Yes," enter permit number(s) in the spaces provided below.	

**Texas Commission on Environmental Quality
Form PI-1S
Registrations for Air Standard Permit
(Page 4)**

II. Facility and Site Information (continued)		
K. Federal Operating Permit (FOP) Requirements		
Is this facility located at a site that is required to obtain a FOP pursuant to 30 TAC Chapter 122?	<input type="checkbox"/> Yes <input checked="" type="checkbox"/> No <input type="checkbox"/> To Be Determined	
If the site currently has an existing FOP, enter the permit number:		
Check the requirements of 30 TAC Chapter 122 that will be triggered if this standard permit is approved (<i>check all that apply</i>).		
<input type="checkbox"/> Initial Application for a FOP <input type="checkbox"/> Significant Revision for a SOP <input type="checkbox"/> Minor Revision for a SOP <input type="checkbox"/> Operational Flexibility/Off Permit Notification for a SOP <input type="checkbox"/> Revision for a GOP <input type="checkbox"/> To be Determined <input type="checkbox"/> None		
Identify the type(s) of FOP issued and/or FOP application(s) submitted/pending for the site. (<i>check all that apply</i>)		
<input type="checkbox"/> SOP <input type="checkbox"/> GOP <input type="checkbox"/> GOP application/revision (submitted or under APD review) <input type="checkbox"/> N/A <input type="checkbox"/> SOP application/revision (submitted or under APD review)		
III. Fee Information (go to www.tceq.texas.gov/epay to pay online)		
A. Fee Amount:		
B. Voucher number from ePay:		
IV. Public Notice (if applicable)		
A. Responsible Person (<input checked="" type="checkbox"/> Mr. <input type="checkbox"/> Mrs. <input type="checkbox"/> Ms. <input type="checkbox"/> Other:)		
Name: Robert Webb		
Title: Owner		
Company: Wilbarger Humane Society		
Mailing Address: 2805 Sullivan St.		
City: Vernon	State: TX	ZIP Code: 76384
Phone: 940-839-5825	Fax No.:	
Email Address: fluidpisher8246@att.net		

**Texas Commission on Environmental Quality
Form PI-1S
Registrations for Air Standard Permit
(Page 5)**

IV. Public Notice (continued) (if applicable)		
B. Technical Contact (<input checked="" type="checkbox"/> Mr. <input type="checkbox"/> Mrs. <input type="checkbox"/> Ms. <input type="checkbox"/> Other): _____		
Name: Luis Llorens		
Title: President/Project Manager		
Company: AI ENVIRONMENTAL CONSULTING SERVICES, INC./U.S. Cremation Equipment		
Mailing Address: 2140 Silver Star Road Suite 201-D		
City: Orlando	State: Florida	ZIP Code: 32808
Phone No.: 407-923-3945	Fax No.: 321-282-7358	
Email Address: Ai@cfl.rr.com		
C. Bilingual Notice		
Is a bilingual program required by the Texas Education Code in the School District?	<input checked="" type="checkbox"/> Yes <input type="checkbox"/> No	
Are the children who attend either the elementary school or the middle school closest to your facility eligible to be enrolled in a bilingual program provided by the district?	<input checked="" type="checkbox"/> Yes <input type="checkbox"/> No	
If "Yes," list which language(s) are required by the bilingual program? Spanish		
D. Small Business Classification and Alternate Public Notice		
Does this company (including parent companies and subsidiary companies) have fewer than 100 employees or less than \$6 million in annual gross receipts?	<input checked="" type="checkbox"/> Yes <input type="checkbox"/> No	
Is the site a major source under 30 TAC Chapter 122, Federal Operating Permit Program?	<input type="checkbox"/> Yes <input checked="" type="checkbox"/> No	
Are the site emissions of any individual regulated air contaminant equal to or greater than 50 tpy?	<input type="checkbox"/> Yes <input checked="" type="checkbox"/> No	
Are the site emissions of all regulated air contaminant combined equal to or greater than 75 tpy?	<input type="checkbox"/> Yes <input checked="" type="checkbox"/> No	
V. Renewal Certification Option		
A. Does the permitted facility emit an air contaminant on the Air Pollutant Watch List, and is the permitted facility located in an area on the watch list?	<input type="checkbox"/> Yes <input type="checkbox"/> No	
B. For facilities participating in the Houston/Galveston/Brazoria area (HGB) cap and trade program for highly reactive VOCs (HRVOCs), do the HRVOCs need to be speciated on the maximum allowable emission rates table (MAERT)?	<input type="checkbox"/> Yes <input type="checkbox"/> No	
C. Does the company and/or site have an unsatisfactory compliance history?	<input type="checkbox"/> Yes <input type="checkbox"/> No	
D. Are there any applications currently under review for this standard permit registration?	<input type="checkbox"/> Yes <input type="checkbox"/> No	

**Texas Commission on Environmental Quality
Form PI-1S
Registrations for Air Standard Permit
(Page 6)**

V. Renewal Certification Option (<i>continued</i>)	
E. Are scheduled maintenance, startup, or shutdown emissions required to be included in the standard permit registration at this time?	<input type="checkbox"/> Yes <input type="checkbox"/> No
F. Are any of the following actions being requested at the time of renewal:	<input type="checkbox"/> Yes <input type="checkbox"/> No
1. Are there any facilities that have been permanently shutdown that are proposed to be removed from the standard permit registration?	<input type="checkbox"/> Yes <input type="checkbox"/> No
2. Do changes need to be made to the standard permit registration in order to remain in compliance?	<input type="checkbox"/> Yes <input type="checkbox"/> No
3. Are sources or facilities that have always been present and represented, but never identified in the standard permit registration, proposed to be included with this renewal?	<input type="checkbox"/> Yes <input type="checkbox"/> No
4. Are there any changes to the current emission rates table being proposed?	<input type="checkbox"/> Yes <input type="checkbox"/> No
<i>Note: If answers to all of the questions in Section V. Renewal Certification Option are "No," use the certification option and skip to Section VII. of this form. If the answers to any of the questions in Section V. Renewal Certification Option are "Yes," the certification option cannot be used.</i>	
*If notice is applicable and comments are received in response to the public notice, the application does not qualify for the renewal certification option.	
VI. Technical Information Including State and Federal Regulatory Requirements	
Place a check next to the appropriate box to indicate what you have included in your submittal.	
<i>Note: Any technical or essential information needed to confirm that facilities are meeting the requirements of the standard permit must be provided. Not providing key information could result in an automatic deficiency and voiding of the project.</i>	
A. Standard Permit requirements (Checklists are optional; however, your review will go faster if you provide applicable checklists.)	
Did you demonstrate that the general requirements in 30 TAC Sections 116.610 and 116.615 are met?	<input checked="" type="checkbox"/> Yes <input type="checkbox"/> No
Did you demonstrate that emission limitations in 30 TAC Sections 106.261 and 106.262 are met?	<input type="checkbox"/> Yes <input type="checkbox"/> No
Did you demonstrate that the individual requirements of the specific standard permit are met?	<input type="checkbox"/> Yes <input type="checkbox"/> No
B. Confidential Information (All pages properly marked "CONFIDENTIAL")	<input type="checkbox"/> Yes <input checked="" type="checkbox"/> No
C. Process Flow Diagram	<input checked="" type="checkbox"/> Yes <input type="checkbox"/> No

**Texas Commission on Environmental Quality
Form PI-1S
Registrations for Air Standard Permit
(Page 7)**

VI. Technical Information Including State and Federal Regulatory Requirements (continued)	
Place a check next to the appropriate box to indicate what you have included in your submittal.	
<i>Note: Any technical or essential information needed to confirm that facilities are meeting the requirements of the standard permit must be provided. Not providing key information could result in an automatic deficiency and voiding of the project.</i>	
D. Process Description	<input checked="" type="checkbox"/> Yes <input type="checkbox"/> No
E. Maximum Emissions Data and Calculations	<input checked="" type="checkbox"/> Yes <input type="checkbox"/> No
F. Plot Plan	<input checked="" type="checkbox"/> Yes <input type="checkbox"/> No
G. Projected Start Of Construction Date, Start Of Operation Date, and Length of Time at Site:	<input checked="" type="checkbox"/> Yes <input type="checkbox"/> No
Projected Start of Construction (provide date): October 2026	
Projected Start of Operation (provide date): October 2026	
Length of Time at the Site: 1 week max.	
VII. Delinquent Fees and Penalties	
This form will not be processed until all delinquent fees and/or penalties owed to the TCEQ or the Office of the Attorney General on behalf of the TCEQ are paid in accordance with the Delinquent Fee and Penalty Protocol. For more information regarding Delinquent Fees and Penalties, go to the TCEQ website at: www.tceq.texas.gov/agency/financial/fees/delin/index.html .	
VIII. Signature Requirements	
The signature below confirms that I have knowledge of the facts included in this application and that these facts are true and correct to the best of my knowledge and belief. I further state that to the best of my knowledge and belief, the project for which application is made will not in any way violate any provision of the Texas Water Code (TWC), Chapter 7; the Texas Health and Safety Code, Chapter 382, the Texas Clean Air Act (TCAA) the air quality rules of the Texas Commission on Environmental Quality; or any local governmental ordinance or resolution enacted pursuant to the TCAA. I further state that I understand my signature indicates that this application meets all applicable nonattainment, prevention of significant deterioration, or major source of hazardous air pollutant permitting requirements. The signature further signifies awareness that intentionally or knowingly making or causing to be made false material statements or representations in the application is a criminal offense subject to criminal penalties.	
Name (printed): Robert Webb	
Signature (original signature required):	
Date:	
IX. Copies of the Registration	
The PI-1S application must be submitted through ePermits. No additional copies need to be sent to the Regional Office or local Air Pollution Control Program(s). The link to ePermits can be found here: www3.tceq.texas.gov/steers/ .	