

LEADS Valve Driver Interface Board (07209)

Circuit Schematic

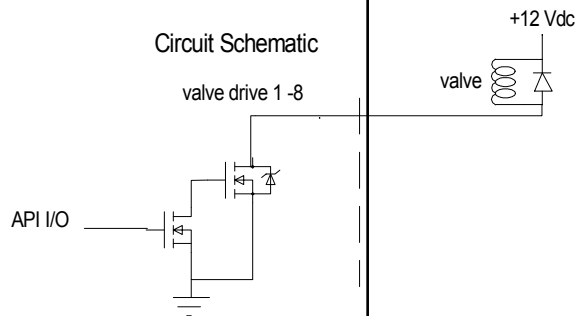

be sure to use (07209) board, switches to ground.

Alpha 5388C
18 AWG 8 Conductor
300 V Multiconductor
Foil Shield Cable

3 Pin Molex
Female Plug
Female Pin
on Valve Assembly

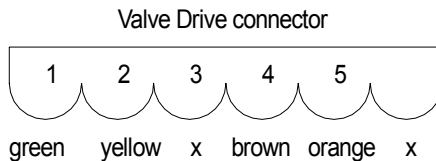

rev A: added H2S Control In

REVIEWED		DATE		T C E Q	
DRAWN: O. Moreno		02-10-13		CAMS STATION TERMINAL STRIP INTERCONNECTION	
CHECKED: Hernandez		4-15-15		DWG. NUMBER	
TIME:		SIZE A		REV A	
File Name: API_Terminal_Strip_rev_A.skf		SHEET 1 OF 1		DATE: 4-15-15	