

CLIMATRONICS F460

WIND CABLE, CLIMATRONICS PN 100605-50
(SUPPLIED WITH F460 CROSS ARM)

SUTRON ASSEMBLY CHASSIS

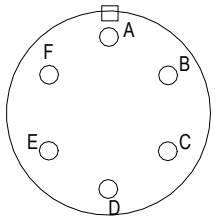

MS 3102R14S-6P
(EXITING CONNECTOR
ON CROSS ARM)

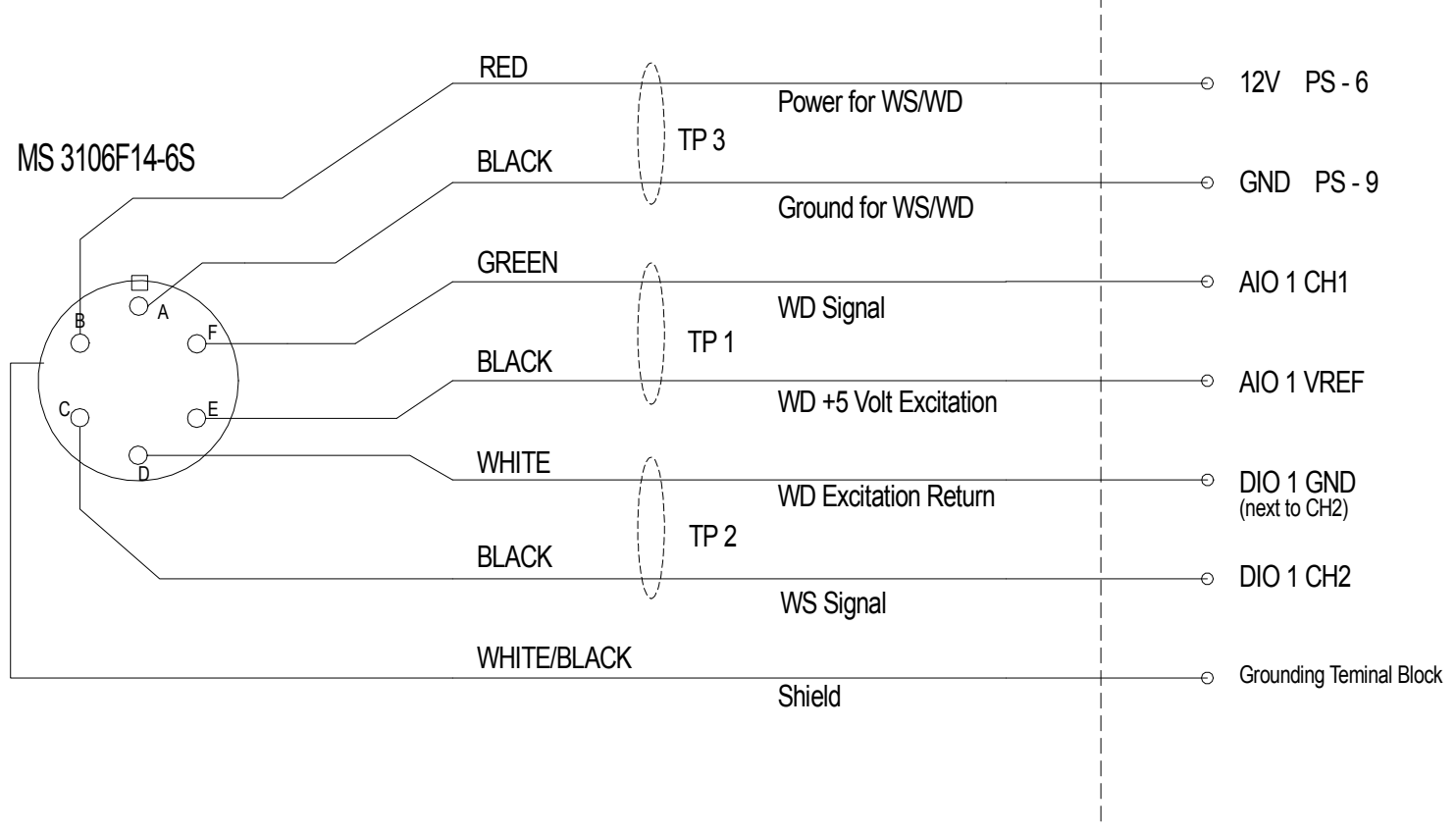

NOTE: MS connectors shown from wiring side.

REVIEWED		DATE	TITLE	
DRAWN: Hernandez		08-08-12	Climatronics F460 CROSS ARM to SUTRON	
CHECKED: Randolph		??-??-00	DWG. NUMBER	REV A
TIME:		SIZE A	SHEET 1 OF	1
File Name: Wind_Cable_SUTRON.skf			DATE: 08-08-12	