

GUIDELINES FOR STACK SAMPLING FACILITIES

Formerly “Chapter 2, Stack Sampling Facilities” of the TCEQ Sampling Procedures Manual

General

The following guidelines should be utilized for safe and accessible stack sampling configuration and conditions. No attempt has been made to incorporate any official safety rules, but all such applicable requirements should be followed. These guidelines do not and are not intended to waive compliance with any law regarding safety which is applicable for the location and activities conducted at the location of the facilities to be sampled.

These guidelines cannot anticipate all situations, and special cases will occur. Non-standard or alternate installations are therefore evaluated on an individual basis, and in such instances detailed plans should be sent to the local TCEQ Regional Office sufficiently in advance for review and approval before the construction of stack sampling equipment is initiated.

Most sampling for representative results requires appropriate sampling equipment for which the TCEQ has established the guidelines presented in this document.

Various regulations require that safe and easy access be provided for sampling. If a TCEQ observer determines that the conditions for sampling activities would be unsafe, crowded, or otherwise dangerous, the observer may preclude the observation of the sample and, in turn, the acceptance of any results.

Physical Features

Stack sampling operations utilize a system of equipment to traverse a cross-section of the stack or duct through ports located such that a representative sample can be obtained. Typically, a monorail structure is erected so the cross-section of the stack may be traversed on two axes for circular stacks and on a matrix layout for rectangular or other shaped stacks. Before consideration is given to the installation of sampling ports and platforms, certain dimensions and other features of the stack and stack gas should be verified to ensure a representative sample is possible.

- Stack diameter should be at least four inches.
- Stack gas velocity pressure head should be at least 0.05 inches of water or a low flow manometer, capable of greater sensitivity should be made available.
- The stack should have a uniform undisturbed run of at least 2.5 stack diameters clear of any disturbance. The port should be located at a minimum, 2 stack diameters from a disturbance following the flow of the gas stream to the port, commonly referred as “downstream” by United States Environmental Protection Agency (USEPA) Title 40 Code of Federal Regulations Part 60, Appendix A Method 1 (USEPA Method 1); and 0.5 stack diameters from a disturbance going against the gas stream to the port, commonly referred to as “upstream” by USEPA Method 1. Alternative methods may be approved by the administrator.

Sampling Ports

Port Location

The USEPA criteria for optimum location of sampling ports is (1) at least eight stack diameters downstream from any flow disturbance; and (2) at least two stack diameters upstream from a flow disturbance. A duct diameter is used for non-circular stacks and is defined later in this guidance. This location permits a sample traverse to be taken using a minimum of twelve sampling points. A greater number of sampling points is necessary on stacks which fail to meet these location criteria. If a minimum 0.5 diameter upstream and 2 diameters downstream criteria from a port location is not available, then stack modification should be made or an alternate sampling location should be chosen which will satisfy this criteria. Alternatively, administrator approved methods may be used.

To minimize an increase in the number of sampling points necessary on stacks with an undisturbed cross-section less than 10 but greater than 2.5 stack diameters in length, the sampling ports should be located such that the distance from the ports to the nearest upstream disturbance is four times the distance from the ports to the nearest downstream disturbance. Due to varying stack shapes, refer to USEPA Method 1 to determine acceptable port location(s).

Port Size

For stacks that are constructed of 3/16 inch or greater thickness metal, ports should be a minimum three-inch internal diameter standard industrial flanged pipe with a six-inch bolt circle diameter and closed by a removable blind flange. Larger port sizes are necessary on large diameter, double-walled stacks which necessitate longer ports, and six-inch ports are necessary for proportional PM-10 sampling. The larger-size ports should also be standard industrial flanged pipe. Ports, no smaller than four inches in internal diameter, should be used on stacks greater than ten feet in diameter.

Port Installation

Ports should be installed flush with the interior stack wall and should extend outward from the exterior stack wall no less than three inches nor more than eight inches unless additional length is required for gate valves. Gate valves should be installed only when extreme stack conditions or the presence of hazardous materials require such devices for the safety of personnel. Ports should be installed no less than five feet nor more than six feet above the floor of the platform and the clearance zone described later in this chapter should be maintained.

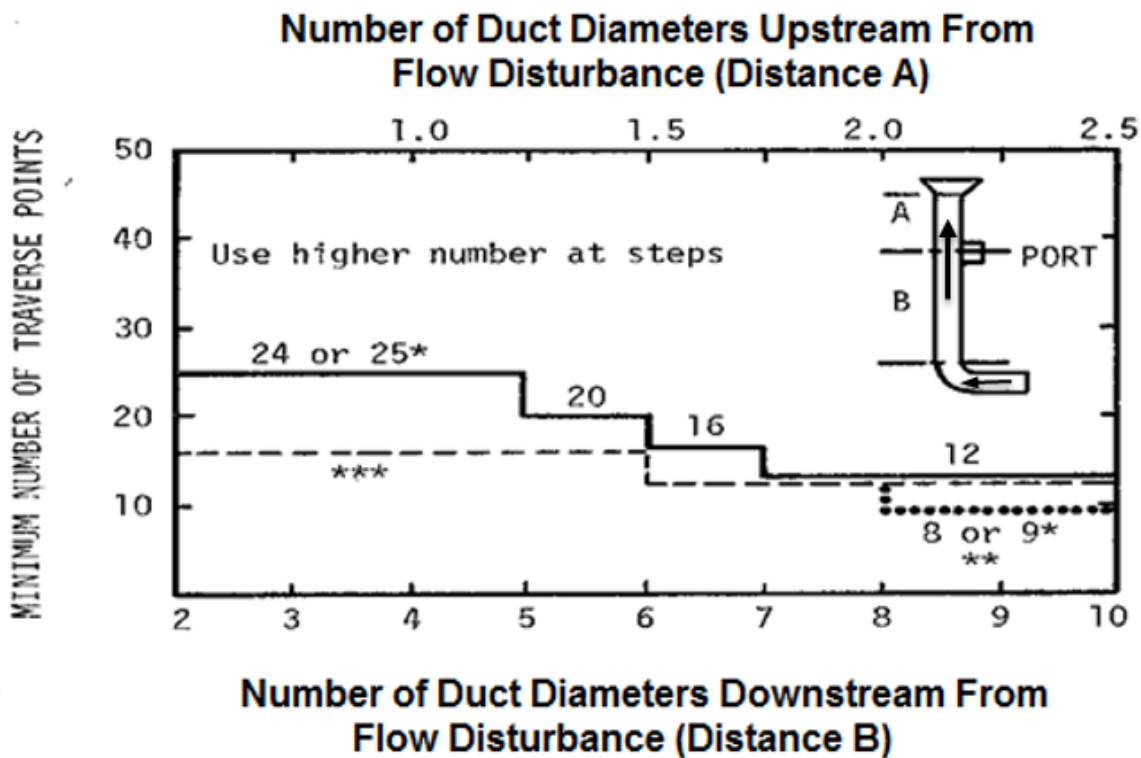

*Higher number is for rectangular stacks or ducts.
 **Dotted line is for stack diameter of one through two feet (particulate and velocity traverses).
 ***Dashed line is for velocity traverses only (gaseous sampling).

Figure 1 - Minimum Number or Traverse Points

Number and Location of Ports on Circular Stacks

A minimum of two ports should be installed on diameters ninety degrees (90°) apart if the stack diameter plus one port length (stack inside wall to end of port extension) is less than ten feet. Four ports should be installed on diameters 90° apart if the stack diameter plus one port length is equal to or greater than ten feet. One traverse should be located in the plane of any bend or other disturbance that may have inertial effects on particles in the flow stream.

Number and Location of Ports on Non-Circular Stacks

The upstream and downstream distance requirements discussed in previous sections of this guidance also apply to non-circular stacks. The duct diameter (four times the area divided by the perimeter) is used in place of the circular diameter. This becomes $(2AB)/(A+B)$ for a rectangular stack, where A and B are the cross-sectional dimensions of the stack. The stream wise location of the sampling ports is determined in the same manner as for circular stacks using the duct diameter. The duct diameter is used only for determining the location of sampling ports and the required number of sampling points. The duct diameter is not used in data reduction.

The cross-stream location of the sampling ports is dependent upon the total number of sampling points required. Refer to USEPA Method 1 to determine the minimum number of sampling points by reading the curve corresponding to the number of upstream duct diameters (A) and downstream duct diameters (B) and selecting the higher number.

The stack cross-section of square or rectangular stacks is divided into a matrix (i, j) of equal area rectangles such that $i = j$ or $i = j \pm 1$ and $i + j$ is equal to or greater than the total number of sampling points required. The number of necessary sampling ports is either i or j located along one side of the stack such that the centerline of each port is collinear with the centroid of each row of sampling points.

Stacks with cross-sections which are not circular, rectangular, or have unequal perpendicular diameters, the stack should be equipped with an adequate arrangement of sampling ports so that the stack cross-section may be divided into a sufficient number traverse points for a representative sample. If equal area increments are not possible, time weighting of the sample at the various sampling points may be necessary. Due to varying stack shapes, refer to USEPA Method 1 to determine acceptable port location(s). Detailed plans of such installations should receive advance approval by the TCEQ to ensure representative sampling will be achieved.

Monorail Support Structure

The installation of a permanent monorail support structure is recommended to reduce set-up time and to eliminate the load-bearing requirements for the sampling ports. This bracket is intended to be compatible with several types of sampling equipment. The loading requirements for ports or the monorail support structure are shown below.

Source operators are encouraged to install permanent monorail systems on large stacks. Monorails should extend the full radial length of the clearance zone, described below. Rollers should be properly lubricated and maintained in working condition. The sample box attachment hooks should be six inches above the port centerline. If the monorail is installed with the hooks more than six inches above the port centerline, suitable adapters should be provided.

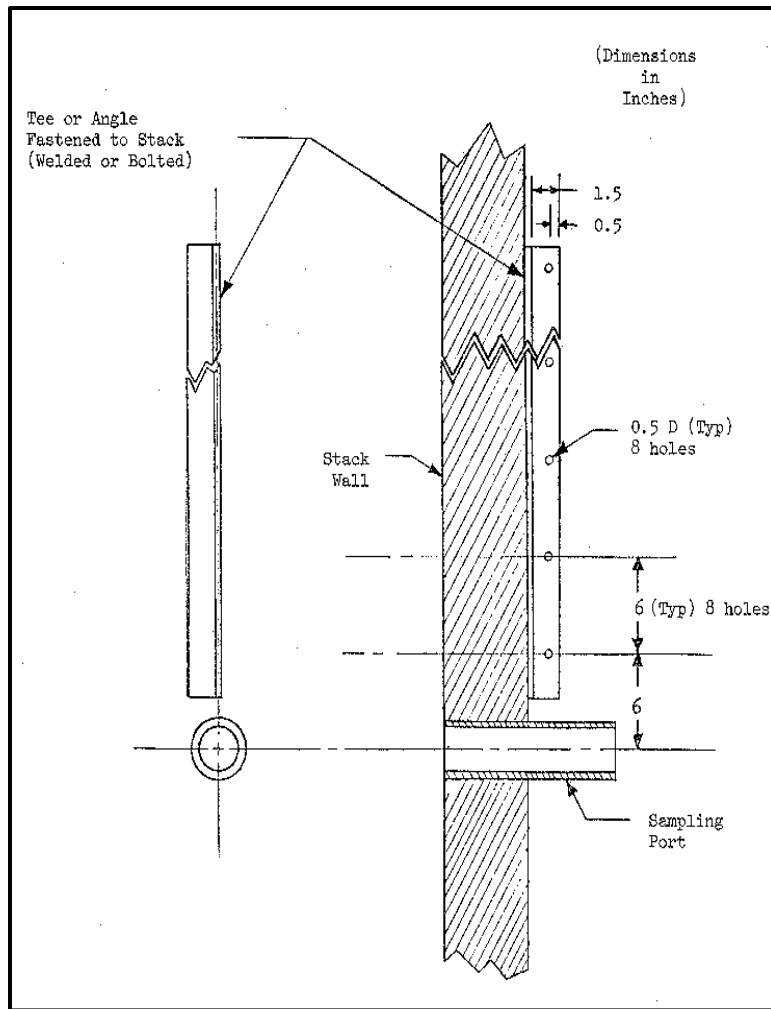

Figure 2 - Monorail Support

Port or Monorail Support Loading

The port or monorail support installation should be capable of supporting the following loads:

- Vertical load of 200 pounds
- Horizontal load of 200 pounds
- Radial load of 1000 pounds (along stack diameter)

Work Platform

A work platform should be provided around the stack perimeter between the sampling ports and extend at least five feet beyond each port. If four ports are used, the work platform should extend around the entire perimeter of the stack. The minimum platform width should be at least five feet measured radially with stack diameter. The work platform should be capable of supporting at least 2000 pounds.

Safe and easy access to the work platform should be provided via ladder, stairway, or other suitable means. Safe guardrails should be provided around the platform. No open ladder well, stairwell, or other such opening should be located within five feet of any sampling port. Ladder wells should be covered at the platform and any opening to the platform should be equipped with a safety bar or chain at the opening.

A temporary work platform for sampling operations is acceptable if proper safety and accessibility is provided. All other requirements detailed in this document such as for monorails, ports, loading, clearance, and power should be met by the temporary equipment. If any there is any doubt on the proper installation, please refer to the standards in American Society of Mechanical Engineers (ASME) Steel Stacks (STS)-1-2011.

Clearance Zone

A three-dimensional obstruction-free clearance zone should be provided around each sampling port. The zone should extend one foot above the port, two feet below the port, and two feet to either side of the port. The zone should extend outward from the exterior wall of the stack at least one stack diameter (or stack radius, if four ports are used), plus one port length (inside wall to end of port extension) plus five feet. Although this clearance zone is generally adequate for most sampling efforts, adjustments can be made as necessary.

Power Supply

Power requirements may vary from site to site. The test personnel and source owner/operator should verify that adequate power is available prior to testing. For routine testing, electrical power outlets should be provided as follows:

Platform Power

At least one 120-volt, 15-amp, single phase, 60 hertz alternating current circuit with a grounded, two-receptacle weather-proof outlet. Receptacles should accept standard three-prong grounded household-type plugs or suitable adapters should be provided. Should any issues arise, please refer to the National Fire Protection Association (NFPA) 70: National Electrical Code

Stack Base Power

Two 120-volt, 15-amp, single phase 60 hertz alternating current circuits with grounded, two-receptacle weather-proof outlets. Receptacles should accept standard three-prong grounded household-type plugs or suitable adapters should be provided. Should any issues arise please refer to the NFPA 70: National Electrical Code.

Vehicle Access and Parking

Vehicle access and parking space should be provided near the base of the stack for various communications and equipment transport lines to be strung to the stack platform.

Gaseous Sampling - Concentration Only

Standard sampling ports and platforms are typically necessary for gaseous sampling because a velocity traverse is needed for flow rate determination in most cases. In sampling situations for which only pollutant concentration is needed or for which an accurate flow rate is available by other approved methods, sampling equipment that does not meet all of the recommendations for standard sampling ports may be acceptable. All equipment should, however, meet strength and safety requirements.

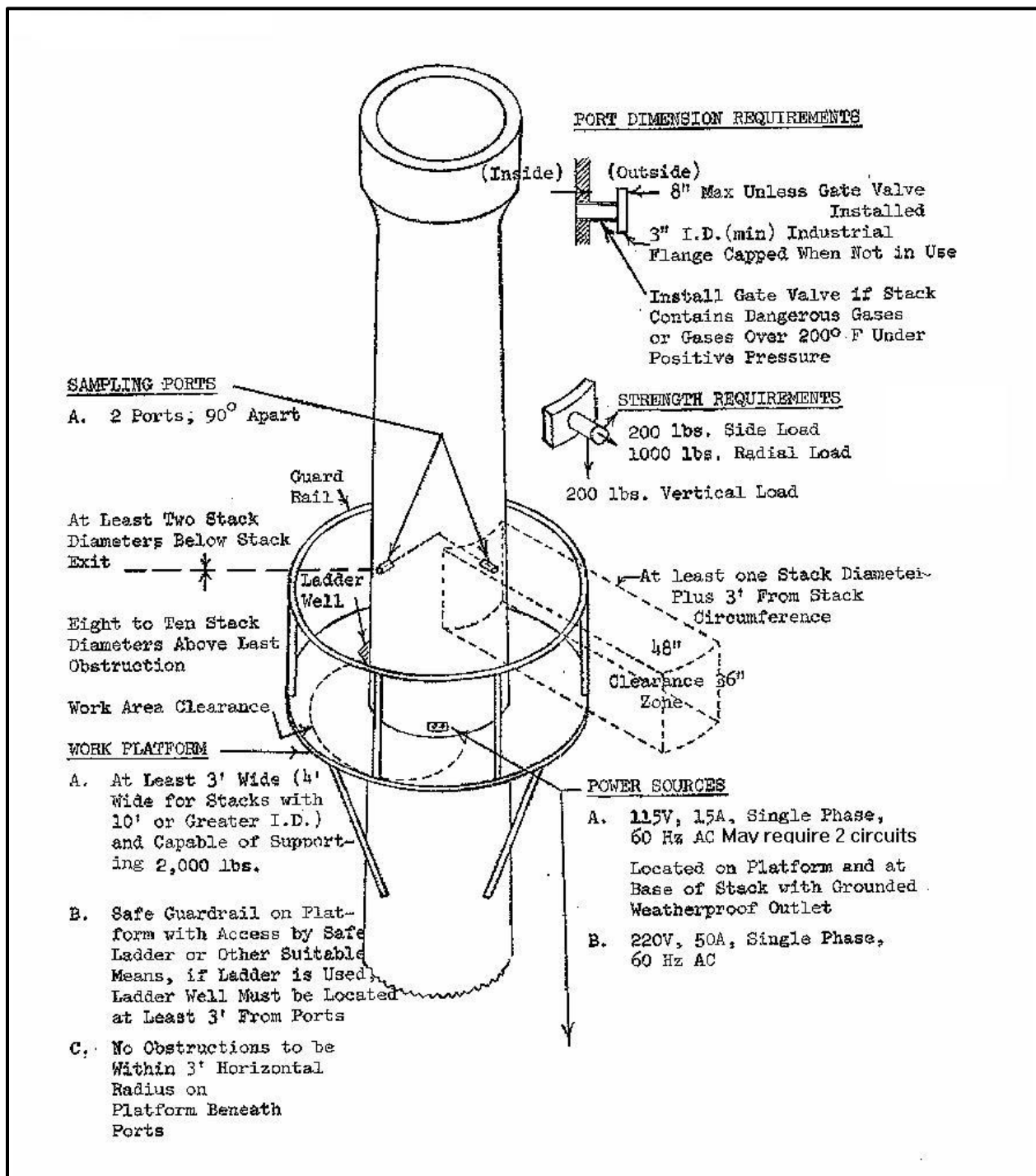

Figure 3 - Stack Equipment

Other Considerations

- Power hoists should be provided for sampling platforms 200 feet or more above ground level.
- Non-circular horizontal ducts should have provisions for vertical sampling. Circular horizontal ducts should have one vertical and one horizontal port. Suitable work platforms are necessary in both cases.
- Heat insulation should be installed as necessary on high temperature stacks for safety in the vicinity of the work platform.

Rev. July 19, 2016

- The sampling equipment should be maintained in a safe, useable condition at all

- times.
- Stacks may taper by as much as 15° without the taper being considered a disturbance.

Cyclonic Flow

Cyclonic or swirling flow may be encountered in a stack or duct due to certain circumstances such as cyclone collectors or tangential duct entry. The existence of cyclonic flow may be determined as described in 40 Code of Federal Regulations, Part 60, Appendix A, Reference Method 1. Corrective measures such as straightening vanes may be necessary to alleviate the cyclonic condition.