

Texas Commission on Environmental Quality

Water Supply Division

Common Issues with Low Pressure Membrane Treatment Plants

The section numbering in this document corresponds to the references in the TCEQ's document, Low Pressure Membrane Treatment Plant Checklist.

A. Background

When a water source has been designated by the TCEQ to be surface water or groundwater under the influence of surface water (GUI), the public water system (PWS) must treat the water from that source to meet the surface water treatment rule requirements located in Title 30 of the Texas Administrative Code (30 TAC) Chapter 290, Subchapter 111 (§290.111). The surface water rule requirements that apply to a specific water source depend on the size of the PWS (as defined by the population served and/or number of service connections), the characteristics of the PWS's customers (transient, non-transient, or community), and the concentrations of pathogens in the source water. The pathogens of primary concern in the surface water treatment rules are viruses and two types of parasites, *Giardia lamblia* and *Cryptosporidium parvum*. All surface and GUI water sources are subject to the following general requirements:

1. Pathogen Removal

Treatment facilities must be capable of removing an amount of pathogens specified by the TCEQ. Membrane filtration removes pathogens as follows:

- Always includes filtration through a specific model of membrane that has been approved by the TCEQ for removal of *Giardia* and *Cryptosporidium*.
- Often includes strainers ahead of the membranes to remove debris and large particles.
- Sometimes includes the addition of a chemical coagulant ahead of the strainers and membranes. A clarification step may be included after the addition of a chemical coagulant.
 - When a coagulant like alum is added ahead of the membranes, some virus removal credit may be granted to the membranes.
 - When no coagulant is added ahead of the membranes, no virus removal credit is granted to the membranes.

Note that the TCEQ's rules for public water systems do not fully define the design and operation requirements for membranes that are granted pathogen removal credit. Instead, site specific rules are generated for each membrane plant through rule exceptions for innovative/alternate treatment processes. The exception letters that are issued for membrane plants specify how much and under what conditions pathogen removal credit will be granted to the membrane filters.

2. Pathogen Inactivation

Treatment facilities must include disinfection to inactivate an amount of pathogens specified by the TCEQ. Common disinfectants are free chlorine and chloramines. Less common disinfectants are chlorine dioxide, ozone, and ultraviolet (UV) radiation.

- a. The amount of pathogen inactivation that is achieved is a function of both the disinfectant concentration and time of exposure to the disinfectant. TCEQ refers to this as a Concentration-Time (CT) calculation. Other factors that affect the CT calculation are water temperature and pH.
- b. The amount of inactivation that can be achieved differs from treatment plant to treatment plant. PWSs are required to submit a CT Study for each surface water and GUI treatment plant that describes the treatment units that are available for disinfectant contact time and the specific disinfectants that will be used. Worst case conditions of temperature, pH, flow rate, and disinfectant concentration are used to determine the minimum level of pathogen inactivation the treatment plant should be able to achieve reliably.

(If you would like more detailed information about pathogen removal and inactivation, please refer to the document located on the TCEQ's website at the following link:

https://www.tceq.texas.gov/assets/public/permitting/watersupply/pdw/EG_Meeting_Treatment_Technique_Requirements_for_CGV_20191015.pdf)

3. Monitoring

The treatment facilities must be monitored to ensure that the required amounts of pathogen removal and inactivation are occurring.

- a. It is difficult and expensive to monitor pathogen concentrations directly. Also, the laboratory methods for analyzing pathogens are not instantaneous. By the time the laboratory produces pathogen test results, the water has already been drunk by PWS's customers.
- b. Since we can't monitor for pathogens instantaneously, the federal and state surface water treatment rules provide design and monitoring requirements for specific treatments that have been proven to remove pathogens. For example, a plant with coagulation, flocculation, sedimentation, and granular media filters that was built according to minimum standards is operated in compliance with the rules and meets the required turbidity levels. Turbidity levels are always monitored after conventional filtration facilities. For conventional media filters, if the turbidity remains below specified levels, the TCEQ accepts that the required amounts of pathogen removal have been achieved.
- c. Low-pressure membrane filtration (ultrafiltration or microfiltration) is a different treatment technology approved by EPA and TCEQ to remove pathogens as long as the design and operation of the facilities meet the federal and state requirements. Turbidity is monitored, but unlike conventional filters, the direct integrity test is the most important test performed on the membrane units to show the units are capable of removing the type and amount of pathogens found in your PWS's source water:
 - Direct integrity tests (DITs, may also be called Membrane Integrity Tests, MITs, Integrity Tests, ITs, or Air Hold Tests, AHTs) must be performed on low-pressure membranes to ensure that the membranes are intact. In other words, no holes have formed that are large enough for *Giardia* cysts and *Cryptosporidium* oocysts to pass through.
 - Turbidity is also monitored after each membrane unit. A high turbidity level requires the PWS to perform a DIT but does not necessarily mean the membrane unit is a risk to public health. The DIT must be performed immediately if a high turbidity level is experienced to determine if the membrane unit needs to be repaired.
- d. The combination of disinfectant concentration (residual), temperature, flow rate, and pH must be monitored to determine how much pathogen inactivation is

occurring while the treatment plant is in operation. These parameters can fluctuate during each day of plant operation, so amounts of pathogen inactivation also fluctuate. The TCEQ specifies when these readings must be collected to ensure that all of the water treated in the plant on any given day meets or exceeds a required amount of pathogen inactivation.

We recommend that you obtain an up-to-date copy of the TCEQ's regulatory guidance document RG-211, Monthly Testing and Reporting at Surface Water Treatment Plants (2021 revision) for detailed monitoring instructions.

4. Reporting

The primary tool used by the TCEQ to verify that low pressure membrane treatment plants have met pathogen removal and inactivation requirements is the Surface Water Monthly Operating Report – Alternative Technologies (SWMOR-Alt). As the name implies, an SWMOR-Alt must be generated on a monthly basis and submitted to the TCEQ. The SWMOR-Alt is a Microsoft Excel-based spreadsheet.

- a. Daily monitoring data is input into the SWMOR-Alt by the plant operator each day. The SWMOR-Alt spreadsheet calculates compliance with pathogen removal requirements. The SWMOR-Alt calculates the amount of pathogen inactivation each day of the month.
- b. The SWMOR-Alt generates a summary page for the treatment plant's performance. If requirements are not met based on the reported data, a page of violations is generated by the SWMOR-Alt.
- c. Current versions of the SWMOR-Alt spreadsheets are available for download on the TCEQ's website:

<https://www.tceq.texas.gov/drinkingwater/swmor/swmor/swmor-forms-and-instructions>

Alternate navigation instructions: from the TCEQ's home page, search for "SWMOR" and choose the page titled "Forms, Instructions, and Guidance for Surface Water Monthly Operating Reports (SWMORs)."

We recommend that you obtain an up-to-date copy of the TCEQ's regulatory guidance document RG-211, Monthly Testing and Reporting at Surface Water Treatment Plants (2021 revision) for detailed reporting instructions.

5. Record Keeping

Records of treatment plant monitoring, operational, and inspection data must be kept for specified periods of time (typically 2 - 10 years but can be longer).

- a. These records may be used to verify that the data reported in the SWMOR-Alt forms are correct. They may also be used to troubleshoot treatment, monitoring, and reporting issues.
- b. Records could be kept in the form of daily log sheets, lab sheets, inspection sheets, charts, printouts, electronic records, and possibly others. Electronic record keeping is particularly important for turbidity data and disinfectant residual data that are collected at 5 to 30 minute intervals. Large amounts of data are generated each day and it is often impractical to keep paper copies of those data for multiple years.

B. Common Treatment Issues

The TCEQ has observed the following treatment issues at low-pressure membrane treatment plants.

1. Membrane Filtration Issues

a. Installation of different membranes

When a membrane module has reached its useful life span and is replaced, even if it is replaced with the exact same membrane model as listed in the TCEQ's membrane approval letter, the PWS must notify the TCEQ. Substitution of a different model of membrane is not allowed even if the manufacturer claims it is the same. All membranes must undergo rigorous challenge testing to be approved for pathogen removal credit. When a manufacturer makes changes to a membrane model, the modified membrane must undergo a new challenge study and receive approval for use from the TCEQ.

b. Direct Integrity Tests (DITs)

DITs [some plants refer to these as Membrane Integrity Tests (MITs), Integrity Tests (ITs), or Air Hold Tests (AHTs)] are the most important measure of how well a low pressure membrane unit (train, rack, skid, etc.) is removing *Cryptosporidium* and *Giardia*. Membrane plants are required to conduct DITs regularly using parameters approved by the TCEQ to show that the membranes are intact and removing the required amount of pathogens. Membranes that fail a DIT must be removed from service, inspected, repaired (if necessary), and pass a DIT before returning to service. The parameters used during a DIT depend on the specific design of the membrane unit (train, rack, skid, etc.) and the number of membrane modules (for example, individual cartridges in the membrane unit) that are being used. Consequently, you may not increase or decrease the number of modules used without prior written approval from the TCEQ. For example, if your membrane plant's approval letters assume that each membrane unit will be operated with 48 membrane modules, you must run the DIT with 48 modules in operation. Running a DIT with more or less than the approved number of modules in a membrane unit invalidates the results of the test. If you do not know your TCEQ-approved DIT parameters or the current membrane unit design differs from the approved design in any way, please contact the TCEQ's Technical Review and Oversight Team at 512-239-4691 to discuss.

The Bin Classification of your membrane plant determines the required frequency for conducting DITs:

Bin 1 Membrane Plants - DITs must be conducted at least once every seven days on each membrane unit (train, rack, skid, etc.).

Bin 2, 3, or 4 Membrane Plants - DITs must be conducted every day on each membrane unit.

In membrane plants that use a pressure decay rate DIT, success or failure of a DIT is determined by the following:

DIT Pass: both of the following conditions must be true

- Minimum pressure during the DIT must be greater than or equal to P_{test} , the minimum test pressure to detect a 3.0 micron (μm) defect in the TCEQ's DIT parameter approval letter.
- DIT Pressure Decay Rate must be less than or equal to the Upper Control Limit (UCL) in the TCEQ's DIT parameter approval letter.

DIT Fail: one or more of the following conditions is true

- Incomplete DIT – the membrane control system stops the DIT before the pressure decay portion of the procedure starts. No start pressure, stop pressure, and test duration is recorded. For example, the starting pressure won't stabilize at the beginning of the DIT. Although an incomplete DIT is not technically a failed DIT – there is no DIT data to report – your control system should, at a minimum, trigger an alarm so you can check to see why the DIT was incomplete and manually start another DIT. You should not allow a membrane unit that cannot complete a DIT to continue operating.
- Minimum pressure during the DIT is less than P_{test} , the minimum test pressure to detect a 3.0 μm defect in the TCEQ's DIT parameter approval letter.
- DIT Pressure Decay Rate is greater than the Upper Control Limit (UCL) in the TCEQ's DIT parameter approval letter. Pay particular attention to the units for the Pressure Decay Rate – it must be calculated in psi per minute to compare it to the approved UCL.

(The vast majority of low-pressure membrane plants in Texas use a pressure decay rate DIT. Plants that use an airflow rate DIT will use similar pass/fail criteria.)

Low-pressure membrane filters are operated in one of two modes: deposition (dead-end) mode or crossflow (suspension) mode. Deposition mode can be described simply as all of the water that is sent to the upstream side of the membrane passes through the membrane and all solid particles larger than the pore size in the membranes are deposited on the upstream side of the membranes. Crossflow (suspension) mode can be created in a variety of ways. One common method is where a portion of the water sent to the upstream side of the membrane does not pass through the membrane but crosses the upstream side of the membrane. The unfiltered water may be sent to waste, recycled back into the feed water of the same membrane unit, or sent for further treatment by a new membrane unit. This crossflow scours and removes some particles that have deposited on the upstream side of the membrane, extending the time between backwashes. Other forms of crossflow (suspension) mode include: pumping a flow of water opposite to the direction of the feed water during filtration or pumping air or vibrations into the modules or unit (when using membranes that are suspended in a tank) to remove particles from the feed side of the membranes during filtration.

The mode of operation has a significant impact on the TCEQ's approved DIT parameters. If the approved DIT parameters are based on deposition mode, the membrane filters must be operated in deposition mode (in other words, no crossflow is allowed). If the approved DIT values are based on crossflow mode, the membranes filters cannot be operated in deposition mode.

Many membrane units are designed with the capability to operate in both deposition and crossflow modes. Occasionally, a membrane manufacturer may state that the membrane units are operating in one mode but a close inspection of the units reveals the opposite. This is not always easy to detect. If there is any flow sent to the upstream side of the membranes that does not pass through to the filtered side of the membranes, the unit is operating in some kind of crossflow (suspension) mode.

- c. Failure to inject a chemical coagulant or use required pretreatment units when the membrane plant approvals require it

If the approval letters for your membrane plant assumed one of the following conditions:

- Coagulation and flocculation
- Coagulation, flocculation, and clarification

then your membrane plant was probably granted some virus removal credit. This removal credit reduced the amount of pathogen inactivation your membrane plant is required to achieve. If you subsequently stop adding a coagulant or stop using any of the required pretreatment units ahead of your membranes, all required virus treatment must be achieved by inactivation with disinfectants. Similar to granular media filters, low-pressure membrane filters operated without a coagulant are not effective for removing viruses.

The easiest way to tell if your membrane plant is improperly claiming virus removal credit is to look at the customizations in the SWMOR-Alt form used for the plant. On the Disinfection Data Page, pages 4 and 5 (or the tab labeled "P.4&5-Disinfection Data" if you are in the Microsoft Excel spreadsheet), examine the block labeled "PERFORMANCE STANDARDS" near the top of the page. If the number under "Viruses" is less than 4.0, then your SWMOR form is claiming some virus removal credit, probably through the use of a coagulant and specific pretreatment units. If you are not actually injecting a coagulant ahead of your membrane filters or you stop using or bypass your pretreatment units, the number under "Viruses" should be at least 4.0. Note that your SWMOR form was customized with the numbers taken directly from your plant's approved CT Study letter. If the number entered in your SWMOR form is wrong, then your CT Study is also wrong and must be revised to match actual conditions in your plant.

Operators are not allowed to choose between using and not using a coagulant or pretreatment units without TCEQ approval. If your TCEQ approval letters assume that a coagulant and specific pretreatment units are in use, you must continuously apply a coagulant to the treated water and you must use any required rapid mix, flocculation, and coagulation units. If your plant is approved for the use of a coagulant and your source water conditions change or for some other reason you think the membranes will function better without a coagulant or a pretreatment unit, you must obtain approval from TCEQ before you implement the change. The TCEQ will issue several separate approval letters before you are allowed to stop injecting a coagulant or stop using your pretreatment units:

- Revised Membrane Exception Letter
This letter may remove the operating requirement to add coagulant ahead of the membranes.
- Revised CT Study Letter
This letter may revise the virus inactivation requirement for the plant to 4.0-log and allow you to revise your SWMOR form accordingly.
- Revised DIT Letter
This letter may revise the DIT parameters to accommodate revised Giardia removal requirement for the membrane units.

- Notification of change to Plan Review Team

Changes to the chemical processes in the plant may affect the corrosivity of your water. You must submit a notification of the change and the anticipated change in finished water quality to the TCEQ's Plan Review Team.

Failure to inject a coagulant or use the approved pretreatment units when your plant's approval letters require it presents a potential threat to public health. If you need assistance clarifying coagulant and pretreatment requirements in your membrane plant, please contact the TCEQ's Technical Review and Oversight Team at 512-239-4691.

d. Membrane operation cycles

Membrane units (trains, racks, skids, etc.) run through an automated sequence of processes during normal operations. Here are the typical daily operation cycles for low-pressure membranes (they may be called something different at your plant):

- Filtration - the membrane unit is producing filtrate for use by the customers or the plant's internal cleaning processes. This cycle occurs many times per day.
- Backwash (backflush, etc.) - previously produced filtrate is flushed backwards through the membranes to remove particles that have accumulated on the upstream side of the membranes. This is often part of the normal cleaning process after a filtration cycle.
- Feed flush - unfiltered water is washed across the upstream side of the membranes to remove particles. Water does not pass through the membranes. This is often part of the normal cleaning process after a filtration cycle.
- Air scrub - air is passed across the upstream side of the membrane to remove accumulated particles. This is often done simultaneously with a backwash and is sometimes done during filtration.
- Maintenance clean - chemical cleaning solution, typically strong bases such as caustic (for organic compounds), strong acids such as citric acid (for inorganic compounds) or bleach solutions (for biological fouling), is circulated across and/or through the membranes. This often occurs once per day for a duration of less than 1 hour.

The membrane plant's design engineer or the membrane supplier conducted a study to determine the durations and frequencies for each of these processes during a normal day of operations. The TCEQ used the durations and frequencies to calculate the net capacity of your membrane filters. However, we have found that the submitted durations of backwashes, maintenance cleans, etc. often do not include additional time required to reset valves, refill the membranes, etc. between filtration cycles. All of the time not spent filtering water must be included with these processes. If the actual durations and frequencies of these processes in your plant are different than the assumptions used by the TCEQ in your membrane approval letter(s), the rated capacity of your plant may be too low or too high. Contact the TCEQ's Technical Review and Oversight Team at 512-239-4691 to discuss your membrane plant's daily operational cycles.

e. Chemical contamination of membrane units

Various chemical treatments are applied to low-pressure membrane units to remove fouling and restore capacity. There is a potential for chemicals that are applied to a membrane unit to contaminate unfiltered and filtered water piping because there are connections between these pipes. Cross-connection controls must be installed on membrane units to prevent chemicals from contaminating the filtered water, backwash supply, and backwash drain lines as well as the feed water to other membrane units that are filtering water. Double block and bleed valving arrangements are typically used to protect membrane units against chemical contamination. Note that it is often difficult to look directly at the complex piping and cross-connection controls installed around a membrane unit to evaluate whether adequate protection exists. It is much easier to evaluate the cross-connection controls using the schematics of a membrane unit in the control system displays or in the construction plans. Always verify that the constructed pipes and valves around a membrane unit match the schematic.

TCEQ has provided some schematics of typical cross-connection controls around low-pressure membrane units in Appendix A. Some membrane units have more complicated piping connections. If you need assistance evaluating the cross-connection controls around your membrane units, please contact the TCEQ's Texas Optimization Program at 512-239-4691 or TOP@tceq.texas.gov.

f. Clean-in-Place (CIP) requirements

CIPs (sometimes called Recovery Cleans) are extended chemical treatments of membrane units that often last 5 - 24 hours and are designed to remove accumulated fouling and restore capacity to the membranes. Membrane suppliers often recommend that PWSs conduct a CIP on each membrane unit at a frequency of about 1 - 6 months. CIPs are a special maintenance activity and should be distinguished from shorter duration maintenance cleans. Maintenance cleans (sometimes called chemical washes) also use chemicals to treat the membranes but typically last about 30 minutes to 1 hour and are conducted several times per day to once every week. Because CIPs are harsh treatments that can potentially open up breaches in a membrane, the TCEQ requires that a membrane unit that has undergone a CIP must pass a DIT before the unit is placed back in service.

g. Turbidity spikes during membrane filtration cycles

The TCEQ has observed recurring turbidity spikes at some membrane plants. These spikes commonly occur immediately after a membrane unit starts a filtration cycle, particularly after a DIT, CIP, or other chemical maintenance activity. The spikes can last from a few seconds to more than 10 minutes. Severe spikes may exceed 154 mNTU.

Membrane plant operators often assume that the spikes are caused by air bubbles in the turbidimeter sample lines. At many of the plants that TCEQ has evaluated, there are actual suspended solids in the samples causing turbidity, not gas bubbles. Do not assume that the spikes are caused by air bubbles. Collect a sample from the turbidimeter drain line while the spike is occurring, allow the sample to sit for a few minutes so air bubbles are released, gently stir the sample to resuspend any solids that may have settled, and repeat the turbidity analysis. If there is still a significant measured turbidity in the sample, the turbidity is caused by actual solids in the sample. We have witnessed particles shedding off cavitating pumps and particles that weren't flushed properly out of the filtrate line after chemical cleans that cause turbidity spikes when filtration cycles start.

Membrane plant operators should evaluate and fix the causes of turbidity spikes. If air bubbles in the turbidimeter sample line are causing apparent turbidity

spikes, figure out how to eliminate the bubbles. There are many different types of bubble traps that operators have used, some more successful than others. If suspended solids are the cause, try changing how the previous maintenance activity is completed to attempt to reduce particle generation. If a combination of air bubbles and suspended particles are responsible for the spikes, address both issues. Recurring, uncontrolled turbidity spikes should not be accepted in a low-pressure membrane plant.

Regardless of the actual cause of the turbidity spikes, the spike data cannot be excluded from the reported maximum daily turbidity reported for each individual membrane unit. See Section D.8. for additional details.

2. Issues Common to All Types of Surface Water and GUI Treatment Plants

a. Potential treatment bypass

Any connection between unfiltered water and filtered/finished water, even if the pipes have valves that remain closed, represents a potential contamination hazard. These connections are not typically approved. If there is a valid reason to send filtered water back to a point in the plant ahead of the filters, it must be done through an air gap or reduced pressure backflow assembly. (In the case of membrane filters, if there is a direct piping connection between filtered and unfiltered water around a membrane unit, a double block and bleed valving arrangement or other approved method must be used to separate filtered from unfiltered water. For example, some membrane manufacturers use a common drain line for the filtered and unfiltered sides of a membrane unit that requires cross-connection protection. It is not a recommended practice to allow direct piping connections between unfiltered and filtered water around a membrane unit and this should be avoided, if possible.)

The TCEQ often finds cross-connections between filtered and unfiltered water in chlorine injection systems. Water from distribution is commonly used as motive water for injected chlorine gas. The motive water is piped to the chlorine injection points in the plant. When chlorine is injected at locations before and after the filters, it is not unusual to find direct connections between the unfiltered water and filtered water through the motive water lines. If the pressure in the motive water lines drops below the pressure at the injection points (for example, during a water outage or accidental valve closure), it becomes possible for unfiltered water to flow through the motive water lines to the filtered water side of the plant. A reduced pressure backflow assembly must be installed on motive water lines in a location that prevents unfiltered water from a pre-filter injection point from reaching any of the post-filter injection points. Usually, this device is placed on the motive water line(s) that supply the pre-filter chlorine eductors. Installation of a backflow prevention assembly on the main line that supplies the chlorine injection system does not prevent this cross-connection.

b. Disinfectant injection in unapproved locations

Your CT Study approval letter designates the locations where chemical disinfectants are allowed to be injected in the plant. Injecting disinfectants in unapproved locations within the treatment plant invalidates the disinfection process calculations in the SWMOR. If you need to move a disinfectant injection location, you must contact the TCEQ's Technical Review and Oversight Team at 512-239-4691 to discuss revising your CT Study and updating your SWMOR before you make the change.

c. Changes in flow paths of water through the treatment plant

Your approved CT Study models the flow of water through specific pipes, basins, storage tanks, etc. in the plant and calculates how long water takes to travel through those facilities for disinfection/inactivation calculations in the SWMOR. If you make any changes to the flow of water through the plant (for example, take one of two ground storage tanks offline for repairs or route a new source of water into the plant), your CT Study may no longer accurately model the plant. As a result, the CT calculations in the SWMOR may be invalidated and the plant may not be able to provide adequate disinfection. Before you make any changes to your plant that alter where water flows, contact the TCEQ's Technical Review and Oversight Team at 512-239-4691 to discuss the changes with respect to your CT Study and SWMOR customizations.

d. Lack of awareness of chemical doses

Chemical feed rates and chemical doses are related but are fundamentally different concepts. A chemical feed rate is simply the rate at which a chemical is added to a treatment process. Its units could be pounds per day or milliliters per minute. A chemical dose is the ratio of the chemical feed rate to the flow rate of treated water. The units of a chemical dose are some form of concentration, like milligrams per liter, pounds per million gallons, or parts per million. Here is an example to illustrate these two concepts:

- Chlorine is injected at a feed rate of 4.8 pounds per day into water flowing at 100 gallons per minute. After some math and units conversions, this chemical feed rate and treated water flow rate equate to a chlorine dose of 4 mg/L.
- The flow rate of water is doubled to 200 gallons per minute but the feed rate of chlorine stays the same, 4.8 pounds per day. The chlorine dose is half the previous amount, 2 mg/L. (The same amount of chlorine into twice as much water is half the dose.)

In water treatment, the chemical dose is a determining factor in how well a process like coagulation will work or if an adequate disinfectant residual will be carried through the treatment plant and distribution system.

Operators sometimes adjust chemical feed rates without calculating the resulting doses. This can be problematic when injecting chemicals that are not measured after injection, like coagulants and polymers. This can also be a problem when two chemicals are injected that react together, like chlorine and ammonia. In the latter case, TCEQ has observed situations where chlorine and ammonia are severely overfed, localized breakpoint chlorination occurs in poorly mixed water, and both chlorine and ammonia are wasted. Monitoring the residual concentrations of chlorine and ammonia after injection alone may not reveal what is happening. Knowledge of the chemical doses is important both for controlling the treatment processes and avoiding chemical waste.

C. Common Monitoring Issues

This section covers common issues associated with what, where, when, and how to monitor in a low-pressure membrane treatment plant. We recommend that you obtain an up-to-date copy of the TCEQ's regulatory guidance document RG-211, Monthly Testing and Reporting at Surface Water Treatment Plants (2021 revision) for additional monitoring instructions.

1. Misreporting membrane data

Some important data in a membrane plant is calculated from other monitored data. These calculations are typically programmed in one of two ways:

- Calculated in the membrane supplier's control system and then reported to the plant's SCADA system or directly to the plant operators, or
- Calculated in the plant's SCADA system and reported to the plant's operators.

There can be problems with both approaches. Membrane supplier control systems may not come customized to Texas-specific membrane requirements. The design engineer or plant operators must specify the calculations and monitoring requirements needed for the membrane control system to produce proper data for Texas membrane plants.

SCADA technicians are typically not drinking water operators or membrane plant experts. Membrane treatment calculations require unit conversions and long equations. Unless there is a review of the SCADA programming for accuracy by qualified professionals, reported data can be incorrect and programming issues can go undetected for years.

To help membrane plants confirm that their calculated membrane data is correct, the TCEQ has created a template for a daily membrane unit report. The template demonstrates what should be included in a daily membrane unit report to meet TCEQ reporting requirements. It is an Excel spreadsheet that takes membrane unit data that is recorded at 5-minute intervals on a given day (turbidity, transmembrane pressure (TMP), flow rate, water temperature) and calculates the data that should be reported in the membrane page of the SWMOR-Alt for that day (average Normalized Filter Flux, average TMP, average Normalized Specific Flux, Daily Maximum mNTU). If the data calculated by the membrane supplier's control system or the plant's SCADA system differ from the TCEQ's spreadsheet, there is an issue that needs to be investigated and addressed. The spreadsheet can be downloaded from the TCEQ's website at <https://www.tceq.texas.gov/drinkingwater/swmor/swmor/swmor-forms-and-instructions> .

a. DIT data

Two values are reported on the SWMOR-Alt for DITs: Pmin and pressure decay rate. Pmin is the lowest pressure found during a DIT. This will most likely occur at the end of the test and must remain above the TCEQ Ptest for the DIT to pass. Ensure that the pressures entered in the Pmin column are the minimum DIT pressures and not the starting pressures of the DITs. TCEQ changed this pressure reporting requirement in 2021.

The pressure decay rate for each DIT performed on a membrane unit (train, rack, skid, etc.) is a calculation that is performed either in the membrane supplier's control system, the plant's SCADA system, or, in rare cases, is manually performed by the operators. The equation for the pressure decay rate is relatively simple:

$$\text{Pressure Decay Rate} = \frac{\text{Start Pressure} - \text{Stop Pressure}}{\text{Test Duration}}$$

Where

Pressure Decay Rate is expressed in psi per minute.

Start Pressure = Pressure at the beginning of the DIT in psi.

Stop Pressure = pressure at the end of the DIT in psi.

Test Duration = elapsed time during the DIT in minutes. **Note: It is imperative that the Test Duration is expressed in minutes, not seconds! If the Test Duration is recorded in seconds, divide the value by 60 to convert it to minutes before completing the calculation.**

In the Treatment section of the Low-Pressure Membrane Treatment Plant Checklist, you are directed to manually calculate Pressure Decay Rates (psi per minute) during DITs on all of the membrane units in the plant. Compare the manually calculated values with the values recorded in the membrane control system or SCADA system. If the values don't match, troubleshoot and correct the error.

b. Normalized Filter Flux

The TCEQ uses the average Normalized Filter Flux to evaluate how membrane unit (train, rack, skid, etc.) performance changes over time. The TCEQ also compares daily Normalized Filter Flux to the approved design capacity of the membrane unit to verify that the membranes are being operated as assumed in the TCEQ's membrane approval letters. This parameter can be useful to operators especially to determine when: a problem began, a change in cleaning practices is needed to avoid irreversible fouling, or membrane units are reaching the end of their useful life.

Each low pressure membrane plant should report the average Normalized Filter Flux for each membrane unit on a daily basis in the SWMOR-Alt. A series of calculations is necessary to determine the Normalized Filter Flux when a membrane unit is in operation. The instantaneous filter flux is defined as the filtrate flow rate through the membrane unit divided by the total membrane surface area of all the membrane modules in the unit:

$$J = \frac{Q_p}{A_m}$$

(Equation 2.1 in the EPA's Membrane Filtration Guidance Manual, November 2005)

Where:

J = membrane unit filter flux in gallons per square feet per day (gfd)

Q_p = instantaneous filtrate flow rate in gallons per day (gpd) (Note that this is not the same as Q_p defined by the TCEQ in the approved DIT values letter.)

A_m = combined surface area of all the membrane modules in the membrane unit in square feet (ft²)

The viscosity of water decreases as the temperature of water increases. Water at 5 °C (41 °F) is approximately 2.5 times more viscous than water at 40 °C (104 °F). Water viscosity has a significant impact on the flow rate that can be pushed through a low-pressure membrane. Water at a higher temperature will flow more easily through a membrane than colder water. This effect makes it difficult to evaluate how well a membrane operates at 25 °C compared to the same membrane operating at 10 °C. Filter flux alone cannot be used to make the comparison. To standardize the comparison of the same membrane operating at different water temperatures, we "normalize" the filter flux to 20 °C by adjusting for the effect of water viscosity:

$$J_{20} = J_T \times TCF$$

(Equation 2.12 in the EPA's Membrane Filtration Guidance Manual, November 2005)

Where:

J_{20} = normalized filter flux at 20 °C (gfd)

J_T = actual filter flux at temperature T (gfd)

TCF = temperature correction factor (dimensionless, no units)

The TCF is the ratio of the viscosity of water at temperature T to the viscosity of water at 20 °C:

$$TCF = \frac{\mu_T}{\mu_{20}}$$

(Equation 2.11 in the EPA's Membrane Filtration Guidance Manual, November 2005)

Where:

μ_T = viscosity of water at temperature T in units of centipoise (cp)

μ_{20} = viscosity of water at 20 °C = 1 cp

The TCEQ has adopted the EPA's equation for estimating the viscosity of water (in cp) at different temperatures:

$$\mu_T = 1.784 - (0.0575 \times T) + (0.0011 \times T^2) - (10^{-5} \times T^3)$$

(Equation 2.8 in the EPA's Membrane Filtration Guidance Manual, November 2005)

Where:

T = water temperature in °C

Substituting for μ_T , TCF, and J_T in the earlier equations:

$$TCF = \frac{1.784 - (0.0575 \times T) + (0.0011 \times T^2) - (10^{-5} \times T^3)}{1 \text{ cp}}$$

$$J_{20} = J_T \times [1.784 - (0.0575 \times T) + (0.0011 \times T^2) - (10^{-5} \times T^3)]$$

$$J_{20} = \frac{Q_p}{A_m} \times [1.784 - (0.0575 \times T) + (0.0011 \times T^2) - (10^{-5} \times T^3)]$$

Normalized Filter Flux must be calculated at least once each day when the membrane unit is producing water to send to distribution at the maximum flow rate. It is highly recommended that you calculate it once every 15 or 30 minutes (depending on the length of the filtration cycle) when water is produced and average all the values calculated during the day. A good time to calculate the Normalized Filter Flux is after a backwash (backflush) once the unit has reached the flow set point so that accumulated particles are not impacting the rate at which water flows through the membrane.

c. Transmembrane Pressure (TMP)

It takes a significant amount of pressure to push water through membranes. An important measure of how much resistance to flow the membranes present is the pressure drop between the upstream and downstream sides of the membrane during filtration. This pressure drop is defined as the TMP. TMP is impacted by a number of factors:

- Water temperature - colder water is more viscous and it requires additional pressure to push colder water through a membrane.

- Accumulated fouling - particles that deposit on the upstream side of a membrane during a filtration cycle cause more resistance to flow. To maintain a constant flow (or flux) of water through a membrane, the TMP will increase during a filtration cycle to overcome the increase in fouling due to accumulated particles. Some fouling can be removed by backwashes and chemical cleaning between filtration cycles. Some membrane fouling is irreversible; it cannot be removed.
- Intrinsic membrane resistance - a new, clean membrane that has not been impacted by fouling has a baseline resistance to flow. There will always be a significant pressure drop across an intact membrane.

Membrane units have pressure transmitters/transducers installed on the upstream and downstream sides of the membranes to monitor TMP. The calculation of TMP is not necessarily straightforward. The following conditions must be taken into consideration:

- Is the membrane unit operating in deposition (dead-end) mode or in crossflow (suspension) mode? In crossflow mode, the pressure on the upstream side of the membrane varies with vertical position within the membrane module. The average pressure along the upstream side of the membrane is used in the TMP calculation.
- Are the pressure transmitters/transducers installed at different elevations within the membrane unit? If so, the measured pressures must be adjusted for relative height. This is based on the principle that pressure increases as depth of water increases. To be specific, increasing the depth of a column of water by 2.31 feet will increase the pressure by 1 psi. For example, assume that pressure transmitters are installed at the top and the bottom of a membrane unit, an elevation difference of 10 feet. To compare the pressure measured at the top of the unit with the pressure measured at the bottom, $10 \text{ feet} / 2.31 \text{ feet per psi} = 4.3 \text{ psi}$ must be added to the pressure measured at the top of the membrane unit.

The membrane suppliers program their control systems to adjust pressure readings monitored at different elevations and to adjust the calculation of TMP for deposition and crossflow modes of operation.

You can manually verify that the TMPs generated by your membrane control system are correct using these procedures:

- First, determine if your membrane unit is operating in deposition (dead-end) mode or crossflow (suspension) mode.
 - In deposition mode, locate the two pressure transmitters/transducers - one upstream of the membranes on the feed water line (we'll designate it as the feed pressure) and one downstream of the membranes (filtrate pressure).
 - In crossflow mode, locate the three required pressure transmitters/transducers - one upstream of the membranes on the feed water line (feed pressure), one for the flow that was directed across the upstream side of the membranes and possibly recirculated back to the feed water line (we'll designate this the retentate pressure), and one downstream of the membranes (filtrate pressure).

- Measure the height of each pressure transducer above a common reference point, for example, the floor. Adjust the pressure readings to that common reference elevation.
 - For example, there is a pressure transducer (PT1) located 3.5 feet above the floor and another (PT2) located 8 feet above the floor.
 - Add 3.5 feet / 2.31 feet per psi = 1.5 psi to the PT1 readings.
 - Add 8 / 2.31 = 3.5 psi to the PT2 readings.
- Note the pressure readings during filtration and the calculated TMP at a single instant in time. Calculate TMP manually and compare to the recorded TMP value.
 - If the pressure transducers display pressure, it would be a good idea to check if the control system is recording the same pressures that are displayed. If different values are displayed and recorded, you will have to figure out what is going on before proceeding. Contact your membrane vendor for assistance, if necessary.
 - Deposition (dead end) operation mode
 - $TMP = \text{feed pressure} - \text{filtrate pressure (deposition mode)}$
 - Before calculating TMP, adjust the pressure readings for the relative height of the pressure transducers.
 - Example: At 0845 AM on 7/24/2020, the feed pressure reading was 11 psi, the filtrate pressure reading was 5 psi, and the control system recorded a TMP of 3.9 psi. You determined previously that you should add 1.5 psi to the feed pressure reading and 3.5 psi to the filtrate pressure to adjust for elevation.
 - Adjusted feed pressure = 11 psi + 1.5 psi = 12.5 psi
 - Adjusted filtrate pressure = 5 psi + 3.5 psi = 8.5 psi
 - Manual TMP = 12.5 psi - 8.5 psi = 4.0 psi
 - Manual TMP, 4.0 psi, is close to the recorded TMP, 3.9 psi.
 - The recorded TMP value is reasonable.
 - Crossflow (suspension) mode of operation
 - $TMP = (\text{feed pressure} + \text{retentate pressure})/2 - \text{filtrate pressure (crossflow mode)}$
 - The first part of the equation, (feed pressure + retentate pressure)/2 is the average pressure along the upstream side of the membrane modules.
 - Before calculating TMP, adjust the pressure readings for the relative heights of the pressure transducers.
 - Example: at 15:30 on 9/7/2020, the feed pressure reading was 8.3 psi, the retentate pressure reading was 7.6 psi, the filtrate pressure reading was 6.2 psi, and the control system recorded a TMP value of 2.1 psi. The feed and retentate pressure transducers are located at the same

elevation and the filtrate pressure transducer is located 4 feet below the feed and retentate pressure transducers.

- Since the filtrate pressure transducer is 4 feet below the others, we must subtract 4 feet/2.31 feet per psi = 1.7 psi from the filtrate pressure reading to adjust for the elevation difference.
- Adjusted filtrate pressure = 6.2 psi - 1.7 psi = 4.5 psi
- Manual TMP = (8.3 psi + 7.6 psi)/2 - 4.5 psi = 3.5 psi
- Manual TMP, 3.5 psi, is significantly different than the recorded TMP, 2.1 psi.
- There appears to be an issue with the TMPs calculated and recorded by the control system. Contact the membrane vendor for clarification of how TMPs are being calculated.

TMP must be calculated at least once per day for each membrane unit. Typically, the average of all the TMPs values calculated during the day when a membrane unit was filtering water is reported to TCEQ. Make sure that average daily TMPs do not include data collected when a membrane unit was not filtering water, for example, during backwashes.

2. Failure to provide continuous turbidity monitoring

Continuous, online turbidimeters must be installed in all surface water and GUI treatment plants. Online, continuous turbidimeters must be installed on the effluent of each individual membrane unit (train, rack, skid, etc.) that is used for pathogen removal credit. For membrane filtration, “continuous” monitoring means each individual membrane unit’s filtrate turbidity must be monitored and recorded by the membrane control system or SCADA system at least once every 5 minutes when the filter is sending filtrate to the clearwell. If the plant operators want to use the turbidity data recorded by the online turbidimeter controllers as a backup in case of data loss in the membrane control system or SCADA system, the controllers must record turbidity data at no more than 5 minute intervals.

As of September 2020, the TCEQ had approved four online turbidimeter models for measurement of the typically low turbidity produced by individual membrane units that receive pathogen removal credit:

- Hach Filter Trak FT660
- Hach TU5400sc
- Lovibond PTV 2000
- Lovibond PTV 6000

Check the TCEQ website at <https://www.tceq.texas.gov/drinkingwater/trot/membrane-challenge-studies> for potential updates to the approved turbidimeter models. If your plant is using an unapproved turbidimeter model to measure the turbidity of individual membrane units, you must replace the turbidimeter with an approved model.

3. Improper monitoring of combined filter effluent (CFE) turbidity

The TCEQ often finds that CFE turbidity is monitored and recorded at incorrect times, particularly at PWSs that serve populations of 500 or more. If your PWS serves a population of less than 500, you are required to monitor and record the combined filter

effluent turbidity at least once each day the plant is in operation. PWSs that serve more than 500 persons must follow these requirements:

- You must take regular four-hour readings whenever the plant is in operation.
- You may, for example, take these readings at 2 a.m., 6 a.m., 10 a.m., 2 p.m., 6 p.m., and 10 p.m. Use the same schedule each day.
- Note that the TCEQ sets six standard four-hour periods each day: NTU1 is midnight to 4 a.m.; NTU2 is 4 a.m. to 8 a.m.; NTU3 is 8 a.m. to noon; NTU4 is noon to 4 p.m.; NTU5 is 4 p.m. to 8 p.m.; and NTU6 is 8 p.m. to midnight. Readings must be taken to represent each of the TCEQ's four-hour reporting periods when the plant is producing water for any portion of the time.
- You do not monitor and record a CFE turbidity value if your plant does not treat water during any portion of a standard four-hour period. Enter <X> for the four-hour period in the SWMOR.
- You must monitor and record a CFE turbidity value if your plant produces water for only a portion of a standard four-hour period, even if it is not at your normally scheduled time. You cannot report a CFE turbidity value collected when no filters were in operation.
- Please refer to the TCEQ's Regulatory Guidance document, RG-211, Chapter 3 for detailed CFE turbidity monitoring instructions.

Please note that if you allow your plant to run without an operator present, an online CFE turbidimeter must be installed and monitored by the plant control systems. The operators must report CFE turbidity readings recorded when the plant was unmanned. The plant control systems must be programmed to trigger alarms and plant shutdowns using the online CFE turbidimeter readings.

In a low-pressure membrane plant the CFE turbidity samples for the membrane filters must be collected at a point where only low-pressure membrane filtrate exists and no other removal processes have impacted the turbidity of the samples. For example, you should not mix filtered water from conventional filters with the membrane filtrate prior to the CFE sampling point unless you have written authorization from the TCEQ specifically allowing this practice. If reverse osmosis membrane filters are located downstream of the low-pressure membrane filters, you must collect the CFE turbidity samples upstream of the reverse osmosis membranes.

4. Disinfectant monitoring in unapproved locations

Collecting disinfectant residual data at locations other than those in the approved CT Study can invalidate the CT calculations in the SWMOR. To be clear, you may collect disinfectant residual data anywhere in the plant for process management purposes. However, you must collect disinfectant residual data that you intend to report in the SWMOR at the monitoring locations in the approved CT Study. If you need to relocate a disinfectant monitoring location, contact the TCEQ's Technical Review and Oversight Team at 512-239-4691 to discuss revising your CT Study and updating your SWMOR.

5. Missing volume and flow rate measurement meters

Every treatment plant must have volumetric meters to record how much raw water enters the treatment plant and how much water is pumped to the distribution system. These two volumes must be monitored and recorded daily. Some operators assume that the daily amount of raw water that enters a plant must equal the amount of water that is pumped out of the plant. As a result, they only monitor and record the values from one meter. Every plant has some kind of storage tank in which the stored volume of water can fluctuate. When the volume of stored water changes from one day to the next,

the volumes of raw water entering the plant and water pumped to distribution cannot be equal.

Every surface water or GUI treatment plant must have some sort of measuring device(s) to determine instantaneous flow rates through the disinfection zones in the plant. Some operators incorrectly record the volume of water treated during the day as an instantaneous flow rate. To illustrate why this is incorrect, consider the following example:

- 1 million gallons of raw water is sent to a plant on a particular day. The operator records the plant flow rate as 1 million gallons per day (1 MGD).
- The plant cycled on and off during the day. The plant actually treated water for 6 hours during the 24 hour period.
- Calculate the actual flow rate assuming the plant treated water at the same flow rate when it was on:

$$\frac{1 \text{ million gallons}}{6 \text{ hours}} \times \frac{24 \text{ hours}}{1 \text{ day}} = \frac{4 \text{ million gallons}}{1 \text{ day}} = 4 \text{ MGD}$$

In other words, if the plant had run continuously for 24 hours it would have treated 4 million gallons. The operator underreported the instantaneous flow rate by 400% in this example. This error would cause the SWMOR to calculate an inactivation ratio that is 4 times higher than the actual value.

In low-pressure membrane plants there must be some type of metering equipment to determine the instantaneous flow rates through each membrane unit and how much filtered water each individual membrane unit produces each day. In many cases the data from a flow rate meter is “totalized” into a daily volume by multiplying the instantaneous flow rates by a small interval of time to calculate the volume during that interval of time and then totaling all the small volumes of water for an entire day.

6. Assumption of equal flow splits to parallel treatment units

Another common flow rate monitoring issue involves the assumption of equal flow splits to parallel treatment units. For example, the treated water flow stream in a plant could be split to two clearwells/ground storage tanks that operate in parallel. If the piping to the two clearwells is not identical – length of pipe, diameter of pipe, number of pipe bends, valves, pipe outlets into the tanks, etc. – the flow rates to the two tanks may/will not be equal. A flow meter should be installed on the pipes to each tank if those tanks are used for inactivation credit. If your CT Study is set up to assume equal flow splits to parallel units and there is no reasonable way to guarantee that the flows are split equally, the CT Study should be revised and some means to measure the actual flow rate through each unit should be employed, like a flow meter.

Flows that are split to treatment units through a common trough are often assumed to be equal. However, small differences in the velocity of water and height of water within a trough can significantly impact the loading rate to individual basins. This is most pronounced when there are 3 or more parallel basins. Flow rates through sedimentation basins can be estimated from the height of water over the weirs or orifices at the end of the basins. Flow meters and flow rate controllers are commonly installed on each individual filter unit.

7. Improperly calibrated measurement devices

The TCEQ sets rules for both how often and by what method different measurement and testing devices must be calibrated and verified. Here is an abbreviated list of common measurement devices found in surface water and GUI treatment plants with calibration/verification requirements taken from 30 TAC §290.46(s):

a. Flow-measuring devices and rate-of-flow controllers (includes volumetric meters)

The devices must be calibrated at least once every 12 months. In membrane plants that use an air flow rate DIT, this calibration requirement applies to the air flow meters used in the DITs.

One difference: Well meters must be calibrated at least once every 3 years.

b. pH meters

Benchtop (includes handheld) pH meters must be calibrated according to manufacturer specifications at least once each day. Calibration must be checked with at least one pH buffer each time a series of samples is run. If the pH meter reading is not within 0.1 pH units of the expected buffer value, the meter should be recalibrated.

Online pH meters must be calibrated according to manufacturer specifications at least once every 30 days. Online pH meters must be verified with a primary standard or against a properly calibrated benchtop pH meter at least once per week. If the online pH meter reading is not within 0.1 pH units of the expected value, the online meter should be recalibrated.

Maintenance Notes: Many pH meters that TCEQ observes at treatment plants use a gel-filled, bulb type electrode. These probes are often inaccurate because of poor maintenance practices. To maintain these pH probes in good condition, they should be stored, preferably, in pH storage solution. Tap water is not a good substitute for pH storage solution but distilled or deionized water is a much worse choice for storage. These probes should not be stored dry.

c. Turbidimeters

Benchtop (includes handheld) turbidimeters must be calibrated with primary standards at least once every 90 days. The calibration of benchtop turbidimeters must be checked with secondary (verification) standards each time a series of samples is tested. The EPA-approved turbidity analysis method (Method 180.1) specifies that the turbidimeter should read within +/- 10% of the expected secondary standard value or the turbidimeter should be recalibrated.

Online, continuous turbidimeters must be calibrated with primary standards at least once every 90 days. The calibration of online turbidimeters must be verified at least once per week with a primary standard, secondary standard, with a manufacturer's proprietary calibration confirmation device, or by comparing the results with a properly calibrated benchtop turbidimeter. The online turbidimeter should be recalibrated if it does not read within +/- 10% of the expected value for turbidity greater than or equal to 1.0 NTU or if it is not within +/- 0.1 NTU of the expected value for turbidity less than 1.0 NTU.

d. Chemical disinfectant residual analyzers

These requirements apply to free chlorine and total chlorine analyzers:

- The accuracy of manual (handheld and benchtop) disinfectant residual analyzers must be verified at least once every 90 days using chlorine solutions of known concentration.
- The accuracy of online, continuous disinfectant residual analyzers must be checked at least once every 7 days with a chlorine solution of known concentration or by comparing the results with a manual analyzer.
- If a disinfectant residual analyzer produces a result that is not within +/- 15% of the expected value, the cause of the discrepancy must be determined and corrected and, if necessary, the instrument must be

recalibrated. Generally, recalibration of chlorine analyzers must be performed by the manufacturer.

e. Chloramine effectiveness and nitrification analyzers

These requirements apply to equipment used for the analysis of monochloramine, free ammonia, nitrate, and nitrite. Analyzers must be verified in accordance with manufacturer's specifications at least once every 90 days. This will often include testing the analyzers with standards of known concentration.

f. Pressure transducers for measuring pressures across membrane units

Pressure transducers (also called pressure transmitters) are pressure measuring devices that produce an electrical output that can be read and recorded by a control system. In membrane plants, pressure transducers are used to measure pressures during DITs and transmembrane pressure (TMP) while the membranes are filtering water. While it is important that the pressure transducers measure pressure accurately, it is more important that the pressure transducers have the resolution to detect small changes in pressure, particularly during pressure-based DITs. Like any other measurement device, the accuracy and resolution of a pressure transducer should be verified occasionally and the device should be recalibrated or replaced, if necessary, so that the pressure transducer can perform its vital function in a membrane plant. The plant's membrane exception letter, not 30 TAC §290.46(s), will specify verification requirements for pressure transducers. In general, the exception letters require the pressure transducers used to perform DITs to be calibrated once every 12 months. Other calibration frequencies may be allowed if supported by manufacture's documentation.

8. Improper monitoring of disinfectant residuals entering distribution system

The disinfectant residual of water entering the distribution system must be measured every day the plant pumps water to distribution. The sample point must be at or after the end of the last disinfection zone in (or outside) the plant, as defined by the plant's approved CT Study, and be representative of water entering the distribution system.

For PWSs that serve a population of 3,300 or less, grab samples may be collected at regular intervals throughout the daily periods of operation according to this schedule:

- Population of 500 or fewer - 1 sample per day
- Population of 501 to 1,000 - 2 samples per day
- Population of 1,001 to 2,500 - 3 samples per day
- Population of 2,501 to 3,300 - 4 samples per day

PWSs that serve a population of more than 3,300 must be equipped with an online disinfectant residual analyzer that samples the water entering the distribution system at least once every 30 minutes.

9. Raw water analyses

Raw water sent to surface water and GUI treatment plants must be monitored for turbidity and alkalinity at least once each day while the plant is in operation. These samples are typically collected before any treatment occurs, including disinfectant chemical injection, and must be collected after any recycled water is injected back into the treatment stream. You may get written approval from the TCEQ to collect the raw water samples after disinfection if you have multiple sources and you do not have and cannot install a sample tap at a location where the raw water from all of your water sources combines before treatment, contact the TCEQ's Drinking Water Quality Team at 512-239-4691 for instructions.

10. Incorrect collection times for disinfection performance data

The TCEQ requires that the data for inactivation calculations be collected when the treatment plant is operating at its peak flow rate (technically, the peak hourly flow rate) on any given day. Here we are talking about the disinfection process data (also known as CT data): disinfectant residual concentrations, flow rates, temperature, and pH in each disinfection zone in the plant. Operators frequently collect this data at the same time each day without regard to flow rate through the plant. The following examples illustrate acceptable times to collect disinfection performance data:

- If you collect the disinfection process data at your normal time and then the flow rate through the plant increases later in the day, you must recollect all of the disinfection process data.
- If you collect the disinfection process data and the plant flow rate stays the same throughout the day or drops, you are not required to recollect the data.
- If your plant auto cycles and can operate at the peak daily flow rate when an operator is not present, the disinfection process data must be monitored and recorded automatically so that the operator can retrieve the data. This means the disinfectant residual, flow rate, temperature and pH must be monitored online at the end of each disinfection zone.

You can limit the flow rate through an auto cycling plant when no operator is present so it cannot exceed the flow rate when the disinfection process data was collected. This is an acceptable way to avoid the requirement to have online disinfectant residual, flow rate, temperature, and pH equipment for each disinfection zone.

Another related issue to clarify is that a set of disinfection data must come from the same moment in time. For example, if you collect a sample at 8:00 AM and measure disinfectant residual, pH, and temperature, you must use the plant flow rate at the same time, 8:00 AM, to complete this set of data. Do not use the flow rate from a different time.

11. Improperly spanned online turbidimeters

The TCEQ commonly finds online, continuous turbidimeters set up to record a span of turbidity levels that stops below regulatory trigger or compliance levels. For example, at a specific turbidity monitoring point, a boil water notice is triggered when the turbidity exceeds 5.0 NTU. However, the turbidimeter and/or Supervisory Control and Data Acquisition (SCADA) system is spanned only to record turbidities between 0.0 NTU and 1.0 NTU. If the actual turbidity reaches 10 NTU, the recorded value would be 1.0 NTU. Turbidimeters and SCADA systems must be spanned to measure and record turbidities up to at least 110% of the highest applicable trigger or compliance levels at a specific monitoring location.

Trigger and compliance levels vary by the monitoring location of the turbidimeter and the type of filters. Here is a summary of trigger levels, compliance levels, and online turbidimeter spanning requirements for filters that are used for pathogen removal credit:

- Membrane filters
 - Individual membrane units (skids, racks, etc.)
 - Trigger level: 0.15 NTU (154 mNTU rounds to 150 mNTU)
 - Span the turbidimeter and SCADA system to read and record accurately from 0.000 NTU (0 mNTU) to at least 0.165 NTU (165 mNTU).

- Combined filter effluent (CFE)
 - Compliance level: 1.0 NTU (1.04 NTU rounds to 1.0 NTU)
 - Span the turbidimeter and SCADA system to read and record accurately from 0.0 NTU to at least 1.1 NTU.
- Conventional, bag, and cartridge filters
 - Individual filters and filter assemblies
 - Trigger levels: 1.0 NTU and 2.0 NTU
 - Span the turbidimeter and SCADA system to read and record accurately from 0.0 to at least 2.2 NTU.
 - Combined filter effluent (CFE)
 - Compliance levels: 0.3 NTU, 1.0 NTU, 5.0 NTU
 - Span the turbidimeter and SCADA system to read and record accurately from 0.0 to at least 5.5 NTU.

12. Online turbidimeter signal scaling issues.

Among the many features of online turbidimeter controllers, one of the most important is to process the measurements from the turbidimeter and transmit a signal that corresponds to the measured turbidity level to the plant's control systems. TCEQ mostly encounters turbidimeter controllers that transmit analog 4 - 20 mA signals that correspond to the range of turbidities the turbidimeter is programmed to transmit. We'll limit this discussion to analog signals. (Online turbidimeters with a digital signal output are also programmed to transmit a certain span of turbidities but the details are different.) A 4 mA signal should correspond to 0.00 NTU or 0 mNTU. A 20 mA signal corresponds to whatever maximum turbidity the turbidimeter controller has been spanned to transmit as discussed in Section C.11. For example, the 4 - 20 mA signal from a turbidimeter controller is programmed to correspond to 0 - 1,000 mNTU. On this linear scale, a 12 mA signal from the turbidimeter controller would correspond to 500 mNTU. (12 mA is halfway between 4 and 20 mA; 500 mNTU is halfway between 0 and 1,000 mNTU.)

The plant's control systems, for example, the membrane manufacturer's control system and a separate plant SCADA system, are also programmed to interpret the signal coming from the turbidimeter controller. Let's say, for example, the 4 - 20 mA signal from the turbidimeter controller corresponds to a span of 0 - 5,500 mNTU that was programmed into the controller. If one of the plant's control systems is programmed to interpret a 4 mA signal as 0 mNTU and a 20 mA signal as 1,000 mNTU, the values recorded in the control system won't match the measurements at the online turbidimeter. In fact, the control system's recorded values will be a 1,000/5,500 fraction, or 18%, of the online turbidimeter's measurements. The plant's control systems must be programmed to interpret the scale of the 4 - 20 mA signal the same way that the turbidimeter controller is programmed to transmit the signal.

If you adjust the span of an online turbidimeter and its controller, you must simultaneously adjust the programming of the control systems that receive the signal so that they continue to interpret the scaling of the 4 - 20 mA signal correctly.

13. Instantaneous readings from other online instruments

Besides the online turbidimeters, there are a number of other online instruments that must be present in membrane treatment plant to measure and transmit data to the plant control systems - pressure transducers for transmembrane pressure (TMP) and DIT pressure decay rates, flow meters for instantaneous flow rates and water production volumes, and a temperature probe for normalized filter flux rates and

normalized specific flux. Most membrane plants are also required to have an online disinfectant residual analyzer to measure free chlorine or total chlorine levels leaving the plant to distribution. Like the online turbidimeters, these online instruments transmit a signal, typically an analog 4 - 20 mA signal, that the control systems must be programmed to interpret correctly. The 4 - 20 mA signal from an online instrument corresponds to a span of the parameter the instrument measures, for example, 0 - 45 psi for a pressure transducer. Unlike the online turbidimeters, the span is often hard-wired into these other online device and cannot be adjusted at the plant. In any case, if the control system isn't programmed to interpret the signals from these devices correctly, the values recorded in the control system won't match the values measured by the devices.

Many of these online devices do not have a display, a user interface, or the ability to send test signals to the plant's control systems. Operators may be limited to comparing the instantaneous values recorded by the control systems to manually measured values of the same parameter as a check of functionality. To fully check that the devices are working properly and the control systems are programmed to interpret the signals correctly, technicians must be hired who specialize in verifying and calibrating these devices.

- For all online instruments

Attempt to collect a manual reading of whatever parameter is measured by the online device to check that the online device is transmitting realistic data to the control systems. (This is not necessarily a verification of the absolute accuracy of the online device but simply a check that the online device is functioning.) Some unit conversion may be necessary.

- For online pressure transducers, temporarily install another pressure gauge near the pressure transducer and compare the instantaneous readings on the temporary pressure gauge to what is being displayed by the pressure transducer (if it has a display) and what is simultaneously recorded in the plant's control systems.
- For online temperature probes, measure the temperature of a water sample collected near the temperature probe.
- For online disinfectant residual analyzers: If you are reporting compliance data from this device, you are already required to verify the readings of online disinfectant residual analyzers; however, take this a step further and check that the simultaneous values recorded in the control systems are close to the verification measurement.
- For online flow meters: It usually isn't possible to install a temporary flow meter to compare against the online flow meter; however, the online flow meter must be calibrated annually, so we'll count that as the check of functionality for this device. If you haven't had the online flow meter calibrated within the last 12 months, do so.

If your manual measurements are not close to the simultaneous values recorded by the plant's control systems, hire a technician to troubleshoot the online device (in other words, verify its accuracy and functionality) and the communication between the device and the plant's control systems.

If more than one control system records the data from an online instrument, compare the simultaneous values recorded by all of the control systems. It is possible for there to be communication issues between the device and only one of the control systems or between the control systems.

- Online instruments that display an instantaneous measurement

Write down the simultaneous readings displayed by the device and recorded by the plant's control systems. Verify that these values are the same. If they are not the same, hire a technician who specializes in verifying and calibrating online devices to troubleshoot the device and the control systems.

You probably need two people to make this test work, particularly if the measurements fluctuate frequently at the device. One will read the display at the online device out in the plant. The other person will watch the corresponding values in the control system interfaces.

Make note of the units displayed by the online instrument. The displayed units may be different than the units recorded by the control systems. For example, an online pressure gauge might display pressure in units of feet of water while the control system records pressure in units of psi. Some unit conversion may be necessary to compare the values.

Don't assume that the internal clocks within the control systems are synchronized with your phone or watch. It is more reliable for the two people running this test to compare values in "real time" over the phone or by yelling to each other to match displayed readings with recorded readings.

If you have the ability to control the readings measured by the online device, for example, pressure and flow rate, try to make readings both near the lower end and upper end of the device's span to compare with the values recorded by the control systems.

- Online instruments that have a user interface

Within the user interface try to determine what span of measured values is transmitted by the device. For example, an online disinfectant residual analyzer may be programmed to transmit a measured residual of 0.00 mg/L as a 4 mA signal and a measured residual of 5.5 mg/L as a 20 mA signal.

If the device has the ability to transmit test signals to the control system, send test signals corresponding to the lowest and highest levels in the instrument's span and make note of the values that are recorded at the same time in the plant's control systems. If the values recorded by the control systems don't match the expected values from the test signals, hire a technician to troubleshoot the online device and the communication between the device and the control systems.

14. Automatic alarms and shutdowns for low pressure membrane filters

With respect to low pressure membrane filters, the following three conditions must never be allowed to occur:

- Condition 1: A membrane unit that has failed a DIT based on the TCEQ-approved DIT parameters or a membrane unit that has been out of service sends filtered water to distribution before it has passed a subsequent DIT.
- Condition 2: A membrane unit that has experienced two consecutive, continuous IFE turbidity readings above 154 mNTU sends filtered water to distribution before it has passed a DIT. (For membrane filters the TCEQ defines continuous as 5-minute IFE turbidity readings.)
- Condition 3: The CFE turbidity exceeds 1.0 NTU.

These conditions indicate that the membrane filters may not be functioning properly and could be allowing *Giardia lamblia* cysts, *Cryptosporidium parvum* oocysts, and other pathogens to reach the customers. These conditions represent a potentially

significant threat to public health Accordingly, monitoring or treatment technique violations are issued when these conditions occur.

Operators rely on the membrane plant's automatic shutdown controls to avoid these conditions. Membrane plants are highly automated and they often run when no operators are present. The TCEQ rules require automatic shutdowns and alarms when a plant is unmanned. Due to the nature of the membrane rules, shutdowns and alarms are also used when the plant has staff onsite. For example, it could be very difficult for an operator to manually shut down a membrane unit in time to avoid a violation after an IFE turbidity reading above 154 mNTU occurs.

The automatic settings in the plant's control systems will avoid these conditions if they have been programmed according to the requirements in the TCEQ rules and site-specific approval letters and the control systems are receiving valid online data from the membrane filters. We stop short of saying that the plant's control systems will always prevent these conditions from occurring because alarm and shutdown settings can be changed in the control system, purposefully or inadvertently.

- DIT considerations to avoid Condition 1

If DITs are allowed to be scheduled and run automatically by the membrane control system, it is critical that the control system use the TCEQ-approved DIT parameters as pass/fail criteria:

- Upper control limit (UCL) - the maximum allowed pressure decay rate or the maximum allowed airflow rate during a DIT.
- P_{test} - minimum test pressure to detect a 3 μm defect. The test pressure must remain above this minimum pressure during the DIT (applies to both pressure decay rate DITs and airflow rate DITs).

If your plant's membrane control system is using some other criteria to determine if a DIT passes or fails, you risk the control system categorizing a DIT as passed and placing the membrane unit back into production when it actually failed based on the TCEQ-approved DIT parameters. Here are some unapproved DIT pass/fail criteria that the TCEQ encounters:

- The control system uses the membrane manufacturer's proprietary log removal value (LRV, sometimes called log removal credit, LRC) calculations. The TCEQ does not recognize or approve LRV calculations for DITs.
- The control system uses total pressure drop, not pressure decay rate, during a DIT.

If the membrane control system uses unapproved criteria for the DITs, you shouldn't allow automatic DITs to occur. Instead, an operator should manually trigger each DIT, compare the results of the DIT against the TCEQ-approved parameters, and manually place the membrane unit back into production when the operator is certain that the DIT passed. Continue performing manual DITs until you update the membrane control system to use TCEQ-approved DIT parameters.

Additionally, there are two other situations where issues can occur during a DIT. The first is when the control system stops the DIT before it even begins collecting pressure data. For example, the starting test pressure fails to stabilize within a programmed amount of time and the DIT aborts before the pressure at time zero is collected. If an additional test was not performed on the same day, no DIT was performed on the unit and ND (no data) must be entered on the SWMOR-ALT in the DIT fields. This may result in violations.

Secondly, if the DIT begins and collects the first pressure reading, the test is considered valid and the upper control limit must be calculated no matter when the DIT stops. Some control systems are programmed to stop a test when the pressure in the test drops below a specific threshold. Some control systems take the UCL (psi/min) and multiply it by the duration of the test (in minutes) to find the total pressure drop allowed during a DIT for the test to pass. If the total pressure drop surpasses this calculated number, no matter when it occurs, the control system will stop the test and state the test failed. This is correct, the test is valid, and the unit failed. The unit must be kept out of service until it can be fixed, and the unit passes a subsequent DIT. The control system is stopping a test when it fails to save the operators time, but the test, even though stopped early, is still valid and shows a failure. Other vendors program the control system to stop a DIT if the test pressure approaches Ptest for the unit. This is also a valid test and the UCL must be calculated based on the total pressure drop and the total time of the test (in minutes). The UCL that is calculated would determine if the unit passed or failed.

If the membrane control system has properly recognized a failed DIT, it is imperative that the control system send an alarm to the operators and disable (shut down) the membrane unit so it cannot automatically go back into production. From that point on it is typically a manual process for the operators to troubleshoot what caused the failed DIT, run and pass a subsequent DIT, and then place the membrane unit back into its automated production cycles. Placing the membrane unit back in production before it has passed a subsequent DIT, whether as part of the automatic control sequences or through manual override, causes Condition 1 to occur and is endangering public health.

- IFE turbidity considerations to avoid Condition 2

How to avoid Condition 2:

- A membrane unit experiences two consecutive, 5-minute IFE turbidity readings > 154 mNTU while producing filtered water.
- The membrane unit is shut down immediately after it experiences two consecutive, 5-minute IFE readings > 154 mNTU. (If your plant is manned continuously and does not have an automatic IFE turbidity shutdown, you must manually stop the membrane unit before it experiences three consecutive, continuous IFE turbidity readings > 154 mNTU.)
- The membrane unit is subjected to a DIT. (See DIT considerations to avoid Condition 1 above for more details.)
 - If the DIT passes, the membrane unit can be placed back into its automated production cycles.
 - If the DIT fails, the membrane unit is disabled and cannot return to production until it has passed a subsequent DIT.

The TCEQ requires plants to measure the membrane IFE turbidity continuously and record the turbidity level every 5 minutes. Membrane control systems can record turbidity readings at much smaller time intervals, on the order of seconds, so the recording interval may be set differently within your control system. The TCEQ requires your membrane plant to generate a record of 5-minute IFE turbidity readings and to determine compliance with IFE turbidity requirements from that 5-minute record. Your plant may meet Condition 2 if the membrane control system does not use this same 5-minute IFE turbidity record to trigger shutdowns.

Membrane manufacturers may take different approaches to IFE turbidity shutdowns depending on how their control systems are set up. If the membrane

control system does not base IFE turbidity shutdown controls on turbidity readings at the standard 5-minute intervals, it won't comply with TCEQ's requirements for turbidity shutdowns; however, the turbidity shutdown requirements could be more restrictive than the TCEQ requirements, which is acceptable. We will categorize some typical turbidity shutdown approaches as compliant, more restrictive than TCEQ requirements, and noncompliant:

- Compliant

The membrane control system's shutdowns are triggered by the same set of 5-minute IFE turbidity readings that are recorded and used for reporting to the TCEQ. These 5-minute readings are recorded at the same standard times each day, for example, at 00:00 (midnight), 00:05, 00:10, ..., 23:45, 23:50, and 23:55 and the control system can distinguish between the values recorded when the unit was filtering water from values recorded at other times.

Here is an example of a compliant IFE turbidity shutdown sequence. While a membrane unit is producing filtered water, the IFE turbidity readings at 15:20 and 15:25 exceed 154 mNTU. The membrane control system shuts down the membrane unit so that it cannot continue producing filtered water at 15:30. The membrane unit is subjected to and passes a DIT before it is allowed to continue producing water.

- More restrictive than TCEQ requirements

A membrane control system that triggers an IFE turbidity shutdown after a single instantaneous reading above 154 mNTU is more restrictive than the TCEQ requirements. (At some membrane plants it is difficult or impossible to avoid short duration turbidity spikes above 154 mNTU, for example, when a membrane unit starts filtering water after a chemical clean has occurred, and an instantaneous IFE turbidity shutdown would not be workable.) Even though this instantaneous turbidity shutdown is more restrictive, the membrane unit must undergo and pass a DIT before it is returned to service.

- Noncompliant

When an IFE turbidity above 154 mNTU has been detected, any automatic turbidity shutdown that is not immediately followed by a DIT on the membrane unit is a noncompliant control sequence and violates the TCEQ's IFE turbidity requirements. For example, the membrane control system detects a turbidity of 210 mNTU, triggers a turbidity shut down, puts the unit through a backwash or air scrub, and then returns the unit to production. As a general matter, any turbidity shutdown that avoids recording two consecutive, 5-minute IFE turbidity readings above 154 mNTU is noncompliant if it is not immediately followed by a DIT on the membrane unit. Avoiding the requirement to report confirmed turbidity readings above 154 mNTU is not a defense for not conducting a DIT after a turbidity shutdown.

A membrane control system that uses a timer to trigger an IFE turbidity shutdown won't be compliant 100% of the time. If the turbidity drops to 154 mNTU or less before the timer completes and then the timer resets, there is a possibility that two consecutive, 5-minute turbidity readings could be recorded without triggering a DIT. For example:

- 08:19 - the instantaneous turbidity reading is 198 mNTU and the turbidity shutdown timer starts.

- 08:20 - the turbidity reading is 234 mNTU and this value is recorded in the 5-minute IFE turbidity record.
- 08:21 - the turbidity drops to 130 mNTU and the turbidity shutdown timer stops.
- 08:22 to 08:23 - the turbidity remains below 154 mNTU.
- 08:24 - the turbidity rises to 173 mNTU and the turbidity shutdown timer starts.
- 08:25 - the turbidity reading is 206 mNTU and this value is recorded in the 5-minute IFE turbidity record.
- 08:26 - the turbidity drops to 118 mNTU and the turbidity shutdown timer stops.

The next day when the operators are compiling the reports for the previous day, they notice that there are consecutive readings above 154 mNTU at 08:20 and 08:25 in the record; however, the membrane unit continued to produce filtered water. Condition 2 was met. Even if the timer doesn't reset when the turbidity drops to 154 mNTU, no timer of any duration can always prevent two consecutive, 5-minute turbidity readings from being recorded without a corresponding DIT being triggered. A timer can fail when turbidity drops to 154 mNTU or less and rises again above 154 mNTU between 5-minute readings because this could appear to be two separate turbidity events to the membrane control system but is one continuous event in the 5-minute IFE turbidity record. The TCEQ requires you to use the 5-minute IFE turbidity record for compliance, therefore you shouldn't use any timed turbidity shutdown setting that isn't based on the 5-minute record.

As you go through the corresponding items in the Low Pressure Membrane Plant Checklist, you should be able to tell which IFE turbidity shutdown approach your membrane control system takes. We highly recommend that you adopt the Compliant IFE turbidity shutdown approach to avoid Condition 2.

- CFE turbidity control considerations to avoid Condition 3

In a low-pressure membrane plant a CFE turbidity reading above 1.0 NTU, for example, 1.05 NTU (1,050 mNTU), is an acute treatment technique violation that requires public notice and a boil water notice within 24 hours. The concept of confirmed, consecutive readings does not apply to CFE turbidity measurements.

Although it may appear that properly configured IFE turbidity shutdown controls will always prevent the CFE turbidity from exceeding 1.0 NTU, there are circumstances when the CFE turbidity can be much higher than the IFE turbidities of the contributing membrane units. For example, floc can form after the membrane filters as a result of coagulant and pH control issues. Also keep in mind that properly configured IFE turbidity shutdown controls are based on two consecutive, 5-minute turbidity readings. IFE turbidities could spike well above 154 mNTU for almost 10 minutes before individual membrane units are shut down.

Most low pressure membrane plants use an online turbidimeter to record and report CFE turbidity so that the plant can continue to produce water when no operators are present. The best defense against a rapid, uncontrolled CFE turbidity spike is an instantaneous CFE turbidity shutdown that occurs well below 1.0 NTU. For example, if your normal CFE turbidity readings are around 0.02 NTU (20 mNTU), you could trigger a CFE turbidity shutdown at 0.1 NTU (100 mNTU) and keep a large buffer between your normal CFE readings and the 1.0

NTU level. You should not trigger a CFE turbidity shutdown at or near 1.0 NTU because a turbidity spike could easily jump from below 1.0 NTU to 1.05 NTU between two instantaneous CFE readings.

You MUST specify the TCEQ-approved, site-specific conditions that should be used to operate your membranes to your membrane supplier. If you do not specify the requirements, the membrane manufacturer may install a control system that does not meet your needs. You may find it difficult and/or expensive to operate around or reprogram a membrane control system that was not initially set up in accordance with TCEQ requirements.

15. Other alarms and shutdowns for auto cycling facilities

Besides the automatic alarm and shutdown capabilities that are required or recommended specifically for and triggered directly by the membrane filters, there are other alarm and shutdown features that must be included with a surface water or GUI treatment plant that auto cycles on and off when no operator is present. At a minimum there must be alarms and a plant shutdown that are triggered by an online disinfectant residual analyzer that monitors the water leaving the plant. In more sophisticated plants, alarms and shutdowns can be triggered by any number of conditions in the plant or distribution system, including tank water levels, pump faults, chemical pump faults, etc. Alarm levels and shutdown points should be set to prevent the plant from producing water that does not meet regulatory requirements, for example, low disinfectant residuals entering the distribution system.

16. Lack of continuous monitoring equipment for auto cycling facilities

If your plant automatically cycles off and on, the TCEQ considers the plant to be in continuous operation. No matter what population your PWS serves, these plants must be equipped with an online CFE turbidimeter, continuous disinfectant residual analyzer, and data recording system unless an operator is always present at the plant. This equipment will allow the operator to determine CFE turbidity values and disinfectant residuals leaving the plant at times when the plant is unmanned and to notify the operator and shut down the plant if turbidity levels rise above or disinfectant residuals drop below acceptable levels. (See C.15.)

17. Free chlorine residual measurement

The most common analysis methods for free chlorine use DPD reagents. DPD analysis methods are subject to interference from other disinfectants, oxidants, and metals. Monochloramine and manganese are the most common interferences that TCEQ finds in Texas. The concentrations of the interfering agents have a direct impact on the level of interference that they cause during a DPD method analysis.

We will consider two hypothetical cases in which manganese interference is causing 0.2 mg/L of false positive response during a free chlorine analysis using a DPD method. In the first case the free chlorine residual is actually 2.5 mg/L and the result of the analysis is 2.7 mg/L because of the interference. In the second case, the actual free chlorine residual is 0.1 mg/L and the result of the free chlorine analysis is 0.3 mg/L because of the manganese interference.

In the first case, the absolute error in the analysis, 0.2 mg/L, represents a $0.2/2.5 = 0.08 = 8\%$ relative error. In the second case, the absolute error represents a $0.2/0.1 = 2 = 200\%$ relative error. The significance of the absolute error increases as the actual free chlorine residual gets closer to zero.

TCEQ is most concerned about the accuracy of free chlorine residuals reported below 0.5 mg/L that have been measured with a DPD method because the errors due to interferences can become extremely significant. These errors have tremendous implications for free chlorine residuals that are reported for disinfection credit in plants that operate under the requirements of a TCEQ-approved CT Study. For example, if a 0.3

mg/L free chlorine residual is reported through a disinfection zone in an SWMOR and the actual free chlorine residual is 0.1 mg/L, the SWMOR will give the plant 200% more disinfection credit in that zone than it deserves.

The required accuracy for free chlorine analyses that are reported to TCEQ for microbial inactivation purposes is +/- 0.1 mg/L. There are several alternative analytical methods that are approved by the EPA and TCEQ, are not subject to the same interferences as the DPD method, and can meet the required accuracy at free chlorine levels below 0.5 mg/L:

- Amperometric titration method
- Syringaldazine (FACTS) method
- Indophenol colorimetric method (Hach Method 10241)

If you are reporting free chlorine residuals through your plant for pathogen disinfection/inactivation credit (in other words, you report a free chlorine residual in one or more of the plant's disinfection zones on the SWMOR spreadsheet tab labeled "P.4&5-Disinfection Data") and DPD interferences are or could be present, it becomes much more likely that you cannot meet the analysis accuracy requirements using DPD reagents. More importantly, your plant may not be meeting minimum inactivation requirements which presents a risk to your customers. Use one of the other approved free chlorine analysis methods.

D. Common Reporting Issues

Daily treatment data from your surface water or GUI treatment plant are reported to the TCEQ on a monthly basis through a version of the SWMOR customized for your plant. We recommend that you obtain an up-to-date copy of the TCEQ's regulatory guidance document RG-211, Monthly Testing and Reporting at Surface Water Treatment Plants (2021 revision) for additional reporting instructions. Here are some common problems in the SWMORs.

1. Use of incorrect SWMOR spreadsheet

Plants that have any of the following innovative/alternate technologies should use the SWMOR-Alt, Form TCEQ-00102D along with the worksheets related to the specific technology:

- Bag & Cartridge Filtration
- Membrane Filtration
- Disinfection Using Chlorine Dioxide, Ozone, or UV
- Pre-filtration (such as bank filtration or a coagulated pre-sedimentation basin that is in addition to and upstream of coagulation, flocculation and sedimentation basins)
- Enhanced Individual Filter Effluent Turbidity
- Enhanced Combined Filter Effluent Turbidity
- Second Stage Filtration

Each alternate technology has a separate worksheet in the SWMOR-Alt which will be activated when the SWMOR-Alt is customized. The latest version of the spreadsheet can be downloaded at <https://www.tceq.texas.gov/drinkingwater/swmor/swmor/swmor-forms-and-instructions>.

2. Claiming unapproved treatment credit

The information used to customize the SWMOR spreadsheet should come from the TCEQ approval letters for the treatment plant: the CT Study letter, the letter(s) that approve the design of the plant, and any exception or direct integrity test (DIT) letters.

Plants should not claim credit for treatment which is not included in a TCEQ approval letter.

Please check your SWMOR-Alt form for these specific unapproved and inappropriately claimed treatment credits.

- **Pre-sedimentation basins.** This credit is NOT to be claimed if your membrane plant has a sedimentation basin before the membrane filters. You will receive pathogen removal credit for your pre-membrane-filter sedimentation basin if you entered the number of sedimentation basins into your SWMOR-Alt during customization. You will also see the credit on the LT2-summary page under pretreatment credits listed as “conventional sedimentation or clarification.”

Pre-sedimentation basin credit must only be claimed if you have an ADDITIONAL sedimentation basin before your conventional sedimentation basin AND you add a coagulant to that basin, monitor the turbidity of the influent, and effluent and show a 50% reduction in turbidity. As of October 2020, no plants have requested or received approval for “pre-sedimentation” pathogen removal credit. You can see if you are claiming this credit by looking at page 1 and on the LT2 summary pages. You must immediately reconfigure your SWMOR-Alt if you are claiming this pathogen removal credit.

- **Conventional Media Filtration.** A plant with only membrane filter units must NOT claim credit for media filters. During customization of the SWMOR-Alt, you must enter zero (0) for the number of conventional filters used at the plant. If the plant uses both conventional media filters and membrane filters, the LT2 summary pages must show the conventional filters on a different “Train” than the membrane filters. If you have customized the SWMOR-alt incorrectly you will see that you are receiving 6 log (or more) removal of *Cryptosporidium* on page 1 of the SWMOR and the LT2 Summary page will show the conventional and membrane filters on the same “Train”. You must immediately reconfigure your SWMOR-Alt to correct these settings.
- **Enhanced IFE or CFE turbidity.** This removal credit is ONLY allowed for conventional granular media filters. You can see if you are claiming this credit by looking at page 1 and on the LT2 summary pages. You must immediately reconfigure your SWMOR-Alt if you are claiming this pathogen removal credit for membrane filtration units.

3. Incorrect raw or treated water volumes

The raw water volume delivered to the plant and the volume of water pumped to distribution must be reported daily. Do not report readings from a single meter for both volumes. These are two independent measurements. See related discussion in Section C.5., Common Monitoring Issues, “Missing volume and flow rate measurement meters.”

4. Incorrect flow rates for disinfection/inactivation calculations

As described in Section C.5., Common Monitoring Issues, “Missing volume and flow rate measurement meters,” it is not unusual to see operators report the total amount of water produced during the day when they enter CT data on pages 4 & 5 of the SWMOR. When completing this part of the monthly report, enter the actual flow rate(s) of water that was occurring when the disinfection process data was collected.

5. Incorrect turbidity units for membrane filters

Treatment plants that use membranes for pathogen removal credit must report individual membrane rack/skid turbidity in units of milli-NTUs (mNTUs), not NTUs. If turbidity data is saved in your system with units of NTU, multiply the NTU value by 1,000 to convert it to a mNTU value before you enter the data on the Membrane pages in the SWMOR-Alt. For example:

1 NTU = 1,000 mNTU

0.012 NTU = 12 mNTU

You can easily identify if you are reporting in NTU instead of mNTU because all the turbidities for the membrane units will be shown a 0 or 1.

6. Failure to include the LT2-Summary page in SWMOR submittals

If your surface water or GUI treatment plant is required to use the SWMOR-Alt form because it uses an innovative/alternate technology like cartridge filters, membranes, UV, pre-filtration, enhanced filtration, or second stage filtration, an LT2-Summary worksheet will be generated in the SWMOR-Alt spreadsheets. You must complete the LT2-Summary worksheet and include it with your SWMOR-Alt submittal to TCEQ each month.

7. Incorrect reporting of disinfection process data

If you collect more than one set of CT data during the day, do not mix data from different times when you report the results on pages 4 & 5 of your SWMOR or SWMOR-Alt. For example, CT data (disinfectant residual, flow rate, pH, and temperature) is collected at 8:00 a.m. and 2:00 p.m. Enter both sets of data, one at a time, into the SWMOR and report the set of data that generates the lowest overall inactivation ratio. The TCEQ has created a spreadsheet that will allow simultaneous entry of up to six sets of CT data collected during a day to help identify which set of data should be reported in the SWMOR. You may request this spreadsheet by contacting the Texas Optimization Program at TOP@tceq.texas.gov.

8. Incorrect reporting of maximum individual filter unit effluent turbidity

Operators must report a turbidity value daily for the water produced by each individual filter unit (conventional filter basin, bag or cartridge filter assembly, membrane rack/skid/train) when they fill out the SWMOR. Usually, the operators must report the highest daily reading recorded from each filter unit. However, if the maximum turbidity reading for a particular filter exceeds one of the applicable trigger levels (1.0 NTU or 2.0 NTU for granular media filters and bag & cartridge filters, and 154 mNTU for membranes) the concept of “confirmed readings” kicks in:

- A confirmed reading is a reading above a filter unit’s trigger level that is preceded or followed by a second reading that also exceeds the trigger level.
- A reading is not confirmed if both the preceding and following measurement are below the trigger level.
- Only confirmed readings above a trigger level should be reported on the SWMOR.
- In the case of individual granular media filters, bag filters, and cartridge filter assemblies, turbidity readings must be recorded at 15 minute intervals. A confirmed reading is the higher of 2 consecutive, 15 minute readings above the trigger level.
- In the case of individual membrane filter units, turbidity readings must be recorded at 5 minute intervals. A confirmed reading is the higher of 2 consecutive 5 minute readings above the trigger level.
- If the control system is set up to avoid recording a second reading over the trigger level (for example, the control system sees a reading over the trigger, it shuts down the unit for 15 minutes, and puts the unit back in service without running a DIT), then the plant must report the single reading over the trigger.

Many operators are unfamiliar with the confirmed reading concept. A single, unconfirmed individual filter effluent turbidity reading above a trigger level should not be reported on the SWMOR. Additional details are available in RG-211. (Note: the

concept of confirmed readings does not apply to combined filter effluent turbidity samples.)

In a low-pressure membrane plant, you must use a daily 5-minute record of individual membrane unit filtrate turbidity to determine the maximum daily IFE turbidity reported on the membrane page of the SWMOR. You cannot use a report that includes data recorded at more than 5 minute intervals to report the maximum daily turbidity.

Operators are not allowed to exclude any turbidity spikes from the reported data, even if the operators attribute the spikes to air bubbles. As discussed in Section B.1.g., operators must investigate and fix the causes of recurring turbidity spikes.

9. Reporting CFE turbidity values collected at incorrect times.

Refer back to Section C.3. for a detailed explanation of CFE turbidity monitoring requirements. A common error that the TCEQ encounters is reporting CFE turbidity values that were recorded when none of the filters was operating. If the CFE turbidity is monitored by an online turbidimeter, it probably monitors turbidity when the filters are off. Whether the values are collected by an online turbidimeter or through grab samples, if the operators report the values from set times without checking to see if the filters were operating, some of those reported readings will be invalid.

10. Incorrect CIP reporting

Operators must keep a record of the CIPs that are conducted on each membrane unit. Ideally, the CIP record will include the date, start and stop times of the CIP, and the date and start time of the DIT that was passed before placing the membrane unit back in service. While a CIP is in progress, the membrane unit is out of service and does not produce filtered water.

The date on which a CIP completed is reported on the membrane page of the SWMOR. The SWMOR will check to see if a DIT was conducted on that day for compliance purposes. An audit of the plant's CIP and DIT records, including records in the control systems, is recommended to verify that no filtered water has been produced between a CIP and its subsequent DIT. Maintenance cleans should not be reported as CIPs.

11. Incorrect reporting of average daily Normalized Filter Flux

If the membrane control system or plant SCADA system records multiple values of Normalized Filter Flux each day (and most do), the average of those values should be reported each day in the SWMOR. It is incorrect to select one instantaneous value of Normalized Filter Flux for reporting if multiple values are available. Note that some control systems may call this the Temperature-Corrected Flux. See the RG-211 guidance document for additional instructions.

12. Incorrect reporting of average daily Transmembrane Pressure (TMP)

If the membrane control system or plant SCADA system records multiple values of TMP each day (and most do), the average of those values should be reported each day in the SWMOR. It is incorrect to select one instantaneous value of TMP for reporting if multiple values are available. See the RG-211 guidance document for additional instructions.

13. Incorrect reporting of multiple DITs on a membrane unit in a single day

If you conduct more than one DIT on a specific membrane unit during a day, for example, the membrane unit failed a DIT, the cause of the failure was repaired, and a subsequent DIT was conducted and passed, you must report the lowest DIT test pressure and the highest pressure decay rate from all of the DITs. For this particular reporting requirement, these reported data can come from the results of different DITs.

14. Incorrect customization of approved parameters in the SWMOR form

A plant's SWMOR form must be set up (customized) with the latest versions of site-specific parameters approved by the TCEQ for compliance determinations. In a low-pressure membrane plant that receives pathogen removal credit, there are typically three site-specific approval letters:

- DIT Values Letter

This letter sets the approved Ptest, Upper Control Limit (UCL), and Log Removal Credit (LRC) for DITs conducted on the plant's membrane units.

- CT Study Letter

This letter defines the disinfection zones in a plant, how disinfection/inactivation credit will be calculated in each zone, and the minimum inactivation requirements for *Giardia* and viruses.

- LT2 Bin Classification Letter

This letter sets the minimum treatment requirements for *Cryptosporidium* based on a site-specific source water classification of Bin 1 - 4.

The TCEQ has observed SWMOR customizations in low-pressure membrane plants that do not match the approved values. The SWMOR form cannot evaluate compliance correctly if the form has been improperly customized. The most common errors are: a) failure to use the most recent version of a site-specific approval letter, b) incorrect entry of a UCL from the DIT values letter, and c) incorrect entry of *Giardia* and virus inactivation requirements from the CT Study letter.

E. Common Record Keeping Issues

Here is a good rule of thumb to follow for record-keeping - if it isn't documented, it wasn't done. If the TCEQ requires you to monitor something, calibrate something, verify something, report something, etc., you should keep a record of it to prove that you actually did it. The record could be as simple as a short note in the plant's daily log. On the other hand, it could be an extensive electronic record of continuous monitoring data.

If you cannot access the required records, then the records are useless. This can be a concern with electronic records stored in proprietary SCADA systems. You must be able to retrieve records when required by the TCEQ. Work with your equipment manufacturer, SCADA manufacturer, or SCADA technician to move electronic records to a location and format that you can readily access.

The TCEQ frequently observes these specific record keeping issues:

1. Failure to keep instrument calibration and verification records

This issue is related to the Common Monitoring Issues, "Improperly calibrated measurement devices" (Section C.7.) described above. You must keep a record of each calibration and verification performed on a piece of testing equipment to document that you met those requirements. For example, add a place to enter the value of the pH meter verification next to the pH readings of samples for disinfection process data on your daily lab sheet.

2. Failure to keep electronic records for required amounts of time

The record keeping requirements for a particular type of data are the same whether the data is recorded in a hand-written log or stored in an electronic format. If you keep electronic records of data, make sure that you understand how long that data will be stored by the recording device or SCADA system before it is deleted. For example, a turbidity data recorder that deletes data after 6 months cannot be used to meet TCEQ record keeping requirements. In this example, the data must be extracted from the

recorder and transferred to a different storage location that does meet TCEQ requirements.

3. Failure to document when a plant is on and off

It is important to have a record of when the plant, each membrane unit, and every other major treatment unit is on (treating water) and off (not treating water). Plant monitoring data recorded while the plant is off, or data from an individual treatment unit while it is offline for maintenance, should not be reported in the SWMOR. This is particularly important for determining which maximum turbidity reading to report for each individual filter unit. Be sure to record when conventional filters are backwashed and are in filter-to-waste mode. If there is no record of when the plant or individual units are off, there is no way to justify excluding unrepresentative data from the reports to TCEQ.

4. Failure to document all DITs

A record of all DITs must be kept. For example, it is not sufficient for the control system to only keep a record of the last DIT that was performed on a membrane unit. If multiple DITs are performed in a single day, the operator must have access to records of all the DITs to properly fill out the SWMOR for that day.

It is equally important to keep a record of DITs that were initiated but did not complete, such as a DIT that timed out because the starting pressure would not stabilize. The records of incomplete DITs should be kept to diagnose why automatically scheduled DITs did not occur.

Appendix A

Cross-connection Controls around Low-pressure Membranes

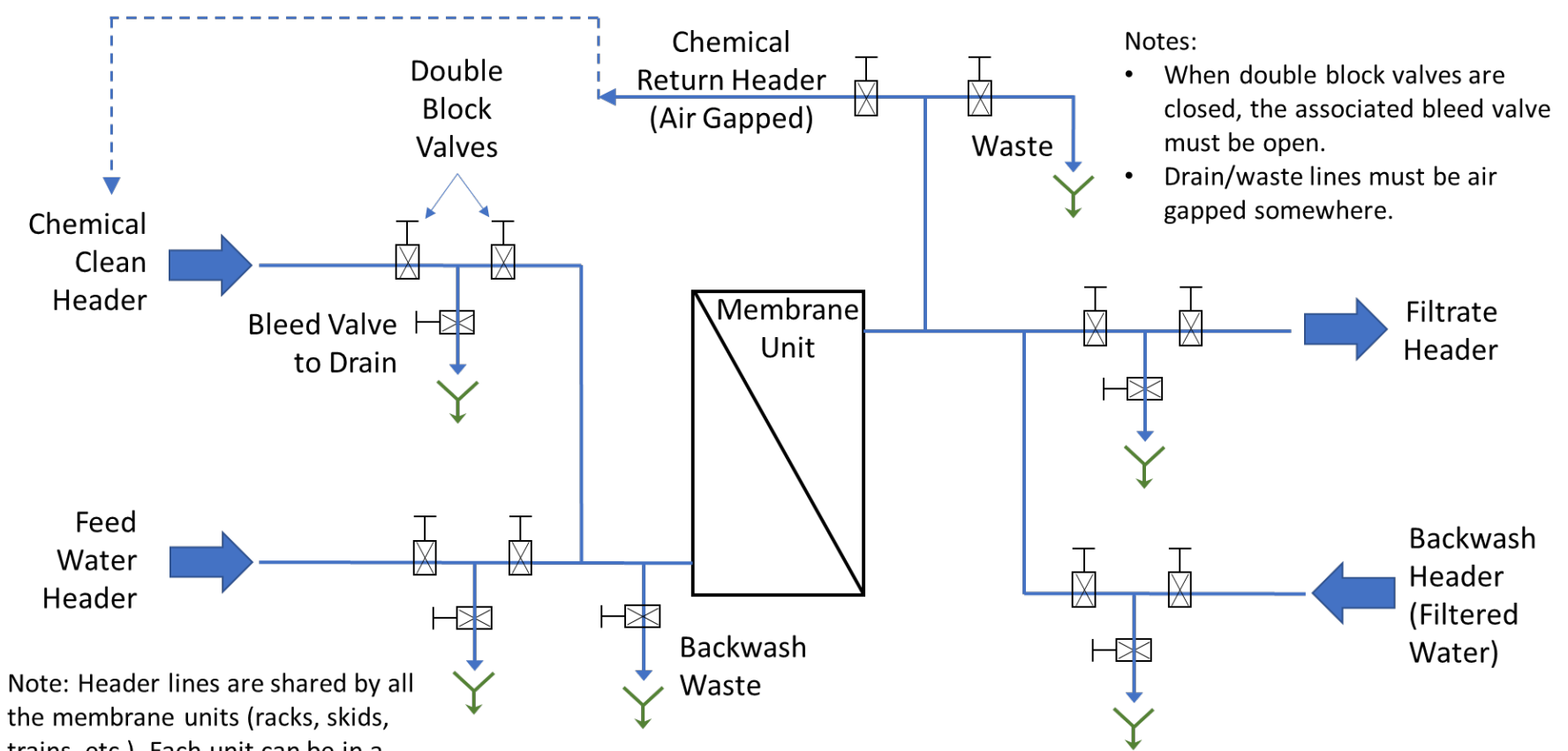

- Notes:
- When double block valves are closed, the associated bleed valve must be open.
 - Drain/waste lines must be air gapped somewhere.

Note: Header lines are shared by all the membrane units (racks, skids, trains, etc.). Each unit can be in a different state of operation. These controls protect the headers from contamination.

Common Arrangement of Double Block and Bleed Valves around a Low-Pressure Membrane Unit [30 TAC 290.42(g)(3)(F)]

