

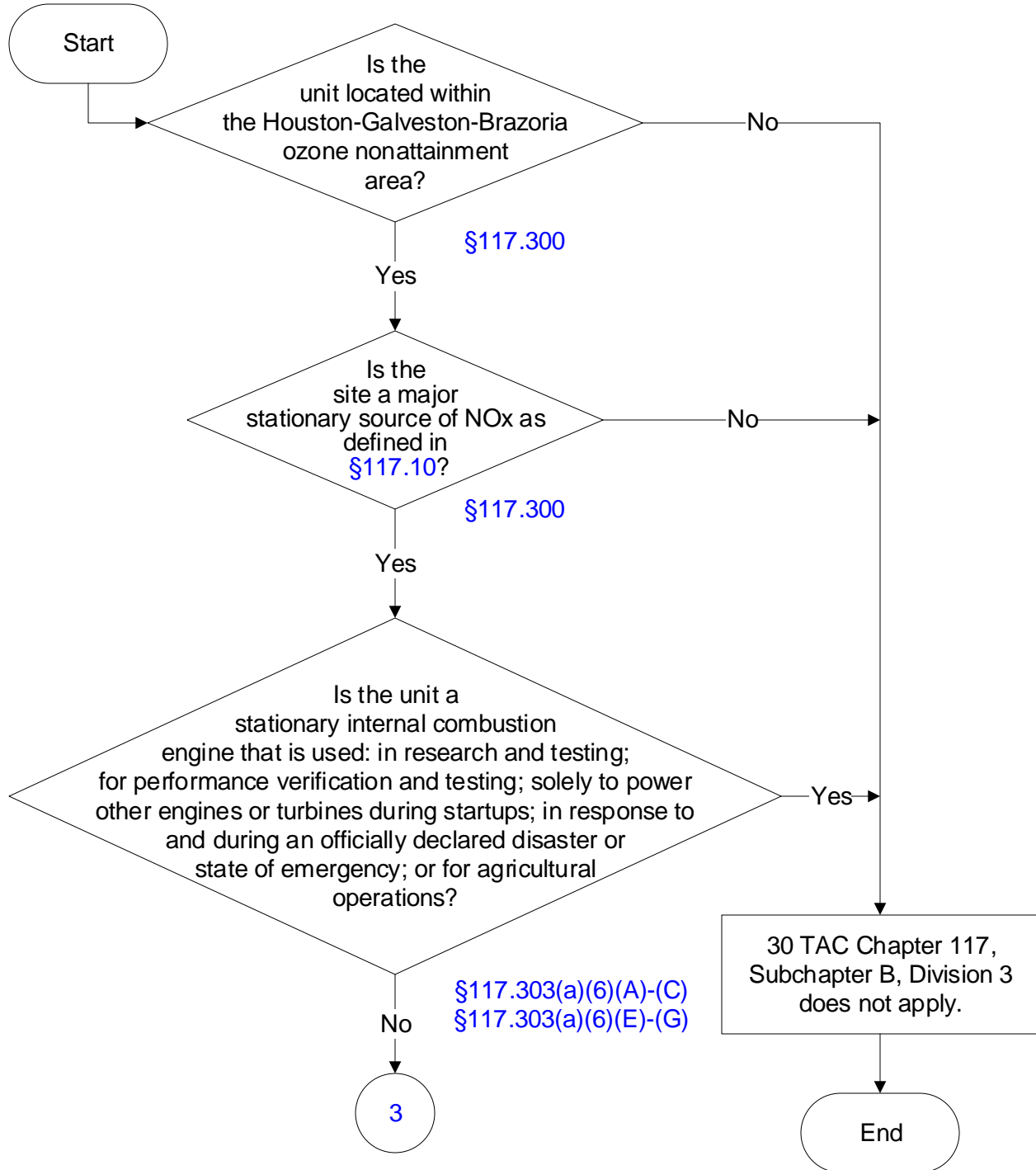

Below is a flowchart describing 30 TAC Chapter 117, Subchapter B, Division 3: Engines. It will likely not be accessible using a screen reader. For the text of the statute/rule, please go to [30 TAC Chapter 117, Subchapter B, Division 3: Engines](#) (1 of 36)

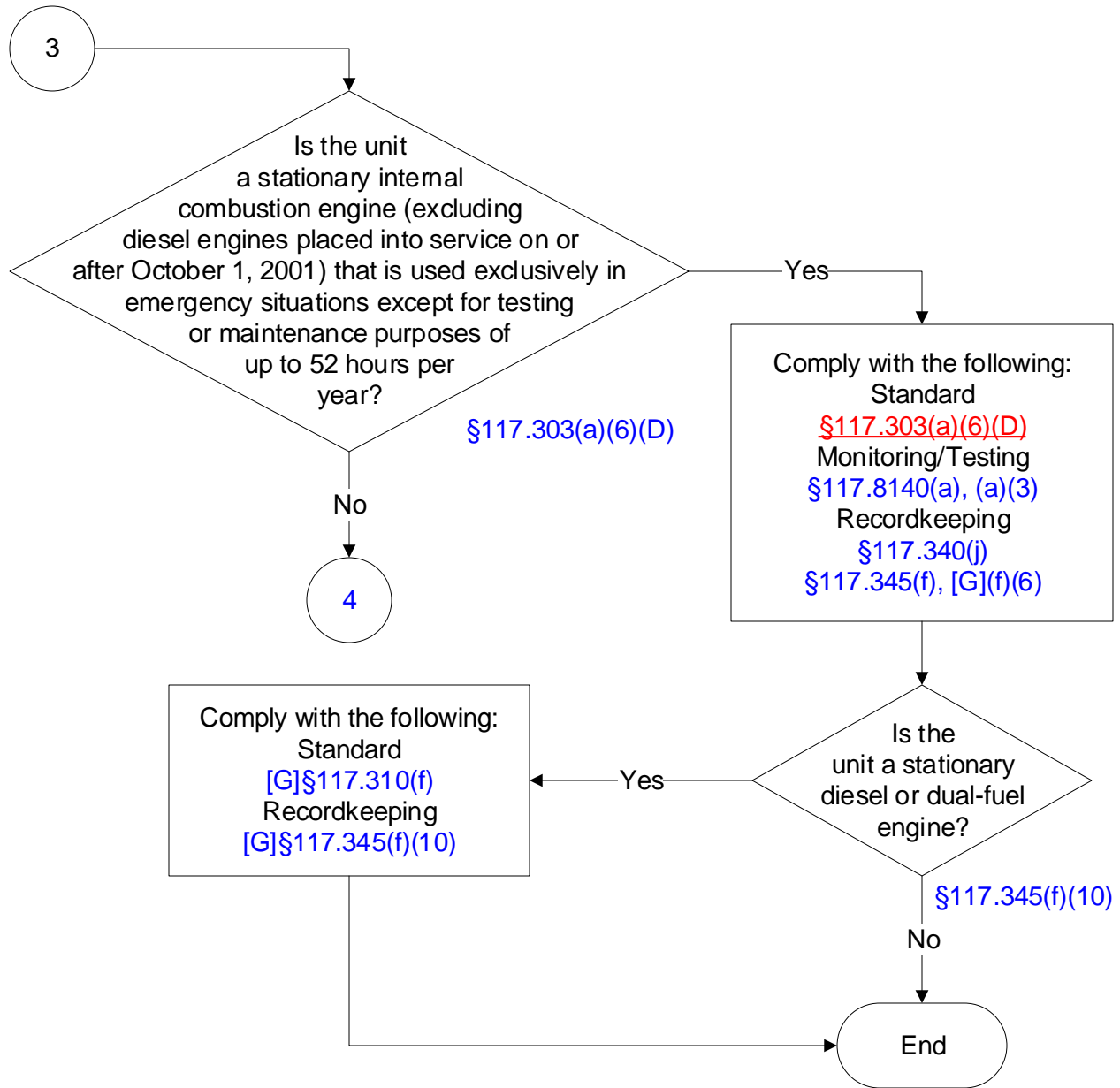

Combustion Control at Major ICI Sources Division 3: Engines
Houston-Galveston-Brazoria Ozone Nonattainment Area
(2 of 36)



**Combustion Control at Major ICI Sources Division 3: Engines
Houston-Galveston-Brazoria Ozone Nonattainment Area
(3 of 36)**

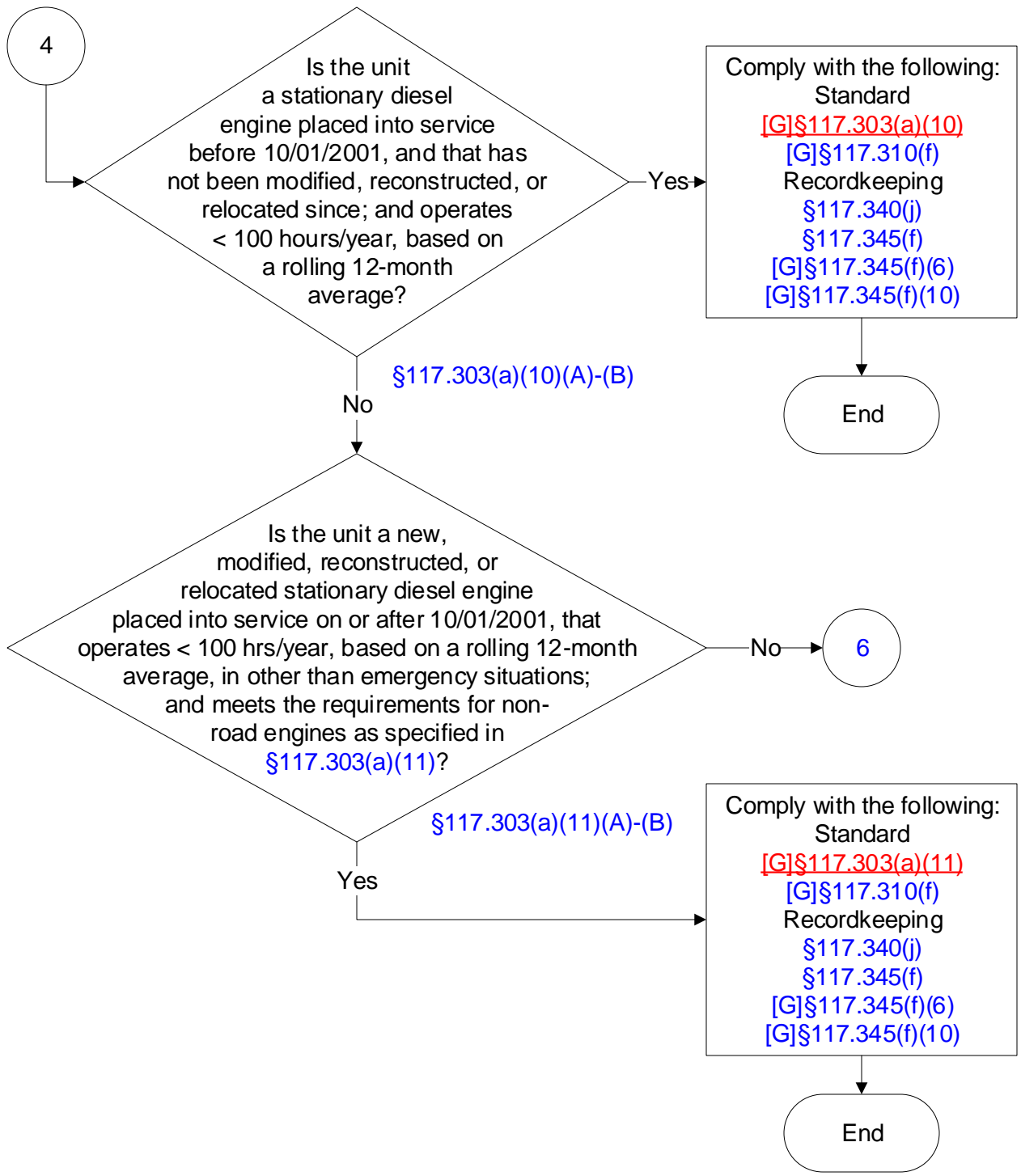

**Combustion Control at Major ICI Sources Division 3: Engines
Houston-Galveston-Brazoria Ozone Nonattainment Area
(4 of 36)**

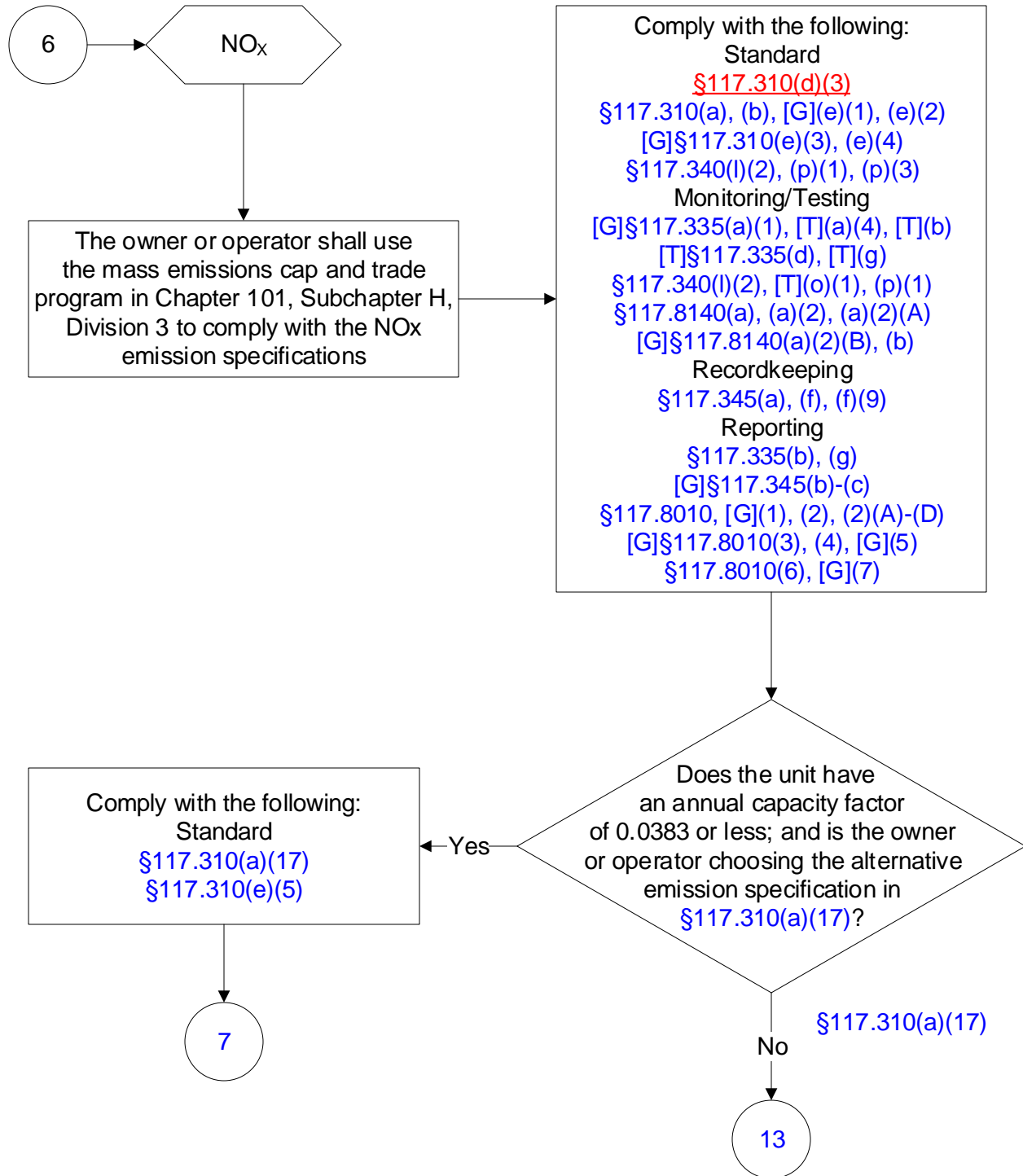

Combustion Control at Major ICI Sources Division 3: Engines
Houston-Galveston-Brazoria Ozone Nonattainment Area
(5 of 36)

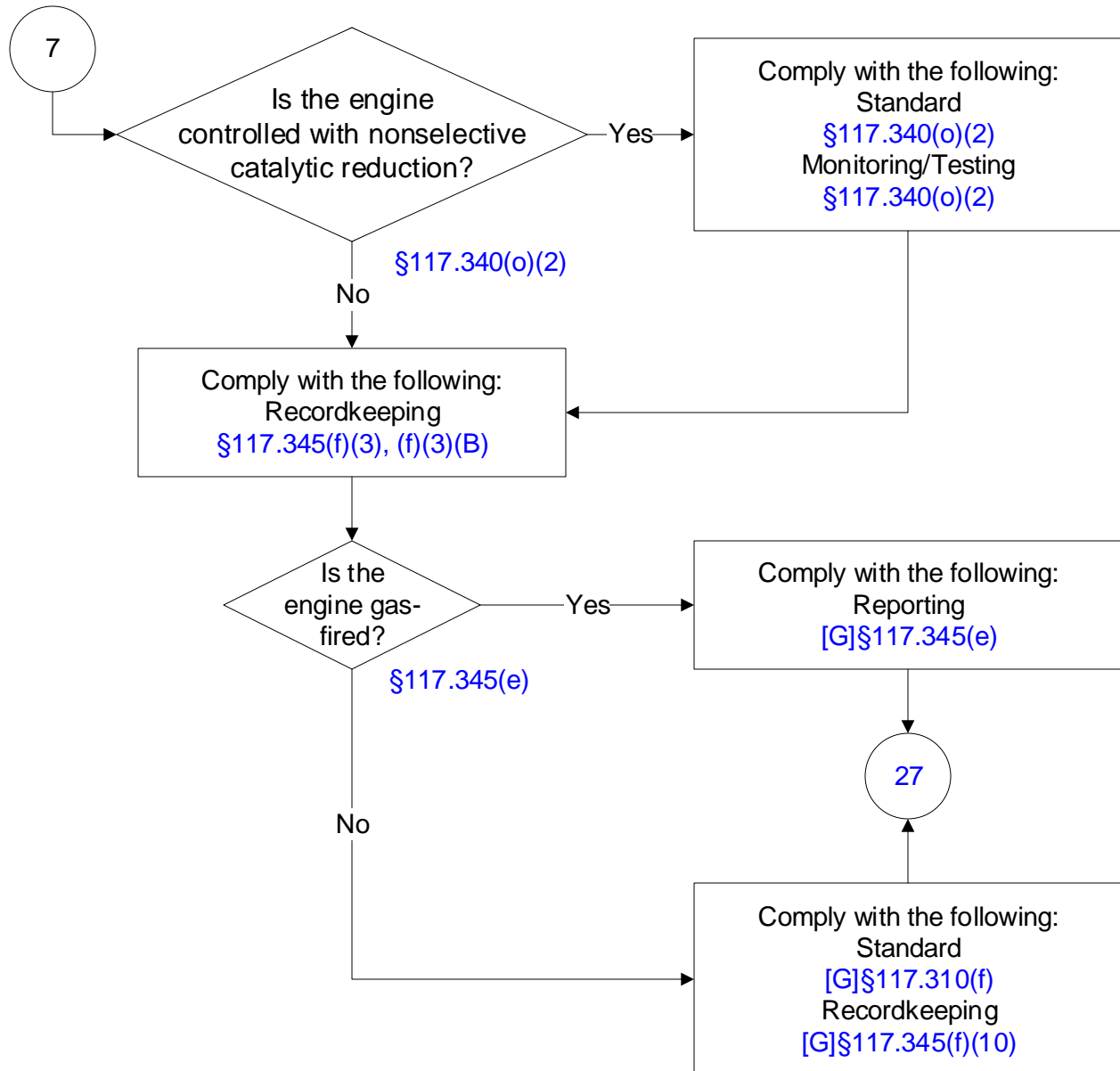

**Combustion Control at Major ICI Sources Division 3: Engines
Houston-Galveston-Brazoria Ozone Nonattainment Area
(6 of 36)**

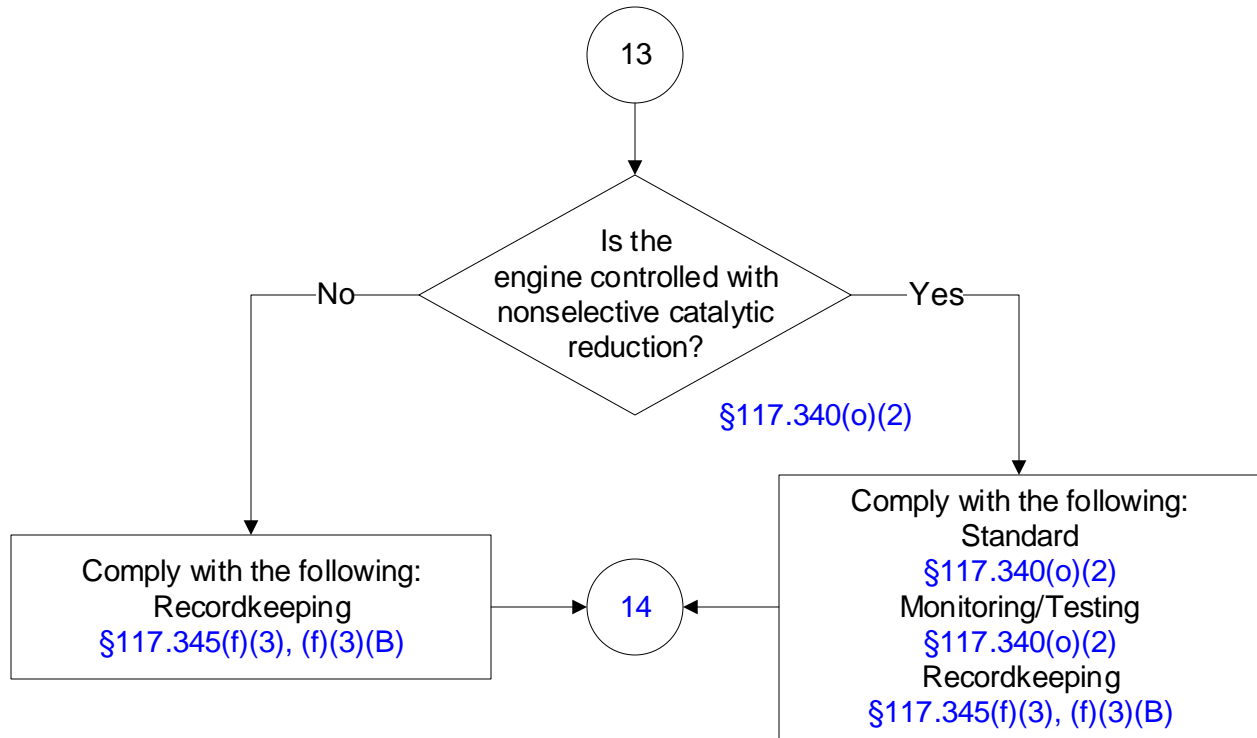

Combustion Control at Major ICI Sources Division 3: Engines
Houston-Galveston-Brazoria Ozone Nonattainment Area
 (7 of 36)

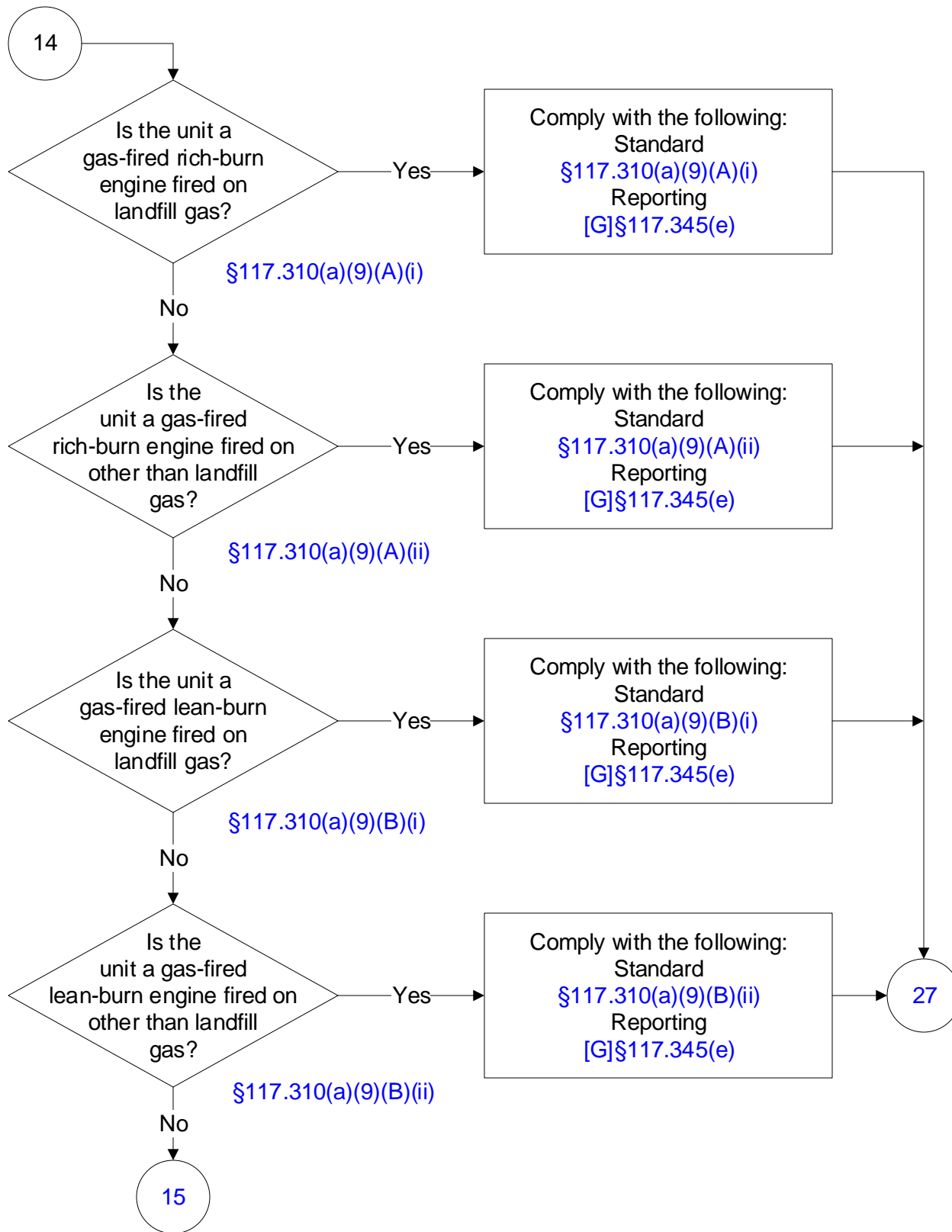

Combustion Control at Major ICI Sources Division 3: Engines
Houston-Galveston-Brazoria Ozone Nonattainment Area
 (8 of 36)

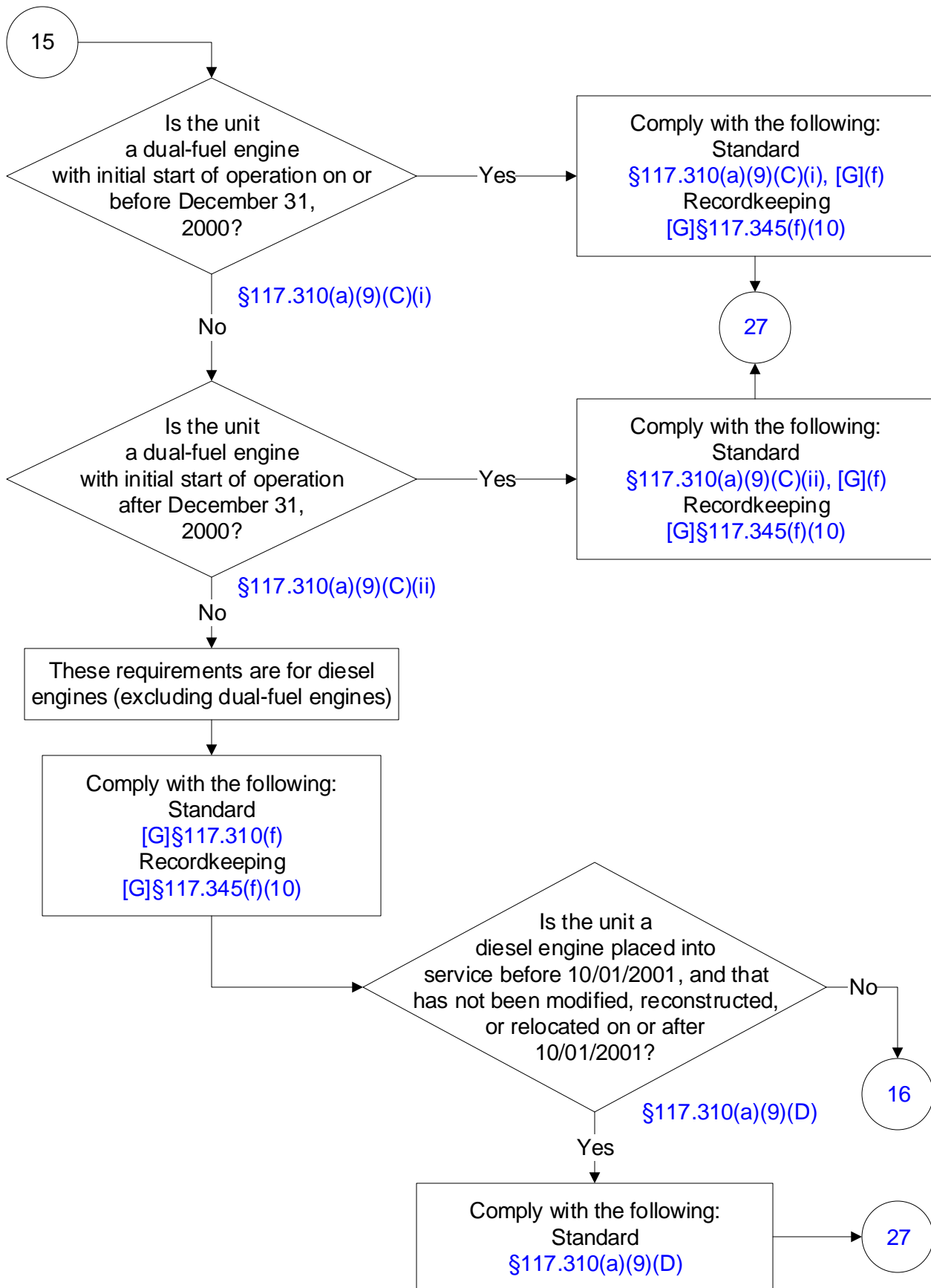

Combustion Control at Major ICI Sources Division 3: Engines
Houston-Galveston-Brazoria Ozone Nonattainment Area
(9 of 36)

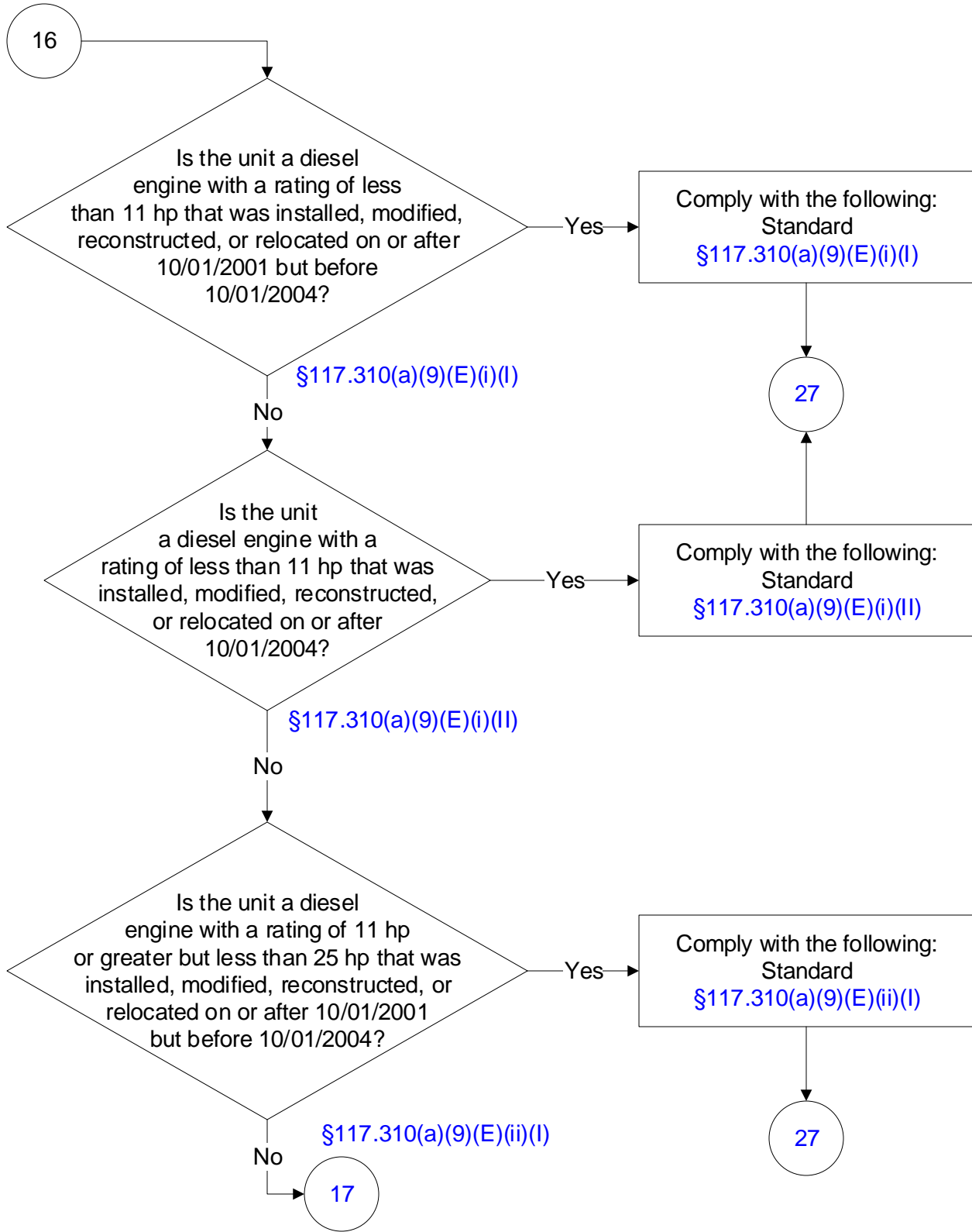

Combustion Control at Major ICI Sources Division 3: Engines
Houston-Galveston-Brazoria Ozone Nonattainment Area
 (10 of 36)

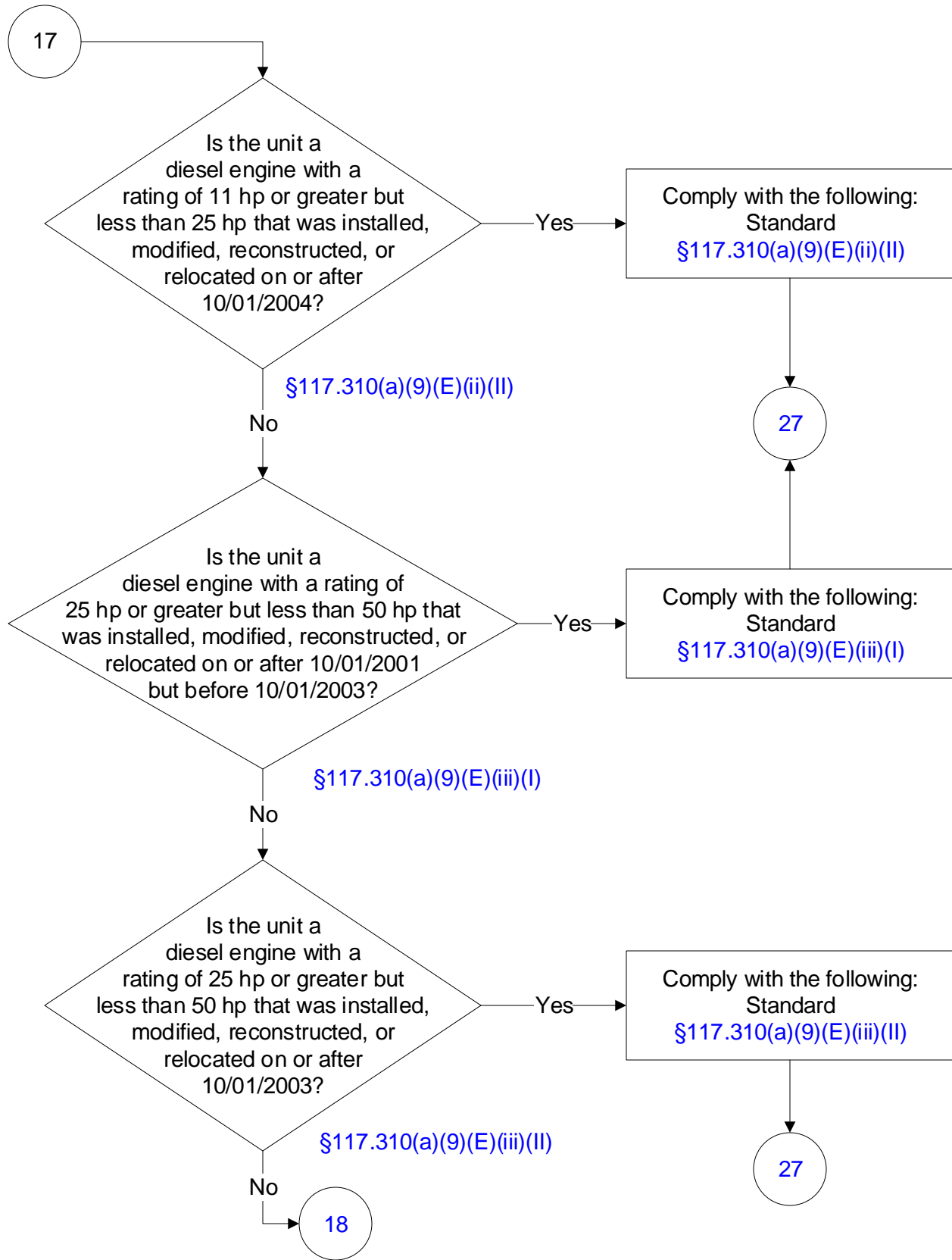

Combustion Control at Major ICI Sources Division 3: Engines
Houston-Galveston-Brazoria Ozone Nonattainment Area
(11 of 36)

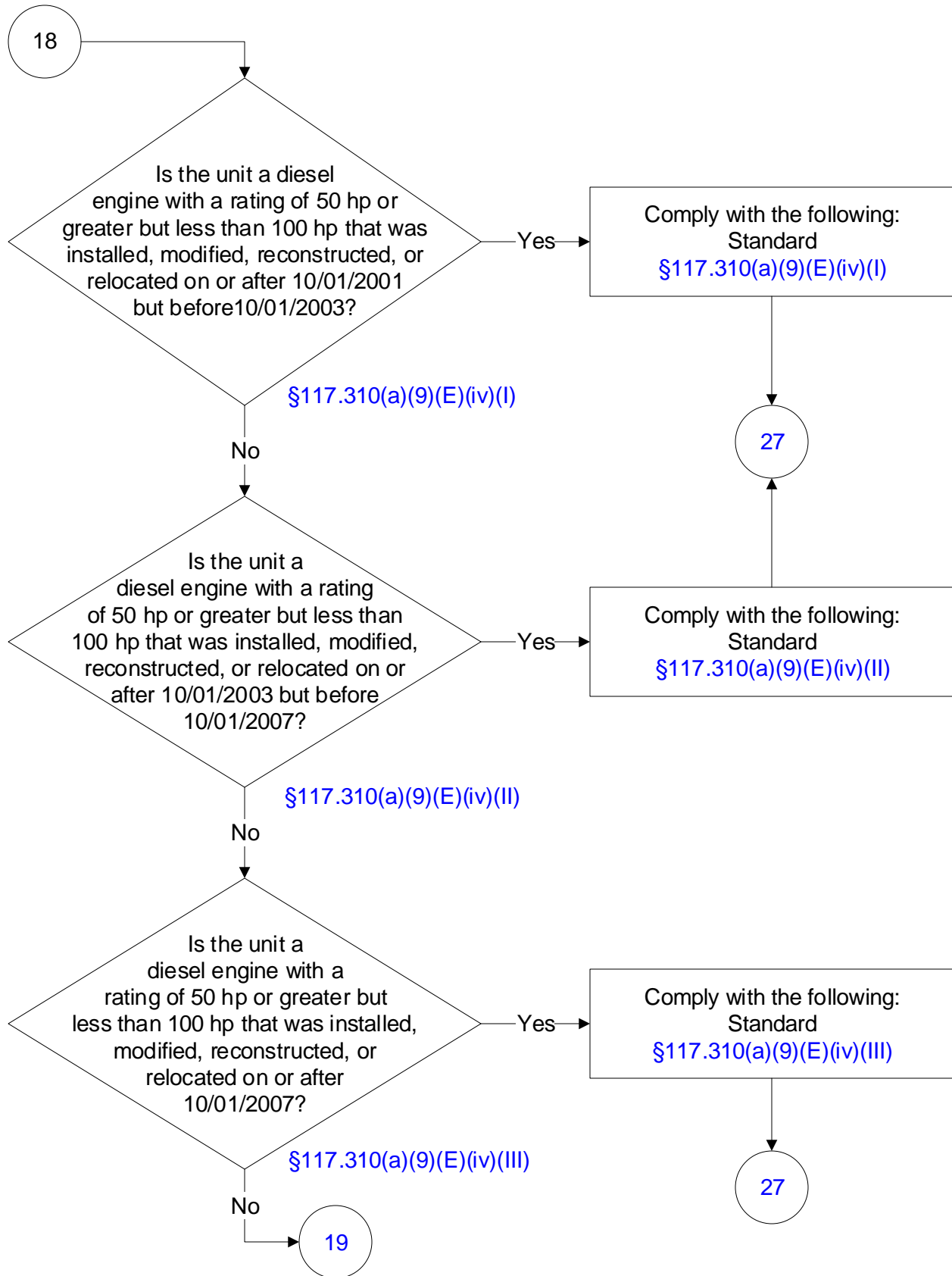

Combustion Control at Major ICI Sources Division 3: Engines
Houston-Galveston-Brazoria Ozone Nonattainment Area
 (12 of 36)

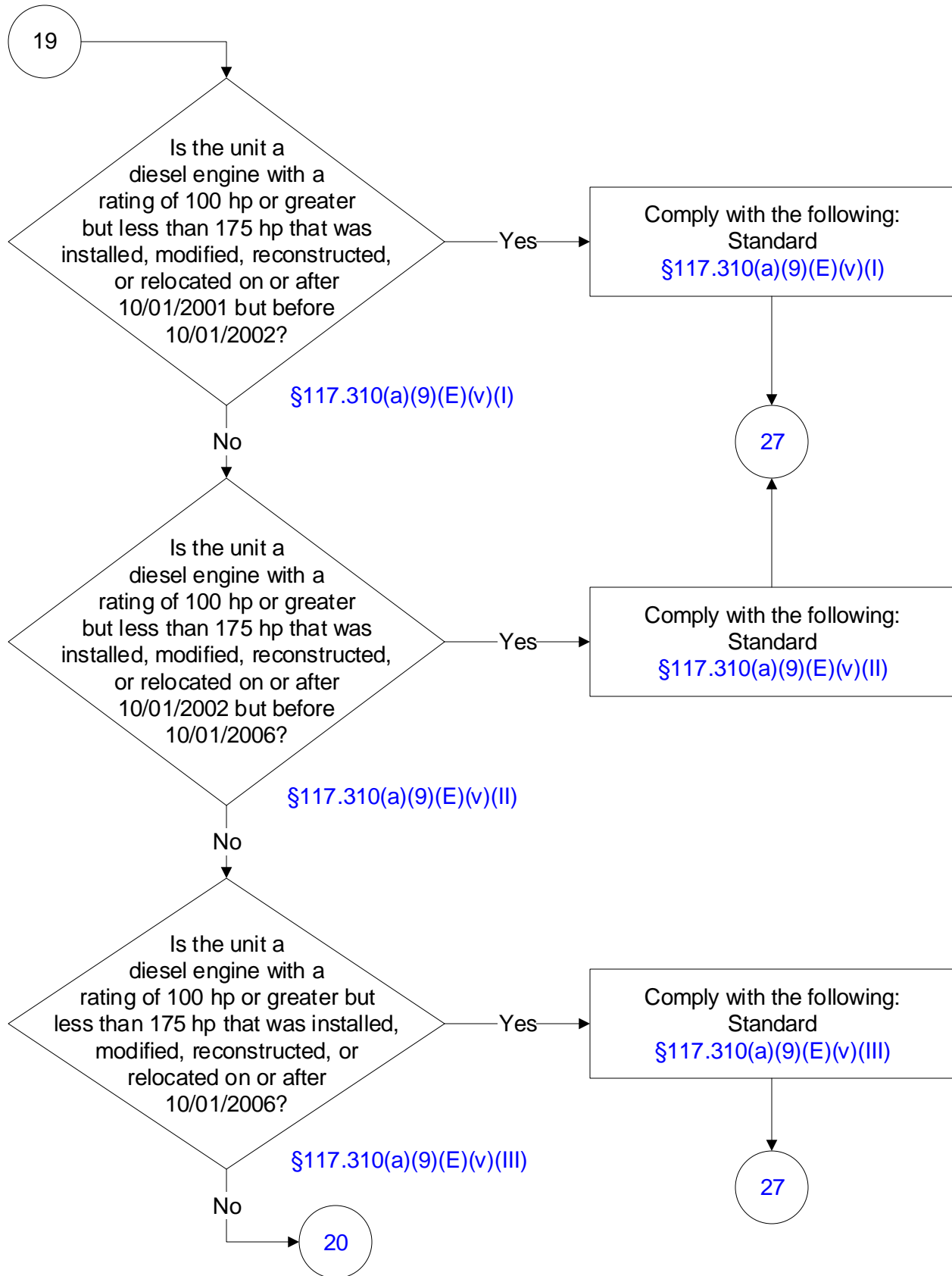

Combustion Control at Major ICI Sources Division 3: Engines
Houston-Galveston-Brazoria Ozone Nonattainment Area
 (13 of 36)

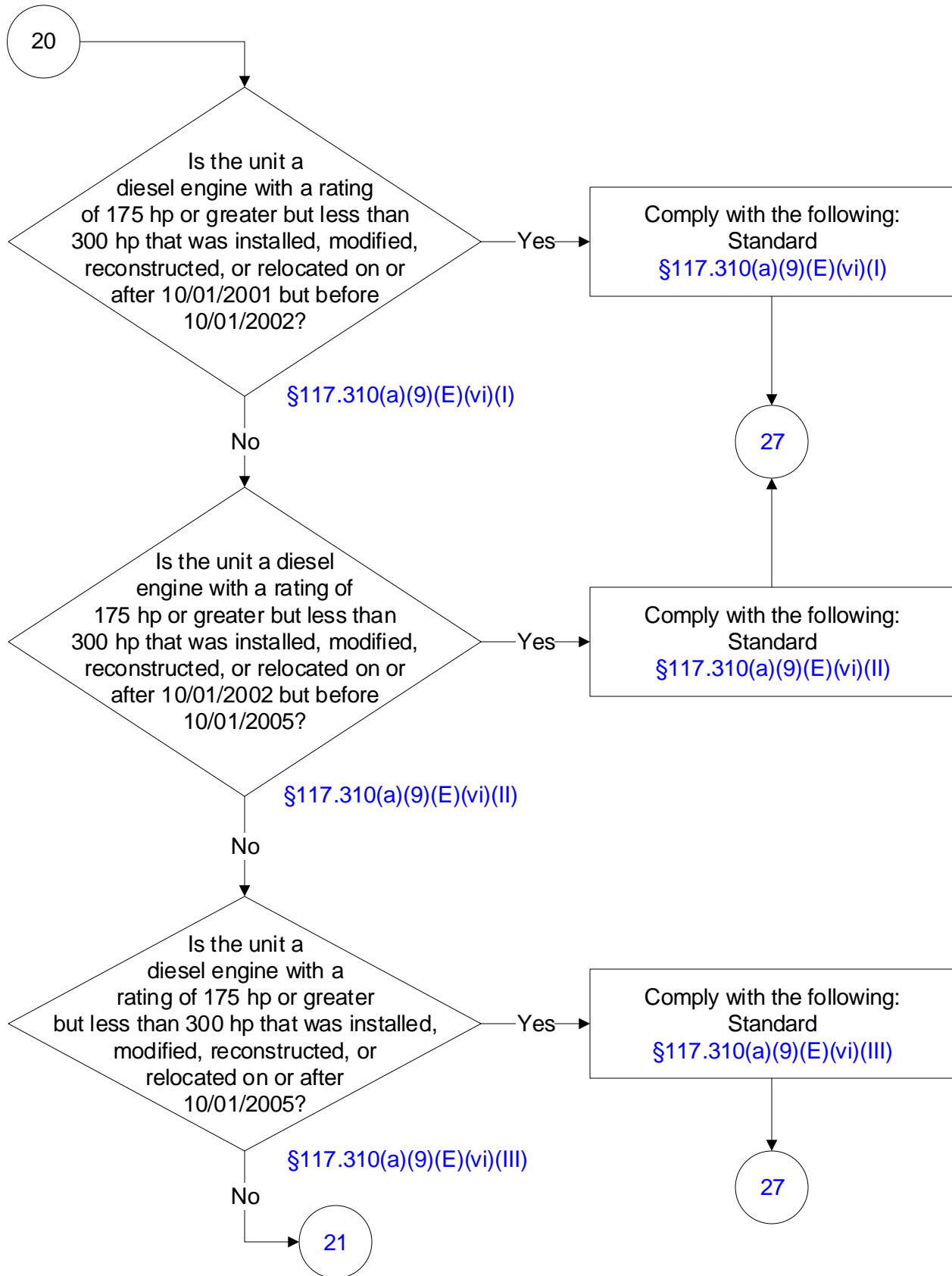

Combustion Control at Major ICI Sources Division 3: Engines
Houston-Galveston-Brazoria Ozone Nonattainment Area
 (14 of 36)

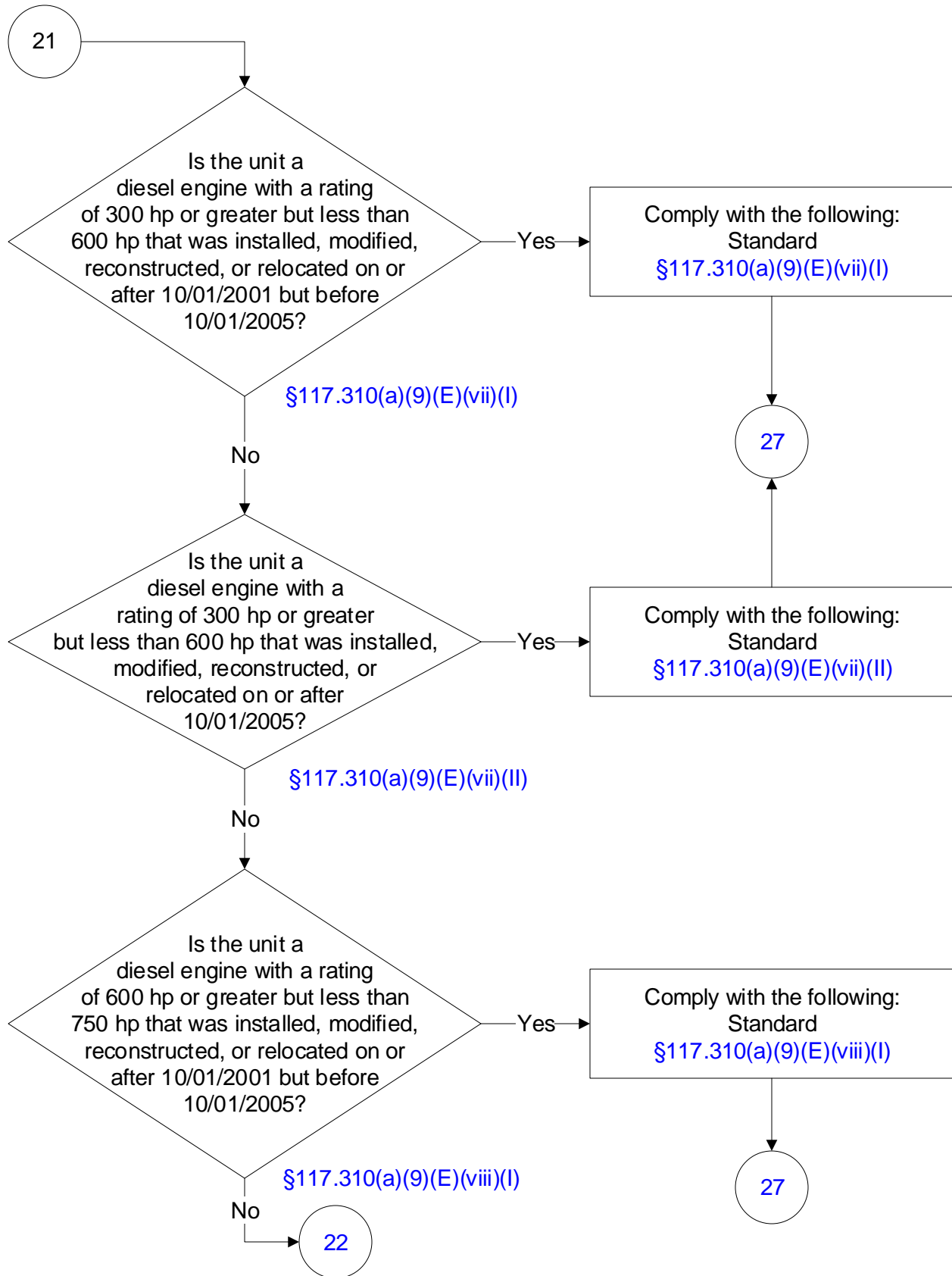

**Combustion Control at Major ICI Sources Division 3: Engines
Houston-Galveston-Brazoria Ozone Nonattainment Area
(15 of 36)**

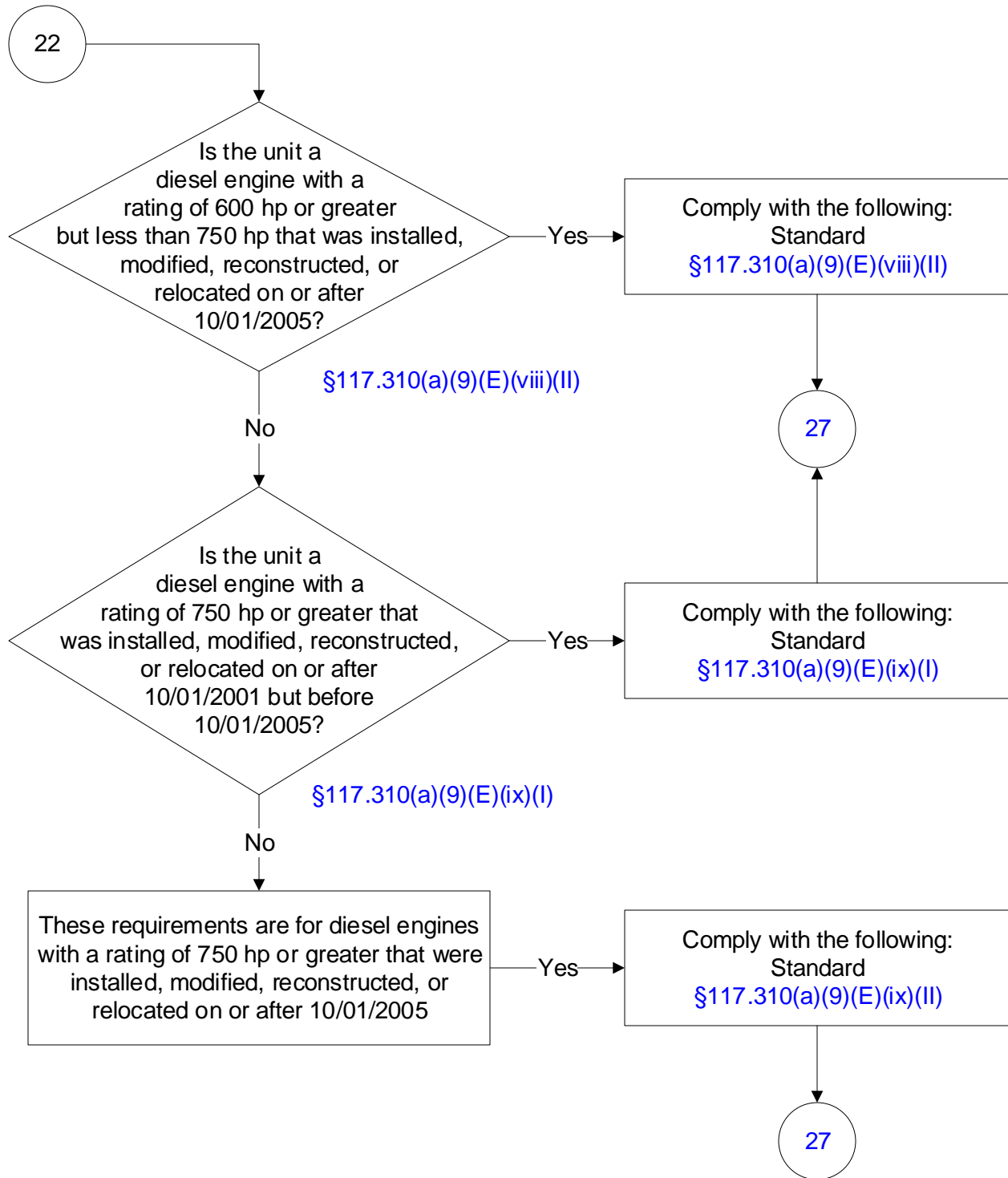

**Combustion Control at Major ICI Sources Division 3: Engines
Houston-Galveston-Brazoria Ozone Nonattainment Area
(16 of 36)**

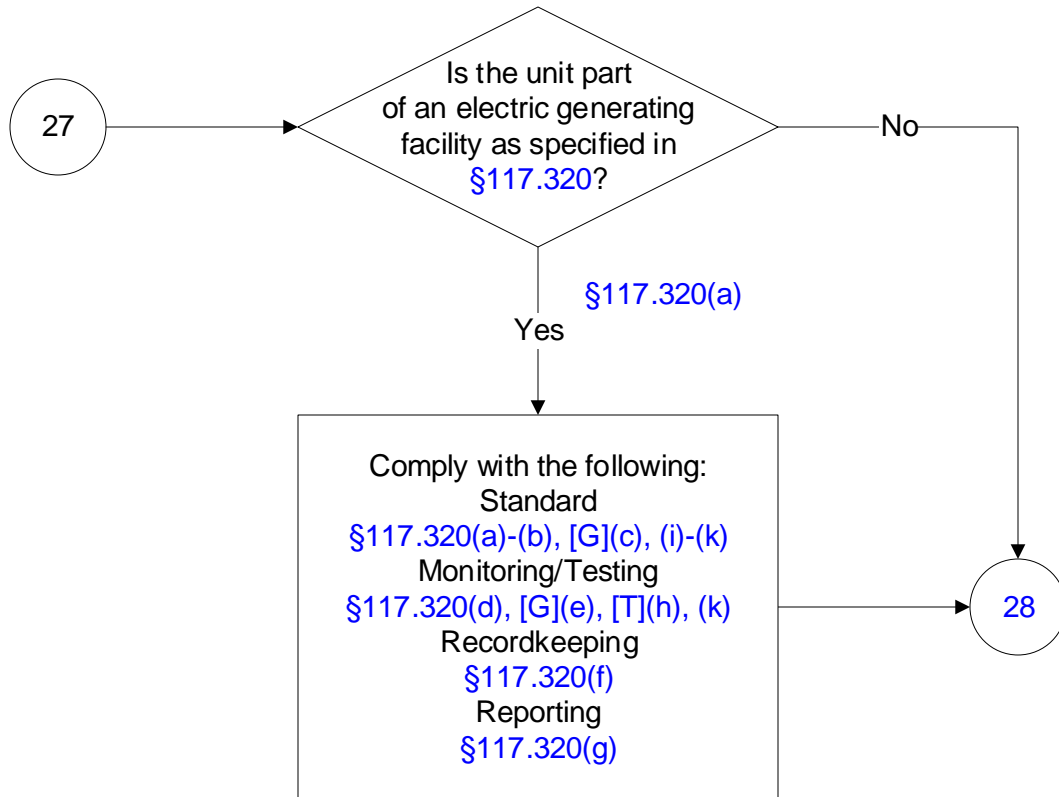

**Combustion Control at Major ICI Sources Division 3: Engines
Houston-Galveston-Brazoria Ozone Nonattainment Area
(17 of 36)**

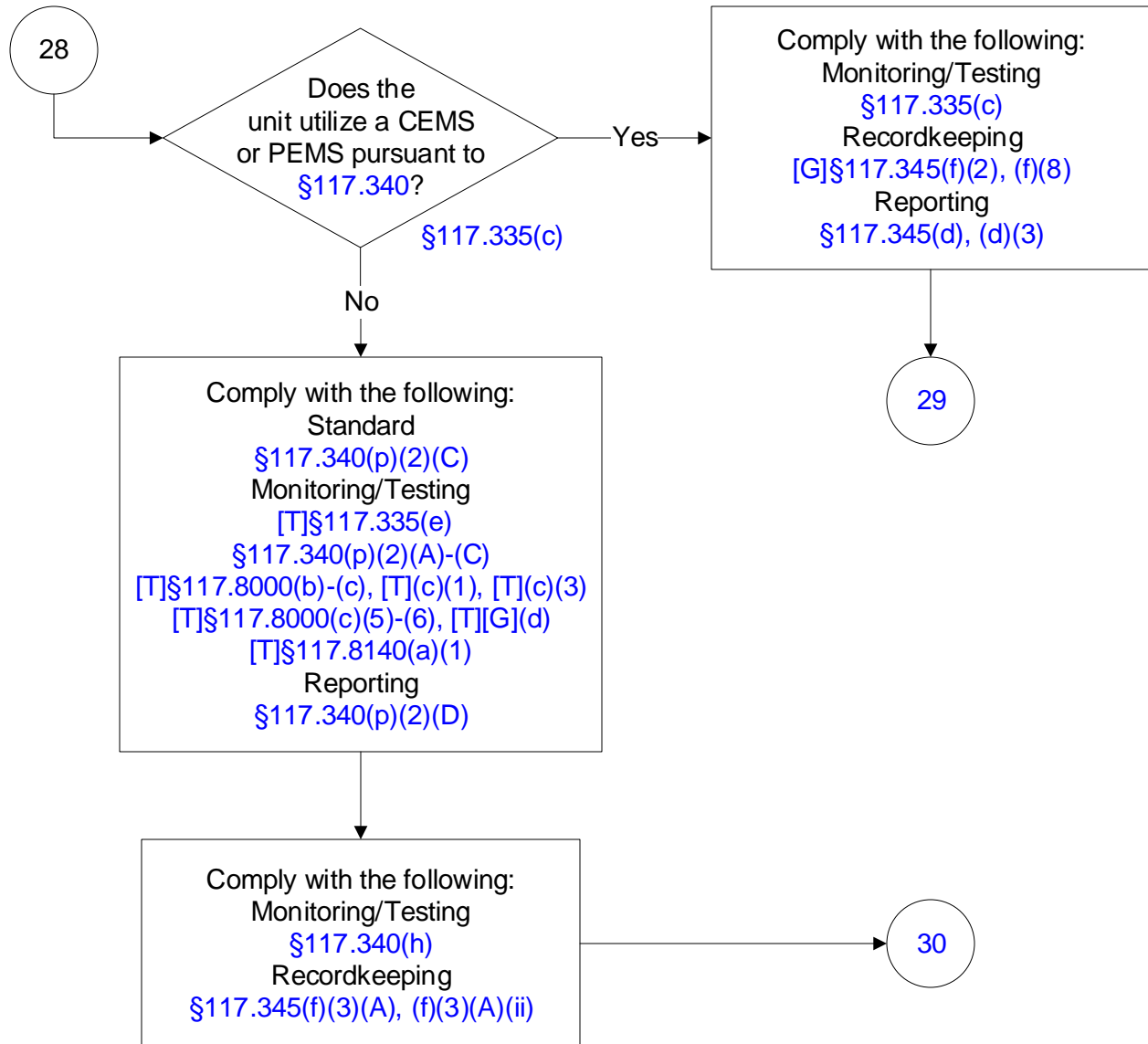

**Combustion Control at Major ICI Sources Division 3: Engines
Houston-Galveston-Brazoria Ozone Nonattainment Area
(18 of 36)**

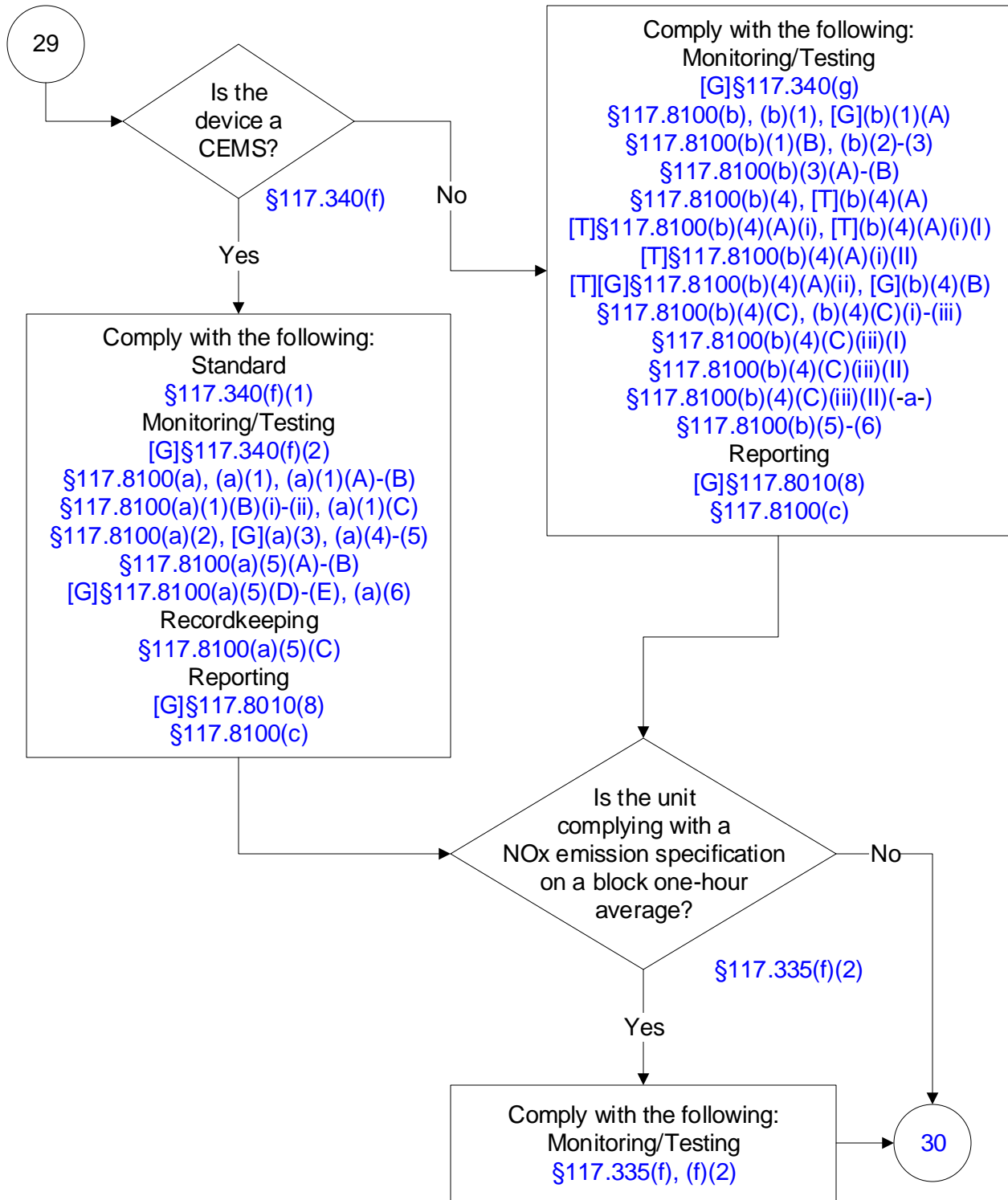

**Combustion Control at Major ICI Sources Division 3: Engines
Houston-Galveston-Brazoria Ozone Nonattainment Area
(19 of 36)**

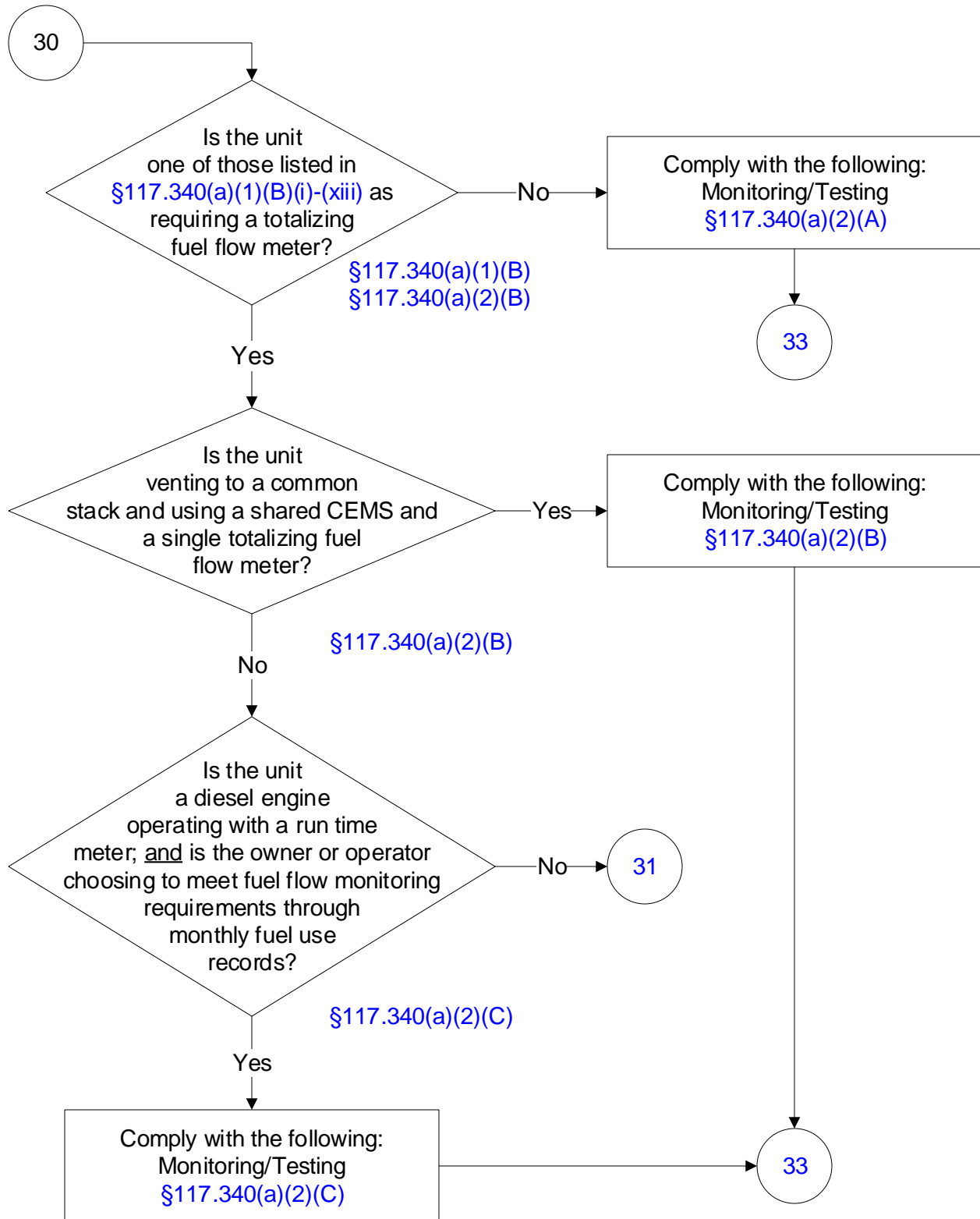

Combustion Control at Major ICI Sources Division 3: Engines
Houston-Galveston-Brazoria Ozone Nonattainment Area
(20 of 36)

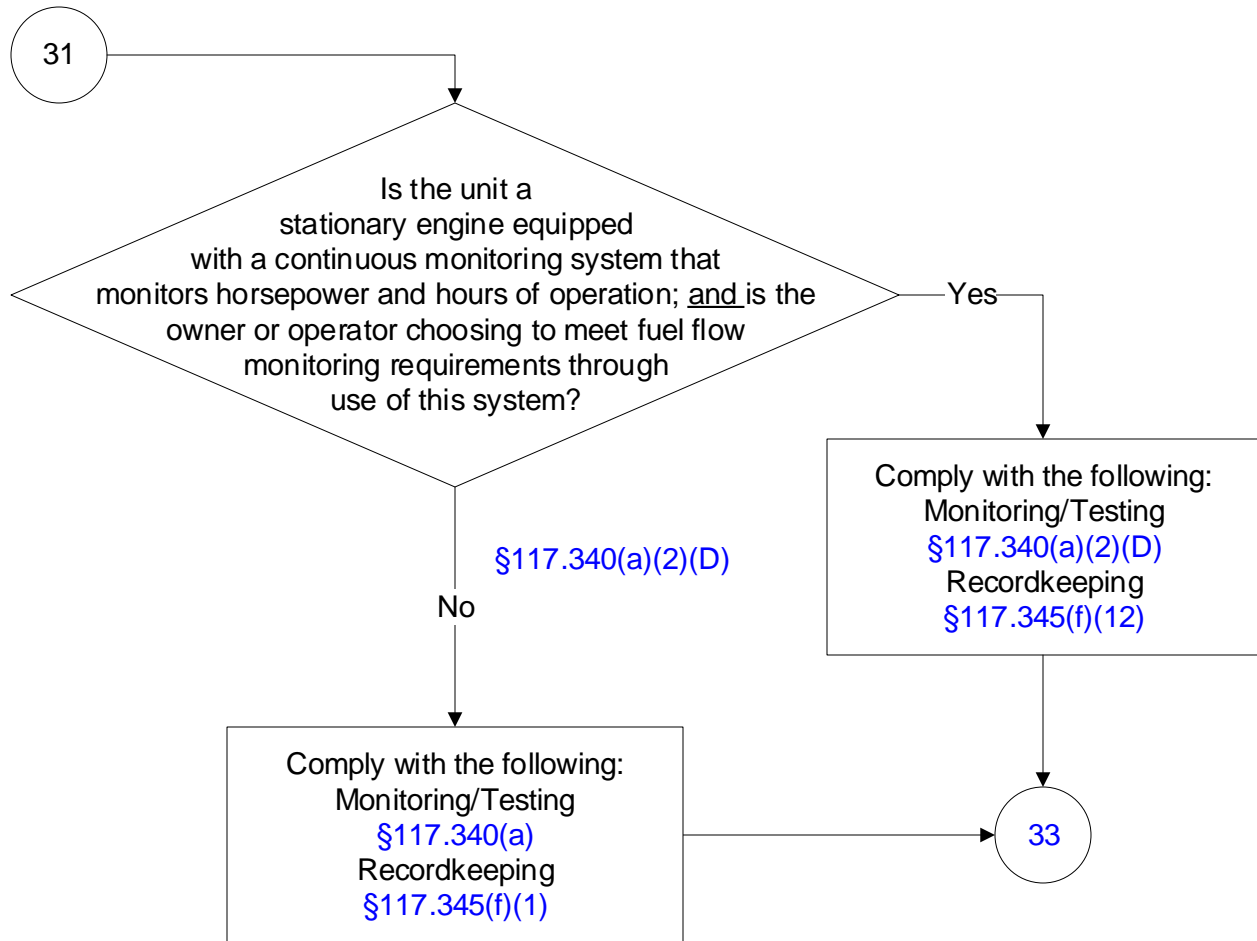

**Combustion Control at Major ICI Sources Division 3: Engines
Houston-Galveston-Brazoria Ozone Nonattainment Area
(21 of 36)**

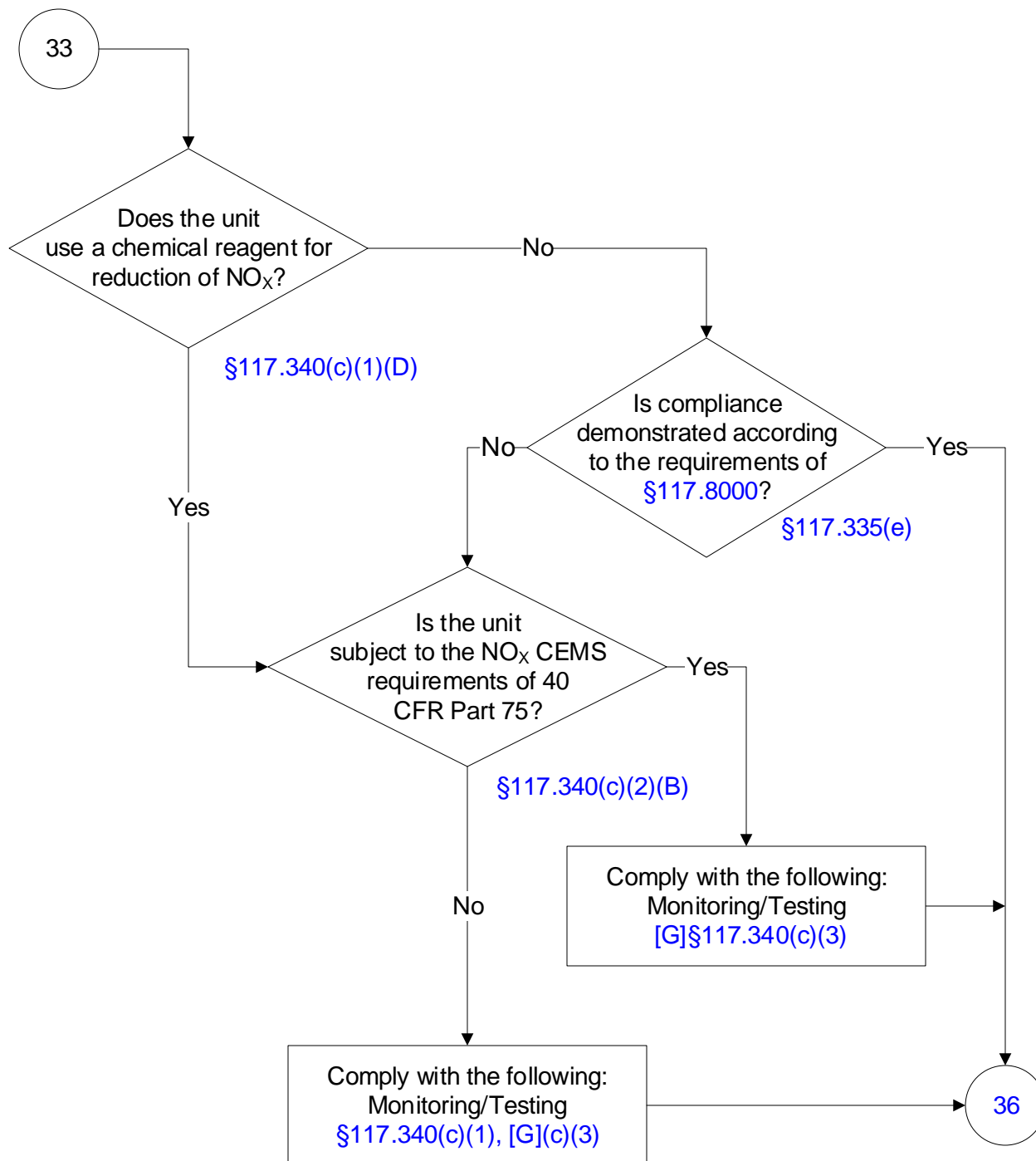

Combustion Control at Major ICI Sources Division 3: Engines
Houston-Galveston-Brazoria Ozone Nonattainment Area
(22 of 36)

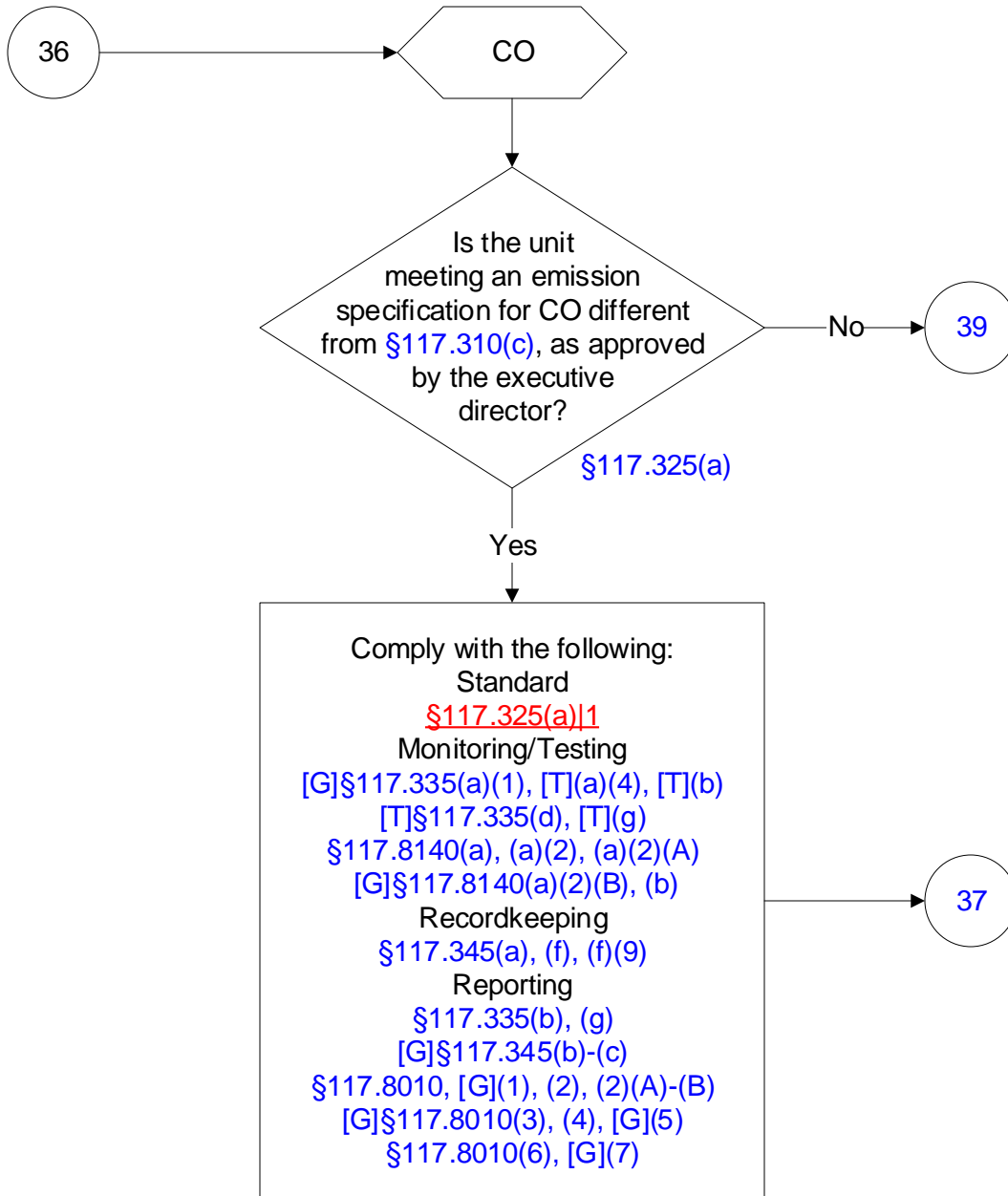

**Combustion Control at Major ICI Sources Division 3: Engines
Houston-Galveston-Brazoria Ozone Nonattainment Area
(23 of 36)**

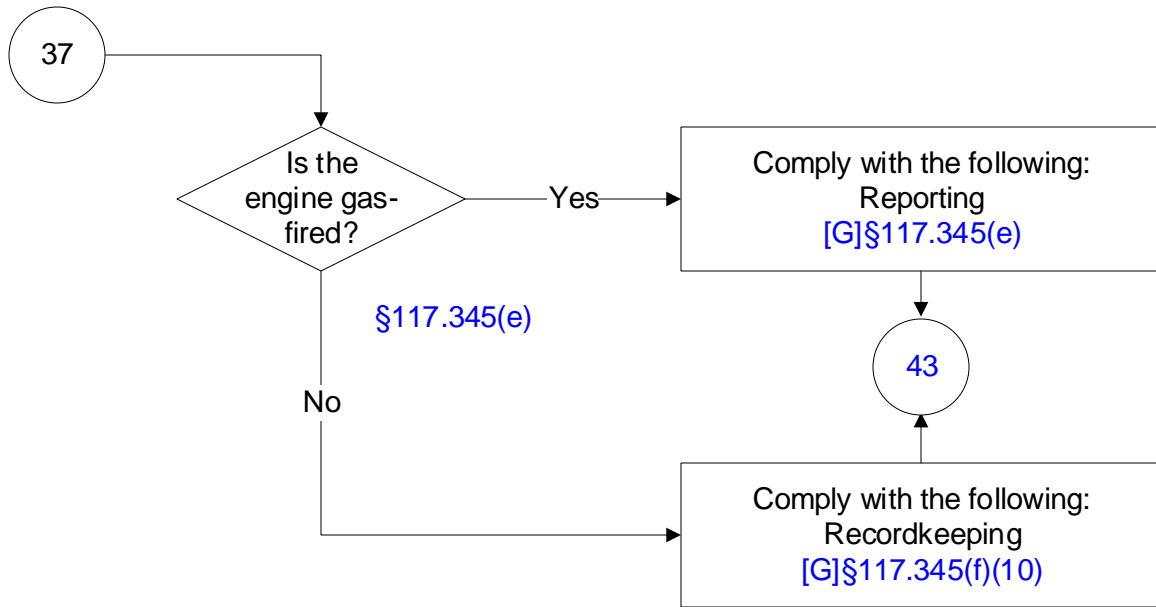

Combustion Control at Major ICI Sources Division 3: Engines
Houston-Galveston-Brazoria Ozone Nonattainment Area
 (24 of 36)

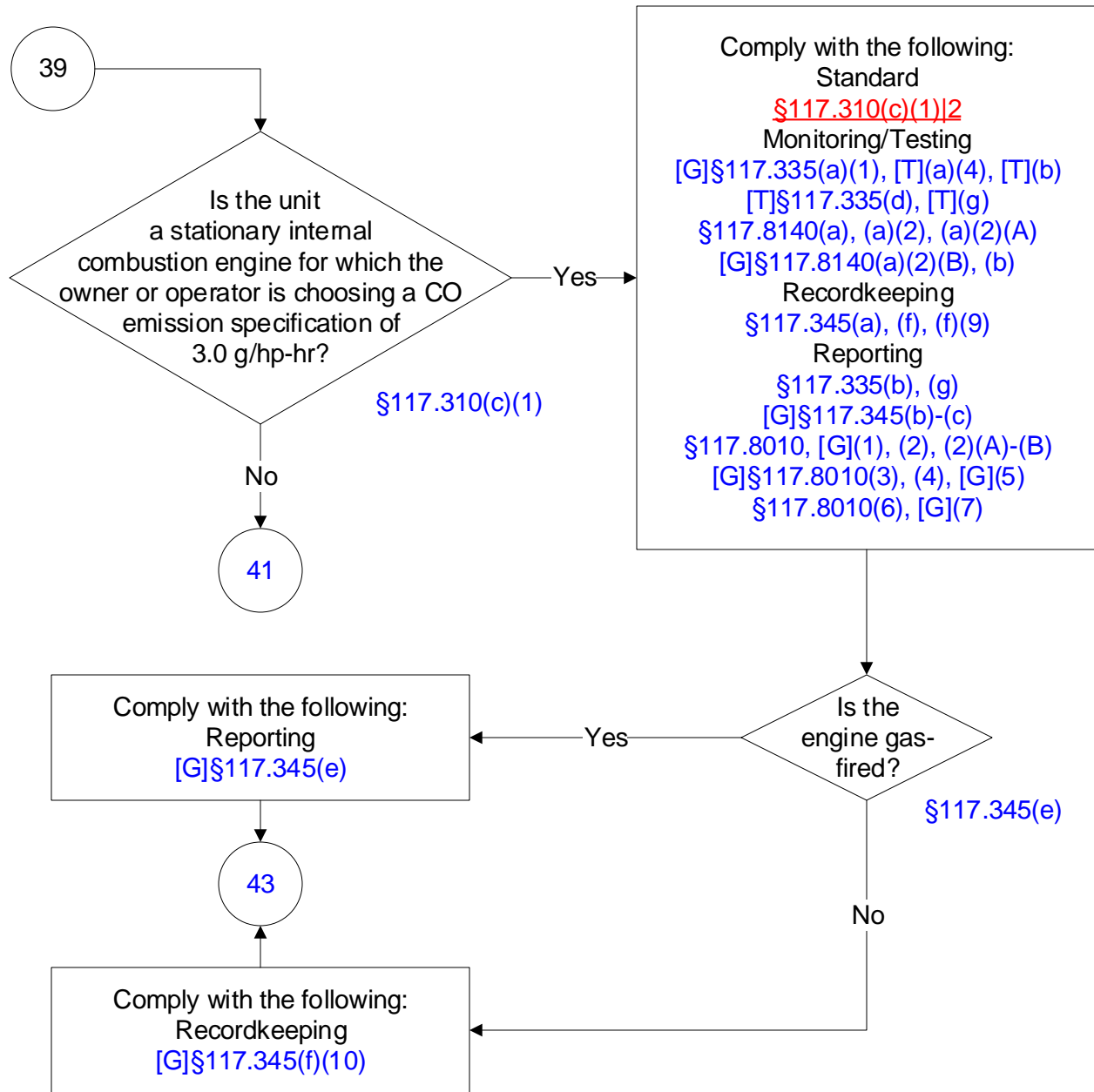

**Combustion Control at Major ICI Sources Division 3: Engines
Houston-Galveston-Brazoria Ozone Nonattainment Area
(25 of 36)**

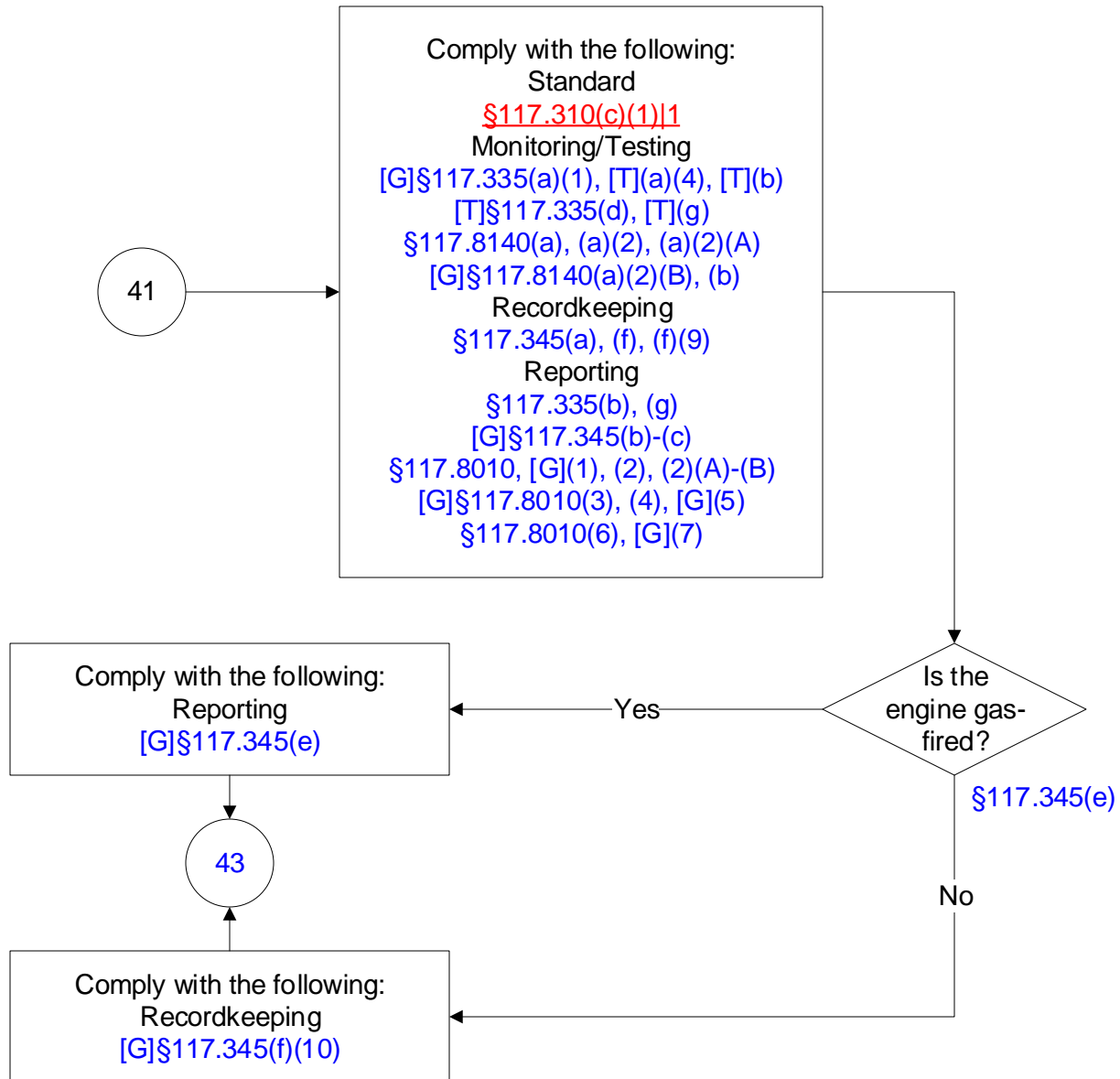

**Combustion Control at Major ICI Sources Division 3: Engines
Houston-Galveston-Brazoria Ozone Nonattainment Area
(26 of 36)**

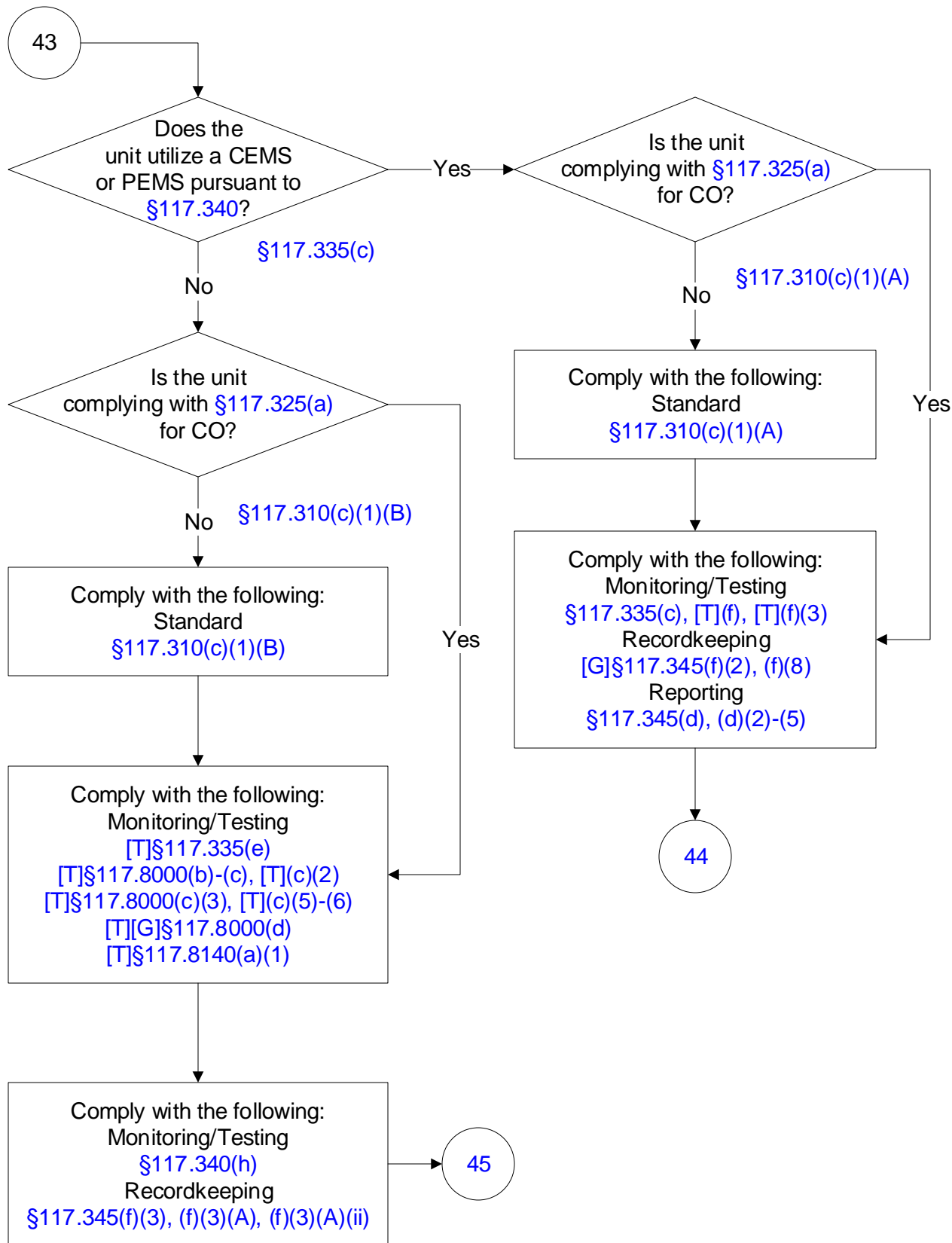

**Combustion Control at Major ICI Sources Division 3: Engines
Houston-Galveston-Brazoria Ozone Nonattainment Area
(27 of 36)**

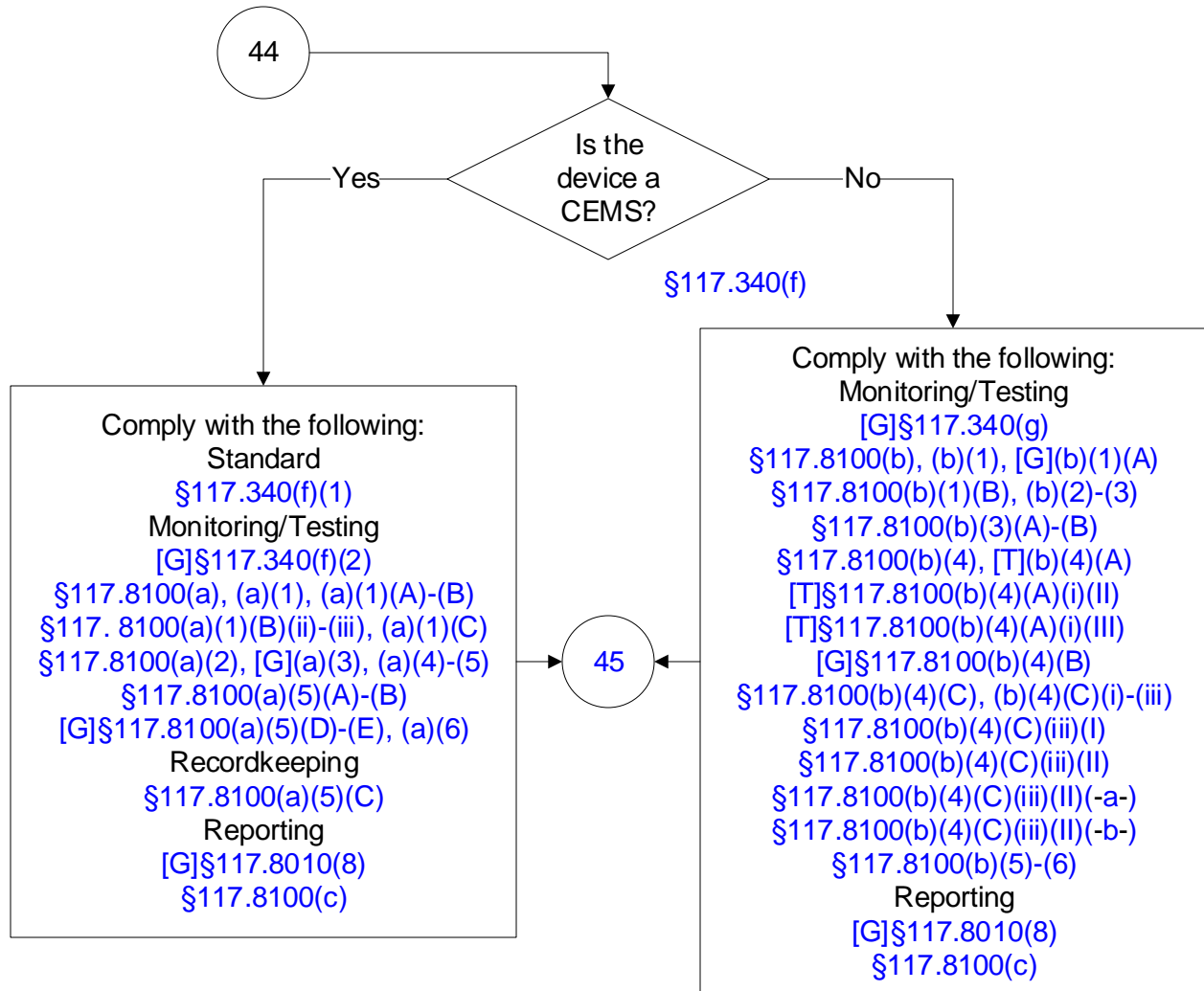

Combustion Control at Major ICI Sources Division 3: Engines
Houston-Galveston-Brazoria Ozone Nonattainment Area
 (28 of 36)

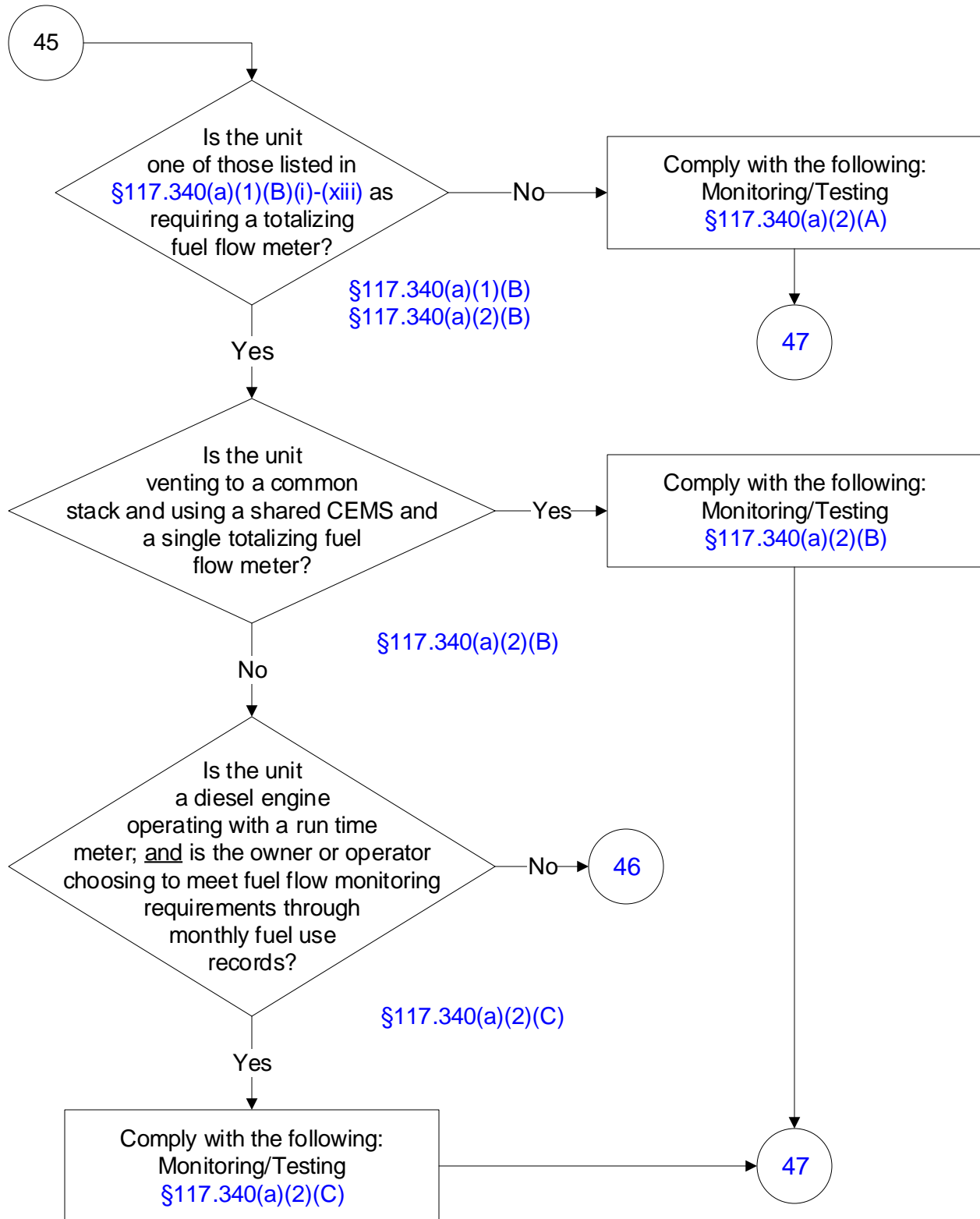

Combustion Control at Major ICI Sources Division 3: Engines
Houston-Galveston-Brazoria Ozone Nonattainment Area
(29 of 36)

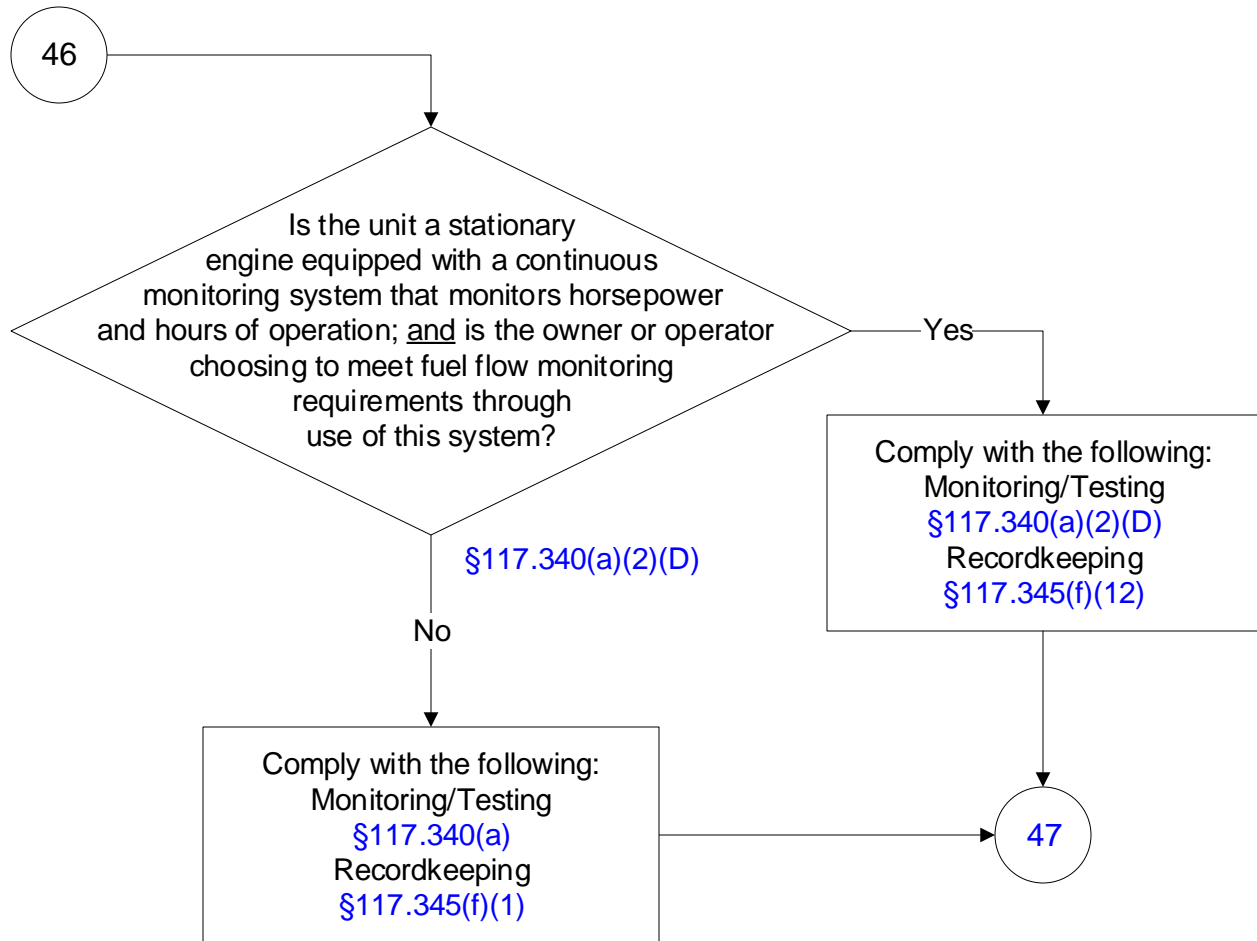

**Combustion Control at Major ICI Sources Division 3: Engines
Houston-Galveston-Brazoria Ozone Nonattainment Area
(30 of 36)**

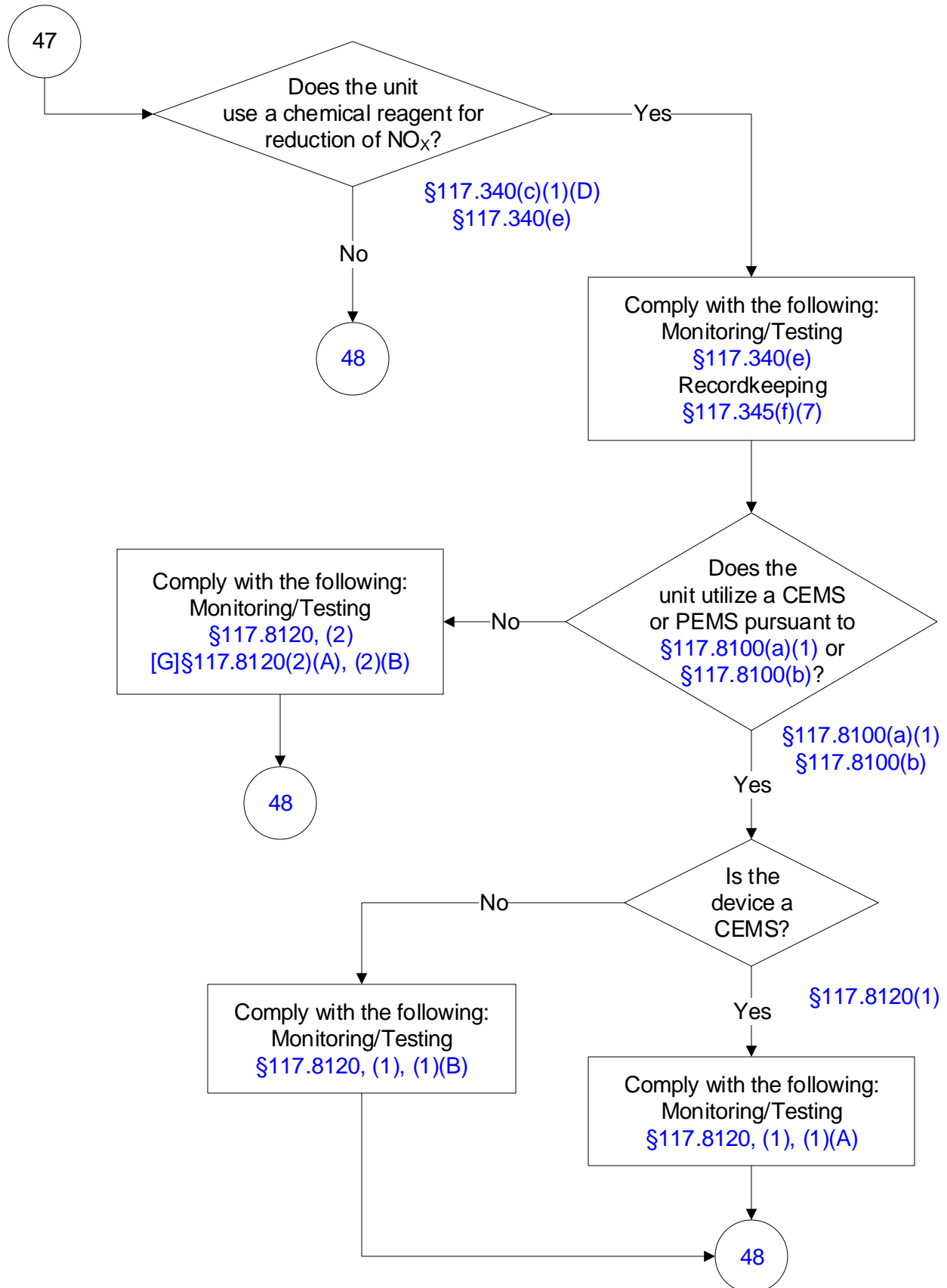

Combustion Control at Major ICI Sources Division 3: Engines
Houston-Galveston-Brazoria Ozone Nonattainment Area
 (31 of 36)

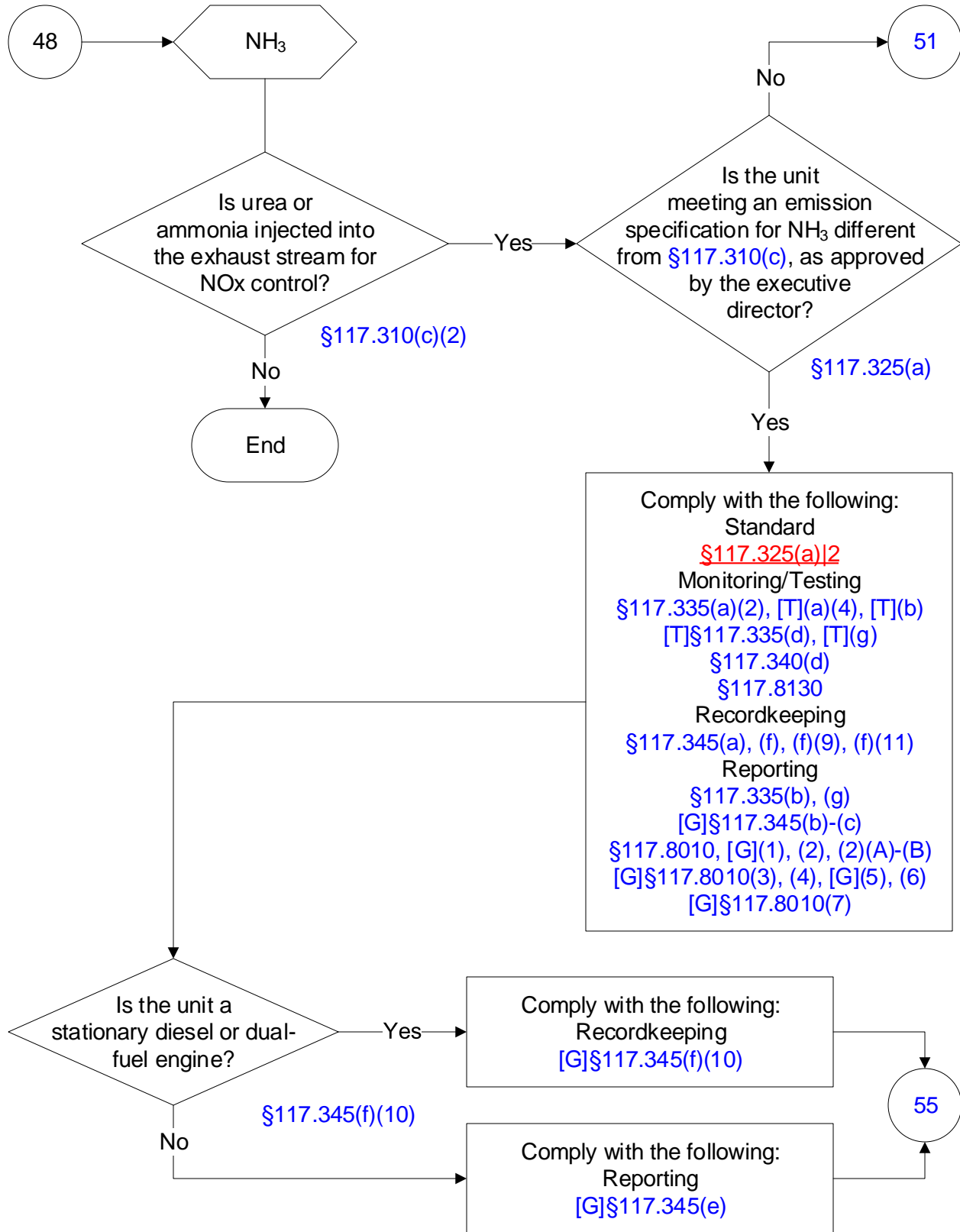

**Combustion Control at Major ICI Sources Division 3: Engines
Houston-Galveston-Brazoria Ozone Nonattainment Area
(32 of 36)**

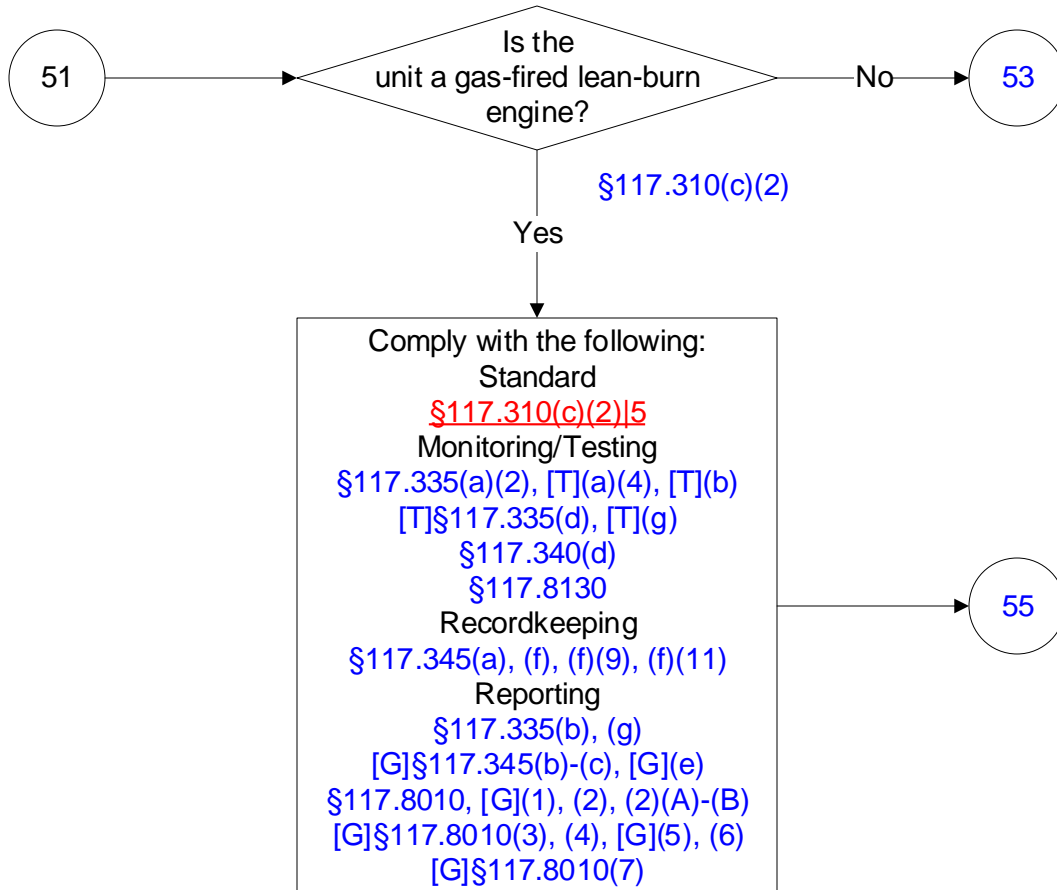

**Combustion Control at Major ICI Sources Division 3: Engines
Houston-Galveston-Brazoria Ozone Nonattainment Area
(33 of 36)**

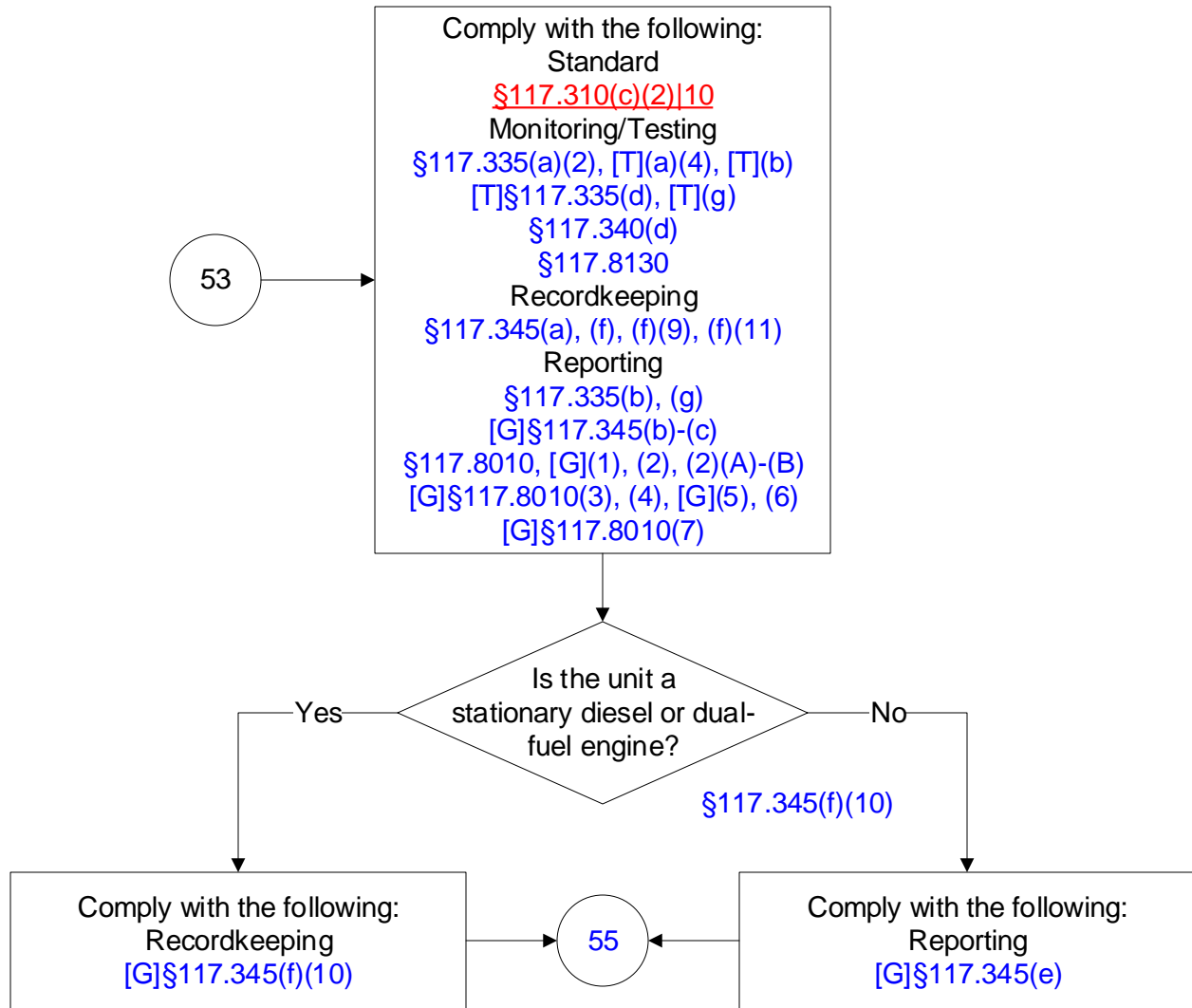

**Combustion Control at Major ICI Sources Division 3: Engines
Houston-Galveston-Brazoria Ozone Nonattainment Area
(34 of 36)**

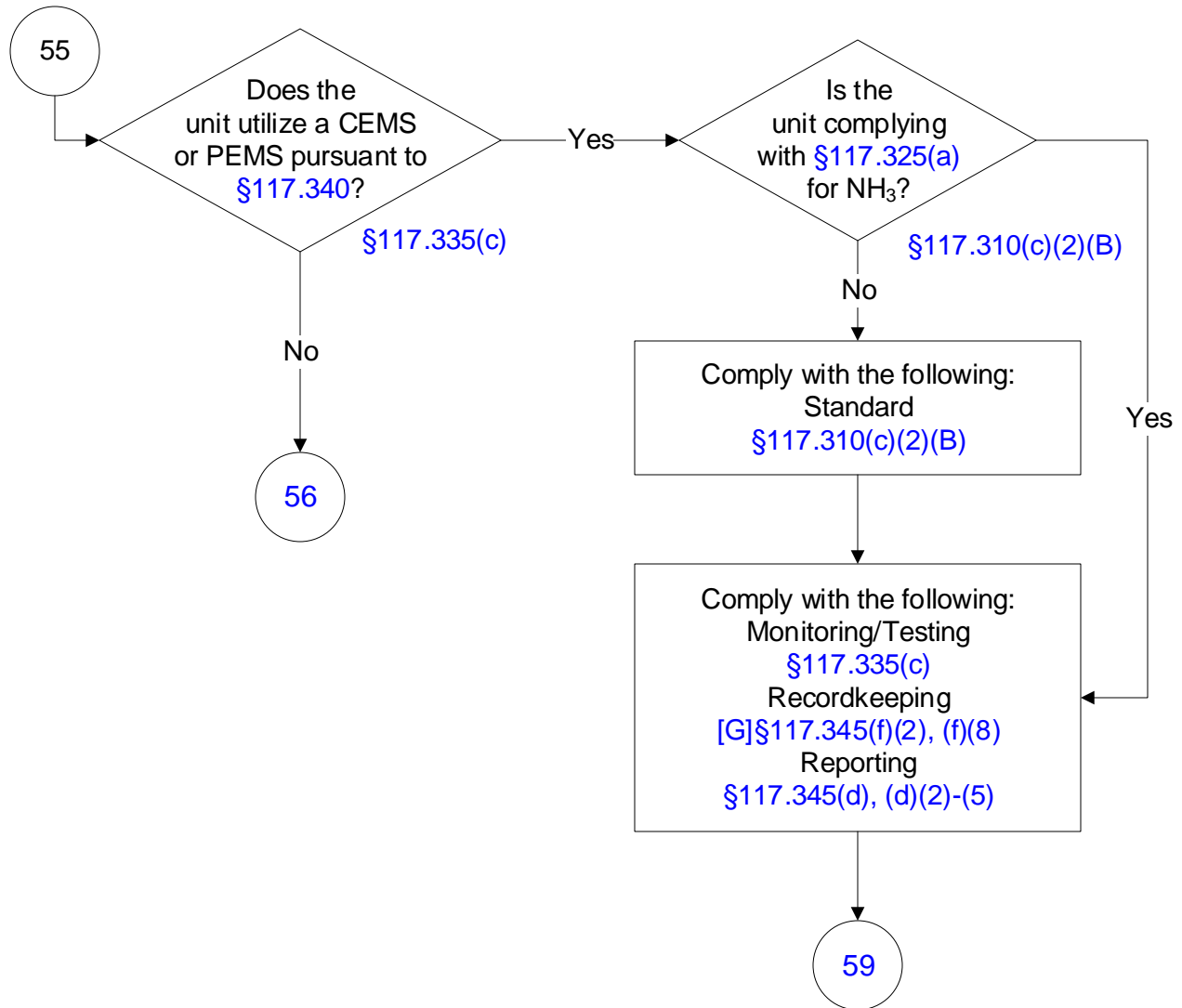

**Combustion Control at Major ICI Sources Division 3: Engines
Houston-Galveston-Brazoria Ozone Nonattainment Area
(35 of 36)**

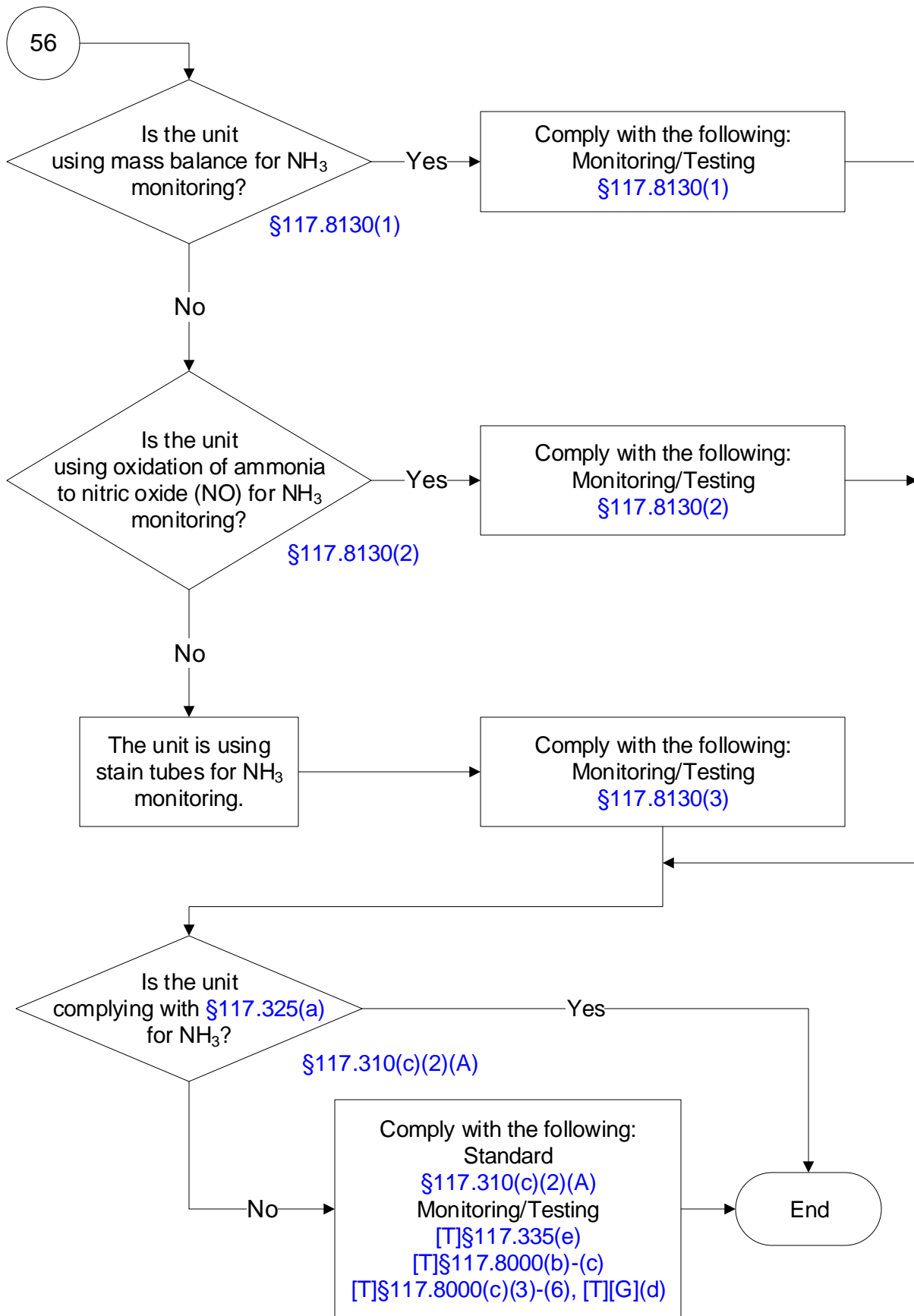

**Combustion Control at Major ICI Sources Division 3: Engines
Houston-Galveston-Brazoria Ozone Nonattainment Area
(36 of 36)**

