



**TCEQ EDWARDS AQUIFER PROTECTION PLAN
UST FACILITY PLAN**

**SUPER 365
2509 S. BELL BLVD.
CEDAR PARK, WILLIAMSON COUNTY, TEXAS
RN 102269818**

Prepared for:

**MICRO 290, LLC
13917 CAROLINA LANE
AUSTIN, TEXAS 78717**

APRIL 2023

Edwards Aquifer Application Cover Page

Texas Commission on Environmental Quality

Edwards Aquifer Application Cover Page

Our Review of Your Application

The Edwards Aquifer Program staff conducts an administrative and technical review of all applications. The turnaround time for administrative review can be up to 30 days as outlined in 30 TAC 213.4(e). Generally administrative completeness is determined during the intake meeting or within a few days of receipt. The turnaround time for technical review of an administratively complete Edwards Aquifer application is 90 days as outlined in 30 TAC 213.4(e). Please know that the review and approval time is directly impacted by the quality and completeness of the initial application that is received. In order to conduct a timely review, it is imperative that the information provided in an Edwards Aquifer application include final plans, be accurate, complete, and in compliance with [30 TAC 213](#).

Administrative Review

1. [Edwards Aquifer applications](#) must be deemed administratively complete before a technical review can begin. To be considered administratively complete, the application must contain completed forms and attachments, provide the requested information, and meet all the site plan requirements. The submitted application and plan sheets should be final plans. Please submit one full-size set of plan sheets with the original application, and half-size sets with the additional copies.

To ensure that all applicable documents are included in the application, the program has developed tools to guide you and web pages to provide all forms, checklists, and guidance. Please visit the below website for assistance: <http://www.tceq.texas.gov/field/eapp>.

2. This Edwards Aquifer Application Cover Page form (certified by the applicant or agent) must be included in the application and brought to the administrative review meeting.
3. Administrative reviews are scheduled with program staff who will conduct the review. Applicants or their authorized agent should call the appropriate regional office, according to the county in which the project is located, to schedule a review. The average meeting time is one hour.
4. In the meeting, the application is examined for administrative completeness. Deficiencies will be noted by staff and emailed or faxed to the applicant and authorized agent at the end of the meeting, or shortly after. Administrative deficiencies will cause the application to be deemed incomplete and returned.

An appointment should be made to resubmit the application. The application is re-examined to ensure all deficiencies are resolved. The application will only be deemed administratively complete when all administrative deficiencies are addressed.

5. If an application is received by mail, courier service, or otherwise submitted without a review meeting, the administrative review will be conducted within 30 days. The applicant and agent will be contacted with the results of the administrative review. If the application is found to be administratively incomplete, it can be retrieved from the regional office or returned by regular mail. If returned by mail, the regional office may require arrangements for return shipping.
6. If the geologic assessment was completed before October 1, 2004 and the site contains “possibly sensitive” features, the assessment must be updated in accordance with the *Instructions to Geologists* (TCEQ-0585 Instructions).

Technical Review

1. When an application is deemed administratively complete, the technical review period begins. The regional office will distribute copies of the application to the identified affected city, county, and groundwater conservation district whose jurisdiction includes the subject site. These entities and the public have 30 days to provide comments on the application to the regional office. All comments received are reviewed by TCEQ.
2. A site assessment is usually conducted as part of the technical review, to evaluate the geologic assessment and observe existing site conditions. The site must be accessible to our staff. The site boundaries should be

clearly marked, features identified in the geologic assessment should be flagged, roadways marked and the alignment of the Sewage Collection System and manholes should be staked at the time the application is submitted. If the site is not marked the application may be returned.

3. We evaluate the application for technical completeness and contact the applicant and agent via Notice of Deficiency (NOD) to request additional information and identify technical deficiencies. There are two deficiency response periods available to the applicant. There are 14 days to resolve deficiencies noted in the first NOD. If a second NOD is issued, there is an additional 14 days to resolve deficiencies. If the response to the second notice is not received, is incomplete or inadequate, or provides new information that is incomplete or inadequate, the application must be withdrawn or will be denied. Please note that because the technical review is underway, whether the application is withdrawn or denied **the application fee will be forfeited.**
4. The program has 90 calendar days to complete the technical review of the application. If the application is technically adequate, such that it complies with the Edwards Aquifer rules, and is protective of the Edwards Aquifer during and after construction, an approval letter will be issued. Construction or other regulated activity may not begin until an approval is issued.

Mid-Review Modifications

It is important to have final site plans prior to beginning the permitting process with TCEQ to avoid delays.

Occasionally, circumstances arise where you may have significant design and/or site plan changes after your Edwards Aquifer application has been deemed administratively complete by TCEQ. This is considered a “Mid-Review Modification”. Mid-Review Modifications may require redistribution of an application that includes the proposed modifications for public comment.

If you are proposing a Mid-Review Modification, two options are available:

- If the technical review has begun your application can be denied/withdrawn, your fees will be forfeited, and the plan will have to be resubmitted.
- TCEQ can continue the technical review of the application as it was submitted, and a modification application can be submitted at a later time.

If the application is denied/withdrawn, the resubmitted application will be subject to the administrative and technical review processes and will be treated as a new application. The application will be redistributed to the affected jurisdictions.

Please contact the regional office if you have questions. If your project is located in Williamson, Travis, or Hays County, contact TCEQ’s Austin Regional Office at 512-339-2929. If your project is in Comal, Bexar, Medina, Uvalde, or Kinney County, contact TCEQ’s San Antonio Regional Office at 210-490-3096

Please fill out all required fields below and submit with your application.

1. Regulated Entity Name: Super 365				2. Regulated Entity No.: 102269818					
3. Customer Name: Micro 290, LLC				4. Customer No.: TBD					
5. Project Type: (Please circle/check one)	<input checked="" type="checkbox"/> New	Modification		Extension	Exception				
6. Plan Type: (Please circle/check one)	WPAP	CZP	SCS	<input checked="" type="checkbox"/> UST	AST	EXP	EXT	Technical Clarification	Optional Enhanced Measures
7. Land Use: (Please circle/check one)	Residential		<input checked="" type="checkbox"/> Non-residential		8. Site (acres):		0.319		
9. Application Fee:	\$650.00		10. Permanent BMP(s):			NA-no new IC, see engineer comments			
11. SCS (Linear Ft.):	NA		12. AST/UST (No. Tanks):			1 UST			
13. County:	Williamson		14. Watershed:			Turkey Creek-Brushy Creek			

Application Distribution

Instructions: Use the table below to determine the number of applications required. One original and one copy of the application, plus additional copies (as needed) for each affected incorporated city, county, and groundwater conservation district are required. Linear projects or large projects, which cross into multiple jurisdictions, can require additional copies. Refer to the “Texas Groundwater Conservation Districts within the EAPP Boundaries” map found at:

http://www.tceq.texas.gov/assets/public/compliance/field_ops/eapp/EAPP%20GWCD%20map.pdf

For more detailed boundaries, please contact the conservation district directly.

Austin Region			
County:	Hays	Travis	Williamson
Original (1 req.)	—	—	<u> </u> X <u> </u>
Region (1 req.)	—	—	<u> </u> X <u> </u>
County(ies)	—	—	<u> </u> X <u> </u>
Groundwater Conservation District(s)	<u> </u> Edwards Aquifer Authority <u> </u> Barton Springs/ Edwards Aquifer <u> </u> Hays Trinity <u> </u> Plum Creek	<u> </u> Barton Springs/ Edwards Aquifer	NA
City(ies) Jurisdiction	<u> </u> Austin <u> </u> Buda <u> </u> Dripping Springs <u> </u> Kyle <u> </u> Mountain City <u> </u> San Marcos <u> </u> Wimberley <u> </u> Woodcreek	<u> </u> Austin <u> </u> Bee Cave <u> </u> Pflugerville <u> </u> Rollingwood <u> </u> Round Rock <u> </u> Sunset Valley <u> </u> West Lake Hills	<u> </u> Austin <u> </u> X <u> </u> Cedar Park <u> </u> Florence <u> </u> Georgetown <u> </u> Jerrell <u> </u> Leander <u> </u> Liberty Hill <u> </u> Pflugerville <u> </u> Round Rock

San Antonio Region					
County:	Bexar	Comal	Kinney	Medina	Uvalde
Original (1 req.)	—	—	—	—	—
Region (1 req.)	—	—	—	—	—
County(ies)	—	—	—	—	—
Groundwater Conservation District(s)	<u> </u> Edwards Aquifer Authority <u> </u> Trinity-Glen Rose	<u> </u> Edwards Aquifer Authority	<u> </u> Kinney	<u> </u> EAA <u> </u> Medina	<u> </u> EAA <u> </u> Uvalde
City(ies) Jurisdiction	<u> </u> Castle Hills <u> </u> Fair Oaks Ranch <u> </u> Helotes <u> </u> Hill Country Village <u> </u> Hollywood Park <u> </u> San Antonio (SAWS) <u> </u> Shavano Park	<u> </u> Bulverde <u> </u> Fair Oaks Ranch <u> </u> Garden Ridge <u> </u> New Braunfels <u> </u> Schertz	NA	<u> </u> San Antonio ETJ (SAWS)	NA

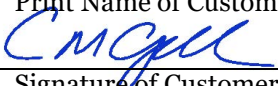
I certify that to the best of my knowledge, that the application is complete and accurate. This application is hereby submitted to TCEQ for administrative review and technical review.	
Chad M. Copeland, P.G.	
Print Name of Customer/Authorized Agent	4/24/2023
	Date
Signature of Customer/Authorized Agent	Date

FOR TCEQ INTERNAL USE ONLY			
Date(s) Reviewed:		Date Administratively Complete:	
Received From:		Correct Number of Copies:	
Received By:		Distribution Date:	
EAPP File Number:		Complex:	
Admin. Review(s) (No.):		No. AR Rounds:	
Delinquent Fees (Y/N):		Review Time Spent:	
Lat./Long. Verified:		SOS Customer Verification:	
Agent Authorization Complete/Notarized (Y/N):		Fee Check:	Payable to TCEQ (Y/N):
Core Data Form Complete (Y/N):			Signed (Y/N):
Core Data Form Incomplete Nos.:			Less than 90 days old (Y/N):

Underground Storage Tank Facility Plan Application – Checklist
TCEQ-0583

Underground Storage Tank Facility Plan Checklist

Edwards Aquifer Application Cover Page (TCEQ-20705)

General Information Form (TCEQ-0587)

Attachment A - Road Map

Attachment B - USGS / Edwards Recharge Zone Map

Attachment C - Project Description

Exception **Geologic Assessment Form (TCEQ-0585)**

Attachment A - Geologic Assessment Table (TCEQ-0585-Table)

Attachment B - Stratigraphic Column

Attachment C - Site Geology

Attachment D - Site Geologic Map(s)

Underground Storage Tank Facility Plan (TCEQ-0583)

Attachment A - Detailed Narrative of UST Facility

Attachment B – Manufacturer Information for Tanks

Attachment C - Alternative Design and Protection Method for Tanks (if proposed)

Attachment D – Manufacturer Information for Piping

Attachment E - Alternative Design and Protection Method for Piping (if proposed)

Attachment F - Tertiary Containment Method

Attachment G - Exception to the Geologic Assessment (if requested)

Attachment H - Profile Drawing(s)

Attachment I - Initial and Continuing Training

Attachment J - Release Detection Maintenance

Site Plan

Temporary Stormwater Section (TCEQ-0602)

Attachment A - Spill Response Actions

Attachment B - Potential Sources of Contamination

Attachment C - Sequence of Major Activities

Attachment D - Temporary Best Management Practices and Measures

Attachment E - Request to Temporarily Seal a Feature (if requested)

Attachment F - Structural Practices

Attachment G - Drainage Area Map

Attachment H - Temporary Sediment Pond(s) Plans and Calculations

Attachment I - Inspection and Maintenance for BMPs

Attachment J - Schedule of Interim and Permanent Soil Stabilization Practices

Agent Authorization Form (TCEQ-0599), if application submitted by agent

Application Fee Form (TCEQ-0574)

Check Payable to the “Texas Commission on Environmental Quality”

Core Data Form (TCEQ-10400)

Per Tax Records, I.C. Was constructed in 1971 and converted to fuel sales in 1993. The property has been surveyed and I.C. Calculated per the related plan sheet. The proposed Construction entails tank replacement and new piping to the Multiple Product Dispensers shown on the plan. Permanent Storm is not included in this plan due to the construction of the I.C. Pre-Dating the Rule for this project. As shown the I.C. will not change as a result of the Tank Construction.

Water Pollution Abatement Plan Checklist

- **Edwards Aquifer Application Cover Page (TCEQ-20705)**
- **General Information Form (TCEQ-0587)**
 - Attachment A - Road Map
 - Attachment B - USGS / Edwards Recharge Zone Map
 - Attachment C - Project Description
- **Geologic Assessment Form (TCEQ-0585)**
 - Attachment A - Geologic Assessment Table (TCEQ-0585-Table)
 - Attachment B - Stratigraphic Column
 - Attachment C - Site Geology
 - Attachment D - Site Geologic Map(s)
- **Water Pollution Abatement Plan Application Form (TCEQ-0584)**
 - Attachment A - Factors Affecting Surface Water Quality
 - Attachment B - Volume and Character of Stormwater
 - Attachment C - Suitability Letter from Authorized Agent (if OSSF is proposed)
 - Attachment D - Exception to the Required Geologic Assessment (if requested)
 - Site Plan
- **Temporary Stormwater Section (TCEQ-0602)**
 - Attachment A - Spill Response Actions
 - Attachment B - Potential Sources of Contamination
 - Attachment C - Sequence of Major Activities
 - Attachment D - Temporary Best Management Practices and Measures
 - Attachment E - Request to Temporarily Seal a Feature (if requested)
 - Attachment F - Structural Practices
 - Attachment G - Drainage Area Map
 - Attachment H - Temporary Sediment Pond(s) Plans and Calculations
 - Attachment I - Inspection and Maintenance for BMPs
 - Attachment J - Schedule of Interim and Permanent Soil Stabilization Practices
- **Permanent Stormwater Section (TCEQ-0600)**
 - Attachment A - 20% or Less Impervious Cover Waiver (if requested for multi-family, school, or small business site)
 - Attachment B - BMPs for Upgradient Stormwater
 - Attachment C - BMPs for On-site Stormwater
 - Attachment D - BMPs for Surface Streams
 - Attachment E - Request to Seal Features (if sealing a feature)
 - Attachment F - Construction Plans
 - Attachment G - Inspection, Maintenance, Repair and Retrofit Plan
 - Attachment H - Pilot-Scale Field Testing Plan (if proposed)
 - Attachment I - Measures for Minimizing Surface Stream Contamination

- **Agent Authorization Form (TCEQ-0599), if application submitted by agent**
- **Application Fee Form (TCEQ-0574)**
- **Check Payable to the “Texas Commission on Environmental Quality”**
- **Core Data Form (TCEQ-10400)**

General Information Form
TCEQ-0587

General Information Form

Texas Commission on Environmental Quality

For Regulated Activities on the Edwards Aquifer Recharge and Transition Zones and Relating to 30 TAC §213.4(b) & §213.5(b)(2)(A), (B) Effective June 1, 1999

To ensure that the application is administratively complete, confirm that all fields in the form are complete, verify that all requested information is provided, consistently reference the same site and contact person in all forms in the application, and ensure forms are signed by the appropriate party.

Note: Including all the information requested in the form and attachments contributes to more streamlined technical reviews.

Signature

To the best of my knowledge, the responses to this form accurately reflect all information requested concerning the proposed regulated activities and methods to protect the Edwards Aquifer. This **General Information Form** is hereby submitted for TCEQ review. The application was prepared by:

Print Name of Customer/Agent: Chad M. Copeland, P.G., PWS

Date: 4/24/2023

Signature of Customer/Agent:



Project Information

1. Regulated Entity Name: Super 365
2. County: Williamson County
3. Stream Basin: Brazos
4. Groundwater Conservation District (If applicable): NA
5. Edwards Aquifer Zone:
 Recharge Zone
 Transition Zone
6. Plan Type:
 WPAP (NA, predates EAPP Rules, no new IC proposed) AST
 SCS UST
 Modification Exception Request (GA & WPAP)

7. Customer (Applicant):

Contact Person: Rafiq Karediya

Entity: Micro 290, LLC

Mailing Address: 13917 Carolina Lane

City, State: Austin, Texas

Zip: 78717

Telephone: (512) 850-3331

FAX: _____

Email Address: rafiqu@aol.com

8. Agent/Representative (If any):

Contact Person: Chad M. Copeland, P.G.

Entity: Ranger Environmental Services, LLC

Mailing Address: P.O. Box 201179

City, State: Austin, Texas

Zip: 78720

Telephone: (512) 335-1785x124

FAX: (512) 335-0527

Email Address: chad@rangerenv.com

9. Project Location:

- The project site is located inside the city limits of Cedar Park, Texas.
- The project site is located outside the city limits but inside the ETJ (extra-territorial jurisdiction) of _____.
- The project site is not located within any city's limits or ETJ.

10. The location of the project site is described below. The description provides sufficient detail and clarity so that the TCEQ's Regional staff can easily locate the project and site boundaries for a field investigation.

The site is located at 2509 S. Bell Blvd., Cedar Park (Williamson County), Texas.

11. **Attachment A – Road Map.** A road map showing directions to and the location of the project site is attached. The project location and site boundaries are clearly shown on the map.
12. **Attachment B - USGS / Edwards Recharge Zone Map.** A copy of the official 7 ½ minute USGS Quadrangle Map (Scale: 1" = 2000') of the Edwards Recharge Zone is attached. The map(s) clearly show:
- Project site boundaries.
 - USGS Quadrangle Name(s).
 - Boundaries of the Recharge Zone (and Transition Zone, if applicable).
 - Drainage path from the project site to the boundary of the Recharge Zone.
13. **The TCEQ must be able to inspect the project site or the application will be returned.** Sufficient survey staking is provided on the project to allow TCEQ regional staff to locate the boundaries and alignment of the regulated activities and the geologic or manmade features noted in the Geologic Assessment.

Survey staking will be completed by this date: Staking will not be in place due to the site being previously developed.

14. **Attachment C – Project Description.** Attached at the end of this form is a detailed narrative description of the proposed project. The project description is consistent throughout the application and contains, at a minimum, the following details:

- Area of the site
- Offsite areas
- Impervious cover
- Permanent BMP(s)
- Proposed site use
- Site history
- Previous development
- Area(s) to be demolished

15. Existing project site conditions are noted below:

- Existing commercial site
- Existing industrial site
- Existing residential site
- Existing paved and/or unpaved roads
- Undeveloped (Cleared)
- Undeveloped (Undisturbed/Uncleared)
- Other: _____

Prohibited Activities

16. I am aware that the following activities are prohibited on the Recharge Zone and are not proposed for this project:

- (1) Waste disposal wells regulated under 30 TAC Chapter 331 of this title (relating to Underground Injection Control);
- (2) New feedlot/concentrated animal feeding operations, as defined in 30 TAC §213.3;
- (3) Land disposal of Class I wastes, as defined in 30 TAC §335.1;
- (4) The use of sewage holding tanks as parts of organized collection systems; and
- (5) New municipal solid waste landfill facilities required to meet and comply with Type I standards which are defined in §330.41(b), (c), and (d) of this title (relating to Types of Municipal Solid Waste Facilities).
- (6) New municipal and industrial wastewater discharges into or adjacent to water in the state that would create additional pollutant loading.

17. I am aware that the following activities are prohibited on the Transition Zone and are not proposed for this project:

- (1) Waste disposal wells regulated under 30 TAC Chapter 331 (relating to Underground Injection Control);
- (2) Land disposal of Class I wastes, as defined in 30 TAC §335.1; and
- (3) New municipal solid waste landfill facilities required to meet and comply with Type I standards which are defined in §330.41 (b), (c), and (d) of this title.

Administrative Information

18. The fee for the plan(s) is based on:

- For a Water Pollution Abatement Plan or Modification, the total acreage of the site where regulated activities will occur.
- For an Organized Sewage Collection System Plan or Modification, the total linear footage of all collection system lines.
- For a UST Facility Plan or Modification or an AST Facility Plan or Modification, the total number of tanks or piping systems.
- A request for an exception to any substantive portion of the regulations related to the protection of water quality.
- A request for an extension to a previously approved plan.

19. Application fees are due and payable at the time the application is filed. If the correct fee is not submitted, the TCEQ is not required to consider the application until the correct fee is submitted. Both the fee and the Edwards Aquifer Fee Form have been sent to the Commission's:

- TCEQ cashier
- Austin Regional Office (for projects in Hays, Travis, and Williamson Counties)
- San Antonio Regional Office (for projects in Bexar, Comal, Kinney, Medina, and Uvalde Counties)

20. Submit one (1) original and one (1) copy of the application, plus additional copies as needed for each affected incorporated city, groundwater conservation district, and county in which the project will be located. The TCEQ will distribute the additional copies to these jurisdictions. The copies must be submitted to the appropriate regional office.

21. No person shall commence any regulated activity until the Edwards Aquifer Protection Plan(s) for the activity has been filed with and approved by the Executive Director.

ATTACHMENT A

Road Map



Legend
 Property Boundary



NOTES:

1. ALL PROPERTY BOUNDARIES ARE APPROXIMATE AND NOT TO BE USED FOR CONSTRUCTION PURPOSES.

2. IMAGERY IS UTILIZED AS A POINT OF REFERENCE; SITE DETAILS AND SCALE ARE APPROXIMATE.

3. AERIAL IMAGES ARE ARCHIVED AND MAY NOT REFLECT CURRENT CONDITIONS.

Sources: Esri, HERE, Garmin, USGS, Intermap, INCREMENT P, NRCan, Esri Japan, METI, Esri China (Hong Kong), Esri Korea, Esri (Thailand), NGCC, (c) OpenStreetMap contributors, and the GIS User Community

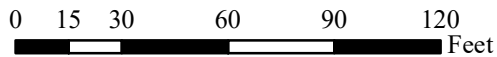

1:650

Road Map

2509 S. Bell Blvd. Cedar Park, TX 78613
Ranger No. 6700

ATTACHMENT B

USGS / Edwards Recharge Zone Map

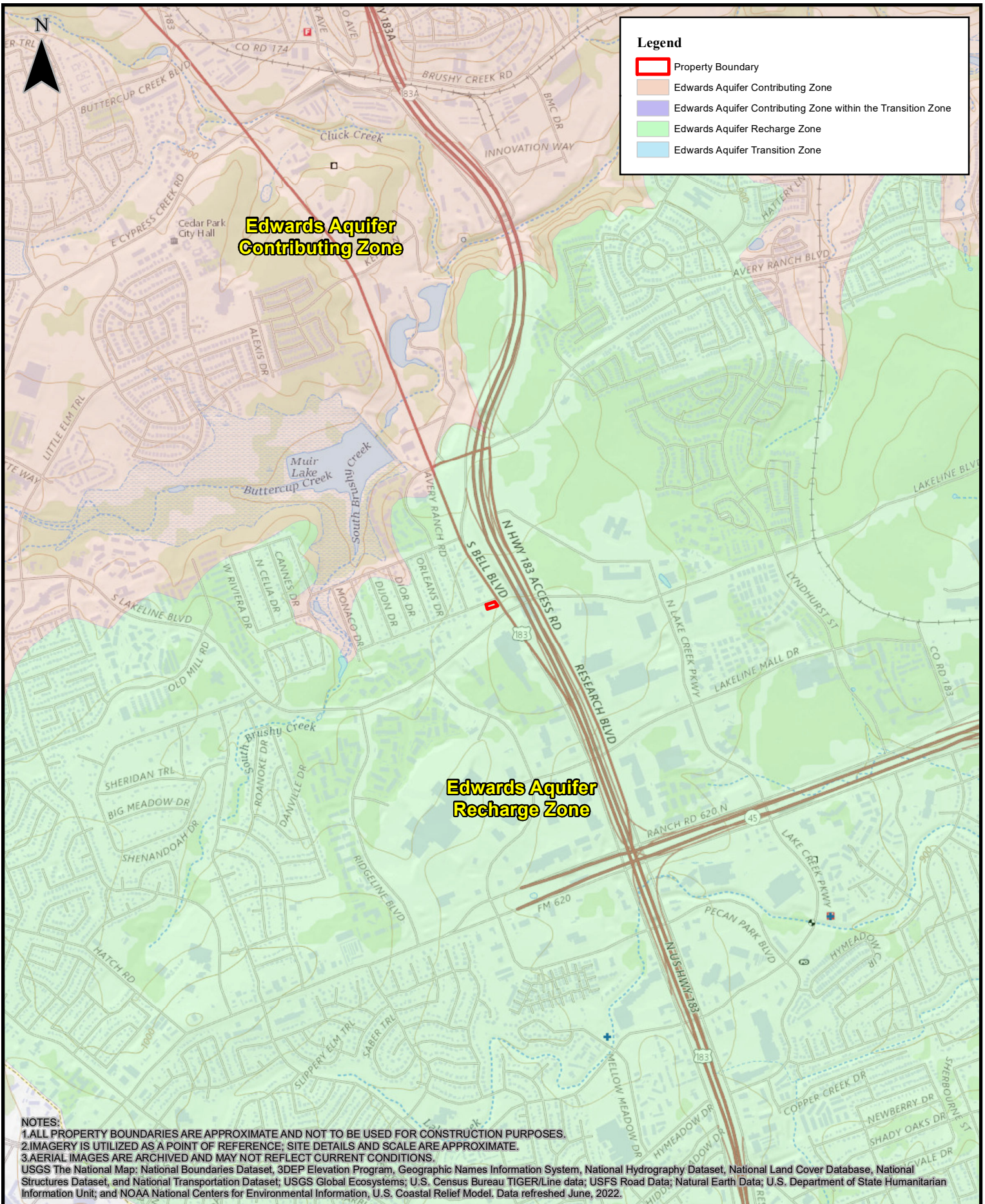

Legend

- Property Boundary
- Edwards Aquifer Contributing Zone
- Edwards Aquifer Contributing Zone within the Transition Zone
- Edwards Aquifer Recharge Zone
- Edwards Aquifer Transition Zone

**Edwards Aquifer
Contributing Zone**

**Edwards Aquifer
Recharge Zone**

NOTES:
 1. ALL PROPERTY BOUNDARIES ARE APPROXIMATE AND NOT TO BE USED FOR CONSTRUCTION PURPOSES.
 2. IMAGERY IS UTILIZED AS A POINT OF REFERENCE; SITE DETAILS AND SCALE ARE APPROXIMATE.
 3. AERIAL IMAGES ARE ARCHIVED AND MAY NOT REFLECT CURRENT CONDITIONS.
 USGS The National Map: National Boundaries Dataset, 3DEP Elevation Program, Geographic Names Information System, National Hydrography Dataset, National Land Cover Database, National Structures Dataset, and National Transportation Dataset; USGS Global Ecosystems; U.S. Census Bureau TIGER/Line data; USFS Road Data; Natural Earth Data; U.S. Department of State Humanitarian Information Unit; and NOAA National Centers for Environmental Information, U.S. Coastal Relief Model. Data refreshed June, 2022.



0 600 1,200 2,400 3,600 4,800 Feet

1:24,000

Topographic Map (Jollyville Quadrangle)

2509 S. Bell Blvd. Cedar Park, TX 78613
 Ranger No. 6700

ATTACHMENT C

Project Description

PROJECT DESCRIPTION

The subject site is located at 2509 S. Bell Blvd., Cedar Park, Williamson County, Texas. The site is located within the Edwards Aquifer Recharge Zone. The proposed commercial project is located at an existing gas station that was constructed before Edwards Aquifer rules were established. Per Tax Records, I.C. was constructed in 1971 and converted to fuel sales in 1993. The property has been surveyed and I.C. calculated per the related plan sheet (attached). The proposed construction entails tank replacement and new piping to the multiple product dispensers shown on the plan. Permanent Storm is not included in this plan due to the construction of the I.C. Pre-Dating the Rule for this project. As shown, the I.C. will not change as a result of the tank construction.

The areas surrounding the subject site supports mixed commercial and residential properties.

The proposed underground storage tank system will include a 20,000-gallon Modern Glasteel steel triple-wall tank containing gasoline and diesel (UL 58, UL 1746). The UST will be compartmentalized with the following storage capacity: 5,000-gallons gasoline, 5,000-gallons gasoline, and 10,000-gallons diesel. The corresponding underground storage tank sumps proposed are Bravo collar-mount tank sumps. Associated with this tank will be two (2) Gilbarco 700 S dispensers along with Dualoy 3000/LCX double-walled fiberglass piping.

The tank will be equipped with FE Petro submersible pumps (1.5 hp) for each compartment. Overfill prevention for each tank compartment will be provided by a valve assembly which will be installed in the tank below the vapor recovery fitting and will be set to shut off flow into the tank when the volume of liquid in the tank reaches no more than 95% of the tank capacity.

Product piping will be U.L. listed Dualoy 3000/LCX double wall fiberglass-reinforced plastic piping. Dualoy 3000/LCX pipe is UL 971 listed. Vent lines will be 2-inch diameter double-wall pipe. Under each dispenser, for each product grade, there will be a shear valve mounted to a rigid framework and installed at the dispenser island surface level to assure automatic shut-off of product flow during impact or fire emergencies. In addition, FLEX-ING flexible connectors will be installed at both ends of each product line in isolation sumps to connect to the dispenser unit and submersible pump.

Corrosion protection for the metallic components of the underground storage systems will be provided by electrical isolation. The submersible pump housings and pump-end flexible connectors will be installed within a Bravo Collar-Mount tank sump, which will provide isolation from the backfill material while also providing containment for any leaks from these components. The dispenser-end flexible connectors will be similarly isolated by enclosure within Bravo Economy B1000 Series under dispenser sumps.

The proposed tank and piping will be monitored for leaks by means of inventory control, tank monitor CSLD release detection software, sump and interstitial leak detection, and electronic line leak detection. The tank will be equipped with a liquid discrimination sensor which will be installed adjacent to the submersible pumps in the sumps and in all dispenser sumps. The tank will also be equipped with an electronic automatic tank gauging inventory probe for inventory of the product volume in the tank.

The controller will be equipped with Continuous Statistical Leak Detection to meet TCEQ release detection requirements. Each product piping line will be equipped with mechanical line leak detection. The probes and sensors from the tank will be connected to a Veeder-Root 450 TLS programmable control unit to be located in the store building. The tank interstitial is monitored with a Veeder Root interstitial sensor which will set off an alarm if liquid enters the tank interstitial. This central monitoring unit is designed to provide visual and audible alarms when hydrocarbon liquids or water is detected.

EXISTING IMPERVIOUS COVER = 10,460 SF
REMAINS UNCHANGED BY THIS PLAN

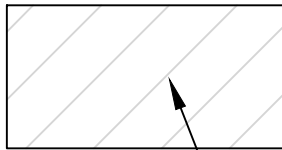

EXISTING IMPERVIOUS COVER
CALCULATION

PIPE CHASE LOCATIONS

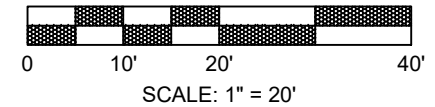
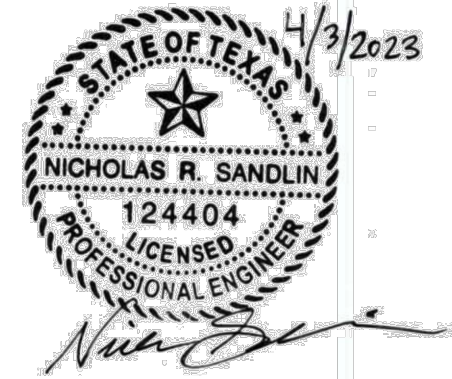

IF DRAWING BAR DOES NOT MEASURE 2"
THIS PRINT IS NOT TO SCALE



WARNING !!!! CONTRACTOR TO FIELD VERIFY
ALL EXIST. UTILITIES VERTICALLY AND
HORIZONTALLY PRIOR TO CONSTRUCTION.
THE CONTRACTOR IS TO CONTACT ENGINEER
IF ANY EXISTING UTILITY INFORMATION
DIFFERS FROM DATA SHOWN IN THE PLANS.
CALL 811 BEFORE YOU DIG.

ENGINEERING | CONSULTING
SANDLIN
SERVICES, LLC

TBPELS FIRM #21356
4501 WHISPERING VALLEY DRIVE UNIT 27 AUSTIN, TX 78727

SITE LAYOUT PLAN

BELL BLVD C-STORE TCEQ WPAP

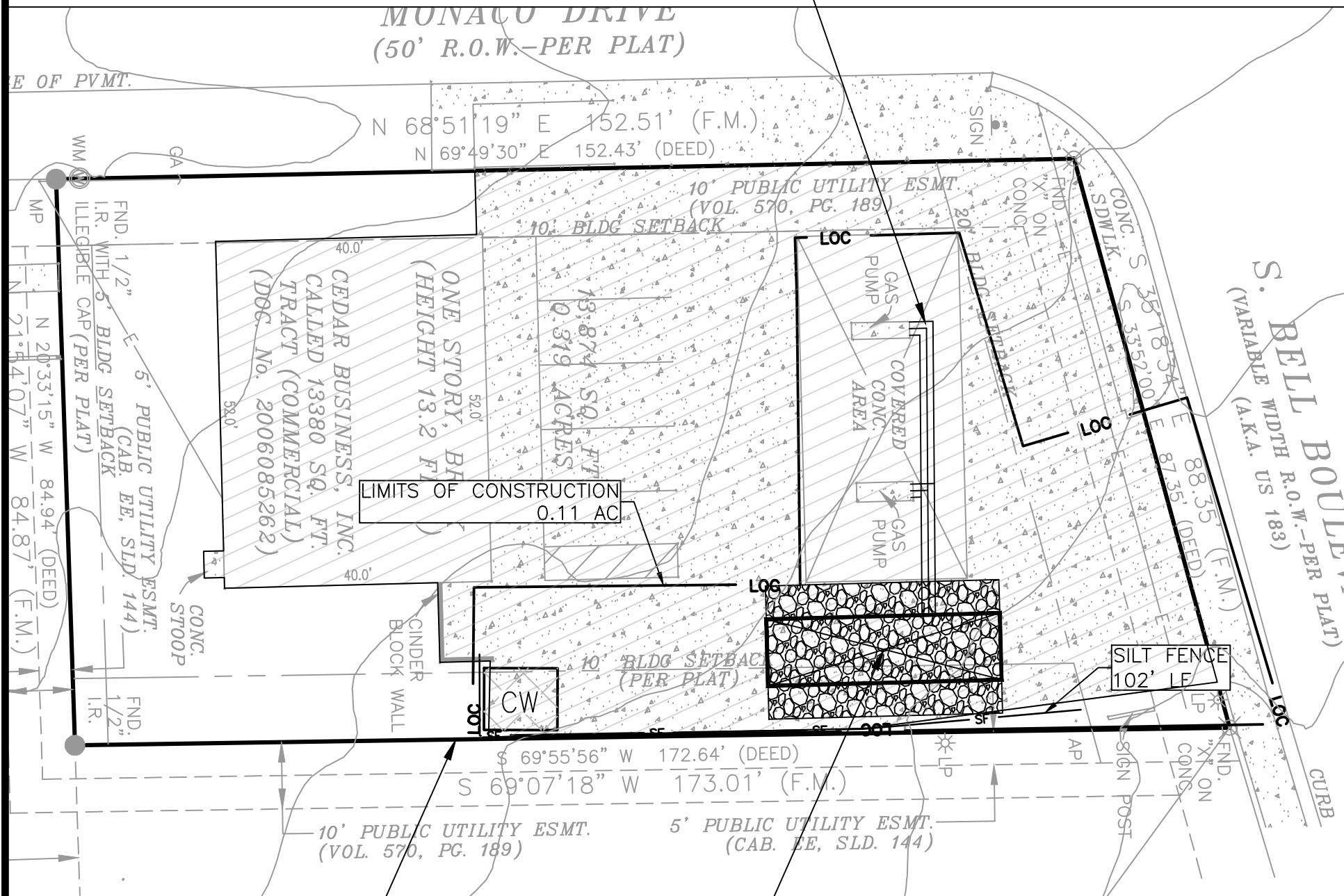

UNDERGROUND STORAGE TANK
REFER TO TANK SPECIFICATION

PROPERTY BOUNDARY

REV. NO.	BY	DATE	REVISION DESCRIPTION

SHEET
1
OF 1

Geologic Assessment
TCEQ-0585

Geologic Assessment

REGULATED ENTITY NAME: Super 365

TYPE OF PROJECT: x WPAP AST SCS X UST

LOCATION OF PROJECT: X Recharge Zone Transition Zone Contributing Zone
within the
Transition Zone

Ranger Environmental Services, Inc. (Ranger) field personnel attempted to perform the required Geologic Assessment at the aforementioned facility located at 2509 S. Bell Blvd., Cedar Park, Williamson County, Texas on March 20, 2023. During the site visit, it was observed that the site has been previously developed and appeared to operate as a retail fueling facility and convenience store. The site was noted to be less than 0.5 acres in size and is mostly impervious cover. It appears that the site pre-dated the Edwards rule at the time of original development.

Therefore, based on the site currently being developed with mostly impervious cover and the fact that the native soils are not exposed, it is requested that an exception to the Geologic Assessment requirement be granted.

To the best of my knowledge, the responses to this form accurately reflect all information requested concerning the proposed regulated activities and methods to protect the Edwards Aquifer. My signature certifies that I am qualified as a geologist as defined by 30 TAC Chapter 213.

Chad M. Copeland, PG, PWS

512/335-1785
Telephone

512/335-0527
Fax

03/20/2023
Date



Signature of Geoscientist

Representing: Ranger Environmental Services, LLC
(Name of Company)

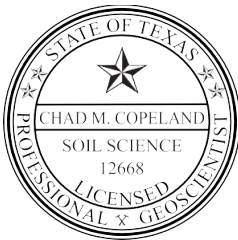

03/20/2023

Underground Storage Tank Facility Plan Application
TCEQ-0583

Underground Storage Tank Facility Plan Application

Texas Commission on Environmental Quality

for Storage on the Edwards Aquifer Recharge and Transition Zones and Relating to 30 TAC §213.5(d), Effective June 1, 1999

To ensure that the application is administratively complete, confirm that all fields in the form are complete, verify that all requested information is provided, consistently reference the same site and contact person in all forms in the application, and ensure forms are signed by the appropriate party.

Note: Including all the information requested in the form and attachments contributes to more streamlined technical reviews.

Signature

To the best of my knowledge, the responses to this form accurately reflect all information requested concerning the proposed regulated activities and methods to protect the Edwards Aquifer. All components used for this facility are U.L. listed or certified by a 3rd party and are compatible and will function pursuant to 30 TAC §213.5(d) and 30 TAC Chapter 334 Subchapter C. This **Underground Storage Tank Facility Plan Application** is hereby submitted for TCEQ review and Executive Director approval. The application was prepared by:

Print Name of Customer/Agent: Chad M. Copeland, P.G., PWS

Date: 4/24/2023

Signature of Customer/Agent:



Regulated Entity Name: Super 365

Underground Storage Tank (UST) System Information

- Attachment A – Detailed Narrative of UST Facility.** A detailed narrative description of the proposed UST Facility is attached. Note: Example descriptions are provided in the instructions (TCEQ-0583-Instructions)
- Tanks and substance to be stored:

Table 1 - Tanks and Substances Stored

<i>UST Number</i>	<i>Size(Gallons)</i>	<i>Substance to be Stored</i>	<i>Double-wall Tank Material</i>
1	20,000	10,000 regular gasoline, 5,000 premium gasoline, 5,000 diesel	Glaesteel III Triple-wall tank (Modern Welding)
2			
3			
4			
5			

3. Tanks:

- Attachment B – Manufacturer Information for Tanks.** New or replacement systems for the underground storage of static hydrocarbons or hazardous substances must be double-walled or provide an equivalent method of protection approved by the executive director. Tanks must comply with technical standards as required by 30 TAC 334.45(b) relating to technical standards for new tanks. Manufacturer information is attached.
- Attachment C – Alternative Design and Protection Method for Tanks.** Information required by 30 TAC 334.43, relating to variances and alternative procedures is attached.

4. Piping:

- Attachment D – Manufacturer Information for Piping.** Piping must comply with technical standards as required by 30 TAC 334.45(c) relating to technical standards for new piping. Manufacturer information is attached.
- Attachment E – Alternative Design and Protection Method for Piping.** Information required by 30 TAC 334.43, relating to variances and alternative procedures is attached.

5. Any new underground storage tank system that does not incorporate a method for tertiary containment shall be located a minimum horizontal distance of 150 feet from any domestic, industrial, irrigation, or public water supply well, or other sensitive feature as required by 30 TAC §213.5(d)(1)(B).
- The UST system(s) will not be installed within 150 feet of a domestic, industrial, irrigation, or public water supply well, or other sensitive feature.
 - Attachment F - Tertiary Containment Method.** The UST system(s) will be required to have tertiary containment provided. A description of the method proposed to provide tertiary containment is attached.

6. Corrosion protection equipment to be installed or type of non-corrodible materials:

Table 2 - Corrosion Protection

<i>Equipment</i>	<i>Corrosion Protection (Method)</i>
Tanks	Modern Glasteel Triple Wall Tank
Product Delivery Piping	Dualoy 3000/LCX Fiberglass Piping
Vapor Recovery Piping	NA
Submersible Pumps	Isolated in sump
Flex Connector (dispenser end)	Isolated in sump
Flex Connector (pump end)	Isolated in sump
Riser	dielectric tape wrap

7. Overfill protection equipment to be installed:
- Overfill prevention restrictor positioned at 90% capacity.
 - Overfill prevention valve positioned at 95% capacity.
 - Overfill audible and visual alarm positioned at 90% capacity.
8. Methods for detecting leaks in the inside wall of a double-walled system must be included in the facility's design and construction. The leak detection system must provide continuous monitoring of the system and must be capable of immediately alerting the system's owner of possible leakages. Release detection equipment to be installed: (Check all that apply)
- Central on-site monitor
 - Interstitial tank probes
 - Automatic tank gauge
 - Pump/manway sump probes
 - Observation well probes
 - Mechanical line leak detectors (for pressurized lines only)
 - Automatic (electronic) line leak detectors

Excavation and Backfill

9. The depth of the tank excavation will be sufficient to accommodate piping fall requirements, tank diameter, bedding, and a minimum cover of three (3) feet [30 TAC §334.46].
- The depth of the tank excavation will be 15-16 feet.
10. The minimum thickness of the tank bedding will conform to 30 TAC §334.46(a)(5)(C and D).
- The tank bedding thickness will be 12 inches.

11. The material to be used as backfill will conform to 30 TAC §334.46(a)(5)(A and B) and will consist of:
- Clean washed non-corrosive sand
 - Pea gravel
 - Crushed rock
 - Other: _____
12. The slope of the product delivery line(s) will conform to 30 TAC §334.46(c)(2) and will be 1/8 (1/8" per foot minimum).

Site Plan Requirements

Items 13 - 24 must be included on the Site Plan.

13. The Site Plan must have a minimum scale of 1" = 400'.
Site Plan Scale: 1" = 20'.
14. 100-year floodplain boundaries:
- The 100-year floodplain boundaries are based on the following specific (including date of material) source(s): FEMA's National Flood Hazard Layer Viewer (2019)
 - Some part(s) of the project site is located within the 100-year floodplain. The floodplain is shown and labeled.
 - No part of the project site is located within the 100-year floodplain.
15. The layout of the development is shown with existing and finished contours at appropriate, but not greater than ten-foot contour intervals. Show lots, recreation centers, buildings, roads, etc.
- The layout of the development is shown with existing contours. Finished topographic contours will not differ from the existing topographic configuration and are not shown.
16. All known wells (oil, water, unplugged, capped and/or abandoned, test holes, etc.):
- There are 0(#) wells present on the project site and the locations are shown and labeled. (Check all of the following that apply)
 - The wells are not in use and have been properly abandoned.
 - The wells are not in use and will be properly abandoned.
 - The wells are in use and comply with 16 TAC §76.
 - There are no wells or test holes of any kind known to exist on the project site.
17. Geologic or manmade features which are on the site:
- All sensitive geologic or manmade features identified in the Geologic Assessment are shown and labeled.
 - No sensitive geologic or manmade features were identified in the Geologic Assessment.
 - Attachment G - Exception to the Geologic Assessment.** A request and justification for an exception to a portion of the Geologic Assessment is attached.

18. The drainage patterns and approximate slopes anticipated after major grading activities.
19. Areas of soil disturbance and areas which will not be disturbed.
20. Locations of major structural and nonstructural controls. These are the temporary best management practices.
21. Locations where soil stabilization practices are expected to occur.
22. Surface waters (including wetlands).
 N/A
23. Locations where stormwater discharges to surface water or sensitive features.
 There will be no discharges to surface water or sensitive features.
24. Legal boundaries of the site are shown.

UST System Profiles

25. **Attachment H - Profile Drawing(s).** A profile drawing(s) of the proposed UST system with all components shown and labeled is attached.

Best Management Practices

26. **Attachment I - Initial and Continuing Training.** A description of the initial and continuing training of on-site personnel for operation of release detection equipment is attached. The description should include how personnel will respond to warning and alarm conditions of the leak detection monitoring system.
27. **Attachment J - Release Detection Maintenance.** A description of the program and schedule for maintaining release detection and cathodic protection equipment is attached. Any such equipment should be operated and maintained in accordance with the manufacturer's specifications and instructions.

Administrative Information

28. A Water Pollution Abatement Plan (WPAP) is required for construction of any associated commercial, industrial or residential project located on the Recharge Zone.
 - The WPAP application for this project was approved by letter dated _____. A copy of the approval letter is attached at the end of this application.
 - The WPAP application for this project was submitted to the TCEQ on 4/24/2023, but has not been approved. Exception request as no new IC is proposed and development predates EAPP Rules
 - A WPAP application is required for an associated project, but it has not been submitted.
 - There will be no building or structure associated with this project. In the event a building or structure is needed in the future, the required WPAP will be submitted to the TCEQ.
 - The proposed UST is located on the **Transition Zone** and a WPAP is not required. Information requested in 30 TAC 213.5 subsection (b)(4)(B) and (C) and (5) is

provided with this application. (Forms TCEQ-0600 Permanent Stormwater Section and TCEQ-0602 Temporary Stormwater Section or Stormwater Pollution Prevention Plan/SW3P).

29. UST systems must be installed by a person possessing a valid certificate of registration in accordance with the requirements of 30 TAC Chapter 334 Subchapter I.
30. This facility is subject to and must meet the requirements of 30 TAC Chapter 334, including but not limited to the 30 day construction notification and reporting and cleanup of surface spills and overfills.
31. Upon completion of the tankhold excavation, a geologist must certify that the excavation was inspected for the presence of sensitive features. The certification must be submitted to the appropriate regional office. If sensitive features are found, then excavation near the feature may not proceed until the methods to protect the Edwards Aquifer are reviewed and approved by the executive director.
32. Submit one (1) original and one (1) copy of the application, plus additional copies as needed for each affected incorporated city, groundwater conservation district, and county in which the project will be located. The TCEQ will distribute the additional copies to these jurisdictions. The copies must be submitted to the appropriate regional office.
33. Any modification of this UST application will require TCEQ approval, prior to construction, and may require submission of a revised application, with appropriate fees.

ATTACHMENT A

Detailed Narrative of UST Facility

PROJECT DESCRIPTION

The subject site is located at 2509 S. Bell Blvd., Cedar Park, Williamson County, Texas. The site is located within the Edwards Aquifer Recharge Zone. The proposed commercial project is located at an existing gas station that was constructed before Edwards Aquifer rules were established. Per Tax Records, I.C. was constructed in 1971 and converted to fuel sales in 1993. The property has been surveyed and I.C. calculated per the related plan sheet (attached). The proposed construction entails tank replacement and new piping to the multiple product dispensers shown on the plan. Permanent Storm is not included in this plan due to the construction of the I.C. Pre-Dating the Rule for this project. As shown, the I.C. will not change as a result of the tank construction.

The areas surrounding the subject site supports mixed commercial and residential properties.

The proposed underground storage tank system will include a 20,000-gallon Modern Glasteel steel triple-wall tank containing gasoline and diesel (UL 58, UL 1746). The UST will be compartmentalized with the following storage capacity: 5,000-gallons gasoline, 5,000-gallons gasoline, and 10,000-gallons diesel. The corresponding underground storage tank sumps proposed are Bravo collar-mount tank sumps. Associated with this tank will be two (2) Gilbarco 700 S dispensers along with Dualoy 3000/LCX double-walled fiberglass piping.

The tank will be equipped with FE Petro submersible pumps (1.5 hp) for each compartment. Overfill prevention for each tank compartment will be provided by a valve assembly which will be installed in the tank below the vapor recovery fitting and will be set to shut off flow into the tank when the volume of liquid in the tank reaches no more than 95% of the tank capacity.

Product piping will be U.L. listed Dualoy 3000/LCX double wall fiberglass-reinforced plastic piping. Dualoy 3000/LCX pipe is UL 971 listed. Vent lines will be 2-inch diameter double-wall pipe. Under each dispenser, for each product grade, there will be a shear valve mounted to a rigid framework and installed at the dispenser island surface level to assure automatic shut-off of product flow during impact or fire emergencies. In addition, FLEX-ING flexible connectors will be installed at both ends of each product line in isolation sumps to connect to the dispenser unit and submersible pump.

Corrosion protection for the metallic components of the underground storage systems will be provided by electrical isolation. The submersible pump housings and pump-end flexible connectors will be installed within a Bravo Collar-Mount tank sump, which will provide isolation from the backfill material while also providing containment for any leaks from these components. The dispenser-end flexible connectors will be similarly isolated by enclosure within Bravo Economy B1000 Series under dispenser sumps.

The proposed tank and piping will be monitored for leaks by means of inventory control, tank monitor CSLD release detection software, sump and interstitial leak detection, and electronic line leak detection. The tank will be equipped with a liquid discrimination sensor which will be installed adjacent to the submersible pumps in the sumps and in all dispenser sumps. The tank will also be equipped with an electronic automatic tank gauging inventory probe for inventory of the product volume in the tank.

The controller will be equipped with Continuous Statistical Leak Detection to meet TCEQ release detection requirements. Each product piping line will be equipped with mechanical line leak detection. The probes and sensors from the tank will be connected to a Veeder-Root 450 TLS programmable control unit to be located in the store building. The tank interstitial is monitored with a Veeder Root interstitial sensor which will set off an alarm if liquid enters the tank interstitial. This central monitoring unit is designed to provide visual and audible alarms when hydrocarbon liquids or water is detected.

ATTACHMENT B

Manufacturer Information for Tanks

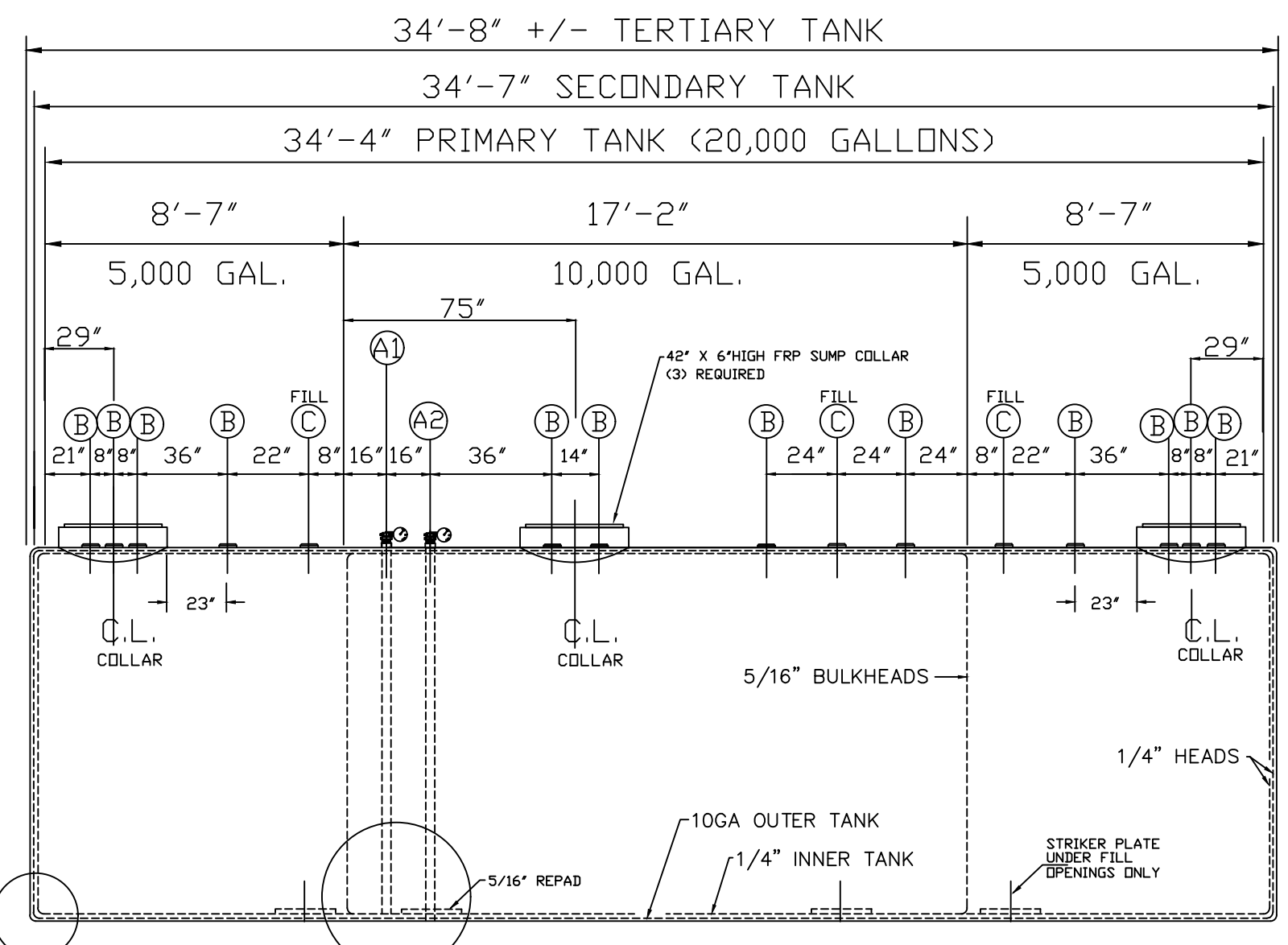
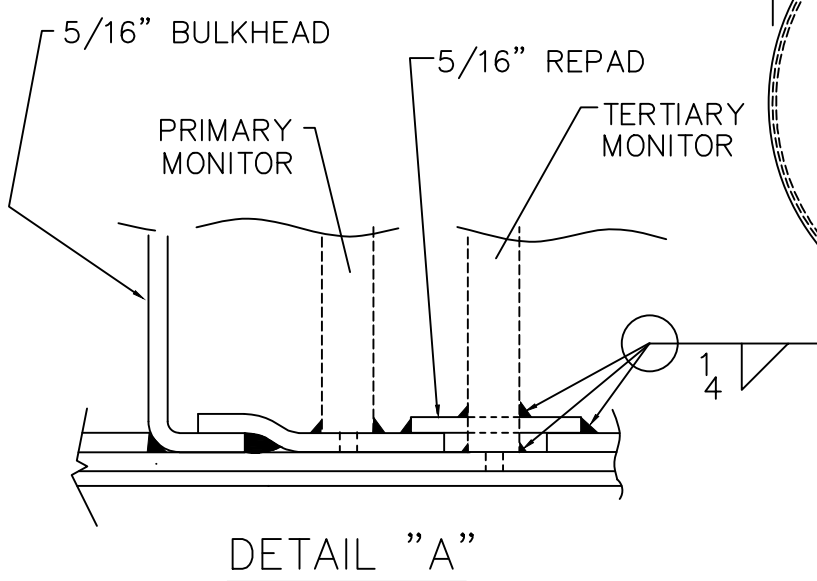
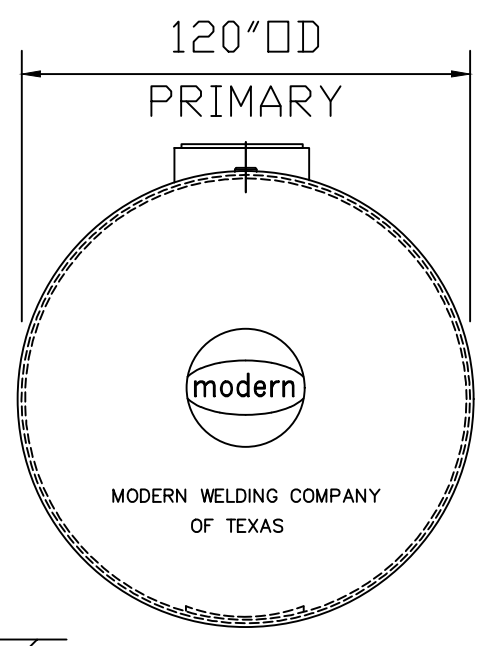
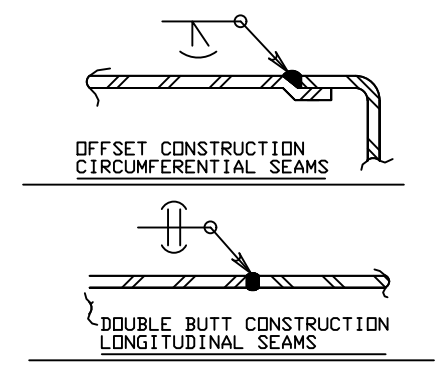
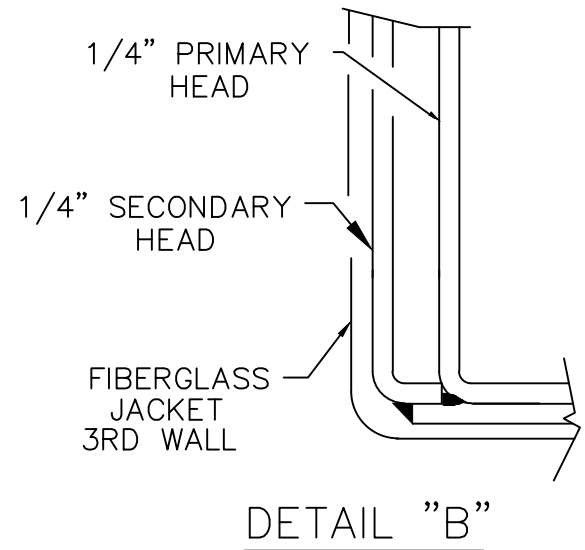

CONSTRUCTED PER UL-58 / UL 1746 PART III
 WILL BEAR THE UL 1746 PART III LABEL
 APROX. WEIGHT: 27,000#
PRI. & SEC. TANK ARE MADE OF CARBON STEEL MATERIAL PER UL-58
 EXT. COATING: 100 MILS. MIN. FRP
 TANK SHALL MEET THE REQUIRMENTS OF NFPA 30 & 31.
 TANK SHALL MEET THE REQUIRMENTS OF UFC.
 TANK SHALL MEET THE REQUIREMENTS OF SCAQMD METHANDL COMPATIBILITY RULE 1170.
 TANK SHALL HAVE 30 YEAR LIMITED WARRANTY.

THIS TANK ARRIVES AT THE JOBSITE UNDER VACUUM AND DOES NOT REQUIRE FURTHER INTEGRITY TESTS. IF JOBSITE AIR PRESSURE TEST REQUIRED, THE PRIMARY TANK MAY BE PRESSURIZED UP TO 5 P. S. I. THE SECONDARY AND THIRD TANK MAY BE TESTED BY VACUUM ONLY. THE OUTER TANK RECEIVES A 35,000 VOLTS. HOLIDAY TEST AT THE FACTORY.

3" CPLG. W/3"x2" NYLON BUSHING

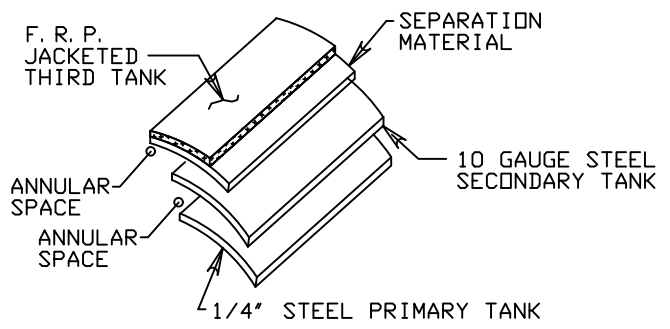

INTERIOR: CLEAN OF DEBRIS, UNPAINTE
 EXTERIOR: F. R. P.

CONSTRUCTION DETAILS

MARK	REQ'D	SIZE	TYPE	RATING	REMARKS
C	3	5"	FNPT		FILL w/5x4 BUSHINGS & striker plt.
B	12	5"	FNPT		w/ 5X4 BUSHINGS
A2	1	3"	FNPT		Tertiary Monitor w/3x2 bush
A1	1	3"	FNPT		PRIMARY Monitor w/3x2 bush

SCHEDULE OF OPENINGS

NOTE: OPENINGS 'B' & 'C' ARE TO HAVE 5"x4" NYLON BUSHINGS.

SHIPPING INFORMATION	
COMPANY NAME	-
SHIPPING ADDRESS	2509 SOUTH BELL CEDAR PARK, TX

NO. REQD.: ONE (1)		ITEM NO.:	
MODERN WELDING OF HOUSTON, INC.			
TEXAS FUEL SOLUTIONS 20,000 GALLON GLASTEEL TRIPLE WALL UST SPLIT 5/10/5			
DWN. BY	KK	DATE	3-13-23
CHK. BY		JOB NO.	31401-1
APR. BY		P.O. NO.	EDGAR
		SCALE:	NONE
		DWG. NO.	
		SHT. NO.	1 OF 1

GLASTEELTM

DOUBLE WALL TANKS

Please note, this cut sheet is for a DW Glasteel tank. Modern Welding does not have a cut sheet for a TW Glasteel tank. The proposed tank will have a primary and secondary steel tank with a tertiary fiberglass tank.

GLASTEELTM

SINGLE WALL TANKS

Underground Storage Containment!

NOTES: Although this is a double wall tank, please note that the tank for this site will have an additional steel tank inserted within the double wall Glasteel tank making it tertiary containment.



MODERN WELDING
Co., Inc.

GLASTEEL^{T.M.} SINGLE WALL

The Ultimate Barrier Against The Elements!

GLASTEEL! It begins with a tank made of high-grade, all-welded steel which, in itself, can handle gasoline, jet fuel, diesel fuel, ethanol, neat methanol, M-85 and E-58.

The Glasteel process completely clads the original steel tank in a corrosive resistant armor. There is no need for soil resistivity testing, or expensive cathodic protection systems, because even highly corrosive soil will not affect the Glasteel tank. Striker plates on the bottom of the tank are directly beneath all openings. This allows any opening to be used for any purpose.

Your Glasteel tank, when completed, will be delivered to you on time. Regional delivery could also save on freight charges.

Glasteel tanks are installation friendly and carry a limited warranty. Tanks comply to the Steel Tank Institute's ACT-100 specifications.

For over six decades, Modern Welding has been an industry leader in fabricated steel storage tanks. Today with eight tank subsidiaries across the country, we can provide you with fast, efficient service no matter where you are located.

From 550 to 50,000 gallons, tanks may be purchased with compartment bulkheads for multiple fuel storage. Tanks come in single wall and double wall steel constructions with and without containment sumps. Call the nearest Modern subsidiary for competitive pricing and regional service. Visit our website at: www.modweldco.com.

- NO MONITORING REQUIRED
- AVAILABLE IN SINGLE OR DOUBLE WALL
- MAINTENANCE FREE

Ethanol Fuels

The Steel Tank Institute has researched compatibility issues concerning the storage of ethanol based fuels. Shop fabricated "Steel" underground and aboveground storage tanks, when used for the storage of ethanol based fuels, has exhibited no long term detrimental structural or permeation issues. As with all fuels, STI recommends that tank owners implement a maintenance program for all tanks and associated equipment, including monitoring and removing water that may accumulate within the tank system.



Steel Tank

UL-1746 "LISTED" Coating
Corrosion-Resistant Barrier

NOTES: Although this is a double wall tank, please note that the tank for this site will have an additional steel tank inserted within the double wall Glasteel tank making it tertiary containment.

GLASTEEL^{T.M.} DOUBLE WALL

Secondary Containment at its BEST

Double your feeling of security with a Glasteel Double Wall Tank. We know that protecting the environment is, and will continue to be, one of the hottest topics our industry faces during the coming decades. That's why Modern Welding's GLASTEEL DOUBLE WALL is the very finest secondary containment tank available in the market today.

GLASTEEL tanks are built to EPA requirements, Underwriters Laboratories' standards 58 & 1746 and the Steel Tank Institute's ACT-100 specifications. Tanks may be purchased with openings located along the top centerline of tank, or fittings may be grouped for containment within sump collar assemblies . . . choose the configuration right for your installation.

Compatibility

GLASTEEL DOUBLE WALL primary UL steel tank is available with internal linings for the broadest compatibility available with all fuels, including gasoline, jet fuel, diesel fuel, ethanol, neat methanol, M-85, and E-85.

Superior Performance; Easy Installation

- Cathodic protection, dielectric isolation not required.
- GLASTEEL DOUBLE WALL tanks come with Modern Welding's limited warranty.
- Simple installation procedures; special backfill not required to maintain structural integrity.

Ethanol Fuels

The Steel Tank Institute has researched compatibility issues concerning the storage of ethanol based fuels. Shop fabricated "Steel" underground and aboveground storage tanks, when used for the storage of ethanol based fuels, has exhibited no long term detrimental structural or permeation issues. As with all fuels, STI recommends that tank owners implement a maintenance program for all tanks and associated equipment, including monitoring and removing water that may accumulate within the tank system.



MODERN WELDING
Co., INC.

Modern Welding... Quality and Leadership.

Phone: (270) 685-4400 • Fax: (270) 684-6972

1 800 922 1932



MODERN WELDING CO., INC.

Corporate Offices

2880 New Hartford Road • Owensboro, KY 42303
Phone: 270-685-4400 • Fax: 270-684-6972
www.modweldco.com • E-mail: modern@modweldco.com

1 800 922 1932

Manufacturing Subsidiaries

Modern Welding Co. of Owensboro, Inc.

1450 E. Parrish Ave.
Owensboro, Kentucky 42303
Phone: 270-683-5323
Fax: 270-684-5245
modern1@modweldco.com

Modern Welding Co. of Ohio, Inc.

One Modern Way
Newark, Ohio 43055
Phone: 740-344-9425
Fax: 740-344-6018
modern5@modweldco.com

Modern Welding Co. of Florida, Inc.

1801 Atlanta Ave.
Orlando, Florida 32806
Phone: 407-843-1270
Fax: 407-423-8187

modern6@modweldco.com

Modern Welding Co. of Texas, Inc.

2 Locations
715 Sakowitz St.
Houston, Texas 77020
Phone: 713-675-4211
Fax: 713-673-4062
modern7@modweldco.com

200 N. Main St.
Rhome, Texas 76078
Phone: 817-636-2215
Fax: 817-636-2680
modern15@modweldco.com

Modern Welding Co. of Iowa, Inc.

2818 Mt. Pleasant Rd.
Burlington, Iowa 52601
Phone: 319-754-6577
Fax: 319-754-8428

modern8@modweldco.com

Modern Welding Co. of California, Inc.

4141 N. Brawley Ave.
Fresno, California 93722
Phone: 559-275-9353
Fax: 559-275-4381
modern10@modweldco.com

Modern Welding Co. of Georgia, Inc.

300 Prep Phillips Dr.
Augusta, Georgia 30901
Phone: 706-722-3411
Fax: 706-724-8133
modern14@modweldco.com



ATTACHMENT D

Manufacturer Information for Piping

Dualoy® 3000/LCX Product Data

Applications

Rigid fiberglass coaxial fuel handling systems requiring Underwriters Laboratories Listing for integral primary and containment piping conveying the following fuels:

- Motor Vehicle (MV)
- Aviation and Marine A&M)
- High Blend (HB)
- Bio-Diesel
- Concentrated (CT)
- Diesel Exhaust Fluid

Description

Dualoy 3000/LCX rigid fiberglass coaxial piping is a cost-effective solution for contained piping systems. LCX is used for product delivery lines in underground fuel handling systems to convey fuel from the tank to the dispensers. Dualoy 3000/LCX pipe is UL Listed for use with motor vehicle (MV), high blend (HB), concentrated (CT) and aviation and marine (A&M) fuels. Based on currently known tests, NOV Fiber Glass Systems found this product to be suitable for conveying all blends of biodiesel and ethanol type fuels and the conveyance of DEF.

The LCX pipe is manufactured as an integral unit. The primary is made of chemically inert, non-permeable, fiberglass reinforced epoxy resin which is inherently resistant to deterioration due to water and microbial attack. This layer is covered with a porous layer to provide the small volume interstitial space, which facilitates rapid leak detection. Then, the containment layer, comprised of the same material as the primary, is wound over the primary and porous layers.

The containment system is installed with custom designed clamshell containment fittings. Both the primary and containment systems are bonded for long-term, reliable performance.

- Dualoy 3000/LCX containment fittings are typically bolted in place while the adhesive cures.
- Dualoy 3000/LCX reduces installation and inspection time dramatically, retaining system integrity.
- Dualoy 3000/LCX double wall design significantly improves impact resistance over single wall pipe.
- Dualoy 3000/LCX systems provide true double wall design which permits rapid communication through the interstice.

Listings and Approvals

The rigid fiberglass piping used in Dualoy 3000/LCX is Listed in the United States with Underwriters Laboratories for nonmetallic underground piping for MV, HB, CT and A&M fuels under File No. MH9162. Dualoy 3000/LCX pipe and fittings are also Listed with Underwriters Laboratories of Canada for Petroleum Products and Oxygenated Fuels (File CMH715). Underwriters Laboratories has also approved Dualoy 3000/L and Dualoy 3000/LCX for use with MTBE fluids.

Performance

Primary operating pressures to 200 psig (13.8 bar)

Continuous operating temperature to 150°F (66°C)

Containment system pressures to 50 psig (3.45 bar)

Individual system components may not have the same ratings as the pipe. Refer to the detailed product information for the specific components to determine the pressure rating for the system as a whole.

Composition

Primary pipe: Filament-wound fiberglass reinforced epoxy pipe with integral epoxy liner. When classified in accordance with ASTM D2310 and ASTM D2996, the pipe meets the following cell limits: RTRP 11CF1-5420.

Pipe containment: Filament-wound fiberglass reinforced epoxy pipe.

Interstitial space: Dry, graded glass beads secured in place with adhesive backed tape.

Fittings: Compression molded or filament-wound fiberglass reinforced epoxy primary fittings. Containment fittings are molded.

Adhesive: PSX™ •20 or PSX™ •34 ambient-cure, two-part epoxy for all services (including alcohols and MTBE).

Joining System Primary:

Bell and spigot taper/taper adhesive-bonded joint

Containment:

Adhesive-bonded clamshell fittings. Parts are compression molded for exact fit and match. Material is identical to primary fittings and is UL Listed for all services, including use in MTBE fluids.

Pipe Lengths

Standard 20 ft. (6.1 m) random lengths 17 to 21 ft. (5.2 to 6.4 m) and 30 ft. (9.1 m) random lengths 27 to 32 ft. (8.2 to 9.7 m)

Other lengths up to 42 ft. (12.8 m) available upon request.

Fittings

Primary	Adapters: bell x NPT male ⁽¹⁾ Adapters: bell x NPT female ⁽²⁾ Adapters: spigot x NPT female ⁽²⁾ Adapters: spigot x NPT male ⁽²⁾ 45° elbows ⁽¹⁾ 90° elbows ⁽¹⁾ End caps ⁽¹⁾ Flange rings ⁽¹⁾	Flange stub ends ⁽¹⁾ Isolation bushings ⁽¹⁾ Nipples ⁽²⁾ Reducer bushings ⁽¹⁾ Repair couplings ⁽¹⁾ Sleeve couplings ⁽²⁾ Tees ⁽¹⁾ Dispenser pan penetration fittings ⁽¹⁾
Containment	45° elbows ⁽¹⁾ 90° elbows ⁽¹⁾ Termination sleeves ^{(1), (3)}	Couplings ⁽¹⁾ Tees ⁽¹⁾

⁽¹⁾ Molded fitting

⁽²⁾ Filament-wound fitting

⁽³⁾ 2" (50 mm) available with or without test valve. 3" and 4" (80 and 100 mm) available only with test valve

Typical Pipe Dimensions and Weights

Pipe Size		Primary Pipe ID		Primary Pipe OD ⁽¹⁾		Primary Wall Thickness		Containment OD		Capacity		Weight	
in	mm	in	mm	in	mm	in	mm	in	mm	gal/ft	l/m	lb/ft	kg/m
2	50	2.21	56	2.37	60	0.080	2.03	2.59	66	0.20	0.76	0.90	1.34
3	80	3.32	84	3.50	89	0.085	2.16	3.70	94	0.45	1.70	1.30	1.93
4	100	4.33	110	4.50	114	0.087	2.21	4.70	119	0.77	2.92	1.74	2.59

⁽¹⁾ Typical outside diameters of 2"-4" (50 -100 mm) pipe are within API, ASTM and ANSI fiberglass and steel pipe dimensions.

Typical Primary Pipe Performance

Pipe Size		Pressure Rating ⁽¹⁾		Ultimate Internal Pressure ⁽¹⁾		Ultimate Collapse Pressure ⁽²⁾	
in	mm	psig	MPa	psig	MPa	psig	MPa
2	50	200	2.07	1500	10.3	153	1.05
3	80	200	1.38	1000	6.9	90	0.62
4	100	175	1.21	750	5.2	39	0.27

⁽¹⁾ At 80°F (27°C)

⁽²⁾ At 80°F (27°C) For continuous service do not exceed 75% of these values.

Fittings Pressure Performance

Pipe Size		Primary All Fittings		Containment Clamshell Fittings	
in	mm	psig	MPa	psig	kPa
2	50	200	1.38	50 ⁽¹⁾	345
3	80	125	0.86	50 ⁽¹⁾	345
4	100	100	0.69	20	138

⁽¹⁾ With reinforcing rings

For dimensions of primary fittings, consult Dualoy 3000/L Fittings Dimensions document. Pressure ratings of fittings without UL Listing are available on request.

Dualoy 3000/LCX piping systems are designed to function at temperatures ranging from -40 to 150°F (-40 to 66°C) at service pressures between -1 and 13.8 bar. Dualoy 3000/LCX pipe conforms to ASTM D2310, D2517 and D2996.

Typical Physical Properties of Primary Pipe			
Pipe Property	Units	Value	ASTM
Thermal conductivity	Btu-in/(h•ft ² •°F)	1.7	C177
	W/m•°C	7.6	
Linear thermal expansion	10 ⁻⁶ in/in/°F	8.5	D696
	10 ⁻⁶ cm/cm/°C	15.3	
Friction factor	Hazen-Williams	150.0	—
Absolute roughness	10 ⁻⁶ ft	15.0	—
	10 ⁻⁶ m	4.6	
Specific gravity	—	1.81	D792
Barcol Hardness	Impressor 934-1	65.0	D2583

Typical Mechanical Properties of Primary Pipe			
Pipe Property ⁽¹⁾	Units	Value ⁽¹⁾	ASTM
Tensile strength Longitudinal	10 ³ psi MPa	35.0	D2105
		241.0	
Circumferential	10 ³ psi MPa	70.0	D1599
		483.0	
Tensile modulus Longitudinal	10 ⁶ psi GPa	2.5	D2105
		17.2	
Circumferential	10 ⁶ psi GPa	3.8	FGSTM
		26.2	
Compressive strength Longitudinal	10 ³ psi MPa	24.5	FGSTM
		168.9	
Compressive modulus Longitudinal	10 ⁶ psi GPa	2.6	FGSTM
		17.8	
Cyclic	10 ³ psi MPa	8.0	D2992(A)
		55.0	
Poisson's Ratio ⁽²⁾	—	0.16	FGSTM
		0.17	FGSTM

⁽¹⁾ Based on structural wall thickness.

⁽²⁾ The first subscript denotes the direction of applied stress and the second that of measured contraction
 x denotes longitudinal direction.
 y denotes circumferential direction.

Bending Radius						
Pipe Size		Minimum Bending Radius ⁽¹⁾		Maximum Deflection per 20 ft Joint	Minimum Length Required for 10° Change	
in	mm	ft	m	deg	ft	m
2	50	75	23	15	13	4
3	80	100	38	9	22	7
4	100	150	46	7.5	27	8

⁽¹⁾ At rated pressure. Sharper bends may create excessive stress concentrations. Do not bend pipe until adhesive has cured.

National Oilwell Varco has produced this brochure for general information only, and it is not intended for design purposes. Although every effort has been made to maintain the accuracy and reliability of its contents, National Oilwell Varco in no way assumes responsibility for liability for any loss, damage or injury resulting from the use of information and data herein nor is any warranty expressed or implied. Always cross-reference the bulletin date with the most current version listed at the web site noted in this literature.

North America

17115 San Pedro Ave. Suite 200
San Antonio, Texas 78232 USA
Phone: 210 477 7500

South America

Avenida Fernando Simoes
Recife, Brazil 51020-390
Phone: 55 31 3501 0023

Europe

P.O. Box 6, 4190 CA
Geldermalsen, The Netherlands
Phone: 31 345 587 587

Asia Pacific

No. 7A, Tuas Avenue 3
Jurong, Singapore 639407
Phone: 65 6861 6118

Middle East

P.O. Box 17324
Dubai, UAE
Phone: 971 4881 3566

ATTACHMENT G

Exception to the Geologic Assessment

Geologic Assessment

REGULATED ENTITY NAME: Super 365

TYPE OF PROJECT: WPAP AST SCS UST

LOCATION OF PROJECT: Recharge Zone Transition Zone Contributing Zone
within the
Transition Zone

Ranger Environmental Services, Inc. (Ranger) field personnel attempted to perform the required Geologic Assessment at the aforementioned facility located at 2509 S. Bell Blvd., Cedar Park, Williamson County, Texas on March 20, 2023. During the site visit, it was observed that the site has been previously developed and appeared to operate as a retail fueling facility and convenience store. The site was noted to be less than 0.5 acres in size and is mostly impervious cover. It appears that the site pre-dated the Edwards rule at the time of original development.

Therefore, based on the site currently being developed with mostly impervious cover and the fact that the native soils are not exposed, it is requested that an exception to the Geologic Assessment requirement be granted.

To the best of my knowledge, the responses to this form accurately reflect all information requested concerning the proposed regulated activities and methods to protect the Edwards Aquifer. My signature certifies that I am qualified as a geologist as defined by 30 TAC Chapter 213.

Chad M. Copeland, PG, PWS

512/335-1785
Telephone

512/335-0527
Fax

03/20/2023
Date



Signature of Geoscientist

Representing: Ranger Environmental Services, LLC
(Name of Company)

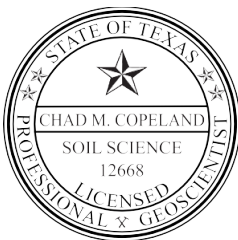



03/20/2023

ATTACHMENT H

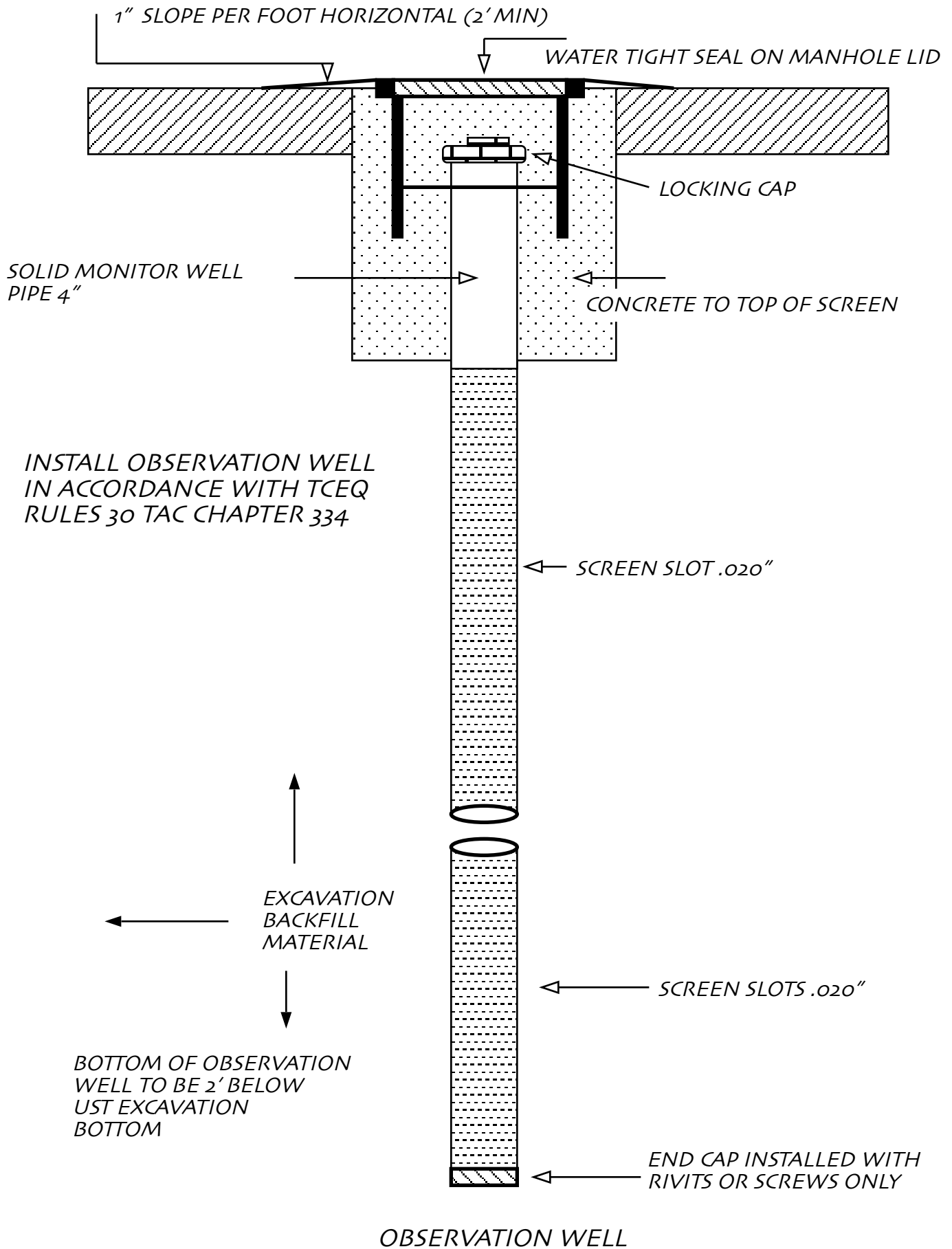
Profile Drawings

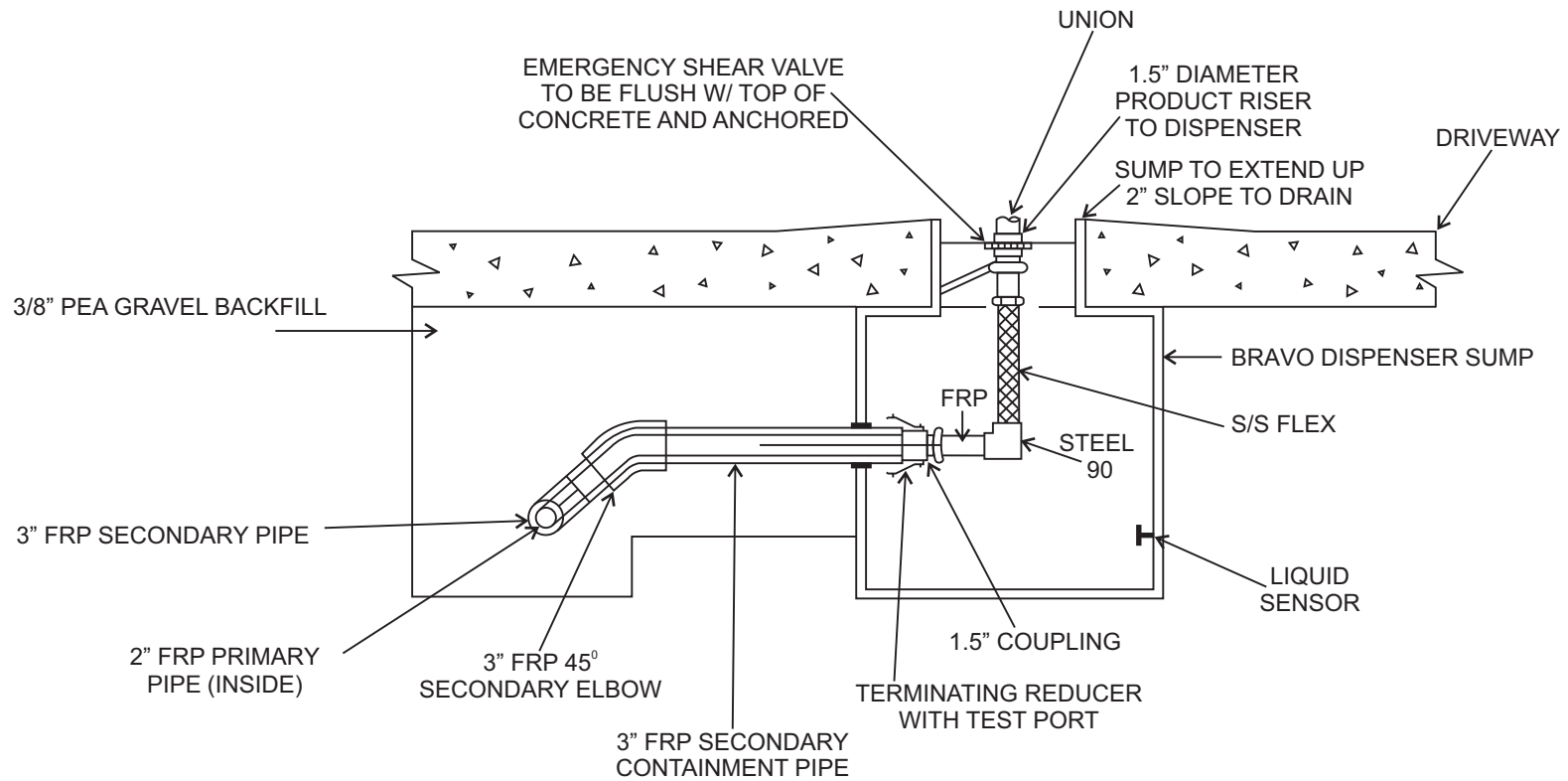



DISPENSER PIPING
NOT TO SCALE

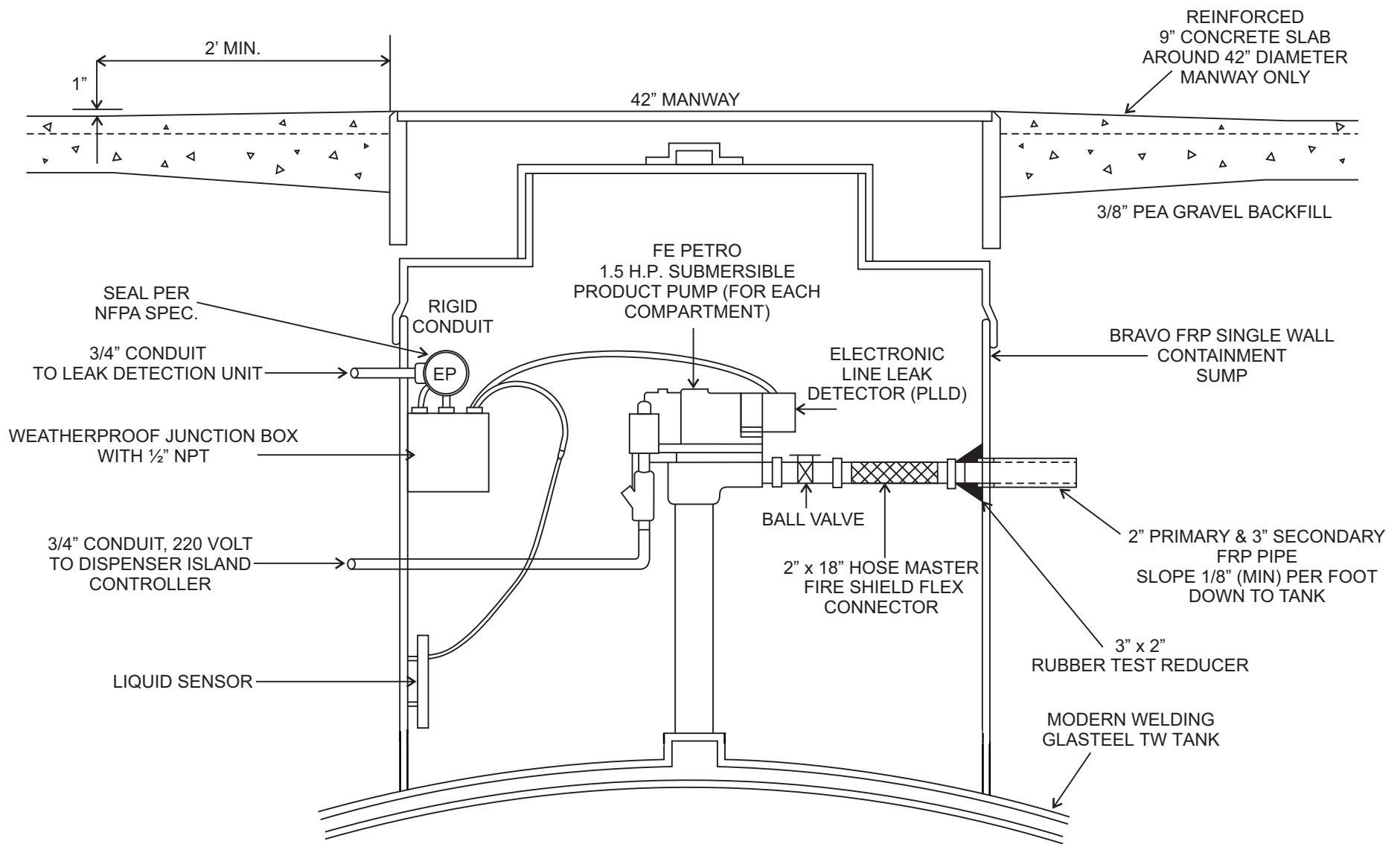

TYPICAL SUBMERSIBLE PUMP ASSEMBLY
NOT TO SCALE

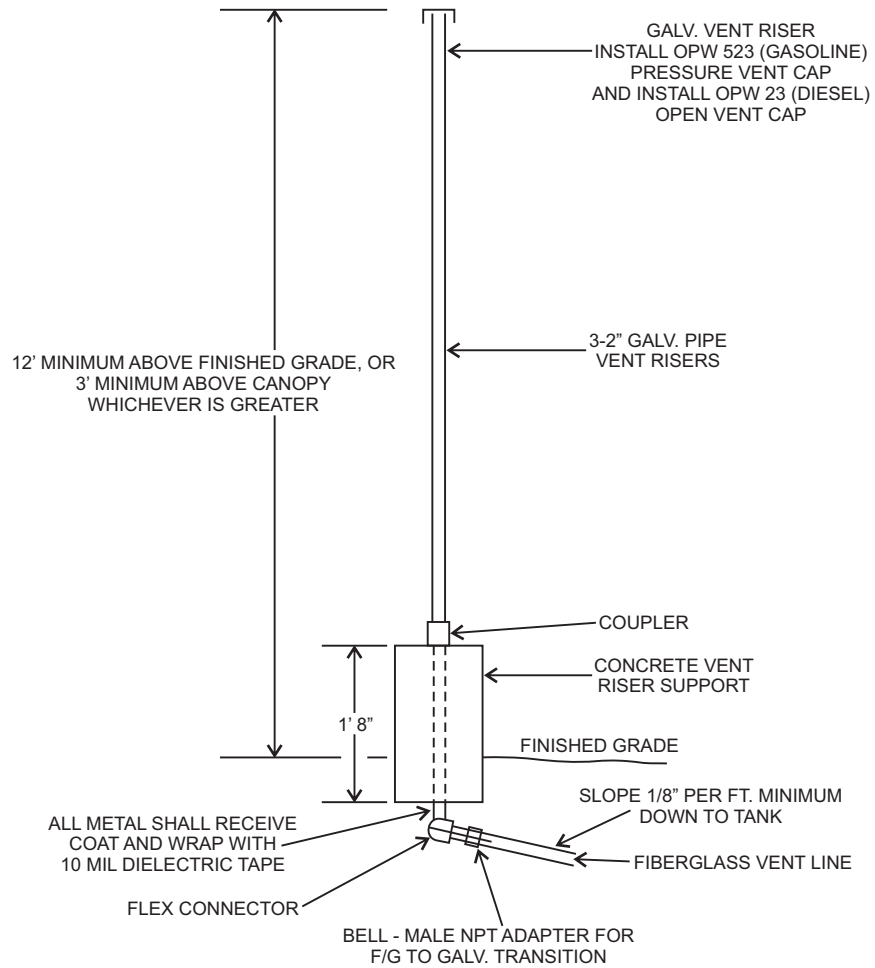

TANK VENT RISER
NOT TO SCALE

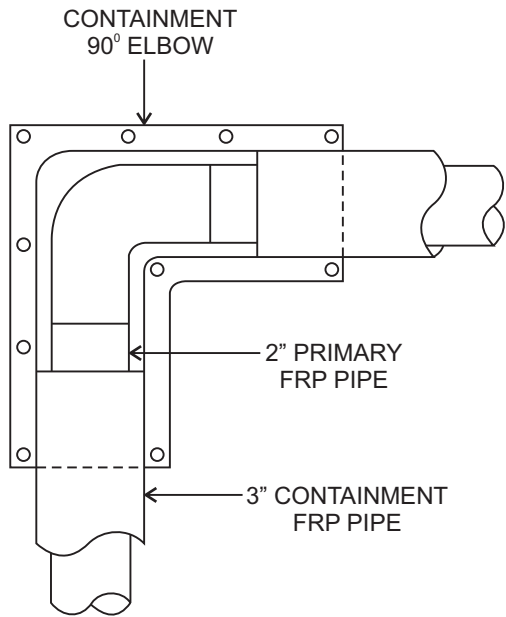

TYPICAL 90° ELBOW

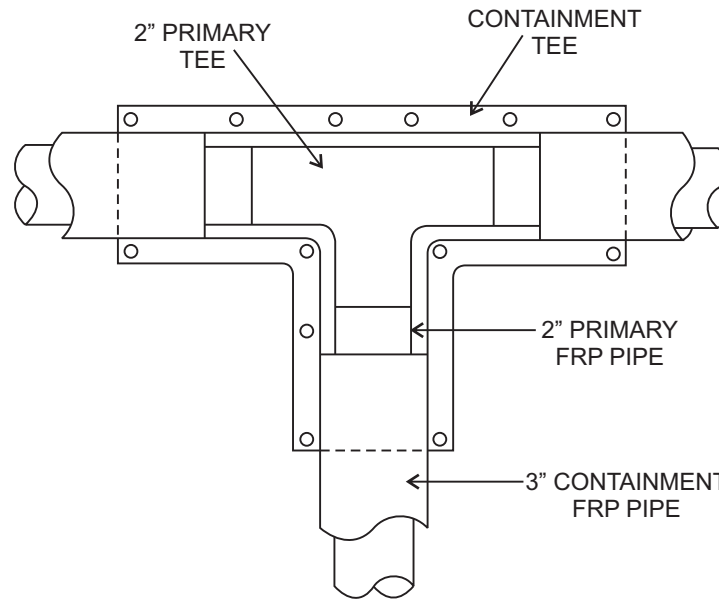

TYPICAL THREE WAY TEE

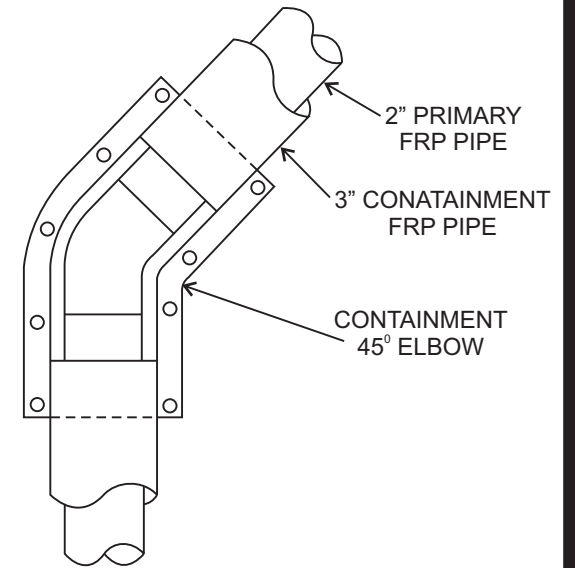

TYPICAL 45° ELBOW

DOUALY 3000/LCX DOUBLE WALL FIBERGLASS PIPING

PIPING PLAN NOT TO SCALE

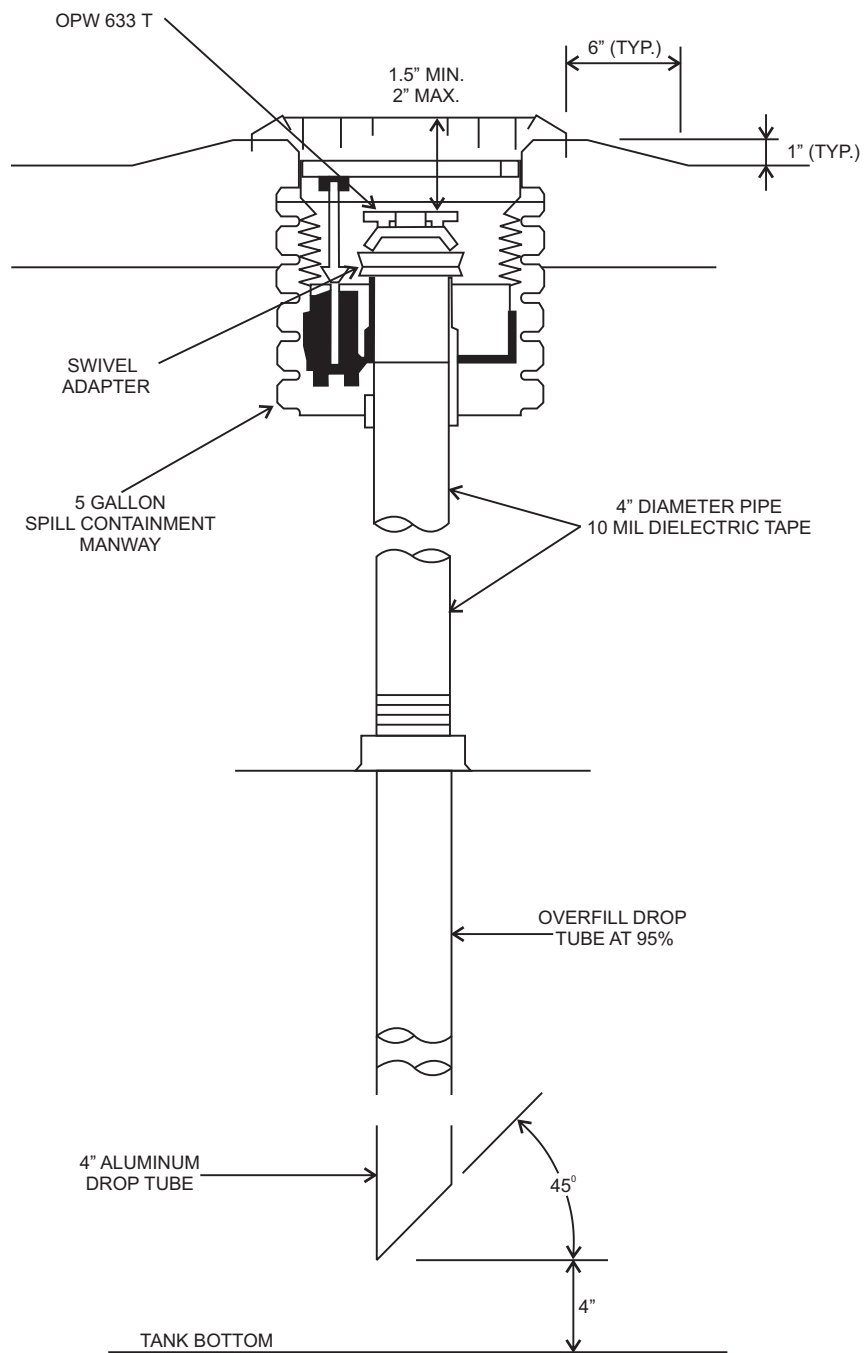

FILL RISER DETAIL
NOT TO SCALE

Console Description

The TLS-450PLUS Automatic Tank Gauge (ATG) is a powerful tool that allows fueling operations to run at peak efficiency, with an easy to understand navigation, streamlined inventory and compliance reporting, and powerful business analytics. It can monitor up to 64 tanks, or 32 tanks with BIR. Frequent releases of operating software for the TLS-450PLUS tank gauge assures that data is secure and software features are routinely updated and enhanced.

TLS-450PLUS Consoles, Standard Hardware & Software
Part # & Description

- 860091-301 TLS-450PLUS Console with 8" WVGA Color Touch Screen Display, Printer, 3 Ethernet and Dual USB/Expansion, Dual RS-232, UL/cUL
- 860091-302 TLS-450PLUS Console with 8" WVGA Color Touch Screen Display, Printer, 3 Ethernet and Dual USB/Expansion, Dual RS-232/RS-485, UL/cUL
- 860091-401 TLS-450PLUS Console with 8" WVGA Color Touch Screen Display, No Printer, 3 Ethernet and Dual USB/Expansion, Dual RS-232, UL/cUL
- 860091-402 TLS-450PLUS Console with 8" WVGA Color Touch Screen Display, No Printer, 3 Ethernet and Dual USB/Expansion, Dual RS-232/RS-485, UL/cUL
- 860091-001 TLS-450PLUS Console, No Display, No Printer, 3 Ethernet and Dual USB/Expansion, Dual RS-232, UL/cUL
- 860091-002 TLS-450PLUS Console, No Display, No Printer, 3 Ethernet and Dual USB/Expansion, Dual RS-232/RS-485, UL/cUL

Standard Hardware & Application Software

Software – 333545-001 Application Software (must be ordered with Console) includes Web-enabled, Custom Alarm, On-Console Help, Extended Storage, TLS-Expansion, Static Leak Detection, 3GPH DPLLD

Hardware – 3 Port Ethernet Module (Comm Slot 4), 2-Port USB Module (Comm Slot 5), 3 module compartments

Devices

Module Compatibility	Inputs per Module	iButton Req'd?	Console Slots				TLS-XB 1 Slots				TLS-XB 2 Slots				TLS-XB 3 Slots				Modules per System
			1	2	3	4	1	2	3	4	1	2	3	4	1	2	3	4	
TLS-450PLUS System																			
USM	16	POWER MODULES	●	●	●	●	●	●	●	●	●	●	●	●	●	●	●	●	16
UIOM	14 ¹		●	●	●	●	●	●	●	●	●	●	●	●	●	●	●	●	16
10-Amp Relay	6					●				●				●				●	4
MDIM	12		●	●	●	●	●												5
LVDIM	12		●	●	●	●	●												5

¹=(14) total inputs include (5) AC Inputs, (5) Relay Contacts, (4) 12VDC Inputs

Communications
TLS-450PLUS Device & Communications Module Compatibility

Module	COMMUNICATION MODULES	Console					Modules per System	Type			
		1 ⁴	2	3	4	5					
		P1	P2	P1	P2	P1	P2	P1	P2		
TLS-450PLUS											
RS-232	COMMUNICATION MODULES	●		●		●				3	Hardware
Dual RS-232		●	●	●	●					3	Hardware
RS-485		●		●		●				3	Hardware
Dual RS-485 ¹		●	●	●	●					3	Hardware
RS-232/RS-485 ¹		●	●	●	●					3	Hardware
Internal Modem		●	●	●	●	●				3	Hardware
CDIM		●	●	●	●	●				2	Hardware
EDIM ²		●	●	●	●	●				3	Software
IFSF LON ³	●	●	●	●	●				1	Hardware	

¹=When placed in Slot 3, only Position 2 will be functional

²=EDIM can be programmed in any position with an RS-232 port - up to 3 per system

³=Can be combined with EDIM

⁴=Console ships standard with dual RS-232 or dual RS-232/RS-485 card in Slot 1

TLS-450PLUS Device Modules	Part # & Description		Maximum # of Modules per Console	# of Inputs per Module	Availability
	Universal Sensor Module (USM) Interface for all Probes, Sensors, and DPLLD	332812-001 – Factory Installed Module 330020-619 – Spare Part Module	Up to 4 for each TLS-450PLUS and/or TLS-XB or a maximum of 16 modules per system	16	Sold Separately (either Factory Installed or as a Spare Part Module)
	Universal Input/Output Interface Module (UIOM) for Relay Control and Input Signal Monitoring	332813-001 – Factory Installed Module 330020-620 – Spare Part Module	Up to 4 for each TLS-450PLUS and/or TLS-XB or a maximum of 16 modules per system	5 dry contact output relays / 4 low voltage dry contact inputs / 5 high voltage inputs (<=240 VAC)	
	10-Amp Relay Module has 6 high power outputs / 6 low voltage inputs / must be installed in slot 4 of TLS-450 PLUS and TLS-XB	333564-001 – Factory Installed Module 330020-814 – Spare Part Module	Up to 1 for each TLS-450PLUS and/or TLS-XB or a maximum of 4 modules per system – <i>*Only installed in slot 4</i>	4	
	BIR/AccuChart LVDIM for TLS-450PLUS, 12 Inputs	333581-001 – Factory Installed Module 330020-800 – Spare Part Module			
	BIR/AccuChart MDIM for TLS-450PLUS, 12 Inputs	333582-001 – Factory Installed Module 330020-799 – Spare Part Module			
TLS-450PLUS Communications Modules	Part # & Description		Maximum # of Modules per System	Availability	
	SiteFax™ Interface Module (Comm. Slots 1,2,3), for TLS-450PLUS	332818-001 – Factory Installed Module 330020-612 – Spare Part Module	Up to 3 per System	Sold Separately (either Factory Installed or as a Spare Part Module) For Spare Part “upgrade” kits, the BIR/AccuChart Feature Enhancement will be shipped on a Veeder-Root iButton adapter – P/N 330020-659	
	Single RS-232 Interface Module (Comm. Slots 1,2,3), for TLS-450PLUS	332866-001 – Factory Installed Module 330020-613 – Spare Part Module			
	RS-232 Dual Interface Module (Comm. Slots 1,2,3), for TLS-450PLUS	332868-001 – Factory Installed Module 330020-617 – Spare Part Module			
	Single RS-232/RS-485 Dual Interface Module (Comm. Slots 1,2,3), for TLS-450PLUS	332870-001 – Factory Installed Module 330020-618 – Spare Part Module			
	BIR/AccuChart EDIM for TLS-450PLUS	333149-001 – Factory Installed Module 330020-801 – Spare Part Module	1 per System		
	BIR/AccuChart CDIM for TLS-450PLUS, 3 Inputs	333580-001 – Factory Installed Module 330020-802 – Spare Part Module			
	IFSF LON Interface Module (Comm. Slots 1,2,3), for TLS-450PLUS	333659-001 – Factory Installed Module 330020-828 – Spare Part Module			
TLS-450PLUS Optional Software	Part # & Description				
	Continuous Statistical Leak Detection (CSLD) for TLS-450PLUS		332972-006		
	Ultimate Testing: Digital Line Leak Detection for TLS-450PLUS		332972-007		
	Risk Management: Digital Line Leak Detection for TLS-450PLUS		332972-008		
	Base Compliance: Digital Line Leak Detection for TLS-450PLUS		332972-009		
	Timed Sudden Loss Detection for TLS-450PLUS		332972-018		
	Vapor Collection Monitor for TLS-450PLUS		332972-021		
	DEF Recirculation Software Feature for TLS-450PLUS & DEF Temperature Sensor Installation Kit		332972-026 – Software 794380-210 – Install Kit		

Specifications	
Operating Temperature	+32 to +104°F (0 to +40°C)
Storage Temperature	-40 to +158°F (-40 to +70°C)
Installation Location	NEMA 4 or indoors
Relative Humidity	0-90% (non-condensing)
External Dimensions	18.4" x 11" x 8.8" (46.74cm x 27.94cm x 22.35cm)
Construction	16GA (0.060 in/0.1524 cm) powder coated steel
Console Power Wiring Requirements	AC Power Wiring – Wires carrying 120 or 240 VAC from power panel to the console should be #14 AWG (or larger) wire for line, neutral & chassis ground (3) ; and 4 sq. mm, rated for at least 90C for barrier ground.
Probe & Sensor to Console Wiring Requirements	<ol style="list-style-type: none"> 1. Wire Type – Shielded cable required regardless of conduit material or application. It must be rated less than 100 picofarad per ft manufactured with a suitable material such as Carol C2534 or Belden 88760, 8760, or 8770. 2. Wire Length – Maximum 1,000ft (304.8m) to meet intrinsic safety requirements. Improper system operation could result for runs over 1,000ft (304.8m). 3. Wire Gauges – Color coded – shielded cable used in all installations. Wires should be #14 - #18 AWG stranded copper wire and installed as Class 2 circuits. As an alternate method when approved by the local authority having jurisdiction, #22 AWG wire such as 88761 may be suitable with the following requirements: Wire run is less than 750ft (228.6m), Capacitance does not exceed 100 pF/ft; Inductance does not exceed 0.2 uH/ft.
System Power Requirements	AC Input – Universal AC power supply: 100 to 249 VAC, 50/60Hz, 2A max.
Display Specifications	8" (20.32cm) Color WVGA LCD touch screen display
Connectivity Methods	Ethernet, Web Browser, Modem, Fax, Serial
Data Storage Features	SD card
Software Security Features	Centralized Device Management to protect your network of TLS-4XX consoles
Custom User Access	Front Panel Display control through user specific log-in; User defined roles to restrict access / functionality. Screen permissions can be limited to view, edit, perform
System Security	<ol style="list-style-type: none"> 1. Partitioned Ethernet Ports that can be used to separate user network from the internet 2. Port availability control: SSH Port (22), HTTPS Port (443), Serial Command Port (10001) 3. Reassign Port Numbers (i.e., HTTPS on 50443) 4. System Integrator CVE Scans & Fixes 5. Periodic System Updates to protect against persistent threats
Customized Alarm Features	Customizable for all alarms
Approvals	UL cUL, ATEX, IECEx, NEPSI, FCC, FMC, PESO, ANZEx, ULC, INMETRO, IQC, EAC, NWGLDE, and CEN
Third Party Evaluations	http://www.nwglde.org/evals/veeder_root_zf.html
Product Installation Guide	https://www.veeder.com/us/technical-document-library

System Compatibilities Guide

Feature/Console	TLS-450PLUS	Feature/Console	TLS-450PLUS	TLS-450PLUS with TLS-XB**
CONSOLE DESIGN		DATA COMMUNICATIONS		
Modular/Expandable Features	•	RS-232	5	5
LCD with Touch Screen (optional)	8" WVGA Color	RS-485	3	3
Integral Roll Printer	Optional	Fax Transmittal (SiteFax)	Optional	Optional
Universal Power Supply	•	External USB 2.0	2	2
INVENTORY CONTROL		Ethernet Ports	3	3
Graphical Inventory Status	•	International Forecourt Standards Forum (IFSF)	1	1
Complete Inventory Reports	•	SYSTEM CAPABILITIES		
Programmable Auto Report Times	•	Manifold Tank Capability (Line & Siphon)	•	•
Inventory Increase Report	•	Height-Based Pump Priority Control for Manifoldded Tanks	•	•
Timed Sudden Loss Detection	Optional	Pump Alternate on the Fly	•	•
BUSINESS INVENTORY RECONCILIATION		Self-Diagnostics	•	•
Shift-Based Reconciliation	Optional	Emergency Generator Capability	•	•
Reconciliation by Tank	Optional	Up to 3 Years Data Storage	•	•
TANK CALIBRATION		FAX Notification On-Time or Event	Optional	Optional
Multi-Pass Tank Calibration	Optional	Email Notification On-Time or Event	•	•
Single-Pass / Metered Drop	Optional	LCD with Touch Screen	Optional	Optional
Limited Range Calibration	Optional	On-Board Help	•	•
Supports Multiple Tank Charts per Tank	Optional	Custom Help	•	•
Supports Multiple Line Manifold Tanks	Optional	Custom Alarms	•	•
Graphical / Text Calibration Diagnostics	Optional	Environmental Reports (Compliance Reports Summary)	•	•
Automatic and Manual Meter Mapping	Optional	Sensor Reports	•	•
IN-TANK LEAK TEST		Sensor History Report by Period, Month, Week or Custom	•	•
0.1 GPH Tank Tightness Testing	•	Web-Enabled	•	•
0.2 GPH Tank Tightness Testing	•	System Duplicate	•	•
Continuous Statistical Leak Detection	Optional	SYSTEM CAPACITIES*		
Selectable Test Rates	•	Inputs	64	256
Programmable Automatic Test Schedules	•	In-Tank Probes (Including Density)	64	64
PASS, FAIL, or INVALID Indicators	•	In-Tank Probes with BIR	32	32
LINE LEAK DETECTION		Digital Pressurized Line Leak Detectors (Additional Software Req'd)	15	16
Integral Line Leak Detector	Optional	2-WIRE SENSORS		
Programmable Line Test Features	Optional	Magnetostrictive Discriminating Level Indicating Sump Sensor	64	99
INTERSTITIAL/SUMP LEAK SENSING		Discriminating Dispenser Pan & Containment Sensors	64	99
Tank Annulus	•	Solid-State Non-Discr. Dispenser Pan & Containment Sensors	64	99
Sump	•	Sump Sensors	64	99
Dispenser Pan	•	Position Sensitive Pan/Sump Sensor	64	99
Mag Sump	•	Interstitial Sensor for Fiberglass Tanks	64	99
Sensor Location Identifiers	•	Solid-State Discr. Interstitial Sensors for Fiberglass Tanks	64	99
VAPOR WELL MONITORING		Alt. Ethanol Fluid Interstitial Sensors for Fiberglass Tanks	64	99
Hydrocarbon Vapor Detection	•	Interstitial Sensors for Steel Tanks	64	99
High Water Level Alarm	•	Microsensors	64	99
GROUNDWATER MONITORING		Position Sensitive Interstitial Sensor for Steel Tanks	64	99
Hydrocarbon Liquid Detection	•	Alt. Ethanol Fluid Solid-State Interstitial Sensor for Steel Tanks	64	99
Low Water Alarm	•	Hydrostatic Sensors for Brine-Filled Double-Wall Tanks	64	99
AIR VAPOR MONITORING		Hydrostatic Sensor for Brine-Filled Double-Wall Sumps	64	99
Vapor Collection Monitor	Optional	Oil Water Separator Sensor	64	99
ALARMS		3-WIRE SENSORS		
Leak	•	Solid-State Discr. Dispenser Pan & Containment Sump Sensors	32	99
Overflow	•	Groundwater Sensor	32	99
High Level	•	Vapor Sensor for Monitoring Wells	32	99
Sudden Loss	•	INPUT & OUTPUT		
High Water	•	Output Relays	21	32
Low Inventory	•	External Inputs Low Voltage	16	64
Programmable Alarm Limits	•	External Inputs High Voltage	20	32
		10-amp Relay	4	16

* Indicates the maximum number of devices the system can handle if all slots/ positions are filled with that type of device.

** TLS-450PLUS with (3) three TLS-XB boxes

Notice

Veeder-Root makes no warranty of any kind with regard to this publication, including, but not limited to, the implied warranties of merchantability and fitness for a particular purpose.

Veeder-Root shall not be liable for errors contained herein or for incidental or consequential damages in connection with the furnishing, performance, or use of this publication.

Veeder-Root reserves the right to change system options or features, or the information contained in this publication.

This publication contains proprietary information which is protected by copyright. All rights reserved. No part of this publication may be photocopied, reproduced, or translated to another language without the prior written consent of Veeder-Root.

Example Illustrations

Illustrations used in this guide for example sensor installations may contain components that are customer supplied and not included with the sensor. Please check with your Veeder-Root Distributor for recommended installation accessories.

Third Party Evaluations

Third party evaluations of the Veeder-Root sensors contained in this application guide can be found under the Veeder-Root vendor name on the National Work Group on Leak Detection Evaluations (NWGLDE) website:

<http://www.nwglde.org>



GILBARCO
VEEDER-ROOT

ENCORE

ENCORE[®] SERIES

FUEL DISPENSERS



CONTENTS

Encore 700 S	2
Encore 700 S Flex Fuel	4
Encore CNG	6
Encore Ultra-Hi DEF	8
Applause™ Media	10
Catlow® Hanging Hardware	12
Configurations	14

ENCORE® SERIES

FUEL DISPENSERS

Welcome to the line of Encore fueling dispensers, the most reliable and time-tested fueling technology on the market. In fact, Encore is the most popular dispenser in North America — with more pumps installed than any of the competition! Whether you're looking for industry-leading security, the highest reliability, a better alternative fuel offering, or a whole new way to market your brand, Encore has it.

Encore dispensers offer a broad range of products to accommodate all types of fuels from gasoline to diesel to alternative fuels and beyond:

- Encore 700 S
- Encore Flex Fuel
- Encore CNG
- Encore Ultra-Hi + DEF

As the technology leader, we've designed the Encore family to grow with you. Our modular approach provides the greatest runway to adapt to rapidly evolving forecourt technologies. We offer state-of-the-art options such as EMV-certified FlexPay™ Hybrid Card Reader, 10.4" color screens, and Applause™ Media at the pump. And, of course, our Passport® POS is fully integrated to work with your Encore® dispensers.*

So no matter which model or combination you choose, your investment will keep paying off for years to come. For more information call your local distributor or visit www.gilbarco.com.

*US ONLY

Encore 700 S



 **GILBARCO
VEEDER-ROOT**

 **ЛЕЕДЕВ-ВООЛ
СИВВАСКО**

TRUSTED

ENCORE® 700S

DISPENSERS

The industry's most trusted dispenser

Secure your competitive advantage and increase profits with Gilbarco Veeder-Root's Encore® 700 S — your best dispenser investment for today and tomorrow.

Highly secure, powerful CRIND® electronics build a flexible and innovative platform for your changing forecourt marketing and payment needs. Enjoy peace of mind with a leading foundation that is highly secure today and upgradeable to meet the payment security and technology needs of tomorrow.

RELIABLE	Gilbarco's proven and time-tested design guarantees most forecourts and widest range of conditions
FLEXIBILITY	Encore® 700 S offers most configurations and options to fit your forecourt
EMV-READY	The industry's most secure Encore 700 S is the cornerstone of Gilbarco's EMV® suite of products
EASY SERVICE	Engineered with easy access and quick turntime for servicing and maintenance
RICH MEDIA	Encore® 700 S runs a variety of marketing and rich multimedia programs including Applause TV at the pump.

NOTE: The dispenser shown on the left is the Encore 700S (3+0 Blender) dispenser



FLEXIBLE

ENCORE® FLEX FUEL

FLEX FUEL DISPENSERS

Encore® Flexible Fuel Dispensers



Your customers are demanding more and more alternative fuel options. Encore Flexible Fuel Dispensers help broaden your fuel offering while keeping the fueling experience simple and safe. With the industry's broadest set of flexible fuel options, the Encore NF Series offers up to five product selections from one fueling position. It's a smart investment that lets you maximize branding and sales opportunities, while keeping the number of tanks needed to a minimum. All with the unmatched durability and reliability you expect from the industry leader in flexible fuels. The NF4 is a Multi-Hose Hybrid Blender, allowing you to offer three grades of blended gasoline, as well as two additional blended grades of alternative fuel that blend through their own individual hoses. Combined with clear signage, this feature prevents mis-fueling at the pump.

The Encore Flexible Fuel dispenser comes with all the same selling tools and value-added options as a traditional Encore unit:

OPTIONS	Four different model configurations available
EMV-READY	No EMV worries with the Encore® Flex Fuel Dispensers
RICH MEDIA	Applause™ TV or Applause Media System on 10.4" color screen is available.

NOTE: The dispenser shown on the left is the Encore 700S (3+1+1 Blender) with Flex Fuel Option. May not be available in all areas.

SEAMLESS

ENCORE® CNG

C N G D I S P E N S E R S

Encore CNG Alternative Fueling

Offering alternative fuels? Look no further than the Encore® Dispenser line. With our Encore® CNG, it's never been easier to bring compressed natural gas (CNG) to your forecourt. Encore® CNG offers a familiar interface to your customers, a seamless experience from gasoline to CNG fueling, and provides you a seamless integration with your existing forecourt controller. It provides a safe, fast and complete fill with maximum flexibility and connectivity to the ANGI compression system.

SAFE, FAST, AND COMPLETE FILL

Temperature-compensated fill rate with optimized, electronically controlled software. Positive shut-off, actuated ball valves with hydrocarbon and motion sensors provide industry-leading safety.

SEAMLESS INTEGRATION

Ties to your existing forecourt controller — minimizes impact to your site payment network and saves the cost of a separate POS system.

REMOTE CONNECTIVITY

Integrates with the ANGI compression system to provide three possible tiers of remote monitoring and configuration capabilities. Increase your site uptime with our connectivity.

FAMILIAR INTERFACE

Increase throughput, streamline transactions, shorten wait time, and enhance your customer's experience with Encore's familiar interface and intuitive design. Available in 1- or 2-sided models.

MAXIMUM FLEXIBILITY

Configurable for 3-Bank or Direct-fill site configurations. One dispenser for hi-flow and standard flow applications — fill cars or buses from the same dispenser and increase throughput for your site.



 **GILBARCO
VEEDER-ROOT**

 **GILBARCO
VEEDER-ROOT**

THIS SALE
\$ **13.08**
5.430
GASOLINE GALLON EQUIVALENT





Price Per GGE **2.19**
PSI **20.19**
Start **Stop**

 **GILBARCO
VEEDER-ROOT**

 **VEEDER-ROOT
GILBARCO**



FASTER

ENCORE[®] ULTRA-HI + DEF

D I E S E L D I S P E N S E R S

Encore Master & Satellite Dispensers

Pump up to 60 gpm (227 lpm)* combined flow rate when using a master and satellite simultaneously – with all the convenience of pay-at-pump. It's the fastest way to pump and pay!

The truck stop environment requires rugged solutions that are both durable and reliable, because time is money to you and your customers. Gilbarco Veeder-Root's Ultra-Hi flow masters and satellites for retail truck stops are made to last and they cut in half the amount of time it takes to pump and pay. You can sell more fuel during busy periods and your customers get back on the road faster. Our Encore[®] models combine to offer the most rugged, economical and flexible choices for truck stop fueling.

FLEXIBLE CHOICES

A variety of configurations to provide many options for your fuel island layout

SAFE, FAST, AND COMPLETE FILL

Cuts in half the amount of time to pump and pay

SEAMLESS INTEGRATION

Familiar Encore[®] interface and fueling experience

EASY MODULAR UPGRADES

Encore[®] modular dispenser electronics make it easy to upgrade in the future

*Assumes 30 psi inlet pressure. Flow rate for master and satellite used separately is about 30 gpm (113 lpm) each. Actual results may vary.

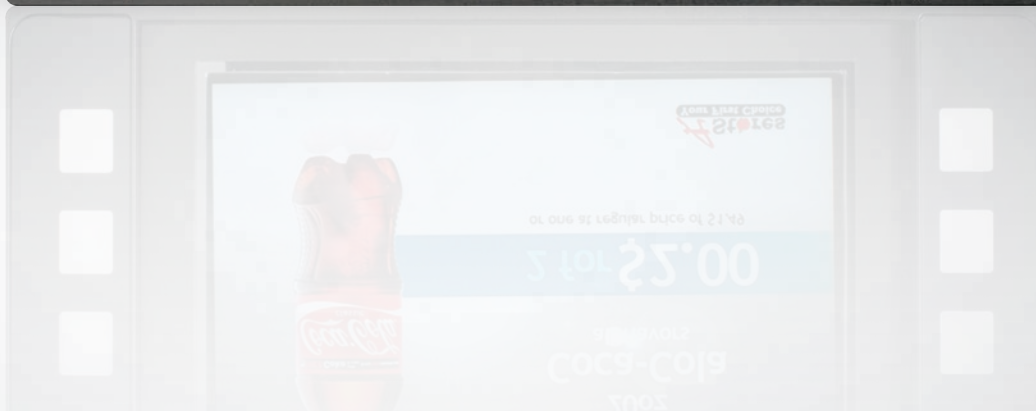
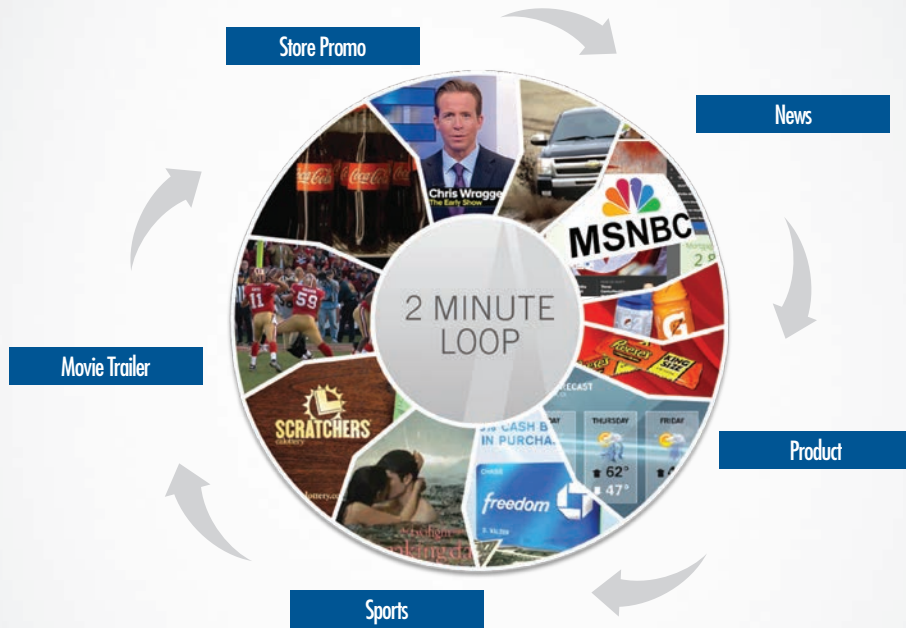

ADVERTISING

APPLAUSE™ MEDIA SYSTEM

MEDIA AT THE PUMP

Applause™ TV*

GROW IN-STORE SALES:

Applause™ TV brings multiple tools to drive consumers into the store through Gilbarco's partnership with GSTV Media. To grow in-store sales, you will benefit from:

- On-demand couponing — proven to show a 7% print rate
- Retailer-specific, customizable advertising by day part and location
- National advertising promotions
- Case studies have shown over 30% sales lift on promoted items

DIFFERENTIATE A SITE:

Applause™ TV differentiates a site from other sites by improving the site profile and providing an engaging fueling experience.

- Localized weather forecasts, news and sports updates
- 10.4" color screen with full-motion video and rich audio
- Connect with the community with amber alerts

Applause Media

Utilizing the same tools as Applause TV, Applause Media drives additional in-store sales and differentiates your brand by taking total control of your content loop. Engage directly with your customers through promotional giveaways, charity campaigns, targeted loyalty ads, local event promotion, and much more.

*May not be available in all areas.



HARDWARE

CATLOW HANGING HARDWARE

DO YOU NEED A NO-HASSLE SOLUTION TO HANGING HARDWARE ASSEMBLIES?

Catlow products are supported with world class customer service with 40 years of industry experience, making Catlow the best choice for your hanging hardware assembly needs.

- Bundled with Gilbarco Dispenser
- Full and Lower Cat-tail Assemblies Now Available

WHY USE CATLOW FOR YOUR HANGING HARDWARE ASSEMBLIES?

- Customized bundling with dispenser
- Fewer touches and logistics = cost savings. Save on Shipping. Save labor on assembling.
- No need to source with separate providers. Save on inventory management.
- Factory pre-assembled. Ease of making one connection into the outlet casting of the dispenser upon startup.
- Prevent accident due to installation error. Sold as a bundle with Dispenser to ensure compatibility. Pressure and Leak tested to avoid leaking over 5% saving with reduced failure rate.

FEATURES:

- 3/4" 1" Nozzle - Catlow offers a full line of nozzle products to suit your needs.
- CamTwist Magnetic Breakaway - Patented technology allows the breakaway to be twisted apart for maintenance & inspection which eliminates the need for a "remove by" date.
- Twister Swivel - Provides you with the benefits of both fuel weather compatibility, and has two 360-degree planes of rotation.

CONFIGURATIONS

OPTIONS

		Encore 700S	Encore S
Quality that lasts	Standard 2-year warranty includes labor	S	S
	4-year corrosion protection	S	S
	Angled hose outlets	S	S
	No pulse, no flow	S	S
	Encrypted Pulser	O	O
	Progressive lighting cues	S	S
	LED display lighting	S	S
	Brand View canopy	O	O
	Rounded and rectangular canopies	O	O
	Stainless steel sheathing	O	O
Better, brighter forecourt merchandising	5.7" Color display	S	N
	5.7" Monochrome display	N	S
	10.4" Color display	O	N
	Applause™ TV / Applause Media System	O	N
Industry-leading security	Hidden security clasp for pad lock	S	S
	Security door switches	O	O
	FlexPay™ Encrypting PIN Pad (EPP)	S	O
	FlexPay Secure Card Reader (SCR)	N	O
	FlexPay Hybrid Card Reader (HCR)	O	O
	Bar code scanner	O	N
	Contactless card reader	O	O
	Cash acceptor (US currency only)*	O	O
More flexible dispensing options	DEF + Diesel dispenser models	O	O
	Ultra-Hi Flow models	Y	Y
	Flex Fuel dispensers and blenders	Y	Y
	Up to 8 hoses (4 per side)	O	O

S = Standard Feature, O = Optional Feature, R = Available as Retrofit only, N = Not Available, Y = Available

* Not available on all model configurations

Type	Encore S	Encore 700S	Model	Description	Product Inlet	Grade Dis- pensed	Hoses Per Side	Activation Method	CIM Location Encore 700S Encore S	Meters
MPD	•	•	NA0	Dispenser 1-Grade	1	1	1	Lever	Center	2
	•	•	NA1	Dispenser 2-Grade	2	2	2	Lever	Center	4
	•	•	NA2	Dispenser 3-Grade	3	3	3	Lever	Center	6
	•	•	NA3	Dispenser 4-Grade	4	4	4	Lever	Center	8
	•	•	NC0	Pump 1-Grade	1	1	1	Lever	Center	2
	•	•	NC1	Pump 2-Grade	2	2	2	Lever	Center	4
	•	•	NC2	Pump 3-Grade	3	3	3	Lever	Center	6
	•	•	NC3	Pump 4-Grade	4	4	4	Lever	Center	8
Single Hose MPD	•	•	NG4	Dispenser 2-Grade	2	2	1	Grade Button	Center	4
	•	•	NG0	Dispenser 3-Grade	3	3	1	Grade Button	Center	6
	•	•	NG1	Single Hose + 1 Dispenser 4-Grade	4	4	2	Grade Button	Center	8
	•	•	NG5	Pump 2-Grade	2	2	1	Grade Button	Center	4
	•	•	NG2	Pump 3-Grade	3	3	1	Grade Button	Center	6
	•	•	NG3	Single Hose + 1 Pump 4-Grade	4	4	2	Grade Button	Center	8
X+0 Blender	•	•	NN1	Dispenser 3+0	2	3	1	Grade Button	Center	4
	•	•	NN2	Dispenser 4+0	2	4	1	Grade Button	Center	4
	•	•	NN3	Dispenser 5+0	2	5	1	Grade Button	Center	4
	•	•	NN5	Pump 3+0	2	3	1	Grade Button	Center	4
	•	•	NN6	Pump 4+0	2	4	1	Grade Button	Center	4
	•	•	NN7	Pump 5+0	2	5	1	Grade Button	Center	4
	X+1 Blender	•	•	NL0	Dispenser 2+1	3	3	2	Grade Button	Center
•		•	NL1	Dispenser 3+1	3	4	2	Grade Button	Center	6
•		•	NL2	Dispenser 4+1	3	5	2	Grade Button	Center	6
•		•	NL3	Blender Dispenser 3+1+1	4	5	3	Grade Button	Center	8
•		•	NL4	Pump 2+1	3	3	2	Grade Button	Center	6
•		•	NL5	Pump 3+1	3	4	2	Grade Button	Center	6
•		•	NL6	Pump 4+1	3	5	2	Grade Button	Center	6
Multi-Hose Blender		•	•	NJ0	Dispenser	2	3	3	Lever	Center
	•	•	NJ2	Multi-Hose + 1 Dispenser	3	4	4	Lever	Center	6
	•	•	NJ1	Pump	2	3	3	Lever	Center	4
	•	•	NJ3	Multi-Hose + 1 Pump	3	4	4	Lever	Center	6
	•	•	NJ4	Multi-Hose Hybrid Blender 3+2	4	5	3	Lever	Center	8
Ultra-Hi Flow	•	•	NP3	Master Dispenser 1-Grade	1 or 2	1	1	Lever	Center	1 or 2
	•	•	NP4	Combo Dispenser 1-Grade	2	1	1	Lever	Center	1
	•	•	NP5	Satellite Dispenser 1-Grade	1 or 2	1	1	Lever	Center	0
	•	•	NP6	Master Dispenser 2-Grade	2	2	2	Lever	Center	2
	•	•	NP8	Satellite Dispenser 2-Grade	2	2	2	Lever	Center	0
DEF	•	•	NA4	MPD Dispenser 1-Grade, Single-Side	1	1	1	Grade Button	Center	1
	•	•	NPA	Ultra-Hi DEF +1, Master for Diesel	2	2	2	Grade Button	Center	2
	•	•	NPB	Ultra-Hi Master/Satellite, Combo & DEF	2	2	2/1	Grade Button	Center	2
	•	•	NPC	Master Diesel 2-Grade, DEF 1-Side only	3	3	3/0	Grade Button	Center	3
Flexible Fuel Models for E85 and/or Biodiesel	•	•	NA0	MPD Dispenser 1-Grade	1	1	1	Lever	Center	1
	•	•	NA1	MPD Dispenser 2-Grade (1 or 2 alt)	2	2	2	Lever	Center	2
	•	•	NA2	MPD Dispenser 3-Grade (1 alt)	3	3	3	Lever	Center	3
	•	•	NA3	MPD Dispenser 4-Grade (1 or 2 alt)	4	4	4	Lever	Center	8
	•	•	NG0*	Single-Hose MPD Dispenser 3-Grade (1 alt)	3	3	2	Grade Button	Center	6
	•	•	NG1	Single-Hose + 1 MPD Dispenser 4-Grade (1 or 2 alt)	4	4	2	Grade Button	Center	8
	•	•	NL0*	2+1 Blender Dispenser (1 alt)	3	3	2	Grade Button	Center	6
	•	•	NJ2*	Multi-Hose Blender Dispenser +1	3	4	4	Grade Button	Center	6
	•	•	NJ4	Multi-Hose Hybrid Blender 3+2	4	5	3	Lever	Center	8
	•	•	NL1*	3+1 Blender Dispenser (1 alt)	3	4	2	Grade Button	Center	6
	•	•	NL2*	4+1 Blender Dispenser (1 alt)	3	5	2	Grade Button	Center	6
	•	•	NL3	Blender Dispenser 3+1+1	4	5	3	Grade Button	Center	8
	•	•	NN1*	Dispenser 3+0	2	3	1	Grade Button	Center	4
	•	•	NN2*	Dispenser 4+0	2	4	1	Grade Button	Center	4
•	•	NN3*	Dispenser 5+0	2	5	1	Grade Button	Center	4	

† Standard fuel can not be dispensed through the same hose as flexible fuels. ^ Pending UL Approval * UL Approved for E85

CONFIGURATIONS

OPTIONS

Type	Encore S	Encore 700 S	Model	Description	Product Inlet	Grade Dis-pensed	Hoses Per Side	Acti- vation Method	CIM Location Encore 700 S Encore S	Meters
Ultra-Hi Flow	•	•	NP3	Master Dispenser 1-Grade	1 or 2	1	1	Lever	Center	1 or 2
	•	•	NP4	Combo Dispenser 1-Grade	2	1	1	Lever	Center	1
	•	•	NP5	Satellite Dispenser 1-Grade	1 or 2	1	1	Lever	Center	0
	•	•	NP6	Master Dispenser 2-Grade	2	2	2	Lever	Center	2
	•	•	NP8	Satellite Dispenser 2-Grade	2	2	2	Lever	Center	0
DEF	•	•	NA4	MPD Dispenser 1-Grade, Single-Side	1	1	1	Grade Button	Center	1
	•	•	NPA	Ultra-Hi DEF +1, Master for Diesel	2	2	2	Grade Button	Center	2
	•	•	NPB	Ultra-Hi Master/Satellite, Combo & DEF	2	2	2/1	Grade Button	Center	2
	•	•	NPC	Master Diesel 2-Grade, DEF 1-Side only	3	3	3/0	Grade Button	Center	3
Flexible Fuel Models for E85 and/or Biodiesel	•	•	NA0	MPD Dispenser 1-Grade	1	1	1	Lever	Center	1
	•	•	NA1	MPD Dispenser 2-Grade (1 or 2 alt)	2	2	2	Lever	Center	2
	•	•	NA2	MPD Dispenser 3-Grade (1 alt)	3	3	3	Lever	Center	3
	•	•	NA3	MPD Dispenser 4-Grade (1 or 2 alt)	4	4	4	Lever	Center	8
	•	•	NG0*	Single-Hose MPD Dispenser 3-Grade (1 alt)	3	3	2	Grade Button	Center	6
	•	•	NG1	Single-Hose + 1 MPD Dispenser 4-Grade (1 or 2 alt)	4	4	2	Grade Button	Center	8
	•	•	NL0*	2+1 Blender Dispenser (1 alt)	3	3	2	Grade Button	Center	6
	•	•	NJ2*	Multi-Hose Blender Dispenser +1	3	4	4	Grade Button	Center	6
	•	•	NJ4	Multi-Hose Hybrid Blender 3+2	4	5	3	Lever	Center	8
	•	•	NL1*	3+1 Blender Dispenser (1 alt)	3	4	2	Grade Button	Center	6
	•	•	NL2*	4+1 Blender Dispenser (1 alt)	3	5	2	Grade Button	Center	6
	•	•	NL3	Blender Dispenser 3+1+1	4	5	3	Grade Button	Center	8
	•	•	NN1*	Dispenser 3+0	2	3	1	Grade Button	Center	4
•	•	NN2*	Dispenser 4+0	2	4	1	Grade Button	Center	4	
•	•	NN3*	Dispenser 5+0	2	5	1	Grade Button	Center	4	

NOTES



www.gilbarco.com

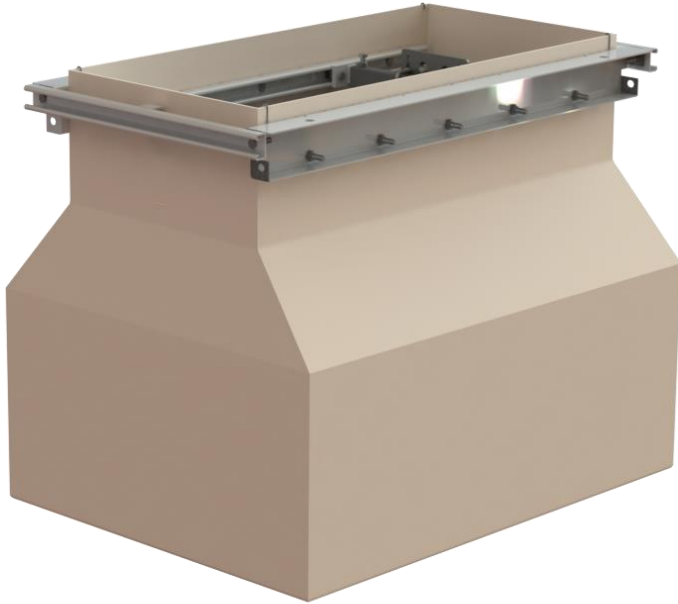

Product Shown
B1380-E30

About the Economy B1000 Series

One of the most cost competitive UDCs on the market, the B1000-E Series is an exclusive offer by Bravo that features electrical offsets on both ends of the UDC, providing flexible compatibility with modern station designs. The reduced metal work is galvanized while the splash lip is FRP, ensuring a distinct corrosion advantage over other designs.

Bravo Solution Center

Call or Text (323) 541-3851
orders@sbravo.com

SIZES

- 28" width at base

**See page 2 for dimension drawing and dimension chart*

MATERIAL

- Fiberglass
- Galvanized steel
- Quality FRP material won't deform like polyethylene

SPECIFICATIONS

- 28" width for more room inside the UDC for components
- Superior materials priced comparably to polyethylene UDCs
- Room for up to 10 conduits
- Pre-plumb options available
- 10-year corrosion warranty
- UL2447 listed



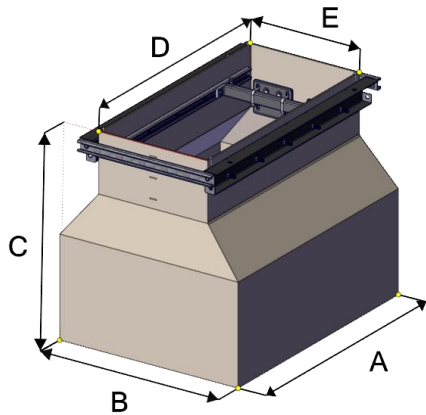

Bracket and Kits for Economy B1000 Series

Stabilizer Bar and Bracket Assembly		
Encore/Helix Wide	BK-1017	Boss-mount bracket for B1000 & stabilizer bar for 17". Wide assembly with hardware.
Ovation/Ovation High Speed/Helix Narrow/Pacific/Reliance/Select	BK-1015	Boss-mount bracket for B1000 & stabilizer bar for 15". Wide assembly with hardware.
Atlas/Bennett 3000	BK1011	Boss-mount bracket for B1000 & stabilizer bar for 11". Wide assembly with hardware.

Economy B1000 Series

Dispenser Model	Part #	A	B	C	D	E
Gilbarco Encore 300, 500, 700	B1380-E30	38.5"	28"	29.5"	37.5"	17"
Wayne Ovation (3+0) (3+1) up to 3 inlets	B1250-E30	37"	28"	29.5"	35"	14.75"
Wayne Helix Wide Frame	B1256-E30	38.5"	28"	29.5"	37.5"	17"
Wayne Helix Narrow Frame	B1242-E30	29"	28"	29.5"	27.5"	14.75"
Wayne Ovation High-speed Diesel/Ovation HL Series	B1254-E30	37"	28"	29.5"	35"	14.75"
Wayne Ovation High-speed Diesel/Ovation HS Series *	B1257-E30	29"	28"	29.5"	27.5"	14.75"
Wayne Reliance Select	B1210-E30	29"	28"	29.5"	27.5"	14.75"
Bennett Pacific	B1411-E30	37"	28"	29.5"	35"	14.75"
Bennett 3000 Big Fueler*	B1430-E30	19"	29.5"	29.5"	19"	11.5"
Gasboy Atlas	B1670-E30	19"	29.5"	29.5"	19"	11.5"

* Electrical Offsets on one end





Product Shown
B421-60-D-01

About the Doublewall Collar-Mount Tank Sumps with Lids

The octagon-shaped collar-mount doublewall tank sump is ideally configured for piping laid out in 45- and 90-degree angles. It is field height-adjustable and features a pour channel that makes for a simple PC slurry pour to join the sump base and top hat. It comes standard with a snap-lock lid with vertical O-ring seal to make it watertight with other available lid options. It is VPH compliant and can be laminated on to doublewall collars. When using Bravo doublewall collars with a pour channel, no field lamination is needed. It ships under 20" HG vacuum to ensure wall integrity.

Bravo Solution Center

Call or Text (323) 541-3851
orders@sbravo.com

SIZES

- 42" or 48" diameter
- 32" or 36" reducer

**See page 2 for dimension drawing and dimension chart*

MATERIAL

- Fiberglass

SPECIFICATIONS

- Quality FRP construction
- Split configuration is height-adjustable
- Fuel compatible resin doesn't require gel coat
- Doublewall is suitable for constant monitoring – triennial testing exempt
- 30-year corrosion warranty
- UL2447 listed



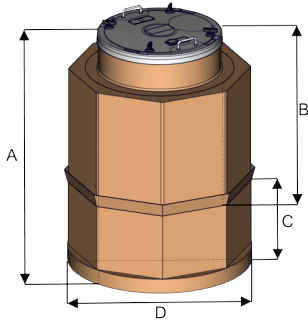

42" Diameter 42" Collar-mounted Doublewall VPH FRP

Sump Type	Part # with 32" SL lid	Part # with 36" SL lid	Part # with 32" Twist-Lock lid	Min/Max	A	B	C	D
Doublewall VPH 42" tall	B421-42-D-01	B421-42-D-02	B421-42-D-50	30" / 3'6"	42"	26"	16"	42"
Doublewall VPH 48" tall	B421-48-D-01	B421-48-D-02	B421-48-D-50	36" / 4'	48"	26"	22"	42"
Doublewall VPH 60" tall	B421-60-D-01	B421-60-D-02	B421-60-D-50	40" / 5'	60"	38"	22"	42"
Doublewall VPH 72" tall	B421-72-D-01	B421-72-D-02	B421-72-D-50	40" / 6'	72"	50"	22"	42"
Doublewall VPH 84" tall	B421-84-D-01	B421-84-D-02	B421-84-D-50	40" / 7'	84"	62"	22"	42"

48" Diameter 48" Collar-mounted Doublewall VPH FRP

Sump Type	Part # with 32" SL lid	Part # with 36" SL lid	Part # with 32" Twist-Lock lid	Min/Max	A	B	C	D
Doublewall VPH 42" tall	B481-42-D-01	B481-42-D-02	B481-42-D-50	30" / 3'6"	42"	26"	16"	48"
Doublewall VPH 48" tall	B481-48-D-01	B481-48-D-02	B481-48-D-50	36" / 4'	48"	26"	22"	48"
Doublewall VPH 60" tall	B481-60-D-01	B481-60-D-02	B481-60-D-50	40" / 5'	60"	38"	22"	48"
Doublewall VPH 72" tall	B481-72-D-01	B481-72-D-02	B481-72-D-50	40" / 6'	72"	50"	22"	48"
Doublewall VPH 84" tall	B481-84-D-01	B481-84-D-02	B481-84-D-50	40" / 7'	84"	62"	22"	48"

48" Diameter 42" Collar-mounted Doublewall VPH FRP

Sump Type	Part # with 32" SL lid	Part # with 36" SL lid	Part # with 32" Twist-Lock lid	Min/Max	A	B	C	D
Doublewall VPH 42" tall	B487-42-D-01	B487-42-D-02	B487-42-D-50	30" / 3'6"	42"	26"	16"	42"
Doublewall VPH 48" tall	B487-48-D-01	B487-48-D-02	B487-48-D-50	36" / 4'	48"	26"	22"	42"
Doublewall VPH 60" tall	B487-60-D-01	B487-60-D-02	B487-60-D-50	40" / 5'	60"	38"	22"	42"
Doublewall VPH 72" tall	B487-72-D-01	B487-72-D-02	B487-72-D-50	40" / 6'	72"	50"	22"	42"
Doublewall VPH 84" tall	B487-84-D-01	B487-84-D-02	B487-84-D-50	40" / 7'	84"	62"	22"	42"



A1100-T

Testable Overfill
Prevention Valve

Testable Overfill Prevention Valve

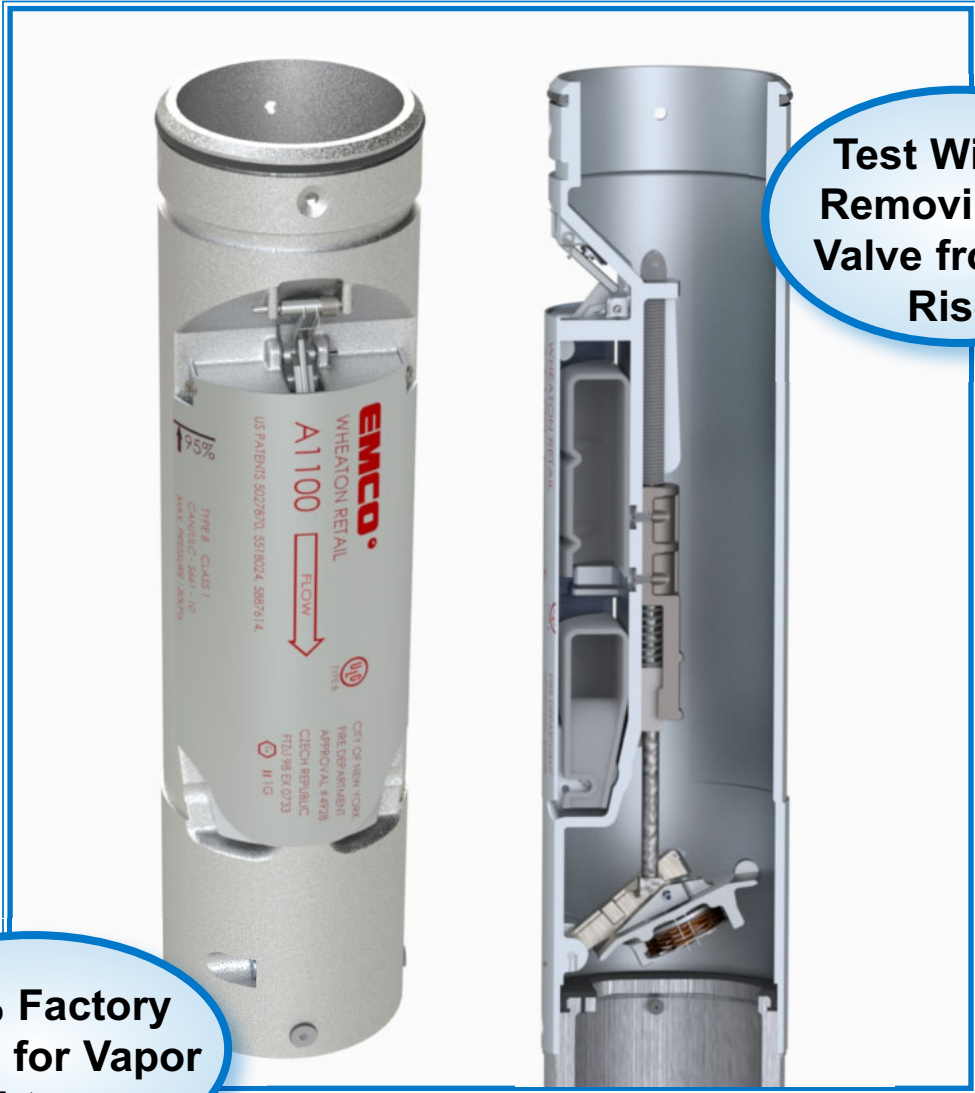

**100% Factory
Tested for Vapor
Tightness**

**Test Without
Removing the
Valve from the
Riser**

EMCO WHEATON RETAIL CORPORATION

2300 Industrial Park Drive • Wilson, North Carolina 27893 • 252-243-0150 • 252-243-4603 (fax) • www.emcoretail.com

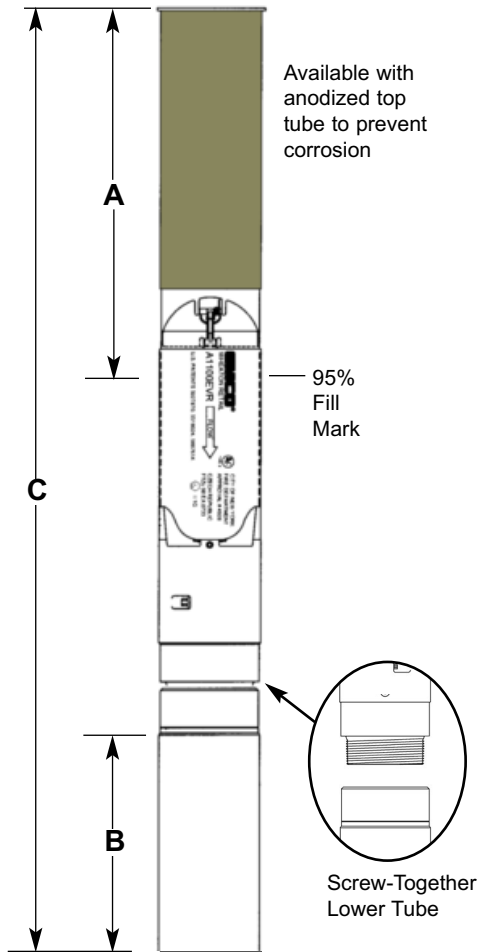

A1100-T Testable OPV

Emco's new A1100-T Testable Overfill Prevention Valve allows for quick and easy testing without removing the valve from the tank riser. Simply use the A0081-1100 Testing Rod to depress the test button installed on the valve, and shine a light inside the valve - if the reflective tape is visible, the valve is operational.

The testable A1100-T OPV uses the same proven technology as the A1100 OPV Series. Assemblies are factory welded and 100% factory tested. Bottom tube screws to top tube/valve assembly - No Epoxy. This saves time in the field and assures a vapor tight assembly to meet the EPA 40 CFR Part 63 requirements.

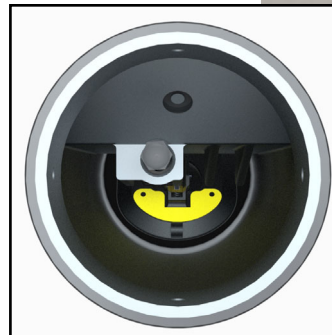

Testable Feature
Use A0081-1100 Testing Rod to depress test button and linkage.

Shine light down interior of valve (alternatively, snap a photo). If reflective tape is visible, valve is OK.

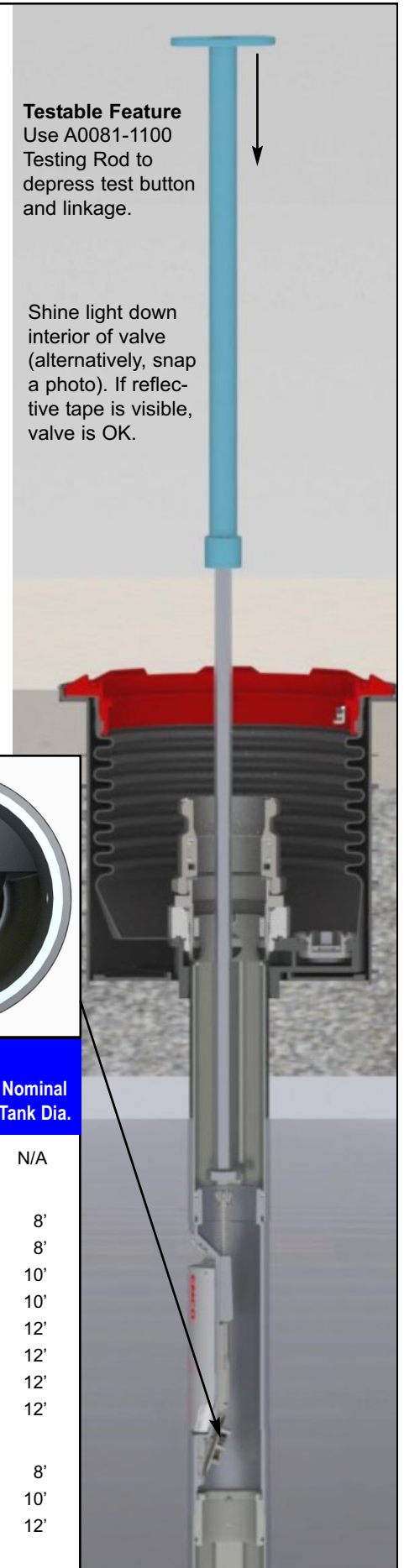

Model No.	Description	Top Tube Length A	Bottom Tube Length B	Overall Length C	Max. Burial Depth	Nominal Tank Dia.
A1100-010T	Testable Valve Only	N/A	N/A	N/A	N/A	N/A
Dual Point						
A1100EVR-055T	Testable Vapor-Tight OPV	70"	82"	167"	6.0'	8'
A1100EVR-055TCF*	Testable Vapor-Tight OPV	70"	82"	167"	6.0'	8'
A1100EVR-056T	Testable Vapor-Tight OPV	82"	92"	191"	7.0'	10'
A1100EVR-056TCF*	Testable Vapor-Tight OPV	82"	92"	191"	7.0'	10'
A1100EVR-057T	Testable Vapor-Tight OPV	82"	120"	217"	6.8'	12'
A1100EVR-057TCF*	Testable Vapor-Tight OPV	82"	120"	217"	6.8'	12'
A1100EVR-058T	Testable Vapor-Tight OPV	120"	120"	255"	10.0'	12'
A1100EVR-058TCF*	Testable Vapor-Tight OPV	120"	120"	255"	10.0'	12'
Coaxial - Self-Sealing (Adapter & cap included)						
A1100-085TP	Testable Vapor-Tight OPV	65"	82"	162"	5.4'	8'
A1100-086TP	Testable Vapor-Tight OPV	65"	94"	174"	5.3'	10'
A1100-087TP	Testable Vapor-Tight OPV	65"	120"	200"	5.1'	12'

*Anodized top tube

Emco Wheaton Retail Corporation

2300 Industrial Park Drive • Wilson, North Carolina 27893 • 252-243-0150 • 252-243-4603 (fax) • www.emcoretail.com

ATTACHMENT I

Initial and Continuing Training

Initial and Continuing Training

The release detection system at the facility will be a Veeder Root TLS-450 Plus. The system will also be equipped with CSLD Release Detection Software and inventory reconciliation. The system will have sump sensors installed in the submersible sump containment area to monitor sub pump, sump sensors installed in the dispenser sumps and tank interstitial sensors. The system will be equipped with electronic line leak detection for the product delivery lines. The system will be installed by a Veeder Root certified technician. The system will be installed in accordance with Veeder Root specifications and instructions. The system is UL listed and is third party certified for release detection under USEPA guidelines. The system has self- diagnostic programs to test and warn of failures of the external devices as well as internal electronics. The system has been tested by a Third Party and found to be compliant with USEPA requirements for release detection.

Annual maintenance of the system will be conducted to certify the function of all modules in the system.

On-site employees will monitor the system condition locally and remotely on a daily basis, with particular emphasis on any sensor alarms or release detection alarms as indicated on the panel of the system. In the case of any sensor or inventory alarm, employees will notify the Owner or General Manager who will make the determination of a proper course of action. Site employees are not authorized to reset or disable any alarm conditions on the system.

New facility employees will be trained in the proper operation and functional modes of the system. Ongoing reviews of the system operation will be presented to all employees to ensure operation and function status is understood.

Ongoing maintenance will be conducted by Texas Fuel Solutions, LLC personnel.



Operating And Maintaining Underground Storage Tank Systems

Practical Help And Checklists



Contents

How to Use This Booklet	1
Section 1 — Identifying The Equipment At Your UST Facility	3
Section 2 — Release Detection	5
Section 3 — Suspected Or Confirmed Releases	21
Section 4 — Spill And Overfill Protection	24
Section 5 — Corrosion Protection	34
Section 6 — Frequent Walk-Through Inspections	42
Section 7 — For More Information	44

DISCLAIMER

This document provides information on operating and maintaining underground storage tank (UST) systems. The document is not a substitute for U.S. Environmental Protection Agency regulations nor is it a regulation itself — it does not impose legally binding requirements.

For regulatory requirements regarding UST systems, refer to the federal regulations governing UST systems (40 CFR Part 280).

How To Use This Booklet

Who Should Read This Booklet?

This booklet is for owners and operators of underground storage tank systems (USTs).

You are responsible for making sure your USTs do not leak. This booklet can help you meet your UST responsibilities.

What Can This Booklet Help You Do?

- Identify and understand the operation and maintenance (O&M) procedures you need to follow routinely to make sure your USTs don't have leaks that damage the environment or endanger human health.
- Identify good O&M procedures you can use to avoid cleanup costs and liability concerns.
- Maintain useful records of your O&M.

Key Terms Used In This Booklet

An **UST** is an **underground storage tank and underground piping connected to the tank** that has at least 10 percent of its combined volume underground. The federal regulations apply only to USTs storing petroleum or certain hazardous substances.

O&M stands for **operation and maintenance procedures** that must be followed to keep USTs from causing leaks and creating costly cleanups.

Your UST System Is New Or Upgraded — Is That Enough?

Being new or upgraded is not enough. New and upgraded USTs are made of a complex collection of mechanical and electronic devices that can fail under certain conditions. These failures can be prevented or quickly detected by following routine O&M procedures. Having a new or upgraded UST system is a good start, but the system must be properly operated and continuously maintained to ensure that leaks are avoided or quickly detected.

What Should You Do With Each Section Of This Booklet?

Read through each section carefully and use the checklists to help you establish clear O&M procedures.

By identifying and understanding the O&M tasks you need to perform routinely, you will ensure timely repair or replacement of components when problems are identified.



How Can You Use The Following Checklists Effectively?

This booklet's pages are 3-hole punched and unbound so you can put all the materials in a handy 3-ring binder. You can easily remove any of the following checklists from the binder, reproduce them, and then fill them out.

You can select the specific mix of checklists that matches your UST facility. Once you have your select group of checklists together, make several copies that you can fill out periodically over time.

In this way you can keep track of your O&M activities and know that you've done what was necessary to keep your UST site safe and clean, avoiding any threats to the environment or nearby people as a result of costly and dangerous UST releases.

Use This Booklet Often — Effective O&M Requires Constant Vigilance.

Note: This booklet describes quality O&M practices put together by a work group of state and federal environmental regulators. This booklet is not a federal regulation nor legally binding, but it does provide useful information on effective O&M procedures. You should check with your state UST program for information on any additional or different O&M practices that may be required in your state. See Section 7 for contact information.

Section 1 — Identifying The Equipment At Your UST Facility

Determine what UST equipment you have at your facility by completing the checklist below. Note that each part of the checklist below refers you to the appropriate section of this O&M booklet for relevant information. After you have identified your equipment, proceed to the following sections to identify the O&M actions necessary for your specific UST system.

General Facility Information (optional)					
Facility Name					
Facility ID #					
Release Detection (See Section 2 for information on release detection)					
A. Release Detection for Tanks					
Check at least one for each tank:		Tank #1	Tank #2	Tank #3	Tank #4
Automatic Tank Gauging System					
Interstitial Monitoring (with secondary containment)					
Groundwater Monitoring					
Vapor Monitoring					
Inventory Control and Tank Tightness Testing (TTT)*					
Manual Tank Gauging Only **					
Manual Tank Gauging and Tank Tightness Testing (TTT)***					
Other Release Detection Method, such as SIR (please specify)					
* Allowed only for 10 years after upgrading or installing tank with corrosion protection. TTT required every 5 years.					
** Allowed only for tanks of 1,000 gallon capacity or less.					
*** Allowed only for tanks of 2,000 gallon capacity or less and only for 10 years after upgrading or installing tank with corrosion protection. TTT required every 5 years.					
B. Release Detection for Pressurized Piping					
Check at least one from A & B for each tank's piping:		Tank #1	Tank #2	Tank #3	Tank #4
A (Automatic Line Leak Detectors)	Automatic Flow Restrictor				
	Automatic Shutoff Device				
	Continuous Alarm				
B	Annual Line Tightness Test				
	Monthly Monitoring*				
* Monthly Monitoring for piping includes Interstitial Monitoring, Vapor Monitoring, Groundwater Monitoring, and other accepted methods (such as SIR and Electronic Line Leak Detectors)					
C. Release Detection for Suction Piping					
Check at least one for each tank's piping:		Tank #1	Tank #2	Tank #3	Tank #4
Line Tightness Testing Every Three Years					
Monthly Monitoring*					
No Release Detection Required For Safe Suction **					
* Monthly Monitoring for piping includes Interstitial Monitoring, Vapor Monitoring, Groundwater Monitoring, and SIR					
** No release detection required only if it can be verified that you have a safe suction piping system with the following characteristics:					
1) Only one check valve per line located directly below the dispenser;					
2) Piping sloping back to the tank; and					
3) System must operate under atmospheric pressure.					

Spill and Overfill Protection (See Section 4 for more information)				
Check for each tank:	Tank #1	Tank #2	Tank #3	Tank #4
Spill Catchment Basin/ Spill Bucket				
Check at least one overfill device for each tank:				
Automatic Shutoff Device				
Overfill Alarm				
Ball Float Valve				
Corrosion Protection (See Section 5 for more information)				
A. Corrosion Protection for Tanks				
Check at least one for each tank:	Tank #1	Tank #2	Tank #3	Tank #4
Coated and Cathodically Protected Steel				
Noncorrodible Material (such as Fiberglass Reinforced Plastic)				
Steel Jacketed or Clad with Noncorrodible Material				
Cathodically Protected Noncoated Steel*				
Internally Lined Tank*				
Cathodically Protected Noncoated Steel and Internally Lined Tank*				
Other Method Used to Achieve Corrosion Protection (please specify):				
* These options may be used only for tanks installed before December 22, 1988.				
B. Corrosion Protection for Piping				
Check at least one for each:	Tank #1	Tank #2	Tank #3	Tank #4
Coated and Cathodically Protected Steel				
Noncorrodible Material (such as Fiberglass Reinforced Plastic or Flexible Plastic)				
Cathodically Protected Noncoated Metal*				
Other Method Used to Achieve Corrosion Protection (please specify):				
* This option may be used only for piping installed before December 22, 1988.				

Any Problems Filling Out This Checklist?

If you have trouble filling out this checklist or any following checklist, remember these sources of assistance you can contact:

- Your UST contractor, the vendor of your equipment, and the manufacturer of your UST equipment should be ready to help you. Look through your records for contact information. You may also want to use some of the industry contacts and other contact information provided in Section 7.
- Your state regulatory agency may be able to help you identify equipment or sources of information about your UST equipment. You should, in any event, make yourself aware of any ways in which your state may have additional or different O&M procedures than those presented in this booklet. See Section 7 for state agency contact information.

Section 2 — Release Detection

What Is Release Detection?

You must be able to determine at least every 30 days whether or not your tank and piping are leaking by using proper release detection methods.

Your release detection method must be able to detect a release from any portion of the tank and connected underground piping that routinely contains product.

Release detection must be installed, calibrated, operated, and maintained according to the manufacturer's instructions.

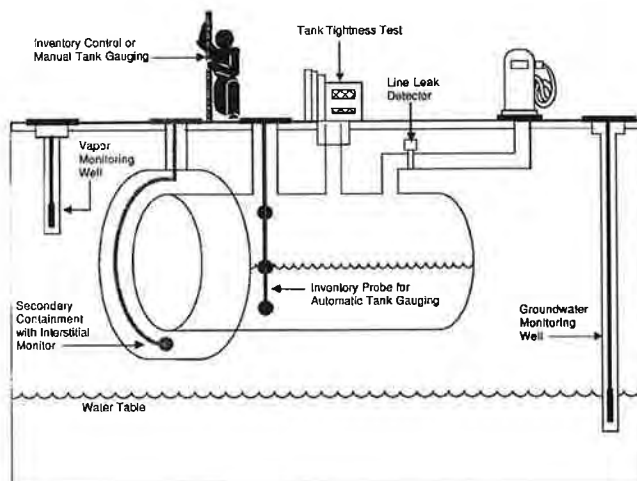

Do You Know If Your Release Detection Is Certified To Work At Your UST Site?

Release detection must meet specific performance requirements. You should have documentation from the manufacturer, vendor, or installer of your release detection equipment showing certification that it can meet performance requirements.

Some vendors or manufacturers supply their own certification, but more often an impartial "third party" is paid to test the release detection equipment and certify that performance requirements are met. An independent workgroup of release detection experts periodically evaluates all third-party certifications, thus providing a free and reliable list of evaluations of third-party certifications for various release detection equipment. Frequently updated, this list is available on the Internet at <http://www.nwglde.org/> (the publication's title is **List Of Leak Detection Evaluations For Underground Storage Tank Systems**). If you can't find the certification anywhere, contact your state regulatory agency (see Section 7 for contact information).

By checking the certification, you may discover the method you use has not been approved for use with the type of tank or piping you have or the type of product being stored. For example, you may learn from the certification that your method won't work with manifolded tanks, certain products, high throughput, or with certain tank sizes.

That's why you need to make sure your release detection method has clear certification that it will work effectively at your site with its specific characteristics.

How Can You Make Sure Your Leak Detection Method Is Working At Your UST Site?

If you don't understand your O&M responsibilities and don't know what O&M tasks you must routinely perform, you may allow your UST site to become contaminated — then you will face cleanup costs and associated problems.

To avoid these problems use the checklists on the following pages that describe each type of leak detection method, discuss actions necessary for proper O&M, and note the records you should keep.

Locate the methods of release detection you are using at your facility, review these pages, and periodically complete the checklist. You might want to copy a page first and periodically fill out copies later.

If you have questions about your release detection system, review your owner's manual or call the vendor of your system. Your state or local regulatory agency may be able to provide assistance as well.

You will find leak detection recordkeeping forms in the following pages of this Section. Keeping these records increases the likelihood that you are conducting good O&M and providing effective release detection at your UST site. For example, see page 20 for a 30-Day Release Detection Monitoring Record.

If you ever suspect or confirm a leak, refer to Section 3. **Never ignore leak detection alarms or failed leak detection tests. Treat them as potential leaks!**

Automatic Tank Gauging (ATG) Systems (for tanks only)	
Description Of Release Detection	An automatic tank gauging (ATG) system consists of a probe permanently installed in a tank and wired to a monitor to provide information on product level and temperature. ATG systems automatically calculate the changes in product volume that can indicate a leaking tank.
Have Certification For Your Release Detection Method	<ul style="list-style-type: none"> ❑ Make sure your ATG system is certified for the types of tanks and stored contents on which the ATG system is used. Most manufacturers have their leak detection devices tested and certified by a third party to verify that their equipment meets specific performance requirements set by regulatory agencies. If you don't have certified performance claims, have the manufacturer provide them to you.
Perform These O&M Actions	<ul style="list-style-type: none"> ❑ Use your ATG system to test for leaks at least every 30 days. Most systems are already programmed by the installer to run a leak test periodically. If your system is not programmed to automatically conduct the leak test, refer to your ATG system manual to identify which buttons to push to conduct the leak test. Testing more often than monthly can catch leaks sooner and reduce cleanup costs and problems. ❑ Make sure that the amount of product in your tank is sufficient to run the ATG leak test. The tank must contain a minimum amount of product to perform a valid leak detection test. One source for determining that minimum amount is the certification for your leak detection equipment (as discussed above). ❑ Frequently test your ATG system according to the manufacturer's instructions to make sure it is working properly. Don't assume that your release detection system is working and never needs checking. Read your owner's manual, run the appropriate tests, and see if your ATG system is set up and working properly. Most ATG systems have a test or self-diagnosis mode that can easily and routinely run these checks. ❑ If your ATG ever fails a test or indicates a release, see Section 3 of this booklet for information on what to do next. ❑ Periodically have a qualified UST contractor, such as the vendor who installed your ATG, service all the ATG system components according to the manufacturer's service instructions. Tank probes and other components can wear out and must be checked periodically. Many vendors recommend or require this maintenance activity at least annually. ❑ Check your ATG system owner's manual often to answer questions and to make sure you know the ATG's operation and maintenance procedures. Call the ATG manufacturer or vendor for a copy of the owner's manual if you don't have one. ❑ Make sure employees who run, monitor, or maintain the release detection system know exactly what they have to do and to whom to report problems. Develop and maintain regular training programs for all employees.
Keep These O&M Records	<ul style="list-style-type: none"> ❑ Keep results of your ATG system tests for at least 1 year. Your monitoring equipment may provide printouts that can be used as records. Unless you are recording actual release detection results at least every 30 days and maintaining records for at least 1 year, you are not doing leak detection right. ❑ Keep all records of calibration, maintenance, and repair of your release detection equipment for at least 1 year. ❑ Keep all performance claims supplied by the installer, vendor, or manufacturer for at least 5 years. These records include the certification of your leak detection equipment described above.

Secondary Containment With Interstitial Monitoring

(for tanks & piping)

Description Of Release Detection	<p>Secondary containment is a barrier between the portion of an UST system that contains product and the outside environment. Examples of secondary containment include an outer tank or piping wall, an excavation liner, and a bladder inside an UST. The area between the inner and outer barriers — called the interstitial space — is monitored manually or automatically for evidence of a leak.</p>
Have Certification For Your Release Detection Method	<ul style="list-style-type: none"> ❑ Make sure your interstitial monitoring equipment and any probes are certified for the types of tanks, piping, and stored contents on which the release detection system is used. Most manufacturers have their leak detection devices tested and certified by a third party to verify that their equipment meets specific performance requirements set by regulatory agencies. If you don't have certified performance claims, have the manufacturer provide them to you.
Perform These O&M Actions	<ul style="list-style-type: none"> ❑ Use your release detection system to test for leaks at least every 30 days. Testing more often than monthly can catch leaks sooner and reduce cleanup costs and problems. ❑ Frequently test your release detection system according to the manufacturer's instructions to make sure it is working properly. Don't assume that your release detection system is working and never needs checking. Read your owner's manual, run the appropriate tests, and see if your system is set up and working properly. Some interstitial monitoring systems have a test or self-diagnosis mode that can easily and routinely run these checks. ❑ If your interstitial monitoring ever fails a test or indicates a release, see Section 3 of this booklet for information on what to do next. ❑ Periodically have a qualified UST contractor, such as the vendor who installed your release detection system, service all the system components according to the manufacturer's service instructions. Tank probes and other components can wear out and must be checked periodically. Many vendors recommend or require this maintenance activity at least annually. ❑ Keep interstitial monitoring access ports clearly marked and secured. ❑ Check your interstitial monitoring system owner's manual often to answer questions and to make sure you know the system's O&M procedures. Call the system's vendor or manufacturer for a copy of the owner's manual if you don't have one. ❑ Make sure employees who run, monitor, or maintain the release detection system know exactly what they have to do and to whom to report problems. Develop and maintain regular training programs for all employees.
Keep These O&M Records	<ul style="list-style-type: none"> ❑ Keep results of your release detection system tests for at least 1 year. Your monitoring equipment may provide printouts that can be used as records. Unless you are recording actual release detection results at least every 30 days and maintaining records for at least 1 year, you are not doing leak detection right. ❑ Keep all records of calibration, maintenance, and repair of your release detection equipment for at least 1 year. ❑ Keep all performance claims supplied by the installer, vendor, or manufacturer for at least 5 years. These records include the certification of your leak detection equipment described above.

Statistical Inventory Reconciliation (SIR) (for tanks & piping)	
Description Of Release Detection	SIR is typically a method in which a trained professional uses sophisticated computer software to conduct a statistical analysis of inventory, delivery, and dispensing data. You must supply the professional with data every month. There are also computer programs that enable an owner/operator to perform SIR. In either case, the result of the analysis may be pass, inconclusive, or fail.
Have Certification For Your Release Detection Method	<ul style="list-style-type: none"> <input type="checkbox"/> Make sure your SIR vendor's methodology is certified for the types of tanks, piping, and product on which you use SIR. Most vendors have their leak detection methodology tested and certified by a third party to verify that their equipment meets specific performance requirements set by regulatory agencies. If you don't have certified performance claims, have the vendor provide them to you.
Perform These O&M Actions	<ul style="list-style-type: none"> <input type="checkbox"/> Supply daily inventory data to your SIR vendor (as required) at least every 30 days. The vendor will provide you with your leak detection results after the statistical analysis is completed. Otherwise, use your computer software at least every 30 days to test your tank for leaks. <input type="checkbox"/> See Section 3 of this manual if your UST system fails a leak test. <input type="checkbox"/> If you receive an inconclusive result, you must work with your SIR vendor to correct the problem and document the results of the investigation. An inconclusive result means that you have not performed leak detection for that month. If you cannot resolve the problem, treat the inconclusive result as a suspected release and refer to Section 3. <input type="checkbox"/> If you use an ATG system to gather data for the SIR vendor or your software, periodically have a qualified UST contractor, such as the vendor who installed your ATG, service all the ATG system components according to the manufacturer's service instructions. Tank probes and other components can wear out and must be checked periodically. Many vendors recommend or require this maintenance activity at least annually. Do this according to manufacturer's instructions. See the checklist for ATG systems on page 7. <input type="checkbox"/> If you stick your tank to gather data for the SIR vendor or your software, make sure your stick can measure to one-eighth of an inch and can measure the level of product over the full range of the tank's height. You should check your measuring stick periodically to make sure you can read the markings and numbers and that the bottom of the stick is not worn. <input type="checkbox"/> Make sure employees who run, monitor, or maintain the release detection system know exactly what they have to do and to whom to report problems. Develop and maintain regular training programs for all employees.
Keep These O&M Records	<ul style="list-style-type: none"> <input type="checkbox"/> Keep results of your SIR tests for at least 1 year. Unless you are keeping records of the 30-day release detection results and maintaining those records for at least 1 year, you are not doing leak detection right. <input type="checkbox"/> Keep all vendor performance claims for at least 5 years. This includes the certification of the SIR method discussed above. <input type="checkbox"/> If you use an ATG system, keep all records of calibration, maintenance, and repair of your release detection equipment for at least 1 year. <input type="checkbox"/> Keep the records of investigations conducted as a result of any monthly monitoring conclusion of inconclusive or fail for at least 1 year. This may include the results of a tightness test performed during the investigation or a re-evaluation based on corrected delivery or dispenser data.

Vapor Monitoring (for tanks & piping)	
Description Of Release Detection	Vapor monitoring measures product vapors in the soil at the UST site to check for a leak. A site assessment must determine the number and placement of monitoring wells that make sure a release is detected. NOTE: vapor monitors will not work well with substances that do not easily vaporize (such as diesel fuel).
Have Certification For Your Release Detection Method	<ul style="list-style-type: none"> <input type="checkbox"/> Make sure your vapor monitoring equipment is certified for the types of stored contents on which the release detection system is used. Most manufacturers have their leak detection devices tested and certified by a third party to verify that their equipment meets specific performance requirements set by regulatory agencies. If you don't have certified performance claims, have the manufacturer provide them to you.
Perform These O&M Actions	<ul style="list-style-type: none"> <input type="checkbox"/> Use your release detection system to test for leaks at least every 30 days. Testing more often than monthly can catch leaks sooner and reduce cleanup costs and problems. Be sure you check all of your vapor monitoring wells. <input type="checkbox"/> See Section 3 of this manual if your UST system fails a leak test. <input type="checkbox"/> Frequently test your release detection system according to the manufacturer's instructions to make sure it is working properly. Don't assume that your release detection system is working and never needs checking. Some electronic vapor monitoring systems have a test or self-diagnosis mode. If you have components (such as monitoring equipment, probes or sensors) for your vapor monitoring system, read your manual and test your equipment to see if it is working properly. <input type="checkbox"/> Periodically have a qualified UST contractor, such as the vendor who installed your release detection system, service all the system components according to the manufacturer's service instructions. Probes and other components can wear out and must be checked periodically. Many vendors recommend or require this maintenance activity at least annually. <input type="checkbox"/> Keep your vapor monitoring wells clearly marked and secured. <input type="checkbox"/> Check your vapor monitoring system owner's manual often to answer questions and to make sure you know the system's operation and maintenance procedures. Call the system's vendor or manufacturer for a copy of the owner's manual if you don't have one. <input type="checkbox"/> Make sure employees who run, monitor, or maintain the release detection system know exactly what they have to do and to whom to report problems. Develop and maintain regular training programs for all employees.
Keep These O&M Records	<ul style="list-style-type: none"> <input type="checkbox"/> Keep results of your release detection system tests for at least 1 year. Your monitoring equipment may provide printouts that can be used as records. Unless you are recording actual release detection results at least every 30 days and maintaining records for at least 1 year, you are not doing leak detection right. <input type="checkbox"/> Keep all records of calibration, maintenance, and repair of your release detection equipment for at least 1 year. <input type="checkbox"/> Keep all performance claims supplied by the installer, vendor, or manufacturer for at least 5 years. These records include the certification of your leak detection equipment described above.

Groundwater Monitoring (for tanks & piping)

Description Of Release Detection	Groundwater monitoring looks for the presence of liquid product floating on the groundwater at the UST site. A site assessment must determine the number and placement of monitoring wells that make sure a release is detected. NOTE: this method cannot be used at sites where groundwater is more than 20 feet below the surface.
Have Certification For Your Release Detection Method	<ul style="list-style-type: none"> <input type="checkbox"/> Make sure any automated groundwater monitoring equipment is certified for the types of stored contents on which the release detection system is used. Most manufacturers have their leak detection devices tested and certified by a third party to verify that their equipment meets specific performance requirements set by regulatory agencies. If you don't have certified performance claims, have the manufacturer provide them to you. (Manual devices such as bailers are not generally certified.)
Perform These O&M Actions	<ul style="list-style-type: none"> <input type="checkbox"/> Use your release detection system to test for leaks at least every 30 days. Testing more often than monthly can catch leaks sooner and reduce cleanup costs and problems. Be sure you check all of your groundwater monitoring wells. <input type="checkbox"/> See Section 3 of this manual if your UST system fails a leak test. <input type="checkbox"/> Frequently test your automated release detection system according to the manufacturer's instructions to make sure it is working properly. Don't assume that your release detection system is working and never needs checking. Some electronic groundwater monitoring systems have a test or self-diagnosis mode. If you have components (such as monitoring equipment, probes or sensors) for your groundwater monitoring system, read your manual and test your equipment to see if it is working properly. Manual devices should be periodically checked to make sure they are working properly. <input type="checkbox"/> Periodically have a qualified UST contractor, such as the vendor who installed your release detection system, service all the system components according to the manufacturer's service instructions. Probes and other components can wear out and must be checked periodically. Many vendors recommend or require this maintenance activity at least annually. <input type="checkbox"/> Keep your groundwater monitoring wells clearly marked and secured. <input type="checkbox"/> Check your groundwater monitoring system owner's manual often to answer questions and to make sure you know the system's operation and maintenance procedures. Call the system's vendor or manufacturer for a copy of the owner's manual if you don't have one. <input type="checkbox"/> Make sure employees who run, monitor, or maintain the release detection system know exactly what they have to do and to whom to report problems. Develop and maintain regular training programs for all employees.
Keep These O&M Records	<ul style="list-style-type: none"> <input type="checkbox"/> Keep results of your release detection system tests for at least 1 year. Your monitoring equipment may provide printouts that can be used as records. Unless you are recording actual release detection results at least every 30 days and maintaining records for at least 1 year, you are not doing leak detection right. <input type="checkbox"/> Keep all records of calibration, maintenance, and repair of your release detection equipment for at least 1 year. <input type="checkbox"/> Keep all performance claims supplied by the installer, vendor, or manufacturer for at least 5 years. These records include the certification of your leak detection equipment described above.

Inventory Control And Tank Tightness Testing (for tanks only)

<p>Description Of Release Detection</p>	<p>This temporary method combines monthly inventory control with periodic tank tightness testing. Inventory control involves taking measurements of tank contents and recording the amount of product pumped each operating day, measuring and recording tank deliveries, and reconciling all this data at least once a month. This combined method also includes tightness testing, a sophisticated test performed by trained professionals.</p> <p><i>NOTE: This combination method can only be used temporarily for up to 10 years after installing a new UST or for up to 10 years after your tank meets the corrosion protection requirements.</i></p>
<p>Have Certification For Your Release Detection Method</p>	<ul style="list-style-type: none"> <input type="checkbox"/> Make sure your tank tightness testing method is certified for the types of tanks and stored contents on which the tightness test is used. Most tightness test methods are certified by a third party to verify that they meet specific performance requirements set by regulatory agencies. If you don't have certified performance claims, have the tightness tester provide them to you.
<p>Perform These O&M Actions</p>	<ul style="list-style-type: none"> <input type="checkbox"/> Take inventory readings and record the numbers at least each day that product is added to or taken out of the tank. You may want to use the Daily Inventory Worksheet provided for you on the next page. <input type="checkbox"/> Reconcile the fuel deliveries with delivery receipts by taking inventory readings before and after each delivery. Record these readings on a Daily Inventory Worksheet (see next page). <input type="checkbox"/> Reconcile all your data at least every 30 days. Use a Monthly Inventory Record (see page 14 for an example). <input type="checkbox"/> Have a tank tightness test conducted at least every 5 years. This testing needs to be conducted by a professional trained in performing tank tightness testing. <input type="checkbox"/> See Section 3 of this manual if your tank fails a tightness test or if fails two consecutive months of inventory control. <input type="checkbox"/> Ensure that your measuring stick can measure to the nearest one-eighth inch and can measure the level of product over the full range of the tank's height. You should check your measuring stick periodically to make sure that you can read the markings and numbers and that the bottom of the stick is not worn. <input type="checkbox"/> Ensure that your product dispenser is calibrated according to local standards or to an accuracy of 6 cubic inches for every 5 gallons of product withdrawn. <input type="checkbox"/> Measure the water in your tank to the nearest one-eighth inch at least once a month and record the results on the reconciliation sheet. You can use a paste that changes color when it comes into contact with water. <input type="checkbox"/> Make sure employees who run, monitor, or maintain the release detection system know exactly what they have to do and to whom to report problems. Develop and maintain regular training programs for all employees.
<p>Keep These O&M Records</p>	<ul style="list-style-type: none"> <input type="checkbox"/> Keep results of your release detection system tests for at least 1 year. Your monitoring equipment may provide printouts that can be used as records. Unless you are recording actual release detection results at least every 30 days and maintaining records for at least 1 year, you are not doing leak detection right. <input type="checkbox"/> Keep the results of your most recent tightness test. <input type="checkbox"/> Keep all certification and performance claims for tank tightness test performed at your UST site for at least 5 years.

Daily Inventory Worksheet

Facility Name: _____

Your Name: _____

Date: _____

Tank Identification					
Type Of Fuel					
Tank Size In Gallons					
End Stick Inches					
Amount Pumped	↓	↓	↓	↓	↓
Totalizer Reading					
Totalizer Reading					
Totalizer Reading					
Totalizer Reading					
Totalizer Reading					
Totalizer Reading					
Totalizer Reading					
Totalizer Reading					
Today's Sum Of Totalizers					
Previous Day's Sum Of Totalizers					
Amount Pumped Today					
Delivery Record	↓	↓	↓	↓	↓
Inches of Fuel Before Delivery					
Gallons of Fuel Before Delivery (from tank chart)					
Inches of Fuel After Delivery					
Gallons of Fuel After Delivery (from tank chart)					
Gallons Delivered (Stick) [Gallons After - Gallons Before]					
Gross Gallons Delivered (Receipt)					

Monthly Inventory Record

Month/Year : ____ / ____

Tank Identification & Type Of Fuel: _____

Facility Name: _____

Date Of Water Check: _____ Level Of Water (Inches): _____

Date	Start Stick Inventory (Gallons)	Gallons Delivered	Gallons Pumped	Book Inventory (Gallons)	End Stick Inventory		Daily Over (+) Or Short (-) [End - Book]	Initials
					(Inches)	(Gallons)		
1	(+)	(-)	(=)					
2	(+)	(-)	(=)					
3	(+)	(-)	(=)					
4	(+)	(-)	(=)					
5	(+)	(-)	(=)					
6	(+)	(-)	(=)					
7	(+)	(-)	(=)					
8	(+)	(-)	(=)					
9	(+)	(-)	(=)					
7	(+)	(-)	(=)					
8	(+)	(-)	(=)					
9	(+)	(-)	(=)					
10	(+)	(-)	(=)					
11	(+)	(-)	(=)					
12	(+)	(-)	(=)					
13	(+)	(-)	(=)					
14	(+)	(-)	(=)					
15	(+)	(-)	(=)					
16	(+)	(-)	(=)					
17	(+)	(-)	(=)					
18	(+)	(-)	(=)					
19	(+)	(-)	(=)					
20	(+)	(-)	(=)					
21	(+)	(-)	(=)					
22	(+)	(-)	(=)					
23	(+)	(-)	(=)					
24	(+)	(-)	(=)					
25	(+)	(-)	(=)					
26	(+)	(-)	(=)					
27	(+)	(-)	(=)					
28	(+)	(-)	(=)					
29	(+)	(-)	(=)					
30	(+)	(-)	(=)					
31	(+)	(-)	(=)					

Total Gallons Pumped >

Total Gallons Over Or Short >

Leak Check:
Drop the last two digits
from the **Total Gallons**

Pumped number and enter here: _____

+ 130 =

Compare these numbers

_____ gallons

Is the total gallons over or short **larger** than leak check result? **Yes No** (circle one)

If your answer is Yes for 2 months in a row, **notify the regulatory agency** as soon as possible.

Keep This Piece Of Paper On File For At Least 1 Year

Manual Tank Gauging (for tanks 1,000 gallons or less only)	
Description Of Release Detection	<u>This method may be used only for tanks of 1,000 gallons or less capacity meeting certain requirements. These requirements (tank size, tank dimension, and test time) are found in the manual tank gauging record on the next page. Manual tank gauging involves taking your tank out of service for the testing period (at least 36 hours) each week, during which time the contents of the tank are measured twice at the beginning and twice at the end of the test period. The measurements are then compared to weekly and monthly standards to determine if the tank is tight.</u>
Have Certification For Your Release Detection Method	None required.
Perform These O&M Actions	<ul style="list-style-type: none"> <input type="checkbox"/> Once a week, record two inventory readings at the beginning of the test, allow the tank to sit undisturbed for the time specified in the Manual Tank Gauging Record on the next page, and record two inventory readings at the end of the test (use any form comparable to the one on the following page). <input type="checkbox"/> Reconcile the numbers weekly and record them on a Manual Tank Gauging Record (see the next page). <input type="checkbox"/> See Section 3 of this manual if your tank fails the weekly standard. <input type="checkbox"/> At the end of 4 weeks, reconcile your records for the monthly standard and record the result on a Manual Tank Gauging Record (see the next page). <input type="checkbox"/> See Section 3 of this manual if your tank fails the monthly standard. <input type="checkbox"/> Ensure that your measuring stick can measure to the nearest one-eighth inch and can measure the level of product over the full range of the tank's height. You should check your measuring stick periodically to make sure that you can read the markings and numbers and that the bottom of the stick is not worn. <input type="checkbox"/> Make sure employees who run, monitor, or maintain the release detection system know exactly what they have to do and to whom to report problems. Develop and maintain regular training programs for all employees.
Keep These O&M Records	<ul style="list-style-type: none"> <input type="checkbox"/> Keep your manual tank gauging records for at least 1 year. Unless you are recording actual release detection results weekly and at least every 30 days and maintaining records for at least 1 year, you are not doing leak detection right.

Manual Tank Gauging Record

Month _____ Year _____
 Tank Identification: _____
 Person Completing Form: _____
 Facility Name: _____

Circle your tank size, test duration, and weekly/monthly standards in the table below:

Tank Size	Minimum Duration Of Test	Weekly Standard (1 test)	Monthly Standard (4-test average)
up to 550 gallons	36 hours	10 gallons	5 gallons
551-1,000 gallons (when tank diameter is 64")	44 hours	9 gallons	4 gallons
551-1,000 gallons (when tank diameter is 48")	58 hours	12 gallons	6 gallons
551-1,000 gallons (also requires periodic tank tightness testing)	36 hours	13 gallons	7 gallons
1,001-2,000 gallons (also requires periodic tank tightness testing)	36 hours	26 gallons	13 gallons

Compare your weekly readings and the monthly average of the 4 weekly readings with the standards shown in the table on the left.

If the calculated change exceeds the weekly standard, the UST may be leaking. Also, the monthly average of the 4 weekly test results must be compared to the monthly standard in the same way.

If either the weekly or monthly standards have been exceeded, the UST may be leaking. As soon as possible, call your implementing agency to report the suspected leak and get further instructions.

Start Test (month, day, and time)	First Initial Stick Reading	Second Initial Stick Reading	Average Initial Reading	Initial Gallons (convert inches to gallons) [a]	End Test (month, day, and time)	First End Stick Reading	Second End Stick Reading	Average End Reading	End Gallons (convert inches to gallons) [b]	Change In Tank Volume In Gallons + or (-) [a-b]	Tank Passes Test (circle Yes or No)
Date: _____ Time: _____ AM/PM					Date: _____ Time: _____ AM/PM						Y N
Date: _____ Time: _____ AM/PM					Date: _____ Time: _____ AM/PM						Y N
Date: _____ Time: _____ AM/PM					Date: _____ Time: _____ AM/PM						Y N
Date: _____ Time: _____ AM/PM					Date: _____ Time: _____ AM/PM						Y N
<p>Keep This Piece Of Paper On File For At Least 1 Year</p>											Y N
<p>To see how close you are to the monthly standard, divide the sum of the 4 weekly readings by 4 and enter result here ></p>											Y N

Manual Tank Gauging And Tank Tightness Testing (for tanks 2,000 gallons or less only)

Description Of Release Detection	<p>This temporary method combines manual tank gauging with periodic tank tightness testing. <u>It may be used only for tanks of 2,000 gallons or less capacity.</u> Manual tank gauging involves taking your tank out of service for the testing period (at least 36 hours) each week, during which the contents of the tank are measured twice at the beginning and twice at the end of the test period. The measurements are then compared to weekly and monthly standards to determine if the tank is tight. This combined method also includes tightness testing, a sophisticated test performed by trained professionals.</p> <p><i>NOTE: This combination method can only be used temporarily for up to ten years after installing a new UST or for up to 10 years after your tank meets the corrosion protection requirements.</i></p>
Have Certification For Your Release Detection Method	<ul style="list-style-type: none"> <input type="checkbox"/> Make sure your tank tightness testing is certified for the types of tanks and stored contents on which the tightness test is used. Most tightness test methods are certified by a third party to verify that they meet specific performance requirements set by regulatory agencies. If you don't have certified performance claims, have the tightness tester provide them to you.
Perform These O&M Actions	<ul style="list-style-type: none"> <input type="checkbox"/> Once a week, record two inventory readings at the beginning of the test, allow the tank to sit undisturbed for the time specified in the Manual Tank Gauging Record on page 16, and record two inventory readings at the end of the test (use any form comparable to the one on page 16). <input type="checkbox"/> Reconcile the numbers weekly and record them on a Manual Tank Gauging Record (see page 16). <input type="checkbox"/> See Section 3 of this manual if your tank fails the weekly standard. <input type="checkbox"/> At the end of 4 weeks, reconcile your records for the monthly standard and record the result on a Manual Tank Gauging Record (see page 16). <input type="checkbox"/> See Section 3 of this manual if your tank fails the monthly standard. <input type="checkbox"/> Conduct a tank tightness test at least every 5 years. This testing needs to be conducted by a professional trained in performing tank tightness testing. <input type="checkbox"/> See Section 3 of this manual if your tank fails the tightness test. <input type="checkbox"/> Ensure that your measuring stick can measure to the nearest one-eighth inch and can measure the level of product over the full range of the tank's height. You should check your measuring stick periodically to make sure that you can read the markings and numbers and that the bottom of the stick is not worn. <input type="checkbox"/> Make sure employees who run, monitor, or maintain the release detection system know exactly what they have to do and to whom to report problems. Develop and maintain regular training programs for all employees.
Keep These O&M Records	<ul style="list-style-type: none"> <input type="checkbox"/> Keep your manual tank gauging records for at least 1 year. Unless you are recording actual release detection results at least weekly and every 30 days and maintaining records for at least 1 year, you are not doing leak detection right. <input type="checkbox"/> Keep the results of your most recent tightness test. <input type="checkbox"/> Keep all certification and performance claims for tank tightness test performed at your UST site for at least 5 years.

Automatic Line Leak Detection (for pressurized piping only)	
Description Of Release Detection	Automatic line leak detectors (LLDs) are designed to detect a catastrophic release from pressurized piping. Automatic LLDs must be designed to detect a leak at least as small as 3 gallons per hour at a line pressure of 10 psi within 1 hour. When a leak is detected, automatic LLDs must shut off the product flow, restrict the product flow, or trigger an audible or visual alarm. NOTE: Mechanical automatic LLDs need to be installed and operated as close as possible to the tank (LLDs are designed to detect a leak, restrict flow, etc. only between the detector and the dispenser).
Have Certification For Your Release Detection Method	<ul style="list-style-type: none"> <input type="checkbox"/> Make sure your release detection equipment is certified for the types of piping and stored contents on which the release detection system is used. Most manufacturers have their leak detection devices tested and certified by a third party to verify that their equipment meets specific performance requirements set by regulatory agencies. If you don't have certified performance claims, have the manufacturer provide them to you.
Perform These O&M Actions	<ul style="list-style-type: none"> <input type="checkbox"/> Frequently test your automatic LLDs according to the manufacturer's instructions to make sure it is working properly. Don't assume that your release detection system is working and never needs checking. Some monitoring systems have a test or self-diagnosis mode. <input type="checkbox"/> Periodically have a qualified UST contractor, such as the vendor who installed your release detection system, service all the system components according to the manufacturers' service instructions. Components can wear out and must be checked periodically. Many vendors recommend or require this maintenance activity at least annually. <input type="checkbox"/> See Section 3 of this manual if your LLD detects a leak. <input type="checkbox"/> Make sure employees who run, monitor, or maintain the release detection system know exactly what they have to do and to whom to report problems. Develop and maintain regular training programs for all employees.
Keep These O&M Records	<ul style="list-style-type: none"> <input type="checkbox"/> For at least a year, keep the annual test that demonstrates that the LLD is functioning properly. <input type="checkbox"/> If used for monthly monitoring, keep results of your release detection system tests for at least 1 year. Your monitoring equipment system may provide printouts that can be used as records. Unless you are recording actual release detection results at least every 30 days and maintaining records for at least 1 year, you are not doing leak detection right. <input type="checkbox"/> Keep all records of calibration, maintenance, and repair of your release detection equipment for at least 1 year. <input type="checkbox"/> Keep all performance claims supplied by the installer, vendor, or manufacturer for at least 5 years. These records include the certification of your leak detection equipment described above.

Line Tightness Testing (for piping only)	
Description Of Release Detection	This method uses a periodic line tightness test to determine if your piping is leaking. Tightness testing can be performed by either a trained professional or by using a permanently installed electronic system (sometimes connected to an automatic tank gauging system).
Have Certification For Your Release Detection Method	<ul style="list-style-type: none"> <input type="checkbox"/> Make sure your line tightness testing or permanently installed electronic system is certified for the types of piping and stored contents on which the release detection system is used. Most tightness test methods and release detection equipment have been tested and certified by a third party to verify that the equipment or services meet specific performance requirements set by regulatory agencies. If you don't have certified performance claims, have the tightness tester or equipment manufacturer provide them to you.
Perform These O&M Actions	<ul style="list-style-type: none"> <input type="checkbox"/> If line tightness testing is used for pressurized piping, the test must be conducted at least annually. <input type="checkbox"/> If line tightness testing is used for suction piping, the test must be conducted at least every three years. Safe suction piping as described at the bottom of page 3 may not need release detection testing. <input type="checkbox"/> This tightness testing must be conducted by a professional trained in performing line tightness testing or by using a permanently installed electronic system. <input type="checkbox"/> See Section 3 of this manual if your piping fails the tightness test or if the electronic system indicates a leak. <input type="checkbox"/> Periodically have a qualified UST contractor, such as the vendor who installed your release detection system, service all the system components according to the manufacturers' service instructions. Components can wear out and must be checked periodically. Many vendors recommend or require this maintenance activity at least annually. <input type="checkbox"/> Make sure employees who run, monitor, or maintain the release detection system know exactly what they have to do and to whom to report problems. Develop and maintain regular training programs for all employees.
Keep These O&M Records	<ul style="list-style-type: none"> <input type="checkbox"/> Keep results of your release detection system tests for at least 1 year. Your monitoring equipment may provide printouts that can be used as records. Unless you are recording actual release detection results at least every 30 days and maintaining records for at least 1 year, you are not doing leak detection right. <input type="checkbox"/> If you use a permanently installed electronic system, keep all records of calibration, maintenance, and repair of your equipment for at least 1 year. <input type="checkbox"/> Keep all performance claims supplied by the installer, vendor, or manufacturer for at least 5 years. These records include the certification of your leak detection equipment described above.

30-Day Release Detection Monitoring Record

(May be used for monitoring wells, interstitial monitoring, and automatic tank gauging)

Release Detection Method: _____

Facility Name: _____

Date	Your Name	UST System (Tank & Piping)			
		(Enter N for No Release Detected or Y for a Suspected Or Confirmed Release)			
		UST #	UST #	UST #	UST #

Keep This Piece Of Paper And Any Associated Printouts On File For At Least 1 Year From The Date Of The Last Entry

Section 3 — Suspected Or Confirmed Releases

You need to be fully prepared to respond to releases **before** they may occur. You need to know what to do when release detection methods indicate a suspected or confirmed release. Be ready to take the following steps, as appropriate.

Stop The Release

- Take immediate action to prevent the release of more product.
- Turn off the power to the dispenser and bag the nozzle.
- Make sure you know where your emergency shutoff switch is located.
- Empty the tank, if necessary, without further contaminating the site. You may need the assistance of your supplier or distributor.

Contain The Release

Contain, absorb, and clean up any surface spills or overfills. You should keep enough absorbent material at your facility to contain a spill or overfill of petroleum products until emergency response personnel can respond to the incident. The suggested supplies include, but are not limited to, the following:

- Containment devices, such as containment booms, dikes, and pillows.
- Absorbent material, such as kitty litter, chopped corn cob, sand, and sawdust. (Be sure you properly dispose of used absorbent materials.)
- Mats or other material capable of keeping spill or overfill out of nearby storm drains.
- Spark-free flash light.
- Spark-free shovel.
- Buckets.
- Reels of caution tape, traffic cones, and warning signs.
- Personal protective gear.

Also, identify any fire, explosion, or vapor hazards and take action to neutralize these hazards.

Call For Help

Contact your local fire or emergency response authority. Make sure you have these crucial telephone numbers prominently posted where you and your employees can easily see them. See the next page for a form you can copy and post.

Report To Authorities

If you observe any of the following, contact your state's underground storage tank regulatory authority to report a suspected or confirmed release as soon as possible (within 24 hours):

- Any spill or overflow of petroleum that exceeds 25 gallons or that causes a sheen on nearby surface water. (Spills and overfills under 25 gallons that are contained and immediately cleaned up do not have to be reported. If they can't be quickly cleaned up they must be reported to your regulatory agency.)
- Any released regulated substances at the UST site or in the surrounding area — such as the presence of liquid petroleum; soil contamination; surface water or groundwater contamination; or petroleum vapors in sewer, basement, or utility lines.
- Any unusual operating conditions you observe — such as erratic behavior of the dispenser, a sudden loss of product, or an unexplained presence of water in the tank. However, you are not required to report if:
 - The system equipment is found to be defective, but not leaking, and is immediately repaired or replaced.
- Results from your release detection system indicate a suspected release. However, you are not required to report if:
 - The monitoring device is found to be defective and is immediately repaired, recalibrated, or replaced and further monitoring does not confirm the initial suspected release, or
 - In the case of inventory control, a second month of data does not confirm the initial result.

The next page contains a blank list for names and phone numbers of important contacts. Fill out this information for your facility so that you will know who to call in case of an emergency. Remove this page from the manual, copy it, fill it out, and post it in a prominent place at your facility.

Copy the next page and update it often. Make sure everyone at your UST facility is familiar with this list of contacts.

Release Response Important Contact Information

	Contact Name	Phone #
State UST Agency:	_____	_____
Local UST Agency:	_____	_____
Fire Department:	_____	_____
Ambulance:	_____	_____
Police Department:	_____	_____
Repair Contractor:	_____	_____
Other Contacts:	_____	_____
	_____	_____
	_____	_____
	_____	_____

✓ Release Response Checklist

- ❑ **Stop the release:** Take immediate action to prevent the release of more product. Turn off the power to the dispenser and bag the nozzle. Make sure you know where your emergency shutoff switch is located. Empty the tank, if necessary, without further contaminating the site.
- ❑ **Contain the release:** Contain, absorb, and clean up any surface releases. Identify any fire, explosion, or vapor hazards and take action to neutralize these hazards.
- ❑ **Call for help and to report suspected or confirmed releases:** Contact your local fire or emergency response authority. Contact your state's underground storage tank regulatory authority within 24 hours.

Section 4 — Spill And Overfill Protection

The purpose of spill and overfill protection equipment is to eliminate the potential for a release during fuel deliveries. The equipment must be in working order and used properly to provide adequate protection from spills and overfills.

Even the best spill and overfill protection equipment can become faulty over time if not properly operated and maintained.

Only one gallon of fuel leaking each week from a poorly maintained spill bucket can result in up to 195 tons of contaminated soil in a year.

Improper maintenance of the spill bucket at the UST site pictured below contributed to significant contamination of soil and groundwater.

The following pages in this section focus on how you can routinely make sure your spill and overfill equipment is operating effectively.

What's The Difference?

Spill Protection:

A spill bucket is installed at the fill pipe to contain the drips and spills of fuel that can occur when the delivery hose is uncoupled from the fill pipe after delivery.

Overfill Protection:

Equipment is installed on the UST that is designed to stop product flow, reduce product flow, or alert the delivery person during delivery **before** the tank becomes full and begins releasing petroleum into the environment.



What Are The Basics Of Spill Protection?

Your USTs must have catchment basins — also called spill buckets — installed at the fill pipe to contain spills that may occur as a result of fuel deliveries.

- The spill bucket is designed to temporarily contain product spills that might occur during fuel delivery. To contain a spill, the spill bucket must be liquid tight.
- **The spill bucket is not designed to contain fuel for long periods of time.** After each delivery, empty and dispose of contents properly.
- Spill buckets need to be large enough to contain any fuel that may spill when the delivery hose is uncoupled from the fill pipe. Spill buckets typically range in size from 5 gallons to 25 gallons.
- If you use a checklist for correct delivery practices (see page 33), spills should be eliminated or reduced to very small volumes that your spill bucket can easily handle.

If your UST **never** receives deliveries of more than 25 gallons at a time, the UST does not need to meet the spill protection requirements. Many used oil tanks fall into this category. Even though these USTs are not required to have spill protection, you should consider using spill protection as part of good UST system management.

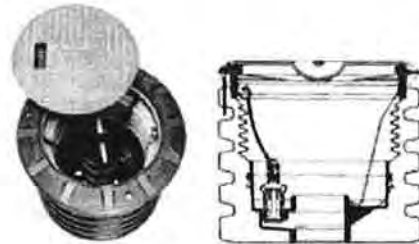

Examples Of Spill Buckets

How Do You Maintain Your Spill Bucket?

The checklist below provides information on properly maintaining your spill bucket.

✓ Spill Bucket O&M Checklist

- Keep your spill bucket empty of liquids.**
Some spill buckets are equipped with a valve that allows you to drain accumulated fuel into your UST. Others may be equipped with a manual pump so fuel can be put into your UST by pumping it through the fill pipe. However, keep in mind that when you pump out or drain your spill bucket into your UST, any water and debris may also enter the UST. If a basin is not equipped with drain valve or pump, then any accumulated fuel or water must be removed manually and disposed of properly.
- Periodically check your spill bucket to remove any debris.**
Debris could include soil, stones, or trash.
- Periodically check to see if your spill bucket is still liquid tight.**
Have a qualified UST contractor inspect your spill bucket for signs of wear, cracks, or holes. Based on this inspection, the contractor may suggest a test to determine if the spill bucket is tight or needs repair or replacement.

What Are The Basics Of Overfill Protection?

Your USTs must have overfill protection installed to help prevent the overfilling of tanks.

Three types of overfill protection devices are commonly used:

- Automatic shutoff devices
- Overfill alarms
- Ball float valves

Each of these forms of overfill protection is discussed in detail on the following pages.

If your UST **never** receives deliveries of more than 25 gallons at a time, the UST does not need to meet the overfill protection requirements. Many used oil tanks fall into this category. Even though these USTs are not required to have overfill protection, you should consider using overfill protection as part of good UST system management.

How Can You Help The Delivery Person Avoid Overfills?

To protect your business, you must make every effort to help the delivery person avoid overfilling your UST.

Use A Checklist On Correct Filling Practices

If correct filling practices are used, you will not exceed the UST's capacity — see page 33 for a checklist on correct filling procedures. Overfills are caused when the delivery person makes a mistake, such as ignoring an overfill alarm.

Use Signs, Alert Your Delivery Person

The delivery person should know what type of overfill device is present on each tank at your facility and what action will occur if the overfill device is triggered — such as a visual and/or audible alarm or that the product flow into the tank will stop or slow significantly.

Educate and alert your delivery person by placing a clear sign near your fill pipes, in plain view of the delivery person. An example of such a sign follows on the next page.

Delivery Person — Avoid Overfills

- An **overflow alarm** is used for overflow protection at this facility.
- Do not tamper with this alarm in any attempt to defeat its purpose.
- When the tank is 90% full, the overflow alarm whistles and a red light flashes.
- **If you hear the alarm whistle or see the red light flashing,**

Stop The Delivery Immediately!

Make Sure You Order The Right Amount Of Product

Also, you need to **make sure you've ordered the right amount of product for delivery**. Order only the quantity of fuel that will fit into 90% of the tank. For example, if you have a 10,000 gallon tank with 2,000 gallons already in the tank, you would order at the most a 7,000 gallon delivery (90% of 10,000 is 9,000 gallons; subtracting the 2,000 gallons already in the tank leaves a maximum delivery of 7,000 gallons). Use the checklist formula on page 33. Do your homework right and you reduce the chance of overfills.

What Should You Do To Operate And Maintain Your Automatic Shutoff Device?

The automatic shutoff device is a mechanical device installed in line with the drop tube within the fill pipe riser. It slows down and then stops the delivery when the product has reached a certain level in the tank. It should be positioned so that the float arm is not obstructed and can move through its full range of motion.

When installed and maintained properly, the shutoff valve will shut off the flow of fuel to the UST at 95% of the tank's capacity or before the fittings at the top of the tank are exposed to fuel.

You should not use an automatic shutoff device for overfill protection if your UST receives pressurized deliveries.

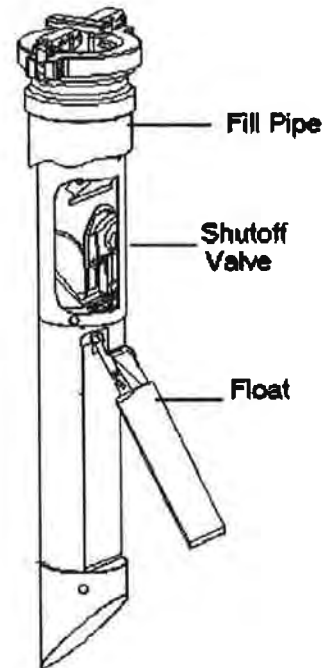

✓ Basic O&M Checklist For Automatic Shutoff Devices

- ❑ A qualified UST contractor periodically checks to make sure that the automatic shutoff device is functioning properly and that the device will shut off fuel flowing into the tank at 95% of the tank capacity or before the fittings at the top of the tank are exposed to fuel:
 - Make sure the float operates properly.
 - Make sure there are no obstructions in the fill pipe that would keep the floating mechanism from working.
- ❑ You have posted signs that the delivery person can easily see and that alert the delivery person to the overfill warning devices and alarms in use at your facility.

What Should You Do To Operate And Maintain Your Electronic Overfill Alarm?

This type of overfill device activates an audible and/or visual warning to delivery personnel when the tank is either 90% full or is within one minute of being overfilled. **The alarm *must* be located so it can be seen and/or heard from the UST delivery location.** Once the electronic overfill alarm sounds, the delivery person has approximately one minute to stop the flow of fuel to the tank.

Electronic overfill alarm devices have no mechanism to shut off or restrict flow. Therefore, the fuel remaining in the delivery hose after the delivery has been stopped will flow into the tank as long as the tank is not yet full.



✓ Basic O&M Checklist For Overfill Alarms

- A qualified UST contractor periodically checks your electronic overfill alarm to make sure that it is functioning properly and that the alarm activates when the fuel reaches 90% of the tank capacity or is within one minute of being overfilled:
 - Ensure that the alarm can be heard and/or seen from where the tank is fueled.
 - Make sure that the electronic device and probe are operating properly.
- You have posted signs that the delivery person can easily see and that alert the delivery person to the overfill warning devices and alarms in use at your facility.

What Should You Do To Operate And Maintain Your Ball Float Valve?

The ball float valve — also called a float vent valve — is installed at the vent pipe in the tank and restricts vapor flow in an UST as the tank gets close to being full. The ball float valve should be set at a depth which will restrict vapor flow out of the vent line during delivery at 90% of the UST's capacity or 30 minutes prior to overfilling.

As the tank fills, the ball in the valve rises, restricting the flow of vapors out of the UST during delivery. The flow rate of the delivery will decrease noticeably and should alert the delivery person to stop the delivery.

For ball float valves to work properly, the top of the tank must be air tight so that vapors cannot escape from the tank. Everything from fittings to drain mechanisms on spill buckets must be tight and be able to hold the pressure created when the ball float valve engages.



You should not use a ball float valve for overfill protection if any of the following apply:

- Your UST receives pressurized deliveries.
- Your UST system has suction piping.
- Your UST system has single point (coaxial) stage 1 vapor recovery.

✓ Basic O&M Checklist For Ball Float Valves

- A qualified UST contractor periodically checks to make sure that the ball float valve is functioning properly and that it will restrict fuel flowing into the tank at 90% of the tank capacity or 30 minutes prior to overfilling:
 - Ensure that the air hole is not plugged.
 - Make sure the ball cage is still intact.
 - Ensure the ball still moves freely in the cage.
 - Make sure the ball still seals tightly on the pipe.
- You have posted signs that the delivery person can easily see and that alert the delivery person to the overfill warning devices and alarms in use at your facility.

✓ Spill And Overfill O&M Checklist

Spill Bucket	<ul style="list-style-type: none"> ❑ Keep your spill bucket empty of liquids. Some spill buckets are equipped with a drainage valve which allows you to drain accumulated fuel into your UST. Others can be equipped with a manual pump so fuel can be put into your UST by pumping it through the fill pipe. However, keep in mind that when you pump out or drain your spill bucket into your UST, any water and debris may also enter the UST. If a spill bucket is not equipped with a drain valve or pump, then any accumulated fuel or water must be removed manually and disposed of properly. ❑ Periodically check your spill bucket to remove any debris. Debris could include soil, stones, or trash. ❑ Periodically check to see if your spill bucket is still liquid tight. Have a qualified UST contractor inspect your spill bucket for signs of wear, cracks, or holes. Based on this inspection, the contractor may suggest a test to determine if the spill bucket is tight or needs repair or replacement.
Automatic Shutoff Devices	<ul style="list-style-type: none"> ❑ A qualified UST contractor periodically checks to make sure that the automatic shutoff device is functioning properly and that the device will shut off fuel flowing into the tank at 95% of the tank capacity or before the fittings at the top of the tank are exposed to fuel: <ul style="list-style-type: none"> • Make sure the float operates properly. • Make sure that there are no obstructions in the fill pipe that would keep the floating mechanism from working. ❑ You have posted signs that the delivery person can easily see and that alert the delivery person to the overfill warning devices and alarms in use at your facility.
Overfill Alarms	<ul style="list-style-type: none"> ❑ A qualified UST contractor periodically checks your electronic overfill alarm to make sure that it is functioning properly and that the alarm activates when the fuel reaches 90% of the tank capacity or is within one minute of being overfilled: <ul style="list-style-type: none"> • Ensure that the alarm can be heard and/or seen from where the tank is fueled. • Make sure that the electronic device and probe are operating properly. ❑ You have posted signs that the delivery person can easily see and that alert the delivery person to the overfill warning devices and alarms in use at your facility.
Ball Float Valves	<ul style="list-style-type: none"> ❑ A qualified UST contractor periodically checks to make sure that the ball float valve is functioning properly and that it will restrict fuel flowing into the tank at 90% of the tank capacity or 30 minutes prior to overfilling: <ul style="list-style-type: none"> • Ensure that the air hole is not plugged. • Make sure the ball cage is still intact. • Ensure the ball still moves freely in the cage. • Make sure the ball still seals tightly on the pipe. ❑ You have posted signs that the delivery person can easily see and that alert the delivery person to the overfill warning devices and alarms in use at your facility.

What Are Your Responsibilities For Correct Filling Practices?

As an owner or operator you are responsible for ensuring that releases due to spilling or overfilling do not occur during fuel delivery.

As part of this responsibility, you must:

- Ensure the amount of product to be delivered will fit into the available empty space in the tank; and
- Ensure the transfer operation is monitored constantly to prevent overfilling and spilling.

One way help ensure the above requirements are met is to follow the checklist on the next page. The checklist describes activities to perform before, during, and after a fuel delivery.



✓ Correct Filling Checklist

<p>What To Do Before Your USTs Are Filled</p>	<ul style="list-style-type: none"> <input type="checkbox"/> Post clear signs that alert delivery persons to the overfill devices and alarms in use at your facility. <input type="checkbox"/> Make and record accurate readings for product and water in the tank before fuel delivery. <input type="checkbox"/> Order only the quantity of fuel that will fit into 90% of the tank. <p style="text-align: center;">Remember, the formula for determining the maximum amount of gasoline to order is:</p> <p style="text-align: center;">(Tank capacity in gallons X 90%) — Product currently in tank = Maximum amount of fuel to order</p> <p style="text-align: center;">Example: (10,000 gal X 0.9) — 2,000 gal = 7,000 gal maximum amount to order</p> <ul style="list-style-type: none"> <input type="checkbox"/> Ensure fuel delivery personnel know the type of overfill device present at the tank and what actions to perform if it activates. For example, use sample sign on page 27 of this chapter. <input type="checkbox"/> Review and understand the spill response procedures. <input type="checkbox"/> Verify that your spill bucket is empty, clean, and will contain spills.
<p>What To Do While Your USTs Are Being Filled</p>	<ul style="list-style-type: none"> <input type="checkbox"/> Keep fill ports locked until the fuel delivery person requests access. <input type="checkbox"/> Have an accurate tank capacity chart available for the fuel delivery person. <input type="checkbox"/> The fuel delivery person makes all hook-ups. The person responsible for monitoring the delivery should remain attentive and observe the entire fuel delivery, be prepared to stop the flow of fuel from the truck to the UST at any time, and respond to any unusual condition, leak, or spill which may occur during delivery. <input type="checkbox"/> Have response supplies readily available for use in case a spill or overfill occurs (see Section 3). <input type="checkbox"/> Provide safety barriers around the fueling zone. <input type="checkbox"/> Make sure there is adequate lighting around the fueling zone.
<p>What To Do After Your USTs Are Filled</p>	<ul style="list-style-type: none"> <input type="checkbox"/> Following complete delivery, the fuel delivery person is responsible for disconnecting all hook-ups. <input type="checkbox"/> Return spill response kit and safety barriers to proper storage locations. <input type="checkbox"/> Make and record accurate readings for product and water in the tank after fuel delivery. <input type="checkbox"/> Verify the amount of fuel received. <input type="checkbox"/> Make sure fill ports are properly secured. <input type="checkbox"/> Ensure the spill bucket is free of product and clean up any small spills.

Section 5 — Corrosion Protection

To prevent leaks, all parts of your UST system that are underground and routinely contain product need to be protected from corrosion. The UST system includes the tank, piping, and ancillary equipment, such as flexible connectors, fittings, and pumps. Unprotected metal UST components can deteriorate and leak when underground electrical currents act upon them.

One way to protect UST components from corrosion is to **make them with nonmetallic, noncorrodible materials**, such as USTs made of (or clad or jacketed with) fiberglass reinforced plastic (FRP) or other noncorrodible materials — as illustrated by the FRP tank on the right. Noncorrodible USTs like these do not require O&M for corrosion protection.



UST components made from metal, however, that routinely contain product and are in direct contact with the ground need corrosion protection provided by cathodic protection or (in some cases) lining the interior of the tank, as described below. These options require O&M.

Note: Metal tanks or piping installed after December 22, 1988 must have a dielectric coating (a coating that does not conduct electricity) in addition to the cathodic protection described below.

Cathodic Protection Using Sacrificial Anode Systems

Sacrificial anodes are buried and attached to UST components for corrosion protection — as illustrated on the right by an anode attached to a tank. Anodes are pieces of metal that are more electrically active than steel, and thus they suffer the destructive effects of corrosion rather than the steel they are attached to.



Cathodic Protection Using Impressed Current Systems

An impressed current system — as shown on the right — uses a rectifier to provide direct current through anodes to the tank or piping to achieve corrosion protection. The steel is protected because the current going to the steel overcomes the corrosion-causing current flowing away from it. **The cathodic protection rectifier must always be on and operating to protect your UST system from corrosion.**

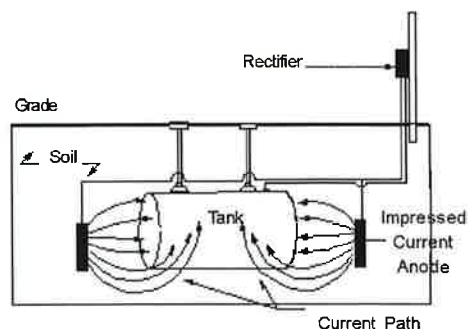

Corrosion Protection Using Internal Lining Of The Tank

This corrosion protection option applies only to tanks installed before December 22, 1988. These older tanks can be internally lined by trained professionals to meet the corrosion protection requirements — as shown on the right, in which a professional follows industry codes to safely and effectively line a tank's interior.



It may help you to see your corrosion protection options displayed in the following table.

Corrosion Protection Choices	
Option	Description
Noncorrodible Material	The tank or piping is constructed of noncorrodible material.
Steel Tank Clad Or Jacketed With A Noncorrodible Material	Examples of cladding or jacket material include fiberglass and urethane. Does not apply to piping.
Coated And Cathodically Protected Steel Tanks Or Piping	Steel tank and piping is well-coated with a dielectric material and cathodically protected.
Cathodically Protected Noncoated Steel Tanks Or Piping	<i>This option is only for steel tanks and piping installed before December 22, 1988. Cathodic protection is usually provided by an impressed current system.</i>
Internal Lining Of Tanks	<i>This option is only for steel tanks installed before December 22, 1988. A lining is applied to the inside of the tank. Does not apply to piping.</i>
Combination Of Cathodically Protected Steel And Internal Lining Of Tanks	<i>This option is only for steel tanks installed before December 22, 1988. Cathodic protection is usually provided by an impressed current system. Does not apply to piping.</i>
Other Methods Used To Achieve Corrosion Protection	If you have tanks or piping that do not meet any of the descriptions above, check with your state UST agency to see if your UST system meets the requirements for corrosion protection. You also will need to ask about the operation, maintenance, and record keeping requirements applicable to this type of UST system.

Note: In addition to tanks and piping, all other metal components in direct contact with the ground that routinely hold product — such as flexible connectors, swing joints, fittings, and pumps — must also be cathodically protected.

Use the O&M checklist on the next page. Following the checklist look for record keeping forms and discussions of special corrosion protection situations.

✓ Basic O&M Checklist For Corrosion Protection

<p>Sacrificial Anode Cathodic Protection Systems</p>	<p>You need to have a periodic test conducted by a qualified corrosion tester to make sure your cathodic protection system is adequately protecting your UST system. This test needs to be conducted:</p> <ul style="list-style-type: none"> <input type="checkbox"/> Within 6 months of installation. <input type="checkbox"/> At least every 3 years after the previous test. <input type="checkbox"/> Within 6 months after any repairs to your UST system. <ul style="list-style-type: none"> • Make sure the professional tester is qualified to perform the test and follows a standard code of practice to determine that test criteria are adequate. • If any test indicates your tanks are not adequately protected, you need to have a corrosion expert examine and fix your system. • Testing more frequently can catch problems before they become big problems. <input type="checkbox"/> You need to keep the results of at least the last two tests on file. See the next page for a cathodic protection test record keeping form.
<p>Impressed Current Cathodic Protection Systems</p>	<p>You need to have a periodic test conducted by a qualified corrosion tester to make sure your cathodic protection system is adequately protecting your UST system. This test needs to be conducted:</p> <ul style="list-style-type: none"> <input type="checkbox"/> Within 6 months of installation. <input type="checkbox"/> At least every 3 years after the previous test. <input type="checkbox"/> Within 6 months after any repairs to your UST system. <ul style="list-style-type: none"> • Make sure the professional tester is qualified to perform the test and follows a standard code of practice to determine that test criteria are adequate. • If any test indicates your tanks are not adequately protected, you need to have a corrosion expert examine and fix your system. • Testing more frequently can catch problems before they become big problems. <input type="checkbox"/> You need to keep the results of at least the last two tests on file. See next page for a cathodic protection test record keeping form. <input type="checkbox"/> You need to inspect your rectifier at least every 60 days to make sure that it is operating within normal limits. <ul style="list-style-type: none"> • This inspection involves reading and recording the voltage and amperage readouts on the rectifier. You or your employees can perform this periodic inspection. • Make sure your cathodic protection professional provides you with the rectifier's acceptable operating levels so you can compare the readings you take with an acceptable operating level. If your readings are not within acceptable levels, you must contact a cathodic protection professional to address the problem. <input type="checkbox"/> You need to keep records of at least the last 3 rectifier readings. See page 39 for a 60-Day Inspection Results record keeping form. <input type="checkbox"/> You should have a trained professional periodically service your impressed current system. <input type="checkbox"/> Never turn off your rectifier!
<p>Internally Lined Tanks</p>	<ul style="list-style-type: none"> <input type="checkbox"/> Within 10 years after lining and at least every 5 years thereafter, the lined tank must be inspected by a trained professional and found to be structurally sound with the lining still performing according to original design specifications. Make sure the professional performing the inspection follows a standard code of practice. <input type="checkbox"/> Keep records of the inspection (as specified in industry standards for lining inspections).

Record For Periodic Testing Of Cathodic Protection Systems

(for use by a qualified cathodic protection tester)

Test Date:___/___/___ Facility Name/ID:_____

Note: Provide site sketch as directed on the back of this page.

Cathodic Protection (CP) Tester Information:

Name: _____ Phone Number: _____

Address: _____

Testing must be conducted by a qualified CP tester. Indicate your qualifications as a CP tester:

Identify which of the following testing situations applies:

- Test required within 6 months of installation of CP system (installation date was ___/___/___)
- Test required at least every 3 years after installation test noted above
- Test required within 6 months of any repair activity – note repair activity and date below:

Indicate which industry standard you used to determine that the cathodic protection test criteria are adequate: _____

Cathodic Protection Test Method Used (check one)	
	100 mV Cathodic Polarization Test
	-850 mV Test (Circle 1 or 2 below)
	1) Polarized Potential (instant off) 2) Potential with CP Applied, IR Drop Considered
	Note: All readings taken must meet the -850 mV criteria to pass
	Other Accepted Method (please describe):

Is the cathodic protection system working properly? Yes No
(circle one)

If answer is no, go to the directions at the bottom on the back of this page.

My signature below affirms that I have sufficient education and experience to be a cathodic protection tester; I am competent to perform the tests indicated above; and that the results on this form are a complete and truthful record of all testing at this location on the date shown.

CP Tester Signature: _____ Date: _____

Keep This Paper On File For At Least Six Years

Site Sketch: Provide a rough sketch of the tanks and piping, the location of each CP test, and each voltage value obtained (use space below or attach separate drawing). Voltage readings through concrete or asphalt do not provide accurate readings and are not acceptable. Perform sufficient testing to evaluate the entire UST system.

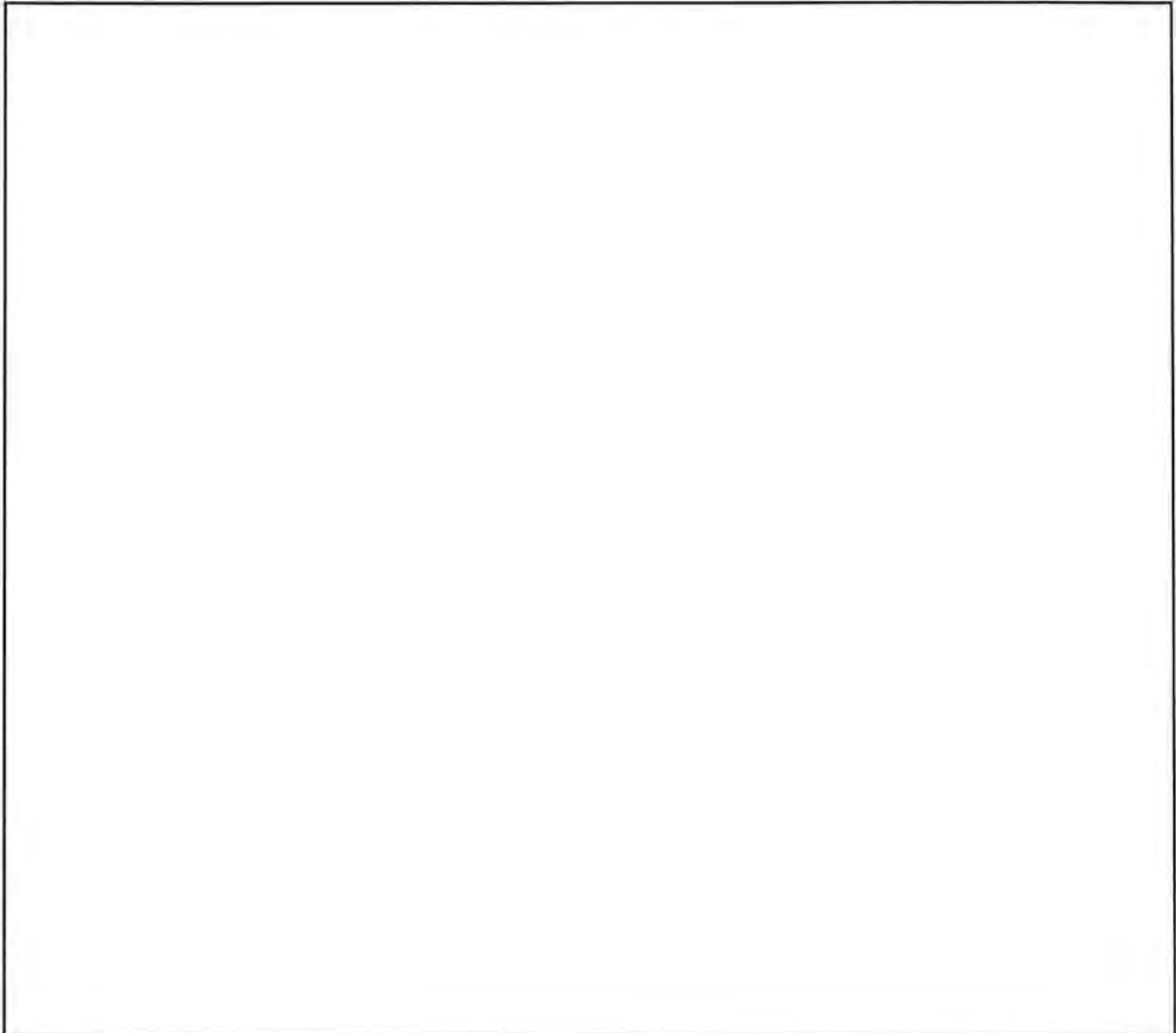

If CP system fails test, you must have a corrosion expert fix the system.

If the answer was no, indicating that your CP system is not working, you must have a **corrosion expert** investigate and fix the problem. A corrosion expert has additional training, skills, and certification beyond the corrosion tester who filled out the bulk of this form. A corrosion expert must be:

- Accredited/certified by NACE International (The Corrosion Society) as a corrosion specialist or cathodic protection specialist, or
- Be a registered professional engineer with certification or licensing in corrosion control.

As long as you have the UST, be sure you keep a record that clearly documents what the corrosion expert did to fix your CP system.

Keep This Paper On File For At Least Six Years

60-Day Inspection Results For Impressed Current Cathodic Protection Systems

Facility Name: _____

Amp Range Recommended: _____

Voltage Range Recommended: _____

Date	Your Name	Voltage Reading	Amp Reading	Is Your System Running Properly? (Yes/No)

- If the rectifier voltage and/or amperage output(s) are outside the recommended operating levels, contact a cathodic protection expert to address the problem.
- Never turn off your rectifier.
- Keep this record for at least 6 months after the date of the last reading.

Some Special Corrosion Protection Situations

What If You Have An STI-P3 Tank With A PP4 Test Station?

If you have a PP4 test station installed with an STI-P3 tank, you may perform the periodic testing of your cathodic protection system by using the meter provided to you with the PP4 test station.

- Don't forget to record the result of the reading and keep at least the last two results.
- If your test readings do not pass, you must take action to correct the problem. Call your installer and ask that the corrosion expert who designed the system examine it and correct the problem.

What If You Combine Internal Lining And Cathodic Protection?

If you chose the combination of internal lining and cathodic protection for meeting corrosion protection requirements on your UST, you may not have to meet the periodic inspection requirement for the lined tank. However, you must always meet the requirements for checking and testing your cathodic protection system as described in the basic O&M checklist for corrosion protection on page 36. The 10-year and subsequent 5-year inspections of the lined tank are not required if the integrity of the tank was ensured when cathodic protection was added. You should be able to show an inspector documentation of the passed integrity assessment.

Example 1:

If you have cathodic protection and internal lining applied to your tank at the same time, periodic inspections of the lined tank **are not** required because an integrity assessment of the tank is required prior to adding the cathodic protection and internal lining.

Example 2:

If you had cathodic protection added to a tank in 1997 that was internally lined in 1994 and the contractor did not perform an integrity assessment of the tank at the time cathodic protection was added (or you cannot show an inspector documentation of the passed integrity assessment), then periodic inspections of the lined tank **are** required because you cannot prove that the tank was structurally sound and free of corrosion holes when the cathodic protection was added. The lined tank needs to be periodically inspected because the lining may be the only barrier between your gasoline and the surrounding environment.

What If You Have A Double Walled Steel UST With Interstitial Monitoring And Cathodic Protection?

If you have a cathodically protected double walled steel tank and you use interstitial monitoring capable of detecting a breach in both the inner and outer wall or ingress of product and water as your method of leak detection, then you should monitor your cathodic protection system within six months of installation and following any activity that could affect the CP system.

If you are using impressed current cathodic protection, you still need to perform the 60-day checks of your rectifier to make sure it is operating within normal limits.

- Testing the cathodic protection system more frequently may help catch problems quicker.
- If your test readings do not pass, you must take action to correct the problem. Call your installer and ask that the corrosion expert who designed the system examine it and correct the problem.
- Don't forget to keep at least the last two results of your cathodic protection testing.

Do All UST Sites Need Corrosion Protection?

A corrosion expert may be able to determine the soil at an UST site is not conducive to corrosion and will not cause the tank or piping to have a release during its operating life. If so, you must keep a record of that corrosion expert's analysis for the life of the tank or piping to demonstrate why your UST has no corrosion protection.

Section 6 — Frequent Walk-Through Inspections

You should conduct basic walk-through inspections of your facility **at least monthly** to make sure your essential equipment is working properly and you have release response supplies on hand.

These inspections would not be as thorough as following the O&M checklists presented earlier in this booklet, but they can provide a quick overview you can do more often than the longer checklists. You might think of this level of inspection as similar to automobile dashboard indicators that provide us with status warnings like low battery.

When you perform your walk-through inspection you should quickly check at least the following:

- **Release Detection System:** Is your release detection equipment working properly? For example, did you run a quick self-test of the ATG to verify it's working properly? Or did you check your manual dip stick to make sure it's not warped or worn?
- **Spill Buckets:** Are spill buckets clean, empty, and in good condition?
- **Overfill Alarm (if you have one):** Is your overfill alarm working and easily seen or heard?
- **Impressed Current Cathodic Protection System (if you have one):** Is your cathodic protection system turned on? Are you checking your rectifier at least every 60 days?
- **Fill And Monitoring Ports:** Are covers and caps tightly sealed and locked?
- **Spill And Overfill Response Supplies:** Do you have the appropriate supplies for cleaning up a spill or overfill?

In addition, good UST site management should also include the following quick visual checks:

- **Dispenser Hoses, Nozzles, And Breakaways:** Are they in good condition and working properly?
- **Dispenser And Dispenser Sumps:** Any signs of leaking? Are the sumps clean and empty?
- **Piping Sumps:** Any signs of leaking? Are the sumps clean and empty?

If you find any problems during the inspection, you or your UST contractor need to take action quickly to resolve these problems and avoid serious releases.

A frequent walk-through checklist is provided for your use on the next page.

✓ Frequent Walk-Through Inspection Checklist

Date Of Inspection						
Release Detection System: Inspect for proper operation.						
Spill Buckets: Ensure spill buckets are clean and empty.						
Overfill Alarm: Inspect for proper operation. Can a delivery person hear or see the alarm when it alarms?						
Impressed Current System: Inspect for proper operation.						
Fill And Monitoring Ports: Inspect all fill/monitoring ports and other access points to make sure that the covers and caps are tightly sealed and locked.						
Spill And Overfill Response Supplies: Inventory and inspect the emergency spill response supplies. If the supplies are low, restock the supplies. Inspect supplies for deterioration and improper functioning.						
Dispenser Hoses, Nozzles, And Breakaways: Inspect for loose fittings, deterioration, obvious signs of leakage, and improper functioning.						
Dispenser And Dispenser Sumps: Open each dispenser and inspect all visible piping, fittings, and couplings for any signs of leakage. If any water or product is present, remove it and dispose of it properly. Remove any debris from the sump.						
Piping Sumps: Inspect all visible piping, fittings, and couplings for any signs of leakage. If any water or product is present, remove it and dispose of it properly. Remove any debris from the sump.						

Your initials in each box below the date of the inspection indicate the device/system was inspected and OK on that date.

Section 7 — For More Information

This section identifies UST program contacts and other resources to help answer your questions and provide you with information about good UST management.

Internet Resources

Government Links

- # Directory of State UST Program Contacts: <http://www.epa.gov/oust/states/statcon1.htm>
- # Directory of State UST Program Internet Sites: <http://www.epa.gov/oust/states/stateurl.htm>
- # U.S. Environmental Protection Agency's Office of Underground Storage Tanks Home Page: <http://www.epa.gov/oust>. To go directly to the compliance assistance section of the Home page go to: <http://www.epa.gov/swerust1/cmplastc/index.htm>
- # Tanks Subcommittee of the Association of State and Territorial Solid Waste Management Officials (ASTSWMO): http://www.astswmo.org/programs_tanks.htm
- # New England Interstate Water Pollution Control Commission (NEIWPC): <http://www.neiwpc.org>

Professional And Trade Association Links

- # American Petroleum Institute (API): <http://www.api.org>
- # American Society of Testing and Materials (ASTM): <http://www.astm.org>
- # Fiberglass Tank and Pipe Institute (FTPI): <http://www.fiberglasstankandpipe.com>
- # NACE International - The Corrosion Society: <http://www.nace.org>
- # National Fire Protection Association (NFPA) : <http://www.nfpa.org>
- # Petroleum Equipment Institute (PEI): <http://www.pei.org>
- # Steel Tank Institute (STI): <http://www.steeltank.com>
- # Underwriters Laboratories (UL): <http://www.ul.com>

Free Informative Publications Available

The publications listed below are free and available from the U.S. Environmental Protection Agency (EPA). You can access these publications in the following ways.

- # Go to EPA's web site at <http://www.epa.gov/oust/pubs/index.htm> to order, read, or download documents online.
- # Write and ask for **free** publications by addressing your request to EPA's publication distributor: National Service Center for Environmental Publications (NSCEP), Box 42419, Cincinnati, OH 45242.
- # For **free** copies, call EPA's publication distributor's **toll-free** number at (800) 490-9198. Or go to <http://www.epa.gov/nscep/ordering.htm> for additional ordering methods.

Catalog Of EPA Materials On USTs

An annotated list of UST materials, including ordering information. Most of the leaflets, booklets, videos, and software items listed provide UST owners and operators with information to help them comply with federal UST requirements (32 pages).

Musts For USTs: A Summary Of Federal Regulations For Underground Storage Tank Systems
Plain language summary of federal UST requirements for installation, release detection, spill, overflow, and corrosion protection, corrective action, closure, reporting and recordkeeping. Updated & revised 1995 (36 pages).

Model Underground Storage Tank Environmental Results Program Workbook

Workbook, which states can modify to reflect their laws, helps improve owner and operator compliance with UST regulations. Contains general information about ERP; instructions on how to use the workbook; regulatory requirements, best management practices, and compliance checklists for USTs; and draft forms and worksheets in the appendices (164 pages). (Available on web only)

UST Systems: Inspecting And Maintaining Sumps And Spill Buckets – Practical Help And Checklist

Manual presents recommended inspection guidelines and best management practices for UST system sumps and spill buckets. Includes safety considerations; a general introduction to the kinds of sumps; basic maintenance procedures for sumps and spill buckets; and a sump and spill bucket inspection checklist (16 pages).

Straight Talk On Tanks: Leak Detection Methods For Petroleum Underground Storage Tanks

Explains federal regulatory requirements for leak detection and briefly describes allowable leak detection methods. Updated & revised 2005 (28 pages).

Getting The Most Out Of Your Automatic Tank Gauging System

Trifold leaflet provides UST owners and operators with a basic checklist they can use to make sure their automatic tank gauging systems work effectively and provide compliance with federal leak detection requirements.

Doing Inventory Control Right: For Underground Storage Tanks

Booklet describes how owners and operators of USTs can use inventory control and periodic tightness testing to temporarily meet federal leak detection requirements. Contains recordkeeping forms (16 pages).

Manual Tank Gauging: For Small Underground Storage Tanks

Booklet provides simple, step-by-step directions for conducting manual tank gauging for tanks 2,000 gallons or smaller. Contains recordkeeping forms (12 pages).

List Of Leak Detection Evaluations For UST Systems

A summary of specifications, based on third-party certifications, for over 275 systems that detect leaks from USTs and their piping. Each summary provides information on such items as certified detectable leak rate/threshold, test period duration, product applicability, calibration requirements, restrictions on the use of the device, and so on. (Available on web only)

List Of Integrity Assessment Evaluations For USTs

A list of integrity assessment procedures that have been successfully evaluated and certified by a qualified independent third party to meet specified performance criteria. (Available on web only)

Introduction To Statistical Inventory Reconciliation: For Underground Storage Tanks

Booklet describes how Statistical Inventory Reconciliation (SIR) can meet federal leak detection requirements (12 pages).

Closing Underground Storage Tanks: Brief Facts

Trifold leaflet presents "brief facts" on properly closing USTs in order to comply with federal closure requirements.

Underground Storage Tanks: Requirements And Options

Trifold leaflet alerts UST owners and operators who are "nonmarketers" (who do not sell stored petroleum) that they need either to find alternatives to managing their USTs or to make decisions about UST compliance.

Dollars And Sense: Financial Responsibility Requirements For Underground Storage Tanks

Booklet summarizes the "financial responsibility" required of UST owners and operators (16 pages).

List Of Known Insurance Providers For Underground Storage Tanks

Provides UST owners and operators with a list of insurance providers who may be able to help them comply with financial responsibility requirements by providing suitable insurance mechanisms (12 pages). (Available on web only)

Financing Underground Storage Tank Work: Federal And State Assistance Programs
Booklet identifies potential sources of financial assistance to cover the costs of upgrading, replacing, or closing an UST, or of cleaning up an UST release. Updated and revised March 1999 (23 pages).

State Regulatory Agency Contacts

See EPA's web site at <http://www.epa.gov/oust/states/statcon1.htm> for state underground storage tank program contact information.

Getting The Most Out Of Your Automatic Tank Gauging System

As an owner or operator of an underground storage tank, you have invested a lot of money in your automatic tank gauging system to detect leaks—but are you getting your money's worth?

If you don't operate your automatic tank gauging system (ATGS) effectively, you may be letting stored product leak into the environment. If so, you may face costly cleanups and liability actions. Also, you can be cited and fined for not meeting the federal requirements for properly operating and maintaining an ATGS to detect leaks from underground storage tanks (USTs).

Note that a simple ATGS will detect leaks only from tanks. To detect leaks from piping, you will need an ATGS that supports connection to line leak detectors.

The checklist that follows can help you avoid some common problems and make sure your ATGS is working as required:

- # **Know your ATGS.** Insist that your ATGS installer trains you and provides clear instructions in the proper operation and maintenance of the ATGS.
- # **Make sure your ATGS is constantly "on"** and plugged into a power source. This may sound obvious, but inspectors have written many citations when they discovered that the ATGS was "off" and not monitoring for leaks.

- # **Respond to alarms.** Ignoring an alarm defeats the purpose for having the ATGS. Don't ignore the "FAIL" alarm. Large leaks have gone undetected when operators ignored an alarm or turned their ATGS off.
- # **Run your ATGS in its "test mode"** at least once a month. You must test when tank is relatively full. Since an ATGS does not detect leaks above the product level, test when the tank is as full as it typically gets (try testing soon after delivery, but after product settles). Also, you should test frequently. The more frequently you test, the greater the likelihood you will detect leaks as quickly as possible. The earlier you detect a leak, the easier and less costly the cleanup.
- # **Have your ATGS maintained and calibrated according to manufacturers' instructions.** Make sure you read the directions in the manual that came with your ATGS. Use the manufacturer or installer representative's phone number to get answers to any questions you have about using the ATGS correctly. Don't hesitate to contact the manufacturer or installer for help.
- # **Report problems.** You must report test results indicating a leak to your implementing agency (usually your state environmental agency), generally within 24 hours. You do not need to report if the ATGS is found to be defective, is repaired immediately, recalibrated or replaced, and subsequent monitoring shows tank is tight. You must immediately investigate and confirm all suspected leaks. When in doubt, report.

- # **Keep records.** Federal regulations require you to keep the following records:

Keep for at least one year:

- Monthly test results.
- Documentation of all calibration, maintenance, and repair.

Keep for at least five years:

- Any written performance claim for your ATGS. This will usually be an evaluation document signed by a third-party evaluator showing how a sample ATGS performed under test conditions.
- Manufacturer-supplied schedules for calibration and maintenance.

Keep records either at the UST site or at a readily available alternative site, and provide them for inspection upon request.

- # **Put ATGS monitoring in the most responsible hands.** Do not rely on the vigilance of part-time or under-trained employees. If necessary, have ATGS alarms go to a central, 24-hour contact or use other mechanisms that put ATGS monitoring in the most responsible hands.

Check state and local regulations. State or local regulations may differ from the federal requirements, so find out which requirements apply to your UST. Check with your implementing agency.

Please note: You may need to continue doing monthly inventory control as you use your ATGS. If your ATGS was installed after December 22, 1990 and does not meet performance standards for minimum leak detection rates, you must continue to perform proper inventory control. Check the third-party evaluation of your ATGS to see if it meets the performance standard requiring ATGS to detect a leak of 0.2 gallons per hour with 95% probability of detection and 5% probability of false alarm. **If you are not sure, check with your implementing agency.**

Need More Information?

EPA can provide free, plain-English publications that concisely describe all aspects of federal UST requirements.

To order free publications, determine if your tanks need to meet federal UST requirements, get more information about UST requirements, or identify state regulatory authorities, please call **EPA's toll-free Hotline at 800-424-9346**. Remember, requirements and deadlines may be different in some states, so check with your state UST program office.

You can also find UST publications, links to state regulatory authorities, and other UST information at EPA's Office of Underground Storage Tanks Web site at <http://www.epa.gov/OUST/>

Remember, it's in your best interest that your ATGS works and detects leaks as soon as possible—

before leaks become big cleanup and liability problems.

Protect your ATGS investment by making sure your ATGS installer:

- Trains you in proper operation of the ATGS.
- Demonstrates that the ATGS has been correctly installed and programmed for the tank it monitors.
- Gives you an operation manual, schedules and documentation for calibration/maintenance, third-party evaluation, and phone numbers for technical support.
- Schedules maintenance with you as required by manufacturers' instructions.



Getting The Most Out Of Your Automatic Tank Gauging System

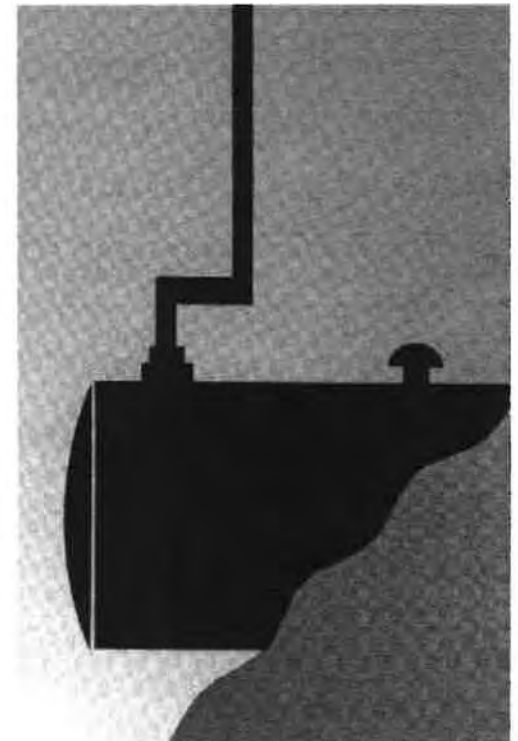



UST Systems: Inspecting And Maintaining Sumps And Spill Buckets

Practical Help And Checklist



Contents

Introduction	1
Who Should Read This Manual?	1
How Will This Manual Help You?	1
Why Should You Care About Sump Maintenance?	1
Safety Considerations	3
Getting To Know Your Sumps	4
What Is A Sump?.....	4
What Kinds Of Sumps Are Associated With My UST System And Where Are They Located?	4
How Do You Access Your Sumps And Spill Buckets?	6
Basic Maintenance Procedures For Sumps And Spill Buckets.....	7
What Can You Do To Ensure Your Sumps and Spill Buckets Are In Good Condition?	7
What Should You Look For When You Inspect Your Turbine, Dispenser, And Transition/Intermediate Sumps?	7
What Should You Look For When You Inspect Your Spill Buckets?	12
Where Can You Get More Information On This Topic?	15

Appendix A: Sample Underground Storage Tank Sump And Spill Bucket Inspection Checklist

This document provides information on inspecting and maintaining sumps and spill buckets. The information provided in this manual is not intended to replace or contradict your specific manufacturer's instructions for maintaining your sumps. Nothing in this manual is intended to endorse or criticize any specific type of equipment or any manufacturer. Photographs of common sump problems are provided for instructional purposes only. This document does not replace existing federal or state regulations, nor is it a regulation itself - it does not impose legally binding requirements. For regulatory requirements regarding UST systems, refer to the federal regulations governing underground storage tank systems (40 CFR Part 280) or corresponding state regulations.

Additional copies of this manual are available at no cost by calling EPA's toll-free distribution center at 800-490-9198. Or you can download a color copy by going to OUST's World Wide Web Home Page at <http://www.epa.gov/oust/pubs>

Introduction

Who Should Read This Manual?

This manual is intended for owners and operators of underground storage tank (UST) systems; specifically, anyone who oversees the operation and maintenance of UST systems that contain and dispense petroleum products. UST owners/operators should ensure that only qualified personnel conduct inspection and maintenance activities.

How Will This Manual Help You?

This manual covers recommended inspection guidelines and best management practices for sumps associated with your UST system. This manual will:

- ❖ Help you identify and inspect the sumps associated with your UST system, including the equipment in your sumps.
- ❖ Explain some simple steps you can take to maintain your sumps and the equipment in your sumps, as well as identify potential problems.
- ❖ Provide you with tips for fixing common problems before they cause a release to the environment.

For more complete guidance on how to operate and maintain your UST system, refer to the U.S. Environmental Protection Agency (EPA) document, *Operating And Maintaining Underground Storage Tank Systems, Practical Help And Checklists (EPA 510-B-05-002, May 2005)*.

Why Should You Care About Sump Maintenance?

Despite advances that have greatly reduced the threat of petroleum releases from UST systems into the environment, some UST systems continue to experience releases. Inadequate operation and maintenance is one reason these systems continue to experience releases.

After reading this manual, you should be able to identify the different types of sumps associated with your UST system and be familiar with how to identify some common sump-related problems.

The average cleanup cost for a leaking UST is about \$100,000. The cost can be more than \$1,000,000 if groundwater is affected.

UST Systems: Inspecting And Maintaining Sumps And Spill Buckets

Sumps, including the sumps beneath dispensers, sumps around the submersible pump (turbine) head¹, transition/intermediate sumps, and spill buckets are common sources of releases. Releases of even small volumes of product can seep into the ground and contaminate soil and groundwater. Inspecting and maintaining your sumps is generally simple and can prevent or minimize such releases.

While this manual addresses a number of issues related to sump maintenance, it may not cover some details specific to your particular sumps. Keep in mind the information provided in this manual is not intended to replace or contradict your specific manufacturer's instructions for maintaining your sumps and the equipment in your sumps.

This manual presents practical help and a checklist for inspecting and maintaining sumps. State and local agencies may require these or other activities. Please check with your state or local agency to determine their specific requirements.

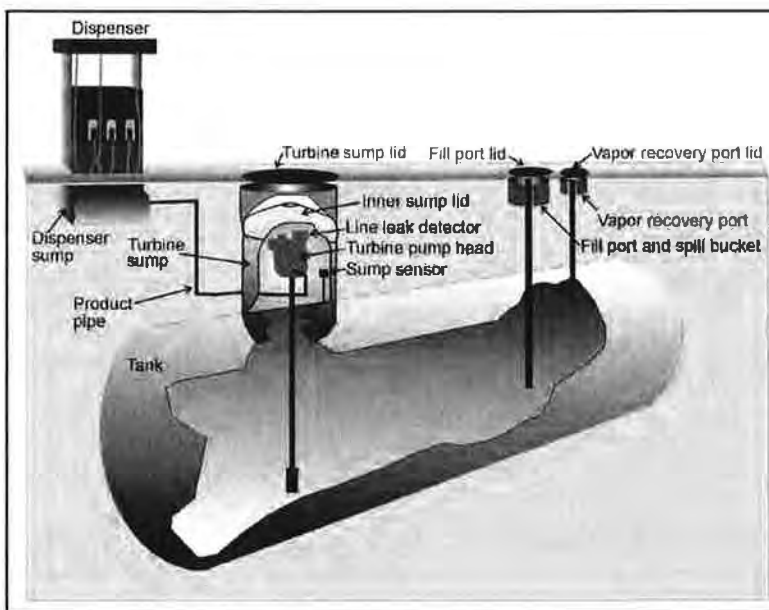

Diagram of an UST system

¹ Submersible turbine pumps are often known by their acronym STP.

Safety Considerations

If you perform sump inspection and maintenance activities, you should be experienced and aware of hazards and safety issues. Chances are you will be working in a high-traffic area, such as a gas station. You should properly mark off your work area and take appropriate steps to protect yourself. You should have the following items:

- ❖ Safety barriers, such as traffic cones or yellow plastic tape to mark off your work area
- ❖ Orange safety vest
- ❖ Hard hat (for construction sites)
- ❖ Steel-toed boots
- ❖ First-aid kit
- ❖ Chemical resistant gloves

You should consider these additional safety precautions:

- ❖ Sump lids may be large and very heavy and may require more than one person to lift. Use caution when lifting large steel lids.
- ❖ Be aware of the possibility of explosive or harmful vapors when inspecting and maintaining sumps. Avoid breathing in petroleum vapors.
- ❖ Please note that OSHA designates some sumps as confined spaces. See OSHA's standard on confined spaces in Title 29 of the *Code of Federal Regulations*, Part 1910.146.
http://www.osha.gov/pls/oshaweb/owadisp.show_document?p_table=STANDARDS&p_id=9797



Person wearing safety gear while inspecting a sump



Person removing a sump lid within a marked inspection area

Getting To Know Your Sumps

What Is A Sump?

A sump is a subsurface area (pit) designed to provide access to equipment located below ground and, when contained, to prevent liquids from releasing into the environment.

Sumps may or may not be contained. Contained sumps have sides and a bottom, are designed to be liquid tight, and may have a special cover designed to keep out water. Uncontained sumps generally do not have a bottom and are not designed to prevent liquid from entering or exiting the sump. These sumps may use wooden or metal sheeting to restrict the slumping of soil or crushed rock onto the equipment and to prevent the surface pavement from buckling or caving.



Uncontained turbine sump

What Kinds Of Sumps Are Associated With My UST System And Where Are They Located?

The types of sumps likely to be associated with your UST system are:

Turbine Sumps – Turbine sumps are designed to provide access to the turbine area above the tank. The turbine area may house the submersible turbine pump head, piping, line leak detectors, interstitial monitoring devices, wiring, and other equipment. You generally will find turbine sumps directly above your USTs. Turbine sump lids generally range from 3 to 4 feet in diameter and can be round, oval, square, or rectangular in shape.



Contained turbine sump

Dispenser Sumps – Dispenser sumps are designed to provide access to piping, flex connectors, shear valves, and other equipment located beneath the dispenser. Dispenser sumps are found directly under your dispensers.



Contained dispenser sump

UST Systems: Inspecting And Maintaining Sumps And Spill Buckets

Transition/Intermediate Sumps – Transition/intermediate sumps are less common than other sumps, but can be found along the piping runs that connect the tanks to the dispensers, and are designed to provide access to the piping. Transition sumps are used to transition from above-ground piping to below-ground piping or, in some cases, to transition between different types of piping. Intermediate sumps are located at key points in the piping system (e.g., low spots, branches, tees). Transition/intermediate sump lids generally range from 3 to 4 feet in diameter and can be round, oval, square, or rectangular in shape.

Spill Buckets – Spill buckets are contained sumps installed at the fill and/or vapor recovery connection points to contain drips and spills of fuel that can occur during delivery. Spill buckets are located where the delivery driver connects the product and/or vapor recovery hoses to your tank. Spill buckets can be found directly above your UST, at a location that is away from your UST (remote), or both. They typically range in size from 5 to 25 gallons, and lids range from 1 to 2 feet in diameter. Spill buckets may also be installed within a larger sump, similar in construction to a turbine sump, for secondary containment. In this case, you will only need to open your smaller lids to access your spill buckets.



Transition/intermediate sump



Spill bucket



Fill and vapor recovery lids installed within a larger sump lid

Spill Bucket Lid

Turbine Sump Lid



View of sump lids

Did You Know?
Most UST systems must have spill buckets at each fill pipe where fuel is delivered into the UST. Some facilities also may have a second spill bucket around the Stage I vapor recovery line.

How Do You Access Your Sumps And Spill Buckets?

You may need tools such as a large screwdriver, pry bar, wrench, or hammer to open your sump lids. Composite lids may require a specialized tool that you probably have on site. Have someone help you in lifting large lids, as they may be very heavy. Use caution when opening the lids and be aware of the following:

- ❖ Square, rectangular, or oval sump lids can fall through the opening and damage the piping, submersible pump, or tank.
- ❖ Round lids, while not typically capable of falling into the sump, may swing down and damage the turbine head or line leak detector.
- ❖ If applicable, follow your equipment manufacturer's recommendations if special instructions are necessary to open the sump lids.
- ❖ You may need a key to remove the dispenser cover in order to access the dispenser sumps.

Generally, sumps will have a traffic load rated lid, beneath which may be either direct access to the equipment or, if contained, an inner lid covering the contained area.



Circular steel sump lid pulled back to show the inner lid covering the turbine sump



Square steel sump lid pulled up to show the inside of an uncontained turbine sump



Circular spill bucket lid pulled back to show the fill port with a spill bucket



Dispenser cover pulled off to show the dispenser piping and equipment

Basic Maintenance Procedures For Sumps And Spill Buckets

What Can You Do To Ensure Your Sumps and Spill Buckets Are In Good Condition?

Maintaining your sumps and spill buckets will involve gaining access to them, inspecting them on a regular basis, assessing whether any problems exist, and ensuring any problems are addressed. For serious problems (e.g., obvious leaks occurring on the piping and equipment, cracked spill buckets or sidewalls, cracked or missing seal around the lid), it's best to contact your UST contractor or the manufacturer of your UST equipment to have the problem fixed. Appendix A contains a sample checklist you may want to use to guide your sump inspections.

What Should You Look For When You Inspect Your Turbine, Dispenser, And Transition/Intermediate Sumps?

Are The Lids Tight And Sealed Correctly? Check to ensure the lids to the turbine, transition, and intermediate sumps create a tight seal when closed and are securely fastened. The seals of the sump lids often dry out, crack, and require replacement; so you need to ensure they are in good condition. Water in your sumps may be an indication of a bad seal.

Are The Sump Walls Intact? Check to ensure the walls of your sump are intact and are not slumping or warping. If your sump is not contained, check the sidewalls to ensure there is no caving.

Note: To avoid accumulation of surface water, you should check the seals of your sumps' lids more frequently if they are located at a low point on the property or in the path of surface water runoff.

If you identify or suspect a release of fuel to the environment, report this to your implementing agency. For a list of state UST websites, go to: <http://www.epa.gov/oust/states/statcon1.htm>



Contained turbine sump full of liquid

UST Systems: Inspecting And Maintaining Sumps And Spill Buckets

Is The Sump Free Of Debris, Liquid, Or Ice? Debris, liquid, and ice can damage equipment, reduce capacity (if contained), and interfere with your equipment's ability to operate correctly. For example, water in your sump will reduce capacity and may cause metal equipment in your sump to corrode. Fuel in your sump will also reduce capacity and may damage some plastic sumps and other components not designed for long term contact with petroleum. Similarly, used dispenser filters may contain small amounts of petroleum, so they should not be left inside your sump. You should carefully remove and properly dispose of any debris, liquid, or ice in your sumps.

Did You Know?
Some sensors may alarm only when in contact with petroleum. If covered completely with water, they will not alarm, even in the event of a petroleum leak.



Dry, debris-free contained turbine sump



Contained sump with liquid and debris

Is The Sump Free Of Cracks Or Holes? Examine your contained sumps for signs of damage (e.g., cracks or holes). Check to ensure no cracks are present around the areas where components, such as wiring conduit and piping, enter your sumps. Cracks and holes mean your sump will no longer contain product or prevent releases to the environment.

Are Sump Components Leak-Free? Check to ensure the piping, fittings, and connections in your sump are not leaking or dripping fuel.

Is The Sump Free Of Staining/New Staining? Check to ensure no new stains are present since your last inspection. New staining indicates a drip or spill has occurred.



Staining

UST Systems: Inspecting And Maintaining Sumps And Spill Buckets

Are The Sensors Positioned Correctly?² If you have sensors, check to ensure they are positioned properly in the lowest part of your sump and below the piping entry. Sensors should not be raised as the result of false alarms or for any other reason. Raised or disabled sensors will take longer or fail to detect a leak and could violate regulatory requirements.



Sump sensor

Sump sensor in contained turbine sump



Float sump sensor



Liquid sump sensor

Are All Penetrations Into The Sump In Good Condition?² Check to ensure all areas where electrical wires, conduits, and piping enter the sump are sealed. Cracked or loose seals around the penetrations can allow liquids to enter the sump and can allow fuel to be released into the surrounding soils if a release occurs inside the sump.



Sump penetration seals in poor condition



Sump penetration seals in good condition

Did You Know?

A crack or hole in your sump below the sump sensor will not allow liquid to accumulate in the sump to a level necessary to activate the sensor. As a result, liquid may be released undetected. Such cracks or holes need to be repaired immediately.

Did You Know?

Some plastic flexible piping is installed within a larger pipe (or chase). There may be a seal between the primary pipe and the chase. Check with the piping maker to determine the proper position of the seal.

² Only for contained sumps

UST Systems: Inspecting And Maintaining Sumps And Spill Buckets

Are The Test Boots Positioned Correctly And In Good Condition?³ A test boot is found on secondarily-contained piping and is a flexible sleeve usually made of rubber with a valve located either at the entry to the sump or on the piping in the sump. It is used to test the space between the inner and outer piping walls for tightness. Check to ensure the test boots are in good condition, not cracked or torn, and positioned correctly in the sump.

To ensure a leak can be detected by your leak detection equipment, test boots should be positioned so they allow product to enter your sump if a leak from the primary piping occurs. There are a variety of different configurations for test boots. If you are unsure of the appropriate configuration, check with your contractor.



Test boot located in a sump



Test boots positioned at sump wall, right test boot is torn

Is The Piping And Other Equipment In Good Condition?

Sumps may contain various types of piping and equipment such as leak detection equipment, turbine motors, line leak detectors, sensors, conduits, and flex connectors.



Contained turbine sumps and equipment in good condition

Did You Know?
If your metal piping, including metal flex connectors, is in contact with the ground, it must be protected from corrosion.

³ Typically only for contained sumps

UST Systems: Inspecting And Maintaining Sumps And Spill Buckets

When inspecting the piping and equipment in your sumps, you should watch for the following conditions:

- ❖ For metal piping, check to ensure the piping is not severely corroded, in contact with the ground if it does not have corrosion protection, or otherwise degraded.
- ❖ For fiberglass piping, check to ensure the piping is not cracked, delaminated, or otherwise degraded.
- ❖ For flexible piping, check to ensure the piping does not have abnormal bends, breaks, cracks, or kinks; is not bulging, swelling, or growing; has not become soft, spongy, or discolored; and is not otherwise distorted or degraded.
- ❖ Check to ensure the fittings and flexible connectors are not twisted or misaligned and the flexible connectors are not cracked, kinked, etc.
- ❖ Check to ensure other pieces of equipment, including pump head, line leak detector, and sensors, are not visibly damaged, severely corroded, etc.



Equipment and metal piping covered with dirt in uncontained sump



Fiberglass piping is cracked



Flexible piping is degraded due to microbial growth



Flexible piping is cracked



Flexible piping is kinked



Metal flexible connector is twisted due to growth of flexible plastic piping



Flexible piping is bulging

What Should You Look For When You Inspect Your Spill Buckets?

Are The Lids To Your Spill Buckets In Good Condition? Check to ensure the lids to your spill buckets are in good condition so they will keep water out when the lid is closed. Ensure that when the lids to your spill buckets are in the closed position, they create a good seal and are secured tightly. Some spill buckets contain a rubber gasket inside the cover; check to ensure the rubber gasket is in good condition and creates a proper seal when the lid is closed.



Cracked spill bucket lid



Spill bucket lid gasket

Check to ensure the lid is not touching the fill cap. This situation should be repaired because it could potentially damage the fill pipe and the tank if it is in an area where vehicles drive over the lid.

Is The Spill Bucket Free Of Debris, Liquid, Or Ice? Examine your spill buckets to determine whether they contain debris, liquid, or ice. For example, water in your spill bucket will reduce capacity and may cause metal equipment in your sump to corrode. Fuel in your spill bucket will also reduce capacity and may damage some plastic spill buckets not designed for long term contact with petroleum. You should carefully remove and properly dispose of any debris, liquid, or ice found in your spill buckets during your inspections. You should also check for and remove any liquid and debris present in your spill buckets before and after every delivery.

A missing or damaged spill bucket lid may be a safety hazard. Replace it as soon as possible. Until the lid is replaced, cover and barricade the area to prevent potential accidents.



Spill bucket that contains liquid

UST Systems: Inspecting And Maintaining Sumps And Spill Buckets

Some spill buckets are equipped with a valve that allows you to drain accumulated liquid into your UST. Others may be equipped with a manual pump so fuel can be transferred to your UST system by pumping it through the fill pipe or removing the fuel and disposing of it properly. However, keep in mind that when you pump out or drain your spill bucket into your UST, any water and debris present also will enter the UST. This could lead to internal corrosion, dispensing problems, and the need to remove contaminated water from the tank. If your spill bucket is not equipped with a drain valve or pump, you can still remove the liquid and debris and dispose of them appropriately. Liquid can be removed with a portable pump, such as the one on the right.



Portable pump

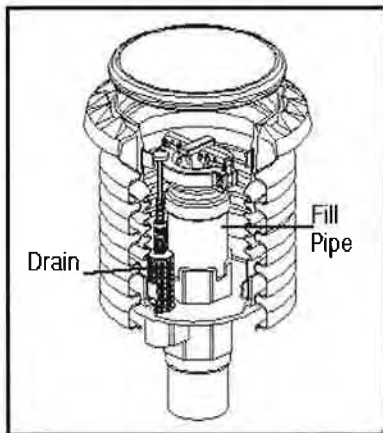

Spill bucket with a drain valve

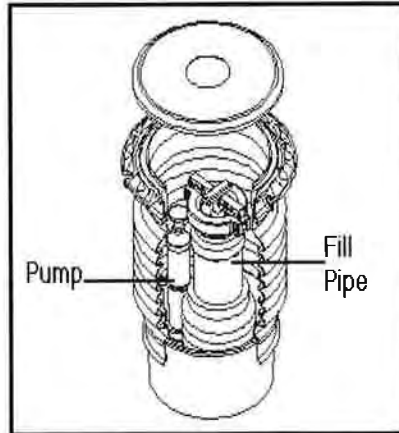

Spill bucket with a manual pump

If your spill bucket is always dry, this may be an indication that it is not able to contain product. You may need to test to ensure it is liquid tight.

Is The Spill Bucket Free Of Cracks Or Holes? Examine the spill buckets for evidence of cracks or holes. If you have a metal bucket, check for corrosion and rust. Also check for deformations in the spill buckets or separation of the spill bucket from the fill pipe.



Spill bucket in poor condition – note the gap between the spill bucket and the fill pipe

UST Systems: Inspecting And Maintaining Sumps And Spill Buckets

Are The Drain Valves Operational? Some spill buckets have drain valves. Check to ensure the drain valve is free of debris and operational (e.g., it can close tightly and be opened to drain fuel in the spill bucket). If the drain valve is left open:

- ❖ It will act as a vent
 - Possibly affecting the ability of your overfill device to function properly;
 - Allowing potentially dangerous vapors to build up in the spill bucket or to be released to the soil or groundwater;
 - Possibly affecting the operation of the Stage II vapor recovery system.
- ❖ It can allow water and debris to enter your tank.



Spill bucket drain valve

Never pump fuel from your spill buckets into storm or sewer drains as a method of disposal. Improper disposal can contaminate surface and groundwater, result in vapor/explosion hazards, damage sewage treatment plants, and may be in violation of state or federal law.

Where Can You Get More Information On This Topic?

Federal Agencies

U.S. EPA
Office of Underground Storage Tanks
<http://www.epa.gov/oust>

U.S. Department of Labor
Occupational Safety and Health Administration
<http://www.osha.gov>
1-800-321-OSHA (6742)

Organizations

API - American Petroleum Institute
www.api.org
(202) 682-8000

FTPI - Fiberglass Tank and Pipe Institute
www.fiberglassstankandpipe.com
(281) 568-4100

NACE International - Formerly National Association of
Corrosion Engineers
www.nace.org
(281) 228-6200

NFPA - National Fire Protection Association
www.nfpa.org
(617) 770-3000

PEI - Petroleum Equipment Institute
www.pei.org
(918) 494-9696

STI - Steel Tank Institute
www.steeltank.com
(847) 438-8265

Publications

The publications listed below are free and available from the U.S. EPA. You can access these publications via EPA's website or you can call, write to, or fax EPA.

- ❖ You can download, read, or order documents from <http://www.epa.gov/oust/pubs/index.htm>
- ❖ To order free copies or ask questions, call EPA's publication distribution toll-free number at 800-490-9198 or fax 301-604-3408. You can also write and ask for free publications by addressing your request to EPA's publication distributor: National Service Center for Environmental Publications (NSCEP), Box 42419, Cincinnati, OH 45242.

Operating and Maintaining Underground Storage Tank Systems: Practical Help and Checklists, U.S. EPA, Office of Underground Storage Tanks, Washington DC, EPA 510-B-05-002, May 2005.

Musts for USTs: A Summary of the New Regulations for Underground Storage Tank Systems, U.S. EPA, Solid Waste and Emergency Response, Washington DC, EPA-510-K-95-002, July 1995.

Model Underground Storage Tank Environmental Results Program Workbook, U.S. EPA, Solid Waste and Emergency Response, Washington DC, EPA R-04-003, June 2004.

Other Sources

For additional information on UST system operation and maintenance, go to U.S. EPA Office of Underground Storage Tanks, List of Operation and Maintenance Tools
<http://www.epa.gov/oust/ustsystem/tanko&m.htm>

For links to state UST websites go to
<http://www.epa.gov/oust/states/statcon1.htm>

Appendix A

Note: Federal UST regulations do not require you to report your maintenance activities, use this form, or keep any specific records of your sump inspection and maintenance practices.

Sample Underground Storage Tank Sump And Spill Bucket Inspection Checklist

Name: _____ Date/Time Of Inspection: _____

Comments/Follow-Up Needed: _____

Choose yes or no for each question that applies.
 Choosing no on any item indicates a problem that should be corrected.
 When you have corrected the problem, check the fixed box.

Turbine/Transition/Intermediate Sumps	Sump No.: _____			Sump No.: _____			Sump No.: _____			Sump No.: _____		
	Yes	No	Fixed?	Yes	No	Fixed?	Yes	No	Fixed?	Yes	No	Fixed?
Are The Lids Tight And Sealed Correctly?			<input type="checkbox"/>			<input type="checkbox"/>			<input type="checkbox"/>			<input type="checkbox"/>
Are The Sump Walls Intact?			<input type="checkbox"/>			<input type="checkbox"/>			<input type="checkbox"/>			<input type="checkbox"/>
Is The Sump Free Of Debris, Liquid, Or Ice?			<input type="checkbox"/>			<input type="checkbox"/>			<input type="checkbox"/>			<input type="checkbox"/>
Is The Sump Free Of Cracks Or Holes?*			<input type="checkbox"/>			<input type="checkbox"/>			<input type="checkbox"/>			<input type="checkbox"/>
Are Sump Components Leak-Free (No Leak Or Drips)?			<input type="checkbox"/>			<input type="checkbox"/>			<input type="checkbox"/>			<input type="checkbox"/>
Is The Sump Free Of Staining/New Staining?			<input type="checkbox"/>			<input type="checkbox"/>			<input type="checkbox"/>			<input type="checkbox"/>
Are The Sensors Positioned Correctly?*			<input type="checkbox"/>			<input type="checkbox"/>			<input type="checkbox"/>			<input type="checkbox"/>
Are All Penetrations Into The Sump In Good Condition?*			<input type="checkbox"/>			<input type="checkbox"/>			<input type="checkbox"/>			<input type="checkbox"/>
Are The Test Boots Positioned Correctly And In Good Condition?*			<input type="checkbox"/>			<input type="checkbox"/>			<input type="checkbox"/>			<input type="checkbox"/>
Is The Piping And Other Equipment In Good Condition?			<input type="checkbox"/>			<input type="checkbox"/>			<input type="checkbox"/>			<input type="checkbox"/>
Dispenser Sumps	Dispenser No.: _____			Dispenser No.: _____			Dispense No.: _____			Dispenser No.: _____		
	Yes	No	Fixed?	Yes	No	Fixed?	Yes	No	Fixed?	Yes	No	Fixed?
Is The Sump Free Of Debris, Liquid, Or Ice In The Sump?			<input type="checkbox"/>			<input type="checkbox"/>			<input type="checkbox"/>			<input type="checkbox"/>
Is The Sump Free Of Cracks Or Holes?			<input type="checkbox"/>			<input type="checkbox"/>			<input type="checkbox"/>			<input type="checkbox"/>
Are Sump Components Leak-Free (No Leak Or Drips)?			<input type="checkbox"/>			<input type="checkbox"/>			<input type="checkbox"/>			<input type="checkbox"/>
Is The Sump Free Of Staining/New Staining?			<input type="checkbox"/>			<input type="checkbox"/>			<input type="checkbox"/>			<input type="checkbox"/>
Are The Sensors Positioned Correctly?			<input type="checkbox"/>			<input type="checkbox"/>			<input type="checkbox"/>			<input type="checkbox"/>
Are All Penetrations Into The Sump In Good Condition?			<input type="checkbox"/>			<input type="checkbox"/>			<input type="checkbox"/>			<input type="checkbox"/>
Are The Test Boots Positioned Correctly And In Good Condition?			<input type="checkbox"/>			<input type="checkbox"/>			<input type="checkbox"/>			<input type="checkbox"/>
Is The Piping And Other Equipment In Good Condition?			<input type="checkbox"/>			<input type="checkbox"/>			<input type="checkbox"/>			<input type="checkbox"/>
Spill Buckets	Bucket No.: _____			Bucket No.: _____			Bucket No.: _____			Bucket No.: _____		
	Yes	No	Fixed?	Yes	No	Fixed?	Yes	No	Fixed?	Yes	No	Fixed?
Are The Lids To Your Spill Buckets In Good Condition?			<input type="checkbox"/>			<input type="checkbox"/>			<input type="checkbox"/>			<input type="checkbox"/>
Is The Spill Bucket Free Of Debris, Liquid, Or Ice?			<input type="checkbox"/>			<input type="checkbox"/>			<input type="checkbox"/>			<input type="checkbox"/>
Is The Spill Bucket Free Of Cracks Or Holes?			<input type="checkbox"/>			<input type="checkbox"/>			<input type="checkbox"/>			<input type="checkbox"/>
Are The Drain Valves Operational?			<input type="checkbox"/>			<input type="checkbox"/>			<input type="checkbox"/>			<input type="checkbox"/>

*Only for contained sumps

Helpful
Hints For
Maintaining
Spill
Buckets



Doing Inventory Control Right

For Underground Storage Tanks

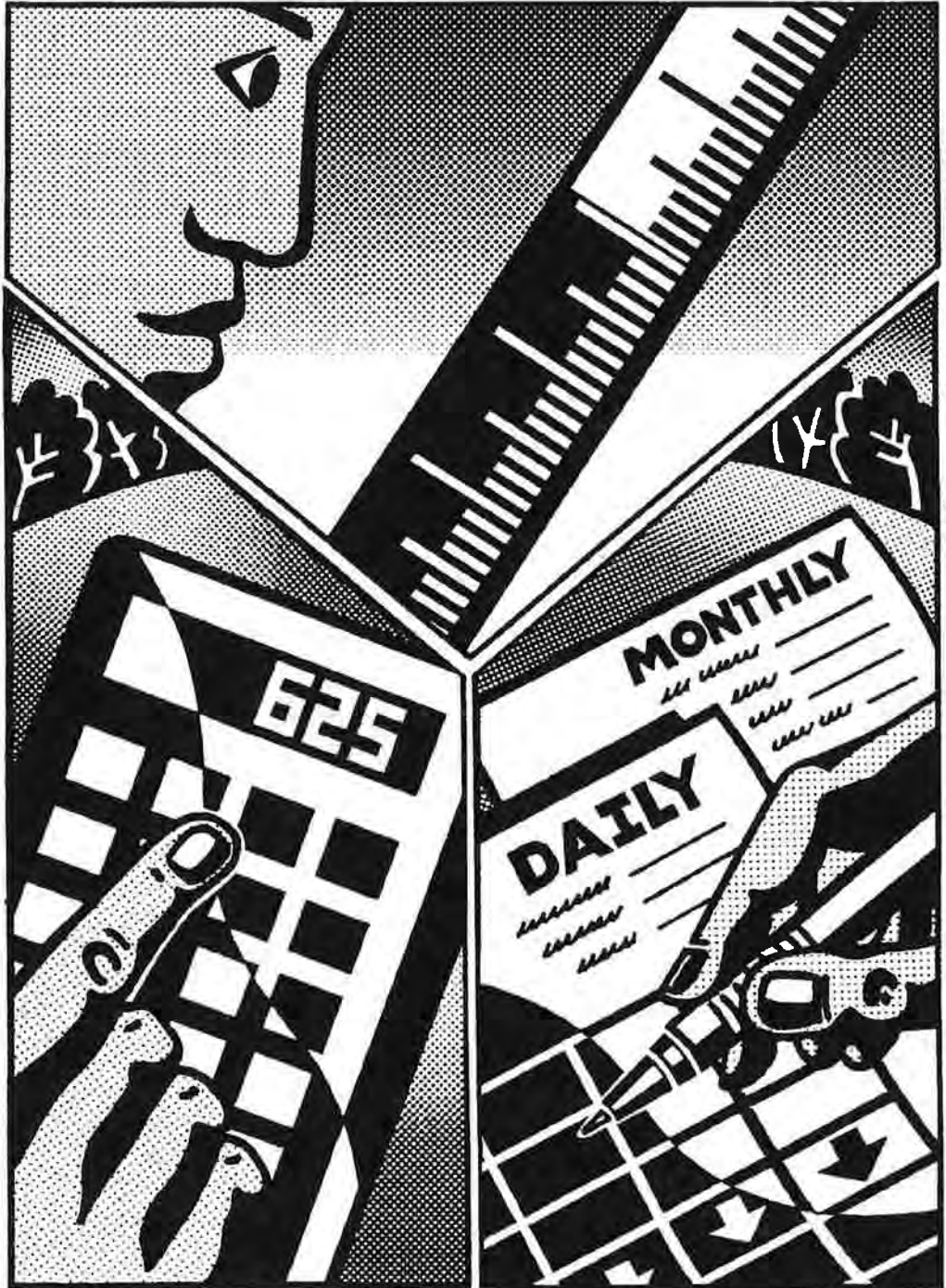

CONTENTS

Why You Should Read This Booklet If You Use Inventory Control	1
How Does Inventory Control Work?	2
Do You Have The Right Equipment?	4
Step 1 — Measure The Tank's Contents	6
Step 2 — Record The Amount Pumped	7
Step 3 — Record Fuel Deliverables	8
Using Tank Charts Without 1/8-Inch Conversions	9
Step 4 — Calculate Daily Change In Inventory	10
Step 5 — Calculate Monthly Changes In Inventory	12

Why You Should Read This Booklet If You Use Inventory Control

Federal and state laws require underground storage tanks (USTs) to have leak detection.

If your USTs do not have leak detection, you can be cited for violations and fined. Leak detection violations can also keep you from getting legally required insurance coverage and reimbursement for cleanup costs. Without leak detection, you constantly risk discovering a leak only after it becomes a major financial burden for yourself and an environmental problem for everyone.

If inventory control is part of your leak detection, then this booklet can help you make sure you do inventory control correctly.

Inspections conducted nationwide indicate that most people who think they are doing inventory control are not doing it in a way that is likely to find leaks and meet the law's requirements for leak detection. So even if you are SURE you are doing inventory control right, read this booklet carefully—it could save you a lot of grief and money.

If you need information on federal leak detection requirements and the various methods of leak detection available to you, see "Straight Talk On Tanks." Call EPA's toll-free Hotline at 800 424-9346 and order this free publication by number: EPA 530/UST-90/012.

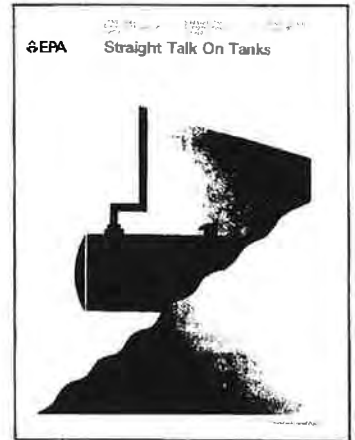

How Does Inventory Control Work?



This booklet helps you use inventory control to meet federal regulatory leak detection requirements by showing you how to do three important tasks:

- ! Good sticking
- ! Good math
- ! Good recordkeeping



Without these three, you may fail to meet the leak detection requirements. To do inventory control right, you have to spend time to make sure that you consistently measure the tank's contents correctly, that you don't let math errors creep into your daily and monthly calculations, and that you keep complete, easy-to-read records on file for at least a year.

Basically, inventory control requires daily measurements of tank contents and math calculations that let you compare your "**stick**" inventory (what you've measured) to your "**book**" inventory (what your recordkeeping indicates you should have). Some people call this process "inventory reconciliation." If the difference between your "**stick**" and "**book**" inventory is too large, your tank may be leaking.



Be sure you read about several important restrictions on the use of inventory control that are described on the next page.

***To use INVENTORY CONTROL correctly,
follow Steps 1—5 starting on page 6.***

Please note these important restrictions on the use of inventory control as leak detection:

- ! **Inventory control can never be used alone.** Inventory control must always be used in combination with tank tightness testing. Tanks must be tightness tested every 12 months if they do not have corrosion protection and spill/overflow devices. Tanks with corrosion protection and spill/overflow devices must be tested every 5 years.

- ! **Inventory control is a TEMPORARY leak detection method.** You can use inventory control only for 10 years after installing a new tank that has corrosion protection and spill/overflow devices or for 10 years after upgrading an old tank with corrosion protection and spill/overflow devices. After the 10-year period, you must use a monthly monitoring method, such as groundwater monitoring or interstitial monitoring.

Tanks without corrosion protection and spill/overflow devices can use inventory control only until December 1998, when these tanks must be upgraded or closed. (See "Straight Talk On Tanks.")

- ! **The combined use of inventory control and tank tightness testing does not meet your tank system's leak detection requirements for piping.** Pressurized and some suction piping must use other methods of leak detection, such as interstitial monitoring. (See "Straight Talk On Tanks.")

If you don't pay careful attention to these restrictions, you will fail to meet the leak detection requirements.

Do You Have The Right Equipment?

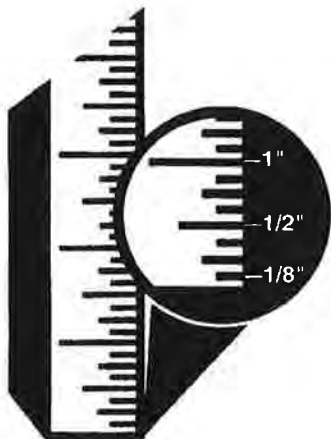

Gauge Stick Or Other Gauges

The gauge stick used to measure the depth of liquid in an underground tank must be marked or notched to the $\frac{1}{8}$ inch, starting with zero at the bottom end. Check your stick to be sure the end has not been worn or cut off and that the stick is not warped. The stick should be made of non-sparking material, such as wood, and varnished to minimize the creeping of fuel above the actual fuel level in the tank. Instead of using a gauge stick, you may use a mechanical or electronic tank level monitor. Whatever measuring device you use must be capable of measuring the level of product over the full range of the tank's height to the nearest $\frac{1}{8}$ inch.



Pastes For Finding Water Or Fuel

You must check for water in the bottom of the tank at least once each month by smearing a water-finding paste along the bottom of the gauge stick. The paste changes color when it comes in contact with water. Many operators improve their stick readings by smearing a fuel-finding paste on about 6 inches of the stick where they expect the fuel level to be. Fuel-finding paste changes color when it comes in contact with fuel.

Forms

The instructions in this booklet are keyed to two forms: the "DAILY INVENTORY WORKSHEET" and the "MONTHLY INVENTORY RECORD." You will find filled-in sample copies of these forms on the last two pages of this booklet. These samples are on perforated pages, so tear them out and refer to them while you read through the directions that are keyed alphabetically to the sample forms. Also, **near the back of the booklet, you will find "masters" you can copy repeatedly to provide forms for use in your recordkeeping.** If these forms are filled out according to the instructions in this booklet, you will be in compliance with federal regulations for inventory control. You should find out if state or local requirements have limitations on the use of inventory control or have requirements that are different from those presented in this booklet. You can use other standard recordkeeping forms, as long as they are clear, consistent, and contain all the information required by the federal and state leak detection regulations.



Tank Chart

A tank chart is a table that converts the number of inches of liquid in the tank into the number of gallons. You need a tank chart that exactly matches your storage tank (tank manufacturers usually provide charts for their tanks). If you have more than one tank, you will need a chart for each tank unless the tanks are identical. The tank chart must show conversion to gallons for each $\frac{1}{8}$ inch stick reading. If your tank chart does not convert each $\frac{1}{8}$ inch reading into gallons, contact the tank manufacturer, or, if you have a steel tank, the Steel Tank Association (708 438-8265) to get an appropriate chart.

You always need to convert inches into gallons in order to fill out the forms correctly and to do the necessary math. To convert inches into gallons, find your stick's reading to the nearest $\frac{1}{8}$ inch on the tank chart, then simply read across to the gallons column to find the number of gallons. If you cannot get a tank chart showing conversion to gallons for each $\frac{1}{8}$ inch reading, you must do the additional math explained on page 9.

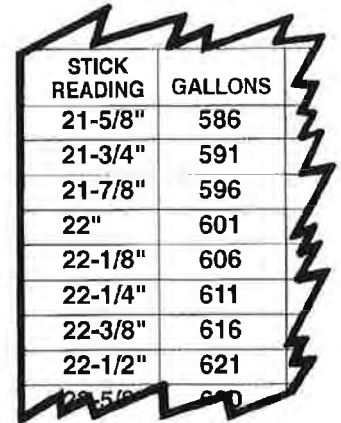

STICK READING	GALLONS
21-5/8"	586
21-3/4"	591
21-7/8"	596
22"	601
22-1/8"	606
22-1/4"	611
22-3/8"	616
22-1/2"	621

Drop Tube

The fill pipe through which the fuel is delivered into the tank must have a drop tube extending to within 1 foot of the bottom of the tank. Stick measurements should be made through a drop tube in the fill pipe or gauging port. If your fill pipe does not have a drop tube, call your petroleum equipment supplier to have one installed.

Calibrated Dispensing Meters

Meters must be calibrated according to local standards.

Manifolded Tanks

If you have manifolded tanks or dispensers that blend fuel, consider these tanks as one tank system if they share a common inventory of stored fuel. As you follow the directions on the following pages, you will need to combine your measurements and calculations for all the tanks manifolded into one system.

Step 1—Measure The Tank's Contents

You must measure the tank every day that fuel is added or removed. You may take measurements using a gauge stick or a mechanical or electronic tank level monitor.

No fuel can be added or removed from the tank while you are performing Step 1 or Step 2.

Every day you measure the tank, you should fill out a "DAILY INVENTORY WORKSHEET." As you go through the following directions, refer to the sample DAILY INVENTORY WORKSHEET you will find on the last pages of this booklet. For easy reference, the sample is on a perforated page so you can tear it out and keep it handy as you read through the directions. Also, near the back of the booklet is a "master copy" on a perforated page you can tear out to make copies of the DAILY INVENTORY WORKSHEET for your recordkeeping.

Use the sample "DAILY INVENTORY WORKSHEET" from the last two pages of the booklet to see where you put the information from letters "A" through "M" in the following directions.

- A** Fill in the identifying information at the top of the worksheet.
- B** Next to the "TANK IDENTIFICATION" box are empty vertical columns. Each column represents one tank—consistently enter all information on that one tank in the same vertical column. NOTE: Once you have filled in the tank identification boxes, make copies of the worksheet so you won't have to repeatedly enter the same information.

USE GOOD STICKING PRACTICES: Slowly lower the gauge stick to the tank's bottom. Let the stick gently touch the bottom, then quickly bring it back up. Read the depth of fuel indicated by the wet mark to the closest $\frac{1}{8}$ inch division on the stick. Use of fuel-finding paste will make your stick readings more accurate.



- C** Write your measurement in the box labeled "END STICK INCHES" for the tank you measured.

NOTE: If your tank is equipped with an automatic tank gauge (ATG), you may record the inches of product and gallons of product directly from the ATG's printed tape or simply staple the tape with this information to the worksheet.

Step 2—Record The Amount Pumped

At the same time you measure the tank contents (Step 1), you must record on the DAILY INVENTORY WORKSHEET the amount of fuel pumped. **No fuel can be added or removed from the tank while you are sticking the tank and recording the amount pumped.**



- D** Locate the box labeled "AMOUNT PUMPED" on the left side of the worksheet. Copy the numbers from each dispenser's totalizer onto the worksheet. **Be very careful that you write all the meter readings for a tank in the same column.** You may have several dispensers and totalizers for one tank, so the worksheet provides boxes in which you can enter several readings in any order.
- E** Add up the totalizer meter readings in each column and write the result in the box labeled "TODAY'S SUM OF TOTALIZERS."
- F** Find the last DAILY INVENTORY WORKSHEET you completed. Copy "TODAY'S SUM OF TOTALIZERS" from that worksheet into the "Previous Day's Sum of Totalizers" box of the worksheet you are working on today.
- G** On today's worksheet, subtract "Previous Day's Sum of Totalizers" from "TODAY'S SUM OF TOTALIZERS" and write the result in the box labeled "AMOUNT PUMPED TODAY."

You may have an alternative to reading totalizers. If you have a self-service fueling operation where the cashier can authorize fuel sales from inside the facility, you can probably print out a daily report that gives you the total sales for each type of fuel. **NOTE: You can use the sales volumes from this report instead of reading your totalizer meters only if no fuel sales are made between the time you print the report from the cash register and the time you measure your tanks (Step 1).**

If you pumped fuel through a dispenser and back into a tank, for example during a test, subtract the number of gallons you pumped from "AMOUNT PUMPED TODAY."

- H** If you are using cash register reports to record the amount pumped, enter the amount of each type of fuel pumped in the box labeled "AMOUNT PUMPED TODAY" or staple the printout to the worksheet.

Step 3—Record Fuel Deliveries



You must check how much fuel has been delivered every time any amount of fuel is delivered to your tank. **NOTE: You should not pump any fuel during the time it takes to do items "I" and "J" below.**

Before the delivery begins, the liquid level in the tank must be measured. Always use good sticking practices: slowly lower the gauge stick, gently touch the stick to the bottom of the tank, then quickly bring the stick back up. Read the depth of fuel indicated by the wet mark to the nearest $\frac{1}{2}$ inch division on the stick.

- I Write your measurement in the box labeled "Inches of Fuel Before Delivery" for each tank you measured.

The delivery person can now deliver fuel into the tank. After the delivery, wait at least 5 minutes for the fuel level in the tank to stabilize, and then measure again as described above.

- J Record fuel level in the box labeled "Inches of Fuel After Delivery."
- K Using your tank chart with $\frac{1}{2}$ inch readings, convert both delivery readings to the correct number of gallons. Record these numbers in the boxes labeled "Gallons of Fuel Before Delivery" and "Gallons of Fuel After Delivery." (If necessary, see page 9 on converting inches into gallons.)
- L Subtract "Gallons of Fuel Before Delivery" from "Gallons of Fuel After Delivery." Record the result in the box labeled "GALLONS DELIVERED (STICK)."

Now look at the delivery receipt and find the volume of each type of product that was delivered. If two volumes are given, one labeled "net" and the other "gross," use the gross gallons as the volume of product delivered.

- M For each type of fuel delivered, copy the gross gallons delivered from the delivery receipt onto the worksheet in the box labeled "GROSS GALLONS DELIVERED (RECEIPT)." The gallons in items "L" and "M" should roughly match. If they don't, contact your supplier.

An automatic tank gauge (ATG) can usually print a delivery report. If your tank has an ATG that prints such a report, you may simply staple the ATG's delivery report to the DAILY INVENTORY WORKSHEET.

Using Tank Charts Without $\frac{1}{8}$ Inch Conversions

If your tank chart does not list direct conversions from inches to gallons for every $\frac{1}{8}$ inch, then you must **do the additional math described below every time you stick your tank.**

The easiest way to explain this procedure is with an example. Let's say you have a stick reading of 43 $\frac{1}{8}$ inches and you need to figure how many gallons are in your tank.

STICK READING	GALLONS
42"	3379
43"	3480
44"	3585
45"	3685
46"	3779
47"	3865

1. Look on your tank chart and find the inch measurements that are just above and below your stick reading and write down the number of gallons for these inch readings. Subtract the gallon readings to find the difference between the two readings:

Chart reading at 44 inches:	3,585 gallons
Chart reading at 43 inches:	3,480 gallons
<hr/>	
Difference:	105 gallons

2. Dividing 105 by 8 will give you the number of gallons per $\frac{1}{8}$ inch, which in this example is 13. (More exactly it is 13.125, but do round off the number to the nearest whole number.) Because your fraction is $\frac{1}{8}$, multiply 13 gallons by 3, which gives you 39 gallons as the volume represented by $\frac{1}{8}$ inch.

CAUTION: The gallons represented by each $\frac{1}{8}$ inch will vary from top to bottom of the tank and must be calculated for each conversion.

3. Take the number of gallons you have just calculated and add it to the inch reading just below your actual stick reading:

Chart reading at 43 inches:	3,480 gallons
Gallons at $\frac{1}{8}$ inch:	+ 39 gallons
<hr/>	
Sum:	3,519 gallons

Thus, your stick reading of 43 $\frac{1}{8}$ inches converts to 3,519 gallons.

NOTE: If your tank chart is in half or quarter inches, you must still use this procedure so that your gallon readings are accurate to $\frac{1}{8}$ inch.

After all of this math, you can see why it pays to have the correct tank chart that indicates gallons for each $\frac{1}{8}$ inch.

Step 4—Calculate Daily Changes In Inventory

In this step, you will copy information from the DAILY INVENTORY WORKSHEET onto the MONTHLY INVENTORY RECORD. You will then do some math to determine your daily inventory. You need one MONTHLY INVENTORY RECORD for each tank that you have.

As you go through the following directions, refer to the sample MONTHLY INVENTORY RECORD you will find on the reverse side of the DAILY INVENTORY WORKSHEET sample you have already been using. For easy reference, the sample is on a perforated page so you can tear it out and keep it handy as you read through the directions. Also, near the back of the booklet is a "master copy" on a perforated page you can tear out to make copies of the MONTHLY INVENTORY RECORD for your recordkeeping.

Use the sample "MONTHLY INVENTORY RECORD" from the last two pages of the booklet to see where you put the information from letters "N" through "Z" in the following directions.

- N** Fill in the identifying information at the top of the MONTHLY INVENTORY RECORD.

If this is the very first day of your inventory recordkeeping, convert the "END STICK INCHES" from the DAILY WORKSHEET into gallons and enter on the MONTHLY RECORD under "END STICK INVENTORY (GALLONS)" for that starting date. (If necessary, see page 9 on converting inches into gallons.) This is all you can do today. Starting tomorrow, follow all of the instructions listed below.

- O** Find the line in the left column on the MONTHLY RECORD with today's date listed. Copy the previous day's "END STICK INVENTORY (GALLONS)" number into the box for today's "START STICK INVENTORY (GALLONS)."
- P** Enter the amount of fuel delivered from the DAILY INVENTORY WORKSHEET. If you were NOT pumping fuel during the time when the delivery was taking place, then use the "GALLONS DELIVERED (STICK)" number. However, if you had to pump fuel while the delivery was taking place, then use the "GROSS GALLONS DELIVERED (RECEIPT)" number as your delivery amount.
- Q** Copy the "AMOUNT PUMPED TODAY" number from the DAILY INVENTORY WORKSHEET into the "GALLONS PUMPED" column of the MONTHLY INVENTORY RECORD.

- R** Add the "START STICK INVENTORY (GALLONS)" and the "GALLONS DELIVERED" columns; then subtract the "GALLONS PUMPED" column. Enter the result in the column labeled "BOOK INVENTORY (GALLONS)."
- S** Copy the "END STICK INCHES" number from the DAILY WORKSHEET into the column labeled "END STICK INVENTORY (INCHES)" on the MONTHLY RECORD. Convert inches into gallons and enter the result in the column on the MONTHLY RECORD labeled "END STICK INVENTORY (GALLONS)." (If necessary, see page 9 on converting inches into gallons.)
- T** Subtract the "BOOK INVENTORY (GALLONS)" from the "END STICK INVENTORY (GALLONS)." Enter the difference into today's "DAILY OVER OR SHORT" box. This number will usually be a positive or negative number (only rarely will it be zero).
- U** Enter your initials to show who entered today's information.

GOOD ADVICE: *If you are "over" for 5 days in a row (or "under" for 5 days in a row), you should check for problems with your math and your UST.*

At least once each month, you must also measure for water in the tank. Smear water-finding paste on the bottom few inches of the gauge stick. Open the fill pipe and **slowly** lower the stick to the tank's bottom. Hold the stick on the bottom for 10 seconds for gasoline (30 seconds for diesel). Then remove the stick. If there is water in the bottom of the tank, the water-finding paste will change color. Read the depth of water indicated by the line where the water-finding paste has changed color to the closest **c** inch division on the stick. **Do not use this stick reading to measure the amount of fuel in the tank**, because the fuel will creep up the stick and will give you an inaccurate reading.

- V** If you checked the tank for water today, enter the number of inches of water in the tank on the line under "Facility Name" at the top of the monthly record. If there is no water present, enter a zero to indicate that you in fact checked for water but found none. If you find more than 1 inch of water, you should arrange for its immediate removal, notify the product supplier, and conduct further tests to ensure that the tank is not leaking.





Step 5—Calculate Monthly Changes In Inventory

At the end of each month, follow the directions below to see if the difference between "stick" and "book" inventory indicates a possible leak.

- W Add all of the month's "GALLONS PUMPED" numbers and write this total at the bottom of the column in the box labeled "TOTAL GALLONS PUMPED."
- X Add all the month's "DAILY OVER OR SHORT" numbers: pay careful attention to positive and negative numbers to get an accurate total. For example, adding +4 and +3 and -2 should equal +5. Enter the total at the bottom of the column in the box labeled "TOTAL GALLONS OVER OR SHORT."
- Y Fill out the "LEAK CHECK" line at the bottom of the MONTHLY INVENTORY RECORD as follows:

! Take the "TOTAL GALLONS PUMPED" number and drop the last two digits to get 1% (for example: 6594 becomes 65).

! Add 130 (for example: $65 + 130 = 195$).

Enter the result of this calculation at the end of the "LEAK CHECK" line. This number is the **maximum change in inventory allowed** by federal regulations (1% of throughput plus 130 gallons).

- Z At the bottom of the MONTHLY INVENTORY RECORD, circle "YES" or "NO" to show whether your "TOTAL GALLONS OVER OR SHORT" number is **LARGER** than the "LEAK CHECK" number you identified in the previous item. Even if your "TOTAL GALLONS OVER OR SHORT" is a negative number, treat it as a positive number for the purpose of this comparison. For example, -74 would become +74.

If you circle "YES" for 2 months in a row, you must notify your regulatory agency as soon as possible (usually within 24 hours) that your tank may be leaking.

NOTE: Keep your inventory control records on file for at least 1 year. Your state, however, may have different rules about when you have to report a leak or how long you must keep the inventory records. Be sure you know the rules that apply to you.

DAILY INVENTORY WORKSHEET

FACILITY NAME: _____

YOUR NAME: _____

DATE: _____

TANK IDENTIFICATION					
Type of Fuel					
Tank Size in Gallons					
END STICK INCHES					
AMOUNT PUMPED	↓	↓	↓	↓	↓
Totalizer Reading					
Totalizer Reading					
Totalizer Reading					
Totalizer Reading					
Totalizer Reading					
Totalizer Reading					
Totalizer Reading					
Totalizer Reading					
TODAY'S SUM OF TOTALIZERS					
Previous Day's Sum of Totalizers					
AMOUNT PUMPED TODAY					
DELIVERY RECORD	↓	↓	↓	↓	↓
Inches of Fuel Before Delivery					
Gallons of Fuel Before Delivery <small>(from tank chart)</small>					
Inches of Fuel After Delivery					
Gallons of Fuel After Delivery <small>(from tank chart)</small>					
GALLONS DELIVERED (STICK) <small>[Gallons "After" - Gallons "Before"]</small>					
GROSS GALLONS DELIVERED (RECEIPT)					

MONTHLY INVENTORY RECORD

TANK IDENTIFICATION & TYPE OF FUEL: _____

MONTH/YEAR: ____ / ____

FACILITY NAME: _____

DATE OF WATER CHECK: _____ LEVEL OF WATER (INCHES): _____

DATE	START STICK INVENTORY (GALLONS)	GALLONS DELIVERED	GALLONS PUMPED	BOOK INVENTORY (GALLONS)	END STICK INVENTORY		DAILY OVER (+) OR SHORT () ["End" "Book"]	INITIALS
					(INCHES)	(GALLONS)		
1	(+)	()	(=)					
2	(+)	()	(=)					
3	(+)	()	(=)					
4	(+)	()	(=)					
5	(+)	()	(=)					
6	(+)	()	(=)					
7	(+)	()	(=)					
8	(+)	()	(=)					
9	(+)	()	(=)					
10	(+)	()	(=)					
11	(+)	()	(=)					
12	(+)	()	(=)					
13	(+)	()	(=)					
14	(+)	()	(=)					
15	(+)	()	(=)					
16	(+)	()	(=)					
17	(+)	()	(=)					
18	(+)	()	(=)					
19	(+)	()	(=)					
20	(+)	()	(=)					
21	(+)	()	(=)					
22	(+)	()	(=)					
23	(+)	()	(=)					
24	(+)	()	(=)					
25	(+)	()	(=)					
26	(+)	()	(=)					
27	(+)	()	(=)					
28	(+)	()	(=)					
29	(+)	()	(=)					
30	(+)	()	(=)					
31	(+)	()	(=)					

TOTAL GALLONS PUMPED > TOTAL GALLONS OVER OR SHORT >

DROP THE LAST 2 DIGITS from the TOTAL GALLONS PUMPED number and enter on the line below

LEAK CHECK: _____ + 130 = _____ gallons

Compare these numbers

Is "TOTAL GALLONS OVER OR SHORT" LARGER than "LEAK CHECK" result? YES NO (circle one)

If answer is "YES" for 2 MONTHS IN A ROW, notify regulatory agency as soon as possible.

KEEP THIS PIECE OF PAPER ON FILE FOR AT LEAST 1 YEAR

SAMPLE

DAILY INVENTORY WORKSHEET

A FACILITY NAME: LAST CHANCE #2
 YOUR NAME: JUAN DOE
 DATE: 9/22/93

B	TANK IDENTIFICATION	1	2	3	4	
	Type of Fuel	REG UNL	PREM UNL	DIESEL	MID UNL	
	Tank Size in Gallons	6000	6000	6000	10,000	
C	END STICK INCHES	41 1/4	58 7/8	69	86 1/2	
D	AMOUNT PUMPED	↓	↓	↓	↓	↓
	Totalizer Reading	24383	30798	92485	44013	
	Totalizer Reading	55138	11017	70178	38974	
	Totalizer Reading					
	Totalizer Reading					
	Totalizer Reading					
	Totalizer Reading					
	Totalizer Reading					
	Totalizer Reading					
E	TODAY'S SUM OF TOTALIZERS	79521	41815	162663	82987	
F	Previous Day's Sum of Totalizers	78271	40260	161663	82584	
G H	AMOUNT PUMPED TODAY	1250	1555	1000	403	
	DELIVERY RECORD	↓	↓	↓	↓	↓
I	Inches of Fuel Before Delivery	13 3/8			49 7/8	
K	Gallons of Fuel Before Delivery (from tank chart)	537			5246	
J	Inches of Fuel After Delivery	41 1/4			86 1/2	
K	Gallons of Fuel After Delivery (from tank chart)	2672			9423	
L	GALLONS DELIVERED (STICK) (Gallons "After" - Gallons "Before")	2135			4177	
M	GROSS GALLONS DELIVERED (RECEIPT)	2100			4200	

SAMPLE

MONTHLY INVENTORY RECORD

N TANK IDENTIFICATION & TYPE OF FUEL: 4 MIDGRADE UNL

MONTH/YEAR: 9, 93

FACILITY NAME: LAST CHANCE #2

DATE OF WATER CHECK: 9/1 LEVEL OF WATER (INCHES): 0 **V**

DATE	START STICK INVENTORY (GALLONS)	GALLONS DELIVERED	GALLONS PUMPED	BOOK INVENTORY (GALLONS)	END STICK INVENTORY		DAILY OVER (+) OR SHORT (-) ("End" - "Book")	INITIALS
					(INCHES)	(GALLONS)		
1	4047 (+)	—	(-) 333 (=)	3714	38 1/4	3690	-24	JD
2	3690 (+)	—	(-) 44 (=)	3646	38	3658	+12	JD
3	3658 (+)	—	(-) 329 (=)	3329	35 3/8	3323	-6	JD
4	3323 (+)	—	(-) 60 (=)	3263	35	3275	+12	JD
5	3275 (+)	—	(-) 145 (=)	3130	33 3/4	3117	-13	JD
6	3117 (+)	—	(-) 238 (=)	2879	31 1/8	2790	-89	JD
7	2790 (+)	6134 (-)	117 (=)	8807	80	8844	+37	JD
8	8844 (+)	—	(-) 127 (=)	8717	78 7/8	8732	+15	JD
9	8732 (+)	—	(-) 182 (=)	8550	77 1/2	8591	+41	JD
10	8591 (+)	—	(-) 205 (=)	8386	75 1/2	8379	-7	JD
11	8379 (+)	—	(-) 204 (=)	8175	73 5/8	8173	-2	JD
12	8173 (+)	—	(-) 166 (=)	8007	72	7991	-16	JD
13	7991 (+)	—	(-) 320 (=)	7671	69 3/4	7730	+159	JD
14	7730 (+)	—	(-) 307 (=)	7423	67	7402	-21	JD
15	7402 (+)	—	(-) 76 (=)	7326	66 1/2	7342	+16	JD
16	7342 (+)	—	(-) 224 (=)	7118	64 1/8	7050	-68	JD
17	7050 (+)	—	(-) 390 (=)	6660	61	6657	-3	JD
18	6657 (+)	—	(-) 296 (=)	6361	58 5/8	6354	-7	JD
19	6354 (+)	—	(-) 78 (=)	6276	58 1/8	6290	+14	JD
20	6290 (+)	—	(-) 424 (=)	5866	54 5/8	5869	+3	JD
21	5869 (+)	—	(-) 205 (=)	5664	53 1/8	5639	-25	JD
22	5639 (+)	4177 (-)	403 (=)	9413	86 1/2	9423	+10	JD
23	9423 (+)	—	(-) 87 (=)	9336	85 1/2	9343	+7	JD
24	9343 (+)	—	(-) 311 (=)	9032	82	9036	+4	JD
25	9036 (+)	—	(-) 239 (=)	8797	79 1/8	8757	-40	JD
26	8757 (+)	—	(-) 256 (=)	8501	76 7/8	8526	+25	JD
27	8526 (+)	—	(-) 264 (=)	8262	74 1/2	8270	+8	JD
28	8270 (+)	—	(-) 263 (=)	8007	72	7991	-16	JD
29	7991 (+)	—	(-) 185 (=)	7806	69	7811	+5	JD
30	7811 (+)	—	(-) 116 (=)	7695	68	7690	-5	JD
31	(+)	(-)	(=)					

W TOTAL GALLONS PUMPED > 6594 TOTAL GALLONS OVER OR SHORT > -74 **X**

DROP THE LAST 2 DIGITS from the PUMPED number and enter on the line below

Y LEAK CHECK: 65 + 130 = 195 gallons

Is "TOTAL GALLONS OVER OR SHORT" LARGER than "LEAK CHECK" result? YES **NO** (circle one) **Z**

If answer is "YES" for 2 MONTHS IN A ROW, notify regulatory agency as soon as possible.

KEEP THIS PIECE OF PAPER ON FILE FOR AT LEAST 1 YEAR

**>>>Copy and post this reminder where employees
who measure tanks can see it!<<<**

GET GOOD INVENTORY CONTROL MEASUREMENTS!

- ! Measure each tank every operating day**
- ! Use gauge sticks that are**
 - ✓ marked to the C inch**
 - ✓ not cut off or worn off at the "0" end**
 - ✓ varnished and not warped**
- ! Measure through the same drop tube each time**
- ! Use good sticking practices**
 - ✓ SLOWLY lower stick**
 - ✓ GENTLY touch stick on tank bottom**
 - ✓ QUICKLY pull stick out**
- ! Measure just before each delivery**
- ! Wait at least 5 minutes after delivery,
then measure again**
- ! Read and record totalizer meters carefully**
- ! Check for water at least once a month
using water-finding paste**

Developed in cooperation with...

Fiberglass

Petroleum Tank & Pipe Institute



INTERNATIONAL ASSOCIATION OF TANK TESTING PROFESSIONALS



SOCIETY OF INDEPENDENT
GASOLINE MARKETERS
OF AMERICA



ATTACHMENT J

Release Detection Maintenance

Release Detection

The release detection system to be used at the facility is a Veeder Root TLS-450 Plus. The system will have inventory probes installed in the tank, sump sensors installed in the submersible sump containment area to monitor sub pump, sump sensors installed in the dispenser sumps and tank interstitial sensors. The system will be installed by a Veeder Root certified technician. The system will be installed in accordance with Veeder Root specifications and instructions. The system is UL listed and is third party certified for release detection under USEPA guidelines. The system has self- diagnostic programs to test and warn of failures of the external devices as well as internal electronics. The system has been tested by a Third Party and found to be compliant with USEPA requirements for release detection.

Ongoing maintenance will be conducted by Texas Fuel Solutions, LLC personnel.

Console Description

The TLS-450PLUS Automatic Tank Gauge (ATG) is a powerful tool that allows fueling operations to run at peak efficiency, with an easy to understand navigation, streamlined inventory and compliance reporting, and powerful business analytics. It can monitor up to 64 tanks, or 32 tanks with BIR. Frequent releases of operating software for the TLS-450PLUS tank gauge assures that data is secure and software features are routinely updated and enhanced.

TLS-450PLUS Consoles, Standard Hardware & Software
Part # & Description

- 860091-301 TLS-450PLUS Console with 8" WVGA Color Touch Screen Display, Printer, 3 Ethernet and Dual USB/Expansion, Dual RS-232, UL/cUL
- 860091-302 TLS-450PLUS Console with 8" WVGA Color Touch Screen Display, Printer, 3 Ethernet and Dual USB/Expansion, Dual RS-232/RS-485, UL/cUL
- 860091-401 TLS-450PLUS Console with 8" WVGA Color Touch Screen Display, No Printer, 3 Ethernet and Dual USB/Expansion, Dual RS-232, UL/cUL
- 860091-402 TLS-450PLUS Console with 8" WVGA Color Touch Screen Display, No Printer, 3 Ethernet and Dual USB/Expansion, Dual RS-232/RS-485, UL/cUL
- 860091-001 TLS-450PLUS Console, No Display, No Printer, 3 Ethernet and Dual USB/Expansion, Dual RS-232, UL/cUL
- 860091-002 TLS-450PLUS Console, No Display, No Printer, 3 Ethernet and Dual USB/Expansion, Dual RS-232/RS-485, UL/cUL

Standard Hardware & Application Software

Software – 333545-001 Application Software (must be ordered with Console) includes Web-enabled, Custom Alarm, On-Console Help, Extended Storage, TLS-Expansion, Static Leak Detection, 3GPH DPLLD

Hardware – 3 Port Ethernet Module (Comm Slot 4), 2-Port USB Module (Comm Slot 5), 3 module compartments

Devices

Module Compatibility	Inputs per Module	iButton Req'd?	Console Slots				TLS-XB 1 Slots				TLS-XB 2 Slots				TLS-XB 3 Slots				Modules per System
			1	2	3	4	1	2	3	4	1	2	3	4	1	2	3	4	
TLS-450PLUS System																			
USM	16	POWER MODULES	●	●	●	●	●	●	●	●	●	●	●	●	●	●	●	●	16
UIOM	14 ¹		●	●	●	●	●	●	●	●	●	●	●	●	●	●	●	●	16
10-Amp Relay	6					●				●				●				●	4
MDIM	12		●	●	●	●	●												5
LVDIM	12		●	●	●	●	●												5

¹=(14) total inputs include (5) AC Inputs, (5) Relay Contacts, (4) 12VDC Inputs

Communications
TLS-450PLUS Device & Communications Module Compatibility

Module	COMMUNICATION MODULES	Console					Modules per System	Type			
		1 ⁴	2	3	4	5					
		P1	P2	P1	P2	P1	P2	P1	P2		
TLS-450PLUS											
RS-232			●		●	●				3	Hardware
Dual RS-232		●	●	●	●					3	Hardware
RS-485			●		●	●				3	Hardware
Dual RS-485 ⁴		●	●	●	●					3	Hardware
RS-232/RS-485 ⁴		●	●	●	●					3	Hardware
Internal Modem			●		●	●				3	Hardware
CDIM		●		●						2	Hardware
EDIM ²		●	●	●	●	●				3	Software
IFSF LON ³		●	●	●	●					1	Hardware

¹=When placed in Slot 3, only Position 2 will be functional

²=EDIM can be programmed in any position with an RS-232 port - up to 3 per system

³=Can be combined with EDIM

⁴=Console ships standard with dual RS-232 or dual RS-232/RS-485 card in Slot 1

TLS-450PLUS Device Modules	Part # & Description		Maximum # of Modules per Console	# of Inputs per Module	Availability
	Universal Sensor Module (USM) Interface for all Probes, Sensors, and DPLLD	332812-001 – Factory Installed Module 330020-619 – Spare Part Module	Up to 4 for each TLS-450PLUS and/or TLS-XB or a maximum of 16 modules per system	16	Sold Separately (either Factory Installed or as a Spare Part Module)
	Universal Input/Output Interface Module (UIOM) for Relay Control and Input Signal Monitoring	332813-001 – Factory Installed Module 330020-620 – Spare Part Module	Up to 4 for each TLS-450PLUS and/or TLS-XB or a maximum of 16 modules per system	5 dry contact output relays / 4 low voltage dry contact inputs / 5 high voltage inputs (<=240 VAC)	
	10-Amp Relay Module has 6 high power outputs / 6 low voltage inputs / must be installed in slot 4 of TLS-450 PLUS and TLS-XB	333564-001 – Factory Installed Module 330020-814 – Spare Part Module	Up to 1 for each TLS-450PLUS and/or TLS-XB or a maximum of 4 modules per system – <i>*Only installed in slot 4</i>	4	
	BIR/AccuChart LVDIM for TLS-450PLUS, 12 Inputs	333581-001 – Factory Installed Module 330020-800 – Spare Part Module			
	BIR/AccuChart MDIM for TLS-450PLUS, 12 Inputs	333582-001 – Factory Installed Module 330020-799 – Spare Part Module			
TLS-450PLUS Communications Modules	Part # & Description		Maximum # of Modules per System	Availability	
	SiteFax™ Interface Module (Comm. Slots 1,2,3), for TLS-450PLUS	332818-001 – Factory Installed Module 330020-612 – Spare Part Module	Up to 3 per System	Sold Separately (either Factory Installed or as a Spare Part Module) For Spare Part "upgrade" kits, the BIR/AccuChart Feature Enhancement will be shipped on a Veeder-Root iButton adapter – P/N 330020-659	
	Single RS-232 Interface Module (Comm. Slots 1,2,3), for TLS-450PLUS	332866-001 – Factory Installed Module 330020-613 – Spare Part Module			
	RS-232 Dual Interface Module (Comm. Slots 1,2,3), for TLS-450PLUS	332868-001 – Factory Installed Module 330020-617 – Spare Part Module			
	Single RS-232/RS-485 Dual Interface Module (Comm. Slots 1,2,3), for TLS-450PLUS	332870-001 – Factory Installed Module 330020-618 – Spare Part Module			
	BIR/AccuChart EDIM for TLS-450PLUS	333149-001 – Factory Installed Module 330020-801 – Spare Part Module	1 per System		
	BIR/AccuChart CDIM for TLS-450PLUS, 3 Inputs	333580-001 – Factory Installed Module 330020-802 – Spare Part Module			
	IFSF LON Interface Module (Comm. Slots 1,2,3), for TLS-450PLUS	333659-001 – Factory Installed Module 330020-828 – Spare Part Module			
TLS-450PLUS Optional Software	Part # & Description				
	Continuous Statistical Leak Detection (CSLD) for TLS-450PLUS			332972-006	
	Ultimate Testing: Digital Line Leak Detection for TLS-450PLUS			332972-007	
	Risk Management: Digital Line Leak Detection for TLS-450PLUS			332972-008	
	Base Compliance: Digital Line Leak Detection for TLS-450PLUS			332972-009	
	Timed Sudden Loss Detection for TLS-450PLUS			332972-018	
	Vapor Collection Monitor for TLS-450PLUS			332972-021	
	DEF Recirculation Software Feature for TLS-450PLUS & DEF Temperature Sensor Installation Kit			332972-026 – Software 794380-210 – Install Kit	

Specifications	
Operating Temperature	+32 to +104°F (0 to +40°C)
Storage Temperature	-40 to +158°F (-40 to +70°C)
Installation Location	NEMA 4 or indoors
Relative Humidity	0-90% (non-condensing)
External Dimensions	18.4" x 11" x 8.8" (46.74cm x 27.94cm x 22.35cm)
Construction	16GA (0.060 in/0.1524 cm) powder coated steel
Console Power Wiring Requirements	AC Power Wiring – Wires carrying 120 or 240 VAC from power panel to the console should be #14 AWG (or larger) wire for line, neutral & chassis ground (3) ; and 4 sq. mm, rated for at least 90C for barrier ground.
Probe & Sensor to Console Wiring Requirements	<ol style="list-style-type: none"> 1. Wire Type – Shielded cable required regardless of conduit material or application. It must be rated less than 100 picofarad per ft manufactured with a suitable material such as Carol C2534 or Belden 88760, 8760, or 8770. 2. Wire Length – Maximum 1,000ft (304.8m) to meet intrinsic safety requirements. Improper system operation could result for runs over 1,000ft (304.8m). 3. Wire Gauges – Color coded – shielded cable used in all installations. Wires should be #14 - #18 AWG stranded copper wire and installed as Class 2 circuits. As an alternate method when approved by the local authority having jurisdiction, #22 AWG wire such as 88761 may be suitable with the following requirements: Wire run is less than 750ft (228.6m), Capacitance does not exceed 100 pF/ft; Inductance does not exceed 0.2 uH/ft.
System Power Requirements	AC Input – Universal AC power supply: 100 to 249 VAC, 50/60Hz, 2A max.
Display Specifications	8" (20.32cm) Color WVGA LCD touch screen display
Connectivity Methods	Ethernet, Web Browser, Modem, Fax, Serial
Data Storage Features	SD card
Software Security Features	Centralized Device Management to protect your network of TLS-4XX consoles
Custom User Access	Front Panel Display control through user specific log-in; User defined roles to restrict access / functionality. Screen permissions can be limited to view, edit, perform
System Security	<ol style="list-style-type: none"> 1. Partitioned Ethernet Ports that can be used to separate user network from the internet 2. Port availability control: SSH Port (22), HTTPS Port (443), Serial Command Port (10001) 3. Reassign Port Numbers (i.e., HTTPS on 50443) 4. System Integrator CVE Scans & Fixes 5. Periodic System Updates to protect against persistent threats
Customized Alarm Features	Customizable for all alarms
Approvals	UL cUL, ATEX, IECEx, NEPSI, FCC, FMC, PESO, ANZEx, ULC, INMETRO, IQC, EAC, NWGLDE, and CEN
Third Party Evaluations	http://www.nwglde.org/evals/veeder_root_zf.html
Product Installation Guide	https://www.veeder.com/us/technical-document-library

System Compatibilities Guide

Feature/Console	TLS-450PLUS
CONSOLE DESIGN	
Modular/Expandable Features	•
LCD with Touch Screen (optional)	8" WVGA Color
Integral Roll Printer	Optional
Universal Power Supply	•
INVENTORY CONTROL	
Graphical Inventory Status	•
Complete Inventory Reports	•
Programmable Auto Report Times	•
Inventory Increase Report	•
Timed Sudden Loss Detection	Optional
BUSINESS INVENTORY RECONCILIATION	
Shift-Based Reconciliation	Optional
Reconciliation by Tank	Optional
TANK CALIBRATION	
Multi-Pass Tank Calibration	Optional
Single-Pass / Metered Drop	Optional
Limited Range Calibration	Optional
Supports Multiple Tank Charts per Tank	Optional
Supports Multiple Line Manifold Tanks	Optional
Graphical / Text Calibration Diagnostics	Optional
Automatic and Manual Meter Mapping	Optional
IN-TANK LEAK TEST	
0.1 GPH Tank Tightness Testing	•
0.2 GPH Tank Tightness Testing	•
Continuous Statistical Leak Detection	Optional
Selectable Test Rates	•
Programmable Automatic Test Schedules	•
PASS, FAIL, or INVALID Indicators	•
LINE LEAK DETECTION	
Integral Line Leak Detector	Optional
Programmable Line Test Features	Optional
INTERSTITIAL/SUMP LEAK SENSING	
Tank Annulus	•
Sump	•
Dispenser Pan	•
Mag Sump	•
Sensor Location Identifiers	•
VAPOR WELL MONITORING	
Hydrocarbon Vapor Detection	•
High Water Level Alarm	•
GROUNDWATER MONITORING	
Hydrocarbon Liquid Detection	•
Low Water Alarm	•
AIR VAPOR MONITORING	
Vapor Collection Monitor	Optional
ALARMS	
Leak	•
Overflow	•
High Level	•
Sudden Loss	•
High Water	•
Low Inventory	•
Programmable Alarm Limits	•

Feature/Console	TLS-450PLUS	TLS-450PLUS with TLS-XB**
DATA COMMUNICATIONS		
RS-232	5	5
RS-485	3	3
Fax Transmittal (SiteFax)	Optional	Optional
External USB 2.0	2	2
Ethernet Ports	3	3
International Forecourt Standards Forum (IFSF)	1	1
SYSTEM CAPABILITIES		
Manifold Tank Capability (Line & Siphon)	•	•
Height-Based Pump Priority Control for Manifoldded Tanks	•	•
Pump Alternate on the Fly	•	•
Self-Diagnostics	•	•
Emergency Generator Capability	•	•
Up to 3 Years Data Storage	•	•
FAX Notification On-Time or Event	Optional	Optional
Email Notification On-Time or Event	•	•
LCD with Touch Screen	Optional	Optional
On-Board Help	•	•
Custom Help	•	•
Custom Alarms	•	•
Environmental Reports (Compliance Reports Summary)	•	•
Sensor Reports	•	•
Sensor History Report by Period, Month, Week or Custom	•	•
Web-Enabled	•	•
System Duplicate	•	•
SYSTEM CAPACITIES*		
Inputs	64	256
In-Tank Probes (Including Density)	64	64
In-Tank Probes with BIR	32	32
Digital Pressurized Line Leak Detectors (Additional Software Req'd)	15	16
2-WIRE SENSORS		
Magnetostrictive Discriminating Level Indicating Sump Sensor	64	99
Discriminating Dispenser Pan & Containment Sensors	64	99
Solid-State Non-Discr. Dispenser Pan & Containment Sensors	64	99
Sump Sensors	64	99
Position Sensitive Pan/Sump Sensor	64	99
Interstitial Sensor for Fiberglass Tanks	64	99
Solid-State Discr. Interstitial Sensors for Fiberglass Tanks	64	99
Alt. Ethanol Fluid Interstitial Sensors for Fiberglass Tanks	64	99
Interstitial Sensors for Steel Tanks	64	99
Microsensors	64	99
Position Sensitive Interstitial Sensor for Steel Tanks	64	99
Alt. Ethanol Fluid Solid-State Interstitial Sensor for Steel Tanks	64	99
Hydrostatic Sensors for Brine-Filled Double-Wall Tanks	64	99
Hydrostatic Sensor for Brine-Filled Double-Wall Sumps	64	99
Oil Water Separator Sensor	64	99
3-WIRE SENSORS		
Solid-State Discr. Dispenser Pan & Containment Sump Sensors	32	99
Groundwater Sensor	32	99
Vapor Sensor for Monitoring Wells	32	99
INPUT & OUTPUT		
Output Relays	21	32
External Inputs Low Voltage	16	64
External Inputs High Voltage	20	32
10-amp Relay	4	16

* Indicates the maximum number of devices the system can handle if all slots/ positions are filled with that type of device.

** TLS-450PLUS with (3) three TLS-XB boxes

Notice

Veeder-Root makes no warranty of any kind with regard to this publication, including, but not limited to, the implied warranties of merchantability and fitness for a particular purpose.

Veeder-Root shall not be liable for errors contained herein or for incidental or consequential damages in connection with the furnishing, performance, or use of this publication.

Veeder-Root reserves the right to change system options or features, or the information contained in this publication.

This publication contains proprietary information which is protected by copyright. All rights reserved. No part of this publication may be photocopied, reproduced, or translated to another language without the prior written consent of Veeder-Root.

Example Illustrations

Illustrations used in this guide for example sensor installations may contain components that are customer supplied and not included with the sensor. Please check with your Veeder-Root Distributor for recommended installation accessories.

Third Party Evaluations

Third party evaluations of the Veeder-Root sensors contained in this application guide can be found under the Veeder-Root vendor name on the National Work Group on Leak Detection Evaluations (NWGLDE) website:

<http://www.nwglde.org>

Temporary Stormwater Section
TCEQ-0602

Temporary Stormwater Section

Texas Commission on Environmental Quality

for Regulated Activities on the Edwards Aquifer Recharge Zone and Relating to 30 TAC §213.5(b)(4)(A), (B), (D)(I) and (G); Effective June 1, 1999

To ensure that the application is administratively complete, confirm that all fields in the form are complete, verify that all requested information is provided, consistently reference the same site and contact person in all forms in the application, and ensure forms are signed by the appropriate party.

Note: Including all the information requested in the form and attachments contributes to more streamlined technical reviews.

Signature

To the best of my knowledge, the responses to this form accurately reflect all information requested concerning the proposed regulated activities and methods to protect the Edwards Aquifer. This **Temporary Stormwater Section** is hereby submitted for TCEQ review and executive director approval. The application was prepared by:

Print Name of Customer/Agent: NICK SANDLIN, P.E. (SANDLIN SERVICES, LLC)

Date: 4/20/2023

Signature of Customer/Agent:

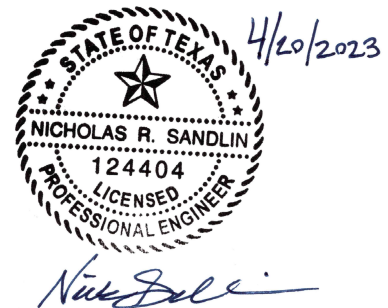

Regulated Entity Name: BELL BLVD C-STORE

Project Information

Potential Sources of Contamination

Examples: Fuel storage and use, chemical storage and use, use of asphaltic products, construction vehicles tracking onto public roads, and existing solid waste.

1. Fuels for construction equipment and hazardous substances which will be used during construction:

The following fuels and/or hazardous substances will be stored on the site: _____

These fuels and/or hazardous substances will be stored in:

- Aboveground storage tanks with a cumulative storage capacity of less than 250 gallons will be stored on the site for less than one (1) year.

- Aboveground storage tanks with a cumulative storage capacity between 250 gallons and 499 gallons will be stored on the site for less than one (1) year.
- Aboveground storage tanks with a cumulative storage capacity of 500 gallons or more will be stored on the site. An Aboveground Storage Tank Facility Plan application must be submitted to the appropriate regional office of the TCEQ prior to moving the tanks onto the project.
- Fuels and hazardous substances will not be stored on the site.
- 2. **Attachment A - Spill Response Actions.** A site specific description of the measures to be taken to contain any spill of hydrocarbons or hazardous substances is attached.
- 3. Temporary aboveground storage tank systems of 250 gallons or more cumulative storage capacity must be located a minimum horizontal distance of 150 feet from any domestic, industrial, irrigation, or public water supply well, or other sensitive feature.
- 4. **Attachment B - Potential Sources of Contamination.** A description of any activities or processes which may be a potential source of contamination affecting surface water quality is attached.

Sequence of Construction

- 5. **Attachment C - Sequence of Major Activities.** A description of the sequence of major activities which will disturb soils for major portions of the site (grubbing, excavation, grading, utilities, and infrastructure installation) is attached.
 - For each activity described, an estimate (in acres) of the total area of the site to be disturbed by each activity is given.
 - For each activity described, include a description of appropriate temporary control measures and the general timing (or sequence) during the construction process that the measures will be implemented.
- 6. Name the receiving water(s) at or near the site which will be disturbed or which will receive discharges from disturbed areas of the project: TURKEY CREEK-BRUSHY CREEK

Temporary Best Management Practices (TBMPs)

Erosion control examples: tree protection, interceptor swales, level spreaders, outlet stabilization, blankets or matting, mulch, and sod. Sediment control examples: stabilized construction exit, silt fence, filter dikes, rock berms, buffer strips, sediment traps, and sediment basins. Please refer to the Technical Guidance Manual for guidelines and specifications. All structural BMPs must be shown on the site plan.

- 7. **Attachment D – Temporary Best Management Practices and Measures.** TBMPs and measures will prevent pollution of surface water, groundwater, and stormwater. The construction-phase BMPs for erosion and sediment controls have been designed to retain sediment on site to the extent practicable. The following information is attached:

- A description of how BMPs and measures will prevent pollution of surface water, groundwater or stormwater that originates upgradient from the site and flows across the site.
 - A description of how BMPs and measures will prevent pollution of surface water or groundwater that originates on-site or flows off site, including pollution caused by contaminated stormwater runoff from the site.
 - A description of how BMPs and measures will prevent pollutants from entering surface streams, sensitive features, or the aquifer.
 - A description of how, to the maximum extent practicable, BMPs and measures will maintain flow to naturally-occurring sensitive features identified in either the geologic assessment, TCEQ inspections, or during excavation, blasting, or construction.
8. The temporary sealing of a naturally-occurring sensitive feature which accepts recharge to the Edwards Aquifer as a temporary pollution abatement measure during active construction should be avoided.
- Attachment E - Request to Temporarily Seal a Feature.** A request to temporarily seal a feature is attached. The request includes justification as to why no reasonable and practicable alternative exists for each feature.
 - There will be no temporary sealing of naturally-occurring sensitive features on the site.
9. **Attachment F - Structural Practices.** A description of the structural practices that will be used to divert flows away from exposed soils, to store flows, or to otherwise limit runoff discharge of pollutants from exposed areas of the site is attached. Placement of structural practices in floodplains has been avoided.
10. **Attachment G - Drainage Area Map.** A drainage area map supporting the following requirements is attached:
- For areas that will have more than 10 acres within a common drainage area disturbed at one time, a sediment basin will be provided.
 - For areas that will have more than 10 acres within a common drainage area disturbed at one time, a smaller sediment basin and/or sediment trap(s) will be used.
 - For areas that will have more than 10 acres within a common drainage area disturbed at one time, a sediment basin or other equivalent controls are not attainable, but other TBMPs and measures will be used in combination to protect down slope and side slope boundaries of the construction area.
 - There are no areas greater than 10 acres within a common drainage area that will be disturbed at one time. A smaller sediment basin and/or sediment trap(s) will be used in combination with other erosion and sediment controls within each disturbed drainage area.

- There are no areas greater than 10 acres within a common drainage area that will be disturbed at one time. Erosion and sediment controls other than sediment basins or sediment traps within each disturbed drainage area will be used.
11. **Attachment H - Temporary Sediment Pond(s) Plans and Calculations.** Temporary sediment pond or basin construction plans and design calculations for a proposed temporary BMP or measure have been prepared by or under the direct supervision of a Texas Licensed Professional Engineer. All construction plans and design information must be signed, sealed, and dated by the Texas Licensed Professional Engineer. Construction plans for the proposed temporary BMPs and measures are attached.
- N/A
12. **Attachment I - Inspection and Maintenance for BMPs.** A plan for the inspection of each temporary BMP(s) and measure(s) and for their timely maintenance, repairs, and, if necessary, retrofit is attached. A description of the documentation procedures, recordkeeping practices, and inspection frequency are included in the plan and are specific to the site and/or BMP.
13. All control measures must be properly selected, installed, and maintained in accordance with the manufacturer's specifications and good engineering practices. If periodic inspections by the applicant or the executive director, or other information indicate a control has been used inappropriately, or incorrectly, the applicant must replace or modify the control for site situations.
14. If sediment escapes the construction site, off-site accumulations of sediment must be removed at a frequency sufficient to minimize offsite impacts to water quality (e.g., fugitive sediment in street being washed into surface streams or sensitive features by the next rain).
15. Sediment must be removed from sediment traps or sedimentation ponds not later than when design capacity has been reduced by 50%. A permanent stake will be provided that can indicate when the sediment occupies 50% of the basin volume.
16. Litter, construction debris, and construction chemicals exposed to stormwater shall be prevented from becoming a pollutant source for stormwater discharges (e.g., screening outfalls, picked up daily).

Soil Stabilization Practices

Examples: establishment of temporary vegetation, establishment of permanent vegetation, mulching, geotextiles, sod stabilization, vegetative buffer strips, protection of trees, or preservation of mature vegetation.

17. **Attachment J - Schedule of Interim and Permanent Soil Stabilization Practices.** A schedule of the interim and permanent soil stabilization practices for the site is attached.

18. Records must be kept at the site of the dates when major grading activities occur, the dates when construction activities temporarily or permanently cease on a portion of the site, and the dates when stabilization measures are initiated.
19. Stabilization practices must be initiated as soon as practicable where construction activities have temporarily or permanently ceased.

Administrative Information

20. All structural controls will be inspected and maintained according to the submitted and approved operation and maintenance plan for the project.
21. If any geologic or manmade features, such as caves, faults, sinkholes, etc., are discovered, all regulated activities near the feature will be immediately suspended. The appropriate TCEQ Regional Office shall be immediately notified. Regulated activities must cease and not continue until the TCEQ has reviewed and approved the methods proposed to protect the aquifer from any adverse impacts.
22. Silt fences, diversion berms, and other temporary erosion and sediment controls will be constructed and maintained as appropriate to prevent pollutants from entering sensitive features discovered during construction.



Temporary Stormwater Section (TCEQ-0602)

Attachment A: Spill Response Actions

Spill Response Actions

In the event of an accidental spill, immediate action shall be undertaken by the General Contractor to contain and remove the spilled material. All hazardous materials, including contaminated soil and liquid concrete waste (if applicable), shall be disposed of by the Contractor in the manner specified by Federal, State and Local regulations and by the manufacturer of such products. As soon as possible, the spill shall be reported to the appropriate agencies. As required under the provisions of the Clean Water Act, any spill or discharge entering waters of the United States shall be properly reported. The General Contractor shall prepare a written record of any spill and associated clean-up activities of petroleum products or hazardous materials in excess of 1 gallon or reportable quantities, whichever is less. The General Contractor shall provide notice to the Owner immediately upon identification of a reportable spill.

All spills of petroleum products or hazardous materials in excess of Reportable Quantities as defined by EPA or the State or Local agency regulations, shall be immediately reported within 24 hours to the EPA National Response Center (1-800-424-8802), TCEQ (1-800-832-8224), and local Fire Department (911).

The reportable quantity for hazardous materials can be found in 40 CFR 302:

Reportable Quantities		
Material	Media Released to	Reportable Quantities
Engine Oil, Fuel, Hydraulic & Brake Fluid	Land	25 gallons
Engine Oil, Fuel, Hydraulic & Brake Fluid	Water	Visible sheen
Antifreeze	Land	100 lbs (13 gal.)
Battery Acid	Land, Water	100 lbs
Refrigerant	Air	1 lb
Gasoline	Air, Land, Water	100 lbs
Engine Degreasers	Air, Land, Water	100 lbs

For more information, please visit https://www.tceq.texas.gov/response/spills/spill_rq.html

In order to minimize the potential for a spill of petroleum product or hazardous materials to come in contact with stormwater, the following steps shall be implemented.



**BELL BOULEVARD C-STORE
WATER POLLUTION ABATEMENT PLAN**

- a) All materials with hazardous properties (such as pesticides, petroleum products, fertilizers, detergents, construction chemicals, acids paints, paint solvents, additives for soil stabilization, concrete curing compounds and additives, etc.) shall be stored in a secure location, under cover and in appropriate, tightly sealed containers when not in use.
- b) The minimum practical quantity of all such materials shall be kept on the job site and scheduled for delivery as close to the time of use as practical. Post Material Safety Data Sheets (MSDS), as well as proper storage, cleanup, and spill reporting instructions for hazardous materials stored or used on the project site in an open, conspicuous, and accessible location.
- c) A spill control and containment kit (containing for example: absorbent material such as kitty litter or sawdust, acid neutralizing agent, brooms, dust pans, mops, rags, gloves, goggles, plastic and metal trash containers, etc.) shall be provided on the construction site and construction employees shall be trained in when and how to use spill containment materials.
- d) The contractor personnel will immediately clean up any oil, fuel or hydraulic fluid if observed being released from equipment or vehicles. Vehicles or equipment will cease operation until required repairs are made to the equipment.
- e) All of the product in a container shall be used before the container is disposed of. All such containers shall be triple rinsed with water prior to disposal. The rinse water used in these containers shall be disposed of in a manner in compliance with State and Federal regulations and shall not be allowed to mix with stormwater discharges.
- f) All products shall be stored in and used from the original container with the original product label.
- g) All products shall be used in strict compliance with instructions on the product label.
- h) The disposal of the excess or used products shall be in strict compliance with instructions on the products label.

Spill Prevention and Control

Education

- 1.) Be aware that different materials pollute in different amounts. Make sure that each employee knows what a “significant spill” is for each material they use, and what is the appropriate response for “significant” and “insignificant” spills. Employees should also be aware of when spill must be reported to the TCEQ. Information available in 30 TAC 327.4 and 40 CFR 302.4.
- 2.) Educate employees and subcontractors on potential dangers to humans and the environment from spills and leaks.



***BELL BOULEVARD C-STORE
WATER POLLUTION ABATEMENT PLAN***

- 3.) Hold regular meetings to discuss and reinforce appropriate disposal procedures (incorporate into regular safety meetings).
- 4.) Establish a continuing education program to indoctrinate new employees.
- 5.) Have contractor's superintendent or representative oversee and enforce proper spill prevention and control measures.

General Measures

- 1.) To the extent that the work can be accomplished safely, spills of oil, petroleum products, substances listed under 40 CFR parts 110,117, and 302, and sanitary and septic wastes should be contained and cleaned up immediately.
- 2.) Store hazardous materials and wastes in covered containers and protect from vandalism.
- 3.) Place a stockpile of spill cleanup materials where it will be readily accessible.
- 4.) Train employees in spill prevention and cleanup.
- 5.) Designate responsible individuals to oversee and enforce control measures.
- 6.) Spills should be covered and protected from stormwater runoff during rainfall to the extent that it doesn't compromise cleanup activities.
- 7.) Do not bury or wash spills with water.
- 8.) Store and dispose of used clean up materials, contaminated materials, and recovered spill material that is no longer suitable for the intended purpose in conformance with the provisions in applicable BMPs.
- 9.) Do not allow water used for cleaning and decontamination to enter storm drains or watercourses. Collect and dispose of contaminated water in accordance with applicable regulations.
- 10.) Contain water overflow or minor water spillage and do not allow it to discharge into drainage facilities or watercourses.
- 11.) Place Material Safety Data Sheets (MSDS), as well as proper storage, cleanup, and spill reporting instructions for hazardous materials stored or used on the project site in an open, conspicuous, and accessible location.
- 12.) Keep waste storage areas clean, well-organized, and equipped with ample cleanup supplies as appropriate for the materials being stored. Perimeter controls, containment structures, covers, and liners should be repaired or replaced as needed to maintain proper function.



***BELL BOULEVARD C-STORE
WATER POLLUTION ABATEMENT PLAN***

Cleanup

- 1.) Clean up leaks and spills immediately.
- 2.) Use a rag for small spills on paved surfaces, a damp mop for general cleanup, and absorbent material for larger spills. If the spilled material is hazardous, then the used cleanup materials are also hazardous and must be disposed of as hazardous waste.
- 3.) Never hose down or bury dry material spills. Clean up as much of the material as possible and dispose of properly. See the waste management BMPs in this section for specific information.

Minor Spills

- 1.) Minor spills typically involve small quantities of oil, gasoline, paint, etc. which can be controlled by the first responder at the discovery of the spill.
- 2.) Use absorbent materials on small spills rather than hosing down or burying the spill.
- 3.) Absorbent materials should be promptly removed and disposed of properly.
- 4.) Follow the practice below for a minor spill:
- 5.) Contain the spread of the spill.
- 6.) Recover spilled materials.
- 7.) Clean the contaminated area and properly dispose of contaminated materials.

Semi-Significant Spills

Semi-significant spills still can be controlled by the first responder along with the aid of other personnel such as laborers and the foreman, etc. This response may require the cessation of all other activities. Spills should be cleaned up immediately:

- 1.) Contain spread of the spill.
- 2.) Notify the project foreman immediately.
- 3.) If the spill occurs on paved or impermeable surfaces, clean up using "dry" methods (absorbent materials, cat litter and/or rags). Contain the spill by encircling with absorbent materials and do not let the spill spread widely.
- 4.) If the spill occurs in dirt areas, immediately contain the spill by constructing an earthen dike. Dig up and properly dispose of contaminated soil.
- 5.) If the spill occurs during rain, cover spill with tarps or other material to prevent contaminating runoff.



***BELL BOULEVARD C-STORE
WATER POLLUTION ABATEMENT PLAN***

Significant/Hazardous Spills

For significant or hazardous spills that are in reportable quantities:

- 1.) Notify the TCEQ by telephone as soon as possible and within 24 hours at 512- 339-2929 (Austin) or 210-490-3096 (San Antonio) between 8 AM and 5 PM. After hours, contact the Environmental Release Hotline at 1-800-832-8224. It is the contractor's responsibility to have all emergency phone numbers at the construction site.
- 2.) For spills of federal reportable quantities, in conformance with the requirements in 40 CFR parts 110,119, and 302, the contractor should notify the National Response Center at (800) 424-8802.
- 3.) Notification should first be made by telephone and followed up with a written report.
- 4.) The services of a spills contractor or a Haz-Mat team should be obtained immediately. Construction personnel should not attempt to clean up until the appropriate and qualified staffs have arrived at the job site.
- 5.) Other agencies which may need to be consulted include, but are not limited to, the City Police Department, County Sheriff Office, Fire Departments, etc.

More information on spill rules and appropriate responses is available on the TCEQ website at: http://www.tnrcc.state.tx.us/enforcement/emergency_response.html.

Vehicle and Equipment Maintenance

- 1.) If maintenance must occur onsite, use a designated area and a secondary containment, located away from drainage courses, to prevent the runoff of stormwater and the runoff of spills.
- 2.) Regularly inspect onsite vehicles and equipment for leaks and repair immediately.
- 3.) Check incoming vehicles and equipment (including delivery trucks, and employee and subcontractor vehicles) for leaking oil and fluids. Do not allow leaking vehicles or equipment onsite.
- 4.) Always use secondary containment, such as a drain pan or drop cloth, to catch spills or leaks when removing or changing fluids.
- 5.) Place drip pans or absorbent materials under paving equipment when not in use.
- 6.) Use absorbent materials on small spills rather than hosing down or burying the spill. Remove the absorbent materials promptly and dispose of properly.
- 7.) Promptly transfer used fluids to the proper waste or recycling drums. Don't leave full drip pans or other open containers lying around.



**BELL BOULEVARD C-STORE
WATER POLLUTION ABATEMENT PLAN**

- 8.) Oil filters disposed of in trashcans or dumpsters can leak oil and pollute stormwater. Place the oil filter in a funnel over a waste oil-recycling drum to drain excess oil before disposal. Oil filters can also be recycled. Ask the oil supplier or recycler about recycling oil filters.
- 9.) Store cracked batteries in a non-leaking secondary container. Do this with all cracked batteries even if you think all the acid has drained out. If you drop a battery, treat it as if it is cracked. Put it into the containment area until you are sure it is not leaking.

Vehicle and Equipment Fueling

- 1.) If fueling must occur on site, use designated areas, located away from drainage courses, to prevent the runoff of stormwater and the runoff of spills.
- 2.) Discourage “topping off” of fuel tanks.
- 3.) Always use secondary containment, such as a drain pan, when fueling to catch spills/ leaks.

SPILL REPORT FORM

Notes to General Contractor:

- Control and contain the spill.
- Contact the appropriate regulatory agencies if the spill exceeds the applicable reportable quantity.
- Clean up the spill and dispose of waste according to federal, state and local regulations.
- Complete the Spill Report Form in full for each spill that exceeds the applicable reportable quantity and submit to the Owner.
- Call the Owner.
- Resolve as appropriate and as required by regulatory authorities.



SPILL REPORT FORM

DATE:
PROJECT:
PROJECT ADDRESS:

Spill Reported By: _____

Date / Time of Spill: _____

Describe spill location and events leading to spill: _____

Material Spilled: _____

Source of Spill: _____

Amount Spilled: _____

Amount Spilled to Waterway (Name Waterway): _____

Containment or Clean up Action: _____

Approximate depth (yards) of soil excavation: _____

List injuries or Personal Contamination: _____

Action to be taken to prevent future spills:

Agencies notified of spill:

Contractor Signature and Printed Name

Date

**AFTER NOTIFYING GOVERNING AUTHORITIES, IMMEDIATELY COMPLETE THIS FORM
AND CONTACT THE OWNER IF THE SPILL EXCEEDS THE REPORTABLE QUANTITY FOR
THE GOVERNING AGENCY**



Temporary Stormwater Section (TCEQ-0602)

Attachment B: Potential Sources of Contamination

Potential Sources of Contamination and Preventive Measures:

Potential Source: Concrete and concrete products used on-site during construction.

Preventative Measures: Concrete washout structure will be used if necessary.

Potential Source: Oil, grease, fuel, and hydraulic fluid contamination from construction equipment and vehicle dripping.

Preventative Measures: Vehicle maintenance will be performed at a local maintenance shop.

Potential Source: Miscellaneous trash and litter from construction workers and material wrappings.

Preventative Measures: Trash containers will be placed throughout the site to encourage proper disposal of trash.

Potential Source: Silt leaving the site.

Preventative Measures: Contractor will install all temporary best management practices prior to start of construction including the stabilized construction entrance to prevent tracking onto adjoining streets.

Potential Source: Construction debris

Preventative Measures: Construction debris will be monitored daily by contractor. Debris will be collected weekly and placed in disposal bins. Situations requiring immediate attention will be addressed on a case-by-case basis.

Potential Source: Soil and mud from construction vehicle tires as they leave the site.

Preventative Measures: a stabilized construction exit shall be utilized as vehicles leave the site. And soil, mud, etc. carried from the project onto public roads shall be cleaned up within 24 hours.

Potential Source: Sediment from soil, sand, gravel, and excavated materials stockpiled on site.

Preventative Measures: Silt fence shall be installed on the down gradient side of the stockpiled materials. Reinforced rock berms shall be installed at all downstream discharge locations.

Potential Source: Portable toilet spill

Preventative Measures: Toilets on the site will be emptied on a regular basis by the contracted toilet company.



Temporary Stormwater Section (TCEQ-0602)

Attachment C: Sequence of Major Activities

The installation of erosion and sedimentation controls shall occur prior to any excavation of materials or major disturbances on the site. The sequence of major construction activities will be as follows. Approximate acreage (AC) expected to be disturbed is listed in parentheses next to each activity.

Intended Schedule or Sequence of Major Activities:

1. Submit written notice of construction to TCEQ regional office at least 48 hours prior to the start of any regulated activities. (See Permanent Stormwater Section – Attachment F)
2. A pre-construction conference prior to commencement of construction. All contractors conducting regulated activities associated with this project must be provided with complete copies of the approved Water Pollution Abatement Plan (WPAP) and the TCEQ letter indicating the specific conditions of its approval. During the course of these regulated activities, the contractors are required to keep on-site copies of the approved plan and approval letter.
3. Contractors must follow requirements as outlined in TCEQ General Construction Notes for the Water Pollution Abatement Plan (WPAP). WPAP Construction Notes are included on the Construction Plan sheets (See Permanent Stormwater Section – Attachment F).
4. Prior to beginning any construction activity, all temporary erosion and sedimentation BMPs and control measures must be properly installed and maintained in accordance with the approved plans and manufacturers specifications (0.11 Acres).
5. Evaluate temporary erosion control installation. If inspections indicate a control has been used inappropriately, or incorrectly, the applicant must replace or modify the control for site situations. These controls must remain in place until the disturbed areas have been permanently stabilized.
6. Review construction schedule and the Water Pollution Abatement Plan (WPAP) requirements.
7. Topsoil, Irrigation and Landscaping: Revegetate all disturbed areas according to plan.
8. Site cleanup and removal of temporary erosion/sedimentation BMP controls. (0.11 Acres)

Maximum total construction time is not expected to exceed 9 months.



Temporary Stormwater Section (TCEQ-0602)

Attachment D: Temporary Best Management Practices and Measures

1. There are 0.0 AC of storm water that originate up gradient from the site and flow across the site through an onsite BMP.
2. Temporary BMPs will be installed prior to soil disturbing construction activity. Silt fencing will be placed along the down-gradient sides of the property and limits of construction to prevent silt from escaping the construction area during construction.
3. A concrete washout pit may be used to collect all excess concrete during construction, if needed.
4. Temporary BMPs for this project will protect surface water or groundwater from turbid water, phosphorus, sediment, oil and other contaminants, which may mobilize in stormwater flows by slowing the flow of runoff to allow sediment and suspended solids to settle out of the runoff.
5. Practices may also be implemented on site for interim and permanent stabilization. Stabilization practices may include but are not limited to establishment of temporary vegetation; establishment of permanent vegetation; mulching; geotextiles; sod stabilization; vegetative buffer strips; protection of existing trees and vegetation; and other similar measures.
6. There are no sensitive features or surface streams within the boundaries of the project that would require temporary BMPs. The temporary onsite BMPs will be used to treat stormwater runoff before it leaves the project and prevent pollutants from entering into surface streams or any sensitive features down gradient of the site.



**Temporary Stormwater Section
(TCEQ-0602)**

**Attachment E:
Request to Temporarily Seal a Feature
(NOT APPLICABLE)**



Temporary Stormwater Section (TCEQ-0602)

Attachment F: Structural Practices

Structural BMPs will be used to limit runoff discharge of pollutants from exposed areas of the site. BMPs will be installed prior to soil disturbing construction activity. Silt fencing will be placed along the down-gradient sides of the property to prevent silt from escaping the construction area. A temporary construction entrance will be placed at the site entry/exit point to reduce tracking onto adjoining streets. A construction staging area will be used onsite to perform all vehicle maintenance and for equipment and material storage. A concrete truck washout pit will be placed on site to provide containment and easier cleanup of waste from concrete operations. The location of all structural temporary BMPs are shown within the Site Plans.

Description of Temporary BMPs

Silt Fence:

The purpose of a silt fence is to intercept and detain water-borne sediment from unprotected areas of a limited extent. Silt fence is used during the period of construction near the perimeter of a disturbed area to intercept sediment while allowing water to percolate through. This fence should remain in place until the disturbed area is permanently stabilized. Silt fence should not be used where there is a concentration of water in a channel or drainage way. If concentrated flow occurs after installation, corrective action must be taken such as placing a rock berm in the areas of concentrated flow.

Silt fencing within the site may be temporarily moved during the day to allow construction activity provided it is replaced and properly anchored to the ground at the end of the day. Silt fences on the perimeter of the site or around drainage ways should not be moved at any time.

Triangular Sediment Filter Dikes

Triangular sediment filter dikes (18"x18"x18" filter material with 6" square folded wire mesh frame) will be installed downgradient of the AST construction area with filter cloth placed over any existing stormwater collection drains. The dike and filter cloth will be held in place with cloth sandbags. The facility existing topography will not change as the AST will be placed on existing crushed rock.

Concrete Washout Area

The purpose of concrete washout areas is to prevent or reduce the discharge of pollutants to stormwater from concrete waste by conducting washout offsite, performing onsite washout in a designated area, and training employees and subcontractors.

The following steps will help reduce stormwater pollution from concrete wastes:



***BELL BOULEVARD C-STORE
WATER POLLUTION ABATEMENT PLAN***

- Incorporate requirements for concrete waste management into material supplier and subcontractor agreements.
- Avoid mixing excess amounts of fresh concrete.
- Perform washout of concrete trucks in designated areas only.
- Do not wash out concrete trucks into storm drains, open ditches, streets, or streams.
- Do not allow excess concrete to be dumped onsite, except in designated areas.
- For onsite washout:
 - Locate washout area at least 50 feet from sensitive features, storm drains, open ditches, or water bodies. Do not allow runoff from this area by constructing a temporary pit or bermed area large enough for liquid and solid waste.
 - Wash out wastes into the temporary pit where the concrete can set, be broken up, and then disposed properly.



**Temporary Stormwater Section
(TCEQ-0602)**

**Attachment G:
Drainage Area Map**

No upstream drainage currently exists that flows on-site.



**Temporary Stormwater Section
(TCEQ-0602)**

**Attachment H:
Temporary Sediment Pond(s) Plans and Calculations
(NOT APPLICABLE)**



Temporary Stormwater Section (TCEQ-0602)

Attachment I: Inspection and Maintenance for BMPs

Inspection and Maintenance Guidelines for Construction BMPs

Silt Fence – Section 1.4.3

- (1) Inspect all fencing weekly, and after any rainfall.
- (2) Remove sediment when buildup reaches 6 inches.
- (3) Replace any torn fabric or install a second line of fencing parallel to the torn section.
- (4) Replace or repair any sections crushed or collapsed in the course of construction activity. If a section of fence is obstructing vehicular access, consider relocating it to a spot where it will provide equal protection, but will not obstruct vehicles. A triangular filter dike may be preferable to a silt fence at common vehicle access points.
- (5) When construction is complete, the sediment should be disposed of in a manner that will not cause additional siltation and the prior location of the silt fence should be revegetated. The fence itself should be disposed of in an approved landfill.

Inlets – Section 1.4.11

- (1) Inspection should be made weekly and after each rainfall. Repair or replacement should be made promptly as needed by the contractor.
- (2) Remove sediment when buildup reaches a depth of 3 inches. Removed sediment should be deposited in a suitable area and in such a manner that it will not erode.
- (3) Check placement of device to prevent gaps between device and curb.
- (4) Inspect filter fabric and patch or replace if torn or missing.
- (5) Structures should be removed and the area stabilized only after the remaining drainage area has been properly stabilized.

Personnel Responsible for Inspections

The agent that performs the inspections should be knowledgeable of this general permit, familiar with the construction site, and knowledgeable of the SWPPP for the site. Documentation of the inspector's qualifications is to be included in the attached Inspector Qualifications Log.

Inspection Schedule

The primary operator is required to choose one of the two inspections listed below.

- Option 1:** Once every seven calendar days. If this alternative schedule is developed, then the inspection must occur regardless of whether or not there has been a rainfall event since the previous inspection.



Option 2: Once every 14 calendar days and within 24 hours of the end of a storm event of two inches or greater.

The inspections may occur on either schedule provided that documentation reflects the current schedule and that any changes to the schedule are conducted in accordance with the following provisions: the schedule may be changed a maximum of one time each month, the schedule change must be implemented at the beginning of a calendar month, and the reason for the schedule change must be documented (e.g., end of “dry” season and beginning of “wet” season).

If option 2 is the chosen frequency of inspections a rain gauge must be properly maintained on site or the storm event information from a weather station that is representative of the site location. For any day of rainfall during normal business hours that measures 0.25 inches or greater, proper documentation of the total rainfall measured for that day must be recorded.

Personnel provided by the permittee must inspect:

- disturbed areas of the construction site that have not been finally stabilized,
- areas used for storage of materials that are exposed to precipitation,
- structural controls (for evidence of, or the potential for, pollutants entering the drainage system),
- sediment and erosion control measures identified in the SWP3 (to ensure they are operating correctly), and
- locations where vehicles enter or exit the site (for evidence of off-site sediment tracking).

Reductions in Inspection Frequency

Where sites have been finally or temporarily stabilized or where runoff is unlikely due to winter conditions (e.g., site is covered with snow, ice, or frozen ground exists), inspections must be conducted at least once every month. In arid, semi-arid, or drought-stricken areas, inspections must be conducted at least once every month and within 24 hours after the end of a storm event of 0.5 inches or greater. A record of the total rainfall measured, as well as the approximate beginning and ending dates of winter or drought conditions resulting in monthly frequency of inspections in the attached Rain Gauge Log.

In the event of flooding or other uncontrollable situations which prohibit access to the inspection sites, inspections must be conducted as soon as access is practicable.

Inspection Report Forms

Use the Inspection Report Forms given as a checklist to ensure that all required areas of the construction site are addressed. There is space to document the inspector’s name as well as when the inspections regularly take place. The tables will document that the required area was inspected. (If there were any areas of concern, briefly describe them in this space with a more detailed description in the narrative section. Use the last table to document any discharges found during the inspections).

Describe how effective the installed BMPs are performing. Describe any BMP failures that were noted during the investigation and describe any maintenance required due to the failure. If new BMPs are needed



**BELL BOULEVARD C-STORE
WATER POLLUTION ABATEMENT PLAN**

as the construction site changes, the inspector can use the space at the bottom of the section to list BMPs to be implemented before the next inspection.

Describe the inspector's qualifications, how the inspection was conducted, and describe any areas of non-compliance in detail. If an inspection report does not identify any incidents of non-compliance, then it must contain a certifying signature stating that the facility or site is in compliance. The report must be signed by a person and in a manner required by 30 TAC 305.128. There is space at the end of the form to allow for this certifying signature.

Whenever an inspection shows that BMP modifications are needed to better control pollutants in runoff, the changes must be completed within seven calendar days following the inspection. If existing BMPs are modified or if additional BMPs are needed, you must describe your implementation schedule, and wherever possible, make the required BMP changes before the next storm event.

The Inspection Report Form functions as the required report and must be signed in accordance with TCEQ rules at 30 TAC 305.128.

Corrective Action

Personnel Responsible for Corrective Actions

Both Primary and Secondary Operators are responsible for maintaining all necessary Corrective Actions. If an individual is specifically identified as the responsible party for modifying the contact information for that individual should be documented in the attached Inspector Qualifications Log.

Corrective Action Forms

The Temporary BMPs must be modified based on the results of inspections, as necessary, to better control pollutants in runoff. Revisions must be completed within seven (7) calendar days following the inspection. If existing BMPs are modified or if additional BMPs are necessary, an implementation schedule must be described in the attached forms and wherever possible those changes implemented before the next storm event. If implementation before the next anticipated storm event is impracticable, these changes must be implemented as soon as practicable. Actions taken as a result of inspections must be properly documented by completing the corrective action forms given.



Inspector Qualifications Log*

Inspector Name: _____

Qualifications (Check as appropriate and provide description):

Training Course _____

Supervised Experience _____

Other _____

Inspector Name: _____

Qualifications (Check as appropriate and provide description):

Training Course _____

Supervised Experience _____

Other _____

Inspector Name: _____

Qualifications (Check as appropriate and provide description):

Training Course _____

Supervised Experience _____

Other _____

Inspector Name: _____

Qualifications (Check as appropriate and provide description):

Training Course _____

Supervised Experience _____

Other _____

Inspector Name: _____

Qualifications (Check as appropriate and provide description):

Training Course _____

Supervised Experience _____

Other _____

Inspector Name: _____

Qualifications (Check as appropriate and provide description):

Training Course _____

Supervised Experience _____

Other _____

*The agent that performs the inspections should be knowledgeable of this general permit, familiar with the construction site, and knowledgeable of the SWPPP for the site. The contractor is to provide an inspector with a CPESC, CESSWI, or CISEC certification.

Construction Activity Sequence Log*

Name of Operator	Projected Dates Month/Year	Activity Disturbing Soil clearing, excavation, etc.	Location on-site where activity will be conducted	Acreage being disturbed

*Construction activity sequences for linear projects may be conducted on a rolling basis. As a result, construction activities may be at different stages at different locations in the project area. The Contractor is required to complete and update the schedule and adjust as necessary.

Stabilization Activities Log*

Date Activity Initiated	Description of Activity	Description of Stabilization Measure and Location	Date Activity Ceased (Indicate Temporary or Permanent)	Date When Stabilization Measures Initiated

*Stabilization and erosion control practices may include, but are not limited to, establishing temporary or permanent vegetation, mulching, geotextiles, sod stabilization, vegetative buffer strips, and protecting existing trees and vegetation. List practices used where they are located, when they will be implemented, and whether they are temporary (interim) or permanent.



Rain Gauge Log

Date	Location of Rain Gauge	Gauge Reading

General Information			
Name of Project		Tracking Number	Inspection Date
Inspector Name, Title & Contact Information			
Present Phase of Construction			
Inspection Location (if multiple inspections are required, specify location where this inspection is being conducted)			
<p>Inspection Frequency</p> <p>Standard Frequency: <input type="checkbox"/> Weekly <input type="checkbox"/> Every 14 days and within 24 hours of a 0.25" rain</p> <p>Increased Frequency: <input type="checkbox"/> Every 7 days and within 24 hours of a 0.25" rain</p> <p>Reduced Frequency:</p> <p><input type="checkbox"/> Once per month (for stabilized areas)</p> <p><input type="checkbox"/> Once per month and within 24 hours of a 0.25" rain (for arid, semi-arid, or drought-stricken areas during seasonally dry periods or during drought)</p> <p><input type="checkbox"/> Once per month (for frozen conditions where earth-disturbing activities are being conducted)</p>			
<p>Was this inspection triggered by a 0.25" storm event? <input type="checkbox"/> Yes <input type="checkbox"/> No</p> <p>If yes, how did you determine whether a 0.25" storm event has occurred?</p> <p><input type="checkbox"/> Rain gauge on site <input type="checkbox"/> Weather station representative of site. Specify weather station source.</p> <p>Total rainfall amount that triggered the inspection (in inches):</p>			
<p>Unsafe Conditions for Inspection</p> <p>Did you determine that any portion of your site was unsafe for inspection? <input type="checkbox"/> Yes <input type="checkbox"/> No</p> <p>If "yes," complete the following:</p> <p>○ Describe the conditions that prevented you from conducting the inspection in this location:</p> <p>○ Location(s) where conditions were found:</p>			



Condition and Effectiveness of Erosion and Sediment (E&S) Controls				
Type / Location of E&S Control	Repairs or Other Maintenance Needed?	Corrective Action Required?	Date on Which Maintenance of Corrective Action First Identified?	Notes
1.	<input type="checkbox"/> Yes <input type="checkbox"/> No	<input type="checkbox"/> Yes <input type="checkbox"/> No		
2.	<input type="checkbox"/> Yes <input type="checkbox"/> No	<input type="checkbox"/> Yes <input type="checkbox"/> No		
3.	<input type="checkbox"/> Yes <input type="checkbox"/> No	<input type="checkbox"/> Yes <input type="checkbox"/> No		
4.	<input type="checkbox"/> Yes <input type="checkbox"/> No	<input type="checkbox"/> Yes <input type="checkbox"/> No		
5.	<input type="checkbox"/> Yes <input type="checkbox"/> No	<input type="checkbox"/> Yes <input type="checkbox"/> No		
6.	<input type="checkbox"/> Yes <input type="checkbox"/> No	<input type="checkbox"/> Yes <input type="checkbox"/> No		
7.	<input type="checkbox"/> Yes <input type="checkbox"/> No	<input type="checkbox"/> Yes <input type="checkbox"/> No		
8.	<input type="checkbox"/> Yes <input type="checkbox"/> No	<input type="checkbox"/> Yes <input type="checkbox"/> No		
9.	<input type="checkbox"/> Yes <input type="checkbox"/> No	<input type="checkbox"/> Yes <input type="checkbox"/> No		



Condition and Effectiveness of Pollution Prevention (P ₂) Practices				
Type / Location of P ₂ Practices	Repairs or Other Maintenance Needed?	Corrective Action Required?	Identification Date	Notes
1.	<input type="checkbox"/> Yes <input type="checkbox"/> No	<input type="checkbox"/> Yes <input type="checkbox"/> No		
2.	<input type="checkbox"/> Yes <input type="checkbox"/> No	<input type="checkbox"/> Yes <input type="checkbox"/> No		
3.	<input type="checkbox"/> Yes <input type="checkbox"/> No	<input type="checkbox"/> Yes <input type="checkbox"/> No		
4.	<input type="checkbox"/> Yes <input type="checkbox"/> No	<input type="checkbox"/> Yes <input type="checkbox"/> No		
5.	<input type="checkbox"/> Yes <input type="checkbox"/> No	<input type="checkbox"/> Yes <input type="checkbox"/> No		
6.	<input type="checkbox"/> Yes <input type="checkbox"/> No	<input type="checkbox"/> Yes <input type="checkbox"/> No		
7.	<input type="checkbox"/> Yes <input type="checkbox"/> No	<input type="checkbox"/> Yes <input type="checkbox"/> No		
8.	<input type="checkbox"/> Yes <input type="checkbox"/> No	<input type="checkbox"/> Yes <input type="checkbox"/> No		
9.	<input type="checkbox"/> Yes <input type="checkbox"/> No	<input type="checkbox"/> Yes <input type="checkbox"/> No		



Stabilization of Exposed Soil			
Stabilization Area	Stabilization Method	Have you Initiated Stabilization?	Notes
1.		<input type="checkbox"/> YES <input type="checkbox"/> NO If yes, provide date:	
2.		<input type="checkbox"/> YES <input type="checkbox"/> NO If yes, provide date:	
3.		<input type="checkbox"/> YES <input type="checkbox"/> NO If yes, provide date:	
4.		<input type="checkbox"/> YES <input type="checkbox"/> NO If yes, provide date:	
Description of Discharges			
Was a stormwater discharge or other discharge occurring from any part of your site at the time of the inspection? <input type="checkbox"/> YES <input type="checkbox"/> NO			
If "YES," provide the following information for each point of discharge:			
Discharge Locations	Observations		
1.	Describe the discharge: At points of discharge and the channels and banks of surface waters in the immediate vicinity, are there any visible signs of erosion and / or sediment accumulation that can be attributed to your discharge? <input type="checkbox"/> YES. <input type="checkbox"/> NO If yes, describe what you see, specify the location(s) where these conditions were found, and indicate whether modification, maintenance, or corrective action is needed to resolve the issue:		
2.	Describe the discharge: At points of discharge and the channels and banks of surface waters in the immediate vicinity, are there any visible signs of erosion and / or sediment accumulation that can be attributed to your discharge? <input type="checkbox"/> YES. <input type="checkbox"/> NO If yes, describe what you see, specify the location(s) where these conditions were found, and indicate whether modification, maintenance, or corrective action is needed to resolve the issue:		
3.	Describe the discharge: At points of discharge and the channels and banks of surface waters in the immediate vicinity, are there any visible signs of erosion and / or sediment accumulation that can be attributed to your discharge? <input type="checkbox"/> YES. <input type="checkbox"/> NO If yes, describe what you see, specify the location(s) where these conditions were found, and indicate whether modification, maintenance, or corrective action is needed to resolve the issue:		



Contractor or Subcontractor Certification and Signature

“I certify under penalty of law that this document and all attachments were prepared under my direction or supervision in accordance with a system designed to assure that qualified personnel properly gathered and evaluated the information, submitted. Based on my inquiry of the person or persons who manage the system, or those persons directly responsible for gathering the information, the information submitted is, to the best of my knowledge and belief, true, accurate, and complete. I am, aware that there are significant penalties for submitting false information, including the possibility of fine and imprisonment for knowing violations.”

Signature of Contractor or Subcontractor: _____ **Date:** _____

Printed Name and Affiliation:

Certification and Signature by Permittee

“I certify under penalty of law that this document and all attachments were prepared under my direction or supervision in accordance with a system designed to assure that qualified personnel properly gathered and evaluated the information, submitted. Based on my inquiry of the person or persons who manage the system, or those persons directly responsible for gathering the information, the information submitted is, to the best of my knowledge and belief, true, accurate, and complete. I am, aware that there are significant penalties for submitting false information, including the possibility of fine and imprisonment for knowing violations.”

**Signature of Permittee or
“Duly Authorized Representative”:** _____ **Date:** _____

Printed Name and Affiliation:



Section A – Initial Report (Complete this section within 24 hours of discovering the condition that triggered corrective action.)			
Name of Project:		Tracking Number:	Today's Date
Date Problem First Discovered:		Time Problem First Discovered:	
Name of Individual Completing this Form:		Contact Information:	
<p>What site conditions triggered the requirement to conduct corrective action:</p> <p><input type="checkbox"/> A required stormwater control was never installed, was installed incorrectly, or not in accordance with the requirements in Part 2 and/or Part 3</p> <p><input type="checkbox"/> The stormwater controls that have been installed and maintained are not effective enough for the discharge to meet applicable water quality standards</p> <p><input type="checkbox"/> A prohibited discharge has occurred or is occurring</p> <p>Provide a description of the problem:</p> <p>Deadline for completing corrective action (Enter date that is either: (1) no more than 7 calendar days after the date you discovered the problem, or (2) if it is infeasible to complete work within the first 7 days, enter the date that is as soon as practicable following the 7th day):</p> <p>If your estimated date of completion falls after the 7-day deadline, explain (1) why you believe it is infeasible to complete work within 7 days, and (2) why the date you have established for making the new or modified stormwater control operational is the soonest practicable timeframe:</p>			
Section B – Corrective Action Progress (Complete this section no later than 7 calendar days after discovering the condition that triggered corrective action.)			
Section B.1 – Why the Problem Occurred			
Cause(s) of Problem (Add an additional sheet if necessary)		How This Was Determined and the Date You Determined the Cause	
1.		1.	
2.		2.	
Section B.2 – Stormwater Control Modifications to be Implemented to Correct the Problem			
List of Stormwater control Modification(s) Needed to Correct Problem (Add an additional sheet if necessary)	Completion Date	SWPPP Update Necessary?	Notes
1.		<input type="checkbox"/> Yes <input type="checkbox"/> No Date:	
2.		<input type="checkbox"/> Yes <input type="checkbox"/> No Date:	



Section A – Initial Report (Complete this section within 24 hours of discovering the condition that triggered corrective action.)			
Name of Project:	Tracking Number:	Today's Date	
Date Problem First Discovered:	Time Problem First Discovered:		
Name of Individual Completing this Form:	Contact Information:		
What site conditions triggered the requirement to conduct corrective action: <input type="checkbox"/> A required stormwater control was never installed, was installed incorrectly, or not in accordance with the requirements in Part 2 and/or Part 3 <input type="checkbox"/> The stormwater controls that have been installed and maintained are not effective enough for the discharge to meet applicable water quality standards <input type="checkbox"/> A prohibited discharge has occurred or is occurring Provide a description of the problem: Deadline for completing corrective action (Enter date that is either: (1) no more than 7 calendar days after the date you discovered the problem, or (2) if it is infeasible to complete work within the first 7 days, enter the date that is as soon as practicable following the 7 th day): If your estimated date of completion falls after the 7-day deadline, explain (1) why you believe it is infeasible to complete work within 7 days, and (2) why the date you have established for making the new or modified stormwater control operational is the soonest practicable timeframe:			
Section B – Corrective Action Progress (Complete this section no later than 7 calendar days after discovering the condition that triggered corrective action.)			
Section B.1 – Why the Problem Occurred			
Cause(s) of Problem (Add an additional sheet if necessary)	How This Was Determined and the Date You Determined the Cause		
1.	1.		
2.	2.		
Section B.2 – Stormwater Control Modifications to be Implemented to Correct the Problem			
List of Stormwater control Modification(s) Needed to Correct Problem (Add an additional sheet if necessary)	Completion Date	SWPPP Update Necessary?	Notes
1.		<input type="checkbox"/> Yes <input type="checkbox"/> No Date:	
2.		<input type="checkbox"/> Yes <input type="checkbox"/> No Date:	



Contractor or Subcontractor Certification and Signature

“I certify under penalty of law that this document and all attachments were prepared under my direction or supervision in accordance with a system designed to assure that qualified personnel properly gathered and evaluated the information, submitted. Based on my inquiry of the person or persons who manage the system, or those persons directly responsible for gathering the information, the information submitted is, to the best of my knowledge and belief, true, accurate, and complete. I am, aware that there are significant penalties for submitting false information, including the possibility of fine and imprisonment for knowing violations.”

Signature of Contractor or Subcontractor: _____ **Date:** _____

Printed Name and Affiliation:

Certification and Signature by Permittee

“I certify under penalty of law that this document and all attachments were prepared under my direction or supervision in accordance with a system designed to assure that qualified personnel properly gathered and evaluated the information, submitted. Based on my inquiry of the person or persons who manage the system, or those persons directly responsible for gathering the information, the information submitted is, to the best of my knowledge and belief, true, accurate, and complete. I am, aware that there are significant penalties for submitting false information, including the possibility of fine and imprisonment for knowing violations.”

**Signature of Permittee or
“Duly Authorized Representative”:** _____ **Date:** _____

Printed Name and Affiliation:



Temporary Stormwater Section (TCEQ-0602)

Attachment J: Schedule of Interim and Permanent Soil Stabilization Practices

Interim Vegetative Stabilization

Interim soil stabilization will not be required.

Permanent Vegetative Stabilization

Construction practices shall disturb the minimal amount of existing ground cover as required for land clearing, grading, and construction activity for the shortest amount of time possible to minimize the potential of erosion and sedimentation from the site. Existing vegetation shall be maintained and left in place until it is necessary to disturb construction activity. For this project, the following stabilization practices will be implemented:

1. Hydraulic Mulch and Seeding: Disturbed areas subject to erosion shall be stabilized with hydraulic mulch and/or seeded and watered to provide interim stabilization.
2. Sodding and Wood Mulch: As per the project landscaping plan, sodding and wood mulch will be applied to landscaped areas to provide permanent stabilization prior to project completion.

Records of the following shall be maintained:

1. The dates when major grading activities occur,
2. The dates when construction activities temporarily or permanently cease on a portion of the site, and
3. The dates when stabilization measures are initiated.

Stabilization measures must be initiated as soon as practical in portions of the site where construction activities have temporarily or permanently ceased, and except as provided in the following, must be initiated no more than fourteen (14) days after the construction activity in that portion of the site has temporarily or permanently ceased:



***BELL BOULEVARD C-STORE
WATER POLLUTION ABATEMENT PLAN***

Where the initiation of stabilization measures by the 14th day after construction activity temporarily or permanently ceased is precluded by snow cover or frozen ground conditions, stabilization measures must be initiated as soon as practical.

Where construction activity on a portion of the site is temporarily ceased and earth disturbing activities will be resumed within twenty-one (21) days, temporary stabilization measures do not have to be initiated on that portion of the site.

In arid areas (areas with an average rainfall of 0-10 inches), semiarid areas (areas with an average annual rainfall of 10 to 20 inches), and areas experiencing droughts where the initiation of stabilization measures by the 14th day after construction activity has temporarily or permanently ceased is precluded by seasonably arid conditions, stabilization measures must be initiated as soon as practical.

EXISTING IMPERVIOUS COVER = 10,460 SF
REMAINS UNCHANGED BY THIS PLAN

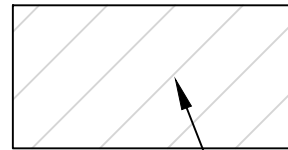

EXISTING IMPERVIOUS COVER
CALCULATION

PIPE CHASE LOCATIONS

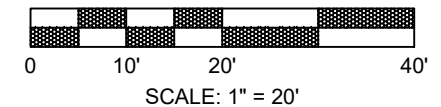
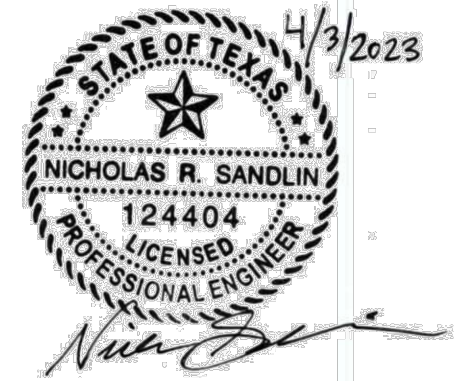

IF DRAWING BAR DOES NOT MEASURE 2"
THIS PRINT IS NOT TO SCALE



WARNING !!!! CONTRACTOR TO FIELD VERIFY
ALL EXIST. UTILITIES VERTICALLY AND
HORIZONTALLY PRIOR TO CONSTRUCTION.
THE CONTRACTOR IS TO CONTACT ENGINEER
IF ANY EXISTING UTILITY INFORMATION
DIFFERS FROM DATA SHOWN IN THE PLANS.
CALL 811 BEFORE YOU DIG.



TBPELS FIRM #21356
4501 WHISPERING VALLEY DRIVE UNIT 27 AUSTIN, TX 78727

SITE LAYOUT PLAN

BELL BLVD C-STORE TCEQ WPAP

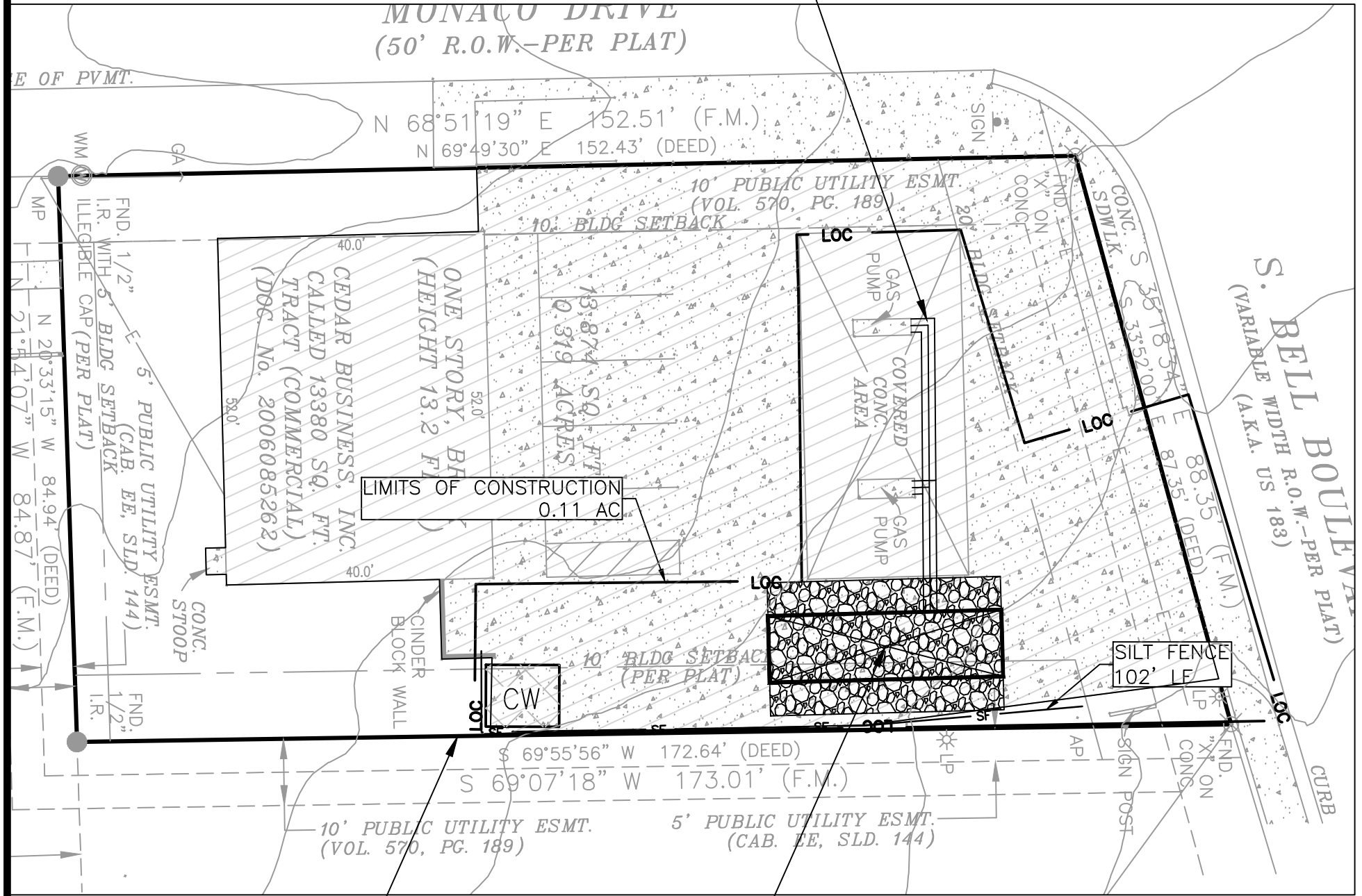

UNDERGROUND STORAGE TANK
REFER TO TANK SPECIFICATION

PROPERTY BOUNDARY

REV. NO.	BY	DATE	REVISION DESCRIPTION

SHEET
1
OF 1

Permanent Stormwater Section
TCEQ-0600



Sandlin Services, LLC
P: (806)679-7303
TBPELS Firm # 21356

April 20, 2023

Edwards Aquifer Protection Program
TCEQ Region 13 and Region 11
14250 Judson Road
San Antonio, Texas 78233

Bell Blvd. C-Store WPAP Permanent Storm Exception Request

Review Team,

Based on the information provided within this letter packet, we respectfully have provided verification that WPAP Permanent stormwater shall not be required considering the I.C. pre-dates the EAPP Rules for Williamson County. Should you have any questions or need anything further at this time, please contact me at (806) 679-7303.

Sincerely,

Nick Sandlin, P.E.
President & Principal
TBPELS Firm# 21356

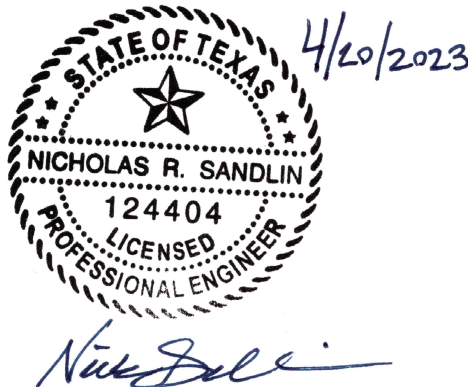

1995 Aerial



Impervious Cover – 1971 Canopy Only - 1993

Property: R071136 Owner: MICRO 290 LLC Property Address: 2509 BELL BLVD, CEDAR PARK, TX 78613

[Details](#) [Map](#) [Market Analysis](#) [Market Data Map](#) [Notice of Appraised Value](#)

2023 GENERAL INFORMATION

Property Status: **Active**
 Property Type: **C3**
 Legal Description: **S4478 - Riviera Springs North Sec B, ACRES 0.319**
 Neighborhood: **R45MI - MINI-MART CONVENIENCE STORE IN RR - RESEARCH / 620**
 Account: **R-16-5100-0000-000CA**
 Map Number: **4-6618**

2023 OWNER INFORMATION

Owner Name: **MICRO 290 LLC**
 Owner ID:
 Exemptions:
 Percent Ownership: **100%**
 Mailing Address: **13917 CAROLINA LN AUSTIN, TX 78717**
 Agent: -

2023 IMPROVEMENTS

[Expand/Collapse All](#)

Improvement #1: - State Code: **F1 - Real, Commercial** Homesite: **No** Total Main Area (Exterior Measured): **2,080 Sq. Ft** Market Value: **\$643,511**

RECORD	TYPE	YEAR BUILT	SQ. FT	VALUE	ADD'L INFO
1	Main Area	1971	2,080	\$559,196	Details
2	Open Porch	-	240	\$16,131	Details
3	Canopy	1993	1,248	\$50,328	Details
4	Concrete	-	1,000	\$4,464	Details
5	Asphalt	-	6,000	\$13,392	Details

Agent Authorization
TCEQ-0599

Agent Authorization Form
For Required Signature
Edwards Aquifer Protection Program
Relating to 30 TAC Chapter 213
Effective June 1, 1999

I Mr. Rafiq Karediya
Print Name

Owner
Title - Owner/President/Other

of Micro 290, LLC
Corporation/Partnership/Entity Name

have authorized Mr. Chad M. Copeland, PG, PWS
Print Name of Agent/Engineer

of Ranger Environmental Services, LLC
Print Name of Firm

to represent and act on the behalf of the above named Corporation, Partnership, or Entity for the purpose of preparing and submitting this plan application to the Texas Commission on Environmental Quality (TCEQ) for the review and approval consideration of regulated activities.

I also understand that:

1. The applicant is responsible for compliance with 30 Texas Administrative Code Chapter 213 and any condition of the TCEQ's approval letter. The TCEQ is authorized to assess administrative penalties of up to \$10,000 per day per violation.
2. For those submitting an application who are not the property owner, but who have the right to control and possess the property, additional authorization is required from the owner.
3. Application fees are due and payable at the time the application is submitted. The application fee must be sent to the TCEQ cashier or to the appropriate regional office. The application will not be considered until the correct fee is received by the commission.
4. A notarized copy of the Agent Authorization Form must be provided for the person preparing the application, and this form must accompany the completed application.
5. No person shall commence any regulated activity on the Edwards Aquifer Recharge Zone, Contributing Zone or Transition Zone until the appropriate application for the activity has been filed with and approved by the Executive Director.

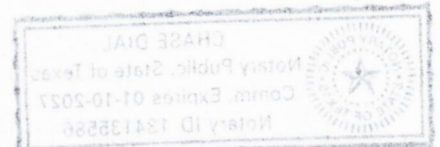

SIGNATURE PAGE:

[Signature]
Applicant's Signature

3/21/23
Date

THE STATE OF Texas §

County of Williamson §

BEFORE ME, the undersigned authority, on this day personally appeared Rat;g Kareeda known to me to be the person whose name is subscribed to the foregoing instrument, and acknowledged to me that (s)he executed same for the purpose and consideration therein expressed.

GIVEN under my hand and seal of office on this 21st day of March, 2023.

[Signature]
NOTARY PUBLIC

Chase Dial
Typed or Printed Name of Notary

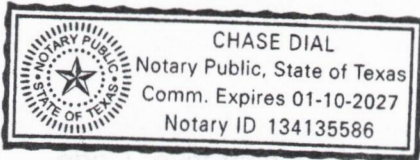

MY COMMISSION EXPIRES: 01-10-27

Agent Authorization Form
For Required Signature
Edwards Aquifer Protection Program
Relating to 30 TAC Chapter 213
Effective June 1, 1999

I Mr. Rafiq Karediya
Print Name

Owner
Title - Owner/President/Other

of Micro 290, LLC
Corporation/Partnership/Entity Name

have authorized Mr. Nick Sandlin, PE
Print Name of Agent/Engineer

of Sandlin Services, LLC
Print Name of Firm

to represent and act on the behalf of the above named Corporation, Partnership, or Entity for the purpose of preparing and submitting this plan application to the Texas Commission on Environmental Quality (TCEQ) for the review and approval consideration of regulated activities.

I also understand that:

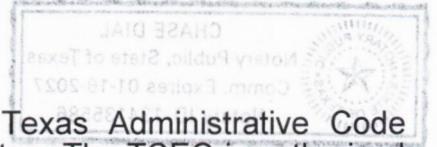

1. The applicant is responsible for compliance with 30 Texas Administrative Code Chapter 213 and any condition of the TCEQ's approval letter. The TCEQ is authorized to assess administrative penalties of up to \$10,000 per day per violation.
2. For those submitting an application who are not the property owner, but who have the right to control and possess the property, additional authorization is required from the owner.
3. Application fees are due and payable at the time the application is submitted. The application fee must be sent to the TCEQ cashier or to the appropriate regional office. The application will not be considered until the correct fee is received by the commission.
4. A notarized copy of the Agent Authorization Form must be provided for the person preparing the application, and this form must accompany the completed application.
5. No person shall commence any regulated activity on the Edwards Aquifer Recharge Zone, Contributing Zone or Transition Zone until the appropriate application for the activity has been filed with and approved by the Executive Director.

SIGNATURE PAGE:

Rath
Applicant's Signature

3/21/23
Date

THE STATE OF TEXAS §

County of Williamson §

BEFORE ME, the undersigned authority, on this day personally appeared Ruth Ware known to me to be the person whose name is subscribed to the foregoing instrument, and acknowledged to me that (s)he executed same for the purpose and consideration therein expressed.

GIVEN under my hand and seal of office on this 21st day of March, 2023.

Chase Dial
NOTARY PUBLIC

Chase Dial
Typed or Printed Name of Notary

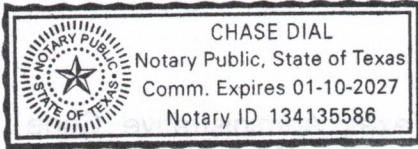

MY COMMISSION EXPIRES: 01-10-27

Application Fee Form
TCEQ-0574

Application Fee Form

Texas Commission on Environmental Quality

Name of Proposed Regulated Entity: Super 365

Regulated Entity Location: 2509 S. Bell Blvd., Cedar Park, Texas

Name of Customer: Micro 290, LLC

Contact Person: Rafiq Kareeya

Phone: (512) 850-3331

Customer Reference Number (if issued): CN _____

Regulated Entity Reference Number (if issued): RN 102269818

Austin Regional Office (3373)

Hays

Travis

Williamson

San Antonio Regional Office (3362)

Bexar

Medina

Uvalde

Comal

Kinney

Application fees must be paid by check, certified check, or money order, payable to the **Texas Commission on Environmental Quality**. Your canceled check will serve as your receipt. **This form must be submitted with your fee payment.** This payment is being submitted to:

Austin Regional Office

San Antonio Regional Office

Mailed to: TCEQ - Cashier

Overnight Delivery to: TCEQ - Cashier

Revenues Section

Mail Code 214

P.O. Box 13088

Austin, TX 78711-3088

12100 Park 35 Circle

Building A, 3rd Floor

Austin, TX 78753

(512)239-0357

Site Location (Check All That Apply):

Recharge Zone

Contributing Zone

Transition Zone

<i>Type of Plan</i>	<i>Size</i>	<i>Fee Due</i>
Water Pollution Abatement Plan, Contributing Zone Plan: One Single Family Residential Dwelling	Acres	\$
Water Pollution Abatement Plan, Contributing Zone Plan: Multiple Single Family Residential and Parks	Acres	\$
Water Pollution Abatement Plan, Contributing Zone Plan: Non-residential	Acres	\$
Sewage Collection System	L.F.	\$
Lift Stations without sewer lines	Acres	\$
Underground or Aboveground Storage Tank Facility	1 Tanks	\$ 650
Piping System(s)(only)	Each	\$
Exception	Each	\$
Extension of Time	Each	\$

Signature: _____



Date: 4/24/2024

Application Fee Schedule

Texas Commission on Environmental Quality

Edwards Aquifer Protection Program 30 TAC Chapter 213 (effective 05/01/2008)

Water Pollution Abatement Plans and Modifications

Contributing Zone Plans and Modifications

<i>Project</i>	<i>Project Area in Acres</i>	<i>Fee</i>
One Single Family Residential Dwelling	< 5	\$650
Multiple Single Family Residential and Parks	< 5	\$1,500
	5 < 10	\$3,000
	10 < 40	\$4,000
	40 < 100	\$6,500
	100 < 500	\$8,000
	≥ 500	\$10,000
Non-residential (Commercial, industrial, institutional, multi-family residential, schools, and other sites where regulated activities will occur)	< 1	\$3,000
	1 < 5	\$4,000
	5 < 10	\$5,000
	10 < 40	\$6,500
	40 < 100	\$8,000
	≥ 100	\$10,000

Organized Sewage Collection Systems and Modifications

<i>Project</i>	<i>Cost per Linear Foot</i>	<i>Minimum Fee- Maximum Fee</i>
Sewage Collection Systems	\$0.50	\$650 - \$6,500

Underground and Aboveground Storage Tank System Facility Plans and Modifications

<i>Project</i>	<i>Cost per Tank or Piping System</i>	<i>Minimum Fee- Maximum Fee</i>
Underground and Aboveground Storage Tank Facility	\$650	\$650 - \$6,500

Exception Requests

<i>Project</i>	<i>Fee</i>
Exception Request	\$500

Extension of Time Requests

<i>Project</i>	<i>Fee</i>
Extension of Time Request	\$150

Core Data Form
TCEQ-10400



TCEQ Core Data Form

For detailed instructions on completing this form, please read the Core Data Form Instructions or call 512-239-5175.

SECTION I: General Information

1. Reason for Submission (If other is checked please describe in space provided.)		
<input checked="" type="checkbox"/> New Permit, Registration or Authorization (Core Data Form should be submitted with the program application.)		
<input type="checkbox"/> Renewal (Core Data Form should be submitted with the renewal form)	<input checked="" type="checkbox"/> Other EAPP - UST Facility Plan	
2. Customer Reference Number (if issued)	Follow this link to search for CN or RN numbers in Central Registry**	3. Regulated Entity Reference Number (if issued)
CN		RN 102269818

SECTION II: Customer Information

4. General Customer Information		5. Effective Date for Customer Information Updates (mm/dd/yyyy)		03/20/2023	
<input checked="" type="checkbox"/> New Customer <input type="checkbox"/> Update to Customer Information <input type="checkbox"/> Change in Regulated Entity Ownership <input type="checkbox"/> Change in Legal Name (Verifiable with the Texas Secretary of State or Texas Comptroller of Public Accounts)					
The Customer Name submitted here may be updated automatically based on what is current and active with the Texas Secretary of State (SOS) or Texas Comptroller of Public Accounts (CPA).					
6. Customer Legal Name (If an individual, print last name first: eg: Doe, John)				If new Customer, enter previous Customer below:	
Micro 290, LLC					
7. TX SOS/CPA Filing Number		8. TX State Tax ID (11 digits)		9. Federal Tax ID (9 digits)	10. DUNS Number (if applicable)
804566215				88-2337637	
11. Type of Customer:		<input type="checkbox"/> Corporation		<input type="checkbox"/> Individual	
Government: <input type="checkbox"/> City <input type="checkbox"/> County <input type="checkbox"/> Federal <input type="checkbox"/> Local <input type="checkbox"/> State <input type="checkbox"/> Other		<input type="checkbox"/> Sole Proprietorship		Partnership: <input type="checkbox"/> General <input checked="" type="checkbox"/> Limited	
12. Number of Employees				13. Independently Owned and Operated?	
<input checked="" type="checkbox"/> 0-20 <input type="checkbox"/> 21-100 <input type="checkbox"/> 101-250 <input type="checkbox"/> 251-500 <input type="checkbox"/> 501 and higher				<input checked="" type="checkbox"/> Yes <input type="checkbox"/> No	
14. Customer Role (Proposed or Actual) – as it relates to the Regulated Entity listed on this form. Please check one of the following					
<input type="checkbox"/> Owner <input type="checkbox"/> Operator <input checked="" type="checkbox"/> Owner & Operator <input type="checkbox"/> Other: <input type="checkbox"/> Occupational Licensee <input type="checkbox"/> Responsible Party <input type="checkbox"/> VCP/BSA Applicant					
15. Mailing Address: 13917 CAROLINA LANE					
City		State		ZIP	
AUSTIN		TX		78717	
16. Country Mailing Information (if outside USA)			17. E-Mail Address (if applicable)		
18. Telephone Number		19. Extension or Code		20. Fax Number (if applicable)	

SECTION III: Regulated Entity Information**21. General Regulated Entity Information** (If 'New Regulated Entity' is selected, a new permit application is also required.)

New Regulated Entity Update to Regulated Entity Name Update to Regulated Entity Information

The Regulated Entity Name submitted may be updated, in order to meet TCEQ Core Data Standards (removal of organizational endings such as Inc, LP, or LLC).

22. Regulated Entity Name (Enter name of the site where the regulated action is taking place.)

Super 365

23. Street Address of the Regulated Entity:

2509 S. Bell

(No PO Boxes)

City	Cedar Park	State	TX	ZIP	78613	ZIP + 4	
-------------	------------	--------------	----	------------	-------	----------------	--

24. County

Williamson

If no Street Address is provided, fields 25-28 are required.

25. Description to Physical Location:

The subject site is located at the southwest corner of the intersection of S. Bell Blvd (US 183) and Monaco Drive.

26. Nearest City**State****Nearest ZIP Code**

Cedar Park

Tx

78613

Latitude/Longitude are required and may be added/updated to meet TCEQ Core Data Standards. (Geocoding of the Physical Address may be used to supply coordinates where none have been provided or to gain accuracy).

27. Latitude (N) In Decimal:

30.479841

28. Longitude (W) In Decimal:

-97.804064

Degrees

Minutes

Seconds

Degrees

Minutes

Seconds

30

28

47.43

-97

48

14.63

29. Primary SIC Code**30. Secondary SIC Code****31. Primary NAICS Code****32. Secondary NAICS Code**

(4 digits)

(4 digits)

(5 or 6 digits)

(5 or 6 digits)

5411

445120

33. What is the Primary Business of this entity? (Do not repeat the SIC or NAICS description.)

Retail Fueling and Convenience Store

34. Mailing Address:

13917 CAROLINA LANE

City

AUSTIN

State

TX

ZIP

78717

ZIP + 4**35. E-Mail Address:**

RAFIQA9@AOL.COM

36. Telephone Number**37. Extension or Code****38. Fax Number** (if applicable)

(512) 850-3331

() -

39. TCEQ Programs and ID Numbers Check all Programs and write in the permits/registration numbers that will be affected by the updates submitted on this form. See the Core Data Form instructions for additional guidance.

<input type="checkbox"/> Dam Safety	<input type="checkbox"/> Districts	<input checked="" type="checkbox"/> Edwards Aquifer	<input type="checkbox"/> Emissions Inventory Air	<input type="checkbox"/> Industrial Hazardous Waste
		TBD		
<input type="checkbox"/> Municipal Solid Waste	<input type="checkbox"/> New Source Review Air	<input type="checkbox"/> OSSF	<input checked="" type="checkbox"/> Petroleum Storage Tank	<input type="checkbox"/> PWS
			39567	
<input type="checkbox"/> Sludge	<input type="checkbox"/> Storm Water	<input type="checkbox"/> Title V Air	<input type="checkbox"/> Tires	<input type="checkbox"/> Used Oil
<input type="checkbox"/> Voluntary Cleanup	<input type="checkbox"/> Wastewater	<input type="checkbox"/> Wastewater Agriculture	<input type="checkbox"/> Water Rights	<input type="checkbox"/> Other:

SECTION IV: Preparer Information

40. Name:	Chad M. Copeland, PG, PWS		41. Title:	Senior Project Manager
42. Telephone Number	43. Ext./Code	44. Fax Number	45. E-Mail Address	
(512) 335-1785	124	(512) 335-0527	chad@rangerenv.com	

SECTION V: Authorized Signature

46. By my signature below, I certify, to the best of my knowledge, that the information provided in this form is true and complete, and that I have signature authority to submit this form on behalf of the entity specified in Section II, Field 6 and/or as required for the updates to the ID numbers identified in field 39.

Company:	MICRO 290.LLC	Job Title:	MANAGER	
Name (In Print):	RAFIQ KAREDIYA		Phone:	512-850-3331
Signature:			Date:	4/24/2024