



EVER ENGINEERING

Advanced Engineering Services

**Water Pollution Abatement Plan Modification
for
Savage Land Solutions, LLC.**

200 FM 32
San Marcos, Hays County, Texas 78666



December 2022

Project No, 22-0106

Ever Engineering, LLC.

3201 Cherry Ridge Drive, Suite A-106
San Antonio, Bexar County, Texas 78230
TBPE Firm Registration #19197

Table of Contents

Section 1: Edwards Aquifer Application Cover Page (TCEQ-20705)

Section 2: General Information Form (TCEQ-0587)

- Attachment A: Road Map
- Attachment B: USGS/Edwards Recharge Zone Map
- Attachment C: Project Description

Section 3: Geologic Assessment Form (TCEQ-0585)

- Attachment A: Geological Assessment

Section 4: Water Pollution Abatement Application Form (TCEQ-0590)

- Attachment A: Factors Affecting Water Quality
- Attachment B: Volume and Character of Stormwater
- Attachment C: Suitability Letter from Authorized Agent
(if OSSF is proposed)
- Attachment D: Exception to the Require Geologic Assessment
(if requesting an exception)
- Attachment E: Site Plan

Section 5: Temporary Storm Water Section (TCEQ-0602)

- Attachment A: Spill Response Actions
- Attachment B: Potential Sources of Contamination
- Attachment C: Sequence of Major Activities
- Attachment D: Temporary Best Management Practices and Measures
- Attachment E: Request to temporarily seal a Feature, if sealing a feature
- Attachment F: Structural Practices
- Attachment G: Proposed Drainage Area Plan
- Attachment H: Temporary Sediment Pond(s) Plans and Calculations
- Attachment I: Inspection and Maintenance for BMPs
- Attachment J: Schedule of Interim & Permanent Soil Stabilization Practices

Section 6: Permanent Storm Water Section (TCEQ-0600)

- Attachment A: A 20% or Less Impervious Cover Waiver, if project is multi-family residential, a school, or a small business and 20% or less impervious cover is proposed for the site
- Attachment B: BMPs for Upgradient Stormwater
- Attachment C: BMPs for on-site Stormwater
- Attachment D: BMPs for Surface Streams
- Attachment E: Request to Seal Features (if sealing a feature)
- Attachment F: Water Quality Treatment Calculations & Construction Plans
- Attachment G: Inspection, Maintenance, Repair and Retrofit Plan

Attachment H: Pilot-Scale Field Testing Plan, if BMPs not based on
Complying with Edwards Aquifer Rules: Technical
Guidance for BMPs
Attachment I: Measures for Minimizing Surface Stream Contamination

Section 7: Agent Authorization Form (TCEQ-0599)

Section 8: Application Fee Form (TCEQ-0574)

Section 9: Core Data Form (TCEQ-10400)



EVER ENGINEERING

Advanced Engineering Services

Section 1

Savage Land Solutions, LLC.

EDWARDS AQUIFER APPLICATION COVER PAGE (TCEQ-20705)

Texas Commission on Environmental Quality

Edwards Aquifer Application Cover Page

Our Review of Your Application

The Edwards Aquifer Program staff conducts an administrative and technical review of all applications. The turnaround time for administrative review can be up to 30 days as outlined in 30 TAC 213.4(e). Generally administrative completeness is determined during the intake meeting or within a few days of receipt. The turnaround time for technical review of an administratively complete Edwards Aquifer application is 90 days as outlined in 30 TAC 213.4(e). Please know that the review and approval time is directly impacted by the quality and completeness of the initial application that is received. In order to conduct a timely review, it is imperative that the information provided in an Edwards Aquifer application include final plans, be accurate, complete, and in compliance with [30 TAC 213](#).

Administrative Review

1. [Edwards Aquifer applications](#) must be deemed administratively complete before a technical review can begin. To be considered administratively complete, the application must contain completed forms and attachments, provide the requested information, and meet all the site plan requirements. The submitted application and plan sheets should be final plans. Please submit one full-size set of plan sheets with the original application, and half-size sets with the additional copies.

To ensure that all applicable documents are included in the application, the program has developed tools to guide you and web pages to provide all forms, checklists, and guidance. Please visit the below website for assistance: <http://www.tceq.texas.gov/field/eapp>.

2. This Edwards Aquifer Application Cover Page form (certified by the applicant or agent) must be included in the application and brought to the administrative review meeting.
3. Administrative reviews are scheduled with program staff who will conduct the review. Applicants or their authorized agent should call the appropriate regional office, according to the county in which the project is located, to schedule a review. The average meeting time is one hour.
4. In the meeting, the application is examined for administrative completeness. Deficiencies will be noted by staff and emailed or faxed to the applicant and authorized agent at the end of the meeting, or shortly after. Administrative deficiencies will cause the application to be deemed incomplete and returned.

An appointment should be made to resubmit the application. The application is re-examined to ensure all deficiencies are resolved. The application will only be deemed administratively complete when all administrative deficiencies are addressed.

5. If an application is received by mail, courier service, or otherwise submitted without a review meeting, the administrative review will be conducted within 30 days. The applicant and agent will be contacted with the results of the administrative review. If the application is found to be administratively incomplete, it can be retrieved from the regional office or returned by regular mail. If returned by mail, the regional office may require arrangements for return shipping.
6. If the geologic assessment was completed before October 1, 2004 and the site contains “possibly sensitive” features, the assessment must be updated in accordance with the *Instructions to Geologists* (TCEQ-0585 Instructions).

Technical Review

1. When an application is deemed administratively complete, the technical review period begins. The regional office will distribute copies of the application to the identified affected city, county, and groundwater conservation district whose jurisdiction includes the subject site. These entities and the public have 30 days to provide comments on the application to the regional office. All comments received are reviewed by TCEQ.
2. A site assessment is usually conducted as part of the technical review, to evaluate the geologic assessment and observe existing site conditions. The site must be accessible to our staff. The site boundaries should be

clearly marked, features identified in the geologic assessment should be flagged, roadways marked and the alignment of the Sewage Collection System and manholes should be staked at the time the application is submitted. If the site is not marked the application may be returned.

3. We evaluate the application for technical completeness and contact the applicant and agent via Notice of Deficiency (NOD) to request additional information and identify technical deficiencies. There are two deficiency response periods available to the applicant. There are 14 days to resolve deficiencies noted in the first NOD. If a second NOD is issued, there is an additional 14 days to resolve deficiencies. If the response to the second notice is not received, is incomplete or inadequate, or provides new information that is incomplete or inadequate, the application must be withdrawn or will be denied. Please note that because the technical review is underway, whether the application is withdrawn or denied **the application fee will be forfeited.**
4. The program has 90 calendar days to complete the technical review of the application. If the application is technically adequate, such that it complies with the Edwards Aquifer rules, and is protective of the Edwards Aquifer during and after construction, an approval letter will be issued. Construction or other regulated activity may not begin until an approval is issued.

Mid-Review Modifications

It is important to have final site plans prior to beginning the permitting process with TCEQ to avoid delays.

Occasionally, circumstances arise where you may have significant design and/or site plan changes after your Edwards Aquifer application has been deemed administratively complete by TCEQ. This is considered a “Mid-Review Modification”. Mid-Review Modifications may require redistribution of an application that includes the proposed modifications for public comment.

If you are proposing a Mid-Review Modification, two options are available:

- If the technical review has begun your application can be denied/withdrawn, your fees will be forfeited, and the plan will have to be resubmitted.
- TCEQ can continue the technical review of the application as it was submitted, and a modification application can be submitted at a later time.

If the application is denied/withdrawn, the resubmitted application will be subject to the administrative and technical review processes and will be treated as a new application. The application will be redistributed to the affected jurisdictions.

Please contact the regional office if you have questions. If your project is located in Williamson, Travis, or Hays County, contact TCEQ’s Austin Regional Office at 512-339-2929. If your project is in Comal, Bexar, Medina, Uvalde, or Kinney County, contact TCEQ’s San Antonio Regional Office at 210-490-3096

Please fill out all required fields below and submit with your application.

1. Regulated Entity Name: Savage Land Solutions				2. Regulated Entity No.: N/A, Has not been issued					
3. Customer Name: Dark Horse Syndicate, LLC				4. Customer No.: N/A, Has not been issued					
5. Project Type: (Please circle/check one)	<input checked="" type="radio"/> New	Modification		Extension	Exception				
6. Plan Type: (Please circle/check one)	<input checked="" type="radio"/> WPAP	<input type="radio"/> CZP	<input type="radio"/> SCS	<input type="radio"/> UST	<input type="radio"/> AST	<input type="radio"/> EXP	<input type="radio"/> EXT	Technical Clarification	Optional Enhanced Measures
7. Land Use: (Please circle/check one)	Residential		<input checked="" type="radio"/> Non-residential		8. Site (acres):		1.855		
9. Application Fee:	\$4,000		10. Permanent BMP(s):			Vegetative filter strips			
11. SCS (Linear Ft.):	N/A		12. AST/UST (No. Tanks):			1			
13. County:	HAYS		14. Watershed:			Upper San Marcos River			

Application Distribution

Instructions: Use the table below to determine the number of applications required. One original and one copy of the application, plus additional copies (as needed) for each affected incorporated city, county, and groundwater conservation district are required. Linear projects or large projects, which cross into multiple jurisdictions, can require additional copies. Refer to the “Texas Groundwater Conservation Districts within the EAPP Boundaries” map found at:

http://www.tceq.texas.gov/assets/public/compliance/field_ops/eapp/EAPP%20GWCD%20map.pdf

For more detailed boundaries, please contact the conservation district directly.

Austin Region			
County:	Hays	Travis	Williamson
Original (1 req.)	<u>1</u>	—	—
Region (1 req.)	<u>1</u>	—	—
County(ies)	<u>1</u>	—	—
Groundwater Conservation District(s)	<input type="checkbox"/> Edwards Aquifer Authority <input type="checkbox"/> Barton Springs/ Edwards Aquifer <input checked="" type="checkbox"/> Hays Trinity <input type="checkbox"/> Plum Creek	<input type="checkbox"/> Barton Springs/ Edwards Aquifer	NA
City(ies) Jurisdiction	<input type="checkbox"/> Austin <input type="checkbox"/> Buda <input type="checkbox"/> Dripping Springs <input type="checkbox"/> Kyle <input type="checkbox"/> Mountain City <input checked="" type="checkbox"/> San Marcos <input type="checkbox"/> Wimberley <input type="checkbox"/> Woodcreek	<input type="checkbox"/> Austin <input type="checkbox"/> Bee Cave <input type="checkbox"/> Pflugerville <input type="checkbox"/> Rollingwood <input type="checkbox"/> Round Rock <input type="checkbox"/> Sunset Valley <input type="checkbox"/> West Lake Hills	<input type="checkbox"/> Austin <input type="checkbox"/> Cedar Park <input type="checkbox"/> Florence <input type="checkbox"/> Georgetown <input type="checkbox"/> Jerrell <input type="checkbox"/> Leander <input type="checkbox"/> Liberty Hill <input type="checkbox"/> Pflugerville <input type="checkbox"/> Round Rock

San Antonio Region					
County:	Bexar	Comal	Kinney	Medina	Uvalde
Original (1 req.)	—	—	—	—	—
Region (1 req.)	—	—	—	—	—
County(ies)	—	—	—	—	—
Groundwater Conservation District(s)	<input type="checkbox"/> Edwards Aquifer Authority <input type="checkbox"/> Trinity-Glen Rose	<input type="checkbox"/> Edwards Aquifer Authority	<input type="checkbox"/> Kinney	<input type="checkbox"/> EAA <input type="checkbox"/> Medina	<input type="checkbox"/> EAA <input type="checkbox"/> Uvalde
City(ies) Jurisdiction	<input type="checkbox"/> Castle Hills <input type="checkbox"/> Fair Oaks Ranch <input type="checkbox"/> Helotes <input type="checkbox"/> Hill Country Village <input type="checkbox"/> Hollywood Park <input type="checkbox"/> San Antonio (SAWS) <input type="checkbox"/> Shavano Park	<input type="checkbox"/> Bulverde <input type="checkbox"/> Fair Oaks Ranch <input type="checkbox"/> Garden Ridge <input type="checkbox"/> New Braunfels <input type="checkbox"/> Schertz	NA	<input type="checkbox"/> San Antonio ETJ (SAWS)	NA

I certify that to the best of my knowledge, that the application is complete and accurate. This application is hereby submitted to TCEQ for administrative review and technical review.

Gerardo Villarreal

Print Name of Customer/Authorized Agent

Gerardo Villarreal

6/6/2023

Signature of Customer/Authorized Agent

Date

****FOR TCEQ INTERNAL USE ONLY****

Date(s) Reviewed:		Date Administratively Complete:	
Received From:		Correct Number of Copies:	
Received By:		Distribution Date:	
EAPP File Number:		Complex:	
Admin. Review(s) (No.):		No. AR Rounds:	
Delinquent Fees (Y/N):		Review Time Spent:	
Lat./Long. Verified:		SOS Customer Verification:	
Agent Authorization Complete/Notarized (Y/N):		Fee Check:	Payable to TCEQ (Y/N):
Core Data Form Complete (Y/N):			Signed (Y/N):
Core Data Form Incomplete Nos.:			Less than 90 days old (Y/N):



EVER ENGINEERING
Advanced Engineering Services

Section 2

Savage Land Solutions, LLC.
GENERAL INFORMATION FORM (TCEQ-0587)

General Information Form

Texas Commission on Environmental Quality

For Regulated Activities on the Edwards Aquifer Recharge and Transition Zones and Relating to 30 TAC §213.4(b) & §213.5(b)(2)(A), (B) Effective June 1, 1999

To ensure that the application is administratively complete, confirm that all fields in the form are complete, verify that all requested information is provided, consistently reference the same site and contact person in all forms in the application, and ensure forms are signed by the appropriate party.

Note: Including all the information requested in the form and attachments contributes to more streamlined technical reviews.

Signature

To the best of my knowledge, the responses to this form accurately reflect all information requested concerning the proposed regulated activities and methods to protect the Edwards Aquifer. This **General Information Form** is hereby submitted for TCEQ review. The application was prepared by:

Print Name of Customer/Agent: Ever Garza, P.E.

Date: 11/28/2022

Signature of Customer/Agent:



Project Information

1. Regulated Entity Name: Savage Land Solutions
2. County: Hays
3. Stream Basin: Upper San Marcos
4. Groundwater Conservation District (If applicable): Hays Trinity

5. Edwards Aquifer Zone:

- Recharge Zone
 Transition Zone

6. Plan Type:

- | | |
|--|--|
| <input checked="" type="checkbox"/> WPAP | <input type="checkbox"/> AST |
| <input type="checkbox"/> SCS | <input type="checkbox"/> UST |
| <input type="checkbox"/> Modification | <input type="checkbox"/> Exception Request |

7. Customer (Applicant):

Contact Person: Derrick Downing
Entity: Savage Land Solutions
Mailing Address: 200 FM 32
City, State: San Marcos, Texas Zip: 78666
Telephone: 512-648-9431 FAX: _____
Email Address: derrick@savagelandsolutions.com

8. Agent/Representative (If any):

Contact Person: Ever Garza, P.E.
Entity: Ever Engineering, LLC
Mailing Address: 3201 Cherry Ridge Dr. Ste A-106
City, State: San Antonio, TX Zip: 78230
Telephone: 210-572-9340 FAX: _____
Email Address: admin@everenc.com

9. Project Location:

- The project site is located inside the city limits of _____.
- The project site is located outside the city limits but inside the ETJ (extra-territorial jurisdiction) of San Marcos.
- The project site is not located within any city's limits or ETJ.

10. The location of the project site is described below. The description provides sufficient detail and clarity so that the TCEQ's Regional staff can easily locate the project and site boundaries for a field investigation.

200 FM 32 - Approximatley 350' west of the Hwy 12 and FM 32 intersection

11. **Attachment A – Road Map.** A road map showing directions to and the location of the project site is attached. The project location and site boundaries are clearly shown on the map.
12. **Attachment B - USGS / Edwards Recharge Zone Map.** A copy of the official 7 ½ minute USGS Quadrangle Map (Scale: 1" = 2000') of the Edwards Recharge Zone is attached. The map(s) clearly show:
- Project site boundaries.
 - USGS Quadrangle Name(s).
 - Boundaries of the Recharge Zone (and Transition Zone, if applicable).
 - Drainage path from the project site to the boundary of the Recharge Zone.
13. **The TCEQ must be able to inspect the project site or the application will be returned.** Sufficient survey staking is provided on the project to allow TCEQ regional staff to locate the boundaries and alignment of the regulated activities and the geologic or manmade features noted in the Geologic Assessment.
- Survey staking will be completed by this date: 1/31/2023

14. **Attachment C – Project Description.** Attached at the end of this form is a detailed narrative description of the proposed project. The project description is consistent throughout the application and contains, at a minimum, the following details:

- Area of the site
- Offsite areas
- Impervious cover
- Permanent BMP(s)
- Proposed site use
- Site history
- Previous development
- Area(s) to be demolished

15. Existing project site conditions are noted below:

- Existing commercial site
- Existing industrial site
- Existing residential site
- Existing paved and/or unpaved roads
- Undeveloped (Cleared)
- Undeveloped (Undisturbed/Uncleared)
- Other: _____

Prohibited Activities

16. I am aware that the following activities are prohibited on the Recharge Zone and are not proposed for this project:

- (1) Waste disposal wells regulated under 30 TAC Chapter 331 of this title (relating to Underground Injection Control);
- (2) New feedlot/concentrated animal feeding operations, as defined in 30 TAC §213.3;
- (3) Land disposal of Class I wastes, as defined in 30 TAC §335.1;
- (4) The use of sewage holding tanks as parts of organized collection systems; and
- (5) New municipal solid waste landfill facilities required to meet and comply with Type I standards which are defined in §330.41(b), (c), and (d) of this title (relating to Types of Municipal Solid Waste Facilities).
- (6) New municipal and industrial wastewater discharges into or adjacent to water in the state that would create additional pollutant loading.

17. I am aware that the following activities are prohibited on the Transition Zone and are not proposed for this project:

- (1) Waste disposal wells regulated under 30 TAC Chapter 331 (relating to Underground Injection Control);
- (2) Land disposal of Class I wastes, as defined in 30 TAC §335.1; and

- (3) New municipal solid waste landfill facilities required to meet and comply with Type I standards which are defined in §330.41 (b), (c), and (d) of this title.

Administrative Information

18. The fee for the plan(s) is based on:

- For a Water Pollution Abatement Plan or Modification, the total acreage of the site where regulated activities will occur.
 - For an Organized Sewage Collection System Plan or Modification, the total linear footage of all collection system lines.
 - For a UST Facility Plan or Modification or an AST Facility Plan or Modification, the total number of tanks or piping systems.
 - A request for an exception to any substantive portion of the regulations related to the protection of water quality.
 - A request for an extension to a previously approved plan.
19. Application fees are due and payable at the time the application is filed. If the correct fee is not submitted, the TCEQ is not required to consider the application until the correct fee is submitted. Both the fee and the Edwards Aquifer Fee Form have been sent to the Commission's:
- TCEQ cashier
 - Austin Regional Office (for projects in Hays, Travis, and Williamson Counties)
 - San Antonio Regional Office (for projects in Bexar, Comal, Kinney, Medina, and Uvalde Counties)
20. Submit one (1) original and one (1) copy of the application, plus additional copies as needed for each affected incorporated city, groundwater conservation district, and county in which the project will be located. The TCEQ will distribute the additional copies to these jurisdictions. The copies must be submitted to the appropriate regional office.
21. No person shall commence any regulated activity until the Edwards Aquifer Protection Plan(s) for the activity has been filed with and approved by the Executive Director.



EVER ENGINEERING

Advanced Engineering Services

**Section 2: GENERAL INFORMATION FORM (TCEQ-0587)
ATTACHMENT A**

**Savage Land Solutions, LLC.
ROAD MAP**

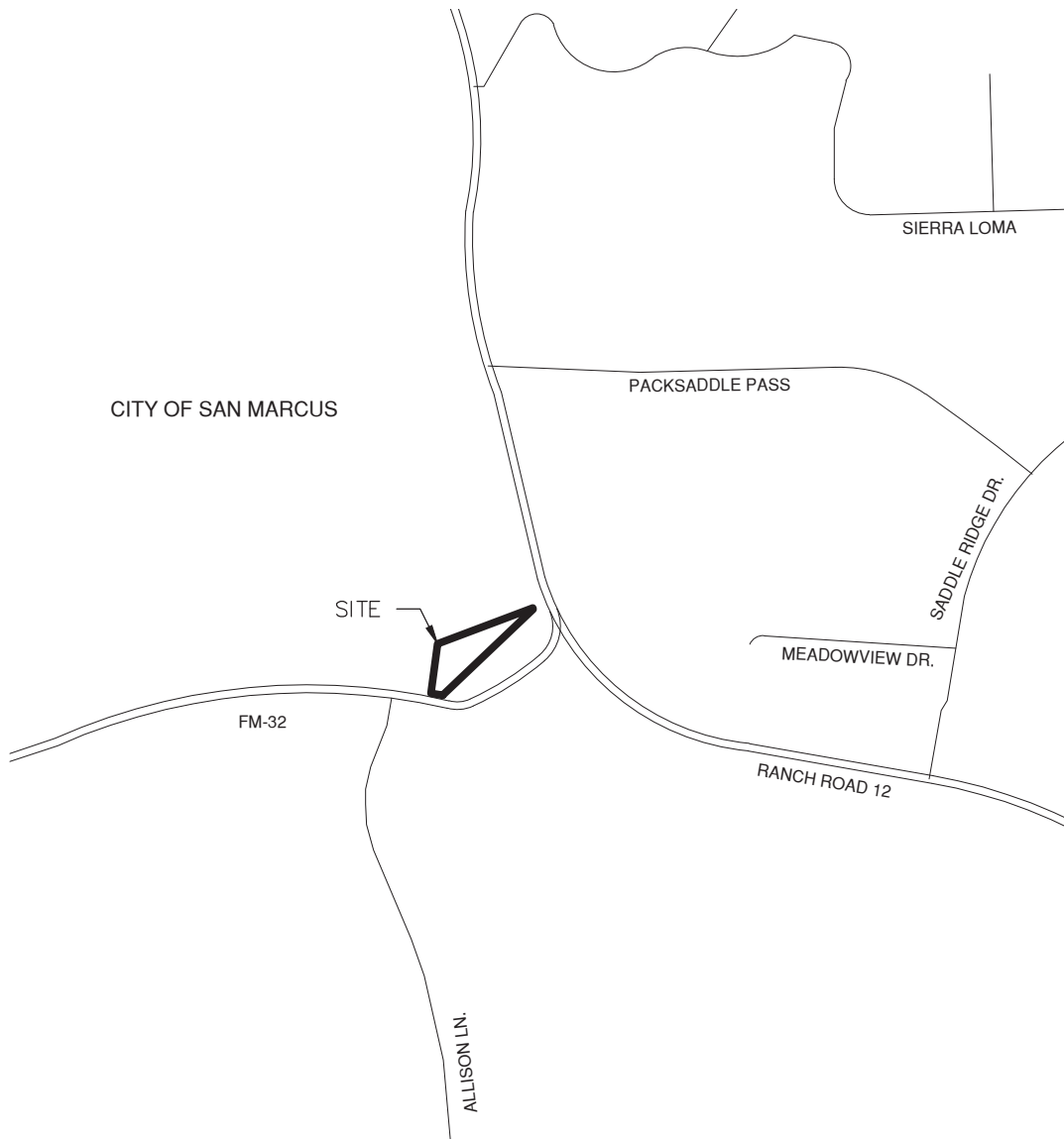

(NOT-TO-SCALE)

SHEET: EXH-1	<p><u>200 FM 32</u></p> <p>SAN MARCUS, TEXAS</p> <p>LOCATION MAP</p>	 <p>EVER ENGINEERING, LLC ADVANCED ENGINEERING & SURVEYING SERVICES</p> <p>3201 CHERRY RIDGE DR., STE. A-106 SAN ANTONIO, TX 78230 PHONE: 210.572.9340 FAX: 210.572.9344 TXBPE FIRM #19197 TBPLS FIRM #10174902 EVERENC.COM</p>
DRAWN: VB		
JOB NO.: 22-0106		
DATE: JULY 2022		



EVER ENGINEERING

Advanced Engineering Services

**Section 2: GENERAL INFORMATION FORM (TCEQ-0587)
ATTACHMENT B**

**Savage Land Solutions, LLC.
USGS/ EDWARDS RECHARGE ZONE MAP**

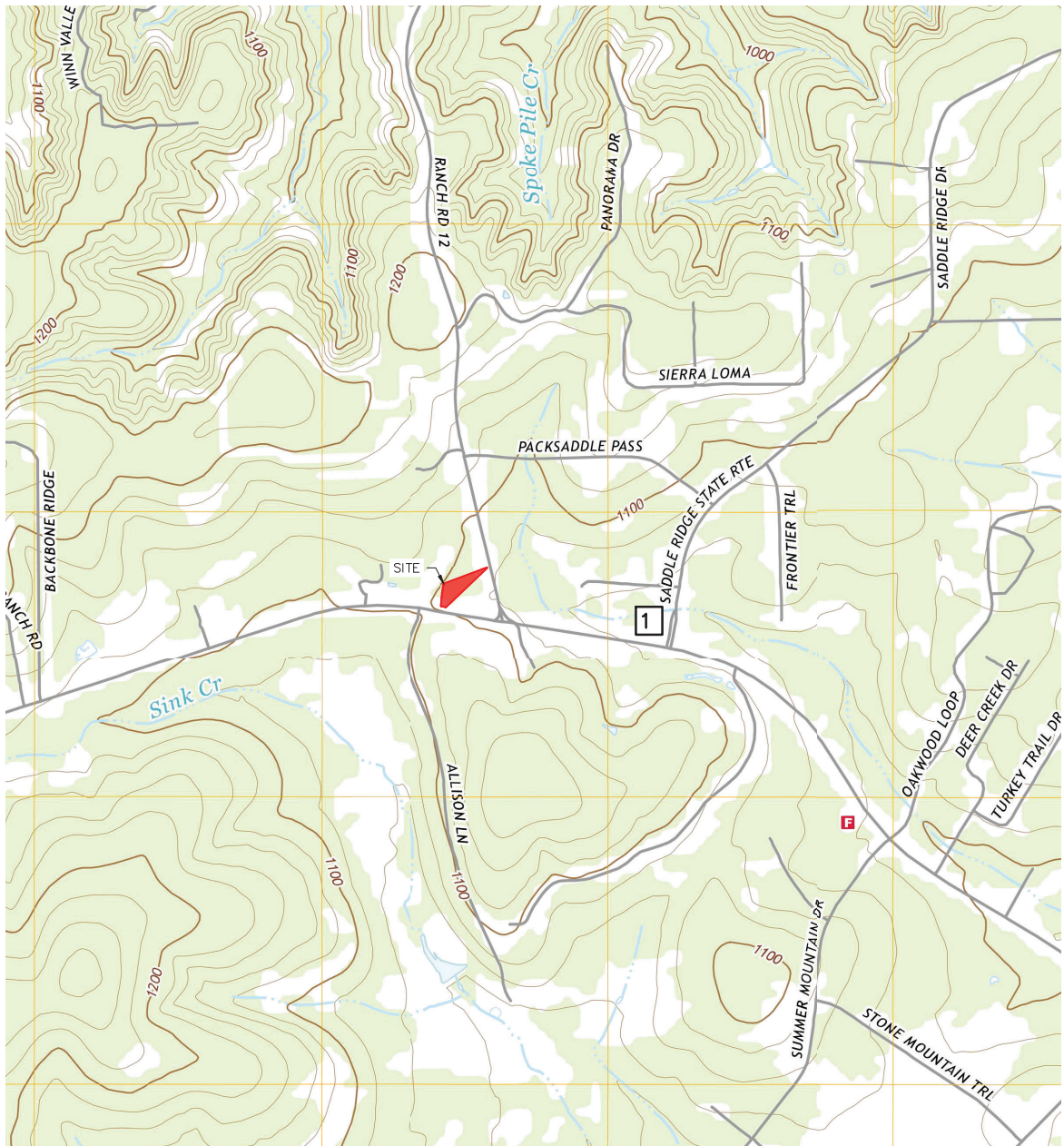

WIMBERLEY, TEXAS TNM GEOSPATIAL PDF

1 ~ 2,000 FT DOWNSTREAM



(SCALE: 1"=2,000')

SHEET: EXH-4	<h1>200 FM 32</h1> <h2>SAN MARCUS, TEXAS</h2> <h3>USGS MAP</h3>	 <p>EVER ENGINEERING, LLC <small>ADVANCED ENGINEERING & SURVEYING SERVICES</small></p> <p>3201 CHERRY RIDGE DR., STE. A-106 SAN ANTONIO, TX 78230 PHONE: 210.572.9340 FAX: 210.572.9344 TXBPE FIRM #19197 TBPLS FIRM #10174902 EVERENC.COM</p>
DRAWN: VB		
JOB NO.: 22-0106		
DATE: JULY 2022		

Z:\Projects\22\0106\DESIGN\CIVIL\EXHIBITS\EXH 4 - USGS MAP.dwg, 11/18/2022 4:29:52 PM, DWG To PDF.pc3

Edwards Aquifer Viewer Custom Print

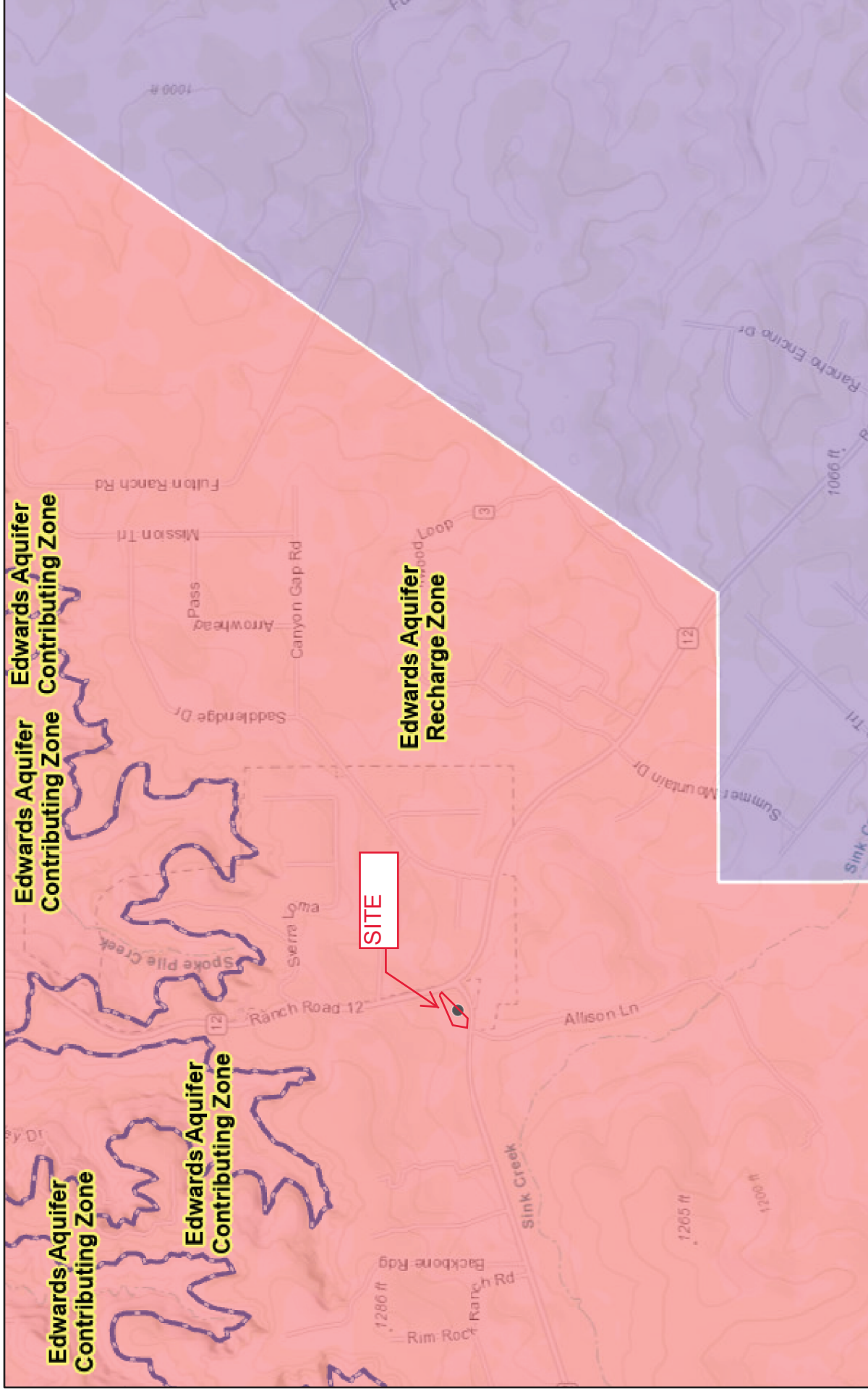

11/18/2022, 4:34:54 PM

- Edwards Aquifer Label
- Edwards Aquifer Boundary
- Edwards Aquifer Boundary central line
- Groundwater Conservation Districts
- Barton Springs/Edwards Aquifer CD
- Edwards Aquifer Authority
- Hays Trinity GCD
- TX Counties
- 7.5 Minute Quad Grid

1:36,112

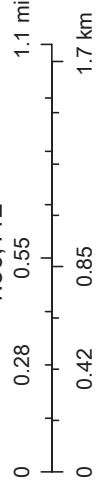

TCEQ, City of Austin, City of Wimberley, Comal County, Texas Parks & Wildlife, Esri, HERE, Garmin, GeoTechnologies, Inc., USGS, METINASA

City of Austin, City of Wimberley, Comal County, Texas Parks & Wildlife, Esri, HERE, Garmin, GeoTechnologies, Inc., USGS, METINASA, EPA, USDA | TCEQ | Web AppBuilder for ArcGIS



EVER ENGINEERING

Advanced Engineering Services

**Section 2: GENERAL INFORMATION FORM (TCEQ-0587)
ATTACHMENT C**

**Savage Land Solutions, LLC.
PROJECT DESCRIPTION**

The Savage Land Solutions project site was previously a food truck park and located in Hays County, within The City of Wimberley ETJ. The property can be described as undeveloped with chain link fence around the perimeter, short grass, and scattered trees with an existing water well and septic tank. On-site slopes widely range from the 1-8%. The proposed property is located at the intersection of Ranch to Market 32 (FM-32), and Ranch Rd 12 (RR-12) as shown on the attached Location Map (EXH 1). The property is a total of 1.8558-acres bound by undeveloped or ranch type lots. The site is located within the Edward's Aquifer Recharge and is subject to the stormwater regulations of the TCEQ.

The proposed project consists of one lot developed for commercial use. Proposed development consists of two commercial buildings totaling approximately 17,064 sf along with associated parking and pavement. This report studies the onsite basin and will show that flows leaving the site for developed conditions will remain the same or lessen from existing conditions due an above ground detention tank.



EVER ENGINEERING

Advanced Engineering Services

Section 3

Savage Land Solutions, LLC.
GEOLOGIC ASSESEMENT FORM (TCEQ-0585)

Geologic Assessment

Texas Commission on Environmental Quality

For Regulated Activities on The Edwards Aquifer Recharge/transition Zones and Relating to 30 TAC §213.5(b)(3), Effective June 1, 1999

To ensure that the application is administratively complete, confirm that all fields in the form are complete, verify that all requested information is provided, consistently reference the same site and contact person in all forms in the application, and ensure forms are signed by the appropriate party.

Note: Including all the information requested in the form and attachments contributes to more streamlined technical reviews.

Signature

To the best of my knowledge, the responses to this form accurately reflect all information requested concerning the proposed regulated activities and methods to protect the Edwards Aquifer. My signature certifies that I am qualified as a geologist as defined by 30 TAC Chapter 213.

Print Name of Geologist: Andrew Silvas

Telephone: 830-816-5434

Date: 9/15/22

Fax: 830-816-5436

Representing: Broadbent & Associates, Inc. TBPG Firm Registration No. 50007 (Name of Company and TBPG or TBPE registration number)

Signature of Geologist:

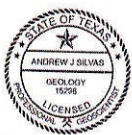

Regulated Entity Name: 200 FM 32 San Marcos, Texas 78666

Project Information

1. Date(s) Geologic Assessment was performed: _____

2. Type of Project:

- WPAP
 SCS

- AST
 UST

3. Location of Project:

- Recharge Zone
 Transition Zone
 Contributing Zone within the Transition Zone

4. **Attachment A - Geologic Assessment Table.** Completed Geologic Assessment Table (Form TCEQ-0585-Table) is attached.
5. Soil cover on the project site is summarized in the table below and uses the SCS Hydrologic Soil Groups* (Urban Hydrology for Small Watersheds, Technical Release No. 55, Appendix A, Soil Conservation Service, 1986). If there is more than one soil type on the project site, show each soil type on the site Geologic Map or a separate soils map.

Table 1 - Soil Units, Infiltration Characteristics and Thickness

Soil Name	Group*	Thickness(feet)
Comfort-Rock outcrop	D	0 to 10
Rumple-Comfort	C	0 to 8.25

* Soil Group Definitions (Abbreviated)

- A. Soils having a high infiltration rate when thoroughly wetted.
- B. Soils having a moderate infiltration rate when thoroughly wetted.
- C. Soils having a slow infiltration rate when thoroughly wetted.
- D. Soils having a very slow infiltration rate when thoroughly wetted.

6. **Attachment B – Stratigraphic Column.** A stratigraphic column showing formations, members, and thicknesses is attached. The outcropping unit, if present, should be at the top of the stratigraphic column. Otherwise, the uppermost unit should be at the top of the stratigraphic column.
7. **Attachment C – Site Geology.** A narrative description of the site specific geology including any features identified in the Geologic Assessment Table, a discussion of the potential for fluid movement to the Edwards Aquifer, stratigraphy, structure(s), and karst characteristics is attached.
8. **Attachment D – Site Geologic Map(s).** The Site Geologic Map must be the same scale as the applicant's Site Plan. The minimum scale is 1": 400'
 Applicant's Site Plan Scale: 1" = 30'
 Site Geologic Map Scale: 1" = 30'
 Site Soils Map Scale (if more than 1 soil type): 1" = 30'
9. Method of collecting positional data:
 - Global Positioning System (GPS) technology.
 - Other method(s). Please describe method of data collection: _____
10. The project site and boundaries are clearly shown and labeled on the Site Geologic Map.
11. Surface geologic units are shown and labeled on the Site Geologic Map.

12. Geologic or manmade features were discovered on the project site during the field investigation. They are shown and labeled on the Site Geologic Map and are described in the attached Geologic Assessment Table.
- Geologic or manmade features were not discovered on the project site during the field investigation.
13. The Recharge Zone boundary is shown and labeled, if appropriate.
14. All known wells (test holes, water, oil, unplugged, capped and/or abandoned, etc.): If applicable, the information must agree with Item No. 20 of the WPAP Application Section.
- There are 1 (#) wells present on the project site and the locations are shown and labeled. (Check all of the following that apply.)
- The wells are not in use and have been properly abandoned.
- The wells are not in use and will be properly abandoned.
- The wells are in use and comply with 16 TAC Chapter 76.
- There are no wells or test holes of any kind known to exist on the project site.

Administrative Information

15. Submit one (1) original and one (1) copy of the application, plus additional copies as needed for each affected incorporated city, groundwater conservation district, and county in which the project will be located. The TCEQ will distribute the additional copies to these jurisdictions. The copies must be submitted to the appropriate regional office.



EVER ENGINEERING

Advanced Engineering Services

**Section 3: GEOLOGICAL ASSESSMENT FORM (TCEQ-0585)
ATTACHMENT A**

**Savage Land Solutions, LLC.
GEOLOGIC ASSESEMENT**

Attachment B
Stratigraphic Column

**SITE SPECIFIC
STRATIGRAPHIC COLUMN**

System	Group	Formation	Function	Member or Informal Unit	Function	Thickness Feet	Lithology	Hydrostratigraphy
Cretaceous	Edwards	Kainer	Aquifer	Dolomitic	AQ	150-200	Limestone, calcified dolomite, and dolomite. Leached, evaporitic rocks with breccias toward top. Dolomite occurs principally in the saline zone of the aquifer.	Supratidal deposits towards top. Mostly tidal to subtidal deposits below. Very porous and permeable zones formed by boxwork porosity in breccias or by burrowed zones.
			Aquifer	Basal Nodular Bed	CB	40-70	Limestone, hard, dense, clayey; nodular, mottled, stylolitic.	Subtidal deposits. Negligible porosity and permeability.
	Trinity	Glen Rose	Aquifer	Upper Glen Rose	CB	300-400	Limestone, dolomite, shale, and marl. Alternating bed of carbonates and marls. Evaporites and dolomites towards top variable bedding	Supratidal and shoreline deposits towards top. Tidal to subtidal deposits below. Unit has little vertical permeability but has moderate lateral permeability.
			Aquifer	Lower Glen Rose	AQ	200-250	Massive limestone with few thin beds of marl.	Marine deposits. Caprinid reef zones and porous and permeable honeycomb porosity near the base.



AQ - Aquifer

CB - Confining Bed

Attachment C
Site Geology

Site Specific Geology and Soil Characteristics

Approximately 1.8558-Acre Tract

Savage Land Solutions

San Marcos, Texas 78666

Area Geologic Setting

The approximate 1.8558-acre tract located at 200 FM 32, San Marcos, Texas 78666 (Site) is located within the Edwards and Trinity Groups. They were deposited in a sheltered open ocean environment sometime in the early Cretaceous approximately 100 million years ago.

The Edwards Aquifer is the primary source of drinking water for San Antonio and other communities in central Texas. The aquifer is comprised of the Georgetown Limestone Formation within the Washita Group and the Person and Kainer Formations within the Edwards Group. These Formations consist of porous and permeable limestone deposits, which are conducive to groundwater flow and storage.

The Site is located within the Balcones Fault Zone, which separates the Edwards Plateau from the Gulf Coastal Plain physiographic province. The Balcones Fault Zone is comprised of a series of steep angle, normal faults that generally strike northeast-southwest. Active movement in the Balcones Fault Zone ceased during the Miocene Epoch. The faulting combined with the exposed lithology of the upper Cretaceous, causes abrupt changes in rock and soil units within the Balcones Fault Zone.

Field observations coincide with descriptions of the Kainer Formation and Glen Rose Formation found in Geologic Framework and Hydrostratigraphy of the Edwards and Trinity Aquifers Within Northern Bexar and Comal Counties, Texas: U.S. Geological Survey Scientific Investigations Map 3366, 1 sheet, scale 1:24,000, pamphlet, <https://doi.org/10.3133/sim3366> by Clark, A.K., Golab, J.A., and Morris, R.R., 2016, indicate the Site is located within the Edwards and Trinity Groups. The Edwards Group is between 410 and 600 feet thick according to the Carbonate Geology and Hydrology of the Edwards Aquifer in the San Antonio Area, Texas by R.W. Maclay and T.A. Small of the U.S. Geological Survey, Austin, Texas 1984. The Edwards lithology consists of limestone, shale, evaporite, and chert. Argillaceous and dolomitic limestones are present (Clark 2016). The Edwards is divided into the Person Formation and the Kainer Formation. The Trinity Group is between 800 and 950 feet thick according to the Carbonate Geology and Hydrology of the Edwards Aquifer in the San Antonio Area, Texas by R.W. Maclay and T.A. Small of the U.S. Geological Survey, Austin, Texas 1984. The Trinity lithology consists of limestone, dolomite, shale, evaporite, and marl. Argillaceous limestones and sandstones are present (Clark 2016). The Trinity is divided into the Glen Rose Formation and the Pearsall Formation.

The intense faulting and fracturing of the limestone in the Balcones Fault Zone, and the varying ability of minerals to be dissolved by groundwater, lead to the formation of the geologic features that are mapped within the Edwards Aquifer Recharge Zone. The combination of faulting, fracturing, rock dissolution, mineral deposition, erosion, and geologic time produce caves, non-karst closed depressions, fractured rock outcrops, Fault Zones, solution cavities, and vugular rock features which are mapped during a Geologic Assessment. The characteristics and physical settings of these geologic features are described to assign a relative infiltration rate and potential recharge ranking to assist in managing the resource of the Edwards Aquifer.

The Site is located within the Edwards Aquifer Recharge Zone according to the information provided by the Edwards Aquifer Map Viewer by the Texas Commission on Environmental Quality, and Edwards Aquifer Recharge Zone and Contributing Zone Map, Edwards Aquifer Authority Rule Chapter 713 by Sarah Eason,

Texas Water Development Board, 2014. Therefore, a Geologic Assessment was conducted in accordance with Title 30 of the Texas Administration Code (TAC) Chapter 213.

Site Geology

The Site is located within the Glen Rose Formation of the Trinity Group and the Kainer Formation of the Edwards Group (Clark, 2016). The Glen Rose Formation is not considered within the Edwards Aquifer, but the Edwards Group is considered within the Edwards Aquifer. The section of the property located within the Edwards group is in the southwest corner and makes up approximately 0.026 acres of the property. No outcrops were observed on-Site.

During the field survey three manmade features in bedrock were observed on-Site. MB-1 is a sewage system located in the northeast portion of the Site. MB-2 is a water well located in the southwest portion of the Site. MB-3 is a 7-foot by 6-foot man made ditch to the southwest of the Site. Photograph documentation of the described features are presented at the end of this section.

Site Soil Characteristics

The Site soil is comprised of Comfort-Rock outcrop complex (CrD) which ranges in thickness between 0 to 10 feet, and the Rumble-Comfort (RUD) ranging in thickness between 0 to 8.25 feet according to the Web Soil Survey of Hays County, Texas, by the United States Department of Agriculture (USDA), 2021. The major soil units of CrD and RUD are class C and D soils as defined in Appendix B, Urban Hydrology for Small Watersheds, by the USDA, Natural Resources Conservation Service, Conservation Engineering Division, Technical Release 55, June, 1986.

Assessment

In general, there is a low potential for fluid movement from the surface of the Site to the Edwards Aquifer due to the low percentage of rock outcroppings, the slow to very slow characteristic of fine textured Group C soil and clay and Group D soil, the lack of connection between the features and the subsurface, and a general lack of sensitive features observed relative to the approximate 1.8558-acre assessment. During the assessment, several ground obstructions were encountered preventing the full assessment of natural geologic conditions. The water well, feature MB-2, has been determined to be a sensitive feature due to the unknown nature of construction and current condition. Broadbent and Associates, Inc. recommends the well be abandoned prior to construction activities.

GEOLOGIC ASSESSMENT PHOTOGRAPHS
Approximately 1.8558-Acre Tract
Savage Land Solutions
San Marcos, Texas 78666



Photograph 1: Northwest facing view of the septic system feature MB-1.



Photograph 2: West facing view of the water well feature MB-2



Photograph 3: North facing view of the water well feature MB-2.



Photograph 4: North facing view of ground obstruction.



Photograph 5: North facing view of feature MB-3.



Photograph 6: West facing view of ground obstruction.



Photograph 7: West facing view of ground obstruction.



Photograph 8: West facing view of ground obstruction.

Attachment D
Site Geologic Maps

Legend	
RUD	Rumble-Confort
CRD	Confort-Rock outcrop complex
● MB-1	Mammade feature in bedrock
—	Estimated Geologic Contact

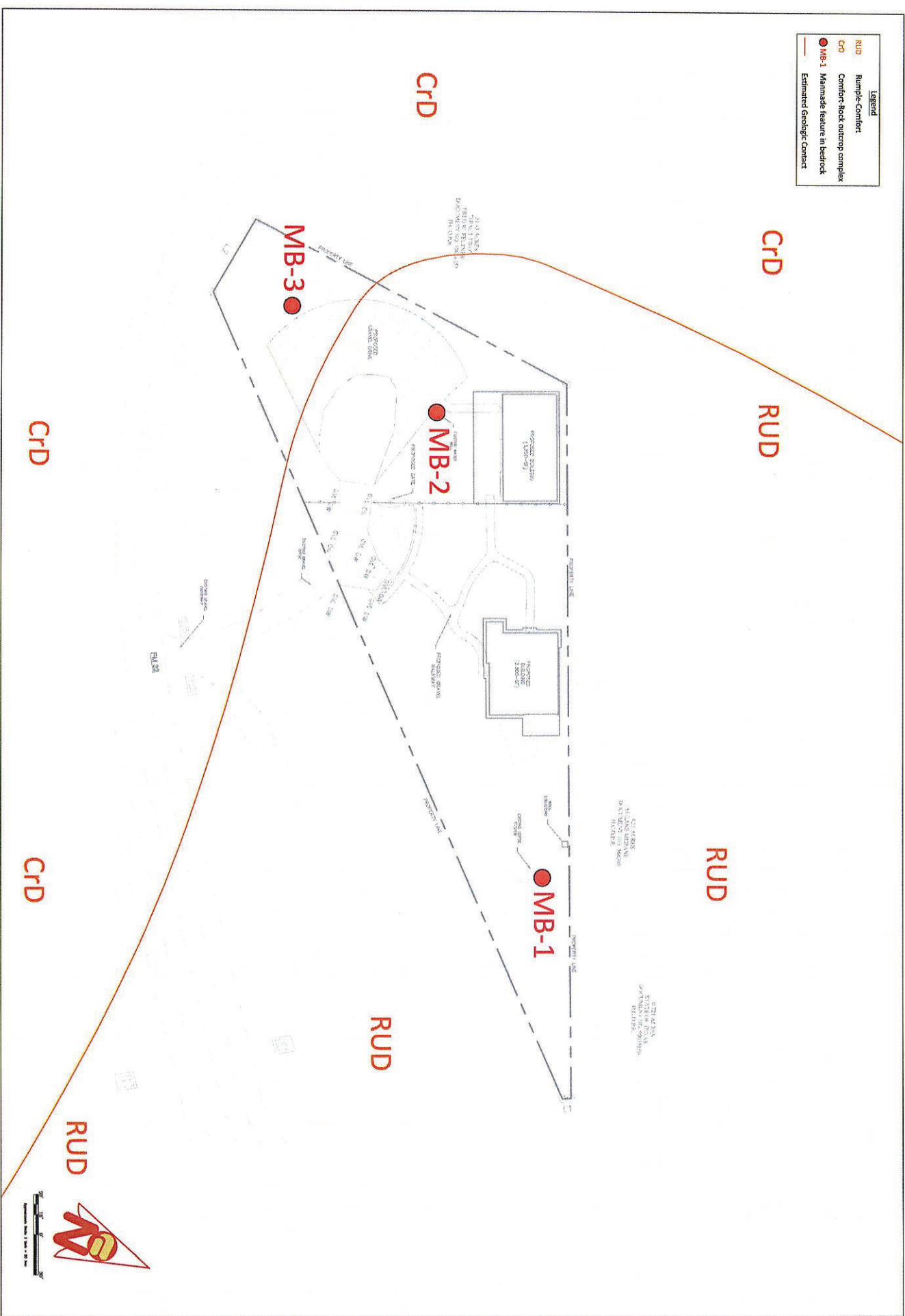

	SOIL MAP GEOLOGIC ASSESSMENT 200 FM 32 SAN MARCOS, TEXAS 78666	CHECKED BY: A.S. DATE: 10/20/17	DRAWN BY: T.S. DATE: 10/20/17	PROJECT NUMBER: 20-01-13-17-07 SCALE: 1" = 20' BROADBENT 113 FALLS COURT, SUITE 700 BISHOP, TEXAS 78606 (830) 816-8454 (F) (830) 816-5436 (F) TBPG FIRM REGISTRATION NO. 50007 COPYRIGHT © 2017 BY BROADBENT & ASSOCIATES, INC. ALL RIGHTS RESERVED.	SAVAGE LAND SOLUTIONS PO BOX 1113 SAN MARCOS, TX 78667	<table border="1"> <thead> <tr> <th>REV</th> <th>DATE</th> <th>BY</th> <th>DESCRIPTION</th> </tr> </thead> <tbody> <tr><td> </td><td> </td><td> </td><td> </td></tr> <tr><td> </td><td> </td><td> </td><td> </td></tr> <tr><td> </td><td> </td><td> </td><td> </td></tr> <tr><td> </td><td> </td><td> </td><td> </td></tr> <tr><td> </td><td> </td><td> </td><td> </td></tr> <tr><td> </td><td> </td><td> </td><td> </td></tr> <tr><td> </td><td> </td><td> </td><td> </td></tr> <tr><td> </td><td> </td><td> </td><td> </td></tr> <tr><td> </td><td> </td><td> </td><td> </td></tr> <tr><td> </td><td> </td><td> </td><td> </td></tr> </tbody> </table>	REV	DATE	BY	DESCRIPTION																																								
	REV	DATE	BY	DESCRIPTION																																														
FIGURE 2																																																		



EVER ENGINEERING
Advanced Engineering Services

Section 4

Savage Land Solutions, LLC.
WATER POLLUTION ABATEMENT PLAN APPLICATION FORM (TCEQ-0584)

Water Pollution Abatement Plan Application

Texas Commission on Environmental Quality

for Regulated Activities on the Edwards Aquifer Recharge Zone and Relating to 30 TAC §213.5(b), Effective June 1, 1999

To ensure that the application is administratively complete, confirm that all fields in the form are complete, verify that all requested information is provided, consistently reference the same site and contact person in all forms in the application, and ensure forms are signed by the appropriate party.

Note: Including all the information requested in the form and attachments contributes to more streamlined technical reviews.

Signature

To the best of my knowledge, the responses to this form accurately reflect all information requested concerning the proposed regulated activities and methods to protect the Edwards Aquifer. This **Water Pollution Abatement Plan Application Form** is hereby submitted for TCEQ review and Executive Director approval. The form was prepared by:

Print Name of Customer/Agent: Gerardo Villarreal

Date: 1/13/23

Signature of Customer/Agent:



Regulated Entity Name: Savage Land Solutions

Regulated Entity Information

1. The type of project is:

- Residential: Number of Lots: _____
- Residential: Number of Living Unit Equivalents: _____
- Commercial
- Industrial
- Other: _____

2. Total site acreage (size of property): 1.855

3. Estimated projected population: N/A

4. The amount and type of impervious cover expected after construction are shown below:

Table 1 - Impervious Cover Table

Impervious Cover of Proposed Project	Sq. Ft.	Sq. Ft./Acre	Acres
Structures/Rooftops	Exempt	÷ 43,560 =	
Parking	17,064	÷ 43,560 =	0.39
Other paved surfaces		÷ 43,560 =	
Total Impervious Cover		÷ 43,560 =	

Total Impervious Cover 0.39 ÷ **Total Acreage** 1.855 X 100 = 28.5% Impervious Cover

5. **Attachment A - Factors Affecting Surface Water Quality.** A detailed description of all factors that could affect surface water and groundwater quality that addresses ultimate land use is attached.
6. Only inert materials as defined by 30 TAC §330.2 will be used as fill material.

For Road Projects Only

Complete questions 7 - 12 if this application is exclusively for a road project.

7. Type of project:

- TXDOT road project.
- County road or roads built to county specifications.
- City thoroughfare or roads to be dedicated to a municipality.
- Street or road providing access to private driveways.

8. Type of pavement or road surface to be used:

- Concrete
- Asphaltic concrete pavement
- Other: _____

9. Length of Right of Way (R.O.W.): _____ feet.

Width of R.O.W.: _____ feet.

L x W = _____ Ft² ÷ 43,560 Ft²/Acre = _____ acres.

10. Length of pavement area: _____ feet.

Width of pavement area: _____ feet.

L x W = _____ Ft² ÷ 43,560 Ft²/Acre = _____ acres.

Pavement area _____ acres ÷ R.O.W. area _____ acres x 100 = _____% impervious cover.

11. A rest stop will be included in this project.
- A rest stop will not be included in this project.

12. Maintenance and repair of existing roadways that do not require approval from the TCEQ Executive Director. Modifications to existing roadways such as widening roads/adding shoulders totaling more than one-half (1/2) the width of one (1) existing lane require prior approval from the TCEQ.

Stormwater to be generated by the Proposed Project

13. **Attachment B - Volume and Character of Stormwater.** A detailed description of the volume (quantity) and character (quality) of the stormwater runoff which is expected to occur from the proposed project is attached. The estimates of stormwater runoff quality and quantity are based on the area and type of impervious cover. Include the runoff coefficient of the site for both pre-construction and post-construction conditions.

Wastewater to be generated by the Proposed Project

14. The character and volume of wastewater is shown below:

<u>100</u> % Domestic	<u>200</u> Gallons/day
<u> </u> % Industrial	<u> </u> Gallons/day
<u> </u> % Commingled	<u> </u> Gallons/day
TOTAL gallons/day <u>200</u>	

15. Wastewater will be disposed of by:

On-Site Sewage Facility (OSSF/Septic Tank):

Attachment C - Suitability Letter from Authorized Agent. An on-site sewage facility will be used to treat and dispose of the wastewater from this site. The appropriate licensing authority's (authorized agent) written approval is attached. It states that the land is suitable for the use of private sewage facilities and will meet or exceed the requirements for on-site sewage facilities as specified under 30 TAC Chapter 285 relating to On-site Sewage Facilities.

Each lot in this project/development is at least one (1) acre (43,560 square feet) in size. The system will be designed by a licensed professional engineer or registered sanitarian and installed by a licensed installer in compliance with 30 TAC Chapter 285.

Sewage Collection System (Sewer Lines):

Private service laterals from the wastewater generating facilities will be connected to an existing SCS.

Private service laterals from the wastewater generating facilities will be connected to a proposed SCS.

The SCS was previously submitted on _____.

The SCS was submitted with this application.

The SCS will be submitted at a later date. The owner is aware that the SCS may not be installed prior to Executive Director approval.

The sewage collection system will convey the wastewater to the _____ (name) Treatment Plant. The treatment facility is:

Existing.

Proposed.

16. All private service laterals will be inspected as required in 30 TAC §213.5.

Site Plan Requirements

Items 17 – 28 must be included on the Site Plan.

17. The Site Plan must have a minimum scale of 1" = 400'.

Site Plan Scale: 1" = 30 '.

18. 100-year floodplain boundaries:

Some part(s) of the project site is located within the 100-year floodplain. The floodplain is shown and labeled.

No part of the project site is located within the 100-year floodplain.

The 100-year floodplain boundaries are based on the following specific (including date of material) sources(s): _____

19. The layout of the development is shown with existing and finished contours at appropriate, but not greater than ten-foot contour intervals. Lots, recreation centers, buildings, roads, open space, etc. are shown on the plan.

The layout of the development is shown with existing contours at appropriate, but not greater than ten-foot intervals. Finished topographic contours will not differ from the existing topographic configuration and are not shown. Lots, recreation centers, buildings, roads, open space, etc. are shown on the site plan.

20. All known wells (oil, water, unplugged, capped and/or abandoned, test holes, etc.):

There are 1 (#) wells present on the project site and the locations are shown and labeled. (Check all of the following that apply)

The wells are not in use and have been properly abandoned.

The wells are not in use and will be properly abandoned.

The wells are in use and comply with 16 TAC §76.

There are no wells or test holes of any kind known to exist on the project site.

21. Geologic or manmade features which are on the site:

All sensitive geologic or manmade features identified in the Geologic Assessment are shown and labeled.

No sensitive geologic or manmade features were identified in the Geologic Assessment.

Attachment D - Exception to the Required Geologic Assessment. A request and justification for an exception to a portion of the Geologic Assessment is attached.

- 22. The drainage patterns and approximate slopes anticipated after major grading activities.
- 23. Areas of soil disturbance and areas which will not be disturbed.
- 24. Locations of major structural and nonstructural controls. These are the temporary and permanent best management practices.
- 25. Locations where soil stabilization practices are expected to occur.
- 26. Surface waters (including wetlands).
 N/A
- 27. Locations where stormwater discharges to surface water or sensitive features are to occur.
 There will be no discharges to surface water or sensitive features.
- 28. Legal boundaries of the site are shown.

Administrative Information

- 29. Submit one (1) original and one (1) copy of the application, plus additional copies as needed for each affected incorporated city, groundwater conservation district, and county in which the project will be located. The TCEQ will distribute the additional copies to these jurisdictions. The copies must be submitted to the appropriate regional office.
- 30. Any modification of this WPAP will require Executive Director approval, prior to construction, and may require submission of a revised application, with appropriate fees.



EVER ENGINEERING
Advanced Engineering Services

**Section 4: WATER POLLUTION ABATEMENT APPLICATION FORM (TCEQ-0584)
ATTACHMENT A**

Savage Land Solutions, LLC.
FACTORS AFFECTING SURFACE WATER QUALITY

Attachment A – Factors Affecting Surface Water Quality

Factors affecting surface water quality include impervious cover from rooftops and paved parking areas. Impervious cover from rooftops will be mitigated by collecting the runoff into a gutter system leading to a water tank. Water collected from the rooftops will be utilized for onsite irrigation and non-potable water. Therefore, runoff from rooftops is not included with impervious calculations in this report. Paved parking areas will also affect surface water quality. A detailed impervious cover exhibit is attached to this report and shows the ultimate developed condition of the site



EVER ENGINEERING
Advanced Engineering Services

**Section 4: WATER POLLUTION ABATEMENT APPLICATION FORM (TCEQ-0584)
ATTACHMENT B**

Savage Land Solutions, LLC.
VOLUME AND CHARACTER OF STORM WATER

The 1.855-acre project site is part of a larger 3.19-acre drainage analysis that includes 1 watershed (Onsite WS-1). In both both existing and proposed condition, storm water will flow east.

As mentioned, stormwater exiting the site generally flow towards the east. On-site stormwater will eventually outfall into sink creek leading to the San Marcos River, TCEQ Segment No. 1814. Stormwater runoff leaving the site will be detained by an above ground tank.

Attachment B – Volume and Character of Stormwater

Runoff Volume:

Watershed	Area (ac)	C (unitless)	Tc (min)	Flow (cfs)			
				2	10	25	100
EXISTING							
ONSITE WS-1	3.19	0.57	11	8.86	12.59	14.98	18.64
ULTIMATE/DEVELOPED							
ONSITE WS-1	3.19	0.60	11	9.32	13.25	15.77	19.62
ROOFTOPS	0.22	0.99	5	1.37	1.99	2.37	2.97
ONSITE WS-1 POST DETENTION	2.97	0.60	11	7.95	11.26	13.40	16.65

Water Quality volume:

Onsite Water Quality Volume: 1,139 CF

Offsite Water Quality Volume: 65 CF

Total Capture Volume (required WQ volume x 1.20) = 1,445 CF



EVER ENGINEERING

Advanced Engineering Services

**Section 4: WATER POLLUTION ABATEMENT APPLICATION FORM (TCEQ-0584)
ATTACHMENT C**

Savage Land Solutions, LLC.
SUITABILITY LETTER FROM AUTHORIZED AGENT
(if OSSF is proposed)

Environmental Concepts, LLC

Kyle B. DeHart, RS, SE * RS#4127 * SE#22979 * 512-847-8388



On-Site Sewage Facility (OSSF) Design and Calculations

For: Junction Truck Yard, 200 FM 32, San Marcos, TX 78666

MBS
5/3/18

Site Description

The site is approximately 1.85 acres located in Hays County. The soil evaluation indicates Class IV soils down to 13" followed by Class III soils down to 38". This site is suitable for an Aerobic Drip system. The site is slightly sloping with native oak and cedar trees along with native grasses present. The drip lines will be placed on top of 6"-8" of Class III soil that is put on the Class IV soil, after scarification has taken place. A Well is present on the site and more than 150' from the dripfield. No other Wells or recharge features were observed within 150'. A TCEQ approved potable water tank is proposed for the toilets and hand sinks.

System Design

The location will contain 4 sites for self-contained food trucks and a bar that will serve draft and bottled beer. A restroom structure containing two restrooms will also be present. The bar will utilize single-serve cups for draft beer. There are water saving fixtures proposed. The projected daily wastewater flow is 200gpd, per owner request. Water flow figured at 45 customers a day @ 2gpd/customer for restroom use and 1 employee @ 15gpd/emp. (flows determined from Table 2.4 "Overview of Advanced Wastewater Treatment Systems", Bars). The location will be open on Thursday thru Sunday.

revision

A Maxx-Air Aerobic Treatment Unit M-800 (800gpd ATU) will be utilized after the 1500 gallon 2-chamber trash/dose tank. The 1500 gallon 2-chamber tank will be precast with the inlet & outlet chambers reversed to allow for a 600 gallon trash chamber followed by a 900 gallon dose chamber. The outlet of the 900 gallon dose chamber will be connected to the trash chamber of the 1st compartment of the ATU, via 3" or 4" Sch40 PVC pipe and act as an overflow to the 1st compartment of the trash chamber of the ATU should a pump failure occur. A 1.0" PVC line will also be used on the dosing pump in the 900 gallon dosing chamber to the ATU trash chamber.

INSTALL PRESSURE GAUGE AND FLOW METER

The Maxx-Air M-800 ATU is a 3 chamber concrete tank and composed of steel reinforced concrete. It consists of a 431 gallon pretreatment/trash chamber that flows by gravity into the 947 gallon combined aerobic/clarifying chambers. Once the effluent has settled and is processed it gravity flows from the aerobic/clarifying chambers to the 854 gallon pump chamber where it is stored for drip dispersal.

It will then be dispersed through a 120 mesh disc filter and a 40psi pressure regulator to the drip field by a 1.0" Sch40 PVC supply line. Continuous return flushing will be utilized via the 1.0" Sch40 PVC return line to the pump chamber. The return line to the pump chamber will be set to 10psi via a pressure gauge and a gate or ball valve installed on the return line manifold. Once at the drip field, the effluent will flow into the drip lines and be evenly dispersed into the field. The effluent will then continue to be processed by bacteria in the soil and dissipated by absorption and evapotranspiration.

Design Specifications & Capacities

Wastewater daily flow (Q): 45 customers @ 2gpd + 1 emp. @ 15gpd = 105gpd (design = 200gpd)

Required drainfield area (A=Q/Ra): 200gpd(Q)/.10gpd/sq.ft. = 2000sq.ft. (A)

Emitters: 2000sq.ft./4sq.ft. per emitter = 500 emitters.

Length of drip line required: 500 emitters x 2' spacing/emitter = 1000' drip line. (Netafim Bioline)

Actual drip line length: Loop 1 = 284', Loop 2 = 242', Loop 3 = 258', Loop 4 = 224' Total = 1008'.

Drip bed specifications: The drip field is to follow the natural contours of the land with the lines placed on top of 6"-8" of Loam type backfill and then covered with 8"-10" of Loam type soil.

NuWater Tank: Trash: 353gal. Aerobic/Clarifier: 750gal. (600gpd) **Pump Chamber:** 768gal.

Dosing Chamber Specifications (1500 Gallon 2-Comp Tank)

Dosing Chamber: 900 gallon chamber contained in a 2 compartment 1500 gallon tank. (24.32gal/inch)

Friction loss: 4.0' of 1.5" PVC @ ~40gpm = (4.0'/100' x 8.90') x 1.2 for fittings = .43'

Elevation: 5.0' rise from pump to ATU inlet.

Total Dynamic Head: .43' + 5.0' = 5.43'.

*seed
* Curlex
* WATER SOFTENER

Dosing Chamber Specifications(cont'd)

Pump: Barnes SP33 (1/3hp pump)

Pump off: @ 6.0"

Pump on: @ 9.0"

Storage Capacity: = 462.08gal.

Alarm on: @ 28.0" above floor. 900.0gal. – 680.96gal = 219.04gal reserve.

Dosed Capacity: Dosed for .5 minute (30seconds) @ ~ 20 gallons, every 144 minutes, via a Rhombus Type EZS control panel with 2 floats (no redundant off or override). (20gal/2.4hr x 24hr = 200gpd)

WFB/MS
5/3/18



Pump Calculations and Float Settings (854 Gallon Pump Chamber)

Friction Loss Supply: 110' of 1" Sch40 PVC @ 11.44gpm = (110'/100' x 7.69') x 1.2 for fittings = 10.15'

Friction Loss Return: 90' of 1" Sch40 PVC @ 6.4gpm = (90'/100' x 2.13') x 1.2 for fittings = 2.30'.

Elevation: 6.0' rise from pump to top of tank = 6.0'

Dripper Line Loss: 284' longest loop = 31.0'

Filter Loss: 10.0' @ 120 mesh (100 micron) disc filter.

Total Dynamic Head (TDH): 10.15' + 2.30' + 6.0' + 31.0' + 10.0' = 59.45' (25.73psi).

Dosing Volume: 504 emitters @ .01gpm = 5.04gpm dose rate. 200gpd/5.04gpm = ~40.0mins. total dose.

Dose@50gal/dose = 4 doses/day @ 10min/dose. Timer set to dose every 6 hours @ 10min/dose.

Pump Requirements: 5.04gpm + 6.4gpm (4 x 1.6gpm for backflush in return line) = 11.44gpm.

Pump: Franklin C-Series 1/2hp (23gpm @ 30psi)

Pump Chamber: 854 gallon chamber with 53.0" usable storage = 16.11gal/inch

Pump on @ 12.0" above floor.

Pump off @ 8.0" above floor.

Working Capacity: = 201.37gal.

Alarm on @ 24.5" above floor. 854.0gal. – 394.70gal = 459.30gal reserve.

Effluent flow meter: Netafim Model ARABM1EV1U, Part # 70261-002720. (Austin Septic Supply)

Revision

BOD Calculations

Since there is no kitchen or commercial type waste at this location, the BOD at this location will be similar to residential strength BOD and will result in a waste strength of less than 140mg/l to drainfield.

Please note, it will be required that all spilled and left over beer will not be put into the OSSF. All such spillage will be collected and put into the trash.

Installation & Construction

The installer is to follow all guidelines and setbacks as imposed by the TCEQ Chapter 285 and the local Regulatory Authority all times. Call the local Regulatory Authority for Installation Inspection Requirements.

Once the tank hole is dug a minimum of 4 inches of sand, sandy loam, or pea gravel must be placed as a leveling pad under the tank. Backfill for the tank must not contain rocks or be a Class IV type soil. The tank hole containing the water filled tank is to be left open until the tank has been inspected by the Regulatory Authority.

There should be a minimum of 1/8" per foot of fall in the tightline from the structures to the tank. A 2-way cleanout will be installed between the structures and the tank.

Sleeve tightline @ water line crossing to 10' either side and seal the ends of sleeve pipe. Sleeve the tightline within 5' of any surface improvement.

The dripfield shall contain 4 loops of Bioline Netafim drip tubing. Loop 1 = 284', Loop 2 = 242', Loop 3 = 258', Loop 4 = 224' Total of 1008'. Drip lines will be placed on top of 6"-8" of Class II or III Loam type soil.

Automatic flush return line will re-enter the pump chamber through the riser at the pump chamber.

A 40psi Pressure regulator and 120 mesh filter is required between the supply line and the drip field. A pressure gauge and valve are required on the return line before it enters the pump chamber. These can all be contained in the riser or the valve box.

The drip tubing will be covered with 8" – 10" of Class II or III Loam type soil.

The Junction Truck Yard

200 FM 32
San Marcos, TX 78666

RR 12

Scale:
1" = 60'

- Sleeve 2" line 10' either side and seal ends at water line crossing.
- Sleeve 2" line 5' either side and within 5' of surface improvements.
- 2-way cleanouts at structure stub-outs
- Drip field to contain a minimum of 1000' of drip line within 4 loops.
- Loop 1 = ~284', Loop 2 = ~242', Loop 3 = ~258', Loop 4 = ~224'
(total length = ~ 1008')
- Drip lines to run between or around oak trees as needed.
- Drip components can be housed in the riser or a valve box.
- R = return line
- S = supply line
- O = vacuum breakers at high contour of R & S lines.
- P = profile hole

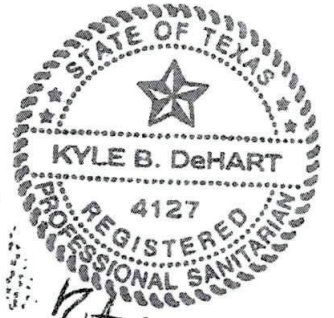
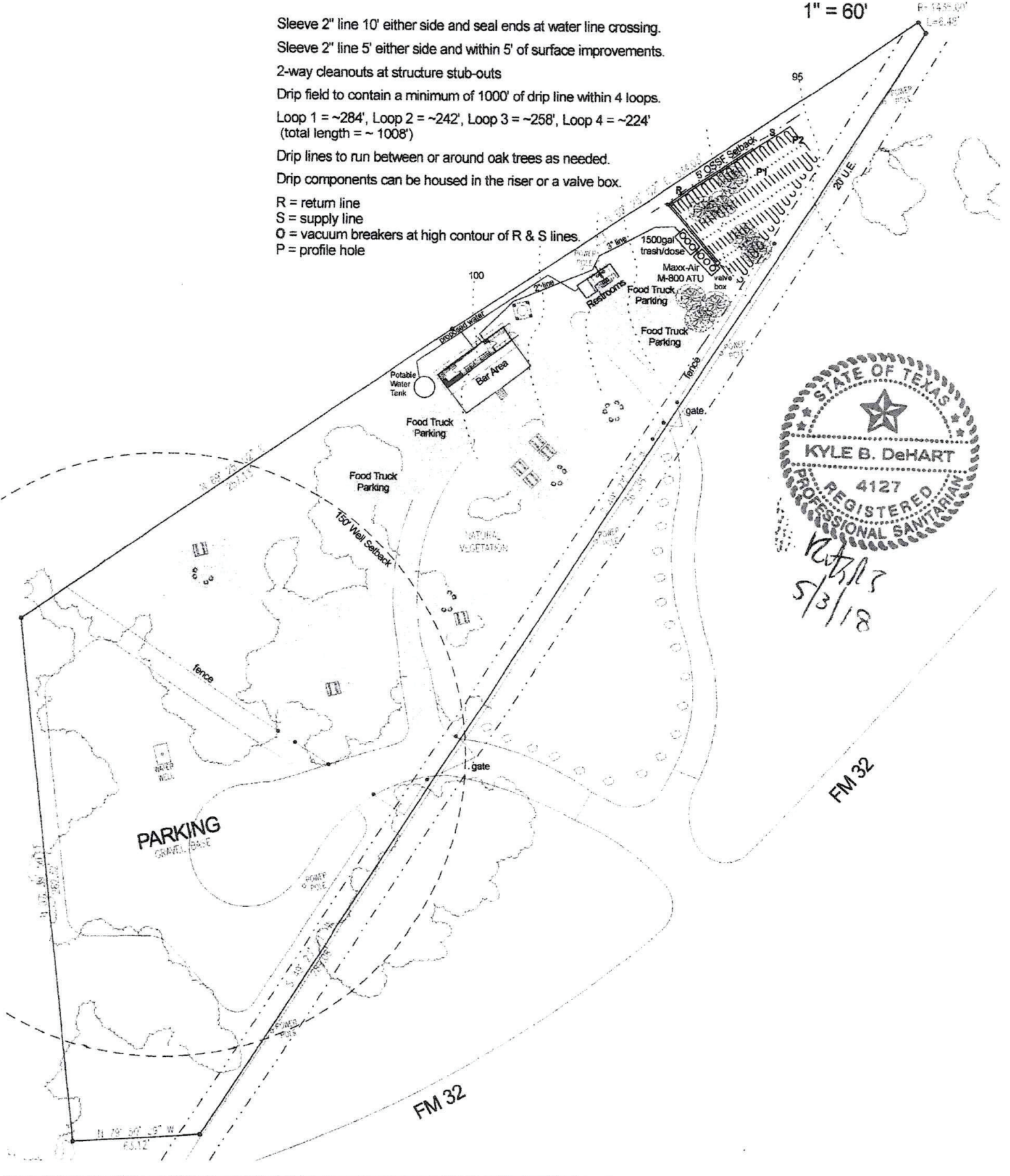

Handwritten:
KBD
5/3/18

FM 32

FM 32

N 78° 50' 39" W
R.S.12

Assembly Details

OSSF

DIMENSIONS:
 Outside Height: 67"
 Outside Width: 75"
 Outside Length: 164.5"
MINIMUM EXCAVATION DIMENSIONS:
 Width: 87"
 Length: 177"

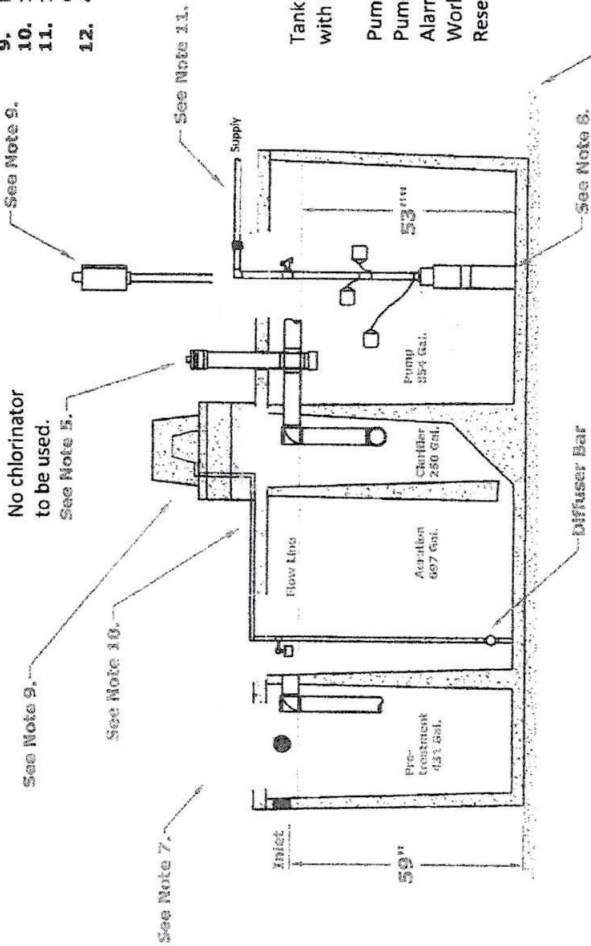

GENERAL NOTES:

1. Plant structure material to be precast concrete and steel.
2. Maximum burial depth is 30" from slab top to grade.
3. Weight = 16,700 lbs.
4. Treatment capacity is 800 GPD. Pump compartment set-up for a 420 GPD Flow Rate (5 bedroom, < 4,501 sq/ft living area). Please specify for additional set-up requirements.
5. Standard tablet chlorinator or Optional Liquid chlorinator. NSF approved chlorinators (tablet & liquid) available.
6. Bio-Robix B-800 Control Center w/ Timer for night spray application. Optional Micro Dose (min/sec) timer available for drip applicators. Electrical Requirement to be 115 Volts, 60 Hz, Single Phase, 30 AMP, Grounded Receptacle.
7. 20" Ø access riser w/ lid (Typical 4). Optional extension risers available.
8. 20 GPM 1/2 HP, high head effluent pump.
9. HIBLOW Air Compressor w/ concrete housing.
10. 1/2" Sch. 40 PVC Air Line (Max. 50 Lft from Plant).
11. 1" Sch. 40 PVC pipe to distribution system provided by contractor.
12. 4" min. compacted sand or gravel pad by Contractor



Tank to have risers and lids to grade with secondary lid or plug in place

Pump off @ 8.0"
 Pump on @ 12.0"
 Alarm on @ 24.5"
 Working capacity = 201.37gal
 Reserve capacity = 459.30gal

Advantage
 Advantage Wastewater Solutions Inc.
 444 A Old Hwy No 9
 Comfort, TX 76013
 830-995-3189
 fax 830-995-4051

March, 2010
 By: A.S.
 Scale: *All dimensions subject to manufacturer's specification
 DWG. #: ADY-8800-2

Maxx-Air M-800 (800gpd)
Aerobic Treatment Plant (Assembled)
 Model: M-800

C1 Series Family Curve

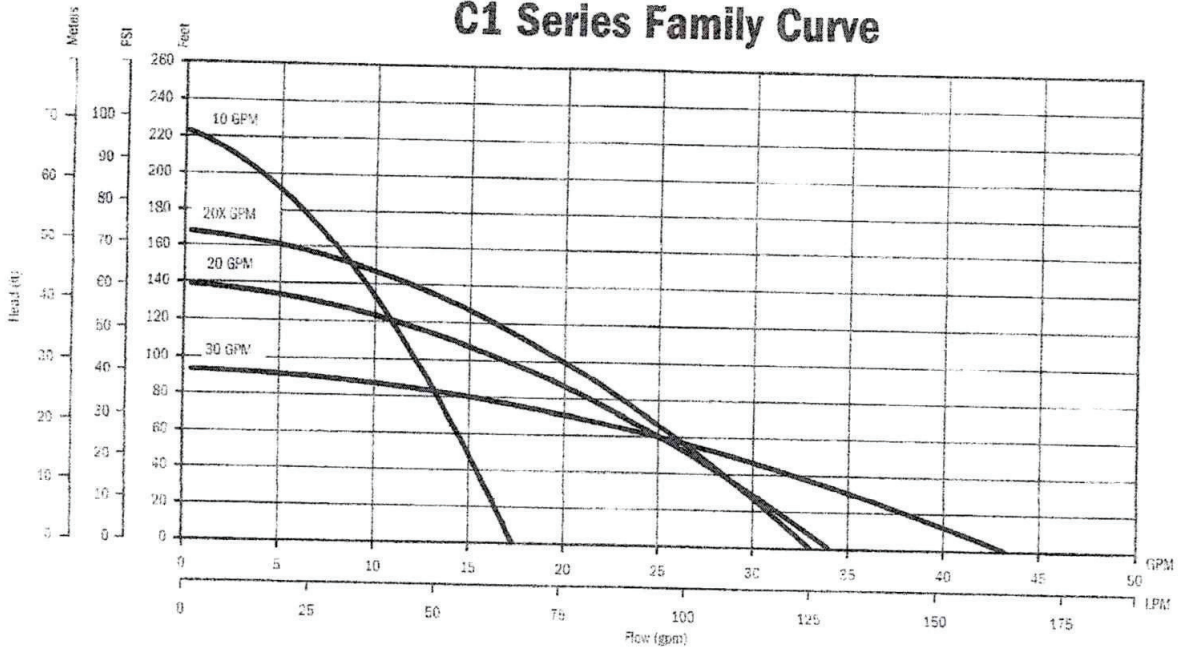

FEATURES

- Supplied with a removable 5" base for secure and reliable mounting
- Bottom suction design
- Robust thermoplastic discharge head design resists breakage during installation and operation
- Single shell housing design provides a compact unit while ensuring cool and quiet operation
- Hydraulic components molded from high quality engineered thermoplastics
- Optimized hydraulic design allows for increased performance and decreased power usage
- All metal components are made of high grade stainless steel for corrosion resistance
- Available with a high quality 115 V or 230 V, 1/2 hp motor
- Fluid flows of 10, 20, and 30 gpm, with a max shut-off pressure of over 100 psi
- Heavy duty 600 V 10 foot SJ00W jacketed lead

APPLICATIONS

- Gray water pumping
- Filtered effluent service water pumping
- Water reclamation projects such as pumping from rain catchment basins
- Aeration and other foundation or pond applications
- Agriculture and livestock water pumping

ORDERING INFORMATION

C1 Series Pumps							
GPM	HP	Volts	Stage	Model No.	Order No.	Length (in)	Weight (lbs)
10	1/2	115	7	10C1-05P4-2W115	90301005	26	17
		230	7	10C1-05P4-2W230	90301010	26	17
20		115	5	20C1-05P4-2W115	90302005	25	16
		230	5	20C1-05P4-2W230	90302010	25	16
20X		115	6	20XC1-05P4-2W115	90302015	26	17
		230	6	20XC1-05P4-2W230	90302020	26	17
30		115	4	30C1-05P4-2W115	90303005	25	16
		230	4	30C1-05P4-2W230	90303010	25	16

Note: All units have 10 foot long SJ00W leads.

Hays County Development Services
Physical Address: 2171 Yarrington Road, San Marcos, TX 78666
Mailing Address: 712 S. Stagecoach Trail, San Marcos, TX 78666
(512) 393-2150 - (512) 493-1915 fax

Authorization to Construct an On-site Sewage Facility
Permit #: 2017-31766

Location: 200 FM 32, SAN MARCOS, TX 78666

Section: Block: Lot:

Owner: 2226 PROPERTIES LLC - THOMAS CATHCART

Mailing Address: PO BOX 1797, SAN MARCOS, TX 78667

AUTHORIZATION IS HEREBY GIVEN TO CONSTRUCT AN ON-SITE SEWAGE FACILITY ON THE ABOVE DESCRIBED PROPERTY.

Approval is hereby granted for the construction as shown on the submitted planning material.

ANY MODIFICATIONS TO SUBMITTED PLANS REQUIRE APPROVAL BY HAYS COUNTY DEVELOPMENT SERVICES PRIOR TO INSTALLATION.

CONTACT HAYS COUNTY DEVELOPMENT SERVICES FOR REQUIRED INSPECTIONS.

This Authorization to Construct is valid for twelve months from the date of issuance.

COMMENTS:

Note: The On-site Sewage Facility construction must meet all TCEQ Regulations and Hays County Rules for On-site Sewage Facilities. If unforeseen and/or adverse conditions are encountered (including, but not limited to excessive rock, seepage, or high water table) stop construction and contact HAYS COUNTY DEVELOPMENT SERVICES. Revised planning materials and Authorization to Construct may be required.



Agency Official

11/21/2017

Date



EVER ENGINEERING
Advanced Engineering Services

**Section 4: WATER POLLUTION ABATEMENT APPLICATION FORM (TCEQ-0584)
ATTACHMENT D**

Savage Land Solutions, LLC.
EXCEPTION TO THE REQUIRED GEOLOGIC ASSESSMENT

This attachment does not apply to this submittal. An exception to the required Geologic Assessment is not required. A Geologic Assessment of the project site was completed and is included in this submittal, see Section 4 of this report.



EVER ENGINEERING
Advanced Engineering Services

**Section 4: WATER POLLUTION ABATEMENT APPLICATION FORM (TCEQ-0584)
ATTACHMENT E**

Savage Land Solutions, LLC.
TCEQ WPAP SITE PLAN



DATE:	DEC. 2022
JOB NO.:	22-0106
CHECKED:	RDM
DRAWN:	GV
TBD:	
PLAN NO.:	

OVERALL SITE PLAN

NO.	DATE	REVISIONS

PROJECT LOCATION:
 200 FM 32
 SAN MARCOS, TEXAS 78666



EVER ENGINEERING, LLC
 ADVANCED ENGINEERING SERVICES
 3201 CHERRY RIDGE DRIVE, SUITE A-106,
 SAN ANTONIO, TX 78230
 OFFICE (210) 572-9340 FAX (210) 572-9344
 WWW.EVERENC.COM, WWW.AES-TX.COM
 FIRM NO. E-19197

SAVAGE LAND SOLUTIONS HQ

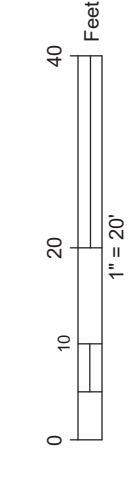
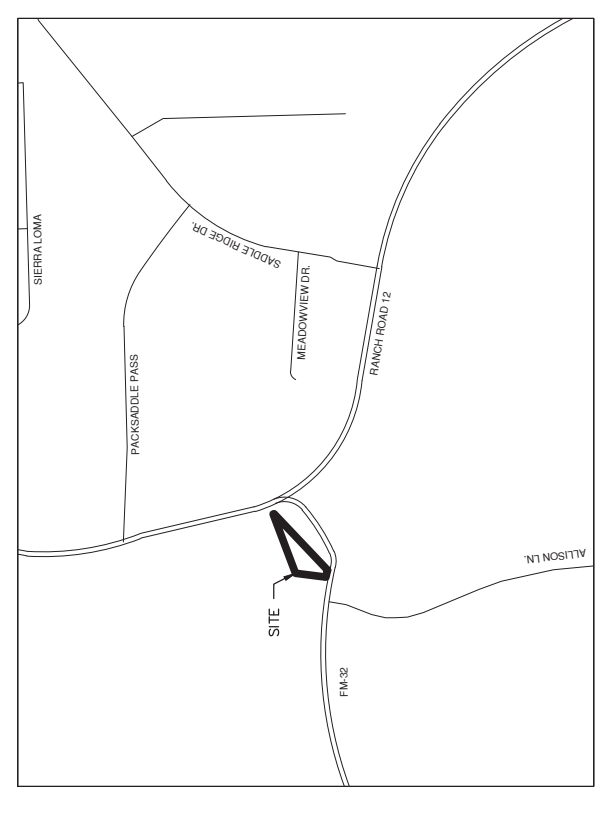

LEGEND

- PROPERTY LINE
- - - ADJACENT PROPERTY LINE
- - - EXISTING EASEMENT
- - - PROPOSED EASEMENT

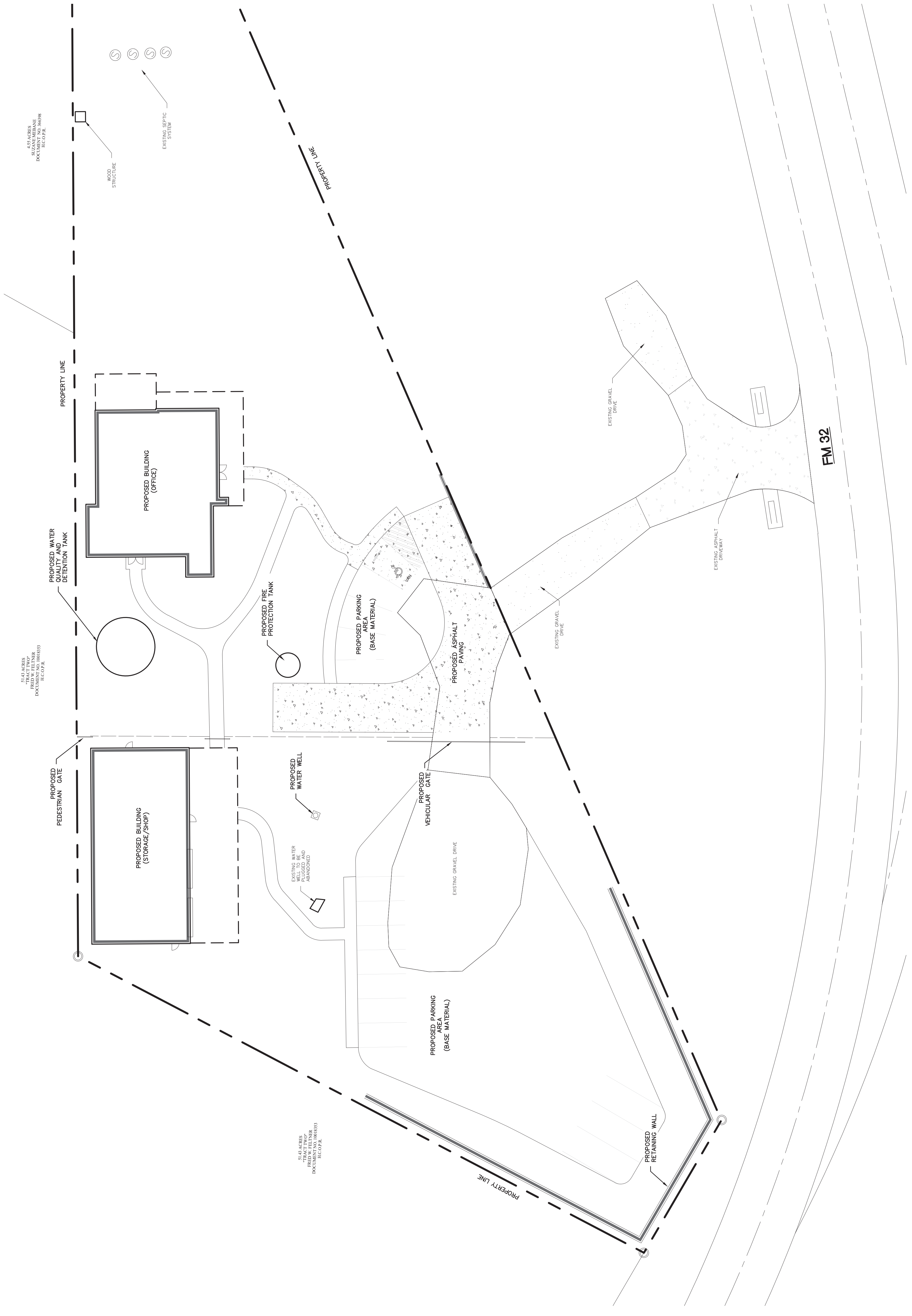

LEGAL DESCRIPTION
 1.8558-ACRE TRACT
 ABS 25
 JAMES ALSTON SURVEY

51.64 ACRES
 FRED W. FLETCHER
 DOCUMENT NO. 109833
 REC. 04/11/04

5.54 ACRES
 SUZANNE BROWN
 DOCUMENT NO. 36088
 REC. 02/21/02

51.64 ACRES
 FRED W. FLETCHER
 DOCUMENT NO. 109833
 REC. 04/11/04

FM 32



EVER ENGINEERING
Advanced Engineering Services

Section 5

Savage Land Solutions, LLC.
TEMPORARY STORM WATER SECTION (TCEQ-0602)

Temporary Stormwater Section

Texas Commission on Environmental Quality

for Regulated Activities on the Edwards Aquifer Recharge Zone and Relating to 30 TAC §213.5(b)(4)(A), (B), (D)(I) and (G); Effective June 1, 1999

To ensure that the application is administratively complete, confirm that all fields in the form are complete, verify that all requested information is provided, consistently reference the same site and contact person in all forms in the application, and ensure forms are signed by the appropriate party.

Note: Including all the information requested in the form and attachments contributes to more streamlined technical reviews.

Signature

To the best of my knowledge, the responses to this form accurately reflect all information requested concerning the proposed regulated activities and methods to protect the Edwards Aquifer. This **Temporary Stormwater Section** is hereby submitted for TCEQ review and executive director approval. The application was prepared by:

Print Name of Customer/Agent: Ever Garza, P.E.

Date: 11/22/2022

Signature of Customer/Agent:



Regulated Entity Name: Savage Land Solutions

Project Information

Potential Sources of Contamination

Examples: Fuel storage and use, chemical storage and use, use of asphaltic products, construction vehicles tracking onto public roads, and existing solid waste.

1. Fuels for construction equipment and hazardous substances which will be used during construction:

The following fuels and/or hazardous substances will be stored on the site: _____

These fuels and/or hazardous substances will be stored in:

- Aboveground storage tanks with a cumulative storage capacity of less than 250 gallons will be stored on the site for less than one (1) year.

- Aboveground storage tanks with a cumulative storage capacity between 250 gallons and 499 gallons will be stored on the site for less than one (1) year.
- Aboveground storage tanks with a cumulative storage capacity of 500 gallons or more will be stored on the site. An Aboveground Storage Tank Facility Plan application must be submitted to the appropriate regional office of the TCEQ prior to moving the tanks onto the project.
- Fuels and hazardous substances will not be stored on the site.
- 2. **Attachment A - Spill Response Actions.** A site specific description of the measures to be taken to contain any spill of hydrocarbons or hazardous substances is attached.
- 3. Temporary aboveground storage tank systems of 250 gallons or more cumulative storage capacity must be located a minimum horizontal distance of 150 feet from any domestic, industrial, irrigation, or public water supply well, or other sensitive feature.
- 4. **Attachment B - Potential Sources of Contamination.** A description of any activities or processes which may be a potential source of contamination affecting surface water quality is attached.

Sequence of Construction

- 5. **Attachment C - Sequence of Major Activities.** A description of the sequence of major activities which will disturb soils for major portions of the site (grubbing, excavation, grading, utilities, and infrastructure installation) is attached.
 - For each activity described, an estimate (in acres) of the total area of the site to be disturbed by each activity is given.
 - For each activity described, include a description of appropriate temporary control measures and the general timing (or sequence) during the construction process that the measures will be implemented.
- 6. Name the receiving water(s) at or near the site which will be disturbed or which will receive discharges from disturbed areas of the project: Tributary of Sink Creek

Temporary Best Management Practices (TBMPs)

Erosion control examples: tree protection, interceptor swales, level spreaders, outlet stabilization, blankets or matting, mulch, and sod. Sediment control examples: stabilized construction exit, silt fence, filter dikes, rock berms, buffer strips, sediment traps, and sediment basins. Please refer to the Technical Guidance Manual for guidelines and specifications. All structural BMPs must be shown on the site plan.

- 7. **Attachment D – Temporary Best Management Practices and Measures.** TBMPs and measures will prevent pollution of surface water, groundwater, and stormwater. The construction-phase BMPs for erosion and sediment controls have been designed to retain sediment on site to the extent practicable. The following information is attached:

- A description of how BMPs and measures will prevent pollution of surface water, groundwater or stormwater that originates upgradient from the site and flows across the site.
 - A description of how BMPs and measures will prevent pollution of surface water or groundwater that originates on-site or flows off site, including pollution caused by contaminated stormwater runoff from the site.
 - A description of how BMPs and measures will prevent pollutants from entering surface streams, sensitive features, or the aquifer.
 - A description of how, to the maximum extent practicable, BMPs and measures will maintain flow to naturally-occurring sensitive features identified in either the geologic assessment, TCEQ inspections, or during excavation, blasting, or construction.
8. The temporary sealing of a naturally-occurring sensitive feature which accepts recharge to the Edwards Aquifer as a temporary pollution abatement measure during active construction should be avoided.
- Attachment E - Request to Temporarily Seal a Feature.** A request to temporarily seal a feature is attached. The request includes justification as to why no reasonable and practicable alternative exists for each feature.
 - There will be no temporary sealing of naturally-occurring sensitive features on the site.
9. **Attachment F - Structural Practices.** A description of the structural practices that will be used to divert flows away from exposed soils, to store flows, or to otherwise limit runoff discharge of pollutants from exposed areas of the site is attached. Placement of structural practices in floodplains has been avoided.
10. **Attachment G - Drainage Area Map.** A drainage area map supporting the following requirements is attached:
- For areas that will have more than 10 acres within a common drainage area disturbed at one time, a sediment basin will be provided.
 - For areas that will have more than 10 acres within a common drainage area disturbed at one time, a smaller sediment basin and/or sediment trap(s) will be used.
 - For areas that will have more than 10 acres within a common drainage area disturbed at one time, a sediment basin or other equivalent controls are not attainable, but other TBMPs and measures will be used in combination to protect down slope and side slope boundaries of the construction area.
 - There are no areas greater than 10 acres within a common drainage area that will be disturbed at one time. A smaller sediment basin and/or sediment trap(s) will be used in combination with other erosion and sediment controls within each disturbed drainage area.

- There are no areas greater than 10 acres within a common drainage area that will be disturbed at one time. Erosion and sediment controls other than sediment basins or sediment traps within each disturbed drainage area will be used.
11. **Attachment H - Temporary Sediment Pond(s) Plans and Calculations.** Temporary sediment pond or basin construction plans and design calculations for a proposed temporary BMP or measure have been prepared by or under the direct supervision of a Texas Licensed Professional Engineer. All construction plans and design information must be signed, sealed, and dated by the Texas Licensed Professional Engineer. Construction plans for the proposed temporary BMPs and measures are attached.
- N/A
12. **Attachment I - Inspection and Maintenance for BMPs.** A plan for the inspection of each temporary BMP(s) and measure(s) and for their timely maintenance, repairs, and, if necessary, retrofit is attached. A description of the documentation procedures, recordkeeping practices, and inspection frequency are included in the plan and are specific to the site and/or BMP.
13. All control measures must be properly selected, installed, and maintained in accordance with the manufacturer's specifications and good engineering practices. If periodic inspections by the applicant or the executive director, or other information indicate a control has been used inappropriately, or incorrectly, the applicant must replace or modify the control for site situations.
14. If sediment escapes the construction site, off-site accumulations of sediment must be removed at a frequency sufficient to minimize offsite impacts to water quality (e.g., fugitive sediment in street being washed into surface streams or sensitive features by the next rain).
15. Sediment must be removed from sediment traps or sedimentation ponds not later than when design capacity has been reduced by 50%. A permanent stake will be provided that can indicate when the sediment occupies 50% of the basin volume.
16. Litter, construction debris, and construction chemicals exposed to stormwater shall be prevented from becoming a pollutant source for stormwater discharges (e.g., screening outfalls, picked up daily).

Soil Stabilization Practices

Examples: establishment of temporary vegetation, establishment of permanent vegetation, mulching, geotextiles, sod stabilization, vegetative buffer strips, protection of trees, or preservation of mature vegetation.

17. **Attachment J - Schedule of Interim and Permanent Soil Stabilization Practices.** A schedule of the interim and permanent soil stabilization practices for the site is attached.

18. Records must be kept at the site of the dates when major grading activities occur, the dates when construction activities temporarily or permanently cease on a portion of the site, and the dates when stabilization measures are initiated.
19. Stabilization practices must be initiated as soon as practicable where construction activities have temporarily or permanently ceased.

Administrative Information

20. All structural controls will be inspected and maintained according to the submitted and approved operation and maintenance plan for the project.
21. If any geologic or manmade features, such as caves, faults, sinkholes, etc., are discovered, all regulated activities near the feature will be immediately suspended. The appropriate TCEQ Regional Office shall be immediately notified. Regulated activities must cease and not continue until the TCEQ has reviewed and approved the methods proposed to protect the aquifer from any adverse impacts.
22. Silt fences, diversion berms, and other temporary erosion and sediment controls will be constructed and maintained as appropriate to prevent pollutants from entering sensitive features discovered during construction.



EVER ENGINEERING
Advanced Engineering Services

**Section 5: TEMPORARY STORM WATER SECTION (TCEQ-0602)
ATTACHMENT A**

**Savage Land Solutions, LLC.
SPILL RESPONSE ACTIONS**

In the event of accidental spills of hazardous materials or hydrocarbons, the contractor will be required to maintain a stockpile of sand material in the construction staging area. This sand material will be used to provide a dike to contain large spills and to provide an absorbent material that can be disposed of off the Edwards Aquifer Recharge, Contributing and Transition Zones during the cleanup process. The contractor will be required to contact the owner, who will notify TCEQ in the event of a spill. It is required that all contaminated soils be removed from the project site and disposed of in accordance with applicable regulations off of the Edwards Aquifer Recharge, Contributing, Transition Zones. Below are measures by TCEQ for spill prevention and response.

EDUCATION:

1. Be aware that different materials pollute in different amounts. Make sure that each employee knows what a “significant spill” is for each material they use, and what is the appropriate response for “significant” and “insignificant” spills. Employees should also be aware of when spills must be reported to the TCEQ. Information is available in 30 TAC 327.4 and 40 CFR 302.4.
2. Educate employees and subcontractors on potential dangers to humans and the environment from spills and leaks
3. Hold Regular meetings to discuss and reinforce appropriate disposal procedures (incorporate into regular safety meetings).
4. Establish a continuing education program to indoctrinate new employees.
5. Have contractor’s superintendent or representative oversee and enforce proper spill prevention and control measures.

GENERAL MEASURES:

1. To the extent that the work can be accomplished safely, spills of oil, petroleum products, substances listed under 40 CFR parts 110,117, and 302, and sanitary and septic wastes should be contained and cleaned up immediately.

2. Store hazardous materials and waste in covered containers and protect from vandalism.
3. Place a stockpile of spill cleanup materials where it will be readily accessible.

4. Train employees in spill prevention and cleanup
5. Designate responsible individuals to oversee and enforce control measures.
6. Spills should be covered and protected from stormwater runoff during rainfall to the extent that it doesn't compromise clean-up activities.
7. Do not bury or wash spills in water
8. Store and dispose of used clean up materials, contaminated materials, and recovered spill materials that is no longer suitable for the intended purpose in conformance with the provisions in applicable BMPs.
9. Do not allow water used for cleaning and decontamination to enter storm drains or watercourses. Collect and dispose of contaminated water in accordance with applicable regulations.
10. Contain water overflow or minor water spillage and do not allow it to discharge into drainage facilities or watercourses.
11. Place Material Safety Data (MSDS), as well as proper storage, cleanup, and spill reporting instructions for hazardous materials stored or used on the project site in an open, conspicuous, and accessible location.
12. Keep waste storage areas clean, well-organized, and equipped with ample cleanup supplies as appropriate for the materials being stored. Perimeter controls, containment structures, cover, and liners should be repaired or replaced as needed to maintain proper function.

CLEANUP:

1. Clean up leaks and spills immediately.
2. Use a rag for small spills on paved surfaces, a damp mop for general cleanup, and absorbent material for larger spills. If the spilled material is hazardous, then the used cleanup materials are also hazardous and must be disposed of as a hazardous waste
3. Never hose down or bury dry material spills. Clean up as much of the material as possible and dispose of properly. See the waste management BMPs in this section for specific information.

MINOR SPILLS:

1. Minor spills typically involve small quantities of oil, gasoline, paint, etc. which can be controlled by the first responder at the discovery of the spill
2. Use absorbent materials on small spills rather than hosing down or burying the spill.
3. Absorbent materials should be promptly removed and disposed of properly.
4. Follow the practice below for a minor spill
 - a. Contain the spread of the spill.
 - b. Recover spilled materials
 - c. Clean the contaminated area and properly dispose of contaminated materials.

SEMI-SIGNIFICANT SPILLS

Semi-significant spills can be controlled by the first responder along with the aid of other personnel such as laborers and the foreman, etc. this response may require the cessation of all other activities. Spills should be cleaned up immediately:

1. Contain spread of the spill
2. Notify the project foreman immediately.
3. If the spill occurs on paves or impermeable surfaces, clean up using “dry methods” (absorbent materials, cat litter and/or rags). Contain the spill by encircling with absorbent materials and do not let the spill spread widely.
4. If the spill occurs in dirt areas, immediately contain the spill by constructing an earthen dike. Dig up and properly dispose of contaminated soil.
5. If the spill occurs during rain, cover spill with tarps or other material to prevent contaminating runoff.

SIGNIFICANT/HAZARDOUS SPILLS

For significant or hazardous spills that are in reportable quantities:

1. Notify the TCEQ by telephone as soon as possible and within 24 hours at 512-339-2929 (Austin) or 210-490-3096 (San Antonio) between 8AM and 5PM. After hours, contact the Environmental Release Hotline at 1-800-832-8224. It is the contractor’s responsibility to have all emergency phone numbers at the construction site.
2. For spills of federal reportable quantities, in conformance with the requirements in 50 CFR parts 110.119, and 302, the contractor should notify the National Response Center at (800) 424-8802.
3. Notification should first be made by telephone and followed up with a written report.
4. The services of a spill contractor or a Haz-Mat team should be obtained immediately. Construction personnel should not attempt to clean up until the appropriate and qualified staff have arrived at the job site.
5. Other agencies which may need to be consulted include, but are not limited to, the City Police Department, County Sheriff Office, Fire Departments, etc.
6. Use absorbent materials on small spills rather than hosing down or burying the spill. Remove the absorbent materials promptly and dispose of properly.
7. Promptly transfer used fluid to the proper waste or recycling drums. Don’t leave full drip pans or other open containers lying around.
8. Oil filters disposed of in trashcans or dumpsters can leak oil and pollute stormwater. Place the oil filter in a funnel over a waste oil-recycling drum to drain excess oil before disposal. Oil filters can also be recycled. Ask the oil supplier or recycler about recycling oil filters.
9. Store cracked batteries in a non-leaking secondary container. Do this with all cracked batteries even if you think all the acid has drained out. If you drop a battery, treat it as if it is cracked. Put it into the containment area until you are sure it is not leaking.

VEHICLE AND EQUIPMENT FUELING

1. If fueling must occur on site, use designated areas, located away from drainage courses, to prevent the runoff of stormwater and the runoff of spills.
2. Discourage "topping off" of fuel tanks.
3. Always use secondary containment, such as a drain pan, when fueling to catch spills/leaks



EVER ENGINEERING

Advanced Engineering Services

**Section 5: TEMPORARY STORM WATER SECTION (TCEQ-0602)
ATTACHMENT B**

**Savage Land Solutions, LLC.
POTENTIAL SOURCES OF CONTAMINATION**

POTENTIAL SOURCES OF POLLUTANTS DURING CONSTRUCTION:

1. Soil, erosion due to construction.
2. Oil, grease, fuel and hydraulic fluid contamination from construction equipment and vehicle drippings
3. Volatile organic compounds are released from on-site pavement striping paint and thermoplastic.
4. Miscellaneous trash and debris from construction and material wrappings.
5. Proposed sewer connection.
6. Portable toilet spills.

POTENTIAL SOURCES OF POLLUTANTS AFTER CONSTRUCTION:

1. Traffic related pollutants from cars, roads, and driveways.
2. Improper disposal of trash.
3. Pesticides, herbicides and fertilizers.

Please refer to Attachment A: Spill Response Actions-Form 0602 for details for preventative and responsive actions of this report.



EVER ENGINEERING

Advanced Engineering Services

**Section 5: TEMPORARY STORM WATER SECTION (TCEQ-0602)
ATTACHMENT C**

**Savage Land Solutions, LLC.
SEQUENCE OF MAJOR ACTIVITIES**

1. Installation of temporary BMPs
2. Site clearing activities (approximately 1.8558-Acres)
3. Subgrade Preparation (earthwork, grading) (Approximately 1.8558-Acres)
4. Wet and Dry Utility Construction (Approximately 176 linear feet)
5. Installation of base materials (Approximately 0.0317-Acres)
6. Concrete (foundations, curbs, flatwork) (Approximately 0.1510-Acres)
7. Building Construction
8. Site cleanup and removal of temporary BMPs



EVER ENGINEERING
Advanced Engineering Services

**Section 5: TEMPORARY STORM WATER SECTION (TCEQ-0602)
ATTACHMENT D**

**Savage Land Solutions, LLC.
TEMPORARY BEST MANAGEMENT PRACTICE AND MEASURES**

Silt fencing, construction staging area, concrete truck wash-out pit, and a temporary construction entrance/exit will be used in accordance with the latest edition TCEQ Technical Guidance Manual details and criteria, to prevent pollution of surface water and groundwater that originates both up-gradient and on-site.

Silt fence, construction entrance/exit, and a concrete truck wash-out pit shall be in place before the first phase of construction for the commercial site is to begin. The temporary construction entrance/exit, construction staging area and concrete washout pit will prevent sediments from flowing into public right-of-way. The fencing will be installed downstream of cut/fill areas. The locations of the silt fence were based on the criteria to limit the drainage area of disturbed soil to ¼ acres per 100 linear feet of fencing.

There is a known well identified within the subject tract Geologic Site Assessment. The Temporary and Permanent Pollution Abatement measure for construction is included in this section.



EVER ENGINEERING

Advanced Engineering Services

**Section 5: TEMPORARY STORM WATER SECTION (TCEQ-0602)
ATTACHMENT E**

**Savage Land Solutions, LLC.
REQUEST TO TEMPORARILY SEAL A FEATURE**

This attachment does not apply to this submittal. There will be no temporary sealing of sensitive features on the site.



EVER ENGINEERING

Advanced Engineering Services

**Section 5: TEMPORARY STORM WATER SECTION (TCEQ-0602)
ATTACHMENT F**

**Savage Land Solutions, LLC.
STRUCTURAL PRACTICES**

Structural BMPs will be used to limit runoff discharge of pollutants from exposed areas of the site. BMPs will be installed prior to soil disturbing construction activity. Silt fencing will be placed along the down gradient sides of the property to prevent silt from escaping the construction area. Inlet protection will be placed on all storm water inlets to prevent pollutants from entering the stormwater drainage system. A temporary construction entrance will be placed at the site entry/exit point to reduce tracking onto adjoining streets. A construction staging area will be used onsite to perform all vehicle maintenance and for equipment and material storage. A concrete truck wash-out pit will be placed on the site to provide containment and easier cleanup of waste from concrete operations. The location of all structural temporary BMPs is shown on the site plan within the attachments.



EVER ENGINEERING

Advanced Engineering Services

**Section 5: TEMPORARY STORM WATER SECTION (TCEQ-0602)
ATTACHMENT G**

**Savage Land Solutions, LLC.
PROPOSED DRAINAGE AREA PLAN**

The overall drainage area for the area included within the WPAP modification is 3.19-acres and is shown on the attached Proposed Drainage Area Plan.



DATE: SEPTEMBER 2022
 JOB NO.: 22-0106
 CHECKED: RDM
 DRAWN: GV
 TBO:
 PLAN NO.:

DEVELOPED/ULTIMATE
 CONDITIONS MAP

REVISIONS

DATE	DESCRIPTION

PROJECT LOCATION:
 300 FM 32
 SAN MARCOS, TEXAS 78666

EVER ENGINEERING, LLC
 ADVANCED ENGINEERING SERVICES
 3201 CHERRY RIDGE DRIVE, SUITE A-106,
 SAN ANTONIO, TX 78230
 OFFICE (210) 572-9340 FAX (210) 572-9344
 WWW.EVERENC.COM, WWW.AES-TX.COM
 FIRM NO. E-19197



200 FM 32

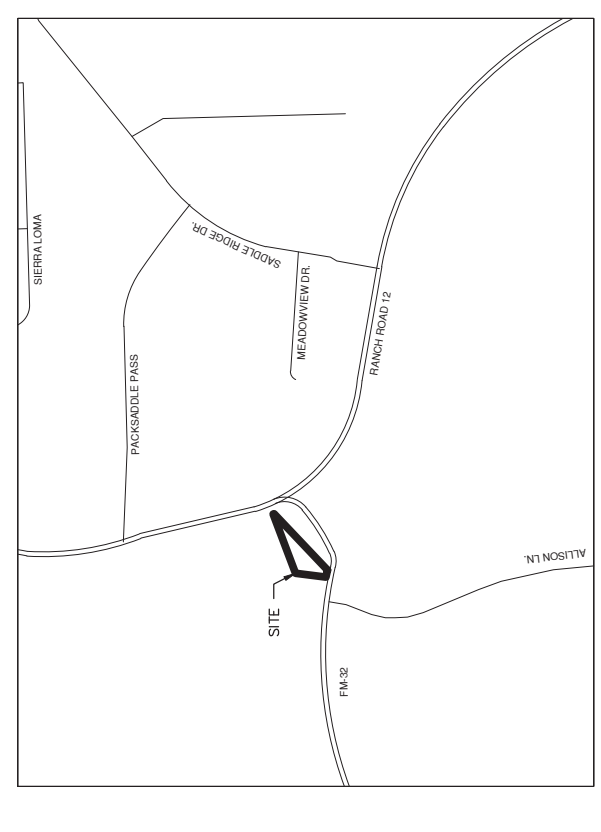

LOCATION MAP
 NOT TO SCALE

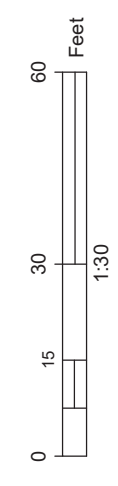
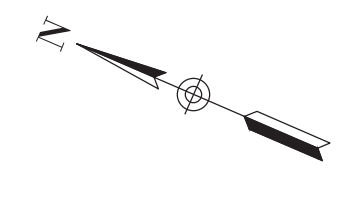

LEGEND

- PROPERTY LINE
- EXISTING CONTOUR
- PROPOSED CONTOUR
- ON-SITE WATERSHED
- TC PATH
- FLOW ARROW (EXISTING)

Watershed	Area (ac)	C (unless)	Tc (min)	Flow (cfs)
ULTIMATE/DEVELOPED	2	10	25	100
ON-SITE WS-1	3.19	0.60	11	9.32
ON-SITE WS-2	0.22	0.69	5	1.37
ON-SITE WS-3	2.87	0.60	11	7.95
RETENTION				11.26
				13.40
				16.65

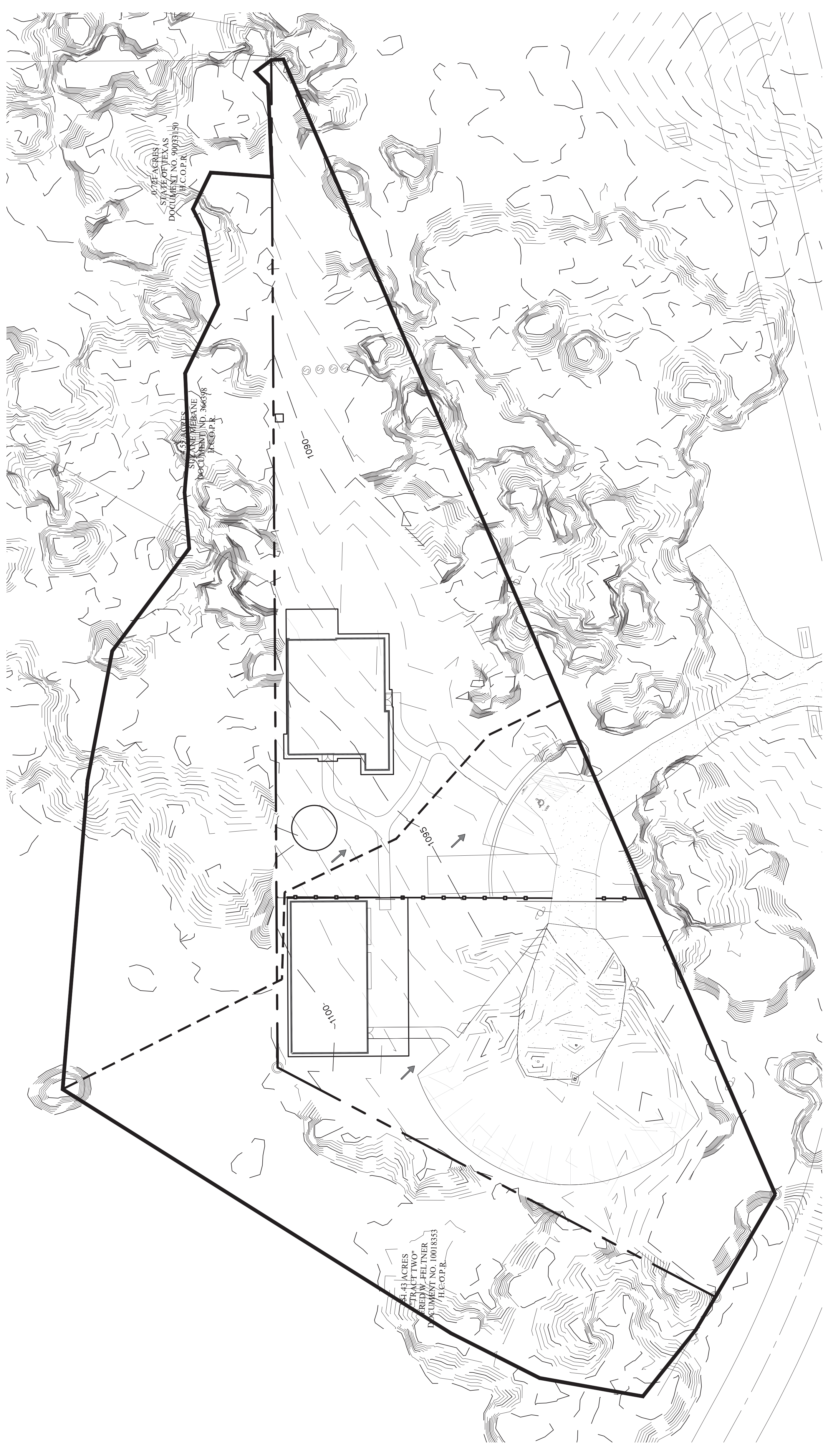

LEGAL DESCRIPTION
 1.8558-ACRE TRACT
 ABS 25
 JAMES ALSTON SURVEY



EVER ENGINEERING

Advanced Engineering Services

**Section 5: TEMPORARY STORM WATER SECTION (TCEQ-0602)
ATTACHMENT H**

**Savage Land Solutions, LLC.
TEMPORARY SEDIMENT PONDS(S) PLANS AND CALCULATIONS**

This attachment does not apply to this submittal. There are no drainage areas with disturbed areas greater than 10 acres.



EVER ENGINEERING

Advanced Engineering Services

Section 5: TEMPORARY STORM WATER SECTION (TCEQ-0602) ATTACHMENT I

Savage Land Solutions, LLC. INSPECTION AND MAINTENANCE FOR BMPS

- **Check dam inspection and Maintenance Guidelines:**
 - Contractor shall make inspections weekly, and after any rainfall.
 - Once sediment and debris build up reaches 6 inches it shall be removed and disposed of in a site acceptable manner.
 - Any loose or damaged wire shall be repaired
 - Berm shall be reshaped as needed
 - The dam shall be replaced when the structure no longer functions as it was designed, due to silt accumulation, construction traffic, etc.
 - The check dam shall be left in place until all upstream disturbed areas are stabilized and the accumulated silt has been removed.
- **Silt Fence inspection and Maintenance Guidelines:**
 - Contractor shall make inspections weekly, and after any rainfall.
 - Once sediment and debris build up reaches 6 inches it shall be removed and disposed of in a site acceptable manner.
 - Any torn fabric shall be replaced, and new fencing shall be installed parallel to new section.
 - If a silt fence is located in an area of high construction traffic, then it is to be relocated to an area that will provide equal protection, but will not impede vehicular movements.
- **Construction Entrance/ Exit Maintenance Guidelines:**
 - The entrance shall be maintained in a way that will prevent tracking of sediment onto the public right-of-way
 - Any sediment that reaches the right-of-way must be removed immediately by the contractor.
 - When necessary, wheels should be washed to remove excess sediment.
 - When washing is necessary, it is to be performed in an area that is stable and protected, so that no sediment enters any public right-of-way, stream, or sensitive area.

- **Concrete Washout Area Inspection and Maintenance Guidelines:**
 - Contractor shall make inspections weekly, and after any rainfall.
 - When concrete accumulates 6 inches in depth, it is to be broken up, removed, and disposed.
 - All controls around the perimeter of the washout area shall be checked, maintained, and repaired as necessary.
 - Upon completion of construction, the concrete washout area shall be cleaned, and all concrete shall be removed and disposed of properly. Holes, depressions or other ground disturbances caused by removal of washout shall be backfilled and repaired.
- **Soil Treatment Guidelines:**
 - Contractor shall apply temporary stabilization methods where it is shown on the C2.10 sheet.
 - Temporary stabilization methods shall be replaced when torn or no longer effective.
 - Temporary stabilization is to be replaced with permanent vegetation and disturbed area vegetation at appropriate times, as called out by C2.10 series.



EVER ENGINEERING

Advanced Engineering Services

**Section 5: TEMPORARY STORM WATER SECTION (TCEQ-0602)
ATTACHMENT J**

Savage Land Solutions, LLC.

SCHEDULE OF INTERIM AND PERMANENT SOIL STABILIZATION PRACTICES

- **Temporary Stabilization**

No bare ground exposed during construction will be left to stabilize naturally. Any disturbed areas where construction activities have ceased, permanently or temporarily, shall be treated with temporary stabilization of the area within 14 days, unless construction is set to begin in this area within 21 days. Temporary seeding shall follow TXDOT item 164 – Seeding for Erosion Control

- **Permanent Stabilization**

All disturbed areas where construction has permanently ceased shall be seeded no more than 14 days after the last activity. Permanent seeding shall follow TXDOT item 164 – seeding for Erosion Control. It shall be the contractor's responsibility to sufficiently water the areas so that a minimum of 70% stabilization is achieved.



EVER ENGINEERING

Advanced Engineering Services

Section 6

Savage Land Solutions, LLC.

PERMANENT STORM WATER SECTION (TCEQ-0600)

Permanent Stormwater Section

Texas Commission on Environmental Quality

for Regulated Activities on the Edwards Aquifer Recharge Zone and Relating to 30 TAC §213.5(b)(4)(C), (D)(li), (E), and (5), Effective June 1, 1999

To ensure that the application is administratively complete, confirm that all fields in the form are complete, verify that all requested information is provided, consistently reference the same site and contact person in all forms in the application, and ensure forms are signed by the appropriate party.

Note: Including all the information requested in the form and attachments contributes to more streamlined technical reviews.

Signature

To the best of my knowledge, the responses to this form accurately reflect all information requested concerning the proposed regulated activities and methods to protect the Edwards Aquifer. This **Permanent Stormwater Section** is hereby submitted for TCEQ review and executive director approval. The application was prepared by:

Print Name of Customer/Agent: Gerardo Villarreal

Date: 1/13/23

Signature of Customer/Agent



Regulated Entity Name: Savage Land Solutions

Permanent Best Management Practices (BMPs)

Permanent best management practices and measures that will be used during and after construction is completed.

- Permanent BMPs and measures must be implemented to control the discharge of pollution from regulated activities after the completion of construction.
 N/A
- These practices and measures have been designed, and will be constructed, operated, and maintained to insure that 80% of the incremental increase in the annual mass loading of total suspended solids (TSS) from the site caused by the regulated activity is removed. These quantities have been calculated in accordance with technical guidance prepared or accepted by the executive director.
 The TCEQ Technical Guidance Manual (TGM) was used to design permanent BMPs and measures for this site.

A technical guidance other than the TCEQ TGM was used to design permanent BMPs and measures for this site. The complete citation for the technical guidance that was used is: _____

N/A

3. Owners must insure that permanent BMPs and measures are constructed and function as designed. A Texas Licensed Professional Engineer must certify in writing that the permanent BMPs or measures were constructed as designed. The certification letter must be submitted to the appropriate regional office within 30 days of site completion.

N/A

4. Where a site is used for low density single-family residential development and has 20 % or less impervious cover, other permanent BMPs are not required. This exemption from permanent BMPs must be recorded in the county deed records, with a notice that if the percent impervious cover increases above 20% or land use changes, the exemption for the whole site as described in the property boundaries required by 30 TAC §213.4(g) (relating to Application Processing and Approval), may no longer apply and the property owner must notify the appropriate regional office of these changes.

The site will be used for low density single-family residential development and has 20% or less impervious cover.

The site will be used for low density single-family residential development but has more than 20% impervious cover.

The site will not be used for low density single-family residential development.

5. The executive director may waive the requirement for other permanent BMPs for multi-family residential developments, schools, or small business sites where 20% or less impervious cover is used at the site. This exemption from permanent BMPs must be recorded in the county deed records, with a notice that if the percent impervious cover increases above 20% or land use changes, the exemption for the whole site as described in the property boundaries required by 30 TAC §213.4(g) (relating to Application Processing and Approval), may no longer apply and the property owner must notify the appropriate regional office of these changes.

Attachment A - 20% or Less Impervious Cover Waiver. The site will be used for multi-family residential developments, schools, or small business sites and has 20% or less impervious cover. A request to waive the requirements for other permanent BMPs and measures is attached.

The site will be used for multi-family residential developments, schools, or small business sites but has more than 20% impervious cover.

The site will not be used for multi-family residential developments, schools, or small business sites.

6. **Attachment B - BMPs for Upgradient Stormwater.**

- A description of the BMPs and measures that will be used to prevent pollution of surface water, groundwater, or stormwater that originates upgradient from the site and flows across the site is attached.
 - No surface water, groundwater or stormwater originates upgradient from the site and flows across the site, and an explanation is attached.
 - Permanent BMPs or measures are not required to prevent pollution of surface water, groundwater, or stormwater that originates upgradient from the site and flows across the site, and an explanation is attached.
7. **Attachment C - BMPs for On-site Stormwater.**
- A description of the BMPs and measures that will be used to prevent pollution of surface water or groundwater that originates on-site or flows off the site, including pollution caused by contaminated stormwater runoff from the site is attached.
 - Permanent BMPs or measures are not required to prevent pollution of surface water or groundwater that originates on-site or flows off the site, including pollution caused by contaminated stormwater runoff, and an explanation is attached.
8. **Attachment D - BMPs for Surface Streams.** A description of the BMPs and measures that prevent pollutants from entering surface streams, sensitive features, or the aquifer is attached. Each feature identified in the Geologic Assessment as sensitive has been addressed.
- N/A
9. The applicant understands that to the extent practicable, BMPs and measures must maintain flow to naturally occurring sensitive features identified in either the geologic assessment, executive director review, or during excavation, blasting, or construction.
- The permanent sealing of or diversion of flow from a naturally-occurring sensitive feature that accepts recharge to the Edwards Aquifer as a permanent pollution abatement measure has not been proposed.
 - Attachment E - Request to Seal Features.** A request to seal a naturally-occurring sensitive feature, that includes, for each feature, a justification as to why no reasonable and practicable alternative exists, is attached.
10. **Attachment F - Construction Plans.** All construction plans and design calculations for the proposed permanent BMP(s) and measures have been prepared by or under the direct supervision of a Texas Licensed Professional Engineer, and are signed, sealed, and dated. The plans are attached and, if applicable include:
- Design calculations (TSS removal calculations)
 - TCEQ construction notes
 - All geologic features
 - All proposed structural BMP(s) plans and specifications
- N/A

11. **Attachment G - Inspection, Maintenance, Repair and Retrofit Plan.** A plan for the inspection, maintenance, repairs, and, if necessary, retrofit of the permanent BMPs and measures is attached. The plan includes all of the following:
- Prepared and certified by the engineer designing the permanent BMPs and measures
 - Signed by the owner or responsible party
 - Procedures for documenting inspections, maintenance, repairs, and, if necessary retrofit
 - A discussion of record keeping procedures
- N/A
12. **Attachment H - Pilot-Scale Field Testing Plan.** Pilot studies for BMPs that are not recognized by the Executive Director require prior approval from the TCEQ. A plan for pilot-scale field testing is attached.
- N/A
13. **Attachment I -Measures for Minimizing Surface Stream Contamination.** A description of the measures that will be used to avoid or minimize surface stream contamination and changes in the way in which water enters a stream as a result of the construction and development is attached. The measures address increased stream flashing, the creation of stronger flows and in-stream velocities, and other in-stream effects caused by the regulated activity, which increase erosion that results in water quality degradation.
- N/A

Responsibility for Maintenance of Permanent BMP(s)

Responsibility for maintenance of best management practices and measures after construction is complete.

14. The applicant is responsible for maintaining the permanent BMPs after construction until such time as the maintenance obligation is either assumed in writing by another entity having ownership or control of the property (such as without limitation, an owner's association, a new property owner or lessee, a district, or municipality) or the ownership of the property is transferred to the entity. Such entity shall then be responsible for maintenance until another entity assumes such obligations in writing or ownership is transferred.
- N/A
15. A copy of the transfer of responsibility must be filed with the executive director at the appropriate regional office within 30 days of the transfer if the site is for use as a multiple single-family residential development, a multi-family residential development, or a non-residential development such as commercial, industrial, institutional, schools, and other sites where regulated activities occur.
- N/A



EVER ENGINEERING

Advanced Engineering Services

**Section 6: PERMANENT STORM WATER SECTION (TCEQ-0600)
ATTACHMENT A**

**Savage Land Solutions, LLC.
20% OR LESS IMPERVIOUS COVER WAIVER (TCEQ-0600)**

The proposed development does not generate less than 20% of impervious cover therefore, this attachment does not apply to this submittal.



EVER ENGINEERING

Advanced Engineering Services

**Section 6: PERMANENT STORM WATER SECTION (TCEQ-0600)
ATTACHMENT B**

**Savage Land Solutions, LLC.
BMPS FOR UPGRADIENT STORMWATER (TCEQ-0600)**

Engineered vegetative filter strips will be applied to reduce contaminants heading downstream. These practices will assure that a minimal number of harmful pollutants will infiltrate into the ground water.



EVER ENGINEERING

Advanced Engineering Services

**Section 6: PERMANENT STORM WATER SECTION (TCEQ-0600)
ATTACHMENT C**

**Savage Land Solutions, LLC.
BMPS FOR ON-SITE STORMWATER (TCEQ-0600)**

The stormwater runoff generated from the project site will be treated using vegetated filter strip (VFS) and an above ground water tank. The VFS is designed according to the TCEQ technical guidance on Best Management Practices Manual. The Sizing calculations for the VFS and the tank can be found on WQ-1.



EVER ENGINEERING

Advanced Engineering Services

**Section 6: PERMANENT STORM WATER SECTION (TCEQ-0600)
ATTACHMENT D**

**Savage Land Solutions, LLC.
BMPS FOR SURFACE STREAMS (TCEQ-0600)**

This attachment does not apply to this submittal. There are no surface streams existing on site.



EVER ENGINEERING

Advanced Engineering Services

**Section 6: PERMANENT STORM WATER SECTION (TCEQ-0600)
ATTACHMENT E**

**Savage Land Solutions, LLC.
REQUEST TO SEAL FEATURES (TCEQ-0600)**

This attachment does not apply to this submittal. There are no sensitive geologic features on the site.



EVER ENGINEERING

Advanced Engineering Services

**Section 6: PERMANENT STORM WATER SECTION (TCEQ-0600)
ATTACHMENT F**

Savage Land Solutions, LLC.

WATER QUALITY TREATMENT CALCULATIONS & CONSTRUCTION PLANS

Water Quality Treatment Calculations and construction plans of structural BMPs for the site are following this sheet.

LEGAL DESCRIPTION

1.8558-ACRE TRACT
ABS 25
JAMES ALSTON SURVEY

SAVAGE LAND SOLUTIONS HO

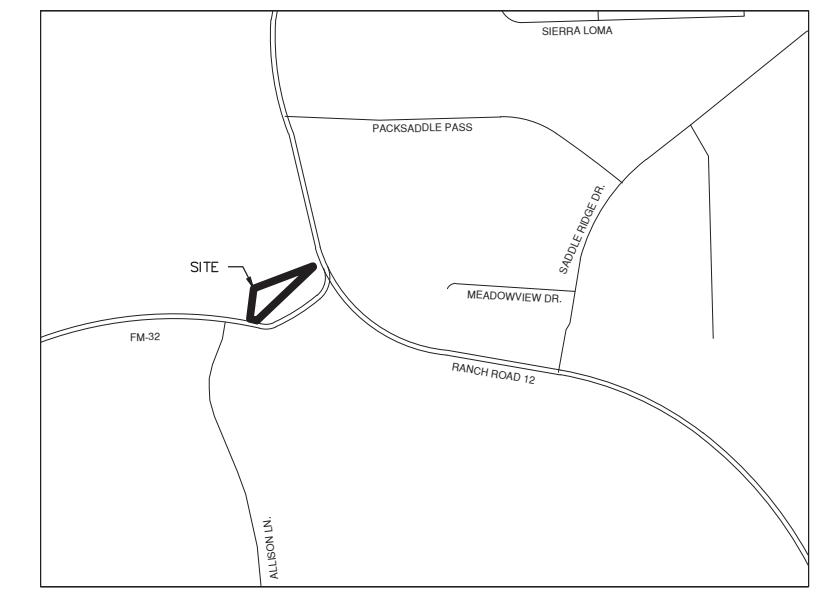

LOCATION MAP
NOT-TO-SCALE

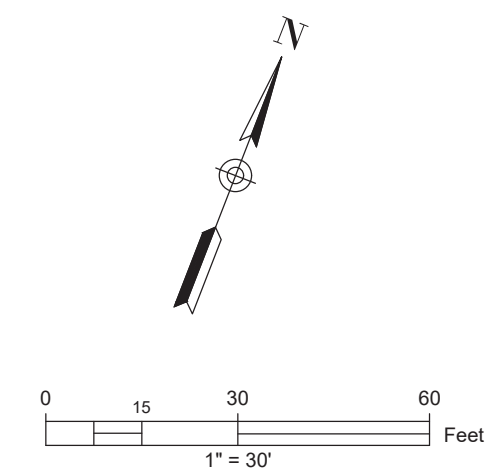

LEGEND

PROPERTY LINE	---
EXISTING CONTOUR	- - - - - 850
PROPOSED CONTOUR	_____ 850

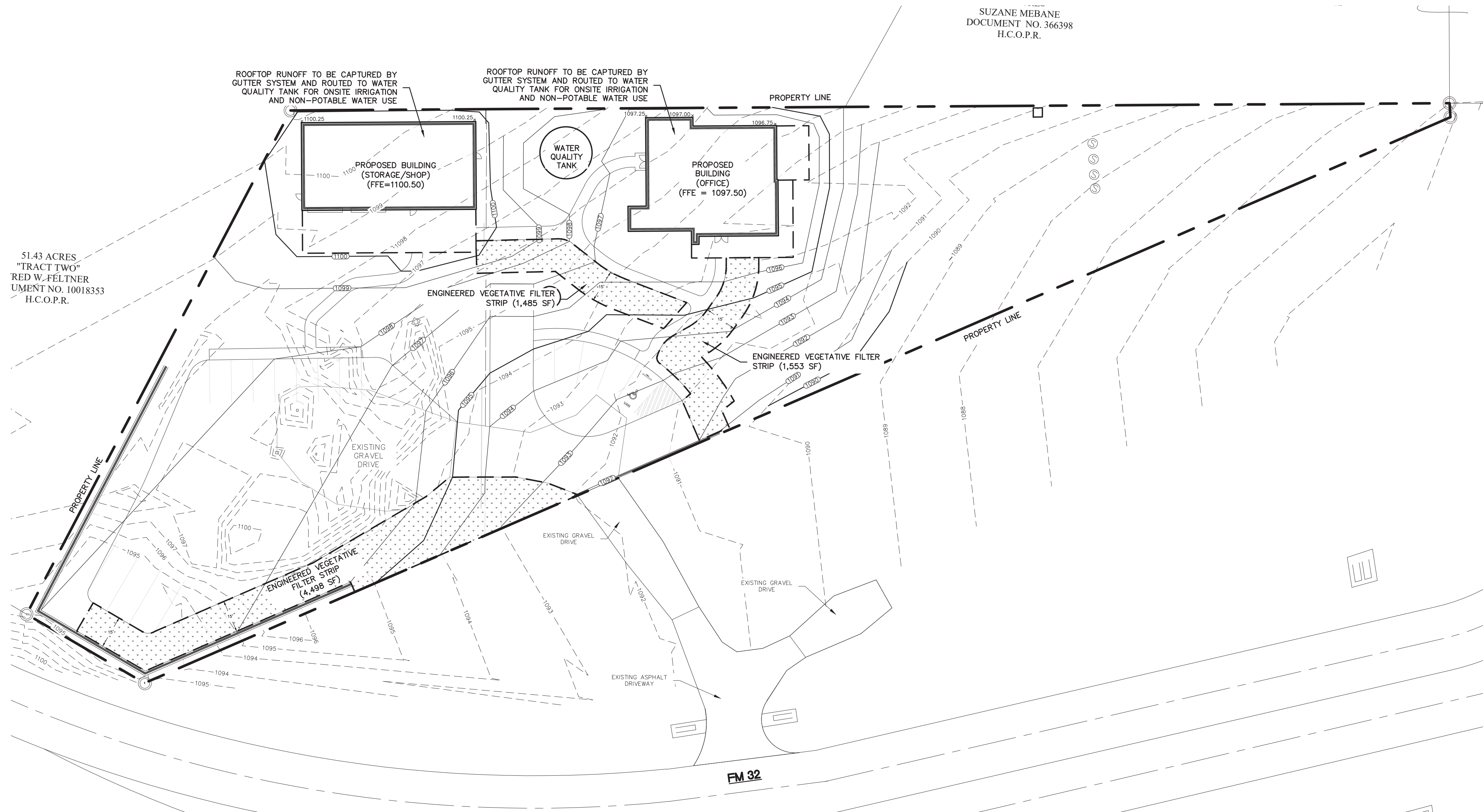

51.43 ACRES
"TRACT TWO"
RED W. FELTNER
UMENT NO. 10018353
H.C.O.P.R.

SUZANE MEBANE
DOCUMENT NO. 366398
H.C.O.P.R.

FM 32

BMP NOTES:

- NATURAL VEGETATIVE FILTER STRIP:
- ALL NO PORTION OF THE NATURAL FILTER AREA SHALL EXCEED A SLOPE OF 10%.
 - FLOW LENGTH OVER THE VEGETATIVE FILTER OR FILTER WIDTH MUST BE AT LEAST 50 FEET AND NO GREATER THAN 72 FEET.
 - THE FILTER STRIP MUST RUN ALONG THE ENTIRE EDGE OF THE CONTRIBUTING AREA. THE SOIL ALONG THE UPPER BOUNDARY MUST BE REINFORCED WITH PROTECTIVE MATTING OR AN INFILTRATION TRENCHED (PREFERRED) MAY BE USED. REFER TO FIGURE 4.14, THIS SHEET.
 - THE FILTER AREA MUST BE FREE OF GULLIES, RILLS, AND FLOW CONCENTRATION AND HAVE 80% VEGETATIVE COVER.
 - THE SOIL MUST AVERAGE 4-INCHES IN DEPTH. ROCK CROP AREAS MAY BE PRESENT BUT MUST NOT BE DEDUCTED FROM THE FILTER STRIP AREA AND MUST NOT AFFECT THE FUNCTION OF THE VEGETATIVE FILTER STRIP.
- ENGINEERED VEGETATIVE FILTER STRIP:
- NO PORTION OF THE FILTER AREA SHALL EXCEED A SLOPE OF 20%.
 - THE FLOW LENGTH OF OVER THE VEGETATIVE FILTER OR FILTER WIDTH MUST BE AT LEAST 15 FEET AND NO GREATER THAN 72 FEET.
 - THE FILTER STRIP MUST RUN ALONG THE ENTIRE EDGE OF THE CONTRIBUTING AREA. THE SOIL ALONG THE UPPER BOUNDARY MUST BE REINFORCED WITH PROTECTIVE MATTING OR AN INFILTRATION TRENCHED (PREFERRED) MAY BE USED. REFER TO FIGURE 4.15, THIS SHEET.
 - THE FILTER AREA, AFTER FINAL GRADING, SHOULD HAVE A UNIFORM AND EVEN SLOPE AND BE CAPABLE OF MAINTAINING AN EVEN SHEET FLOW ACROSS THE ENTIRE FILTER SURFACE. THE FILTER AREA MUST BE FREE OF GULLIES, RILLS, AND FLOW CONCENTRATIONS. THE STRIP MUST BE SODDED OR IF SEED IS USED IT MUST BE ACCOMPANIED BY THE APPROPRIATE SOIL BLANKET OR MATTING PER TCEQ SPEC 3.2.11.
 - A MINIMUM OF 6-INCHES OF TOPSOIL IS REQUIRED. THE TOPSOIL MUST CONTAIN 10-20% COMPOST, A CLAY CONTENT LESS THAN 20% AND BE FREE OF STONES, ROOTS OR OTHER SIMILAR OBJECTS LARGER THAN ONE (1) INCH. IF ON-SITE SOILS DO NOT MEET SPECIFICATIONS, TOPSOIL PER THE ABOVE SPECS MUST BE ADDED. SANDY LOAM IS NOT AN APPROVED SOIL AND CALICHE IS NOT CONSIDERED SOIL.
 - AN INFILTRATION BERM IS REQUIRED AT THE DOWNGRADEMENT END OF THE FILTER STRIP WITH A SLOPE GREATER THAN 2% BERM SIDE SLOPES SHOULD BE A SLOPE GREATER THAN 3:1, AND BERM TOP-WIDTH SHOULD BE 4-8 INCHES.

Texas Commission on Environmental Quality

TSS Removal Calculations 04-20-2009

Project Name: Savage Land Solutions
Date Prepared: 11/22/2022

Additional information is provided for cells with a red triangle in the upper right corner. Place the cursor over the cell. Text shown in blue indicate location of instructions in the Technical Guidance Manual - RG-348.

Character shown in black (BOLD) are calculated fields. Changes to these fields will remove the equations used in the spreadsheet.

1. The Required Load Reduction for the total project:

Calculations from RG-348 Pages 3-27 to 3-30

Page 3-29 Equation 3.2: $L_{TSS, project} = R_{TSS} \times (A_{imp} + 2 \times A_{p})$

where:

- $L_{TSS, project}$ = Required TSS removal resulting from the proposed development = 80% of increased
- A_{imp} = Net increase in impervious area for the project
- P = Average annual precipitation, inches

Site Data: Determine Required Load Reduction Based on the Entire Project

County	Hays
Total project area (including plan)	1.36 acres
Predevelopment impervious area within the limits of the plan	0.14 acres
Total post-development impervious area within the limits of the plan	0.29 acres
Total post-development impervious cover fraction	0.21
P	33 inches

* The values entered in these fields should be for the total project area.

$L_{TSS, project} = 300$ lbs.

Number of drainage basins / outfalls areas leaving the plan area = 1

2. Drainage Basin Parameters (This information should be provided for each basin):

Drainage Basin/Outfall Area No.	1
Total drainage basin/outfall area	3.19 acres
Predevelopment impervious area within drainage basin/outfall area	0.14 acres
Post-development impervious area within drainage basin/outfall area	0.23 acres
Post-development impervious fraction within drainage basin/outfall area	0.17
$L_{TSS, basin}$	300 lbs.

3. Indicate the proposed BMP Code for this basin:

Proposed BMP	Vegetated Filter Strips
Removal efficiency	85 percent

Available Cartridge Filter
Biosand
Conical Sandbar
Constructed Wetland
Extended Detention
Grassy Swale
Retention / Infiltration
Sand Filter
Stormwater
Vegetated Filter Strips
Vortex
Wet Basin
Wet Pond

4. Calculate Maximum TSS Load Removed (L_{TSS}) for the Drainage Basin by the selected BMP Type

RG-348 Page 3-33 Equation 5.7: $L_{TSS} = (BMP \text{ efficiency}) \times P \times (A_{imp} + A_{p}) \times 0.54$

where:

- A_{imp} = Total On-Site drainage area in the BMP catchment area
- A_{p} = Impervious area proposed in the BMP catchment area
- A_{p} = Previous area remaining in the BMP catchment area
- L_{TSS} = TSS Load removed from the catchment area by the proposed BMP

A_{imp}	1.06 acres
A_{p}	0.33 acres
A_{p}	1.33 acres
L_{TSS}	330 lbs.

5. Calculate Fraction of Annual Rainfall to Treat the drainage basin /outfall area

Desired L_{TSS} (lbs/ann) = 300 lbs.

$F = 0.85$

Calculations from RG-348 Pages 3-34 to 3-36

6. Calculate Capture Volume required by the BMP Type for this drainage basin /outfall area.

Calculations from RG-348 Pages 3-36 to 3-37

Rainfall Depth	0.87 inches
Post-Development Runoff Coefficient	0.25
On-Site Water Quality Volume	1139 cubic feet

Off-site area draining to BMP = 1.30 acres
Off-site impervious cover draining to BMP = 0.00 acres
Impervious fraction of off-site area = 0.00
On-Site Runoff Coefficient = 0.02
Off-site Water Quality Volume = 65 cubic feet

Total Capture Volume (required water quality volume) = 241 cubic feet
The following sections are used to calculate the required water quality volume(s) for the selected BMP.

10. Vegetated Filter Strips
Designed as Required in RG-348 Pages 3-55 to 3-57

There are no calculations required for determining the load or size of vegetative filter strips. The 80% removal is provided when the contributing drainage area does not exceed 72 feet (direction of flow) and the sheet flow leaving the impervious cover is directed across 15 feet of vegetated filter strips with maximum slope of 20% or across 50 feet of natural vegetation with a maximum slope of 10%. There can be a break in grade as long as no slope exceeds 20%.

If vegetative filter strips are proposed for an interim permanent BMP, they may be sized as described on Page 3-56 of RG-348.

EVER ENGINEERING, LLC
ADVANCED ENGINEERING SERVICES

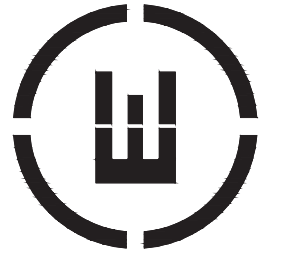

PROJECT LOCATION:
200 FM 32
SAN MARCOS, TEXAS 78666

DATE	
REVISIONS	

STORM WATER QUALITY SITE PLAN

PLAT NO.: TBD
DRAWN: CV
CHECKED: ROM
JOB NO.: 22-0106
DATE: OCT. 2022

STATE OF TEXAS
EVER GARZA III
127459
LICENSED PROFESSIONAL ENGINEER

SHEET: WO-1

GENERAL NOTES:

- ALL WORK SHALL BE PERFORMED IN ACCORDANCE WITH THESE PLANS. IN THE EVENT THAT A DESIGN ELEMENT DOES NOT REFLECT FIELD CONDITIONS, THE MATTER MUST BE IMMEDIATELY BROUGHT TO THE ATTENTION OF THE ENGINEER. THE ENGINEER SHALL BE RESPONSIBLE FOR RECOMMENDING A SOLUTION OR ALTERNATIVE SOLUTIONS FOR REVIEW AND APPROVAL PRIOR TO CONSTRUCTION COMMENCEMENT.
- THE APPROVAL OF A CONSTRUCTION PLAN DOES NOT RELIEVE THE CONTRACTOR FROM THE RESPONSIBILITY OF CONSTRUCTING WORKABLE IMPROVEMENTS. THE CONTRACTOR SHALL NOT MAKE ANY CHANGES OR ALTERATIONS TO THE PLANS. ALL REVISIONS AND/OR CORRECTIONS REQUIRED SHALL BE SUBMITTED TO THE PROJECT MANAGER AND SIGNED BY THE ENGINEER.
- ALL MATERIALS AND WORKMANSHIP SHALL BE SUBJECT TO INSPECTION BY THE ENGINEER. EVER ENGINEERING RESERVES THE RIGHT TO ACCEPT OR REJECT ANY SUCH MATERIALS AND WORKMANSHIP THAT DOES NOT CONFORM TO ITS STANDARDS AND SPECIFICATIONS.
- THE TYPE, SIZE, LOCATION, ELEVATION, AND NUMBER OF ALL KNOWN UNDERGROUND UTILITIES IN THE AREA OF CONSTRUCTION ARE SHOWN PER FIELD INVESTIGATION AND THE BEST AVAILABLE UTILITY RECORDS PROVIDED AND ARE APPROXIMATE ONLY. IT SHALL BE THE RESPONSIBILITY OF THE CONTRACTOR TO VERIFY THE EXISTENCE AND LOCATION OF ALL UNDERGROUND UTILITIES ALONG THE ROUTE OF WORK AND TO COORDINATE CONSTRUCTION SCHEDULES WITH THE UTILITY OWNERS AND TO SCHEDULE UTILITY ADJUSTMENTS TO ELIMINATE CONFLICT WITH PROGRESS OF THE WORK. IT IS THE RESPONSIBILITY OF THE CONTRACTOR TO IMMEDIATELY CONTACT THE ENGINEER IF SUCH CONFLICTS ARISE. THE CONTRACTOR SHALL NOTE ALL UTILITIES MAY NOT APPEAR ON THESE PLANS AND THAT THE POTENTIAL CONFLICT WITH UTILITIES SHALL BE CONSIDERED IN THE PREPARATION OF ANY BID. THE CONTRACTOR SHALL BE RESPONSIBLE FOR THE PROTECTION OF ALL UTILITIES WHETHER SHOWN ON THE PLANS OR NOT AND SHALL HOLD THE OWNERS AND THE ENGINEER HARMLESS FOR DAMAGE ARISING FROM FAILURE TO ADEQUATELY PROTECT UTILITIES.
- CONTRACTOR SHALL HAVE ONE (1) SIGNED COPY OF THE APPROVED PLANS AND CONSTRUCTION STANDARDS AT THE JOB SITE AT ALL TIMES. THE CONTRACTOR SHALL MAINTAIN AN AS BUILT REDLINE SET OF PLANS ON THE SITE AT ALL TIMES. THESE DRAWINGS, AND ANY REQUIRED PERMITS, SHALL BE MADE AVAILABLE UPON REQUEST. IF CONSTRUCTION PLANS ARE NOT READILY AVAILABLE AT THE PROJECT SITE, A STOP WORK ORDER MAY BE ISSUED PENDING COMPLIANCE BY THE CONTRACTOR.
- CONTRACTOR AGREES THAT HE SHALL ASSUME SOLE AND COMPLETE RESPONSIBILITY FOR JOB SITE CONDITIONS DURING THE COURSE OF PROJECT CONSTRUCTION, INCLUDING SAFETY OF ALL PERSONS AND PROPERTY. THIS REQUIREMENT SHALL APPLY CONTINUOUSLY AND NOT BE LIMITED TO NORMAL WORKING HOURS AND THAT THE CONTRACTOR SHALL DEFEND, INDEMNIFY AND HOLD HARMLESS FROM ALL LIABILITY, REAL OR ALLEGED, IN CONNECTION WITH THE PERFORMANCE OF WORK, ON THIS PROJECT, EXCEPT FOR LIABILITY ARISING FROM THE SOLE NEGLIGENCE OF THE ENGINEER.
- THE CONTRACTOR SHALL NOTIFY THE ENGINEER IMMEDIATELY OF ANY FIELD CONDITION NOT CONSISTENT WITH THE CONTRACT DOCUMENTS.
- CONTRACTOR SHALL USE EXTREME CAUTION AROUND ELECTRICAL DUCTS, TELECOMMUNICATION LINES, DITCH IRRIGATION LATERALS AND WATER MAINS TO INSURE THAT THESE AND ALL UTILITIES ARE PROTECTED FROM DAMAGE DURING CONSTRUCTION.
- ANY EXISTING MONITORING WELLS, CLEANOUTS, VALVE BOXES, MANHOLES, ETC. ARE TO BE PROTECTED AND TO REMAIN IN SERVICE. IF FEATURES EXIST, EXTEND OR LOWER TO THE FINAL SURFACE WITH LIKE KIND CAP WITH STANDARD CAST ACCESS LID WITH SAME MARKINGS.
- CONTRACTOR SHALL BE RESPONSIBLE FOR REMOVING AND REPLACING ANY EXISTING SIGNS, STRUCTURES, FENCES, ETC. ENCOUNTERED ON THE PROJECT AND RESTORING THEM TO THEIR PRE-CONSTRUCTION CONDITION.
- STAGING AREAS FOR MATERIALS AND/OR EQUIPMENT ARE NOT SHOWN. CONTRACTOR SHALL ACQUIRE APPROVAL OF STAGING AREAS.
- FINAL LIMITS OF REQUIRED ASPHALT AND/OR CONCRETE SAWCUT AND PATCHING MAY VARY FROM LIMITS SHOWN ON THE PLANS. THE CONTRACTOR IS TO PROVIDE SAWCUT AND PATCH WORK TO ACHIEVE POSITIVE DRAINAGE AND A SMOOTH TRANSITION TO EXISTING WITHIN ACCEPTABLE DRIVE SLOPE STANDARDS PER THE ENGINEER WITHOUT ADDITIONAL COST. THE CONTRACTOR SHALL PROVIDE ADDITIONAL SAW CUTTING AND PATCHING AS REQUIRED TO FACILITATE UTILITY WORK, ETC. THAT MAY NOT BE DELINEATED ON THE PLANS.
- CONTRACTOR SHALL PROVIDE A PLAN FOR TRAFFIC CONTROL (VEHICULAR AND PEDESTRIAN) DURING CONSTRUCTION AND SHALL BE RESPONSIBLE FOR ACQUIRING THE NECESSARY PERMITTING FOR CONSTRUCTION INCLUDING BUT NOT LIMITED TO RIGHT-OF-WAY PERMITS.
- CONTRACTOR SHALL PROVIDE SAFETY FENCING AS NECESSARY AROUND ENTIRE ACTIVE CONSTRUCTION SITE FOR ALL PHASES OF CONSTRUCTION DURING NON-WORKING HOURS. SAFETY FENCING SHALL BE A MINIMUM 5 FOOT HIGH CHAIN LINK FENCE OR APPROVED EQUIVALENT. CONTRACTOR SHALL ALSO PROVIDE PLATING ACROSS OPEN TRENCHES FOR ALL PHASES OF CONSTRUCTION DURING WEEKEND AND HOLIDAY NON-WORKING HOURS.
- WRITTEN DIMENSIONS ON THE PLANS AND DETAILS SHALL TAKE PRECEDENCE OVER SCALED DIMENSIONS.
- THE CONTRACTOR SHALL RESTORE ALL DISTURBED AREAS TO THEIR ORIGINAL CONDITION OR BETTER AS DESIGNATED BY THE OWNER/ENGINEER. THE CONTRACTOR SHALL INCLUDE THIS WORK IN HIS/HER BID.
- FOR ALL FACILITIES NOT SPECIFICALLY DESCRIBED ON THE DRAWINGS, CONTRACTOR SHALL RESTORE ANY AND ALL DISTURBED SURFACE FEATURES TO THEIR ORIGINAL LOCATION AND CONDITION PRIOR TO PROJECT COMPLETION.
- ALL SURPLUS MATERIALS, TOOLS AND TEMPORARY STRUCTURES, FURNISHED BY THE CONTRACTOR, SHALL BE REMOVED FROM THE PROJECT BY THE CONTRACTOR. ALL DEBRIS AND RUBBISH CAUSED BY THE OPERATIONS OF THE CONTRACTOR SHALL BE REMOVED, AND THE AREA OCCUPIED DURING CONSTRUCTION SHALL BE RESTORED TO ITS ORIGINAL CONDITION, WITHIN 48 HOURS OF PROJECT COMPLETION.
- THE CONTRACTOR SHALL BE RESPONSIBLE FOR ACCEPTANCE AND CONTROL OF ALL FLOWS INCLUDING SURFACE WATERS, STORM SEWER FLOWS, AND GROUNDWATER FLOWS DURING CONSTRUCTION.
- STORMWATER: THE CONTRACTOR IS NOT TO DISCHARGE ANY CONSTRUCTION WATER, WASTE OR DEBRIS INTO THE STORM WATER SYSTEM.
- THE CONTRACTOR IS REQUIRED TO PROVIDE AND MAINTAIN EROSION AND SEDIMENT CONTROL MEASURES THROUGHOUT THE DURATION OF THE PROJECT.
- STREET LIGHTS REQUIRING REMOVAL DURING CONSTRUCTION SHALL BE RESET BY CONTRACTOR UPON COMPLETION TO EXISTING CONDITION.
- ACCESS BY THE FIRE DEPARTMENT AND OTHER EMERGENCY RESPONDERS TO ALL BUILDINGS MUST REMAIN UNOBSTRUCTED AT ALL TIMES.
- THESE NOTES APPLY TO ALL SHEETS INCLUDED WITH THIS SET OF PLANS

SAVAGE LAND SOLUTIONS

SAN MARCUS, TEXAS

CIVIL PERMIT SET

SHEET INDEX

Sheet Description	Sheet No.
COVER SHEET	C0.00
OVERALL SITE PLAN	C1.00
STORMWATER POLLUTION PREVENTION PLAN	C2.00
STORMWATER POLLUTION PREVENTION DETAILS	C2.10
FIRE PROTECTION PLAN	C3.00
DEMOLITION PLAN	C4.00
DIMENSIONAL CONTROL PLAN	C5.00
UTILITY PLAN	C6.00
UTILITY DETAILS	C6.10
GRADING PLAN	C7.00
ONSITE DRAINAGE PLAN	C8.00
CIVIL DETAILS	C9.00
WATER POLLUTION ABATEMENT PLAN	WQ-1

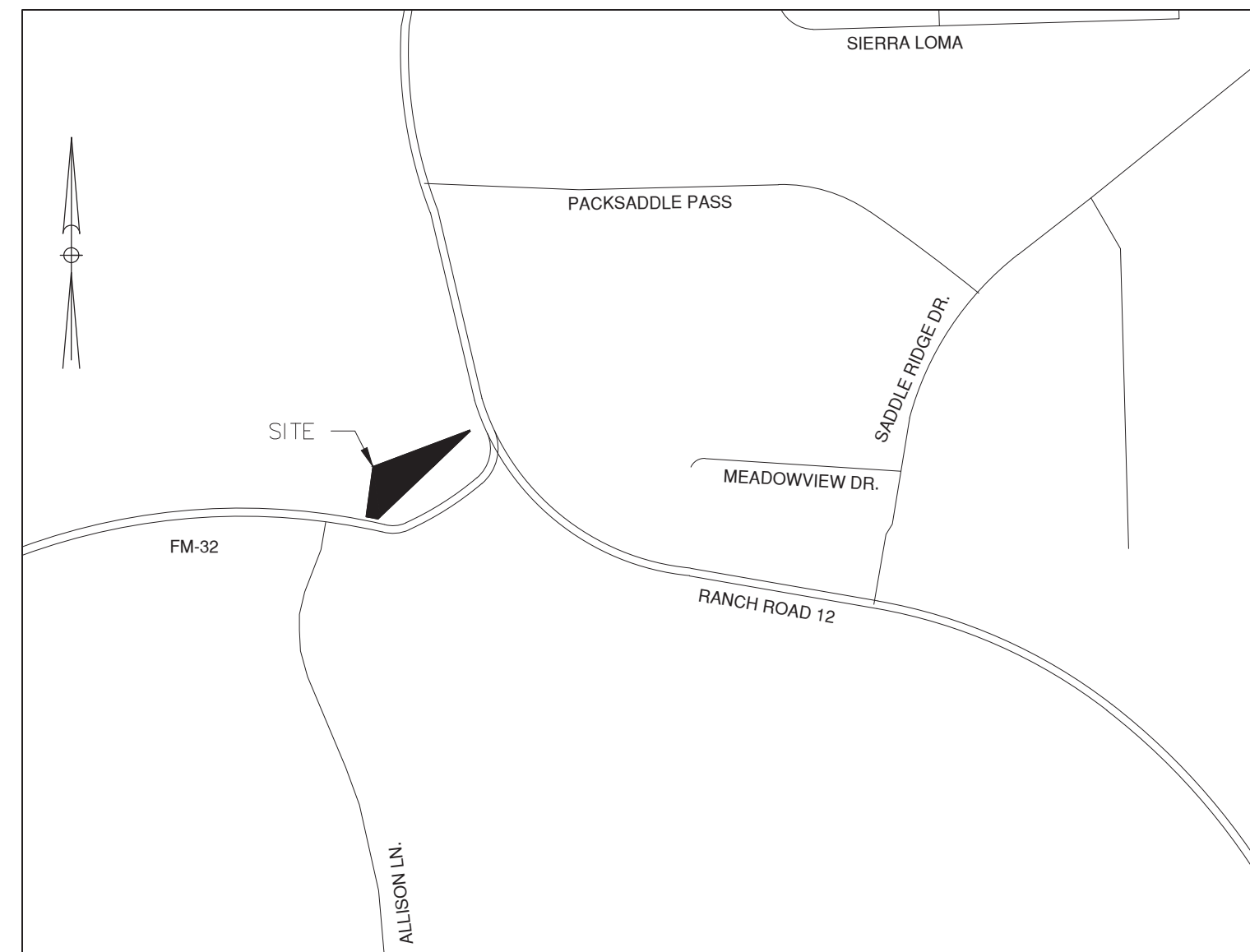

LOCATION MAP
NOT-TO-SCALE

PREPARED FOR:

SAVAGE LAND SOLUTIONS
P.O. BOX 1113
SAN MARCOS, TX 78666
DECEMBER 2022



EVER ENGINEERING, LLC
ADVANCED ENGINEERING SERVICES

3201 CHERRY RIDGE DRIVE, SUITE A-106,
SAN ANTONIO, TX 78230
OFFICE (210) 572-9340 FAX (210) 572-9344
WWW.EVERENC.COM

NO.	DATE	DESCRIPTION	BY

CALL BEFORE YOU DIG!

Texas 811

811 PARTICIPANTS REQUEST 48 HOURS NOTICE BEFORE YOU DIG, DRILL, OR BLAST - STOP AND CALL

THE LONE STAR NOTIFICATION COMPANY
AT 1-800-669-8344

LEGAL DESCRIPTION

1.8558-ACRE TRACT
ABS 25
JAMES ALSTON SURVEY

SAVAGE LAND SOLUTIONS HO

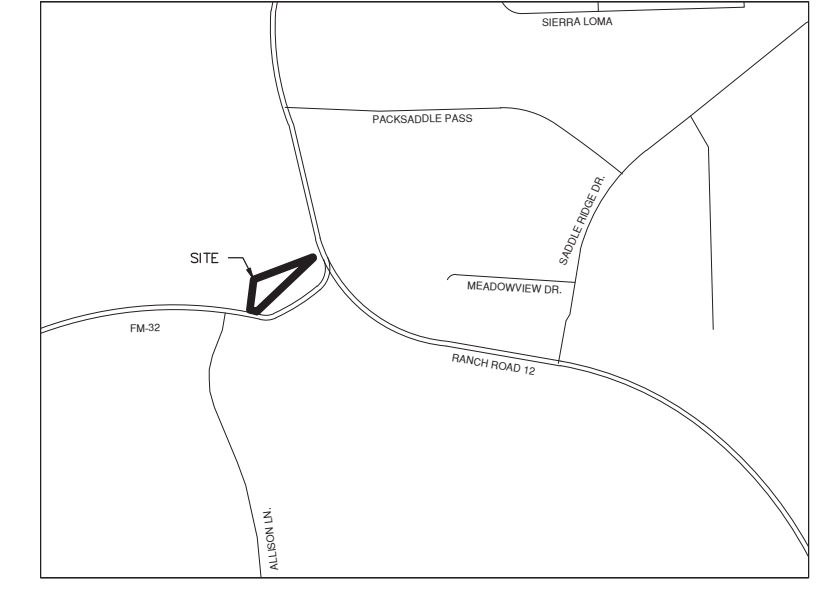

LOCATION MAP
NOT-TO-SCALE

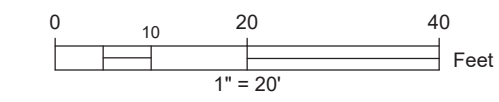
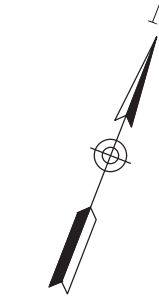

LEGEND

- PROPERTY LINE ————
- ADJACENT PROPERTY LINE - - - - -
- EXISTING EASEMENT - - - - -
- PROPOSED EASEMENT - - - - -

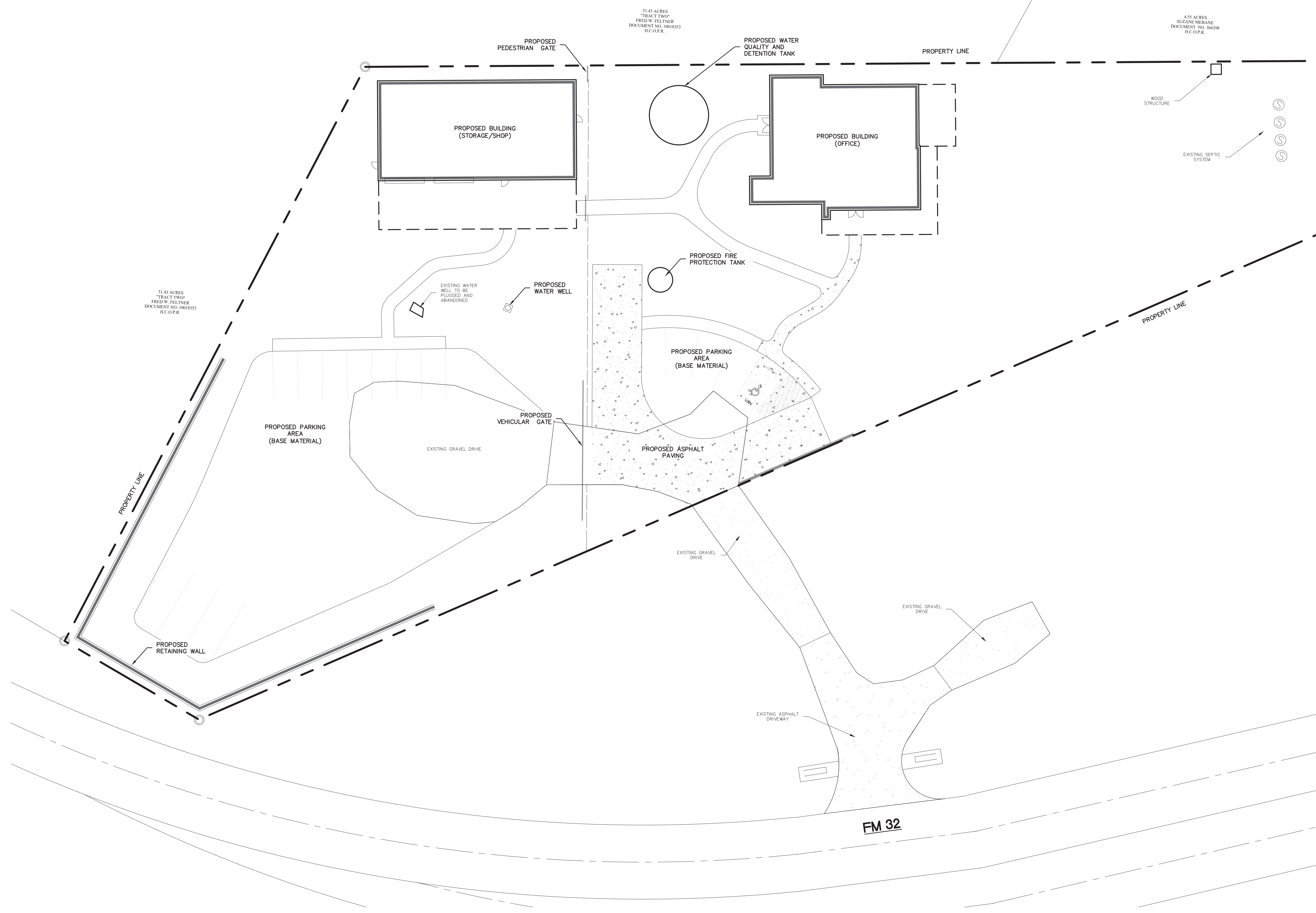

EVER ENGINEERING, LLC
 ADVANCED ENGINEERING SERVICES
 3201 CHERRY RIDGE DRIVE, SUITE A-106,
 SAN ANTONIO, TX 78230
 OFFICE (210) 572-9340, FAX (210) 572-9344
 WWW.EVERENG.COM, WWW.AES-TX.COM
 REG. NO. F-19197



PROJECT LOCATION:
 200 FM 32
 SAN MARCOS, TEXAS 78666

DATE	REVISIONS

OVERALL SITE PLAN

PLAT NO.: TBD
 DRAWN: GY
 CHECKED: RDM
 JOB NO.: 22-0106
 DATE: DEC. 2022

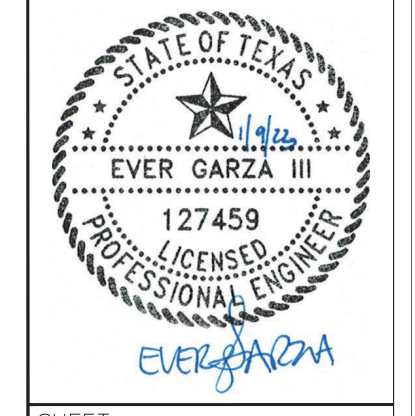

SHEET: C1.00

LEGAL DESCRIPTION

1.8558-ACRE TRACT
ABS 25
JAMES ALSTON SURVEY

SWP3 MODIFICATIONS

DATE	SIGNATURE	DESCRIPTION

SAVAGE LAND SOLUTIONS HO

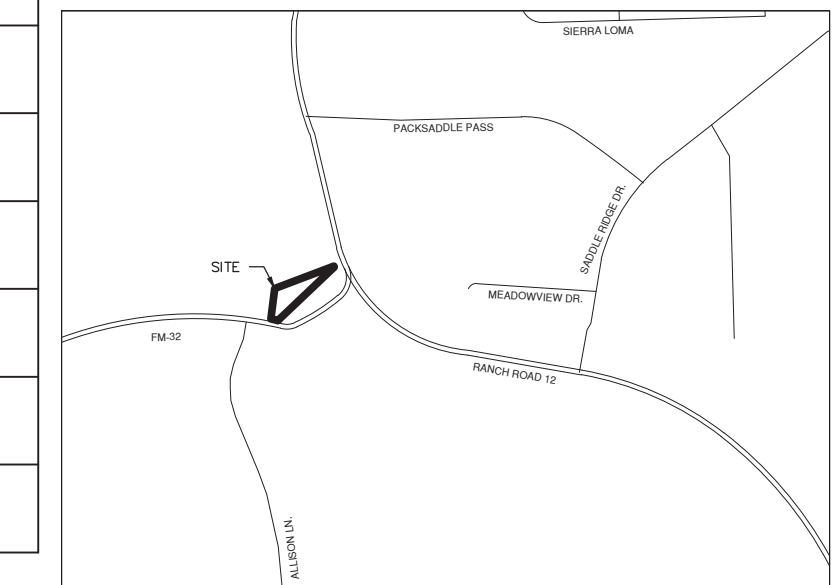

LOCATION MAP
NOT-TO-SCALE

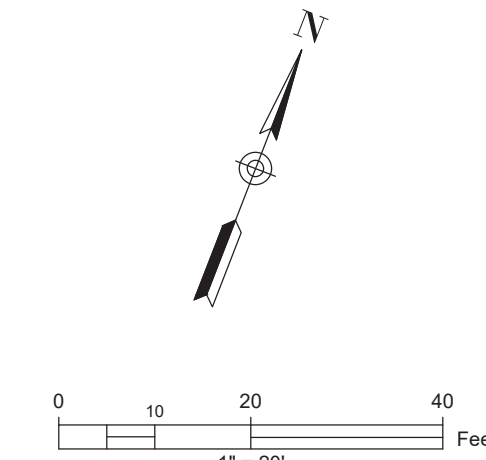

LEGEND

- PROPERTY LINE
- LIMITS OF DISTURBED AREA (1.53-ACRES)
- EXISTING CONTOUR
- PROPOSED CONTOUR
- FLOW ARROW (EXISTING)
- FLOW ARROW (PROPOSED)
- STABILIZED CONSTRUCTION ENTRANCE (FIELD LOCATE)
- CONCRETE TRUCK WASHOUT (FIELD LOCATE)
- CONSTRUCTION STAGING AREA (FIELD LOCATE)
- SILT FENCE
- ROCK BERM
- INLET PROTECTION
- GRAVEL FILTER BAGS

GENERAL NOTES

1. DO NOT DISTURB VEGETATED AREAS (TREES, GRASS, WEEDS, BRUSH, ETC.) ANY MORE THAN NECESSARY FOR CONSTRUCTION.
2. CONSTRUCTION ENTRANCE/EXIT LOCATION, CONCRETE WASH-OUT PIT, AND CONSTRUCTION EQUIPMENT AND MATERIAL STORAGE YARD TO BE DETERMINED IN THE FIELD.
3. STORM WATER POLLUTION PREVENTION CONTROLS MAY NEED TO BE MODIFIED IN THE FIELD TO ACCOMPLISH THE DESIRED EFFECT. ALL MODIFICATIONS ARE TO BE NOTED ON THIS EXHIBIT AND SIGNED AND DATED BY THE RESPONSIBLE PARTY.
4. RESTRICT ENTRY/EXIT TO THE PROJECT SITE TO DESIGNATED LOCATIONS BY USE OF ADEQUATE FENCING, IF NECESSARY.
5. ALL STORM WATER POLLUTION PREVENTION CONTROLS ARE TO BE MAINTAINED AND IN WORKING CONDITIONS AT ALL TIMES.
6. STORM WATER POLLUTION PREVENTION STRUCTURES SHOULD BE CONSTRUCTED WITHIN THE SITE BOUNDARIES. SOME OF THESE FEATURES MAY BE SHOWN OUTSIDE THE SITE BOUNDARIES ON THIS PLAN FOR VISUAL CLARITY.
7. AS SOON AS PRACTICAL, ALL DISTURBED SOIL THAT WILL NOT BE COVERED BY IMPERVIOUS COVER SUCH AS PARKWAY AREAS, EASEMENT AREAS, EMBANKMENT SLOPES, ETC. WILL BE STABILIZED PER APPLICABLE PROJECT SPECIFICATIONS.
8. BEST MANAGEMENT PRACTICES MAY BE INSTALLED IN STAGES TO COINCIDE WITH THE DISTURBANCE OF UPGRADIENT AREAS.
9. BEST MANAGEMENT PRACTICES MAY BE REMOVED IN STAGES ONCE THE WATERSHED FOR THAT PORTION CONTROLLED BY THE BEST MANAGEMENT PRACTICES HAS BEEN STABILIZED IN ACCORDANCE WITH TPDES REQUIREMENTS.
10. UPON COMPLETION OF THE PROJECT, INCLUDING SITE STABILIZATION, AND BEFORE FINAL PAYMENT IS ISSUED, CONTRACTOR SHALL REMOVE ALL SEDIMENT & EROSION CONTROL MEASURES, PAYING SPECIAL ATTENTION TO ROCK BERMS IN DRAINAGE FEATURES.
11. WHERE VEGETATED FILTER STRIPS ARE INDICATED, CONTRACTOR SHALL VERIFY THAT SUFFICIENT VEGETATION EXISTS, OTHERWISE CONTRACTOR SHALL PLACE SILT FENCING IN LIEU OF VEGETATED FILTER STRIP.
12. SHADED AREA DENOTES LIMITS OF DISTURBED AREAS. OTHER AREAS WITHIN THE PROJECT LIMITS, WITH THE EXCEPTION OF A CONSTRUCTION EQUIPMENT AND MATERIAL STORAGE YARD, ARE NOT A PART OF THIS TPDES STORM WATER POLLUTION PREVENTION PLAN (SWP3) AND WILL NOT BE DISTURBED BY CIVIL CONSTRUCTION ACTIVITIES. HOUSE CONSTRUCTION ACTIVITIES WILL REQUIRE A SEPARATE STORM WATER POLLUTION PREVENTION PLAN.
13. TEMPORARY SEDIMENT BASIN AND INTERCEPTOR BERM MUST BE CONSTRUCTED PRIOR TO MASS GRADING TO CONTROL SEDIMENT FROM GRADING OPERATIONS.

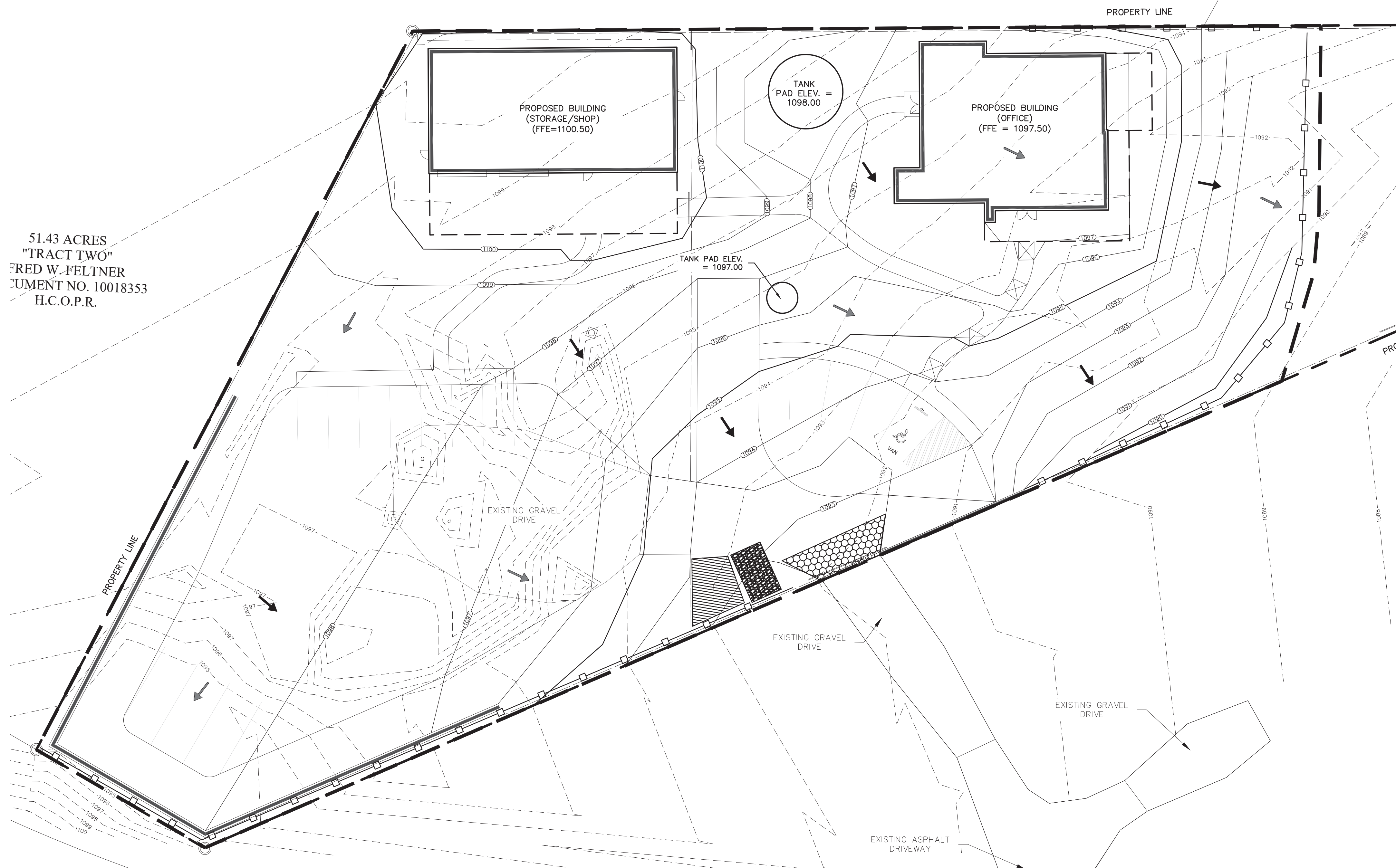

51.43 ACRES
"TRACT TWO"
FRED W. FELTNER
DOCUMENT NO. 10018353
H.C.O.P.R.

THE ENGINEERING SEAL HAS BEEN AFFIXED TO THIS SHEET ONLY FOR THE PURPOSE OF DEMONSTRATING COMPLIANCE WITH THE TPDES-STORM WATER POLLUTION PREVENTION PLAN (SWP3) REGULATIONS.

THIS SHEET HAS BEEN PREPARED FOR PURPOSES OF THE SWP3 ONLY. ALL OTHER CIVIL ENGINEERING RELATED INFORMATION SHOULD BE ACQUIRED FROM THE APPROPRIATE SHEET IN THE CIVIL IMPROVEMENT PLANS.

EVER ENGINEERING, LLC
ADVANCED ENGINEERING SERVICES
3201 CHERRY RIDGE DRIVE, SUITE A-106,
SAN ANTONIO, TX 78230
OFFICE (210) 572-9340 FAX (210) 572-9344
WWW.EVERENG.COM WWW.AES-TX.COM
FORM NO. E-18197



PROJECT LOCATION:
200 FM 32
SAN MARCOS, TEXAS 78666

STORMWATER POLLUTION PREVENTION PLAN

PLAT NO.: TBD
DRAWN: CV
CHECKED: ROM
JOB NO.: 22-0106
DATE: DEC. 2022

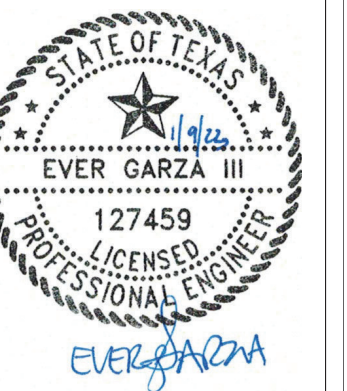

SHEET:
C2.00

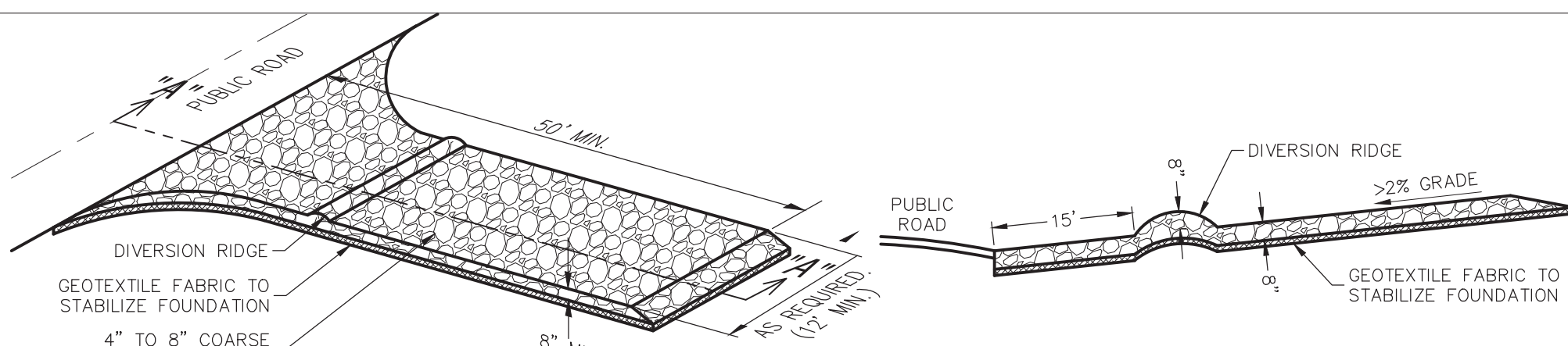

SCHEMATIC OF TEMPORARY CONSTRUCTION ENTRANCE/EXIT

MATERIALS

1. THE AGGREGATE SHOULD CONSIST OF 4-INCH TO 8-INCH WASHED STONE OVER A STABLE FOUNDATION AS SPECIFIED IN THE PLAN.
2. THE AGGREGATE SHOULD BE PLACED WITH A MINIMUM THICKNESS OF 8-INCHES.
3. THE GEOTEXTILE FABRIC SHOULD BE DESIGNED SPECIFICALLY FOR USE AS A SOIL FILTRATION MEDIA WITH AN APPROXIMATE WEIGHT OF 6 OZ/YD², A MULLEN BURST RATING OF 140 LB/IN², AND AN EQUIVALENT OPENING SIZE GREATER THAN A NUMBER 50 SIEVE.
4. IF A WASHING FACILITY IS REQUIRED, A LEVEL AREA WITH A MINIMUM OF 4-INCH DIAMETER WASHED STONE OR COMMERCIAL ROCK SHOULD BE INCLUDED IN THE PLANS. DIVERT WASTEWATER TO A SEDIMENT TRAP OR BASIN.

INSTALLATION

1. AVOID CURVES ON PUBLIC ROADS AND STEEP SLOPES. REMOVE VEGETATION AND OTHER OBSTRUCTIONABLE MATERIAL FROM THE FOUNDATION AREA. GRADE CROWN FOUNDATION FOR POSITIVE DRAINAGE.
2. THE MINIMUM WIDTH OF THE ENTRANCE/EXIT SHOULD BE 12 FEET OR THE FULL WIDTH OF EXIT ROADWAY, WHICHEVER IS GREATER.
3. THE CONSTRUCTION ENTRANCE SHOULD BE AT LEAST 50 FEET LONG.
4. IF THE SLOPE TOWARD THE ROAD EXCEEDS 2%, CONSTRUCT A RIDGE, 6-INCHES TO 8-INCHES HIGH WITH 3:1 (H:V) SIDE SLOPES, ACROSS THE FOUNDATION APPROXIMATELY 15 FEET FROM THE ENTRANCE TO DIVERT RUNOFF AWAY FROM THE PUBLIC ROAD.
5. PLACE GEOTEXTILE FABRIC AND GRADE FOUNDATION TO IMPROVE STABILITY, ESPECIALLY WHERE WET CONDITIONS ARE ANTICIPATED.
6. PLACE STONE TO DIMENSIONS AND GRADE SHOWN ON PLANS. LEAVE SURFACE SMOOTH AND SLOPE FOR DRAINAGE.
7. DIVERT ALL SURFACE RUNOFF AND DRAINAGE FROM THE STONE PAD TO A SEDIMENT TRAP OR BASIN.
8. INSTALL PIPE UNDER PAD AS NEEDED TO MAINTAIN PROPER PUBLIC ROAD DRAINAGE.

STABILIZED CONSTRUCTION ENTRANCE/EXIT DETAIL

NOT-TO-SCALE

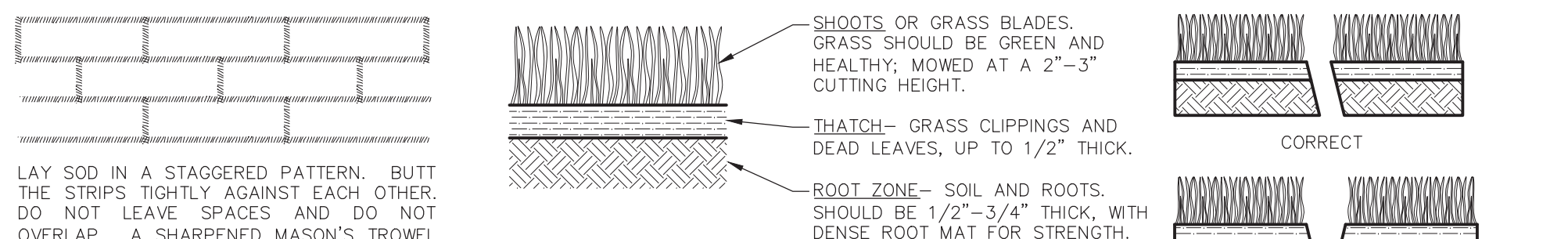

APPEARANCE OF GOOD SOD

- NOTES:
1. ROLL SOD IMMEDIATELY TO ACHIEVE FIRM CONTACT WITH THE SOIL.
 2. WATER TO A DEPTH OF 4" AS NEEDED. WATER WELL AS SOON AS THE SOD IS LAID.
 3. MOW WHEN THE SOD IS ESTABLISHED - IN 2-3 WEEKS. SET THE MOWER HIGH (2"-3").

LAY SOD IN A STAGGERED PATTERN, BUTT THE STRIPS TIGHTLY AGAINST EACH OTHER. DO NOT LEAVE SPACES AND DO NOT OVERLAP. A SHARPENED MASON'S TROWEL IS A HANDY TOOL FOR TUCKING DOWN THE ENDS AND TRIMMING PIECES.

BUTTING - ANGLED ENDS CAUSED BY THE AUTOMATIC SOD CUTTER MUST BE MATCHED CORRECTLY.

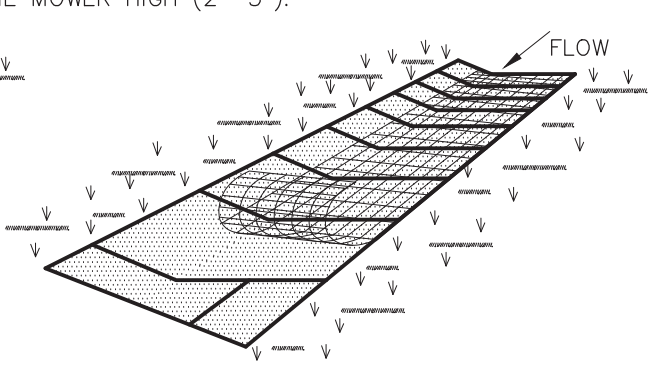
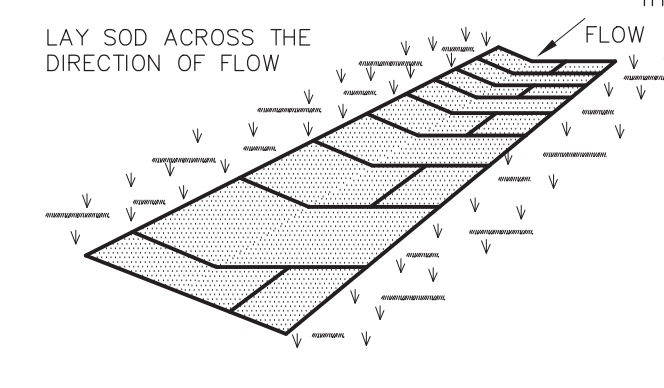

USE PEGS OR STAPLES TO FASTEN SOD FIRMLY - AT THE ENDS OF STRIPS AND IN THE CENTER, OR EVERY 3-4 FEET IF THE STRIPS ARE LONG. WHEN READY TO MOW, DRIVE PEGS OR STAPLES FLUSH WITH THE GROUND.

MATERIALS

1. SOD SHOULD BE MACHINE CUT AT A UNIFORM SOIL THICKNESS OF 3/4" INCH (± 1/4" INCH) AT THE TIME OF CUTTING. THIS THICKNESS SHOULD EXCLUDE SHOOT GROWTH AND THATCH.
2. PIECES OF SOD SHOULD BE CUT TO THE SUPPLIER'S STANDARD WIDTH AND LENGTH, WITH A MAXIMUM ALLOWABLE DEVIATION IN ANY DIMENSION OF 5%. TORN OR UNEVEN PADS SHOULD NOT BE ACCEPTABLE.
3. STANDARD SIZE SECTIONS OF SOD SHOULD BE STRONG ENOUGH TO SUPPORT THEIR OWN WEIGHT AND RETAIN THEIR SIZE AND SHAPE WHEN SUSPENDED FROM A FIRM GRASP ON ONE END OF THE SECTION.
4. SOD SHOULD BE HARVESTED, DELIVERED, AND INSTALLED WITHIN A PERIOD OF 36 HOURS.

SITE PREPARATION

1. PRIOR TO SOIL PREPARATION, AREAS TO BE SODDED SHOULD BE BROUGHT TO FINAL GRADE IN ACCORDANCE WITH THE APPROVED PLAN.
2. THE SURFACE SHOULD BE CLEARED OF ALL TRASH, DEBRIS AND OF ALL ROOTS, BRUSH, WIRE, GRADE STAKES AND OTHER OBJECTS THAT WOULD INTERFERE WITH PLANTING, FERTILIZING OR MAINTENANCE OPERATIONS.
3. FERTILIZE ACCORDING TO SOIL TESTS. FERTILIZER NEEDS CAN BE DETERMINED BY A SOIL TESTING LABORATORY OR REGIONAL RECOMMENDATIONS CAN BE MADE BY COUNTY AGRICULTURAL EXTENSION AGENTS. FERTILIZER SHOULD BE WORKED INTO THE SOIL TO A DEPTH OF 3 INCHES WITH A DISC, SPRINGTOOTH HARROW OR OTHER SUITABLE EQUIPMENT, ON SLOPING LAND, THE FINAL HARROWING OR DISCING OPERATION SHOULD BE ON THE CONTOUR.

INSTALLATION IN CHANNELS

1. SOD STRIPS IN WATERWAYS SHOULD BE LAID PERPENDICULAR TO THE DIRECTION OF FLOW. CARE SHOULD BE TAKEN TO BUTT ENDS OF STRIPS TIGHTLY (SEE FIGURE ABOVE).
2. AFTER ROLLING OR TAMPING, SOD SHOULD BE PEGGED OR STAPLED TO RESIST WASHOUT DURING THE ESTABLISHMENT PERIOD. MESH OR OTHER NETTING MAY BE PEGGED OVER THE SOD FOR EXTRA PROTECTION IN CRITICAL AREAS.

SOD INSTALLATION DETAIL

NOT-TO-SCALE

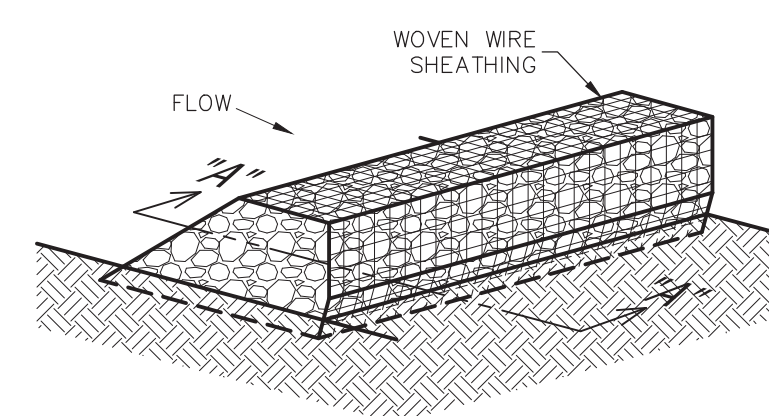

ISOMETRIC PLAN VIEW

ROCK BERMS

THE PURPOSE OF A ROCK BERM IS TO SERVE AS A CHECK DAM IN AREAS OF CONCENTRATED FLOW, TO INTERCEPT SEDIMENT-LADEN RUNOFF, DETAIN THE SEDIMENT AND RELEASE THE WATER IN SHEET FLOW. THE ROCK BERM SHOULD BE USED WHEN THE CONTRIBUTING DRAINAGE AREA IS LESS THAN 5 ACRES. ROCK BERMS ARE USED IN AREAS WHERE THE VOLUME OF RUNOFF IS TOO GREAT FOR A SILT FENCE TO CONTAIN. THEY ARE LESS EFFECTIVE FOR SEDIMENT REMOVAL THAN SILT FENCES, PARTICULARLY FOR FINE PARTICLES, BUT ARE ABLE TO WITHSTAND HIGHER FLOWS THAN A SILT FENCE. AS SUCH, ROCK BERMS ARE OFTEN USED IN AREAS OF CHANNEL FLOWS (DITCHES, GULLIES, ETC.). ROCK BERMS ARE MOST EFFECTIVE AT REDUCING BERD LOAD IN CHANNELS AND SHOULD NOT BE SUBSTITUTED FOR OTHER EROSION AND SEDIMENT CONTROL MEASURES FARTHER UP THE WATERSHED.

INSPECTION AND MAINTENANCE GUIDELINES

1. INSPECTION SHOULD BE MADE WEEKLY AND AFTER EACH RAINFALL, BY THE RESPONSIBLE PARTY. FOR INSTALLATIONS IN STREAMBEDS, ADDITIONAL DAILY INSPECTIONS SHOULD BE MADE.
2. REMOVE SEDIMENT AND OTHER DEBRIS WHEN BUILDUP REACHES 6 INCHES AND DISPOSE OF THE ACCUMULATED SILT IN AN APPROVED MANNER THAT WILL NOT CAUSE ANY ADDITIONAL SILTATION.
3. REPAIR ANY LOOSE WIRE SHEATHING.
4. THE BERM SHOULD BE RESHAPED AS NEEDED DURING INSPECTION.
5. THE BERM SHOULD BE REPLACED WHEN THE STRUCTURE CEASES TO FUNCTION AS INTENDED DUE TO SILT ACCUMULATION AMONG THE ROCKS, WASHOUT, CONSTRUCTION TRAFFIC DAMAGE, ETC.
6. THE ROCK BERM SHOULD BE LEFT IN PLACE UNTIL ALL UPSTREAM AREAS ARE STABILIZED AND ACCUMULATED SILT REMOVED.

ROCK BERM DETAIL

NOT-TO-SCALE

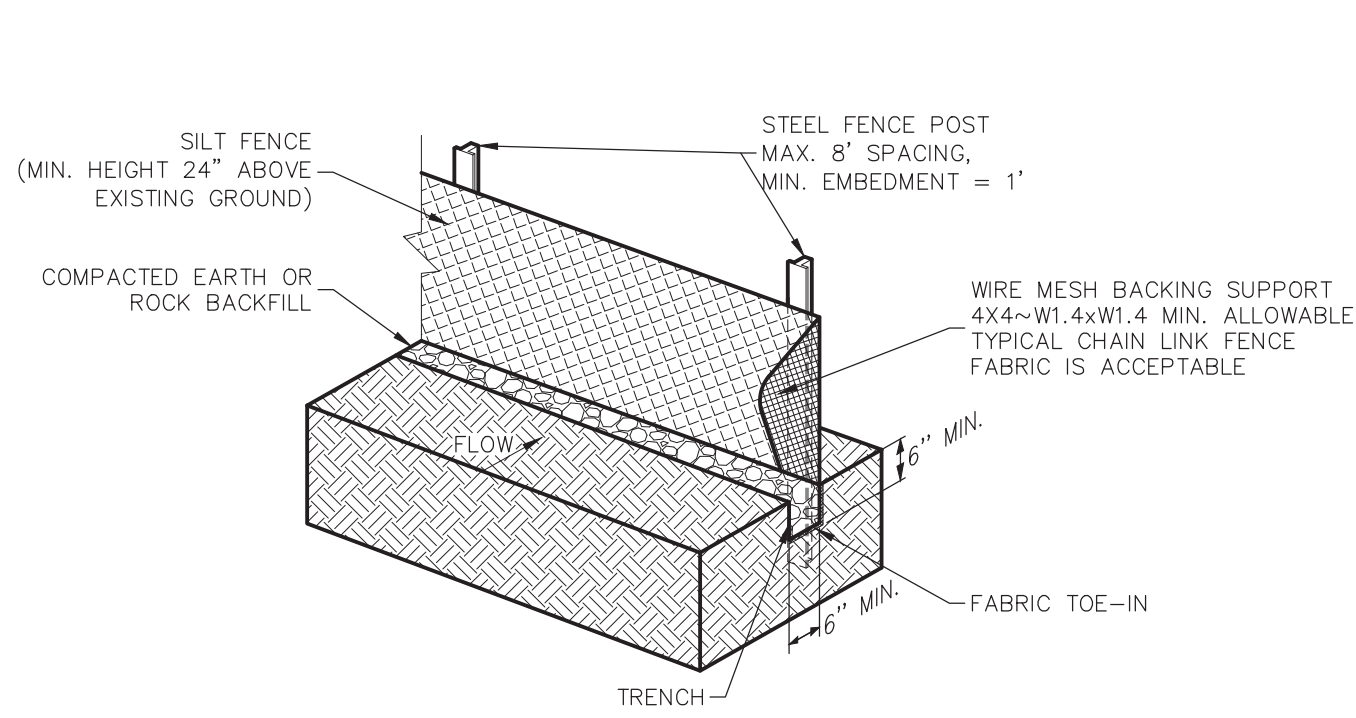

ISOMETRIC PLAN VIEW

SILT FENCE

A SILT FENCE IS A BARRIER CONSISTING OF GEOTEXTILE FABRIC SUPPORTED BY METAL POSTS TO PREVENT SOIL AND SEDIMENT LOSS FROM A SITE. WHEN PROPERLY USED, SILT FENCES CAN BE HIGHLY EFFECTIVE AT CONTROLLING SEDIMENT FROM DISTURBED AREAS. THEY CAUSE RUNOFF TO POND, ALLOWING HEAVIER SOLIDS TO SETTLE OUT. IF NOT PROPERLY INSTALLED, SILT FENCES ARE NOT LIKELY TO BE EFFECTIVE.

THE PURPOSE OF A SILT FENCE IS TO INTERCEPT AND DETAIN WATER-BORN SEDIMENT FROM UNPROTECTED AREAS OF A LIMITED EXTENT. SILT FENCE IS USED DURING THE PERIOD OF CONSTRUCTION NEAR THE PERIMETER OF A DISTURBED AREA TO INTERCEPT SEDIMENT WHILE ALLOWING WATER TO PERCOLATE THROUGH. THIS FENCE SHOULD REMAIN IN PLACE UNTIL THE DISTURBED AREA IS PERMANENTLY STABILIZED. SILT FENCE SHOULD NOT BE USED WHERE THERE IS A CONCENTRATION OF WATER IN A CHANNEL OR DRAINAGE WAY. IF CONCENTRATED FLOW OCCURS AFTER INSTALLATION, CORRECTIVE ACTION MUST BE TAKEN SUCH AS PLACING A ROCK BERM IN THE AREAS OF CONCENTRATED FLOW.

SILT FENCING WITHIN THE SITE MAY BE TEMPORARILY MOVED DURING THE DAY TO ALLOW CONSTRUCTION ACTIVITY PROVIDED IT IS REPLACED AND PROPERLY ANCHORED TO THE GROUND AT THE END OF THE DAY. SILT FENCES ON THE PERIMETER OF THE SITE OR AROUND DRAINAGE WAYS SHOULD NOT BE MOVED AT ANY TIME.

MATERIALS

1. SILT FENCE MATERIAL SHOULD BE POLYPROPYLENE, POLYETHYLENE, OR POLYAMIDE WOVEN OR NONWOVEN FABRIC. THE FABRIC SHOULD BE 36 INCHES, WITH A MINIMUM UNIT WEIGHT OF 4.5 OZ/YD, MULLEN BURST STRENGTH EXCEEDING 190 LB/IN², ULTRAVIOLET STABILITY EXCEEDING 70%, AND MINIMUM APPARENT OPENING SIZE OF U.S. SIEVE NUMBER 30.
2. FENCE POSTS SHOULD BE MADE OF HOT ROLLED STEEL, AT LEAST 4 FEET LONG WITH TEE OR Y-BAR CROSS SECTION, SURFACE PAINTED OR GALVANIZED, MINIMUM WEIGHT 1.25 LB/FT, AND BRINDLE HARDNESS EXCEEDING 140.
3. WOVEN WIRE BACKING TO SUPPORT THE FABRIC SHOULD BE GALVANIZED 2" X 4" WELDED WIRE, 12 GAUGE MINIMUM.

INSTALLATION

1. STEEL POSTS, WHICH SUPPORT THE SILT FENCE, SHOULD BE INSTALLED ON A SLIGHT ANGLE TOWARD THE ANTICIPATED RUNOFF SOURCE. POSTS MUST BE EMBEDDED A MINIMUM OF 1-FOOT DEEP AND SPACED NOT MORE THAN 8 FEET ON CENTER, WHERE WATER CONCENTRATES, THE MAXIMUM SPACING SHOULD BE 6 FEET.
2. LAY OUT FENCING DOWN-SLOPE OF DISTURBED AREA, FOLLOWING THE CONTOUR AS CLOSELY AS POSSIBLE. THE FENCE SHOULD BE SITED SO THAT THE MAXIMUM DRAINAGE AREA IS 1/4 ACRE/100 FEET OF FENCE.

SILT FENCE DETAIL

NOT-TO-SCALE

MATERIALS

1. THE BERM STRUCTURE SHOULD BE SECURED WITH A WOVEN WIRE SHEATHING HAVING MAXIMUM OPENING OF 1 INCH AND A MINIMUM WIRE DIAMETER OF 20 GAUGE GALVANIZED AND SHOULD BE SECURED WITH SHOAT RINGS.
2. CLEAN, OPEN GRADED 3-INCH TO 5-INCH DIAMETER ROCK SHOULD BE USED, EXCEPT IN AREAS WHERE HIGH VELOCITIES OR LARGE VOLUMES OF FLOW ARE EXPECTED, WHERE 5-INCH TO 8-INCH DIAMETER ROCKS MAY BE USED.

INSTALLATION

1. LAY OUT THE WOVEN WIRE SHEATHING PERPENDICULAR TO THE FLOW LINE. THE SHEATHING SHOULD BE 20 GAUGE WOVEN WIRE MESH WITH 1 INCH OPENINGS.
2. BERM SHOULD HAVE A TOP WIDTH OF 2 FEET MINIMUM WITH SIDE SLOPES BEING 2:1 (H:V) OR FLATTER.
3. PLACE THE ROCK ALONG THE SHEATHING AS SHOWN IN THE DIAGRAM TO A HEIGHT NOT LESS THAN 18".
4. WRAP THE WIRE SHEATHING AROUND THE ROCK AND SECURE WITH THE WIRE SO THAT THE ENDS OF THE SHEATHING OVERLAP AT LEAST 2 INCHES, AND THE BERM RETAINS ITS SHAPE WHEN WALKED UPON.
5. BERM SHOULD BE BUILT ALONG THE CONTOUR AT ZERO PERCENT GRADE OR AS NEAR AS POSSIBLE.
6. THE ENDS OF THE BERM SHOULD BE TIED INTO EXISTING UPSLOPE GRADE AND THE BERM SHOULD BE BURIED IN A TRENCH APPROXIMATELY 3 TO 4 INCHES DEEP TO PREVENT FAILURE OF THE CONTROL.

COMMON TROUBLE POINTS

1. INSUFFICIENT BERM HEIGHT OR LENGTH (RUNOFF QUICKLY ESCAPES OVER THE TOP OR AROUND THE SIDES OF BERM).
2. BERM NOT INSTALLED PERPENDICULAR TO FLOW LINE (RUNOFF ESCAPING AROUND ONE SIDE).

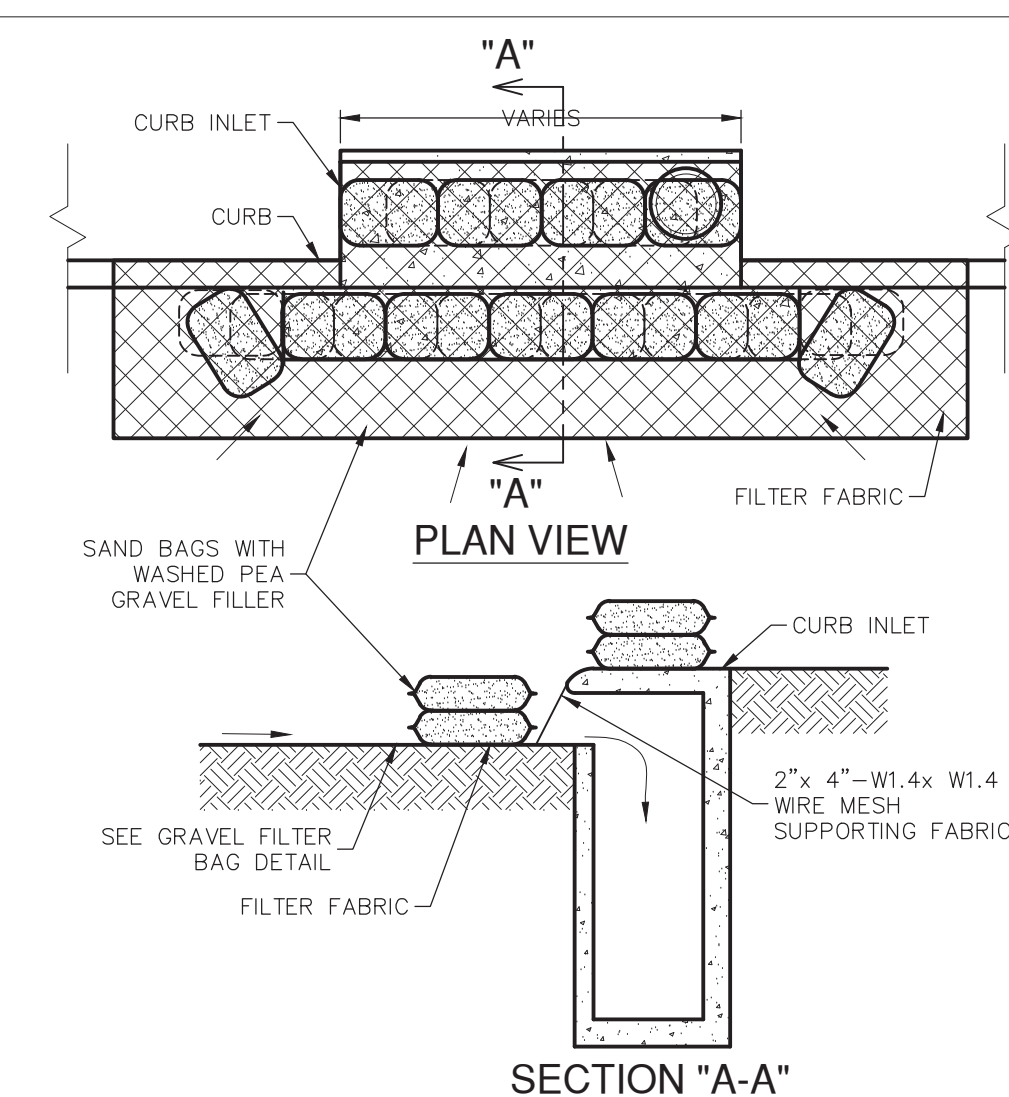

GENERAL NOTES

1. CONTRACTOR TO INSTALL 2"x4"-W1.4xW1.4 WIRE MESH SUPPORTING FILTER FABRIC OVER THE INLET OPENING. FABRIC MUST BE SECURED TO WIRE BACKING WITH CLIPS OR WIRE TIES AT THIS LOCATION. SAND BAGS FILLED WITH WASHED PEA GRAVEL SHOULD BE PLACED ON TOP OF WIRE MESH ON TOP OF THE INLET AS SHOWN ON THIS DETAIL TO HOLD WIRE MESH IN PLACE. SANDBAGS FILLED WITH WASHED PEA GRAVEL SHOULD ALSO BE PLACED ALONG THE GUTTER AS SHOWN ON THIS DETAIL TO HOLD WIRE MESH IN PLACE. SAND BAGS TO BE STACKED TO FORM A CONTINUOUS BARRIER AROUND INLETS.
2. THE BAGS SHOULD BE TIGHTLY BUTTED AGAINST EACH OTHER TO PREVENT RUNOFF FROM FLOWING BETWEEN THE BAGS.
3. CHECK PLACEMENT OF DEVICE TO PREVENT GAPS BETWEEN DEVICE AND CURB.
4. INSPECT FILTER FABRIC AND PATCH OR REPLACE IF TORN OR MISSING.
5. STRUCTURES SHOULD BE REMOVED AND THE AREA STABILIZED ONLY AFTER THE REMAINING DRAINAGE AREA HAS BEEN PROPERLY STABILIZED.

BAGGED GRAVEL CURB INLET PROTECTION DETAIL

NOT-TO-SCALE

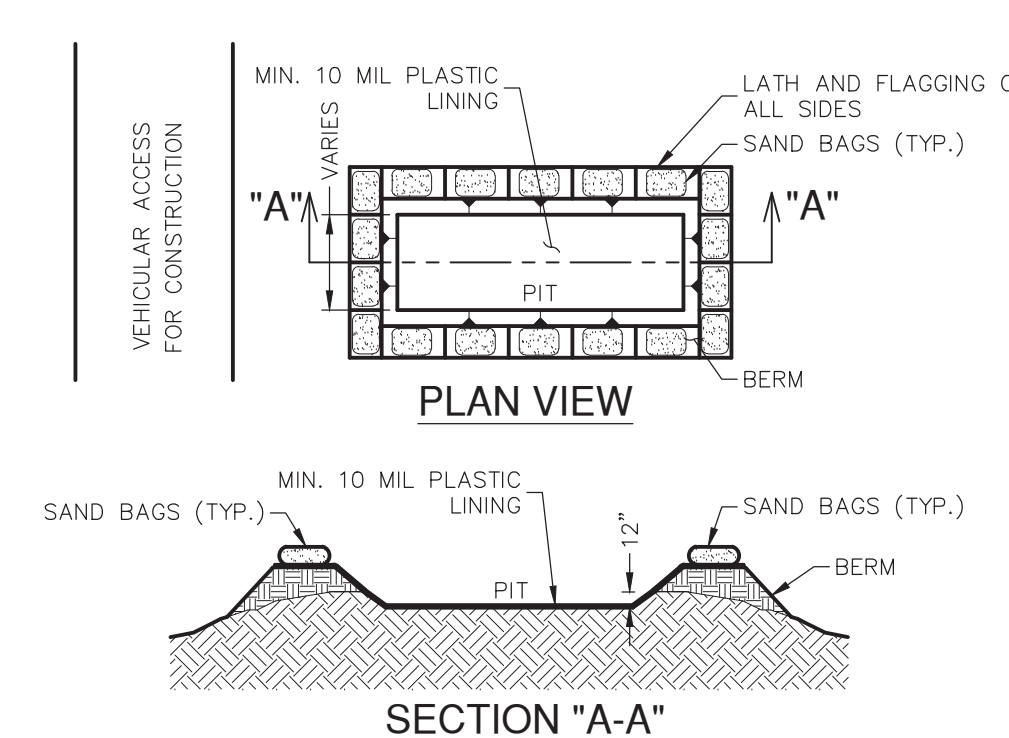

GENERAL NOTES

1. DETAIL ABOVE ILLUSTRATES MINIMUM DIMENSIONS. PIT CAN BE INCREASED IN SIZE DEPENDING ON EXPECTED FREQUENCY OF USE.
2. WASHOUT PIT SHALL BE LOCATED IN AN AREA EASILY ACCESSIBLE TO CONSTRUCTION TRAFFIC.
3. WASHOUT PIT SHALL NOT BE LOCATED IN AREAS SUBJECT TO INUNDATION FROM STORM WATER RUNOFF.
4. LOCATE WASHOUT AREA AT LEAST 50 FEET FROM SENSITIVE FEATURES, STORM DRAINS, OPEN DITCHES OR WATER BODIES.
5. TEMPORARY CONCRETE WASHOUT FACILITY SHOULD BE CONSTRUCTED WITH SUFFICIENT QUANTITY AND VOLUME TO CONTAIN ALL LIQUID AND CONCRETE WASTE GENERATED BY WASHOUT OPERATIONS.

MATERIALS

PLASTIC LINING MATERIAL SHOULD BE A MINIMUM OF 10 MIL IN POLYETHYLENE SHEETING AND SHOULD BE FREE OF HOLES, TEARS, OR OTHER DEFECTS THAT COMPROMISE THE IMPERMEABILITY OF THE MATERIAL.

MAINTENANCE

1. WHEN TEMPORARY CONCRETE WASHOUT FACILITIES ARE NO LONGER REQUIRED FOR THE WORK, THE HARDENED CONCRETE SHOULD BE REMOVED AND DISPOSED OF.
2. MATERIALS USED TO CONSTRUCT TEMPORARY CONCRETE WASHOUT FACILITIES SHOULD BE REMOVED FROM THE SITE OF THE WORK AND DISPOSED OF.
3. HOLES, DEPRESSIONS OR OTHER GROUND DISTURBANCES CAUSED BY THE REMOVAL OF THE TEMPORARY CONCRETE WASHOUT FACILITIES SHOULD BE BACKFILLED AND REPAIRED.

CONCRETE TRUCK WASHOUT PIT DETAIL

NOT-TO-SCALE

THE ENGINEERING SEAL HAS BEEN AFFIXED TO THIS SHEET ONLY FOR THE PURPOSE OF DEMONSTRATING COMPLIANCE WITH THE POLLUTION ABATEMENT SIZING AND TREATMENT REQUIREMENTS OF THE TEXAS COMMISSION ON ENVIRONMENTAL QUALITY'S EDWARDS AQUIFER TECHNICAL GUIDANCE MANUAL.

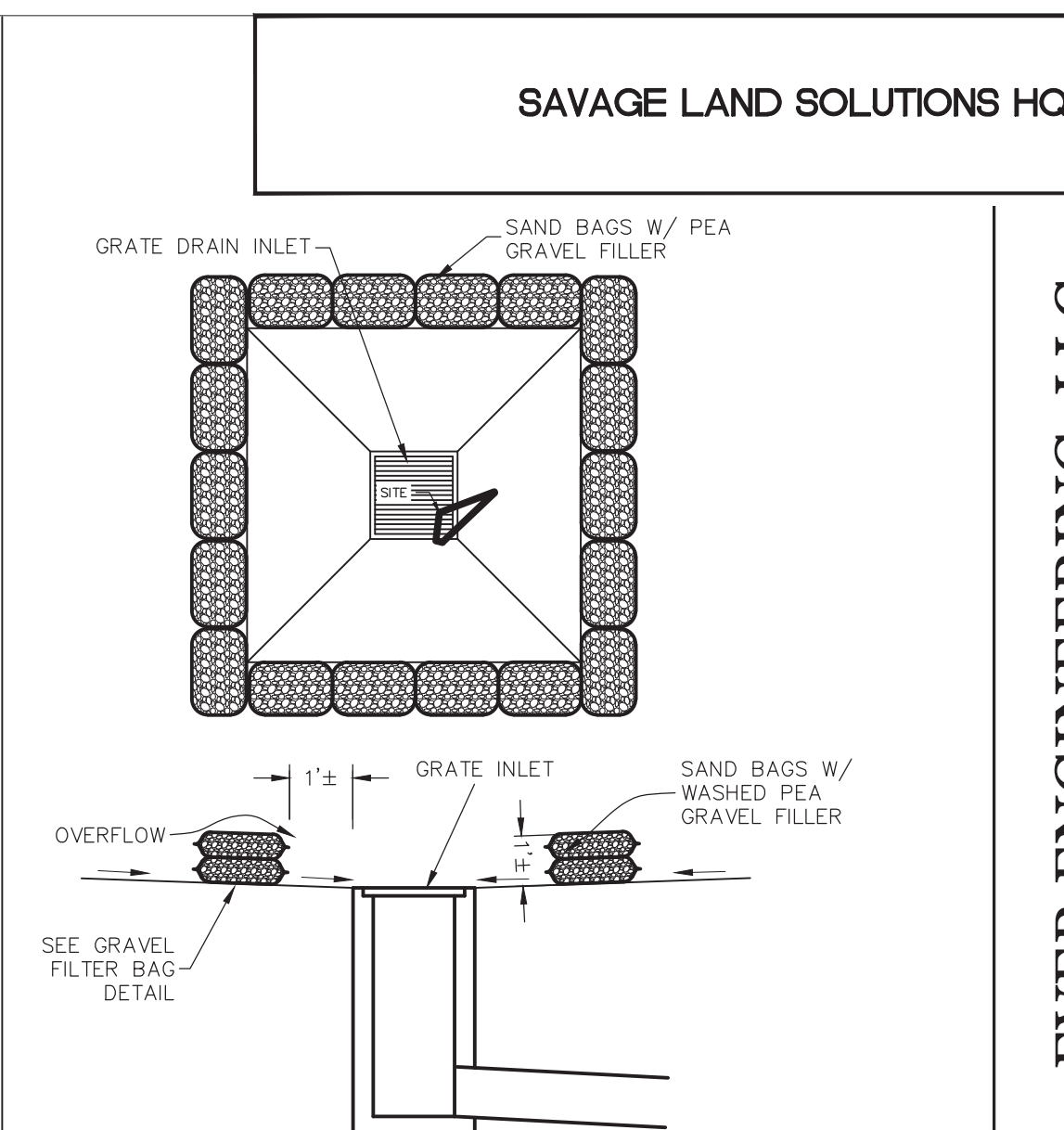

GENERAL NOTES

- 1) THE SANDBAGS SHOULD BE FILLED WITH WASHED PEA GRAVEL AND STACKED TO FORM A CONTINUOUS BARRIER ABOUT 1 FOOT HIGH AROUND INLETS.
- 2) THE BAGS SHOULD BE TIGHTLY BUTTED AGAINST EACH OTHER TO PREVENT RUNOFF FROM FLOWING BETWEEN THE BAGS.
- 3) CHECK PLACEMENT OF DEVICE TO PREVENT GAPS BETWEEN DEVICE AND CURB.
- 4) INSPECT FILTER FABRIC AND PATCH OR REPLACE IF TORN OR MISSING.
- 5) STRUCTURES SHOULD BE REMOVED AND THE AREA STABILIZED ONLY AFTER THE REMAINING DRAINAGE AREA HAS BEEN PROPERLY STABILIZED.

BAGGED GRAVEL GRATE INLET PROTECTION

NOT-TO-SCALE

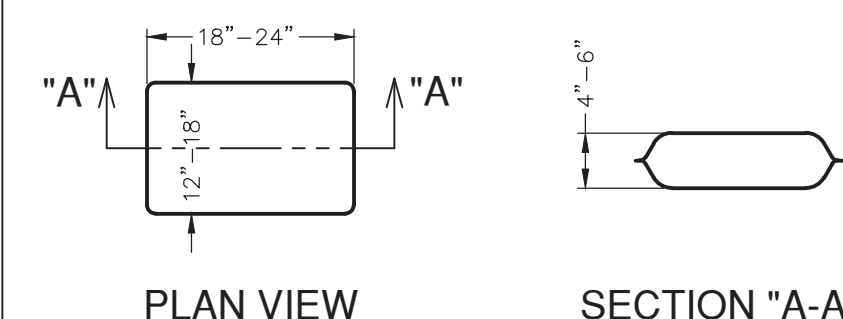

PLAN VIEW

SECTION 'A-A'

- NOTES:
1. THE FILTER BAG MATERIAL SHALL BE MADE OF POLYPROPYLENE, POLYETHYLENE OR POLYAMIDE WOVEN FABRIC, MIN. UNIT WEIGHT OF 4 OUNCES/SY, HAVE A MULLEN BURST STRENGTH EXCEEDING 300 PSI AND ULTRAVIOLET STABILITY EXCEEDING 70%.
 2. THE FILTER BAG SHALL BE FILLED WITH CLEAN, MEDIUM WASHED PEA GRAVEL TO COARSE GRAVEL (0.31 TO 0.75 INCH DIAMETER).
 3. SAND SHALL NOT BE USED TO FILL THE FILTER BAGS.

GRAVEL FILTER BAG DETAIL

NOT-TO-SCALE

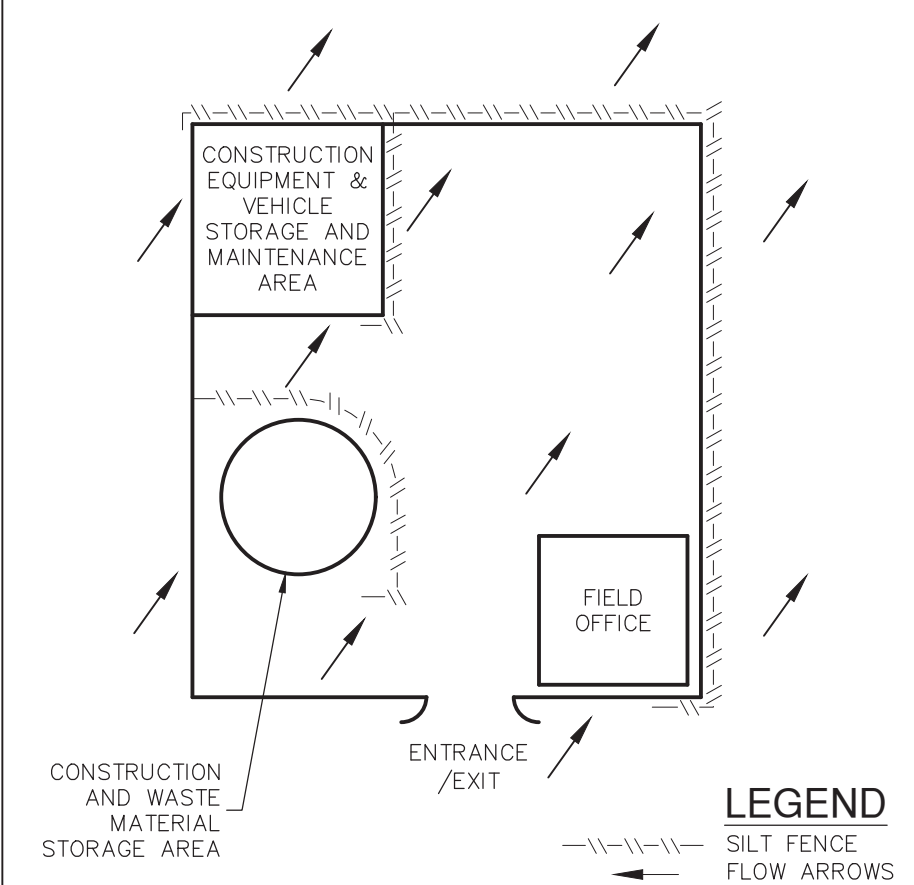

CONSTRUCTION STAGING AREA

NOT-TO-SCALE

THIS SHEET HAS BEEN PREPARED FOR PURPOSES OF POLLUTION ABATEMENT ONLY. ALL OTHER CIVIL ENGINEERING RELATED INFORMATION SHOULD BE ACQUIRED FROM THE APPROPRIATE SHEET IN THE CIVIL IMPROVEMENT PLANS.

EVER ENGINEERING, LLC
ADVANCED ENGINEERING SERVICES

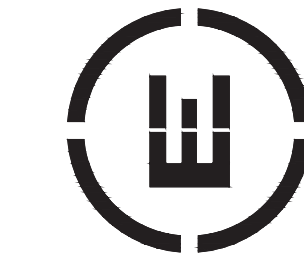

PROJECT LOCATION:
200 FM 321
SAN MARCOS, TEXAS 78666

DATE	REVISIONS

C210 - SWPPP DETAILS - LAYOUT

PLAT NO.:	TBD
DRAWN BY:	CV
CHECKED BY:	ROOM
JOB NO.:	22-0106
DATE:	DEC. 2022

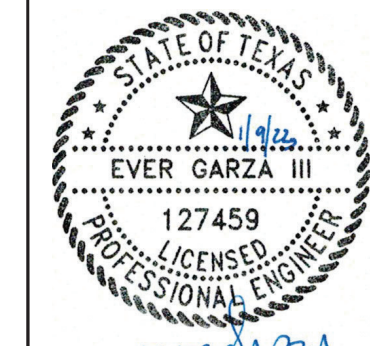

SHEET:

C210

LEGAL DESCRIPTION

1.8558-ACRE TRACT
ABS 25
JAMES ALSTON SURVEY

SAVAGE LAND SOLUTIONS HO

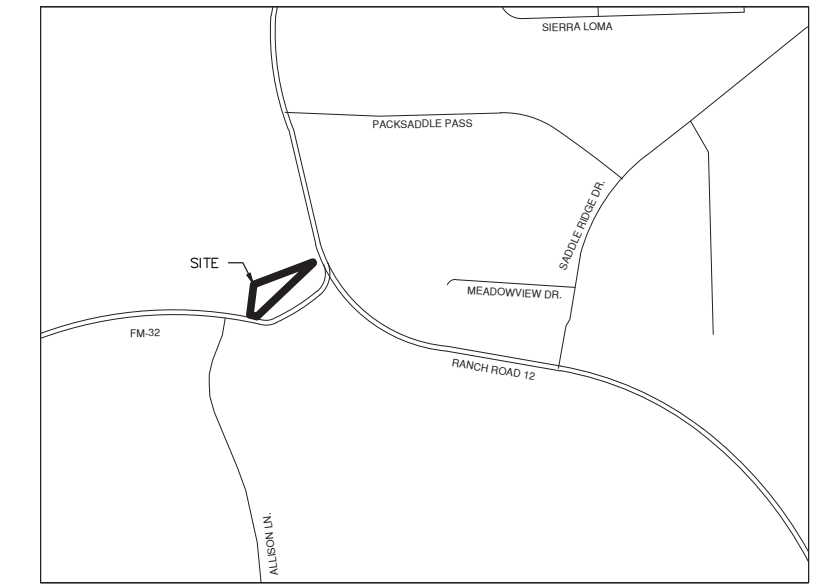

LOCATION MAP
NOT-TO-SCALE

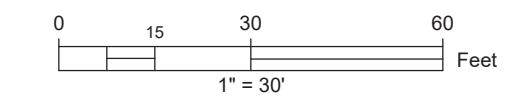
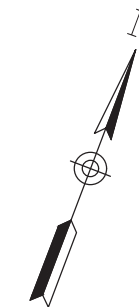

LEGEND

- PROPERTY LINE
- ADJACENT PROPERTY LINE
- FIRE LANE
- HAND PULL HOSE LAY TO TRUCK (MAX 150')

FIRE PROTECTION NOTES:

1. FIRE LANES SHALL HAVE A MINIMUM 2-WAY TRAFFIC WIDTH OF 20 FT. WITH A MINIMUM OUTSIDE TURNING RADIUS OF 50 FT., UNLESS OTHERWISE NOTED.
2. FIRE LANES NEXT TO FIRE HYDRANTS OR DESIGNATED FOR AERIAL APPARATUS SHALL BE A MINIMUM OF 26 FT.
3. FIRE LANES SHALL BE DESIGNATED IN ACCORDANCE TO THE LATEST INTERNATIONAL FIRE CODE AND PER APPLICABLE LOCAL AMENDMENTS.
4. FIRE LANES SHALL BE MARKED BY LINES OF RED TRAFFIC PAINT OR DYE A MINIMUM OF 6 INCHES IN WIDTH TO SHOW THE BOUNDARIES OF THE LANE.
5. FIRE LANES SHALL BE DESIGNED AND MAINTAINED TO SUPPORT IMPOSED LOADS OF FIRE APPARATUS AND SHALL BE SURFACED SO AS TO PROVIDE ALL-WEATHER DRIVING CAPABILITIES.

FIRE LINE NOTE:

ALL FIRE LINES SHALL BE AWWA C-900, CLASS 235 DR-18, UNLESS OTHERWISE NOTED.

51.43 ACRES
"TRACT TWO"
FRED W. FELTNER
DOCUMENT NO. 10018353
H.C.O.P.R.

4.55 ACRES
SUZANE MEBANE
DOCUMENT NO. 366398
H.C.O.P.R.

0.721 ACRES
STATE OF TEXAS
DOCUMENT NO. 90033150
H.C.O.P.R.

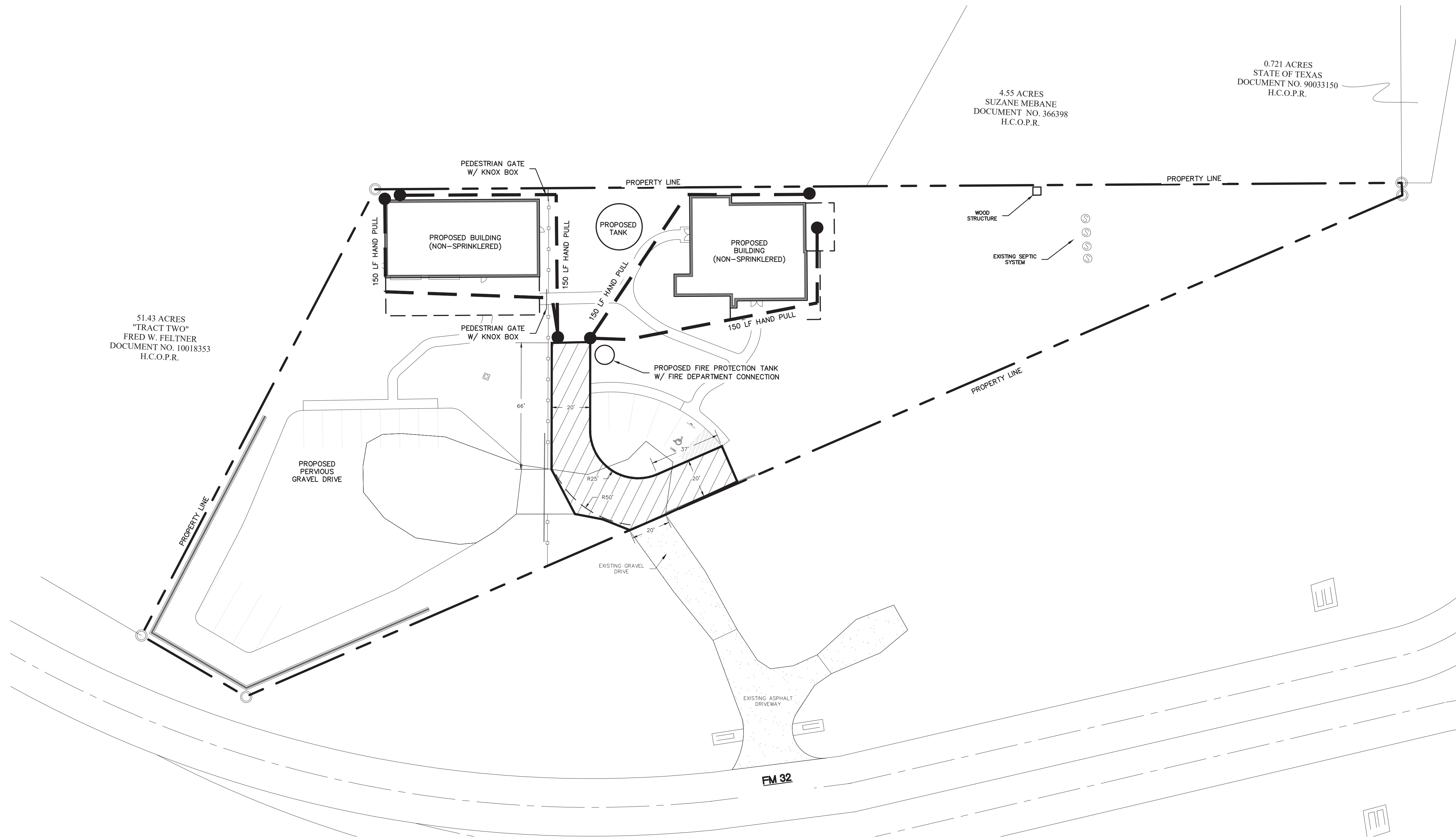

EVER ENGINEERING, LLC
ADVANCED ENGINEERING SERVICES
3201 CHERRY RIDGE DRIVE, SUITE A-106,
SAN ANTONIO, TX 78230
OFFICE (210) 572-9340, FAX (210) 572-9344
WWW.EVERENC.COM, WWW.AES-TX.COM
FORM NO. E-18197



PROJECT LOCATION:
200 FM 32
SAN MARCOS, TEXAS 78666

DATE	REVISIONS

FIRE PROTECTION PLAN

PLAT NO.:	TBD
DRAWN:	GV
CHECKED:	ROM
JOB NO.:	22-0106
DATE:	DEC. 2022



SHEET:
C3.00

LEGAL DESCRIPTION

1.8558-ACRE TRACT
ABS 25
JAMES ALSTON SURVEY

SAVAGE LAND SOLUTIONS HO

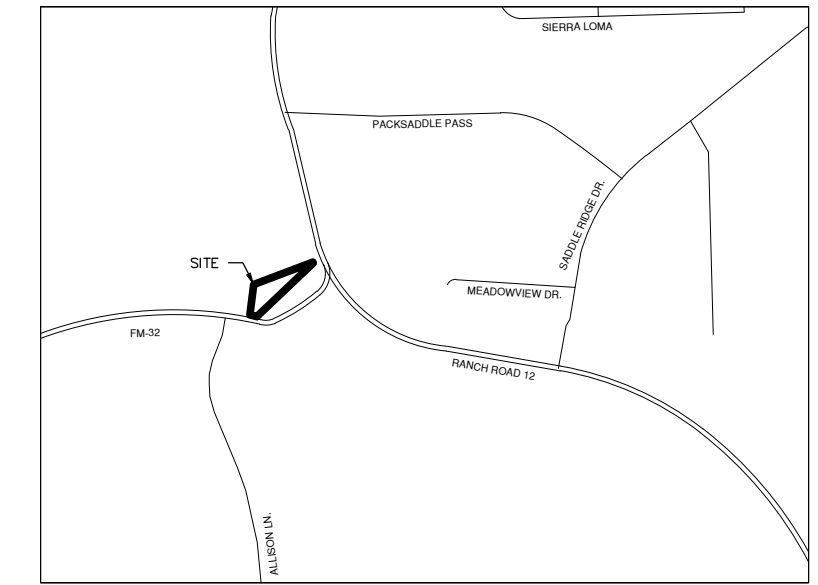

LOCATION MAP
NOT-TO-SCALE

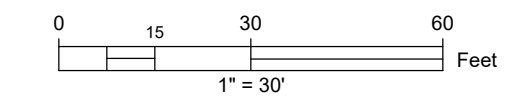
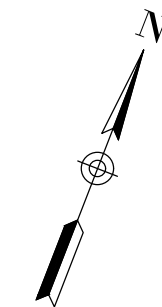

LEGEND

- PROPERTY LINE
- DEMOLITION FEATURE
- TO BE REMOVED
- TREE TO BE REMOVED

DEMOLITION NOTES:

1. THE CONTRACTOR SHALL TAKE ALL PRECAUTIONS NECESSARY TO AVOID DAMAGE TO ADJACENT PROPERTIES DURING THE CONSTRUCTION PHASE OF THE PROJECT. THE CONTRACTOR WILL BE HELD RESPONSIBLE FOR ANY DAMAGES TO ADJACENT PROPERTIES OCCURRING DURING THE CONSTRUCTION PHASE OF THIS PROJECT.
2. THE CONTRACTOR WILL BE RESPONSIBLE FOR PROVIDING AND MAINTAINING TRAFFIC CONTROL DEVICES SUCH AS BARRICADES, WARNING SIGNS, DIRECTIONAL SIGNS, FLAGMEN, AND LIGHTS TO CONTROL THE MOVEMENT OF TRAFFIC WHERE NECESSARY. PLACEMENT OF THESE DEVICES SHALL BE APPROVED BY THE OWNER PRIOR TO PLACEMENT. TRAFFIC CONTROL DEVICES SHALL CONFORM TO THE STANDARDS OF THE APPROPRIATE GOVERNING ENTITIES.
3. IN ACCORDANCE WITH GENERALLY ACCEPTED CONSTRUCTION PRACTICES, THE CONTRACTOR WILL BE SOLELY AND COMPLETELY RESPONSIBLE FOR CONDITIONS ON THE JOB SITE, INCLUDING SAFETY OF ALL PERSONS AND PROPERTY DURING THE PERFORMANCE OF THE WORK. THIS REQUIREMENT WILL APPLY CONTINUOUSLY AND NOT BE LIMITED TO NORMAL WORKING HOURS.
4. THE DUTY OF THE DEVELOPER OR ENGINEER TO CONDUCT CONSTRUCTION REVIEW OF THE CONTRACTOR'S PERFORMANCE IS NOT INTENDED TO REVIEW THE ADEQUACY OF THE CONTRACTOR'S SAFETY MEASURES IN, OR NEAR THE CONSTRUCTION SITE.
5. BEFORE BEGINNING CONSTRUCTION, THE CONTRACTOR SHALL COMPLY WITH THE EROSION CONTROL PLAN AND/OR PERMIT.
6. THE CONTRACTOR SHALL FIELD VERIFY LOCATIONS AND ELEVATIONS OF EXISTING UTILITIES AND TOPOGRAPHIC FEATURES PRIOR TO COMMENCEMENT OF CONSTRUCTION ACTIVITY. THE CONTRACTOR SHALL NOTIFY THE ENGINEER OF ANY DISCREPANCIES OR VARIATIONS FROM THE PLANS.
7. EXISTING TO REMAIN: EXISTING ITEMS OF CONSTRUCTION THAT ARE NOT TO BE PERMANENTLY REMOVED AND THAT ARE NOT OTHERWISE INDICATED TO BE REMOVED, REMOVED AND SALVAGED, OR REMOVED AND REINSTALLED.
8. UNLESS OTHERWISE INDICATED, DEMOLITION WASTE BECOMES THE PROPERTY OF THE CONTRACTOR.
9. IF APPROPRIATE, REFER TO THE ENVIRONMENTAL PLANS AND SPECIFICATIONS FOR HAZARDOUS MATERIAL REMEDIATION
10. TEMPORARY FACILITIES: PROVIDE TEMPORARY BARRICADES AND OTHER PROTECTION REQUIRED TO PREVENT INJURY TO PEOPLE AND DAMAGE TO ADJACENT BUILDINGS AND FACILITIES TO REMAIN.
11. PROVIDE PROTECTION TO ALLOW SAFE PASSAGE OF PEOPLE AROUND SELECTIVE DEMOLITION AREA AND TO AND FROM OCCUPIED PORTIONS OF BUILDING.
12. TEMPORARY SHORING: PROVIDE AND MAINTAIN SHORING, BRACING, AND STRUCTURAL SUPPORTS AS REQUIRED TO PRESERVE STABILITY AND PREVENT MOVEMENT, SETTLEMENT, OR COLLAPSE OF CONSTRUCTION AND FINISHES TO REMAIN, AND TO PREVENT UNEXPECTED OR UNCONTROLLED MOVEMENT OR COLLAPSE OF CONSTRUCTION BEING DEMOLISHED.
13. DEMOLISH AND REMOVE EXISTING CONSTRUCTION ONLY TO THE EXTENT REQUIRED BY NEW CONSTRUCTION AND AS INDICATED. USE METHODS REQUIRED TO COMPLETE THE WORK WITHIN LIMITATIONS OF GOVERNING REGULATIONS.
14. REMOVE DECAYED, VERMIN-INFESTED, OR OTHERWISE DANGEROUS OR UNSUITABLE MATERIALS AND PROMPTLY DISPOSE OF OFF-SITE.
15. EXCEPT FOR ITEM OR MATERIALS INDICATED TO BE RECYCLED, REUSED, SALVAGED, REINSTALLED, OR OTHERWISE INDICATED TO REMAIN OWNER'S PROPERTY, REMOVE DEMOLISHED MATERIALS FROM PROJECT SITE AND LEGALLY DISPOSE OF THEM IN AN APPROVED LANDFILL.
16. DO NOT ALLOW DEMOLISHED MATERIALS TO ACCUMULATE ON-SITE.

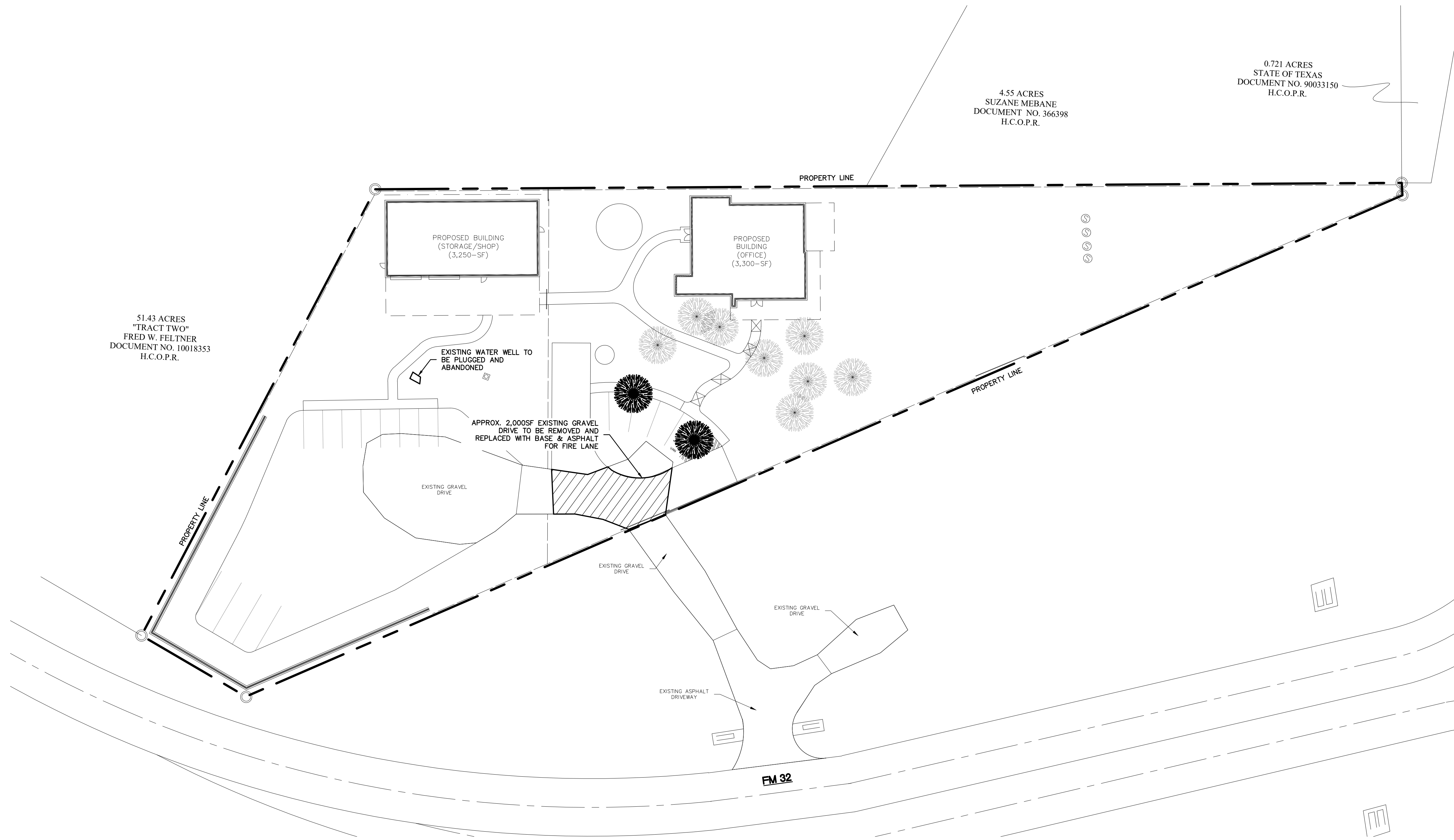

EVER ENGINEERING, LLC
ADVANCED ENGINEERING SERVICES
3201 CHERRY RIDGE DRIVE, SUITE A-106,
SAN ANTONIO, TX 78230
OFFICE (210) 572-9340 • FAX (210) 572-9344
WWW.EVERENG.COM • WWW.AES-TX.COM

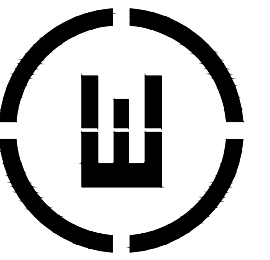

PROJECT LOCATION:
200 FM 32
SAN MARCOS, TEXAS 78666

DEMOLITION PLAN

PLAT NO.: TBD
DRAWN: CV
CHECKED: ROM
JOB NO.: 22-0106
DATE: DEC. 2022

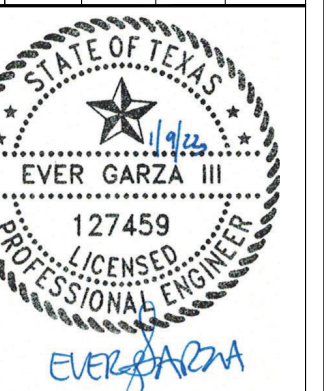

SHEET:
C400

LEGAL DESCRIPTION

1.8558-ACRE TRACT
ABS 25
JAMES ALSTON SURVEY

Curve Table					
Curve #	Length	Radius	Delta	Chord Direction	Chord Length
C1	49.60	25.00	113.66	S77° 49' 18"E	41.85
C2	26.49	73.51	20.65	S69° 32' 30"E	26.35

Point Table		
Point #	Northing	Easting
11	13891326.82	2255376.56
14	13891056.41	2255407.90
16	13891303.37	2255412.08
17	13891406.25	2255694.56
500	13891209.45	2255562.46
501	13891209.83	2255561.88
502	13891209.80	2255547.57
503	13891207.11	2255532.95
504	13891203.07	2255522.60
505	13891224.38	2255513.22
506	13891285.87	2255489.63
507	13891293.04	2255508.31
508	13891273.24	2255515.90
509	13891268.52	2255517.71
510	13891250.74	2255524.53
511	13891241.91	2255565.44
512	13891253.00	2255576.67
513	13891257.24	2255563.35
514	13891276.92	2255566.87

Point Table		
Point #	Northing	Easting
515	13891267.71	2255591.56
516	13891253.49	2255605.62
517	13891224.98	2255576.76
518	13891223.84	2255577.03
600	13891272.01	2255594.12
601	13891280.16	2255575.22
602	13891282.92	2255573.41
603	13891288.88	2255574.06
604	13891293.98	2255576.76
605	13891297.31	2255579.45
606	13891302.00	2255583.19
607	13891310.33	2255587.07
608	13891316.62	2255588.68
609	13891322.49	2255589.72
610	13891330.82	2255588.80
611	13891336.44	2255586.71
612	13891334.60	2255582.06
613	13891328.97	2255584.12
614	13891322.79	2255584.72

Point Table		
Point #	Northing	Easting
615	13891317.86	2255583.84
616	13891306.63	2255580.04
617	13891302.72	2255577.40
618	13891298.05	2255573.62
619	13891295.76	2255571.76
620	13891289.29	2255568.71
621	13891283.37	2255567.74
622	13891282.29	2255564.99
623	13891277.34	2255564.29
1000	13891286.03	2255396.39
1001	13891323.61	2255381.53
1002	13891353.18	2255456.31
1003	13891315.60	2255471.17
1004	13891331.47	2255540.14
1005	13891383.24	2255528.67
1006	13891401.72	2255586.27
1007	13891354.61	2255605.45
1008	13891289.99	2255517.44
1009	13891354.85	2255500.37

SAVAGE LAND SOLUTIONS HO

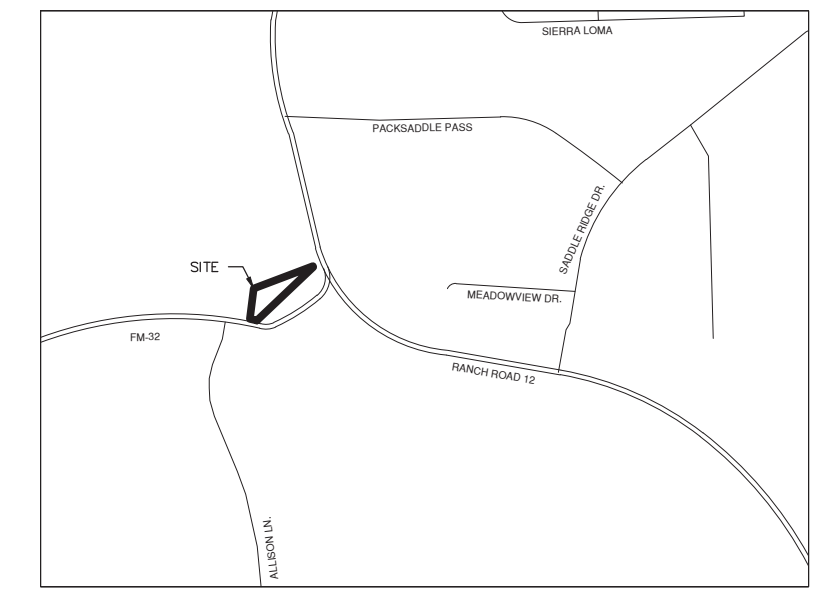

LOCATION MAP
NOT-TO-SCALE

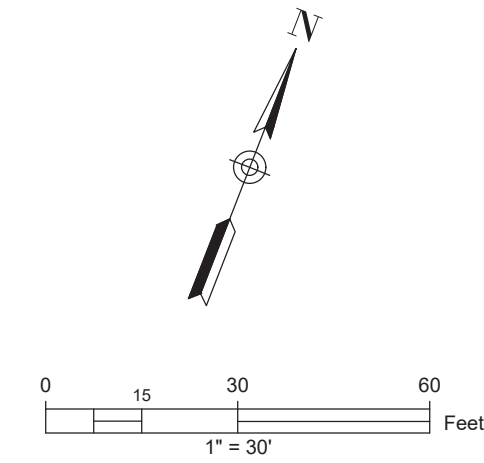

EVER ENGINEERING, LLC
ADVANCED ENGINEERING SERVICES
3201 CHERRY RIDGE DRIVE, SUITE A-106,
SAN ANTONIO, TX 78230
OFFICE (210) 572-9340 FAX (210) 572-9344
WWW.EVERENG.COM WWW.AES-TX.COM
FORM NO. E-1997



LEGEND

PROPERTY LINE	---
PROPOSED PAVING	---
ASPHALT CONTROL POINT	+ 500
SIDEWALK CONTROL POINT	+ 600
STRUCTURE CONTROL POINT	+ 1000

DIMENSIONAL CONTROL NOTES:

- THE CONTRACTOR SHALL IMMEDIATELY NOTIFY THE ENGINEER OF ANY QUESTIONS THAT MAY ARISE CONCERNING THE INTENT, PLACEMENT OR LIMITS OF DIMENSIONS NECESSARY FOR CONSTRUCTION OF THE PROJECT.
- THE CONTRACTOR SHALL PRESERVE ALL CONTROL POINTS, PROPERTY PINS, BENCHMARKS, HUBS OR OTHER KEY CONTROL POINTS. THE CONTRACTOR SHALL BE RESPONSIBLE TO RE-ESTABLISH ANY SUCH POINTS AT THEIR OWN EXPENSE IN THE EVENT THEY ARE REMOVED.
- THE CONTRACTOR SHALL VERIFY ALL DIMENSIONS PRIOR TO THE START OF CONSTRUCTION AND NOTIFY THE ENGINEER OF ANY DISCREPANCIES.
- THE CONTRACTOR SHALL BE RESPONSIBLE FOR ESTABLISHING ALL HORIZONTAL AND VERTICAL CONTROL PER THE CONSTRUCTION DRAWINGS.
- UNLESS OTHERWISE NOTED, THE CONTRACTOR SHALL USE THE PROPERTY PINS FOR HORIZONTAL CONTROL POINTS. BENCHMARKS ARE NOT TO BE USED FOR HORIZONTAL CONTROL.
- COORDINATES FOR HORIZONTAL CONTROL POINTS ARE BASED ON THE TEXAS STATE PLANE COORDINATE SYSTEM, SOUTH CENTRAL ZONE, NAD 83(96) DISPLAYED IN SURFACE VALUES USING A SURFACE ADJUSTMENT FACTOR FOR EACH COUNTY.
- BENCHMARK ELEVATIONS ARE BASED ON TEXAS STATE PLANE COORDINATE SYSTEM SOUTH CENTRAL ZONE NAD 83.
- ALL DIMENSIONAL CONTROL POINTS OR DIMENSIONS ARE TO THE FACE OF CURB, FACE OF RETAINING WALL, AND CENTER OF PAINT STRIPING. ALL DIMENSIONS ARE PERPENDICULAR TO THE POINT OF REFERENCE.
- REFER TO THE ARCHITECTURAL PLANS FOR ADDITIONAL DIMENSIONAL CONTROL INFORMATION.
- CURB RADII ARE 3' UNLESS OTHERWISE NOTED ON THE DRAWINGS.

BENCHMARK:

NO.	ELEVATION	DESCRIPTION
11	1101.19	NAIL RPLS 6154
14	1095.55	IRC RPLS 6154
16	1099.80	S60D
17	1088.87	S60D

COSM SUPPLEMENTAL DEVELOPMENT STANDARDS (SEC. 7.1.2.1)

CATEGORY	PERMITTED USE	MIN. VEHICLE SPACES	MAX. VEHICLE SPACES
COMMERCIAL	OFFICE	1 PER 300 SF GFA	N/A
INDUSTRIAL	WAREHOUSE	1 PER 2,000 SF GFA	N/A

VEHICLE PARKING TOTALS:

WAREHOUSE (SF) = 3,250 SF
OFFICE (SF) = 3,300 SF

MIN REQ. VEHICLE SPACES (VS) = 13 VS
PROVIDED VEHICLE SPACES (VS) = 19 VS

ADA PARKING REQUIREMENTS:

MIN REQ. ADA PARKING SPACES (VS) = 1
MIN REQ. ADA VAN PARKING SPACES (VS) = 1

PROVIDED ADA PARKING SPACES (VS) = 1
PROVIDED ADA VAN PARKING SPACES (VS) = 1

PROJECT LOCATION:
200 FM 32
SAN MARCOS, TEXAS 78666

DATE: _____
REVISIONS:

DIMENSIONAL CONTROL PLAN

PLAT NO.: TBD
DRAWN: CV

CHECKED: ROM

JOB NO.: 22-0106

DATE: DEC. 2022

EVER GARZA III

127459

PROFESSIONAL ENGINEER

EVER GARZA III

SHEET:

C500

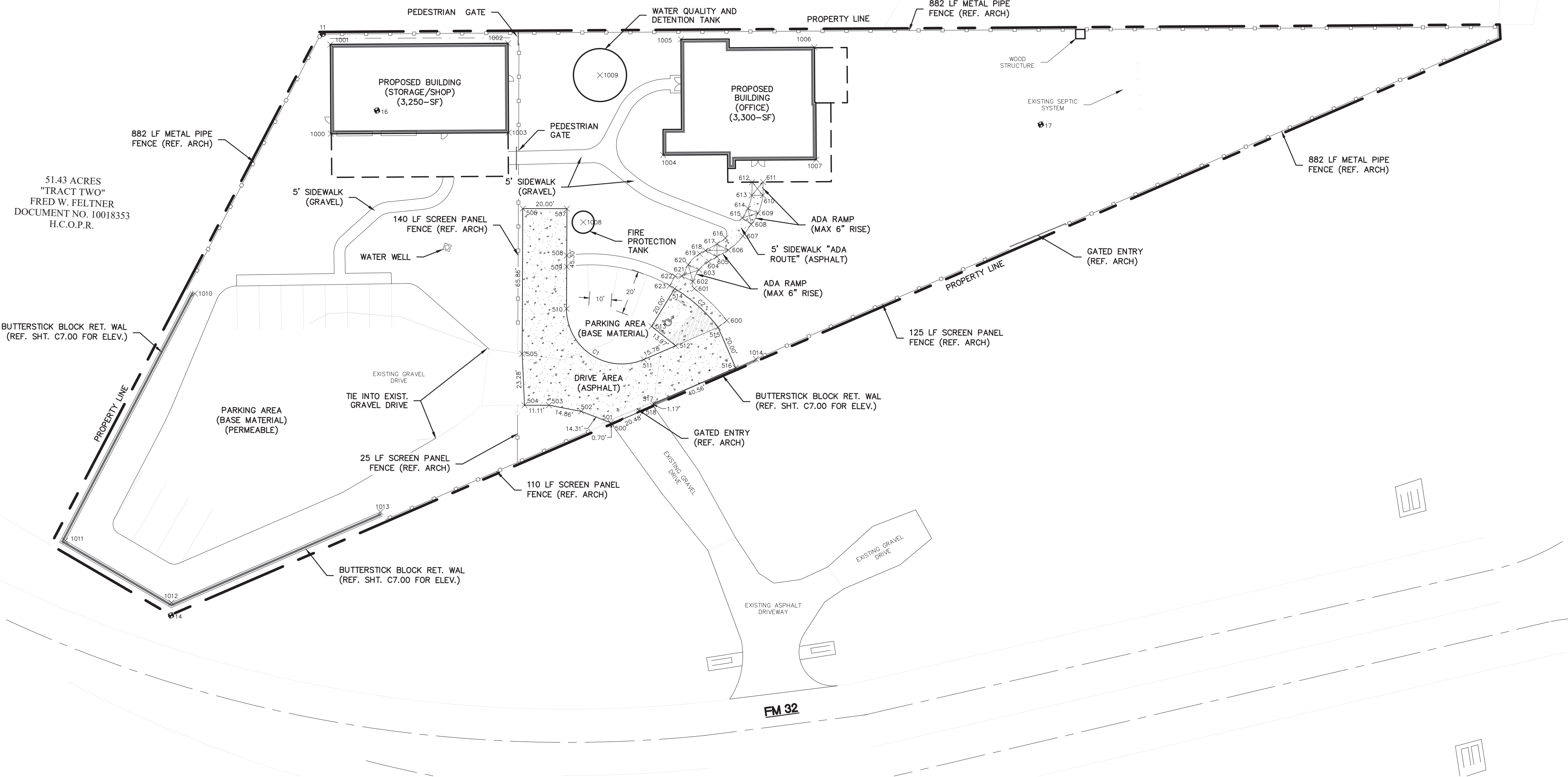

Z:\Projects\2020\0106\05\CONTRACT\C500 - DIM CONTROL PLAN.dwg 12/19/2022 4:57 PM DWG PLOT.PC3

LEGAL DESCRIPTION

1.8558-ACRE TRACT
ABS 25
JAMES ALSTON SURVEY

SAVAGE LAND SOLUTIONS HO

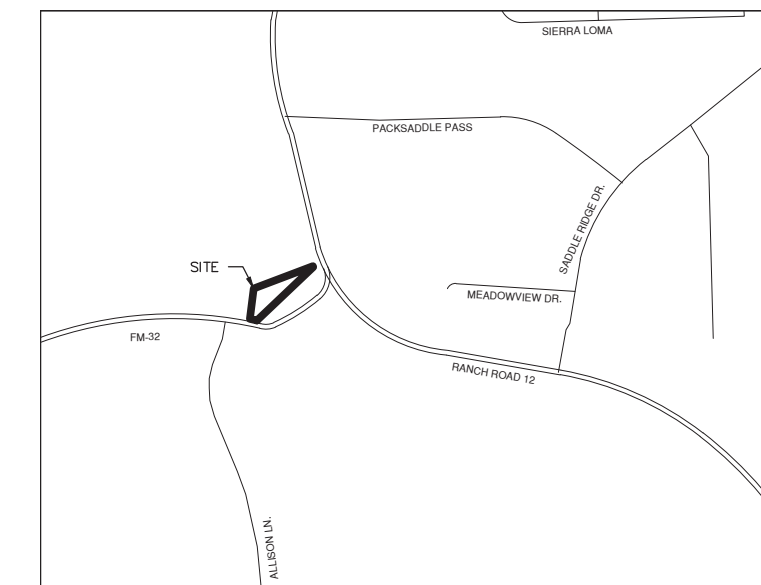

LOCATION MAP
NOT-TO-SCALE

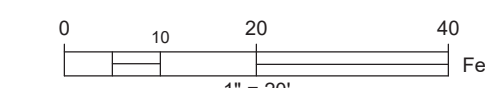
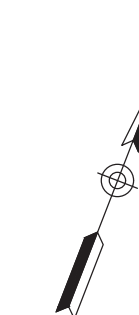

4.55 ACRES
SUZANE MEBANE
DOCUMENT NO. 366398
H.C.O.P.R.

LEGEND

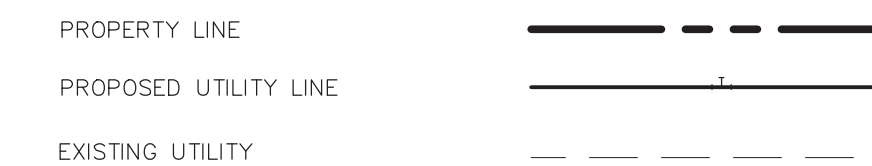

ON-SITE SEWAGE FACILITY (SEPTIC SYSTEM) NOTES:

REFERENCE TCEQ GUIDELINES FOR ON-SITE SEWAGE FACILITIES FOR DESIGN AND INSTALLATION GUIDELINES (ON-SITE SEWAGE FACILITIES, TITLE 30, TAC CHAPTER 285, EFF. 12/29/2016)

TCEQ PROPOSED WATER WELL GENERAL CONSTRUCTION NOTES:

- THESE WATER WELL FACILITIES MUST BE CONSTRUCTED IN ACCORDANCE WITH THE CURRENT TEXAS COMMISSION ON ENVIRONMENTAL QUALITY (TCEQ) RULES AND REGULATIONS FOR PUBLIC WATER SYSTEMS 30 TEXAS ADMINISTRATIVE CODE (TAC) CHAPTER 280 SUBCHAPTER D. WHEN CONFLICTS ARE NOTED WITH LOCAL STANDARDS, THE MORE STRINGENT REQUIREMENT SHALL BE APPLIED. AT A MINIMUM, CONSTRUCTION FOR PUBLIC WATER SYSTEMS MUST ALWAYS MEET TCEQ'S RULES AND REGULATIONS FOR PUBLIC WATER SYSTEMS.
- THE PREMISES, MATERIALS, TOOLS, AND DRILLING EQUIPMENT SHALL BE MAINTAINED SO AS TO MINIMIZE CONTAMINATION OF THE GROUNDWATER DURING DRILLING OPERATION.
- WATER USED IN ANY DRILLING OPERATION SHALL BE OF SAFE SANITARY QUALITY. WATER USED IN THE MIXING OF DRILLING FLUIDS OR MUD SHALL CONTAIN A CHLORINE RESIDUAL OF AT LEAST 0.5 MILLIGRAMS PER LITER (MG/L).
- THE SLUSH PIT SHALL BE CONSTRUCTED AND MAINTAINED SO AS TO MINIMIZE CONTAMINATION OF THE DRILLING MUD.
- NO TEMPORARY TOILET FACILITIES SHALL BE MAINTAINED WITHIN 150 FEET OF THE WELL BEING CONSTRUCTED UNLESS THEY ARE OF A SEALED, LEAKPROOF TYPE.
- THE CONSTRUCTION, DISINFECTION, PROTECTION, AND TESTING OF A WELL TO BE USED AS A PUBLIC WATER SUPPLY SOURCE MUST MEET THE FOLLOWING CONDITIONS.
 - THE CASING MATERIAL USED IN THE CONSTRUCTION OF WELLS FOR PUBLIC USE SHALL BE NEW CARBON STEEL, HIGH STRENGTH LOW ALLOY STEEL, STAINLESS STEEL, OR PLASTIC. THE MATERIAL SHALL CONFORM TO THE MOST RECENT AMERICAN WATER WORKS ASSOCIATION (AWWA) STANDARDS. THE CASING SHALL EXTEND A MINIMUM OF 18 INCHES ABOVE THE ELEVATION OF THE FINISHED FLOOR OF THE PUMP ROOM OR NATURAL GROUND SURFACE AND A MINIMUM OF ONE INCH ABOVE THE SEALING BLOCK OR PUMP MOTOR FOUNDATION BLOCK WHEN PROVIDED. THE CASING SHALL EXTEND AT LEAST TO THE DEPTH OF THE SHALLOWEST WATER FORMATION TO BE DEVELOPED AND DEEPER, IF NECESSARY, IN ORDER TO ELIMINATE ALL UNDESIRABLE WATER BEARING STRATA. WELL CONSTRUCTION MATERIALS CONTAINING MORE THAN 0.25 PERCENT LEAD ARE PROHIBITED.
 - THE SPACE BETWEEN THE CASING AND DRILL HOLE SHALL BE SEALED BY USING ENOUGH CEMENT UNDER PRESSURE TO COMPLETELY FILL AND SEAL THE ANNULAR SPACE BETWEEN THE CASING AND THE DRILL HOLE. THE WELL CASING SHALL BE CEMENTED IN THIS MANNER FROM THE TOP OF THE SHALLOWEST FORMATION TO BE DEVELOPED TO THE EARTH'S SURFACE. THE DRILLER SHALL UTILIZE A PRESSURE CEMENTATION METHOD IN ACCORDANCE WITH THE AWWA STANDARD FOR WATER WELLS (A100-15) OR MOST RECENT, APPENDIX C; SECTION C.2 (POSITIVE DISPLACEMENT EXTERIOR METHOD); SECTION C.3 (INTERIOR METHOD WITHOUT FLOUT); SECTION C.4 (POSITIVE PLACEMENT, INTERIOR METHOD, DRILLABLE PLUG); AND SECTION C.5 (PLACEMENT THROUGH FLOAT SHOE ATTACHED TO BOTTOM OF CASING).
 - THE GROUTING MIXTURE USED TO PRESSURE CEMENT THE ANNULAR SPACE SHALL BE NEAT CEMENT AS SPECIFIED IN THE MOST RECENT AWWA STANDARD FOR WATER WELLS AND TO WHICH A MAXIMUM OF 6% BY DRY WEIGHT, BENTONITE AND 2% BY DRY WEIGHT, CALCIUM CHLORIDE MAY BE ADDED. THE MINIMUM ANNULAR SPACE BETWEEN THE OUTSIDE DIAMETER OF THE CASING PIPE AND THE BOREHOLE SHALL BE NO LESS THAN 1/2 INCHES IN RADIAL THICKNESS OR THREE INCHES IN NET DIAMETRICAL DIFFERENCE AND THE PRESSURE GROUTING SHALL BE FROM THE BOTTOM UPWARD UTILIZING ONE OF THE METHODS LISTED IN THIS SUBPARAGRAPH FOR ALL PUBLIC WATER SYSTEM GROUNDWATER WELL CONSTRUCTION.
 - ALL GRAVEL SHALL BE OF SELECTED AND GRADED QUALITY AND SHALL BE THOROUGHLY DISINFECTED WITH A 50 MG/L CHLORINE SOLUTION AS IT IS ADDED TO THE WELL CAVITY.
 - SAFEGUARDS SHALL BE TAKEN TO PREVENT POSSIBLE CONTAMINATION OF THE WATER OR DAMAGE BY TRESPASSERS FOLLOWING THE COMPLETION OF THE WELL AND PRIOR TO INSTALLATION OF PERMANENT PUMPING EQUIPMENT. UPON WELL COMPLETION, OR AFTER AN EXISTING WELL HAS BEEN REWORKED, THE WELL SHALL BE DISINFECTED IN ACCORDANCE WITH RECENT AWWA STANDARD C654-13 OR MOST RECENT FOR WELL DISINFECTION EXCEPT THAT THE DISINFECTANT SHALL REMAIN IN THE WELL FOR AT LEAST 12-HOURS.
- DECHLORINATION OF DISINFECTING WATER SHALL BE IN STRICT ACCORDANCE WITH CURRENT AWWA STANDARD C655-09 OR MOST RECENT.
- THE WELL SITE SHALL BE FINE GRADED SO THAT THE SITE IS FREE FROM DEPRESSIONS, REVERSE GRADES, OR AREAS TOO ROUGH FOR PROPER GROUND MAINTENANCE SO AS TO ENSURE THAT SURFACE WATER WILL DRAIN AWAY FROM THE WELL. IN ALL CASES, ARRANGEMENTS SHALL BE MADE TO CONVEY WELL PUMP DRAINAGE, PACKING GLAND LEAKAGE, AND FLOOR DRAINAGE AWAY FROM THE WELLHEAD. SUITABLE DRAIN PIPES LOCATED AT THE OUTER EDGE OF THE CONCRETE FLOOR SHALL BE PROVIDED TO COLLECT THIS WATER AND PREVENT ITS PONDING OR COLLECTING AROUND THE WELLHEAD. THIS WASTEWATER SHALL BE DISPOSED OF IN A MANNER THAT WILL NOT CAUSE ANY NUISANCE FROM MOSQUITO BREEDING OR STAGNATION. DRAINS SHALL NOT BE DIRECTLY CONNECTED TO STORM OR SANITARY SEWERS.
- A CONCRETE SEALING BLOCK EXTENDING AT LEAST THREE FEET FROM THE WELL CASING IN ALL DIRECTIONS, WITH A MINIMUM THICKNESS OF SIX INCHES AND SLOPED TO DRAIN AWAY AT NOT LESS THAN 0.25 INCHES PER FOOT SHALL BE PROVIDED AROUND THE WELLHEAD.
- WELLHEADS AND PUMP BASES SHALL BE SEALED BY A GASKET OR SEALING COMPOUND AND PROPERLY VENTED TO PREVENT THE POSSIBILITY OF CONTAMINATING THE WELL WATER. A WELL CASING VENT SHALL BE PROVIDED WITH AN OPENING THAT IS COVERED WITH 16-MESH OR FINER CORROSION RESISTANT SCREEN, FACING DOWNWARD, ELEVATED AND LOCATED SO AS TO MINIMIZE THE DRAWING OF CONTAMINANTS INTO THE WELL. WELLHEADS AND WELL VENTS SHALL BE AT LEAST TWO FEET ABOVE THE HIGHEST KNOWN WATERMARK OR 100 YEAR FLOOD ELEVATION, IF AVAILABLE OR ADEQUATELY PROTECTED FROM POSSIBLE FLOOD DAMAGE BY LEVEES.
- IF A WELL BLOW OFF LINE IS PROVIDED, ITS DISCHARGE SHALL TERMINATE IN A DOWNWARD DIRECTION AND AT A POINT WHICH WILL NOT BE SUBMERGED BY FLOOD WATERS.
- A SUITABLE SAMPLING COCK SHALL BE PROVIDED ON THE DISCHARGE PIPE OF EACH WELL PUMP PRIOR TO ANY TREATMENT.
- FLOW MEASURING DEVICES SHALL BE PROVIDED FOR EACH WELL TO MEASURE PRODUCTION YIELDS AND PROVIDE FOR THE ACCUMULATION OF WATER PRODUCTION DATA. THESE DEVICES SHALL BE LOCATED TO FACILITATE DAILY READING.
- ALL COMPLETED WELL UNITS SHALL BE PROTECTED BY INTRUDER RESISTANT FENCES, THE GATES OF WHICH ARE PROVIDED WITH LOCKS OR SHALL BE ENCLOSED IN LOCKED, VENTILATED WELL HOUSES TO EXCLUDE POSSIBLE CONTAMINATION OR DAMAGE TO THE FACILITIES BY TRESPASSERS. THE GATES OR WELL HOUSES SHALL BE LOCKED DURING PERIODS OF DARKNESS AND WHEN THE PLANT IS UNATTENDED.
- AN ALL-WEATHER ACCESS SHALL BE PROVIDED TO EACH WELL SITE.
- AN AIR RELEASE DEVICE SHALL BE INSTALLED IN SUCH A MANNER AS TO PRECLUDE THE POSSIBILITY OF SUBMERGENCE OR POSSIBLE ENTRANCE OF CONTAMINANTS. IN THIS RESPECT, ALL OPENINGS TO THE ATMOSPHERE SHALL BE COVERED WITH 16-MESH OR FINER, CORROSION RESISTANT SCREENING MATERIAL OR AN ACCEPTABLE EQUIVALENT.

EXISTING UTILITY NOTE:

LOCATIONS AND DEPTH OF EXISTING UTILITIES AND SERVICE LATERALS SHOWN ON THE PLANS ARE UNDERSTOOD TO BE APPROXIMATE. ACTUAL LOCATIONS AND DEPTHS MUST BE FIELD VERIFIED BY THE CONTRACTOR AT LEAST 1 WEEK PRIOR TO CONSTRUCTION. IT SHALL BE THE CONTRACTOR'S RESPONSIBILITY TO COORDINATE, VERIFY THE EXACT LOCATION, & IDENTIFY AREA OF CONFLICTS WITH EXISTING UTILITIES. CONTRACTOR SHALL IMMEDIATELY NOTIFY THE ENGINEER IF CONFLICT IS FOUND.

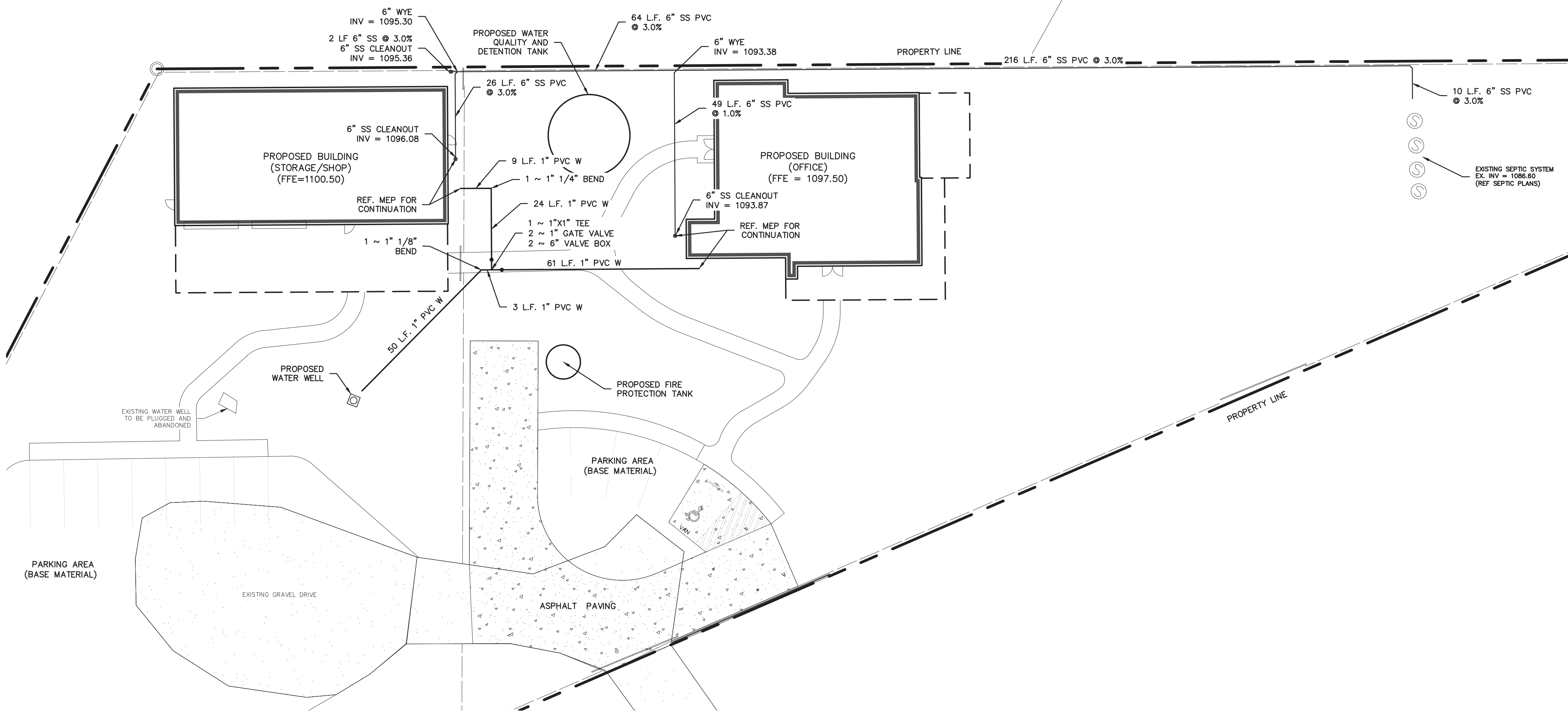

EVER ENGINEERING, LLC
ADVANCED ENGINEERING SERVICES
3201 CHERRY RIDGE DRIVE, SUITE A-106,
SAN ANTONIO, TX 78230
OFFICE (210) 572-9340 FAX (210) 572-9344
WWW.EVERENG.COM, WWW.AES-TX.COM
PHN. NO. 1-1917



PROJECT LOCATION:
200 FM 32
SAN MARCOS, TEXAS 78666

DATE	REVISIONS

UTILITY PLAN

PLAT NO.:	TBD
DRAWN:	CV
CHECKED:	ROM
JOB NO.:	22-0106
DATE:	DEC. 2022

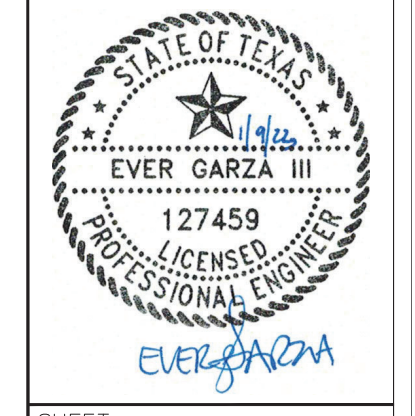

SHEET:
C600

LEGAL DESCRIPTION

1.8558-ACRE TRACT
ABS 25
JAMES ALSTON SURVEY

**TCEQ PROPOSED WATER WELL
GENERAL CONSTRUCTION NOTES:**

- THESE WATER WELL FACILITIES MUST BE CONSTRUCTED IN ACCORDANCE WITH THE CURRENT TEXAS COMMISSION ON ENVIRONMENTAL QUALITY (TCEQ) RULES AND REGULATIONS FOR PUBLIC WATER SYSTEMS 30 TEXAS ADMINISTRATIVE CODE (TAC) CHAPTER 290 SUBCHAPTER D. WHEN CONFLICTS ARE NOTED WITH LOCAL STANDARDS, THE MORE STRINGENT REQUIREMENT SHALL BE APPLIED. AT A MINIMUM, CONSTRUCTION FOR PUBLIC WATER SYSTEMS MUST ALWAYS MEET TCEQ'S "RULES AND REGULATIONS FOR PUBLIC WATER SYSTEMS."
- THE PREMISES, MATERIALS, TOOLS, AND DRILLING EQUIPMENT SHALL BE MAINTAINED SO AS TO MINIMIZE CONTAMINATION OF THE GROUNDWATER DURING DRILLING OPERATION.
- WATER USED IN ANY DRILLING OPERATION SHALL BE OF SAFE SANITARY QUALITY. WATER USED IN THE MIXING OF DRILLING FLUIDS OR MUD SHALL CONTAIN A CHLORINE RESIDUAL OF AT LEAST 0.5 MILLIGRAMS PER LITER (MG/L).
- THE SLUSH PIT SHALL BE CONSTRUCTED AND MAINTAINED SO AS TO MINIMIZE CONTAMINATION OF THE DRILLING MUD.
- NO TEMPORARY TOILET FACILITIES SHALL BE MAINTAINED WITHIN 150 FEET OF THE WELL BEING CONSTRUCTED UNLESS THEY ARE OF A SEALED, LEAKPROOF TYPE.
- THE CONSTRUCTION, DISINFECTION, PROTECTION, AND TESTING OF A WELL TO BE USED AS A PUBLIC WATER SUPPLY SOURCE MUST MEET THE FOLLOWING CONDITIONS.
 - THE CASING MATERIAL USED IN THE CONSTRUCTION OF WELLS FOR PUBLIC USE SHALL BE NEW CARBON STEEL, HIGH STRENGTH LOW ALLOY STEEL, STAINLESS STEEL OR PLASTIC. THE MATERIAL SHALL CONFORM TO THE MOST RECENT AMERICAN WATER WORKS ASSOCIATION (AWWA) STANDARDS. THE CASING SHALL EXTEND A MINIMUM OF 18 INCHES ABOVE THE ELEVATION OF THE FINISHED FLOOR OF THE PUMP ROOM OR NATURAL GROUND SURFACE AND A MINIMUM OF ONE INCH ABOVE THE SEALING BLOCK OR PUMP MOTOR FOUNDATION BLOCK WHEN PROVIDED. THE CASING SHALL EXTEND AT LEAST TO THE DEPTH OF THE SHALLOWEST WATER FORMATION TO BE DEVELOPED AND DEEPER, IF NECESSARY, IN ORDER TO ELIMINATE ALL UNDESIRABLE WATER BEARING STRATA. WELL CONSTRUCTION MATERIALS CONTAINING MORE THAN 0.25 PERCENT LEAD ARE PROHIBITED.
 - THE SPACE BETWEEN THE CASING AND DRILL HOLE SHALL BE SEALED BY USING ENOUGH CEMENT UNDER PRESSURE TO COMPLETELY FILL AND SEAL THE ANNULAR SPACE BETWEEN THE CASING AND THE DRILL HOLE. THE WELL CASING SHALL BE CEMENTED IN THIS MANNER FROM THE TOP OF THE SHALLOWEST FORMATION TO BE DEVELOPED TO THE EARTH'S SURFACE. THE DRILLER SHALL UTILIZE A PRESSURE CEMENTATION METHOD IN ACCORDANCE WITH THE AWWA STANDARD FOR WATER WELLS (A100-15) OR MOST RECENT, APPENDIX C, SECTION C.2 (POSITIVE DISPLACEMENT EXTERIOR METHOD); SECTION C.3 (INTERIOR METHOD WITHOUT PLUG); SECTION C.4 (POSITIVE PLACEMENT, INTERIOR METHOD, DRILLABLE PLUG); AND SECTION C.5 (PLACEMENT THROUGH FLOAT SHOE ATTACHED TO BOTTOM OF CASING).
 - THE GROUTING MIXTURE USED TO PRESSURE CEMENT THE ANNULAR SPACE SHALL BE NEAT CEMENT AS SPECIFIED IN THE MOST RECENT AWWA STANDARD FOR WATER WELLS AND TO WHICH A MAXIMUM OF 6% BY DRY WEIGHT, BENTONITE AND 2% BY DRY WEIGHT, CALCIUM CHLORIDE MAY BE ADDED. THE MINIMUM ANNULAR SPACE BETWEEN THE OUTSIDE DIAMETER OF THE CASING PIPE AND THE BOREHOLE SHALL BE NO LESS THAN 1 1/2 INCHES IN RADIAL THICKNESS OR THREE INCHES IN NET DIAMETRICAL DIFFERENCE AND THE PRESSURE GROUTING SHALL BE FROM THE BOTTOM UPWARD UTILIZING ONE OF THE METHODS LISTED IN THIS SUBPARAGRAPH FOR ALL PUBLIC WATER SYSTEM GROUNDWATER WELL CONSTRUCTION.
 - ALL GRAVEL SHALL BE OF SELECTED AND GRADED QUALITY AND SHALL BE THOROUGHLY DISINFECTED WITH A 50 MG/L CHLORINE SOLUTION AS IT IS ADDED TO THE WELL CAVITY.
 - SAFEGUARDS SHALL BE TAKEN TO PREVENT POSSIBLE CONTAMINATION OF THE WATER OR DAMAGE BY TRESPASSERS FOLLOWING THE COMPLETION OF THE WELL AND PRIOR TO INSTALLATION OF PERMANENT PUMPING EQUIPMENT.
 - UPON WELL COMPLETION, OR AFTER AN EXISTING WELL HAS BEEN REWORKED, THE WELL SHALL BE DISINFECTED IN ACCORDANCE WITH RECENT AWWA STANDARD C654-13 OR MOST RECENT FOR WELL DISINFECTION EXCEPT THAT THE DISINFECTANT SHALL REMAIN IN THE WELL FOR AT LEAST 12-HOURS.
 - DECHLORINATION OF DISINFECTING WATER SHALL BE IN STRICT ACCORDANCE WITH CURRENT AWWA STANDARD C655-19 OR MOST RECENT.
 - THE WELL SITE SHALL BE FINE GRADED SO THAT THE SITE IS FREE FROM DEPRESSIONS, REVERSE GRADES, OR AREAS TOO ROUGH FOR PROPER GROUND MAINTENANCE SO AS TO ENSURE THAT SURFACE WATER WILL DRAIN AWAY FROM THE WELL. IN ALL CASES, ARRANGEMENTS SHALL BE MADE TO CONVEY WELL PUMP DRAINAGE, PACKING GLAND LEAKAGE, AND FLOOR DRAINAGE AWAY FROM THE WELLHEAD. SUITABLE DRAIN PIPES LOCATED AT THE OUTER EDGE OF THE CONCRETE FLOOR SHALL BE PROVIDED TO COLLECT THIS WATER AND PREVENT ITS PONDING OR COLLECTING AROUND THE WELLHEAD. THIS WASTEWATER SHALL BE DISPOSED OF IN A MANNER THAT WILL NOT CAUSE ANY NUISANCE FROM MOSQUITO BREEDING OR STAGNATION. DRAINS SHALL NOT BE DIRECTLY CONNECTED TO STORM OR SANITARY SEWERS.
 - A CONCRETE SEALING BLOCK EXTENDING AT LEAST THREE FEET FROM THE WELL CASING IN ALL DIRECTIONS, WITH A MINIMUM THICKNESS OF SIX INCHES AND SLOPED TO DRAIN AWAY AT NOT LESS THAN 0.25 INCHES PER FOOT SHALL BE PROVIDED AROUND THE WELLHEAD.
 - WELLHEADS AND PUMP BASES SHALL BE SEALED BY A GASKET OR SEALING COMPOUND AND PROPERLY VENTED TO PREVENT THE POSSIBILITY OF CONTAMINATING THE WELL WATER. A WELL CASING VENT SHALL BE PROVIDED WITH AN OPENING THAT IS COVERED WITH 16-MESH OR FINER CORROSION RESISTANT SCREEN, FACING DOWNWARD, AND LOCATED SO AS TO MINIMIZE THE DRAWING OF CONTAMINANTS INTO THE WELL. WELLHEADS AND WELL VENTS SHALL BE AT LEAST TWO FEET ABOVE THE HIGHEST KNOWN WATERMARK OR 100 YEAR FLOOD ELEVATION, IF AVAILABLE OR ADEQUATELY PROTECTED FROM POSSIBLE FLOOD DAMAGE BY LEAKS.
 - IF A WELL BLOW OFF LINE IS PROVIDED, ITS DISCHARGE SHALL TERMINATE IN A DOWNWARD DIRECTION AND AT A POINT WHICH WILL NOT BE SUBMERGED BY FLOOD WATERS.
 - A SUITABLE SAMPLING COCK SHALL BE PROVIDED ON THE DISCHARGE PIPE OF EACH WELL PUMP PRIOR TO ANY TREATMENT.
 - FLOW MEASURING DEVICES SHALL BE PROVIDED FOR EACH WELL TO MEASURE PRODUCTION YIELDS AND PROVIDE FOR THE ACCUMULATION OF WATER PRODUCTION DATA. THESE DEVICES SHALL BE LOCATED TO FACILITATE DAILY READING.
 - ALL COMPLETED WELL UNITS SHALL BE PROTECTED BY INTRUDER RESISTANT FENCES, THE GATES OF WHICH ARE PROVIDED WITH LOCKS OR SHALL BE ENCLOSED IN LOCKED, VENTILATED WELL HOUSES TO EXCLUDE POSSIBLE CONTAMINATION OR DAMAGE TO THE FACILITIES BY TRESPASSERS. THE GATES OR WELL HOUSES SHALL BE LOCKED DURING PERIODS OF DARKNESS AND WHEN THE PLANT IS UNATTENDED.
 - AN ALL-WEATHER ACCESS SHALL BE PROVIDED TO EACH WELL SITE.
 - AN AIR RELEASE DEVICE SHALL BE INSTALLED IN SUCH A MANNER AS TO PRECLUDE THE POSSIBILITY OF SUBMERGENCE OR POSSIBLE ENTRANCE OF CONTAMINANTS. IN THIS RESPECT, ALL OPENINGS TO THE ATMOSPHERE SHALL BE COVERED WITH 16-MESH OR FINER, CORROSION RESISTANT SCREENING MATERIAL OR AN ACCEPTABLE EQUIVALENT.

**ON-SITE SEWAGE FACILITY
(SEPTIC SYSTEM) NOTES:**

REFERENCE TCEQ GUIDELINES FOR ON-SITE SEWAGE FACILITIES FOR DESIGN AND INSTALLATION GUIDELINES (ON-SITE SEWAGE FACILITIES, TITLE 30, TAC CHAPTER 285, EFF. 12/29/2016)

PARTS BREAKDOWN

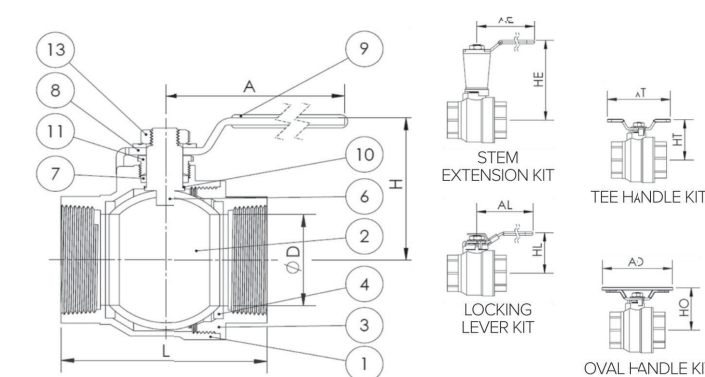

PRESSURE DROP/FLOW OF WATER

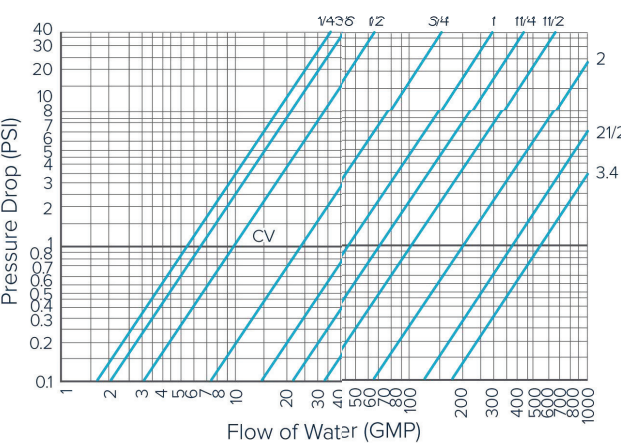

DIMENSIONS (INCHES) & WEIGHT

Size	OD	A	L	H	Wt. (Lb)	AL	HL	AO	HO	AT	HT	AE	HE
1/4	0.35	3.15	1.69	1.42	0.27	3.27	1.65	2.87	1.46	2.60	1.18	2.95	4.29
3/8	0.39	3.15	1.81	1.46	0.30	3.27	1.69	2.87	1.46	2.60	1.38	2.95	4.29
1/2	0.50	3.15	2.13	1.50	0.40	3.27	1.73	2.87	1.50	2.60	1.42	2.95	4.37
3/4	0.75	4.33	2.48	1.85	0.74	4.41	2.13	3.66	1.89	3.31	1.77	3.94	4.72
1	0.99	4.33	2.99	2.05	1.03	4.41	2.32	3.66	2.05	3.31	1.97	3.94	4.92
1 1/4	1.26	5.12	3.35	2.36	1.61	5.24	2.68	4.45	2.40	3.94	2.28	4.92	5.31
1 1/2	1.50	5.12	3.62	2.56	2.11	5.24	2.87	4.45	2.56	3.94	2.48	4.92	5.51
2	1.97	7.87	4.25	3.11	3.83	7.99	3.58	5.47	3.27	4.72	3.11	7.87	6.10
2-1/2	2.48	7.87	5.16	3.50	6.57	7.99	3.98	5.47	3.62	4.72	3.50	7.87	6.50
3	2.95	7.87	5.91	3.86	9.39	7.99	4.33	5.47	3.98	4.72	3.86	7.87	6.81
4	2.95	7.87	6.26	3.86	11.53	7.99	4.33	5.47	3.98	4.72	3.86	7.87	6.81

BALL VALVE DETAIL

(NOT-TO-SCALE)

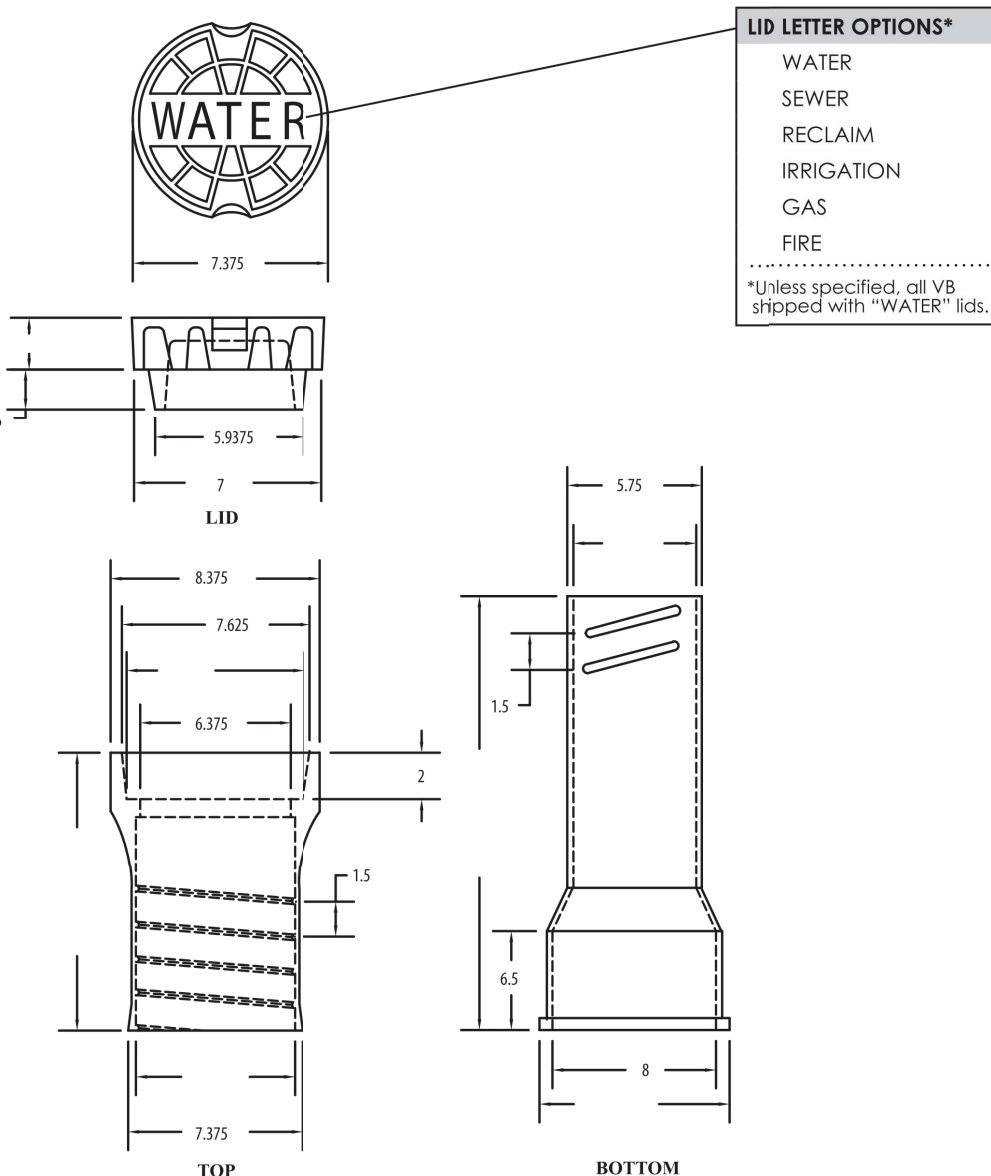

Notes:
- Material - Cast Iron Per ASTM A48 Class 308
- Dimensions in inches

VALVE BOX DETAIL

(NOT-TO-SCALE)

SAVAGE LAND SOLUTIONS HO

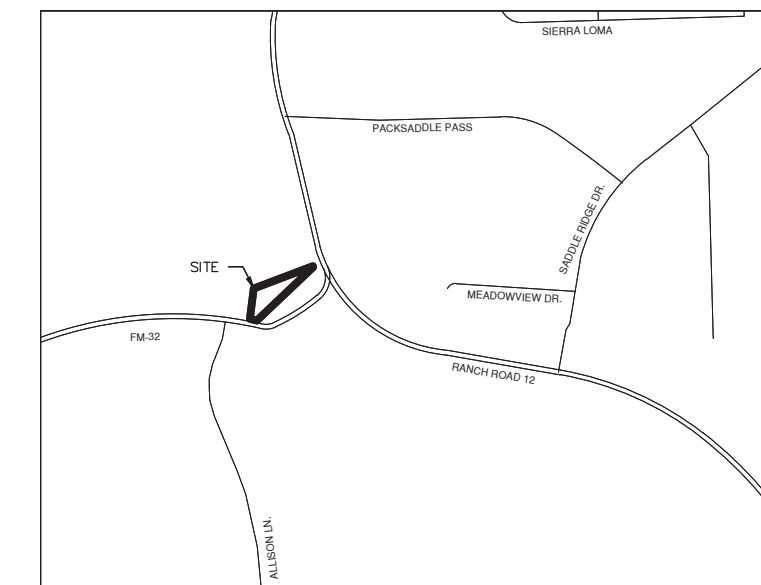

LOCATION MAP
NOT-TO-SCALE

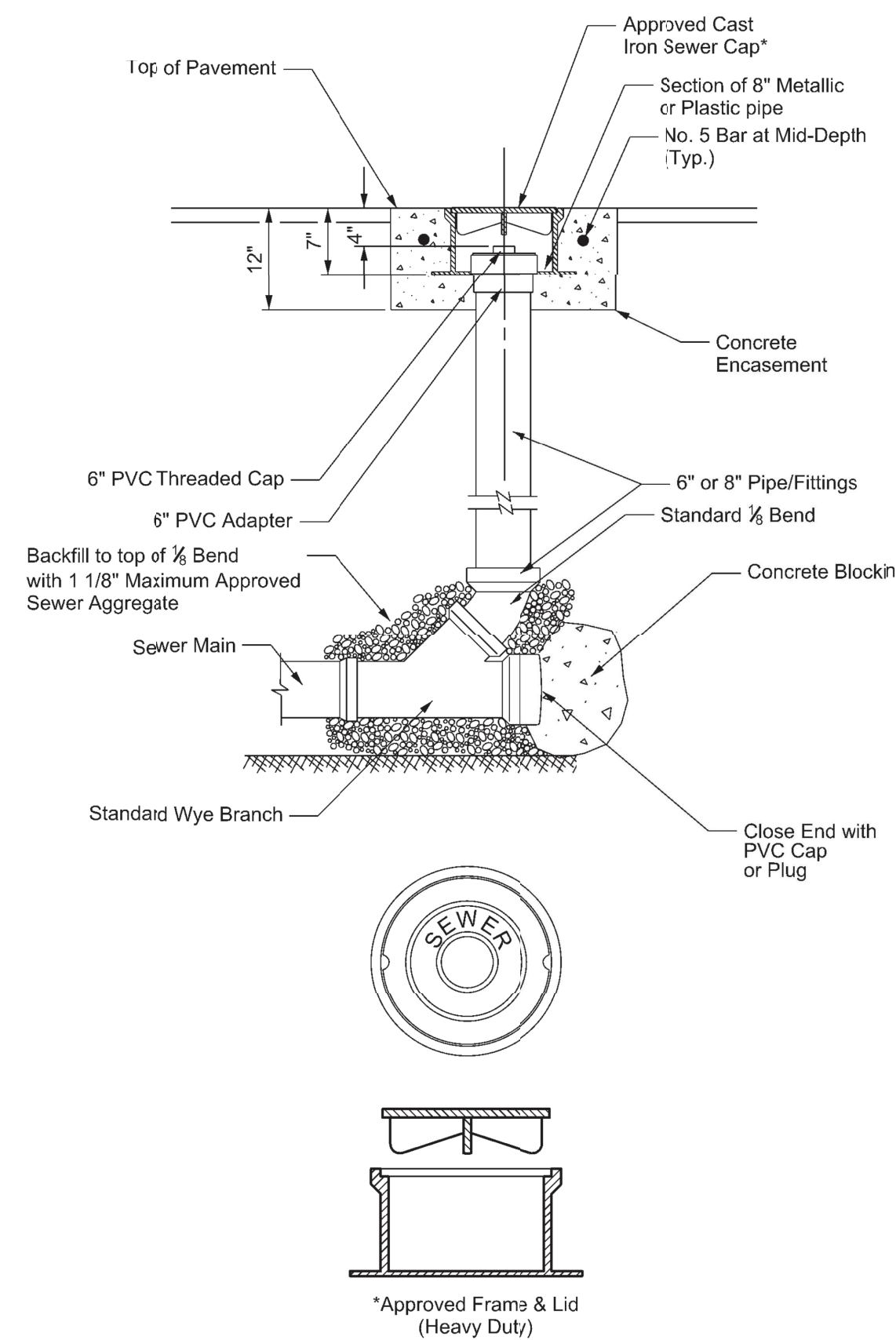

TYPICAL DEAD-END CLEANOUT DETAIL

(NOT-TO-SCALE)

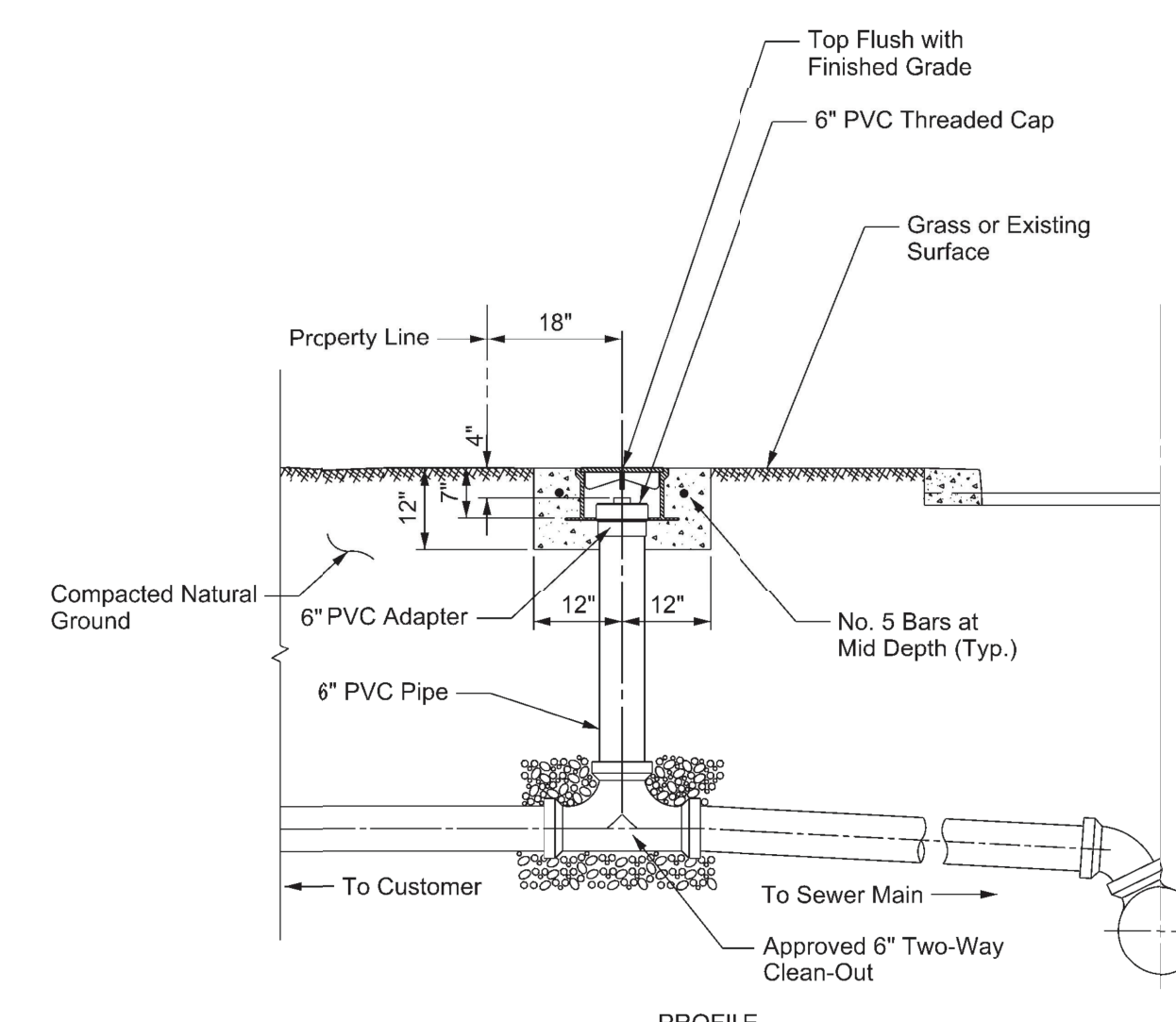

TYPICAL CLEANOUT DETAIL

(NOT-TO-SCALE)

EVER ENGINEERING, LLC
ADVANCED ENGINEERING SERVICES
3201 CHERRY RIDGE DRIVE, SUITE A-106,
SAN ANTONIO, TX 78230
OFFICE (210) 572-9340 FAX (210) 572-9344
WWW.EVERENG.COM, WWW.AES-TX.COM
PH. NO. 1-1917

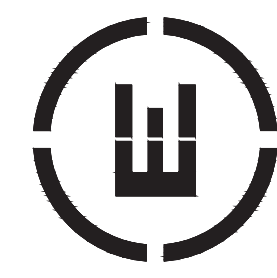

PROJECT LOCATION:
200 FM 32
SAN MARCOS, TEXAS 78666

DATE	REVISIONS

UTILITY DETAILS

PLAT NO.:	TBD
DRAWN:	GV
CHECKED:	ROM
JOB NO.:	22-0106
DATE:	DEC. 2022

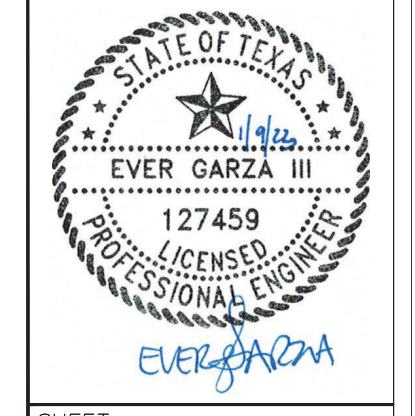

SHEET: **C6.10**

LEGAL DESCRIPTION

1.8558-ACRE TRACT
ABS 25
JAMES ALSTON SURVEY

**** REFERENCE STORM WATER MANAGEMENT PLAN
FOR DETAILED HYDROLOGIC/HYDRAULIC CALCULATIONS
INCLUDING UPSTREAM AND DOWNSTREAM ANALYSIS**

SAVAGE LAND SOLUTIONS HO

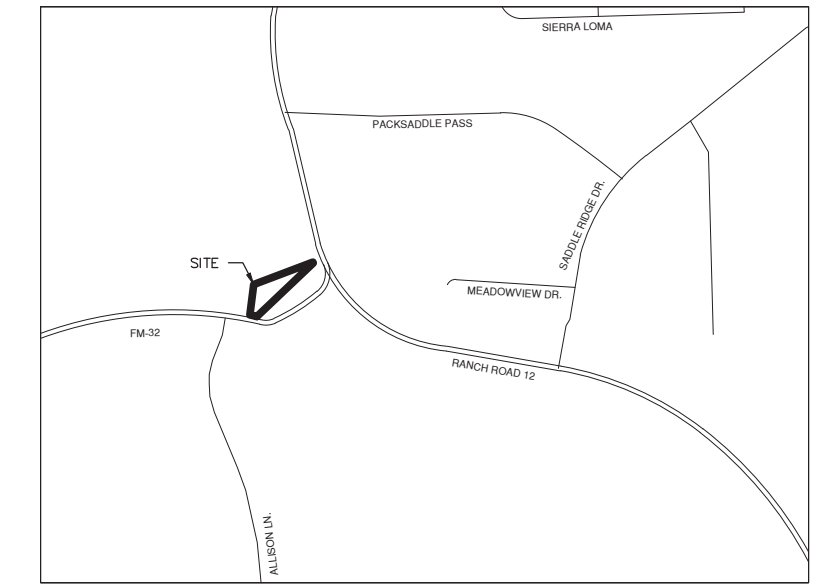

LOCATION MAP
NOT-TO-SCALE

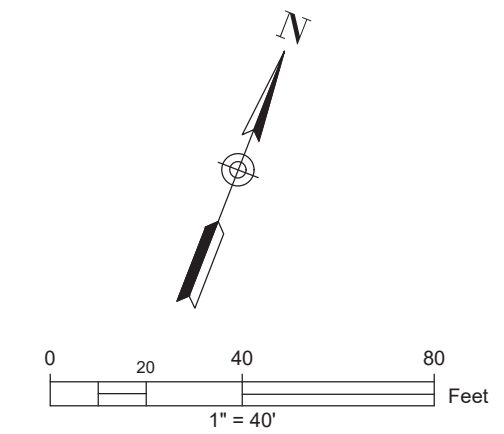

LEGEND

- PROPERTY LINE
- EXISTING CONTOUR
- PROPOSED CONTOUR
- ONSITE WATERSHED
- TC PATH
- FLOW ARROW (EXISTING)
- FLOW ARROW (PROPOSED)

Watershed	Area (ac)	C (unitless)	Tc (min)	Flow (cfs)			
				2	10	25	100
ULTIMATE DEVELOPED							
ONSITE WS-1	3.19	0.60	11	9.32	13.25	16.77	19.62
ROOFTOPS	0.22	0.99	5	1.37	1.99	2.37	2.97
ONSITE WS-1 POST DETENTION	2.97	0.60	11	7.95	11.26	13.40	16.65

** REFERENCE STORMWATER MANAGEMENT PLAN OF SAVAGE LAND SOLUTIONS FOR DRAINAGE CALCULATIONS, ANALYSIS, AND DETAILED PLANS INCLUDING DOWNSTREAM STUDY POINTS **

DRAINAGE NOTES:

1. ALL MATERIALS AND CONSTRUCTION PROCEDURES WITHIN THIS SCOPE OF WORK SHALL COMPLY WITH THE PROJECT GEOTECH REPORT, THE PROJECT SPECIFICATIONS, AND THE CURRENT CITY, COUNTY OR TxDOT STANDARD SPECIFICATIONS FOR PUBLIC WORKS CONSTRUCTION.
2. THE CONTRACTOR SHALL BE REQUIRED TO LOCATE ALL PUBLIC OR PRIVATE UTILITIES INCLUDING BUT NOT LIMITED TO: WATER, SEWER, TELEPHONE, AND FIBER OPTIC LINES, SITE LIGHTING ELECTRIC, SECONDARY ELECTRIC, PRIMARY ELECTRICAL DUCT BANKS, LANDSCAPE IRRIGATION FACILITIES, AND GAS LINES. ANY UTILITY CONFLICTS THAT ARISE SHALL BE COMMUNICATED TO THE ENGINEER IMMEDIATELY AND PRIOR TO CONSTRUCTION. THE CONTRACTOR SHALL CONTACT 1-800-DIG-TESS A MINIMUM OF 48 HOURS PRIOR TO THE START OF CONSTRUCTION. ANY DAMAGE TO EXISTING UTILITIES SHALL BE THE SOLE RESPONSIBILITY OF THE CONTRACTOR AND THE REPAIR SHALL BE AT THE CONTRACTOR'S SOLE EXPENSE WHETHER THE UTILITY IS SHOWN ON THESE PLANS OR NOT.
3. THE CONTRACTOR SHALL PROTECT ALL EXISTING UTILITIES. THE CONTRACTOR SHOULD EXERCISE EXTREME CAUTION WHEN WORKING NEAR EXISTING UTILITIES AND SHOULD THEY BE DAMAGED DURING CONSTRUCTION OPERATIONS, THE CONTRACTOR WILL BE REQUIRED TO REPAIR OR REPLACE THE DAMAGED FACILITIES AT CONTRACTOR'S EXPENSE.
4. THE CONTRACTOR SHALL BE RESPONSIBLE FOR RESTORING TO ORIGINAL OR BETTER CONDITION DAMAGE DONE TO EXISTING FENCES, CURBS, STREETS, DRIVEWAYS, LANDSCAPING AND STRUCTURES.
5. CONTRACTOR IS RESPONSIBLE FOR REMOVAL OF ALL WASTE MATERIALS UPON PROJECT COMPLETION.
6. WATER JETTING THE BACKFILL OF UTILITY TRENCHES WILL NOT BE PERMITTED.
7. NORTHINGS AND EASTINGS LISTED ON THESE PLANS ARE TO CENTER OF BOX FOR JUNCTION BOXES AND GRATE INLETS AND TO OUTSIDE CORNER FACE OF CURB FOR ALL CURBS AND COMBINATION INLETS. ALL LENGTHS OF PIPE ARE TO INSIDE FACE OF STRUCTURES.
8. CONTRACTOR SHALL ENSURE PROPER SIZE OF JUNCTION BOXES NEEDED WHERE INDICATED ON PLAN. CONTRACTOR SHALL CONNECT STORM DRAIN PIPE TO JUNCTION BOXES PER MANUFACTURERS SPECIFICATIONS.
9. ALL STORM DRAIN TO JUNCTION BOX CONNECTIONS SHALL HAVE CONCRETE COLLARS.
10. ALL GRATE INLETS MUST BE H20 RATED GRATES.
11. TOPS OF MANHOLES, JUNCTION BOXES AND GRATES SHALL BE SET FLUSH TO FINISHED SURFACE BASED UPON GRADING PLAN.
12. ALL CONCRETE LINING SHALL DEVELOP A MINIMUM COMPRESSIVE STRENGTH OF 3,000 PSI IN 28 DAYS.
13. CONTRACTOR SHALL ENSURE PROPER DRAINAGE ACROSS ALL PAVED AREAS. PONDING OR BIRD-BATHS EXCEEDING 1/4" IN DEPTH WILL NOT BE ACCEPTABLE AND SHALL BE CORRECTED BY THE CONTRACTOR AT THE CONTRACTOR'S EXPENSE. IF CONTRACTOR HAS CONCERNS ABOUT PROPOSED GRADES AND/OR CONTOURS HE SHALL IMMEDIATELY CONTACT THE ENGINEER.
14. CONTRACTOR SHALL ENSURE POSITIVE DRAINAGE AWAY FROM ALL BUILDINGS AND STRUCTURES. ANY DRAINAGE TOWARDS BUILDINGS AND STRUCTURES WILL NOT BE ACCEPTABLE AND SHALL BE CORRECTED BY THE CONTRACTOR AT THE CONTRACTOR'S EXPENSE. IF CONTRACTOR HAS CONCERNS ABOUT PROPOSED GRADES AND/OR CONTOURS HE SHALL IMMEDIATELY CONTACT THE ENGINEER.

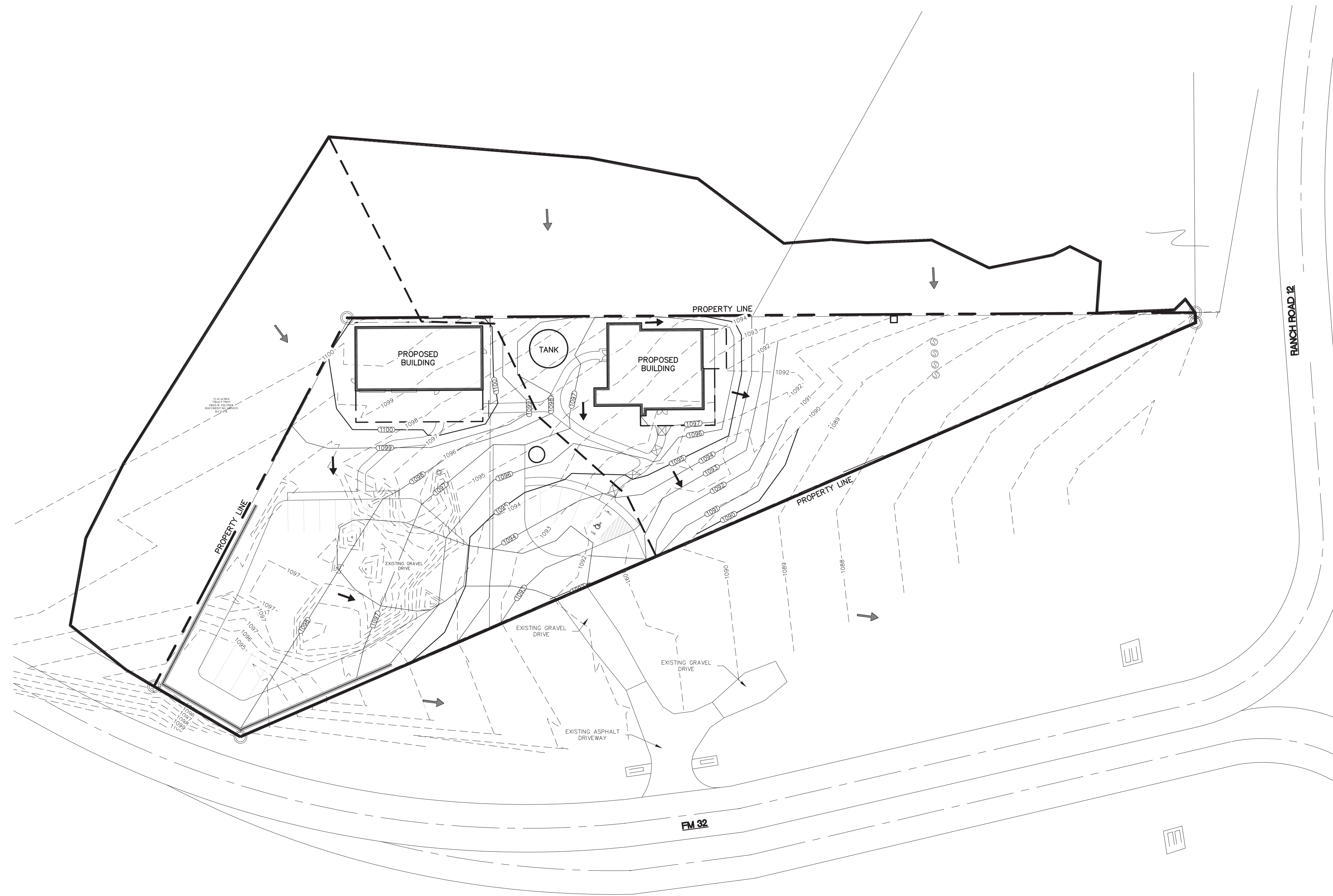

EVER ENGINEERING, LLC
ADVANCED ENGINEERING SERVICES
3201 CHERRY RIDGE DRIVE, SUITE A-106,
SAN ANTONIO, TX 78230
OFFICE (210) 572-9340 FAX (210) 572-9344
WWW.EVERENGINEERING.COM WWW.AES-TX.COM
FIRM NO. E-19197



PROJECT LOCATION:
200 FM 32
SAN MARCOS, TEXAS 78666

DATE: _____
REVISIONS:

DRAINAGE PLAN

PLAT NO.: TBD
DRAWN: CV
CHECKED: ROM
JOB NO.: 22-0106
DATE: DEC. 2022



SHEET:

C8.00

LEGAL DESCRIPTION

1.8558-ACRE TRACT
ABS 25
JAMES ALSTON SURVEY

GRADING NOTES:

- NO WORK SHALL BE COMPLETED WITHIN PUBLIC RIGHT-OF-WAY WITHOUT TxDOT AND/OR CITY PERMIT.
- THE CONTRACTOR IS SPECIFICALLY CAUTIONED THAT THE LOCATION AND/OR ELEVATION OF EXISTING UTILITIES AS SHOWN ON THESE PLANS IS BASED ON RECORDS OF THE VARIOUS UTILITY COMPANIES, AND WHERE POSSIBLE, MEASUREMENTS TAKEN IN THE FIELD. THE INFORMATION IS NOT TO BE RELIED ON AS BEING EXACT OR COMPLETE. THE CONTRACTOR MUST CALL THE APPROPRIATE UTILITY COMPANIES AT LEAST 48 HOURS BEFORE ANY EXCAVATION TO REQUEST EXACT FIELD LOCATION OF UTILITIES. IT SHALL BE THE RESPONSIBILITY OF THE CONTRACTOR TO RELOCATE ALL EXISTING UTILITIES WHICH CONFLICT WITH THE PROPOSED IMPROVEMENTS SHOWN ON THE PLANS OR NOT.
- ALL CUT OR FILL SLOPES SHALL BE 3:1 OR FLATTER UNLESS OTHERWISE NOTED.
- PRECAST STRUCTURES MAY BE USED AT CONTRACTORS OPTION.
- EXISTING GRADE CONTOUR INTERVALS SHOWN AT 1 FOOT INTERVALS.
- PROPOSED GRADE CONTOUR INTERVALS SHOWN AT 1 FOOT INTERVALS.
- IF ANY EXISTING STRUCTURES TO REMAIN ARE DAMAGED DURING CONSTRUCTION IT SHALL BE THE CONTRACTORS RESPONSIBILITY TO REPAIR AND/OR REPLACE THE EXISTING STRUCTURE AS NECESSARY TO RETURN IT TO EXISTING CONDITIONS OR BETTER. (NO SEPARATE PAY ITEM).
- CONTRACTOR SHALL ADJUST AND/OR SAW CUT EXISTING PAVEMENT AS NECESSARY TO ASSURE A SMOOTH FIT AND CONTINUOUS GRADE.
- CONTRACTOR SHALL ASSURE POSITIVE DRAINAGE AWAY FROM BUILDINGS FOR ALL NATURAL AND PAVED AREAS.
- TOPOGRAPHIC INFORMATION TAKEN FROM A TOPOGRAPHIC SURVEY BY LAND SURVEYORS. IF CONTRACTOR DOES NOT ACCEPT EXISTING TOPOGRAPHY AS SHOWN ON THE PLANS, WITHOUT EXCEPTION, HE SHALL SURVEY AND SUBMIT IT TO THE OWNER FOR REVIEW PRIOR TO THE START OF MASS GRADING. ADDITIONALLY, CONTRACTOR SHALL INFORM THE ENGINEER OF TOPOGRAPHY ACCEPTANCE PRIOR TO GRADING COMMENCEMENT.
- ALL UNSURFACED AREAS DISTURBED BY GRADING OPERATION SHALL RECEIVE 4 INCHES OF TOPSOIL. CONTRACTOR SHALL APPLY STABILIZATION FABRIC TO ALL SLOPES 3H:1V OR STEEPER. CONTRACTOR SHALL GRASS DISTURBED AREAS IN ACCORDANCE WITH CITY SPECIFICATIONS UNTIL A HEALTHY STAND OF GRASS IS OBTAINED.
- CONSTRUCTION SHALL COMPLY WITH ALL APPLICABLE GOVERNING CODES AND BE CONSTRUCTED TO SAME.
- ALL PROPOSED ON-SITE CURBS ARE SIX INCHES (6") HIGH FROM GUTTER TO TOP OF CURB UNLESS OTHERWISE NOTED.
- ALL ELEVATIONS AND CONTOURS SHOWN ON THIS GRADING PLAN REFLECT FINISHED GRADES. THE THICKNESS OF PAVEMENT, CURBS, SIDEWALKS, GRASS, TOPSOIL, AND MULCH MUST BE SUBTRACTED TO OBTAIN SUBGRADE ELEVATIONS.
- CONTRACTOR TO OBTAIN GRADES SHOWN HEREON TO +/- 0.1 FEET.
- IN PROPOSED PAVING AREAS, UNLESS NOTED OTHERWISE, IT IS INTENDED THAT THE MINIMUM GRADE IS 1.0% AND THE MAXIMUM GRADE IN ALL PARKING AREAS IS 5% THE MAXIMUM GRADE ON SIDEWALKS IS 5% EXCEPT AT WHEEL CHAIR RAMPS WHERE THE MAXIMUM GRADE IS 8.33% AND THE MAXIMUM CROSS SLOPE ON SIDEWALKS IS 2%. ALL EARTHEN SLOPES SHALL BE A MAXIMUM OF 3:1 AND A MINIMUM OF 2.0% UNLESS OTHERWISE SHOWN. GRADES ADJACENT TO BUILDINGS SHALL BE 7-INCHES (MIN) BELOW FFE AND SHALL SLOPE AWAY FROM THE BUILDING AT 5% FOR THE FIRST 10-FEET.
- ALL MATERIALS AND CONSTRUCTION PROCEDURES WITHIN THE SCOPE OF THIS CONTRACT WHERE NOT SPECIFICALLY COVERED IN THE PROJECT SPECIFICATIONS SHALL CONFORM TO ALL APPLICABLE CITY OF SAN ANTONIO STANDARD SPECIFICATIONS FOR PUBLIC WORKS CONSTRUCTION (LATEST EDITION), TEXAS DEPARTMENT OF TRANSPORTATION STANDARD SPECIFICATIONS (LATEST EDITION), AND SAN ANTONIO PUBLIC WORKS STANDARD SPECIFICATIONS.
- CONTRACTOR SHALL BE RESPONSIBLE FOR COORDINATION WITH ALL NECESSARY UTILITY COMPANIES FOR PROVIDING TEMPORARY UTILITY SERVICES DURING CONSTRUCTION.
- CONTRACTOR SHALL IMMEDIATELY NOTIFY THE ENGINEER OF ANY QUESTIONS THAT MAY ARISE CONCERNING THE INTENT, PLACEMENT, OR LIMITS OF DIMENSIONS OR GRADES NECESSARY FOR CONSTRUCTION OF THIS PROJECT.
- CONTRACTOR SHALL BE RESPONSIBLE FOR ACQUIRING ALL PERMITS, TEST, APPROVALS AND ACCEPTANCES REQUIRED TO COMPLETE CONSTRUCTION OF THIS PROJECT.
- TREE PROTECTION SHALL BE PERFORMED IN ACCORDANCE WITH PROJECT PLANS AND SPECIFICATIONS.
- THE CONTRACTOR SHALL TAKE ALL NECESSARY PRECAUTIONS (USE OF SILT FENCE, ETC.) TO KEEP DRAINAGE AND SILT FROM WASHING ONTO ADJACENT PROPERTY AND INTO EXISTING DRAINAGE STRUCTURES.
- THE CONTRACTOR SHALL CLEAN STREETS, DRIVEWAYS, AND DRAINAGE SYSTEMS ADJACENT TO THE SITE, AS DIRECTED BY THE OWNER AND FOLLOWING THE PROJECTS TPDES POLLUTION PREVENTION PLAN.
- NO ABRUPT CHANGES IN GRADES SHALL OCCUR IN THE ROADWAYS, PARKING AREAS, OR SIDEWALKS.
- PONDING OR BIRD-BATHS EXCEEDING A 1/4" IN DEPTH WILL NOT BE ACCEPTABLE AND SHALL BE CORRECTED BY THE CONTRACTOR.
- BUILDING PAD AND PAVED AREAS SHALL BE CONSTRUCTED IN ACCORDANCE TO THE GEOTECHNICAL REPORT PREPARED BY ROCK ENGINEERING JOB NO. G222625 DATED SEPTEMBER 8, 2022.
- CONTRACTOR SHALL NOTIFY AT LEAST 48 HOURS PRIOR TO STARTING CONSTRUCTION:
1-800-DIG-TESS 1-800-344-8377

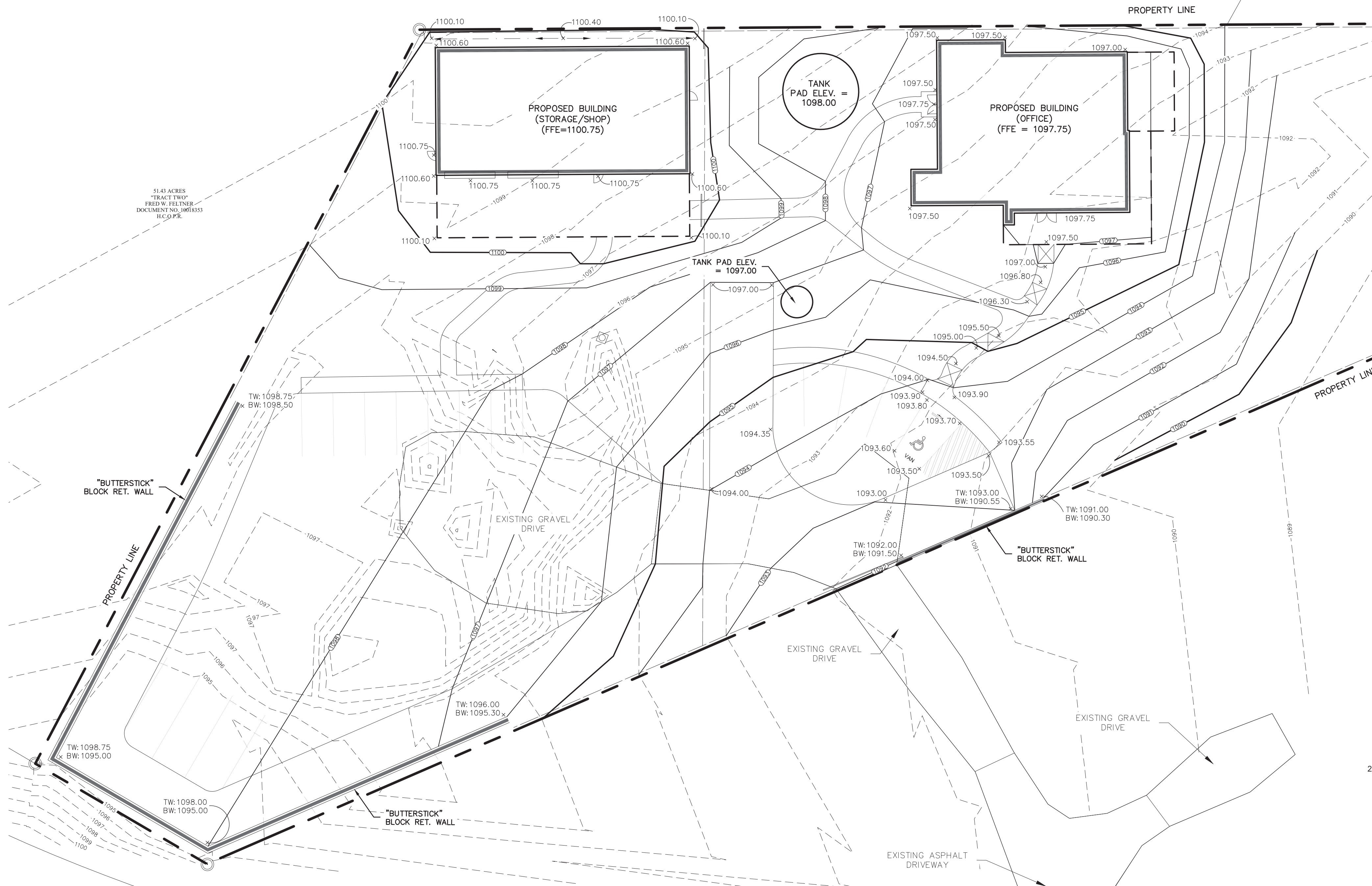

SAVAGE LAND SOLUTIONS HO

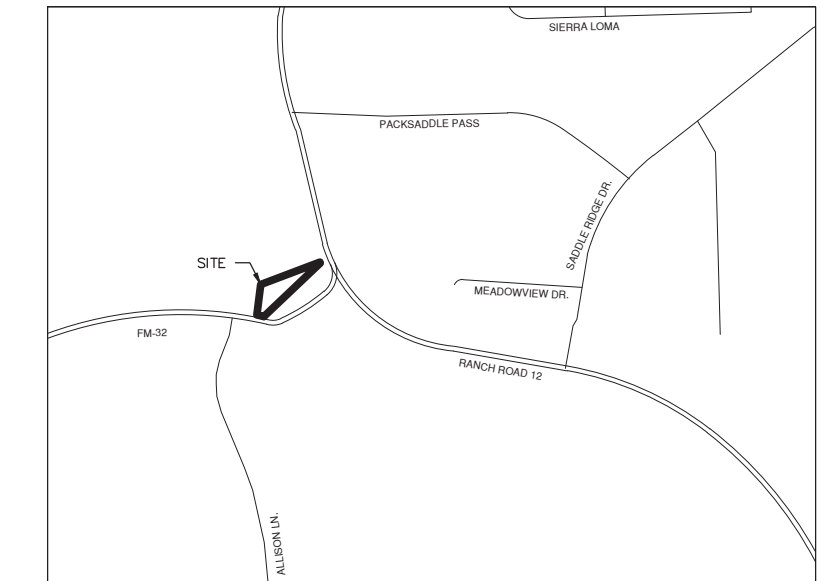

LOCATION MAP
NOT-TO-SCALE

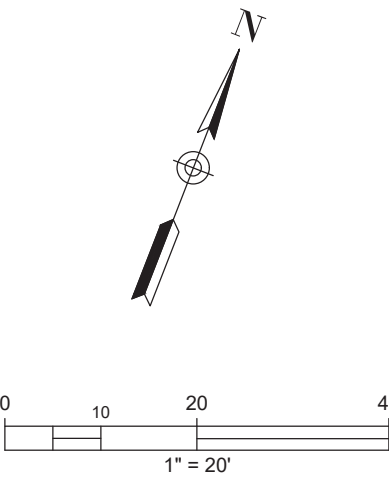

LEGEND

- PROPERTY LINE
- EXISTING CONTOUR
- PROPOSED CONTOUR
- SWALE FLOW LINE
- FLOW ARROW (PROPOSED)
- PROPOSED SPOT ELEV.

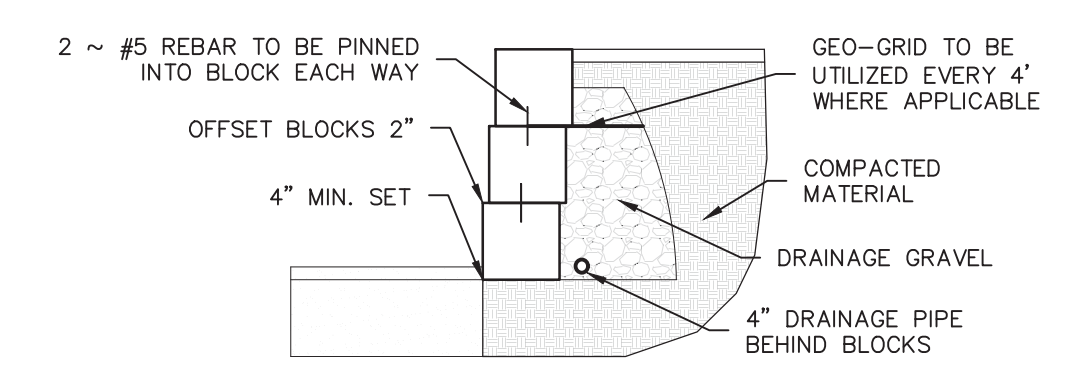

- NOTES:
- LIMESTONE BLOCK TO BE WITHIN 4"
 - CUT OPENING INTO BLOCKS EVERY 15' FOR 4" PIPE 1" JOINT
 - WALL TO BE CONSTRUCTED OUT OF 2'X5' LIMESTONE QUARRY BLOCKS

"BUTTERSTICK" BLOCK WALL DETAIL
(NOT TO SCALE)

EVER ENGINEERING, LLC
ADVANCED ENGINEERING SERVICES
3201 CHERRY RIDGE DRIVE, SUITE A-106,
SAN ANTONIO, TX 78230
OFFICE (210) 572-9340 FAX (210) 572-9344
WWW.EVERENG.COM WWW.AES-TX.COM
FORM NO. E-19197



PROJECT LOCATION:
200 FM 32
SAN MARCOS, TEXAS 78666

DATE	REVISIONS

GRADING PLAN

PLAT NO.:	TBD
DRAWN:	CV
CHECKED:	ROM
JOB NO.:	22-0106
DATE:	DEC. 2022



SHEET:
C7.00

LEGAL DESCRIPTION

1.8558-ACRE TRACT
ABS 25
JAMES ALSTON SURVEY

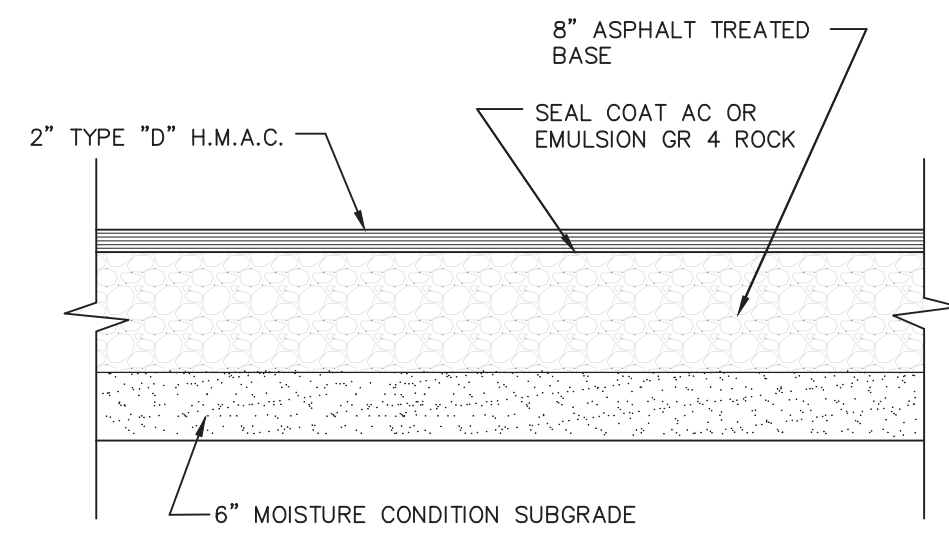

NOTE: IF PI IS GREATER THAN 20, USE LIME TREATMENT

① **ASPHALT PAVEMENT DETAIL**
(NOT TO SCALE)

LAYER	ASPHALT PAVEMENT		CONCRETE PAVEMENT	
	LIGHT	HEAVY	LIGHT	HEAVY
PAVEMENT	2"	3"	5.5"	6.5"
BASE	8"	10"		
SUBGRADE *	6"	6"	6"	6"

PAVEMENT SECTIONS

REFERENCE GEOTECHNICAL ENGINEERING REPORT PREPARED BY ROCK ENGINEERING, ENGINEER'S JOB NO. G222625, DATED 09/8/2022 FOR PAVEMENT MATERIALS AND CONSTRUCTION REQUIREMENTS. CONTRACTOR SHALL MEET OR EXCEED ALL PAVING RECOMMENDATIONS.

- REFERENCE GEOTECH REPORT SUBGRADE NOTES

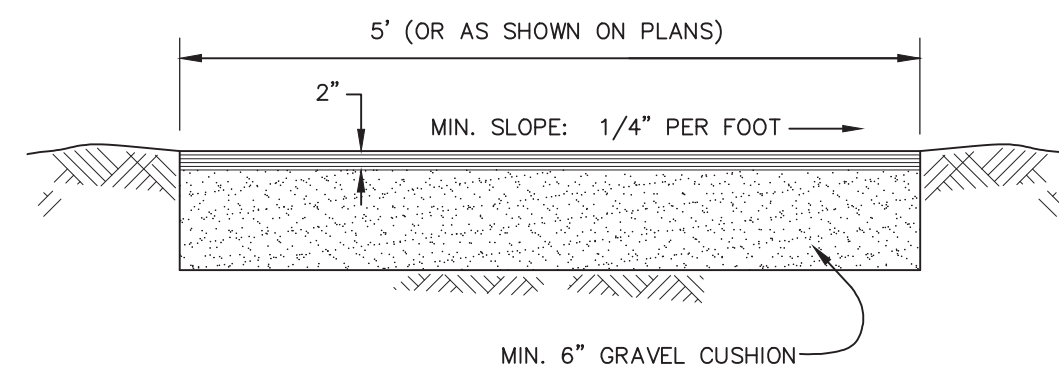

② **ASPHALT SIDEWALK DETAIL**
(NOT TO SCALE)

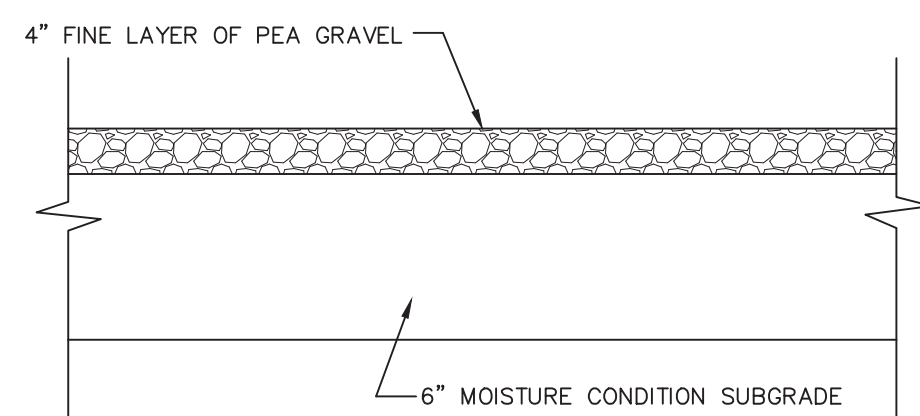

③ **PEA GRAVEL PAVEMENT DETAIL**
(NOT TO SCALE)

SAVAGE LAND SOLUTIONS HO

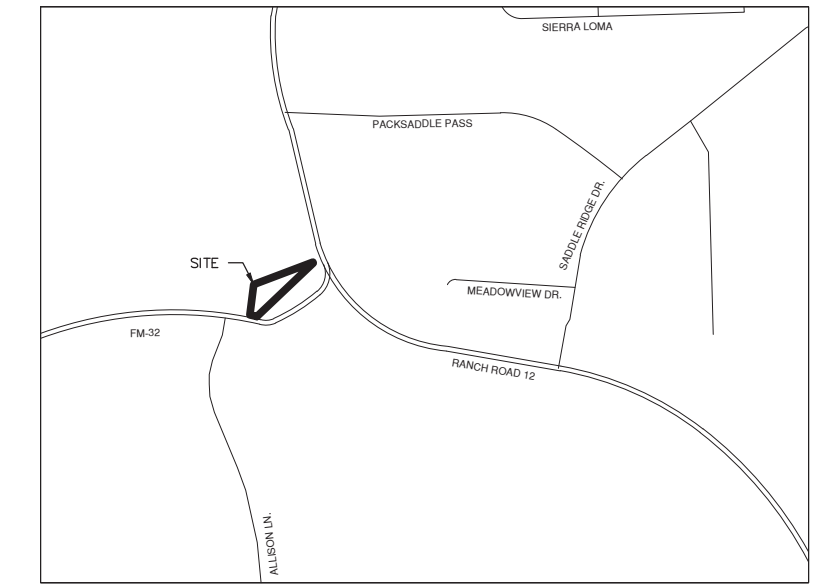

LOCATION MAP
NOT-TO-SCALE

EVER ENGINEERING, LLC
ADVANCED ENGINEERING SERVICES

3201 CHERRY RIDGE DRIVE, SUITE A-106,
SAN ANTONIO, TX 78230
OFFICE (210) 572-9340 • FAX (210) 572-9344
WWW.EVERENG.COM • WWW.AES-TX.COM
PRM NO. E-19197



PROJECT LOCATION:
200 FM 32
SAN MARCOS, TEXAS 78666

DATE

REVISIONS

CIVIL DETAILS

PLAT NO.: TBD
DRAWN: CV
CHECKED: RDM
JOB NO.: 22-0106
DATE: DEC. 2022



SHEET:

C9.00

Z:\projects\2020\DESIGN\CIVIL\C9.00-C9.01 - CIVIL DETAILS.dwg, 12/20/2022 11:52:58 AM, DWS by PMP.pcd



EVER ENGINEERING

Advanced Engineering Services

**Section 6: PERMANENT STORM WATER SECTION (TCEQ-0600)
ATTACHMENT G**

**Savage Land Solutions, LLC.
INSPECTION, MAINTENANCE, REPAIR AND RETROFIT PLAN**

Inspection, maintenance and repair of the proposed permanent BMPs are attached following this sheet.

Vegetative Filter Strips (VFS)

Once a vegetated area is well established, little additional maintenance is generally necessary, the key to establishing a viable vegetated feature is the care and maintenance it receives in the first few months after it is planted. Once established, all vegetated BMPs require some basic maintenance to insure the health of the plants. Per the TCEQ RG-348 (Section 3.5.8) the recommended maintenance plan for vegetative filter strips is as follows:

PEST MANAGEMENT:

Problem insects and weeds will be controlled with minimal or no use of insecticides and herbicides.

SEASONAL MOWING AND LAWN CARE:

If the filter strip is made up of turf grass, it should be mowed as needed to limit vegetation height to 18 inches, using a mulching mower (or removal of clippings). If native grasses are used, the filter may require less frequent mowing, but a minimum of twice annually. Grass clippings and brush debris should not be deposited on vegetated filter strips areas. Regular mowing should also include weed control practices; however, herbicide use should be kept to a minimum (Urbonas et al., 1992). Healthy grass can be maintained without using fertilizers because runoff usually contains sufficient nutrients. Irrigation of the site can help assure a dense and healthy vegetative cover.

INSPECTION:

Inspect filter strips at least twice annually for erosion or damage to vegetation; however, additional inspection after periods of heavy runoff is most desirable. The strip should be

checked for uniformity of grass cover, debris and litter, and areas of sediment accumulation. More frequent inspections of the grass cover during the first few years after establishment will help to determine if any problems are developing, and to plan for long-term restorative maintenance needs. Bare spots and areas of erosion identified during semi-annual inspections must be replanted and 3-92 restored to meet specifications. Construction of a level spreader device may be necessary to reestablish shallow overland flow.

DEBRIS and LITTER REMOVAL:

Trash tends to accumulate in vegetated areas. Any filter strip structures should be kept free of obstructions to reduce floatables being flushed downstream, and for aesthetic reasons. The need for this practice is determined through periodic inspection but should be conducted no less than 4 times per year.

SEDIMENT REMOVAL:

Sediment removal is not normally required in filter strips since the vegetation normally grows through it and binds it to the soil. However, sediment may accumulate along the upstream boundary of the strip preventing uniform overland flow. Excess sediment should be removed by hand or with flat-bottomed shovels.

GRASS RESEEDING AND MULCHING:

A healthy dense grass should be maintained on the filter strip. If areas are eroded, they should be filled, compacted, and reseeded so that the final grade is level. Grass damaged during the sediment removal process should be promptly replaced using the same seed mix used during filter strip establishment. If possible, flow should be diverted from the damaged areas until the grass is firmly established. Bare spots and areas of erosion identified during semi-annual inspections must be replanted and restored to meet specifications. Corrective maintenance, such as weeding, or replanting should be done more frequently in the first two to three years after installation to ensure stabilization. Dense vegetation may require irrigation immediately after planting, and during particularly dry periods, particularly as the vegetation is initially established.

Derrick Downing

Owner (Print Name)

Applicant's Signature

8/24/22
Date



EVER ENGINEERING

Advanced Engineering Services

**Section 6: PERMANENT STORM WATER SECTION (TCEQ-0600)
ATTACHMENT H**

**Savage Land Solutions, LLC.
PILOT – SCALE FIELD TESTING PLAN**

This attachment does not apply to this submittal. The TNRCC (TCEQ) Technical Guidance Manual (TGM) was used to design permanent BMPs and measures on site, and therefore a Pilot-Scale Field Testing Plan is not required.



EVER ENGINEERING

Advanced Engineering Services

**Section 6: PERMANENT STORM WATER SECTION (TCEQ-0600)
ATTACHMENT I**

**Savage Land Solutions, LLC.
MEASURES FOR MINIMIZING SURFACE STREAM CONTAMINATION**

This attachment does not apply to this submittal. There are no surface streams existing on site.



Section 7: Agent Authorization Form (TCEQ-0599)

Savage Land Solutions, LLC.

Agent Authorization Form
For Required Signature
Edwards Aquifer Protection Program
Relating to 30 TAC Chapter 213
Effective June 1, 1999

I _____
DERRICK DOWNING
_____ ,
Print Name
PRESIDENT
_____ ,
Title - Owner/President/Other
of _____
Dark Horse Syndicate, LLC
_____ ,
Corporation/Partnership/Entity Name
have authorized _____
Ever Garza
_____ ,
Print Name of Agent/Engineer
of _____
EVER ENGINEERING, LLC
_____ ,
Print Name of Firm

to represent and act on the behalf of the above named Corporation, Partnership, or Entity for the purpose of preparing and submitting this plan application to the Texas Commission on Environmental Quality (TCEQ) for the review and approval consideration of regulated activities.

I also understand that:

1. The applicant is responsible for compliance with 30 Texas Administrative Code Chapter 213 and any condition of the TCEQ's approval letter. The TCEQ is authorized to assess administrative penalties of up to \$10,000 per day per violation.
2. For those submitting an application who are not the property owner, but who have the right to control and possess the property, additional authorization is required from the owner.
3. Application fees are due and payable at the time the application is submitted. The application fee must be sent to the TCEQ cashier or to the appropriate regional office. The application will not be considered until the correct fee is received by the commission.
4. A notarized copy of the Agent Authorization Form must be provided for the person preparing the application, and this form must accompany the completed application.
5. No person shall commence any regulated activity on the Edwards Aquifer Recharge Zone, Contributing Zone or Transition Zone until the appropriate application for the activity has been filed with and approved by the Executive Director.

SIGNATURE PAGE:

[Handwritten Signature]
Applicant's Signature

Date 8/24/22

THE STATE OF Texas §

County of Harris §

BEFORE ME, the undersigned authority, on this day personally appeared Derrick Downing known to me to be the person whose name is subscribed to the foregoing instrument, and acknowledged to me that (s)he executed same for the purpose and consideration therein expressed.

GIVEN under my hand and seal of office on this 24 day of August, 2022



[Handwritten Signature]
NOTARY PUBLIC
Morgan Paige Irvine
Typed or Printed Name of Notary

MY COMMISSION EXPIRES: 1/29/25



EVER ENGINEERING

Advanced Engineering Services

Section 8: APPLICATION FEE FORM (TCEQ-0574)

Savage Land Solutions, LLC.

Application Fee Form

Texas Commission on Environmental Quality

Name of Proposed Regulated Entity: Savage Land Solutions

Regulated Entity Location: _____

Name of Customer: Derrick Downing

Contact Person: Gerardo Villarreal

Phone: 210-572-9340

Customer Reference Number (if issued): CN N/A

Regulated Entity Reference Number (if issued): RN N/A

Austin Regional Office (3373)

Hays

Travis

Williamson

San Antonio Regional Office (3362)

Bexar

Medina

Uvalde

Comal

Kinney

Application fees must be paid by check, certified check, or money order, payable to the **Texas Commission on Environmental Quality**. Your canceled check will serve as your receipt. **This form must be submitted with your fee payment.** This payment is being submitted to:

Austin Regional Office

San Antonio Regional Office

Mailed to: TCEQ - Cashier

Overnight Delivery to: TCEQ - Cashier

Revenues Section

Mail Code 214

P.O. Box 13088

Austin, TX 78711-3088

12100 Park 35 Circle

Building A, 3rd Floor

Austin, TX 78753

(512)239-0357

Site Location (Check All That Apply):

Recharge Zone

Contributing Zone

Transition Zone

<i>Type of Plan</i>	<i>Size</i>	<i>Fee Due</i>
Water Pollution Abatement Plan, Contributing Zone Plan: One Single Family Residential Dwelling	Acres	\$
Water Pollution Abatement Plan, Contributing Zone Plan: Multiple Single Family Residential and Parks	Acres	\$
Water Pollution Abatement Plan, Contributing Zone Plan: Non-residential	1.855 Acres	\$ 4,000
Sewage Collection System	L.F.	\$
Lift Stations without sewer lines	Acres	\$
Underground or Aboveground Storage Tank Facility	Tanks	\$
Piping System(s)(only)	Each	\$
Exception	Each	\$
Extension of Time	Each	\$

Signature: _____ 

Date: 1/13/23

Application Fee Schedule

Texas Commission on Environmental Quality

Edwards Aquifer Protection Program 30 TAC Chapter 213 (effective 05/01/2008)

Water Pollution Abatement Plans and Modifications

Contributing Zone Plans and Modifications

<i>Project</i>	<i>Project Area in Acres</i>	<i>Fee</i>
One Single Family Residential Dwelling	< 5	\$650
Multiple Single Family Residential and Parks	< 5	\$1,500
	5 < 10	\$3,000
	10 < 40	\$4,000
	40 < 100	\$6,500
	100 < 500	\$8,000
	≥ 500	\$10,000
Non-residential (Commercial, industrial, institutional, multi-family residential, schools, and other sites where regulated activities will occur)	< 1	\$3,000
	1 < 5	\$4,000
	5 < 10	\$5,000
	10 < 40	\$6,500
	40 < 100	\$8,000
	≥ 100	\$10,000

Organized Sewage Collection Systems and Modifications

<i>Project</i>	<i>Cost per Linear Foot</i>	<i>Minimum Fee- Maximum Fee</i>
Sewage Collection Systems	\$0.50	\$650 - \$6,500

Underground and Aboveground Storage Tank System Facility Plans and Modifications

<i>Project</i>	<i>Cost per Tank or Piping System</i>	<i>Minimum Fee- Maximum Fee</i>
Underground and Aboveground Storage Tank Facility	\$650	\$650 - \$6,500

Exception Requests

<i>Project</i>	<i>Fee</i>
Exception Request	\$500

Extension of Time Requests

<i>Project</i>	<i>Fee</i>
Extension of Time Request	\$150



EVER ENGINEERING

Advanced Engineering Services

Section 9: CORE DATA FORM (TCEQ-10400)

Savage Land Solutions, LLC.



TCEQ Use Only

TCEQ Core Data Form

For detailed instructions regarding completion of this form, please read the Core Data Form Instructions or call 512-239-5175.

SECTION I: General Information

1. Reason for Submission (If other is checked please describe in space provided.)		
<input checked="" type="checkbox"/> New Permit, Registration or Authorization (Core Data Form should be submitted with the program application.)		
<input type="checkbox"/> Renewal (Core Data Form should be submitted with the renewal form)	<input type="checkbox"/> Other	
2. Customer Reference Number (if issued)	Follow this link to search for CN or RN numbers in Central Registry**	3. Regulated Entity Reference Number (if issued)
CN has not been issued		RN 110048824

SECTION II: Customer Information

4. General Customer Information		5. Effective Date for Customer Information Updates (mm/dd/yyyy)		12/21/2022	
<input type="checkbox"/> New Customer		<input type="checkbox"/> Update to Customer Information		<input checked="" type="checkbox"/> Change in Regulated Entity Ownership	
<input type="checkbox"/> Change in Legal Name (Verifiable with the Texas Secretary of State or Texas Comptroller of Public Accounts)					
The Customer Name submitted here may be updated automatically based on what is current and active with the Texas Secretary of State (SOS) or Texas Comptroller of Public Accounts (CPA).					
6. Customer Legal Name (If an individual, print last name first: eg: Doe, John)			<i>If new Customer, enter previous Customer below:</i>		
DARK HORSE SYNDICATE, LLC			2226 PROPERTIES LLC		
7. TX SOS/CPA Filing Number		8. TX State Tax ID (11 digits)		9. Federal Tax ID (9 digits)	10. DUNS Number (if applicable)
0804317163		32081967260		87-4231877	068276502
11. Type of Customer:		<input checked="" type="checkbox"/> Corporation		<input type="checkbox"/> Individual	
Government: <input type="checkbox"/> City <input type="checkbox"/> County <input type="checkbox"/> Federal <input type="checkbox"/> State <input type="checkbox"/> Other		<input type="checkbox"/> Sole Proprietorship		Partnership: <input type="checkbox"/> General <input type="checkbox"/> Limited	
12. Number of Employees		<input checked="" type="checkbox"/> 0-20		<input type="checkbox"/> 21-100	
		<input type="checkbox"/> 101-250		<input type="checkbox"/> 251-500	
		<input type="checkbox"/> 501 and higher		13. Independently Owned and Operated?	
				<input checked="" type="checkbox"/> Yes <input type="checkbox"/> No	
14. Customer Role (Proposed or Actual) – as it relates to the Regulated Entity listed on this form. Please check one of the following					
<input checked="" type="checkbox"/> Owner					
<input type="checkbox"/> Operator					
<input type="checkbox"/> Owner & Operator					
<input type="checkbox"/> Occupational Licensee					
<input type="checkbox"/> Responsible Party					
<input type="checkbox"/> Voluntary Cleanup Applicant					
<input type="checkbox"/> Other:					
15. Mailing Address:		P.O. BOX 3108			
City		WUNBERKET		State	TX
ZIP		78676		ZIP + 4	
16. Country Mailing Information (if outside USA)			17. E-Mail Address (if applicable)		
			admin@everenc.com		
18. Telephone Number		19. Extension or Code		20. Fax Number (if applicable)	
(512) 648 - 9431				() -	

SECTION III: Regulated Entity Information

21. General Regulated Entity Information (If 'New Regulated Entity' is selected below this form should be accompanied by a permit application)	
<input checked="" type="checkbox"/> New Regulated Entity <input type="checkbox"/> Update to Regulated Entity Name <input type="checkbox"/> Update to Regulated Entity Information	
The Regulated Entity Name submitted may be updated in order to meet TCEQ Agency Data Standards (removal of organizational endings such as Inc, LP, or LLC).	
22. Regulated Entity Name (Enter name of the site where the regulated action is taking place.)	
Savege Land Solutions	

23. Street Address of the Regulated Entity: <i>(No PO Boxes)</i>	200 Farm to Market 32							
	City	San Marcos	State	TX	ZIP	78666	ZIP + 4	
24. County	HAYS							

Enter Physical Location Description if no street address is provided.

25. Description to Physical Location:								
26. Nearest City					State	Nearest ZIP Code		
27. Latitude (N) In Decimal:				28. Longitude (W) In Decimal:				
Degrees	Minutes	Seconds	Degrees	Minutes	Seconds			
29. Primary SIC Code (4 digits)	30. Secondary SIC Code (4 digits)	31. Primary NAICS Code (5 or 6 digits)		32. Secondary NAICS Code (5 or 6 digits)				
1794		238910						
33. What is the Primary Business of this entity? <i>(Do not repeat the SIC or NAICS description.)</i>								
Site excavation/ Site dirtwork preparation/ Landscaping								
34. Mailing Address:	4 Lakewood Cir							
	City	Wimberley	State	TX	ZIP	78676	ZIP + 4	2155
35. E-Mail Address:	Derrick@Savagelandsolutions.com							
36. Telephone Number	37. Extension or Code			38. Fax Number <i>(if applicable)</i>				
(512)648 9431				() -				

39. TCEQ Programs and ID Numbers Check all Programs and write in the permits/registration numbers that will be affected by the updates submitted on this form. See the Core Data Form instructions for additional guidance.

<input type="checkbox"/> Dam Safety	<input type="checkbox"/> Districts	<input checked="" type="checkbox"/> Edwards Aquifer	<input type="checkbox"/> Emissions Inventory Air	<input type="checkbox"/> Industrial Hazardous Waste
		11000932		
<input type="checkbox"/> Municipal Solid Waste	<input type="checkbox"/> New Source Review Air	<input type="checkbox"/> OSSF	<input type="checkbox"/> Petroleum Storage Tank	<input type="checkbox"/> PWS
<input type="checkbox"/> Sludge	<input type="checkbox"/> Storm Water	<input type="checkbox"/> Title V Air	<input type="checkbox"/> Tires	<input type="checkbox"/> Used Oil
<input type="checkbox"/> Voluntary Cleanup	<input type="checkbox"/> Waste Water	<input type="checkbox"/> Wastewater Agriculture	<input type="checkbox"/> Water Rights	<input type="checkbox"/> Other:

SECTION IV: Preparer Information

40. Name:	Gerardo Villarreal	41. Title:	Project Engineer
42. Telephone Number	43. Ext./Code	44. Fax Number	45. E-Mail Address
(210)572-9344	107	() -	Gvillarreal@everenc.com

SECTION V: Authorized Signature

46. By my signature below, I certify, to the best of my knowledge, that the information provided in this form is true and complete, and that I have signature authority to submit this form on behalf of the entity specified in Section II, Field 6 and/or as required for the updates to the ID numbers identified in field 39.

Company:	Ever Engineering	Job Title:	Professional Engineer
Name <i>(In Print)</i> :	Ever Garza	Phone:	(210)572-9344
Signature:	<i>Ever Garza, P.E.</i>	Date:	12/21/2022