

<b>PHONE</b> 512.930.9412	<b>FAX</b> 512.930.9416
 <b>STEGER BIZZELL</b>	
<b>ADDRESS</b> 1978 S. AUSTIN AVENUE GEORGETOWN, TX 78626	<b>WEB</b> STEGERBIZZELL.COM
<b>SERVICES</b> > > ENGINEERS      > > PLANNERS      > > SURVEYORS	
TEXAS REGISTERED ENGINEERING FIRM F-181	

## Water Pollution Abatement Plan

For

## Airport Road Improvements

In the

City of Georgetown

Williamson County, Texas

Submitted: 7/28/2023

Job Number: 22744-GISD CTE

# Water Pollution Abatement Plan

For

## Airport Road Improvements

In

City of Georgetown

Williamson County, Texas

Job Number: 22744-GISD CTE

Prepared by:

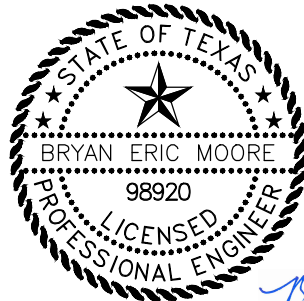

A handwritten signature in blue ink, appearing to read "Bryan Eric Moore", written over a light blue rectangular background.



Texas Registered Engineering Firm-181  
1978 S. Austin Ave  
Georgetown, TX 78626

# Water Pollution Abatement Plan Checklist

- (1) Edwards Aquifer Application Cover Page (TCEQ-20705)**
- (2) General Information Form (TCEQ-0587)**
  - Attachment A - Road Map
  - Attachment B - USGS / Edwards Recharge Zone Map
  - Attachment C - Project Description
- (3) Geologic Assessment Form (TCEQ-0585)**
  - Attachment A - Geologic Assessment Table (TCEQ-0585-Table)
  - Comments to the Geologic Assessment Table
  - Attachment B - Soil Profile and Narrative of Soil Units
  - Attachment C - Stratigraphic Column
  - Attachment D - Narrative of Site Specific Geology
  - Site Geologic Map(s)
  - Table or list for the position of features' latitude/longitude (if mapped using GPS)
- (4) Water Pollution Abatement Plan Application Form (TCEQ-0584)**
  - Attachment A - Factors Affecting Water Quality
  - Attachment B - Volume and Character of Stormwater
  - Attachment C - Suitability Letter from Authorized Agent (if OSSF is proposed)
  - Attachment D - Exception to the Required Geologic Assessment (if requesting an exception)
  - Site Plan
- (5) Temporary Stormwater Section (TCEQ-0602)**
  - Attachment A - Spill Response Actions
  - Attachment B - Potential Sources of Contamination
  - Attachment C - Sequence of Major Activities
  - Attachment D - Temporary Best Management Practices and Measures
  - Attachment E - Request to Temporarily Seal a Feature, if sealing a feature
  - Attachment F - Structural Practices
  - Attachment G - Drainage Area Map
  - Attachment H - Temporary Sediment Pond(s) Plans and Calculations
  - Attachment I - Inspection and Maintenance for BMPs
  - Attachment J - Schedule of Interim and Permanent Soil Stabilization Practices
- (6) Permanent Stormwater Section (TCEQ-0600)**
  - Attachment A - 20% or Less Impervious Cover Waiver, if project is multi-family residential, a school, or a small business and 20% or less impervious cover is proposed for the site
  - Attachment B - BMPs for Upgradient Stormwater
  - Attachment C - BMPs for On-site Stormwater
  - Attachment D - BMPs for Surface Streams
  - Attachment E - Request to Seal Features (if sealing a feature)
  - Attachment F - Construction Plans
  - Attachment G - Inspection, Maintenance, Repair and Retrofit Plan
  - Attachment H - Pilot-Scale Field Testing Plan, if BMPs not based on Complying with the Edwards Aquifer Rules: Technical Guidance for BMPs
  - Attachment I - Measures for Minimizing Surface Stream Contamination
- (7) Agent Authorization Form (TCEQ-0599), if application submitted by agent**
- (8) Application Fee Form (TCEQ-0574)**
- (9) Check Payable to the "Texas Commission on Environmental Quality"**
- (10) Core Data Form (TCEQ-10400)**

# Texas Commission on Environmental Quality

## Edwards Aquifer Application Cover Page

---

### Our Review of Your Application

**The Edwards Aquifer Program staff conducts an administrative and technical review of all applications. The turnaround time for administrative review can be up to 30 days as outlined in 30 TAC 213.4(e). Generally administrative completeness is determined during the intake meeting or within a few days of receipt. The turnaround time for technical review of an administratively complete Edwards Aquifer application is 90 days as outlined in 30 TAC 213.4(e). Please know that the review and approval time is directly impacted by the quality and completeness of the initial application that is received. In order to conduct a timely review, it is imperative that the information provided in an Edwards Aquifer application include final plans, be accurate, complete, and in compliance with [30 TAC 213](#).**

### Administrative Review

1. [Edwards Aquifer applications](#) must be deemed administratively complete before a technical review can begin. To be considered administratively complete, the application must contain completed forms and attachments, provide the requested information, and meet all the site plan requirements. The submitted application and plan sheets should be final plans. Please submit one full-size set of plan sheets with the original application, and half-size sets with the additional copies.

To ensure that all applicable documents are included in the application, the program has developed tools to guide you and web pages to provide all forms, checklists, and guidance. Please visit the below website for assistance: <http://www.tceq.texas.gov/field/eapp>.

2. This Edwards Aquifer Application Cover Page form (certified by the applicant or agent) must be included in the application and brought to the administrative review meeting.
3. Administrative reviews are scheduled with program staff who will conduct the review. Applicants or their authorized agent should call the appropriate regional office, according to the county in which the project is located, to schedule a review. The average meeting time is one hour.
4. In the meeting, the application is examined for administrative completeness. Deficiencies will be noted by staff and emailed or faxed to the applicant and authorized agent at the end of the meeting, or shortly after. Administrative deficiencies will cause the application to be deemed incomplete and returned.

An appointment should be made to resubmit the application. The application is re-examined to ensure all deficiencies are resolved. The application will only be deemed administratively complete when all administrative deficiencies are addressed.

5. If an application is received by mail, courier service, or otherwise submitted without a review meeting, the administrative review will be conducted within 30 days. The applicant and agent will be contacted with the results of the administrative review. If the application is found to be administratively incomplete, it can be retrieved from the regional office or returned by regular mail. If returned by mail, the regional office may require arrangements for return shipping.
6. If the geologic assessment was completed before October 1, 2004 and the site contains “possibly sensitive” features, the assessment must be updated in accordance with the *Instructions to Geologists* (TCEQ-0585 Instructions).

### Technical Review

1. When an application is deemed administratively complete, the technical review period begins. The regional office will distribute copies of the application to the identified affected city, county, and groundwater conservation district whose jurisdiction includes the subject site. These entities and the public have 30 days to provide comments on the application to the regional office. All comments received are reviewed by TCEQ.
2. A site assessment is usually conducted as part of the technical review, to evaluate the geologic assessment and observe existing site conditions. The site must be accessible to our staff. The site boundaries should be clearly marked, features identified in the geologic assessment should be flagged, roadways marked and the alignment of the Sewage Collection System and manholes should be staked at the time the application is submitted. If the site is not marked the application may be returned.

- We evaluate the application for technical completeness and contact the applicant and agent via Notice of Deficiency (NOD) to request additional information and identify technical deficiencies. There are two deficiency response periods available to the applicant. There are 14 days to resolve deficiencies noted in the first NOD. If a second NOD is issued, there is an additional 14 days to resolve deficiencies. If the response to the second notice is not received, is incomplete or inadequate, or provides new information that is incomplete or inadequate, the application must be withdrawn or if not withdrawn the application will be denied and the application fee will be forfeited.
- The program has 90 calendar days to complete the technical review of the application. If the application is technically adequate, such that it complies with the Edwards Aquifer rules, and is protective of the Edwards Aquifer during and after construction, an approval letter will be issued. Construction or other regulated activity may not begin until an approval is issued.

### Mid-Review Modifications

It is important to have final site plans prior to beginning the permitting process with TCEQ to avoid delays.

Occasionally, circumstances arise where you may have significant design and/or site plan changes after your Edwards Aquifer application has been deemed administratively complete by TCEQ. This is considered a “Mid-Review Modification”. Mid-Review Modifications may require redistribution of an application that includes the proposed modifications for public comment.

If you are proposing a Mid-Review Modification, two options are available to you:

- You can withdraw your application, and your fees will be refunded or credited for a resubmittal.
- TCEQ can continue the technical review of the application as it was submitted, and a modification application can be submitted at a later time.

If the application is withdrawn, the resubmitted application will be subject to the administrative and technical review processes and will be treated as a new application. The application will be redistributed to the effected jurisdictions.

Please contact the regional office if you have questions. If your project is located in Williamson, Travis, or Hays County, contact TCEQ’s Austin Regional Office at 512-339-2929. If your project is in Comal, Bexar, Medina, Uvalde, or Kinney County, contact TCEQ’s San Antonio Regional Office at 210-490-3096

Please fill out all required fields below and submit with your application.

<b>1. Regulated Entity Name:</b> Airport Road Improvements				<b>2. Regulated Entity No.:</b> N/A					
<b>3. Customer Name:</b> Georgetown ISD				<b>4. Customer No.:</b> 600916712					
<b>5. Project Type:</b> (Please circle/check one)	<input checked="" type="radio"/> New	Modification		Extension		Exception			
<b>6. Plan Type:</b> (Please circle/check one)	<input checked="" type="radio"/> WPAP	<input type="radio"/> CZP	<input type="radio"/> SCS	<input type="radio"/> UST	<input type="radio"/> AST	<input type="radio"/> EXP	<input type="radio"/> EXT	Technical Clarification	Optional Enhanced Measures
<b>7. Land Use:</b> (Please circle/check one)	<input type="radio"/> Residential		<input checked="" type="radio"/> Non-residential		<b>8. Site (acres):</b>		3.46		
<b>9. Application Fee:</b>	\$4000.00		<b>10. Permanent BMP(s):</b>		Vegetative filter Strips				
<b>11. SCS (Linear Ft.):</b>	0		<b>12. AST/UST (No. Tanks):</b>		N/A				
<b>13. County:</b>	Williamson		<b>14. Watershed:</b>		Berry Creek				

# Application Distribution

Instructions: Use the table below to determine the number of applications required. One original and one copy of the application, plus additional copies (as needed) for each affected incorporated city, county, and groundwater conservation district are required. Linear projects or large projects, which cross into multiple jurisdictions, can require additional copies. Refer to the “Texas Groundwater Conservation Districts within the EAPP Boundaries” map found at:

[http://www.tceq.texas.gov/assets/public/compliance/field\\_ops/eapp/EAPP%20GWCD%20map.pdf](http://www.tceq.texas.gov/assets/public/compliance/field_ops/eapp/EAPP%20GWCD%20map.pdf)

For more detailed boundaries, please contact the conservation district directly.

<b>Austin Region</b>			
<b>County:</b>	<b>Hays</b>	<b>Travis</b>	<b>Williamson</b>
Original (1 req.)	—	—	✗
Region (1 req.)	—	—	✗
County(ies)	—	—	✗
Groundwater Conservation District(s)	<input type="checkbox"/> Edwards Aquifer Authority <input type="checkbox"/> Barton Springs/ Edwards Aquifer <input type="checkbox"/> Hays Trinity <input type="checkbox"/> Plum Creek	<input type="checkbox"/> Barton Springs/ Edwards Aquifer	NA
City(ies) Jurisdiction	<input type="checkbox"/> Austin <input type="checkbox"/> Buda <input type="checkbox"/> Dripping Springs <input type="checkbox"/> Kyle <input type="checkbox"/> Mountain City <input type="checkbox"/> San Marcos <input type="checkbox"/> Wimberley <input type="checkbox"/> Woodcreek	<input type="checkbox"/> Austin <input type="checkbox"/> Bee Cave <input type="checkbox"/> Pflugerville <input type="checkbox"/> Rollingwood <input type="checkbox"/> Round Rock <input type="checkbox"/> Sunset Valley <input type="checkbox"/> West Lake Hills	<input type="checkbox"/> Austin <input type="checkbox"/> Cedar Park <input type="checkbox"/> Florence <input checked="" type="checkbox"/> Georgetown <input type="checkbox"/> Jerrell <input type="checkbox"/> Leander <input type="checkbox"/> Liberty Hill <input type="checkbox"/> Pflugerville <input type="checkbox"/> Round Rock

<b>San Antonio Region</b>					
<b>County:</b>	<b>Bexar</b>	<b>Comal</b>	<b>Kinney</b>	<b>Medina</b>	<b>Uvalde</b>
Original (1 req.)	—	—	—	—	—
Region (1 req.)	—	—	—	—	—
County(ies)	—	—	—	—	—
Groundwater Conservation District(s)	<input type="checkbox"/> Edwards Aquifer Authority <input type="checkbox"/> Trinity-Glen Rose	<input type="checkbox"/> Edwards Aquifer Authority	<input type="checkbox"/> Kinney	<input type="checkbox"/> EAA <input type="checkbox"/> Medina	<input type="checkbox"/> EAA <input type="checkbox"/> Uvalde
City(ies) Jurisdiction	<input type="checkbox"/> Castle Hills <input type="checkbox"/> Fair Oaks Ranch <input type="checkbox"/> Helotes <input type="checkbox"/> Hill Country Village <input type="checkbox"/> Hollywood Park <input type="checkbox"/> San Antonio (SAWS) <input type="checkbox"/> Shavano Park	<input type="checkbox"/> Bulverde <input type="checkbox"/> Fair Oaks Ranch <input type="checkbox"/> Garden Ridge <input type="checkbox"/> New Braunfels <input type="checkbox"/> Schertz	NA	<input type="checkbox"/> San Antonio ETJ (SAWS)	NA

I certify that to the best of my knowledge, that the application is complete and accurate. This application is hereby submitted to TCEQ for administrative review and technical review.

Bryan E. Moore, P.E.

Print Name of Customer/Authorized Agent



7/28/2023

Signature of Customer/Authorized Agent

Date

**\*\*FOR TCEQ INTERNAL USE ONLY\*\***

Date(s) Reviewed:		Date Administratively Complete:	
Received From:		Correct Number of Copies:	
Received By:		Distribution Date:	
EAPP File Number:		Complex:	
Admin. Review(s) (No.):		No. AR Rounds:	
Delinquent Fees (Y/N):		Review Time Spent:	
Lat./Long. Verified:		SOS Customer Verification:	
Agent Authorization Complete/Notarized (Y/N):		Fee Check:	Payable to TCEQ (Y/N):
Core Data Form Complete (Y/N):			Signed (Y/N):
Core Data Form Incomplete Nos.:			Less than 90 days old (Y/N):

# General Information Form

## Texas Commission on Environmental Quality

For Regulated Activities on the Edwards Aquifer Recharge and Transition Zones and Relating to 30 TAC §213.4(b) & §213.5(b)(2)(A), (B) Effective June 1, 1999

**To ensure that the application is administratively complete, confirm that all fields in the form are complete, verify that all requested information is provided, consistently reference the same site and contact person in all forms in the application, and ensure forms are signed by the appropriate party.**

**Note: Including all the information requested in the form and attachments contributes to more streamlined technical reviews.**

## Signature

To the best of my knowledge, the responses to this form accurately reflect all information requested concerning the proposed regulated activities and methods to protect the Edwards Aquifer. This **General Information Form** is hereby submitted for TCEQ review. The application was prepared by:

Print Name of Customer/Agent: Georgetown ISD / Steger Bizzell, Bryan Moore, P.E.

Date: 7/28/2023

Signature of Customer/Agent:



---

## Project Information

1. Regulated Entity Name: Airport Road Improvements
2. County: Williamson
3. Stream Basin: Berry Creek
4. Groundwater Conservation District (If applicable): \_\_\_\_\_
5. Edwards Aquifer Zone:
  - Recharge Zone
  - Transition Zone
6. Plan Type:
  - WPAP
  - SCS
  - Modification
  - AST
  - UST
  - Exception Request



7. Customer (Applicant):

Contact Person: Jimmy Jones  
Entity: Georgetown ISD  
Mailing Address: 507 E University Ave  
City, State: Georgetown, TX Zip: 78626  
Telephone: 512-943-5129 FAX: N/A  
Email Address: jonesj10@georgetownisd.org

8. Agent/Representative (If any):

Contact Person: Bryan Moore, P.E.  
Entity: Steger Bizzell  
Mailing Address: 1978 S. Austin Ave  
City, State: Georgetown, TX Zip: 78626  
Telephone: 512-930-9412 Fax: N/A  
Email Address: bmoore@stegerbizzell.com

9. Project Location:

- The project site is located inside the city limits of Georgetown.
- The project site is located outside the city limits but inside the ETJ (extra-territorial jurisdiction) of \_\_\_\_\_.
- The project site is not located within any city's limits or ETJ.

10.  The location of the project site is described below. The description provides sufficient detail and clarity so that the TCEQ's Regional staff can easily locate the project and site boundaries for a field investigation.

FROM AUSTIN: TRAVELING NORTH ON I-35, TAKE EXIT 264 TO N AUSTIN AVE. TURN LEFT ONTO N AUSTIN AVE AND CONTINUE FOR APPROXIMATELY 0.3 MILES. TURN LEFT ONTO LAKEWAY DR AND CONTINUE ONTO COUNTRY RD 190 A FOR APPROXIMATELY 0.1 MILES. TURN RIGHT ONTO AIRPORT ROAD AND CONTINUE FOR APPROXIMATELY 1.0 MILE AND THE SITE WILL BE ON THE LEFT.

11.  **Attachment A – Road Map.** A road map showing directions to and the location of the project site is attached. The project location and site boundaries are clearly shown on the map.
12.  **Attachment B - USGS / Edwards Recharge Zone Map.** A copy of the official 7 ½ minute USGS Quadrangle Map (Scale: 1" = 2000') of the Edwards Recharge Zone is attached. The map(s) clearly show:
- Project site boundaries.
  - USGS Quadrangle Name(s).
  - Boundaries of the Recharge Zone (and Transition Zone, if applicable).
  - Drainage path from the project site to the boundary of the Recharge Zone.
13.  **The TCEQ must be able to inspect the project site or the application will be returned.** Sufficient survey staking is provided on the project to allow TCEQ regional staff to locate

the boundaries and alignment of the regulated activities and the geologic or manmade features noted in the Geologic Assessment.

Survey staking will be completed by this date: 04/29/2022

14.  **Attachment C – Project Description.** Attached at the end of this form is a detailed narrative description of the proposed project. The project description is consistent throughout the application and contains, at a minimum, the following details:

- Area of the site
- Offsite areas
- Impervious cover
- Permanent BMP(s)
- Proposed site use
- Site history
- Previous development
- Area(s) to be demolished

15. Existing project site conditions are noted below:

- Existing commercial site
- Existing industrial site
- Existing residential site
- Existing paved and/or unpaved roads
- Undeveloped (Cleared)
- Undeveloped (Undisturbed/Uncleared)
- Other: \_\_\_\_\_

### ***Prohibited Activities***

16.  I am aware that the following activities are prohibited on the Recharge Zone and are not proposed for this project:

- (1) Waste disposal wells regulated under 30 TAC Chapter 331 of this title (relating to Underground Injection Control);
- (2) New feedlot/concentrated animal feeding operations, as defined in 30 TAC §213.3;
- (3) Land disposal of Class I wastes, as defined in 30 TAC §335.1;
- (4) The use of sewage holding tanks as parts of organized collection systems; and
- (5) New municipal solid waste landfill facilities required to meet and comply with Type I standards which are defined in §330.41(b), (c), and (d) of this title (relating to Types of Municipal Solid Waste Facilities).
- (6) New municipal and industrial wastewater discharges into or adjacent to water in the state that would create additional pollutant loading.

17.  I am aware that the following activities are prohibited on the Transition Zone and are not proposed for this project:

- (1) Waste disposal wells regulated under 30 TAC Chapter 331 (relating to Underground Injection Control);
- (2) Land disposal of Class I wastes, as defined in 30 TAC §335.1; and
- (3) New municipal solid waste landfill facilities required to meet and comply with Type I standards which are defined in §330.41 (b), (c), and (d) of this title.

**Administrative Information**

18. The fee for the plan(s) is based on:

- For a Water Pollution Abatement Plan or Modification, the total acreage of the site where regulated activities will occur.
- For an Organized Sewage Collection System Plan or Modification, the total linear footage of all collection system lines.
- For a UST Facility Plan or Modification or an AST Facility Plan or Modification, the total number of tanks or piping systems.
- A request for an exception to any substantive portion of the regulations related to the protection of water quality.
- A request for an extension to a previously approved plan.

19.  Application fees are due and payable at the time the application is filed. If the correct fee is not submitted, the TCEQ is not required to consider the application until the correct fee is submitted. Both the fee and the Edwards Aquifer Fee Form have been sent to the Commission's:

- TCEQ cashier
- Austin Regional Office (for projects in Hays, Travis, and Williamson Counties)
- San Antonio Regional Office (for projects in Bexar, Comal, Kinney, Medina, and Uvalde Counties)

20.  Submit one (1) original and one (1) copy of the application, plus additional copies as needed for each affected incorporated city, groundwater conservation district, and county in which the project will be located. The TCEQ will distribute the additional copies to these jurisdictions. The copies must be submitted to the appropriate regional office.

21.  No person shall commence any regulated activity until the Edwards Aquifer Protection Plan(s) for the activity has been filed with and approved by the Executive Director.

P:\22000-22999\22744 GISD CTE\01-Airport Road\Documents\TCEQ\WPAP\Attachment A - ROAD MAP AIRPORT.dwg, Layout1, 5/26/2023 3:28:12 PM

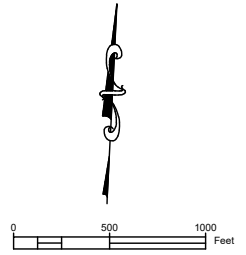
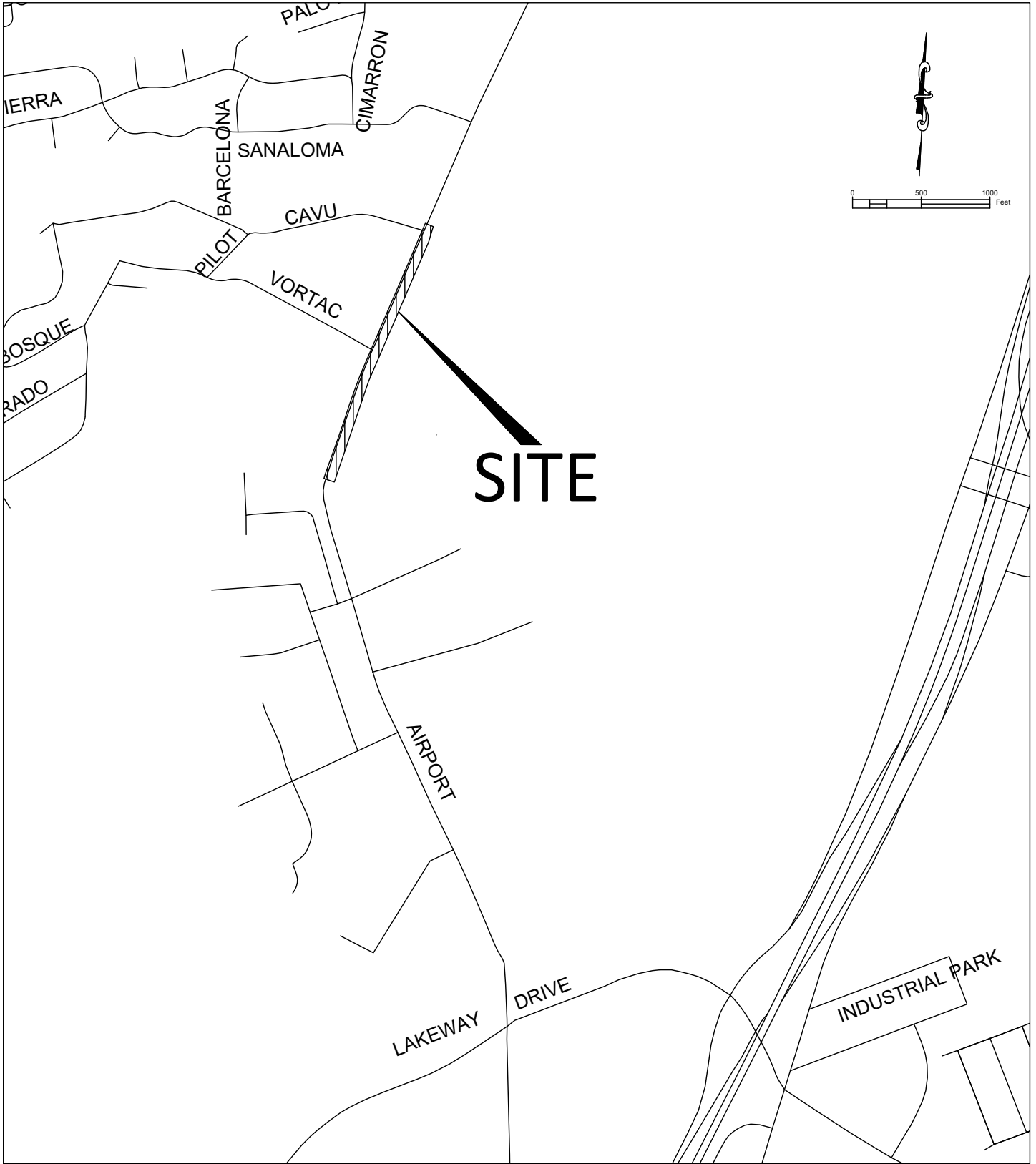

**ATTACHMENT A  
ROAD MAP**



ADDRESS		1978 S. AUSTIN AVENUE	GEORGETOWN, TX 78626	
METRO	512.930.9412	TEXAS REGISTERED ENGINEERING FIRM F-181 TBPLS FIRM No.10003700	WEB	STEBERBIZZELL.COM
SERVICES		>>ENGINEERS >>PLANNERS >>SURVEYORS		

DATE: 5/30/2023

JOB NO. 22744

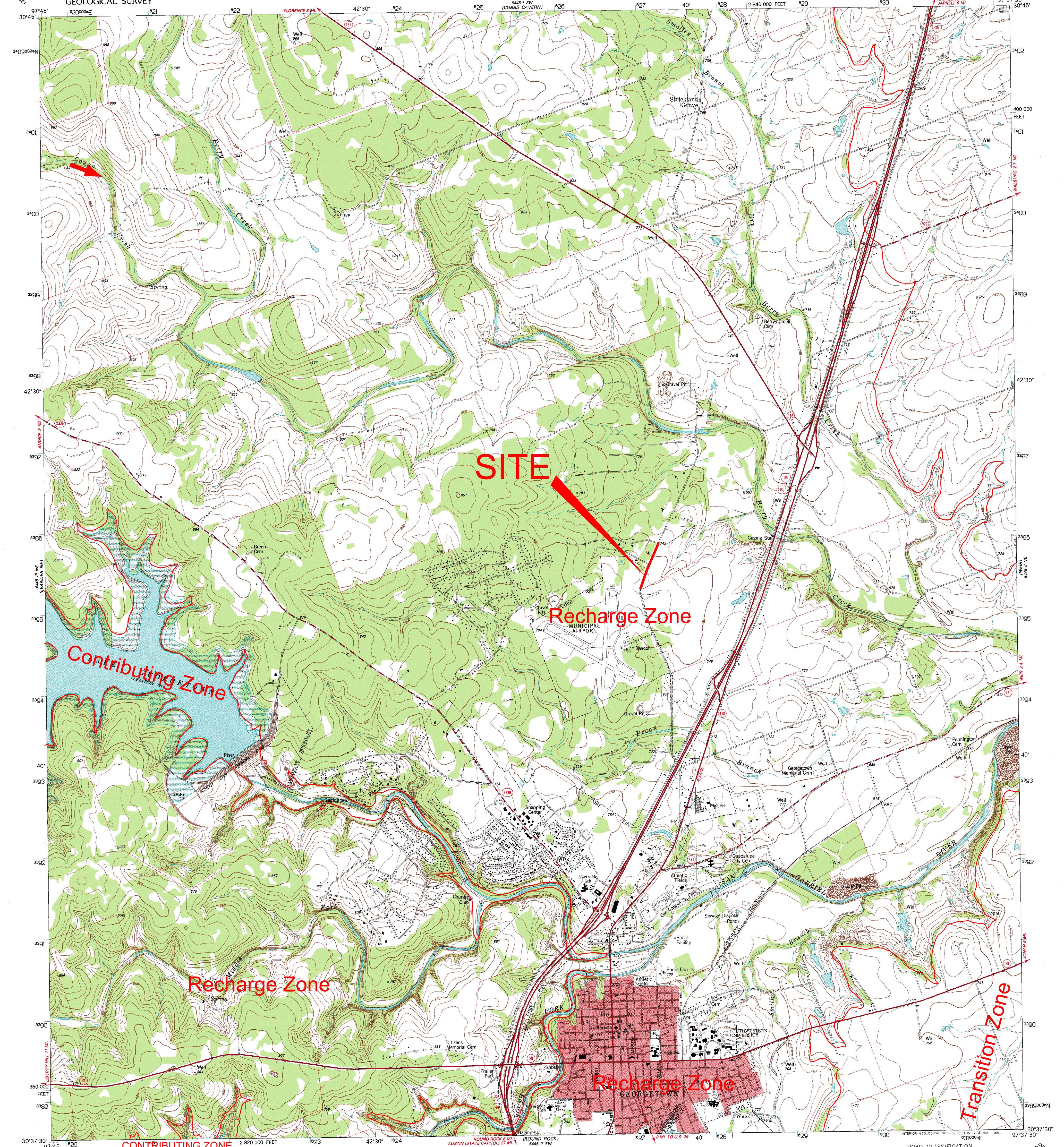

**SITE**

**Recharge Zone**

**Contributing Zone**

**Recharge Zone**

**Recharge Zone**

**Transition Zone**

**CONTRIBUTING ZONE**

**AUSTIN (STATE CAPITOL) 27 MI.**

**ROUND ROCK 8 MI.**

**14 MI. TO U.S. 39**

**INTERIOR GEOLOGICAL SURVEY**

P:\22000-22999\22744\_GIS\CTE\01\_Airport\_Roads\Attachment B-USGS\_Airport\_Map\_Sheet\_3\_7262023\_9-40-27\_AM

Produced by the United States Geological Survey  
Control by USGS and NOS/NOAA  
Compiled from aerial photographs taken 1974. Field checked 1975  
Map edited 1982  
North American Datum of 1927 (NAD 27). Projection and  
10000-foot ticks. Texas Coordinate System, central zone  
(Lambert Conformal Conic)  
Blue 1000-meter Universal Transverse Mercator ticks, zone 14  
North American Datum of 1983 (NAD 83) is shown by dashed  
corner ticks. The values of the shift between NAD 27 and NAD 83  
for 7.5-minute intersections are obtainable from National Geodetic  
Survey NADCON software  
Red tint indicates areas in which only landmark buildings are shown  
Fine red dashed lines indicate selected fence lines  
Areas covered by dashed light-blue pattern are subject to  
controlled inundation

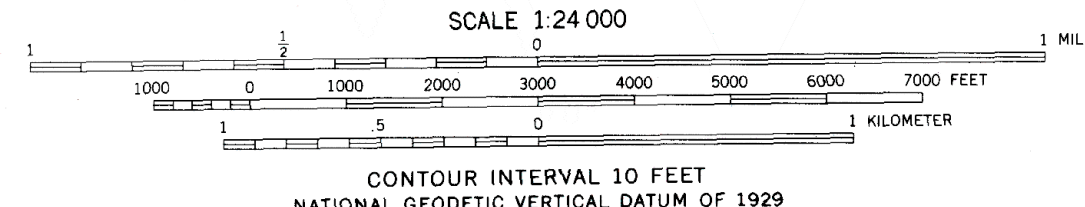
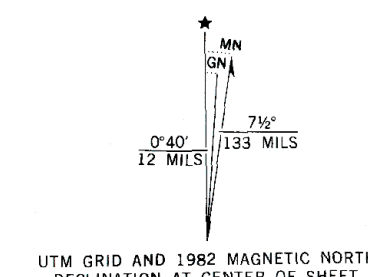

**AIRPORT ROAD IMPROVEMENTS**  
CITY OF GEORGETOWN,  
WILLIAMSON COUNTY, TEXAS



3097-313

ROAD CLASSIFICATION

Primary highway, hard surface	Light-duty road, hard or improved surface
Secondary highway, hard surface	Unimproved road
Interstate Route	U.S. Route
	State Route

GEORGETOWN, TX  
30097-F6-TF-024  
1982  
JOB No. 22744



UNITED STATES  
DEPARTMENT OF THE INTERIOR  
GEOLOGICAL SURVEY

WEIR QUADRANGLE  
TEXAS-WILLIAMSON CO.  
7.5 MINUTE SERIES (TOPOGRAPHIC)  
NE 4 ROUND ROCK 18 QUADRANGLE

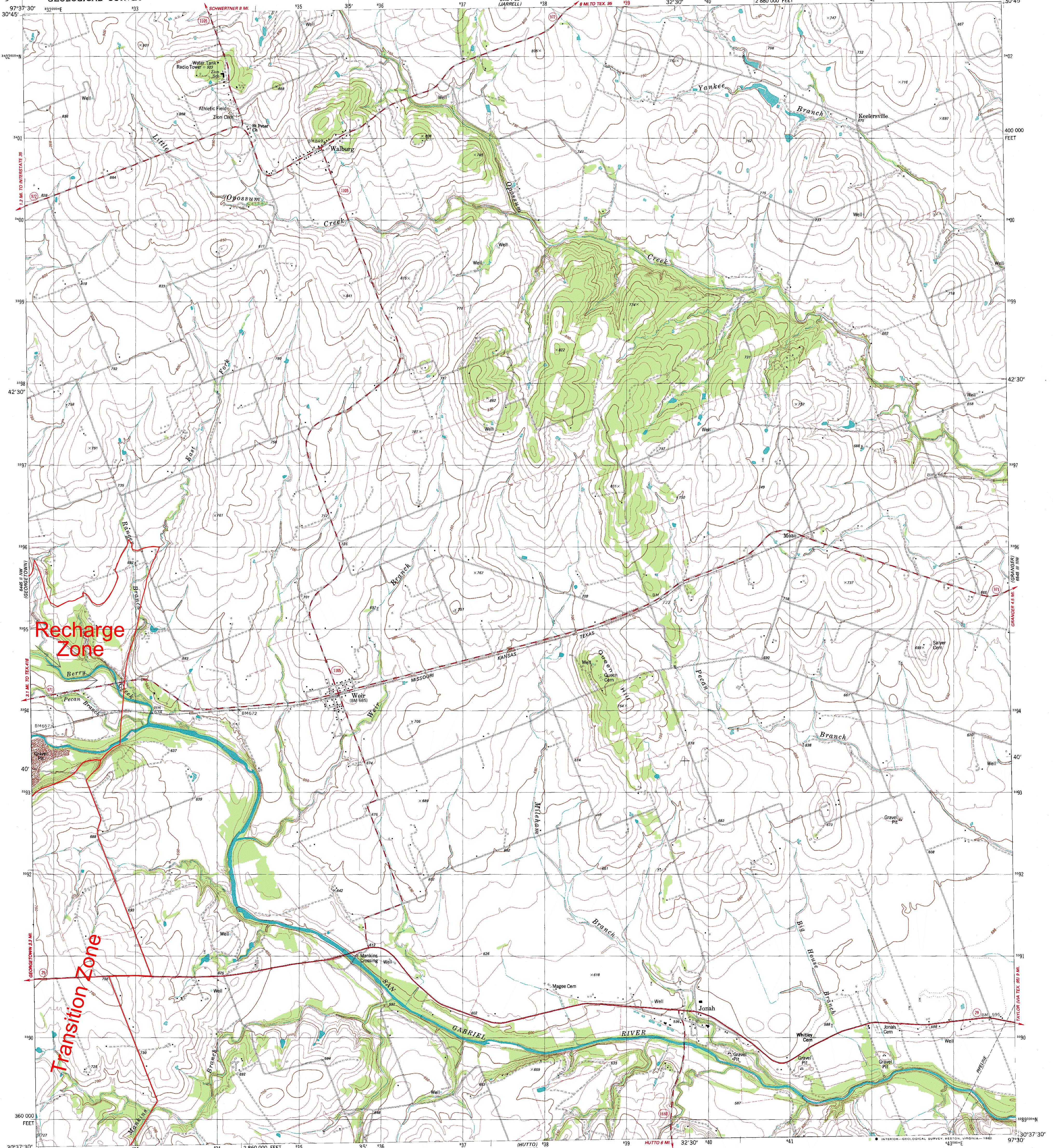

Mapped, edited, and published by the Geological Survey  
Control by USGS and NOS/NOAA  
Topography by photogrammetric methods from aerial photographs taken 1974. Field checked 1975. Map edited 1982  
Projection and 10,000-foot grid ticks: Texas coordinate system, central zone (Lambert conformal conic) 1000-meter Universal Transverse Mercator grid, zone 14 1927 North American datum  
To place on the predicted North American Datum 1983 move the projection lines 17 meters south and 28 meters east as shown by dashed corner ticks  
Fine red dashed lines indicate selected fence lines

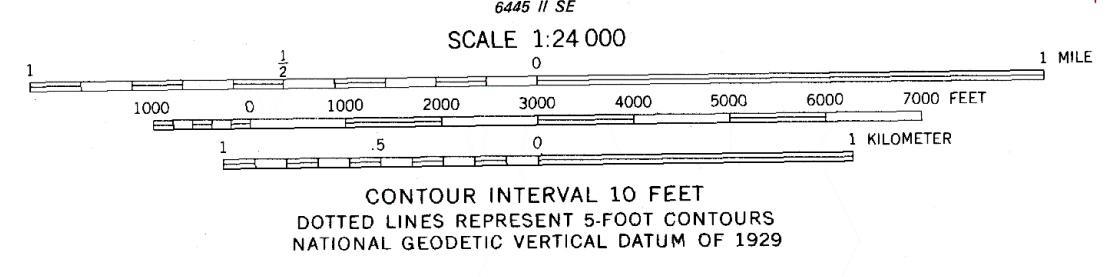

ROAD CLASSIFICATION

Primary highway, hard surface	Light-duty road, hard or improved surface
Secondary highway, hard surface	Unimproved road
Interstate Route	U. S. Route
	State Route

**AIRPORT ROAD IMPROVEMENTS**  
CITY OF GEORGETOWN,  
WILLIAMSON COUNTY, TEXAS



QUADRANGLE LOCATION  
3097-314

WEIR, TEX.  
NE 4 ROUND ROCK 18 QUADRANGLE  
N3037.5-W97307.5  
1982  
JOB No. 22744

### **Attachment C – Project Description**

This project consists of a section of Minor Arterial Road known as Airport Road Improvements. The limits of the Airport Road Improvements WPAP site are approximately 3.46 acres. The site is located in Georgetown, Texas and is south of the intersection of Vortac Lane and Airport Road. The site is currently bounded by undeveloped land to the west and undeveloped land to the east. The site consists of an existing paved road with no shoulders.

The WPAP application will include paving, grading, and drainage improvements to for Airport Road Improvements. The neighborhood includes 0 lots.

Suspended solid and pollutant removal will be done by the use of Vegetative Filter Strips to achieve an eighty-five percent removal. The site generally drains from north to south. Any offsite areas adjacent to the project limits will be diverted around the proposed Airport Road Improvements.

The limit Airport Road Improvements WPAP is 3.46 acres. The proposed impervious cover within the road will be 2.2 acres and 63.65%.

# Geologic Assessment

Texas Commission on Environmental Quality

For Regulated Activities on The Edwards Aquifer Recharge/transition Zones and Relating to 30 TAC §213.5(b)(3), Effective June 1, 1999

*To ensure that the application is administratively complete, confirm that all fields in the form are complete, verify that all requested information is provided, consistently reference the same site and contact person in all forms in the application, and ensure forms are signed by the appropriate party.*

*Note: Including all the information requested in the form and attachments contributes to more streamlined technical reviews.*

## Signature

To the best of my knowledge, the responses to this form accurately reflect all information requested concerning the proposed regulated activities and methods to protect the Edwards Aquifer. My signature certifies that I am qualified as a geologist as defined by 30 TAC Chapter 213.

Print Name of Geologist: Russell C Ford

Telephone: 512 442-1122

Date: 10/16/20

Fax: \_\_\_\_\_

Represented by: Frattolillo Consultants, Inc. (Name of Company and TBPG or TBPE registration number)

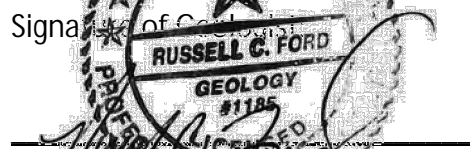
Signature of Geologist: 

Regulated Activity: CTE Center Tract, Airport Road and Vortac Lane, Georgetown, Texas

11/10/2020

## Project Information

1. Date(s) Geologic Assessment was performed: 10/8/2020

2. Type of Project:

WPAP

AST

SCS

UST

3. Location of Project:

Recharge Zone

Transition Zone

Contributing Zone within the Transition Zone



4.  Attachment A - Geologic Assessment Table. Completed Geologic Assessment Table (Form TCEQ-0585-Table) is attached.
5.  Soil cover on the project site is summarized in the table below and uses the SCS Hydrologic Soil Groups\* (Urban Hydrology for Small Watersheds, Technical Release No. 55, Appendix A, Soil Conservation Service, 1986). If there is more than one soil type on the project site, show each soil type on the site Geologic Map or a separate soils map.

Table 1 - Soil Units, Infiltration Characteristics and Thickness

Soil Name	Group*	Thickness(feet)
EeD	D	0-1
DoC	D	0-2
DnC	D	0-5

\* Soil Group Definitions (Abbreviated)

- A. Soils having a high infiltration rate when thoroughly wetted.
- B. Soils having a moderate infiltration rate when thoroughly wetted.
- C. Soils having a slow infiltration rate when thoroughly wetted.
- D. Soils having a very slow infiltration rate when thoroughly wetted.

6.  Attachment B – Stratigraphic Column. A stratigraphic column showing formations, members, and thicknesses is attached. The outcropping unit, if present, should be at the top of the stratigraphic column. Otherwise, the uppermost unit should be at the top of the stratigraphic column.
7.  Attachment C – Site Geology. A narrative description of the site specific geology including any features identified in the Geologic Assessment Table, a discussion of the potential for fluid movement to the Edwards Aquifer, stratigraphy, structure(s), and karst characteristics is attached.
8.  Attachment D – Site Geologic Map(s). The Site Geologic Map must be the same scale as the applicant's Site Plan. The minimum scale is 1": 400'  
 Applicant's Site Plan Scale: 1" = \_'  
 Site Geologic Map Scale: 1" = 100'  
 Site Soils Map Scale (if more than 1 soil type): 1" = 100'
9. Method of collecting positional data:
  - Global Positioning System (GPS) technology.
  - Other method(s). Please describe method of data collection: \_\_\_\_\_
10.  The project site and boundaries are clearly shown and labeled on the Site Geologic Map.
11.  Surface geologic units are shown and labeled on the Site Geologic Map.

12.  Geologic or manmade features were discovered on the project site during the field investigation. They are shown and labeled on the Site Geologic Map and are described in the attached Geologic Assessment Table.
- Geologic or manmade features were not discovered on the project site during the field investigation.
13.  The Recharge Zone boundary is shown and labeled, if appropriate.
14. All known wells (test holes, water, oil, unplugged, capped and/or abandoned, etc.): If applicable, the information must agree with Item No. 20 of the WPAP Application Section.
- There are \_\_\_\_\_ (#) wells present on the project site and the locations are shown and labeled. (Check all of the following that apply.)
- The wells are not in use and have been properly abandoned.
- The wells are not in use and will be properly abandoned.
- The wells are in use and comply with 16 TAC Chapter 76.
- There are no wells or test holes of any kind known to exist on the project site.

### *Administrative Information*

15.  Submit one (1) original and one (1) copy of the application, plus additional copies as needed for each affected incorporated city, groundwater conservation district, and county in which the project will be located. The TCEQ will distribute the additional copies to these jurisdictions. The copies must be submitted to the appropriate regional office.

**ATTACHMENT A NO FEATURES OBSERVED**

GEOLOGIC ASSESSMENT TABLE		PROJECT NAME: CTE Center Tract, Airport Road and Vortac Lane, Georgetown, Texas														
LOCATION			FEATURE CHARACTERISTICS					EVALUATION PHYSICAL SETTING								
1A	1B*	1C*	2A	2B	3	4	5	5A	6	7	8A	8B	9	10	11	12
FEATURED	LATITUDE	LONGITUDE	FEATURE TYPE	POINTS	FORMATION	DIMENSIONS (FEET)	TREND (DEGREES)	DOM	DENSITY (NO/FT)	APERTURE (FEET)	INFILL	RELATIVE INFILTRATION RATE	TOTAL SENSITIVITY	SENSITIVITY	CATCHMENT AREA (ACRES)	TOPOGRAPHY

\* DATUM NAD27

2A TYPE	TYPE	2B POINTS
C	Cave	30
SC	Solution cavity	20
SF	Solution-enlarged fracture(s)	20
F	Fault	20
O	Other natural bedrock features	5
MB	Manmade feature in bedrock	30
SW	Swallow hole	
SH	Sinkhole	
CD	Non-karst closed depression	
Z	Zone, clustered or aligned features	

8A INFILLING
N None, exposed bedrock
C Coarse - cobbles, breakdown, sand, gravel
O Loose or soft mud or soil, organics, leaves, sticks, dark colors
F Fines, compacted clay-rich sediment, soil profile, gray or red colors
V Vegetation. Give details in narrative description
FS Flowstone, cements, cave deposits
X Other materials

I have reviewed this document and it complies with the Texas Natural Resource Conservation Commission's Instructions to Geologists. The information in this document and is a true representation of the conditions observed in the field.

My signature: \_\_\_\_\_ Date: \_\_\_\_\_

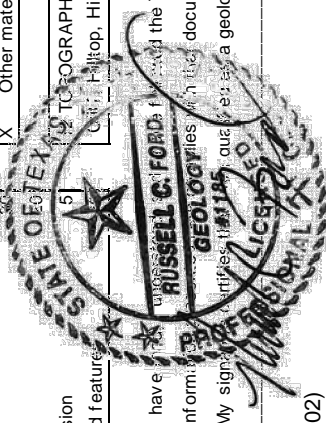

**ATTACHMENT B**

Stratigraphic Column  
CTE Center Tract  
Airport Road and Vortac Lane  
Georgetown, Texas

HYDROGEOLOGIC SUBDIVISION	FORMATION	THICKNESS (feet)	LITHOLOGY
Edwards Aquifer	Georgetown Formation	85	Marly, nodular limestone, fossiliferous

Source: Senger, Collins and Kreidler, 1990

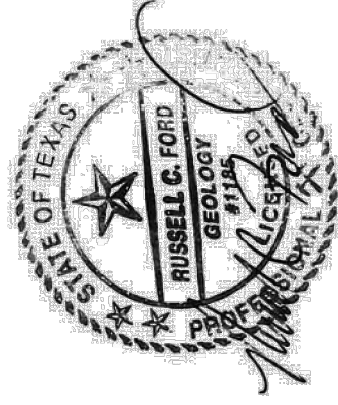

11/10/2020



## ATTACHMENT C SITE-SPECIFIC GEOLOGY

The Geologic Assessment (GA) of the CTE Center Tract was performed by Mr. Russell C. Ford, P.G., of Terracon on October 8, 2020. The site is an approximate 35.12-acre tract of undeveloped ranchland located the east side of Airport Road, east of its intersection with Vortac Lane in Georgetown, Williamson County, Texas. Exhibit 1 (attached) is a site location map depicting the site in relation to the surrounding area. The areas immediately surrounding the site are a mix of undeveloped, residential, and commercial properties. The site is characterized as gently sloping to the northeast and a small drainage swale is located in the northeastern portion of the site. Site elevation ranges from about 766 feet above mean sea level (msl) to 732 feet above msl.

The surficial geologic unit present at the site has been identified as the Georgetown Formation. Exhibit 2 (attached) is a geologic map of the site. The Georgetown Formation overlies the Edwards Formation and forms the uppermost portion of the Edwards Aquifer. The Georgetown Formation consists of an interbedded nodular, fossiliferous limestone and marl layers. The site is located entirely within the recharge zone of the Edwards Aquifer and the recharge zone boundary is located about 2.5 miles southeast of the site. Table 1 (attached) is a stratigraphic column prepared for the site. Exposure of this unit onsite is obscured by the soil cover and vegetation present. No faulting was observed on the site. The nearest mapped fault is located approximately 1.5 miles south of the site. The fault, which trends toward the northeast, is associated with the Balcones Fault zone which represents the dominant structural trend in the vicinity of the site. The completed Geologic Assessment form is attached.

No geologic features were observed on the site. Due to the lack of any significant sensitive recharge features observed on the site and the presence of a relatively impermeable soil cover present, the potential for fluid movement to the Edwards aquifer beneath the project improvement areas is considered low. No streams or springs were observed onsite. A review of the site maps contained in the City of Georgetown Ordinance 2015-14 indicated there are no known springs occupied by the Georgetown Salamander on the site and the nearest known occupied site is located approximately one mile northwest of the site (Bat Well Cave).

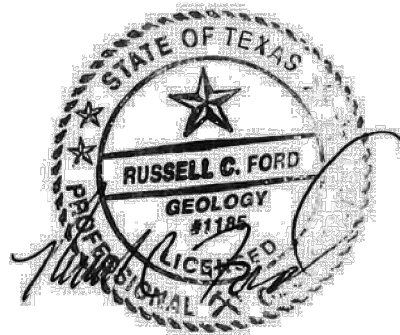

11/10/2020

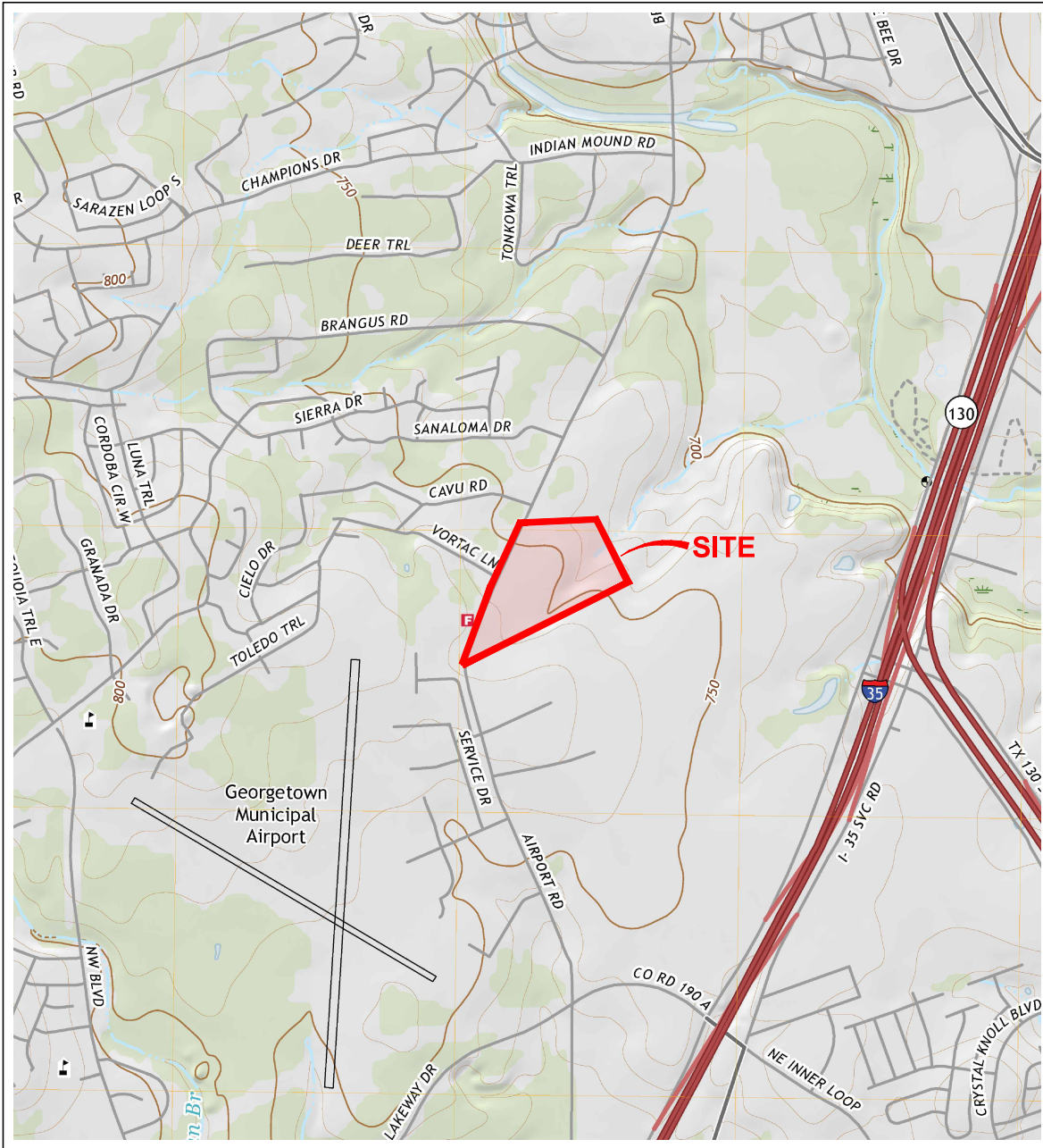

SCALE 1:24,000

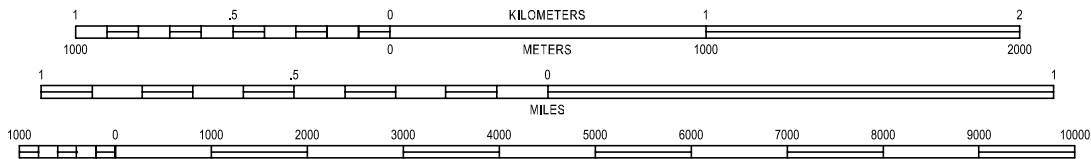

CONTOUR INTERVAL 10 FEET

NATIONAL GEODETIC VERTICAL DATUM OF 1988

**Georgetown, Texas**  
 2019  
 7.5 MINUTE SERIES (TOPOGRAPHIC)

Project Mngr:	KD
Drawn By:	ATX Drafting
Checked By:	KD
Approved By:	KD

Project No.	96207593A
Scale:	AS SHOWN
File No.	96207593A
Date:	Aug 02, 2023



**Consulting Engineers and Scientists**  
 5307 INDUSTRIAL OAKS BLVD., #160 AUSTIN, TX 78735  
 PH. (512) 442-1122 FAX (512) 442-1181

**TOPOGRAPHIC MAP**  
**CTE Center Tract**  
 Airport Road and Vortac Lane  
 Georgetown, Williamson County, Texas

EXHIBIT
1

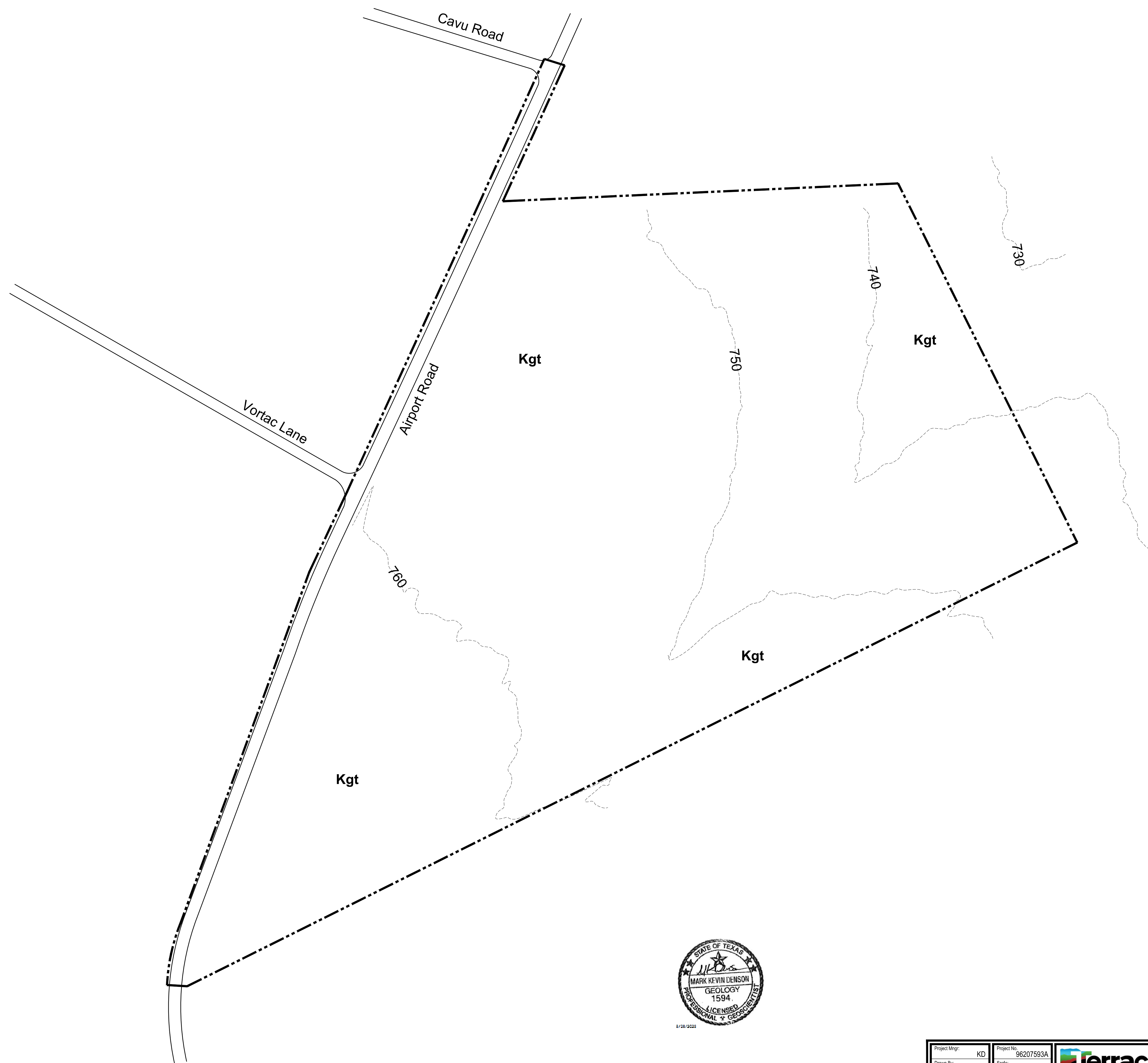

**LEGEND**

- Site Boundary
- Topographic Contours at 10' Intervals
- Kgt** Georgetown Formation

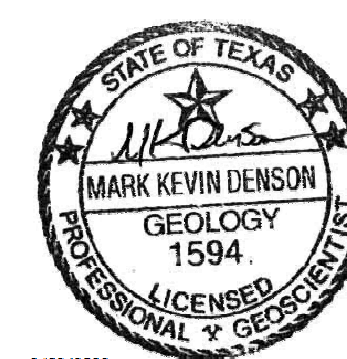

1/28/2023

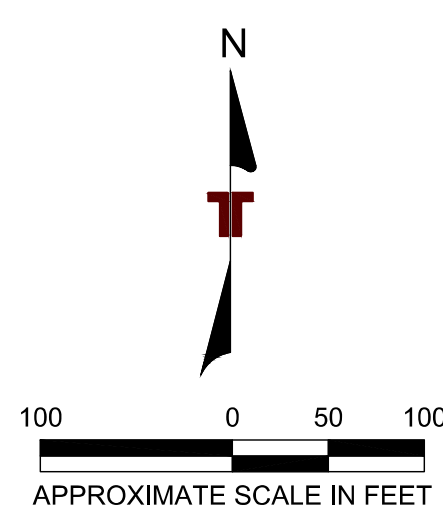

Project Mgr:	KD	Project No.:	96207593A	 Consulting Engineers and Scientists <small>5307 INDUSTRIAL OAKS BLVD. - #160 AUSTIN, TX 78735          PRT. (512) 442-1122 FAX (512) 442-1181</small>	<b>SITE GEOLOGIC MAP</b> <b>CTE Center Tract</b> Airport Road and Vortac Lane Georgetown, Williamson County, Texas	<b>EXHIBIT</b>  <b>2</b>
Drawn By:	ATX Drafting	Scale:	AS SHOWN			
Checked By:	KD	File No.:	96207593A			
Approved By:	KD	Date:	Aug 28, 2023			

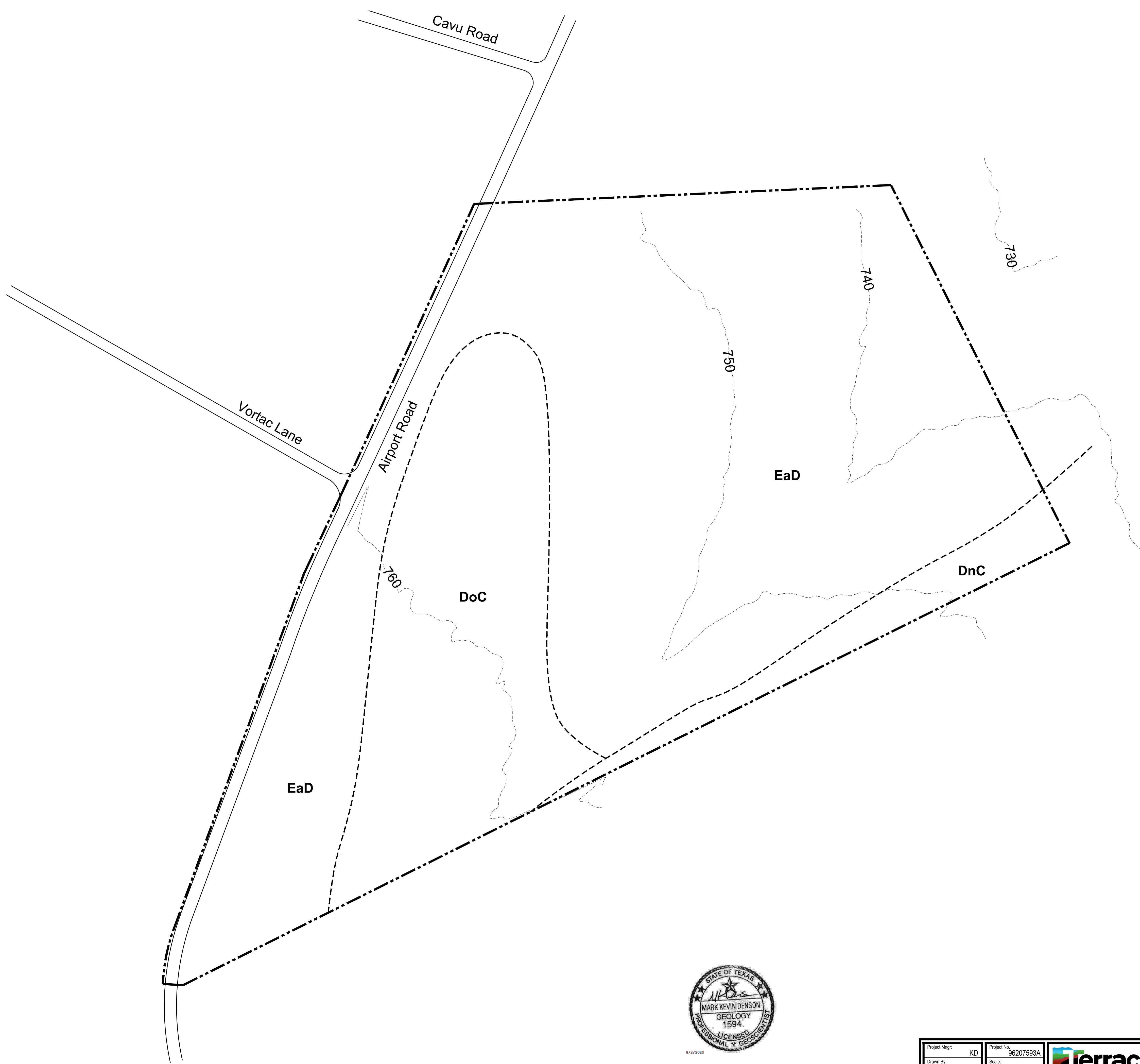

**LEGEND**

- Site Boundary
- Topographic Contours at 10' Intervals
- DnC** Denton Silty Clay  
(3%-5% slopes)
- DoC** Doss Silty Clay, Moist  
(1%-5% slopes)
- EaD** Eckrant Cobbly Clay  
(1%-8% slopes)

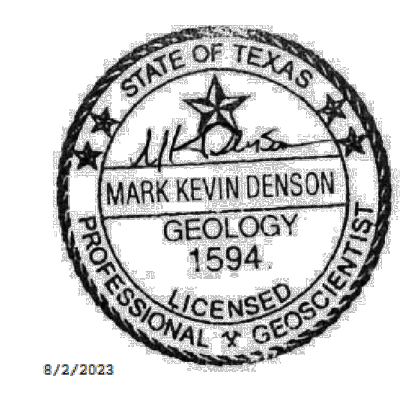
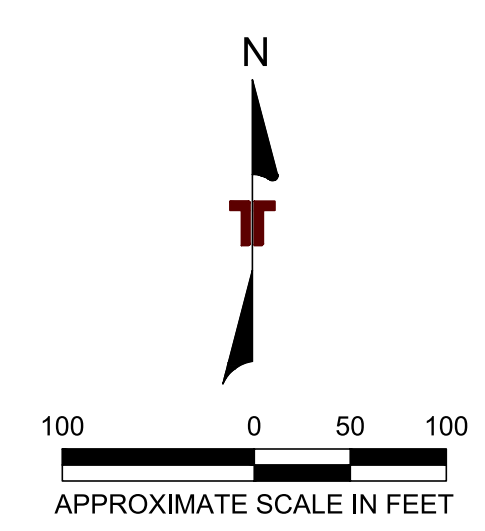

Project Mgr:	KD	Project No:	96207593A
Drawn By:	ATX Drafting	Scale:	AS SHOWN
Checked By:	KD	File No:	96207593A
Approved By:	KD	Date:	Aug 02, 2023

**Terracon**  
Consulting Engineers and Scientists  
5307 INDUSTRIAL OAKS BLVD. - #160 AUSTIN, TX 78735  
PH: (512) 442-1122 FAX: (512) 442-1161

**SITE SOILS MAP**  
**CTE Center Tract**  
Airport Road and Vortac Lane  
Georgetown, Williamson County, Texas



# Water Pollution Abatement Plan Application

Texas Commission on Environmental Quality

For Regulated Activities on the Edwards Aquifer Recharge Zone and Relating to 30 TAC §213.5(b), Effective June 1, 1999

*To ensure that the application is administratively complete, confirm that all fields in the form are complete, verify that all requested information is provided, consistently reference the same site and contact person in all forms in the application, and ensure forms are signed by the appropriate party.*

*Note: Including all the information requested in the form and attachments contributes to more streamlined technical reviews.*

## Signature

To the best of my knowledge, the responses to this form accurately reflect all information requested concerning the proposed regulated activities and methods to protect the Edwards Aquifer. This **Water Pollution Abatement Plan Application Form** is hereby submitted for TCEQ review and Executive Director approval. The form was prepared by:

Print Name of Customer/Agent: Georgetown ISD / Steger Bizzell, Bryan Moore, P.E.

Date: 7/28/2023

Signature of Customer/Agent:



Regulated Entity Name: Airport Road Improvements

## Regulated Entity Information

1. The type of project is:

- Residential: Number of Lots: \_
- Residential: Number of Living Unit Equivalents: \_\_\_\_\_
- Commercial
- Industrial
- Other: Road Construction and Expansion

2. Total site acreage (size of property): 3.46

3. Estimated projected population: 0

4. The amount and type of impervious cover expected after construction are shown below:

**Table 1 – Impervious Cover Table**

<b>Impervious Cover of Proposed Project</b>	<b>Sq. Ft.</b>	<b>Sq. Ft./Acre</b>	<b>Acres</b>
Structures/Rooftops	0.0	÷ 43,560 =	0.0
Parking	0.0	÷ 43,560 =	0.0
Other paved surfaces	95,929.67	÷ 43,560 =	2.2
<b>Total Impervious Cover</b>	<b>95,929.67</b>	<b>÷ 43,560 =</b>	<b>2.2</b>

**Total Impervious Cover 2.2 ÷ Total Acreage 3.46 X 100 = 63.65% Impervious Cover**

5.  **Attachment A - Factors Affecting Surface Water Quality.** A detailed description of all factors that could affect surface water and groundwater quality that addresses ultimate land use is attached.
6.  Only inert materials as defined by 30 TAC §330.2 will be used as fill material.

***For Road Projects Only***

**Complete questions 7 - 12 if this application is exclusively for a road project.**

7. Type of project:

- TXDOT road project.
- County road or roads built to county specifications.
- City thoroughfare or roads to be dedicated to a municipality.
- Street or road providing access to private driveways.

8. Type of pavement or road surface to be used:

- Concrete
- Asphaltic concrete pavement
- Other: \_\_\_\_\_

9. Length of Right of Way (R.O.W.): 1,991 feet.

Width of R.O.W.: 85.6 feet.

L x W = 170,429.6 Ft<sup>2</sup> ÷ 43,560 Ft<sup>2</sup>/Acre = 3.91 acres.

10. Length of pavement area: 1,991 feet.

Width of pavement area: 50 feet.

L x W = 99,550 Ft<sup>2</sup> ÷ 43,560 Ft<sup>2</sup>/Acre = 2.28 acres.

Pavement area 2.28 acres ÷ R.O.W. area 3.91 acres x 100 = 58.3% impervious cover.

11.  A rest stop will be included in this project.

A rest stop will not be included in this project.

12.  Maintenance and repair of existing roadways that do not require approval from the TCEQ Executive Director. Modifications to existing roadways such as widening roads/adding shoulders totaling more than one-half (1/2) the width of one (1) existing lane require prior approval from the TCEQ.

***Stormwater to be generated by the Proposed Project***

13.  Attachment B - Volume and Character of Stormwater. A detailed description of the volume (quantity) and character (quality) of the stormwater runoff which is expected to occur from the proposed project is attached. The estimates of stormwater runoff quality and quantity are based on the area and type of impervious cover. Include the runoff coefficient of the site for both pre-construction and post-construction conditions.

***Wastewater to be generated by the Proposed Project***

14. The character and volume of wastewater is shown below:

<u>100%</u> Domestic	Gallons/day
<u>      </u> % Industrial	<u>      </u> Gallons/day
<u>      </u> % Commingled	<u>      </u> Gallons/day
TOTAL gallons/day	

15. Wastewater will be disposed of by:

- On-Site Sewage Facility (OSSF/Septic Tank):
  - Attachment C - Suitability Letter from Authorized Agent.** An on-site sewage facility will be used to treat and dispose of the wastewater from this site. The appropriate licensing authority's (authorized agent) written approval is attached. It states that the land is suitable for the use of private sewage facilities and will meet or exceed the requirements for on-site sewage facilities as specified under 30 TAC Chapter 285 relating to On-site Sewage Facilities.
  - Each lot in this project/development is at least one (1) acre (43,560 square feet) in size. The system will be designed by a licensed professional engineer or registered sanitarian and installed by a licensed installer in compliance with 30 TAC Chapter 285.
- Sewage Collection System (Sewer Lines):
  - Private service laterals from the wastewater generating facilities will be connected to an existing SCS.
  - Private service laterals from the wastewater generating facilities will be connected to a proposed SCS.
  - The SCS was previously submitted on \_\_\_\_\_.
  - The SCS was submitted with this application.
  - The SCS will be submitted at a later date. The owner is aware that the SCS may not be installed prior to Executive Director approval.
  - The sewage collection system will convey the wastewater to the \_\_\_\_\_(name) Treatment Plant. The treatment facility is:

- Existing.
- Proposed.

16.  All private service laterals will be inspected as required in 30 TAC §213.5.

## **Site Plan Requirements**

**Items 17 – 28 must be included on the Site Plan.**

17.  The Site Plan must have a minimum scale of 1" = 400'.

Site Plan Scale: 1" = 100'.

18. 100-year floodplain boundaries:

Some part(s) of the project site is located within the 100-year floodplain. The floodplain is shown and labeled.

No part of the project site is located within the 100-year floodplain.

The 100-year floodplain boundaries are based on the following specific (including date of material) sources(s): FIRM Panels: 48491C0283F; Date: 12/19/2019

19.  The layout of the development is shown with existing and finished contours at appropriate, but not greater than ten-foot contour intervals. Lots, recreation centers, buildings, roads, open space, etc. are shown on the plan.

The layout of the development is shown with existing contours at appropriate, but not greater than ten-foot intervals. Finished topographic contours will not differ from the existing topographic configuration and are not shown. Lots, recreation centers, buildings, roads, open space, etc. are shown on the site plan.

20. All known wells (oil, water, unplugged, capped and/or abandoned, test holes, etc.):

There are \_\_\_\_\_ (#) wells present on the project site and the locations are shown and labeled. (Check all of the following that apply)

The wells are not in use and have been properly abandoned.

The wells are not in use and will be properly abandoned.

The wells are in use and comply with 16 TAC §76.

There are no wells or test holes of any kind known to exist on the project site.

21. Geologic or manmade features which are on the site:

All sensitive geologic or manmade features identified in the Geologic Assessment are shown and labeled.

No sensitive geologic or manmade features were identified in the Geologic Assessment.

**Attachment D - Exception to the Required Geologic Assessment.** A request and justification for an exception to a portion of the Geologic Assessment is attached.

22.  The drainage patterns and approximate slopes anticipated after major grading activities.

23.  Areas of soil disturbance and areas which will not be disturbed.

- 24.  Locations of major structural and nonstructural controls. These are the temporary and permanent best management practices.
- 25.  Locations where soil stabilization practices are expected to occur.
- 26.  Surface waters (including wetlands).  
 N/A
- 27.  Locations where stormwater discharges to surface water or sensitive features are to occur.  
 There will be no discharges to surface water or sensitive features.
- 28.  Legal boundaries of the site are shown.

### ***Administrative Information***

- 29.  Submit one (1) original and one (1) copy of the application, plus additional copies as needed for each affected incorporated city, groundwater conservation district, and county in which the project will be located. The TCEQ will distribute the additional copies to these jurisdictions. The copies must be submitted to the appropriate regional office.
- 30.  Any modification of this WPAP will require Executive Director approval, prior to construction, and may require submission of a revised application, with appropriate fees.

## **Attachment A – Factors Affecting Surface Water Quality**

The following factors are anticipated to adversely affect surface water and groundwater quality:

- Disturbance of vegetated areas.
- Leaking oil from parked vehicles.
- Malfunctioning wastewater collection system and spill on site.
- Loss of vegetative ground cover due to inadequate watering or mismanagement.
- Over fertilizing vegetative areas.
- The use of roads by automotive traffic and subsequent oil/grease pollutants from normal use.
- The accidental or improper discharge of the following:
  - a) Concrete
  - b) Cleaning solvents
  - c) Detergents
  - d) Petroleum based products
  - e) Paints
  - f) Paint solvents
  - g) Acids
  - h) Concrete additives

## **Attachment B – Volume and Character of Storm Water**

Existing site conditions are for paved road with no shoulders. The proposed Airport Road Improvements is composed of a drainage area which discharges to the BMPs south of the property. A summary of the drainage calculations is included in the Airport Road Improvements Construction Plans included with this submittal.

The character of the storm water generated by this project is typical of minor arterial collector road construction. The stormwater flows across the pavement, then through stormwater culverts and is directed towards the proposed Vegetative Filter Strips for treatment.

Please see attached water quality plans within the plan set.



# Temporary Stormwater Section

## Texas Commission on Environmental Quality

for Regulated Activities on the Edwards Aquifer Recharge Zone and Relating to 30 TAC §213.5(b)(4)(A), (B), (D)(I) and (G); Effective June 1, 1999

***To ensure that the application is administratively complete, confirm that all fields in the form are complete, verify that all requested information is provided, consistently reference the same site and contact person in all forms in the application, and ensure forms are signed by the appropriate party.***

***Note: Including all the information requested in the form and attachments contributes to more streamlined technical reviews.***

## Signature

To the best of my knowledge, the responses to this form accurately reflect all information requested concerning the proposed regulated activities and methods to protect the Edwards Aquifer. This **Temporary Stormwater Section** is hereby submitted for TCEQ review and executive director approval. The application was prepared by:

Print Name of Customer/Agent: Georgetown ISD / Steger Bizzell, Bryan Moore, P.E.

Date: 7/28/2023

Signature of Customer/Agent:



Regulated Entity Name: Airport Road Improvements

## Project Information

### Potential Sources of Contamination

*Examples: Fuel storage and use, chemical storage and use, use of asphaltic products, construction vehicles tracking onto public roads, and existing solid waste.*

1. Fuels for construction equipment and hazardous substances which will be used during construction:

The following fuels and/or hazardous substances will be stored on the site: \_\_\_\_\_

These fuels and/or hazardous substances will be stored in:

Aboveground storage tanks with a cumulative storage capacity of less than 250 gallons will be stored on the site for less than one (1) year.

- Aboveground storage tanks with a cumulative storage capacity between 250 gallons and 499 gallons will be stored on the site for less than one (1) year.
- Aboveground storage tanks with a cumulative storage capacity of 500 gallons or more will be stored on the site. An Aboveground Storage Tank Facility Plan application must be submitted to the appropriate regional office of the TCEQ prior to moving the tanks onto the project.
- Fuels and hazardous substances will not be stored on the site.
- 2.  **Attachment A - Spill Response Actions.** A site specific description of the measures to be taken to contain any spill of hydrocarbons or hazardous substances is attached.
- 3.  Temporary aboveground storage tank systems of 250 gallons or more cumulative storage capacity must be located a minimum horizontal distance of 150 feet from any domestic, industrial, irrigation, or public water supply well, or other sensitive feature.
- 4.  **Attachment B - Potential Sources of Contamination.** A description of any activities or processes which may be a potential source of contamination affecting surface water quality is attached.

### ***Sequence of Construction***

- 5.  **Attachment C - Sequence of Major Activities.** A description of the sequence of major activities which will disturb soils for major portions of the site (grubbing, excavation, grading, utilities, and infrastructure installation) is attached.
  - For each activity described, an estimate (in acres) of the total area of the site to be disturbed by each activity is given.
  - For each activity described, include a description of appropriate temporary control measures and the general timing (or sequence) during the construction process that the measures will be implemented.
- 6.  Name the receiving water(s) at or near the site which will be disturbed or which will receive discharges from disturbed areas of the project: BERRY CREEK

### ***Temporary Best Management Practices (TBMPs)***

*Erosion control examples: tree protection, interceptor swales, level spreaders, outlet stabilization, blankets or matting, mulch, and sod. Sediment control examples: stabilized construction exit, silt fence, filter dikes, rock berms, buffer strips, sediment traps, and sediment basins. Please refer to the Technical Guidance Manual for guidelines and specifications. All structural BMPs must be shown on the site plan.*

- 7.  **Attachment D – Temporary Best Management Practices and Measures.** TBMPs and measures will prevent pollution of surface water, groundwater, and stormwater. The construction-phase BMPs for erosion and sediment controls have been designed to retain sediment on site to the extent practicable. The following information is attached:

- A description of how BMPs and measures will prevent pollution of surface water, groundwater or stormwater that originates upgradient from the site and flows across the site.
  - A description of how BMPs and measures will prevent pollution of surface water or groundwater that originates on-site or flows off site, including pollution caused by contaminated stormwater runoff from the site.
  - A description of how BMPs and measures will prevent pollutants from entering surface streams, sensitive features, or the aquifer.
  - A description of how, to the maximum extent practicable, BMPs and measures will maintain flow to naturally-occurring sensitive features identified in either the geologic assessment, TCEQ inspections, or during excavation, blasting, or construction.
8.  The temporary sealing of a naturally-occurring sensitive feature which accepts recharge to the Edwards Aquifer as a temporary pollution abatement measure during active construction should be avoided.
- Attachment E - Request to Temporarily Seal a Feature.** A request to temporarily seal a feature is attached. The request includes justification as to why no reasonable and practicable alternative exists for each feature.
  - There will be no temporary sealing of naturally-occurring sensitive features on the site.
9.  **Attachment F - Structural Practices.** A description of the structural practices that will be used to divert flows away from exposed soils, to store flows, or to otherwise limit runoff discharge of pollutants from exposed areas of the site is attached. Placement of structural practices in floodplains has been avoided.
10.  **Attachment G - Drainage Area Map.** A drainage area map supporting the following requirements is attached:
- For areas that will have more than 10 acres within a common drainage area disturbed at one time, a sediment basin will be provided.
  - For areas that will have more than 10 acres within a common drainage area disturbed at one time, a smaller sediment basin and/or sediment trap(s) will be used.
  - For areas that will have more than 10 acres within a common drainage area disturbed at one time, a sediment basin or other equivalent controls are not attainable, but other TBMPs and measures will be used in combination to protect down slope and side slope boundaries of the construction area.
  - There are no areas greater than 10 acres within a common drainage area that will be disturbed at one time. A smaller sediment basin and/or sediment trap(s) will be used in combination with other erosion and sediment controls within each disturbed drainage area.
  - There are no areas greater than 10 acres within a common drainage area that will be disturbed at one time. Erosion and sediment controls other than sediment basins or sediment traps within each disturbed drainage area will be used.

11.  **Attachment H - Temporary Sediment Pond(s) Plans and Calculations.** Temporary sediment pond or basin construction plans and design calculations for a proposed temporary BMP or measure have been prepared by or under the direct supervision of a Texas Licensed Professional Engineer. All construction plans and design information must be signed, sealed, and dated by the Texas Licensed Professional Engineer. Construction plans for the proposed temporary BMPs and measures are attached.
- N/A
12.  **Attachment I - Inspection and Maintenance for BMPs.** A plan for the inspection of each temporary BMP(s) and measure(s) and for their timely maintenance, repairs, and, if necessary, retrofit is attached. A description of the documentation procedures, recordkeeping practices, and inspection frequency are included in the plan and are specific to the site and/or BMP.
13.  All control measures must be properly selected, installed, and maintained in accordance with the manufacturer's specifications and good engineering practices. If periodic inspections by the applicant or the executive director, or other information indicate a control has been used inappropriately, or incorrectly, the applicant must replace or modify the control for site situations.
14.  If sediment escapes the construction site, off-site accumulations of sediment must be removed at a frequency sufficient to minimize offsite impacts to water quality (e.g., fugitive sediment in street being washed into surface streams or sensitive features by the next rain).
15.  Sediment must be removed from sediment traps or sedimentation ponds not later than when design capacity has been reduced by 50%. A permanent stake will be provided that can indicate when the sediment occupies 50% of the basin volume.
16.  Litter, construction debris, and construction chemicals exposed to stormwater shall be prevented from becoming a pollutant source for stormwater discharges (e.g., screening outfalls, picked up daily).

## ***Soil Stabilization Practices***

*Examples: establishment of temporary vegetation, establishment of permanent vegetation, mulching, geotextiles, sod stabilization, vegetative buffer strips, protection of trees, or preservation of mature vegetation.*

17.  **Attachment J - Schedule of Interim and Permanent Soil Stabilization Practices.** A schedule of the interim and permanent soil stabilization practices for the site is attached.
18.  Records must be kept at the site of the dates when major grading activities occur, the dates when construction activities temporarily or permanently cease on a portion of the site, and the dates when stabilization measures are initiated.
19.  Stabilization practices must be initiated as soon as practicable where construction activities have temporarily or permanently ceased.

## ***Administrative Information***

20.  All structural controls will be inspected and maintained according to the submitted and approved operation and maintenance plan for the project.
21.  If any geologic or manmade features, such as caves, faults, sinkholes, etc., are discovered, all regulated activities near the feature will be immediately suspended. The appropriate TCEQ Regional Office shall be immediately notified. Regulated activities must cease and not continue until the TCEQ has reviewed and approved the methods proposed to protect the aquifer from any adverse impacts.
22.  Silt fences, diversion berms, and other temporary erosion and sediment controls will be constructed and maintained as appropriate to prevent pollutants from entering sensitive features discovered during construction.

## **Attachment A – Spill Response Actions**

Because fuels and hazardous substances will be provided by an off-site facility, no on-site containment procedures are provided for in this WPAP.

The objective of this section is to describe measures to prevent or reduce the discharge of pollutants to drainage systems or watercourses from leaks and spills by reducing the chance for spills, stopping the source of spills, containing and cleaning up spills, properly disposing of spill materials, and training employees. The following steps will help reduce the stormwater impacts of leaks and spills:

### ***Education***

1. Be aware that different materials pollute in different amounts. Make sure that each employee knows what a “significant spill” is for each material they use, and what is the appropriate response for “significant” and “insignificant” spills. Employees should also be aware of when spill must be reported to the TCEQ. Information available in 30 TAC 327.4 and 40 CFR 302.4.
2. Educate employees and subcontractors on potential dangers to humans and the environment from spills and leaks.
3. Hold regular meetings to discuss and reinforce appropriate disposal procedures (incorporate into regular safety meetings).
4. Establish a continuing education program to indoctrinate new employees.
5. Have contractor’s superintendent or representative oversee and enforce proper spill prevention and control measures.

### ***General Measures***

1. To the extent that the work can be accomplished safely, spills of oil, petroleum products, and substances listed under 40 CFR parts 110,117, and 302, and sanitary and septic wastes should be contained and cleaned up immediately.
2. Store hazardous materials and wastes in covered containers and protect from vandalism.
3. Place a stockpile of spill cleanup materials where it will be readily accessible.
4. Train employees in spill prevention and cleanup.
5. Designate responsible individuals to oversee and enforce control measures.
6. Spills should be covered and protected from stormwater run-on during rainfall to the extent that it doesn’t compromise clean-up activities.
7. Do not bury or wash spills with water.
8. Store and dispose of used clean up materials, contaminated materials, and recovered spill material that is no longer suitable for the intended purpose in conformance with the provisions in applicable BMPs.
9. Do not allow water used for cleaning and decontamination to enter storm drains or watercourses. Collect and dispose of contaminated water in accordance with applicable regulations.
10. Contain water overflow or minor water spillage and do not allow it to discharge into drainage facilities or watercourses.

11. Place Material Safety Data Sheets (MSDS), as well as proper storage, cleanup, and spill reporting instructions for hazardous materials stored or used on the project site in an open, conspicuous, and accessible location.
12. Keep waste storage areas clean, well-organized, and equipped with ample cleanup supplies as appropriate for the materials being stored. Perimeter controls, containment structures, covers, and liners should be repaired or replaced as needed to maintain proper function.

### **Cleanup**

1. Clean up leaks and spills immediately.
2. Use a rag for small spills on paved surfaces, a damp mop for general cleanup, and absorbent material for larger spills. If the spilled material is hazardous, then the used cleanup materials are also hazardous and must be disposed of as hazardous waste.
3. Never hose down or bury dry material spills. Clean up as much of the material as possible and dispose of properly. See the waste management BMPs in this section for specific information.

### **Minor Spills**

1. Minor spills typically involve small quantities of oil, gasoline, paint, etc. which can be controlled by the first responder at the discovery of the spill.
2. Use absorbent materials on small spills rather than hosing down or burying the spill.
3. Absorbent materials should be promptly removed and disposed of properly.
4. Follow the practice below for a minor spill:
5. Contain the spread of the spill.
6. Recover spilled materials.
7. Clean the contaminated area and properly dispose of contaminated materials.

### **Semi-Significant Spills**

Semi-significant spills still can be controlled by the first responder along with the aid of other personnel such as laborers and the foreman, etc. This response may require the cessation of all other activities.

Spills should be cleaned up immediately:

1. Contain spread of the spill.
2. Notify the project foreman immediately.
3. If the spill occurs on paved or impermeable surfaces, clean up using "dry" methods (absorbent materials, cat litter and/or rags). Contain the spill by encircling with absorbent materials and do not let the spill spread widely.
4. If the spill occurs in dirt areas, immediately contain the spill by constructing an earthen dike. Dig up and properly dispose of contaminated soil.
5. If the spill occurs during rain, cover spill with tarps or other material to prevent contaminating runoff.

### **Significant/Hazardous Spills**

For significant or hazardous spills that are in reportable quantities:

1. Notify the TCEQ by telephone as soon as possible and within 24 hours at 512-339-2929 (Austin) or 210-490-3096 (San Antonio) between 8 AM and 5 PM. After hours, contact the

Environmental Release Hotline at 1-800-832-8224. It is the contractor's responsibility to have all emergency phone numbers at the construction site.

2. For spills of federal reportable quantities, in conformance with the requirements in 40 CFR parts 110, 119, and 302, the contractor should notify the National Response Center at (800) 424-8802.
3. Notification should first be made by telephone and followed up with a written report.
4. The services of a spills contractor or a Haz-Mat team should be obtained immediately. Construction personnel should not attempt to clean up until the appropriate and qualified staffs have arrived at the job site.
5. Other agencies which may need to be consulted include, but are not limited to, the City Police Department, County Sheriff Office, Fire Departments, etc.

More information on spill rules and appropriate responses is available on the TCEQ website at: <http://www.tceq.texas.gov/response/>

### ***Vehicle and Equipment Maintenance***

1. If maintenance must occur onsite, use a designated area and a secondary containment, located away from drainage courses, to prevent the run-on of stormwater and the runoff of spills.
2. Regularly inspect onsite vehicles and equipment for leaks and repair immediately.
3. Check incoming vehicles and equipment (including delivery trucks, and employee and subcontractor vehicles) for leaking oil and fluids. Do not allow leaking vehicles or equipment onsite.
4. Always use secondary containment, such as a drain pan or drop cloth, to catch spills or leaks when removing or changing fluids.
5. Place drip pans or absorbent materials under paving equipment when not in use.
6. Use absorbent materials on small spills rather than hosing down or burying the spill. Remove the absorbent materials promptly and dispose of properly.
7. Promptly transfer used fluids to the proper waste or recycling drums. Don't leave full drip pans or other open containers lying around.
8. Oil filters disposed of in trashcans or dumpsters can leak oil and pollute stormwater. Place the oil filter in a funnel over a waste oil-recycling drum to drain excess oil before disposal. Oil filters can also be recycled. Ask the oil supplier or recycler about recycling oil filters.
9. Store cracked batteries in a non-leaking secondary container. Do this with all cracked batteries even if you think all the acid has drained out. If you drop a battery, treat it as if it is cracked. Put it into the containment area until you are sure it is not leaking.

### ***Vehicle and Equipment Fueling***

1. If fueling must occur on site, use designated areas, located away from drainage courses, to prevent the run-on of stormwater and the runoff of spills.
2. Discourage "topping off" of fuel tanks.
3. Always use secondary containment, such as a drain pan, when fueling to catch spills/ leaks.

If a spill should occur, the person responsible for the spill should contact the TCEQ at (512) 339-2929 or call 911. Soil contaminated by spills that occur on-site will be removed and disposed at an approved disposal site.



## **Attachment B – Potential Sources of Contamination**

- Hydraulic and diesel
- Portable toilet systems (Sanitary Waste)
- Trash from construction workers
- Paints, Paint Solvents, glues, concrete and other building materials
- Plant fertilizers and Pesticides
- Inadequate maintenance of temporary water pollution abatement measures
- Stock piles or spoils of materials

### Attachment C – Sequence of Major Activities

The following sequence of activities is suggested. The actual sequence may vary slightly depending on the contractor or weather conditions.

1. Construction activities will commence with the installation of the required erosion and sedimentation control measures. **Silt fence is the control measure.**
2. Excavation will take place where the roads and culverts will be situated. Spoils of this material may be placed at a location on the project site as directed by the contractor or hauled off-site. These spoils and any other loose granular material will be enclosed by a silt fence.
3. The installation of the BMPs and storm sewer will disturb a portion of the site. Proposed utility improvements include the construction of BMPs and storm sewer culverts and connections. **Silt fence is the control measure.**
4. Grading on the site will consist of the placement and compaction of base or select fill material under and/or around the roads and culverts and excavation and fill for the proposed roads and culverts. **Silt fence is the control measure.**
5. Paving of the site will consist of the roads and driveways being concrete. **Concrete washouts will be used as the control measures.**
6. After the roads and driveways are installed, finish grading around the site will be completed.
7. Subsequent to the construction of the roads, driveways, etc. disturbed areas will be hydro-mulched or seeded.
8. Once vegetation is established on the site, Temporary BMPs will be removed as allowed by the engineer.

## Attachment D – Temporary Best Management Practices and Measures

The following sequence of activities is suggested. The sequence of construction will take place in one phase. The actual sequence may vary slightly depending on the contractor or weather conditions.

1. Construction activities will commence with the installation of the required **silt fence, contractor staging and storage area, and a concrete washout area as erosion and sedimentation control measures.**
2. Excavation will take place where the roads and culverts will be situated. Spoils of this material may be placed at a location on the project site as directed by the contractor or hauled off-site. These spoils and any other loose granular material will be enclosed by a silt fence. **Silt fence and rock berm will be utilized as the control measures.**
3. Grading on the site will consist of the placement and compaction of base or select fill material under and/or around the roads and culverts and excavation and fill for the proposed ponds, roads and culverts. **Silt fence will be utilized as the control measures.**
4. The installation of the utilities and storm sewer will disturb a portion of the site. Proposed utility improvements include the construction of storm sewer culverts and connections. **Silt fence and rock berm will be utilized as the control measures.**
5. Subsequent to the construction of the roads, driveways, etc. disturbed areas will be hydro-mulched or seeded. **Silt fence and rock berm will be utilized as the control measures.**
6. Once vegetation is established on the site, Temporary BMPs will be removed as allowed by the engineer.

All surface runoff originating up-gradient or on site will be contained within the proposed silt fence and rock berm. The silt fence and rock berm will trap most pollutants and prevent them from entering off-site surface streams, sensitive features or the aquifer.

**Attachment E – Request to Temporarily Seal a Feature**

There will be no temporary sealing of naturally-occurring sensitive features on the site.

## **Attachment F – Structural Practices**

No structural practices will be utilized to divert flows away from exposed soils or to store flows. Silt fences and construction entrances will be used to limit the runoff discharge of sediments from exposed areas on the site during construction. Drainage off the site is typically in a sheet flow or shallow concentrated flow condition.

### **Attachment G – Drainage Area Map**

See the Attached Airport Road Improvements construction plans for existing and proposed drainage area maps.

## **Attachment I – Inspection and Maintenance for BMPs**

### *Silt Fence*

1. Inspect all fences weekly and after any rainfall.
2. Remove sediment when buildup reaches 6 inches, or install a second line of fencing parallel to the old fence.
3. Replace any torn fabric or install a second line of fencing parallel to the torn section.
4. Replace or repair any sections crushed or collapsed in the course of construction activity. If a section of fence is obstructing vehicular access, consider relocating it to a spot where it will provide equal protection, but will not obstruct vehicles. A triangular filter dike may be preferable to a silt fence at common vehicle access points.
5. When construction is complete, the sediment should be disposed of in a manner that will not cause additional siltation and the prior location of the silt fence should be revegetated. The fence itself should be disposed of in an approved landfill.

### *Concrete Washout*

1. Inspection should be made weekly and after each rainfall by the responsible party.
2. Remove sediment and other debris when buildup reaches 6 inches and dispose of the accumulated silt in an approved manner that will not cause any additional siltation.
3. The berm/temporary pit should be reshaped as needed during inspection.
4. The berm/temporary pit should be replaced when the structure ceases to function as intended due to silt accumulation among the rocks, washout, construction traffic damage, etc.
5. The washout should be left in place until construction has been completed.
6. When construction is complete, the sediment should be disposed of in a manner that will not cause additional siltation and the prior location of the Concrete Washout should be revegetated.
7. The concrete from the washout should be removed from the site in an appropriate manner.

### *Rock Berm*

1. Inspection should be made weekly and after each rainfall by the responsible party. For installations in streambeds, additional daily inspections should be made.
2. Remove sediment and other debris when buildup reaches 6 inches and dispose of the accumulated silt in an approved manner that will not cause any additional siltation.
3. Repair any loose wire sheathing.
4. The berm should be reshaped as needed during inspection.
5. The berm should be replaced when the structure ceases to function as intended due to silt accumulation among the rocks, washout, construction traffic damage, etc.
6. The rock berm should be left in place until all upstream areas are stabilized and accumulated silt removed.

### *Temporary Construction Entrance/Exit*

1. The entrance should be maintained in a condition, which will prevent tracking or flowing of sediment onto public rights-of-way. This may require periodic top dressing with additional stone as conditions demand and repair and/or cleanout of any measures used to trap sediment.
2. All sediment spilled, dropped, washed or tracked onto public rights-of-way should be removed immediately by contractor.
3. When necessary, wheels should be cleaned to remove sediment prior to entrance onto public right-of-way.
4. When washing is required, it should be done on an area stabilized with crushed stone that drains into an approved sediment trap or sediment basin.
5. All sediment should be prevented from entering any storm drain, ditch or water course by using approved methods.

### *Inlet Protection*

1. Inspection should be made weekly and after each rainfall. Check inlet protection for damage. Repair should be made promptly as needed by the contractor
2. Trash and other debris should be removed after each rainfall.
3. Accumulated silt should be removed.
4. The removed sediment should be stockpiled or redistributed in areas that are protected from erosion.
5. When construction is complete, the sediment should be disposed of in a manner that will not cause additional siltation.

The following sample forms should be utilized to document the inspection and maintenance of the proposed temporary BMPs as described above. This form shall be kept on site with the WPAP until the project is completed. A report documenting the Temporary BMPs maintenance activities, sediment removal and modifications to the sedimentation and erosion controls is required.











## **Attachment J – Schedule of Interim and Permanent Soil Stabilization Practices**

Vehicular traffic should be limited to areas of the project site where construction will take place. The contractor should endeavor to preserve existing vegetation as much as practicable to reduce erosion and lower the cost associated with stabilization. **Records must be kept at the site of the dates when major grading activities occur, the dates when construction activities temporarily or permanently cease on a portion of the site, and the dates when stabilization measures are initiated.**

All disturbed areas shall be stabilized as described below.

Except as provided for below, stabilization measures shall be initiated as soon as practicable in portions of the site where construction activities have temporarily or permanently ceased, but in no case more than 14 days after the construction activity in that portion of the site has temporarily or permanently ceased.

- A. Where the initiation of stabilization measures by the 14<sup>th</sup> day after construction activity temporarily or permanently ceases is precluded by snow cover or frozen ground conditions, stabilization measures shall be initiated as soon as practicable.
- B. Where construction activity on a portion of the site has temporarily ceased, and earth-disturbing activities will be resumed with 21 days, temporary stabilization measures do not have to be initiated on that portion of the site.
- C. In areas experiencing drought, where the initiation of stabilization measures by the 14<sup>th</sup> day after construction activity has temporarily or permanently ceased is precluded by seasonal arid conditions, stabilization measures shall be initiated as soon as practicable.

Stabilization measures as described as follows:

All disturbed grass areas should be planted in drought resistant species normally grown as permanent lawns, such as Zoysia, Bermuda and Buffalo. Grass areas may be sodded, plugged, sprigged or seeded except that solid sod shall be used in swales or other areas subject to erosion. All planted areas shall be provided with a readily available water supply and watered as necessary to ensure continuous healthy growth and development. Maintenance shall include the replacement of all dead plant material if that material was used to meet the requirements of this section.

# Permanent Stormwater Section

## Texas Commission on Environmental Quality

for Regulated Activities on the Edwards Aquifer Recharge Zone and Relating to 30 TAC §213.5(b)(4)(C), (D)(li), (E), and (5), Effective June 1, 1999

***To ensure that the application is administratively complete, confirm that all fields in the form are complete, verify that all requested information is provided, consistently reference the same site and contact person in all forms in the application, and ensure forms are signed by the appropriate party.***

***Note: Including all the information requested in the form and attachments contributes to more streamlined technical reviews.***

## Signature

To the best of my knowledge, the responses to this form accurately reflect all information requested concerning the proposed regulated activities and methods to protect the Edwards Aquifer. This **Permanent Stormwater Section** is hereby submitted for TCEQ review and executive director approval. The application was prepared by:

Print Name of Customer/Agent: Georgetown ISD / Steger Bizzell, Bryan Moore, P.E.

Date: 7/28/2023

Signature of Customer/Agent:



Regulated Entity Name: Airport Road Improvements

## Permanent Best Management Practices (BMPs)

***Permanent best management practices and measures that will be used during and after construction is completed.***

1.  Permanent BMPs and measures must be implemented to control the discharge of pollution from regulated activities after the completion of construction.  
 N/A
2.  These practices and measures have been designed, and will be constructed, operated, and maintained to insure that 80% of the incremental increase in the annual mass loading of total suspended solids (TSS) from the site caused by the regulated activity is removed. These quantities have been calculated in accordance with technical guidance prepared or accepted by the executive director.

The TCEQ Technical Guidance Manual (TGM) was used to design permanent BMPs and measures for this site.

A technical guidance other than the TCEQ TGM was used to design permanent BMPs and measures for this site. The complete citation for the technical guidance that was used is: \_\_\_\_\_

N/A

3.  Owners must insure that permanent BMPs and measures are constructed and function as designed. A Texas Licensed Professional Engineer must certify in writing that the permanent BMPs or measures were constructed as designed. The certification letter must be submitted to the appropriate regional office within 30 days of site completion.

N/A

4. Where a site is used for low density single-family residential development and has 20 % or less impervious cover, other permanent BMPs are not required. This exemption from permanent BMPs must be recorded in the county deed records, with a notice that if the percent impervious cover increases above 20% or land use changes, the exemption for the whole site as described in the property boundaries required by 30 TAC §213.4(g) (relating to Application Processing and Approval), may no longer apply and the property owner must notify the appropriate regional office of these changes.

The site will be used for low density single-family residential development and has 20% or less impervious cover.

The site will be used for low density single-family residential development but has more than 20% impervious cover.

The site will not be used for low density single-family residential development.

5. The executive director may waive the requirement for other permanent BMPs for multi-family residential developments, schools, or small business sites where 20% or less impervious cover is used at the site. This exemption from permanent BMPs must be recorded in the county deed records, with a notice that if the percent impervious cover increases above 20% or land use changes, the exemption for the whole site as described in the property boundaries required by 30 TAC §213.4(g) (relating to Application Processing and Approval), may no longer apply and the property owner must notify the appropriate regional office of these changes.

**Attachment A - 20% or Less Impervious Cover Waiver.** The site will be used for multi-family residential developments, schools, or small business sites and has 20% or less impervious cover. A request to waive the requirements for other permanent BMPs and measures is attached.

The site will be used for multi-family residential developments, schools, or small business sites but has more than 20% impervious cover.

The site will not be used for multi-family residential developments, schools, or small business sites.

6.  **Attachment B - BMPs for Upgradient Stormwater.**

- A description of the BMPs and measures that will be used to prevent pollution of surface water, groundwater, or stormwater that originates upgradient from the site and flows across the site is attached.
- No surface water, groundwater or stormwater originates upgradient from the site and flows across the site, and an explanation is attached.
- Permanent BMPs or measures are not required to prevent pollution of surface water, groundwater, or stormwater that originates upgradient from the site and flows across the site, and an explanation is attached.
7.  **Attachment C - BMPs for On-site Stormwater.**
- A description of the BMPs and measures that will be used to prevent pollution of surface water or groundwater that originates on-site or flows off the site, including pollution caused by contaminated stormwater runoff from the site is attached.
- Permanent BMPs or measures are not required to prevent pollution of surface water or groundwater that originates on-site or flows off the site, including pollution caused by contaminated stormwater runoff, and an explanation is attached.
8.  **Attachment D - BMPs for Surface Streams.** A description of the BMPs and measures that prevent pollutants from entering surface streams, sensitive features, or the aquifer is attached. Each feature identified in the Geologic Assessment as sensitive has been addressed.
- N/A
9.  The applicant understands that to the extent practicable, BMPs and measures must maintain flow to naturally occurring sensitive features identified in either the geologic assessment, executive director review, or during excavation, blasting, or construction.
- The permanent sealing of or diversion of flow from a naturally-occurring sensitive feature that accepts recharge to the Edwards Aquifer as a permanent pollution abatement measure has not been proposed.
- Attachment E - Request to Seal Features.** A request to seal a naturally-occurring sensitive feature, that includes, for each feature, a justification as to why no reasonable and practicable alternative exists, is attached.
10.  **Attachment F - Construction Plans.** All construction plans and design calculations for the proposed permanent BMP(s) and measures have been prepared by or under the direct supervision of a Texas Licensed Professional Engineer, and are signed, sealed, and dated. The plans are attached and, if applicable include:
- Design calculations (TSS removal calculations)
- TCEQ construction notes
- All geologic features
- All proposed structural BMP(s) plans and specifications
- N/A



11.  **Attachment G - Inspection, Maintenance, Repair and Retrofit Plan.** A plan for the inspection, maintenance, repairs, and, if necessary, retrofit of the permanent BMPs and measures is attached. The plan includes all of the following:
- Prepared and certified by the engineer designing the permanent BMPs and measures
  - Signed by the owner or responsible party
  - Procedures for documenting inspections, maintenance, repairs, and, if necessary retrofit
  - A discussion of record keeping procedures
- N/A
12.  **Attachment H - Pilot-Scale Field Testing Plan.** Pilot studies for BMPs that are not recognized by the Executive Director require prior approval from the TCEQ. A plan for pilot-scale field testing is attached.
- N/A
13.  **Attachment I -Measures for Minimizing Surface Stream Contamination.** A description of the measures that will be used to avoid or minimize surface stream contamination and changes in the way in which water enters a stream as a result of the construction and development is attached. The measures address increased stream flashing, the creation of stronger flows and in-stream velocities, and other in-stream effects caused by the regulated activity, which increase erosion that results in water quality degradation.
- N/A

### ***Responsibility for Maintenance of Permanent BMP(s)***

#### ***Responsibility for maintenance of best management practices and measures after construction is complete.***

14.  The applicant is responsible for maintaining the permanent BMPs after construction until such time as the maintenance obligation is either assumed in writing by another entity having ownership or control of the property (such as without limitation, an owner's association, a new property owner or lessee, a district, or municipality) or the ownership of the property is transferred to the entity. Such entity shall then be responsible for maintenance until another entity assumes such obligations in writing or ownership is transferred.
- N/A
15.  A copy of the transfer of responsibility must be filed with the executive director at the appropriate regional office within 30 days of the transfer if the site is for use as a multiple single-family residential development, a multi-family residential development, or a non-residential development such as commercial, industrial, institutional, schools, and other sites where regulated activities occur.
- N/A

**Attachment B – BMPs for Upgradient Stormwater**

No upgradient runoff will enter this phase of the site. No additional BMPs are proposed to treat upstream offsite runoff.

### **Attachment C – BMPs for On-site Stormwater**

The use of vegetative filter strips will be used in the development of Airport Road Improvements to treat the on-site stormwater for a total site removal of 85 percent.

Calculations to determine the pollutant load and sizing for each BMP are attached directly behind this sheet.

Additional information is provided for cells with a red triangle in the upper right corner. Place the cursor over the cell.  
 Text shown in blue indicate location of instructions in the Technical Guidance Manual - RG-348.

Characters shown in red are data entry fields.

Characters shown in black (Bold) are calculated fields. Changes to these fields will remove the equations used in the spreadsheet.

**1. The Required Load Reduction for the total project:**

Calculations from RG-348

Pages 3-27 to 3-30

Page 3-29 Equation 3.3:  $L_M = 28.9(A_N \times P)$

where:  $L_{M \text{ TOTAL PROJECT}}$  = Required TSS removal resulting from the proposed development = 85% of increased load  
 $A_N$  = Net increase in impervious area for the project  
 $P$  = Average annual precipitation, inches

Site Data: Determine Required Load Removal Based on the Entire Project

County =	<b>Williamson</b>	
Total project area included in plan *	<b>2.83</b>	acres
Predevelopment impervious area within the limits of the plan *	<b>1.01</b>	acres
Total post-development impervious area within the limits of the plan *	<b>2.20</b>	acres
Total post-development impervious cover fraction *	<b>0.78</b>	
P =	<b>32</b>	inches

$L_{M \text{ TOTAL PROJECT}}$  = **1101** lbs.

\* The values entered in these fields should be for the total project area.

Number of drainage basins / outfalls areas leaving the plan area = **1**

**2. Drainage Basin Parameters (This information should be provided for each basin):**

Drainage Basin/Outfall Area No. =	<b>1</b>	
Total drainage basin/outfall area =	<b>2.83</b>	acres
Predevelopment impervious area within drainage basin/outfall area =	<b>1.01</b>	acres
Post-development impervious area within drainage basin/outfall area =	<b>2.20</b>	acres
Post-development impervious fraction within drainage basin/outfall area =	<b>0.78</b>	
$L_{M \text{ THIS BASIN}}$ =	<b>1101</b>	lbs.

**3. Indicate the proposed BMP Code for this basin.**

Proposed BMP = **Vegetated Filter Strips**  
 Removal efficiency = **85** percent

- Aqualogic Cartridge Filter
- Bioretention
- Batch Detention Basin
- BaySeparator
- Contech StormFilter
- Constructed Wetland
- Extended Detention
- Grassy Swale
- Retention / Irrigation
- Sand Filter
- Stormceptor
- Vegetated Filter Strips
- Vortechs
- Wet Basin
- Wet Vault

**4. Calculate Maximum TSS Load Removed ( $L_R$ ) for this Drainage Basin by the selected BMP Type.**

RG-348 Page 3-33 Equation 3.7:  $L_R = (\text{BMP efficiency}) \times P \times (A_i \times 34.6 + A_p \times 0.54)$

where:  $A_C$  = Total On-Site drainage area in the BMP catchment area  
 $A_i$  = Impervious area proposed in the BMP catchment area  
 $A_p$  = Pervious area remaining in the BMP catchment area  
 $L_R$  = TSS Load removed from this catchment area by the proposed BMP

$A_C$ =	<b>2.83</b>	acres
$A_i$ =	<b>2.20</b>	acres
$A_p$ =	<b>0.63</b>	acres
$L_R$ =	<b>2080</b>	lbs

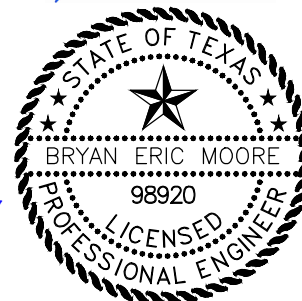
**16. Vegetated Filter Strips**

Designed as Required in RG-348

Pages 3-55 to 3-57

There are no calculations required for determining the load or size of vegetative filter strips.  
 The 80% removal is provided when the contributing drainage area does not exceed 72 feet (direction of flow) and the sheet flow leaving the impervious cover is directed across 15 feet of engineered filter strips with maximum slope of 20% or across 50 feet of natural vegetation with a maximum slope of 10%. There can be a break in grade as long as no slope exceeds 20%.

If vegetative filter strips are proposed for an interim permanent BMP, they may be sized as described on Page 3-56 of RG-348.

### **Attachment D – BMPs for Surface Streams**

There are no additional BMPs for minimizing pollutants from entering surface streams. The site will use vegetative filter strips to regulate and treat storm water runoff which will help to minimize surface stream contamination.

**Attachment E – Request to Seal Features**

There are no sensitive features that require sealing.

**Attachment F – Construction Plans**

See Attached Airport Road Improvements Construction Plans

## **Attachment G – Inspection, Maintenance, Repair and Retrofit Plan**

The following can be found in the TCEQ's "Complying with the Edwards Rules: Technical Guidance Manual on Best Management Practices."

### **Maintenance Guidelines for Vegetative Filter Strips**

Once a vegetated area is well established, little additional maintenance is generally necessary. The key to establishing a viable vegetated feature is the care and maintenance it receives in the first few months after it is planted. Once established, all vegetated BMPs require some basic maintenance to insure the health of the plants including:

- *Pest Management.* An Integrated Pest Management (IPM) Plan should be developed for vegetated areas. This plan should specify how problem insects and weeds will be controlled with minimal or no use of insecticides and herbicides.
- *Seasonal Mowing and Lawn Care.* If the filter strip is made up of turf grass, it should be mowed as needed to limit vegetation height to 18 inches, using a mulching mower (or removal of clippings). If native grasses are used, the filter may require less frequent mowing, but a minimum of twice annually. Grass clippings and brush debris should not be deposited on vegetated filter strip areas. Regular mowing should also include weed control practices, however herbicide use should be kept to a minimum (Urbonas et al., 1992). Healthy grass can be maintained without using fertilizers because runoff usually contains sufficient nutrients. Irrigation of the site can help assure a dense and healthy vegetative cover.
- *Inspection.* Inspect filter strips at least twice annually for erosion or damage to vegetation; however, additional inspection after periods of heavy runoff is most desirable. The strip should be checked for uniformity of grass cover, debris and litter, and areas of sediment accumulation. More frequent inspections of the grass cover during the first few years after establishment will help to determine if any problems are developing, and to plan for long-term restorative maintenance needs. Bare spots and areas of erosion identified during semi-annual inspections must be replanted and 3-92 restored to meet specifications. Construction of a level spreader device may be necessary to reestablish shallow overland flow.
- *Debris and Litter Removal.* Trash tends to accumulate in vegetated areas, particularly along highways. Any filter strip structures (i.e. level spreaders) should be kept free of obstructions to reduce floatables being flushed downstream, and for aesthetic reasons. The need for this practice is determined through periodic inspection, but should be performed no less than 4 times per year.
- *Sediment Removal.* Sediment removal is not normally required in filter strips, since the vegetation normally grows through it and binds it to the soil. However, sediment may





accumulate along the upstream boundary of the strip preventing uniform overland flow. Excess sediment should be removed by hand or with flat-bottomed shovels.

- *Grass Reseeding and Mulching.* A healthy dense grass should be maintained on the filter strip. If areas are eroded, they should be filled, compacted, and reseeded so that the final grade is level. Grass damaged during the sediment removal process should be promptly replaced using the same seed mix used during filter strip establishment. If possible, flow should be diverted from the damaged areas until the grass is firmly established. Bare spots and areas of erosion identified during semi-annual inspections must be replanted and restored to meet specifications. Corrective maintenance, such as weeding or replanting should be done more frequently in the first two to three years after installation to ensure stabilization. Dense vegetation may require irrigation immediately after planting, and during particularly dry periods, particularly as the vegetation is initially established.
- Inspections of the permanent BMPs shall be documented in the inspection reports.

**NOTE:** This Inspection, Maintenance, Repair and Retrofit Plan for the **Airport Road Improvements Filter Strips** were created and designed by the engineer of this BMP. Maintenance is the responsibility of the Owner and should be followed in accordance with this plan in order to keep the BMPs operating correctly.

DocuSigned by:  
Jimmy C Jones 8/9/2023  
97E2421E70C54DC...  
Jimmy Jones Date  
Georgetown Independent School District

  07/28/2023  
Bryan Moore, P.E. Date  
Steger Bizzell  
F-181

INSPECTOR: \_\_\_\_\_ DATE: \_\_\_\_\_

Inspectors Company: \_\_\_\_\_

Company Address: \_\_\_\_\_

\_\_\_\_\_  
\_\_\_\_\_

Company Phone: \_\_\_\_\_ Fax: \_\_\_\_\_

Date of Last Inspection: \_\_\_\_\_ Recent Heavy Rainfall: YES NO  
(CIRCLE ONE)

Status of BMP(s): \_\_\_\_\_

\_\_\_\_\_  
\_\_\_\_\_  
\_\_\_\_\_  
\_\_\_\_\_

Corrective Action Required (if any): \_\_\_\_\_

\_\_\_\_\_  
\_\_\_\_\_  
\_\_\_\_\_  
\_\_\_\_\_

Date Corrected (if applicable): \_\_\_\_\_

\*If actions are required they must be completed within 7 working days of this INSPECTION.

\_\_\_\_\_  
Inspectors Signature

\_\_\_\_\_  
Date:

**Agent Authorization Form**  
For Required Signature  
Edwards Aquifer Protection Program  
Relating to 30 TAC Chapter 213  
Effective June 1, 1999

I Mr. Jimmy Jones,  
Print Name

Director of Construction and Development,  
Title

of Georgetown ISD,  
Corporation/Partnership/Entity Name

have authorized Mr. Bryan Moore, P.E.  
Print Name of Agent/Engineer

of Steger Bizzell  
Print Name of Firm

to represent and act on the behalf of the above named Corporation, Partnership, or Entity for the purpose of preparing and submitting this plan application to the Texas Commission on Environmental Quality (TCEQ) for the review and approval consideration of regulated activities.

I also understand that:

1. The applicant is responsible for compliance with 30 Texas Administrative Code Chapter 213 and any condition of the TCEQ's approval letter. The TCEQ is authorized to assess administrative penalties of up to \$10,000 per day per violation.
2. For those submitting an application who are not the property owner, but who have the right to control and possess the property, additional authorization is required from the owner.
3. Application fees are due and payable at the time the application is submitted. The application fee must be sent to the TCEQ cashier or to the appropriate regional office. The application will not be considered until the correct fee is received by the commission.
4. A notarized copy of the Agent Authorization Form must be provided for the person preparing the application, and this form must accompany the completed application.
5. No person shall commence any regulated activity on the Edwards Aquifer Recharge Zone, Contributing Zone or Transition Zone until the appropriate application for the activity has been filed with and approved by the Executive Director.

SIGNATURE PAGE:

DocuSigned by:  
Jimmy C Jones  
97E3424E70C540C  
Applicant's Signature

8/8/2023  
Date

THE STATE OF TEXAS §

County of Travis §

BEFORE ME, the undersigned authority, on this day personally appeared Mr. Jimmy Jones known to me to be the person whose name is subscribed to the foregoing instrument, and acknowledged to me that (s)he executed same for the purpose and consideration therein expressed.

GIVEN under my hand and seal of office on this 8th day of August, 2023.

DocuSigned by:  
Jennifer Sparks  
NOTARY PUBLIC  
Jennifer Sparks  
Typed or Printed Name of Notary

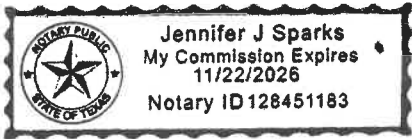

MY COMMISSION EXPIRES: 11/22/2026

# Application Fee Form

## Texas Commission on Environmental Quality

Name of Proposed Regulated Entity: Airport Road Improvements

Regulated Entity Location: Georgetown, TX

Name of Customer: Georgetown ISD / Steger Bizzell

Contact Person: Jimmy Jones Phone: 512-943-5129

Customer Reference Number (if issued): CN 600916712

Regulated Entity Reference Number (if issued): RN N/A

### Austin Regional Office (3373)

Hays

Travis

Williamson

### San Antonio Regional Office (3362)

Bexar

Medina

Uvalde

Comal

Kinney

Application fees must be paid by check, certified check, or money order, payable to the **Texas Commission on Environmental Quality**. Your canceled check will serve as your receipt. **This form must be submitted with your fee payment.** This payment is being submitted to:

Austin Regional Office

San Antonio Regional Office

Mailed to: TCEQ - Cashier

Overnight Delivery to: TCEQ - Cashier

Revenues Section

Mail Code 214

P.O. Box 13088

Austin, TX 78711-3088

12100 Park 35 Circle

Building A, 3rd Floor

Austin, TX 78753

(512)239-0357

### Site Location (Check All That Apply):

Recharge Zone

Contributing Zone

Transition Zone

<i>Type of Plan</i>	<i>Size</i>	<i>Fee Due</i>
Water Pollution Abatement Plan, Contributing Zone Plan: One Single Family Residential Dwelling	Acres	\$
Water Pollution Abatement Plan, Contributing Zone Plan: Multiple Single Family Residential and Parks	Acres	\$
Water Pollution Abatement Plan, Contributing Zone Plan: Non-residential	3.46 Acres	\$ 4,000
Sewage Collection System	0 L.F.	\$ 0.00
Lift Stations without sewer lines	Acres	\$
Underground or Aboveground Storage Tank Facility	Tanks	\$
Piping System(s)(only)	Each	\$
Exception	Each	\$
Extension of Time	Each	\$

Signature:  \_\_\_\_\_

Date: 7/28/2023

# Application Fee Schedule

Texas Commission on Environmental Quality

Edwards Aquifer Protection Program 30 TAC Chapter 213 (effective 05/01/2008)

## **Water Pollution Abatement Plans and Modifications**

### **Contributing Zone Plans and Modifications**

<b>Project</b>	<b>Project Area in Acres</b>	<b>Fee</b>
One Single Family Residential Dwelling	< 5	\$650
Multiple Single Family Residential and Parks	< 5	\$1,500
	5 < 10	\$3,000
	10 < 40	\$4,000
	40 < 100	\$6,500
	100 < 500	\$8,000
	≥ 500	\$10,000
Non-residential (Commercial, industrial, institutional, multi-family residential, schools, and other sites where regulated activities will occur)	< 1	\$3,000
	1 < 5	\$4,000
	5 < 10	\$5,000
	10 < 40	\$6,500
	40 < 100	\$8,000
	≥ 100	\$10,000

### **Organized Sewage Collection Systems and Modifications**

<b>Project</b>	<b>Cost per Linear Foot</b>	<b>Minimum Fee- Maximum Fee</b>
Sewage Collection Systems	\$0.50	\$650 - \$6,500

### **Underground and Aboveground Storage Tank System Facility Plans and Modifications**

<b>Project</b>	<b>Cost per Tank or Piping System</b>	<b>Minimum Fee- Maximum Fee</b>
Underground and Aboveground Storage Tank Facility	\$650	\$650 - \$6,500

### **Exception Requests**

<b>Project</b>	<b>Fee</b>
Exception Request	\$500

### **Extension of Time Requests**

<b>Project</b>	<b>Fee</b>
Extension of Time Request	\$150



# TCEQ Core Data Form

TCEQ Use Only

For detailed instructions regarding completion of this form, please read the Core Data Form Instructions or call 512-239-5175.

## SECTION I: General Information

<b>1. Reason for Submission</b> (If other is checked please describe in space provided)			
<input checked="" type="checkbox"/> New Permit, Registration or Authorization (Core Data Form should be submitted with the program application)			
<input type="checkbox"/> Renewal (Core Data Form should be submitted with the renewal form)		<input type="checkbox"/> Other	
<b>2. Attachments</b> Describe Any Attachments: (ex. Title V Application, Waste Transporter Application, etc.)			
<input type="checkbox"/> Yes <input checked="" type="checkbox"/> No			
<b>3. Customer Reference Number (if issued)</b>		<b>4. Regulated Entity Reference Number (if issued)</b>	
CN 600916712		RN	

## SECTION II: Customer Information

<b>5. Effective Date for Customer Information Updates (mm/dd/yyyy)</b>		7/28/2023	
<b>6. Customer Role</b> (Proposed or Actual) – as it relates to the <u>Regulated Entity</u> listed on this form. Please check only <u>one</u> of the following:			
<input checked="" type="checkbox"/> Owner		<input type="checkbox"/> Operator	
<input type="checkbox"/> Occupational Licensee		<input type="checkbox"/> Responsible Party	
<input type="checkbox"/> Owner & Operator		<input type="checkbox"/> Voluntary Cleanup Applicant	
		Other: _____	
<b>7. General Customer Information</b>			
<input type="checkbox"/> New Customer		<input type="checkbox"/> Update to Customer Information	
<input type="checkbox"/> Change in Legal Name (Verifiable with the Texas Secretary of State)		<input type="checkbox"/> Change in Regulated Entity Ownership	
		<input checked="" type="checkbox"/> No Change**	
<b>**If "No Change" and Section I is complete, skip to Section III – Regulated Entity Information.</b>			
<b>8. Type of Customer:</b>			
<input type="checkbox"/> Corporation		<input type="checkbox"/> Individual	
<input type="checkbox"/> City Government		<input type="checkbox"/> Sole Proprietorship- D.B.A	
<input type="checkbox"/> County Government		<input type="checkbox"/> Federal Government	
<input type="checkbox"/> Other		<input type="checkbox"/> State Government	
<input type="checkbox"/> General Partnership		<input checked="" type="checkbox"/> Limited Partnership	
		Other: _____	
<b>9. Customer Legal Name</b> (If an individual, print last name first: ex: Doe, John)			<i>If new Customer, enter previous Customer below</i>
Georgetown ISD			<i>End Date:</i>
<b>10. Mailing Address:</b>			
507 E University Ave			
City	Georgetown	State	TX
ZIP	78626	ZIP + 4	
<b>11. Country Mailing Information</b> (if outside USA)		<b>12. E-Mail Address</b> (if applicable)	
		jonesj10@georgetownisd.org	
<b>13. Telephone Number</b>		<b>14. Extension or Code</b>	
512-943-5129			
		<b>15. Fax Number</b> (if applicable)	
<b>16. Federal Tax ID</b> (9 digits)		<b>17. TX State Franchise Tax ID</b> (11 digits)	
		<b>18. DUNS Number</b> (if applicable)	
		<b>19. TX SOS Filing Number</b> (if applicable)	
<b>20. Number of Employees</b>		<b>21. Independently Owned and Operated?</b>	
<input type="checkbox"/> 0-20 <input type="checkbox"/> 21-100 <input type="checkbox"/> 101-250 <input checked="" type="checkbox"/> 251-500 <input type="checkbox"/> 501 and higher		<input type="checkbox"/> Yes <input checked="" type="checkbox"/> No	

## SECTION III: Regulated Entity Information

<b>22. General Regulated Entity Information</b> (If 'New Regulated Entity' is selected below this form should be accompanied by a permit application)			
<input checked="" type="checkbox"/> New Regulated Entity <input type="checkbox"/> Update to Regulated Entity Name <input type="checkbox"/> Update to Regulated Entity Information <input type="checkbox"/> No Change** (See below)			
**If "NO CHANGE" is checked and Section I is complete, skip to Section IV, Preparer Information.			
<b>23. Regulated Entity Name</b> (name of the site where the regulated action is taking place)			
Airport Road Improvements			

24. Street Address of the Regulated Entity: <i>(No P.O. Boxes)</i>	4090 Airport Rd						
	City	Georgetown	State	TX	ZIP	78628	ZIP + 4
25. Mailing Address:	507 E University Ave						
	City	Georgetown	State	TX	ZIP	78626	ZIP + 4
26. E-Mail Address:	jonesj10@georgetownisd.org						
27. Telephone Number	28. Extension or Code		29. Fax Number <i>(if applicable)</i>				
512-943-5129							
30. Primary SIC Code (4 digits)	31. Secondary SIC Code (4 digits)	32. Primary NAICS Code (5 or 6 digits)		33. Secondary NAICS Code (5 or 6 digits)			
8299		611110					
34. What is the Primary Business of this entity? <i>(Please do not repeat the SIC or NAICS description.)</i>							
Educational Facility							

Questions 34 – 37 address geographic location. Please refer to the instructions for applicability.

35. Description to Physical Location:	TRAVELING NORTH ON I-35, TAKE EXIT 264 TO N AUSTIN AVE. TURN LEFT ONTO N AUSTIN AVE AND CONTINUE FOR APPROXIMATELY 0.3 MILES. TURN LEFT ONTO LAKEWAY DR AND CONTINUE ONTO COUNTRY RD 190 A FOR APPROXIMATELY 0.1 MILES. TURN RIGHT ONTO AIRPORT ROAD AND CONTINUE FOR APPROXIMATELY 1.0 MILE AND THE SITE WILL BE ON THE LEFT						
36. Nearest City	County		State		Nearest ZIP Code		
Georgetown	Williamson		TX		78628		
37. Latitude (N) In Decimal:	30.72501		38. Longitude (W) In Decimal:	-97.771719			
Degrees	Minutes	Seconds	Degrees	Minutes	Seconds		
30	37	38.4636	-97	44	37.7118		

39. TCEQ Programs and ID Numbers Check all Programs and write in the permits/registration numbers that will be affected by the updates submitted on this form or the updates may not be made. If your Program is not listed, check other and write it in. See the Core Data Form instructions for additional guidance.

<input type="checkbox"/> Dam Safety	<input type="checkbox"/> Districts	<input checked="" type="checkbox"/> Edwards Aquifer	<input type="checkbox"/> Industrial Hazardous Waste	<input type="checkbox"/> Municipal Solid Waste
		WPAP 11002719		
<input type="checkbox"/> New Source Review – Air	<input type="checkbox"/> OSSF	<input type="checkbox"/> Petroleum Storage Tank	<input type="checkbox"/> PWS	<input type="checkbox"/> Sludge
<input type="checkbox"/> Stormwater	<input type="checkbox"/> Title V – Air	<input type="checkbox"/> Tires	<input type="checkbox"/> Used Oil	<input type="checkbox"/> Utilities
<input type="checkbox"/> Voluntary Cleanup	<input type="checkbox"/> Waste Water	<input type="checkbox"/> Wastewater Agriculture	<input type="checkbox"/> Water Rights	<input type="checkbox"/> Other:

#### SECTION IV: Preparer Information

40. Name:	Steger Bizzell – Bryan Moore, P.E.		41. Title:	Project Manager	
42. Telephone Number	43. Ext./Code	44. Fax Number	45. E-Mail Address		
( 512 ) 930-9412		( ) -	bmoore@stegerbizzell.com		

#### SECTION V: Authorized Signature

46. By my signature below, I certify, to the best of my knowledge, that the information provided in this form is true and complete, and that I have signature authority to submit this form on behalf of the entity specified in Section II, Field 9 and/or as required for the updates to the ID numbers identified in field 39.

*(See the Core Data Form instructions for more information on who should sign this form.)*

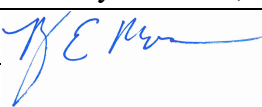
Company:	Steger Bizzell		Job Title:	Project Manager	
Name <i>(In Print)</i> :	Mr. Bryan Moore, P.E.			Phone:	( 512 ) 930-9412
Signature:				Date:	7/28/2023



# CONSTRUCTION PLANS FOR AIRPORT ROAD IMPROVEMENTS FOR FUTURE READY LEARNING COMPLEX GEORGETOWN I.S.D. PAVING & DRAINAGE IMPROVEMENTS CITY OF GEORGETOWN, WILLIAMSON COUNTY, TEXAS 2023-14-CON

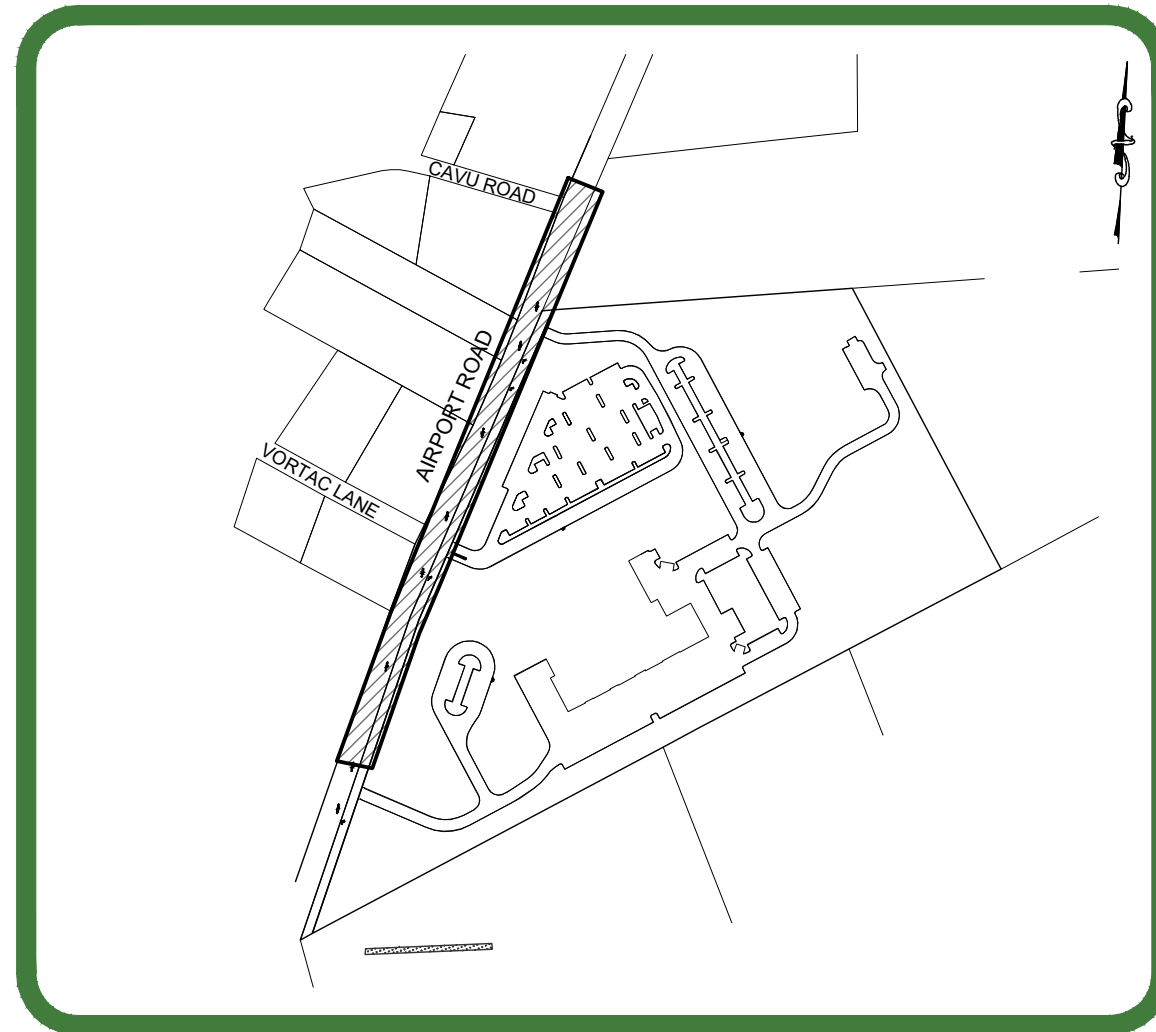

Location Map  
1" = 500'

### Sheet List Table

Sheet Number	Sheet Title
01	COVER SHEET
02	FINAL PLAT (1 OF 2)
03	FINAL PLAT (2 OF 2)
04	GENERAL NOTES (1 OF 2)
05	GENERAL NOTES (2 OF 2)
06	EXISTING DRAINAGE PLAN
07	DEVELOPED DRAINAGE PLAN
08	EROSION & SEDIMENTATION CONTROL PLAN
09	EROSION & SEDIMENTATION CONTROL DETAILS
10	WATER QUALITY PLAN
11	AIRPORT ROAD PLAN & PROFILE (1 OF 2)
12	AIRPORT ROAD PLAN & PROFILE (2 OF 2)
13	TRAFFIC CONTROL PLAN (1 OF 2)
14	TRAFFIC CONTROL PLAN (2 OF 2)
15	WORK ZONE (1 OF 2)
16	WORK ZONE (2 OF 2)
17	BARRICADES & CONSTRUCTION (1 OF 3)
18	BARRICADES & CONSTRUCTION (2 OF 3)
19	BARRICADES & CONSTRUCTION (3 OF 3)
20	DELINEATOR & OBJECT MARKERS
21	STRIPING AND SIGNAGE PLAN
22	PAVEMENT MARKINGS
23	SIGN MOUNTING DETAILS
24	OVERALL STORMWATER PLAN
25	CULVERT PLAN, PROFILE & CALCULATION
26	PAVING & DRAINAGE DETAILS
27	DITCH PROFILES
28	TREE PRESERVATION PLAN

**NOTE:**

- These construction plans were prepared, sealed, signed, and dated by a Texas Licensed Professional Engineer. Therefore based on the engineer's concurrence of compliance, the construction plans for construction of the proposed project are hereby approved subject to the Standard Construction Specifications and Details Manual and all other applicable City, State and Federal Requirements and Codes.
- This project is subject to all City Standard Specifications and Details in effect at the time of submittal of the project to the City.
- The limits of construction is 3.46 acres.
- Where no existing overhead infrastructures exists, underground electric utility lines shall be located along the street and within the site. Where existing overhead infrastructure is to be relocated, it shall be reinstalled underground and the existing facilities shall be removed at the discretion of the Development Engineer (only applicable for non-residential and multi-family development).
- All electric and communication infrastructure shall comply with UDC section 13.06
- All bearings and coordinates are referenced to the Texas Coordinate System, Central Zone. NAD 83 horizontal control datum and NAVD 88 vertical control datum. All coordinates are grid.
- The contractor shall obtain a "notice of proposed installation of utility line" permit from Williamson County for any work performed in the existing county right-of-way (driveway apron, water main tie-in, etc.) This permit application will require a liability agreement, a construction cost estimate for work within the right-of-way including pavement repair (if needed), a performance bond, construction plans and, if necessary, a traffic control plan. An inspection fee, and a pre-construction meeting may also be required, depending on the scope of work. The permit will be reviewed and approved by the County Engineer, and must also be approved by the Williamson County Commissioners Court if any road closure is involved.
- The property subject to this application is subject to the Water Quality regulations of the City of Georgetown.
- A Geological Assessment, in accordance with the City of Georgetown Water Quality Regulations, was completed on October 16, 2020. Any springs and streams as identified in the Geological Assessment are shown herein.

APPROVED for the City of Georgetown:

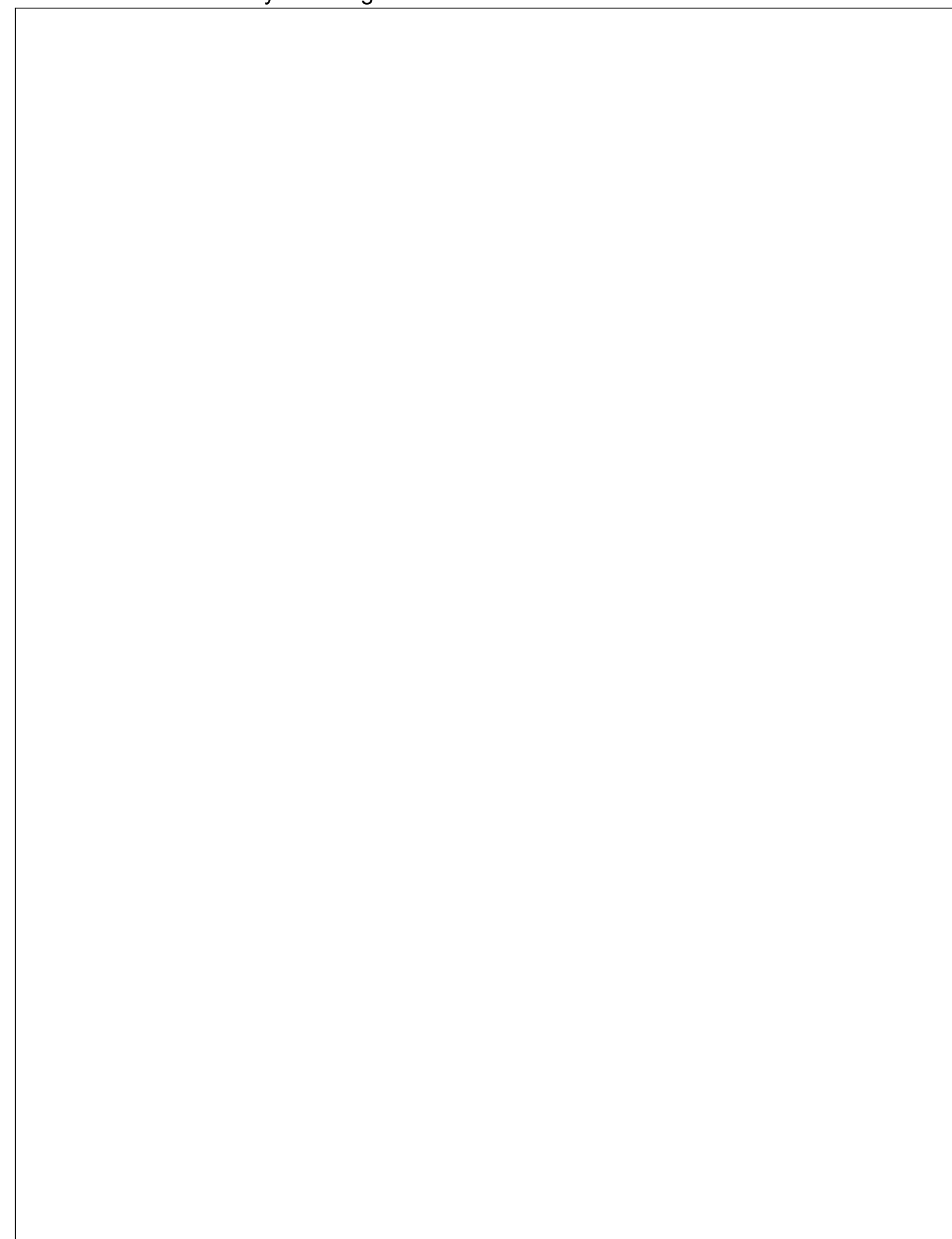

Submitted By:

Bryan E. Moore, P.E.

Date

REVIEWED FOR COMPLIANCE WITH COUNTY REQUIREMENTS

For Williamson County

Date

Date

BENCHMARKS:

OWNER / DEVELOPER

Georgetown Independent School District  
507 E. University Ave.  
Georgetown, TX 78626  
512-943-5000

SURVEYOR / ENGINEER / APPLICANT:



STEGER BIZZELL  
TBPLS FIRM NO. 10003700  
1978 S. AUSTIN AVE.  
GEORGETOWN, TEXAS 78626  
OFFICE: 512-930-9412  
CONTACT: BRYAN MOORE



TEXAS ONE-CALL 800-344-8377

**NOTE:**  
CONTRACTOR IS TO FURNISH A SET OF CONSTRUCTION PLANS BACK TO THE ENGINEER AT THE END OF THE PROJECT WITH ALL DEVIATIONS NOTED IN RED INK ON THE PLAN SHEETS. CONTRACTOR SHALL NOT RECEIVE FINAL PAYMENT UNTIL COMPLETE "AS-BUILT" SET IS RETURNED TO ENGINEER.



1978 S. AUSTIN AVENUE | GEORGETOWN, TX 78626  
512.930.9412 | TEXAS REGISTERED ENGINEERING FIRM F-181 | TBPLS FIRM NO. 10003700 | WEB: STEGERBIZZELL.COM  
>>>ENGINEERS >>>PLANNERS >>>SURVEYORS

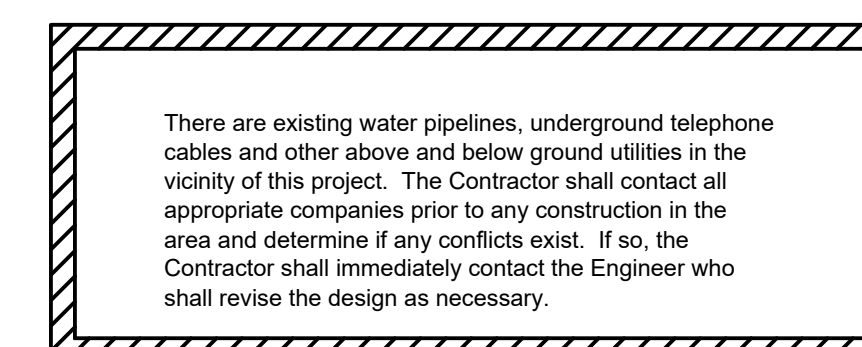

Project Number:  
22744-RDWY  
1 OF 28

2023-14-CON

These drawings are the sole property of STEGER & BIZZELL ENGINEERING, INC. The use of these drawings is hereby restricted to the original site for which they were prepared. Reproduction or reuse of these drawings in whole or in part without written permission of STEGER & BIZZELL ENGINEERING, INC. is strictly prohibited.

SEQUENCE OF CONSTRUCTION

- 1. Temporary erosion and sedimentation controls are to be installed as indicated on the approved construction plan and in accordance with the Stormwater Pollution Prevention Plan (SWPPP) that is required to be posted on the site. Install tree protection and initiate tree mitigation measures.
2. Prior to beginning construction, the Owner or his authorized representative, shall convene a Pre-Construction Conference between the City of Georgetown, Engineer, Contractor, County Engineer (if applicable), Texas Commission on Environmental Quality Field Office, and any other affected parties. Notify all such parties at least 48 hours prior to the time of the conference and 48 hours prior to beginning construction.
3. The Environmental Project Manager, and/or Site Supervisor, and/or Designated Responsible Party, and the General Contractor will follow the Storm Water Pollution Prevention Plan (SWPPP) posted on the site. Temporary erosion and sedimentation controls will be revised, if needed, to comply with City Inspectors' directives, and revised construction schedule relative to the water quality plan requirements and the erosion plan.
4. Rough grade the pond(s) at 100% proposed capacity. Either the permanent outlet structure or a temporary outlet must be constructed prior to development of embankment or excavation that leads to ponding conditions. The outlet system shall be protected from erosion and shall be maintained throughout the course of construction until installation of the permanent water quality pond(s).
5. Temporary erosion and sedimentation controls will be inspected and maintained in accordance with the Storm Water Pollution Prevention Plan (SWPPP) posted on the site.
6. Begin site clearing/construction activities.
7. Permanent water quality ponds or controls will be cleaned out and filter media will be installed prior to/concurrently with revegetation of the site.
8. Complete construction and start revegetation of the site and installation of landscaping.
9. Upon completion of the site construction and revegetation of a project site, a final inspection will be scheduled by the appropriate City Inspector.
10. After a final inspection has been conducted by the City Inspector and with approval from the City Inspector, remove the temporary erosion and sedimentation controls and complete any necessary final revegetation resulting from removal of the controls. Conduct any maintenance and rehabilitation of the water quality ponds or controls.

ACCESSIBILITY NOTES

- 1. Project shall be constructed in full compliance with the Texas Accessibility Standards (TAS) 2012.
2. Slopes in the direction of pedestrian travel shall not exceed 5% (1:20) or have a cross slope greater than 2% (1:48). This shall include routes that cross-vehicular ways including but not limited to pedestrian/vehicular ways such as street intersections.
A. Exception: Per TAS 405.8 and 68.102 (1) grades at the new sidewalks parallel to the streets shall be equal to, or less than, the street grade. Should the new sidewalks exceed the street grade, and the new sidewalk grades exceed 5% in the direction of travel, ramps complying with TAS 405 are required at these conditions.
3. Curb Ramps:
A. Curb ramps shall not exceed 8.3% (1:12) in the direction of pedestrian travel.
B. Curb ramps flares (wings) shall not exceed 1:10.
C. Minimum width of a curb ramp is 36".
D. Top of the curb ramp must be 2% in all directions for an area 36" wide and 48" deep.
E. When truncated domes are used, the truncated dome system shall extend the full width of the curb ramp and for a minimum depth of 24" at the bottom of the curb ramp.
F. Returned curb ramps shall only be used where the adjacent surface on one or both sides of the curb ramp do not allow pedestrian travel such as but not limited to stop lights, stop signs and permanently mounted waste receptacles.
4. There shall be no changes in level greater than 1/4" on any accessible route or 1/2" with a 1:2 bevel.
5. Decomposed granite surfaces, or similar Engineer-approved surfaces shall be compacted tight and maintained by the Owner at all times.
6. Provide directional signage using the international symbol of accessibility when not all routes are accessible. Signage shall be placed at the beginning of the route to avoid a patron from proceeding on a non-accessible route.
7. Verify that no plantings or other site elements on circulation paths would be protruding objects based on TAS 307 (protrudes more 4" and is higher than 27" from the surface and less than 80" from the surface).

Contractor shall notify the Engineer before proceeding with any Work, which is in conflict with the Texas Accessibility Standards. Contractor is financially responsible for proceeding with any Work without written direction on any clarification from the Engineer.

GENERAL CONSTRUCTION NOTES

- 1. Prior to beginning construction, the Owner or his authorized representative, shall convene a Pre-Construction Conference between the City of Georgetown, Engineer, Contractor, County Engineer (if applicable), Texas Commission on Environmental Quality Field Office, and any other affected parties. Notify all such parties at least 48 hours prior to the time of the conference and 48 hours prior to beginning construction.
2. Any existing utilities, pavement, curbs, and/or sidewalks damaged or removed shall be repaired by the Contractor at his expense before acceptance of the project.
3. The location of any existing water, wastewater lines or other utilities shall be verified by the City of Georgetown & other utility providers prior to construction.
4. Manhole frames, covers, water valve covers, etc., shall be raised to finished pavement grade at the Contractor's expense by a qualified contractor with City inspection. All utility adjustments shall be completed prior to final paving construction.
5. Steger Bizzell has endeavored to design these plans compliant with ADA/TDLR and other accessibility requirements. However, the contractor shall not be relieved of any responsibility for constructing these improvements compliant with all applicable accessibility standards. If the contractor notices any discrepancies between these plans and accessibility laws/rules, he is to stop work in the area of conflict and notify Steger Bizzell immediately for a resolution and/or revision to these plans. Steger Bizzell shall not be held responsible for constructing this site compliant with accessibility laws/rules regardless of what is shown in these plans.
6. Topography based upon mapping, dated August 8, 2016 by Texas Land Surveying. The contractor shall notify the design engineer in writing of any discrepancies discovered during construction prior to proceeding.
7. All work within the Ronald Reagan Boulevard right-of-way shall be governed by the TxDOT Standard Specifications for Construction of Highways, Streets and Bridges adopted on November 1, 2014 and all applicable special provisions and special specifications.

TCEQ WATER DISTRIBUTION SYSTEM GENERAL CONSTRUCTION NOTES

- 1. This water distribution system must be constructed in accordance with the current Texas Commission on Environmental Quality (TCEQ) Rules and Regulations for Public Water Systems 30 Texas Administrative Code (TAC) Chapter 290 Subchapter D. When conflicts are noted with local standards, the more stringent requirement shall be applied. Construction for public water systems must always, at a minimum, meet TCEQ's "Rules and Regulations for Public Water Systems.
2. An appointed engineer shall notify in writing the local TCEQ's Regional Office when construction will start. Please keep in mind that upon completion of the water works project, the engineer or owner shall notify the commission's Water Supply Division, in writing, as to its completion and attest to the fact that the work has been completed essentially according to the plans and change orders on file with the commission as required in 30 TAC §290.39(h)(3).
3. All newly installed pipes and related products must conform to American National Standards Institute (ANSI)/NSF International Standard 61 and must be certified by an organization accredited by ANSI, as required by 30 TAC §290.44(a)(1).
4. Plastic pipe for use in public water systems must bear the NSF International Seal of Approval (NSF-pw) and have an ASTM design pressure rating of at least 150 psi or a standard dimension ratio of 26 or less, as required by 30 TAC §290.44(a)(2).
5. No pipe which has been used for any purpose other than the conveyance of drinking water shall be accepted or relocated for use in any public drinking water supply, as required by 30 TAC §290.44(a)(3).
6. Water transmission and distribution lines shall be installed in accordance with the manufacturer's instructions. However, the top of the water line must be located below the frost line and in no case shall the top of the water line be less than 24 inches below ground surface, as required by 30 TAC §290.44(a)(4).
7. Pursuant to 30 TAC §290.44(a)(5), the hydrostatic leakage rate shall not exceed the amount allowed or recommended by the most current AWWA formulas for PVC pipe, cast iron and ductile iron pipe. Include the formulas in the notes on the plans.
• The hydrostatic leakage rate for polyvinyl chloride (PVC) pipe and appurtenances shall not exceed the amount allowed or recommended by formulas in America Water Works Association (AWWA) C-605 as required in 30 TAC §290.44(a)(5). Please ensure that the formula for this calculation is correct and most current formula is in use;
Q = L x D x P^1/2 / 148,000
Q = the quantity of makeup water in gallons per hour,
L = the length of the pipe section being tested, in feet,
D = the nominal diameter of the pipe in inches, and
P = the average test pressure during the hydrostatic test in pounds per square inch (psi).
• The hydrostatic leakage rate for ductile iron (DI) pipe and appurtenances shall not exceed the amount allowed or recommended by formulas in America Water Works Association (AWWA) C-600 as required in 30 TAC §290.44(a)(5). Please ensure that the formula for this calculation is correct and most current formula is in use;
L = S x D x P^1/2 / 148,000
L = the quantity of makeup water in gallons per hour,
S = the length of the pipe section being tested, in feet,
D = the nominal diameter of the pipe in inches, and
P = the average test pressure during the hydrostatic test in pounds per square inch (psi).

- 8. The maximum allowable lead content of pipes, pipe fittings, plumbing fittings, and fixtures is 0.25 percent.
9. The system must be designed to maintain a minimum pressure of 35 psi at all points within the distribution network at flow rates of at least 1.5 gallons per minute per connection. When the system is intended to provide firefighting capability, it must also be designed to maintain a minimum pressure of 20 psi under combined fire and drinking water flow conditions as required by 30 TAC §290.44(d).
10. The contractor shall install appropriate air release devices in the distribution system at all points where topography or other factors may create air locks in the lines. All vent openings to the atmosphere shall be covered with 16-mesh or finer, corrosion resistant screening material or an acceptable equivalent as required by 30 TAC §290.44(d)(1).
11. Pursuant to 30 TAC §290.44(d)(4), accurate water meters shall be provided. Service connections and meter locations should be shown on the plans.
12. Pursuant to 30 TAC §290.44(d)(5), sufficient valves and blowoffs to make repairs. The engineering report shall establish criteria for this design.
13. Pursuant to 30 TAC §290.44(d)(6), the system shall be designed to afford effective circulation of water with a minimum of dead ends. All dead-end mains shall be provided with acceptable flush valves and discharge piping. All dead-end lines less than two inches in diameter will not require flush valves if they end at a customer service. Where dead ends are necessary as a stage in the growth of the system, they shall be located and arranged to ultimately connect the ends to provide circulation.
14. The contractor shall maintain a minimum separation distance in all directions of nine feet between the proposed waterline and wastewater collection facilities including manholes and septic tank drainfields. If this distance cannot be maintained, the contractor must immediately notify the project engineer for further direction. Separation distances, installation methods, and materials utilized must meet 30 TAC §290.44(e)(1-4) of the current rules.
15. Pursuant to 30 TAC §290.44(e)(5), the separation distance from a potable waterline to a wastewater main or lateral manhole or cleanout shall be a minimum of nine feet. Where the nine-foot separation distance cannot be achieved, the potable waterline shall be encased in a joint of at least 150 psi pressure class pipe at least 18 feet long and two nominal sizes larger than the new conveyance. The space around the carrier pipe shall be supported at

- five-foot intervals with spacers or be filled to the springline with washed sand. The encasement pipe shall be centered on the crossing and both ends sealed with cement grout or manufactured sealant.
16. Pursuant to 30 TAC §290.44(e)(6), fire hydrants shall not be installed within nine feet vertically or horizontally of any wastewater line, wastewater lateral, or wastewater service line regardless of construction.
17. Pursuant to 30 TAC §290.44(e)(7), suction mains to pumping equipment shall not cross wastewater mains, wastewater laterals, or wastewater service lines. Raw water supply lines shall not be installed within five feet of any tile or concrete wastewater main, wastewater lateral, or wastewater service line.
18. Pursuant to 30 TAC §290.44(e)(8), waterlines shall not be installed closer than ten feet to septic tank drainfields.
19. Pursuant to 30 TAC §290.44(f)(1), the contractor shall not place the pipe in water or where it can be flooded with water or sewage during its storage or installation.
20. Pursuant to 30 TAC §290.44(f)(2), when waterlines are laid under any flowing or intermittent stream or semi-permanent body of water the water main shall be installed in a separate watertight pipe encasement. Valves must be provided on each side of the crossing with facilities to allow the underwater portion of the system to be isolated and tested.
21. The contractor shall disinfect the new water mains in accordance with AWWA Standard C-651 and then flush and sample the lines before being placed into service. Samples shall be collected for microbiological analysis to check the effectiveness of the disinfection procedure which shall be repeated if contamination persists. A minimum of one sample for each 1,000 feet of completed water line will be required or at the next available sampling point beyond 1,000 feet as designated by the design engineer, in accordance with 30 TAC §290.44(f)(3).

CITY OF GEORGETOWN GENERAL NOTES

- 1. These construction plans were prepared, sealed, signed and dated by a Texas Licensed Professional Engineer. Therefore based on the engineer's concurrence of compliance, the construction plans for construction of the proposed project are hereby approved subject to the standard Construction Specifications and Details Manual and all other applicable City, State and Federal Requirements and Codes.
2. This project is subject to all City Standard Specifications and Details in effect at the time of submittal of the project to the City.
3. The site construction plans shall meet all requirements of the approved site plan.
4. Wastewater mains and service lines shall be SDR 26 PVC.
5. Wastewater mains shall be installed without horizontal or vertical bends.
6. Maximum distance between wastewater manholes is 500 feet.
7. Wastewater mains shall be low pressure air tested and mandrel tested by the contractor according to the City of Georgetown and TCEQ requirements.
8. Wastewater manholes shall be vacuum tested and coated by the contractor according to City of Georgetown and TCEQ requirements.
9. Wastewater mains shall be camera tested by the contractor and submitted to the City on DVD format prior to paving the streets.
10. Private water system fire lines shall be tested by the contractor to 200 psi for 2 hours.
11. Private water system fire lines shall be ductile iron piping from the water main to the building sprinkler system, and 200 psi C900 PVC for all others.
12. Public water system mains shall be 150 psi C900 PVC and tested by the contractor at 150 psi for 4 hours.
13. All bends and changes in direction on water mains shall be restrained and thrust blocked.
14. Long fire hydrant leads shall be restrained.
15. All water lines are to be bacteria tested by the contractor according to the City standards and specifications.
16. Water and Sewer main crossings shall meet all requirements of the TCEQ and the City.
17. Flexible base material for public streets shall be TxDOT Type A Grade 1.
18. Hot mix asphaltic concrete pavement shall be Type D unless otherwise specified and shall be a minimum of 2 inches thick on public streets and roadways.
19. All sidewalk ramps and sidewalks not intended to be constructed with the individual houses shall be installed with the public infrastructure.
20. A maintenance bond is required to be submitted to the City prior to acceptance of the public improvements. This bond shall be established for 2 years in the amount of 10% of the cost of the public improvements and shall follow the City format.
21. Record drawings of the public improvements shall be submitted to the City by the design engineer prior to acceptance of the project. These drawings shall be TIFF or PDF disk (300 dpi).
22. All electrical distribution lines and individual services shall be installed underground. If overhead lines existed prior to underground installation, such poles, guy wires and related structures shall be removed following construction of the underground infrastructure.
23. All electric and communication infrastructure shall comply with UDC section 13.06

PERMANENT EROSION CONTROL NOTES

- 1. All disturbed areas shall be restored as noted below:
a. A minimum of four inches of imported sandy loam topsoil or approved equal shall be placed in all drainage channels (except rock) and on all cleared areas.
b. Grass areas may be sodded, plugged, sprigged or seeded except that solid sod shall be used in swales or other areas subject to erosion.
The seeding for permanent erosion control shall be applied over areas disturbed by construction as follows, unless specified elsewhere:
i. From September 15 to March 1, seeding shall be with a combination of 1 pound per 1,000 square feet of unhulled Bermuda and 7 pounds per 1,000 square feet of Winter Rye with a purity of 95% with 90% germination.
ii. From March 2 to September 14, seeding shall be with hulled Bermuda at a rate of 3 pounds per 1,000 square feet with a purity of 95% with 85% germination.
c. Fertilizer shall be slow release granular or pelleted type and shall have an analysis of 15-15-15 and shall be applied at the rate of 23 pounds per acre once at the time of planting and again once during the time of establishment.
d. All planted areas shall be provided with a readily available water supply and watered as necessary to ensure continuous healthy growth and development. The planted area shall be irrigated or sprinkled in a manner that will not erode the top soil, but will sufficiently soak the soil to a depth of six inches. The irrigation shall occur at ten-day intervals during the first two months. Rainfall occurrences of 1/2 inch or more shall postpone the watering schedule for one week.
e. Mulch type used shall be Mulch, applied at a rate of 1,500 pounds per acre.
2. Disturbed areas within areas to become public shall be re-vegetated to the City of Georgetown requirements. See section G7 of the City of Georgetown Specifications.

WILLIAMSON COUNTY CONSTRUCTION NOTES

- B4 - Construction -- General
B4.1 A preconstruction meeting shall be scheduled prior to the start of construction. The Design Engineer, Owner, Contractor, Subcontractors, and County Engineer shall attend this meeting. All roads are to be constructed in accordance with the construction documents as approved by the County Engineer and in accordance with the specifications found in the current version of the "Texas Department of Transportation Manual Standard Specifications for Construction of Highways, Streets, and Bridges" unless otherwise stated on the construction documents approved by the County Engineer.
B4.2 All materials shall be sampled and tested by an Independent Testing Laboratory in accordance with the construction documents approved by the County Engineer. The Owner shall pay for all testing services and shall furnish the County Engineer with certified copies of these test results. The County Engineer must approve the test results prior to constructing the next course of the roadway structure. Any material which does not meet the minimum required test specifications shall be removed and recompacted or replaced unless alternative remedial action is approved in writing from the County Engineer.
B4.3 Except for electrical lines, all underground nonferrous utilities within a right-of-way or easement must be accompanied by ferrous metal lines to aid in tracing the location of said utilities through the use of a metal detector.
B4.4 All pavements are to be designed by a Registered Professional Engineer. The design shall be based on a 20-year design life and in conjunction with recommendations based upon a soils report of samples taken along the proposed roadways. Test borings shall be placed at a maximum spacing of 500 feet or other sampling frequency approved by the County Engineer based on recommendations provided by the geotechnical engineer. The soils report and pavement design shall be submitted to the County Engineer for review. The pavement design must be approved by the County Engineer prior to or concurrently with the review and approval of the construction plans. In addition to the basis of the pavement design, the soils report shall contain the results of sampled and tested subgrade for plasticity index, pH, sulfate content, and maximum density.
B5 - Subgrade
B5.1 The preparation of the subgrade shall follow good engineering practices as directed by the County Engineer in conjunction with recommendations outlined in the geotechnical report. When the Plasticity Index (PI) is greater than 20, a sufficient amount of lime shall be added as described in Item 260 of the current edition of the TxDOT Standard Specifications for Construction until the PI is less than 20. If the addition of lime as described in Item 260 is not feasible, an alternate stabilizing design shall be proposed and submitted to the County Engineer for approval. The subgrade shall be prepared and compacted to achieve a dry density per TxDOT Item 132. In addition, proof rolling may be required by the County Engineer.
B5.2 The subgrade shall be inspected and approved by an Independent Testing Laboratory and a certified copy of all inspection reports furnished to the County Engineer, who must approve the report prior to application of the base material. All density test reports shall include a copy of the work sheet showing the percentage of the maximum dry (Proctor) density. The number and location of all subgrade tests shall be determined by the County Engineer.

- B6 - Base Material
B6.1 Base material shall conform to Item 247 of the current edition of the TxDOT Standard Specifications for Construction, "Flexible Base". The base material shall be Type A Grade 1, Type A Grade 2, or as approved by the County Engineer.
B6.2 Each layer of base course shall be tested for in-place dry density and measured for compacted thickness. The number and location of all base test samples shall be determined by the County Engineer.
B6.3 The base shall be prepared and compacted to achieve a minimum of 100% of the maximum (Proctor) dry density or as approved by the County Engineer upon recommendation by the testing laboratory. The maximum lift shall not exceed six inches. The base must be inspected and approved by an Independent Testing Laboratory and a certified copy of the test results furnished to the County Engineer for approval. Prior to the placement of the first lift of base, the stockpile shall be tested for the specifications found in Item 247 Table 1 and the result furnished to the County Engineer for approval

- B7 - Bituminous Pavement
B7.1 Urban roads require a minimum 2 inch wearing surface of HMAC Type D. The mix shall be from a TxDOT certified plant. The mix design shall be submitted to the County Engineer for approval prior to placement of the material. Contractor's Quality Control (CQC) test reports shall be submitted to the County Engineer on a daily basis. As a minimum, daily CQC testing on the produced mix shall include: Sieve Analysis TEX-200-F, Asphalt Content TEX-210-F, Hveem Stability TEX-208-F, Laboratory Compacted Density TEX-207-F, and Maximum Specific Gravity TEX-227-F. The number and location of all HMAC tests shall be determined by the County Engineer with a minimum of three, 6-inch diameter field cores secured and tested by the contractor from each day's paving. Each HMAC course shall be tested for in-place density, bituminous content and aggregate gradation, and shall be measured for compacted thickness. The number and location of all HMAC test samples shall be determined by the County Engineer.
B7.2 Rural roads may use either the specifications found in Section B7.1 or a two-course surface in accordance with Item 316, treatment wearing surface, of the current edition of the TxDOT Standard Specifications for Construction. The type and rate of asphalt and aggregate shall be indicated on the plans as a basis of estimate and shall be determined at the preconstruction conference. Aggregate used in the mix shall be on the TxDOT Quality Monitoring Schedule. Aggregate shall be Type B Grade 4. Gradation tests shall be required for each 300 cubic yards of material placed with a minimum of two tests per each grade per each project. Test results shall be reviewed by the County Engineer prior to application of the material.

- B9 - Concrete - General
B9.1 Unless otherwise specified, concrete shall be in accordance with Item 421 of the current edition of the TxDOT Standard Specifications for Construction and be placed in accordance with the applicable item.
B9.2 All concrete shall be tested for compressive strength. One set of three concrete test cylinders shall be molded for every 50 cubic yards of concrete placed for each class of concrete per day, or at any other interval as determined by the County Engineer. A slump test shall be required with each set of test cylinders. One cylinder shall be tested for compressive strength at an age of seven days and the remaining two cylinders shall be tested at 28 days of age.

TEXAS COMMISSION ON ENVIRONMENTAL QUALITY CONTRIBUTING ZONE PLAN GENERAL CONSTRUCTION NOTES

Edwards Aquifer Protection Program Construction Notes - Legal Disclaimer
The following/listed "construction notes" are intended to be advisory in nature only and do not constitute an approval or conditional approval by the Executive Director (ED), nor do they constitute a comprehensive listing of rules or conditions to be followed during construction. Further actions may be required to achieve compliance with TCEQ regulations found in Title 30, Texas Administrative Code (TAC), Chapters 213 and 217, as well as local ordinances and regulations providing for the protection of water quality. Additionally, nothing contained in the following/listed "construction notes" restricts the powers of the ED, the commission or any other governmental entity to prevent, correct, or curtail activities that result or may result in pollution of the Edwards Aquifer or hydrologically connected surface waters. The holder of any Edwards Aquifer Protection Plan containing "construction notes" is still responsible for compliance with Title 30, TAC, Chapters 213 or any other applicable TCEQ regulation, as well as all conditions of an Edwards Aquifer Protection Plan through all phases of plan implementation. Failure to comply with any condition of the ED's approval, whether or not in contradiction of any "construction notes," is a violation of TCEQ regulations and any violation is subject to administrative rules, orders, and penalties as provided under Title 30, TAC § 213.10 (relating to Enforcement). Such violations may also be subject to civil penalties and injunction. The following/listed "construction notes" in no way represent an approved exception by the ED to any part of Title 30 TAC, Chapters 213 and 217, or any other TCEQ applicable regulation

- 1. A written notice of construction must be submitted to the TCEQ regional office at least 48 hours prior to the start of any ground disturbance or construction activities. This notice must include:
- the name of the approved project;
- the activity start date; and
- the contact information of the prime contractor.
2. All contractors conducting regulated activities associated with this project should be provided with complete copies of the approved Contributing Zone Plan (CZP) and the TCEQ letter indicating the specific conditions of its approval. During the course of these regulated activities, the contractor(s) should keep copies of the approved plan and approval letter on-site.
3. No hazardous substance storage tank shall be installed within 150 feet of a water supply source, distribution system, well, or sensitive feature.
4. Prior to beginning any construction activity, all temporary erosion and sedimentation (E&S) control measures must be properly installed and maintained in accordance with the manufacturers specifications. If inspections indicate a control has been used inappropriately, or incorrectly, the applicant must replace or modify the control for site situations. These controls must remain in place until the disturbed areas have been permanently stabilized.
5. Any sediment that escapes the construction site must be collected and properly disposed of before the next rain event to ensure it is not washed into surface streams, sensitive features, etc.
6. Sediment must be removed from the sediment traps or sedimentation basins when it occupies 50% of the basin's design capacity.
7. Litter, construction debris, and construction chemicals exposed to stormwater shall be prevented from being discharged offsite.
8. All excavated material that will be stored on-site must have proper E&S controls.
9. If portions of the site will have a cease in construction activity lasting longer than 14 days, soil stabilization in those areas shall be initiated as soon as possible prior to the 14th day of inactivity. If activity will resume prior to the 21st day, stabilization measures are not required. If drought conditions or inclement weather prevent action by the 14th day, stabilization measures shall be initiated as soon as possible.
10. The following records should be maintained and made available to the TCEQ upon request:
- the dates when major grading activities occur;
- the dates when construction activities temporarily or permanently cease on a portion of the site; and
- the dates when stabilization measures are initiated.
11. The holder of any approved CZP must notify the appropriate regional office in writing and obtain approval from the executive director prior to initiating any of the following:
A. any physical or operational modification of any best management practices (BMPs) or structure(s), including but not limited to temporary or permanent ponds, dams, berms, silt fences, and diversionary structures;
B. any change in the nature or character of the regulated activity from that which was originally approved;
C. any change that would significantly impact the ability to prevent pollution of the Edwards Aquifer; or
D. any development of land previously identified as undeveloped in the approved contributing zone plan.

Austin Regional Office
12100 Park 35 Circle, Building A
Austin, Texas 78753-1808
Phone(512) 339-2929
Fax (512) 339-3795

TEMPORARY EROSION CONTROL NOTES

- 1. The Contractor shall install erosion/sedimentation controls and tree protective fencing prior to any site preparation work (clearing grubbing or excavation).
2. The placement of erosion/sedimentation controls shall be in accordance with the EROSION & SEDIMENTATION CONTROL PLAN.
3. Any significant variation in materials or locations of controls or fences from those shown on the approved plans must be approved by the City Engineer.
4. The Contractor is required to inspect all controls and fences at weekly intervals and after significant rainfall events to insure that they are functioning properly. The person(s) responsible for maintenance of controls and fences shall immediately make any necessary repairs to damaged areas. Silt accumulation at controls must be removed when the depth reaches six (6) inches.
5. Prior to final acceptance, haul roads and waterway crossings constructed for temporary Contractor access must be removed, accumulated sediment removed from the waterway and the area restored to the original grade and revegetated. All land clearing debris shall be disposed of in approved spoil disposal sites.
6. Field revisions to the EROSION & SEDIMENTATION CONTROL PLAN required by the Engineer or field inspector with the Texas Commission may be on Environmental Quality (TCEQ) during the course of construction to correct control inadequacies. Major revisions must be approved by the (TCEQ).
7. Add feature information upon receipt of Geologic Assessment.

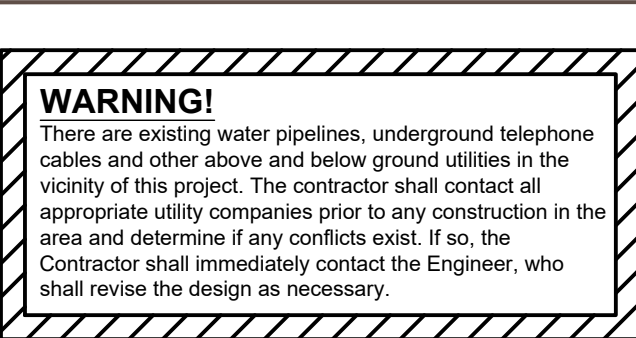

Table with 5 columns: NO., REVISION, BY, DATE. Includes fields for DESIGNED BY, DRAWN BY, CHECKED BY, APPROVED BY with corresponding DATE fields.

Professional Engineer seal for Bryan Eric Moore, State of Texas, License No. 98920, dated 07/27/2023.

STEGER BIZZELL logo and contact information: 1978 S. AUSTIN AVENUE, GEORGETOWN, TX 78626. METRO: 512.930.9412. SERVICES: >>ENGINEERS >>PLANNERS >>SURVEYORS.

GENERAL NOTES (1 OF 2) AIRPORT ROAD IMPROVEMENTS City of Georgetown Williamson County, Texas

Project Information Table: Project Number: 22744, SCALE: AS NOTED, Project Path: P:\22000-22999\22744, Project Name: AIRPORT RD. IMPROVEMENTS, Drawing Path: CAD\Plans, Sheet DWG FILE: , Xref Number: 04 of 28 sheets.

These drawings are the sole property of STEGER & BIZZELL ENGINEERING, INC. The use of these drawings is hereby restricted to the original site for which they were prepared. Reproduction or reuse of these drawings in whole or in part without written permission of STEGER & BIZZELL ENGINEERING, INC. is strictly prohibited.

**TEXAS COMMISSION ON ENVIRONMENTAL QUALITY ORGANIZED SEWAGE COLLECTION SYSTEM GENERAL CONSTRUCTION NOTES**

1. This Organized Sewage Collection System must be designed and constructed in accordance with the Texas Commission on Environmental Quality's (TCEQ) Edwards Aquifer Rules 30 Texas Administrative Code (TAC) §§213.5(c) and 217.51 - 217.70 and 30 TAC Chapter 217, Subchapter D, and the City of Georgetown Standard Specifications.

2. All contractors conducting regulated activities associated with this proposed regulated project must be provided with copies of the Sewage Collection System plan and the TCEQ letter indicating the specific conditions of its approval. During the course of these regulated activities, the contractors must be required to keep on-site copies of the plan and the approval letter.

3. No later than 48 hours prior to commencing any regulated activity, the applicant or its agent must notify the Austin Regional Office, in writing, of the date on which the regulated activity will begin.

4. Any modification to the activities described in the referenced SCS application following the date of approval may require the submission of an SCS application to modify this approval, including the payment of appropriate fees and all information necessary for its review and approval.

5. All temporary erosion and sedimentation controls must be installed prior to construction, must be maintained during construction, and must be removed when sufficient vegetation is established to control the erosion and sedimentation and the construction area is stabilized.

6. The sewer line trench details showing the cross section with the dimensions, pipe placement, and backfill instructions are included on Plan Sheet NA of these plans. All sewer pipes joints must meet the requirements in 30 TAC §217.53(c) at 217.65.

7. Gravity lines must have a SDR-26 or less. Pressurized sewer systems must have pipe with a minimum working pressure rating of 150 psi.

The ASTM, ANSI, or AWWA specification numbers for the pipe(s) and joints are: ASTM D 3034, F679, AWWAC900, CL150.

The pipe material, the pressure classes, and the SDR and/or DR designations are: PVC SDR-26, PS-115, DR-18.

8. If any sensitive features are discovered during the wastewater line trenching activities, all regulated activities near the sensitive feature must be suspended immediately. The applicant must immediately notify the appropriate regional office of the Texas Commission on Environmental Quality of the feature discovered. A geologist's assessment of the location and extent of the feature discovered must be reported to that regional office in writing within two working days. The applicant must submit a plan for ensuring the structural integrity of the sewer line or for modifying the proposed collection system alignment around the feature. The regulated activities near the sensitive feature may not proceed until the executive director has reviewed and approved the methods proposed to protect the sensitive feature and the Edwards Aquifer from any potentially adverse impacts to water quality while maintaining the structural integrity of the line.

9. Sewer lines located within or crossing the 5-year floodplain of a drainage way will be protected from inundation and stream velocities which could cause erosion and scouring of backfill. The trench must be capped with concrete to prevent scouring of backfill, or the sewer lines must be encased in concrete. All concrete shall have a minimum thickness of six (6) inches.

10. Blasting procedures for protection of existing sewer lines and other utilities will be in accordance with the National Fire Protection Association criteria. Sand is not allowed as bedding or backfill in trenches that have been blasted. If any existing sewer lines are damaged, the lines must be repaired and retested.

11. All manholes constructed or rehabilitated on this project must have watertight size on size resilient connectors allowing for differential settlement. If manholes are constructed within the 100-year floodplain, the cover must have a gasket and be bolted to the ring. Where gasketed manhole covers are required for more than three manholes in sequence or for more than 1500 feet, alternate means of venting will be provided. Bricks are not an acceptable construction material for any portion of the manhole.

The diameter of the manholes must be a minimum of four feet and the manhole for entry must have a minimum clear opening diameter of 30 inches. These dimensions and other details showing compliance with the commission's rules concerning manholes and sewer line/manhole inverts described in 30 TAC §217.55 are included on Plan Sheet NA.

It is suggested that entrance into manholes in excess of four feet deep be accomplished by means of a portable ladder. The inclusion of steps in a manhole is prohibited.

12. Where water lines and new sewer line are installed with a separation distance closer than nine feet (i.e., water lines crossing wastewater lines, water lines paralleling wastewater lines, or water lines next to manholes) the installation must meet the requirements of 30 TAC §217.53(d) (Pipe Design) and 30 TAC §290.44(e) (Water Distribution).

13. Where sewers lines deviate from straight alignment and uniform grade all curvature of sewer pipe must be achieved by the following procedure which is recommended by the pipe

manufacturer:  
NOT APPLICABLE.

If pipe flexure is proposed, the following method of preventing deflection of the joint must be used: NOT APPLICABLE.

Specific care must be taken to ensure that the joint is placed in the center of the trench and properly bedded in accordance with 30 TAC §217.54.

14. New sewage collection system lines must be constructed with stub outs for the connection of anticipated extensions. The location of such stub outs must be marked on the ground such that their location can be easily determined at the time of connection of the extensions. Such stub outs must be manufactured wyes or tees that are compatible in size and material with both the sewer line and the extension. At the time of original construction, new stub-outs must be constructed sufficiently to extend beyond the end of the street pavement. All stub-outs must be sealed with a manufactured cap to prevent leakage. Extensions that were not anticipated at the time of original construction or that are to be connected to an existing sewer line not furnished with stub outs must be connected using a manufactured saddle and in accordance with accepted plumbing techniques.

If no stub-out is present an alternate method of joining laterals is shown in the detail on Plan Sheet NA. (For potential future laterals).

The private service lateral stub-outs must be installed as shown on the plan and profile sheets on Plan Sheet NA and marked after backfilling as shown in the detail on Plan Sheet NA.

15. Trenching, bedding and backfill must conform with 30 TAC §217.54. The bedding and backfill for flexible pipe must comply with the standards of ASTM D-2321, Classes IA, IB, II or III. Rigid pipe bedding must comply with the requirements of ASTM C 12 (ANSI A 106.2) classes A, B or C.

16. Sewer lines must be tested from manhole to manhole. When a new sewer line is connected to an existing stub or clean-out, it must be tested from existing manhole to new manhole. If a stub or clean-out is used at the end of the proposed sewer line, no private service attachments may be connected between the last manhole and the cleanout unless it can be certified as conforming with the provisions of 30 TAC §213.5(c)(3)(E).

17. All sewer lines must be tested in accordance with 30 TAC §217.57. The engineer must retain copies of all test results which must be made available to the executive director upon request. The engineer must certify in writing that all wastewater lines

have passed all required testing to the appropriate regional office within 30 days of test completion and prior to use of the new collection system. Testing method will be:

17.a. For a collection system pipe that will transport wastewater by gravity flow, the design must specify an infiltration and exfiltration test or a low-pressure air test. A test must conform to the following requirements:

17.a.1. Low Pressure Air Test  
17.a.1.A. A low pressure air test must follow the procedures described in American Society For Testing And Materials (ASTM) C-828, ASTM C-924, or ASTM F-1417 or other procedure approved by the executive director, except as to testing times as required in Table C.3 in subparagraph (C) of this paragraph or Equation C.3 in subparagraph (B)(ii) of this paragraph.

17.a.1.B. For sections of collection system pipe less than 36 inch average inside diameter, the following procedure must apply, unless a pipe is to be tested as required by paragraph (2) of this subsection.

17.a.1.B.a. A pipe must be pressurized to 3.5 pounds per square inch (psi) greater than the pressure exerted by groundwater above the pipe.  
17.a.1.B.b. Once the pressure is stabilized, the minimum time allowable for the pressure to drop from 3.5 psi gauge to 2.5 psi gauge is computed from the following equation:

Equation C.3  $T = \frac{0.085 \times D \times K}{Q}$

Where:  
T = time for pressure to drop 1.0 pound per square inch gauge in seconds  
K = 0.000419 X D X L, but not less than 1.0  
D = average inside pipe diameter in inches  
L = length of line of same size being tested, in feet  
Q = rate of loss, 0.0015 cubic feet per minute per square foot internal surface

Since a K value of less than 1.0 may not be used, the minimum testing time for each pipe diameter is shown in the following Table C.3:

PIPE DIAMETER (IN)	MINIMUM TIME (SEC)	MAXIMUM LENGTH FOR MINIMUM TIME (FT)	TIME FOR LONGER LENGTH (SEC/FT)
6	340	398	0.8550
8	454	298	1.5200
10	567	239	2.3740
12	680	199	3.4190
15	850	159	5.3420
18	1020	133	7.6930
21	1190	114	10.4710
24	1360	100	13.6760
27	1530	88	17.3090
30	1700	80	21.3690
33	1870	72	25.8560

17.a.1.C. An owner may stop a test if no pressure loss has occurred during the first 25% of the calculated testing time.

17.a.1.D. If any pressure loss or leakage has occurred during the first 25% of a testing period, then the test must continue for the entire test duration as outlined above or until failure.

17.a.1.E. Wastewater collection system pipes with a 27 inch or larger average inside diameter may be air tested at each joint instead of following the procedure outlined in this section.

17.a.1.F. A testing procedure for pipe with an inside diameter greater than 33 inches must be approved by the executive director.

17.a.2. Infiltration/Exfiltration Test.  
17.a.2.A. The total exfiltration, as determined by a hydrostatic head test, must not exceed 50 gallons per inch of diameter per mile of pipe per 24 hours at a minimum test head of 2.0 feet above the crown of a pipe at an upstream manhole.

17.a.2.B. An owner shall use an infiltration test in lieu of an exfiltration test when pipes are installed below the groundwater level.

17.a.2.C. The total exfiltration, as determined by a hydrostatic head test, must not exceed 50 gallons per inch diameter per mile of pipe per 24 hours at a minimum test head of two feet above the crown of a pipe at an upstream manhole, or at least two feet above existing groundwater level, whichever is greater.

17.a.2.D. For construction within a 25-year flood plain, the infiltration or exfiltration must not exceed 10 gallons per inch diameter per mile of pipe per 24 hours at the same minimum test head as in subparagraph (C) of this paragraph.

17.a.2.E. If the quantity of infiltration or exfiltration exceeds the maximum quantity specified, an owner shall undertake remedial action in order to reduce the infiltration or exfiltration to an amount within the limits specified. An owner shall retest a pipe following a remediation action.

17.b. If a gravity collection pipe is composed of flexible pipe, deflection testing is also required. The following procedures must be followed:

17.b.1. For a collection pipe with inside diameter less than 27 inches, deflection measurement requires a rigid mandrel.

17.b.1.A. Mandrel Sizing.  
17.b.1.A.a. A rigid mandrel must have an outside diameter (OD) not less than 95% of the base inside diameter (ID) or average ID of a pipe, as specified in the appropriate standard by the ASTMs, American Water Works Association, UNI-BELL, or American National Standards Institute, or any related appendix. If a mandrel sizing diameter is not specified in the appropriate standard, the mandrel must have an OD equal to 95% of the ID of a pipe. In this case, the ID of the pipe, for the purpose of determining the OD of the mandrel, must equal the average outside diameter minus two minimum wall thicknesses for OD controlled pipe and the average inside diameter for ID controlled pipe.

17.b.1.A.b. All dimensions must meet the appropriate standard.  
17.b.1.B. Mandrel Design.  
17.b.1.B.a. A rigid mandrel must be constructed of a metal or a rigid plastic material that can withstand 200 psi without being deformed.  
17.b.1.B.b. A mandrel must have nine or more odd number of runners or legs.  
17.b.1.B.c. A barrel section length must equal at least 75% of the inside diameter of a pipe.  
17.b.1.B.d. Each size mandrel must use a separate proving ring.

17.b.1.C. Method Options.  
17.b.1.C.a. An adjustable or flexible mandrel is prohibited.

17.b.1.C.b. A test may not use television inspection as a substitute for a deflection test.

17.b.1.C.c. If requested, the executive director may approve the use of a deflectometer or a mandrel with removable legs or runners on a case-by-case basis.

17.b.2. For a gravity collection system pipe with an inside diameter 27 inches and greater, other test methods may be used to determine vertical deflection.

17.b.3. A deflection test method must be accurate to within plus or minus 0.2% deflection.

17.b.4. An owner shall not conduct a deflection test until at least 30 days after the final backfill.

17.b.5. Gravity collection system pipe deflection must not exceed five percent (5%).

17.b.6. If a pipe section fails a deflection test, an owner shall correct the problem and conduct a second test after the final backfill has been in place at least 30 days.

18. All manholes must be tested to meet or exceed the requirements of 30 TAC §217.58.

19. All private service laterals must be inspected and certified in accordance with 30 TAC §213.5(c)(3)(I). After installation of and, prior to covering and connecting a private service lateral to an existing organized sewage collection system, a Texas Licensed Professional Engineer, Texas Registered Sanitarian, or appropriate city Inspector must visually inspect the private service lateral and the connection to the sewage collection system, and certify that it is constructed in conformity with the applicable provisions of this section. The owner of the collection system must maintain such certifications for five years and forward copies to the appropriate regional office upon request. Connections may only be made to an approved sewage collection system.

**THESE GENERAL CONSTRUCTION NOTES MUST BE INCLUDED ON THE CONSTRUCTION PLANS PROVIDED TO THE CONTRACTOR AND ALL SUBCONTRACTORS**

MANHOLE TESTING

All manholes must pass a leakage test. An owner shall test each manhole (after assembly and backfilling) for leakage, separate and independent of the collection system pipes, by hydrostatic exfiltration testing, vacuum testing, or other method approved by the executive director.

HYDROSTATIC TESTING

The maximum leakage for hydrostatic testing or any alternative test methods is 0.025 gallons per foot diameter per foot of manhole depth per hour. To perform a hydrostatic exfiltration test, an owner shall seal all wastewater pipes coming into a manhole with an internal pipe plug, fill the manhole with water and maintain the test for at least one hour. A test for concrete manholes may use a 24 hour wetting period before testing to allow saturation of the concrete.

VACUUM TESTING

To perform a vacuum test, an owner shall plug all lift holes and exterior joints with a non-shrink grout and plug all pipes entering a manhole. No grout must be placed in horizontal joints before testing. Stub outs, manhole boots and pipe plugs must be secured to prevent movement while a vacuum is drawn. An owner shall use a minimum 60 inch/lb torque wrench to tighten the external clamps that secure a test cover to the top of a manhole. A test head must be placed at the inside of the top of a cone section and the seal inflated in accordance with the manufacturer's recommendations. There must be a vacuum of 10 inches of mercury inside a manhole to perform a valid test. A test does not begin until after the vacuum pump is off. A manhole passes the test if after 2.0 minutes and with all valves closed, the vacuum is a least 9.0 inches of mercury.

**NORTHWEST WILLIAMSON COUNTY MUNICIPAL UTILITY DISTRICT NO. 2 NOTES:**

The District Engineer, Jones-Heroy & Associates, Inc. (Ken Heroy, Ph:512/989-2200) shall be contacted 48 hours prior to:

- i) Pre-construction meetings;
- ii) Beginning each phase of construction;
- iii) Testing; and,
- iv) Final walk-through of facilities.

**ADDITIONAL WASTEWATER NOTES**

- 1. If a conflict exists between the various documents, the documents will take precedence in the following order:
  - a. Municipal Utility Specifications
  - b. Change Orders
  - c. Addenda Issue During Bidding
  - d. Construction Plans
  - e. Project Specifications
- 2. The following pipe diameters, pipe material and national standard specifications are proposed for this project:

PIPE DIAMETER (IN)	LINEAR FEET (FT)	PIPE MATERIAL	NATIONAL STANDARD FOR PIPE MATERIAL	NATIONAL STANDARD FOR PIPE JOINTS
8	0	PVC SDR-26	ASTM D 3034	ASTM D 3212
8	0	PVC DR-18	ASTM D 3034	ASTM D 3212
12	0	PVC SDR-26	ASTM D 3034	ASTM D 3212

- 3. Watertight, size on size resilient connectors conforming to ASTM C 923 must be used for connecting pipe to manholes.
- 4. The bedding class for each diameter of flexible pipe and each flexible pipe material is as follows:

PIPE DIAMETER (IN)	PIPE MATERIAL	BEDDING CLASS
8	PVC SDR-26/DR-18	1B
12	PVC SDR-26/DR-18	1B
15	PVC SDR-26/DR-18	1B
18	PVC PS-115/DR-18	1B
21	PVC PS-115/DR-18	1B

- 5. Brick manhole construction is not allowed. Use of brick for adjusting manhole covers to grade is also prohibited.
- 6. All manholes shall be of precast concrete construction.

- 7. The structural integrity of the collection line due to high soil P.I.'s will require the bedding around the pipe to be 6" minimum below the pipe, 6" minimum on each side of the pipe, and 12" minimum above the pipe.

- 8. If faults, caverns, or subsidence are discovered during construction, construction shall be halted to allow the features to be inspected by the design engineer or a geological or geotechnical engineer. Based on this inspection, revisions approval to the design may be required.

- 9. The trench walls shall be vertical to at least one foot above the pipe.

- 10. The trench backfill shall be free of stones greater than 6 inches in diameter and free of organic or any other unstable material.

- 11. Manholes shown on the plans with sealed and gasketed covers are provided as protection against inflow for those manholes which lie 1) within a 100 year flood plain, 2) lie within a drainage way, 3) lie within a street subject to carrying drainage flows, and 4) additional locations as determined necessary by the Engineer.

- 12. No drop connections are proposed in these plans.

- 13. The minimum allowable tensile strength and cell class for each flexible pipe shall be as follows:

PIPE MATERIAL	TENSILE STRENGTH	CELL CLASS (PVC ONLY)
SDR-26	7,000	12454-B
PS-115	7,000	12454-B

- 14. All gravity lines utilizing flexible pipe must be tested for deflection by pulling a rigid mandrel through the installed pipe. The test must be conducted at least 30 days after placement and compaction of final backfill. No pipe shall exceed a deflection of 5 rigid mandrel shall be used to measure deflection. The test must be performed without mechanical pulling devices. The mandrel's minimum outside diameter is 95 inside diameter. The mandrel must have an odd number of runners, totaling nine or more. The barrel section of the mandrel must have a length at least 75 inside diameter. A TV test cannot substitute for the deflection test.

- 15. A leakage test is required for all gravity lines. For line that is not horizontally curved, a hydrostatic test and/or a low pressure air test must be performed on all proposed gravity sanitary sewer collection piping. These tests must comply with Section 217.57(a) of the TCEQ's rules. The contractor shall have the option of utilizing either a hydrostatic test or a low pressure air test.

- 16. Manholes must be tested for leakage. Manholes will be tested with a hydrostatic test, or with a vacuum test, Contractor's Option.

- 17. The hydrostatic manhole test shall comply with the test requirements detailed in Section 217.58(b)(1) of the TCEQ's rules.

- 18. Each manhole shall be tested immediately after assembly and prior to backfilling. Manholes which have been backfilled shall either be excavated to expose the entire exterior prior to vacuum testing or the manhole shall be tested for leakage by means of a hydrostatic test.

- 19. All lift holes and exterior joints shall be plugged with an approved non-shrink grout.

- 20. No grout shall be placed in horizontal joints before testing.

- 21. All pipes entering the manhole shall be plugged, taking care to securely brace the plugs from being drawn into the manhole.

- 22. Stubouts, manhole boots and pipe plugs shall be secured to prevent movement while the vacuum is drawn.

- 23. A minimum 60-inch/lb torque wrench shall be used to tighten the external clamps that secure the test cover to the top of the manhole.

- 24. The test head shall be placed at the inside of the top of the cone section and the seal inflated in accordance with the manufacturer's recommendation.

- 25. A vacuum of 10 inches of mercury shall be drawn and the vacuum pump shut off. With the valves closed, the time shall be measured for the vacuum to drop to 9 inches of mercury. The manhole shall pass if the time is greater than 2 minutes. If the manhole fails the initial test, necessary repairs shall be made with a non-shrink grout while the vacuum is still being drawn. If the manhole fails a second time, repairs should again be made and the manhole shall be tested by means of a hydrostatic test which complies with Section 217.58(b)(1) of the TCEQ's rules. If any manhole fails the hydrostatic test, after failing the vacuum test twice, the contractor should consider replacing that manhole. If the contractor chooses to attempt to repair that manhole, the manhole must be retested by means of the hydrostatic test outlined in Section 217.58(b)(1) of the TCEQ's rules, until it passes.

- 26. Inspection must be provided during critical phases of construction by a qualified inspector under the direction of a P.E. Critical phases of construction are deemed at a minimum to include testing of pipe and manholes for leakage, testing of flexible pipe for installed deflection, and any other as directed by the City. The City and design engineer shall provide inspection as appropriate.

- 27. TCEQ approval letters for plans and specifications review contain the requirement that once the project is completed, a P.E. registered in the state of Texas must certify that the construction was performed substantially in accordance with the approved plans and specifications. If flexible pipe was installed, a P.E. must also certify that all pipe was subjected to and passed the required deflection test. The design engineer, with concurrence of the City, will certify the installation.

- 28. The project plans and specifications must ensure that the pipe installation will adhere to the minimum separation distances allowed by 217.53 (d), TCEQ's rules.

Separation Distances.  
The following rules apply to separation distances between potable water and wastewater treatment plants, and waterlines and sanitary sewers.

- (a) Water line/new sewer line separation. When new sanitary sewers are installed, they shall be installed no closer to waterlines than nine feet in all directions. Sewers that parallel waterlines must be installed in separate trenches. Where the nine foot separation distance cannot be achieved, the following guidelines will apply:
  - (b) SDF

- (1) Where a sanitary sewer parallels a waterline, the sewer shall be constructed of cast iron, ductile iron or PVC meeting ASTM specifications with a pressure rating for both the pipe and joints of 150 psi. The vertical separation shall be a minimum of two feet between outside diameters and the horizontal separation shall be a minimum of four feet between outside diameters. The sewer shall be located below the waterline.
- (2) Where a sanitary sewer crosses a waterline and the sewer is constructed of cast iron, ductile iron or PVC with a minimum pressure rating of 150 psi, an absolute minimum distance of 6 inches between outside diameters shall be maintained. In addition the sewer shall be located below the waterline where possible and one length of the sewer pipe must be centered on the waterline.
- (3) Where a sewer crosses under a waterline and the sewer is constructed of ABS truss pipe, similar semi-rigid plastic composite pipe, clay pipe or concrete pipe with gasketed joints, a minimum two foot separation distance shall be maintained. The initial backfill shall be cement stabilized sand (two or more bags of cement per cubic yard of sand) for all sections of sewer within nine feet of the waterline. This initial backfill shall be from one quarter diameter below the centerline of the pipe to one pipe diameter (but not less than 12 inches) above the top of the pipe.
- (4) Where a sewer crosses over a waterline all portions of the sewer within nine feet of the waterline shall be constructed of cast iron, ductile iron, or PVC pipe with a pressure rating of at least 150 psi using appropriate adapters. In lieu of this procedure the new conveyance may be encased in a joint of 150 psi pressure class pipe at least 18 feet long and two nominal sizes larger than the new conveyance. The space around the carrier pipe shall be supported at 5 foot intervals with spacers or be filled to the springline with washed sand. The encasement pipe should be centered on the crossing and both ends sealed with cement grout or manufactured seal.

- (a) Water line/manhole separation. Unless sanitary sewer manholes and the connecting sewer can be made watertight and tested for no leakage, they must be installed so as to provide a minimum of nine feet of horizontal clearance from an existing or proposed waterline. Where the nine foot separation distance cannot be achieved, a carrier pipe as described in subsection (a)(4) of this section may be used where appropriate.

The separation distance between any unknown water lines which are discovered during the installation phase of the project, and, the gravity sanitary sewer pipe which will be installed, shall be sufficient to comply with the minimum separation distances allowed by 217.53(d) of the TCEQ's rules as stated above.

- 29. AN EROSION AND SEDIMENTATION CONTROL PLAN is included with these plans. These provisions are intended to control erosion and sedimentation due to runoff during construction. These provisions must be installed prior to any other construction activities.

- 30. It is the intent of this project that portable ladders be used to access manholes during construction by the Contractor as well as for maintenance purposes after construction is complete by the City.

- 31. It is the intent of this project that personal gas detectors are required for wear by all personnel whose jobs require entering enclosed spaces (such as manholes and lift stations) capable of accumulations of hydrogen sulfide or other harmful gases. It shall be the responsibility of the Contractor to ensure these detectors are provided to the appropriate personnel during the construction of this project. It shall be the responsibility of the City to ensure these detectors are provided to the appropriate personnel during the maintenance of this project after construction.

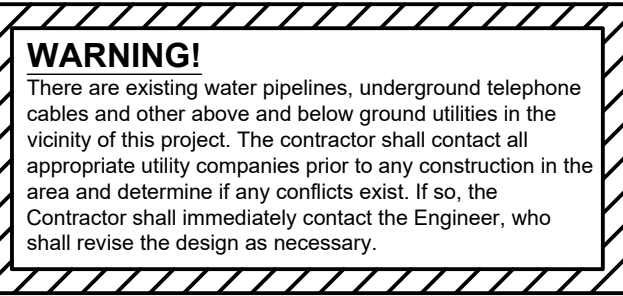

NO.	REVISION	BY	DATE

DESIGNED BY:		DATE	
DRAWN BY:		DATE	
CHECKED BY:		DATE	
APPROVED BY:		DATE	



**STEGER BIZZELL**

ADDRESS: 1978 S. AUSTIN AVENUE, GEORGETOWN, TX 78626  
METRO: 512.930.9412, SERVICES: >>ENGINEERS >>PLANNERS >>SURVEYORS  
TELEPHONE: 512.930.9412, FAX: 512.930.9412, WEBSITE: STEGERBIZZELL.COM

**GENERAL NOTES (2 OF 2)**

**AIRPORT ROAD IMPROVEMENTS**

City of Georgetown  
Williamson County, Texas

Project Number:	22744
SCALE:	AS NOTED
Project Path:	P:\22000-22999\22744
Project Name:	AIRPORT RD. IMPROVEMENTS
Drawing Path:	CAD\Plans
Xref DWG FILE:	
Sheet Number	05 of 28 sheets

These drawings are the sole property of STEGER & BIZZELL ENGINEERING, INC. The use of these drawings is hereby restricted to the original site for which they were prepared. Reproduction or reuse of these drawings in whole or in part without written permission of STEGER & BIZZELL ENGINEERING, INC. is strictly prohibited.

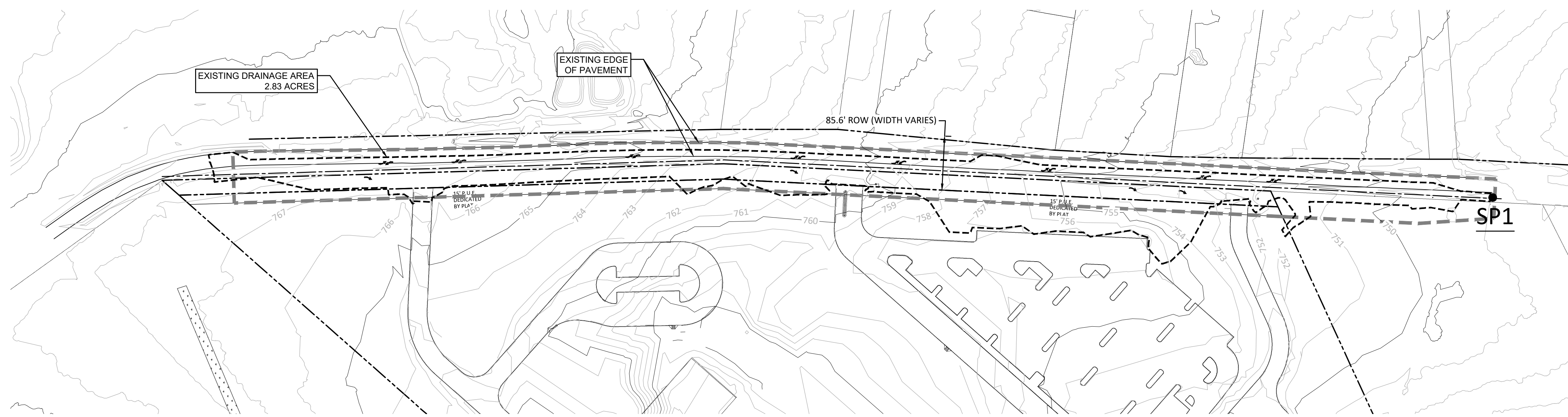

**LEGEND**

- RIGHT-OF-WAY
- PROPOSED CENTERLINE
- EDGE OF PAVEMENT
- EXISTING DRAINAGE BASIN
- 100- EXISTING CONTOURS (MAJOR)
- 100- EXISTING CONTOURS (MINOR)
- LIMITS OF CONSTRUCTION

**EXISTING DRAINAGE CALCULATIONS**

Drainage Basin ID	Area Ac.	C2	C10	C25	C100	Tc (min.)	i2	i10	i25	i100	Q2	Q10	Q25	Q100
SP1	2.831	0.297	0.344	0.386	0.459	15	4.631	6.369	7.402	9.0547	3.9	6.2	8.1	11.8

**WARNING!**  
 There are existing water pipelines, underground telephone cables and other above and below ground utilities in the vicinity of this project. The contractor shall contact all appropriate utility companies prior to any construction in the area and determine if any conflicts exist. If so, the Contractor shall immediately contact the Engineer, who shall revise the design as necessary.

NO.	REVISION	BY	DATE

DESIGNED BY: \_\_\_\_\_ DATE: \_\_\_\_\_

DRAWN BY: \_\_\_\_\_ DATE: \_\_\_\_\_

CHECKED BY: \_\_\_\_\_ DATE: \_\_\_\_\_

APPROVED BY: \_\_\_\_\_ DATE: \_\_\_\_\_



**STEGER BIZZELL**

ADDRESS: 1978 S. AUSTIN AVENUE, GEORGETOWN, TX 78626

METRO: 512.930.9412 | TEXAS REGISTERED ENGINEERING FIRM F-161 | WEB: STEGERBIZZELL.COM

SERVICES: >>ENGINEERS >>PLANNERS >>SURVEYORS

**EXISTING DRAINAGE PLAN**  
**AIRPORT ROAD IMPROVEMENTS**  
 City of Georgetown  
 Williamson County, Texas

Project Number: 22744

SCALE: AS NOTED

Project Path: P:\22000-22999\22744

Project Name: AIRPORT RD. IMPROVEMENTS

Drawing Path: CAD\Plans

Xref DWG FILE: \_\_\_\_\_

Sheet Number: 06 of 28 sheets

These drawings are the sole property of STEGER & BIZZELL ENGINEERING, INC. The use of these drawings is hereby restricted to the original site for which they were prepared. Reproduction or reuse of these drawings in whole or in part without written permission of STEGER & BIZZELL ENGINEERING, INC. is strictly prohibited.

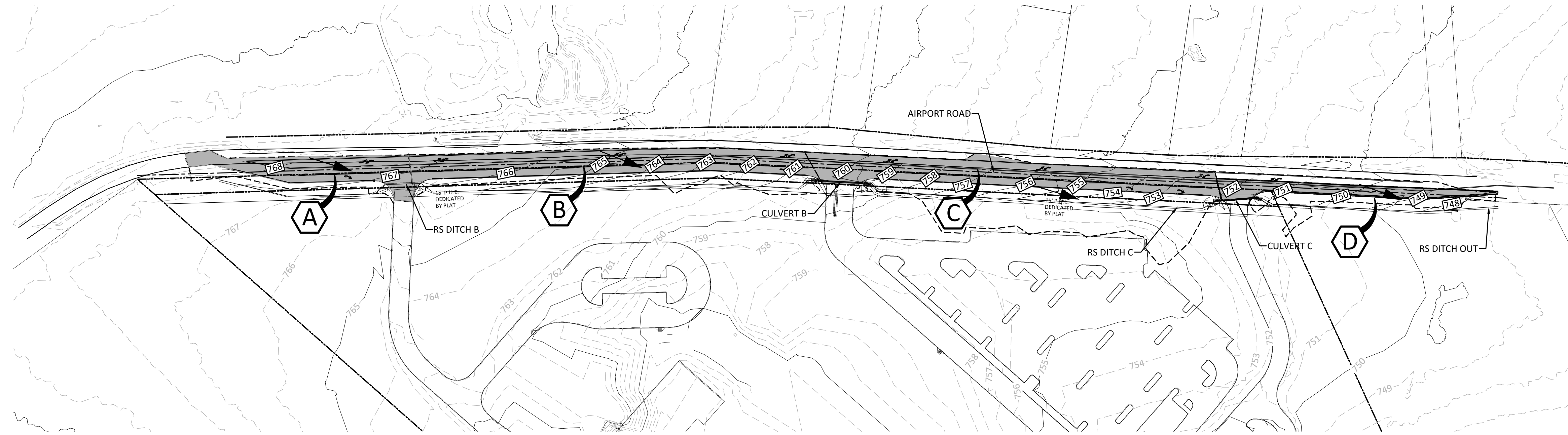

**LEGEND**

- RIGHT-OF-WAY
- FLOW DIRECTION
- - - PROPOSED CENTERLINE
- EDGE OF PAVEMENT
- - - PROPOSED DRAINAGE BASIN
- 100 EXISTING CONTOURS (MAJOR)
- 100 EXISTING CONTOURS (MINOR)
- 100 PROPOSED CONTOURS (MAJOR)
- 100 PROPOSED CONTOURS (MINOR)
- A DRAINAGE AREA DESIGNATION

Drainage Basin ID	Area Ac.	C2	C10	C25	C100	Tc (min.)	i2	i10	i25	i100	Q2	Q10	Q25	Q100
A	0.380	0.613	0.684	0.731	0.817	5	6.479	8.642	9.839	11.88	1.5	2.2	2.7	3.7
Driveway A	0.380	0.613	0.684	0.731	0.817	5	6.479	8.642	9.839	11.88	1.5	2.2	2.7	3.7
B	0.735	0.626	0.698	0.746	0.832	5	6.479	8.642	9.839	11.88	3	4.4	5.4	7.3
Driveway B	1.115	0.621	0.693	0.741	0.827	8	5.827	7.844	8.995	10.909	4	6.1	7.4	10.1
C	1.33	0.626	0.698	0.746	0.832	5	6.479	8.642	9.839	11.88	5.4	8	9.8	13.2
Driveway C	2.445	0.624	0.696	0.744	0.83	12	5.101	6.952	8.036	9.796	7.8	11.8	14.6	19.9
D	0.386	0.626	0.698	0.746	0.832	5	6.479	8.642	9.839	11.88	1.6	2.3	2.8	3.8
SP1	2.831	0.624	0.696	0.744	0.83	15	4.631	6.369	7.402	9.055	8.2	12.6	15.6	21.3

**WARNING!**  
 There are existing water pipelines, underground telephone cables and other above and below ground utilities in the vicinity of this project. The contractor shall contact all appropriate utility companies prior to any construction in the area and determine if any conflicts exist. If so, the Contractor shall immediately contact the Engineer, who shall revise the design as necessary.

NO.	REVISION	BY	DATE

DESIGNED BY: \_\_\_\_\_ DATE \_\_\_\_\_  
 DRAWN BY: \_\_\_\_\_ DATE \_\_\_\_\_  
 CHECKED BY: \_\_\_\_\_ DATE \_\_\_\_\_  
 APPROVED BY: \_\_\_\_\_ DATE \_\_\_\_\_



ADDRESS 1978 S. AUSTIN AVENUE GEORGETOWN, TX 78626  
 METRO 512.930.9412 TEXAS REGISTERED ENGINEERING FIRM F-161 WEB STEGERBIZZELL.COM  
 SERVICES TBPLS FIRM No. 10003700  
 >>ENGINEERS >>PLANNERS >>SURVEYORS

**DEVELOPED DRAINAGE PLAN**  
**AIRPORT ROAD IMPROVEMENTS**  
 City of Georgetown  
 Williamson County, Texas

Project Number: 22744  
 SCALE: AS NOTED  
 Project Path: P:\22000-22999\22744  
 Project Name: AIRPORT RD. IMPROVEMENTS  
 Drawing Path: CAD\Plans  
 Xref DWG FILE:  
 Sheet Number: 07 of 28 sheets

These drawings are the sole property of STEGER & BIZZELL ENGINEERING, INC. The use of these drawings is hereby restricted to the original site for which they were prepared. Reproduction or reuse of these drawings in whole or in part without written permission of STEGER & BIZZELL ENGINEERING, INC. is strictly prohibited.

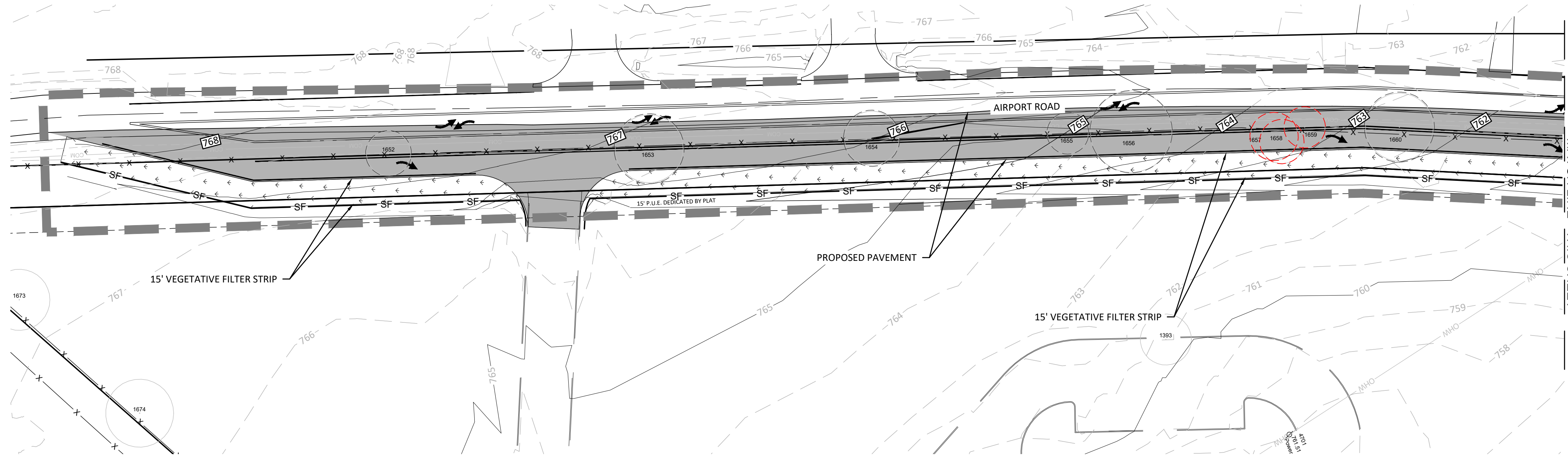

**LEGEND**

- = HERITAGE/PROTECTED TREE TO BE REMOVED
- = OTHER TREE TO BE REMOVED
- = SILT FENCE
- = LIMITS OF CONSTRUCTION
- = VEGETATIVE FILTER STRIPS
- = PROPERTY BOUNDARY
- = EXISTING FENCE TO BE REMOVED WITHIN LIMITS OF CONSTRUCTION

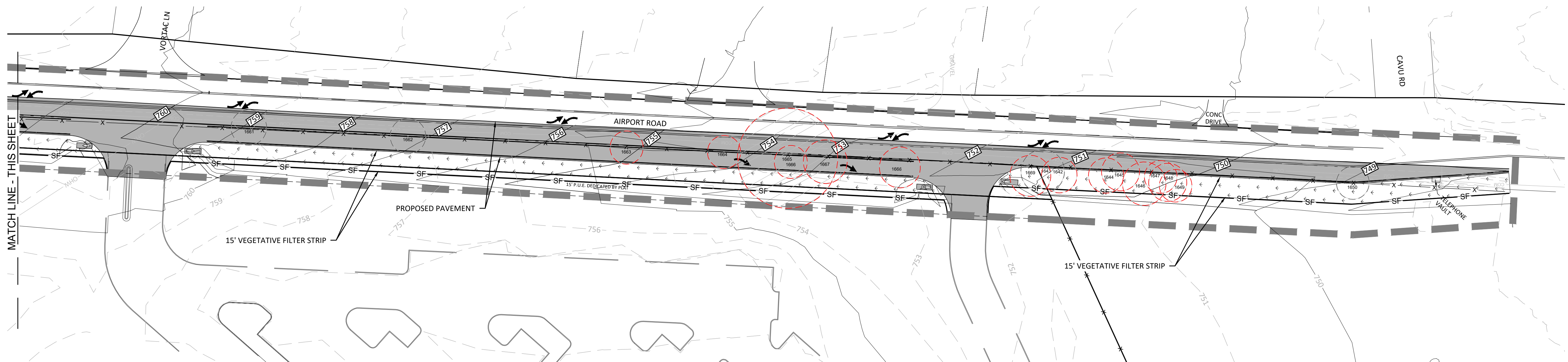

**WARNING!**  
There are existing water pipelines, underground telephone cables and other above and below ground utilities in the vicinity of this project. The contractor shall contact all appropriate utility companies prior to any construction in the area and determine if any conflicts exist. If so, the Contractor shall immediately contact the Engineer, who shall revise the design as necessary.

NO.	REVISION	BY	DATE

DESIGNED BY: \_\_\_\_\_ DATE: \_\_\_\_\_  
 DRAWN BY: \_\_\_\_\_ DATE: \_\_\_\_\_  
 CHECKED BY: \_\_\_\_\_ DATE: \_\_\_\_\_  
 APPROVED BY: \_\_\_\_\_ DATE: \_\_\_\_\_



**STEGER BIZZELL**

1978 S. AUSTIN AVENUE GEORGETOWN, TX 78626  
 ADDRESS  
 METRO 512.930.9412 TEXAS REGISTERED ENGINEERING FIRM F-181 WEB STEGERBIZZELL.COM  
 SERVICES >>ENGINEERS >>PLANNERS >>SURVEYORS

**EROSION & SEDIMENTATION CONTROL PLAN**  
**AIRPORT ROAD IMPROVEMENTS**  
 City of Georgetown  
 Williamson County, Texas

Project Number:	22744
SCALE:	AS NOTED
Project Path:	P:\22000-22999\22744
Project Name:	AIRPORT RD. IMPROVEMENTS
Drawing Path:	CAD\Plans
Xref DWG FILE:	
Sheet Number:	08 of 28 sheets

These drawings are the sole property of STEGER & BIZZELL ENGINEERING, INC. The use of these drawings is hereby restricted to the original site for which they were prepared. Reproduction or reuse of these drawings in whole or in part without written permission of STEGER & BIZZELL ENGINEERING, INC. is strictly prohibited.

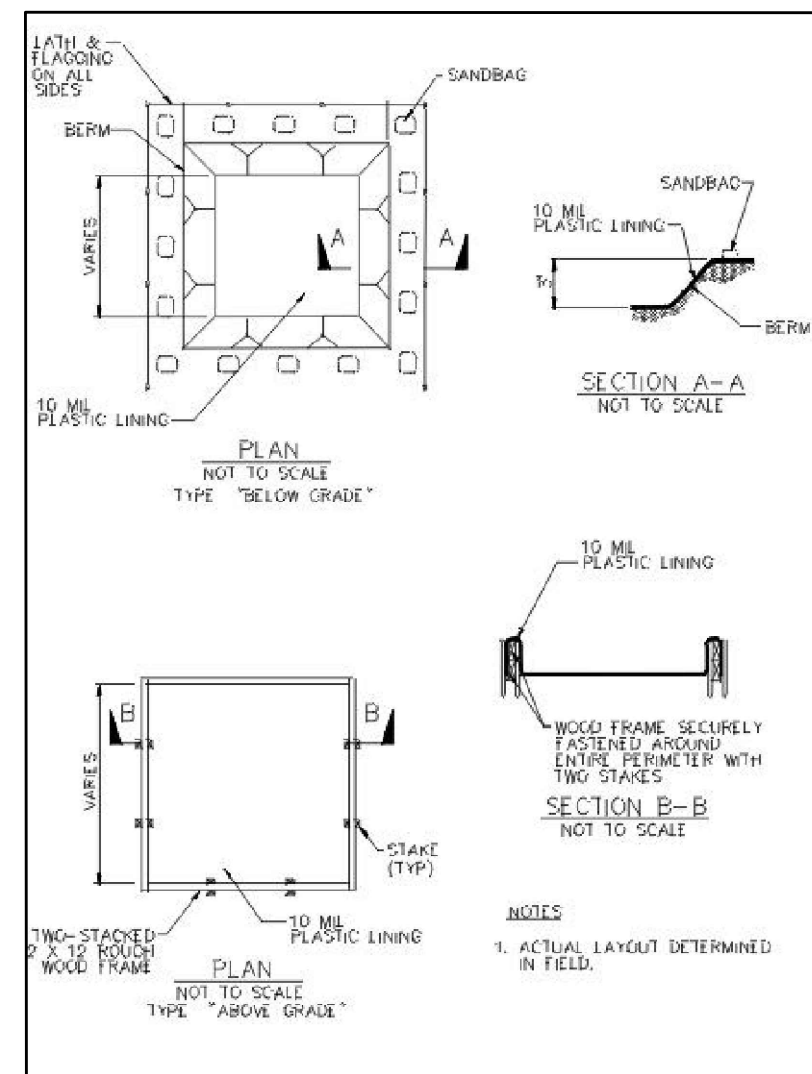

Temporary Concrete Washout Area Detail

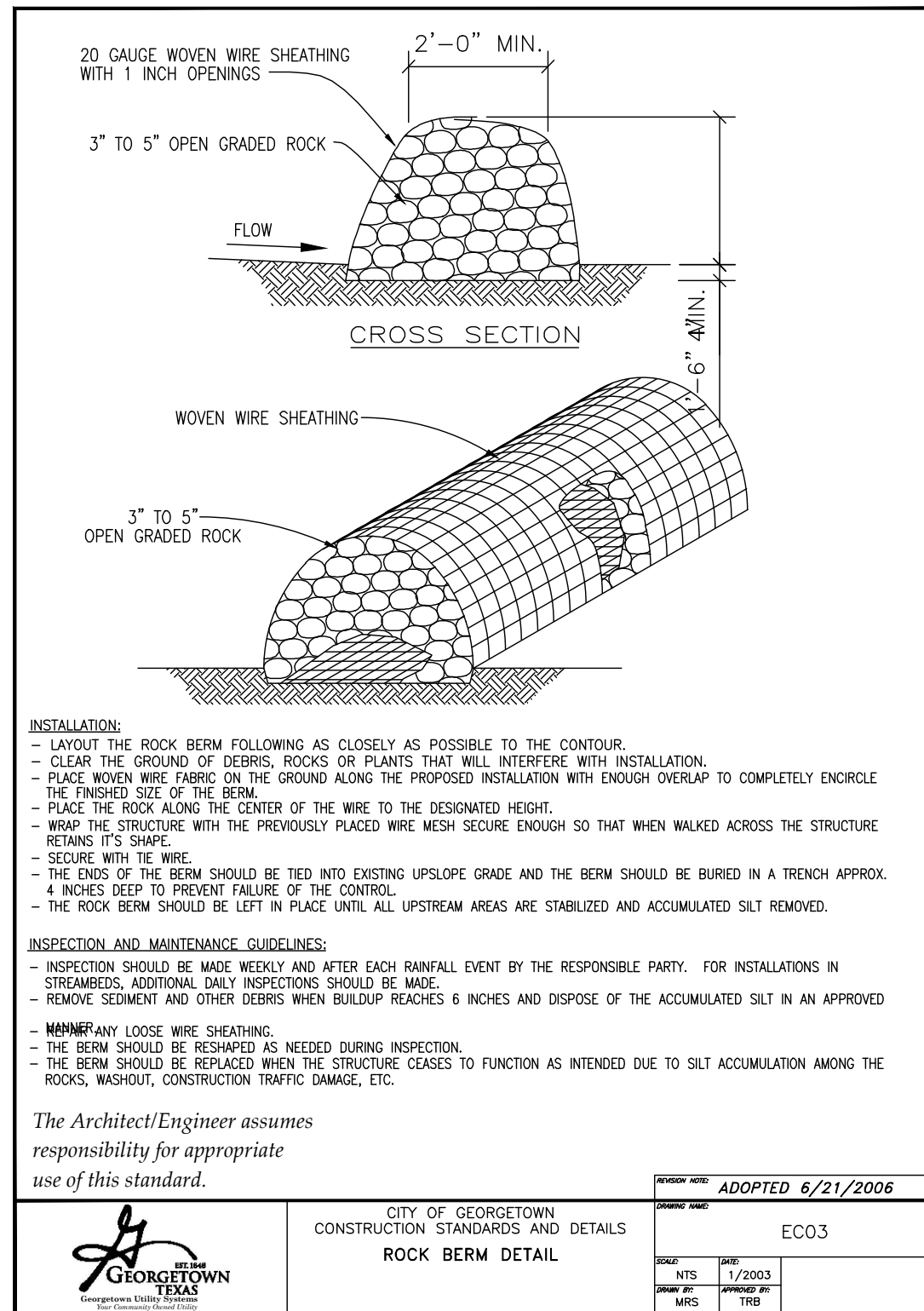

The Architect/Engineer assumes responsibility for appropriate use of this standard.

	CITY OF GEORGETOWN CONSTRUCTION STANDARDS AND DETAILS <b>ROCK BERM DETAIL</b>	ADOPTED 6/21/2006
		ECO3
DATE: 1/2003 DRAWN BY: [Name] CHECKED BY: [Name]	DATE: 1/2003 DRAWN BY: [Name] CHECKED BY: [Name]	DATE: 1/2003 DRAWN BY: [Name] CHECKED BY: [Name]

### GUIDELINES FOR DESIGN AND INSTALLATION OF TEMPORARY EROSION AND SEDIMENTATION CONTROLS

TYPE OF STRUCTURE	REACH LENGTH	MAXIMUM DRAINAGE AREA	SLOPE
SILT FENCE	N/A	2 ACRES	0 - 10%
	200 FEET	2 ACRES	10 - 20%
	100 FEET	1 ACRE	20 - 30%
TRIANGLE FILTER DIKE	100 FEET	1/2 ACRE	< 30% SLOPE
	50 FEET	1/4 ACRE	> 30% SLOPE
ROCK BERM **, **	500 FEET	< 5 ACRES	0 - 10%

\* FOR ROCK BERM DESIGN WHERE PARAMETERS ARE OTHER THAN STATED, DRAINAGE AREA CALCULATIONS AND ROCK BERM DESIGN MUST BE SUBMITTED FOR REVIEW.

\*\* HIGH SERVICE ROCK BERMS MAY BE REQUIRED IN AREAS OF ENVIRONMENTAL SIGNIFICANCE AS DETERMINED BY THE CITY OF GEORGETOWN.

The Architect/Engineer assumes responsibility for appropriate use of this standard.

	CITY OF GEORGETOWN CONSTRUCTION STANDARDS AND DETAILS <b>TEMPORARY EROSION AND SEDIMENTATION CONTROL GUIDELINES</b>	ADOPTED 6/21/2006
		ECO1
DATE: 1/2003 DRAWN BY: [Name] CHECKED BY: [Name]	DATE: 1/2003 DRAWN BY: [Name] CHECKED BY: [Name]	DATE: 1/2003 DRAWN BY: [Name] CHECKED BY: [Name]

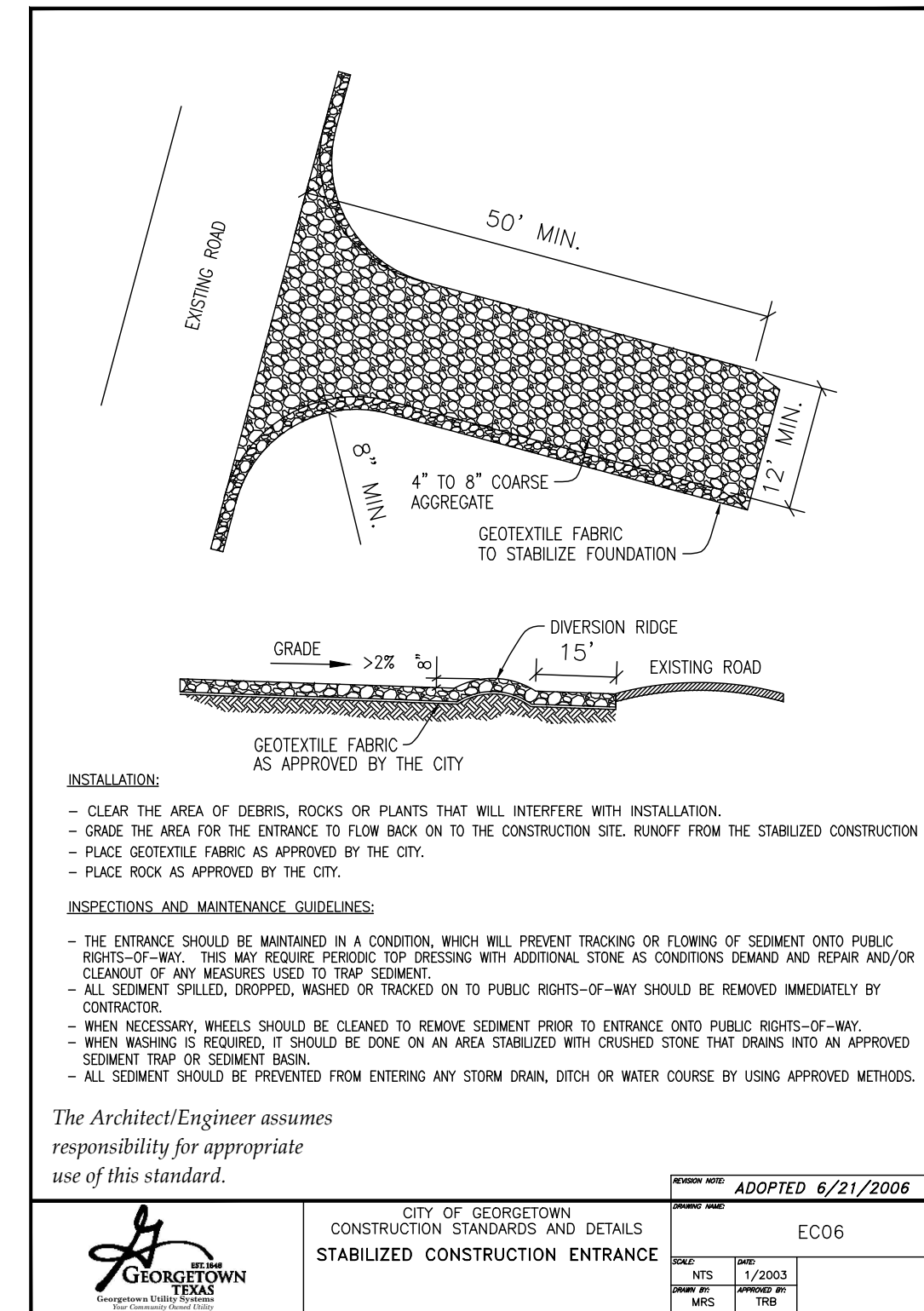

The Architect/Engineer assumes responsibility for appropriate use of this standard.

	CITY OF GEORGETOWN CONSTRUCTION STANDARDS AND DETAILS <b>STABILIZED CONSTRUCTION ENTRANCE</b>	ADOPTED 6/21/2006
		ECO6
DATE: 1/2003 DRAWN BY: [Name] CHECKED BY: [Name]	DATE: 1/2003 DRAWN BY: [Name] CHECKED BY: [Name]	DATE: 1/2003 DRAWN BY: [Name] CHECKED BY: [Name]

NOTE: THIS SECTION IS INTENDED TO ASSIST THOSE PERSONS PREPARING WATER POLLUTION ABATEMENT PLANS (WPAP) OR STORM WATER POLLUTION PREVENTION PLANS (SWPPP) THAT COMPLY WITH FEDERAL, STATE AND/OR LOCAL STORM WATER REGULATIONS.

- THE CONTRACTOR TO INSTALL AND MAINTAIN EROSION/SEDIMENTATION CONTROLS AND TREE/NATURAL AREA PROTECTIVE FENCING PRIOR TO ANY SITE PREPARATION WORK (CLEARING, GRUBBING, GRADING, OR EXCAVATION). CONTRACTOR TO REMOVE EROSION/SEDIMENTATION CONTROLS AT THE COMPLETION OF PROJECT AND GRASS RESTORATION.
- ALL PROJECTS WITHIN THE RECHARGE ZONE OF THE EDWARDS AQUIFER SHALL SUBMIT A BEST MANAGEMENT PRACTICES AND WATER POLLUTION ABATEMENT PLAN TO THE INMFC FOR APPROVAL PRIOR TO ANY CONSTRUCTION.
- THE PLACEMENT OF EROSION/SEDIMENTATION CONTROLS TO BE IN ACCORDANCE WITH THE APPROVED EROSION AND SEDIMENTATION CONTROL PLAN AND WATER POLLUTION ABATEMENT PLAN. DEVIATIONS FROM THE APPROVED PLAN MUST BE SUBMITTED TO AND APPROVED BY THE OWNER'S REPRESENTATIVE.
- ALL PLANTING SHALL BE DONE BETWEEN MAY 1 AND SEPTEMBER 15 EXCEPT AS SPECIFICALLY AUTHORIZED IN WRITING. IF PLANTING IS AUTHORIZED TO BE DONE OUTSIDE THE ABOVE SPECIFIED PERIOD, THE SEED SHALL BE PLANTED WITH THE ADDITION OF WINTER RESCUE (VANDUYCK 3) AT A RATE OF 100#/ACRE. GRASS SHALL BE COMMON BERBERIS GRASS, HULLED, MINIMUM SEED LIFE SEED. GRASS SEED SHALL BE FREE FROM NOXIOUS WEED SEEDS. SEED SHALL BE FURNISHED IN SEALED, RECYCLED AND TREATED WITH APPROPRIATE FUNGICIDE AT THE TIME OF MOUND. SEED SHALL BE FURNISHED IN SEALED, STANDARD CONTAINERS WITH DEALER'S GUARANTEED ANALYSIS.
- ALL DISTURBED AREAS TO BE RESTORED AS NOTED IN THE WATER POLLUTION ABATEMENT PLAN.
- THE PLANTED AREA TO BE BROADCAST OR SPRIKLED IN A MANNER THAT WILL NOT ERODE THE TOPSOIL, BUT WILL SUFFICIENTLY SOAK THE SOIL TO A DEPTH OF FOUR (4) INCHES. THE IRRIGATION TO OCCUR AT 10-DAY INTERVALS DURING THE FIRST TWO MONTHS TO INSURE GERMINATION AND ESTABLISHMENT OF THE GRASS. RAINFALL OCCURRENCES OF 1/2 INCH OR GREATER TO POSTPONE THE WATERING SCHEDULE ONE WEEK.
- RESTORATION TO BE ACCEPTABLE WHEN THE GRASS HAS GROWN AT LEAST 1-1/2 INCHES HIGH WITH 85% COVERAGE. PROVIDED NO BARE SPOTS LARGER THAN 25 SQUARE FEET EXIST.
- A MINIMUM OF FOUR (4) INCHES OF TOPSOIL TO BE PLACED IN ALL AREAS DISTURBED BY CONSTRUCTION.
- THE CONTRACTOR TO HYDROMULCH OR SOO (AS SHOWN ON PLANS) ALL EXPOSED CUTS AND FILLS UPON COMPLETION OF CONSTRUCTION.
- EROSION AND SEDIMENTATION CONTROLS TO BE INSTALLED OR MAINTAINED IN A MANNER WHICH DOES NOT RESULT IN SOIL BUILDUP WITHIN TREE DRIFLINE.
- TO AVOID SOIL COMPACTION, CONTRACTOR SHALL NOT ALLOW VEHICULAR TRAFFIC, PARKING, OR STORAGE OF EQUIPMENT OR MATERIALS IN THE TREE DRIFLINE AREAS.
- WHERE A FENCE IS CLOSER THAN FOUR (4) FEET TO A TREE TRUNK, PROTECT THE TRUNK WITH STRAPPED-ON PLANKING TO A HEIGHT OF EIGHT (8) FEET (OR TO THE LIMITS OF LOWER BRANCHING) IN ADDITION TO THE FENCING.
- TREES TO BE REMOVED IN A MANNER WHICH DOES NOT IMPACT TREES TO BE PRESERVED.
- ANY ROOT EXPOSED BY CONSTRUCTION ACTIVITY TO BE PRUNED FLUSH WITH THE SOIL. BACKFILL ROOT AREAS WITH GOOD QUALITY TOPSOIL AS SOON AS POSSIBLE. IF EXPOSED ROOT AREAS ARE NOT BACKFILLED WITH TWO DAYS, COVER THEM WITH ORGANIC MATERIAL IN A MANNER WHICH REDUCES SOIL TEMPERATURE AND MINIMIZES WATER LOSS DUE TO EVAPORATION.
- CONTRACTOR TO PRUNE VEGETATION TO PROVIDE CLEARANCE FOR STRUCTURES, VEHICULAR TRAFFIC, AND EQUIPMENT BEFORE DAMAGE OCCURS (TRIPPING OF BRANCHES, ETC.). ALL FINISHED PRUNING TO BE DONE ACCORDING TO RECOGNIZED APPROVED STANDARDS OF THE INDUSTRY (REFERENCE THE NATIONAL ARBORIST ASSOCIATION PRUNING STANDARDS FOR SHADE TREES).
- THE CONTRACTOR IS TO INSPECT THE CONTROLS AT WEEKLY INTERVALS AND AFTER EVERY RAINFALL EXCEEDING 1/4 INCH TO VERIFY THAT THEY HAVE NOT BEEN SIGNIFICANTLY DISTURBED. ANY ACCUMULATED SEDIMENT AFTER A SIGNIFICANT RAINFALL TO BE REMOVED AND PLACED IN THE OWNER DESIGNATED SPILL DISPOSAL SITE. THE CONTRACTOR TO CONDUCT PERIODIC INSPECTIONS OF ALL EROSION/SEDIMENTATION CONTROLS AND TO MAKE ANY REPAIRS OR MODIFICATIONS NECESSARY TO ASSURE CONTINUED EFFECTIVE OPERATION OF EACH DEVICE.
- WHERE THERE IS TO BE AN APPROVED GRADE CHANGE, IMPERMEABLE PAVING SURFACE, TREE WELL, OR OTHER SUCH DEVELOPMENT IMMEDIATELY ADJACENT TO A PROTECTED TREE, ERECT THE FENCE APPROXIMATELY TWO TO FOUR FEET (2'-4') BEHIND THE AREA IN QUESTION.
- NO ABOVE AND/OR BELOW GROUND TEMPORARY FUEL STORAGE FACILITIES TO BE STORED ON THE PROJECT SITE.
- IF EROSION AND SEDIMENTATION CONTROL SYSTEMS ARE EXISTING FROM PRIOR CONTRACTS, OWNER'S REPRESENTATIVE AND THE CONTRACTOR TO EXAMINE THE EXISTING EROSION AND SEDIMENTATION CONTROL SYSTEMS FOR DAMAGE PRIOR TO CONSTRUCTION. ANY DAMAGE TO PREEXISTING EROSION AND SEDIMENTATION CONTROLS NOTED TO BE REPAIRED AT OWNERS EXPENSE.
- INTENTIONAL RELEASE OF VEHICLE OR EQUIPMENT FLUIDS ONTO THE GROUND IS NOT ALLOWED. CONTAMINATED SOIL RESULTING FROM ACCIDENTAL SPILL TO BE REMOVED AND DISPOSED OF PROPERLY.

The Architect/Engineer assumes responsibility for appropriate use of this standard.

	CITY OF GEORGETOWN CONSTRUCTION STANDARDS AND DETAILS <b>EROSION AND SEDIMENTATION AND TREE PROTECTION NOTES</b>	ADOPTED 6/21/2006
		ECO1A
DATE: 1/2003 DRAWN BY: [Name] CHECKED BY: [Name]	DATE: 1/2003 DRAWN BY: [Name] CHECKED BY: [Name]	DATE: 1/2003 DRAWN BY: [Name] CHECKED BY: [Name]

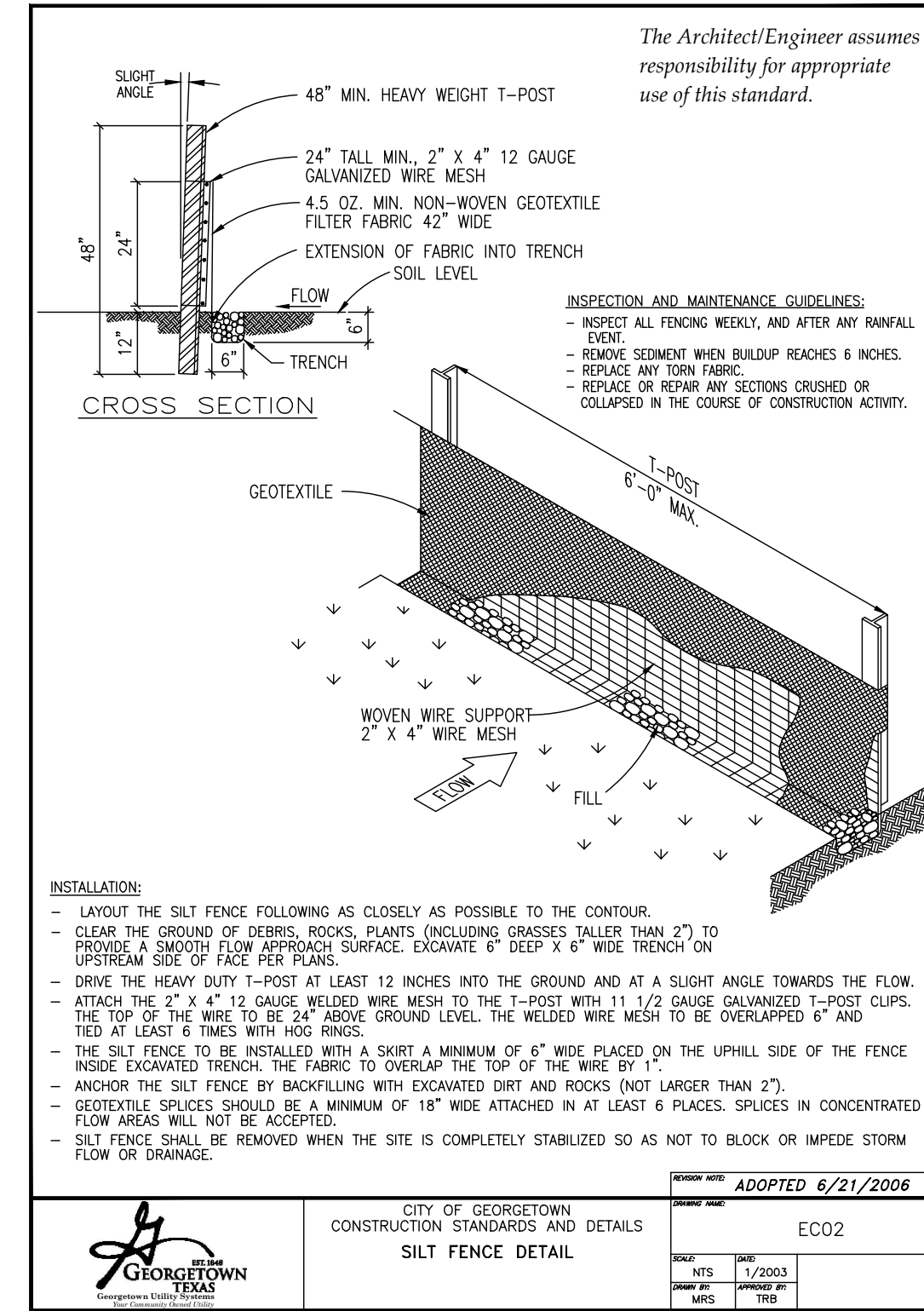

The Architect/Engineer assumes responsibility for appropriate use of this standard.

INSPECTION AND MAINTENANCE GUIDELINES:

- INSPECT ALL FENCING WEEKLY, AND AFTER ANY RAINFALL EVENT.
- REMOVE SEDIMENT WHEN BUILDUP REACHES 6 INCHES.
- REPLACE ANY TORN FABRIC.
- REPLACE OR REPAIR ANY SECTIONS CRUSHED OR COLLAPSED IN THE COURSE OF CONSTRUCTION ACTIVITY.

INSTALLATION:

- LAYOUT THE SILT FENCE FOLLOWING AS CLOSELY AS POSSIBLE TO THE CONTOUR.
- CLEAR THE GROUND OF DEBRIS, ROCKS, PLANTS (INCLUDING GRASSES TALLER THAN 2") TO PROVIDE A SMOOTH FLOW APPROACH SURFACE. EXCAVATE 6" DEEP X 6" WIDE TRENCH ON UPSTREAM SIDE OF FACE PER PLANS.
- DRIVE THE HEAVY DUTY T-POST AT LEAST 12 INCHES INTO THE GROUND AND AT A SLIGHT ANGLE TOWARDS THE FLOW.
- ATTACH THE 2" X 4" 12 GAUGE WELDED WIRE MESH TO THE T-POST WITH 11 1/2 GAUGE GALVANIZED T-POST CLIPS.
- THE TOP OF THE WIRE TO BE 24" ABOVE GROUND LEVEL. THE WELDED WIRE MESH TO BE OVERLAPPED 6" AND TIED AT LEAST 6 TIMES WITH HOG RINGS.
- THE SILT FENCE TO BE INSTALLED WITH A SKIRT A MINIMUM OF 6" WIDE PLACED ON THE UPFILL SIDE OF THE FENCE INSIDE EXCAVATED TRENCH. THE FABRIC TO OVERLAP THE TOP OF THE WIRE BY 1'.
- ANCHOR THE SILT FENCE BY BACKFILLING WITH EXCAVATED DIRT AND ROCKS (NOT LARGER THAN 2").
- GEOTEXTILE SKIRTS SHOULD BE A MINIMUM OF 18" WIDE ATTACHED BY AT LEAST 6 PLACES. SPLICES IN CONCENTRATED FLOW AREAS WILL NOT BE ACCEPTED.
- SILT FENCE SHALL BE REMOVED WHEN THE SITE IS COMPLETELY STABILIZED SO AS NOT TO BLOCK OR IMPEDE STORM FLOW OR DRAINAGE.

The Architect/Engineer assumes responsibility for appropriate use of this standard.

	CITY OF GEORGETOWN CONSTRUCTION STANDARDS AND DETAILS <b>SILT FENCE DETAIL</b>	ADOPTED 6/21/2006
		ECO2
DATE: 1/2003 DRAWN BY: [Name] CHECKED BY: [Name]	DATE: 1/2003 DRAWN BY: [Name] CHECKED BY: [Name]	DATE: 1/2003 DRAWN BY: [Name] CHECKED BY: [Name]

**WARNING!**  
There are existing water pipelines, underground telephone cables and other above and below ground utilities in the vicinity of this project. The contractor shall contact all appropriate utility companies prior to any construction in the area and determine if any conflicts exist. If so, the Contractor shall immediately contact the Engineer, who shall revise the design as necessary.

NO.	REVISION	BY	DATE

DESIGNED BY: \_\_\_\_\_ DATE: \_\_\_\_\_  
 DRAWN BY: \_\_\_\_\_ DATE: \_\_\_\_\_  
 CHECKED BY: \_\_\_\_\_ DATE: \_\_\_\_\_  
 APPROVED BY: \_\_\_\_\_ DATE: \_\_\_\_\_



ADDRESS: 1978 S. AUSTIN AVENUE, GEORGETOWN, TX 78626  
 METRO: 512.930.9412, SERVICES: >>ENGINEERS >>PLANNERS >>SURVEYORS  
 TEXAS REGISTERED ENGINEERING FIRM F-181, TBPLS FIRM No. 10003700, WEB: STEGERBIZZELL.COM

## EROSION & SEDIMENTATION CONTROL DETAILS

### AIRPORT ROAD IMPROVEMENTS

City of Georgetown  
Williamson County, Texas

Project Number:	22744
SCALE:	AS NOTED
Project Path:	P:\22000-22999\22744
Project Name:	AIRPORT RD. IMPROVEMENTS
Drawing Path:	CAD\Plans
Xref DWG FILE:	
Sheet Number:	09 of 28 sheets

These drawings are the sole property of STEGER & BIZZELL ENGINEERING, INC. The use of these drawings is hereby restricted to the original site for which they were prepared. Reproduction or reuse of these drawings in whole or in part without written permission of STEGER & BIZZELL ENGINEERING, INC. is strictly prohibited.

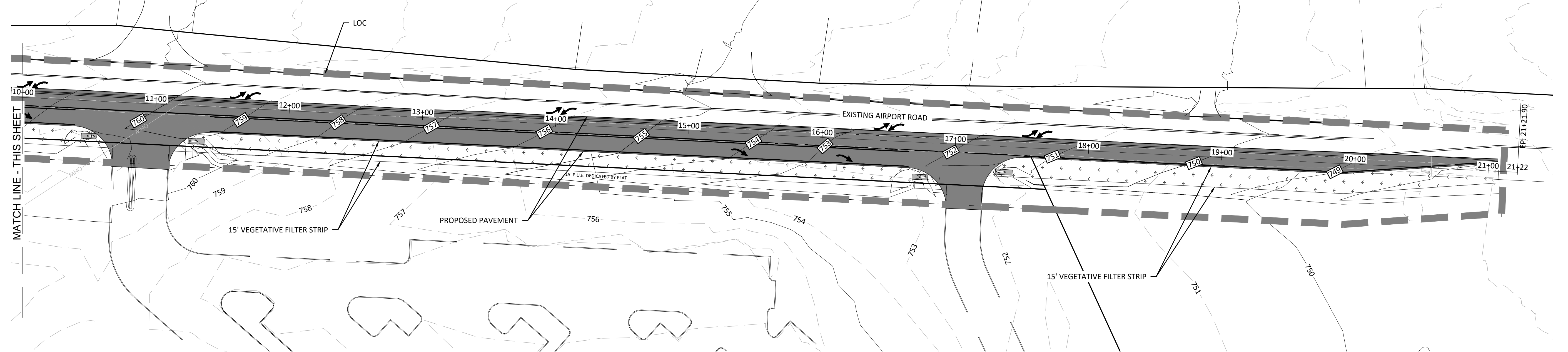
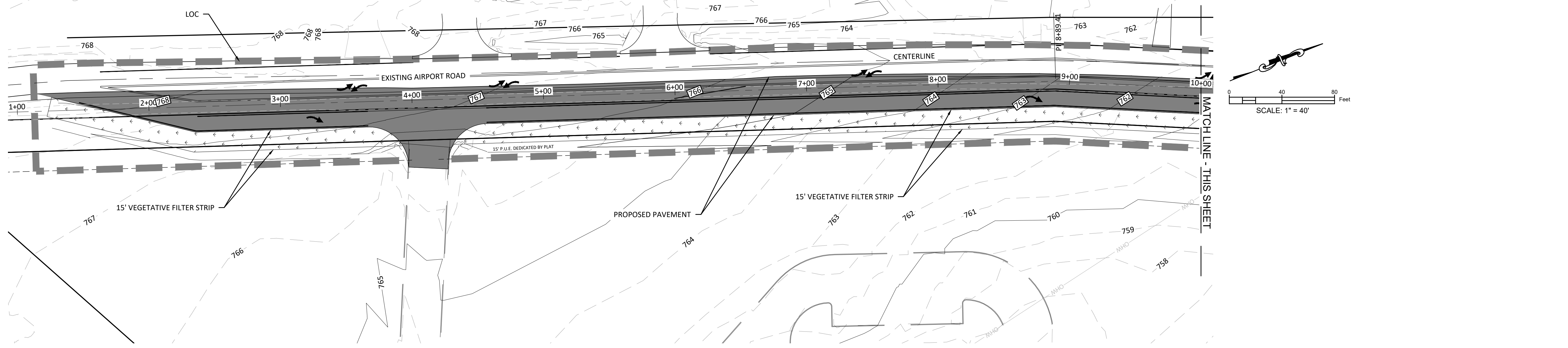

**NOTE:**

- CONTRACTOR SHALL SEED THE VEGETATED FILTER STRIP ACCORDING TO TXDOT STANDARD SPECIFICATIONS SECTION 164 - SEEDING FOR EROSION CONTROL. CONTRACTOR SHALL USE SEED MIXES APPROPRIATE FOR THE AUSTIN DISTRICT AND APPROPRIATE TO THE SEASON DURING WHICH CONSTRUCTION TAKES PLACE.

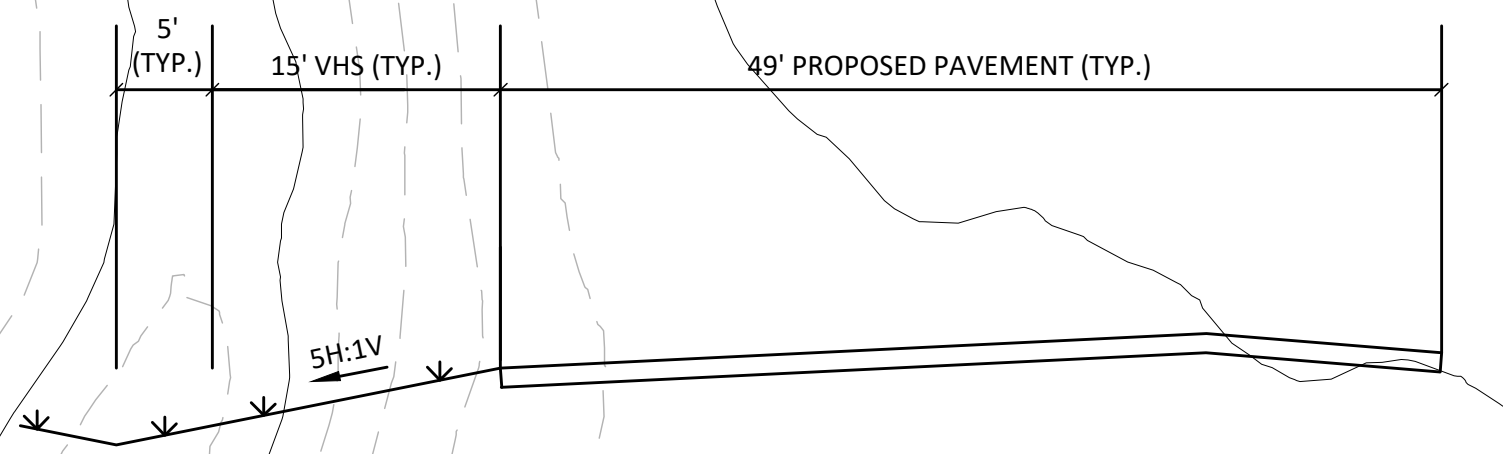

**VEGETATED FILTER STRIP TYPICAL SECTION**  
1" = 10'

**WARNING!**  
There are existing water pipelines, underground telephone cables and other above and below ground utilities in the vicinity of this project. The contractor shall contact all appropriate utility companies prior to any construction in the area and determine if any conflicts exist. If so, the Contractor shall immediately contact the Engineer, who shall revise the design as necessary.

NO.	REVISION	BY	DATE

DESIGNED BY:	DATE
DRAWN BY:	DATE
CHECKED BY:	DATE
APPROVED BY:	DATE

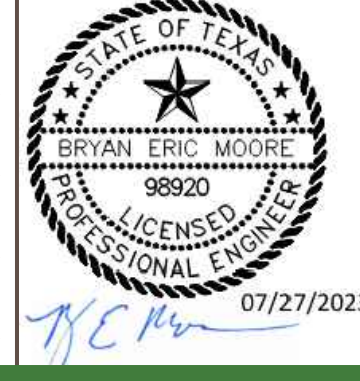

**STEGER BIZZELL**

ADDRESS: 1978 S. AUSTIN AVENUE, GEORGETOWN, TX 78626  
 METRO: 512.930.9412, TEXAS REGISTERED ENGINEERING FIRM F-181, WEB: STEGERBIZZELL.COM  
 SERVICES: >>ENGINEERS >>PLANNERS >>SURVEYORS

**WATER QUALITY PLAN**  
**AIRPORT ROAD IMPROVEMENTS**  
 City of Georgetown  
 Williamson County, Texas

Project Number:	22744
SCALE:	AS NOTED
Project Path:	P:\22000-22999\22744
Project Name:	AIRPORT RD. IMPROVEMENTS
Drawing Path:	CAD\Plans
Xref DWG FILE:	
Sheet Number:	10 of 28 sheets



These drawings are the sole property of STEGER & BIZZELL ENGINEERING, INC. The use of these drawings is hereby restricted to the original site for which they were prepared. Reproduction or reuse of these drawings in whole or in part without written permission of STEGER & BIZZELL ENGINEERING, INC. is strictly prohibited.

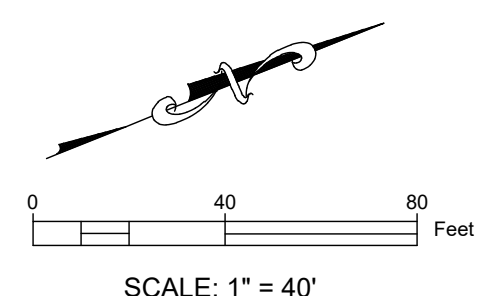
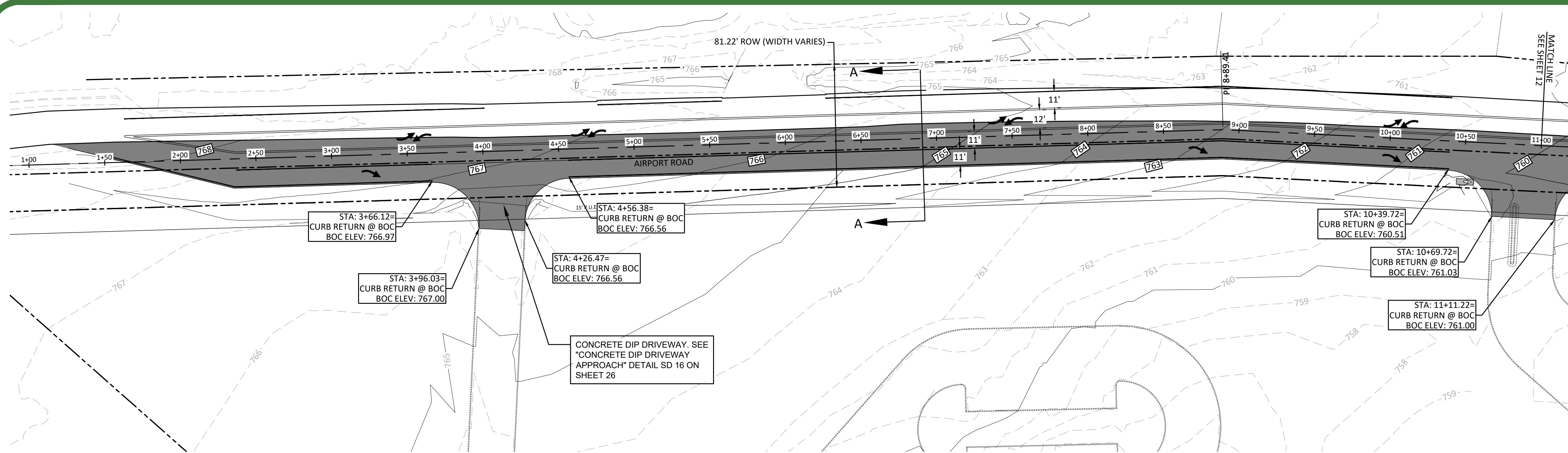

**LEGEND**

- RIGHT-OF-WAY
- PROPOSED CENTERLINE
- EDGE OF PAVEMENT
- BACK OF CURB
- EXISTING CONTOURS (MAJOR)
- EXISTING CONTOURS (MINOR)
- PROPOSED CONTOURS (MAJOR)
- PROPOSED CONTOURS (MINOR)

- NOTES:**
- UNLESS OTHERWISE MENTIONED, ALL STATIONING AND OFFSETS ARE BASED ON PROPOSED AIRPORT ROAD CENTERLINE.
  - AIRPORT ROAD IS A RESIDENTIAL COLLECTOR WITH A DESIGN SPEED OF 35 MPH.
  - SEE SHEET 26 FOR TYPICAL SECTION DETAILS AND FOR PAVING AND DRAINAGE DETAILS.
  - SEE SHEET 21 TO 23 FOR STRIPING AND SIGNAGE DETAILS, PAVEMENT MARKINGS, AND SIGN MOUNTING DETAILS.

## PROPOSED AIRPORT ROAD

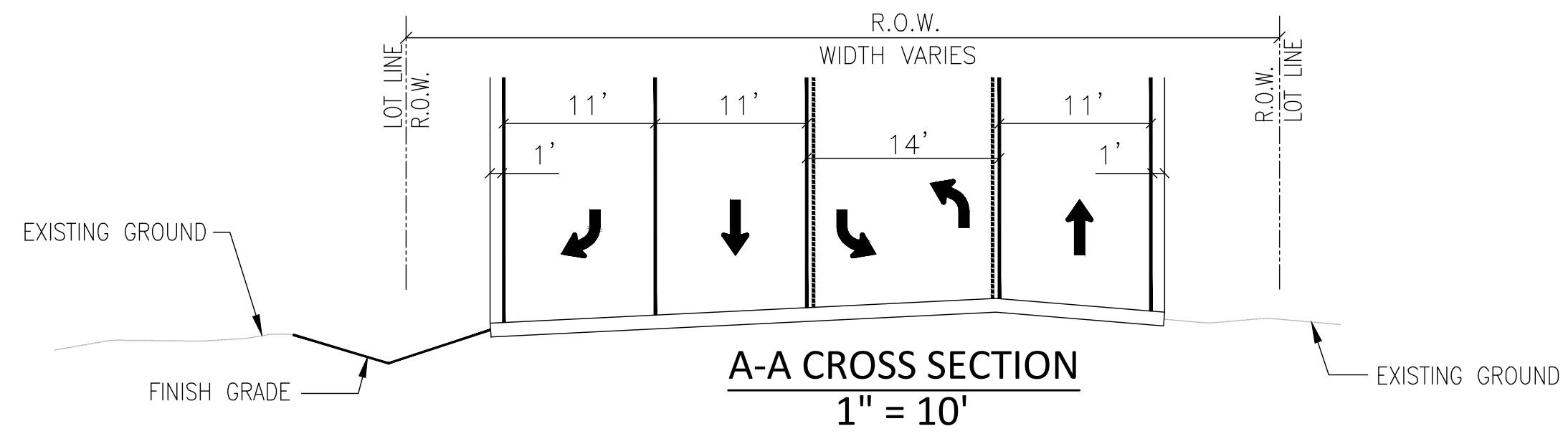
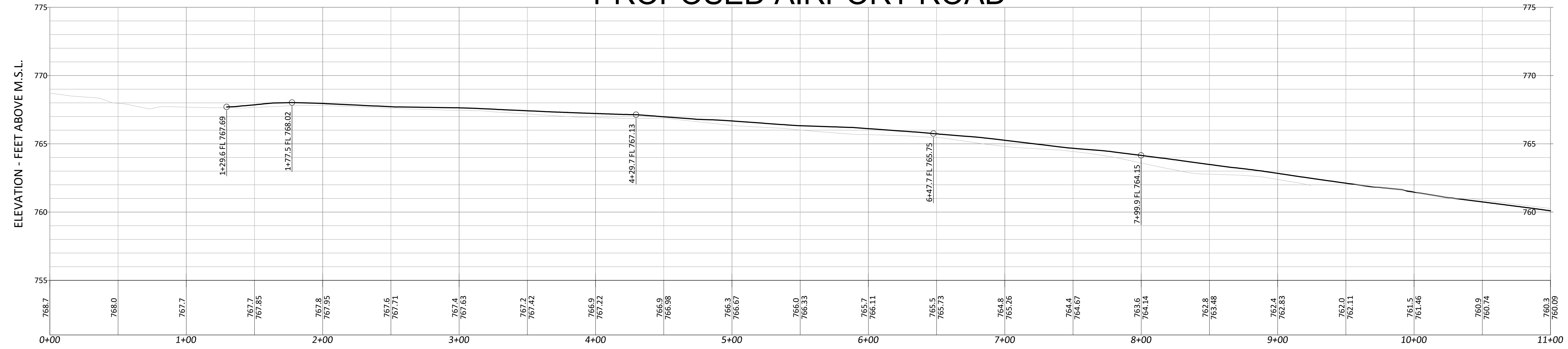

SCALE  
1" = 40' HORIZONTAL  
1" = 4' VERTICAL

**WARNING!**  
There are existing water pipelines, underground telephone cables and other above and below ground utilities in the vicinity of this project. The contractor shall contact all appropriate utility companies prior to any construction in the area and determine if any conflicts exist. If so, the Contractor shall immediately contact the Engineer, who shall revise the design as necessary.

NO.	REVISION	BY	DATE

DESIGNED BY:	DATE:
DRAWN BY:	DATE:
CHECKED BY:	DATE:
APPROVED BY:	DATE:



**STEGER & BIZZELL**

1978 S. AUSTIN AVENUE GEORGETOWN, TX 78626

512.930.9412 TEXAS REGISTERED ENGINEERING FIRM F-181 METRO TBPLS FIRM No. 10003700

STEGERBIZZELL.COM

ENGINEERS PLANNERS SURVEYORS

**AIRPORT ROAD PLAN & PROFILE (1 OF 2)**  
**AIRPORT ROAD IMPROVEMENTS**  
City of Georgetown  
Williamson County, Texas

Project Number:	22744
SCALE:	AS NOTED
Project Path:	P:\22000-22999\22744
Project Name:	AIRPORT RD. IMPROVEMENTS
Drawing Path:	CAD\Plans
Xref DWG FILE:	
Sheet Number:	11 of 28 sheets

These drawings are the sole property of STEGER & BIZZELL ENGINEERING, INC. The use of these drawings is hereby restricted to the original site for which they were prepared. Reproduction or reuse of these drawings in whole or in part without written permission of STEGER & BIZZELL ENGINEERING, INC. is strictly prohibited.

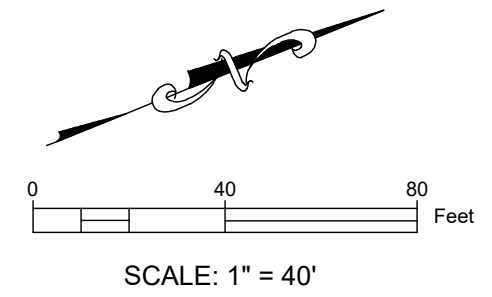
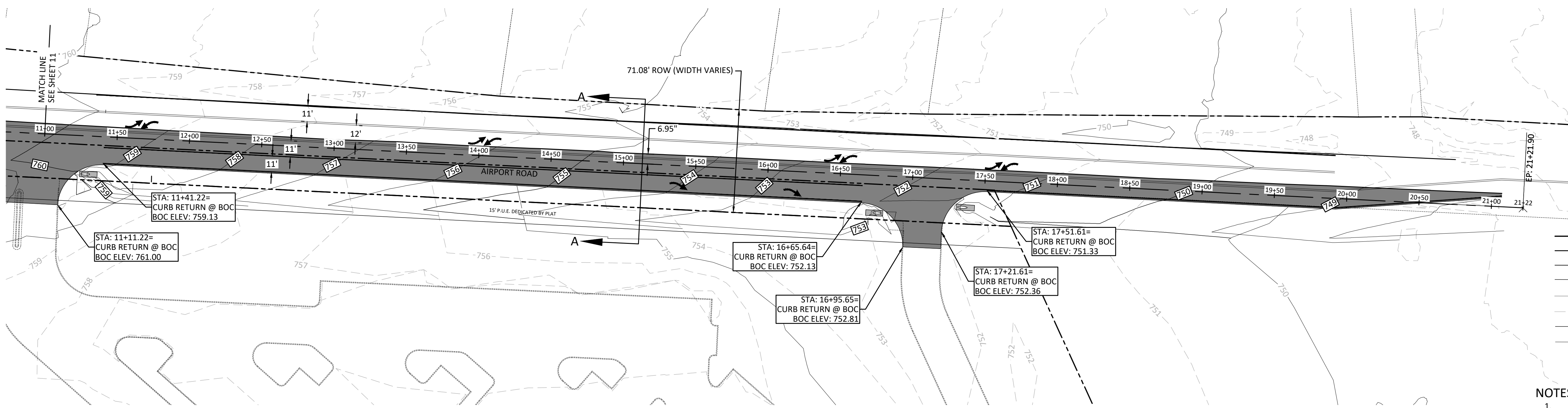

**LEGEND**

- RIGHT-OF-WAY
- PROPOSED CENTERLINE
- EDGE OF PAVEMENT
- BACK OF CURB
- - - 100 EXISTING CONTOURS (MAJOR)
- - - 100 EXISTING CONTOURS (MINOR)
- 100 PROPOSED CONTOURS (MAJOR)
- 100 PROPOSED CONTOURS (MINOR)

- NOTES:**
1. UNLESS OTHERWISE MENTIONED, ALL STATIONING AND OFFSETS ARE BASED ON PROPOSED AIRPORT ROAD CENTERLINE.
  2. AIRPORT ROAD IS A RESIDENTIAL COLLECTOR WITH A DESIGN SPEED OF 35 MPH.
  3. SEE SHEET 26 FOR TYPICAL SECTION DETAILS AND FOR PAVING AND DRAINAGE DETAILS.
  4. SEE SHEET 21 TO 23 FOR STRIPING AND SIGNAGE DETAILS, PAVEMENT MARKINGS, AND SIGN MOUNTING DETAILS.

## PROPOSED AIRPORT ROAD

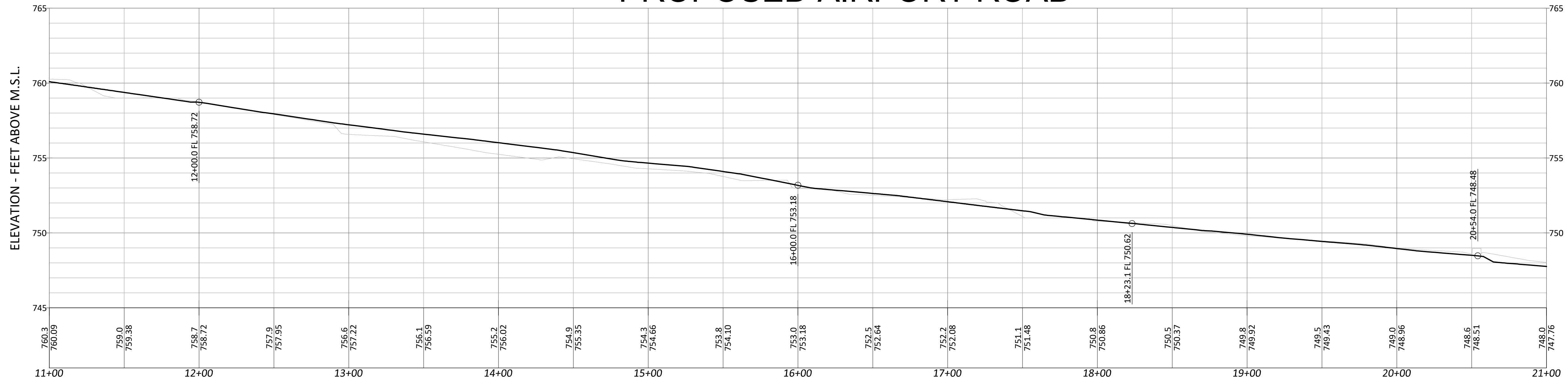

**SCALE**  
1" = 40' HORIZONTAL  
1" = 4' VERTICAL

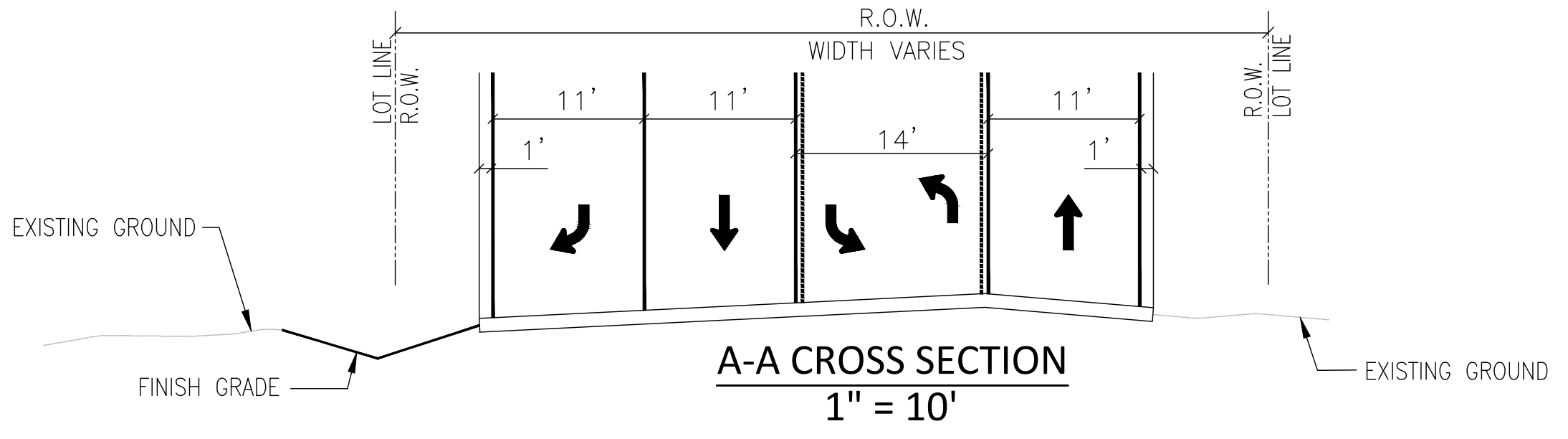

**WARNING!**  
There are existing water pipelines, underground telephone cables and other above and below ground utilities in the vicinity of this project. The contractor shall contact all appropriate utility companies prior to any construction in the area and determine if any conflicts exist. If so, the Contractor shall immediately contact the Engineer, who shall revise the design as necessary.

NO.	REVISION	BY	DATE

DESIGNED BY:	DATE
DRAWN BY:	DATE
CHECKED BY:	DATE
APPROVED BY:	DATE

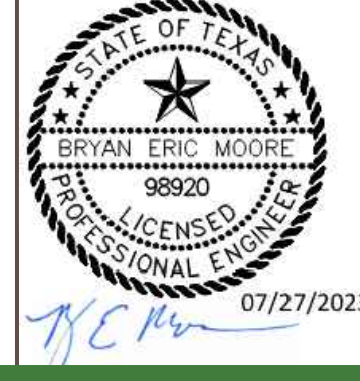

**STEGER & BIZZELL**

1978 S. AUSTIN AVENUE      GEORGETOWN, TX 78626

METRO 512.930.9412      TEXAS REGISTERED ENGINEERING FIRM F-181      WEB STEGERBIZZELL.COM

SERVICES      >>ENGINEERS      >>PLANNERS      >>SURVEYORS

**AIRPORT ROAD PLAN & PROFILE (2 OF 2)**  
**AIRPORT ROAD IMPROVEMENTS**  
City of Georgetown  
Williamson County, Texas

Project Number:	22744
SCALE:	AS NOTED
Project Path:	P:\22000-22999\22744
Project Name:	AIRPORT RD. IMPROVEMENTS
Drawing Path:	CAD\Plans
Xref DWG FILE:	
Sheet Number:	12 of 28 sheets