

CONTRIBUTING ZONE PLAN MODIFICATION APPLICATION

FOR

PEC LIBERTY HILL (PEDERNALES ELECTRIC COOPERATIVE SERVICE CENTER)

10625 W TX-29
Liberty Hill, Texas 78642

Prepared For:

PEDERNALES ELECTRIC COOPERATIVE, INC
201 S. AVENUE F
AUSTIN, TEXAS 78736

P.O. Box 1
Johnson City, Texas 78636 (registered mailing address)

Prepared By:



Sandlin Services, LLC
TBPELS Firm # 21356
P: (806) 679-7303

March 20, 2024

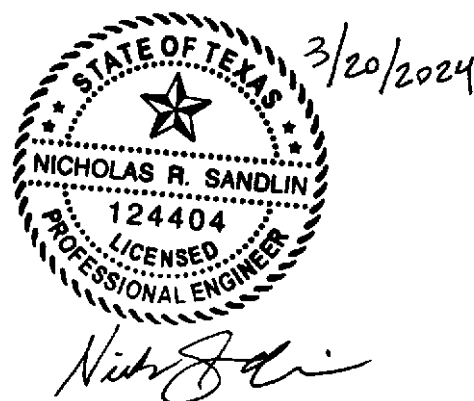



TABLE OF CONTENTS

Edwards Aquifer Application Cover Page (TCEQ-20705)

Modification of a Previously Approved Contributing Zone Plan Form (TCEQ-10259)

Attachment A – Original Approval Letter and Approved Modification Letters

Attachment B – Narrative of Proposed Modification

Attachment C – Current Site Plan of the Approved Project

Contributing Zone Plan Application (TCEQ-10257)

Attachment A – Road Map

Attachment B – USGS Quadrangle Map

Attachment C – Project Narrative

Attachment D – Factors Affecting Surface Water Quality

Attachment E – Volume and Character of Stormwater

Attachment F – Suitability Letter from Authorized Agent (if OSSF is proposed)

Attachment G – Alternative Secondary Containment Methods (if proposed)

Attachment H – AST Containment Structure Drawing (if AST is proposed)

Attachment I – 20% or Less Impervious Cover Declaration (if applicable)

Attachment J – BMPs for Upgradient Stormwater

Attachment K – BMPs for On-site Stormwater

Attachment L – PMTs for Surface Streams

Attachment M – Construction Plans

Attachment N – Inspection, Maintenance, Repair and Retrofit Plan

Attachment O – Pilot-Scale Field Testing Plan, if BMPs not based on Complying with the Edwards Aquifer Rules: Technical Guidance for BMPs

Attachment P – Measures for Minimizing Surface Stream Contamination

SWPPP or Temporary Stormwater Section (TCEQ-0602)

Attachment A – Spill Response Actions

Attachment B – Potential Sources of Contamination

Attachment C – Sequence of Major Activities

Attachment D – Temporary Best Management Practices and Measures

Attachment E – Request to Temporarily Seal a Feature, if sealing a feature

Attachment F – Structural Practices

Attachment G – Drainage Area Map

Attachment H – Temporary Sediment Pond(s) Plans and Calculations

Attachment I – Inspection and maintenance for BMPs

Attachment J – Schedule of Interim and Permanent Soil Stabilization Practices

Copy of Notice of Intent (NOI)

Agent Authorization Form (TCEQ-0599)



PEC Liberty Hill
CONTRIBUTING ZONE PLAN MODIFICATION

Application Fee Form (TCEQ-0574)

Check Payable to the "Texas Commission on Environmental Quality"

Core Data Form (TCEQ-10400)



*PEC Liberty Hill
CONTRIBUTING ZONE PLAN MODIFICATION*

Edwards Aquifer Application Cover Page (TCEQ-20705)

Texas Commission on Environmental Quality

Edwards Aquifer Application Cover Page

Our Review of Your Application

The Edwards Aquifer Program staff conducts an administrative and technical review of all applications. The turnaround time for administrative review can be up to 30 days as outlined in 30 TAC 213.4(e). Generally administrative completeness is determined during the intake meeting or within a few days of receipt. The turnaround time for technical review of an administratively complete Edwards Aquifer application is 90 days as outlined in 30 TAC 213.4(e). Please know that the review and approval time is directly impacted by the quality and completeness of the initial application that is received. In order to conduct a timely review, it is imperative that the information provided in an Edwards Aquifer application include final plans, be accurate, complete, and in compliance with [30 TAC 213](#).

Administrative Review

1. [Edwards Aquifer applications](#) must be deemed administratively complete before a technical review can begin. To be considered administratively complete, the application must contain completed forms and attachments, provide the requested information, and meet all the site plan requirements. The submitted application and plan sheets should be final plans. Please submit one full-size set of plan sheets with the original application, and half-size sets with the additional copies.

To ensure that all applicable documents are included in the application, the program has developed tools to guide you and web pages to provide all forms, checklists, and guidance. Please visit the below website for assistance: <http://www.tceq.texas.gov/field/eapp>.

2. This Edwards Aquifer Application Cover Page form (certified by the applicant or agent) must be included in the application and brought to the administrative review meeting.
3. Administrative reviews are scheduled with program staff who will conduct the review. Applicants or their authorized agent should call the appropriate regional office, according to the county in which the project is located, to schedule a review. The average meeting time is one hour.
4. In the meeting, the application is examined for administrative completeness. Deficiencies will be noted by staff and emailed or faxed to the applicant and authorized agent at the end of the meeting, or shortly after. Administrative deficiencies will cause the application to be deemed incomplete and returned.

An appointment should be made to resubmit the application. The application is re-examined to ensure all deficiencies are resolved. The application will only be deemed administratively complete when all administrative deficiencies are addressed.

5. If an application is received by mail, courier service, or otherwise submitted without a review meeting, the administrative review will be conducted within 30 days. The applicant and agent will be contacted with the results of the administrative review. If the application is found to be administratively incomplete, it can be retrieved from the regional office or returned by regular mail. If returned by mail, the regional office may require arrangements for return shipping.
6. If the geologic assessment was completed before October 1, 2004 and the site contains “possibly sensitive” features, the assessment must be updated in accordance with the *Instructions to Geologists* (TCEQ-0585 Instructions).

Technical Review

1. When an application is deemed administratively complete, the technical review period begins. The regional office will distribute copies of the application to the identified affected city, county, and groundwater conservation district whose jurisdiction includes the subject site. These entities and the public have 30 days to provide comments on the application to the regional office. All comments received are reviewed by TCEQ.
2. A site assessment is usually conducted as part of the technical review, to evaluate the geologic assessment and observe existing site conditions. The site must be accessible to our staff. The site boundaries should be

clearly marked, features identified in the geologic assessment should be flagged, roadways marked and the alignment of the Sewage Collection System and manholes should be staked at the time the application is submitted. If the site is not marked the application may be returned.

3. We evaluate the application for technical completeness and contact the applicant and agent via Notice of Deficiency (NOD) to request additional information and identify technical deficiencies. There are two deficiency response periods available to the applicant. There are 14 days to resolve deficiencies noted in the first NOD. If a second NOD is issued, there is an additional 14 days to resolve deficiencies. If the response to the second notice is not received, is incomplete or inadequate, or provides new information that is incomplete or inadequate, the application must be withdrawn or will be denied. Please note that because the technical review is underway, whether the application is withdrawn or denied **the application fee will be forfeited.**
4. The program has 90 calendar days to complete the technical review of the application. If the application is technically adequate, such that it complies with the Edwards Aquifer rules, and is protective of the Edwards Aquifer during and after construction, an approval letter will be issued. Construction or other regulated activity may not begin until an approval is issued.

Mid-Review Modifications

It is important to have final site plans prior to beginning the permitting process with TCEQ to avoid delays.

Occasionally, circumstances arise where you may have significant design and/or site plan changes after your Edwards Aquifer application has been deemed administratively complete by TCEQ. This is considered a “Mid-Review Modification”. Mid-Review Modifications may require redistribution of an application that includes the proposed modifications for public comment.

If you are proposing a Mid-Review Modification, two options are available:

- If the technical review has begun your application can be denied/withdrawn, your fees will be forfeited, and the plan will have to be resubmitted.
- TCEQ can continue the technical review of the application as it was submitted, and a modification application can be submitted at a later time.

If the application is denied/withdrawn, the resubmitted application will be subject to the administrative and technical review processes and will be treated as a new application. The application will be redistributed to the affected jurisdictions.

Please contact the regional office if you have questions. If your project is located in Williamson, Travis, or Hays County, contact TCEQ’s Austin Regional Office at 512-339-2929. If your project is in Comal, Bexar, Medina, Uvalde, or Kinney County, contact TCEQ’s San Antonio Regional Office at 210-490-3096

Please fill out all required fields below and submit with your application.

1. Regulated Entity Name: PEC Liberty Hill				2. Regulated Entity No.: 105473979					
3. Customer Name: Pedernales Electric Cooperative INC				4. Customer No.: 601327927					
5. Project Type: (Please circle/check one)	New	Modification		Extension	Exception				
6. Plan Type: (Please circle/check one)	WPAP	CZP	SCS	UST	AST	EXP	EXT	Technical Clarification	Optional Enhanced Measures
7. Land Use: (Please circle/check one)	Residential	Non-residential			8. Site (acres):		6.22		
9. Application Fee:	\$5,000		10. Permanent BMP(s):			Existing – no change			
11. SCS (Linear Ft.):	0		12. AST/UST (No. Tanks):			1 - 10,000 gal split (7000/3000)			
13. County:	Williamson		14. Watershed:			South Fork San Gabriel River			

Application Distribution

Instructions: Use the table below to determine the number of applications required. One original and one copy of the application, plus additional copies (as needed) for each affected incorporated city, county, and groundwater conservation district are required. Linear projects or large projects, which cross into multiple jurisdictions, can require additional copies. Refer to the “Texas Groundwater Conservation Districts within the EAPP Boundaries” map found at:

http://www.tceq.texas.gov/assets/public/compliance/field_ops/eapp/EAPP%20GWCD%20map.pdf

For more detailed boundaries, please contact the conservation district directly.

Austin Region			
County:	Hays	Travis	Williamson
Original (1 req.)	—	—	_1_
Region (1 req.)	—	—	_1_
County(ies)	—	—	_1_
Groundwater Conservation District(s)	<input type="checkbox"/> Edwards Aquifer Authority <input type="checkbox"/> Barton Springs/ Edwards Aquifer <input type="checkbox"/> Hays Trinity <input type="checkbox"/> Plum Creek	<input type="checkbox"/> Barton Springs/ Edwards Aquifer	NA
City(ies) Jurisdiction	<input type="checkbox"/> Austin <input type="checkbox"/> Buda <input type="checkbox"/> Dripping Springs <input type="checkbox"/> Kyle <input type="checkbox"/> Mountain City <input type="checkbox"/> San Marcos <input type="checkbox"/> Wimberley <input type="checkbox"/> Woodcreek	<input type="checkbox"/> Austin <input type="checkbox"/> Bee Cave <input type="checkbox"/> Pflugerville <input type="checkbox"/> Rollingwood <input type="checkbox"/> Round Rock <input type="checkbox"/> Sunset Valley <input type="checkbox"/> West Lake Hills	<input type="checkbox"/> Austin <input type="checkbox"/> Cedar Park <input type="checkbox"/> Florence <input type="checkbox"/> Georgetown <input type="checkbox"/> Jerrell <input type="checkbox"/> Leander <input type="checkbox"/> 1_Liberty Hill <input type="checkbox"/> Pflugerville <input type="checkbox"/> Round Rock

San Antonio Region					
County:	Bexar	Comal	Kinney	Medina	Uvalde
Original (1 req.)	—	—	—	—	—
Region (1 req.)	—	—	—	—	—
County(ies)	—	—	—	—	—
Groundwater Conservation District(s)	<input type="checkbox"/> Edwards Aquifer Authority <input type="checkbox"/> Trinity-Glen Rose	<input type="checkbox"/> Edwards Aquifer Authority	<input type="checkbox"/> Kinney	<input type="checkbox"/> EAA <input type="checkbox"/> Medina	<input type="checkbox"/> EAA <input type="checkbox"/> Uvalde
City(ies) Jurisdiction	<input type="checkbox"/> Castle Hills <input type="checkbox"/> Fair Oaks Ranch <input type="checkbox"/> Helotes <input type="checkbox"/> Hill Country Village <input type="checkbox"/> Hollywood Park <input type="checkbox"/> San Antonio (SAWS) <input type="checkbox"/> Shavano Park	<input type="checkbox"/> Bulverde <input type="checkbox"/> Fair Oaks Ranch <input type="checkbox"/> Garden Ridge <input type="checkbox"/> New Braunfels <input type="checkbox"/> Schertz	NA	<input type="checkbox"/> San Antonio ETJ (SAWS)	NA

I certify that to the best of my knowledge, that the application is complete and accurate. This application is hereby submitted to TCEQ for administrative review and technical review.	
Nick Sandlin, P.E. (Sandlin Services, LLC)	
Print Name of Customer/Authorized Agent	3/20/2024
Signature of Customer/Authorized Agent	Date

FOR TCEQ INTERNAL USE ONLY			
Date(s) Reviewed:		Date Administratively Complete:	
Received From:		Correct Number of Copies:	
Received By:		Distribution Date:	
EAPP File Number:		Complex:	
Admin. Review(s) (No.):		No. AR Rounds:	
Delinquent Fees (Y/N):		Review Time Spent:	
Lat./Long. Verified:		SOS Customer Verification:	
Agent Authorization Complete/Notarized (Y/N):		Fee Check:	Payable to TCEQ (Y/N):
Core Data Form Complete (Y/N):			Signed (Y/N):
Core Data Form Incomplete Nos.:			Less than 90 days old (Y/N):

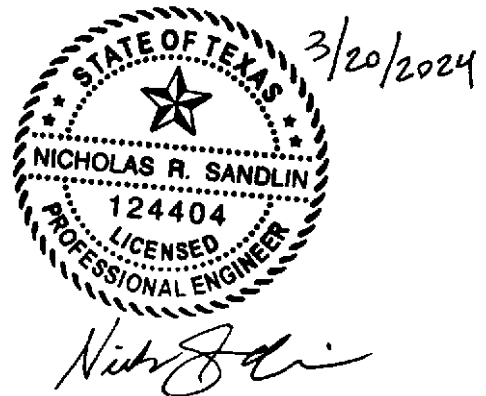



PEC Liberty Hill
CONTRIBUTING ZONE PLAN MODIFICATION

Modification of a Previously Approved Contributing Zone Plan (TCEQ-10259)

Modification of a Previously Approved Contributing Zone Plan

Texas Commission on Environmental Quality

for Regulated Activities on the Edwards Aquifer Recharge Zone and Transition Zone and Relating to 30 TAC 213.4(j), Effective June 1, 1999

To ensure that the application is administratively complete, confirm that all fields in the form are complete, verify that all requested information is provided, consistently reference the same site and contact person in all forms in the application, and ensure forms are signed by the appropriate party.

Note: Including all the information requested in the form and attachments contributes to more streamlined technical reviews.

Signature

To the best of my knowledge, the responses to this form accurately reflect all information requested concerning the proposed regulated activities and methods to protect the Edwards Aquifer. This **Modification of a Previously Approved Contributing Zone Plan** is hereby submitted for TCEQ review and executive director approval. The request was prepared by:

Print Name of Customer/Agent: Nick Sandlin, P.E. (Sandlin Services, LLC)

Date: 3/20/2024

Signature of Customer/Agent:

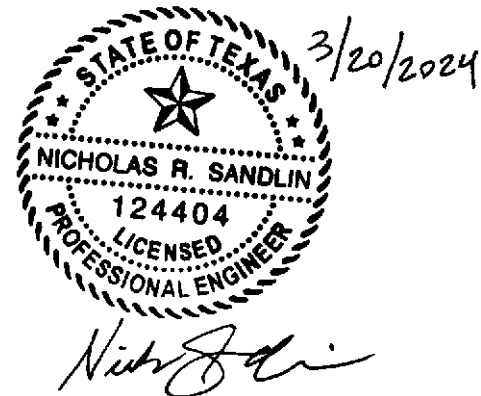

Project Information

1. Current Regulated Entity Name: PEC Liberty Hill
Original Regulated Entity Name: Seward Junction Office And Warehouse
Assigned Regulated Entity Number(s) (RN): 105473979
Edwards Aquifer Protection Program ID Number(s): 11-08030503 and 11001078
 The applicant has not changed and the Customer Number (CN) is: 601327927
 The applicant or Regulated Entity has changed. A new Core Data Form has been provided.
2. **Attachment A: Original Approval Letter and Approved Modification Letters.** A copy of the original approval letter and copies of any modification approval letters are attached.
3. A modification of a previously approved plan is requested for (check all that apply):

- Any physical or operational modification of any best management practices or structure(s), including but not limited to temporary or permanent ponds, dams, berms, silt fences, and diversionary structures;
- Any change in the nature or character of the regulated activity from that which was originally approved;
- A change that would significantly impact the ability to prevent pollution of the Edwards Aquifer and hydrologically connected surface water; or
- Any development of land previously identified in a contributing zone plan as undeveloped.

4. Summary of Proposed Modifications (select plan type being modified). If the approved plan has been modified more than once, copy the appropriate table below, as necessary, and complete the information for each additional modification.

<i>CZP Modification</i>	<i>Approved Project</i>	<i>Proposed Modification</i>
<i>Summary</i>		
Acres	<u>8.22 AC Total (2 Lots - 6.22</u>	<u>N/A</u>
Type of Development	<u>AC & 2 AC)</u>	<u>N/A</u>
Number of Residential	<u>Industrial</u>	<u>N/A</u>
Lots	<u>0</u>	
Impervious Cover (acres)		<u>N/A</u>
Impervious Cover (%)	<u>5.61</u>	<u>N/A</u>
Permanent BMPs	<u>68.2</u>	<u>N/A</u>
Other	<u>Sand Filter System</u>	<u>_____</u>
	<u>_____</u>	

<i>AST Modification</i>	<i>Approved Project</i>	<i>Proposed Modification</i>
<i>Summary</i>		
Number of ASTs	<u>0</u>	<u>1- 10,000 gal split tank</u>
Other	<u>_____</u>	<u>_____</u>

<i>UST Modification</i>	<i>Approved Project</i>	<i>Proposed Modification</i>
<i>Summary</i>		
Number of USTs	<u>_____</u>	<u>_____</u>
Other	<u>_____</u>	<u>_____</u>

5. **Attachment B: Narrative of Proposed Modification.** A detailed narrative description of the nature of the proposed modification is attached. It discusses what was approved, including previous modifications, and how this proposed modification will change the approved plan.
6. **Attachment C: Current Site Plan of the Approved Project.** A current site plan showing the existing site development (i.e., current site layout) at the time this application for modification is attached. A site plan detailing the changes proposed in the submitted modification is required elsewhere.
- The approved construction has not commenced. The original approval letter and any subsequent modification approval letters are included as Attachment A to document that the approval has not expired.
- The approved construction has commenced and has been completed. Attachment C illustrates that the site was constructed as approved.
- The approved construction has commenced and has been completed. Attachment C illustrates that the site was **not** constructed as approved.
- The approved construction has commenced and has **not** been completed. Attachment C illustrates that, thus far, the site was constructed as approved.
- The approved construction has commenced and has **not** been completed. Attachment C illustrates that, thus far, the site was **not** constructed as approved.
7. Acreage has not been added to or removed from the approved plan.
- Acreage has been added to or removed from the approved plan and is discussed in *Attachment B: Narrative of Proposed Modification*.
8. Submit one (1) original and one (1) copy of the application, plus additional copies as needed for each affected incorporated city, groundwater conservation district, and county in which the project will be located. The TCEQ will distribute the additional copies to these jurisdictions. The copies must be submitted to the appropriate regional office.



**Modification of a Previously Approved Contributing Zone Plan
(TCEQ-10259)**

**Attachment A:
Original Approval Letter and Approved Modification Letters**

Buddy Garcia, *Chairman*
Larry R. Soward, *Commissioner*
Bryan W. Shaw, Ph.D., *Commissioner*
Glenn Shankle, *Executive Director*



COPY

TEXAS COMMISSION ON ENVIRONMENTAL QUALITY

Protecting Texas by Reducing and Preventing Pollution

April 16, 2008

Mr. Wayne McKee
Pedernales Electric Cooperative, Inc.
P.O. Box 1
Johnson City, TX 78636

Re: Edwards Aquifer, (Williamson County)
NAME OF PROJECT: Seward Junction Office and Warehouse
PROJECT LOCATION: 10325 West Highway 29, Liberty Hill
Request for Approval of a Contributing Zone Plan - CZP
30 Texas Administrative Code (TAC) Chapter 213 Edwards Aquifer
Edwards Aquifer Protection Program ID No.: 08030503

Dear Mr. McKee:

The Texas Commission on Environmental Quality (TCEQ) has completed its review of the CZP application for the referenced project submitted to the Austin Regional Office by Baker-Aicklen and Associates, Inc., on behalf of Pedernales Electric on March 5, 2008. Final review was completed after additional information was received on April 11, 2008. As presented to the TCEQ, the Temporary and Permanent Best Management Practices (BMPs) and construction plans were prepared by a Texas Licensed Professional Engineer and appear to be in general compliance with the requirements of 30 TAC Chapter 213. These planning materials were sealed, signed, and dated by a Texas Licensed Professional Engineer. Therefore, based on the engineer's concurrence of compliance, the planning materials for construction of the proposed project and pollution abatement measures are hereby approved subject to applicable state rules and the conditions in this letter. The applicant or a person affected may file with the chief clerk a motion for reconsideration of the executive director's final action on this Contributing Zone Plan. A motion for reconsideration must be filed no later than 23 days after the date of this approval letter. This approval expires two (2) years from the date of this letter unless, prior to the expiration date, more than 10% of the construction has commenced on the project or an extension of time has been requested.

PROJECT DESCRIPTION

The total site consists of 8.22 acres of undisturbed property located in the South San Gabriel stream basin. A 6.22 acre lot and a 2 acre lot will be combined to yield the total site. The project will include a customer service office, training facility, warehouse, maintenance yard, a water quality and detention pond, associated appurtenances. There will be a total of 5.61 acres of impervious cover (68.2%).

REPLY TO: REGION 11 • 2800 S. INTERSTATE HWY. 35, STE. 100 • AUSTIN, TEXAS 78704-5700 • 512-339-2929 • FAX 512-339-3795

P.O. Box 13087 • Austin, Texas 78711-3087 • 512-239-1000 • Internet address: www.tceq.state.tx.us

printed on recycled paper using soy-based ink

Temporary best management practices (BMPs) consisting of silt fences, rock berms and stabilized construction entrances will be implemented to treat and control stormwater runoff during construction activities. Project wastewater will be disposed of by an on site septic system.

PERMANENT POLLUTION ABATEMENT MEASURES

Stormwater will be treated by a proposed sedimentation/filtration pond. The pond is designed to accept runoff from the site as well as 1.25 acres of upgradient stormwater. The water quality pond has a total volume of 34,048 cubic feet. The filtration basin has a volume of 6,656 cubic feet and the sedimentation basin has a volume of 27,393 cubic feet. The area of the filtration basin is 3,328 square feet. According to the CZP, the approved measures meet the required 80 percent removal of the increased load in total suspended solids caused by the project.

SPECIAL CONDITIONS

- I. Intentional discharges of sediment laden stormwater during construction are not allowed. If dewatering excavated areas and/or areas of accumulated stormwater becomes necessary, the discharge shall be filtered through appropriately selected temporary best management practices. These may include vegetative filter strips, sediment traps, rock berms, silt fence rings, etc.
- II. This approval does not authorize the installation of temporary aboveground storage tanks on this project. If the contractor desires to install a temporary aboveground storage tank for use during construction, an application to modify this approval must be submitted and approved prior to installation. The application must include information related to tank location and spill containment. Refer to Standard Condition No. 3 below.
- III. The holder of the approved Edwards Aquifer CZP must comply with all provisions of 30 TAC chapter 213 and all best management practices and measures contained in the application.

STANDARD CONDITIONS

1. Pursuant to Chapter 7 Subchapter C of the Texas Water Code, any violations of the requirements in 30 TAC Chapter 213 may result in administrative penalties.

Prior to Commencement of Construction:

2. All contractors conducting regulated activities at the referenced project location shall be provided a copy of this notice of approval. At least one complete copy of the approved Contributing Zone Plan and this notice of approval shall be maintained at the project until all regulated activities are completed.
3. Any modification to the activities described in the referenced CZP application following the date of approval may require the submittal of a plan to modify this approval, including the payment of appropriate fees and all information necessary for its review and approval prior to initiating construction of the modifications.

4. The applicant must provide written notification of intent to commence construction of the referenced project. Notification must be submitted to the Austin Regional Office no later than 48 hours prior to commencement of the regulated activity. Written notification must include the name of the approved plan and ID number for the regulated activity, the date on which the regulated activity will commence, and the name of the prime contractor with the name and telephone number of the contact person.
5. Temporary erosion and sedimentation (E&S) controls, i.e., silt fences, rock berms, stabilized construction entrances, or other controls described in the approved Storm Water Pollution Prevention Plan (SWPPP) must be installed prior to construction and maintained during construction. Temporary E&S controls may be removed when vegetation is established and the construction area is stabilized. The water quality pond shall be used as a sedimentation basin during construction. The TCEQ may monitor stormwater discharges from the site to evaluate the adequacy of temporary E&S control measures. Additional controls may be necessary if excessive solids are being discharged from the site.

During Construction:

6. During the course of regulated activities related to this project, the applicant or his agent shall comply with all applicable provisions of 30 TAC Chapter 213, Edwards Aquifer. The applicant shall remain responsible for the provisions and conditions of this approval until such responsibility is legally transferred to another person or entity.
7. If sediment escapes the construction site, the sediment must be removed at a frequency sufficient to minimize offsite impacts to water quality (e.g., fugitive sediment in street being washed into surface streams or sensitive features by the next rain). Sediment must be removed from sediment traps or sedimentation ponds not later than when design capacity has been significantly reduced. Litter, construction debris, and construction chemicals exposed to stormwater shall be prevented from becoming a pollutant source for stormwater discharges (e.g., screening outfalls, picked up daily).
8. The following records shall be maintained and made available to the executive director upon request: the dates when major grading activities occur, the dates when construction activities temporarily or permanently cease on a portion of the site, and the dates when stabilization measures are initiated.
9. Stabilization measures shall be initiated as soon as practicable in portions of the site where construction activities have temporarily or permanently ceased, and construction activities will not resume within 21 days. When the initiation of stabilization measures by the 14th day is precluded by weather conditions, stabilization measures shall be initiated as soon as practicable.

After Completion of Construction:

10. Upon legal transfer of this property, the new owner(s) is required to comply with all terms of the approved Contributing Zone Plan. If the new owner intends to commence any new regulated activity on the site, a new Contributing Zone Plan that specifically addresses the new activity must be submitted to the executive director. Approval of the

April 16, 2008

plan for the new regulated activity by the executive director is required prior to commencement of the new regulated activity.

11. Owners of permanent BMPs and measures must insure that the BMPs and measures are constructed and function as designed. A Texas Licensed Professional Engineer must certify in writing that the permanent BMPs or measures were constructed as designed. The certification letter must be submitted to the Austin Regional Office within 30 days of site completion.
12. The applicant shall be responsible for maintaining the permanent BMPs after construction until such time as the maintenance obligation is either assumed in writing by another entity having ownership or control of the property (such as without limitation, an owner's association, a new property owner or lessee, a district, or municipality) or the ownership of the property is transferred to the entity. The regulated entity shall then be responsible for maintenance until another entity assumes such obligations in writing or ownership is transferred. A copy of the transfer of responsibility must be filed with the executive director through the Austin Regional Office within 30 days of the transfer. A copy of the transfer form (TCEQ-10263) is enclosed.
13. A Contributing Zone Plan approval or extension will expire and no extension will be granted if more than 50% of the total construction has not been completed within ten years from the initial approval of a plan. A new Contributing Zone Plan must be submitted to the Austin Regional Office with the appropriate fees for review and approval by the executive director prior to commencing any additional regulated activities.
14. At project locations where construction is initiated and abandoned, or not completed, the site shall be returned to a condition such that the aquifer is protected from potential contamination.

If you have any questions or require additional information, please contact Mr. Russ Alexander, P.G., of the Edwards Aquifer Protection Program of the Austin Regional Office at (512) 339-2929.

Sincerely,

Glenn Shankle
Executive Director

GS/raa

enclosure

cc: Mr. David Olson, Baker-Aicklen and Associates, Inc. Austin
Mr. Paulo C. Pinto, B.S., R.S., Director of Environmental Services, Williamson County Health District
Ms. Kathy Clark, City Secretary, City of Liberty Hill
Mr. Sam Roberts, P.E., Director of Public Works, City of Cedar Park
TCEQ Central Records



Modification of a Previously Approved Contributing Zone Plan (TCEQ-10259)

Attachment B: Narrative of Proposed Modification

The proposed 0.15 AC development is the addition of an Excell Aboveground Storage Tank (AST) fuel island on the existing caliche-based parking/storage area. The fueling system will be backed up by one backup generator (150-gallon diesel). The proposed fuel island will include the following:

1. One (1) 10,000 Gallon double-walled AST – split 7,000 gal Diesel/3,000 gal Gas UL 2085 Fireguard tank with rod ladder and e-vents
2. Two (2) 20-Gallon remote spill basins with 3” fill piping, 3” ball valves and 3” quick fill connections
3. Two (2) 2” X 3” overflow devices set at 90%
4. Two (2) DEF blue boxes with pulse output with external filters and 5-minute timers
5. Three (3) Centeron Cell Monitors with 500 call block
6. Franklin DEF nozzle and hose
7. One (1) Fuelmaster 6-hose FMS with network capable
8. One (1) 500-Gallon DEF Poly Tank

The proposed construction will not change the existing Impervious Cover (IC). Therefore, the CZP Modification request does not require additional Permanent BMPs. The existing and modified CZPs (EAPP 11-08030503 dated April 16, 2008 and EAPP 11001078 dated May 23, 2018) included a Sand Filter Basin Permanent BMP for stormwater water quality control. The proposed modification does not increase the Impervious Cover (IC) at the site. The existing sand filter basin BMP will continue to meet requirements to treat stormwater runoff at the site.



**Modification of a Previously Approved Contributing Zone Plan
(TCEQ-10259)**

**Attachment C:
Current Site Plan of the Approved Project**

ZONING NOTE

THIS DEVELOPMENT MUST MEET ALL C-3 ZONING REQUIREMENTS

GENERAL SITE PLAN NOTES

1. THIS DEVELOPMENT SHALL COMPLY WITH THE UNIFIED DEVELOPMENT CODE OF THE CITY OF LIBERTY HILL.
2. THE CITY OF ROUND ROCK DESIGN AND CONSTRUCTION STANDARDS SHALL APPLY TO THIS DEVELOPMENT UNLESS OTHERWISE SPECIFIED BY THE UDC.
3. ALL SIGNAGE REQUIRES SEPARATE APPROVAL FROM THE CITY OF LIBERTY HILL. NO SIGNAGE IS APPROVED WITH THIS SITE PLAN.
4. DRIVEWAY PERMITS WILL REQUIRE APPROVAL BY THE TEXAS DEPARTMENT OF TRANSPORTATION AND/OR WILLIAMSON COUNTY ROAD AND BRIDGE.
5. A TRAFFIC IMPACT ANALYSIS IS NOT REQUIRED FOR THIS PROJECT.
6. NO PORTION OF THIS SITE IS LOCATED IN A FEMA 100 YEAR FLOODPLAIN AS PER F.E.M.A. PANEL NO. 48491C0100C, WILLIAMSON COUNTY, DATED SEPTEMBER 27, 1991 AND PANEL NO. 48491C0225D, WILLIAMSON COUNTY, DATED NOVEMBER 2, 1995.
7. ALL DIMENSIONS ARE TO THE BACK OF CURBS, UNLESS OTHERWISE NOTED. ALL RADIUS DATA IS TO THE FACE OF CURB.
8. APPROVAL OF THIS SITE PLAN DOES NOT INCLUDE BUILDING PERMIT APPROVAL.
9. PEDESTRIAN ACCESSIBILITY (APPROACH, ENTRY, EXIT) TO ALL NEWLY CONSTRUCTED BUILDINGS WILL BE IN ACCORDANCE WITH THE DESIGN AND CONSTRUCTION REQUIREMENTS OF THE TRANSPORTATION MANUAL, ADA AND TMS.



TEXAS ONE CALL SYSTEM
 1-800-245-4545
 UNDER PENALTY OF LAW, THE CONTRACTOR IS REQUIRED TO CONTACT THE TEXAS ONE CALL SYSTEM AT LEAST 48 HOURS BEFORE STARTING EXCAVATION. PROJECTS IN THE CITY OF AUSTIN JURISDICTION USE AUSTIN ONE CALL @ 1-800-344-8377

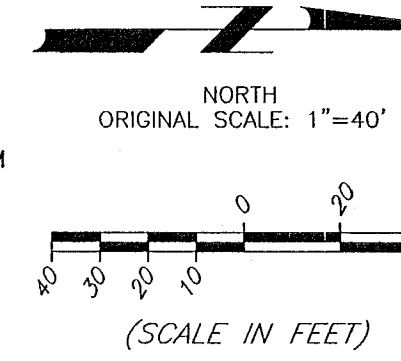

CHING RUTH HSU CHANG
 11.98 ACRES
 DOC. NO. 9725003

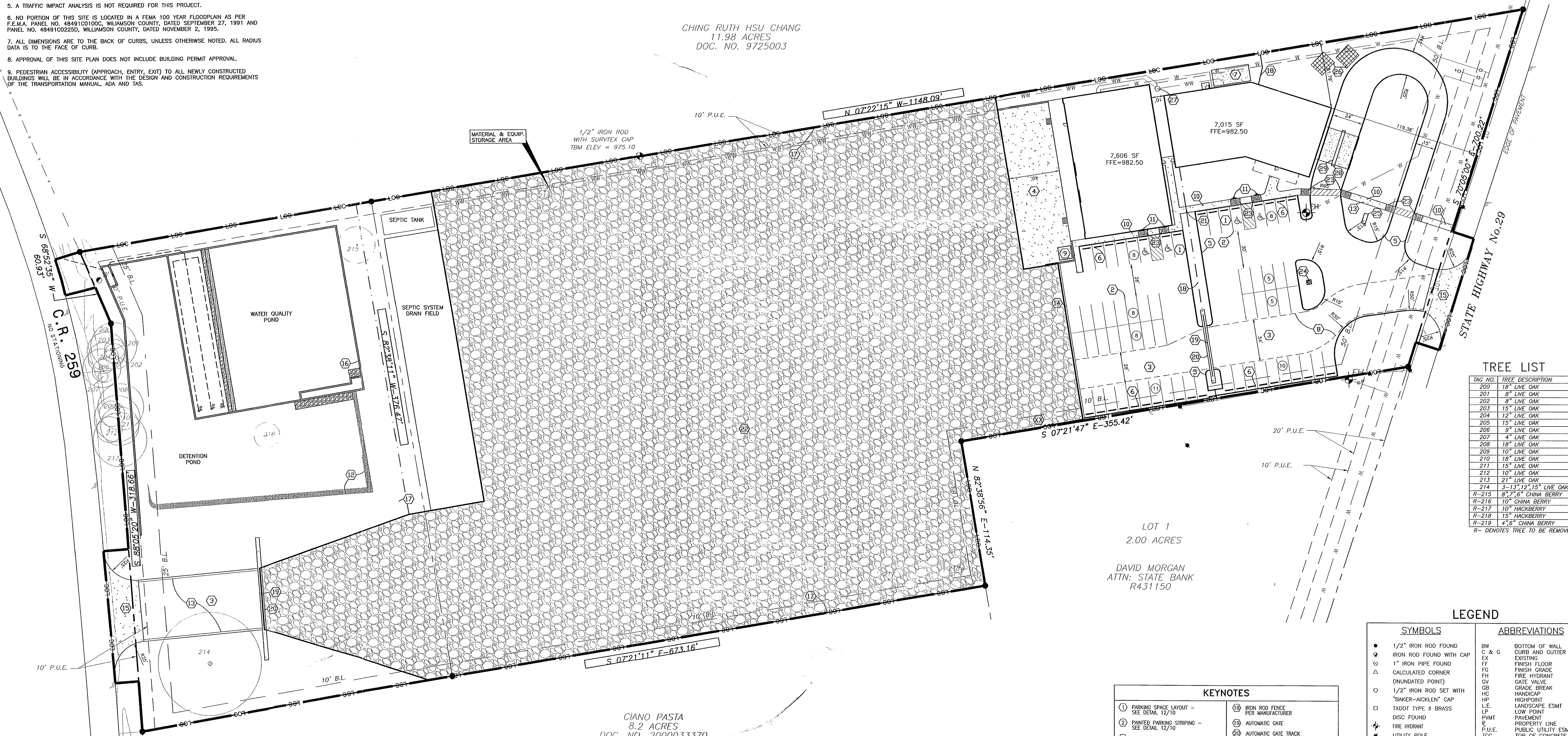

TREE LIST

TAG NO.	TREE DESCRIPTION
200	18" LIVE OAK
201	8" LIVE OAK
202	8" LIVE OAK
203	15" LIVE OAK
204	12" LIVE OAK
205	15" LIVE OAK
206	9" LIVE OAK
207	4" LIVE OAK
208	18" LIVE OAK
209	10" LIVE OAK
210	18" LIVE OAK
211	15" LIVE OAK
212	10" LIVE OAK
213	21" LIVE OAK
214	3"-13"-15" LIVE OAK
R-215	6", 7", 8" CHINA BERRY
R-216	10" CHINA BERRY
R-217	10" HACKBERRY
R-218	15" HACKBERRY
R-219	4", 5" CHINA BERRY

R - DENOTES TREE TO BE REMOVED

LEGEND

SYMBOLS

- 1/2" IRON ROD FOUND
- IRON ROD FOUND WITH CAP
- 1" IRON PIPE FOUND
- △ CALCULATED CORNER (UNDATED POINT)
- 1/2" IRON ROD SET WITH "BAKER-AICKLEN" CAP
- TUDOT TYPE II BRASS
- DISC FOUND
- FIRE HYDRANT
- UTILITY POLE
- LIGHT POLE
- TELEPHONE BOX
- ELECTRIC BOX
- JUNCTION BOX
- ELECTRIC METER
- WATER METER
- WATER VALVE
- MARKER SIGN FOC
- AUTO AIR RELEASE VALVE
- GUY WIRE
- WASTEWATER MANHOLE
- STORMSEWER MANHOLE
- SIGN
- BENCHMARK LOCATION
- EDGE OF ASPHALT
- KEYHOLES
- PARKING COUNT
- TREE TO BE SAVED
- TREE TO BE REMOVED

ABBREVIATIONS

- BW C & G BOTTOM OF WALL CURB AND GUTTER
- EX EXISTING
- FF FINISH FLOOR
- FG FINISH GRADE
- FH FIRE HYDRANT
- GV GATE VALVE
- GB GRADE BREAK
- HC HANDICAP
- HP HIGHPOINT
- L.E. LANDSCAPE ESMT
- LP LOW POINT
- PMAT PAVEMENT
- PL PROPERTY LINE
- P.U. PUBLIC UTILITY ESMT
- TC TOP OF CONCRETE
- TC TOP OF CURB
- TG TOP OF GRATE
- TC CENTERLINE
- TP TOP OF PAVEMENT
- FL FLOWLINE
- TW TOP OF WALL
- WL WATER LINE
- WV WATER VALVE

LINETYPES

- PROPERTY BOUNDARY
- LIMITS OF CONSTRUCTION
- FENCES (CHAINLINK)
- (IRON)
- (WOOD)
- (8-WIRE)
- DITCH (CREEK) LINE
- EXISTING CONTOURS
- PROPOSED CONTOURS
- CURB & GUTTER
- GRATE INLET
- CURB INLET
- UNDERGROUND ELEC.
- OVERHEAD UTILITY
- UNDERGROUND TELE./
- OVERHEAD TELEPHONE
- UNDERGROUND GAS LINE
- WATER LINE
- WASTEWATER LINE

KEYNOTES

- 1) PARKING SPACE LAYOUT - SEE DETAIL 12/10
- 2) PAINTED PARKING STRIPING - SEE DETAIL 12/10
- 3) ASPHALT PAVEMENT - SEE DETAIL 7/11
- 4) CONCRETE PAVEMENT - SEE DETAIL 6/11
- 5) STANDARD CURB AND GUTTER - SEE DETAIL 1/13
- 6) RUBBER WHEEL STOP - SEE DETAIL 3/12
- 7) TRANSFORMER AND GENERATOR ON CONCRETE PAD
- 8) FIRE LANE STRIPING PER FIRE DEPARTMENT REQUIREMENTS
- 9) DUMPSTER
- 10) 5' SIDEWALK - SEE DETAIL 2/13
- 11) HANDICAPPED SIGN - SEE DETAIL 4/12
- 12) MORTARED ROCK WALL - SEE DETAIL 2/12
- 13) ACCESSIBLE ROUTE
- 14) 18" REBORN CURB - SEE DETAIL 3/13
- 15) TYPE II COMMERCIAL DRIVEWAY - SEE DETAIL 1/12
- 16) POND WALL - SEE DETAIL X/16
- 17) 8" CONCRETE FENCE PER MANUFACTURER
- 18) IRON ROD FENCE PER MANUFACTURER
- 19) AUTOMATIC GATE
- 20) AUTOMATIC GATE TRACK
- 21) KEYCARD GATE
- 22) LIMESTONE BASE - PER OWNER APPROVAL
- 23) SIDEWALK RAMP - SEE DETAIL 8/12
- 24) FLAG POLE
- 25) SIGN - SEE LANDSCAPE PLAN
- 26) SOLAR PANELS
- 27) GRINDER PUMP - SEE SHEET 17
- 28) BOLLARD
- 29) CONCRETE ISLAND

SITE AREA TABLE

LEGAL: LOT 1A, BLOCK A

GROSS SITE AREA = 8.22 ACRES
 CONSTRUCTION SITE AREA = 8.33 ACRES
 IMPERVIOUS COVER AREA = 5.81 ACRES
 % IMPERVIOUS COVER = 68.25%

PARKING TABULATIONS

VEHICLE SPACES	REQUIRED	PROVIDED
TOTAL	-	63
HANDICAP SPACES (INCLUDED IN VEHICLE SPACES)	-	4
LOADING	-	-

CIANO PASTA
 8.2 ACRES
 DOC. NO. 2000033370

LOT 1
 2.00 ACRES
 DAVID MORGAN
 ATTN: STATE BANK
 R431150

204 S. IH36, STE. 104
 GEORGETOWN, TX 78626
 (512) 763-1100

BAKER-AICKLEN & ASSOCIATES, INC.
 Engineers • Surveyors • GIS • Planning

DESIGNED: D.M. PLOT SCALE: 1" = 1' LAYOUT: SITE
 DRAWN: D.M. DATE: 2-22-08
 REVIEWED: C.M. DWG. NAME: 1700-5-02 SITE.dwg

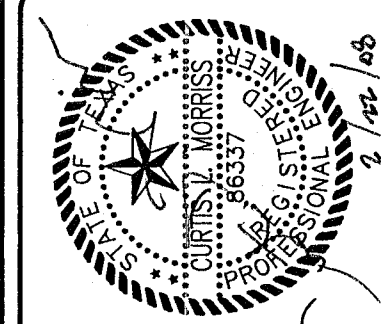

NO.	DATE	REVISIONS	RECOM'D

CLIENT: PEDERNALES ELECTRIC COOPERATIVE, INC.

PROJECT: SEWARD JUNCTION OFFICE & WAREHOUSE

SITE PLAN

SHEET TITLE

PROJECT No.
 1700-5-002

SHEET No.
C-6
 6 OF 23

XREFS: 1700-5-002 SDR, 1700-5-002 EBS, 1700-5-002 LG, 1700-5-002 PBS, 1700-5-002 KN, SEAL-CUM



PEC Liberty Hill
CONTRIBUTING ZONE PLAN MODIFICATION

Contributing Zone Plan Application (TCEQ-10257)

Contributing Zone Plan Application

Texas Commission on Environmental Quality

for Regulated Activities on the Contributing Zone to the Edwards Aquifer and Relating to 30 TAC §213.24(1), Effective June 1, 1999

To ensure that the application is administratively complete, confirm that all fields in the form are complete, verify that all requested information is provided, consistently reference the same site and contact person in all forms in the application, and ensure forms are signed by the appropriate party.

Note: Including all the information requested in the form and attachments contributes to more streamlined technical reviews.

Signature

To the best of my knowledge, the responses to this form accurately reflect all information requested concerning the proposed regulated activities and methods to protect the Edwards Aquifer. This **Contributing Zone Plan Application** is hereby submitted for TCEQ review and Executive Director approval. The application was prepared by:

Print Name of Customer/Agent: Nick Sandlin, P.E. (Sandlin Services, LLC)

Date: 3/20/2024

Signature of Customer/Agent:



Regulated Entity Name: PEC Liberty Hill

Project Information

1. County: Williamson
2. Stream Basin: South Fork San Gabriel River
3. Groundwater Conservation District (if applicable): N/A
4. Customer (Applicant):

Contact Person: Bud Collora

Entity: Pedernales Electric Cooperative, Inc.

Mailing Address: P.O. Box 1

City, State: Johnson City, Texas

Telephone: 830-868-6056

Email Address: bud.collora@peci.com

Zip: 78636

Fax: _____

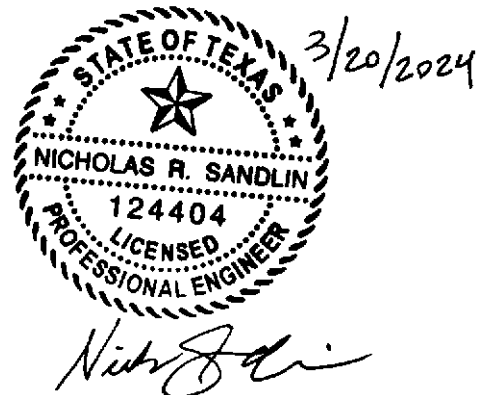

5. Agent/Representative (If any):

Contact Person: Nick Sandlin, P.E.

Entity: Sandlin Services, LLC

Mailing Address: 9111 Jollyville Rd. Suite 212

City, State: Austin, Texas

Zip: 78759

Telephone: 806-679-7303

Fax: _____

Email Address: nick@sandlinservices.com

6. Project Location:

- The project site is located inside the city limits of Liberty Hill, TX.
- The project site is located outside the city limits but inside the ETJ (extra-territorial jurisdiction) of _____.
- The project site is not located within any city's limits or ETJ.

7. The location of the project site is described below. Sufficient detail and clarity has been provided so that the TCEQ's Regional staff can easily locate the project and site boundaries for a field investigation.

10625 W SH 29, Liberty Hill, TX 78642

8. **Attachment A - Road Map.** A road map showing directions to and the location of the project site is attached. The map clearly shows the boundary of the project site.

9. **Attachment B - USGS Quadrangle Map.** A copy of the official 7 ½ minute USGS Quadrangle Map (Scale: 1" = 2000") is attached. The map(s) clearly show:

- Project site boundaries.
- USGS Quadrangle Name(s).

10. **Attachment C - Project Narrative.** A detailed narrative description of the proposed project is attached. The project description is consistent throughout the application and contains, at a minimum, the following details:

- Area of the site
- Offsite areas
- Impervious cover
- Permanent BMP(s)
- Proposed site use
- Site history
- Previous development
- Area(s) to be demolished

11. Existing project site conditions are noted below:

- Existing commercial site
- Existing industrial site
- Existing residential site

- Existing paved and/or unpaved roads
- Undeveloped (Cleared)
- Undeveloped (Undisturbed/Not cleared)
- Other: _____

12. The type of project is:

- Residential: # of Lots: _____
- Residential: # of Living Unit Equivalents: _____
- Commercial
- Industrial
- Other: _____

13. Total project area (size of site): (Lots 2 and 3) 8.22 Acres

Total disturbed area: 0.15 Acres

14. Estimated projected population: N/A

15. The amount and type of impervious cover expected after construction is complete is shown below:

Table 1 - Impervious Cover

<i>Impervious Cover of Proposed Project</i>	<i>Sq. Ft.</i>	<i>Sq. Ft./Acre</i>	<i>Acres</i>
Structures/Rooftops	14,621	÷ 43,560 =	.34
Parking	34,897	÷ 43,560 =	.80
Other paved surfaces	194,854	÷ 43,560 =	4.47
Total Impervious Cover	244,372	÷ 43,560 =	5.61

Total Impervious Cover 5.61 ÷ Total Acreage 8.22 X 100 = 68.2% Impervious Cover

16. **Attachment D - Factors Affecting Surface Water Quality.** A detailed description of all factors that could affect surface water quality is attached. If applicable, this includes the location and description of any discharge associated with industrial activity other than construction.

17. Only inert materials as defined by 30 TAC 330.2 will be used as fill material.

For Road Projects Only

Complete questions 18 - 23 if this application is exclusively for a road project.

N/A

18. Type of project:

- TXDOT road project.
- County road or roads built to county specifications.
- City thoroughfare or roads to be dedicated to a municipality.
- Street or road providing access to private driveways.

19. Type of pavement or road surface to be used:

- Concrete
- Asphaltic concrete pavement
- Other: _____

20. Right of Way (R.O.W.):

Length of R.O.W.: _____ feet.

Width of R.O.W.: _____ feet.

$L \times W = \text{_____ Ft}^2 \div 43,560 \text{ Ft}^2/\text{Acre} = \text{_____ acres.}$

21. Pavement Area:

Length of pavement area: _____ feet.

Width of pavement area: _____ feet.

$L \times W = \text{_____ Ft}^2 \div 43,560 \text{ Ft}^2/\text{Acre} = \text{_____ acres.}$

Pavement area _____ acres \div R.O.W. area _____ acres $\times 100 = \text{_____ \%}$ impervious cover.

22. A rest stop will be included in this project.

A rest stop will not be included in this project.

23. Maintenance and repair of existing roadways that do not require approval from the TCEQ Executive Director. Modifications to existing roadways such as widening roads/adding shoulders totaling more than one-half (1/2) the width of one (1) existing lane require prior approval from the TCEQ.

Stormwater to be generated by the Proposed Project

24. **Attachment E - Volume and Character of Stormwater.** A detailed description of the volume (quantity) and character (quality) of the stormwater runoff which is expected to occur from the proposed project is attached. The estimates of stormwater runoff quality and quantity are based on area and type of impervious cover. Include the runoff coefficient of the site for both pre-construction and post-construction conditions.

Wastewater to be generated by the Proposed Project

25. Wastewater is to be discharged in the contributing zone. Requirements under 30 TAC §213.6(c) relating to Wastewater Treatment and Disposal Systems have been satisfied.

N/A

26. Wastewater will be disposed of by:

On-Site Sewage Facility (OSSF/Septic Tank):

Attachment F - Suitability Letter from Authorized Agent. An on-site sewage facility will be used to treat and dispose of the wastewater from this site. The appropriate licensing authority's (authorized agent) written approval is attached. It states that the land is suitable for the use of private sewage facilities and will meet or exceed the requirements for on-site sewage facilities as specified under 30 TAC Chapter 285 relating to On-site Sewage Facilities.

Each lot in this project/development is at least one (1) acre (43,560 square feet) in size. The system will be designed by a licensed professional engineer or registered sanitarian and installed by a licensed installer in compliance with 30 TAC Chapter 285.

Sewage Collection System (Sewer Lines):

The sewage collection system will convey the wastewater to the _____ (name) Treatment Plant. The treatment facility is:

Existing.

Proposed.

N/A

Permanent Aboveground Storage Tanks(ASTs) ≥ 500 Gallons

Complete questions 27 - 33 if this project includes the installation of AST(s) with volume(s) greater than or equal to 500 gallons.

N/A

27. Tanks and substance stored:

Table 2 - Tanks and Substance Storage

<i>AST Number</i>	<i>Size (Gallons)</i>	<i>Substance to be Stored</i>	<i>Tank Material</i>
1	10,000	Diesel/Gas	A36 MILD CARBON STEEL (UL 2085, DOUBLE WALLED)
2			
3			
4			
5			

N/A - TANK IS DOUBLE WALLED

Total x 1.5 = 15,000 Gallons

28. The AST will be placed within a containment structure that is sized to capture one and one-half (1 1/2) times the storage capacity of the system. For facilities with more than one tank system, the containment structure is sized to capture one and one-half (1 1/2) times the cumulative storage capacity of all systems.

Attachment G - Alternative Secondary Containment Methods. Alternative methods for providing secondary containment are proposed. Specifications showing equivalent protection for the Edwards Aquifer are attached.

29. Inside dimensions and capacity of containment structure(s):

Table 3 - Secondary Containment

<i>Length (L)(Ft.)</i>	<i>Width(W)(Ft.)</i>	<i>Height (H)(Ft.)</i>	<i>L x W x H = (Ft3)</i>	<i>Gallons</i>

Total: _____ Gallons

30. Piping:

- All piping, hoses, and dispensers will be located inside the containment structure.
- Some of the piping to dispensers or equipment will extend outside the containment structure.
- The piping will be aboveground
- The piping will be underground

31. The containment area must be constructed of and in a material impervious to the substance(s) being stored. The proposed containment structure will be constructed of: _____.

32. **Attachment H - AST Containment Structure Drawings.** A scaled drawing of the containment structure is attached that shows the following:

- Interior dimensions (length, width, depth and wall and floor thickness).
- Internal drainage to a point convenient for the collection of any spillage.
- Tanks clearly labeled
- Piping clearly labeled
- Dispenser clearly labeled

33. Any spills must be directed to a point convenient for collection and recovery. Spills from storage tank facilities must be removed from the controlled drainage area for disposal within 24 hours of the spill.

- In the event of a spill, any spillage will be removed from the containment structure within 24 hours of the spill and disposed of properly.
- In the event of a spill, any spillage will be drained from the containment structure through a drain and valve within 24 hours of the spill and disposed of properly. The drain and valve system are shown in detail on the scaled drawing.

Site Plan Requirements

Items 34 - 46 must be included on the Site Plan.

34. The Site Plan must have a minimum scale of 1" = 400'.
Site Plan Scale: 1" = 30'.
35. 100-year floodplain boundaries:
- Some part(s) of the project site is located within the 100-year floodplain. The floodplain is shown and labeled.
 - No part of the project site is located within the 100-year floodplain.
The 100-year floodplain boundaries are based on the following specific (including date of material) sources(s): FEMA FIRM Panel # 48491C0275E (effective date 9/26/2008).
36. The layout of the development is shown with existing and finished contours at appropriate, but not greater than ten-foot contour intervals. Lots, recreation centers, buildings, roads, etc. are shown on the site plan.
- The layout of the development is shown with existing contours at appropriate, but not greater than ten-foot contour intervals. Finished topographic contours will not differ from the existing topographic configuration and are not shown. Lots, recreation centers, buildings, roads, etc. are shown on the site plan.
37. A drainage plan showing all paths of drainage from the site to surface streams.
38. The drainage patterns and approximate slopes anticipated after major grading activities.
39. Areas of soil disturbance and areas which will not be disturbed.
40. Locations of major structural and nonstructural controls. These are the temporary and permanent best management practices.
41. Locations where soil stabilization practices are expected to occur.
42. Surface waters (including wetlands).
- N/A
43. Locations where stormwater discharges to surface water.
- There will be no discharges to surface water.
44. Temporary aboveground storage tank facilities.

- Temporary aboveground storage tank facilities will not be located on this site.
45. Permanent aboveground storage tank facilities.
 Permanent aboveground storage tank facilities will not be located on this site.
46. Legal boundaries of the site are shown.

Permanent Best Management Practices (BMPs)

Practices and measures that will be used during and after construction is completed.

47. Permanent BMPs and measures must be implemented to control the discharge of pollution from regulated activities after the completion of construction.
 N/A
48. These practices and measures have been designed, and will be constructed, operated, and maintained to insure that 80% of the incremental increase in the annual mass loading of total suspended solids (TSS) from the site caused by the regulated activity is removed. These quantities have been calculated in accordance with technical guidance prepared or accepted by the executive director.
 The TCEQ Technical Guidance Manual (TGM) was used to design permanent BMPs and measures for this site.
 A technical guidance other than the TCEQ TGM was used to design permanent BMPs and measures for this site. The complete citation for the technical guidance that was used is: _____.
 N/A
49. Owners must insure that permanent BMPs and measures are constructed and function as designed. A Texas Licensed Professional Engineer must certify in writing that the permanent BMPs or measures were constructed as designed. The certification letter must be submitted to the appropriate regional office within 30 days of site completion.
 N/A
50. Where a site is used for low density single-family residential development and has 20 % or less impervious cover, other permanent BMPs are not required. This exemption from permanent BMPs must be recorded in the county deed records, with a notice that if the percent impervious cover increases above 20% or land use changes, the exemption for the whole site as described in the property boundaries required by 30 TAC §213.4(g) (relating to Application Processing and Approval), may no longer apply and the property owner must notify the appropriate regional office of these changes.
 The site will be used for low density single-family residential development and has 20% or less impervious cover.
 The site will be used for low density single-family residential development but has more than 20% impervious cover.

The site will not be used for low density single-family residential development.

51. The executive director may waive the requirement for other permanent BMPs for multi-family residential developments, schools, or small business sites where 20% or less impervious cover is used at the site. This exemption from permanent BMPs must be recorded in the county deed records, with a notice that if the percent impervious cover increases above 20% or land use changes, the exemption for the whole site as described in the property boundaries required by 30 TAC §213.4(g) (relating to Application Processing and Approval), may no longer apply and the property owner must notify the appropriate regional office of these changes.

Attachment I - 20% or Less Impervious Cover Waiver. The site will be used for multi-family residential developments, schools, or small business sites and has 20% or less impervious cover. A request to waive the requirements for other permanent BMPs and measures is attached.

The site will be used for multi-family residential developments, schools, or small business sites but has more than 20% impervious cover.

The site will not be used for multi-family residential developments, schools, or small business sites.

52. **Attachment J - BMPs for Upgradient Stormwater.**

A description of the BMPs and measures that will be used to prevent pollution of surface water, groundwater, or stormwater that originates upgradient from the site and flows across the site is attached.

No surface water, groundwater or stormwater originates upgradient from the site and flows across the site, and an explanation is attached.

Permanent BMPs or measures are not required to prevent pollution of surface water, groundwater, or stormwater that originates upgradient from the site and flows across the site, and an explanation is attached.

53. **Attachment K - BMPs for On-site Stormwater.**

A description of the BMPs and measures that will be used to prevent pollution of surface water or groundwater that originates on-site or flows off the site, including pollution caused by contaminated stormwater runoff from the site is attached.

Permanent BMPs or measures are not required to prevent pollution of surface water or groundwater that originates on-site or flows off the site, including pollution caused by contaminated stormwater runoff, and an explanation is attached.

54. **Attachment L - BMPs for Surface Streams.** A description of the BMPs and measures that prevent pollutants from entering surface streams is attached.

N/A

55. **Attachment M - Construction Plans.** Construction plans and design calculations for the proposed permanent BMPs and measures have been prepared by or under the direct supervision of a Texas Licensed Professional Engineer, and are signed, sealed, and

dated. Construction plans for the proposed permanent BMPs and measures are attached and include: Design calculations, TCEQ Construction Notes, all proposed structural plans and specifications, and appropriate details.

N/A

56. **Attachment N - Inspection, Maintenance, Repair and Retrofit Plan.** A site and BMP specific plan for the inspection, maintenance, repair, and, if necessary, retrofit of the permanent BMPs and measures is attached. The plan fulfills all of the following:

Prepared and certified by the engineer designing the permanent BMPs and measures

Signed by the owner or responsible party

Outlines specific procedures for documenting inspections, maintenance, repairs, and, if necessary, retrofit.

Contains a discussion of record keeping procedures

N/A

57. **Attachment O - Pilot-Scale Field Testing Plan.** Pilot studies for BMPs that are not recognized by the Executive Director require prior approval from the TCEQ. A plan for pilot-scale field testing is attached.

N/A

58. **Attachment P - Measures for Minimizing Surface Stream Contamination.** A description of the measures that will be used to avoid or minimize surface stream contamination and changes in the way in which water enters a stream as a result of the construction and development is attached. The measures address increased stream flashing, the creation of stronger flows and in-stream velocities, and other in-stream effects caused by the regulated activity, which increase erosion that result in water quality degradation.

N/A

Responsibility for Maintenance of Permanent BMPs and Measures after Construction is Complete.

59. The applicant is responsible for maintaining the permanent BMPs after construction until such time as the maintenance obligation is either assumed in writing by another entity having ownership or control of the property (such as without limitation, an owner's association, a new property owner or lessee, a district, or municipality) or the ownership of the property is transferred to the entity. Such entity shall then be responsible for maintenance until another entity assumes such obligations in writing or ownership is transferred.

60. A copy of the transfer of responsibility must be filed with the executive director at the appropriate regional office within 30 days of the transfer if the site is for use as a

multiple single-family residential development, a multi-family residential development, or a non-residential development such as commercial, industrial, institutional, schools, and other sites where regulated activities occur.

Administrative Information

- 61. Submit one (1) original and one (1) copy of the application, plus additional copies as needed for each affected incorporated city, groundwater conservation district, and county in which the project will be located. The TCEQ will distribute the additional copies to these jurisdictions.
- 62. Any modification of this Contributing Zone Plan may require TCEQ review and Executive Director approval prior to construction, and may require submission of a revised application, with appropriate fees.
- 63. The site description, controls, maintenance, and inspection requirements for the storm water pollution prevention plan (SWPPP) developed under the EPA NPDES general permits for stormwater discharges have been submitted to fulfill paragraphs 30 TAC §213.24(1-5) of the technical report. All requirements of 30 TAC §213.24(1-5) have been met by the SWPPP document.
 - The Temporary Stormwater Section (TCEQ-0602) is included with the application.

Contributing Zone Plan Application (TCEQ-10257)

Attachment A: Road Map



Source: Google Earth Pro accessed 3/12/2024

Contributing Zone Plan Application (TCEQ-10257)

Attachment B: USGS Quadrangle Map FEMA FIRM Map Edwards Aquifer Recharge Zone Map

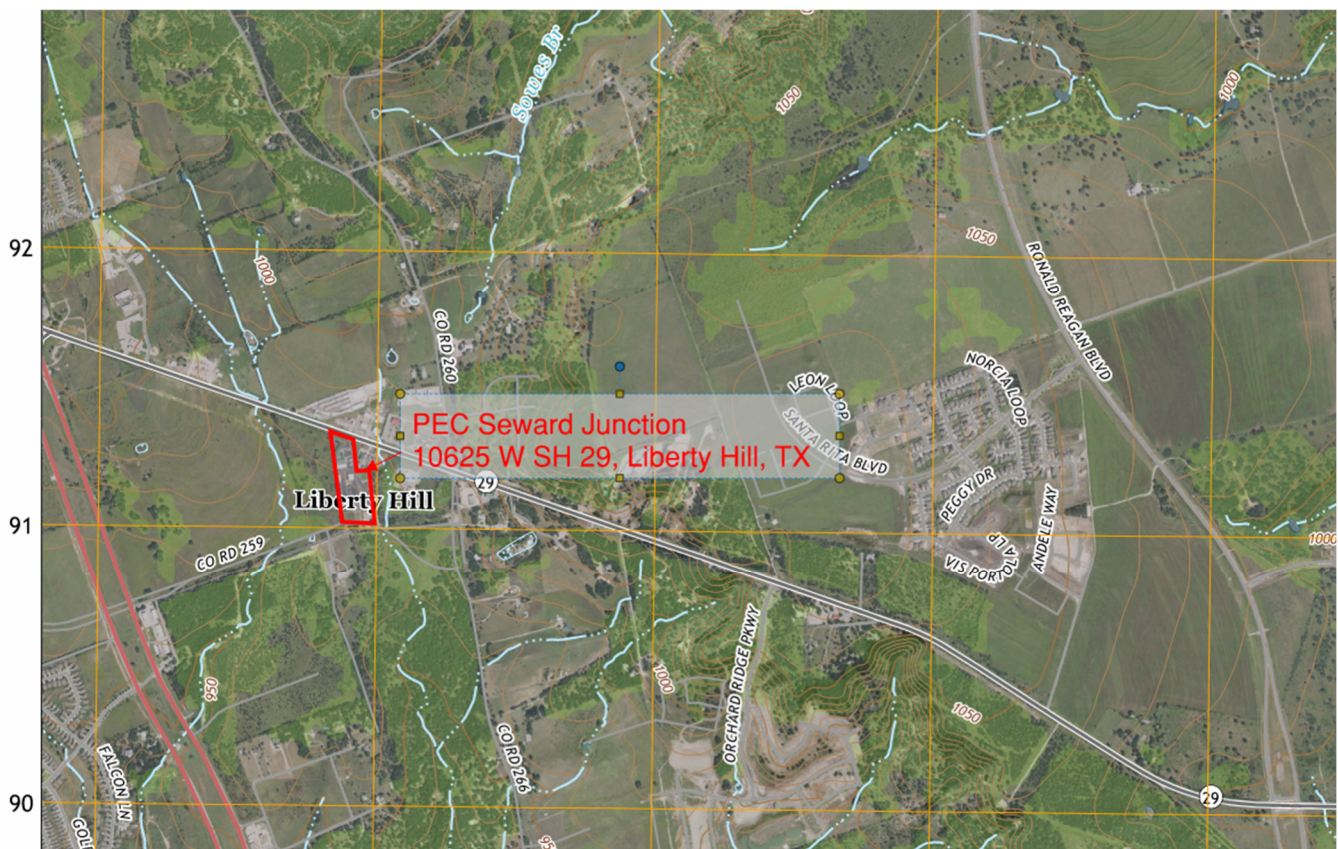

Source: Portion of USGS Quadrangle Map (TX_Leander_NE_20220808_TM_geo)

FEMA FIRM MAP PANEL

National Flood Hazard Layer FIRMette



Legend

SEE FIS REPORT FOR DETAILED LEGEND AND INDEX MAP FOR FIRM PANEL LAYOUT

SPECIAL FLOOD HAZARD AREAS

- Without Base Flood Elevation (BFE) Zone A, V, A99
- With BFE or Depth Zone AE, AO, AH, VE, AR
- Regulatory Floodway

OTHER AREAS OF FLOOD HAZARD

- 0.2% Annual Chance Flood Hazard. Areas of 1% annual chance flood with average depth less than one foot or with drainage areas of less than one square mile Zone X
- Future Conditions 1% Annual Chance Flood Hazard Zone X
- Area with Reduced Flood Risk due to Levee. See Notes. Zone X
- Area with Flood Risk due to Levee Zone D

OTHER AREAS

- NO SCREEN: Area of Minimal Flood Hazard Zone X
- Effective LOMRS
- Area of Undetermined Flood Hazard Zone D

GENERAL STRUCTURES

- Channel, Culvert, or Storm Sewer
- Levee, Dike, or Floodwall

CROSS SECTIONS

- 20.2: Cross Sections with 1% Annual Chance Water Surface Elevation
- 17.5: Coastal Transsect
- Base Flood Elevation Line (BFE)
- Limit of Study
- Jurisdiction Boundary

OTHER FEATURES

- Coastal Transsect Baseline
- Profile Baseline
- Hydrographic Feature

MAP PANELS

- Digital Data Available
- No Digital Data Available
- Unmapped

The pin displayed on the map is an approximate point selected by the user and does not represent an authoritative property location.

This map complies with FEMA's standards for the use of digital flood maps if it is not void as described below. The basemap shown complies with FEMA's basemap accuracy standards.

The flood hazard information is derived directly from the authoritative NFHL web services provided by FEMA. This map was exported on 3/12/2024 at 12:33 PM and does not reflect changes or amendments subsequent to this date and time. The NFHL and effective information may change or become superseded by new data over time.

This map image is void if the one or more of the following map elements do not appear: basemap imagery, flood zone labels, legend, scale bar, map creation date, community identifiers, FIRM panel number, and FIRM effective date. Map images for unmapped and unmodernized areas cannot be used for regulatory purposes.

Source: Portion of FEMA FIRMette Panel 48491C0275E (effective 9/26/2008)



Source: Portion of FEMA FIRM Map Panel 48491C0275E (effective 9/26/2008)

EDWARDS AQUIFER ZONE MAP

PEC Liberty Hill
10625 W SH 29
Liberty Hill, Texas 78642
Source: TCEQ Edwards Aquifer Viewer
Prepared: March 12, 2024

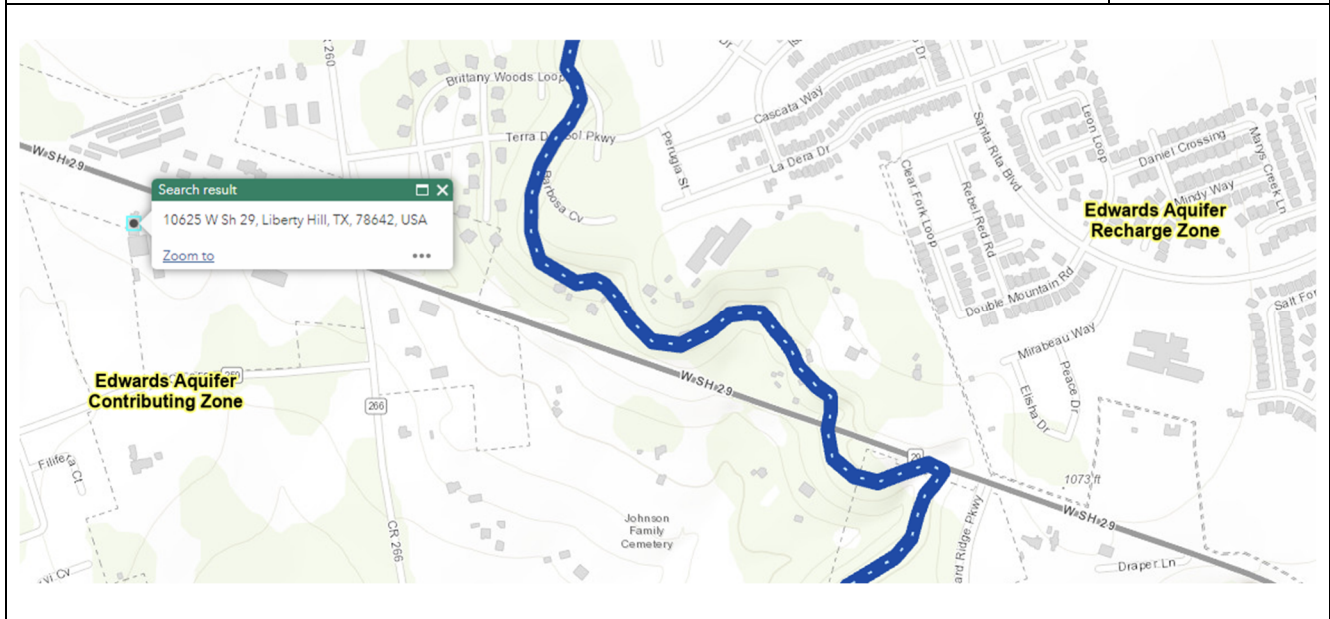



Contributing Zone Plan Application (TCEQ-10257)

Attachment C: Project Narrative

Proposed Development

The project site is located at 10625 W SH 29, Liberty Hill, Texas and is composed of two lots (6.22 AC & 2 AC) totaling 8.22 AC. The property is within the City limits of Liberty Hill, Texas, in Williamson County.

The proposed development is the addition of an Excell Aboveground Storage Tank (AST) fuel island on the existing caliche-based parking/storage area and one backup generator (150-gallon diesel). The fuel island will include the following:

1. One (1) 10,000 Gallon double-walled AST – split 7,000 gal Diesel/3,000 gal Gas UL 2085 Fireguard tank with rod ladder and e-vents
2. Two (2) 20-Gallon remote spill basins with 3” fill piping, 3” ball valves and 3” quick fill connections
3. Two (2) 2” X 3” overflow devices set at 90%
4. Two (2) DEF blue boxes with pulse output with external filters and 5-minute timers
5. Three (3) Centeron Cell Monitors with 500 call block
6. Franklin DEF nozzle and hose
7. One (1) Fuelmaster 6-hose FMS with network capable
8. One (1) 500-Gallon DEF Poly Tank

The fueling system will be backed up by a 150 gal. diesel generator.

The property is within the Edwards Aquifer Contributing Zone. The existing Contributing Zone Plan (CZP) (EAPP 11-08030503 approval letter dated 4/16/2008) and approved CZP Modification (EAPP 11001078 approval letter dated 5/23/2018) includes a sand filter basin Permanent BMP for stormwater water quality control located on Lot 3 (1.3069 AC) adjacent and south of Lot 2. The sand filter basin BMP was designed to meet the required 80% removal of the increased load in total suspended solids of the original project in 2008 (EAPP 11-08030503). The requested project modification does not increase the Impervious Cover (IC) at the site. The existing sand filter basin Permanent BMP continues to treat stormwater runoff at the site.

Site Description and History

The previously developed property is owned by Pedernales Electric Cooperative, Inc. (WCOPR Document # 2003039417). The legal descriptions are S8162 - Seward Junction Commercial Park, Lot 2, ACRES 6.22 (WCAD Parcel No. R431148). The facility currently serves as an operations center for the Pedernales



Electric Cooperative, including customer service and bill payment, storage of power poles, transformers, other utility construction and maintenance materials, and equipment.

The project site is on land with 0% - 15% slopes. Elevation at the project site is approximately between 975 FT and 985 FT. There is no vegetation at the project site, as the proposed construction is located on an existing parking lot area.

Access

Proposed access to the site is at 10625 W SH 29 in Liberty Hill, TX.

Impervious Cover (IC)

The impervious cover (IC) percentage on-site will not increase post-development. No change is proposed to the existing permanent BMP at the site.

Watershed and FEMA Floodplain Information

The project site is within the South Fork San Gabriel River Watershed, which drains to the Brazos River Basin. No surface streams run across the property. Drainage is generally to the southwest to an unnamed tributary that drains directly to the South Fork San Gabriel River, approximately 2.0 miles south of the project site.

The 6.22 AC property and 0.15 AC project site is in Zone X of FEMA FIRM Map No. 48491C0275E (effective 9/26/2008).

Temporary Best Management Practices (BMPs)

Construction practices shall disturb the minimal amount of existing ground cover as required for land clearing, grading, and construction activity for the shortest amount of time possible to minimize the potential of erosion and sedimentation from the site.

Prior to soil disturbing construction activity, temporary BMPs will be installed. Silt fencing will be installed along the down-gradient sides of the property to intercept and detain waterborne sediment from unprotected areas. The silt fence shall remain in place until the disturbed area is permanently stabilized.

Permanent Best Management Practices (BMPs)

No increased runoff or TSS will result from this fuel island and tank construction. The existing approved sand filter basin BMP for stormwater drainage and water quality at the developed site will continue to provide the required 80% reduction in stormwater sediments and be maintained according to the approved CZP (EAPP 11-08030503, dated April 16, 2008) and CZP Modification (EAPP 11001078, dated May 23, 2018). Total impervious cover (IC) at the property will not change as a result of the proposed construction of an AST and fueling island in the existing parking/storage area.



Offsite Areas

No offsite areas are anticipated to be affected by pre and post construction activities at the site. Temporary BMPs will minimize any anticipated effects of the proposed construction activities. The proposed development will not change the IC at the site. The existing permanent BMP currently addresses the impervious cover as shown within the construction plans.



**Contributing Zone Plan Application
(TCEQ-10257)**

**Attachment D:
Factors Affecting Surface Water Quality**

No surface water quality impacts are expected.



Contributing Zone Plan Application (TCEQ-10257)

Attachment E: Volume and Character of Stormwater

The proposed AST fueling site includes a double-walled AST fuel tank for secondary containment, and the fueling island is covered by a permanent constructed canopy. No change in the volume and character of stormwater at the site is expected.



**Contributing Zone Plan Application
(TCEQ-10257)**

**Attachment F:
Suitability Letter from Authorized Agent (if OSSF is proposed)
NOT APPLICABLE**



Contributing Zone Plan Application (TCEQ-10257)

Attachment G: Alternative Secondary Containment Methods (if AST with an alternative method of secondary containment is proposed)

The 10,000-gallon AST is a double-walled, split 10/3 UL 2085 Fireguard tank with rod ladder and e-vents. The double-walled tank construction provides the required secondary containment.



**Contributing Zone Plan Application
(TCEQ-10257)**

**Attachment H:
AST Containment Structure Drawings**

Table of contents:

- 1.) Site plan, TCEQ Notifications & tank schematic
- 2.) Gasboy Dispenser & Containment
- 3.) Hanging hardware and hose retractor
- 4.) Red Jacket submersible pump
- 5.) Diesel exhaust fluid equipment
- 6.) Emergency valves
- 7.) Remote fill connection and basin
- 8.) Product piping and flex connector
- 9.) FuelMaster fuel management unit
- 10.) NFPA Placards
- 11.) Emergency Stop button

1

6.22 ACRES
LOT 2 OF SEWARD JUNCTION
COMMERCIAL PARK SUBDIVISION

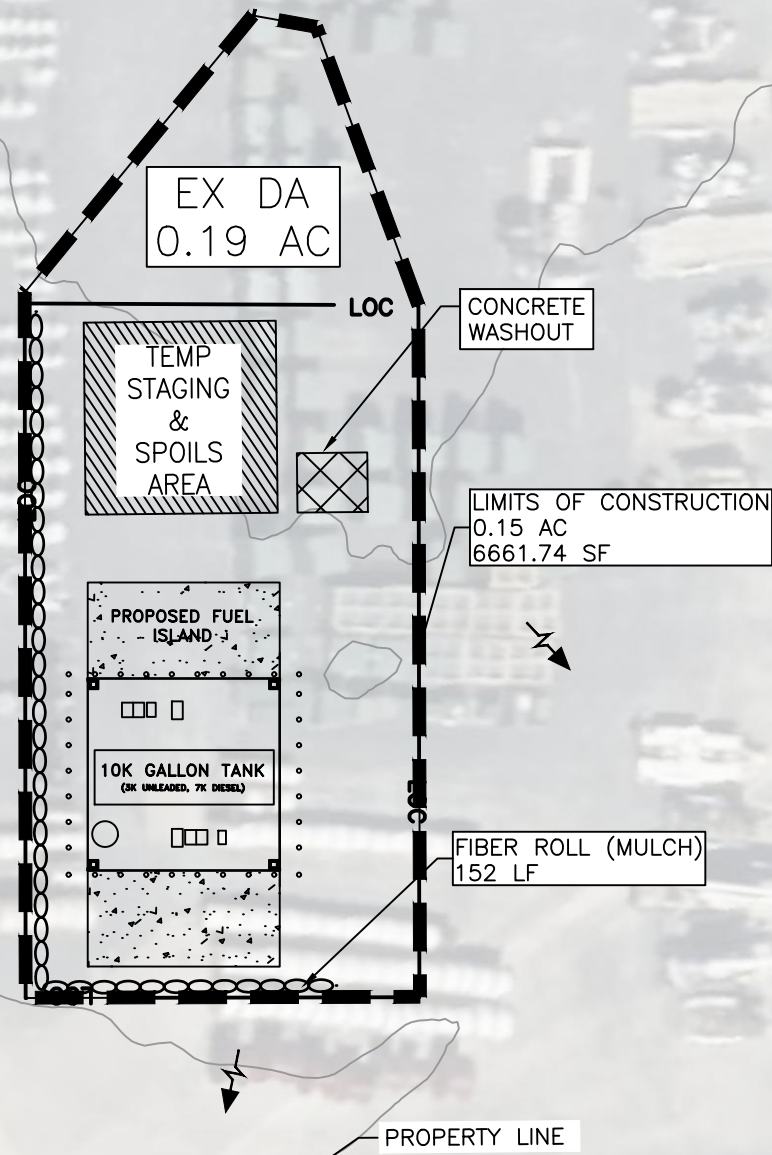

1.31 ACRES
LOT 3 OF SEWARD JUNCTION
COMMERCIAL PARK SUBDIVISION

EXISTING WATER QUALITY AND
DETENTION POND

REVISION RECORD

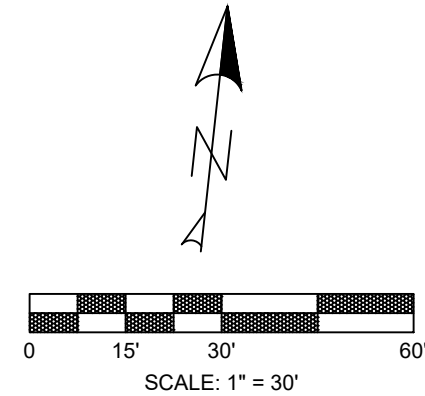

IF DRAWING BAR DOES NOT MEASURE 2"
THIS PRINT IS NOT TO SCALE

NOTES:

1. THIS PROJECT IS SUBMITTED WITHOUT PHASING.
2. ALL EXISTING IMPERVIOUS COVER AND DRAINAGE PATTERNS WILL REMAIN UNCHANGED POST-DEVELOPMENT.
3. CONTRACTOR TO CUT AND REMOVE CONCRETE AS NECESSARY TO REMOVE ALL EXISTING PIPING. REFER TO PLANS BY OTHERS FOR EXACT LOCATION OF DISPENSERS AND PIPING.
4. ALL REQUIRED NOTICES AND PERMITS MUST BE PLACED IN A HIGHLY VISIBLE LOCATION ONSITE BEFORE THE COMMENCEMENT OF CONSTRUCTION.
5. ALL EROSION AND SEDIMENTATION CONTROLS (ESC) MUST BE INSTALLED PRIOR TO ANY DISTURBANCE TO THE PROJECT SITE.
6. ALL ESC USED ONSITE MUST BE REGULARLY MONITORED AND MAINTAINED AS NEEDED.
7. THE STABILIZED CONSTRUCTION ENTRANCE SHALL BE MAINTAINED IN A CONDITION THAT PREVENTS TRACKING ONTO THE PUBLIC ROADWAY ON AN ONGOING/REGULAR BASIS. MUD AND OR DIRT TRACKED INTO THE ROADWAY MUST BE IMMEDIATELY REMOVED UPON DISCOVERY.
8. INLET PROTECTION SHALL BE INSTALLED IMMEDIATELY UPON INLET INSTALLATION.
9. INITIATE TEMPORARY STABILIZATION WHEN CONSTRUCTION CEASES IN A DISTURBED AREA FOR 14 DAYS.
10. INITIATE PERMANENT STABILIZATION IMMEDIATELY ONCE WORK HAS CEASED AND FINAL GRADE HAS BEEN ACHIEVED.
11. ALL DISTURBED/BARE AREAS WILL REQUIRE PERMANENT STABILIZATION BEFORE FINAL ACCEPTANCE CAN BE ACHIEVED. AVOID DISTURBING AREAS OF THE PROJECT THAT ARE NOT NECESSARY FOR CONSTRUCTION.
12. TEMPORARY ESC'S SHALL REMAIN IN PLACE IN ALL DISTURBED AREAS UNTIL ADEQUATE STABILIZATION HAS BEEN ACHIEVED.
13. THE TECHNICAL SPECS OF ESC DEVICES AND BEST MANAGEMENT PRACTICES (BMP) MEET OR EXCEED THE CITY OF AUSTIN ENVIRONMENTAL CRITERIA MANUAL.
14. PER PLANS BY OTHERS, EXISTING WATER QUALITY AND DETENTION POND HAS CAPACITY FOR AND WILL TREAT RUNOFF DURING CONSTRUCTION AND IN THE PROPOSED CONDITION.
15. NO INCREASED RUNOFF OR TSS WILL RESULT FROM THIS FUEL ISLAND AND TANK CONSTRUCTION.
16. IMPERVIOUS COVER PERCENTAGE ON-SITE WILL NOT INCREASE POST-DEVELOPMENT.

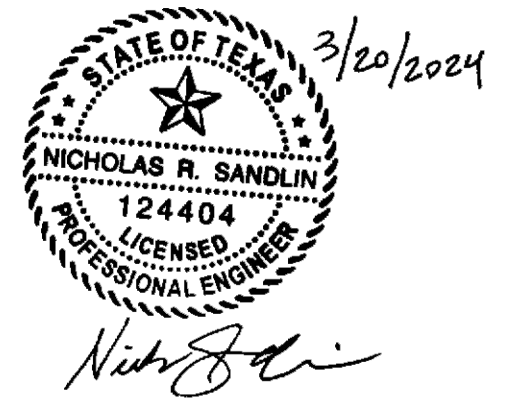

LEGEND

- PROPOSED PROPERTY/PROJECT BOUNDARY LINE
 - EXISTING R.O.W./PROPERTY LINE
 - EXISTING EASEMENT LINE
 - PROPOSED CURB & GUTTER LIMITS OF CONSTRUCTION
 - FIBER ROLL (MULCH)
 - STAGING & TEMPORARY SPOILS AREA
 - STABILIZED CONSTRUCTION ENTRANCE
 - CONCRETE WASHOUT
- NOTE: ADDITIONAL EROSION CONTROL MEASURES MAY BE REQUIRED BY INSPECTOR AT TIME OF CONSTRUCTION.
- DRAINAGE AREA BOUNDARY
 - DRAINAGE AREA DESIGNATION AND AREA DRAINED
 - FLOW ARROW

EROSION CONTROL AND DRAINAGE PLAN

SHEET 8 OF 10

P.E.C. LIBERTY HILL EAPP

EXCELL FUELING SYSTEMS

SANDLIN
SERVICES, LLC

TBPELS FIRM #21356
9111 JOLLVILLE RD., STE. 212
AUSTIN, TX 78759

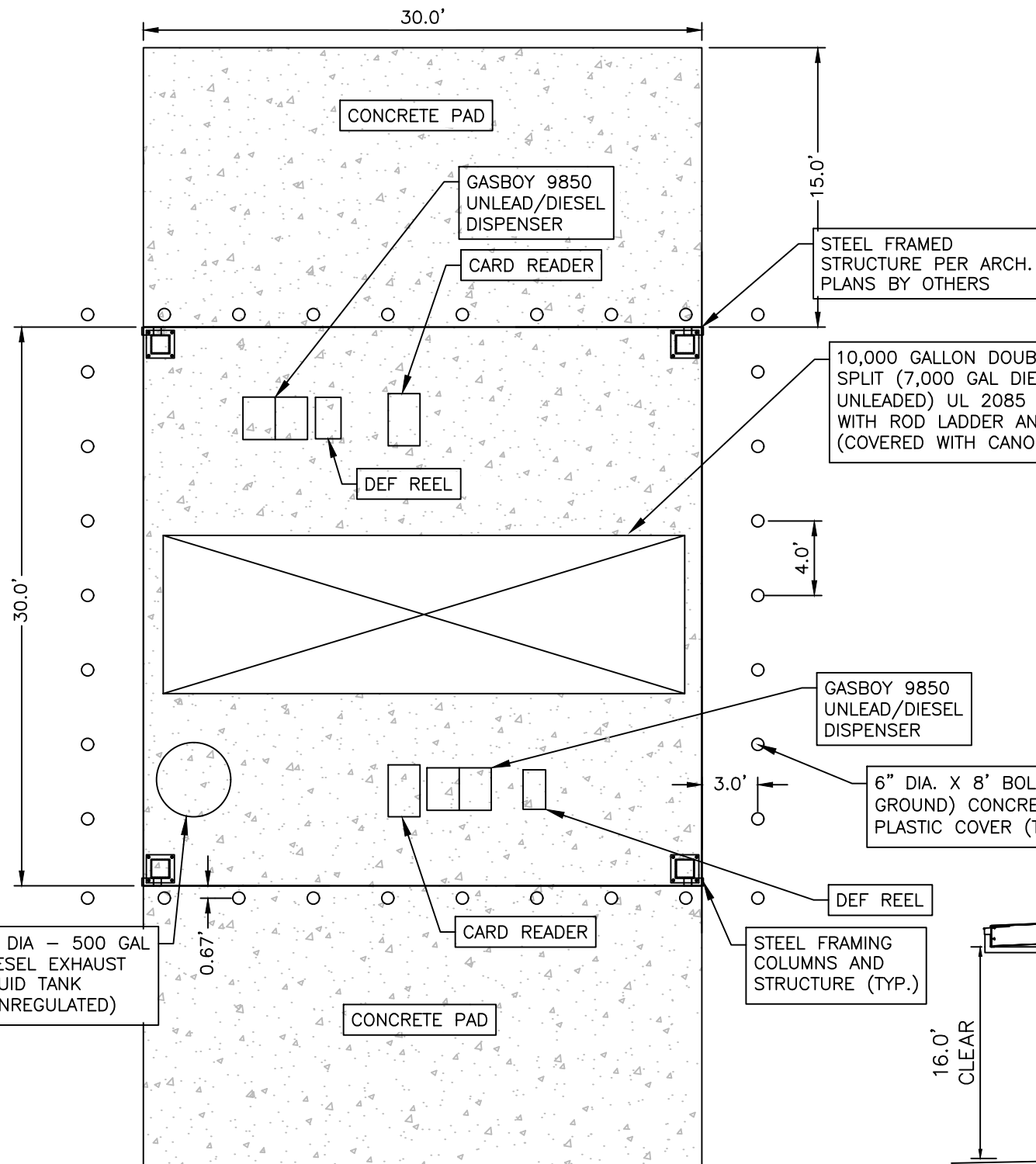

FUEL ISLAND PLAN
(N.T.S.)

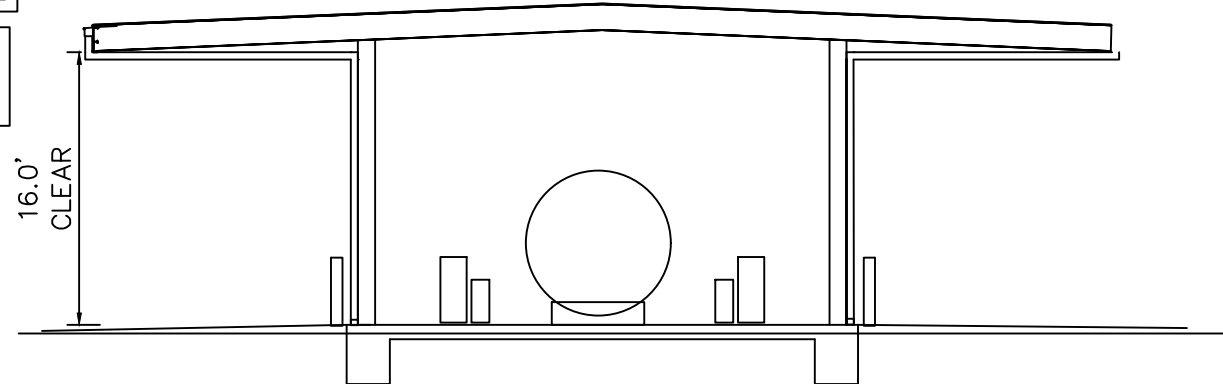

FUEL ISLAND ELEVATION
(N.T.S.)

NOTES

1. ALL PROPERTY BOUNDARIES ARE APPROXIMATE.
2. ABOVE GROUND STORAGE TANK SIZE AND SPECIFICATION TO BE PER AST APPLICATION TO TCEQ.
3. TANK LOCATION AND SIZE IS ESTIMATED AND WILL BE FIELD VERIFIED.
4. ALL TANKS SHOWN ARE DOUBLE WALLED AND THEREFORE HAVE THEIR OWN CONTAINMENT.
5. SEE ARCHITECTURAL PLANS FOR CANOPY DETAILS AND CONFIRMATION OF FUEL ISLAND DATA.

SEE PRODUCT DESCRIPTIONS FOR DETAIL, CONTAINMENT AND PROFILES

FUEL ISLAND SCHEDULE OF WORK

SUPPLY AND INSTALL THE FOLLOWING:

1. (1) 10,000 GALLON DOUBLE WALL TANK – SPLIT 10/3 UL 2085 FIREGUARD TANK WITH ROD LADDER AND E-VENTS.
2. (2) 20-GALLON REMOTE SPILL BASINS WITH 3" FILL PIPING. 3" BALL VALVES AND 3" QUICK FILL CONNECTIONS.
3. (2) 2" X 3" OVERFILL DEVICES SET AT 90%.
4. (2) DEF BLUE BOXES WITH PULSE OUTPUT WITH EXTERNAL FILTERS AND 5-MINUTE TIMERS.
5. (3) CENTERON CELL MONITORS WITH 500 CALL BLOCK.
6. FRANKLIN DEF NOZZLE AND HOSE.
7. (1) FUELMASTER 6-HOSE FMS WITH NETWORK CAPABLE.
8. ALL FITTINGS, HOSES AND NECESSARY INFRASTRUCTURE TO SUPPORT FUEL EQUIPMENT INSTALL AND OPERATION.

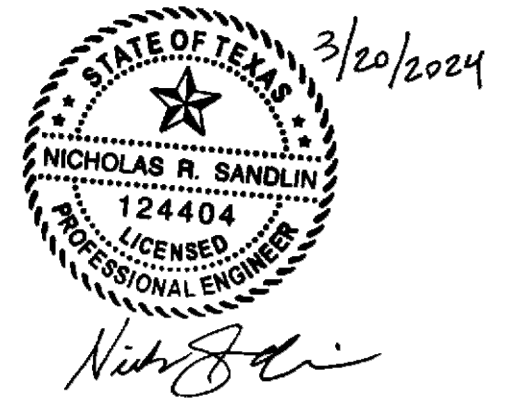

PROPERTY KEY MAP

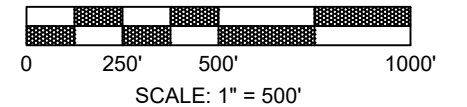

IF DRAWING BAR DOES NOT MEASURE 2" THIS PRINT IS NOT TO SCALE

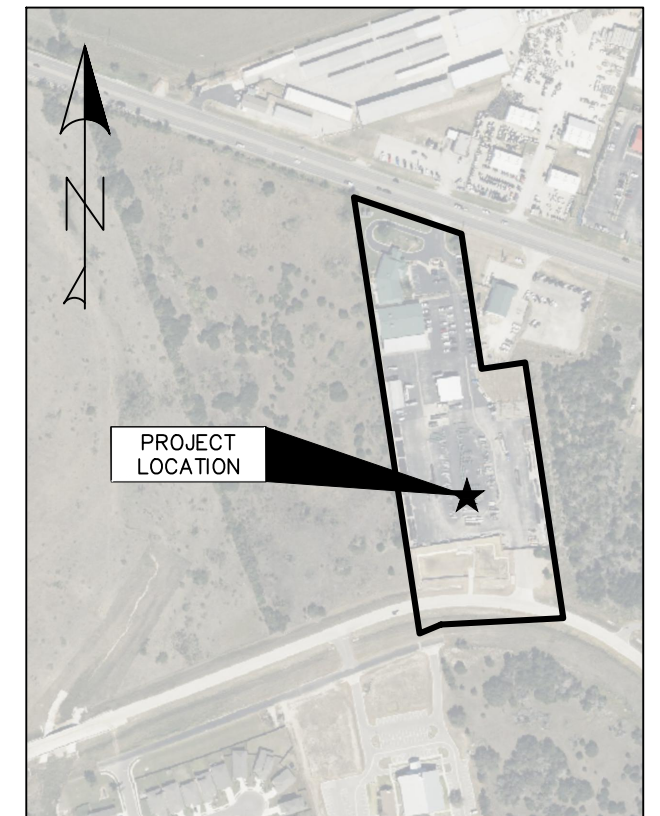

REVISION RECORD

AST TANK LAYOUT PLAN

SHEET 9 OF 10

P.E.C. LIBERTY HILL EAPP

EXCELL FUELING SYSTEMS

SANDLIN
SERVICES, LLC

TPELS FIRM #21356
9111 JOLLVILLE RD., STE. 212
AUSTIN, TX 78759

Note: This drawing may not be reproduced in any form without the written permission of Hughes Tank Company, Inc. Customer is responsible for verifying correctness of size, location of fittings, accessories and coatings shown on this drawing. Hughes Tank Company, Inc. shall be responsible only for the items indicated in this fabrication drawing unless otherwise noted.

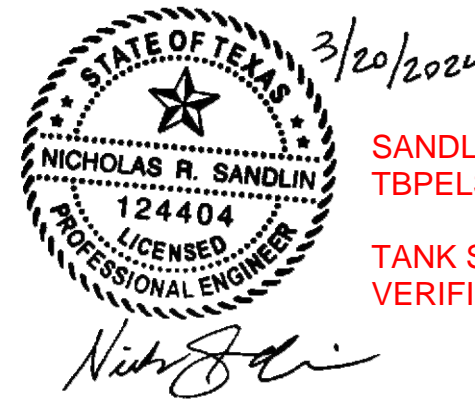
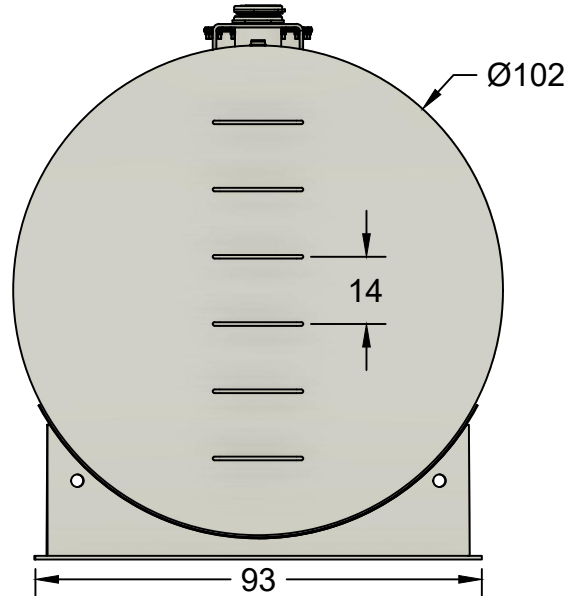
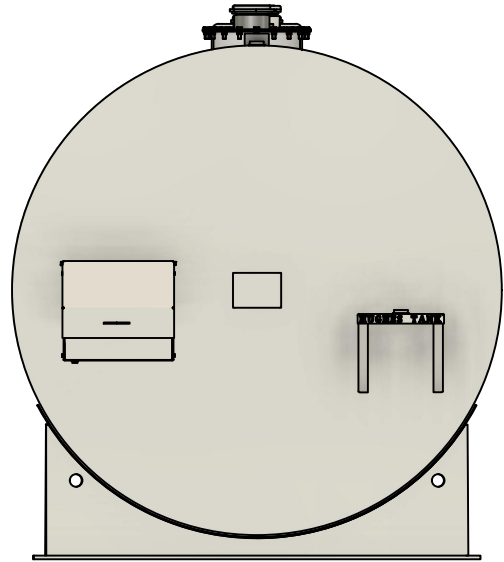
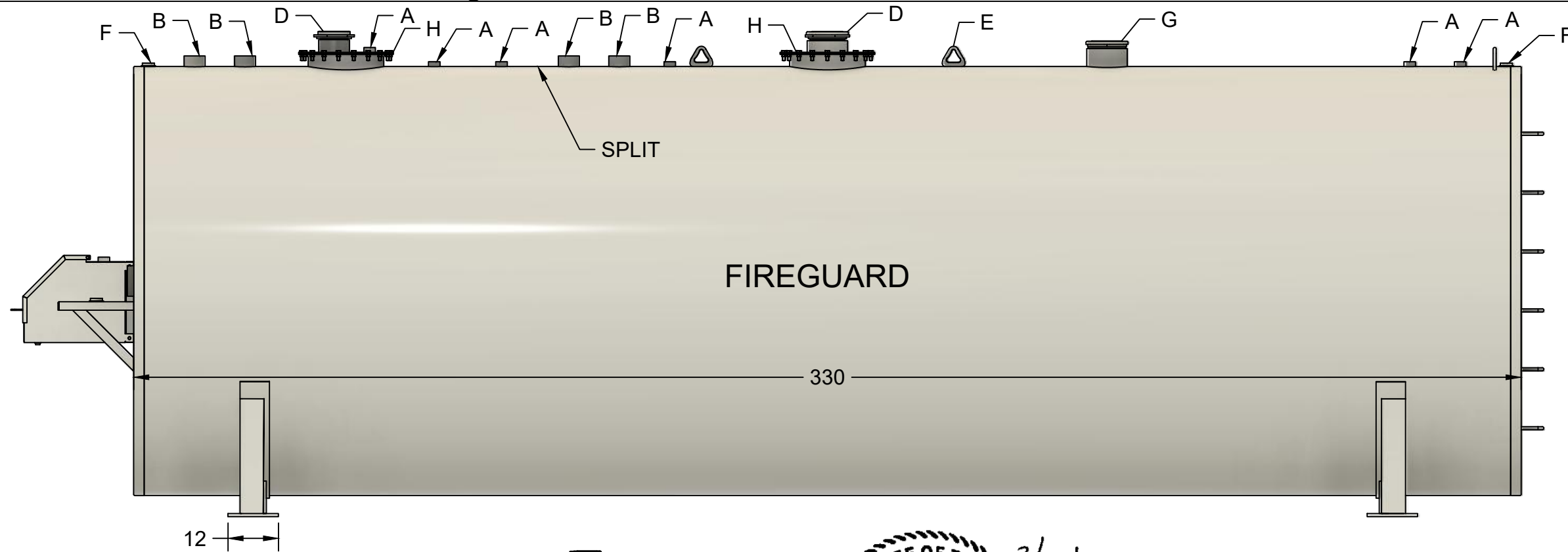

SANDLIN SERVICES, LLC
TBPELS - FIRM 21356

TANK SIZE AND DOUBLE WALL
VERIFICATION

- Inspection: Hughes Tank Company, Inc
 - Material: A36 Mild Carbon Steel
 - Internal: Surface prep - Clean of Debris
 - External: Surface prep - SSPC-SP6 (commercial blast)
 - External: (WHITE) Enviroastic 940 LV Polyurthane
 Test: Inner tank: 5PSIG Hydrostatic
 Outer tank: Hydrostatic
 Pressure Test: 3-5 PSI
 Labels: UL 2085
 This drawing may contain **CONFIDENTIAL** information and is intended **ONLY** for the use of the specific individual to which it is addressed.

CUSTOMER APPROVAL		A	B	C	D	E	F	G	H
SIGNATURE: _____		Coupling	Coupling	Coupling	Emergency Vent	Lifting Lug	Interstitial	Emergency Vent	Manhole
DATE: _____		2"	4"	6"	8"	Med.	2"	8"	18"
		2" threaded fitting	4" threaded fitting	6" threaded fitting	8" emergency vent	Medium lifting lug	2" interstitial fitting	8" emergency vent	18" manhole
		Primary	Primary	Primary	Primary	Secondary	Secondary	Secondary	Primary
Note: At no time shall the pressure in the secondary tank exceed the pressure in the primary tank.		CUSTOMER: EXCELL							
APPROVED Bobby Hughes		PROJECT: 7000/3000G UL 2085 SPLIT							
CHECKED Paige Hughes		WEIGHT		REV		SHEET 1/1			
DRAWN JD Hughes									



HUGHES TANK COMPANY, INC.

O: (972) - 366 - 8684
F: (972) - 366 - 3130

2900 N. FM 157
VENUS, TX 76084

P.O. BOX 570
VENUS, TX 76084

DESIGN: Fabricated per UL 2085 specifications double wall construction.

- Air test are no less than 3 PSI and no more than 5 PSI.
- Primary tank to be tested alone. Secondary tank to be pressure tested with primary tank. This shall be accomplished by bleeding air from the primary tank to the secondary tank.

2



GASBOY

FLEET & COMMERCIAL

FUELING



CONTENTS

Gasboy Overview	1
9853 Electronic High Flow	2
9850 Electronic Ultra-Hi	4
9216 Satellite	6
9862 Electronic DEF	8
9872 Electronic E85	10
Atlas PRIME	12
9153 Mechanical High Flow	14
9823 ASTRA Electronic AST	16
Model List	18
Features and Options	20

ATLAS SERIES

FUELING EQUIPMENT

Gasboy has been producing refueling equipment since the 1920's. The Atlas Series is the latest generation in a long line of fleet-fueling equipment and is the workhorse for the tough Fleet and Commercial environment. It's compatible with the Gasboy PLUS Fuel Management System or a wide range of third-party controllers.

The Atlas Platform Offers:

- A wide range of models and flow rates
- Sophisticated electronics or simple mechanical registers which cover all requirements
- Use in Underground Tanks (UST) or Aboveground Tanks (AST) applications

Common Features in the Atlas Platform Include:

- Rugged and welded G90 galvanized-steel frame
- Structural foam bezel with a clear polycarbonate window, and a backscreen polycarbonate dialface
- Field-wiring junction box for easy installation
- Replaceable sheathing — painted or optional 304 embossed stainless steel
- Standard hydraulics — compatible with traditional motor fuels such as Biodiesel (up to B20) and Ethanol (up to E15); custom models are available for E85, B100 or DEF
- Safety listed and with NTEP CoC for W&M sealing for fuel resale application
- Optional High Retrievers and Catlow's hanging hardware to complete your fleet fueling equipment

9853K

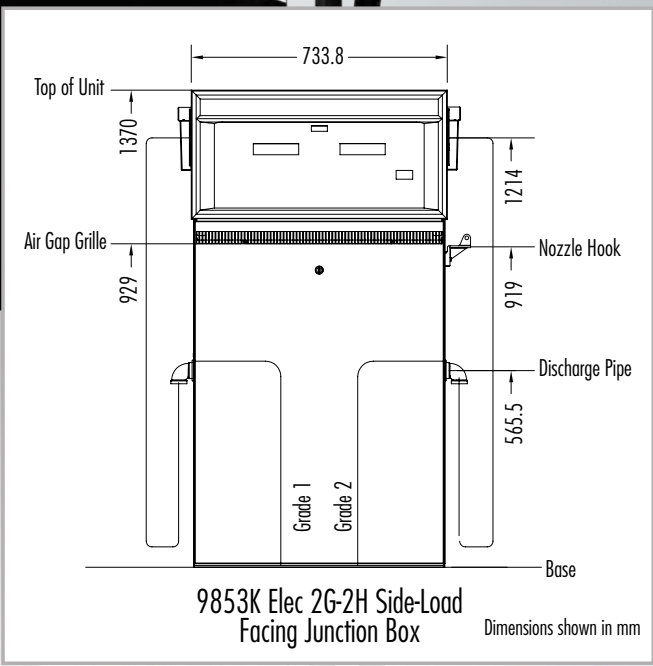

ATLAS 9853K

ELECTRONIC HIGH FLOW

Basic High Flow

The 9853K Series Basic High Flow Atlas has electronic displays. Available in a complete range of pump or dispenser style models. Versatile for most high-flow fleet fueling applications.

EASY USE	Large 1" LCD display with LED backlight and capacitor back up. LED lighting to identify fuel grade and illuminate the front panel.
FAST	High-flow rated at 22 gpm with side load or optional front load nozzle positions.
INTEGRATED	RS485 or Pulse Output interface for connectivity to Gasboy PLUS or other third-party site controllers.
DURABLE	Four-piston CFT meter with flow-through center chamber for harsh fuels. Large 1" internal piping for high flow rates in a variety of site conditions. Steel internal tubing on most models. 10-vane suction pump with 1-HP motor.
OPTIONS	Satellite piping option can turn your Atlas into a master / satellite fueling position.

ATLAS MODELS

G A S B O Y M O D E L S

Model Number	Description	Type	Hoses	Products	Register	Flow Rating
9153K						
9153K	Hi-flow Single Pump	Pump	1	1	Mech	22 gpm
9152KTW1	Std-flow Twin 1 Pump	Pump	2	1	Mech	15 gpm
9153KTW1M	Hi-flow Twin 1 Pump	Pump	2	1	Mech	22 gpm
9153KTW2	Hi-flow Twin 2 Pump	Pump	2	2	Mech	22 gpm
9153KX	Hi-flow Single Dispenser	Dispenser	1	1	Mech	22 gpm
9153KXTW1	Hi-flow Twin 1 Dispenser	Dispenser	2	1	Mech	22 gpm
9153KXTW2	Hi-flow Twin 2 Dispenser	Dispenser	2	2	Mech	22 gpm
9853K						
9853K	Hi-flow Single Pump	Pump	1	1	Elec	22 gpm
9852KTW1	Std-flow Twin 1 Pump	Pump	2	1	Elec	15 gpm
9853KTW1M	Hi-flow Twin 1 Pump	Pump	2	1	Elec	22 gpm
9853KTW2	Hi-flow Twin 2 Pump	Pump	2	2	Elec	22 gpm
9853KX	Hi-flow Single Dispenser	Dispenser	1	1	Elec	22 gpm
9853KXTW1	Hi-flow Twin 1 Dispenser	Dispenser	2	1	Elec	22 gpm
9853KXTW2	Hi-flow Twin 2 Dispenser	Dispenser	2	2	Elec	22 gpm
9840K						
9840K	Super-hi Single Pump	Pump	1	1	Elec	40 gpm
9840KX	Super-hi Single Dispenser	Dispenser	1	1	Elec	40 gpm

Model Number	Description	Type	Hoses	Products	Register	Flow Rating
9850K						
9850K	Ultra-hi Flow Single Pump	Pump	1	1	Elec	50 gpm
9850KTW3	Ultra-hi Flow Combo Pump	Pump Combo	2	1	Elec	50 gpm
9850KX	Ultra-hi Flow Single Disp	Dispenser	1	1	Elec	50 gpm
9850KXTW1	Ultra-hi Flow Twin 1 Disp	Dispenser	2	1	Elec	50 gpm
9850KXTW2	Ultra-hi Flow Twin 2 Disp	Dispenser	2	2	Elec	50 gpm
9850KXTW3	Ultra-hi Flow Combo Disp	Disp Combo	2	1	Elec	50 gpm
9862K						
9862KX-Z	DEF – Cold Weather	Dispenser	1	1	Elec	
9862KX-WW	DEF – Warm Weather	Dispenser	1	1	Elec	
9862KX-ZWW	DEF – Warm Weather	Dispenser	1	1	Elec	
9872K						
9872KX	E85 – Single	Dispenser	1	1	Elec	15 gpm
9872KXTW1	E85 – Twin 1	Dispenser	2	1	Elec	15 gpm
9823K						
9823K	ASTRA Split AST Pump	Pump	1	1	Elec	21 gpm
9216K						
9216K	Satellite	Satellite	1	1	None	
9216KTW	Satellite	Satellite	2	1	None	

ATLAS FEATURES

G A S B O Y M O D E L S

Feature	Short Description	9853	9840	9850	9823	9872	9862 CW	9862 WW	9153	9216
Approvals	Safety: UL and cUL Listed	S	S	S	S	S	MET	MET	S	S
	W&M: NCWM, Measurement Canada (MC)	S	S	S	S	S	S	S	S	S
Working Pressure	50 psi maximum	S	S	S	S	S	S	S	S	S
Operating Temp	-30°C to +55°C	S	S	S	S	S	S	-11°C	S	S
Unit of Measure	Gallons (liters optional)	S	S	S	S	S	S	S	S	—
Meter	Gilbarco 4 piston PD CFT Meter	S	S	—	S	S	—	—	S	—
	Liquid controls 6 step rotary PD Meter	—	—	S	—	—	—	—	—	—
	Coriolis Mass Flow Meter	—	—	—	—	—	S	S	—	—
Motors/Voltages	1 HP CD — 115V/60Hz (230V/50Hz optional)	S	S	—	S	—	—	—	S	—
	1½ HP CD — 115V/60Hz (230V/50Hz optional)	—	—	S	—	—	—	—	—	—
	¾ HP CD 380V/50Hz/3-phase	0	0	—	0	—	—	—	0	—
Pump Models	10 vane rotary w/air separator	S	S	—	S	—	—	—	S	—
	High speed rotary vane w/air separator	—	—	S	—	—	—	—	—	—
Solenoid Valve	2-stage valve for Preset Operation (PP)	1"	1½"	1½"	1"	1"	¾"	¾"	1"	1½"
Filters	Internal spin-on style (F)	S	S	Strainer	S	S	Strainer	Strainer	S	—
	External Canister Type	0	0	0	0	—	—	—	0	0
Piping	Internal Fuel Piping	1"	1½"	1½"	1"	1"	¾"	¾"	1"	1½"
Discharge	Hose Connection — NPT	1"	1¼"	1¼"	1"	¾"	1" BSPP	1" BSPP	1"	1¼"
Satellite Piping	Satellite piping connection (S) — disp only	0	0	0	—	—	—	—	0	—
Inlet	Island Connection — NPT	1½"	2"	2"	1½"	1½"	1" BSPP	1" BSPP	1½"	1½"
Junction Box	Field Wiring Junction Box	S	S	S	S	S	S	S	S	S
Housing	G90 Galvanized Steel	13 GA	13 GA	13 GA	11 GA	13 GA	13 GA	13 GA	13 GA	13 GA
	Lockable removable — Painted Galvanized Steel (std) — gauge	20	20	20	16	20	20	20	20	20
Panels	Lockable removable — Kooline Stainless Steel — 22 gauge	0	0	0	—	0	—	0	0	0
	Replaceable — Painted G60 Galvanized Steel (std) — gauge	20	20	20	16	20	20	20	20	20
Sheathing	Replaceable — Kooline Stainless Steel — 22 gauge	0	0	0	—	0	0	0	0	0

Feature	Short Description	9853	9840	9850	9823	9872	9862 CW	9862 WW	9153	9216
Computer/Register	Electronic Register — Volume only display	S	S	S	S	S	S	S	—	—
	Mechanical Register — VR10 volume only	—	—	—	—	—	—	—	S	—
Electronic Display	1" LCD w/LED Backlight & Capacitor Backup	S	S	S	S	S	S	S	—	—
Interface Options	Pulser — 10:1 or 100:1 volume (CC or CX)	—	—	—	—	—	—	—	0	—
	RS-485 — Gasboy CFN, Islander, or TopKat	0	0	0	0	0	0	0	—	—
	Pulse Output I/F	0	0	0	0	0	0	0	—	—
	DC conduit and junction box (D)	S	S	S	—	S	S	S	—	—
	Keytrol (EK)	—	—	—	—	—	—	—	0	—
TopKAT PLUS	TopKAT PLUS with Ethernet conduit (factory install)	0	0	0	—	0	0	0	—	—
Brand Panel Lighting	LED Lighted brand panel (L)	0	0	0	—	0	0	0	0	—
	Electronic	S	S	S	S	S	S	S	—	—
Totalizers	Non-resettable Electro-mechanical	0	0	—	—	0	0	0	—	—
	Non-resettable mechanical	—	—	0	0	—	—	—	S	—
Nozzle Position	Side load	S	S	S	—	S	—	S	S	—
	Front load (Z)	0	0	0	S	0	S	0	—	S
Hose Retractors	Internal hose retractor (I)	0	0	—	—	—	—	—	0	—
	Internal hose reel	—	—	—	—	—	S	—	—	—
	High hose retractor — external post mounted	0	0	0	0	0	—	0	0	0
AST Applications	Pressure Regulating Valve Model 52A — suction pumps only	0	—	—	0	—	—	—	0	—
	9850 Above Ground Tank Kit — suction pumps only	—	—	0	—	—	—	—	—	—
Warranty	12 month — Parts and labor	S	S	S	S	S	S	S	S	S
	Extended — 2, 3, 4 or 5 years	0	0	0	0	0	—	—	0	0
Miscellaneous	ATC (Canada only)	0	0	0	—	—	—	—	—	—
	Hand crank (K)	—	—	—	—	—	—	—	0	—
	Power reset	—	—	—	—	—	—	—	S	—
	Display power fail backup	S	S	S	S	S	S	S	—	—
	Internal cabinet heater (DEF only)	—	—	—	—	—	S	—	—	—
	Balanced vapor recovery	0	—	—	0	—	—	—	0	—
	Healy Universal Kit compatible	0	—	—	—	—	—	—	0	—
Hose, nozzle, swivel, breakaway	0	0	0	0	0	0	0	0	0	

S = Standard; 0 = Optional; — = not available



www.gasboy.com

P-7080 | 022217 | Gilbarco Veeder-Root | 7300 W. Friendly Ave., Greensboro, NC 27410

Model 434 Dispenser Pedestal

SPECIFICATION SHEET

Application

Dispenser pedestals serve as a raised platform for piping and installing dispensers/pumps in aboveground fueling systems.

Features and Details

- Provides containment for small leaks in dispenser piping
- AST pedestal sold with a dispenser specific mounting platform
- Dispenser pedestal less entry penetrations for desired placement in the field
- Pre-drilled anchor holes
- Dispenser mounting platform overhangs the pedestal base minimizing the ability for water penetration
- Stabilizer bar kits included
- Connection boots available
- Water tested liquid tight to the 6" level (18 gallon capacity)

Materials of Construction

434

- 12 gauge steel, powder coated black

434S

- 12 gauge 304 stainless steel

Certifications and Listings

Florida DEP EQ-823

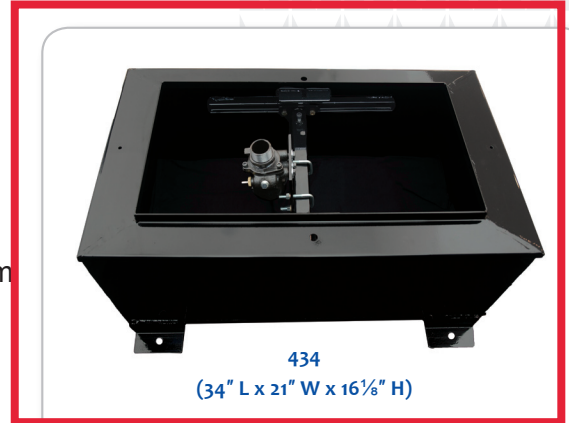

Specific item numbers and model details on next page.



Item Number	Description	Single (S) or Dual (D) Products	Opening Size (L x W)	Dispenser/Pedestal selection guide	Weight (lbs)
434--12001 AK	AST pedestal base, platform, & 1 stabilizer bar kit	S	14½" x 10"	Gasboy 215/216A	140.0
434--12002 AK	AST pedestal base, platform, & 2 stabilizer bar kits	D	14½" x 10"	Gasboy 215/216A	140.0
434--14001 AK	AST pedestal base, platform, & 1 stabilizer bar kit	S	22¼" x 12"	Gasboy Atlas 8700K, 8800K, 9100K, 9800K; Bennett Big Squirt/Big Fueler 3000 series (Pre August 2017)	125.70
434--14002 AK	AST pedestal base, platform, & 2 stabilizer bar kits	D	22¼" x 12"	Gasboy Atlas 8700K, 8800K, 9100K, 9800K; Bennett Big Squirt/Big Fueler 3000 series (Pre August 2017)	134.87
434--17001 AK	AST pedestal base, platform, & 1 stabilizer bar kit	S	28" x 15"	Wayne Century 3/G2200, Reliance G5200 and G6200, Select 3/G7200	122.20
434--17002 AK	AST pedestal base, platform, & 2 stabilizer bar kits	D	28" x 15"	Wayne Century 3/G2200, Reliance G5200 and G6200, Select 3/G7200	131.37
434S-14001 AK	SS AST pedestal base, platform, & 1 stabilizer bar kit	S	22¼" x 12"	Gasboy Atlas 8700K, 8800K, 9100K, 9800K; Bennett Big Squirt/Big Fueler 3000 series (Pre August 2017)	125.7
434S-14002 AK	SS AST pedestal base, platform, & 2 stabilizer bar kits	D	22¼" x 12"	Gasboy Atlas 8700K, 8800K, 9100K, 9800K; Bennett Big Squirt/Big Fueler 3000 series (Pre August 2017)	134.87
434S-17001 AK	SS AST pedestal base, platform, & 1 stabilizer bar kit	S	28" x 15"	Wayne Century 3/G2200, Reliance G5200 and G6200, Select 3/G7200	122.2
434S-17002 AK	SS AST pedestal base, platform, & 2 stabilizer bar kits	D	28" x 15"	Wayne Century 3/G2200, Reliance G5200 and G6200, Select 3/G7200	131.37

Accessories

Item Number	Size	Description	Weight (lbs)
434CB-0075 1B	¾"	Connection boot	0.22
434CB-0100 1B	1"	Connection boot	0.22
434CB-0150 1B	1½"	Connection boot	0.61
434CB-0200 1B	2"	Connection boot	0.62
434CBB0001 1B		Bonder, connection bond*	
434CBBA001 1A		Bond applicator, connection boot	
434SB-0100 AK		AST pedestal stabilizer bar kit	
434SSB0100 AK		AST pedestal stabilizer bar kit; stainless steel	
434VB-0100 AK		Valve mounting bracket for Tok-52 / F- 664 valve	

*One tube of bonder will cover three (3) connection boots.



3

Product Catalog



Elite 3/4" Series Automatic Nozzles



Max 1 Series of High Flow Automatic Nozzles



ICVN Vapor Recovery Nozzle



Controller II Swivel Breakaway

C720 Twister Swivel



C86NT Single Use Breakaway



CTM 75-HD HD Magnetic Breakaway

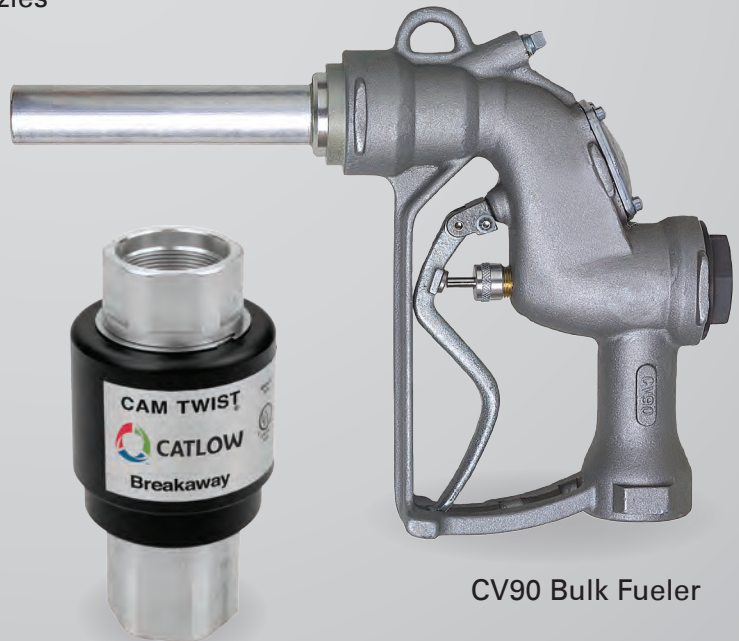

CV90 Bulk Fueler

Cam Twist VAC-Assist Recoverable Magnetic Breakaway





CATLOW

www.catlow.com

ELITE

Automatic Nozzle 3/4" NPT



ELITE Automatic Nozzle 3/4" NPT

STANDARD

This series of automatic nozzles establishes a new standard for vehicle refueling. The lightweight construction produces a smooth working, rugged nozzle designed for endurance.

The Elite Prepay is specifically designed for self-service or card-lock systems. The no-pressure/no-flow feature enables the station operator to control the dispensing of fuel while the customer has the convenience of a one hand hold-open mechanism for effortless dispensing.

FEATURES and BENEFITS:

- *UL/ULC Listed
- *Automatic shut off
- *Splash shield included with each new nozzle
- *Mates with all standard 5/8" & 3/4" hoses
- *BSPT and BSPP threads available upon request
- *Available in self serve upon request (S)
- *Available with an Attitude Device at an additional charge
- *Full cover provided for added protection
- *Spout assembly easily replaced
- *Completely rebuildable
- * Custom logo available upon request
- * 1 year warranty

MATERIALS:

- *3/4" Single body, sand cast aluminum
- *Lever & handguard is Super-Tuff Glass Filled Nylon
- *O-rings and Seals are Viton
- *Unleaded Spout Assembly 13/16" OD
- *Leaded Spout Assembly 15/16" OD
- *Weight 2.2 lbs.

CATLOW
 2750 US RT 40
 TIPP CITY, OHIO 45371 USA
 Phone (800) 222-8569 Fax (937) 898-8631
www.catlow.com

ORDERING SPECIFICATIONS

PART NUMBER	DESCRIPTION
NENL	NEW, UNLEADED
NEL	NEW, LEADED
NEPNL	NEW, PREPAY UNLEADED
NEPL	NEW, PREPAY LEADED
RENL	REBUILT, UNLEADED
REL	REBUILT, LEADED
REPNL	REBUILT, PREPAY UNLEADED
REPL	REBUILT, PREPAY LEADED

Accessories

PART NUMBER	DESCRIPTION
CNLS	ELITE UNLEADED SPOUT ASSEMBLY
CLS	ELITE LEADED SPOUT ASSEMBLY
CNLSP	PREPAY UNLEADED SPOUT ASSEMBLY
CLSP	PREPAY LEADED SPOUT ASSEMBLY
CFCxx	ELITE COVER xx
C11Bxx	ELITE PREPAY COVER xx
C376xx	ROUND SPLASH SHIELD xx





CATLOW

www.catlow.com

CAM TWIST MAGNETIC

In-Line Breakaway



CAMI TWIST Magnetic BREAKAWAY Standard Vapor Recovery

The CAM TWIST Breakaway is the only breakaway that gives you the option to easily disconnect, inspect and reconnect while installed. With a twist the breakaway can be taken apart and inspected for damage, corrosion, and wear without removing the breakaway from service.

Designed to be installed between the dispenser and the nozzle. It is simple to inspect the unit. Our unique design seals the internal components before a separation is complete, thus reducing any exposure to product and any environmental impact. With the CAM TWIST alignment and reconnection is easy. Align the two halves together & let the magnets do the work while pushing the unit back together. It's that easy!

CATLOW'S CAM TWIST MAGNETIC IN-LINE DESIGN IS THE FUTURE OF BREAKAWAY TECHNOLOGY!

As a cost saving feature, Catlow has designed a replacement lower half unit so in the event of a drive off, you only have to replace the lower half!

FEATURES and BENEFITS:

- * Inspectable, No "Remove-By" date
- * Patented Magnetic Snap-back Technology
- * Resists "Hydraulic Hammer" problems
- * UL/ULC Listed, CARB Certified, Meets NFPA 30A Codes
- * BSPP & BSPT threads available upon request
- * Separation force designed at 230 or 300 lbs.
- * Durable plastic cover prevents damage during a driveoff
- * Replacement "Lower" half of Breakaway available
- * Reduces Environmental Impact. No need to drain assemblies to change nozzle
- * One year warranty

MATERIALS:

- * Body is Aluminum
- * O-ring & Seals are Viton
- * Cover is Nylon

CATLOW
 2750 US RT 40
 TIPP CITY, OHIO 45371 USA
 Phone (800) 222-8569 Fax (937) 898-8631
www.catlow.com

ORDERING SPECIFICATIONS

PART NUMBER	DESCRIPTION
CTM75	3/4" NPT (230 LBS PULL FORCE)
CTM100	1" NPT (300 LBS PULL FORCE)
CTMVA	VAC-ASSIST M34 X 1.5 (230 LBS PULL FORCE)
CTM75-HD	3/4" NPT (300 LBS PULL FORCE)
CTM75-L	3/4" LOWER UNIT
CTM75HD-L	3/4" LOWER UNIT, HEAVY DUTY
CTM100-L	1" LOWER UNIT
CTMVA-L	VAC-ASSIST LOWER UNIT

Accessories

PART NUMBER	DESCRIPTION
A13-SW	8" WHIP HOSE FOR CTM75 or HD
B9-SW	12" WHIP HOSE FOR CTM100
V1012-1-SW	12" WHIP HOSE FOR CTMVA
2976	O'RING KIT CTM75
2978	O'RING KIT CTM75-HD/CTM100
2977	O'RING KIT CTMVA





CATLOW

www.catlow.com

C720

Twister Swivels



C720 TWISTER SWIVELS

Standard

Diesel

The Twister Swivel from Catlow raises the level of swivel flexibility with two (2) high flow 360 degree rotating swivel ends. Special seals protect this heavy duty swivel from extreme cold weather conditions and is designed for blended fuels.

Its high tech engineering, durable construction and economical price will not only "Twist & Turn" your hoses, but your profits as well.

FEATURES and BENEFITS:

- *Lightweight and maintenance free
- *UL/ULC listed
- *360 degree swivel rotation in middle joint & male end
- *Mates with all standard and diesel hoses
- *Fluorosilicone seals perform to -40 degree F
- *Does not affect existing hose length
- *BSPP & BSPT threads available upon request
- *Minimal flow restriction
- *Both swivel joints have double o-rings
- * 1 year warranty

MATERIALS:

- *Swivel elbow Cast Aluminum
- *Swivel body Cast ZA-12 Zamak
- *Bearing is Acetal
- *Seals are Viton and Fluorosilicone

ORDERING SPECIFICATIONS

PART NUMBER	DESCRIPTION
C720 3/4	3/4" M x 3/4" F
C720 1x3/4	1" M x 3/4" F
C720 1x1	1" M x 1" F
C720 1X1B100	1" M X 1" F 100% BIO DIESEL FUEL
C720 1X1BP	1" M X 1" F BRITISH THREAD
C720 3/4BP	3/4" M X 3/4" F BRITISH THREAD
C720 3/4E85	3/4" M X 3/4" F E85 FUEL
C720 1X1E85	1" M X 1" F E85 FUEL

C720-3/4 SWIVEL

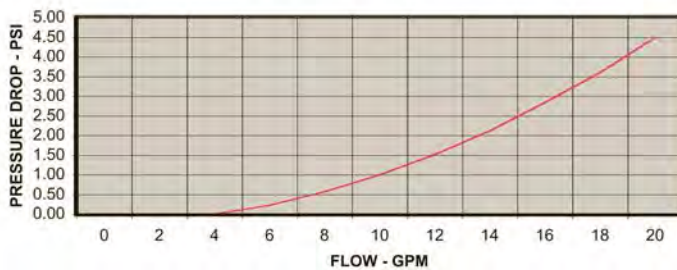

C720-1 SWIVEL

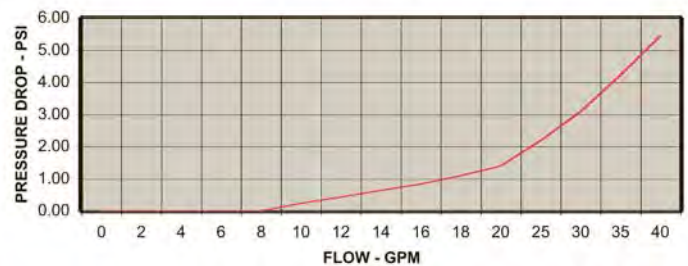

CATLOW
 2750 US RT 40
 TIPP CITY, OHIO 45371 USA
 Phone (800) 222-8569 Fax (937) 898-8631
www.catlow.com





CATLOW

www.catlow.com

The MAX 1 Hi-flow diesel nozzle is designed for durability. This heavy-duty nozzle can be used in high volume truckstop applications as well as high volume service stations.

Available as a standard or prepay (no pressure/no flow) nozzle. The prepay nozzle is specifically designed for unattended self service and cardlock refueling locations. The prepay feature enables the station operator to control the dispensing of fuel.

FEATURES and BENEFITS:

- * Available as full serve or self serve
- * Rugged heavy duty design
- * Automatic shut-off
- * UL/ULC Listed
- * Custom logo available upon request
- * BSPP and BSPT threads available upon request
- * Attitude Device available upon request (AD)
- * Spout assembly easily replaced
- * Full Cover provided for added protection
- * Longer spout with Anchor Bushing available upon request (AR)
- * One-hand, hold open mechanism for effortless operation
- * Mates with all standard hardwall or softwall 1" hoses
- * Completely rebuildable
- * One year warranty

MATERIALS:

- * Body is Sand cast Aluminum
- * Lever/Handguard Super-Tuff glass filled Nylon
- * Seals are Viton
- * Spout is 1-3/16" OD Aluminum Spout
- * Weight 4 lbs.

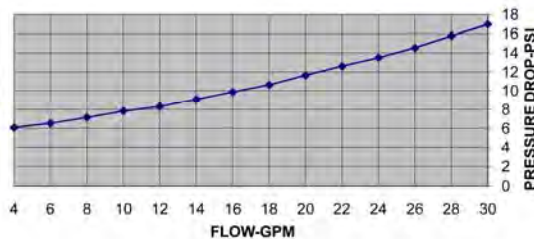

CATLOW
 2750 US RT 40
 TIPP CITY, OHIO 45371 USA
 Phone (800) 222-8569 Fax (937) 898-8631
www.catlow.com

MAX1

Automatic DIESEL Nozzle



MAX1 Automatic Nozzle

Diesel

ORDERING SPECIFICATIONS

PART NUMBER	DESCRIPTION
NM1	NEW, DIESEL
NM1P	NEW, DIESEL PREPAY
NM1S	NEW, DIESEL SELF SERVE
NM1PS	NEW, DIESEL SELF SERVE, PREPAY
RM1	REBUILT, DIESEL
RM1P	REBUILT, DIESEL PREPAY

Accessories

PART NUMBER	DESCRIPTION
BS	DIESEL SPOUT ASSEMBLY
BS-P	DIESEL SPOUT ASSEMBLY PREPAY
C180 xx	COVER xx identifies color i.e. BK Black
C076 xx	SPLASH SHIELD xx identifies color i.e. BK





CATLOW

TERMS AND WARRANTY

Rebuilt Nozzles:

Rebuilt Nozzles are invoiced at exchange price, and terms: Net 30 Days from invoice date. A separate invoice will be issued for core charges. Nozzle cores may be returned within sixty (60) days from invoice date to receive full credit against the core charge invoice.

Terms and Service Charge:

The terms for approved accounts: Net 30 Days on all orders. Terms for core charges: 60 Days Net. A service charge of 1 1/2% per month - 18% annual rate - will be added to all past due accounts.

Freight:

Freight is prepaid when net order to one destination is greater than:
\$2,500 All shipments within the continental USA
\$3,000 All International & Canadian shipments

Minimum Purchase: (Repair parts are an exception)

\$100.00 per order: All shipments within the continental USA
\$500.00 per order: All International & Canadian shipments

Remittance Address:

Please use this address for Remittance ONLY

VEEDER ROOT COMPANY
P.O. Box 99502
Chicago, IL 60693-9502

Limited Warranty:

CATLOW expressly warrants that its products shall be free from defects in materials and workmanship for a period of one year from the date of manufacture. This warranty is limited to repair or replacement by CATLOW upon return of the product to the CATLOW factory. This warranty does not apply in the event of any misuse or neglect of the product. The foregoing warranty is the exclusive remedy of purchasers of CATLOW products. CATLOW expressly disclaims any warranties, other than the foregoing express warranty, including the implied warranties of merchantability and fitness for a particular purpose, and disclaims any and all liability for consequential damages resulting from the use of its products.

Warranty Procedure:

All nozzles returned under warranty within 60 days, will be replaced with a new product. If the nozzle is dated beyond 60 days, it will be replaced with a rebuilt nozzle that carries the same warranty. The only exceptions are vapor recovery nozzles. If the nozzle returned to us was originally purchased as a new or rebuilt, that is what will be sent as a replacement.

Vapor recovery nozzles must have the "Nozzle Warranty Tag" completed and returned with the nozzle for the warranty to be honored. VERY IMPORTANT You must include the replacement serial number on the tag for the warranty to be honored. Without the tag, the warranty will not be honored. In addition to this, the vapor recovery nozzle replacement serial number will replace the serial number of the nozzle sent to us under warranty. We will be prorating the remaining warranty on the replacement nozzle.

Returned Goods:

Resalable material of standard manufacture must not be returned without first receiving a Return Goods Authorization number. Products accepted for return must be in first class condition, resalable as new and shipping charges prepaid. Minimum handling charge is 20% deducted from the price paid by the customer, or current price, whichever is lower.

All items shipped to Catlow must have a Returned Goods Authorization number (RGA).

**Sales Desk (800) 222-8569 - Sales Fax (937) 898-8631 - Phone (937) 898-3236
2750 US RT 40, Tipp City, OH 45371**



Proven Performance Since 1932.



HOSE RETRIEVER

HOSE RETRACTOR - COUNTERWEIGHT

Application -

Keeping conventional and Stage II vapor recovery coaxial hoses raised to prevent traps in the vapor line. Potential accidents are reduced. Hose life is greatly extended.

Part Number - 880/882



UNIVERSAL Advantage

Only from Universal! - Our better looking profile blends in with today's modern dispensers.

Features -

- ✓ Easy to install and maintain
- ✓ Adaptable to most dispensers
- ✓ Corrosion resistant construction
- ✓ Plastic bushing minimizes cable wear
- ✓ Compatible with E-85

Construction -

- Aluminum Post (2"x2")
- Cast iron counterweight
- Plastic bushings
- Black polyester cable
- Includes both side and bottom mounting brackets

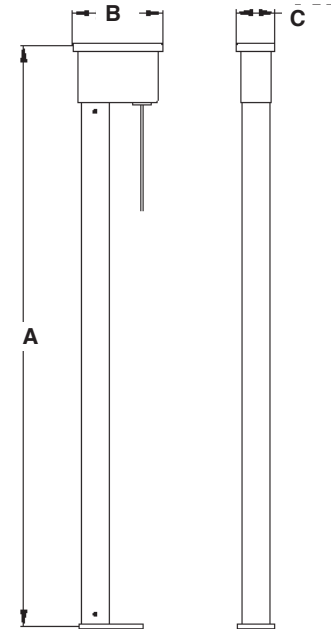

Model	Weight (lbs.)	A	B	C	Counter Weight
880	29	78-3/4"	5-1/2"	2-1/4"	20lbs
882	38	92"	5-1/2"	2-1/4"	27lbs

Replacement Parts

Part Numbers	Description	Part Numbers	Description
880-5	Cover Pulley	880-MBC	Square Bracket
880-8	Bushing	880-WA	Weight Assembly (1-1/2" x 1-1/2")
880-8A	Black Nylon Rope	880-WA-2	Weight Assembly (882) (1-3/4" x 1-3/4")
880-A	Body	880-AC	Body Assembly
880-B	Base	880-CA	Cover Assembly
880-C	Cover		

*Custom heights and counterweights available. Call for options.

Notice: Universal Valve Co., products must be used in compliance with applicable federal, state, and local laws and regulations. Product selection should be based on physical specifications and limitations and compatibility with the environment and material to be handled. Universal Valve Co., makes no warranty of fitness for a particular use. All illustrations and specifications in this literature are based on the latest production information available at the time of publication. Prices, materials, and specification are subject to change at any time, and models may be discontinued at any time, in either case, without notice or obligation.

UNIVERSAL VALVE COMPANY

478 Schiller Street, Elizabeth, NJ 07206 • (800) 223-0741 • (908) 351-0606 • Fax: (908) 351-0369 • universalvalve.com

© 2018 Universal Valve Company, Inc.

4



The Red Jacket Submersible Turbine Pump

The cornerstone of your fueling infrastructure. The Red Jacket series submersible turbine pump is the foundation model that sets the standard for high throughput, high reliability fueling applications.

Specifications:

Fuel Compatibility

- 100% Diesel
- 100% Gasoline
- Methanol concentrations up to 20%
- Ethanol concentrations up to 20%
- MTBE, ETBE, or TAME concentrations up to 20%

Designed for Hazardous Locations

- Class 1, Group D atmospheres

Fits installations from 3 ½ to 19' in depth

4 Motor Sizes Available:

- ¾ HP, 60 Hz, 1 – phase
- 1 ½ HP, 60 Hz, 1 – phase
- X3 1 ½ HP, 60 Hz, 1 – phase, high pressure
- 2 HP, 60 Hz, 1 – phase

All models available with floating suction adapter

Automatic electrical disconnect plus fuel drain to assist in safe servicing

Key Features:

- Industry's newest motor design
- Track record of unsurpassed reliability
- Designed to maximize safety and ease installation

Siphon Ports:

- 2 available, ¼" NPT
- Vacuums generated up to 25 in Hg.

Compatible with check valve housing models:

- Standard VR ready check valve for PLLD (410152-001)
- High pressure check valve for high pressure applications (410152-002)

Line Pressure Port: 1 Available, ¼" NPT

Vent Port: 1 Available, ¼"NPT

UL Listings:

- 100% Diesel
- 100% Gasoline
- Gasoline and up to: 10% Ethanol, 15% Methanol, 20% MTBE, 20% ETBE, 20% TAME

Other Agency Listings: cUL

Optional stainless steel trapper intake screen blocks corroded tank debris from clogging dispenser filters

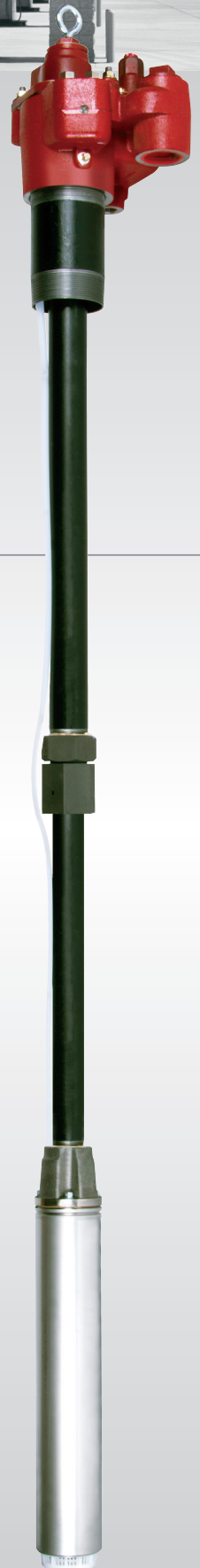

Quick Set Final Assemblies (Adjustable)

Horsepower	KW	Length	Floating Suction Adapter	Model Number	Part Number
0.75	0.56	72" - 102"		P75U1 RJ1	410140-001
0.75	0.56	102" - 162"		P75U1 RJ2	410140-002
0.75	0.56	162" - 222"		P75U1 RJ3	410140-003
0.75	0.56	74.3" - 104.3" *	•	P75U1 RJ1 FSA	410140-004
0.75	0.56	104.3" - 164.3" *	•	P75U1 RJ2 FSA	410140-005
0.75	0.56	164.3" - 224.3" *	•	P75U1 RJ3 FSA	410140-006
1.5	1.13	74.5" - 105"		P150U1 RJ1	410141-001
1.5	1.13	104.5" - 165"		P150U1 RJ2	410141-002
1.5	1.13	164.5" - 225"		P150U1 RJ3	410141-003
1.5	1.13	76.8" - 107.3"	•	P150U1 RJ1 FSA	410141-004
1.5	1.13	106.8" - 167.3"	•	P150U1 RJ2 FSA	410141-005
1.5	1.13	166.8" - 227.3"	•	P150U1 RJ3 FSA	410141-006
1.5	1.13	75.5" - 105.5"		X3P150U1 RJ1	410143-001
1.5	1.13	105.5" - 165.5"		X3P150U1 RJ2	410143-002
1.5	1.13	165.5" - 225.5"		X3P150U1 RJ3	410143-003
1.5	1.13	77.8" - 107.8"	•	X3P150U1 RJ1 FSA	410143-004
1.5	1.13	107.8" - 167.8"	•	X3P150U1 RJ2 FSA	410143-005
1.5	1.13	167.8" - 227.8"	•	X3P150U1 RJ3 FSA	410143-006
2	1.5	78.5" - 108.5"		P200U1-3 RJ1	410142-001
2	1.5	108.5" - 168.5"		P200U2-3 RJ1	410142-002
2	1.5	168.5" - 228.5"		P200U3-3 RJ1	410142-003
2	1.5	80.8" - 110.8"	•	P200U1-3 RJ1 FSA	410142-004
2	1.5	110.8" - 170.8"	•	P200U1-3 RJ2 FSA	410142-005
2	1.5	170.8" - 230.8"	•	P200U1-3 RJ3 FSA	410142-006

Fixed-Speed, single phase STP assemblies. Length measured from the top of the eyebolt to the bottom of the motor inlet. All 208/230 Volts.

Fixed Length Final Assemblies (Non-Adjustable)

Horsepower	KW	Length	Floating Suction Adapter	Model Number	Part Number
0.75	0.56	42" - 132"		P75U1 RJ	410166-001
0.75	0.56	133" - 168"		P75U2 RJ	410166-002
0.75	0.56	169" - 222"		P75U3 RJ	410166-003
0.75	0.56	44.3" - 134.3"	•	P75U1 RJ FSA	410166-019
0.75	0.56	135.3" - 168.2"	•	P75U1 RJ FSA	410166-020
0.75	0.56	171.3" - 224.3"	•	P75U1 RJ FSA	410166-021
1.5	1.13	45" - 135"		P150U1 RJ	410173-001
1.5	1.13	136" - 171"		P150U1 RJ	410173-002
1.5	1.13	172" - 225"		P150U1 RJ	410173-003
1.5	1.13	47.3" - 137.3"	•	P150U1 RJ FSA	410173-019
1.5	1.13	138.3" - 173.3"	•	P150U1 RJ FSA	410173-020
1.5	1.13	174.3" - 227.3"	•	P150U1 RJ FSA	410173-021
1.5	1.13	46" - 135"		X3P150U1 RJ	410175-001
1.5	1.13	136" - 171"		X3P150U1 RJ	410175-002
1.5	1.13	172" - 225"		X3P150U1 RJ	410175-003
1.5	1.13	48.3" - 137.3"	•	X3P150U1 RJ FSA	410175-019
1.5	1.13	138.3" - 173.3"	•	X3P150U1 RJ FSA	410175-020
1.5	1.13	174.3" - 227.3"	•	X3P150U1 RJ FSA	410175-021
2	1.5	49" - 138"		P200U1-3 RJ	410174-001
2	1.5	139" - 174"		P200U1-3 RJ	410174-002
2	1.5	175" - 228"		P200U1-3 RJ	410174-003
2	1.5	51.3" - 140.3"	•	P200U1-3 RJ FSA	410174-019
2	1.5	141.3" - 176.3"	•	P200U1-3 RJ FSA	410174-020
2	1.5	177.3" - 230.3"	•	P200U1-3 RJ FSA	410174-021

Fixed length pumps may not be returned to stock.



To learn more, contact us at 888.561.7942 or visit www.redjacket.com

5



DISPENSERS



PUMPS



METERS



METERED NOZZLES



NOZZLES

DEF BLUE BOX PEDESTAL

FEATURES

- EASY TO INSTALL
- READY TO USE
- BUILT-IN LOCK

The PIUSI DEF Blue Box Pedestal is specifically designed for wall or tank installation, or can be mounted atop an optional pedestal. It is covered by a lockable metal container which protects the pump when not in use.

PERFORMANCE

UP TO

9 GPM

FLOW RATE

AC V. / Hz

120/60

VOLTAGE

POWER

± 1%

ACCURACY

20 MIN

DUTY CYCLE



DEF BLUE BOX PEDESTAL (FULLY ASSEMBLED)



PACKAGING (BLUE BOX)

PART #	WEIGHT		PACKAGING		
	KG	LBS	MM	INCH	PCS/BOX
R1611800A	25	55.1	575X320X607	22.6X23.9	1



FILTRATION



FLUID MONITORING



HOSE REELS



ACCESSORIES



AIR



ANTIFREEZE



DEF



BIODIESEL



DIESEL



FOOD



GASOLINE



GREASE



KEROSENE



OIL



WATER



WINDSCREEN

CHARTS

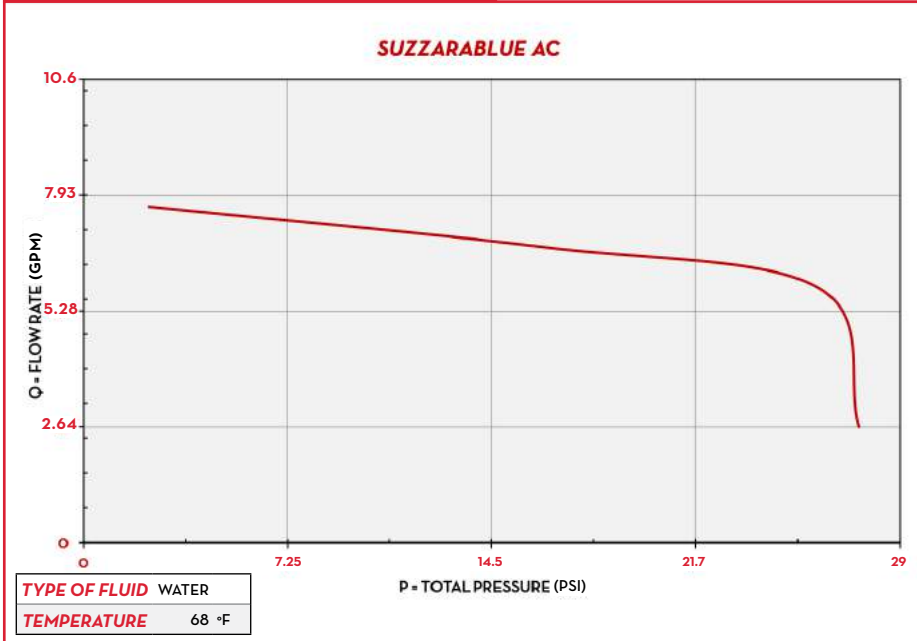

VARIOUS COMPONENTS

- BLUE BOX (R1611800A)
- SB PRO KIT (PAGE 20)
- MOUNTING PLATE (F20300000)
- PEDESTAL (OPTIONAL) (F1270800)

DETAILS



K24



AUTOMATIC NOZZLE



FOOT VALVE

DIMENSIONS

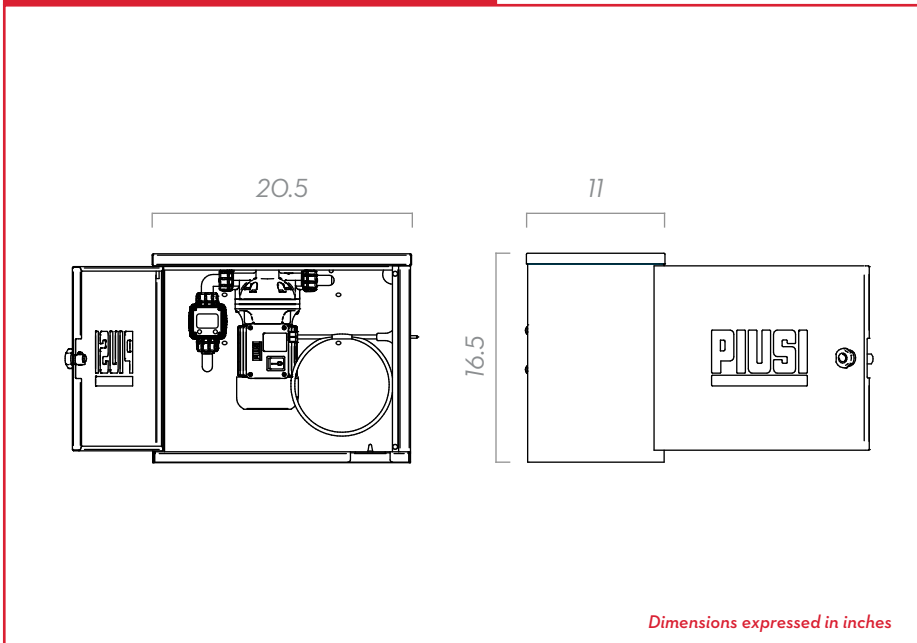

MATERIALS

- **PUMP:**
SUZZARBLUE PUMP AC PG. 28
- **METER:**
K24 METER PG. 46
- **NOZZLE:**
SUZZARBLUE A60 PG. 64

TECHNICAL DATA

PART #	DESCRIPTION	FLUIDS TYPE	FLOW RATE		VOLTAGE			METER	NOZZLE	HOSE LENGTH
			L/MIN	GPM	AC V/ HZ	POWER WATT	AMP. MAX.	MOD.	TYPE	
DEFPEDESTAL	DEF BLUE BOX PEDESTAL TANK KIT		34	9	120/60	400	1.95	K24	SUZZARBLUE NOZZLE A60	20 FT
R1611800A	KIT COMPLETE BOX FOR SUZZARBLUE BOX	-	-	-	-	-	-	-	-	-

DEF BLUE BOX PEDESTAL

STATIONARY



DURADEF™ NOZZLE

For DEF/AdBlue®

The FLEX-ING™ brand DuraDEF™ nozzle features a specially encapsulated aluminium casting that makes it lightweight yet completely compatible with DEF (Diesel Exhaust Fluid)/AdBlue®. This nozzle provides the performance and construction specifications required for DEF/AdBlue® delivery with a lightweight, more user-friendly design.

HIGHLIGHTS

- High strength aluminium body and stainless steel spout.
- Protective vinyl scuff guard available in green, yellow, red, blue, black and light blue to match station branding.
- Available with or without hold-open clip.
- Internal components are manufactured from stainless steel or plastic for full DEF/AdBlue® compatibility.
- Sealed in a plastic bag to ensure no contamination.
- Meets all required specifications set by ISO 22241 for DEF/AdBlue® delivery.

SPECIFICATIONS

- Inlet: ¾" BSPP
- Spout: 19mm stainless steel
- Seals and poppet disc: Viton® A
- Packing: PTFE
- Weight / length / height: 2.5 Lbs. / 13.5" / 9"
- Body casting: Coated aluminium
- Handguard and vac cap: Nylon
- Lever: Electroless nickel plated steel & nylon
- Scuff guard: Vinyl
- Body cap: Coated zinc

ORDERING INFORMATION

FLDEF A B C D - E - F

- FLDEF = DEF/AdBlue® Hose
- B = Hose Diameter
 - 02 = ¾"
- C = Hose Length Feet
 - Use three-digit format
- D = Hose Length Inches
 - Use two-digit format
- E & F = End Fitting Options
 - 2N = ¾" NPT
 - 2P = ¾" BSPP
 - 3P = 1" BSPP

Model	Description
DURADEF-LB	Light Blue DuraDEF nozzle with locking clip
DURADEF-LB-O	Light Blue DuraDEF nozzle without locking clip



HOSE

For DEF/AdBlue®

FLEX-ING™ brand diesel exhaust fluid hose features a specially formulated low-extraction EPDM rubber tube making it completely compatible with DEF/AdBlue®. The flexible softwall construction provides superior handling for both standard and reel applications. Each curb hose length features dual anti-kink sleeves at each end to protect the hose from accelerated wear and kinking. The anti-kink sleeves are factory installed over the end fitting ferrule to ensure maximum wear protection.

HIGHLIGHTS

- Peroxide cured tube provides superior extraction levels and significantly reduces contamination.
- Premium polyester braided construction reduces volumetric expansion.
- Integrated static wire.
- All curb hoses over 2' in length are outfitted with factory installed anti-kink sleeves on both ends.
- BSPP outlets include a fluoroelastomer flat seal to ensure compression tightness.

SPECIFICATIONS

- Tube: Specially formulated low-extraction EPDM rubber, peroxide cured
- Reinforcement: Polyester braid
- Cover: Specially formulated EPDM
- Temperature: -40 °F to 257 °F (-40 °C to 125 °C)

Approvals

- Meets ISO 22241 standard ensuring desirable characteristics of AUS 32 (DEF) are met, such as quality, safety, reliability and contamination.

ORDERING INFORMATION

FLDEF A B C - D - E

- FLDEF = DEF/AdBlue® Hose
- A = Hose Diameter
 - 2 = 3/4"
- B = Hose Length Feet
 - Use three-digit format
- C = Hose Length Inches
 - Use two-digit format
- D & E = End Fitting Options
 - 2N = 3/4" NPT
 - 2P = 3/4" BSPP
 - 3P = 1" BSPP
 - 3PF = 1" BSPP Female Swivel

Example: FLDEF200906-2N-2N = Def/Adblue® hose, 3/4" diameter, 9 feet 6 inches length, 3/4" NPT fitting on both ends.





SWIVEL BREAK AWAY

For DEF/AdBlue®

FLEX-ING™ brand diesel exhaust fluid swivel break aways provide in-line protection for hanging hardware in the event of a drive off. These break aways feature a stainless steel body that makes them extremely durable and completely compatible with DEF/AdBlue®. The break away design ensures proper drive-off protection and allows for easy installation directly between the nozzle and hose. The integrated swivel action provides easy nozzle rotation during vehicle filling while also helping to reduce hose wear and kinking.

HIGHLIGHTS

- High strength stainless steel body with internal components that are completely compatible with DEF/AdBlue®.
- Break away valves separate with axial or up to 30° angular force.
- Fluid release limited to less than 10 ml upon break away valve separation.
- Atmospheric inner seal protects from corrosion.
- Integrated swivel action provides easy nozzle rotation during vehicle filling while also helping to reduce hose wear and kinking.
- Available with either ¾" NPT and ¾" BSPP nozzle outlet and standard 1" BSPP female inlet.
- BSPP nozzle outlet includes a fluoroelastomer flat seal to ensure compression tightness between the break away and the nozzle inlet.

SPECIFICATIONS

- Body: Stainless steel
- Separation force: Between 180 Lbs. and 340 Lbs. force (800 N and 1,500 N force)
- Temperature rating: -22 °F to 131 °F (-30 °C to 55 °C)
- Internal pressure: Factory tested to 76.8 PSI (5.3 bar)
- Electric conductivity: Factory tested to < 100k Ohm
- Nozzle flow rate compatibility: Up to 21 gpm (80 lpm)
- Working pressures compatibility: 0.5 bar up to 3.5 bar

ORDERING INFORMATION

Model	Description
OMNIDDEF1X34N	¾" NPT nozzle outlet, 1" BSPP female inlet DEF swivel break away
OMNIDDEF1X34P	¾" BSPP nozzle outlet, 1" BSPP female inlet DEF swivel break away
OMNIDDEF1PXM34	M34 (metric) nozzle outlet, 1" BSPP female inlet DEF swivel break away

6

Model 9095AA 3” Overfill Prevention Valve

NEW PRODUCT ANNOUNCEMENT

Application

The 9095AA series overfill prevention valve is designed to prevent the overfilling of liquid storage tanks by providing a positive shut-off during a pressurized fill.

Features and Details

- Installs on tank top by threading onto a 6” male NPT riser
- Direct fill adaptor has 3” male quick disconnect
- Remote adaptor has 3” female NPT inlet threads for piping to remote fill point
- Full flow until shut-off point
- 1.23” of float height adjustment
- Integral pressure relief
- Integral anti-siphon function
- Optional test mechanism
- Drop tube adaptor accepts 3” drop fill tubes (Morrison 419)

Materials of Construction

- Direct fill adaptor... passivated aluminum
- Remote adaptor... ductile iron, powder coated
- Body... passivated aluminum
- Shaft, linkage, and hardware... stainless steel
- Lower pipe... e-coated steel
- Drop tube adaptor... passivated aluminum

Operational Criteria

- Minimum 5 PSI flow requirements
- Maximum operating pressure is 100 PSI
- Maximum viscosity of 300 centistokes
- A tight fill connection is required for the valve to operate
- The estimated flow rate is 560 GPM at 10 PSI pressure drop (See flow curve)

Code Compliance

ULC-S661-10 listed, NFPA 30, 30A, UFC, IFC, PEI/ RP200, PEI/RP 600, and Florida DEP EQ-851. California EVR models available



NOTE

For use on clean liquids only.

Item numbers and flow curve on next page.



MORRISON BROS. CO.



Item Number	Size	Description	Weight (lbs)	List Price
9095AA0300 AV	3"	AST overfill prevention valve, aluminum body, with 3" male quick disconnect x 6" female threads	21	\$1,277.92
9095AA3300AVEVR	3"	AST overfill prevention valve, aluminum body with 3" female threaded x 6" Female threaded connections; CARB EVR approved	30	\$1,277.92
9095AA9300AVEVR	3"	AST overfill prevention valve, aluminum body, less top connection; CARB EVR approved	14.4	\$1,174.65
9095ATM0100 AM	2" & 3"	Mechanical test mechanism kit	1	\$114.31

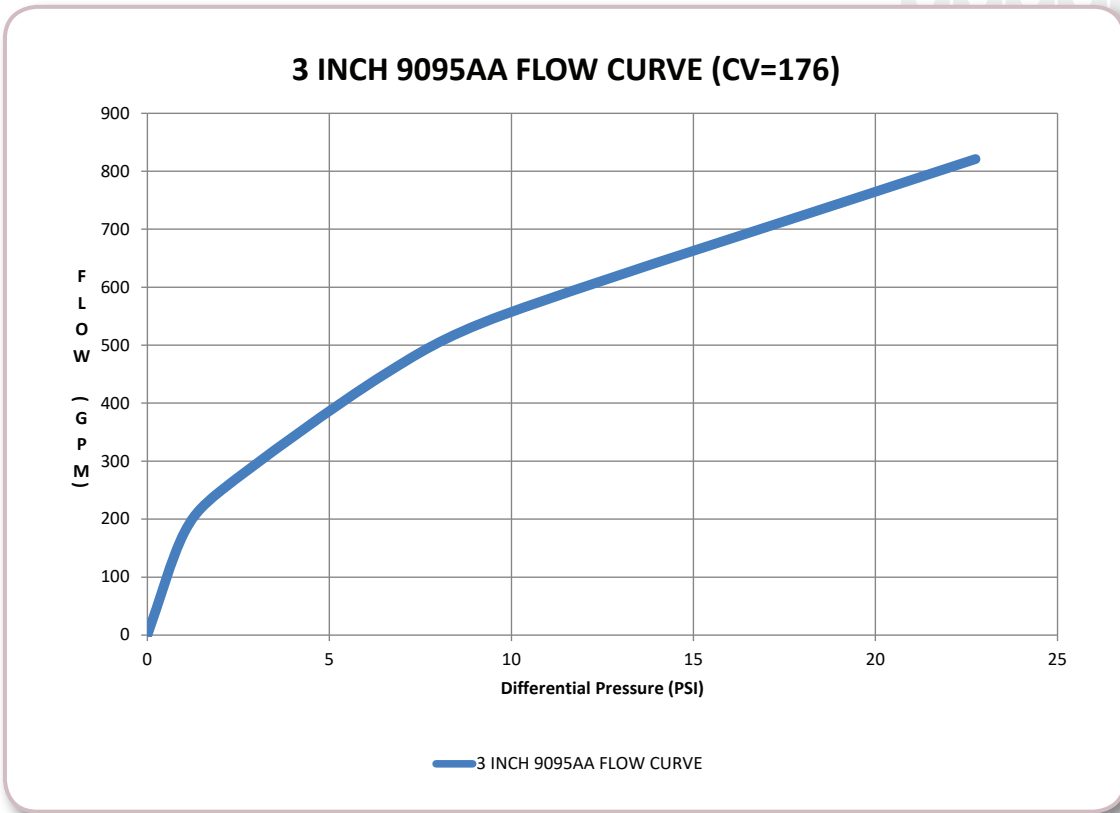



A0060 Shear Valve

**ATEX & UL
Approved***

- **Beefier Castings for Rugged Reliability**
- **Mounting Bolts Included**



**Stainless Steel Versions for E85,
DEF, Ultra Low Sulfur Diesel &
Biodiesel Blends up to B100**

EMCO WHEATON RETAIL CORPORATION

2300 Industrial Park Drive • Wilson, North Carolina 27893
252-243-0150 • 252-243-4603 (fax) • www.emcoretail.com

*ATEX approval on
cast iron variants



A0060

Emergency Shear Valve

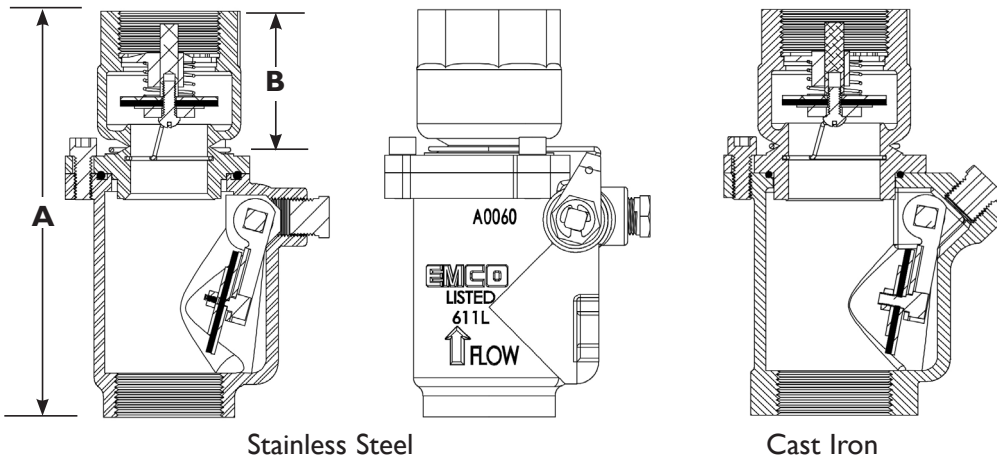

Stainless Steel

Cast Iron

Materials

Body: Cast Iron or Stainless Steel
 Spring: Stainless Steel
 Seal: Viton®

Viton® is a registered trademark of The Chemours Company

Approvals

UL MH6518 

ATEX FTZU14ATEX0204 
 (Cast iron variants)

Guide Specification: Emergency shut off valve for installation under gasoline dispensing units. Incorporates a replaceable shear section and a heat sensitive fusible link assembly. Valve can be manually operated to facilitate dispenser maintenance and incorporates a 3/8" test port. Closing poppet assembly is positioned out of the fuel flow path to minimize pressure drop. The A0060 utilizes a standard three boss mounting arrangement. Available in single poppet and double poppet configurations. Cast iron versions are powdered coated.

Model No. Cast Iron	Model No. Stainless Steel	Description	Inlet	Outlet	Cast Iron Lbs.	SST Lbs.	A	B
A0060-002	A0060-002S	1 1/2" Single Poppet	Female	Male	5.7	6.4	6.9"	2.2"
A0060-003	A0060-003S	1 1/2" Single Poppet	Female	Female	5.6	6.3	6.7"	1.7"
A0060-015	A0060-015S	1 1/2" Single Poppet	Female BSPT	Male BSPT	5.7	6.4	7.9"	3.2"
A0060-016	A0060-016S	1 1/2" Single Poppet	Female BSPT	Female BSPT	5.6	6.3	6.9"	2.2"
A0060-022	A0060-022S	1 1/2" Double Poppet	Female	Male	5.8	6.7	7.9"	3.2"
A0060-023	A0060-023S	1 1/2" Double Poppet	Female	Female	5.7	6.4	6.9"	2.2"
A0060-025	A0060-025S	1 1/2" Double Poppet	Female BSPT	Male BSPT	5.8	6.7	7.9"	3.2"
A0060-026	A0060-026S	1 1/2" Double Poppet	Female BSPT	Female BSPT	5.7	6.4	6.9"	2.2"

Replacement Parts

Part No. Cast Iron	For Use On	Part No. Stainless Steel	For Use on	Description	Outlet	Cast Iron Lbs.	SST Lbs.
492938	A0060-002	492938S	A0060-002S	1 1/2" Replacement Top; 1 Poppet	Male	2.2	2.5
492939	A0060-003	492939S	A0060-003S	1 1/2" Replacement Top; 1 Poppet	Female	2.3	2.6
493885	A0060-016	493885S	A0060-016S	1 1/2" Replacement Top; 1 Poppet	Female BSPT	1.4	1.6
493886	A0060-015	493886S	A0060-015S	1 1/2" Replacement Top; 1 Poppet	Male BSPT	1.6	1.8
493887	A0060-022	493887S	A0060-022S	1 1/2" Replacement Top; 2 Poppets	Male	2.7	3.0
493888	A0060-023	493888S	A0060-023S	1 1/2" Replacement Top; 2 Poppets	Female	2.7	3.0
493889	A0060-025	493889S	A0060-025S	1 1/2" Replacement Top; 2 Poppets	Male BSPT	1.6	1.8
493890	A0060-026	493890S	A0060-026S	1 1/2" Replacement Top; 2 Poppets	Female BSPT	1.6	1.8
492963K				Fusible Link Kit		0.2	
564036				Control Arm			
A0065-001				A0060 Stabilizer Bar Mounted Kit		3.8	

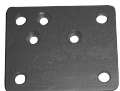

A0065
Mounting Kit

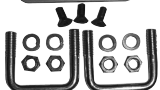

Emco Wheaton Retail Corporation

2300 Industrial Park Drive • Wilson, North Carolina 27893
 252-243-0150 • 252-243-4603 (fax) • www.emcoretail.com

Model 76DI & 78DI Expansion Relief Valves

SPECIFICATION SHEET

Application

Expansion Relief Valves are used on AST piping for relief of excess pressure caused by thermal expansion of liquid. The Valve allows product to return back to the storage tank.

076DI...Specify 25 or 50 PSI. Primarily for use with line leak detection systems. Use Fig. 76DI anytime you need to maintain precise pressures in the piping system.

078DI...Specify 25, 40 or 100 PSI. Pressure settings are approximate.

Materials of Construction

076DI

- Body... Ductile iron
- Cap... Stainless steel
- Relief fitting... Stainless steel with FKM

078DI

- Body... Ductile iron
- Cap... Stainless steel
- Spring... Stainless steel
- Ball... Stainless steel



Item Number	A	B	C	D	E	F	G	Weight
076DI-0100 AV	1/2"	25	DI	SS	SS/P	NA	NA	0.75
076DI-0200 AV	1/2"	50	DI	SS	SS/P	NA	NA	0.75
078DI-0100 AV	1/2"	25	DI	SS	NA	SS	SS	0.75
078DI-0200 AV	1/2"	40	DI	SS	NA	SS	SS	0.75
078DI-0300 AV	1/2"	100	DI	SS	NA	SS	SS	0.75

SPECIFICATION OPTIONS:

- A**—Size (inches)
- B**—PSI setting
- C**—Body material: DI (Ductile Iron)
- D**—Cap material: SS (Stainless Steel)
- E**—Expansion relief Valve Material: SS/TF (Stainless Steel/PTFE), NA (Not Applicable)
- F**—Spring material: SS (Stainless Steel), NA (Not Applicable)
- G**—Check ball material: SS (Stainless Steel), NA (Not Applicable)
- Weight**—Shipping weight (lbs)

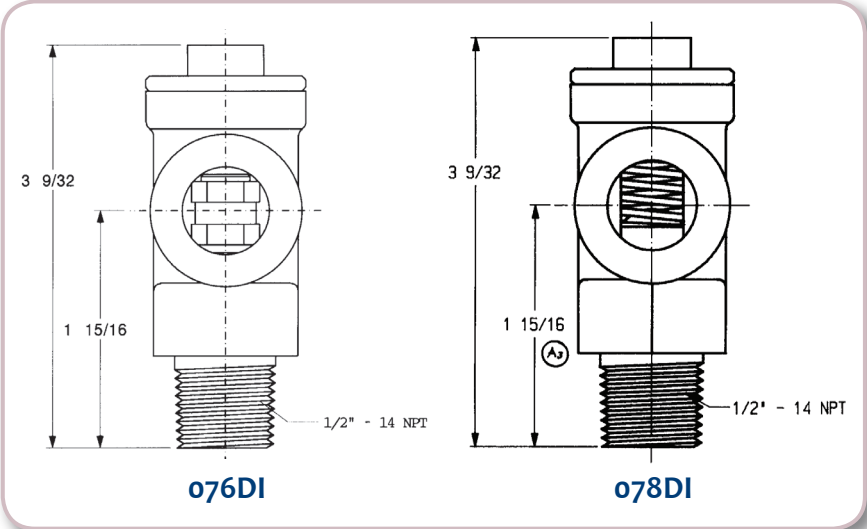

570 E. 7th Street, P.O. Box 238 | Dubuque, IA 52004-0238

t. 563.583.5701 | 800.553.4840 | f. 563.583.5028

www.morbros.com



Model 710 Solenoid Valve (Normally Closed)

SPECIFICATION SHEET

Application

Normally closed solenoid valves are used to help prevent the accidental siphoning of a product from a tank in the event of a leak downstream below the liquid level. They are generally installed on the dispensing side of a fuel system pipeline. The valve opens upon the receipt of an electronic signal such as when a dispenser or pump is switched to the 'on' position.

Features and Details

- Normally closed, hung piston design
- Operates at 120 volts AC (24, 208, 220, 240, & 480 volts AC, and 12, 24, and 48 volts DC also available)
- Minimum operating temperature is -40°F
- Includes a continuous duty Class H standard coil. Other options are available
- Install in a horizontal pipeline in the upright vertical position
- Zero pressure differential
- Integral thermal relief allows the valve to relieve expansion pressure in the opposite direction of flow
- Enclosure is watertight and rated for hazardous locations—NEMA 3, 4X, 7 and 9; groups C and D
- Several optional coil voltages available
- Recommended for use with liquids having a maximum viscosity of 60 centistokes
- A strainer with a 100 mesh screen is recommended at the valve inlet
- **710** has a cast bronze body
- **710MO** has manual override feature. Available in sizes ranging from 3/4" to 2" for operation during a power outage
- **710SS** has a stainless steel body

Materials of Construction

- Solenoid housed in an integral, watertight, explosion-proof shell

Certifications and Listings

CSA listed (File No. 108921, Model Z1314); Class I, Groups C and D; Class II, Groups E, F and G; Class III; T3C

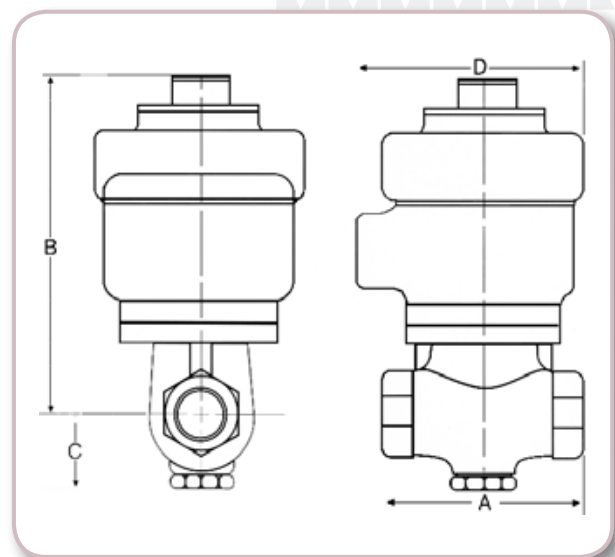

Item numbers, dimensions, and water flow vs. pressure drop chart on next page.





Item Number	Size (NPT)	Seal Material	Orifice Size (inches)	CV	Operating Pressure Differential Max. (P.S.I.)		Fluid Temp. (Max) (Deg. F.)	Power Consumption (Watt)	Ship Weight (lbs)	Gen. Dimensions (inches)			
					Min.	Max				A	B	C	D
710-0075 1V	¾"	FKM	¾"	7	0	105	302	30	11.0	4.0"	5.90"	1.5"	4.38"
710-0100 1V	1"	FKM	1"	12	0	105	302	30	13.0	4.8"	6.25"	1.75"	4.38"
710-0150 1V	1½"	FKM	1¼"	17	0	105	302	30	16.0	5.40"	6.90"	2.0"	4.38"
710-0200 1V	2"	FKM	1½"	27	0	105	302	30	21.0	5.90"	7.0"	2.25"	4.38"
710-0300 1V	3"	FKM	3"	94	0	45	302	48	44.0	8.80"	9.50"	4.50"	4.38"
710MO-0075 1V	¾"	FKM	¾"	7	0	105	302	30	12.0	4.0"	5.90"	1.50"	4.38"
710MO-0100 1V	1"	FKM	1"	12	0	105	302	30	14.0	4.80"	6.25"	1.75"	4.38"
710MO-0150 1V	1½"	FKM	1¼"	17	0	105	302	30	17.0	5.40"	6.90"	2.00"	4.38"
710MO-0200 1V	2"	FKM	1½"	27	0	105	302	30	22.0	5.90"	7.0"	2.25"	4.38"
710SS-2075 1V	¾"	PTFE	¾"	7	0	105	356	30	13.0	4"	5.90"	1.50"	4.38"
710SS-2100 1V	1"	PTFE	1"	12	0	105	356	30	15.0	4.80"	6.25"	1.75"	4.38"
710SS-2150 1V	1½"	PTFE	1¼"	17	0	105	356	30	16.0	5.40"	6.90"	2.0"	4.38"
710SS-2200 1V	2"	PTFE	1½"	26	0	105	356	30	21.0	5.90"	7.0"	2.25"	4.38"
710SS-3300 1V	3"	PTFE	3"	93.60	0	45	356	48	44.0	8.80"	9.50"	4.50"	4.38"
710SS-0300 1V	3"	PTFE	3"	93.60	0	45	302	48	44.0	8.80"	9.50"	4.50"	4.38"

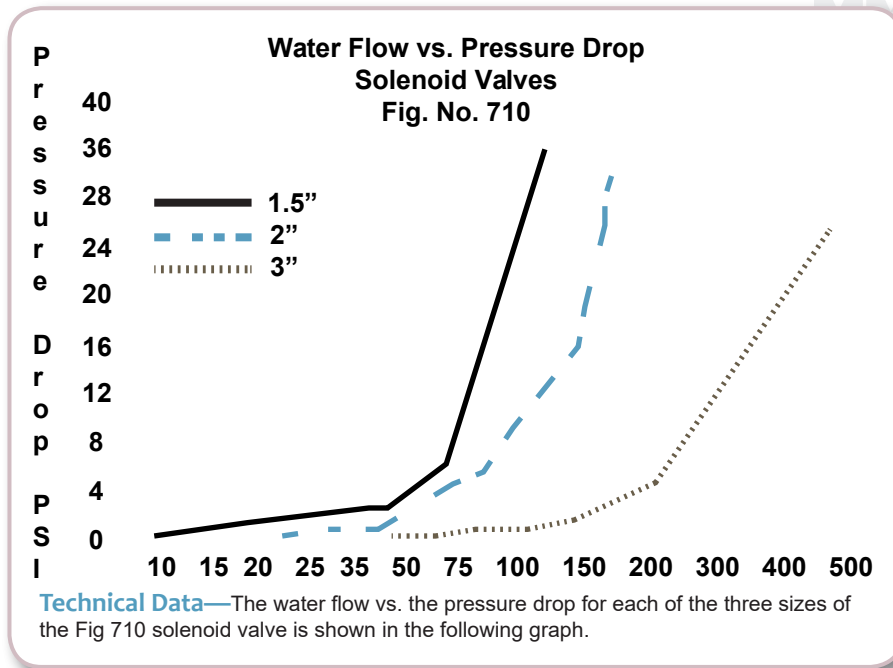

Model 749 Pressure Vacuum Vents

SPECIFICATION SHEET

Application

Pressure vacuum vents are installed on the top of underground and low volume aboveground storage tank vent pipes. Vent allows tank to “breathe” during filling and discharging operations. Pressure and vacuum poppets seal vapors in tank when pressure is equalized. Settings are approximate.

The 749T provides the same functions as the 749 and is designed for use on underground and low volume aboveground tanks storing Diesel Exhaust Fluid (DEF) and other products requiring PTFE and stainless construction.

Features and Details

- Screen protects the tank from debris and insects
- Integrated internal drain port channels water away from the tank
- Vent vapors up and outward per NFPA 30
- Conserves fuel
- Certified SCFH ratings

Materials of Construction

- Body and hood... anodized aluminum (**749T**—is PTFE coated aluminum)
- Pressure poppet... anodized aluminum (**749T**—is HDPE)
- Vacuum poppet... brass vacuum (**749T**—is stainless steel)
- Body seal... Buna-N (**749T**—is FKM)
- Screen... 40 mesh stainless steel
- Springs... stainless steel
- Set screws... Zinc-plated steel (**749T**—is Nylon)
*HDPE = High density polyethylene

Certifications and Listings

CARB 95-14 (749CRB0500 model); CARB 95-15 (749CRB0600 model); CARB 96-19 (749CRBS0600 model); 749CRB Pressure Vacuum Vents (models 749CRB0600 AV, 749CRB1600 AV, 749CRBS0600 AV and 749CRBS1600 AV), meet the requirements of EPA 40 CFR part 63 for Gasoline Dispensing Facilities



WARNING

Fig. 749 P/V vent must only be used in conjunction with motor fueling and/or low capacity flow. Fluid handling in lines larger than that used for retail service stations can cause tank to rupture or implode.

WARNING: DO NOT FILL OR UNLOAD FUEL FROM A STORAGE TANK UNLESS IT IS CERTAIN THAT THE TANK VENTS WILL OPERATE PROPERLY. Morrison tank vents are designed only for use on shop fabricated atmospheric tanks which have been built and tested in accordance with UL 142, NFPA 30 & 30A, and API 650 and in accordance with all applicable local, state, and federal laws. In normal operation, dust and debris can accumulate in vent openings and block air passages. Certain atmospheric conditions such as a sudden drop in temperature, below freezing temperatures, and freezing rain can cause moisture to enter the vent and freeze which can restrict internal movement of vent mechanisms and block air passages. All storage tank vent air passages must be completely free of restriction and all vent mechanisms must have free movement in order to insure proper operation. Any restriction of airflow can cause excessive pressure or vacuum to build up in the storage tank, which can result in structural damage to the tank, fuel spillage, property damage, fire, injury, and death. Monthly inspection, and immediate inspection during freezing conditions, by someone familiar with the proper operation of storage tank vents, is required to insure venting devices are functioning properly before filling or unloading a tank.



Item Number	A	B	C	D	E	SCFH	Height	Weight
749---0100 AV	2N	8.0 oz	0.50 oz	M	N	6200 @ 20oz./in.sq.	4.33	1.0
749---0200 AV	2N	12.0 oz	0.50 oz	M	N	7500 @ 25oz./in.sq.	4.33	1.0
749---1100 AV	3N	8.0 oz	0.50 oz	M	N	6200 @ 20oz./in.sq.	5.91	1.55
749---1200 AV	3N	12.0 oz	0.50 oz	M	N	7500 @ 25oz./in.sq.	5.91	1.55
749S--0100 AV	2S	8.0 oz	0.50 oz	M	N	6200 @ 20oz./in.sq.	4.33	1.0
749S--0200 AV	2S	12.0 oz	0.50 oz	M	N	7500 @ 25oz./in.sq.	4.33	1.0
749S--1100 AV	3S	8.0 oz	0.50 oz	M	N	6200 @ 20oz./in.sq.	6.28	1.65
749S--1200 AV	3S	12.0 oz	0.50 oz	M	N	7500 @ 25oz./in.sq.	6.28	1.65
749CRB0500 AV	2N	8.0 oz	5.0 oz	V	Y	6200 @ 20oz./in.sq.	4.33	1.45
749CRB0600 AV	2N	3" W.C.	8" W.C.	V	Y	3800 @ 8.2" H2O	4.33	1.95
749CRB1500 AV	3N	8.0 oz	5.0 oz	V	N	6200 @ 20oz./in.sq.	5.91	1.65
749CRB1600 AV	3N	3" W.C.	8" W.C.	V	N	3800 @ 8.2" H2O	5.91	1.65
749CRBS600 AV	2S	3" W.C.	8" W.C.	V	N	3800 @ 8.2" H2O	4.33	1.45
749CRBS1600 AV	3S	3" W.C.	8" W.C.	V	N	3800 @ 8.2" H2O	6.28	1.95
749BSP0100 AV	2B	8.0 oz	0.50 oz	M	N	6200 @ 20oz./in.sq.	4.33	1.0
749BSP0200 AV	2B	12.0 oz	0.50 oz	M	N	7500 @ 25oz./in.sq.	4.33	1.0
749T--0200 AV	2S	8.0 oz	0.50 oz	V	N	7500 @ 25oz./in.sq.	4.33	1.0

SPECIFICATION OPTIONS:

- A**— Body connection: 2" NPSM (2N), 2" Slip-on style (2S), 2" BSP (2B), 3" NPSM (3N), or 3" Slip-on style (3S)
- B**—Pressure setting: oz = oz/sq inch, wc = water column
- C**—Vacuum setting: oz = oz/sq inch, wc = water column
- D**—Pressure seal: metal-to-metal seat (M) or metal/FKM o-ring seat (V)
- E**—C.A.R.B. approval: yes or no (Y/N)
- Height**—Dimension from base to top of vent
- Weight**—Shipping weight (lbs)



Model 354 Updraft Vent

SPECIFICATION SHEET

Application

Atmospheric updraft vents are installed on the top of storage tank vent pipes on underground and aboveground fuel storage tanks.

Features and Details

- Directs vapors outward and upward in accordance with NFPA 30
- Protects the vent line from debris and insects
- Water-resistant rain cap sheds water away from the vent line
- Slip-on design with set screws for easy installation
- Internal drain channels water penetration out through weep hole
- **354T** is compatible with DEF

Materials of Construction

354

- Body and cap... aluminum die cast
- Screen... 40 mesh stainless steel

354T

- Body and cap... PTFE coated black aluminum
- Screen... 40 mesh stainless steel

Certifications and Listings

- CARB 89-12 (1½" and 2" 354 models)

Item Number	Size (slip-on)	Weight (lbs)	Venting Capacity (SCFH) (@ 2.5 PSI)
354--0100 AV	1½"	0.75	27,650
354--0200 AV	2"	0.75	27,650
354--0300 AV	3"	1.50	59,000
354--0400 AV	4"	2.25	116,900
354T--0200 AV	2"	0.75	27,650
354T--0300 AV	3"	1.50	59,000



354 (2")



354T (2")

NOTE

Open vents will allow unrestricted evaporation of product.

WARNING: DO NOT FILL OR UNLOAD FUEL FROM A STORAGE TANK UNLESS IT IS CERTAIN THAT THE TANK VENTS WILL OPERATE PROPERLY.

Morrison tank vents are designed only for use on shop fabricated atmospheric tanks which have been built and tested in accordance with UL 142, NFPA 30 & 30A, and API 650 and in accordance with all applicable local, state and federal laws. In normal operation, dust and debris can accumulate in vent openings and block air passages. Certain atmospheric conditions such as a sudden drop in temperature, below freezing temperatures, and freezing rain can cause moisture to enter the vent and freeze which can restrict internal movement of vent mechanisms and block air passages. All storage tank vent air passages must be completely free of restriction and all vent mechanisms must have free movement in order to insure proper operation. Any restriction of airflow can cause excessive pressure or vacuum to build up in the storage tank, which can result in structural damage to the tank, fuel spillage, property damage, fire, injury, and death. Monthly inspection, and immediate inspection during freezing conditions, by someone familiar with the proper operation of storage tank vents, is required to insure venting devices are functioning properly before filling or unloading a tank. Normal vents such as pressure vacuum and updraft vents for aboveground storage tanks should be sized according to NFPA 30 (2008) 21.4.3

570 E. 7th Street, P.O. Box 238 | Dubuque, IA 52004-0238

t. 563.583.5701 | 800.553.4840 | f. 563.583.5028

www.morbros.com



1519 Mechanical Tank Top Gauge with Relay Output

SPECIFICATION SHEET

Application

Designed for installation on top of horizontal and vertical tanks up to 25' in height, the 1519 mechanical tank gauge provides a readout in feet and inches and includes a single liquid level set point to activate an external alarm box.

Features and Details

- Viewable up to 25' in tank height
- Readout in feet and inches
- Easy to read from wide viewing angle
- Easy to install and calibrate
- Installs through 2" schedule 40 pipe or 2" tank bung (drop tube float models require a 4" tank opening)
- Vapor tight to allow for standard tank pressure testing and sealing up to 5 PSI
- Vapor is contained from viewing area to prevent lens fogging
- **1519M**...metric versions available to mount on top of horizontal and vertical tanks up to 7 meters (23') in height, providing readouts in centimeters

Gauge with Relay Output

- Desired alarm level is set within gauge head
- Alarm level setting can be verified
- The level alarm relay output wiring from the gauge has to be connected to an external alarm box (*sold separately*). Options include the 918 series and 918AC series alarm boxes.

Battery Power Module

- Can be installed in any convenient location
- One 3.6 volt lithium AA replaceable battery
- Anticipated battery life is 4 years
- Low battery light indicator

Alpha Wire 77112 (required cable for connecting gauge to Battery Power Module)*

- 5 Conductors
- 22 AWG (7/30 Stranded) tinned copper
- Foil shield with drain wire
- Temperature range: -50 to 150C

*Wire needs to be purchased to connect a 1519 gauge to the Battery Power Module.

Separate wire is required from the gauge to external alarm. See external alarm specifications for wire requirements.



Materials of Construction, Code Compliance, and part numbers on next page.





Materials of Construction

- Body... Cast aluminum
- Gears and gear cogs... Acetal
- Hardware (including captive screws on front cover)... Stainless steel
- Float... Stainless steel
- Cable... Stainless steel
- Spring... 301 stainless steel
- Shaft bushing... Stainless steel
- O-ring... FKM
- Lens cover... Acrylic
- Power module enclosure... Polyester fiberglass

Code Compliance

UL/cUL 913

Item Number	Description	Float	Length
1519--2500 AG	Mechanical tank top gauge with alarm relay, angled face	Standard	0-25'
1519--2550 AG	Mechanical tank top gauge with alarm relay, vertical face	Standard	0-25'
1519--2510 AG	Mechanical tank top gauge with alarm relay, angled face	Drop Tube	0-25'
1519--2515 AG	Mechanical tank top gauge with alarm relay output, vertical face	Drop Tube	0-25'
1519M-7000 AG	Metric mechanical tank top gauge with alarm relay, angled face	Standard	0-700 CM
1519M-7050 AG	Metric mechanical tank top gauge with alarm relay, vertical face	Standard	0-700 CM
1519M-7010 AG	Metric mechanical tank top gauge with alarm relay, angled face	Drop Tube	0-700 CM
1519M-7015 AG	Metric mechanical tank top gauge with alarm relay, vertical face	Drop Tube	0-700 CM

Alpha Wire 77112 (required cable)

Item Number	Description	Length
1519--0015 CC	Five-conductor shielded cable	15'
1519--0025 CC	Five-conductor shielded cable	25'
1519--0050 CC	Five-conductor shielded cable	50' (spool)
1519--0100 CC	Five-conductor shielded cable	100' (spool)
1519--0200 CC	Five-conductor shielded cable	200' (spool)



7



The Morrison 715 Series remote fill box is a simple 10-gallon capacity cabinet that provides containment of small spills during tank filling operations. Each unit is supplied with tank mount brackets for easy installation on storage tanks.

Features

- 10-gallon (37.85 liter) capacity
- 2" or 3" male NPT threaded or 150# raised face flange top connection
- Vented and weatherproof
- Hinged door is lockable with a padlock
- Bottom sloped (right to left) toward drain and pump mounting location; drains on left side
- Vapor recovery mounting bracket integrated into the cabinet exterior
- Vapor recovery adaptor, cap, and u-bolt kits are available
- Available with hand pump assembly, ball valve, quick disconnect check valve coupler/adaptor, dry disconnect adaptor, and dust cap/plug in 2" or 3" configuration
- All connection assemblies are factory installed and tested prior to shipping
- DEF, Aviation, and E-85 models are available
- Post mount kits and four-leg stands are available in powder coated steel
- Four-leg stands are also available in stainless steel

Construction Details

- Box and door are 14-gauge steel, powder coated white, or 304 stainless steel
- Ball valve is Morrison 691 series brass or 691BSS series stainless steel
- Quick disconnect coupler and plug are aluminum, anodized aluminum, or stainless steel
- Quick disconnect adaptor and cap are anodized aluminum
- Dry disconnect adaptor and cap are aluminum, anodized aluminum, or stainless steel

Vapor recovery kit

- Vapor recovery adaptor is aluminum with FKM
- Vapor recovery cap is aluminum, powder coated orange
- Hand pump is steel construction, PTFE seals with FKM o-rings, or stainless steel with PTFE and FKM

Box dimensions

- Width = 24.38" Height = 28.88" (34.8" including flange) Depth = 19.19"

Approvals

CAN-ULC-S663-11; Florida DEP EQ-787



Fig. 715



Fig. 715S



Fig. 715
(flanged top connection)





Model 715 & 715S Remote Fill Box -Top Connection (continued)

SPECIFICATION SHEET

Item Number	Size	Description	Weight
715--T00-0000-0	3"—10 gal.	Top connection w/ no outlets	101 lbs
715-TT3-0000-0	3"—10 gal.	Top connection w/ no internal components	135 lbs
715--TT3-000B-0	3"—10 gal.	Top connection w/ hand pump	
715--TT3-2QBB-0	3"—10 gal.	Top connection w/2" AL female QD coupler, BR ball valve, hand pump	141 lbs
715-TT3-2MBB-0	3"—10 gal.	Top connection w/2" AL male QD adaptor, BR ball valve, hand pump	141 lbs
715--TT3-3QBB-0	3"—10 gal.	Top connection w/3" AL female QD coupler, BR ball valve, hand pump	144 lbs
715--TT3-3MBB-0	3"—10 gal.	Top connection w/3" AL male QD adaptor, BR ball valve, hand pump	144 lbs
715--TT3-2DBB-0	3"—10 gal.	Top connection w/2" AL dry disc adaptor, BR ball valve, hand pump	143 lbs
715--TT3-3DBB-0	3"—10 gal.	Top connection w/3" AL dry disc adaptor, BR ball valve, hand pump	158 lbs
715--TT3-2MB0-0	3"—10 gal.	Top connection w/2" AL male QD adaptor, BR ball valve	
715--TT3-3MB0-0	3"—10 gal.	Top connection w/3" AL male QD adaptor, BR ball valve	
715--TT3-2QB0-0	3"—10 gal.	Top connection w/2" AL female QD coupler, BR ball valve	
715--TT3-2DS0-0	3"—10 gal.	Top connection w/2" AL dry disc adaptor, SS ball valve	
715--TT3-2DSE-0	3"—10 gal.	Top connection w/2" AL dry disc adaptor, SS ball valve, E85 hand pump	
715S-TT3-0000-0	3"—10 gal.	SS top connection w/ no internal components	135 lbs
715S-TT3-2QBB-0	3"—10 gal.	SS top connection w/2" AL female QD coupler, BR ball valve, hand pump	132 lbs
715S-TT3-2MBB-0	3"—10 gal.	SS top connection w/2" AL male QD adaptor, BR ball valve, hand pump	132 lbs
715S-TT3-3QBB-0	3"—10 gal.	SS top connection w/3" AL female QD coupler, BR ball valve, hand pump	144 lbs
715S-TT3-3MBB-0	3"—10 gal.	SS top connection w/3" AL male QD adaptor, BR ball valve, hand pump	144 lbs
715S-TT3-2DBB-0	3"—10 gal.	SS top connection w/2" AL dry disc adaptor, BR ball valve, hand pump	135 lbs
715S-TT3-3DBB-0	3"—10 gal.	SS top connection w/3" AL dry disc adaptor, BR ball valve, hand pump	148 lbs
715S-TT3-2DS0-0	3"—10 gal.	SS top connection w/2" AL dry disc adaptor, SS ball valve	
715S-TT3-3DS0-0	3"—10 gal.	SS top connection w/3" AL dry disc adaptor, SS ball valve	
715S-TT3-2DSE-0	3"—10 gal.	SS top connection w/2" AL dry disc adaptor, SS ball valve, E85 hand pump	
715S-TT3-2MBE-0	3"—10 gal.	SS top connection w/2" AL male QD adaptor, BR ball valve, E85 hand pump	
715S-TT3-3DSE-0	3"—10 gal.	SS top connection w/3" AL dry disc adaptor, SS ball valve, E85 hand pump	
715S-TT3-2ES0-0	3"—10 gal.	SS top connection w/2" SS dry disc adaptor, SS ball valve	
715S-TT3-2ESS-0	3"—10 gal.	SS top connection w/2" SS dry disc adaptor, SS ball valve, SS hand pump	
715S-TT3-2SS0-0	3"—10 gal.	SS top connection w/2" SS female QD coupler, SS ball valve	
715S-TT3-2SSS-0	3"—10 gal.	SS top connection w/2" SS female QD coupler, SS ball valve, SS hand pump	
715S-TT3-3SS0-0	3"—10 gal.	SS top connection w/3" SS female QD coupler, SS ball valve	
715S-TT3-3SSE-0	3"—10 gal.	SS top connection w/3" SS female QD coupler, SS ball valve, E85 hand pump	
715--TF4-0000-0	2"—10 gal.	Flanged top connection w/ no outlets	
715S-TF4-0000-0	2"—10 gal.	SS flanged top connection w/ no outlets	
715--TF5-0000-0	3"—10 gal.	Flanged top connection w/ no outlets	
715S-TF5-0000-0	3"—10 gal.	SS flanged top connection w/ no outlets	
715---VR30 AK		3" Vapor recovery kit	
715---VR40 AK		4" Vapor recovery kit	
715---P060 AK		Post mount kit - 3" x 60" post with clamps and base	
715---S400 AS		Four-leg stand for 715 fill box, powder coated steel	
715S--S400 AS		Four-leg stand for 715 fill box, stainless steel	
715---0373 AK		Mounting plate assembly kit	

*Please consult Price List for additional options.

570 E. 7th Street, P.O. Box 238 | Dubuque, IA 52004-0238

t. 563.583.5701 | 800.553.4840 | f. 563.583.5028

www.morbros.com



MORRISON BROS. CO.

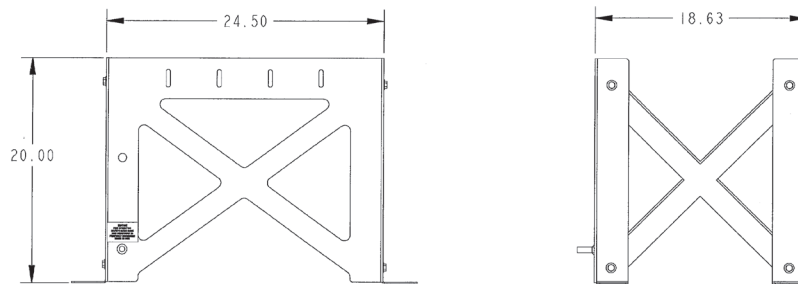
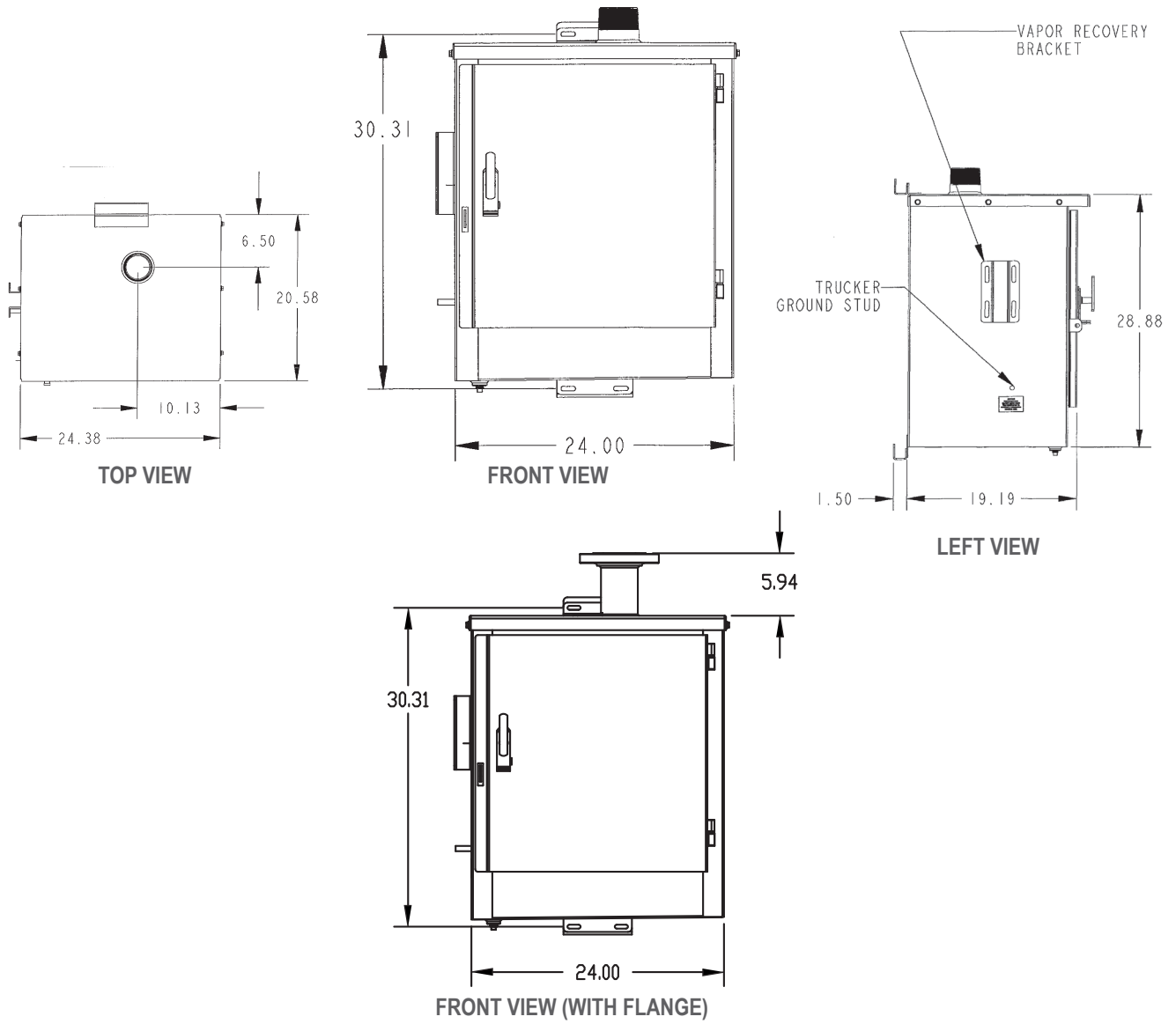

FOUR-LEG STAND



715 Part Numbering System

How to “Build-a-Box”

To order, simply select desired option from each category and insert the corresponding letter or number in the appropriate space below.

Example:

715 - - **T T 3** - **2 Q B B** - **0**

Model Number	715	-	-	T	T	3	-	2	Q	B	B	-	0	Open 0 Box only
Fill Box Construction	-													
	S													
	F													
	FS													
Mounting Style	T													
Outlet Location	0													
	B													
	F													
	K													
	T													
Outlet Fitting	0													
	2													
	3													
	4													
	5													
Component Size	0													
	2													
	3													
Hand Pump Assembly	0													
	B													
Ball Valve	0													
	B													
	S													
Inlet Connection	0													
	D													
	E													
	Q													
	S													
	M													

Additional Options:

- 60" Post mount kit: 715---P060 AK
- Mounting Plate: 715---0373 2PPW (not compatible with in-wall models)
- Stand: 715---S400 AS (4-leg stand, powder coated steel)
- Stand: 715S--S400 AS (4-leg stand, stainless steel)
- Vapor recovery kits: 715---VR30 AK (3") and 715---VR40 AK (4")



For a complete listing of 715 item numbers, please refer to the Morrison Price List.

570 E. 7th Street, P.O. Box 238 | Dubuque, IA 52004-0238

t. 563.583.5701 | 800.553.4840 | f. 563.583.5028

www.morbros.com

Model 73590CA Check Valve Adaptor

SPECIFICATION SHEET

Application

The 73590CA cam and groove adaptor with check valve is used in specialized applications where it is necessary and/or convenient to be able to connect and disconnect tank filling components quickly and cleanly.

Features and Details

- Male quick connect adaptor mates with traditional quick disconnect fill couplers
- Integrated check valve and fill adaptor reduces product loss at disconnect
- Space saving 90° design saving design fits into small spaces such as Morrison model 715 remote fill boxes

Materials of Construction

- Hard coated aluminum body
- Stainless steel plunger
- Viton® disc



Item Number	Size	Description	Weight (lbs)
73590CA0200 AV	2"	90° check valve; male adaptor; female threads	2.0
73590CA0300 AV	3"	90° check valve; male adaptor; female threads	5.0

Optional dust caps:

Item Number	Size	Description
735DCA2000ACEVR	2"	Anodized aluminum dust cap; EVR approved
735DCA3000ACEVR	3"	Anodized aluminum dust cap; EVR approved



570 E. 7th Street, P.O. Box 238 | Dubuque, IA 52004-0238

t. 563.583.5701 | 800.553.4840 | f. 563.583.5028

www.morbros.com

Model 927/928/735DC Series

SPECIFICATION SHEET

Application

The Morrison 927 dry disconnect adaptor is installed at the fill point in the fill line of a fuel storage tank system. The internal spring loaded poppet assembly remains closed providing a liquid-tight seal when not connected to a dry disconnect coupler.

The Morrison 928 dry disconnect coupler is installed on the end of delivery vehicle hose. When coupled, the 927 and 928 provide a liquid-tight connection enabling a dry connection and a dry disconnection.

The 735DC dust cap serves as a protective cover for the 927 adaptor when not in use.

927 models mate with PT Maxi-Dry® and OPW Kamvalok® couplers.

Code Compliance

735DC models meet California EVR VR-402 and US Military CID A-A-59326D; some 927 and 928 models meet CARB Phase 1 EVR VR-402



927 (2")



928 (2")



735DC (4")

Item Number	Size	Description	A	B	C	D	E	Cap Size	Weight (lbs)
927---0150 1A	1½"	Dry disconnect adaptor	1N	2"	A	F	N	2"	1.63
927---0200AAEVR	2"	Dry disconnect adaptor	2N	2½"	A	F	Y	2½"	1.98
927---0300AAEVR	3"	Dry disconnect adaptor	3N	4"	A	F	Y	4"	3.50
927---0400AAEVR	4"	Dry disconnect adaptor	4N	4"	A	F	Y	4"	3.50
9095A5201AAEVR	4" x 2"	Dry disconnect adaptor	4N	2½"	A	F	Y	2½"	2.50
927B--0200 AA	2"	Dry disconnect adaptor	2N	2½"	B	F	N	2½"	3.05
927S--0150 1A	1½"	Dry disconnect adaptor	1N	2"	SS	F	N	2"	3.80
927S--0200 1A	2"	Dry disconnect adaptor	2N	2½"	SS	F	N	2½"	5.90
927S--0300 1A	3"	Dry disconnect adaptor	3N	4"	SS	F	N	4"	18.25
928---0150 1C	1½"	Dry disconnect coupler	1N	2"	A	F	N	N/A	4.40
928---0150ACEVR	1½"	Dry disconnect coupler	1N	2"	A	F	Y	N/A	4.40
928---0200 1C	2"	Dry disconnect coupler	2N	2½"	A	F	N	N/A	6.0
928---0200ACEVR	2"	Dry disconnect coupler	2N	2½"	A	F	Y	N/A	6.0
928---0300 1C	3"	Dry disconnect coupler	3N	4"	A	F	N	N/A	12.60
928---0300ACEVR	3"	Dry disconnect coupler	3N	4"	A	F	Y	N/A	12.60
928S--0150 1C	1½"	Dry disconnect coupler	1N	2"	SS	F	N	N/A	--
928S--0200 1C	2"	Dry disconnect coupler	2N	2½"	SS	F	N	N/A	--
928S--0300 1C	3"	Dry disconnect coupler	3N	4"	SS	F	N	N/A	--
735DC-2000ACEVR	2"	Dust cap, use w/ 1½" 927 adaptors	N/A	N/A	A	B	Y	N/A	1.0
735DCA2000ACEVR	2"	Dust cap, use w/ 1½" 927 adaptors	N/A	N/A	AA	B	Y	N/A	1.0
735DC-2500ACEVR	2½"	Dust cap, use w/ 2" 927 adaptors	N/A	N/A	A	B	Y	N/A	1.25
735DCA2500ACEVR	2½"	Dust cap, use w/ 2" 927 adaptors	N/A	N/A	AA	B	Y	N/A	1.25
735DC-3000ACEVR	3"	Dust cap, use w/ 3" adaptors	N/A	N/A	A	B	Y	N/A	1.50
735DCA3000ACEVR	3"	Dust cap, use w/ 3" adaptors	N/A	N/A	AA	B	Y	N/A	1.50
735DC-4000ACEVR	4"	Dust cap, use w/ 3" & 4" 927 adaptors	N/A	N/A	A	B	Y	N/A	2.50
735DCA4000ACEVR	4"	Dust cap, use w/ 3" & 4" 927 adaptors	N/A	N/A	AA	B	Y	N/A	2.50

SPECIFICATION OPTIONS:

- A**—Female threads: 1½" NPT (1N); 2" NPT (2N); 2" NPS (2S); 3" NPT (3N); 4" NPT (4N)
- B**—Coupler size
- C**—Body: Hard coated aluminum (A); Anodized aluminum (AA); Brass (B); Stainless steel (SS)
- D**—Seals: FKM (F); Buna-N (B)
- E**—EVR: Yes (Y); No (N)
- Cap size**—In inches
- Weight**—Shipping weight

570 E. 7th Street, P.O. Box 238 | Dubuque, IA 52004-0238
t. 563.583.5701 | 800.553.4840 | f. 563.583.5028

8

Southland

A MUELLER INDUSTRIES BRAND

- ▶ Southland is a leader in precision-made steel, red brass and malleable iron pipe, nipples, fittings and related products. Manufactured in our North American facilities and threaded to industry specifications to provide a secure and trusted fit, Southland products are the trusted choice for plumbing, OEM, oil, gas and steam applications. Durable and highly resistant to rust and corrosion, every Southland pipe, nipple and fitting is 100% inspected and quality tested.



Piping will be 1-1/2" piping and 3" black piping.

▶ Steel Pipe & Ready Cut Pipe

Our extensive line of welded black steel and galvanized steel pipe meets rigid industry standards – and is backed by one of the most trusted names in the industry. Available in 1/4" to 4" diameters and offered in various lengths including 10-foot or 21-foot cut lengths, our steel pipes offer a choice of plain, threaded or coupled ends.

Product Highlights:

- Available from 1/8" – 4" Diameters
- Available in Black & Galvanized
- Available in Ready Cut Pipe Assortments
- Pipes supplied in lengths from 10ft to 21ft
- Produced by Electric Resistance Welded (ERW) process
- Produced in a stretched-reduced mill to ensure full body normalized pipe
- Hot dip galvanizing process according to ASTM standards
- Galvanized Products meet California Lead Plumbing Law

Specifications:

- **Welded steel pipe schedule 40 (1/2" through 6") and 80 (1/2" to 2")** complies with:
 - Galvanized Pipe – ASTM A-53 standard
 - Black Pipe – ASTM A-53 and API 5L standards
 - Threads – ASME/ANSI B1.20.1 standard
- **Seamless steel pipe schedule 40, 80, 160 in diameters from 1/8" to 4"** complies with:
 - Black pipe – ASTM A-106 grade B
 - Threads – ASME/ANSI B1.20.1 standard
 - Welded Steel Ready Cut Pipe
 - Schedule 40 and 80 in sizes from 1/2" to 4"
 - Galvanized Steel – ASTM A-53
 - Black Steel – ASTM A-53 / API 5L



▶ Steel Nipples

We manufacture both black and galvanized welded steel nipples in 11 diameters from 1" to 4" – and in 14 different lengths ranging up to 12". Available individually or in pre-packaged assortments, we also offer a full selection of pre-cut welded steel pipes in the same diameters and lengths.

Product Highlights:

- Available from 1/8" – 4" Diameters
- Available in Lengths from 6" to 12"
- Available in Black & Galvanized Schedule 40 and 80 Pipe Nipples
- Available in Black & Galvanized Schedule 40, 80, 160 & XXHvy Seamless Nipples
- NAFTA approved
- We also have available Merchant Couplings, Chrome Plated Nipples, Stainless Steel Nipples & Conduit Nipples
- Color coded product labels
- Preferred industry pack quantities
- Galvanized Products meet California Lead Plumbing Law

Specifications:

- **Welded Steel Pipe Nipples**
Black and Galvanized Schedules 40 and 80 in sizes from 1/8" through 6"
 - ASTM A-733, ASME/ANSI B1.20.1 and ASTM A-53
- **Seamless Steel Pipe Nipples**
Schedule 40 and 80 in sizes from 1/8" to 4"
 - Black Steel – ASTM A-733, ASME/ANSI B1.20.1 and A-106 grade B



Fittings will 1-1/2" and 3" black steel fittings as needed.

► Malleable Iron Fittings

We offer one of the most extensive selections of black and galvanized malleable iron fittings in the industry. Available in 13 diameters from 1/8" to 6", every fitting is produced to exact specifications. All galvanized products are zinc-coated for water applications – and meet all low-lead requirements. In addition, all of our iron fittings undergo our rigorous testing and quality inspection.

Product Highlights:

- Stocked in most figures from 1/8" to 6"
- Available in Black finish for oil and gas fluid applications
- Available in Galvanized finish for water, air and steam installations
- Available for servicing 150 psi and 300 psi applications
- Hot dip galvanizing process according to ASTM A-153 standard
- Galvanized Products meet California Lead Plumbing Law

Specifications:

- Threaded ends meeting with ANSI/ASME B1.20.1 standard
- Material meeting with ASTM A-197 standard
- Dimensions meet the following:
 - Threaded Fittings – with ASME B16.3 standard
 - Unions – with ASME B16.39 standard
 - Bushing Reducer and Plugs – with ASME B16.14 standard

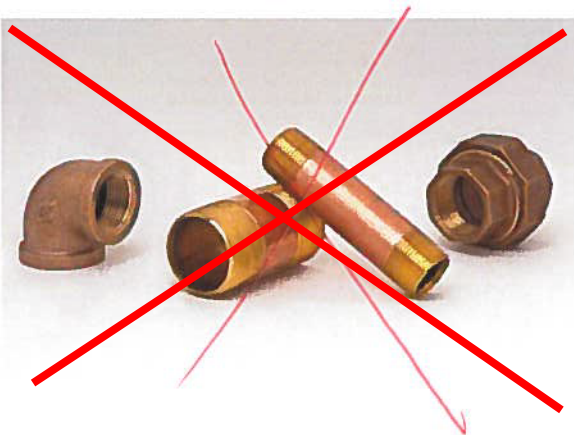

► Red Brass Fittings & Nipples

Our Red Brass Fittings and Nipples are carefully produced and threaded to industry specifications to provide a secure and trusted fit. While primarily developed for carrying water in commercial plumbing and OEM applications, they are also used in oil, gas and steam applications. Durable and highly resistant to rust and corrosion, every red brass fitting and nipple is 100% inspected and quality tested.

Product Highlights:

- Made with Class 125lb Red Brass
- Nipples Available in Lengths from Close to 12"
- Available in Schedule 40 diameters from 1/8" to 4"

Specifications:

- Red Brass Nipples meets ASTM B43-96 specifications
- All threads meet ASME/ANSI B1.20.1 standards
- Meets ASTM B-687 standards



FIREFLEX FLEXIBLE CONNECTORS

Since their introduction in 1995, FLEX-ING™ FIREFLEX Flexible Connectors have quickly become the industry standard and benchmark for quality as a means to easily connect one pipework system to other systems' components such as submersible pumps or shear valves. The benefit of their use is undeniable. They have quickly become an integral part of any installation. Installers love their ease of installation while station owners have come to depend on their durability and how easy they make regular maintenance. With tons of available options, Franklin Fueling Systems has the right connector to fit any application.

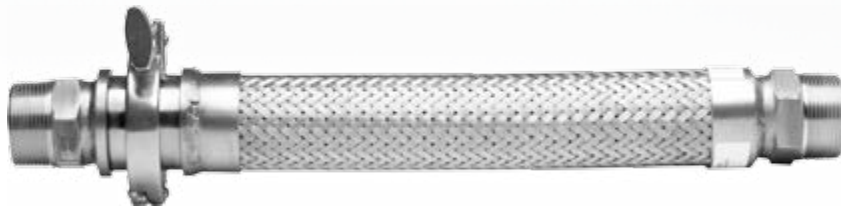

Highlights

- The corrugated fuel contact layers feature a 25% thicker metal construction and gain flexibility from having more corrugations per foot rather than thinner walls.
- Enclosing the corrugated fuel contact layer is a stainless steel braid that is manufactured from only high-grade stainless steel.
- Available in a multitude of end connections to ensure the right fit for any application - including tees, elbows, and FRP transitions
- The EZ FIT union style coupling system is specifically designed to make connections in confined spaces simple and tight.
- Each EZ FIT union style coupling comes complete with couplers and gaskets.

Specifications

- USA NFPA 30-A fire rated
- All metal construction means one flexible connector for both above and below ground applications
- An 18-8 alloy outer shell, 321 Stainless Steel inner core provides a long service life
- Thick, schedule 80 hex end fittings protect against deformation of the ends
- 100% pressure tested to assure quality
- UL 2039 approved for 50 psi working pressure
- EZ FIT clamp and gasket are included with each assembly

Approvals

- UL 2039 listed for above and below ground installation for use with gasoline, gas alcohol blends (up to E85), diesel, and biodiesel.

Ordering Information

Use these diagrams below along with the Ordering Guide at the bottom of the page to help you build your flexible connector model numbers.

Ordering Options Diagram

Use the options and descriptions in the Ordering Guide along with this diagram to assist in building your model numbers.

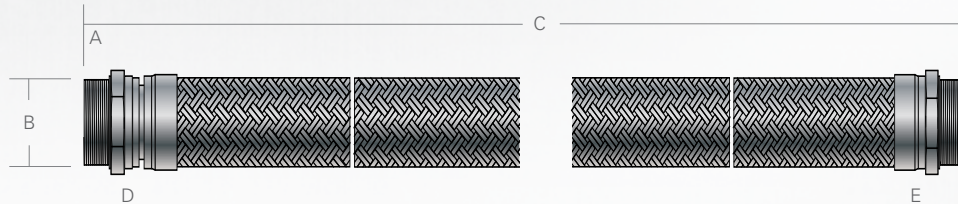

End Fitting Options

Use the options and descriptions in the Ordering Guide along with the diagrams below to select your end fitting types (two total).

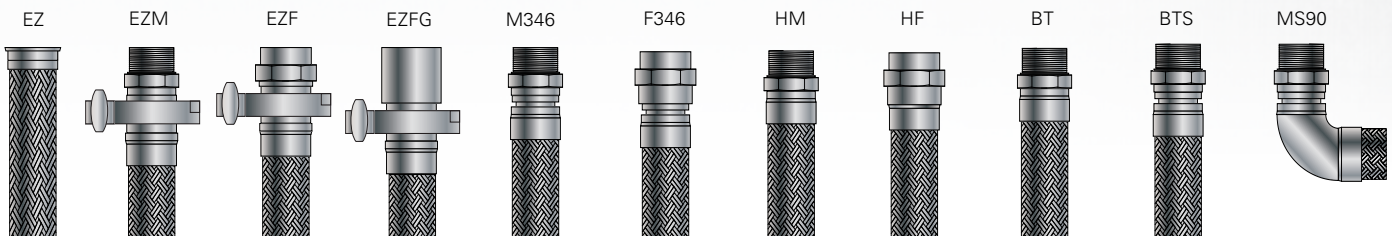

Ordering Guide

A B X C D X E

A = Product Type

FF = If either of the end connections are any type of swivel, this option must be selected.

FFUL = If both end connections are fixed (non-swivel), this option must be selected.

B = Hose Diameter

- 07 = 3/4"
- 10 = 1"
- 15 = 1 1/2"
- 20 = 2"
- 30 = 3"
- 40 = 4"

C = Overall Length in Inches

Use two-digit format

D & E = End Fitting Options

EZ = EZ FIT flange only

EZM = EZ FIT male NPT (Each EZ FIT union style coupling comes complete with couplers and gaskets)

EZF = EZ FIT female NPT (Each EZ FIT union style coupling comes complete with couplers and gaskets)

EZFG = EZ FIT fiberglass glue pipe (Each EZ FIT union style coupling comes complete with couplers and gaskets)

M346 = Male swivel NPT

F346 = Female swivel NPT

HM = Hex male fixed NPT

HF = Hex female fixed NPT

BT = Hex male fixed BSPT

BTS = Male swivel BSPT

MS90 = 90° with male swivel NPT

Example: FF20X18M346XHM = FIREFLEX flexible connector with swivel end fitting(s), 2" hose diameter, 18" overall length, with one male swivel end fitting and one fixed hex male end fitting.

Flexible Connectors with Differing Hose and End Fitting Diameters

All end fittings are, by default, the same diameter as the hose. If you require a flexible connector where the end fitting diameter does not match the hose diameter, the size must be indicated numerically in front of the corresponding fitting as in the following example.

Example : FFUL15X18HMX2HM = FIREFLEX flexible connector with fixed end fittings, 1 1/2" hose diameter, 18" overall length, with one 1 1/2" hex male fixed end fitting, and one 2" hex male fixed end fitting.

Rules:

- 1) End fitting diameters can not be smaller than hose diameters.
- 2) Only one hose fitting per flexible connector can be of a different diameter than the hose diameter.
- 3) End fitting diameter must only be one size larger than hose (1" hose could use 1 1/2" fitting, 1 1/2" hose could use 2" fitting, etc.)

9

MASTER YOUR

FUEL

MANAGEMENT

AUTOMATE YOUR FUELING PROCESS

FMU-2500 & 3505 SERIES

- *Built to military specifications*
- *Modular design and backward capability*
- *Ease of maintenance*
- *World class support*



 **FUELMASTER**
ENGINEERED BY syntech

MADE IN THE
USA

FMU-2500 & 3505 SERIES

CUSTOMIZE YOUR FUEL MANAGEMENT NEEDS

The FMU-2500Plus and FMU-3505Plus are the industry leaders in commercial fleet and retail fueling automation. The passive fueling automation of the 3505 Series compliments the interactive automation of the 2500 Series using our state of the art patented RFID 2.4 technology.

Note: All FMU-2500Plus units can be easily upgraded to include passive automated features found in the 3505 Series at the fuel island.

FEATURES & BENEFITS

- Handles up to 8 hoses
- Communicates with up to 8 satellite FMU, each handling 8 hoses, for a total of 72 hoses per master FMU
- Fueling process initiated by keypad; PROKEE®; smartcard; proximity card; or AIM module
- FMU can be equipped to read fleet, aviation, and standard credit cards. Contact us for a current list of available networks
- Works with mechanical and electronic dispensers, both retail and commercial
- Windows based software and operates on a SQL platform
- Transactional data can be exported to most fleet maintenance or accounting programs
- Communicates with a Tank Monitor Unit/Tank Gauge interface from a variety of manufacturers
- Supports Automatic/Manual Operation
- 24/7 Live customer support call center
- Customer Training provided at no cost
- All product research and development completed within our on-site Engineering Department



CONTACT US TO LEARN MORE

800.888.9136 850.878.2558

www.MyFuelMaster.com Marketing@MyFuelMaster.com

Syntech Systems, Inc. 100 Four Points Way, Tallahassee, FL 32305

10

Labeling Guidelines for:

NFPA 704 PLACARDS AND LABELS

The NFPA 704 Placard

The NFPA 704 Diamond ("NFPA Diamond" or "fire diamond") is a standard placard that identifies the level of chemical hazard at fixed locations, such as production facilities, warehouses, storage tanks, and storage sheds. It is required by the California Fire Code and meets requirements under the Hazard Communication Act ("Right to Know")

The NFPA 704 diamond (shown at right) is divided into four colored quadrants. Each quadrant provides information about the materials inside:

- **Blue** represents health hazard.
- **Red** represents flammability.
- **Yellow** represents reactivity.
- **White** provides information about special precautions.



Within each quadrant is a number from 0 to 4 indicating the degree of risk associated with the material. The higher the number, the higher the risk. For some materials, the white quadrant contains symbols indicating special hazards. (See NFPA Indicator Key, page 2)

Proper Hazard indicators (numbers) can be found on the product MSDS.

If more than one chemical is present at a facility, the NFPA diamond indicates overall hazard at that location, *not* the hazard posed by a particular chemical. It shows the highest of each of the four hazards present. For example, it may be that one chemical poses the highest health hazard while another poses the highest fire hazard.

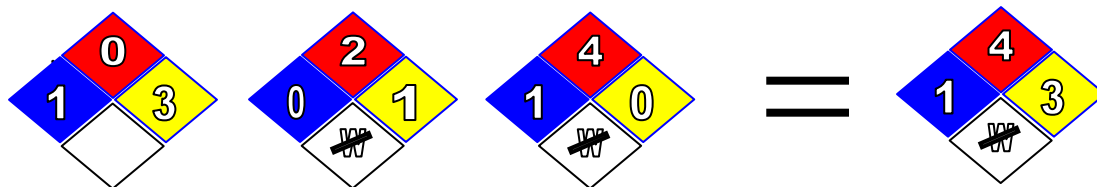

INSIDE BUILDING, CONTENTS

OUTSIDE PLACARD

Labels meeting NFPA 704 standards and the "Right to Know" can vary in format but consistently are the same in content.



RTK Label



HMIS Tag



NFPA Label

To meet Hazcom "Right to Know" act, labels must include:

- Manufacture
- Chemical name
- Common name
- Hazards

NFPA INDICATOR KEY

HEALTH HAZARD	FLAMMABILITY	REACTIVITY	SPECIAL
<p>4 - Materials which on very short exposure could cause death or major residual injury even through prompt medical treatment were given.</p>	<p>4 - Materials which will rapidly or completely vaporize at atmospheric pressure and normal ambient temperature, and which will burn.</p> <p>FLASH POINT < 73</p>	<p>4 - Materials which are readily capable of detonation or of explosive decomposition or reaction at normal temperatures and pressures.</p>	<p>Specific chemical hazards, special information and personal protective equipment will be noted in this section. Specific hazards and their symbols are as follows:</p>
<p>3 - Materials which on short exposure could cause serious temporary or residual injury even though prompt medical treatment were given.</p>	<p>3 - Liquids and solids that can be ignited under almost all ambient temperature conditions.</p> <p>FLASH POINT < 100</p>	<p>3 -Materials that can detonate or explode but require a strong initiating source, or must be heated under confinement before initiation, or react explosively with water.</p>	<p>OX- Oxidizer</p> <p>ACID - Acid</p> <p>ALK - Alkali</p> <p>COR- Corrosive</p> <p>-W- No Water</p> <p> Radioactive</p>
<p>2 -Materials which on intense exposure could cause possible residual injury unless prompt medical treatment is given.</p>	<p>2 -Materials that must be moderately heated or exposed to relatively high ambient temperatures before igniting.</p> <p>FLASH > 100 < 200</p>	<p>2 -Materials that are normally unstable and readily undergo violent chemical changes but do not detonate; also materials that may react violently with water.</p>	<p>HMIS</p> <p>A=Safety glasses B=Safety glasses, Gloves C=Glasses, gloves Protective apron D=Face shield, Gloves, apron E=Glasses, gloves Dust respirator F=glasses, gloves Respirator, apron G=Glasses, gloves Vapor respirator H=Goggles, gloves Apron, respirator I =glasses, gloves APR K=supplied air, Mask or hood Suit and boots Or symbols may be used</p>
<p>1 -Materials which on exposure would cause irritation but only minor residual injury even if no treatment is given.</p>	<p>1 -Materials that must be preheated before ignition can occur.</p> <p>FLASH POINT > 200</p>	<p>1 -Materials that are normally stable, but can become unstable at high temp. and pressures, or may react with water with some release of energy.</p>	
<p>0 -Materials which on exposure under fire conditions would offer no hazard beyond that of ordinary combustibles.</p>	<p>0 -Materials that will not burn.</p>	<p>0 -Materials that are normally stable even under fire explosive conditions, and that are not reactive with water.</p>	

11

Emergency Stop Solutions for Fueling Sites

Emergency Stop Controls are required by the National Electrical Code at ALL fueling facilities. Power Integrity offers a full line of emergency stop operators to meet your site requirements.



IA-ESOCA
Emergency Stop Operator
with Cover & Alarm

Emergency Stop Operators

- Available in momentary, twist-to-reset, key-to-reset, and break glass configurations
- Clear tamperproof cover protects against accidental activation, damage, and vandalism
- Optional alarm protects against nuisance activation
- Standard operator includes (1) NO and (1) NC contact
- Custom labeling available

Cashier Control Stations

- Allow employees to activate emergency stop system without leaving the cashier area
- Standard configuration includes
 - Emergency stop pushbutton
 - Emergency stop system reset pushbutton
- Available with optional lighting bypass switch
- Custom configurations available including
 - Product status lights
 - Timed lighting override
 - Individual dispenser shut-down



IA-ESORS
Cashier Control Station with
Protective Shroud



Power • Control • Protect



Power Integrity Corporation
1834 Pembroke Road
Greensboro, NC 27408
336.379.9773
www.powerintegritycorp.com

Typical Emergency Stop Installation

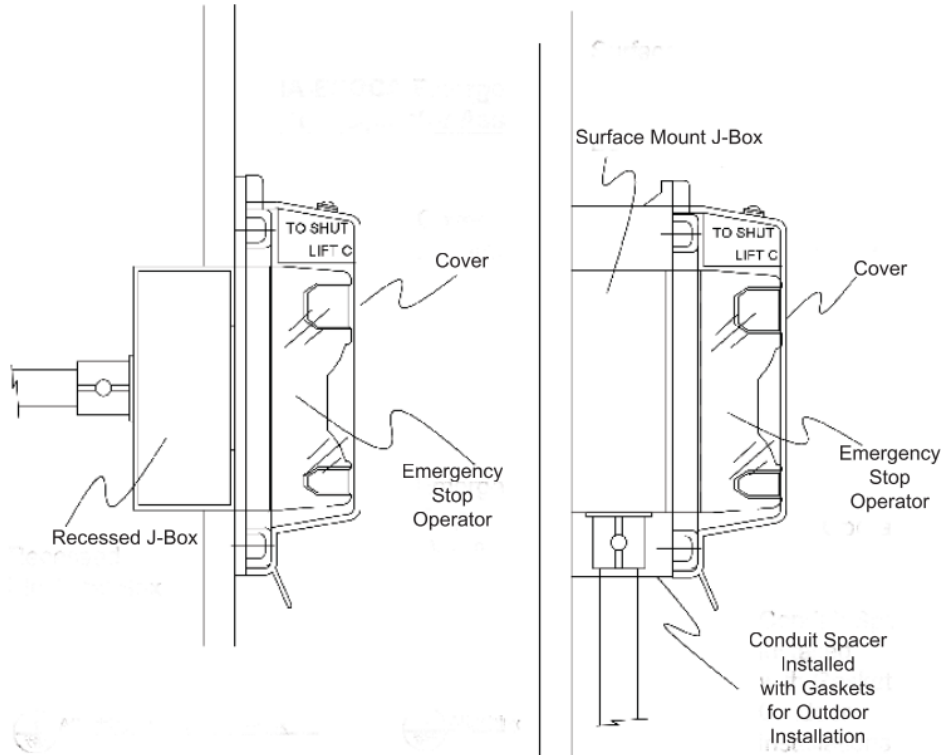

Attaching to Recessed Junction Box

Attaching to Surface Mount Junction Box

Emergency Stop Operators - Outdoor Rated	
IA-ESOC	Emergency stop operator with lift-up clear cover
IA-ESOCA	Emergency stop operator with lift-up clear cover and alarm
IA-ESOC/T	Emergency stop operator, twist to release with lift-up clear cover
IA-ESOCAT	Emergency stop operator, twist to release with lift-up clear cover and alarm
IA-ESOCK	Emergency stop operator, keyed reset with lift-up clear cover
IA-ESOG	Emergency stop operator with "Break Glass", hammer, and (5) replacement discs
Emergency Stop Operator Accessories	
IA-ESPLATE	Emergency stop operator mounting plate with "emergency fuel shutoff" nameplate
IA-BREAKTAB	Locking mechanism block with (5) one-time use breakaway seals
Cashier Control Stations - Indoor Rated	
IA-ESORS	Cashier control with emergency stop button with shroud to prevent accidental pressing, and reset button
IA-ESORLS	Cashier control with emergency stop button with shroud to prevent accidental pressing, reset button, and light control bypass switch
Emergency Stop Operator Lift-Up Covers	
IA-PBCOVSA	Small lift-up clear cover with alarm for e-stop operators, 5.5"W x 7.0"H (Yellow)
IA-PBCOVS	Small lift-up clear cover for e-stop operators, 5.5"W x 7.0"H (Yellow)
IA-PBCOVLAR	Large lift-up clear cover with alarm for e-stop operators 7.0"W x 9.0"H (Red)

www.powerintegritycorp.com



**Contributing Zone Plan Application
(TCEQ-10257)**

Attachment I:

**20% or Less Impervious Cover Declaration (if project is multi-family residential, a school, or a small business and 20% or less impervious cover is proposed for the site)
(NOT APPLICABLE)**



Contributing Zone Plan Application (TCEQ-10257)

Attachment J: BMPs for Upgradient Stormwater

Existing on-site sand filter basin Permanent BMP continues to address any upgradient stormwater. The proposed project does not increase the IC at the site.



Contributing Zone Plan Application (TCEQ-10257)

Attachment K: BMPs for On-Site Stormwater

The proposed project will not increase impervious cover (IC) and the volume of potential on-site stormwater. The existing and approved sand filter basin permanent BMP was designed to capture and will continue to mitigate potential onsite stormwater flows.

Runoff from the developed site and proposed fueling island will convey to the existing approved sand filter basin permanent BMP that is designed to capture and detain the required water quality volume. For additional information, see the original approved calculations.



**Contributing Zone Plan Application
(TCEQ-10257)**

**Attachment L:
BMPs for Surface Streams
(NOT APPLICABLE)**

No surface streams flow across the property.



PEC Liberty Hill
CONTRIBUTING ZONE PLAN MODIFICATION

Contributing Zone Plan Application (TCEQ-10257)

Attachment M: Construction Plans

PROJECT CONTACTS

OWNER: PEC
9115 CIRCLE DR.
AUSTIN, TX 78736

ENGINEER: SANDLIN SERVICES, LLC
9111 JOLLYVILLE RD, SUITE 212
AUSTIN, TEXAS 78759
806-679-7303
CONTACT: NICHOLAS SANDLIN, P.E.

CONTRACTOR: EXCELL FUELING SYSTEMS, INC
549 S LOOP 4
BUDA, TEXAS 78610
(512)280-5230

DATE OF SUBMITTAL: 3/20/24

APPROVALS:

SURVEY AND BENCHMARK

ALL ELEVATIONS SHOWN HEREON ARE BASED ON THE FOLLOWING BENCHMARKS AND INFORMATION.

CONTRACTOR TO PROVIDE FIELD SURVEY AND BENCHMARK

BEARINGS ARE BASED ON THE TEXAS STATE PLAN COORDINATE SYSTEM OF 1983, TEXAS CENTRAL ZONE (NAD 83)

LEGAL DESCRIPTION

S8162 – SEWARD JUNCTION COMMERCIAL PARK, LOT 2, ACRES 6.22

ZONING AND USE

JURISDICTION: LIBERTY HILL (FULL PURPOSE)
ZONING: C3 – GENERAL COMMERCIAL/RETAIL
EXISTING LAND USE: ELECTRIC SERVICE PROVIDER
PROPOSED LAND USE: UNCHANGED

WATERSHED

WATERSHED: SOUTH FORK SAN GABRIEL RIVER

EDWARDS AQUIFER

THIS PROJECT LIES WITHIN THE EDWARDS AQUIFER CONTRIBUTING ZONE AS DEFINED BY THE TEXAS COMMISSION ON ENVIRONMENTAL QUALITY (TCEQ)

FLOODPLAIN NOTE

THE 100-YEAR FLOODPLAIN AS DEFINED BY THE CITY REGULATION, IS CONTAINED WITHIN THE DRAINAGE EASEMENT(S) SHOWN HEREON, NO PORTION OF THIS TRACT IS WITHIN THE BOUNDARIES OF THE 100-YEAR FLOODPLAIN OF ANY WATERWAY THAT IS WITHIN THE LIMITS OF THE STUDY OF THE FEDERAL INSURANCE ADMINISTRATION FIRM PANEL #48491C0275E, AND INCORPORATED AREAS EFFECTIVE DATE 9/26/2008 FOR WILLIAMSON COUNTY, TEXAS.

REVISION RECORD

PEDERNALES ELECTRIC COOP CONTRIBUTING ZONE & ABOVE GROUND STORAGE TANK PLANS

ADDRESS: 10625 W STATE HWY 29, LIBERTY HILL, TX 76527

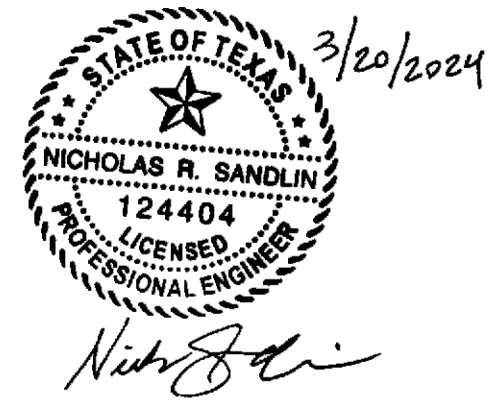

SHEET LIST	
NUMBER	TITLE
1	COVER PAGE
2	GENERAL NOTES (1 OF 4)
3	GENERAL NOTES (2 OF 4)
4	GENERAL NOTES (3 OF 4)
5	GENERAL NOTES (4 OF 4)
6	FINAL PLAT (1 OF 2)
7	FINAL PLAT (2 OF 2)
8	EROSION CONTROL AND DRAINAGE PLAN
9	AST TANK LAYOUT PLAN
10	EROSION CONTROL DETAILS

CONTRACTOR GENERAL NOTES

1. THE CONTRACTOR SHALL OBTAIN A "NOTICE OF PROPOSED INSTALLATION OF UTILITY LINE" PERMIT FROM THE COUNTY FOR ANY WORK PERFORMED IN THE EXISTING COUNTY RIGHT-OF-WAY (DRIVEWAY APRON, WATER MAIN TIE-IN, ETC.) THIS PERMIT APPLICATION WILL REQUIRE A LIABILITY AGREEMENT, A CONSTRUCTION COST ESTIMATE FOR WORK WITHIN THE RIGHT-OF-WAY INCLUDING PAVEMENT REPAIR (IF NEEDED), A PERFORMANCE BOND, CONSTRUCTION PLANS AND, IF NECESSARY, A TRAFFIC CONTROL PLAN. AN INSPECTION FEE, AND A PRE-CONSTRUCTION MEETING MAY ALSO BE REQUIRED, DEPENDING ON THE SCOPE OF WORK. THE PERMIT WILL BE REVIEWED AND APPROVED BY THE COUNTY ENGINEER, AND MUST ALSO BE APPROVED BY THE COUNTY COMMISSIONERS COURT IF ANY ROAD CLOSURE IS INVOLVED.
2. BY THE ACT OF SUBMITTING A BID FOR THIS PROPOSED CONTRACT, THE BIDDER WARRANTS THAT THE BIDDER, AND ALL SUBCONTRACTORS AND MATERIAL SUPPLIERS HE INTENDS TO USE, HAVE CAREFULLY AND THOROUGHLY REVIEWED THE DRAWINGS, SPECIFICATIONS AND ALL OTHER CONTRACT DOCUMENTS AND HAVE FOUND THEM COMPLETE AND FREE FROM ANY AMBIGUITIES AND SUFFICIENT FOR THE PURPOSE INTENDED. THE BIDDER FURTHER WARRANTS THAT TO THE BEST OF HIS OR HIS SUBCONTRACTORS' AND MATERIAL SUPPLIERS' KNOWLEDGE, ALL MATERIALS AND PRODUCTS SPECIFIED OR INDICATED HEREIN ARE ACCEPTABLE FOR ALL APPLICABLE CODES AND AUTHORITIES.
3. THE LOCATION OF ALL EXISTING UTILITIES SHOWN ON THESE PLANS HAS BEEN BASED UPON RECORD INFORMATION ONLY AND MAY NOT MATCH LOCATIONS AND/OR DEPTHS AS CONSTRUCTED. THE CONTRACTOR SHALL CONTACT THE AUSTIN AREA "ONE CALL" SYSTEM 1-800-245-4545, OR THE OWNER OF EACH INDIVIDUAL UTILITY, FOR ASSISTANCE IN DETERMINING EXISTING UTILITY LOCATIONS AND DEPTHS PRIOR TO BEGINNING ANY CONSTRUCTION. CONTRACTOR SHALL FIELD VERIFY LOCATIONS OF ALL UTILITY CROSSINGS PRIOR TO BEGINNING ANY CONSTRUCTION.
4. THE CONTRACTOR OR SURVEYOR WILL OBTAIN A DIGITAL COPY OF THE CAD FILES THAT REPRESENT THESE IMPROVEMENTS; SANDLIN SERVICES, LLC AND IT'S ASSOCIATES TAKE NO RESPONSIBILITY FOR THE LOCATION OF THESE IMPROVEMENTS IN ANY COORDINATE SYSTEM. DIGITAL FILES USED TO PRODUCE THESE PLANS WERE PARTIALLY CREATED BY PARTIES OTHER THAN SANDLIN SERVICES, LLC AND ARE NOT INTENDED FOR USE IN CONSTRUCTION STAKING. VERTICAL AND HORIZONTAL DATA SHALL BE INDEPENDENTLY VERIFIED BY CONTRACTOR'S R.P.L.S.
5. SANDLIN SERVICES, LLC HAS ENDEAVORED TO DESIGN THESE PLANS COMPLIANT WITH ADA/TDLR AND OTHER ACCESSIBILITY REQUIREMENTS. HOWEVER, THE CONTRACTOR SHALL NOT BE RELIEVED OF ANY RESPONSIBILITY FOR CONSTRUCTING THESE IMPROVEMENTS COMPLIANT WITH ALL APPLICABLE ACCESSIBILITY STANDARDS. IF THE CONTRACTOR NOTICES ANY DISCREPANCIES BETWEEN THESE PLANS AND ACCESSIBILITY LAWS/RULES, HE IS TO STOP WORK IN THE AREA OF CONFLICT AND NOTIFY THE ENGINEER IMMEDIATELY FOR A RESOLUTION AND/OR REVISION TO THESE PLANS. SANDLIN SERVICES, LLC SHALL NOT BE HELD RESPONSIBLE FOR CONSTRUCTING THIS SITE COMPLIANT WITH ACCESSIBILITY LAWS/RULES REGARDLESS OF WHAT IS SHOWN IN THESE PLANS.

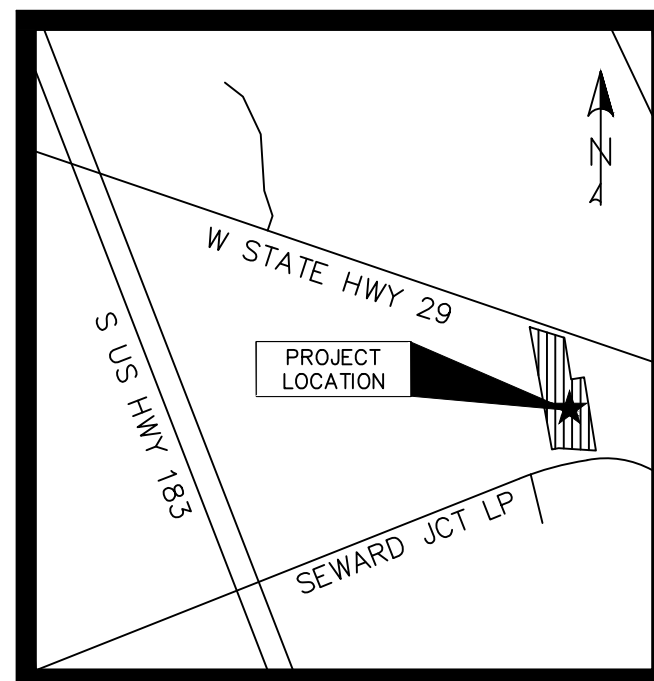

PROJECT LOCATION MAP
N.T.S.

COVER PAGE
SHEET 1 OF 10
P.E.C. LIBERTY HILL EAPP
EXCELL FUELING SYSTEMS



GENERAL NOTES AND REQUIREMENTS:

1. ALL CONTRACTORS MUST CONFINE THEIR ACTIVITIES TO THE WORK AREA. NO ENCROACHMENTS OUTSIDE OF THE WORK AREA WILL BE ALLOWED. ANY DAMAGE RESULTING THEREFROM SHALL BE CONTRACTOR'S SOLE RESPONSIBILITY TO REPAIR.
2. THE CONTRACTOR SHALL PROTECT ALL EXISTING STRUCTURES, UTILITIES, MANHOLES, POLES, GUY WIRES, VALVE COVERS, VAULT LIDS, FIRE HYDRANTS, COMMUNICATION BOXES/PEDESTALS, AND OTHER FACILITIES TO REMAIN, AND SHALL REPAIR ANY DAMAGES AT NO COST TO THE OWNER.
3. THE CONTRACTOR SHALL IMMEDIATELY REPAIR OR REPLACE ANY PHYSICAL DAMAGE TO PRIVATE PROPERTY OR PUBLIC IMPROVEMENTS, INCLUDING BUT NOT LIMITED TO: FENCES, WALLS, SIGNS, PAVEMENT, CURBS, UTILITIES, SIDEWALKS, GRASS, TREES, LANDSCAPING, AND IRRIGATION SYSTEMS, ETC.... TO ORIGINAL CONDITION OR BETTER AT NO COST TO THE OWNER.
4. ALL AREAS IN EXISTING RIGHT-OF-WAY DISTURBED BY SITE CONSTRUCTION SHALL BE REPAIRED TO ORIGINAL CONDITION OR BETTER, INCLUDING AS NECESSARY, GRADING, LANDSCAPING, CULVERTS, AND PAVEMENT.
5. THE CONTRACTOR SHALL SALVAGE ALL EXISTING POWER POLES, SIGNS, WATER VALVES, FIRE HYDRANTS, METERS, ETC... THAT ARE TO BE RELOCATED DURING CONSTRUCTION.
6. CONTRACTOR SHALL MAINTAIN ADEQUATE SITE DRAINAGE DURING ALL PHASES OF CONSTRUCTION, INCLUDING MAINTAINING EXISTING DITCHES OR CULVERTS FREE OF OBSTRUCTIONS AT ALL TIMES.
7. SITE SAFETY IS SOLELY THE RESPONSIBILITY OF THE CONTRACTOR.
8. THESE PLANS DO NOT EXTEND TO OR INCLUDE DESIGNS OR SYSTEMS PERTAINING TO THE SAFETY OF THE CONTRACTOR OR ITS EMPLOYEES, AGENTS, OR REPRESENTATIVES IN THE PERFORMANCE OF THE WORK. THE ENGINEER'S SEAL HEREON DOES NOT EXTEND TO ANY SUCH SAFETY SYSTEM. THE CONTRACTOR SHALL BE RESPONSIBLE FOR ALL REQUIRED SAFETY PROCEDURES AND PROGRAMS.
9. SIGNS RELATED TO SITE OPERATION OR SAFETY ARE NOT INCLUDED IN THESE PLANS.
10. CONTRACTOR OFFICE AND STAGING AREA SHALL BE AGREED ON BY THE OWNER AND CONTRACTOR PRIOR TO BEGINNING OF CONSTRUCTION. CONTRACTOR IS RESPONSIBLE FOR ALL PERMITTING REQUIREMENTS FOR THE CONSTRUCTION OFFICE, TRAILER, STORAGE, AND STAGING OPERATIONS AND LOCATIONS.
11. LIGHT POLES, SIGNS, AND OTHER OBSTRUCTIONS SHALL NOT BE PLACED IN ACCESSIBLE ROUTES.
12. TOP RIM ELEVATIONS OF ALL EXISTING AND PROPOSED MANHOLES SHALL BE COORDINATED WITH TOP OF PAVEMENT OR FINISHED GRADE AND SHALL BE ADJUSTED TO BE FLUSH WITH THE ACTUAL FINISHED GRADE AT THE TIME OF PAVING.
13. CONTRACTOR SHALL ADJUST ALL EXISTING AND PROPOSED VALVES, FIRE HYDRANTS, AND OTHER UTILITY APPURTENANCES TO MATCH ACTUAL FINISHED GRADES AT THE TIME OF PAVING.
14. THE CONTRACTOR IS RESPONSIBLE FOR CONSTRUCTION SEQUENCING AND PHASING AND SHALL CONTACT THE APPROPRIATE CITY OFFICIALS, INCLUDING BUILDING OFFICIAL, ENGINEERING INSPECTOR, AND FIRE MARSHALL TO LEARN OF ANY REQUIREMENTS.
15. CONTRACTOR IS RESPONSIBLE FOR PREPARATION, SUBMITTAL, AND APPROVAL BY THE CITY OF A TRAFFIC CONTROL PLAN PRIOR TO THE START OF CONSTRUCTION, AND THEN THE IMPLEMENTATION OF THE PLAN.
16. THE CONTRACTOR SHALL VISIT THE SITE PRIOR TO BIDDING TO DETERMINE EXISTING CONDITIONS.
17. THE CONTRACTOR SHALL BE RESPONSIBLE FOR PROVIDING AS-BUILT PLANS TO THE ENGINEER AND CITY IDENTIFYING ALL DEVIATIONS AND VARIATIONS FROM THESE PLANS MADE DURING CONSTRUCTION.
18. THE CONTRACTOR SHALL COMPLY WITH ALL LOCAL, STATE, AND FEDERAL EROSION CONTROL AND WATER QUALITY REQUIREMENTS.
19. PRIOR TO COMMENCEMENT OF CONSTRUCTION, THE CONTRACTOR SHALL VERIFY ALL DIMENSIONS AND CONDITIONS AFFECTING THEIR WORK WITH THE ACTUAL CONDITION AT THE PROJECT SITE. IN ADDITION, THE CONTRACTOR MUST VERIFY THE ENGINEER'S LINE AND GRADE STAKES. IF THERE ARE ANY DISCREPANCIES FROM WHAT IS SHOWN ON THE CONSTRUCTION PLANS, THE CONTRACTOR MUST IMMEDIATELY PROVIDE THE INFORMATION TO THE ENGINEER BEFORE DOING ANY WORK, OTHERWISE, THE CONTRACTOR ASSUMES FULL RESPONSIBILITY. IN THE EVENT OF A DISAGREEMENT BETWEEN THE CONSTRUCTION PLANS, STANDARD SPECIFICATIONS, AND/OR DETAILS. THE CONTRACTOR SHALL SECURE WRITTEN INSTRUCTIONS FROM THE ENGINEER PRIOR TO PROCEEDING WITH ANY PART OF THE WORK AFFECTED BY OMISSIONS OR DISCREPANCIES. IF THE CONTRACTOR FAILS TO SECURE WRITTEN INSTRUCTIONS FROM THE ENGINEER, THE CONTRACTOR WILL BE CONSIDERED TO HAVE PROCEEDED AT THEIR OWN RISK AND EXPENSE. IN THE EVENT OF ANY DOUBT OR QUESTION ARISING WITH RESPECT TO SPECIFICATIONS, THE DECISION OF THE ENGINEER SHALL BE FINAL.
20. THE CONTRACTOR SHALL COMPLY WITH JURISDICTIONAL "GENERAL NOTES" FOR CONSTRUCTION, JURISDICTIONAL NOTES SHALL SUPERCEDE ANY CONFLICT WITH THE SANDLIN SERVICES, LLC. NOTES.
21. IT IS THE CONTRACTOR'S RESPONSIBILITY TO CONTACT THE VARIOUS UTILITY COMPANIES WHICH MAY HAVE BURIED OR AERIAL UTILITIES WITH OR NEAR THE CONSTRUCTION AREA BEFORE COMMENCING WORK TO HAVE THEM LOCATE THEIR EXISTING UTILITIES PRIOR TO CONSTRUCTION. CONTRACTOR SHALL USE EXTREME CAUTION AS THE SITE CONTAINS VARIOUS KNOWN AND UNKNOWN PUBLIC AND PRIVATE UTILITIES.
22. CONTRACTOR SHALL COORDINATE ALL UTILITY LINE CROSSINGS TO ENSURE ALL PIPES MAINTAIN MINIMUM COVER, MINIMUM CLEARANCES, AND PROPER SEPARATION.
23. THE LOCATIONS, ELEVATIONS, DEPTH, AND DIMENSIONS OF EXISTING UTILITIES SHOWN ON THE PLANS WERE OBTAINED FROM AVAILABLE UTILITY COMPANY MAPS AND PLANS, AND ARE CONSIDERED APPROXIMATE. THE ENGINEER SHALL BE NOTIFIED WHEN A PROPOSED IMPROVEMENT CONFLICTS WITH AN EXISTING UTILITY.
24. THE CONTRACTOR IS RESPONSIBLE FOR COORDINATING ANY ADJUSTMENTS AND RELOCATIONS OF EXISTING UTILITIES THAT CONFLICT WITH THE PROPOSED IMPROVEMENTS THAT MAY BE ENCOUNTERED THAT ARE UNKNOWN AT THIS TIME AND NOT SHOWN ON THESE PLANS. CONTRACTOR SHALL ARRANGE FOR OR PROVIDE, ALL GAS, TELECOMMUNICATIONS, CABLE, OVERHEAD AND UNDERGROUND POWER LINE, AND UTILITY POLE ADJUSTMENTS NEEDED. CONTRACTOR IS RESPONSIBLE FOR COORDINATING INSTALLATION OF FRANCHISE UTILITIES THAT ARE NECESSARY FOR ON-SITE AND OFF-SITE CONSTRUCTION, AND SERVICE TO THE PROPOSED DEVELOPMENT.
25. THE IMPLIED PRESENCE OR ABSENCE OF UTILITIES IS NOT TO BE CONSTRUED BY THE OWNER, ENGINEER, CONTRACTOR, OR SUBCONTRACTORS TO BE AN ACCURATE AND COMPLETE REPRESENTATION OF UTILITIES THAT MAY OR MAY NOT EXIST ON THE CONSTRUCTION SITE. BURIED AND ABOVE GROUND UTILITY LOCATION, IDENTIFICATION AND MARKING IS THE SOLE RESPONSIBILITY OF THE CONTRACTOR. REROUTING, DISCONNECTION, PROTECTION, ETC. OF ANY UTILITIES MUST BE COORDINATED BETWEEN THE CONTRACTOR, UTILITY COMPANY, AND OWNER. SITE SAFETY, INCLUDING THE AVOIDANCE OF HAZARDS ASSOCIATED WITH BURIED AND ABOVE GROUND UTILITIES, REMAINS THE SOLE RESPONSIBILITY OF THE THE CONTRACTOR. THE CONTRACTOR SHALL BE RESPONSIBLE FOR PROTECTING UTILITY PROPERTY FROM CONSTRUCTION OPERATIONS.
26. THE CONTRACTOR TO FIELD VERIFY LOCATION AND ELEVATION OF ALL EXISTING UTILITIES PRIOR TO CONSTRUCTION.
27. THE CONTRACTOR SHALL BE FULLY RESPONSIBLE FOR ALL DAMAGES DUE TO THE CONTRACTOR'S FAILURE TO EXACTLY LOCATE AND PRESERVE ALL UTILITIES. THE OWNER OR ENGINEER WILL ASSUME NOT LIABILITY FOR ANY DAMAGES SUSTAINED OR COST INCURRED BECAUSE OF THE OPERATIONS IN THE VICINITY OF EXISTING UTILITIES OR STRUCTURES.
21. ALL SHOP DRAWINGS AND OTHER DOCUMENTS THAT REQUIRE ENGINEER REVIEW SHALL BE SUBMITTED BY THE CONTRACTOR SUFFICIENTLY IN ADVANCE OF CONSTRUCTION OF THAT ITEM, SO THAT NO LESS THAN 10 BUSINESS DAYS FOR REVIEW AND RESPONSE IS AVAILABLE.
22. ALL NECESSARY INSPECTIONS AND/OR CERTIFICATIONS REQUIRED BY CODES, JURISDICTIONAL AGENCIES, AND/OR UTILITY SERVICE COMPANIES SHALL BE PERFORMED PRIOR TO USE OF THE FACILITY AND THE FINAL CONNECTION OF SERVICES.
23. CONTRACTOR SHALL ARRANGE FOR REQUIRED CITY INSPECTIONS.
24. CONTRACTOR'S BID PRICE SHALL INCLUDE ALL INSPECTION FEE.
25. ALL SYMBOLS SHOWN ON THESE PLANS ARE FOR PRESENTATION PURPOSES ONLY AND ARE NOT TO SCALE. CONTRACTOR SHALL COORDINATE FINAL SIZES AND LOCATIONS WITH APPROPRIATE CITY INSPECTOR. REFER TO ARCHITECTURAL AND STRUCTURAL PLANS FOR ALL FINAL BUILDING DIMENSIONS.
26. COMPLIANCE WITH COMMERCIAL AND MULTI-FAMILY RECYCLING ORDINANCE IS MANDATORY FOR MULTI-FAMILY COMPLEXES WITH 100 OR MORE UNITS AND BUSINESSES WITH 100 OR MORE EMPLOYEES.
27. CONTRACTOR PARKING AND LAYDOWN AREAS SHALL BE COORDINATED WITH THE OWNER.
28. THE CONTRACTOR SHALL PROVIDE ANY FINANCIAL SURETIES REQUIRED AS PART OF ANY PERMIT.
29. CONTRACTOR SHALL BE RESPONSIBLE FOR PREPARING AND SUBMITTING ELECTRONIC AS-BUILT DRAWINGS FOR UTILITIES AND DETENTION AREAS TO THE OWNER AND ENGINEER FOR REVIEW AND APPROVAL PRIOR TO PROJECT ACCEPTANCE.
30. CONTRACTOR SHALL SUBMIT SHOP DRAWINGS FOR ALL ITEMS INCORPORATED INTO THE WORK FOR ENGINEER REVIEW AND APPROVAL OF MINIMUM OF 4 WEEKS PRIOR TO ORDERING.
31. REFERENCES TO "INSPECTION" OR "INSPECTOR" IN THE SPECIFICATIONS SHALL NOT CREATE, IMPOSE, OR GIVE RISE TO ANY DUTY OWED BY THE OWNER OR ENGINEER TO THE CONTRACTOR, ANY SUBCONTRACTOR, OR ANY SUPPLIER. ALL IMPROVEMENTS SHALL BE SUBJECT TO INSPECTION BY A DULY AUTHORIZED AND QUALIFIED OWNER'S REPRESENTATIVE BOTH DURING THE COURSE OF CONSTRUCTION AND AFTER CONSTRUCTION IS COMPLETE. THE INSPECTOR SHALL HAVE AUTHORITY OVER MATERIALS OF CONSTRUCTION, METHODS OF CONSTRUCTION, AND WORKMANSHIP, TO ENSURE COMPLIANCE WITH WORKING DRAWINGS AND SPECIFICATIONS. THE CONTRACTOR SHALL PROVIDE FOR REASONABLE TESTS AND PROOF OF QUALITY OF MATERIALS AS REQUESTED BY THE INSPECTOR. UPON DUE CAUSE, WHICH SHALL INCLUDE WEATHER CONDITION, WORKMANSHIP OR NON-ADHERENCE TO THE APPROVED PLANS AND SPECIFICATIONS, THE INSPECTOR SHALL HAVE THE AUTHORITY TO STOP CONSTRUCTION.
32. WHERE SECTION, SUB-SECTION, SUBDIVISION, OR PROPERTY MONUMENTS ARE ENCOUNTERED, THE OWNER'S REPRESENTATIVE SHALL BE NOTIFIED BEFORE SUCH MONUMENTS ARE REMOVED. THE CONTRACTOR SHALL PROTECT AND PRESERVE ALL PROPERTY MARKERS UNTIL AN OWNER OR AUTHORIZED SURVEYOR HAS WITNESSED OR REFERENCED THEIR LOCATION.
33. CONTRACTOR SHALL NOTIFY THE APPROPRIATE AGENCY A MINIMUM OF 48 HOURS PRIOR TO CONNECTING TO OR INSTALLING ANY PUBLIC SEWER OR WATER MAINS.

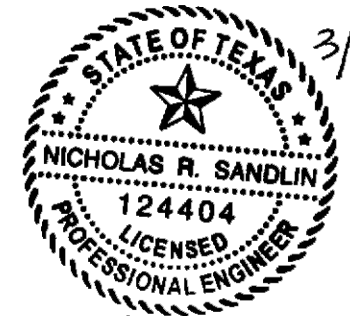

3/20/2024

Nicholas R. Sandlin

REVISION RECORD

--

GENERAL NOTES (1 OF 4)
SHEET 2 OF 10
P.E.C. LIBERTY HILL EAPP
EXCELL FUELING SYSTEMS

SANDLIN
ENGINEERING | CONSULTING
SERVICES, LLC

TBPELS FIRM #21356
9111 JOLLVILLE RD., STE. 212
AUSTIN, TX 78759

TEXAS COMMISSION ON ENVIRONMENTAL QUALITY CONTRIBUTING ZONE PLAN GENERAL CONSTRUCTION NOTES

1. A WRITTEN NOTICE OF CONSTRUCTION MUST BE SUBMITTED TO THE TCEQ REGIONAL OFFICE AT LEAST 48 HOURS PRIOR TO THE START OF ANY GROUND DISTURBANCE OR CONSTRUCTION ACTIVITIES. THIS NOTICE MUST INCLUDE:
 - THE NAME OF THE APPROVED PROJECT;
 - THE ACTIVITY START DATE; AND
 - THE CONTACT INFORMATION OF THE PRIME CONTRACTOR.
2. ALL CONTRACTORS CONDUCTING REGULATED ACTIVITIES ASSOCIATED WITH THIS PROJECT SHOULD BE PROVIDED WITH COMPLETE COPIES OF THE APPROVED CONTRIBUTING ZONE PLAN (CZP) AND THE TCEQ LETTER INDICATING THE SPECIFIC CONDITIONS OF ITS APPROVAL. DURING THE COURSE OF THESE REGULATED ACTIVITIES, THE CONTRACTOR(S) SHOULD KEEP COPIES OF THE APPROVED PLAN AND APPROVAL LETTER ONSITE.
3. NO HAZARDOUS SUBSTANCE STORAGE TANK SHALL BE INSTALLED WITHIN 150 FEET OF A WATER SUPPLY SOURCE, DISTRIBUTION SYSTEM, WELL, OR SENSITIVE FEATURE.
4. PRIOR TO BEGINNING ANY CONSTRUCTION ACTIVITY, ALL TEMPORARY EROSION AND SEDIMENTATION (E&S) CONTROL MEASURES MUST BE PROPERLY INSTALLED AND MAINTAINED IN ACCORDANCE WITH THE MANUFACTURERS SPECIFICATIONS. IF INSPECTIONS INDICATE A CONTROL HAS BEEN USED INAPPROPRIATELY, OR INCORRECTLY, THE APPLICANT MUST REPLACE OR MODIFY THE CONTROL FOR SITE SITUATIONS. THESE CONTROLS MUST REMAIN IN PLACE UNTIL THE DISTURBED AREAS HAVE BEEN PERMANENTLY STABILIZED.
5. ANY SEDIMENT THAT ESCAPES THE CONSTRUCTION SITE MUST BE COLLECTED AND PROPERLY DISPOSED OF BEFORE THE NEXT RAIN EVENT TO ENSURE IT IS NOT WASHED INTO SURFACE STREAMS, SENSITIVE FEATURES, ETC.
6. SEDIMENT MUST BE REMOVED FROM THE SEDIMENT TRAPS OR SEDIMENTATION BASINS WHEN IT OCCUPIES 50% OF THE BASIN'S DESIGN CAPACITY.
7. LITTER, CONSTRUCTION DEBRIS, AND CONSTRUCTION CHEMICALS EXPOSED TO STORMWATER SHALL BE PREVENTED FROM BEING DISCHARGED OFFSITE.
8. ALL EXCAVATED MATERIAL THAT WILL BE STORED ON-SITE MUST HAVE PROPER E&S CONTROLS.
9. IF PORTIONS OF THE SITE WILL HAVE A CEASE IN CONSTRUCTION ACTIVITY LASTING LONGER THAN 14 DAYS, SOIL STABILIZATION IN THOSE AREAS SHALL BE INITIATED AS SOON AS POSSIBLE PRIOR TO THE 14TH DAY OF INACTIVITY. IF ACTIVITY WILL RESUME PRIOR TO THE 21ST DAY, STABILIZATION MEASURES ARE NOT REQUIRED. IF DROUGHT CONDITIONS OR INCLEMENT WEATHER PREVENT ACTION BY THE 14TH DAY, STABILIZATION MEASURES SHALL BE INITIATED AS SOON AS POSSIBLE.
10. THE FOLLOWING RECORDS SHOULD BE MAINTAINED AND MADE AVAILABLE TO THE TCEQ UPON REQUEST:
 - THE DATES WHEN MAJOR GRADING ACTIVITIES OCCUR;
 - THE DATES WHEN CONSTRUCTION ACTIVITIES TEMPORARILY OR PERMANENTLY CEASE ON A PORTION OF THE SITE; AND
 - THE DATES WHEN STABILIZATION MEASURES ARE INITIATED.
11. THE HOLDER OF ANY APPROVED CZP MUST NOTIFY THE APPROPRIATE REGIONAL OFFICE IN WRITING AND OBTAIN APPROVAL FROM THE EXECUTIVE DIRECTOR PRIOR TO INITIATING ANY OF THE FOLLOWING:
 - A. ANY PHYSICAL OR OPERATIONAL MODIFICATION OF ANY BEST MANAGEMENT PRACTICES (BMPS) OR STRUCTURE(S), INCLUDING BUT NOT LIMITED TO TEMPORARY OR PERMANENT PONDS, DAMS, BERMS, SILT FENCES, AND DIVERSIONARY STRUCTURES;
 - B. ANY CHANGE IN THE NATURE OR CHARACTER OF THE REGULATED ACTIVITY FROM THAT WHICH WAS ORIGINALLY APPROVED;
 - C. ANY CHANGE THAT WOULD SIGNIFICANTLY IMPACT THE ABILITY TO PREVENT POLLUTION OF THE EDWARDS AQUIFER; OR
 - D. ANY DEVELOPMENT OF LAND PREVIOUSLY IDENTIFIED AS UNDEVELOPED IN THE APPROVED CONTRIBUTING ZONE PLAN.

AUSTIN REGIONAL OFFICE
 12100 PARK 35 CIRCLE, BUILDING A
 AUSTIN, TEXAS 78753-1808
 PHONE (512) 339-2929
 FAX (512) 339-3795

SAN ANTONIO REGIONAL OFFICE
 14250 JUDSON ROAD
 SAN ANTONIO, TEXAS 78233-4480
 PHONE (210) 490-3096
 FAX (210) 545-4329

REVISION RECORD

NOTICE: ALTERATION OF A SEALED DRAWING WITHOUT PROPER NOTIFICATION TO THE ENGINEER OF RECORD IS A VIOLATION OF THE TEXAS ENGINEERING PRACTICES ACT

SAFETY

1. CONTRACTOR SHALL USE ALL NECESSARY SAFETY PRECAUTIONS TO AVOID CONTACT WITH OVERHEAD AND UNDERGROUND POWER LINES. CONTRACTOR SHALL COMPLY WITH ALL APPLICABLE LOCAL, STATE, FEDERAL, AND UTILITY OWNER REGULATIONS PERTAINING TO WORK SETBACKS FROM POWER LINES.
2. ESTABLISH FIRE ZONES AS SHOWN ON SITE BY PAINTING CURB RED. STENCIL THE WORDS, "FIRE ZONE/TOW-AWAY ZONE", IN WHITE LETTERS AT LEAST 3 INCHES HIGH AT 35-FOOT INTERVALS ALONG THE CURB. ALSO, SIGNS SHALL BE POSTED AT BOTH ENDS OF A FIRE ZONE. ALTERNATE MARKING OF THE FIRE LANES MY BE APPROVED BY THE FIRE CHIEF PROVIDED THE FIRE LANES ARE CLEARLY IDENTIFIED AT BOTH ENDS AND AT INTERVALS NOT TO EXCEED 35 FEET.
3. WARNING ARE REQUIRED TO BE PLACED UNDER THE OVERHEAD ELECTRIC LINES TO MAKE ALL PERSONNEL AWARE OF THE ELECTRIC HAZARD.
4. ALL FDC'S TO BE TWO 2 1/2 INCH SIAMESE CONNECTIONS.
5. THE CONTRACTOR SHALL FURNISH, ERECT, AND MAINTAIN MARKINGS AND ASSOCIATED HAZARD WARNING LIGHTS, DELINEATOR FENCE, AND OTHER ASSOCIATED FACILITIES AS REQUIRED FOR OPEN TRENCHES, EXCAVATIONS. TEMPORARY STOCK PILES, AND PARKED CONSTRUCTION EQUIPMENT THAT MAY POSE A POTENTIAL HAZARD AS PART OF THE DAILY OPERATIONS AT THIS SITE. CONTRACTOR IS SOLELY RESPONSIBLE FOR SITE SAFETY.

CONSTRUCTION MEANS, METHODS, & SAFETY PROTECTION NOTES:

THE CONTRACTOR SHALL BE RESPONSIBLE FOR COMPLIANCE WITH ALL FEDERAL, STATE, AND LOCAL LAWS, INCLUDING OSHA STANDARDS AND WITH ANY OTHER APPLICABLE LAWS, ORDINANCES, RULES, REGULATIONS AND ORDERS OF ANY PUBLIC BODY HAVING JURISDICTION FOR THE SAFETY OF PERSONS OR PROPERTY OR TO PROTECT THEM FROM DAMAGE, INJURY OR LOSS. THE CONTRACTOR SHALL PROVIDE ALL SAFEGUARDS, SAFETY DEVICES, AND PROTECTIVE EQUIPMENT AND SHALL BE RESPONSIBLE FOR INITIATING, MAINTAINING, AND SUPERVISING ALL SAFETY PRECAUTIONS AND PROGRAMS UTILIZED BY THE CONTRACTOR AND HIS SUB-CONTRACTORS IN THE PERFORMANCE OF THEIR WORK AND SHALL TAKE ANY OTHER ACTIONS NECESSARY TO PROTECT THE LIFE AND HEALTH OF EMPLOYEES ON THE JOB AND THE SAFETY OF THE PUBLIC AND TO PROTECT PROPERTY IN CONNECTION WITH THE PERFORMANCE OF WORK ON THIS PROJECT. THE CONTRACTOR SHALL BE RESPONSIBLE FOR THE CONSTRUCTION MEANS, METHODS, TECHNIQUES OR PROCEDURES, EQUIPMENT, AND FOR SAFETY PRECAUTIONS OR PROGRAMS, UNLESS SUCH MEANS AND EQUIPMENT ARE SPECIFIED IN THE CONTRACT DOCUMENTS. THE CONTRACTOR SHALL COMPLY WITH SECTION 108.06 LABOR, METHODS, AND EQUIPMENT OF THE "STANDARD SPECIFICATIONS".

STORM WATER DISCHARGE AUTHORIZATION

THE CONTRACTOR AND WHERE APPLICABLE SUBCONTRACTORS ARE RESPONSIBLE FOR:

1. COMPLIANCE WITH ALL TCEQ AND EPA STORM WATER POLLUTION PREVENTION REQUIREMENTS.
2. ENSURING THAT ALL PRIMARY OPERATORS SUBMIT A NOI TO TCEQ AT LEAST 7 DAYS PRIOR CONSTRUCTION. AND THEY PROVIDE A COPY OF ALL SIGNED NOI'S TO THE OPERATOR OF ANY MS4 RECEIVING DISCHARGE FROM THE SITE.
3. IMPLEMENTATION OF THE STORM WATER POLLUTION PREVENTION PLAN (SWPPP), IF IT APPLIES, IE. POST SITE NOTICE, INSPECTIONS, DOCUMENTATION AND SUBMISSION OF ANY INFORMATION, SUCH AS NOI, REQUIRED BY TCEQ AND EPA.
4. SIGNING THE REQUIRED CERTIFICATION STATEMENT ACKNOWLEDGING THEIR RESPONSIBILITIES AS STATED IN THE SWPPP IF PROVIDING SERVICES RELATED TO SWPPP.
5. SUBMITTING TO THE CITY, AND RETAINING ON SITE DURING CONSTRUCTION, A COPY OF THE SWPPP INCLUDING NOI, SITE NOTICE, CONTRACTOR CERTIFICATION, AND ANY REVISIONS.
6. PRIMARY OPERATOR IS RESPONSIBLE FOR SUBMITTING A NOTICE OF TERMINATION (NOT) TO TCEQ WITH 30 DAYS AFTER ALL SOIL DISTURBING ACTIVITIES HAVE BEEN COMPLETED AND A VEGETATIVE COVER HAS BEEN ESTABLISHED ON ALL UNPAVED AREA AND ALL AREAS NOT COVERED BY STRUCTURES, A TRANSFER OF OPERATIONAL CONTROL HAS OCCURRED, OR THE OPERATOR HAS AN ALTERNATIVE AUTHORIZATION UNDER A DIFFERENT PERMIT. A COPY OF THE NOT SHALL BE PROVIDED TO THE OPERATOR OF ANY MS4 RECEIVING DISCHARGE FROM THE SITE.

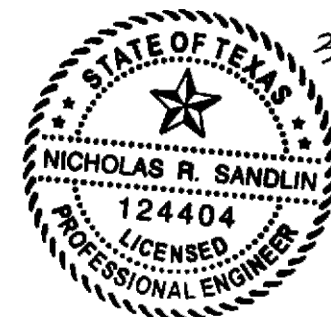

3/20/2024

Nicholas R. Sandlin

PRE-CONSTRUCTION NOTES:

1. PRIOR TO SCHEDULING THE PRE-CONSTRUCTION MEETING ENSURE THAT ALL REQUIRED NOTICES AND PERMITS ARE POSTED AND THE CERTIFIED INSPECTOR FOR YOUR SITE HAS UPLOADED A SWP3 INSPECTION REPORT TO YOUR ACCOUNT THAT CONFIRMS THAT THE FIRST PHASE OF TEMPORARY ESC HAVE BEEN INSTALLED PER PLANS AND SPECIFICATIONS.
2. FAILURE TO FOLLOW THE PRE-CONSTRUCTION MEETING REQUIREMENTS MAY RESULT IN WORK STOPPAGE AND ADDITIONAL PERMIT FEES.
3. PROVIDE 48 HR. MINIMUM NOTICE TO SCHEDULE THE PRE-CONSTRUCTION MEETING.
4. PROVIDE A 1/2 SIZE SET OF PLANS FOR THE INSPECTOR AT THE PRE-CONSTRUCTION.
5. PROVIDE AN ANTICIPATED CONSTRUCTION SCHEDULE AT THE PRE-CONSTRUCTION.
6. BRING YOUR SWP3 FOR COMPLETENESS CHECK AT THE PRE-CONSTRUCTION.
7. ALL DEVELOPMENT SHALL BE IN ACCORDANCE WITH THE PLANS APPROVED BY TRAVIS COUNTY.
8. SCHEDULE YOUR PROJECTS PRE-CONSTRUCTION MEETING THROUGH THE MYPERMITNOW.ORG ACCOUNT AFTER THE INITIAL 3RD PARTY SWP3 INSPECTION REPORT HAS BEEN UPLOADED AND ALL PERMITS AND NOTICES HAVE BEEN POSTED, THEN FOLLOW UP WITH EMAILS TO THE ENVIRONMENTAL INSPECTOR AT ENV-INSPECTION@TRAVISCOUNTYTX.GOV

GENERAL NOTES (2 OF 4)

SHEET 3 OF 10

P.E.C. LIBERTY HILL EAPP

EXCELL FUELING SYSTEMS

SANDLIN
 SERVICES, LLC

TBPELS FIRM #21356
 9111 JOLLVILLE RD., STE. 212
 AUSTIN, TX 78759

ACCESSIBLE PARKING NOTE:

1. BEFORE PLACING PAVEMENT, CONTRACTOR SHALL VERIFY THAT SUITABLE HANDICAPPED ROUTES (PER ADA) EXIST TO AND FROM DESIGNATED DOORS. IN NO CASE SHALL HANDICAP RAMP SLOPES EXCEED 1 VERTICAL TO 12 HORIZONTAL. IN NO CASE SHALL SIDEWALK CROSS SLOPES EXCEED 2.0 PERCENT. IN NO CASE SHALL LONGITUDINAL SIDEWALK SLOPES EXCEED 5.0 PERCENT. CONTRACTOR SHALL CONTACT ENGINEER PRIOR TO PAVING IF ANY EXCESSIVE SLOPES ARE ENCOUNTERED. NO CONTRACTOR CHANGE ORDERS WILL BE ACCEPTED FOR ADA COMPLIANCE ISSUES.
2. ALL ACCESSIBLE SPACES AND ACCESSIBLE ROUTES SHALL COMPLY WITH THE TEXAS ACCESSIBILITY STANDARDS (TAS) AND THE CITY REQUIREMENTS.
3. PARKING SPACES AND ACCESS AISLES SHALL BE LEVEL WITH SURFACE SLOPES NOT EXCEEDING 1:50 (2%) IN ALL DIRECTIONS. CURB RAMPS COMPLYING WITH TAS SHALL BE PROVIDED AT ALL PASSENGER LOADING ZONES.
4. EACH ACCESSIBLE PARKING SPACE SHALL BE DESIGNATED AS RESERVED BY A VERTICALLY MOUNTED OR SUSPENDED SIGN SHOWING THE SYMBOL OF ACCESSIBILITY PER TAS. SPACES COMPLYING WITH TAS SHALL HAVE AN ADDITIONAL SIGN "VAN ACCESSIBLE" MOUNTED BELOW THE SYMBOL OF ACCESSIBILITY WHEN REQUIRED.
 - (A) CHARACTERS AND SYMBOLS ON SUCH SIGNS SHALL BE LOCATED 60" MINIMUM ABOVE THE GROUND, FLOOR, OR PAVING SURFACE SO THEY CANNOT BE OBSCURED BY A VEHICLE PARKED IN THE SPACE.
 - (B) SIGNS LOCATED WITHIN AN ACCESSIBLE ROUTE SHALL COMPLY WITH TAS.
 - (C) CHARACTERS AND SYMBOLS ON OVERHEAD SIGNS SHALL COMPLY WITH TAS.
5. SLOPES OF CURB RAMPS SHALL COMPLY WITH TAS. TRANSITIONS FROM RAMPS TO WALKS, GUTTERS, OR STREETS SHALL BE FLUSH AND FREE OF ABRUPT CHANGES. MAXIMUM SLOPES OF ADJOINING GUTTERS, ROAD SURFACE IMMEDIATELY ADJACENT TO THE CURB RAMP, OR ACCESSIBLE ROUTE SHALL NOT EXCEED 1:20.
6. SURFACES OF CURB RAMPS SHALL COMPLY WITH TAS.
 - (A) TEXTURES SHALL CONSIST OF EXPOSED CRUSHED STONE AGGREGATE, ROUGHENED CONCRETE, RUBBER, RAISED ABRASIVE STRIPS, OR GROOVES EXTENDING THE FULL WIDTH AND DEPTH OF THE CURB RAMP. SURFACES THAT ARE RAISED, ETCHED, OR GROOVED IN A WAY THAT WOULD ALLOW WATER TO ACCUMULATE ARE PROHIBITED.
 - (B) FOR PURPOSES OF WARNING, THE FULL WIDTH AND DEPTH OF CURB RAMPS SHALL HAVE A LIGHT REFLECTIVE VALUE AND TEXTURE THAT SIGNIFICANTLY CONTRASTS WITH THAT OF ADJOINING PEDESTRIAN ROUTES.
7. EVERY HANDICAP ACCESSIBLE PARKING SPACE SHALL BE IDENTIFIED BY A SIGN CENTERED 5 FEET ABOVE THE PARKING SURFACE, AT THE HEAD OF THE PARKING SPACE. THE SIGN MUST INCLUDE THE INTERNATIONAL SYMBOL OF ACCESSIBILITY. SUCH SIGNS SHALL NOT BE OBSCURED BY A VEHICLE PARKED THE SPACE AND SHALL MEET THE CRITERIA SET FORTH IN UBC AND ANSI.
8. SLOPES ON ACCESSIBLE ROUTES MAY NOT EXCEED 1:20 UNLESS DESIGNED AS A RAMP.
9. THE MAXIMUM SLOPE OF A RAMP IN NEW CONSTRUCTION IS 1:12. THE MAXIMUM RISE FOR ANY RAMP RUN IS 30 IN.
10. ACCESSIBLE ROUTES MUST HAVE A CROSS-SLOPE NO GREATER THAN 1:30.
11. GROUND SURFACES ALONG ACCESSIBLE ROUTES MUST BE STABLE, FIRM, AND SLIP RESISTANT.

TRAFFIC CONTROL NOTES:

1. ALL SIGNS, PAVEMENT MARKINGS, AND OTHER TRAFFIC CONTROL DEVICES SHALL CONFORM TO THE "TEXAS MANUAL ON UNIFORM TRAFFIC CONTROL DEVICES".
2. ALL FIRE DEPARTMENT ACCESS DRIVES/ROADS TO HAVE A MINIMUM 14' VERTICAL CLEARANCE.
3. ALL PARKING SPACES SHALL HAVE A MINIMUM 7'-0" VERTICAL CLEARANCE.
4. ALL LANDSCAPED AREAS ARE TO BE PROTECTED BY SIX-INCH WHEEL CURBS, WHEELSTOPS, OR OTHER APPROVED BARRIERS AS PER ECM.
5. ADEQUATE BARRIERS BETWEEN ALL VEHICULAR USE AREAS AND ADJACENT LANDSCAPE AREAS, SUCH AS A 6" CONCRETE CURB ARE REQUIRED. IF A STANDARD 6' CURB AND GUTTER ARE NOT PROVIDED FOR ALL VEHICULAR USE AREAS AND ADJACENT LANDSCAPE AREAS, COMPLY WITH ECM.
6. EACH COMPACT PARKING SPACE/AISLE WILL BE SIGNED "SMALL CAR ONLY".
7. PRIOR TO PERFORMING ANY WORK IN OR ON THE RIGHT OF WAY OF ANY CITY OR STATE ROADWAY, THE CONTRACTOR SHALL NOTIFY THE CITY/STATE TRAFFIC ENGINEER'S OFFICE. THE CONTRACTOR SHALL ERECT WARNING SIGNS AND BARRICADES TO PROTECT THE TRAVELING PUBLIC. THE SIGNING AND BARRICADING SHALL CONFORM TO THE APPROPRIATE APPLICATIONS OUTLINED IN THE MANUAL OF UNIFORM TRAFFIC CONTROL DEVICES OR AS OTHERWISE DIRECTED BY THE CITY/STATE TRAFFIC ENGINEER. IF PERMITS ARE REQUIRED TO CONDUCT THE WORK, THE CONTRACTOR SHALL SECURE THE PERMITS AND SUPPLY THEM TO THE OWNER AT NO ADDITIONAL COST. ALL FULL WIDTH LANE CLOSURES, PARTIAL LANE CLOSURES, OR CONSTRUCTION ADJACENT TO PAVEMENT, SHALL BE IDENTIFIED, SIGNED, AND BARRICADES ERECTED IN CONFORMANCE WITH THE APPLICABLE ARTICLES OF THE STANDARD SPECIFICATIONS AND THE MUNICIPALITY'S REQUIREMENTS. ALL TRAFFIC PROTECTION, BOTH ONSITE AND OFFSITE SHALL BE CONSIDERED INCIDENTAL TO THE CONTRACT.

REVISION RECORD

--

EARTHWORK NOTES AND REQUIREMENTS:

1. CONTRACTOR IS RESPONSIBLE FOR ALL MATERIALS TESTING AND CERTIFICATION, UNLESS SPECIFIED OTHERWISE BY OWNER. ALL MATERIALS TESTING SHALL BE COORDINATED WITH THE APPROPRIATE CITY INSPECTOR AND COMPLY WITH CITY STANDARD SPECIFICATIONS AND GEOTECHNICAL REPORT. TESTING SHALL BE PERFORMED BY AN APPROVED INDEPENDENT AGENCY FOR TESTING MATERIALS. OWNER SHALL APPROVE THE AGENCY NOMINATED BY THE CONTRACTOR FOR MATERIALS TESTING.
2. ALL COPIES OF MATERIALS TEST RESULTS SHALL BE SENT TO THE OWNER, ENGINEER AND ARCHITECT DIRECTLY FROM THE TESTING AGENCY.
3. IT SHALL BE THE CONTRACTOR'S RESPONSIBILITY TO SHOW, BY THE STANDARD TESTING PROCEDURES OF THE MATERIALS, THAT THE WORK CONSTRUCTED MEETS THE PROJECT REQUIREMENTS AND CITY SPECIFICATIONS.
4. DUE TO THE POTENTIAL FOR DIFFERENTIAL SOIL MOVEMENT ADJACENT TO THE BUILDING, THE CONTRACTOR SHALL ADHERE TO THE GEOTECHNICAL REPORT'S RECOMMENDATION FOR SUBGRADE PREPARATION SPECIFIC TO FLATWORK ADJACENT TO THE BUILDING. THE OWNER AND CONTRACTOR ARE ADVISED TO OBTAIN A GEOTECHNICAL ENGINEER RECOMMENDATION SPECIFIC TO FLATWORK ADJACENT TO THE BUILDING, IF NONE IS CURRENTLY EXISTING.
5. THE CONTRACTOR SHALL COMPLY WITH ALL LOCAL, STATE, AND FEDERAL EROSION CONTROL AND WATER QUALITY REQUIREMENTS.
6. A RETAINING WALL OVER 4 FEET IN HEIGHT MEASURED FROM THE BOTTOM OF THE FOOTING TO THE TOP OF THE WALL SHALL BE ENGINEERED AND REQUIRE A SEPARATE BUILDING PERMIT.
7. CONTRACTOR SHALL REMOVE EARTHEN MATERIAL, EXISTING SURFACES, AND STRUCTURES AS REQUIRED. ALL WASTE MATERIAL SHALL BE PROPERLY DISPOSED OFF-SITE AND SHALL BE INCIDENTAL TO THE CONTRACT.
8. ALL AGGREGATE BASE COURSE SHALL BE COMPACTED TO 95% STANDARD PROCTOR DENSITY MAXIMUM DRY DENSITY WITHIN 2 PERCENT OF OPTIMUM MOISTURE CONTENT.

TRENCH EXCAVATION NOTES:

1. THE CONTRACTOR IS RESPONSIBLE FOR OBTAINING AND SUBMITTING A TRENCH SAFETY PLAN, PREPARED BY A PROFESSIONAL ENGINEER IN THE STATE OF TEXAS, TO THE CITY PRIOR TO CONSTRUCTION. CONTRACTOR IS RESPONSIBLE FOR MAINTAINING TRENCH SAFETY REQUIREMENTS IN ACCORDANCE WITH CITY, STATE, AND FEDERAL REQUIREMENTS, INCLUDING OSHA, FOR ALL TRENCHES. THE CONTRACTOR SHALL KEEP TRENCHES FREE FROM WATER.
2. CONTRACTOR AND/OR CONTRACTOR'S INDEPENDENTLY RETAINED EMPLOYEE OR STRUCTURAL DESIGN / GEOTECHNICAL / SAFETY / EQUIPMENT CONSULTANT, IF ANY, SHALL REVIEW THESE PLANS AND ANY AVAILABLE GEOTECHNICAL INFORMATION AND THE ANTICIPATED INSTALLATION SITES WITHIN THE PROJECT WORK AREA IN ORDER TO IMPLEMENT CONTRACTOR'S TRENCH EXCAVATION SAFETY PROTECTION SYSTEMS, PROGRAMS, AND/OR PROCEDURES FOR THE PROJECT DESCRIBED IN THE CONTRACT DOCUMENTS. THE CONTRACTOR'S IMPLEMENTATION OF THESE SYSTEMS, PROGRAMS, AND/OR PROCEDURES SHALL PROVIDE FOR ADEQUATE TRENCH EXCAVATION SAFETY PROTECTION THAT COMPLY WITH AS A MINIMUM, OSHA STANDARDS FOR TRENCH EXCAVATIONS. SPECIFICALLY, CONTRACTOR AND/OR CONTRACTOR'S INDEPENDENTLY RETAINED EMPLOYEE OR SAFETY CONSULTANT SHALL IMPLEMENT A TRENCH SAFETY PROGRAM IN ACCORDANCE WITH OSHA STANDARDS GOVERNING THE PRESENCE AND ACTIVITIES OF INDIVIDUALS WORKING IN AND AROUND TRENCH EXCAVATION.
3. BRACING OF UTILITY POLES MAY BE REQUIRED WHEN TRENCHING OR EXCAVATING IN CLOSE PROXIMITY TO THE POLES AND IS THE RESPONSIBILITY OF THE CONTRACTOR.
4. ALL TRENCH BACKFILL SHALL BE IMPORTED GRANULAR MATERIAL UNLESS EXISTING GRANULAR MATERIALS ARE SPECIFICALLY APPROVED BY THE OWNER'S REPRESENTATIVE.

INDEMNIFICATION

THE CONTRACTOR SHALL INDEMNIFY AND HOLD HARMLESS THE OWNER, THE CITY, AND SANDLIN SERVICES, LLC. FROM AND AGAINST ALL CLAIMS, DAMAGES, LOSSES AND EXPENSES INCLUDING ATTORNEY'S FEES ARISING OUT OF OR RESULTING FROM THE PERFORMANCE OF THE CONTRACTOR'S WORK. IN ANY AND ALL CLAIMS AGAINST THE OWNER OR SANDLIN SERVICES, LLC. BY ANY EMPLOYEE OF THE CONTRACTOR OR ANYONE DIRECTLY OR INDIRECTLY EMPLOYED BY THE CONTRACTOR OR ANYONE FOR WHOSE ACTS THE CONTRACTOR MAY BE LIABLE, THE INDEMNIFICATION OBLIGATION SHALL NOT BE LIMITED IN ANY WAY BY ANY LIMITATION ON THE AMOUNT OF DAMAGES, COMPENSATION, OR BENEFITS PAYABLE BY OR FOR THE CONTRACTOR UNDER WORKER'S COMPENSATION ACTS, DISABILITY BENEFIT ACTS OR OTHER EMPLOYEE BENEFIT ACTS.

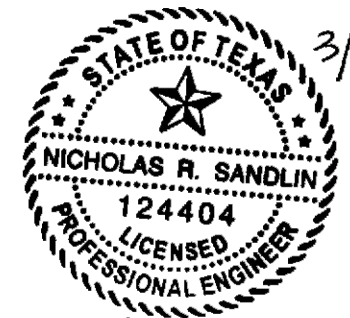

3/20/2024

Nicholas R. Sandlin

GENERAL NOTES (3 OF 4)

SHEET 4 OF 10

P.E.C. LIBERTY HILL EAPP

EXCELL FUELING SYSTEMS



TBPELS FIRM #21356
 9111 JOLLVILLE RD., STE. 212
 AUSTIN, TX 78759

BUILDING COORDINATION & CONSTRUCTION NOTES:

1. THE SCOPE OF WORK FOR THE CIVIL IMPROVEMENTS SHOWN ON THESE PLANS TERMINATES 5-FEET FROM THE BUILDING. REFERENCE THE BUILDING PLANS (E.G. ARCHITECTURAL, STRUCTURAL, MEP) FOR AREAS WITH 5-FEET OF THE BUILDING AND WITHIN THE BUILDING FOOTPRINT.
2. REFER TO ARCHITECTURAL AND STRUCTURAL PLANS FOR ALL FINAL BUILDING DIMENSIONS.
3. THE PROPOSED BUILDING FOOTPRINT(S) SHOWN IN THESE PLANS WAS PROVIDED TO SANDLIN SERVICES, LLC. BY THE PROJECT ARCHITECT AT THE TIME THESE PLANS WERE PREPARED. IT MAY NOT BE THE FINAL CORRECT VERSION BECAUSE THE BUILDING DESIGN ONGOING. THE CONTRACTOR IS SOLELY RESPONSIBLE FOR CONFIRMING THE FINAL CORRECT VERSION OF THE BUILDING FOOTPRINT WITH THE ARCHITECT AND STRUCTURAL ENGINEER PRIOR TO LAYOUT. DIMENSIONS AND/OR COORDINATES SHOWN ON THESE PLANS WERE BASED ON THE ABOVE STATED ARCHITECTURAL FOOTPRINT, AND ARE THEREFORE A PRELIMINARY LOCATION OF THE BUILDING. THE CONTRACTOR IS SOLELY RESPONSIBLE TO VERIFY WHAT PART OF THE BUILDING THE ARCHITECT'S FOOTPRINT REPRESENTS (E.G. SLAB, OUTSIDE WALL, MASONRY LEDGE, ETC....) AND TO CONFIRM ITS FINAL POSITION ON THE SITE BASED ON THE FINAL ARCHITECTURAL FOOTPRINT, CIVIL DIMENSION CONTROL PLAN, SURVEY BOUNDARY AND/OR PLAT. ANY DIFFERENCES FOUND SHALL BE REPORTED TO SANDLIN SERVICES, LLC. IMMEDIATELY.
4. ALL CONSTRUCTION AND MATERIALS SHALL BE IN ACCORDANCE WITH THESE PLANS, LOCAL JURISDICTION STANDARD DETAILS AND SPECIFICATIONS, THE FINAL GEOTECHNICAL REPORT, AND ALL ISSUED ADDENDA, AND COMMONLY ACCEPTED CONSTRUCTION STANDARDS. THE CITY SPECIFICATIONS SHALL GOVERN WHERE OTHER SPECIFICATIONS DO NOT EXIST. IN CASE OF CONFLICTING SPECIFICATIONS OR DETAILS, THE MORE SPECIFICATION AND DETAILS SHALL BE FOLLOWED.
5. THE CONTRACTOR SHALL FURNISH ALL MATERIAL AND LABOR TO CONSTRUCT THE FACILITY AS SHOWN AND DESCRIBED IN THE CONSTRUCTION DOCUMENTS IN ACCORDANCE WITH ALL APPROPRIATE AUTHORITIES' SPECIFICATIONS AND REQUIREMENTS.
6. THE EXISTING CONDITIONS SHOWN ON THESE PLANS WERE PROVIDED BY THE TOPOGRAPHIC SURVEY PREPARED BY THE PROJECT SURVEYOR, AND ARE BASED ON THE BENCHMARKS SHOWN. THE CONTRACTOR SHALL REFERENCE THE SAME BENCHMARKS. THE CONTRACTOR SHALL REVIEW AND VERIFY THE EXISTING TOPOGRAPHIC SURVEY SHOWN ON THE PLANS REPRESENTS THE EXISTING FIELD CONDITIONS PRIOR TO CONSTRUCTION, AND SHALL REPORT ANY DISCREPANCIES FOUND TO THE OWNER AND ENGINEER IMMEDIATELY.
7. ALL CONSTRUCTION SURVEYING AND STAKING SHALL BE PROVIDED BY THE GENERAL CONTRACTOR.
8. CONTRACTOR SHALL VERIFY HORIZONTAL AND VERTICAL CONTROL, INCLUDING BENCHMARKS, PRIOR TO COMMENCING CONSTRUCTION OR STAKING OF IMPROVEMENTS.
9. PRIOR TO COMMENCEMENT OF CONSTRUCTION, THE CONTRACTOR SHALL VERIFY ALL DIMENSIONS AND CONDITIONS AFFECTING THEIR WORK WITH THE ACTUAL CONDITION AT THE PROJECT SITE. IN ADDITION, THE CONTRACTOR MUST VERIFY THE ENGINEER'S LINE AND GRADE STAKES. IF THERE ARE ANY DISCREPANCIES FROM WHAT IS SHOWN ON THE CONSTRUCTION PLANS, THE CONTRACTOR MUST IMMEDIATELY PROVIDE THE INFORMATION TO THE ENGINEER BEFORE DOING ANY WORK, OTHERWISE, THE CONTRACTOR ASSUMES FULL RESPONSIBILITY. IN THE EVENT OF A DISAGREEMENT BETWEEN THE CONSTRUCTION PLANS, STANDARD SPECIFICATIONS, AND/OR DETAILS. THE CONTRACTOR SHALL SECURE WRITTEN INSTRUCTIONS FROM THE ENGINEER PRIOR TO PROCEEDING WITH ANY PART OF THE WORK AFFECTED BY OMISSIONS OR DISCREPANCIES. IF THE CONTRACTOR FAILS TO SECURE WRITTEN INSTRUCTIONS FROM THE ENGINEER, THE CONTRACTOR WILL BE CONSIDERED TO HAVE PROCEEDED AT THEIR OWN RISK AND EXPENSE. IN THE EVENT OF ANY DOUBT OR QUESTION ARISING WITH RESPECT TO SPECIFICATIONS, THE DECISION OF THE ENGINEER SHALL BE FINAL.
10. THE CONTRACTOR SHALL REVIEW ALL DIMENSIONS, ELEVATIONS, AND FIELD CONDITIONS THAT MAY AFFECT CONSTRUCTION. ANY DISCREPANCIES ON THE DRAWINGS SHALL BE BROUGHT TO THE ATTENTION OF THE ARCHITECT AND ENGINEER IMMEDIATELY.
11. NO FIELD CHANGES OR DEVIATION FROM DESIGN ARE TO BE MADE WITHOUT PRIOR APPROVAL OF THE ARCHITECT, ENGINEER, OWNER, AND IF APPLICABLE THE CITY,
12. THE CONTRACTOR SHALL THOROUGHLY CHECK COORDINATION OF CIVIL, LANDSCAPE, MEP, ARCHITECTURAL, AND OTHER PLANS, PRIOR TO COMMENCING CONSTRUCTION AND NOTIFY OWNER/ENGINEER OF ANY DISCREPANCY PRIOR TO COMMENCING WITH CONSTRUCTION.
13. THE CONTRACTOR SHALL BE RESPONSIBLE TO OBTAIN ALL REQUIRED CONSTRUCTION PERMITS, APPROVALS, AND BONDS PRIOR TO CONSTRUCTION.
14. THE CONTRACTOR SHALL HAVE AVAILABLE AT THE JOB SITE AT ALL TIMES A COPY OF THE CONTRACT DOCUMENTS INCLUDING PLANS, GEOTECHNICAL REPORT AND ADDENDA, PROJECT AND CITY SPECIFICATIONS, AND SPECIAL CONDITIONS, COPIES OF ANY REQUIRED CONSTRUCTION PERMITS, EROSION CONTROL PLANS, SWPPP, AND INSPECTION REPORTS.
15. THE CONTRACTOR SHALL KEEP A NEAT AND ACCURATE RECORD OF CONSTRUCTION, INCLUDING ANY DEVIATIONS OR VARIANCES FROM THE PLANS.
16. THE CONTRACTOR SHALL BE RESPONSIBLE FOR PROVIDING AS-BUILT PLANS TO THE ENGINEER AND CITY IDENTIFYING ALL DEVIATIONS AND VARIATIONS FROM THESE PLANS MADE DURING CONSTRUCTION.
17. THE CONTRACTOR TO COORDINATE WITH PROJECT ARBORIST TO TRIM TREES TO ENSURE VISIBILITY NEAR PARKING AREAS.
18. ALL DIMENSIONS ARE TO FACE OF CURB UNLESS OTHERWISE NOTED.
19. ALL RADII TO BE 2' UNLESS OTHERWISE NOTED.
20. ALL ON-SITE UTILITIES SHALL BE LOCATED UNDERGROUND UNLESS REQUIRED BY THE UTILITY TO BE OTHERWISE LOCATED.
21. SIDEWALKS CITY PARK ROAD ARE REQUIRED TO BE CONSTRUCTED BY THE PROPERTY OWNER AFTER THE ABUTTING ROADWAY IS IMPROVED AND CONCRETE CURBS ARE IN PLACE.
22. WHEN CONCRETE IS PLACED ABUTTING STRUCTURES, FOUNDATIONS OR EXISTING SIDEWALKS, A BOND BREAKER CONSISTING OF 1" PJF AND ELASTOMERIC SEALANT SHALL BE USED FULL DEPTH UNTIL OTHERWISE NOTED.
23. SIDEWALK RAMPS FOR ADA SHALL BE IN ACCORDANCE WITH THE STANDARD SPECIFICATIONS.
24. CONSTRUCTION STAKING, LAYOUT, AND GRADING SHALL BE THE RESPONSIBILITY OF THE CONTRACTOR USING THE BASIC TOPOGRAPHIC SURVEY CONTROLS. CONTRACTOR SHALL VERIFY SURVEY CONTROLS PRIOR TO BEGINNING CONSTRUCTION. ANY DISCREPANCIES IN THE SURVEY CONTROLS SHALL BE REPORTED TO THE OWNER AND ENGINEER PRIOR TO CONSTRUCTION. ANY ADDITIONAL SURVEY CONTROLS REQUIRED FOR CONSTRUCTION SHALL BE THE RESPONSIBILITY OF THE CONTRACTOR.
25. ANY SIDEWALKS, FENCES, AND OTHER ITEMS NOT SHOWN TO BE REMOVED, BUT DAMAGED DURING CONSTRUCTION, SHALL BE REPAIRED BY THE CONTRACTOR AT NO COST TO THE OWNER.

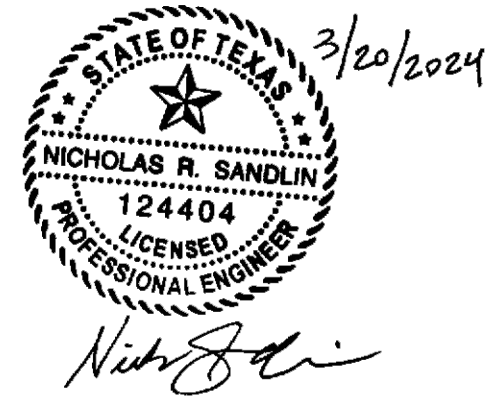

REVISION RECORD

GENERAL NOTES (4 OF 4)

SHEET 5 OF 10

P.E.C. LIBERTY HILL EAPP

EXCELL FUELING SYSTEMS

ENGINEERING | CONSULTING
SANDLIN
SERVICES, LLC

TBPELS FIRM #21356
9111 JOLLVILLE RD., STE. 212
AUSTIN, TX 78759

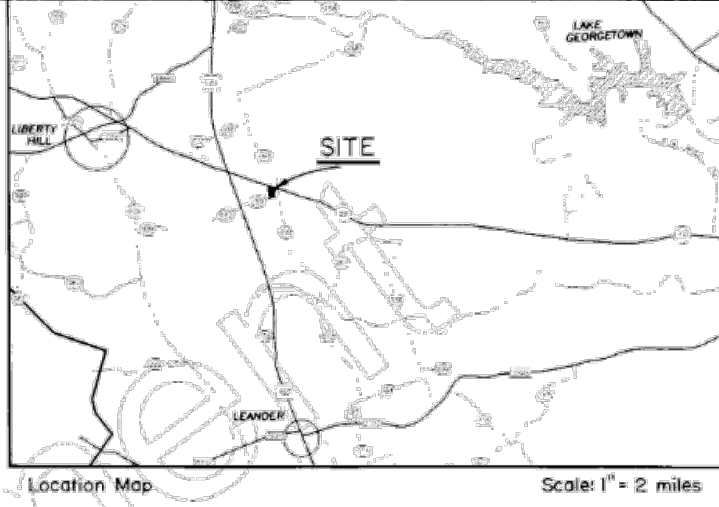
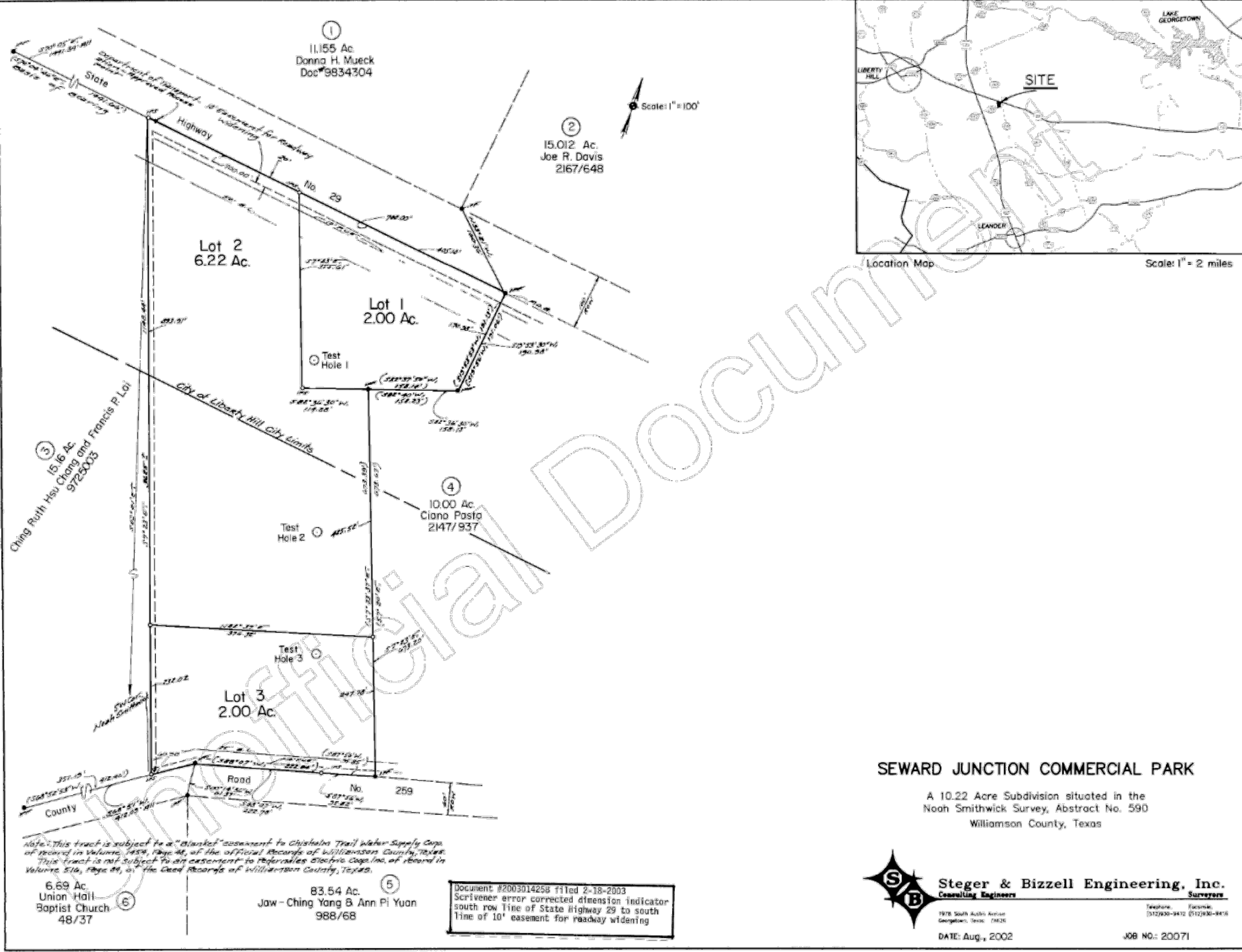

STATE OF TEXAS 3/20/2024
 NICHOLAS R. SANDLIN
 124404
 LICENSED PROFESSIONAL ENGINEER
Nicholas R. Sandlin

SEWARD JUNCTION COMMERCIAL PARK

A 10.22 Acre Subdivision situated in the
 Noah Smithwick Survey, Abstract No. 590
 Williamson County, Texas

Steger & Bizzell Engineering, Inc.
 Consulting Engineers Surveyors
 1978 South Austin Avenue
 Georgetown, Texas 78626
 Telephone: (512) 930-9410 Facsimile: (512) 930-9416
 DATE: Aug., 2002 JOB NO.: 20071

Document #2003014258 filed 2-18-2003
 Scrivener error corrected dimension indicator
 south row line of State Highway 29 to south
 line of 10' easement for roadway widening

REVISION RECORD

--	--

FINAL PLAT (1 OF 2)
 SHEET 6 OF 10
 P.E.C. LIBERTY HILL EAPP
 EXCELL FUELING SYSTEMS

ENGINEERING | CONSULTING
SANDLIN
 SERVICES, LLC
 TBPELS FIRM #21356
 9111 JOLLVILLE RD., STE. 212
 AUSTIN, TX 78759

CABINET W

SLIDE # 319

PERIMETER LEGAL DESCRIPTION

BEING 10.22 acres of land, situated in the Noah Smithwick Survey, Abstract No. 590, in Williamson County, Texas, said land being that certain tract of land, called 10.22 acres, as conveyed to IDM Supply by deed recorded as Document No. 2002-046738...

BEGINNING at an iron pin found on the south line of State Highway No. 29, marking the Northeast corner of the above-referenced 10.22 acre IDM Supply tract, being the Northwest corner that certain tract of land, called 10.00 acres, as conveyed to Ciano Pasta by deed recorded as Document No. 2000933370...

THENCE, along the east line of the said 10.22 acre IDM Supply tract, being the west line of the said Ciano Pasta tract, as follows: S 19° 53' 30" W, 190.95 feet to an iron pin found; S 82° 36' 30" W, 158.13 feet to an iron pin found and S 7° 23' E, 673.30 feet to an iron pin found on the north line of County Road No. 255, marking the Southwest corner of the said 10.22 acre IDM Supply tract, being the Southwest corner of the said Ciano Pasta tract, for the Southeast corner hereof;

THENCE, along the said north line of County Road No. 255, as follows: S 87° 56' W, 95.82 feet to an iron pin found; S 88° 07' W, 222.75 feet to an iron pin found and S 68° 51' W, 60.90 feet to an iron pin found for the Southwest corner of the said 10.22 acre IDM Supply tract, being the Southwest corner of the remainder of that certain tract of land, called 25.38 acres, as conveyed to Ching Ruth Hsu Chang and Francis P. Lal, Custodian for Nancy N. Lal, a Minor under the Texas Uniform Gifts to Minors Act by deed recorded as Document No. 9725003 of the Official Records of Williamson County, Texas, for the Southwest corner hereof;

THENCE, N 7° 23' W, 1,148.44 feet to an iron pin found on the said south line of State Highway No. 29, for the Northwest corner of the said 10.22 acre IDM Supply tract, being the Northwest corner of the said remainder of the 25.38 acre tract, for the Northwest corner hereof;

THENCE, along the said south line of State Highway No. 29, S 70° 05' E, 700.00 feet to the Place of BEGINNING and containing 10.22 acres of land.

STATE OF TEXAS KNOW ALL MEN BY THESE PRESENTS COUNTY OF WILLIAMSON

I, Don H. Bizzell, Registered Professional Land Surveyor, in the State of Texas, do hereby certify that this plat is true and correctly made from an actual survey on the ground of the property legally described hereon, and that there are no apparent discrepancies, conflicts, overlapping of improvements, visible utility lines or roads in place, except as shown on the accompanying plat, and that the perimeter field notes hereon have a mathematical closure in compliance with standards as set out in the "Manual of Practice" of the Texas Society of Professional Surveyors, to the best of my knowledge and belief.

TO CERTIFY WHICH, WITNESS my hand and seal at Georgetown, Williamson County, Texas, this the 26th day of August, 2002, A.D.

Don H. Bizzell Registered Professional Land Surveyor, No. 2218 State of Texas



Based upon the above representations of the engineer or surveyor whose seal is affixed hereto, and after a review of the plat as represented by the said engineer or surveyor, I find that this plat complies with the requirements of Edwards Aquifer Regulations for Williamson County, the Williamson County Flood Plain Regulations and Williamson County On-Site Sewerage Facility Regulations. This certification is made solely upon such representations and should not be relied upon for verification of the facts alleged. The Williamson County & Cities Health District and Williamson County disclaims any responsibility to any member of the public for independent verification of the representation, factual or otherwise, contained in this plat and the documents associated with it.

Paula Pinto Director of Environmental Services 10/17/02 Date

City of Liberty Hill, Texas Planning and Zoning Commission This plat has been presented to the Planning and Zoning Commission of the City of Liberty Hill, Texas for review, and has been approved.

Elizabeth Stubbfield Chairperson 10/1/02 Date

City of Liberty Hill, Texas This plat has been presented to the City Council of the City of Liberty Hill, Texas for review, and has been approved.

Bob McEachern Mayor 10/11/02 Date

STATE OF TEXAS KNOW ALL MEN BY THESE PRESENTS COUNTY OF WILLIAMSON

I, Don H. Bizzell, Registered Professional Engineer, do hereby certify that this subdivision is not the Edwards Aquifer Recharge Zone. An approved Water Pollution Abatement Plan is not required by the Texas Natural Resource Conservation Commission. No lot within this subdivision is encroached by any Special Flood Hazard Areas inundated by 100-Year Flood as identified by the U.S. Federal Emergency Management Agency Flood Insurance Rate Map, Map No. 48491C0100 C, effective date September 27, 1991.

The engineering work for the roads and drainage (including driveway drain pipes) within the subdivision have been completed in compliance with the Williamson County Subdivision Regulations (including the Engineering Guidelines incorporated as Appendix B) and all generally accepted engineering standards.

TO CERTIFY WHICH, WITNESS my hand and seal at Georgetown, Williamson County, Texas, this the 26th day of August, 2002, A.D.

Don H. Bizzell Professional Engineer, No. 28762 State of Texas



STATE OF TEXAS KNOW ALL MEN BY THESE PRESENTS COUNTY OF WILLIAMSON

I, David S. Morgan, President of IDM Supply, owner of the certain tracts of land shown hereon and described in a deed recorded as Document No. 2002-046738, of the Official Records of Williamson County, Texas, do hereby join, approve, and consent to all dedications and plat note requirements shown hereon. I do hereby approve the recordation of this subdivision plat and dedicate to the public use forever any easements and roads that are shown hereon. This subdivision is to be known as "Seward Junction Commercial Park". I hereby acknowledge that I am the sole owner of this property and do hereby state that there are no lienholders or any unpaid debt for which this property represents collateral on any loan. It is also understood that it is the responsibility of the owner, not the County, to assure compliance with the applicable state, federal, and local laws and regulations relating to the environment, including, but not limited to the Endangered Species Act, State Aquifer Regulations, and Municipal Watershed Ordinances.

David S. Morgan 10-10-02 Date IDM Supply David S. Morgan, President 300 CR 258 Liberty Hill, Texas 76042

Before me, the undersigned authority, on this day personally appeared David S. Morgan, known by me to be the person whose name is subscribed to the foregoing instrument, it has been acknowledged to me that he/she executed the foregoing instrument as the owner of the property described herein.

Notary Public in and for the State of Texas K. J. STEVENS Notary Public State of Texas My Commission Expires NOVEMBER 04, 2006

Road name and address assignment verified this the 4th day of September, 2002.

Williamson County Address Coordinator

STATE OF TEXAS KNOW ALL MEN BY THESE PRESENTS COUNTY OF WILLIAMSON

In approving this plat by the Commissioners' Court of Williamson County, Texas, it is understood that the building of all street, roads, and other public thoroughfares and any bridges or culverts necessary to be constructed or placed is the responsibility of the owners of the tract of land covered by this plat in accordance with the plans and specifications prescribed by the Commissioners' Court of Williamson County, Texas. Said Commissioners' Court assumes no obligation to build any of the streets, roads, or other public thoroughfares shown on this plat or of construction of any of the bridges or drainage improvements in connection therewith. The County will assume no responsibility for drainage ways or easements in the subdivision, other than those draining or protecting the road systems and streets.

The County assumes no responsibility for the accuracy of representations by other parties in this plat. Flood plain data, in particular, may change depending on subsequent development. It is further understood that the owners of the tract of land covered by this plat must install at their own expense all traffic control devices and signage that may be required before the streets in the subdivision have finally been accepted for maintenance.

I, John C. Doerfler, County Judge of Williamson County, Texas, do hereby certify that this map or plat, with field notes hereon, that a subdivision having been fully presented to the Commissioners' Court of Williamson County, Texas, and by the said Court duly considered, were on this day approved and plat is authorized to be registered and recorded in the proper records of the County Clerk of Williamson County, Texas.

John C. Doerfler 10-6-02 10-29-02 Date

GENERAL NOTES:

- 1. Total Acres: 10.22
2. Number of lots: 3
3. Number of blocks: 1
4. Area of smallest lot: 2.00 Acres
5. Proposed use: Commercial business park
6. In order to promote drainage away from a structure, the slab elevation should be built at least one foot above the surrounding ground, and the ground should be graded away from the structure at a slope of 1/2" per foot for a distance of at least 10 feet.
7. Each lot will be served by an on-site wastewater system. Water will be provided by Chisholm Trail Water Supply Corporation.
8. This tract is not located in the Edwards Aquifer Recharge Zone.
9. No structure or land on this plat shall hereafter be located or altered without first submitting a CERTIFICATE OF COMPLIANCE Application Form to the Williamson County Flood Plain Administrator.
10. All dwellings, trailers, or mobile homes placed on subdivision lots or ranchettes must be connected to septic tanks or disposal facilities meeting the specifications and conditions of the state Department of Health and the private sewage facility regulations applicable to Williamson County as of the date of application.
11. OWNER: IDM Supply David S. Morgan 350 CR 258 Liberty Hill, Texas 76042 512-515-5573
12. ENGINEER/SURVEYOR: Don H. Bizzell, P.E., R.P.L.S. Steger & Bizzell Engineering, Inc. 1978 S. Austin Avenue Georgetown, Texas 78626 512-930-9412
13. Right-of-way easements for widening roadways or improving drainage shall be maintained by the landowner until a road or drainage improvements are actually constructed on the property. The County has the right at any time to take possession of any road widening easement for the construction, improvement or maintenance of the adjacent road. The landowner assumes all risks associated with improvements located in the right-of-way of road widening easements. By placing anything in the right-of-way or road widening easements, the landowner indemnifies and holds the County, its officers, and employees harmless from any liability owing to property defects or negligence not attributable to them and acknowledges that the improvements may be removed by the County and that the owner of the improvement will be responsible for the relocation and/or replacement of the improvement.
14. All public roadways and easements as shown on this plat are free of liens.
15. There are no new roadways proposed for this subdivision.
16. All lots shall use a culvert pipe, with a minimum opening size of 18".
17. Positive Drainage occurs throughout the entire tract. Improvements will be made if drainage problems become apparent.
18. TxDOT will approve driveways on Hwy 29.

STATE OF TEXAS KNOW ALL MEN BY THESE PRESENTS COUNTY OF WILLIAMSON

I, Nancy Rister, Clerk of the County Court of said County, do hereby certify that the foregoing instrument in writing, with its certificate of authentication was filed for record in my office on the day of 12 November, 2002, A.D., at 3:00 o'clock, P.M., and duly recorded this the 13 day of November, 2002, A.D., at 10:23 o'clock, A.M., in the Flat Records of said County in Cabinet W, Slide 318, 319.

TO CERTIFY WHICH, WITNESS my hand and seal at the County Court of said County, at my office in Georgetown, Texas, the date last shown above written.

Nancy Rister, Clerk County Court of Williamson County, Texas

By: Lizzie Hamer Notary Public State of Texas My Commission Expires NOVEMBER 04, 2006

SEWARD JUNCTION COMMERCIAL PARK

A 10.22 Acre Subdivision situated in the Noah Smithwick Survey, Abstract No. 590 Williamson County, Texas

Steger & Bizzell Engineering, Inc. Consulting Engineers Surveyors 1978 South Austin Avenue Georgetown, Texas 78626 Telephone: 512-930-9412 Facsimile: 512-930-9412 Job No. 20071 20071-plot.dwg Sheet 2 of 2

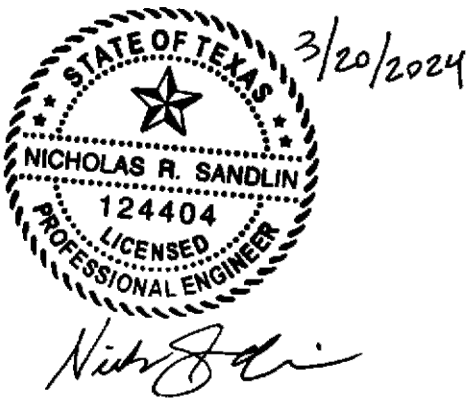

Nick Sandlin

PHOTOGRAPHIC MYLAR

REVISION RECORD

FINAL PLAT (2 OF 2) SHEET 7 OF 10 P.E.C. LIBERTY HILL EAPP EXCELL FUELING SYSTEMS

SANDLIN ENGINEERING CONSULTING SERVICES, LLC TBPELS FIRM #21356 9111 JOLLVILLE RD., STE. 212 AUSTIN, TX 78759

6.22 ACRES
 LOT 2 OF SEWARD JUNCTION
 COMMERCIAL PARK SUBDIVISION

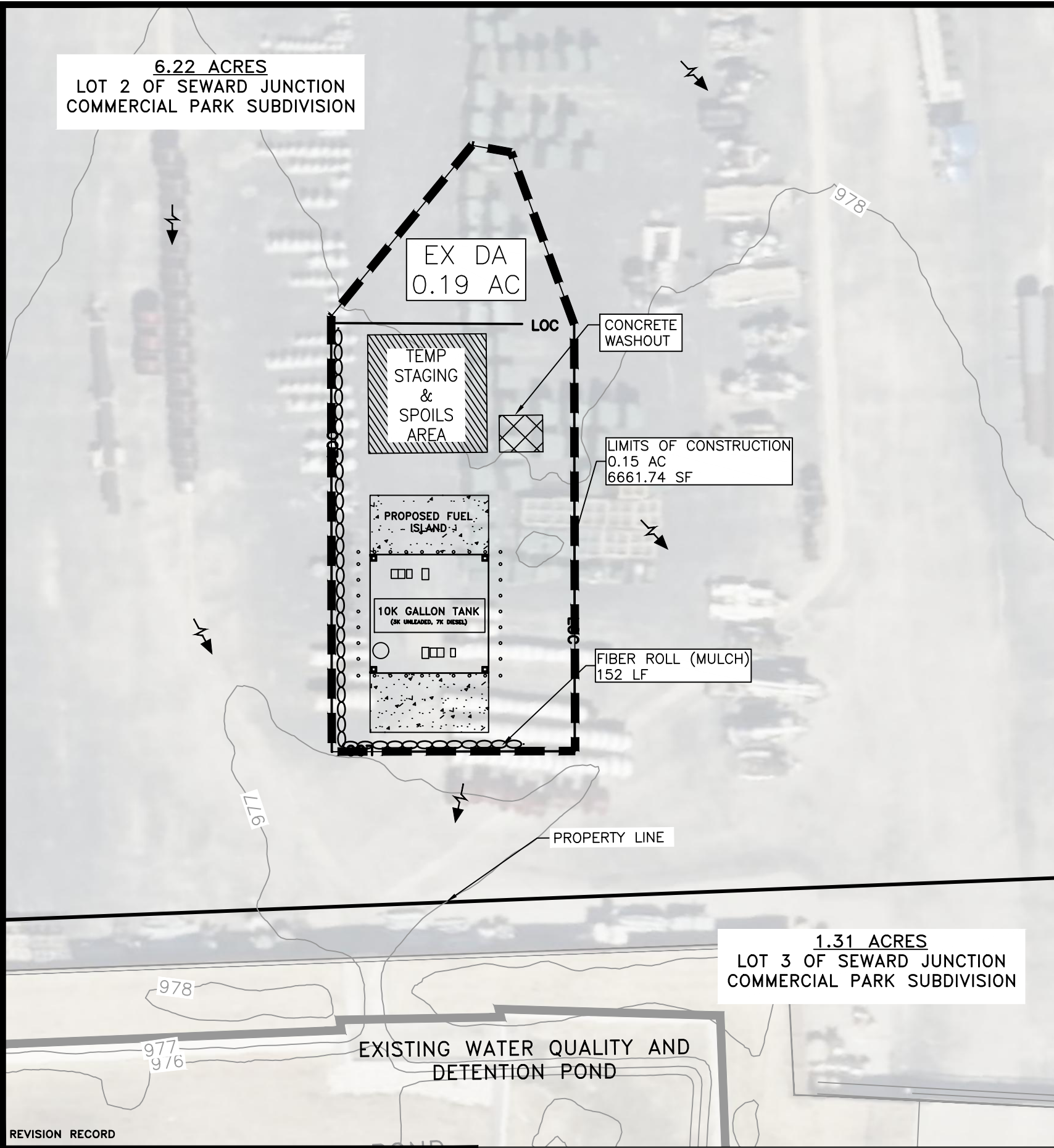

1.31 ACRES
 LOT 3 OF SEWARD JUNCTION
 COMMERCIAL PARK SUBDIVISION

REVISION RECORD

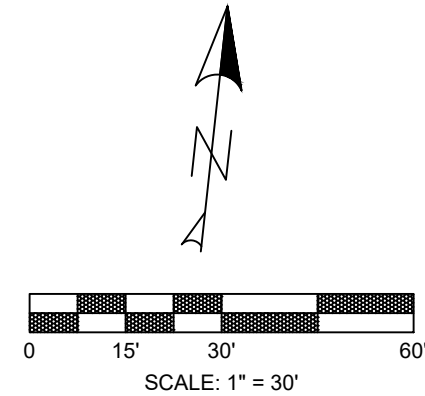

IF DRAWING BAR DOES NOT MEASURE 2"
 THIS PRINT IS NOT TO SCALE

NOTES:

1. THIS PROJECT IS SUBMITTED WITHOUT PHASING.
2. ALL EXISTING IMPERVIOUS COVER AND DRAINAGE PATTERNS WILL REMAIN UNCHANGED POST-DEVELOPMENT.
3. CONTRACTOR TO CUT AND REMOVE CONCRETE AS NECESSARY TO REMOVE ALL EXISTING PIPING. REFER TO PLANS BY OTHERS FOR EXACT LOCATION OF DISPENSERS AND PIPING.
4. ALL REQUIRED NOTICES AND PERMITS MUST BE PLACED IN A HIGHLY VISIBLE LOCATION ONSITE BEFORE THE COMMENCEMENT OF CONSTRUCTION.
5. ALL EROSION AND SEDIMENTATION CONTROLS (ESC) MUST BE INSTALLED PRIOR TO ANY DISTURBANCE TO THE PROJECT SITE.
6. ALL ESC USED ONSITE MUST BE REGULARLY MONITORED AND MAINTAINED AS NEEDED.
7. THE STABILIZED CONSTRUCTION ENTRANCE SHALL BE MAINTAINED IN A CONDITION THAT PREVENTS TRACKING ONTO THE PUBLIC ROADWAY ON AN ONGOING/REGULAR BASIS. MUD AND OR DIRT TRACKED INTO THE ROADWAY MUST BE IMMEDIATELY REMOVED UPON DISCOVERY.
8. INLET PROTECTION SHALL BE INSTALLED IMMEDIATELY UPON INLET INSTALLATION.
9. INITIATE TEMPORARY STABILIZATION WHEN CONSTRUCTION CEASES IN A DISTURBED AREA FOR 14 DAYS.
10. INITIATE PERMANENT STABILIZATION IMMEDIATELY ONCE WORK HAS CEASED AND FINAL GRADE HAS BEEN ACHIEVED.
11. ALL DISTURBED/BARE AREAS WILL REQUIRE PERMANENT STABILIZATION BEFORE FINAL ACCEPTANCE CAN BE ACHIEVED. AVOID DISTURBING AREAS OF THE PROJECT THAT ARE NOT NECESSARY FOR CONSTRUCTION.
12. TEMPORARY ESC'S SHALL REMAIN IN PLACE IN ALL DISTURBED AREAS UNTIL ADEQUATE STABILIZATION HAS BEEN ACHIEVED.
13. THE TECHNICAL SPECS OF ESC DEVICES AND BEST MANAGEMENT PRACTICES (BMP) MEET OR EXCEED THE CITY OF AUSTIN ENVIRONMENTAL CRITERIA MANUAL.
14. PER PLANS BY OTHERS, EXISTING WATER QUALITY AND DETENTION POND HAS CAPACITY FOR AND WILL TREAT RUNOFF DURING CONSTRUCTION AND IN THE PROPOSED CONDITION.
15. NO INCREASED RUNOFF OR TSS WILL RESULT FROM THIS FUEL ISLAND AND TANK CONSTRUCTION.
16. IMPERVIOUS COVER PERCENTAGE ON-SITE WILL NOT INCREASE POST-DEVELOPMENT.

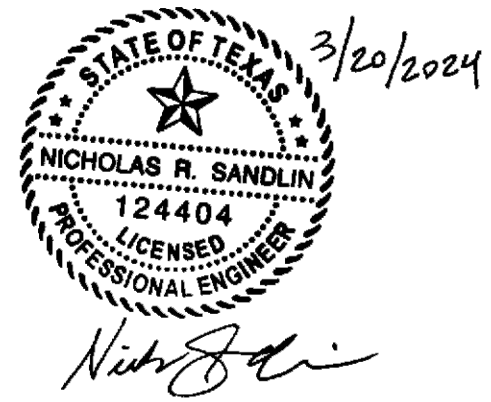

LEGEND

- PROPOSED PROPERTY/PROJECT BOUNDARY LINE
 - EXISTING R.O.W./PROPERTY LINE
 - EXISTING EASEMENT LINE
 - PROPOSED CURB & GUTTER LIMITS OF CONSTRUCTION
 - FIBER ROLL (MULCH)
 - STAGING & TEMPORARY SPOILS AREA
 - STABILIZED CONSTRUCTION ENTRANCE
 - CONCRETE WASHOUT
- NOTE: ADDITIONAL EROSION CONTROL MEASURES MAY BE REQUIRED BY INSPECTOR AT TIME OF CONSTRUCTION.
- DRAINAGE AREA BOUNDARY
 - DRAINAGE AREA DESIGNATION AND AREA DRAINED
 - FLOW ARROW

EROSION CONTROL AND DRAINAGE PLAN	<p>SANDLIN SERVICES, LLC</p> <p>TBPELS FIRM #21356 9111 JOLLVILLE RD., STE. 212 AUSTIN, TX 78759</p>
SHEET 8 OF 10	
P.E.C. LIBERTY HILL EAPP	
EXCELL FUELING SYSTEMS	

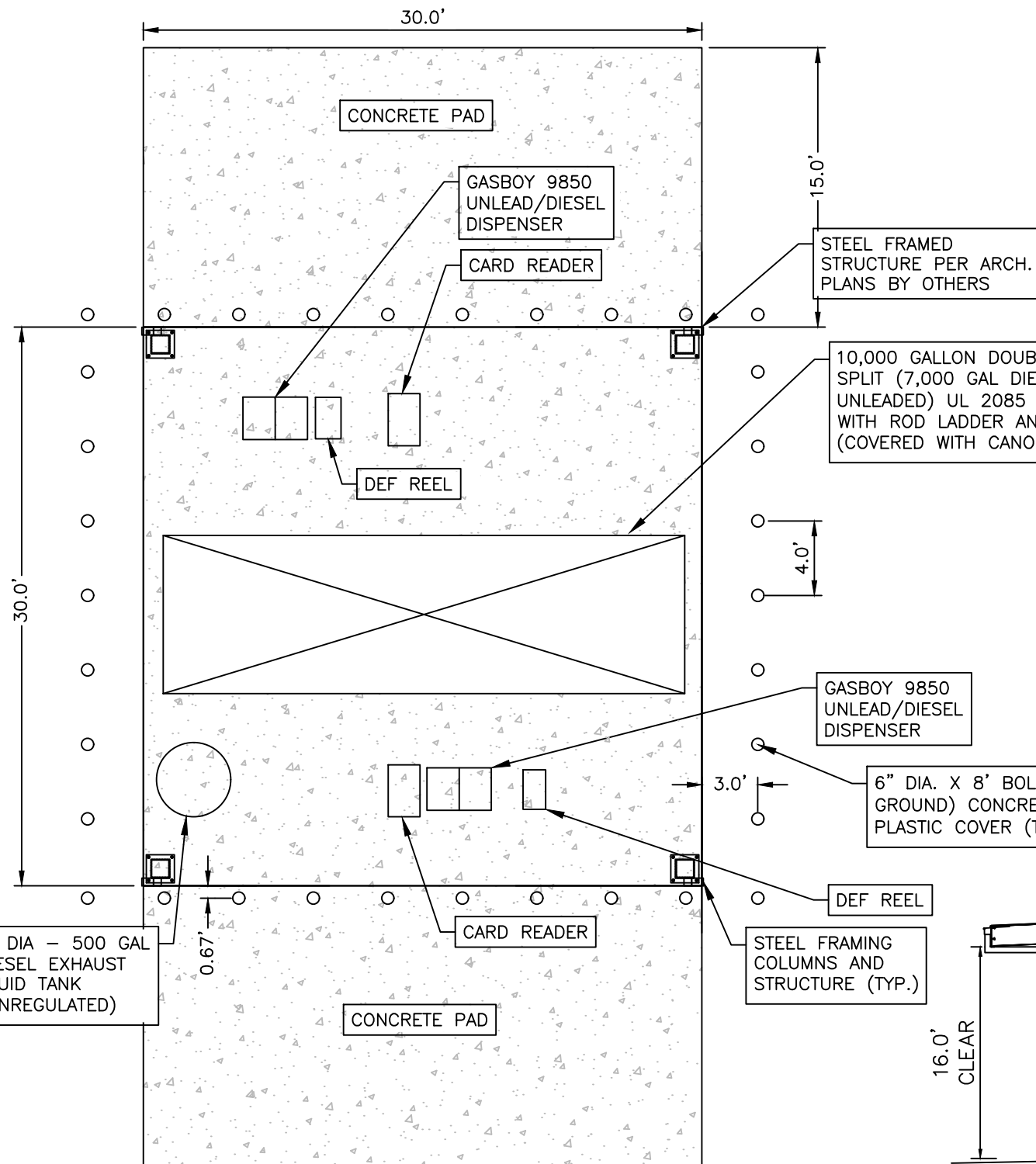

FUEL ISLAND PLAN
(N.T.S.)

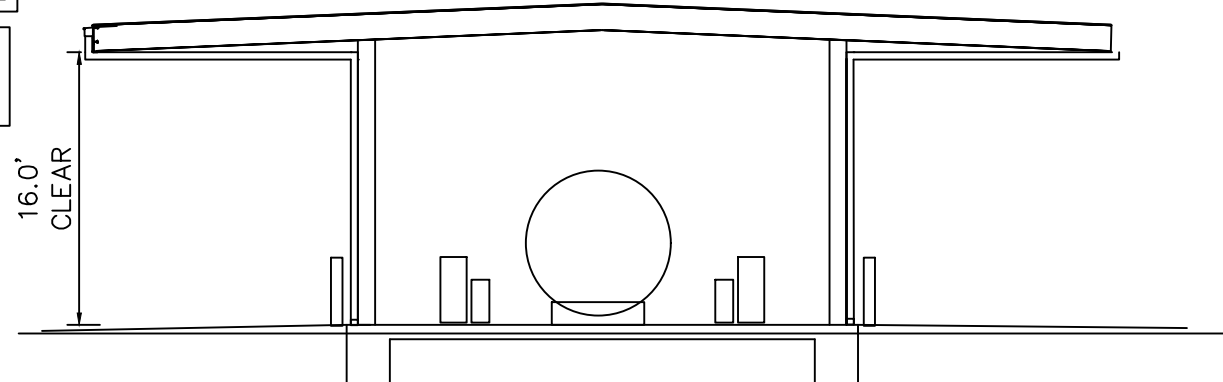

FUEL ISLAND ELEVATION
(N.T.S.)

NOTES

1. ALL PROPERTY BOUNDARIES ARE APPROXIMATE.
2. ABOVE GROUND STORAGE TANK SIZE AND SPECIFICATION TO BE PER AST APPLICATION TO TCEQ.
3. TANK LOCATION AND SIZE IS ESTIMATED AND WILL BE FIELD VERIFIED.
4. ALL TANKS SHOWN ARE DOUBLE WALLED AND THEREFORE HAVE THEIR OWN CONTAINMENT.
5. SEE ARCHITECTURAL PLANS FOR CANOPY DETAILS AND CONFIRMATION OF FUEL ISLAND DATA.

SEE PRODUCT DESCRIPTIONS FOR DETAIL, CONTAINMENT AND PROFILES

FUEL ISLAND SCHEDULE OF WORK

SUPPLY AND INSTALL THE FOLLOWING:

1. (1) 10,000 GALLON DOUBLE WALL TANK – SPLIT 10/3 UL 2085 FIREGUARD TANK WITH ROD LADDER AND E-VENTS.
2. (2) 20-GALLON REMOTE SPILL BASINS WITH 3" FILL PIPING. 3" BALL VALVES AND 3" QUICK FILL CONNECTIONS.
3. (2) 2" X 3" OVERFILL DEVICES SET AT 90%.
4. (2) DEF BLUE BOXES WITH PULSE OUTPUT WITH EXTERNAL FILTERS AND 5-MINUTE TIMERS.
5. (3) CENTERON CELL MONITORS WITH 500 CALL BLOCK.
6. FRANKLIN DEF NOZZLE AND HOSE.
7. (1) FUELMASTER 6-HOSE FMS WITH NETWORK CAPABLE.
8. ALL FITTINGS, HOSES AND NECESSARY INFRASTRUCTURE TO SUPPORT FUEL EQUIPMENT INSTALL AND OPERATION.

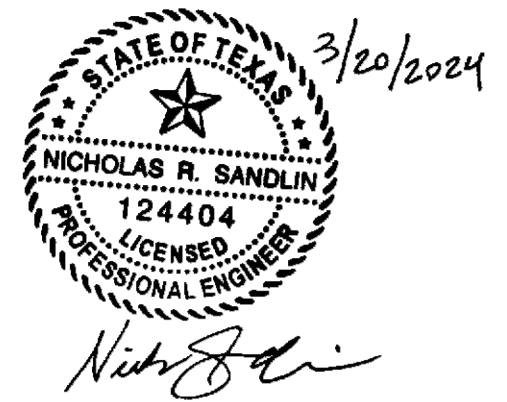

PROPERTY KEY MAP

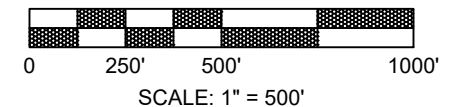

IF DRAWING BAR DOES NOT MEASURE 2" THIS PRINT IS NOT TO SCALE

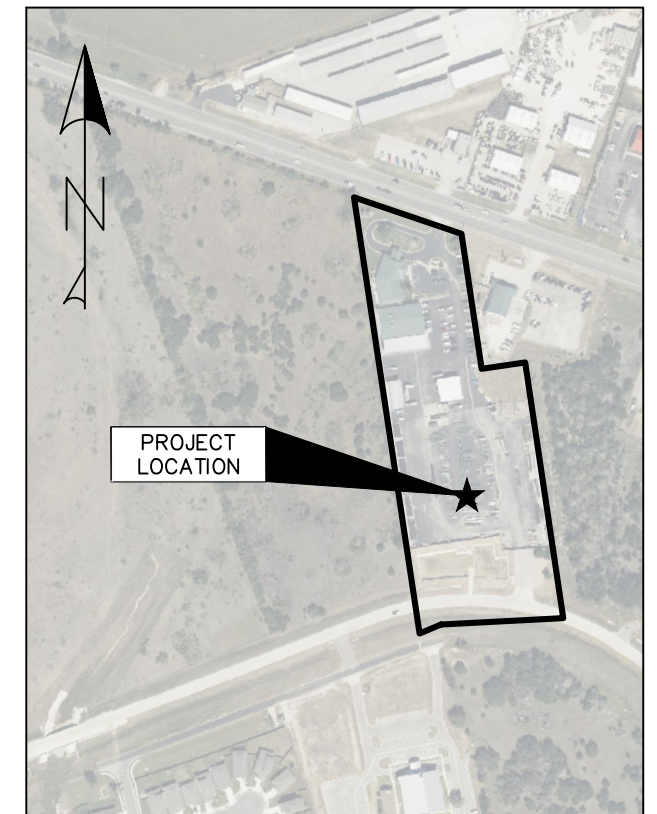

REVISION RECORD

AST TANK LAYOUT PLAN

SHEET 9 OF 10

P.E.C. LIBERTY HILL EAPP

EXCELL FUELING SYSTEMS

SANDLIN
SERVICES, LLC

TPELS FIRM #21356
9111 JOLLVILLE RD., STE. 212
AUSTIN, TX 78759

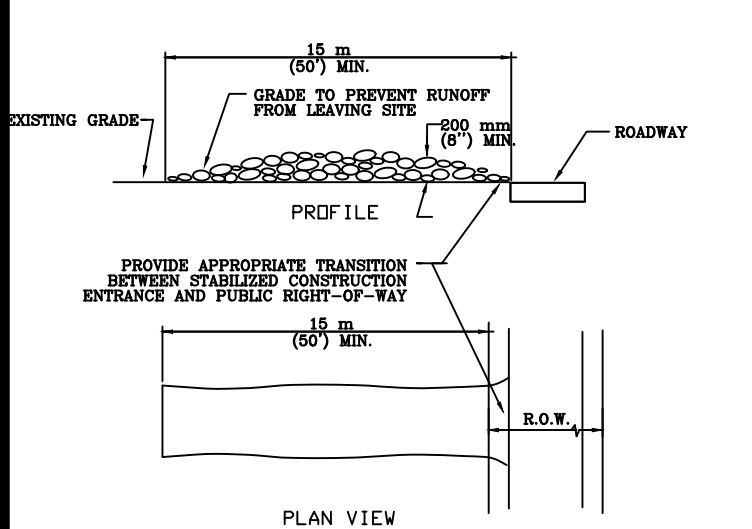
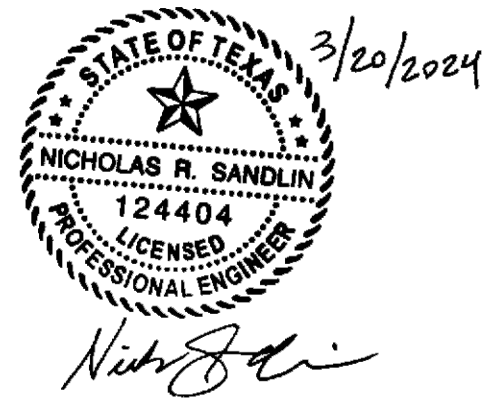

- NOTES:**
1. STONE SIZE: 75-125 mm (3-5") OPEN GRADED ROCK.
 2. LENGTH: AS EFFECTIVE BUT NOT LESS THAN 15 m (50').
 3. THICKNESS: NOT LESS THAN 200 mm (8").
 4. WIDTH: NOT LESS THAN FULL WIDTH OF ALL POINTS OF INGRESS/EGRESS.
 5. WASHING: WHEN NECESSARY, VEHICLE WHEELS SHALL BE CLEANED TO REMOVE SEDIMENT PRIOR TO ENTRANCE ONTO PUBLIC ROADWAY. WHEN WASHING IS REQUIRED, IT SHALL BE DONE ON AN AREA STABILIZED WITH CRUSHED STONE AND DRAINS INTO AN APPROVED TRAP OR SEDIMENT BASIN. ALL SEDIMENT SHALL BE PREVENTED FROM ENTERING ANY STORM DRAIN, DITCH OR WATERCOURSE USING APPROVED METHODS.
 6. MAINTENANCE: THE ENTRANCE SHALL BE MAINTAINED IN A CONDITION THAT WILL PREVENT TRACKING OR FLOWING OF SEDIMENT ONTO PUBLIC ROADWAY. THIS MAY REQUIRE PERIODIC TOP DRESSING WITH ADDITIONAL STONE AS CONDITIONS DEMAND, AS WELL AS REPAIR AND CLEAN OUT OF ANY MEASURE DEVICES USED TO TRAP SEDIMENT. ALL SEDIMENTS THAT IS SPILLED, DROPPED, WASHED OR TRACKED ONTO PUBLIC ROADWAY MUST BE REMOVED IMMEDIATELY.
 7. DRAINAGE: ENTRANCE MUST BE PROPERLY GRADED OR INCORPORATE A DRAINAGE SWALE TO PREVENT RUNOFF FROM LEAVING THE CONSTRUCTION SITE.

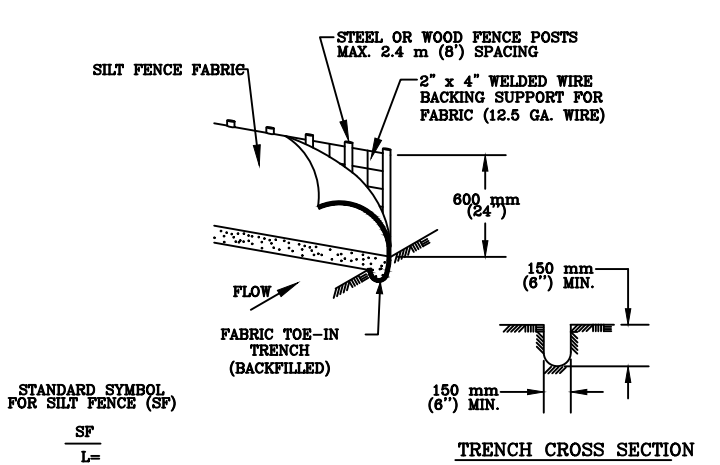

1. STEEL OR WOOD POSTS WHICH SUPPORT THE SILT FENCE SHALL BE INSTALLED ON A SLIGHT ANGLE TOWARD THE ANTICIPATED RUNOFF SOURCE. POST MUST BE EMBEDDED A MINIMUM OF 300 mm (12 INCHES). IF WOOD POSTS CANNOT ACHIEVE 300 mm (12 inches) DEPTH, USE STEEL POSTS.
2. THE TOE OF THE SILT FENCE SHALL BE TRENCHED IN WITH A SPADE OR MECHANICAL TRENCHER, SO THAT THE DOWNSLOPE FACE OF THE TRENCH IS FLAT AND PERPENDICULAR TO THE LINE OF FLOW.
3. THE TRENCH MUST BE A MINIMUM OF 150 mm (6 inches) DEEP AND 150 mm (6 inches) WIDE TO ALLOW FOR THE SILT FENCE FABRIC TO BE LAID IN THE GROUND AND BACKFILLED WITH COMPACTED MATERIAL.
4. SILT FENCE FABRIC SHOULD BE SECURELY PASTENED TO EACH STEEL OR WOOD SUPPORT POST OR TO WOVEN WIRE, WHICH IS IN TURN ATTACHED TO THE STEEL OR WOOD FENCE POST.
5. INSPECTION SHALL BE MADE WEEKLY OR AFTER EACH RAINFALL EVENT AND REPAIR OR REPLACEMENT SHALL BE MADE PROMPTLY AS NEEDED.
6. SILT FENCE SHALL BE REMOVED WHEN THE SITE IS COMPLETELY STABILIZED SO AS NOT TO BLOCK OR IMPEDE STORM FLOW OR DRAINAGE.
7. ACCUMULATED SILT SHALL BE REMOVED WHEN IT REACHES A DEPTH OF 150 mm (6 inches). THE SILT SHALL BE DISPOSED OF ON AN APPROVED SITE AND IN SUCH A MANNER THAT WILL NOT CONTRIBUTE TO ADDITIONAL SILTATION.

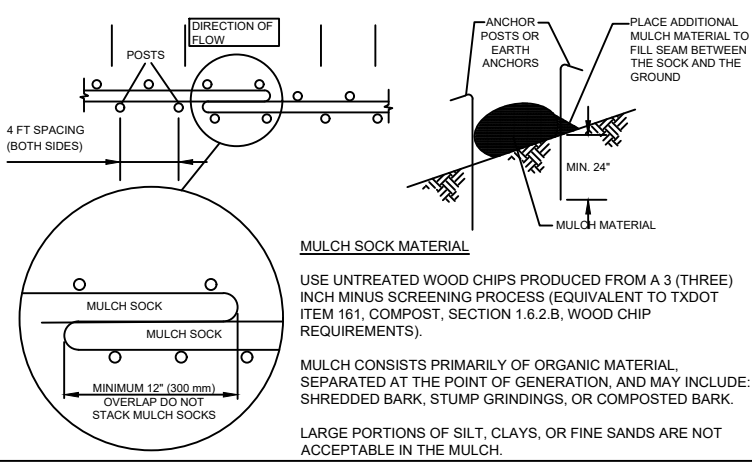

- NOTES:**
1. STEEL OR WOOD POSTS WHICH SUPPORT THE MULCH SOCK SHALL BE INSTALLED ON A SLIGHT ANGLE TOWARD THE ANTICIPATED RUNOFF SOURCE. POST MUST BE EMBEDDED A MINIMUM OF 600mm (24 inches). IF WOOD POSTS CANNOT ACHIEVE 600mm (24 inches) DEPTH, USE STEEL POSTS. EARTH ANCHORS ARE ALSO ACCEPTABLE.
 2. THE TOE OF THE MULCH SOCK SHALL BE PLACED SO THAT THE MULCH SOCK IS FLAT AND PERPENDICULAR TO THE LINE OF FLOW. IN ORDER TO PREVENT WATER FROM FLOWING BETWEEN THE JOINTS OF ADJACENT ENDS OF MULCH SOCKS, LAP THE ENDS OF ADJACENT MULCH SOCKS A MINIMUM OF 300mm (12 inches).
 3. MULCH MATERIAL MUST BE FREE OF REFUSE, PHYSICAL CONTAMINANTS, AND MATERIAL TOXIC TO PLANT GROWTH; IT IS NOT ACCEPTABLE FOR THE MULCH MATERIAL TO CONTAIN GROUND CONSTRUCTION DEBRIS, BIOSOLIDS, OR MANURE.
 4. SOCK MATERIAL WILL BE 100% BIODEGRADABLE, PHOTODEGRADABLE, OR RECYCLABLE SUCH AS BURLAP, TWINE, UV PHOTODEGRADABLE PLASTIC, POLYESTER, OR ANY OTHER ACCEPTABLE MATERIAL.
 5. MULCH SOCKS SHOULD BE USED AT THE BASE OF SLOPES NO STEEPER THAN 2:1 AND SHOULD NOT EXCEED THE MAXIMUM SPACING CRITERIA PROVIDED IN CITY OF AUSTIN ENVIRONMENTAL CRITERIA MANUAL TABLE 1.4.5.F.1 FOR A GIVEN SLOPE CATEGORY.
 6. ACCUMULATED SILT SHALL BE REMOVED WHEN IT REACHES A DEPTH OF 150mm (6 inches). THE SILT SHALL BE DISPOSED OF ON AN APPROVED SITE AND IN SUCH A MANNER THAT WILL NOT CONTRIBUTE TO ADDITIONAL SILTATION.

CITY OF AUSTIN WATERSHED PROTECTION DEPARTMENT	STABILIZED CONSTRUCTION ENTRANCE	STANDARD NO. 641S-1
RECORD COPY SIGNED BY J. PATRICK MURPHY 5/23/00	THE ARCHITECT/ENGINEER ASSUMES RESPONSIBILITY FOR APPROPRIATE USE OF THIS STANDARD.	ADAPTED

CITY OF AUSTIN WATERSHED PROTECTION DEPARTMENT	SILT FENCE	STANDARD NO. 642S-1
RECORD COPY SIGNED BY MORGAN BYARS 09/01/2011	THE ARCHITECT/ENGINEER ASSUMES RESPONSIBILITY FOR APPROPRIATE USE OF THIS STANDARD.	ADAPTED

CITY OF AUSTIN WATERSHED PROTECTION DEPARTMENT	MULCH SOCK	STANDARD NO. 648S-1
RECORD COPY SIGNED BY MORGAN BYARS 08/24/2010	THE ARCHITECT/ENGINEER ASSUMES RESPONSIBILITY FOR APPROPRIATE USE OF THIS STANDARD.	ADAPTED

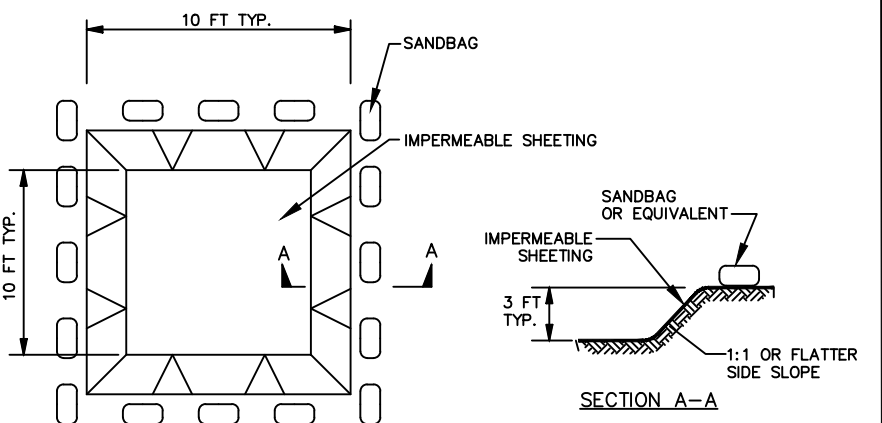

EXCAVATED WASHOUT STRUCTURE

ONSITE CONCRETE WASHOUT STRUCTURE OR APPROVED EQUAL

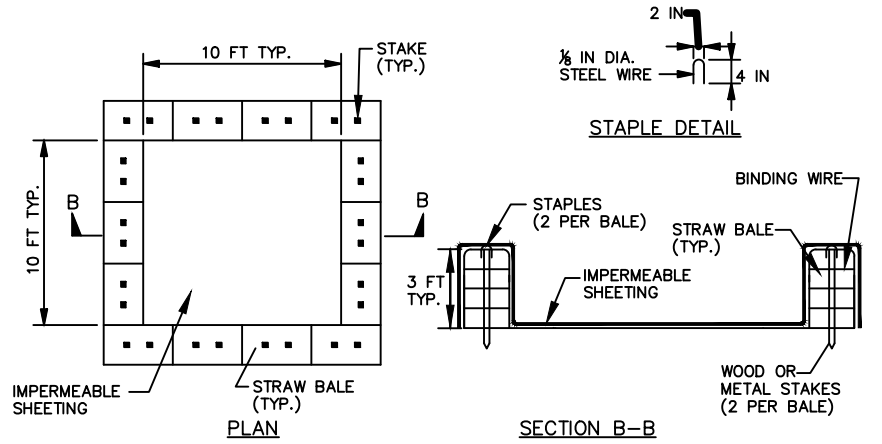

NOTE: CAN BE TWO STACKED BALES OR PARTIALLY EXCAVATED TO REACH 3 FT DEPTH

WASHOUT STRUCTURE WITH STRAW BALES

CONSTRUCTION SPECIFICATIONS

1. LOCATE WASHOUT STRUCTURE A MINIMUM OF 50 FEET AWAY FROM OPEN CHANNELS, STORM DRAIN INLETS, SENSITIVE AREAS, WETLANDS, BUFFERS AND WATER COURSES AND AWAY FROM CONSTRUCTION TRAFFIC.
2. SIZE WASHOUT STRUCTURE FOR VOLUME NECESSARY TO CONTAIN WASH WATER AND SOLIDS AND MAINTAIN AT LEAST 4 INCHES OF FREEBOARD. TYPICAL DIMENSIONS ARE 10 FEET X 10 FEET X 3 FEET DEEP.
3. PREPARE SOIL BASE FREE OF ROCKS OR OTHER DEBRIS THAT MAY CAUSE TEARS OR HOLES IN THE LINER. FOR LINER, USE 10 MIL OR THICKER UV RESISTANT, IMPERMEABLE SHEETING, FREE OF HOLES AND TEARS OR OTHER DEFECTS THAT COMPROMISE IMPERMEABILITY OF THE MATERIAL.
4. PROVIDE A SIGN FOR THE WASHOUT IN CLOSE PROXIMITY TO THE FACILITY.
5. KEEP CONCRETE WASHOUT STRUCTURE WATER TIGHT. REPLACE IMPERMEABLE LINER IF DAMAGED (E.G., RIPPED OR PUNCTURED). EMPTY OR REPLACE WASHOUT STRUCTURE THAT IS 75 PERCENT FULL, AND DISPOSE OF ACCUMULATED MATERIAL PROPERLY. DO NOT REUSE PLASTIC LINER. WET-VACUUM STORED LIQUIDS THAT HAVE NOT EVAPORATED AND DISPOSE OF IN AN APPROVED MANNER. PRIOR TO FORECASTED RAINSTORMS, REMOVE LIQUIDS OR COVER STRUCTURE TO PREVENT OVERFLOWS. REMOVE HARDENED SOLIDS, WHOLE OR BROKEN UP, FOR DISPOSAL OR RECYCLING. MAINTAIN RUNOFF DIVERSION AROUND EXCAVATED WASHOUT STRUCTURE UNTIL STRUCTURE IS REMOVED.

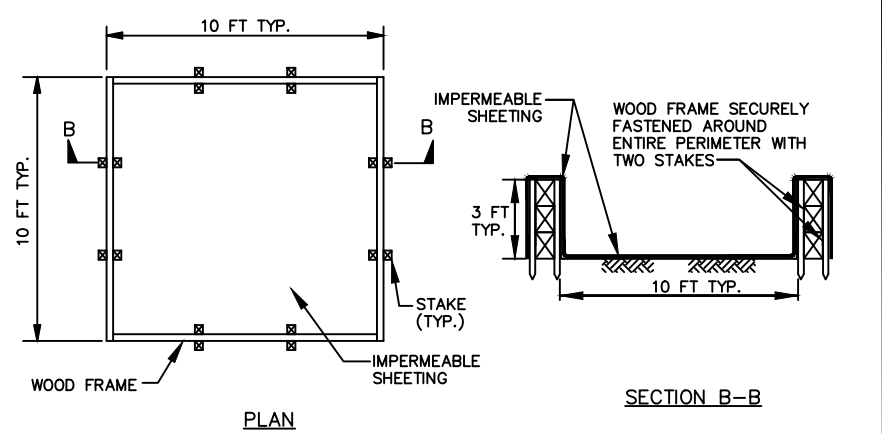

WASHOUT STRUCTURE WITH WOOD PLANKS

REVISION RECORD

EROSION CONTROL DETAILS	<p>ENGINEERING CONSULTING</p> <p>SANDLIN</p> <p>SERVICES, LLC</p> <p>TBPELS FIRM #21356 9111 JOLLVILLE RD., STE. 212 AUSTIN, TX 78759</p>
SHEET 10 OF 10	
P.E.C. LIBERTY HILL EAPP	
EXCELL FUELING SYSTEMS	



**Contributing Zone Plan Application
(TCEQ-10257)**

**Attachment N:
Inspection, Maintenance, Repair and Retrofit Plan
NOT APPLICABLE**

As no additional IC is proposed for the site, the existing and approved BMP inspection, maintenance, repair and retrofit plan is still in effect (CZP EAPP 11-08030503 dated April 16, 2008, and CZP Modification EAPP 11001078 dated May 23, 2018). No changes are needed.



**Contributing Zone Plan Application
(TCEQ-10257)**

**Attachment O:
Pilot-Scale Field Testing Plan, if BMPs not based on complying
with Edwards Aquifer Rules: Technical Guidance for BMPs
(NOT APPLICABLE)**

A pilot-scale field testing plan is not applicable. All BMP design and calculations are based on and comply with Edwards Aquifer Technical Guidance for Edwards Aquifer Rules (RG-348, revised July 2005).



Contributing Zone Plan Application (TCEQ-10257)

Attachment P: Measures for Minimizing Surface Stream Contamination

No surface streams flow across the property. The property drains southwest to an unnamed tributary that drains directly to the South fork San Gabriel River, approximately two (2) miles south of the project site. The existing sand filter basin BMP will continue to address onsite water quality and stormwater drainage to mitigate and minimize offsite surface stream contamination.



*PEC Liberty Hill
CONTRIBUTING ZONE PLAN MODIFICATION*

Temporary Stormwater Section (TCEQ-0602)

Temporary Stormwater Section

Texas Commission on Environmental Quality

for Regulated Activities on the Edwards Aquifer Recharge Zone and Relating to 30 TAC §213.5(b)(4)(A), (B), (D)(I) and (G); Effective June 1, 1999

To ensure that the application is administratively complete, confirm that all fields in the form are complete, verify that all requested information is provided, consistently reference the same site and contact person in all forms in the application, and ensure forms are signed by the appropriate party.

Note: Including all the information requested in the form and attachments contributes to more streamlined technical reviews.

Signature

To the best of my knowledge, the responses to this form accurately reflect all information requested concerning the proposed regulated activities and methods to protect the Edwards Aquifer. This **Temporary Stormwater Section** is hereby submitted for TCEQ review and executive director approval. The application was prepared by:

Print Name of Customer/Agent: Nick Sandlin, P.E. (Sandlin Services, LLC)

Date: 3/20/2024

Signature of Customer/Agent:

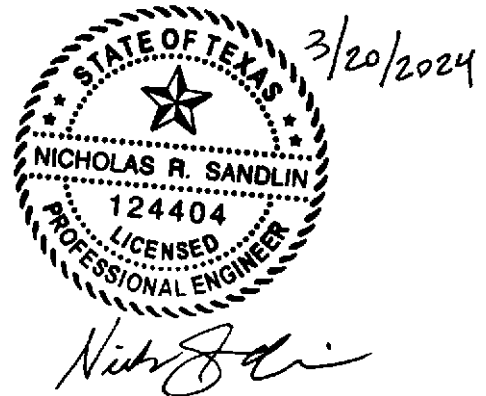

Regulated Entity Name: PEC Liberty Hill

Project Information

Potential Sources of Contamination

Examples: Fuel storage and use, chemical storage and use, use of asphaltic products, construction vehicles tracking onto public roads, and existing solid waste.

1. Fuels for construction equipment and hazardous substances which will be used during construction:

The following fuels and/or hazardous substances will be stored on the site: _____

These fuels and/or hazardous substances will be stored in:

- Aboveground storage tanks with a cumulative storage capacity of less than 250 gallons will be stored on the site for less than one (1) year.

- Aboveground storage tanks with a cumulative storage capacity between 250 gallons and 499 gallons will be stored on the site for less than one (1) year.
- Aboveground storage tanks with a cumulative storage capacity of 500 gallons or more will be stored on the site. An Aboveground Storage Tank Facility Plan application must be submitted to the appropriate regional office of the TCEQ prior to moving the tanks onto the project.
- Fuels and hazardous substances will not be stored on the site.
- 2. **Attachment A - Spill Response Actions.** A site specific description of the measures to be taken to contain any spill of hydrocarbons or hazardous substances is attached.
- 3. Temporary aboveground storage tank systems of 250 gallons or more cumulative storage capacity must be located a minimum horizontal distance of 150 feet from any domestic, industrial, irrigation, or public water supply well, or other sensitive feature.
- 4. **Attachment B - Potential Sources of Contamination.** A description of any activities or processes which may be a potential source of contamination affecting surface water quality is attached.

Sequence of Construction

- 5. **Attachment C - Sequence of Major Activities.** A description of the sequence of major activities which will disturb soils for major portions of the site (grubbing, excavation, grading, utilities, and infrastructure installation) is attached.
 - For each activity described, an estimate (in acres) of the total area of the site to be disturbed by each activity is given.
 - For each activity described, include a description of appropriate temporary control measures and the general timing (or sequence) during the construction process that the measures will be implemented.
- 6. Name the receiving water(s) at or near the site which will be disturbed or which will receive discharges from disturbed areas of the project: South Fork San Gabriel River

Temporary Best Management Practices (TBMPs)

Erosion control examples: tree protection, interceptor swales, level spreaders, outlet stabilization, blankets or matting, mulch, and sod. Sediment control examples: stabilized construction exit, silt fence, filter dikes, rock berms, buffer strips, sediment traps, and sediment basins. Please refer to the Technical Guidance Manual for guidelines and specifications. All structural BMPs must be shown on the site plan.

- 7. **Attachment D – Temporary Best Management Practices and Measures.** TBMPs and measures will prevent pollution of surface water, groundwater, and stormwater. The construction-phase BMPs for erosion and sediment controls have been designed to retain sediment on site to the extent practicable. The following information is attached:

- A description of how BMPs and measures will prevent pollution of surface water, groundwater or stormwater that originates upgradient from the site and flows across the site.
 - A description of how BMPs and measures will prevent pollution of surface water or groundwater that originates on-site or flows off site, including pollution caused by contaminated stormwater runoff from the site.
 - A description of how BMPs and measures will prevent pollutants from entering surface streams, sensitive features, or the aquifer.
 - A description of how, to the maximum extent practicable, BMPs and measures will maintain flow to naturally-occurring sensitive features identified in either the geologic assessment, TCEQ inspections, or during excavation, blasting, or construction.
8. The temporary sealing of a naturally-occurring sensitive feature which accepts recharge to the Edwards Aquifer as a temporary pollution abatement measure during active construction should be avoided.
- Attachment E - Request to Temporarily Seal a Feature.** A request to temporarily seal a feature is attached. The request includes justification as to why no reasonable and practicable alternative exists for each feature.
 - There will be no temporary sealing of naturally-occurring sensitive features on the site.
9. **Attachment F - Structural Practices.** A description of the structural practices that will be used to divert flows away from exposed soils, to store flows, or to otherwise limit runoff discharge of pollutants from exposed areas of the site is attached. Placement of structural practices in floodplains has been avoided.
10. **Attachment G - Drainage Area Map.** A drainage area map supporting the following requirements is attached:
- For areas that will have more than 10 acres within a common drainage area disturbed at one time, a sediment basin will be provided.
 - For areas that will have more than 10 acres within a common drainage area disturbed at one time, a smaller sediment basin and/or sediment trap(s) will be used.
 - For areas that will have more than 10 acres within a common drainage area disturbed at one time, a sediment basin or other equivalent controls are not attainable, but other TBMPs and measures will be used in combination to protect down slope and side slope boundaries of the construction area.
 - There are no areas greater than 10 acres within a common drainage area that will be disturbed at one time. A smaller sediment basin and/or sediment trap(s) will be used in combination with other erosion and sediment controls within each disturbed drainage area.

- There are no areas greater than 10 acres within a common drainage area that will be disturbed at one time. Erosion and sediment controls other than sediment basins or sediment traps within each disturbed drainage area will be used.
11. **Attachment H - Temporary Sediment Pond(s) Plans and Calculations.** Temporary sediment pond or basin construction plans and design calculations for a proposed temporary BMP or measure have been prepared by or under the direct supervision of a Texas Licensed Professional Engineer. All construction plans and design information must be signed, sealed, and dated by the Texas Licensed Professional Engineer. Construction plans for the proposed temporary BMPs and measures are attached.
- N/A
12. **Attachment I - Inspection and Maintenance for BMPs.** A plan for the inspection of each temporary BMP(s) and measure(s) and for their timely maintenance, repairs, and, if necessary, retrofit is attached. A description of the documentation procedures, recordkeeping practices, and inspection frequency are included in the plan and are specific to the site and/or BMP.
13. All control measures must be properly selected, installed, and maintained in accordance with the manufacturer's specifications and good engineering practices. If periodic inspections by the applicant or the executive director, or other information indicate a control has been used inappropriately, or incorrectly, the applicant must replace or modify the control for site situations.
14. If sediment escapes the construction site, off-site accumulations of sediment must be removed at a frequency sufficient to minimize offsite impacts to water quality (e.g., fugitive sediment in street being washed into surface streams or sensitive features by the next rain).
15. Sediment must be removed from sediment traps or sedimentation ponds not later than when design capacity has been reduced by 50%. A permanent stake will be provided that can indicate when the sediment occupies 50% of the basin volume.
16. Litter, construction debris, and construction chemicals exposed to stormwater shall be prevented from becoming a pollutant source for stormwater discharges (e.g., screening outfalls, picked up daily).

Soil Stabilization Practices

Examples: establishment of temporary vegetation, establishment of permanent vegetation, mulching, geotextiles, sod stabilization, vegetative buffer strips, protection of trees, or preservation of mature vegetation.

17. **Attachment J - Schedule of Interim and Permanent Soil Stabilization Practices.** A schedule of the interim and permanent soil stabilization practices for the site is attached.

18. Records must be kept at the site of the dates when major grading activities occur, the dates when construction activities temporarily or permanently cease on a portion of the site, and the dates when stabilization measures are initiated.
19. Stabilization practices must be initiated as soon as practicable where construction activities have temporarily or permanently ceased.

Administrative Information

20. All structural controls will be inspected and maintained according to the submitted and approved operation and maintenance plan for the project.
21. If any geologic or manmade features, such as caves, faults, sinkholes, etc., are discovered, all regulated activities near the feature will be immediately suspended. The appropriate TCEQ Regional Office shall be immediately notified. Regulated activities must cease and not continue until the TCEQ has reviewed and approved the methods proposed to protect the aquifer from any adverse impacts.
22. Silt fences, diversion berms, and other temporary erosion and sediment controls will be constructed and maintained as appropriate to prevent pollutants from entering sensitive features discovered during construction.



Temporary Stormwater Section (TCEQ-0602)

Attachment A: Spill Response Actions

Spill Response Actions

In the event of an accidental spill, immediate action shall be undertaken by the General Contractor to contain and remove the spilled material. All hazardous materials, including contaminated soil and liquid concrete waste (if applicable), shall be disposed of by the Contractor in the manner specified by Federal, State and Local regulations and by the manufacturer of such products. As soon as possible, the spill shall be reported to the appropriate agencies. As required under the provisions of the Clean Water Act, any spill or discharge entering waters of the United States shall be properly reported. The General Contractor shall prepare a written record of any spill and associated clean-up activities of petroleum products or hazardous materials in excess of 1 gallon or reportable quantities, whichever is less. The General Contractor shall provide notice to the Owner immediately upon identification of a reportable spill.

All spills of petroleum products or hazardous materials in excess of Reportable Quantities as defined by EPA or the State or Local agency regulations, shall be immediately reported within 24 hours to the EPA National Response Center (1-800-424-8802), TCEQ (1-800-832-8224), and local Fire Department (911).

The reportable quantity for hazardous materials can be found in 40 CFR 302:

Reportable Quantities		
Material	Media Released to	Reportable Quantities
Engine Oil, Fuel, Hydraulic & Brake Fluid	Land	25 gallons
Engine Oil, Fuel, Hydraulic & Brake Fluid	Water	Visible sheen
Antifreeze	Land	100 lbs (13 gal.)
Battery Acid	Land, Water	100 lbs
Refrigerant	Air	1 lb
Gasoline	Air, Land, Water	100 lbs
Engine Degreasers	Air, Land, Water	100 lbs

For more information, please visit https://www.tceq.texas.gov/response/spills/spill_rq.html

In order to minimize the potential for a spill of petroleum product or hazardous materials to come in contact with stormwater, the following steps shall be implemented.

- 1) All materials with hazardous properties (such as pesticides, petroleum products, fertilizers, detergents, construction chemicals, acids paints, paint solvents, additives for soil stabilization,



concrete curing compounds and additives, etc.) shall be stored in a secure location, under cover and in appropriate, tightly sealed containers when not in use.

- 2) The minimum practical quantity of all such materials shall be kept on the job site and scheduled for delivery as close to the time of use as practical. Post Material Safety Data Sheets (MSDS), as well as proper storage, cleanup, and spill reporting instructions for hazardous materials stored or used on the project site in an open, conspicuous, and accessible location.
- 3) A spill control and containment kit (containing for example: absorbent material such as kitty litter or sawdust, acid neutralizing agent, brooms, dust pans, mops, rags, gloves, goggles, plastic and metal trash containers, etc.) shall be provided on the construction site and construction employees shall be trained in when and how to use spill containment materials.
- 4) The contractor personnel will immediately clean up any oil, fuel or hydraulic fluid if observed being released from equipment or vehicles. Vehicles or equipment will cease operation until required repairs are made to the equipment.
- 5) All of the product in a container shall be used before the container is disposed of. All such containers shall be triple rinsed with water prior to disposal. The rinse water used in these containers shall be disposed of in a manner in compliance with State and Federal regulations and shall not be allowed to mix with stormwater discharges.
- 6) All products shall be stored in and used from the original container with the original product label.
- 7) All products shall be used in strict compliance with instructions on the product label.
- 8) The disposal of the excess or used products shall be in strict compliance with instructions on the product's label.

Spill Prevention and Control

Education

- 1) Be aware that different materials pollute in different amounts. Make sure that each employee knows what a "significant spill" is for each material they use, and what is the appropriate response for "significant" and "insignificant" spills. Employees should also be aware of when a spill must be reported to the TCEQ. Information is available in 30 TAC 327.4 and 40 CFR 302.4.
- 2) Educate employees and subcontractors on potential dangers to humans and the environment from spills and leaks.
- 3) Hold regular meetings to discuss and reinforce appropriate disposal procedures (incorporate into regular safety meetings).
- 4) Establish a continuing education program to indoctrinate new employees.
- 5) Have contractor's superintendent or representative oversee and enforce proper spill prevention and control measures.



General Measures

- 1) To the extent that the work can be accomplished safely, spills of oil, petroleum products, substances listed under 40 CFR parts 110, 117, and 302, and sanitary and septic wastes should be contained and cleaned up immediately.
- 2) Store hazardous materials and wastes in covered containers and protect from vandalism.
- 3) Place a stockpile of spill cleanup materials where it will be readily accessible.
- 4) Train employees in spill prevention and cleanup.
- 5) Designate responsible individuals to oversee and enforce control measures.
- 6) Spills should be covered and protected from stormwater run-on during rainfall to the extent that it doesn't compromise cleanup activities.
- 7) Do not bury or wash spills with water.
- 8) Store and dispose of used clean up materials, contaminated materials, and recovered spill material that is no longer suitable for the intended purpose in conformance with the provisions in applicable BMPs.
- 9) Do not allow water used for leaning and decontamination to enter storm drains or watercourses. Collect and dispose of contaminated water in accordance with applicable regulations.
- 10) Contain water overflow or minor water spillage and do not allow it to discharge into drainage facilities or watercourses.
- 11) Place Material Safety Data Sheets (MSDS), as well as proper storage, cleanup, and spill reporting instructions for hazardous materials stored or used on the project site in an open, conspicuous, and accessible location.
- 12) Keep waste storage areas clean, well-organized, and equipped with ample cleanup supplies as appropriate for the materials being stored. Perimeter controls, containment structures, covers, and liners should be repaired or replaced as needed to maintain proper function.

Cleanup

- 1) Clean up leaks and spills immediately.
- 2) Use a rag for small spills on paved surfaces, a damp mop for general cleanup, and absorbent material for larger spills. If the spilled material is hazardous, then the used cleanup materials are also hazardous and must be disposed of as hazardous waste.
- 3) Never hose down or bury dry material spills. Clean up as much of the material as possible and dispose of it properly. See the waste management BMPs in this section for specific information.

Minor Spills

- 1) Minor spills typically involve small quantities of oil, gasoline, paint, etc. which can be controlled by the first responder at the discovery of the spill.
- 2) Use absorbent materials on small spills rather than hosing down or burying the spill.
- 3) Absorbent materials should be promptly removed and disposed of properly.



- 4) Follow the practice below for a minor spill:
- 5) Contain the spread of the spill.
- 6) Recover spilled materials.
- 7) Clean the contaminated area and properly dispose of contaminated materials.

Semi-Significant Spills

Semi-significant spills still can be controlled by the first responder along with the aid of other personnel such as laborers and the foreman, etc. This response may require the cessation of all other activities. Spills should be cleaned up immediately.

- 1) Contain spread of the spill.
- 2) Notify the project foreman immediately.
- 3) If the spill occurs on paved or impermeable surfaces, clean up using “dry” methods (absorbent materials, cat litter and/or rags). Contain the spill by encircling with absorbent materials and do not let the spill spread widely.
- 4) If the spill occurs in dirt areas, immediately contain the spill by constructing an earthen dike. Dig up and properly dispose of contaminated soil.
- 5) If the spill occurs during rain, cover the spill with tarps or other material to prevent contaminating runoff.

Significant/Hazardous Spills

For significant or hazardous spills that are in reportable quantities:

- 1) Notify the TCEQ by telephone as soon as possible and within 24 hours at 512-339-2929 (Austin) or 210-490-3096 (San Antonio) between 8 AM and 5 PM. After hours, contact the Environmental Release Hotline at 1-800-832-8224. It is the contractor’s responsibility to have all emergency phone numbers at the construction site.
- 2) For spills of federal reportable quantities, in conformance with the requirements in 40 CFR parts 110,009, and 302, the contractor should notify the National Response Center at (800)424-8802.
- 3) Notification should first be made by telephone and followed up with a written report.
- 4) The services of a spill’s contractor or a Haz-Mat team should be obtained immediately. Construction personnel should not attempt to clean up until the appropriate and qualified staff have arrived at the job site.
- 5) Other agencies which may need to be consulted include, but are not limited to, the City Police Department, County sheriff Office, Fire Departments, etc.

More information on spill rules and appropriate responses is available on the TCEQ website at: <https://www.tceq.texas.gov/downloads/compliance/investigations/spills/spill-poster-x.pdf>

Vehicle and Equipment Maintenance

- 1) If maintenance must occur onsite, use a designated area and a secondary containment, located away from drainage course, to prevent the runoff of stormwater and the runoff of spills.



- 2) Regularly inspect onsite vehicles and equipment for leaks and repair immediately.
- 3) Check incoming vehicles and equipment (including delivery trucks, and employee and subcontractor vehicles) for leaking oil and fluids. Do not allow leaking vehicles or equipment onsite.
- 4) Always use secondary containment, such as a drain pan or drop cloth, to catch spills or leaks when removing or changing fluids.
- 5) Place drip pans or absorbent materials under paving equipment when not in use.
- 6) Use absorbent materials on small spills rather than hosing down or burying the spill. Remove the absorbent materials promptly and dispose of them properly.
- 7) Promptly transfer used fluids to the proper waste or recycling drums. Don't leave full drip pans or other open containers lying around.
- 8) Oil filters disposed of in trashcans or dumpsters can leak oil and pollute stormwater. Place the oil filter in a funnel over a waste oil-recycling drum to drain excess oil before disposal. Oil filters can also be recycled. Ask the oil supplier or recycler about recycling oil filters.
- 9) Store cracked batteries in a non-leaking secondary container. Do this with all cracked batteries even if you think all the acid has drained out. If you drop a battery, treat it as if it is cracked. Put it into the containment area until you are sure it is not leaking.

Vehicle and Equipment Fueling

- 1) If fueling must occur on site, use designated areas, located away from drainage courses, to prevent the runoff of stormwater and the runoff of spills.
- 2) Discourage 'topping off' of fuel tanks.

Always use secondary containment, such as a drain pan, when fueling to catch spills/leaks.

SPILL REPORT FORM

Notes to General Contractor:

- Control and contain the spill.
- Contact the appropriate regulatory agencies if the spill exceeds the applicable reportable quantity.
- Clean up the spill and dispose of waste according to federal, state and local regulations.
- Complete the Spill Report Form in full for each spill that exceeds the applicable reportable quantity and submit to the Owner.
- Call the Owner.
- Resolve as appropriate and as required by regulatory authorities.



SPILL REPORT FORM

DATE:
PROJECT:
PROJECT ADDRESS:

Spill Reported By: _____

Date / Time of Spill: _____

Describe spill location and events leading to spill: _____

Material Spilled: _____

Source of Spill: _____

Amount Spilled: _____

Amount Spilled to Waterway (Name Waterway): _____

Containment or Clean up Action: _____

Approximate depth (yards) of soil excavation: _____

List injuries or Personal Contamination: _____

Action to be taken to prevent future spills:

Agencies notified of spill:

Contractor Signature and Printed Name

Date

**AFTER NOTIFYING GOVERNING AUTHORITIES, IMMEDIATELY COMPLETE THIS FORM
AND CONTACT THE OWNER IF THE SPILL EXCEEDS THE REPORTABLE QUANTITY FOR
THE GOVERNING AGENCY**



Temporary Stormwater Section (TCEQ-0602)

Attachment B: Potential Sources of Contamination

Potential Sources of Contamination and Preventive Measures:

Potential Source: Concrete and concrete products used on-site during construction.

Preventive Measures: Concrete washout structure will be used if necessary.

Potential Source: Oil, grease, fuel, and hydraulic fluid contamination from construction equipment and vehicle dripping.

Preventive Measures: Vehicle maintenance will be performed at a local maintenance shop.

Potential Source: Miscellaneous trash and litter from construction workers and material wrappings.

Preventive Measures: Trash containers will be placed throughout the site to encourage proper disposal of trash.

Potential Source: Silt leaving the site

Preventive Measures: Contractor will install all temporary best management practices prior to start of construction including the stabilized construction entrance to prevent tracking onto adjoining streets.

Potential Source: Construction debris

Preventive Measures: Construction debris will be monitored daily by contractor. Debris will be collected weekly and placed in disposal bins. Situations requiring immediate attention will be addressed on a case by case basis.

Potential Source: Soil and mud from construction vehicle tires as they leave the site.

Preventive Measures: a stabilized construction exit shall be utilized as vehicles leave the site. And soil, mud, etc. carried from the project onto public roads shall be cleaned up within 24 hours.

Potential Source: Sediment from soil, sand, gravel, and excavated materials stockpiled on site.

Preventive Measures: Silt fence shall be installed on the down gradient side of the stockpiled materials. Reinforced rock berms shall be installed at all downstream discharge locations.

Potential Source: Portable toilet spill

Preventive Measures: Toilets on the site will be emptied on a regular basis by the contracted toilet company.



Temporary Stormwater Section (TCEQ-0602)

Attachment C: Sequence of Major Activities

The installation of erosion and sedimentation controls shall occur prior to any excavation of materials or major disturbances on the site. The sequence of major construction activities will be as follows. Approximate acreage (AC) to be disturbed is listed in parentheses next to each activity.

Intended Schedule or Sequence of Major Activities:

1. Submit written notice of construction to TCEQ regional office at least 48 hours prior to the start of any regulated activities.
2. A pre-construction conference prior to commencement of construction. All contractors conducting regulated activities associated with this project must be provided with complete copies of the approved Contributing Zone Plan (CZP) and the TCEQ letter indicating the specific conditions of its approval. During the course of these regulated activities, the contractors are required to keep on-site copies of the approved plan and approval letter.
3. Contractors must follow requirements as outlined in TCEQ General Construction Notes for the Contributing Zone Plan (CZP). CZP Construction Notes are listed in the Construction Plans (Attachment M of the Contributing Zone Plan Application section).
4. Prior to beginning any construction activity, all temporary erosion and sedimentation BMPs and control measures must be properly installed and maintained in accordance with the approved plans and manufacturers specifications (0.15 Acres).
5. Evaluate temporary erosion control installation. If inspections indicate a control has been used inappropriately, or incorrectly, the applicant must replace or modify the control for site situations. These controls must remain in place until the disturbed areas have been permanently stabilized.
6. Review construction schedule and the Contributing Zone Plan (CZP) requirements.
7. Install the AST (0.15 Acres).
8. Piping and ancillary equipment installation.
9. Install tank fittings and other associated equipment.
10. Site cleanup and removal of temporary erosion/sedimentation BMP controls. (0.15 Acres)



Temporary Stormwater Section (TCEQ-0602)

Attachment D: Temporary Best Management Practices and Measures

1. There is approximately 0.0 AC of storm water that originates up gradient from the site and flows through the existing onsite BMP.
2. Temporary BMPs will be installed prior to soil disturbing construction activity. Silt fencing will be placed along the down-gradient sides of the property and limits of construction to prevent silt from escaping the construction area during permanent BMP construction.
3. A concrete washout pit may be used to collect all excess concrete during construction, if needed.
4. Temporary BMPs for this project will protect surface water or groundwater from turbid water, phosphorus, sediment, oil and other contaminants, which may mobilize in stormwater flows by slowing the flow of runoff to allow sediment and suspended solids to settle out of the runoff.
5. Practices may also be implemented on site for interim and permanent stabilization. Stabilization practices may include but are not limited to establishment of temporary vegetation; establishment of permanent vegetation; mulching; geotextiles; sod stabilization; vegetative buffer strips; protection of existing trees and vegetation; and other similar measures.
6. There are no sensitive features or surface streams within the boundaries of the project that would require temporary BMPs. The temporary onsite BMPs will be used to treat stormwater runoff before it leaves the project and prevent pollutants from entering surface streams or any sensitive features down gradient of the site.



**Temporary Stormwater Section
(TCEQ-0602)**

**Attachment E:
Request to Temporarily Seal a Feature
(NOT APPLICABLE)**



Temporary Stormwater Section (TCEQ-0602)

Attachment F: Structural Practices

Structural BMPs will be used to limit runoff discharge of pollutants from exposed areas of the site. BMPs will be installed prior to soil disturbing construction activity. Silt fencing will be placed along the down-gradient sides of the property to prevent silt from escaping the construction area. A temporary construction entrance will be placed at the site entry/exit point to reduce tracking onto adjoining streets. A construction staging area will be used onsite to perform all vehicle maintenance and for equipment and material storage. A concrete truck washout pit will be placed on site to provide containment and easier cleanup of waste from concrete operations. The location of all structural temporary BMPs are shown within the Site Plans.

Description of Temporary BMPs

Fiber Roll:

The purpose of a fiber roll is to intercept and detain water-borne sediment from unprotected areas of a limited extent. Fiber rolls are used during the period of construction near the perimeter of a disturbed area to intercept sediment, reduce flow velocity, and release runoff as sheet flow. If concentrated flow occurs after installation, corrective action must be taken such as placing a rock berm in the areas of concentrated flow.

Triangular Sediment Filter Dikes

Triangular sediment filter dikes (18"x18"x18" filter material with 6" square folded wire mesh frame) will be installed downgradient of the AST construction area with filter cloth placed over any existing stormwater collection drains. The dike and filter cloth will be held in place with cloth sandbags. The facility existing topography will not change as the AST will be placed on existing crushed rock.

Concrete Washout Area

The purpose of concrete washout areas is to prevent or reduce the discharge of pollutants to stormwater from concrete waste by conducting washout offsite, performing onsite washout in a designated area, and training employees and subcontractors.

The following steps will help reduce stormwater pollution from concrete wastes:

- Incorporate requirements for concrete waste management into material supplier and subcontractor agreements.
- Avoid mixing excess amounts of fresh concrete.
- Perform washout of concrete trucks in designated areas only.
- Do not wash out concrete trucks into storm drains, open ditches, streets, or streams.
- Do not allow excess concrete to be dumped onsite, except in designated areas.
- For onsite washout:



- Locate washout area at least 50 feet from sensitive features, storm drains, open ditches, or water bodies. Do not allow runoff from this area by constructing a temporary pit or bermed area large enough for liquid and solid waste.
- Wash out wastes into the temporary pit where the concrete can set, be broken up, and then disposed properly.



**Temporary Stormwater Section
(TCEQ-0602)**

**Attachment G:
Drainage Area Map**

6.22 ACRES
 LOT 2 OF SEWARD JUNCTION
 COMMERCIAL PARK SUBDIVISION

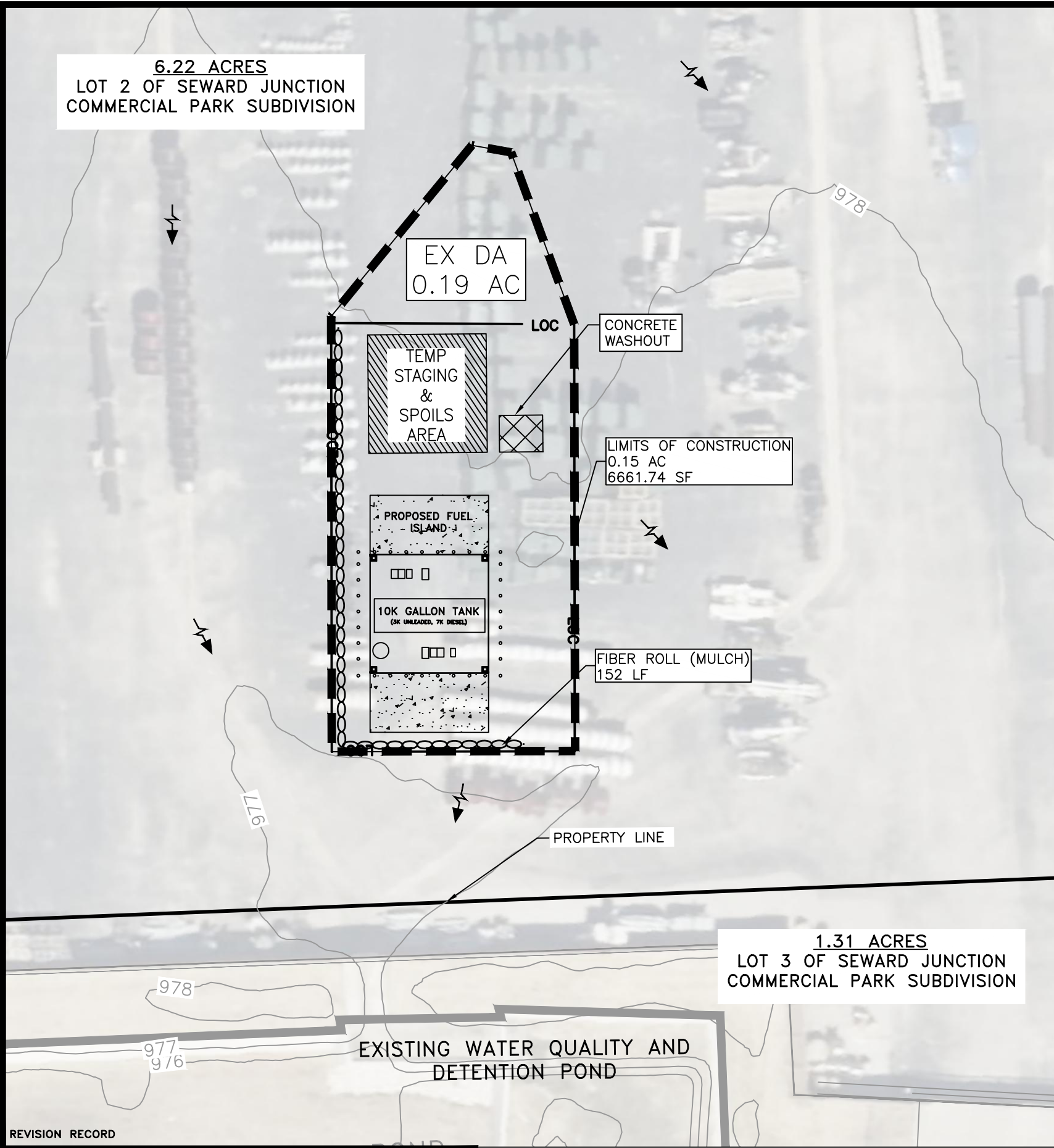

1.31 ACRES
 LOT 3 OF SEWARD JUNCTION
 COMMERCIAL PARK SUBDIVISION

REVISION RECORD

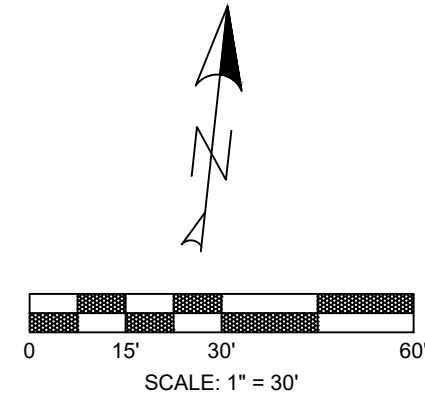







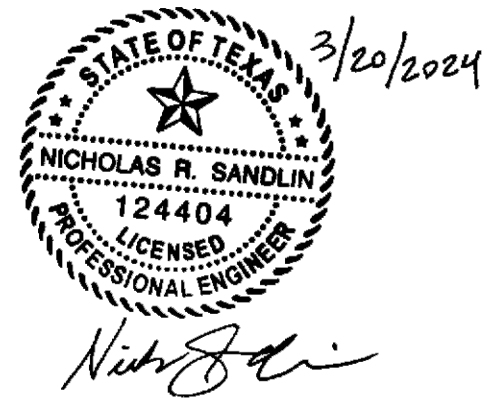





IF DRAWING BAR DOES NOT MEASURE 2"
 THIS PRINT IS NOT TO SCALE

NOTES:

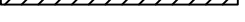
1. THIS PROJECT IS SUBMITTED WITHOUT PHASING.
2. ALL EXISTING IMPERVIOUS COVER AND DRAINAGE PATTERNS WILL REMAIN UNCHANGED POST-DEVELOPMENT.
3. CONTRACTOR TO CUT AND REMOVE CONCRETE AS NECESSARY TO REMOVE ALL EXISTING PIPING. REFER TO PLANS BY OTHERS FOR EXACT LOCATION OF DISPENSERS AND PIPING.
4. ALL REQUIRED NOTICES AND PERMITS MUST BE PLACED IN A HIGHLY VISIBLE LOCATION ONSITE BEFORE THE COMMENCEMENT OF CONSTRUCTION.
5. ALL EROSION AND SEDIMENTATION CONTROLS (ESC) MUST BE INSTALLED PRIOR TO ANY DISTURBANCE TO THE PROJECT SITE.
6. ALL ESC USED ONSITE MUST BE REGULARLY MONITORED AND MAINTAINED AS NEEDED.
7. THE STABILIZED CONSTRUCTION ENTRANCE SHALL BE MAINTAINED IN A CONDITION THAT PREVENTS TRACKING ONTO THE PUBLIC ROADWAY ON AN ONGOING/REGULAR BASIS. MUD AND OR DIRT TRACKED INTO THE ROADWAY MUST BE IMMEDIATELY REMOVED UPON DISCOVERY.
8. INLET PROTECTION SHALL BE INSTALLED IMMEDIATELY UPON INLET INSTALLATION.
9. INITIATE TEMPORARY STABILIZATION WHEN CONSTRUCTION CEASES IN A DISTURBED AREA FOR 14 DAYS.
10. INITIATE PERMANENT STABILIZATION IMMEDIATELY ONCE WORK HAS CEASED AND FINAL GRADE HAS BEEN ACHIEVED.
11. ALL DISTURBED/BARE AREAS WILL REQUIRE PERMANENT STABILIZATION BEFORE FINAL ACCEPTANCE CAN BE ACHIEVED. AVOID DISTURBING AREAS OF THE PROJECT THAT ARE NOT NECESSARY FOR CONSTRUCTION.
12. TEMPORARY ESC'S SHALL REMAIN IN PLACE IN ALL DISTURBED AREAS UNTIL ADEQUATE STABILIZATION HAS BEEN ACHIEVED.
13. THE TECHNICAL SPECS OF ESC DEVICES AND BEST MANAGEMENT PRACTICES (BMP) MEET OR EXCEED THE CITY OF AUSTIN ENVIRONMENTAL CRITERIA MANUAL.
14. PER PLANS BY OTHERS, EXISTING WATER QUALITY AND DETENTION POND HAS CAPACITY FOR AND WILL TREAT RUNOFF DURING CONSTRUCTION AND IN THE PROPOSED CONDITION.
15. NO INCREASED RUNOFF OR TSS WILL RESULT FROM THIS FUEL ISLAND AND TANK CONSTRUCTION.
16. IMPERVIOUS COVER PERCENTAGE ON-SITE WILL NOT INCREASE POST-DEVELOPMENT.

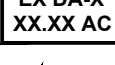

LEGEND

-  PROPOSED PROPERTY/PROJECT BOUNDARY LINE
 -  EXISTING R.O.W./PROPERTY LINE
 -  EXISTING EASEMENT LINE
 -  PROPOSED CURB & GUTTER LIMITS OF CONSTRUCTION
 -  LIMITS OF CONSTRUCTION
 -  FIBER ROLL (MULCH)
 -  STAGING & TEMPORARY SPOILS AREA
 -  STABILIZED CONSTRUCTION ENTRANCE
 -  CONCRETE WASHOUT
- NOTE: ADDITIONAL EROSION CONTROL MEASURES MAY BE REQUIRED BY INSPECTOR AT TIME OF CONSTRUCTION.
-  DRAINAGE AREA BOUNDARY
 -  DRAINAGE AREA DESIGNATION AND AREA DRAINED
 -  FLOW ARROW

EROSION CONTROL AND DRAINAGE PLAN	 SANDLIN SERVICES, LLC <small>ENGINEERING CONSULTING</small> TBPELS FIRM #21356 9111 JOLLVILLE RD., STE. 212 AUSTIN, TX 78759
SHEET 8 OF 10	
P.E.C. LIBERTY HILL EAPP	
EXCELL FUELING SYSTEMS	



**Temporary Stormwater Section
(TCEQ-0602)**

**Attachment H:
Temporary Sediment Pond(s) Plans and Calculations
(NOT APPLICABLE)**



Temporary Stormwater Section (TCEQ-0602)

Attachment I: Inspection and Maintenance for BMPs

Inspection and Maintenance Guidelines for Construction BMPs

Fiber Rolls – Section 1.4.14

- (1) Inspect and verify that activity based BMPs are in place prior to the commencement of associated activities. While activities associated with the BMP are under way, inspect weekly to verify continued BMP implementation.
- (2) Inspect BMPs subject to non-stormwater discharges daily while non-stormwater discharges occur.
- (3) Unit-specific maintenance requirements are included with the description of each technology.
- (4) Sediment removed during the maintenance of a dewatering device may be either spread onsite and stabilized or disposed of at a disposal site.
- (5) Sediment that is commingled with other pollutants must be disposed of in accordance with all applicable laws and regulations.

Personnel Responsible for Inspections

The agent that performs the inspections should be knowledgeable of this general permit, familiar with the construction site, and knowledgeable of the SWPPP for the site. Documentation of the inspector's qualifications is to be included in the attached Inspector Qualifications Log.

Inspection Schedule

The primary operator is required to choose one of the two inspections listed below.

- Option 1:** Once every seven calendar days. If this alternative schedule is developed, then the inspection must occur regardless of whether or not there has been a rainfall event since the previous inspection.

- Option 2:** Once every 14 calendar days and within 24 hours of the end of a storm event of two inches or greater.

The inspections may occur on either schedule provided that documentation reflects the current schedule and that any changes to the schedule are conducted in accordance with the following provisions: the schedule may be changed a maximum of one time each month, the schedule change must be implemented at the beginning of a calendar month, and the reason for the schedule change must be documented (e.g., end of “dry” season and beginning of “wet” season).



If option 2 is the chosen frequency of inspections a rain gauge must be properly maintained on site or the storm event information from a weather station that is representative of the site location. For any day of rainfall during normal business hours that measures 0.25 inches or greater, proper documentation of the total rainfall measured for that day must be recorded.

Personnel provided by the permittee must inspect:

- disturbed areas of the construction site that have not been finally stabilized
- areas used for storage of materials that are exposed to precipitation
- structural controls (for evidence of, or the potential for, pollutants entering the drainage system)
- sediment and erosion control measures identified in the SWP3 (to ensure they are operating correctly), and
- locations where vehicles enter or exit the site (for evidence of off-site sediment tracking)

Reductions in Inspection Frequency

Where sites have been finally or temporarily stabilized or where runoff is unlikely due to winter conditions (e.g., site is covered with snow, ice, or frozen ground exists), inspections must be conducted at least once every month. In arid, semi-arid, or drought-stricken areas, inspections must be conducted at least once every month and within 24 hours after the end of a storm event of 0.5 inches or greater. A record of the total rainfall measured, as well as the approximate beginning and ending dates of winter or drought conditions resulting in monthly frequency of inspections in the attached Rain Gauge Log.

In the event of flooding or other uncontrollable situations which prohibit access to the inspection sites, inspections must be conducted as soon as access is practicable.

Inspection Report Forms

Use the Inspection Report Forms given as a checklist to ensure that all required areas of the construction site are addressed. There is space to document the inspector's name as well as when the inspections regularly take place. The tables will document that the required area was inspected. (If there were any areas of concern, briefly describe them in this space with a more detailed description in the narrative section. Use the last table to document any discharges found during the inspections).

Describe how effective the installed BMPs are performing. Describe any BMP failures that were noted during the investigation and describe any maintenance required due to the failure. If new BMPs are needed as the construction site changes, the inspector can use the space at the bottom of the section to list BMPs to be implemented before the next inspection.

Describe the inspector's qualifications, how the inspection was conducted, and describe any areas of non-compliance in detail. If an inspection report does not identify any incidents of non-compliance, then it must contain a certifying signature stating that the facility or site is in compliance. The report must be signed by a person and in a manner required by 30 TAC 305.128. There is space at the end of the form to allow for this certifying signature.

Whenever an inspection shows that BMP modifications are needed to better control pollutants in runoff, the changes must be completed within seven calendar days following the inspection. If existing BMPs are



modified or if additional BMPs are needed, you must describe your implementation schedule, and wherever possible, make the required BMP changes before the next storm event.

The Inspection Report Form functions as the required report and must be signed in accordance with TCEQ rules at 30 TAC 305.128.

Corrective Action

Personnel Responsible for Corrective Actions

Both Primary and Secondary Operators are responsible for maintaining all necessary Corrective Actions. If an individual is specifically identified as the responsible party for modifying the contact information for that individual should be documented in the attached Inspector Qualifications Log.

Corrective Action Forms

The Temporary BMPs must be modified based on the results of inspections, as necessary, to better control pollutants in runoff. Revisions must be completed within seven (7) calendar days following the inspection. If existing BMPs are modified or if additional BMPs are necessary, an implementation schedule must be described in the attached forms and wherever possible those changes implemented before the next storm event. If implementation before the next anticipated storm event is impracticable, these changes must be implemented as soon as practicable. Actions taken as a result of inspections must be properly documented by completing the corrective action forms given.



Inspector Qualifications Log*

Inspector Name: _____
Qualifications (Check as appropriate and provide description):
 Training Course _____
 Supervised Experience _____
 Other _____

Inspector Name: _____
Qualifications (Check as appropriate and provide description):
 Training Course _____
 Supervised Experience _____
 Other _____

Inspector Name: _____
Qualifications (Check as appropriate and provide description):
 Training Course _____
 Supervised Experience _____
 Other _____

Inspector Name: _____
Qualifications (Check as appropriate and provide description):
 Training Course _____
 Supervised Experience _____
 Other _____

Inspector Name: _____
Qualifications (Check as appropriate and provide description):
 Training Course _____
 Supervised Experience _____
 Other _____

Inspector Name: _____
Qualifications (Check as appropriate and provide description):
 Training Course _____
 Supervised Experience _____
 Other _____

*The agent that performs the inspections should be knowledgeable of this general permit, familiar with the construction site, and knowledgeable of the SWPPP for the site. The contractor is to provide an inspector with a CPESC, CESSWI, or CISEC certification.



Condition and Effectiveness of Erosion and Sediment (E&S) Controls				
Type / Location of E&S Control	Repairs or Other Maintenance Needed?	Corrective Action Required?	Date on Which Maintenance of Corrective Action First Identified?	Notes
1.	<input type="checkbox"/> Yes <input type="checkbox"/> No	<input type="checkbox"/> Yes <input type="checkbox"/> No		
2.	<input type="checkbox"/> Yes <input type="checkbox"/> No	<input type="checkbox"/> Yes <input type="checkbox"/> No		
3.	<input type="checkbox"/> Yes <input type="checkbox"/> No	<input type="checkbox"/> Yes <input type="checkbox"/> No		
4.	<input type="checkbox"/> Yes <input type="checkbox"/> No	<input type="checkbox"/> Yes <input type="checkbox"/> No		
5.	<input type="checkbox"/> Yes <input type="checkbox"/> No	<input type="checkbox"/> Yes <input type="checkbox"/> No		
6.	<input type="checkbox"/> Yes <input type="checkbox"/> No	<input type="checkbox"/> Yes <input type="checkbox"/> No		
7.	<input type="checkbox"/> Yes <input type="checkbox"/> No	<input type="checkbox"/> Yes <input type="checkbox"/> No		
8.	<input type="checkbox"/> Yes <input type="checkbox"/> No	<input type="checkbox"/> Yes <input type="checkbox"/> No		
9.	<input type="checkbox"/> Yes <input type="checkbox"/> No	<input type="checkbox"/> Yes <input type="checkbox"/> No		



Condition and Effectiveness of Pollution Prevention (P ₂) Practices				
Type / Location of P ₂ Practices	Repairs or Other Maintenance Needed?	Corrective Action Required?	Identification Date	Notes
1.	<input type="checkbox"/> Yes <input type="checkbox"/> No	<input type="checkbox"/> Yes <input type="checkbox"/> No		
2.	<input type="checkbox"/> Yes <input type="checkbox"/> No	<input type="checkbox"/> Yes <input type="checkbox"/> No		
3.	<input type="checkbox"/> Yes <input type="checkbox"/> No	<input type="checkbox"/> Yes <input type="checkbox"/> No		
4.	<input type="checkbox"/> Yes <input type="checkbox"/> No	<input type="checkbox"/> Yes <input type="checkbox"/> No		
5.	<input type="checkbox"/> Yes <input type="checkbox"/> No	<input type="checkbox"/> Yes <input type="checkbox"/> No		
6.	<input type="checkbox"/> Yes <input type="checkbox"/> No	<input type="checkbox"/> Yes <input type="checkbox"/> No		
7.	<input type="checkbox"/> Yes <input type="checkbox"/> No	<input type="checkbox"/> Yes <input type="checkbox"/> No		
8.	<input type="checkbox"/> Yes <input type="checkbox"/> No	<input type="checkbox"/> Yes <input type="checkbox"/> No		
9.	<input type="checkbox"/> Yes <input type="checkbox"/> No	<input type="checkbox"/> Yes <input type="checkbox"/> No		



Stabilization of Exposed Soil			
Stabilization Area	Stabilization Method	Have you Initiated Stabilization?	Notes
1.		<input type="checkbox"/> YES <input type="checkbox"/> NO If yes, provide date:	
2.		<input type="checkbox"/> YES <input type="checkbox"/> NO If yes, provide date:	
3.		<input type="checkbox"/> YES <input type="checkbox"/> NO If yes, provide date:	
4.		<input type="checkbox"/> YES <input type="checkbox"/> NO If yes, provide date:	
Description of Discharges			
Was a stormwater discharge or other discharge occurring from any part of your site at the time of the inspection? <input type="checkbox"/> YES <input type="checkbox"/> NO If "YES," provide the following information for each point of discharge:			
Discharge Locations	Observations		
1.	Describe the discharge: At points of discharge and the channels and banks of surface waters in the immediate vicinity, are there any visible signs of erosion and / or sediment accumulation that can be attributed to your discharge? <input type="checkbox"/> YES. <input type="checkbox"/> NO If yes, describe what you see, specify the location(s) where these conditions were found, and indicate whether modification, maintenance, or corrective action is needed to resolve the issue:		
2.	Describe the discharge: At points of discharge and the channels and banks of surface waters in the immediate vicinity, are there any visible signs of erosion and / or sediment accumulation that can be attributed to your discharge? <input type="checkbox"/> YES. <input type="checkbox"/> NO If yes, describe what you see, specify the location(s) where these conditions were found, and indicate whether modification, maintenance, or corrective action is needed to resolve the issue:		
3.	Describe the discharge: At points of discharge and the channels and banks of surface waters in the immediate vicinity, are there any visible signs of erosion and / or sediment accumulation that can be attributed to your discharge? <input type="checkbox"/> YES. <input type="checkbox"/> NO If yes, describe what you see, specify the location(s) where these conditions were found, and indicate whether modification, maintenance, or corrective action is needed to resolve the issue:		



Contractor or Subcontractor Certification and Signature

“I certify under penalty of law that this document and all attachments were prepared under my direction or supervision in accordance with a system designed to assure that qualified personnel properly gathered and evaluated the information, submitted. Based on my inquiry of the person or persons who manage the system, or those persons directly responsible for gathering the information, the information submitted is, to the best of my knowledge and belief, true, accurate, and complete. I am, aware that there are significant penalties for submitting false information, including the possibility of fine and imprisonment for knowing violations.”

Signature of Contractor or Subcontractor: _____ **Date:** _____

Printed Name and Affiliation:

Certification and Signature by Permittee

“I certify under penalty of law that this document and all attachments were prepared under my direction or supervision in accordance with a system designed to assure that qualified personnel properly gathered and evaluated the information, submitted. Based on my inquiry of the person or persons who manage the system, or those persons directly responsible for gathering the information, the information submitted is, to the best of my knowledge and belief, true, accurate, and complete. I am, aware that there are significant penalties for submitting false information, including the possibility of fine and imprisonment for knowing violations.”

Signature of Permittee or
“Duly Authorized Representative”: _____ **Date:** _____

Printed Name and Affiliation:



Section A – Initial Report			
(Complete this section within 24 hours of discovering the condition that triggered corrective action.)			
Name of Project:	Tracking Number:	Today's Date	
Date Problem First Discovered:	Time Problem First Discovered:		
Name of Individual Completing this Form:	Contact Information:		
<p>What site conditions triggered the requirement to conduct corrective action:</p> <p><input type="checkbox"/> A required stormwater control was never installed, was installed incorrectly, or not in accordance with the requirements in Part 2 and/or Part 3</p> <p><input type="checkbox"/> The stormwater controls that have been installed and maintained are not effective enough for the discharge to meet applicable water quality standards</p> <p><input type="checkbox"/> A prohibited discharge has occurred or is occurring</p> <p>Provide a description of the problem:</p> <p>Deadline for completing corrective action (Enter date that is either: (1) no more than 7 calendar days after the date you discovered the problem, or (2) if it is infeasible to complete work within the first 7 days, enter the date that is as soon as practicable following the 7th day):</p> <p>If your estimated date of completion falls after the 7-day deadline, explain (1) why you believe it is infeasible to complete work within 7 days, and (2) why the date you have established for making the new or modified stormwater control operational is the soonest practicable timeframe:</p>			
Section B – Corrective Action Progress			
(Complete this section no later than 7 calendar days after discovering the condition that triggered corrective action.)			
Section B.1 – Why the Problem Occurred			
Cause(s) of Problem (Add an additional sheet if necessary)	How This Was Determined and the Date You Determined the Cause		
1.	1.		
2.	2.		
Section B.2 – Stormwater Control Modifications to be Implemented to Correct the Problem			
List of Stormwater control Modification(s) Needed to Correct Problem (Add an additional sheet if necessary)	Completion Date	SWPPP Update Necessary?	Notes
1.		<input type="checkbox"/> Yes <input type="checkbox"/> No Date:	
2.		<input type="checkbox"/> Yes <input type="checkbox"/> No Date:	



Section A – Initial Report (Complete this section within 24 hours of discovering the condition that triggered corrective action.)			
Name of Project:	Tracking Number:	Today's Date	
Date Problem First Discovered:	Time Problem First Discovered:		
Name of Individual Completing this Form:	Contact Information:		
<p>What site conditions triggered the requirement to conduct corrective action:</p> <p><input type="checkbox"/> A required stormwater control was never installed, was installed incorrectly, or not in accordance with the requirements in Part 2 and/or Part 3</p> <p><input type="checkbox"/> The stormwater controls that have been installed and maintained are not effective enough for the discharge to meet applicable water quality standards</p> <p><input type="checkbox"/> A prohibited discharge has occurred or is occurring</p> <p>Provide a description of the problem:</p> <p>Deadline for completing corrective action (Enter date that is either: (1) no more than 7 calendar days after the date you discovered the problem, or (2) if it is infeasible to complete work within the first 7 days, enter the date that is as soon as practicable following the 7th day):</p> <p>If your estimated date of completion falls after the 7-day deadline, explain (1) why you believe it is infeasible to complete work within 7 days, and (2) why the date you have established for making the new or modified stormwater control operational is the soonest practicable timeframe:</p>			
Section B – Corrective Action Progress (Complete this section no later than 7 calendar days after discovering the condition that triggered corrective action.)			
Section B.1 – Why the Problem Occurred			
Cause(s) of Problem (Add an additional sheet if necessary)	How This Was Determined and the Date You Determined the Cause		
1.	1.		
2.	2.		
Section B.2 – Stormwater Control Modifications to be Implemented to Correct the Problem			
List of Stormwater control Modification(s) Needed to Correct Problem (Add an additional sheet if necessary)	Completion Date	SWPPP Update Necessary?	Notes
1.		<input type="checkbox"/> Yes <input type="checkbox"/> No Date:	
2.		<input type="checkbox"/> Yes <input type="checkbox"/> No Date:	

Contractor or Subcontractor Certification and Signature
--



“I certify under penalty of law that this document and all attachments were prepared under my direction or supervision in accordance with a system designed to assure that qualified personnel properly gathered and evaluated the information, submitted. Based on my inquiry of the person or persons who manage the system, or those persons directly responsible for gathering the information, the information submitted is, to the best of my knowledge and belief, true, accurate, and complete. I am, aware that there are significant penalties for submitting false information, including the possibility of fine and imprisonment for knowing violations.”

Signature of Contractor or Subcontractor: _____ **Date:** _____

Printed Name and Affiliation:

Certification and Signature by Permittee

“I certify under penalty of law that this document and all attachments were prepared under my direction or supervision in accordance with a system designed to assure that qualified personnel properly gathered and evaluated the information, submitted. Based on my inquiry of the person or persons who manage the system, or those persons directly responsible for gathering the information, the information submitted is, to the best of my knowledge and belief, true, accurate, and complete. I am, aware that there are significant penalties for submitting false information, including the possibility of fine and imprisonment for knowing violations.”

Signature of Permittee or
“Duly Authorized Representative”: _____ **Date:** _____

Printed Name and Affiliation:



Temporary Stormwater Section (TCEQ-0602)

Attachment J: Schedule of Interim and Permanent Soil Stabilization Practices

Interim Vegetative Stabilization

Interim soil stabilization will not be required.

Permanent Vegetative Stabilization

Construction practices shall disturb the minimal amount of existing ground cover as required for land clearing, grading, and construction activity for the shortest amount of time possible to minimize the potential of erosion and sedimentation from the site. Existing vegetation shall be maintained and left in place until it is necessary to disturb construction activity. For this project, the following stabilization practices will be implemented:

1. Hydraulic Mulch and Seeding: Disturbed areas subject to erosion shall be stabilized with hydraulic mulch and/or seeded and watered to provide interim stabilization.
2. Sodding and Wood Mulch: As per the project landscaping plan, sodding and wood mulch will be applied to landscaped areas to provide permanent stabilization prior to project completion.

Records of the following shall be maintained:

1. The dates when major grading activities occur,
2. The dates when construction activities temporarily or permanently cease on a portion of the site, and
3. The dates when stabilization measures are initiated.

Stabilization measures must be initiated as soon as practical in portions of the site where construction activities have temporarily or permanently ceased, and except as provided in the following, must be initiated no more than fourteen (14) days after the construction activity in that portion of the site has temporarily or permanently ceased:

Where the initiation of stabilization measures by the 14th day after construction activity temporarily or permanently ceased is precluded by snow cover or frozen ground conditions, stabilization measures must be initiated as soon as practical.



PROJECT NAME
CONTRIBUTING ZONE PLAN
Month, Day, Year

Where construction activity on a portion of the site is temporarily ceased and earth disturbing activities will be resumed within twenty-one (21) days, temporary stabilization measures do not have to be initiated on that portion of the site.

In arid areas (areas with an average rainfall of 0-10 inches), semiarid areas (areas with an average annual rainfall of 10 to 20 inches), and areas experiencing droughts where the initiation of stabilization measures by the 14th day after construction activity has temporarily or permanently ceased is precluded by seasonably arid conditions, stabilization measures must be initiated as soon as practical.



PROJECT NAME
CONTRIBUTING ZONE PLAN
Month, Day, Year

Copy of Notice of Intent (NOI)



PROJECT NAME
CONTRIBUTING ZONE PLAN
Month, Day, Year

Agent Authorization Form (TCEQ-0599)

SIGNATURE PAGE:

Applicant's Signature

Bud Allora
3-26-2024
Date

THE STATE OF Texas §

County of Blairstown §

BEFORE ME, the undersigned authority, on this day personally appeared Bud Allora known to me to be the person whose name is subscribed to the foregoing instrument, and acknowledged to me that (s)he executed same for the purpose and consideration therein expressed.

GIVEN under my hand and seal of office on this 26 day of March, 2024.

Christina Gonzales
NOTARY PUBLIC

Christina Gonzales
Typed or Printed Name of Notary

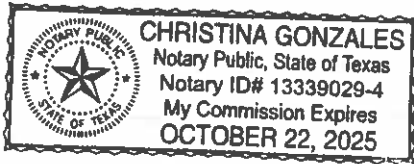

MY COMMISSION EXPIRES: 10/22/2025



PROJECT NAME
CONTRIBUTING ZONE PLAN
Month, Day, Year

Application Fee Form (TCEQ-0574)

Application Fee Form

Texas Commission on Environmental Quality

Name of Proposed Regulated Entity: PEC Liberty Hill

Regulated Entity Location: 10625 W SH 29, Liberty Hill, TX 78642

Name of Customer: Pedernales Electric Cooperative, Inc.

Contact Person: Bud Collora

Phone: 830-868-6056

Customer Reference Number (if issued): CN 601327927

Regulated Entity Reference Number (if issued): RN 105473979

Austin Regional Office (3373)

Hays

Travis

Williamson

San Antonio Regional Office (3362)

Bexar

Medina

Uvalde

Comal

Kinney

Application fees must be paid by check, certified check, or money order, payable to the **Texas Commission on Environmental Quality**. Your canceled check will serve as your receipt. **This form must be submitted with your fee payment.** This payment is being submitted to:

Austin Regional Office

San Antonio Regional Office

Mailed to: TCEQ - Cashier

Overnight Delivery to: TCEQ - Cashier

Revenues Section

Mail Code 214

P.O. Box 13088

Austin, TX 78711-3088

12100 Park 35 Circle

Building A, 3rd Floor

Austin, TX 78753

(512)239-0357

Site Location (Check All That Apply):

Recharge Zone

Contributing Zone

Transition Zone

<i>Type of Plan</i>	<i>Size</i>	<i>Fee Due</i>
Water Pollution Abatement Plan, Contributing Zone Plan: One Single Family Residential Dwelling	Acres	\$
Water Pollution Abatement Plan, Contributing Zone Plan: Multiple Single Family Residential and Parks	Acres	\$
Water Pollution Abatement Plan, Contributing Zone Plan: Non-residential	6.22 Acres	\$ 5,000
Sewage Collection System	L.F.	\$
Lift Stations without sewer lines	Acres	\$
Underground or Aboveground Storage Tank Facility	Tanks	\$
Piping System(s)(only)	Each	\$
Exception	Each	\$
Extension of Time	Each	\$

Signature: 

Date: 3/20/2024

Application Fee Schedule

Texas Commission on Environmental Quality

Edwards Aquifer Protection Program 30 TAC Chapter 213 (effective 05/01/2008)

Water Pollution Abatement Plans and Modifications

Contributing Zone Plans and Modifications

<i>Project</i>	<i>Project Area in Acres</i>	<i>Fee</i>
One Single Family Residential Dwelling	< 5	\$650
Multiple Single Family Residential and Parks	< 5	\$1,500
	5 < 10	\$3,000
	10 < 40	\$4,000
	40 < 100	\$6,500
	100 < 500	\$8,000
	≥ 500	\$10,000
Non-residential (Commercial, industrial, institutional, multi-family residential, schools, and other sites where regulated activities will occur)	< 1	\$3,000
	1 < 5	\$4,000
	5 < 10	\$5,000
	10 < 40	\$6,500
	40 < 100	\$8,000
	≥ 100	\$10,000

Organized Sewage Collection Systems and Modifications

<i>Project</i>	<i>Cost per Linear Foot</i>	<i>Minimum Fee- Maximum Fee</i>
Sewage Collection Systems	\$0.50	\$650 - \$6,500

Underground and Aboveground Storage Tank System Facility Plans and Modifications

<i>Project</i>	<i>Cost per Tank or Piping System</i>	<i>Minimum Fee- Maximum Fee</i>
Underground and Aboveground Storage Tank Facility	\$650	\$650 - \$6,500

Exception Requests

<i>Project</i>	<i>Fee</i>
Exception Request	\$500

Extension of Time Requests

<i>Project</i>	<i>Fee</i>
Extension of Time Request	\$150



PROJECT NAME
CONTRIBUTING ZONE PLAN
Month, Day, Year

**Check Payable to the “Texas Commission on Environmental
Quality”**



PROJECT NAME
CONTRIBUTING ZONE PLAN
Month, Day, Year

Core Data Form (TCEQ-10400)



TCEQ Core Data Form

For detailed instructions on completing this form, please read the Core Data Form Instructions or call 512-239-5175.

SECTION I: General Information

1. Reason for Submission (If other is checked please describe in space provided.)		
<input type="checkbox"/> New Permit, Registration or Authorization (Core Data Form should be submitted with the program application.)		
<input checked="" type="checkbox"/> Renewal (Core Data Form should be submitted with the renewal form)	<input type="checkbox"/> Other	
2. Customer Reference Number (if issued)	Follow this link to search for CN or RN numbers in Central Registry**	3. Regulated Entity Reference Number (if issued)
CN 601327927		RN 105473979

SECTION II: Customer Information

4. General Customer Information		5. Effective Date for Customer Information Updates (mm/dd/yyyy)		
<input type="checkbox"/> New Customer <input checked="" type="checkbox"/> Update to Customer Information <input type="checkbox"/> Change in Regulated Entity Ownership <input type="checkbox"/> Change in Legal Name (Verifiable with the Texas Secretary of State or Texas Comptroller of Public Accounts)				
<i>The Customer Name submitted here may be updated automatically based on what is current and active with the Texas Secretary of State (SOS) or Texas Comptroller of Public Accounts (CPA).</i>				
6. Customer Legal Name (If an individual, print last name first: eg: Doe, John)			<i>If new Customer, enter previous Customer below:</i>	
PEDERNALES ELECTRIC COOPERATIVE INC				
7. TX SOS/CPA Filing Number	8. TX State Tax ID (11 digits)		9. Federal Tax ID	10. DUNS Number (if applicable)
0007336401	17408284127		(9 digits)	
11. Type of Customer:	<input checked="" type="checkbox"/> Corporation		<input type="checkbox"/> Individual	Partnership: <input type="checkbox"/> General <input type="checkbox"/> Limited
Government: <input type="checkbox"/> City <input type="checkbox"/> County <input type="checkbox"/> Federal <input type="checkbox"/> Local <input type="checkbox"/> State <input type="checkbox"/> Other			<input type="checkbox"/> Sole Proprietorship	<input type="checkbox"/> Other:
12. Number of Employees			13. Independently Owned and Operated?	
<input type="checkbox"/> 0-20 <input type="checkbox"/> 21-100 <input checked="" type="checkbox"/> 101-250 <input type="checkbox"/> 251-500 <input type="checkbox"/> 501 and higher			<input checked="" type="checkbox"/> Yes <input type="checkbox"/> No	
14. Customer Role (Proposed or Actual) – as it relates to the Regulated Entity listed on this form. Please check one of the following				
<input type="checkbox"/> Owner <input type="checkbox"/> Operator <input checked="" type="checkbox"/> Owner & Operator <input type="checkbox"/> Other: <input type="checkbox"/> Occupational Licensee <input type="checkbox"/> Responsible Party <input type="checkbox"/> VCP/BSA Applicant				
15. Mailing Address:	P.O. BOX 1			
	City	Johnson City	State	TX
	ZIP	78636	ZIP + 4	
16. Country Mailing Information (if outside USA)			17. E-Mail Address (if applicable)	
18. Telephone Number		19. Extension or Code		20. Fax Number (if applicable)

SECTION III: Regulated Entity Information

21. General Regulated Entity Information <i>(If 'New Regulated Entity' is selected, a new permit application is also required.)</i>							
<input type="checkbox"/> New Regulated Entity <input type="checkbox"/> Update to Regulated Entity Name <input checked="" type="checkbox"/> Update to Regulated Entity Information							
<i>The Regulated Entity Name submitted may be updated, in order to meet TCEQ Core Data Standards (removal of organizational endings such as Inc, LP, or LLC).</i>							
22. Regulated Entity Name <i>(Enter name of the site where the regulated action is taking place.)</i>							
PEC Liberty Hill							
23. Street Address of the Regulated Entity: <i>(No PO Boxes)</i>	10625 W SH 29						
	City	Liberty Hill	State	TX	ZIP	78642	ZIP + 4
24. County	Williamson						

If no Street Address is provided, fields 25-28 are required.

25. Description to Physical Location:							
26. Nearest City						State	Nearest ZIP Code
<i>Latitude/Longitude are required and may be added/updated to meet TCEQ Core Data Standards. (Geocoding of the Physical Address may be used to supply coordinates where none have been provided or to gain accuracy).</i>							
27. Latitude (N) In Decimal:	30.649222			28. Longitude (W) In Decimal:	-97.863481		
Degrees	Minutes	Seconds	Degrees	Minutes	Seconds		
30	38	57.20	-97	51	48.53		
29. Primary SIC Code (4 digits)	30. Secondary SIC Code (4 digits)	31. Primary NAICS Code (5 or 6 digits)	32. Secondary NAICS Code (5 or 6 digits)				
4911		221122					
33. What is the Primary Business of this entity? <i>(Do not repeat the SIC or NAICS description.)</i>							
PEC Operations Center							
34. Mailing Address:	P.O. Box 1						
	City	Johnson City	State	TX	ZIP	78636	ZIP + 4
35. E-Mail Address:							
36. Telephone Number	37. Extension or Code			38. Fax Number <i>(if applicable)</i>			
() -				() -			

39. TCEQ Programs and ID Numbers Check all Programs and write in the permits/registration numbers that will be affected by the updates submitted on this form. See the Core Data Form instructions for additional guidance.

<input type="checkbox"/> Dam Safety	<input type="checkbox"/> Districts	<input checked="" type="checkbox"/> Edwards Aquifer	<input type="checkbox"/> Emissions Inventory Air	<input type="checkbox"/> Industrial Hazardous Waste
		11-08030503 (4/16/2008) 11001078 (Mod 5/23/2018)		
<input type="checkbox"/> Municipal Solid Waste	<input type="checkbox"/> New Source Review Air	<input type="checkbox"/> OSSF	<input type="checkbox"/> Petroleum Storage Tank	<input type="checkbox"/> PWS
<input type="checkbox"/> Sludge	<input type="checkbox"/> Storm Water	<input type="checkbox"/> Title V Air	<input type="checkbox"/> Tires	<input type="checkbox"/> Used Oil
<input type="checkbox"/> Voluntary Cleanup	<input type="checkbox"/> Wastewater	<input type="checkbox"/> Wastewater Agriculture	<input type="checkbox"/> Water Rights	<input type="checkbox"/> Other:

SECTION IV: Preparer Information

40. Name:	Nick Sandlin, P.E. (Sandlin Services, LLC)	41. Title:	Principal / Professional Engineer
42. Telephone Number	43. Ext./Code	44. Fax Number	45. E-Mail Address
(806) 679-7303		() -	nick@sandlinservices.com

SECTION V: Authorized Signature

46. By my signature below, I certify, to the best of my knowledge, that the information provided in this form is true and complete, and that I have signature authority to submit this form on behalf of the entity specified in Section II, Field 6 and/or as required for the updates to the ID numbers identified in field 39.

Company:	Sandlin Services, LLC	Job Title:	Principal / Professional Engineer
Name (In Print):	Nick Sandlin, P.E.	Phone:	(806) 679- 7303
Signature:		Date:	3/20/2024