



Water Pollution Abatement Plan

Prepared For: Comal Iron and Metals
1431 FM 603
New Braunfels, Texas 78132

Prepared By: James Environmental Management, Inc.
PO Box 1323
Georgetown, Texas 78627

Preparation Date: September 2022
Revision Date: March 23, 2023

Table of Contents

- Section 1 – Edwards Aquifer Application Cover Page (TCEQ-20705)
- Section 2 – General Information Form (TCEQ-0587)
 - Attachment A – Road Map
 - Attachment B – USGS/Edwards Recharge Zone Map
 - Attachment C – Project Description
- Section 3 – Geologic Assessment Form (TCEQ-0585)
 - Attachment A – Geologic Assessment Table (TCEQ-0585-Table)
 - Attachment B – Stratigraphic Column
 - Attachment C – Site Geology
 - Attachment D – Site Geology Map(s)
- Section 4 – Water Pollution Abatement Application Form (TCEQ-0584)
 - Attachment A – Factors Affecting Surface Water Quality
 - Attachment B – Volume and Character of Stormwater
 - Attachment C – Suitability Letter from Authorized Agent
 - Attachment D – Exception to the Required Geologic Assessment
 - Attachment E – Site Plan
- Section 5 – Temporary Stormwater Application (TCEQ-0602)
 - Attachment A – Spill Response Actions
 - Attachment B – Potential Sources of Contamination
 - Attachment C – Sequence of Major Activities
 - Attachment D – Temporary Best Management Practices and Measures
 - Attachment E – Request to Temporarily Seal a Feature
 - Attachment F – Structural Practices
 - Attachment G – Drainage Area Map
 - Attachment H – Temporary Sediment Pond(s) Plans and Calculations
 - Attachment I – Inspection and Maintenance for BMPs
 - Attachment J – Schedule of Interim and Permanent Soil Stabilization Practices
- Section 6 – Permanent Stormwater Section (TCEQ - 0600)
 - Attachment A – 20% or Less Impervious Cover Waiver
 - Attachment B – BMPs for Upgradient Stormwater
 - Attachment C – BMPs for On-site Stormwater
 - Attachment D – BMPs for Surface Streams
 - Attachment E – Request to Seal Features
 - Attachment F – Construction Plans
 - Attachment G – Inspection, Maintenance, Repair and Retrofit Plan
 - Attachment H – Pilot-Scale Field Testing Plan
 - Attachment I – Measures for Minimizing Surface Stream Contamination
- Section 7 – Aboveground Storage Tank Facility Plan Application (TCEQ - 0575)
 - Attachment A – Alternative Methods of Secondary Containment
 - Attachment B – Scaled Drawing(s) of Containment Structure
 - Attachment C – Exception to the Geologic Assessment
 - Attachment D – Spill and Overfill Control
 - Attachment E – Response Actions to Spills
- Section 8 – Agent Authorization Form (TCEQ - 0599) & Property Owner Deed
- Section 9 – Application Fee Form (TCEQ-0574)
- Section 10 – Core Data Form (TCEQ-10400)



Section 1

Comal Iron and Metals – Edwards Aquifer Application Cover Page
(TCEQ-20705)

Texas Commission on Environmental Quality

Edwards Aquifer Application Cover Page

Our Review of Your Application

The Edwards Aquifer Program staff conducts an administrative and technical review of all applications. The turnaround time for administrative review can be up to 30 days as outlined in 30 TAC 213.4(e). Generally administrative completeness is determined during the intake meeting or within a few days of receipt. The turnaround time for technical review of an administratively complete Edwards Aquifer application is 90 days as outlined in 30 TAC 213.4(e). Please know that the review and approval time is directly impacted by the quality and completeness of the initial application that is received. In order to conduct a timely review, it is imperative that the information provided in an Edwards Aquifer application include final plans, be accurate, complete, and in compliance with [30 TAC 213](#).

Administrative Review

1. [Edwards Aquifer applications](#) must be deemed administratively complete before a technical review can begin. To be considered administratively complete, the application must contain completed forms and attachments, provide the requested information, and meet all the site plan requirements. The submitted application and plan sheets should be final plans. Please submit one full-size set of plan sheets with the original application, and half-size sets with the additional copies.

To ensure that all applicable documents are included in the application, the program has developed tools to guide you and web pages to provide all forms, checklists, and guidance. Please visit the below website for assistance: <http://www.tceq.texas.gov/field/eapp>.

2. This Edwards Aquifer Application Cover Page form (certified by the applicant or agent) must be included in the application and brought to the administrative review meeting.
3. Administrative reviews are scheduled with program staff who will conduct the review. Applicants or their authorized agent should call the appropriate regional office, according to the county in which the project is located, to schedule a review. The average meeting time is one hour.
4. In the meeting, the application is examined for administrative completeness. Deficiencies will be noted by staff and emailed or faxed to the applicant and authorized agent at the end of the meeting, or shortly after. Administrative deficiencies will cause the application to be deemed incomplete and returned.

An appointment should be made to resubmit the application. The application is re-examined to ensure all deficiencies are resolved. The application will only be deemed administratively complete when all administrative deficiencies are addressed.

5. If an application is received by mail, courier service, or otherwise submitted without a review meeting, the administrative review will be conducted within 30 days. The applicant and agent will be contacted with the results of the administrative review. If the application is found to be administratively incomplete, it can be retrieved from the regional office or returned by regular mail. If returned by mail, the regional office may require arrangements for return shipping.
6. If the geologic assessment was completed before October 1, 2004 and the site contains “possibly sensitive” features, the assessment must be updated in accordance with the *Instructions to Geologists* (TCEQ-0585 Instructions).

Technical Review

1. When an application is deemed administratively complete, the technical review period begins. The regional office will distribute copies of the application to the identified affected city, county, and groundwater conservation district whose jurisdiction includes the subject site. These entities and the public have 30 days to provide comments on the application to the regional office. All comments received are reviewed by TCEQ.
2. A site assessment is usually conducted as part of the technical review, to evaluate the geologic assessment and observe existing site conditions. The site must be accessible to our staff. The site boundaries should be

clearly marked, features identified in the geologic assessment should be flagged, roadways marked and the alignment of the Sewage Collection System and manholes should be staked at the time the application is submitted. If the site is not marked the application may be returned.

- We evaluate the application for technical completeness and contact the applicant and agent via Notice of Deficiency (NOD) to request additional information and identify technical deficiencies. There are two deficiency response periods available to the applicant. There are 14 days to resolve deficiencies noted in the first NOD. If a second NOD is issued, there is an additional 14 days to resolve deficiencies. If the response to the second notice is not received, is incomplete or inadequate, or provides new information that is incomplete or inadequate, the application must be withdrawn or will be denied. Please note that because the technical review is underway, whether the application is withdrawn or denied **the application fee will be forfeited**.
- The program has 90 calendar days to complete the technical review of the application. If the application is technically adequate, such that it complies with the Edwards Aquifer rules, and is protective of the Edwards Aquifer during and after construction, an approval letter will be issued. Construction or other regulated activity may not begin until an approval is issued.

Mid-Review Modifications

It is important to have final site plans prior to beginning the permitting process with TCEQ to avoid delays.

Occasionally, circumstances arise where you may have significant design and/or site plan changes after your Edwards Aquifer application has been deemed administratively complete by TCEQ. This is considered a “Mid-Review Modification”. Mid-Review Modifications may require redistribution of an application that includes the proposed modifications for public comment.

If you are proposing a Mid-Review Modification, two options are available:

- If the technical review has begun your application can be denied/withdrawn, your fees will be forfeited, and the plan will have to be resubmitted.
- TCEQ can continue the technical review of the application as it was submitted, and a modification application can be submitted at a later time.

If the application is denied/withdrawn, the resubmitted application will be subject to the administrative and technical review processes and will be treated as a new application. The application will be redistributed to the affected jurisdictions.

Please contact the regional office if you have questions. If your project is located in Williamson, Travis, or Hays County, contact TCEQ’s Austin Regional Office at 512-339-2929. If your project is in Comal, Bexar, Medina, Uvalde, or Kinney County, contact TCEQ’s San Antonio Regional Office at 210-490-3096

Please fill out all required fields below and submit with your application.

1. Regulated Entity Name: Comal Iron and Metals				2. Regulated Entity No.: 103219572					
3. Customer Name: Comal Iron and Metals				4. Customer No.: 600530208					
5. Project Type: (Please circle/check one)	<input checked="" type="radio"/> New	Modification		Extension	Exception				
6. Plan Type: (Please circle/check one)	<input checked="" type="radio"/> WPAI	<input type="radio"/> CZP	<input type="radio"/> SCS	<input type="radio"/> UST	<input checked="" type="radio"/> AST	<input type="radio"/> EXP	<input type="radio"/> EXT	Technical Clarification	Optional Enhanced Measures
7. Land Use: (Please circle/check one)	<input type="radio"/> Residential		<input checked="" type="radio"/> Non-residential		8. Site (acres):		4.3		
9. Application Fee:	\$5,950		10. Permanent BMP(s):			_____			
11. SCS (Linear Ft.):	—		12. AST/UST (No. Tanks):			1 tank, 2 totes, 2 drums			
13. County:	Comal		14. Watershed:			Guadalupe River			

Application Distribution

Instructions: Use the table below to determine the number of applications required. One original and one copy of the application, plus additional copies (as needed) for each affected incorporated city, county, and groundwater conservation district are required. Linear projects or large projects, which cross into multiple jurisdictions, can require additional copies. Refer to the “Texas Groundwater Conservation Districts within the EAPP Boundaries” map found at:

http://www.tceq.texas.gov/assets/public/compliance/field_ops/eapp/EAPP%20GWCD%20map.pdf

For more detailed boundaries, please contact the conservation district directly.

Austin Region			
County:	Hays	Travis	Williamson
Original (1 req.)	—	—	—
Region (1 req.)	—	—	—
County(ies)	—	—	—
Groundwater Conservation District(s)	<input type="checkbox"/> Edwards Aquifer Authority <input type="checkbox"/> Barton Springs/ Edwards Aquifer <input type="checkbox"/> Hays Trinity <input type="checkbox"/> Plum Creek	<input type="checkbox"/> Barton Springs/ Edwards Aquifer	NA
City(ies) Jurisdiction	<input type="checkbox"/> Austin <input type="checkbox"/> Buda <input type="checkbox"/> Dripping Springs <input type="checkbox"/> Kyle <input type="checkbox"/> Mountain City <input type="checkbox"/> San Marcos <input type="checkbox"/> Wimberley <input type="checkbox"/> Woodcreek	<input type="checkbox"/> Austin <input type="checkbox"/> Bee Cave <input type="checkbox"/> Pflugerville <input type="checkbox"/> Rollingwood <input type="checkbox"/> Round Rock <input type="checkbox"/> Sunset Valley <input type="checkbox"/> West Lake Hills	<input type="checkbox"/> Austin <input type="checkbox"/> Cedar Park <input type="checkbox"/> Florence <input type="checkbox"/> Georgetown <input type="checkbox"/> Jerrell <input type="checkbox"/> Leander <input type="checkbox"/> Liberty Hill <input type="checkbox"/> Pflugerville <input type="checkbox"/> Round Rock

San Antonio Region					
County:	Bexar	Comal	Kinney	Medina	Uvalde
Original (1 req.)	—	—	—	—	—
Region (1 req.)	—	—	—	—	—
County(ies)	—	—	—	—	—
Groundwater Conservation District(s)	<input type="checkbox"/> Edwards Aquifer Authority <input type="checkbox"/> Trinity-Glen Rose	<input checked="" type="checkbox"/> Edwards Aquifer Authority	<input type="checkbox"/> Kinney	<input type="checkbox"/> EAA <input type="checkbox"/> Medina	<input type="checkbox"/> EAA <input type="checkbox"/> Uvalde
City(ies) Jurisdiction	<input type="checkbox"/> Castle Hills <input type="checkbox"/> Fair Oaks Ranch <input type="checkbox"/> Helotes <input type="checkbox"/> Hill Country Village <input type="checkbox"/> Hollywood Park <input type="checkbox"/> San Antonio (SAWS) <input type="checkbox"/> Shavano Park	<input type="checkbox"/> Bulverde <input type="checkbox"/> Fair Oaks Ranch <input type="checkbox"/> Garden Ridge <input checked="" type="checkbox"/> New Braunfels <input type="checkbox"/> Schertz	NA	<input type="checkbox"/> San Antonio ETJ (SAWS)	NA

I certify that to the best of my knowledge, that the application is complete and accurate. This application is hereby submitted to TCEQ for administrative review and technical review.

Adriana Lee

Print Name of Customer/Authorized Agent

10/11/2022

Adriana Lee

Signature of Customer/Authorized Agent

Date

****FOR TCEQ INTERNAL USE ONLY****

Date(s) Reviewed:		Date Administratively Complete:	
Received From:		Correct Number of Copies:	
Received By:		Distribution Date:	
EAPP File Number:		Complex:	
Admin. Review(s) (No.):		No. AR Rounds:	
Delinquent Fees (Y/N):		Review Time Spent:	
Lat./Long. Verified:		SOS Customer Verification:	
Agent Authorization Complete/Notarized (Y/N):		Fee Check:	Payable to TCEQ (Y/N):
Core Data Form Complete (Y/N):			Signed (Y/N):
Core Data Form Incomplete Nos.:			Less than 90 days old (Y/N):



Section 2

Comal Iron and Metals – General Information Form (TCEQ-0587)

General Information Form

Texas Commission on Environmental Quality

For Regulated Activities on the Edwards Aquifer Recharge and Transition Zones and Relating to 30 TAC §213.4(b) & §213.5(b)(2)(A), (B) Effective June 1, 1999

To ensure that the application is administratively complete, confirm that all fields in the form are complete, verify that all requested information is provided, consistently reference the same site and contact person in all forms in the application, and ensure forms are signed by the appropriate party.

Note: Including all the information requested in the form and attachments contributes to more streamlined technical reviews.

Signature

To the best of my knowledge, the responses to this form accurately reflect all information requested concerning the proposed regulated activities and methods to protect the Edwards Aquifer. This **General Information Form** is hereby submitted for TCEQ review. The application was prepared by: Comal Iron and Metals

Print Name of Customer/Agent: Comal Iron and Metals/Adriana Lee

Date: 10/11/2022

Signature of Customer/Agent:

AL Lee

Project Information

1. Regulated Entity Name: Comal Iron and Metals

2. County: Comal

3. Stream Basin: Guadalupe River Basin

4. Groundwater Conservation District (If applicable): _____

5. Edwards Aquifer Zone:

- Recharge Zone
 Transition Zone

6. Plan Type:

- | | |
|--|--|
| <input checked="" type="checkbox"/> WPAP | <input checked="" type="checkbox"/> AST |
| <input type="checkbox"/> SCS | <input type="checkbox"/> UST |
| <input type="checkbox"/> Modification | <input type="checkbox"/> Exception Request |

7. Customer (Applicant):

Contact Person: Johnnie Rodriguez Jr.

Entity: Comal Iron and Metals

Mailing Address: 1431 FM 306

City, State: New Braunfels, Texas

Zip: 78132

Telephone: 830-625-4920

FAX: _____

Email Address: safety@comalironandmetals.com

8. Agent/Representative (If any):

Contact Person: Adriana Lee

Entity: James Environmental Management, Inc.

Mailing Address: PO Box 1323

City, State: Georgetown, Texas

Zip: 78627

Telephone: 512-244-3631

FAX: 512-244-0583

Email Address: info@jamesenvironmental.com

9. Project Location:

The project site is located inside the city limits of New Braunfels.

The project site is located outside the city limits but inside the ETJ (extra-territorial jurisdiction) of _____.

The project site is not located within any city's limits or ETJ.

10. The location of the project site is described below. The description provides sufficient detail and clarity so that the TCEQ's Regional staff can easily locate the project and site boundaries for a field investigation.

1431 FM 306, New Braunfels, Texas 78132

11. **Attachment A – Road Map.** A road map showing directions to and the location of the project site is attached. The project location and site boundaries are clearly shown on the map.

12. **Attachment B - USGS / Edwards Recharge Zone Map.** A copy of the official 7 ½ minute USGS Quadrangle Map (Scale: 1" = 2000') of the Edwards Recharge Zone is attached. The map(s) clearly show:

Project site boundaries.

USGS Quadrangle Name(s).

Boundaries of the Recharge Zone (and Transition Zone, if applicable).

Drainage path from the project site to the boundary of the Recharge Zone.

13. **The TCEQ must be able to inspect the project site or the application will be returned.** Sufficient survey staking is provided on the project to allow TCEQ regional staff to locate the boundaries and alignment of the regulated activities and the geologic or manmade features noted in the Geologic Assessment.

Survey staking will be completed by this date: October 24, 2022

14. **Attachment C – Project Description.** Attached at the end of this form is a detailed narrative description of the proposed project. The project description is consistent throughout the application and contains, at a minimum, the following details:

- Area of the site
- Offsite areas
- Impervious cover
- Permanent BMP(s)
- Proposed site use
- Site history
- Previous development
- Area(s) to be demolished

15. Existing project site conditions are noted below:

- Existing commercial site
- Existing industrial site
- Existing residential site
- Existing paved and/or unpaved roads
- Undeveloped (Cleared)
- Undeveloped (Undisturbed/Uncleared)
- Other: _____

Prohibited Activities

16. I am aware that the following activities are prohibited on the Recharge Zone and are not proposed for this project:

- (1) Waste disposal wells regulated under 30 TAC Chapter 331 of this title (relating to Underground Injection Control);
- (2) New feedlot/concentrated animal feeding operations, as defined in 30 TAC §213.3;
- (3) Land disposal of Class I wastes, as defined in 30 TAC §335.1;
- (4) The use of sewage holding tanks as parts of organized collection systems; and
- (5) New municipal solid waste landfill facilities required to meet and comply with Type I standards which are defined in §330.41(b), (c), and (d) of this title (relating to Types of Municipal Solid Waste Facilities).
- (6) New municipal and industrial wastewater discharges into or adjacent to water in the state that would create additional pollutant loading.

17. I am aware that the following activities are prohibited on the Transition Zone and are not proposed for this project:

- (1) Waste disposal wells regulated under 30 TAC Chapter 331 (relating to Underground Injection Control);
- (2) Land disposal of Class I wastes, as defined in 30 TAC §335.1; and

- (3) New municipal solid waste landfill facilities required to meet and comply with Type I standards which are defined in §330.41 (b), (c), and (d) of this title.

Administrative Information

18. The fee for the plan(s) is based on:

- For a Water Pollution Abatement Plan or Modification, the total acreage of the site where regulated activities will occur.
 - For an Organized Sewage Collection System Plan or Modification, the total linear footage of all collection system lines.
 - For a UST Facility Plan or Modification or an AST Facility Plan or Modification, the total number of tanks or piping systems.
 - A request for an exception to any substantive portion of the regulations related to the protection of water quality.
 - A request for an extension to a previously approved plan.
19. Application fees are due and payable at the time the application is filed. If the correct fee is not submitted, the TCEQ is not required to consider the application until the correct fee is submitted. Both the fee and the Edwards Aquifer Fee Form have been sent to the Commission's:
- TCEQ cashier
 - Austin Regional Office (for projects in Hays, Travis, and Williamson Counties)
 - San Antonio Regional Office (for projects in Bexar, Comal, Kinney, Medina, and Uvalde Counties)
20. Submit one (1) original and one (1) copy of the application, plus additional copies as needed for each affected incorporated city, groundwater conservation district, and county in which the project will be located. The TCEQ will distribute the additional copies to these jurisdictions. The copies must be submitted to the appropriate regional office.
21. No person shall commence any regulated activity until the Edwards Aquifer Protection Plan(s) for the activity has been filed with and approved by the Executive Director.



Section 2: General Information Form (TCEQ-0587)

ATTACHMENT A

Comal Iron and Metals – Road Map

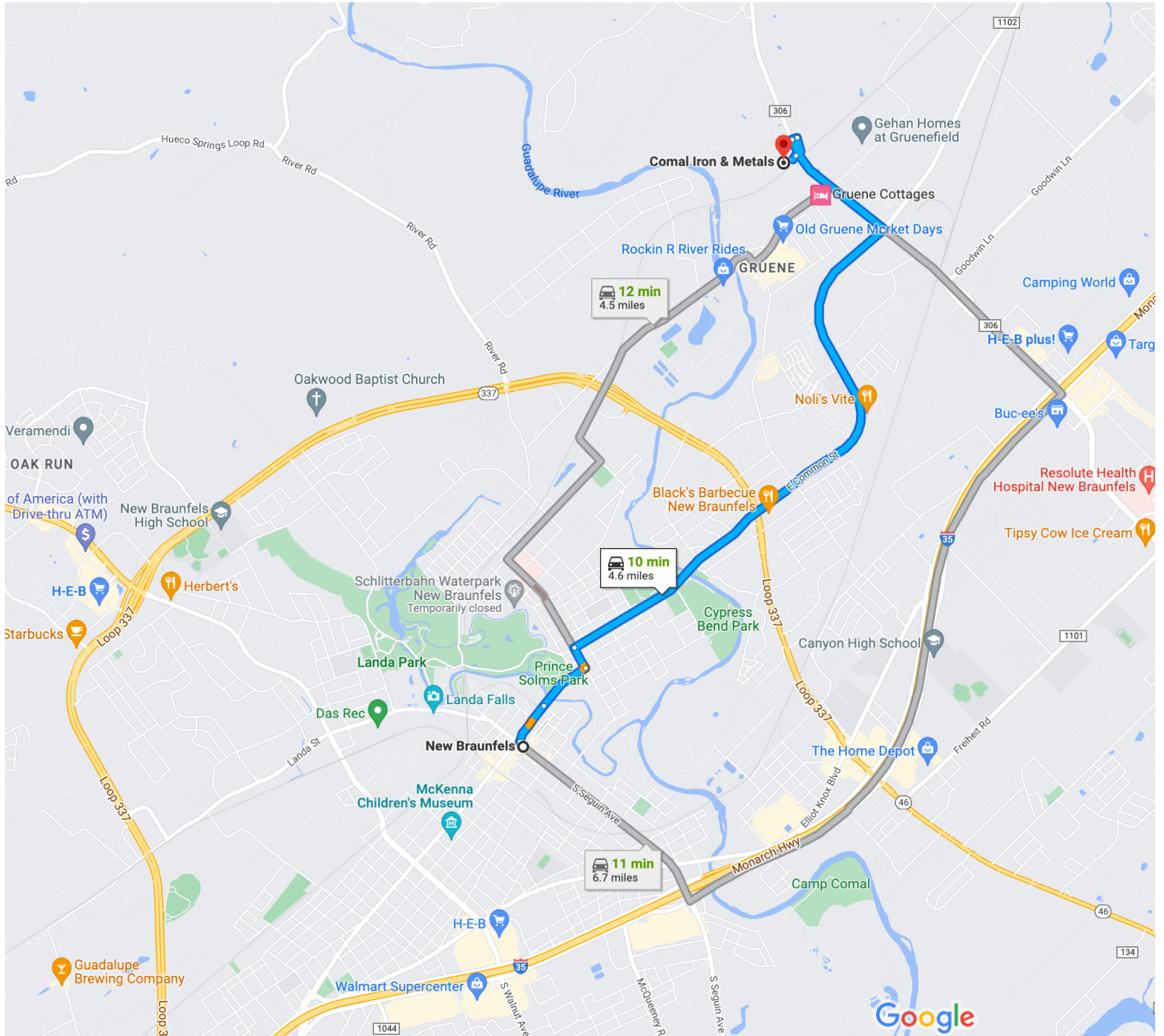

Map data ©2022 2000 ft

New Braunfels
Texas

Drive along Common St

11 min (4.4 mi)

- ↑ 1. Head northwest on S Seguin Ave toward Main Plaza

157 ft

- 🔄 2. At Main Plaza, take the 2nd exit onto E San Antonio St
0.2 mi
📍 [Pass by NAPA Auto Parts - Leissner Auto Parts \(on the right\)](#)
- ↑ 3. Continue straight to stay on E San Antonio St
0.3 mi
- ↶ 4. Turn left onto S Union Ave
0.1 mi
- ↷ 5. Turn right onto Common St
3.1 mi
- ↶ 6. Turn left onto FM306
0.7 mi

Drive to your destination

- 1 min (0.2 mi)
↷ 7. Turn right
135 ft
- ↷ 8. Turn right
0.1 mi
- ↶ 9. Turn left
131 ft

Comal Iron & Metals

1431 FM306, New Braunfels, TX 78132



Section 2: General Information Form (TCEQ-0587)

ATTACHMENT B

Comal Iron and Metals – USGS/Edwards Recharge Zone Map

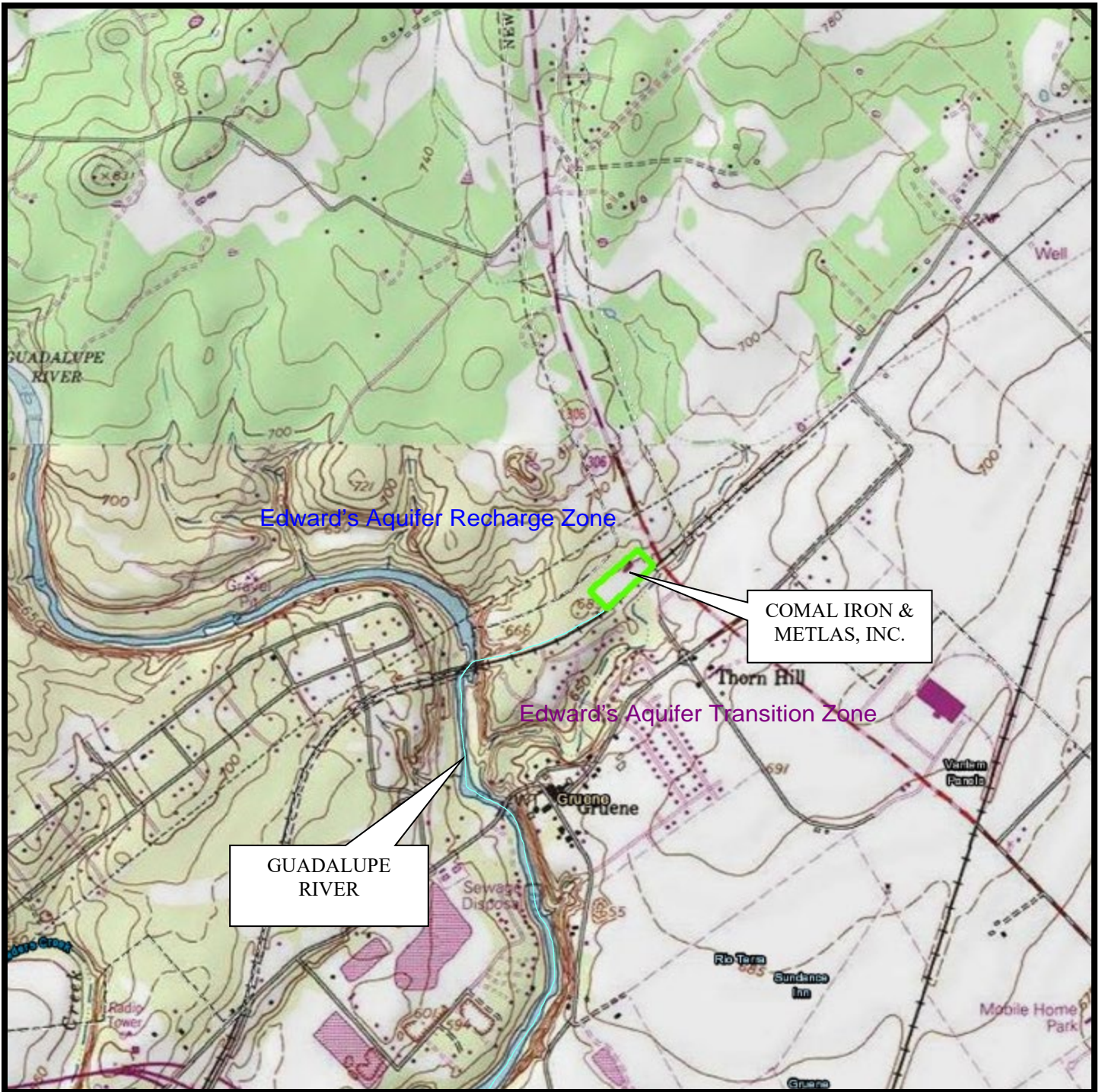

Edward's Aquifer Recharge Zone

COMAL IRON & METLAS, INC.

Edward's Aquifer Transition Zone

GUADALUPE RIVER

SITE LOCATION MAP

USGS Topographic Map

511-777

FIGURE 1

DATE 09/22
MH

James
Environmental
Management, Inc.

GEORGETOWN, TX

COMAL IRON & METALS, INC.

NEW BRAUNFELS, TEXAS

SCALE: 1"=2000'



Section 2: General Information Form (TCEQ-0587)

ATTACHMENT C

Comal Iron and Metals – Project Description

In existing conditions, Comal Iron and Metals (project site) totals 4.3 acres, is completely developed and is located at 1431 FM 306 in the City of New Braunfels, Comal County, Texas 78132. The project site is currently an established metal recycling facility. The project site has one entry point, an office building (~2,240 sq ft), a warehouse (~8,000 sq ft), a maintenance garage (~1,700 sq ft), a covered welding area (~600 sq ft), a covered area for new steel (~2,700 sq ft), and a concrete pad for processing material (~43,764 sq ft). The facility has a vegetated swale with check dams that spans the eastern property fence line and ultimately discharges at outfall 001 on the southern corner of the property. There are no approved permanent BMPs at this time. The proposed permanent BMPs include the installation of a Contech Jellyfish Filter. The project site has been operating as a metal recycling facility since 1972 and will continue to operate as such. Additionally, there are no areas to be built or demolished at this time.



Section 3

Comal Iron and Metals – Geologic Assessment Form (TCEQ-0585)

Geologic Assessment

Texas Commission on Environmental Quality

For Regulated Activities on The Edwards Aquifer Recharge/transition Zones and Relating to 30 TAC §213.5(b)(3), Effective June 1, 1999

To ensure that the application is administratively complete, confirm that all fields in the form are complete, verify that all requested information is provided, consistently reference the same site and contact person in all forms in the application, and ensure forms are signed by the appropriate party.

Note: Including all the information requested in the form and attachments contributes to more streamlined technical reviews.

Signature

To the best of my knowledge, the responses to this form accurately reflect all information requested concerning the proposed regulated activities and methods to protect the Edwards Aquifer. My signature certifies that I am qualified as a geologist as defined by 30 TAC Chapter 213.

Print Name of Geologist: Richard S. Record

Telephone: (972) 791-3222

Date: October 20, 2022

Fax: _____

Representing: _____ (Name of Company and TBPG or TBP registration number) EnSafe, Inc (Lic. No 3358)

Signature of Geologist:

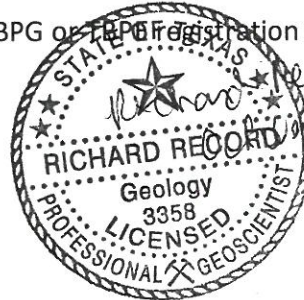

Regulated Entity Name: Comal Iron & Metals

Project Information

1. Date(s) Geologic Assessment was performed: October 18, 2022

2. Type of Project:

WPAP

AST

SCS

UST

3. Location of Project:

Recharge Zone

Transition Zone

Contributing Zone within the Transition Zone

4. **Attachment A - Geologic Assessment Table.** Completed Geologic Assessment Table (Form TCEQ-0585-Table) is attached.
5. Soil cover on the project site is summarized in the table below and uses the SCS Hydrologic Soil Groups* (Urban Hydrology for Small Watersheds, Technical Release No. 55, Appendix A, Soil Conservation Service, 1986). If there is more than one soil type on the project site, show each soil type on the site Geologic Map or a separate soils map.

Table 1 - Soil Units, Infiltration Characteristics and Thickness

Soil Name	Group*	Thickness(feet)
Comfort Rock	B	3.25
Purves Clay	B	3.25

* Soil Group Definitions (Abbreviated)

- A. Soils having a high infiltration rate when thoroughly wetted.
- B. Soils having a moderate infiltration rate when thoroughly wetted.
- C. Soils having a slow infiltration rate when thoroughly wetted.
- D. Soils having a very slow infiltration rate when thoroughly wetted.

6. **Attachment B – Stratigraphic Column.** A stratigraphic column showing formations, members, and thicknesses is attached. The outcropping unit, if present, should be at the top of the stratigraphic column. Otherwise, the uppermost unit should be at the top of the stratigraphic column.
7. **Attachment C – Site Geology.** A narrative description of the site specific geology including any features identified in the Geologic Assessment Table, a discussion of the potential for fluid movement to the Edwards Aquifer, stratigraphy, structure(s), and karst characteristics is attached.
8. **Attachment D – Site Geologic Map(s).** The Site Geologic Map must be the same scale as the applicant's Site Plan. The minimum scale is 1": 400'

Applicant's Site Plan Scale: 1" = 200 and 400'

Site Geologic Map Scale: 1" = 200 '

Site Soils Map Scale (if more than 1 soil type): 1" = _____ '

9. Method of collecting positional data:

Global Positioning System (GPS) technology.

Other method(s). Please describe method of data collection: GPS for Well: Edwards Aquifer Auth.

10. The project site and boundaries are clearly shown and labeled on the Site Geologic Map.
11. Surface geologic units are shown and labeled on the Site Geologic Map.

12. Geologic or manmade features were discovered on the project site during the field investigation. They are shown and labeled on the Site Geologic Map and are described in the attached Geologic Assessment Table.
- Geologic or manmade features were not discovered on the project site during the field investigation.
13. The Recharge Zone boundary is shown and labeled, if appropriate.
14. All known wells (test holes, water, oil, unplugged, capped and/or abandoned, etc.): If applicable, the information must agree with Item No. 20 of the WPAP Application Section.
- There are 1 (#) wells present on the project site and the locations are shown and labeled. (Check all of the following that apply.)
- The wells are not in use and have been properly abandoned.
- The wells are not in use and will be properly abandoned.
- The wells are in use and comply with 16 TAC Chapter 76.
- There are no wells or test holes of any kind known to exist on the project site.

Administrative Information

15. Submit one (1) original and one (1) copy of the application, plus additional copies as needed for each affected incorporated city, groundwater conservation district, and county in which the project will be located. The TCEQ will distribute the additional copies to these jurisdictions. The copies must be submitted to the appropriate regional office.



Section 3: Geologic Assessment Form (TCEQ-0585)

ATTACHMENT A

**Comal Iron and Metals – Geologic Assessment Table
(TCEQ-0585-Table)**

GEOLOGIC ASSESSMENT TABLE						PROJECT NAME: Comal Iron & Metals Facility															
LOCATION			FEATURE CHARACTERISTICS									EVALUATION		PHYSICAL SETTING							
1A	1B *	1C *	2A	2B	3	4			5	5A	6	7	8A	8B	9	10	11		12		
FEATURE ID	LATITUDE	LONGITUDE	FEATURE TYPE	POINTS	FORMATION	DIMENSIONS (FEET)			TREND (DEGREES)	DOM	DENSITY (NO/FT)	APERTURE (FEET)	INFILL	RELATIVE INFILTRATION RATE	TOTAL	SENSITIVITY		CATCHMENT AREA (ACRES)	TOPOGRAPHY		
						X	Y	Z		10						<40	>40	<1.6	>1.6		
Water Well	N 29° 44' 47.73"	W 98° 6' 3.92"	MB	30	Ked	0.5'	0.5'	114'					None							Flat	

* DATUM:

2A TYPE	TYPE	2B POINTS
C	Cave	30
SC	Solution cavity	20
SF	Solution-enlarged fracture(s)	20
F	Fault	20
O	Other natural bedrock features	5
MB	Manmade feature in bedrock	30
SW	Swallow hole	30
SH	Sinkhole	20
CD	Non-karst closed depression	5
Z	Zone, clustered or aligned features	30

8A INFILLING	
N	None, exposed bedrock
C	Coarse - cobbles, breakdown, sand, gravel
O	Loose or soft mud or soil, organics, leaves, sticks, dark colors
F	Fines, compacted clay-rich sediment, soil profile, gray or red colors
V	Vegetation. Give details in narrative description
FS	Flowstone, cements, cave deposits
X	Other materials

12 TOPOGRAPHY
Cliff, Hilltop, Hillside, Drainage, Floodplain, Streambed

I have read, I understood, and I have followed the Texas Commission on Environmental Quality's Instructions to Geologists. The information presented here complies with that document and is a true representation of the conditions observed in the field. My signature certifies that I am qualified as a geologist as defined by 30 TAC Chapter 213.

Richard Record

Date 10/20/2022
 Sheet 1 of 1

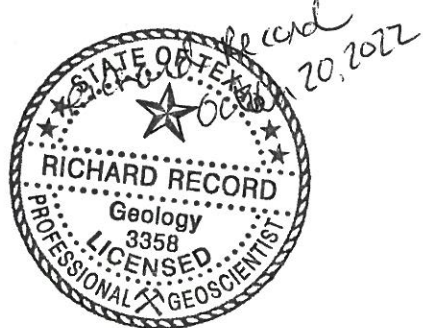

Original & Current owner: Johnnie (not Johnny) Rodriguez of Comal Iron Works, Inc.

1431 FM 306; W109-565; SWR in Records

Send original copy by certified return receipt requested

TNRCC, MC 177, P.O. Box 13087, Austin, TX 78711-30

Texas Water Well Drillers Advisory Council
MC 177
P.O. Box 13087
Austin, TX 78711-3087
512-239-0530

State of Texas
WELL REPORT

ATTENTION OWNER: Confidentiality
Privilege Notice on an reverse side
of Well Owner's copy (pink)

1) OWNER: JOHNNY RODRIGUEZ ADDRESS 1431 FM306 NEW BRAUNFELS, TEXASS 78132

2) ADDRESS OF WELL: County COMAL City COMAL IRON INC. State () Zip () GRID # 68-24-1

3) TYPE OF WORK (Check): [X] New Well [] Deepening [] Reconditioning [] Plugging
4) PROPOSED USE (Check): [] Monitor [] Environmental Soil Boring [X] Domestic [] Industrial [] Irrigation [] Injection [] Public Supply [] De-watering [] Testwell
If Public Supply well, were plans submitted to the TNRCC? [] Yes [] No

6) WELL LOG: Date Drilling: Started 6-24-19 97 Completed 19
DIAMETER OF HOLE: Dia. (in.) From (ft.) To (ft.)
6 1/2 Surface 110
7) DRILLING METHOD (Check): [] Driven [] Air Rotary [] Mud Rotary [] Bored [] Air Hammer [X] Cable Tool [] Jetted [] Other

8) Borehole Completion (Check): [X] Open Hole [] Straight Wall
[] Underreamed [] Gravel Packed [] Other
If Gravel Packed give interval ... from ft. to ft.

Table with 5 columns: From (ft.), To (ft.), Description and color of formation material, CASING, BLANK PIPE, AND WELL SCREEN DATA (Dia. (in.), New or Used, Steel, Plastic, etc. Perf., Slotted, etc. Screen Mfg., if commercial, Setting (ft.) From, To, Gage Casting Screen)
0 15 BROKEN LIMESTONE & SOFT LAYERS
5 30 YELLOW LIMESTONE & LOOSE HONEYCOMB
30 55 YELLOW LIMESTONE
35 110 LOOSE CAVY HONEYCOMB (WATER AT APPROXIMATE 65 FEET)
10 114 LIMESTONE LAYERS&HONEYCOMB(WATER)

Handwritten signature and date: AUG - 5 1997

TEXAS NATURAL RESOURCE COMMISSION
(Use for wells drilled on or after 10/1/84)

9) CEMENTING DATA [Rule 338.44(1)]
Cemented from 0 ft. to 55 ft. No. of sacks used 48
Method used MIXED BY HAND
Cemented by KUTSCHER DRILLING COMPANY
Distance to septic system field lines or other concentrated contamination ft.
Method of verification of above distance

10) SURFACE COMPLETION
[X] Specified Surface Slab Installed [Rule 338.44(2)(A)]
[] Specified Steel Sleeve Installed [Rule 338.44(3)(A)]
[] Pitless Adapter Used [Rule 338.44(3)(b)]
[] Approved Alternative Procedure Used [Rule 338.71]

11) WATER LEVEL:
Static level 55 ft. below land surface Date 6-24-97
Artesian flow gpm. Date

12) PACKERS: Type Depth
SCREEN WIRE 55 FEET

I hereby certify that this well was drilled by me (or under my supervision) and that each and all of the statements herein are true to the best of my knowledge and belief. I understand that failure to complete items 1 thru 15 will result in the log(s) being returned for completion and resubmittal.

COMPANY NAME KUTSCHER DRILLING COMPANY WELL DRILLER'S LICENSE NO. 1860 WPKL
ADDRESS 3810 HUNTER ROAD, SAN MARCOS, TEXAS 78666-9392 512-353-0075
(Signed) Robert E. Kutscher (Registered Well Driller) (Signed) (Registered Driller Trainee)

Please attach electric log, chemical analysis, and other pertinent information, if available.

1431 FM 306



Search

Basic Search
 Enter keywords

Advanced Search

Map Unit Legend

Comal and Hays Counties, Texas (TX604)
 Comal and Hays Counties, Texas (TX604)

Map Unit Symbol	Map Unit Name	Acres in AOI	Percent of AOI
CrD	Comfort-Rock outcrop complex, 1 to 8 percent slopes	3.8	85.5%
PuC	Purves clay, 1 to 5 percent slopes	0.7	14.5%
Totals for Area of Interest		4.5	100.0%

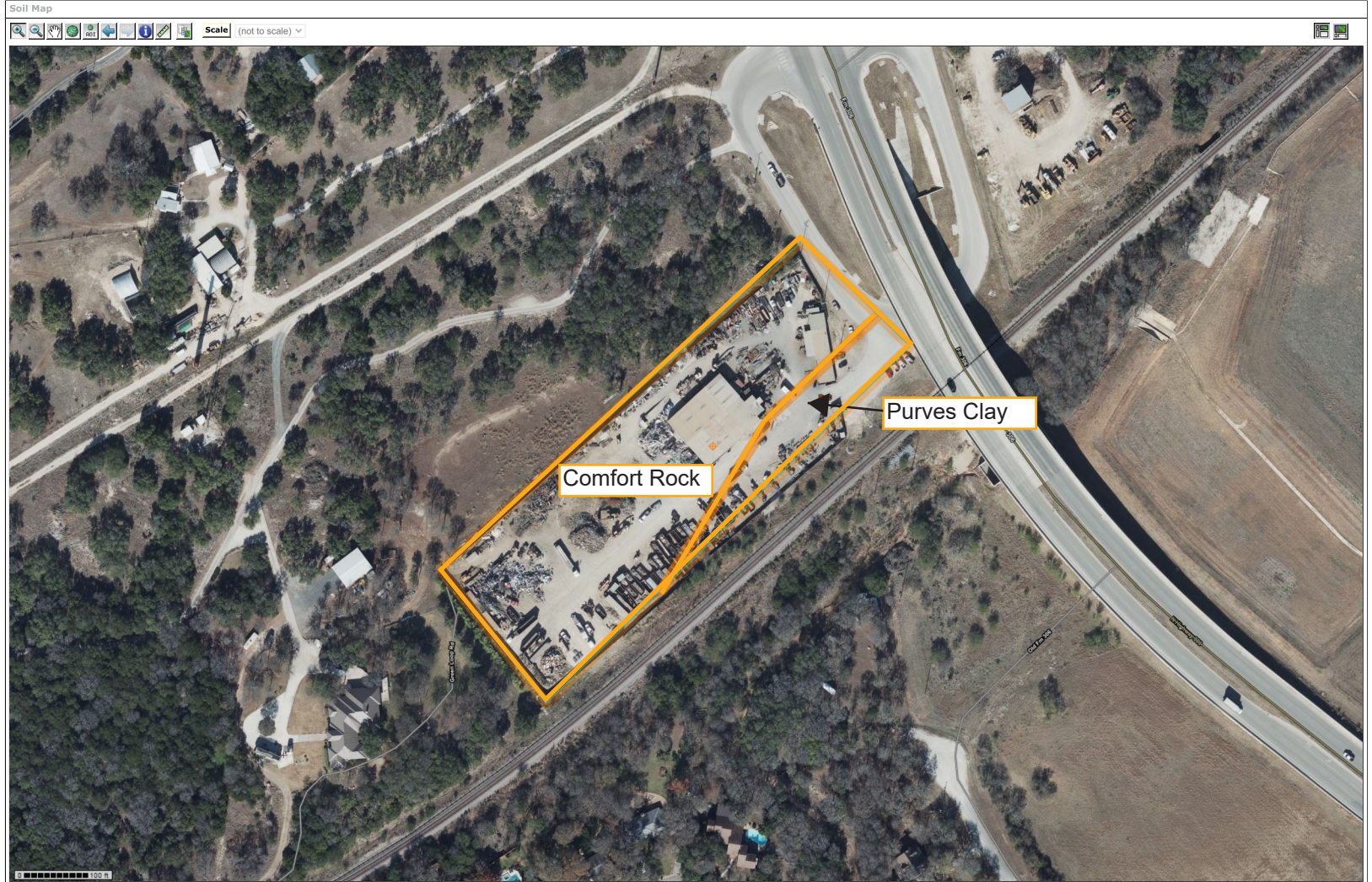

Warning: Soil Map may not be valid at this scale.

You have zoomed in beyond the scale at which the soil map for this area is intended to be used. Mapping of soils is done at a particular scale. The soil surveys that comprise your AOI were mapped at 1:20,000. The design of map units and the level of detail shown in the resulting soil map are dependent on that map scale. Enlargement of maps beyond the scale of mapping can cause misunderstanding of the detail of mapping and accuracy of soil line placement. The maps do not show the small areas of contrasting soils that could have been shown at a more detailed scale.

Comal and Hays Counties, Texas

CrD—Comfort-Rock outcrop complex, 1 to 8 percent slopes

Map Unit Setting

National map unit symbol: 2yly4

Elevation: 1,000 to 2,300 feet

Mean annual precipitation: 33 to 37 inches

Mean annual air temperature: 66 to 68 degrees F

Frost-free period: 220 to 260 days

Farmland classification: Not prime farmland

Map Unit Composition

Comfort and similar soils: 70 percent

Rock outcrop: 15 percent

Minor components: 15 percent

Estimates are based on observations, descriptions, and transects of the mapunit.

Description of Comfort

Setting

Landform: Ridges

Landform position (two-dimensional): Summit, shoulder

Landform position (three-dimensional): Interfluve

Down-slope shape: Convex

Across-slope shape: Linear

Parent material: Residuum weathered from limestone

Typical profile

A - 0 to 6 inches: very stony clay

Bt - 6 to 13 inches: extremely stony clay

R - 13 to 40 inches: bedrock

Properties and qualities

Slope: 1 to 8 percent

Surface area covered with cobbles, stones or boulders: 0.5 percent

Depth to restrictive feature: 10 to 20 inches to lithic bedrock

Drainage class: Well drained

Runoff class: Very high

Capacity of the most limiting layer to transmit water

(Ksat): Moderately low to moderately high (0.06 to 0.20 in/hr)

Depth to water table: More than 80 inches

Frequency of flooding: None

Frequency of ponding: None

Calcium carbonate, maximum content: 5 percent

Maximum salinity: Nonsaline to very slightly saline (0.0 to 2.0 mmhos/cm)

Sodium adsorption ratio, maximum: 1.0

Available water supply, 0 to 60 inches: Very low (about 0.8 inches)

Interpretive groups

Land capability classification (irrigated): None specified
Land capability classification (nonirrigated): 6s
Hydrologic Soil Group: D
Ecological site: R081CY360TX - Low Stony Hill 29-35 PZ
Hydric soil rating: No

Description of Rock Outcrop

Setting

Landform: Ridges
Landform position (two-dimensional): Summit, shoulder
Landform position (three-dimensional): Interfluve
Down-slope shape: Convex
Across-slope shape: Linear
Parent material: Limestone

Typical profile

R - 0 to 80 inches: bedrock

Properties and qualities

Slope: 1 to 8 percent
Depth to restrictive feature: 0 to 2 inches to lithic bedrock
Runoff class: High
Capacity of the most limiting layer to transmit water (Ksat): Moderately low to high (0.06 to 1.98 in/hr)

Interpretive groups

Land capability classification (irrigated): None specified
Land capability classification (nonirrigated): 8
Hydrologic Soil Group: D
Hydric soil rating: No

Minor Components

Eckrant

Percent of map unit: 6 percent
Landform: Ridges
Landform position (two-dimensional): Summit, shoulder
Landform position (three-dimensional): Interfluve
Down-slope shape: Convex
Across-slope shape: Linear
Ecological site: R081CY360TX - Low Stony Hill 29-35 PZ
Hydric soil rating: No

Real

Percent of map unit: 3 percent
Landform: Ridges
Landform position (two-dimensional): Summit, shoulder
Landform position (three-dimensional): Interfluve
Down-slope shape: Convex
Across-slope shape: Linear
Ecological site: R081CY355TX - Adobe 29-35 PZ
Hydric soil rating: No

Purves

Percent of map unit: 3 percent

Landform: Ridges

Landform position (two-dimensional): Summit, shoulder, backslope

Landform position (three-dimensional): Interfluve, side slope

Down-slope shape: Convex

Across-slope shape: Linear

Ecological site: R081CY574TX - Shallow 29-35 PZ

Hydric soil rating: No

Rumple

Percent of map unit: 3 percent

Landform: Ridges

Landform position (two-dimensional): Summit, shoulder

Landform position (three-dimensional): Interfluve

Down-slope shape: Convex

Across-slope shape: Linear

Ecological site: R081CY359TX - Gravelly Redland 29-35 PZ

Hydric soil rating: No

Data Source Information

Soil Survey Area: Comal and Hays Counties, Texas

Survey Area Data: Version 19, Aug 24, 2022

Comal and Hays Counties, Texas

PuC—Purves clay, 1 to 5 percent slopes

Map Unit Setting

National map unit symbol: 2ylvf
Elevation: 400 to 1,800 feet
Mean annual precipitation: 33 to 37 inches
Mean annual air temperature: 65 to 69 degrees F
Frost-free period: 220 to 260 days
Farmland classification: Not prime farmland

Map Unit Composition

Purves and similar soils: 90 percent
Minor components: 10 percent
Estimates are based on observations, descriptions, and transects of the mapunit.

Description of Purves

Setting

Landform: Ridges
Landform position (two-dimensional): Shoulder, backslope
Landform position (three-dimensional): Side slope
Down-slope shape: Convex
Across-slope shape: Linear
Parent material: Residuum weathered from limestone

Typical profile

Ak1 - 0 to 10 inches: clay
Ak2 - 10 to 16 inches: clay
Bk - 16 to 19 inches: clay
R - 19 to 40 inches: bedrock

Properties and qualities

Slope: 1 to 5 percent
Depth to restrictive feature: 8 to 20 inches to lithic bedrock
Drainage class: Well drained
Runoff class: Medium
Capacity of the most limiting layer to transmit water (Ksat): Moderately low to moderately high (0.06 to 0.57 in/hr)
Depth to water table: More than 80 inches
Frequency of flooding: None
Frequency of ponding: None
Calcium carbonate, maximum content: 50 percent
Maximum salinity: Nonsaline to very slightly saline (0.0 to 2.0 mmhos/cm)
Sodium adsorption ratio, maximum: 1.0
Available water supply, 0 to 60 inches: Very low (about 2.4 inches)

Interpretive groups

Land capability classification (irrigated): None specified

Land capability classification (nonirrigated): 4s
Hydrologic Soil Group: D
Ecological site: R081CY574TX - Shallow 29-35 PZ
Hydric soil rating: No

Minor Components

Eckrant

Percent of map unit: 4 percent
Landform: Ridges
Landform position (two-dimensional): Backslope
Landform position (three-dimensional): Side slope
Down-slope shape: Convex
Across-slope shape: Linear
Ecological site: R081CY360TX - Low Stony Hill 29-35 PZ
Hydric soil rating: No

Brackett

Percent of map unit: 3 percent
Landform: Ridges
Landform position (two-dimensional): Shoulder, backslope
Landform position (three-dimensional): Side slope
Down-slope shape: Convex
Across-slope shape: Convex
Ecological site: R081CY355TX - Adobe 29-35 PZ
Hydric soil rating: No

Doss

Percent of map unit: 2 percent
Landform: Ridges
Landform position (two-dimensional): Backslope
Landform position (three-dimensional): Side slope
Down-slope shape: Convex
Across-slope shape: Linear
Ecological site: R081CY574TX - Shallow 29-35 PZ
Hydric soil rating: No

Rock outcrop

Percent of map unit: 1 percent
Landform: Ridges
Landform position (two-dimensional): Backslope
Landform position (three-dimensional): Side slope
Down-slope shape: Convex
Across-slope shape: Convex
Hydric soil rating: No

Data Source Information

Soil Survey Area: Comal and Hays Counties, Texas
Survey Area Data: Version 19, Aug 24, 2022



Section 3: Geologic Assessment Form (TCEQ-0585)

ATTACHMENT B

Comal Iron and Metals – Stratigraphic Column

Attachment B - Stratigraphic Column

Geologic Formation	Description	Age	Thickness
Leona Formation (Qle)	Fluviatile terrace deposits of gravel, sand, silt, and clay.	Pleistocene	>50 feet
Edwards Limestone (Ked)*	Massive to thin bedded limestone and dolostones. Solution features and collapse zones are present throughout the formation.	Cretaceous	300-500 feet

*The Edwards Limestone is both overlain by the Leona Formation and outcrops at the Site.

Figure 6

Edwards Aquifer Hydrogeologic Dip Section

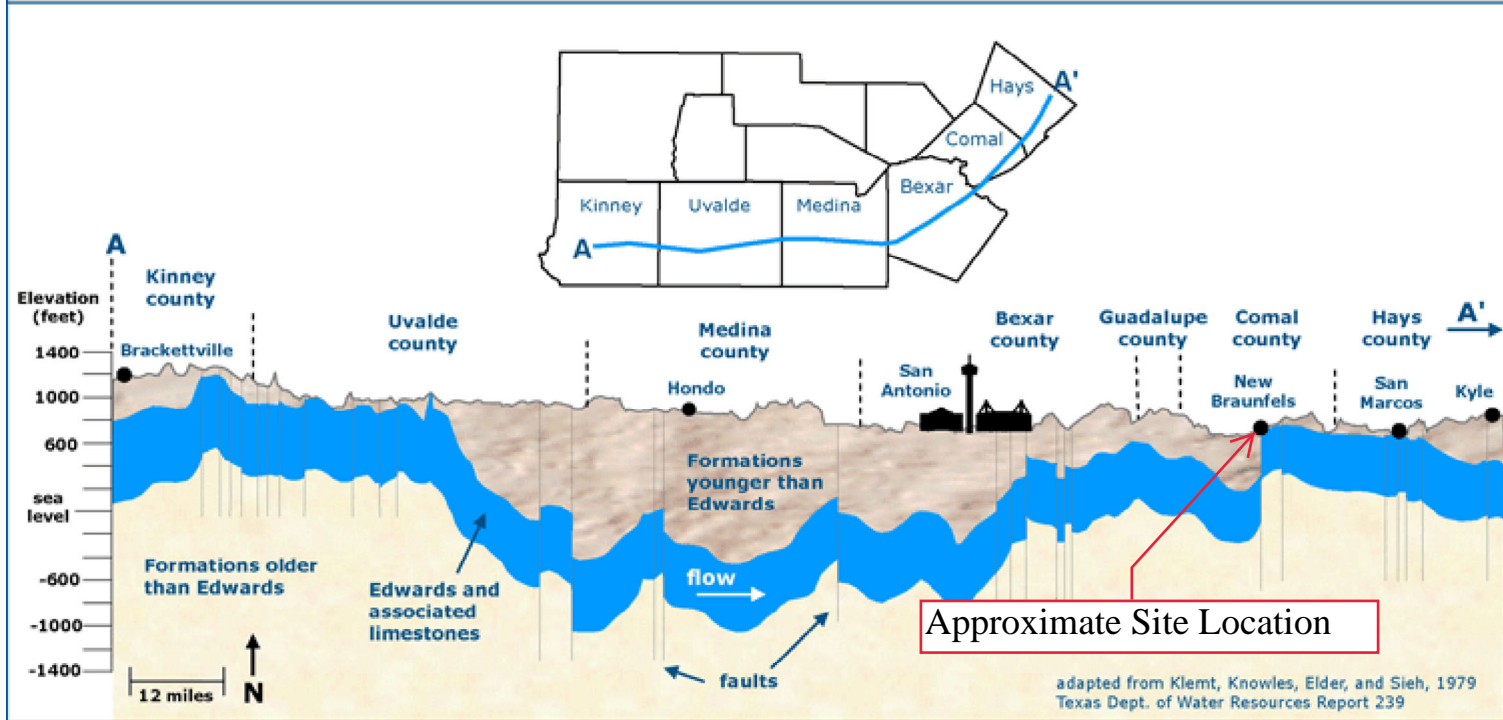



Section 3: Geologic Assessment Form (TCEQ-0585)

ATTACHMENT C

Comal Iron and Metals – Site Geology

The Site is an approximate 4.6-acre property located at 1431 FM 306 in New Braunfels, Comal County, Texas. The Site is currently a metal scrap yard and is developed with an approximate 8,700 square foot commercial building. One man-made subsurface feature, in the form of a water well, was currently identified at the Site. The water well is domestic in use, was drilled to a depth of 114 feet below surface, installed in 1997, and registered with the Edwards Aquifer Authority. According to the well report included in Attachment A, the well annulus was cemented from the surface down to 55 feet below surface. The location of the water well is depicted on the Site Geologic Map included in Attachment A. The Site historically maintained a septic system but has not been in use for several years and the location of the former septic tank at the Site is unknown.

According to the Geologic Atlas of Texas San Antonio Sheet, the southern portion of the Site overlies the Leona Formation and the northern portion of the Site overlies the Edwards Limestone formation. Only a small strip along the northern boundary of the Site consists of the Edwards Limestone formation. A description of each formation is discussed below.

Leona Formation

The Leona Formation is a Pleistocene aged formation consisting of fluvial terrace deposits of gravel, sand, silt, and clay. The maximum thickness of the Leona Formation is approximately 50 feet.

Edwards Limestone Formation

The Edwards Limestone Formation is an early Cretaceous aged formation consisting of massive to thin bedded limestone and dolostones. The thickness of the Edwards Limestone Formation ranges from approximately 300 feet to 500 feet. The exposed surface outcrop of the Edwards Limestone in Comal County is considered a recharge zone for the groundwater in the Edwards Aquifer.

No evidence of additional water wells, other than the domestic water well discussed above, were identified at the Site through visual inspection and review of the Texas Water Development Board (TWDB) on-line records. A map depicting the Site and surrounding area from the TWDB is included in Attachment A. The Site was also not identified within the 100-year flood plain. A FEMA national flood hazard map depicting the Site is included in Attachment D.

Edwards Aquifer Viewer Custom Print

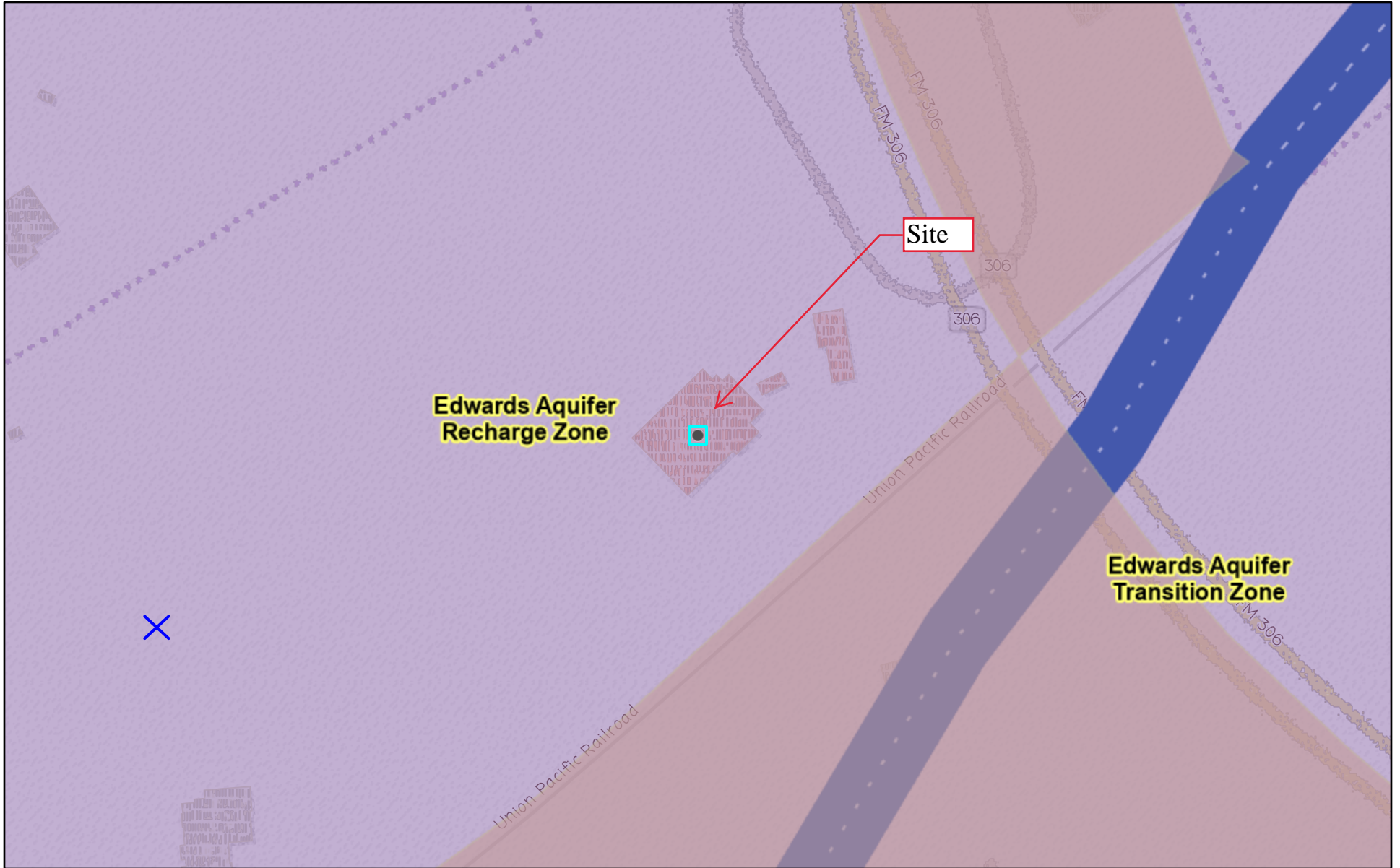

10/18/2022, 6:00:34 PM

- | | | |
|--|--|---|
|  Edwards Aquifer Label |  City/Place |  Edwards Aquifer Authority |
|  Edwards Aquifer Boundary |  Groundwater Conservation Districts |  TX Counties |
|  Edwards Aquifer Boundary central line |  Comal Trinity GCD |  7.5 Minute Quad Grid |

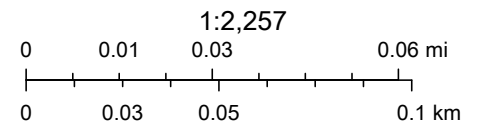

Esri Community Maps Contributors, City of New Braunfels, Comal County, Texas Parks & Wildlife, © OpenStreetMap, Microsoft, CONANP, Esri, HERE,

Web AppBuilder for ArcGIS



Section 3: Geologic Assessment Form (TCEQ-0585)







ATTACHMENT D

Comal Iron and Metals — Site Geology Map(s)

The site plan can be found in Section 4 - Attachment E.



LEGEND

-  WATER WELL
-  Kdr BUDA LIMESTONE & DEL RIO CLAY
-  Ked EDWARDS LIMESTONE
-  Qle LEONA FORMATION
-  Qt FLUVIATILE TERRACE DEPOSITS
-  APPROXIMATE SUBJECT PROPERTY BOUNDARY

X:\James\Environmental\GeoMap\2.mxd

NAD 1983 STATE PLANE
TEXAS SOUTH CENTRAL FEET

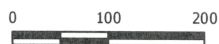

SCALE IN FEET

ATTACHMENT D
SITE GEOLOGIC MAP
1431 FM 306
NEW BRAUNFELS, TEXAS

REQUESTED BY:	CW
DRAWN BY:	MS
DATE:	11/9/2022
PROJECT:	0888833643

ENSAFE
Creative thinking. Custom solutions.
800.588.7962 | www.ensafe.com

National Flood Hazard Layer FIRMMette



98°6'24"W 29°45'2"N

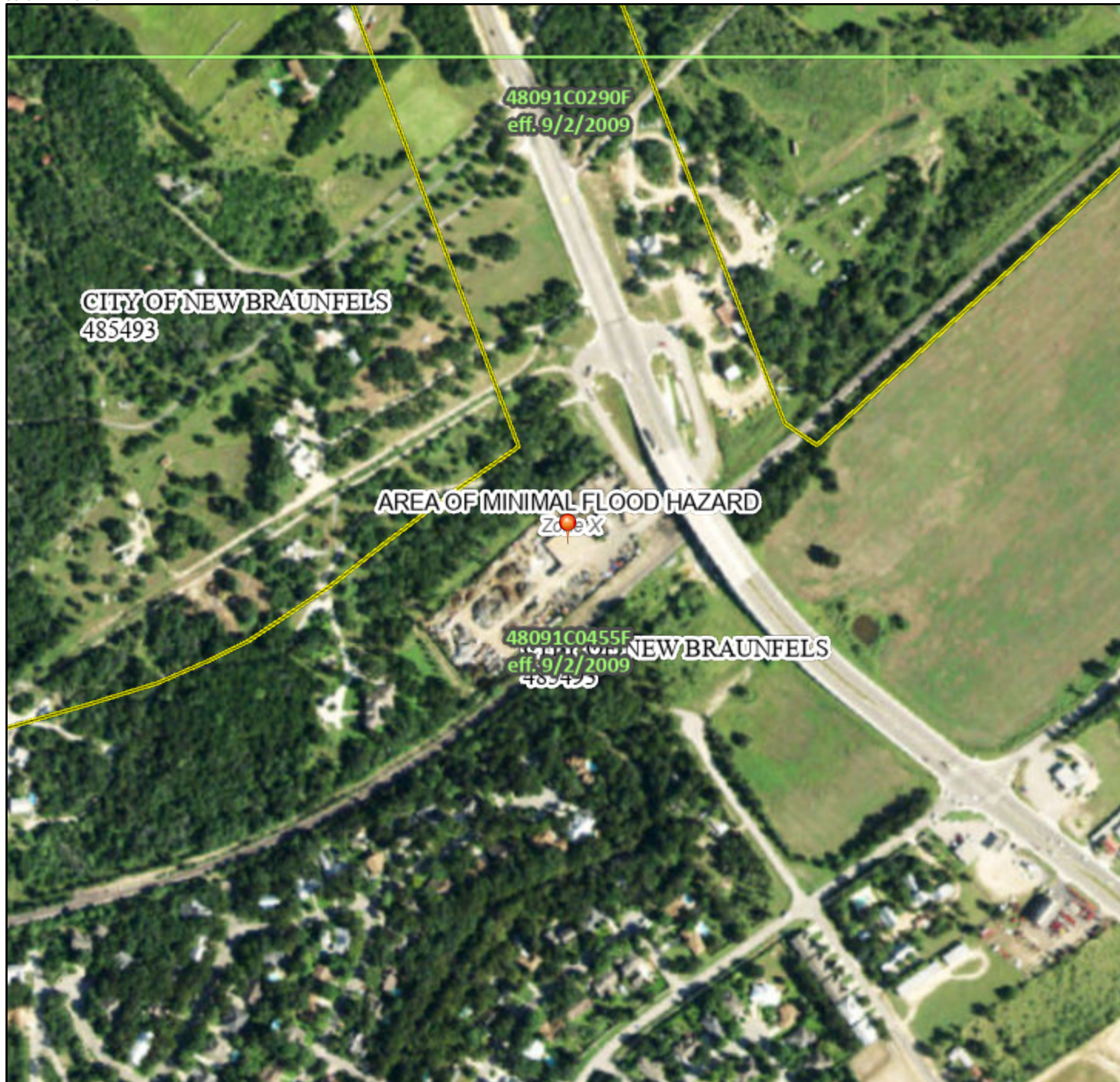

98°5'47"W 29°44'30"N

Basemap: USGS National Map: Orthoimagery: Data refreshed October, 2020

Legend

SEE FIS REPORT FOR DETAILED LEGEND AND INDEX MAP FOR FIRM PANEL LAYOUT

SPECIAL FLOOD HAZARD AREAS		Without Base Flood Elevation (BFE) Zone A, V, A99
		With BFE or Depth Zone AE, AO, AH, VE, AR
		Regulatory Floodway
OTHER AREAS OF FLOOD HAZARD		0.2% Annual Chance Flood Hazard, Areas of 1% annual chance flood with average depth less than one foot or with drainage areas of less than one square mile Zone X
		Future Conditions 1% Annual Chance Flood Hazard Zone X
		Area with Reduced Flood Risk due to Levee. See Notes. Zone X
		Area with Flood Risk due to Levee Zone D
OTHER AREAS		NO SCREEN Area of Minimal Flood Hazard Zone X
		Effective LOMRs
GENERAL STRUCTURES		Area of Undetermined Flood Hazard Zone D
		Channel, Culvert, or Storm Sewer
		Levee, Dike, or Floodwall
OTHER FEATURES		20.2 Cross Sections with 1% Annual Chance
		17.5 Water Surface Elevation
		Coastal Transect
		Base Flood Elevation Line (BFE)
		Limit of Study
		Jurisdiction Boundary
MAP PANELS		Digital Data Available
		No Digital Data Available
		Unmapped



The pin displayed on the map is an approximate point selected by the user and does not represent an authoritative property location.

This map complies with FEMA's standards for the use of digital flood maps if it is not void as described below. The basemap shown complies with FEMA's basemap accuracy standards

The flood hazard information is derived directly from the authoritative NFHL web services provided by FEMA. This map was exported on **10/18/2022 at 9:33 AM** and does not reflect changes or amendments subsequent to this date and time. The NFHL and effective information may change or become superseded by new data over time.

This map image is void if the one or more of the following map elements do not appear: basemap imagery, flood zone labels, legend, scale bar, map creation date, community identifiers, FIRM panel number, and FIRM effective date. Map images for unmapped and unmodernized areas cannot be used for regulatory purposes.



Section 4

Comal Iron and Metals – Water Pollution Abatement Application
Form (TCEQ-0584)

Water Pollution Abatement Plan Application

Texas Commission on Environmental Quality

for Regulated Activities on the Edwards Aquifer Recharge Zone and Relating to 30 TAC §213.5(b), Effective June 1, 1999

To ensure that the application is administratively complete, confirm that all fields in the form are complete, verify that all requested information is provided, consistently reference the same site and contact person in all forms in the application, and ensure forms are signed by the appropriate party.

Note: Including all the information requested in the form and attachments contributes to more streamlined technical reviews.

Signature

To the best of my knowledge, the responses to this form accurately reflect all information requested concerning the proposed regulated activities and methods to protect the Edwards Aquifer. This **Water Pollution Abatement Plan Application Form** is hereby submitted for TCEQ review and Executive Director approval. The form was prepared by:

Print Name of Customer/Agent: Comal Iron and Metals/Adriana Lee

Date: 10/11/2022

Signature of Customer/Agent:



Regulated Entity Name: Comal Iron and Metals

Regulated Entity Information

1. The type of project is:

- Residential: Number of Lots: _____
- Residential: Number of Living Unit Equivalents: _____
- Commercial
- Industrial
- Other: _____

2. Total site acreage (size of property): 4.3

3. Estimated projected population: _____

4. The amount and type of impervious cover expected after construction are shown below:

Table 1 - Impervious Cover Table

Impervious Cover of Proposed Project	Sq. Ft.	Sq. Ft./Acre	Acres
Structures/Rooftops	16,200	÷ 43,560 =	0.37
Parking	58,000	÷ 43,560 =	1.33
Other paved surfaces	56,747	÷ 43,560 =	1.30
Total Impervious Cover	130,947	÷ 43,560 =	1.35

Total Impervious Cover 3.01 ÷ **Total Acreage** 4.3 X 100 = 70 % Impervious Cover

5. **Attachment A - Factors Affecting Surface Water Quality.** A detailed description of all factors that could affect surface water and groundwater quality that addresses ultimate land use is attached.
6. Only inert materials as defined by 30 TAC §330.2 will be used as fill material.

For Road Projects Only

Complete questions 7 - 12 if this application is exclusively for a road project.

7. Type of project:

- TXDOT road project.
- County road or roads built to county specifications.
- City thoroughfare or roads to be dedicated to a municipality.
- Street or road providing access to private driveways.

8. Type of pavement or road surface to be used:

- Concrete
- Asphaltic concrete pavement
- Other: _____

9. Length of Right of Way (R.O.W.): _____ feet.

Width of R.O.W.: _____ feet.

L x W = _____ Ft² ÷ 43,560 Ft²/Acre = _____ acres.

10. Length of pavement area: _____ feet.

Width of pavement area: _____ feet.

L x W = _____ Ft² ÷ 43,560 Ft²/Acre = _____ acres.

Pavement area _____ acres ÷ R.O.W. area _____ acres x 100 = _____% impervious cover.

11. A rest stop will be included in this project.
- A rest stop will not be included in this project.

12. Maintenance and repair of existing roadways that do not require approval from the TCEQ Executive Director. Modifications to existing roadways such as widening roads/adding shoulders totaling more than one-half (1/2) the width of one (1) existing lane require prior approval from the TCEQ.

Stormwater to be generated by the Proposed Project

13. **Attachment B - Volume and Character of Stormwater.** A detailed description of the volume (quantity) and character (quality) of the stormwater runoff which is expected to occur from the proposed project is attached. The estimates of stormwater runoff quality and quantity are based on the area and type of impervious cover. Include the runoff coefficient of the site for both pre-construction and post-construction conditions.

Wastewater to be generated by the Proposed Project

14. The character and volume of wastewater is shown below:

<u>100</u> % Domestic	<u>30</u> Gallons/day
<u> </u> % Industrial	<u> </u> Gallons/day
<u> </u> % Commingled	<u> </u> Gallons/day
TOTAL gallons/day <u>30</u>	

15. Wastewater will be disposed of by:

On-Site Sewage Facility (OSSF/Septic Tank):

Attachment C - Suitability Letter from Authorized Agent. An on-site sewage facility will be used to treat and dispose of the wastewater from this site. The appropriate licensing authority's (authorized agent) written approval is attached. It states that the land is suitable for the use of private sewage facilities and will meet or exceed the requirements for on-site sewage facilities as specified under 30 TAC Chapter 285 relating to On-site Sewage Facilities.

Each lot in this project/development is at least one (1) acre (43,560 square feet) in size. The system will be designed by a licensed professional engineer or registered sanitarian and installed by a licensed installer in compliance with 30 TAC Chapter 285.

Sewage Collection System (Sewer Lines):

Private service laterals from the wastewater generating facilities will be connected to an existing SCS.

Private service laterals from the wastewater generating facilities will be connected to a proposed SCS.

The SCS was previously submitted on _____.

The SCS was submitted with this application.

The SCS will be submitted at a later date. The owner is aware that the SCS may not be installed prior to Executive Director approval.

- The sewage collection system will convey the wastewater to the _____ (name) Treatment Plant. The treatment facility is: Toilet rentals and service through:
Big John Site Services
243 Trade Center Drive
New Braunfels, TX 78130
- Existing.
 Proposed.

16. All private service laterals will be inspected as required in 30 TAC §213.5.

Site Plan Requirements

Items 17 – 28 must be included on the Site Plan.

17. The Site Plan must have a minimum scale of 1" = 400'.

Site Plan Scale: 1" = 200 and 400

18. 100-year floodplain boundaries:

Some part(s) of the project site is located within the 100-year floodplain. The floodplain is shown and labeled.

No part of the project site is located within the 100-year floodplain.

The 100-year floodplain boundaries are based on the following specific (including date of material) sources(s): 10/18/2022 FEMA Flood Map Service Center

19. The layout of the development is shown with existing and finished contours at appropriate, but not greater than ten-foot contour intervals. Lots, recreation centers, buildings, roads, open space, etc. are shown on the plan.

The layout of the development is shown with existing contours at appropriate, but not greater than ten-foot intervals. Finished topographic contours will not differ from the existing topographic configuration and are not shown. Lots, recreation centers, buildings, roads, open space, etc. are shown on the site plan.

20. All known wells (oil, water, unplugged, capped and/or abandoned, test holes, etc.):

There are 1 (#) wells present on the project site and the locations are shown and labeled. (Check all of the following that apply)

The wells are not in use and have been properly abandoned.

The wells are not in use and will be properly abandoned.

The wells are in use and comply with 16 TAC §76.

There are no wells or test holes of any kind known to exist on the project site.

21. Geologic or manmade features which are on the site:

All sensitive geologic or manmade features identified in the Geologic Assessment are shown and labeled.

No sensitive geologic or manmade features were identified in the Geologic Assessment.

Attachment D - Exception to the Required Geologic Assessment. A request and justification for an exception to a portion of the Geologic Assessment is attached.

- 22. The drainage patterns and approximate slopes anticipated after major grading activities.
- 23. Areas of soil disturbance and areas which will not be disturbed.
- 24. Locations of major structural and nonstructural controls. These are the temporary and permanent best management practices.
- 25. Locations where soil stabilization practices are expected to occur.
- 26. Surface waters (including wetlands).
 - N/A
- 27. Locations where stormwater discharges to surface water or sensitive features are to occur.
 - There will be no discharges to surface water or sensitive features.
- 28. Legal boundaries of the site are shown.

Administrative Information

- 29. Submit one (1) original and one (1) copy of the application, plus additional copies as needed for each affected incorporated city, groundwater conservation district, and county in which the project will be located. The TCEQ will distribute the additional copies to these jurisdictions. The copies must be submitted to the appropriate regional office.
- 30. Any modification of this WPAP will require Executive Director approval, prior to construction, and may require submission of a revised application, with appropriate fees.



Section 4: Water Pollution Abatement Application Form (TCEQ-0584)

ATTACHMENT A

Comal Iron and Metals – Factors Affecting Surface Water Quality

Potential Sources of Pollutants

- Equipment used to operate the metal recycling facility include shop vehicles, delivery trucks, forklifts, loaders, tractors, or other heavy equipment;
- Metals from turnings;
- Suspended solids from whitegoods;
- Assorted fluids from incoming material or company equipment;
- Portable toilet spills.



Section 4: Water Pollution Abatement Application Form (TCEQ-0584)

ATTACHMENT B

Comal Iron and Metals – Volume and Character of Stormwater

The 4.3-acre project site is located inside the Guadalupe River Basin. Stormwater runs through the property, into the swale along the southern fence line and flows out at the southwest corner of the property. The volume and character of the stormwater runoff is not expected to change existing conditions. The Contech Jellyfish Filter, along with impervious cover, containment bins, silt fencing, vegetated swale, and check dams will reduce the likelihood of pollutants from exiting the facility or reaching waterways.

Drainage Area 001
Existing Conditions
Area = 4.3-acres
Impervious Cover = 3.01-acres
Runoff Coefficient = 0.50566
Percent Impervious = 70%
 $Q_{25} = 5.330$ cfs

Drainage Area 001
Post Construction
Area = 4.3-acres
Impervious Cover = 3.01-acres
Runoff Coefficient = 0.50566
Percent Impervious = 70%
 $Q_{25} = 5.330$ cfs



Section 4: Water Pollution Abatement Application Form (TCEQ-0584)

ATTACHMENT C

Comal Iron and Metals – Suitability Letter from Authorized Agent (if OSSF is proposed)

This attachment does not apply to this submittal. There will not be an OSSF at the project site. Comal Iron and Metals uses a toilet rental service by Big John Site Services located at 243 Trade Center Drive, New Braunfels, Texas 78130. Six toilets are rented and serviced two times per week. Along with the rented portable toilets, portable sinks are used for washing hands. The portable sinks are also maintained by Big John.



Section 4: Water Pollution Abatement Application Form (TCEQ-0584)

ATTACHMENT D

Comal Iron and Metals – Exception to the Required Geologic Assessment (if requesting an exception)

This attachment does not apply to this submittal. An exception to the required Geologic Assessment is not required. A Geological Assessment of the project site was completed and is included in this submittal; see Section 3 of this report.



Section 4: Water Pollution Abatement Application Form (TCEQ-0584)

ATTACHMENT E

Comal Iron and Metals — Site Plan

The drainage patterns and approximate slopes anticipated after major grading activities. Including areas of soil disturbance, areas which will not be disturbed, and locations of major structural and nonstructural controls can be found in Attachment F in section 6.

LEGEND

- DIRECTION OF SURFACE RUNOFF
- BUILDING
- COVERED AREA
- SECONDARY CONTAINMENT
- CONCRETE
- FENCE LINE
- PROCESS MACHINES
- WATER WELL

TOTAL - OUTFALL 001
ACRES 4.3
IMPERVIOUS 70%

SCALE
1:200

FACILITY HAS NON-STORMWATER DISCHARGE ASSOCIATED WITH A/C AND AIR COMPRESSOR CONDENSATE IN THE DRAINAGE AREA OF OUTFALL 001.

RECEIVING WATER IS GUADALUPE RIVER.

GAUDALUPE RIVER IS NOT IMPAIRED.

CHECK DAMS 25 FT. APART

1	240-GALLON DWT	USED OIL
2	165-GALLON TOTE	HYDRAULIC FLUID
3	165-GALLON TOTE	MOTOR OIL
4	55-GALLON DRUM	ANTIFREEZE
5	55-GALLON DRUM	DEF

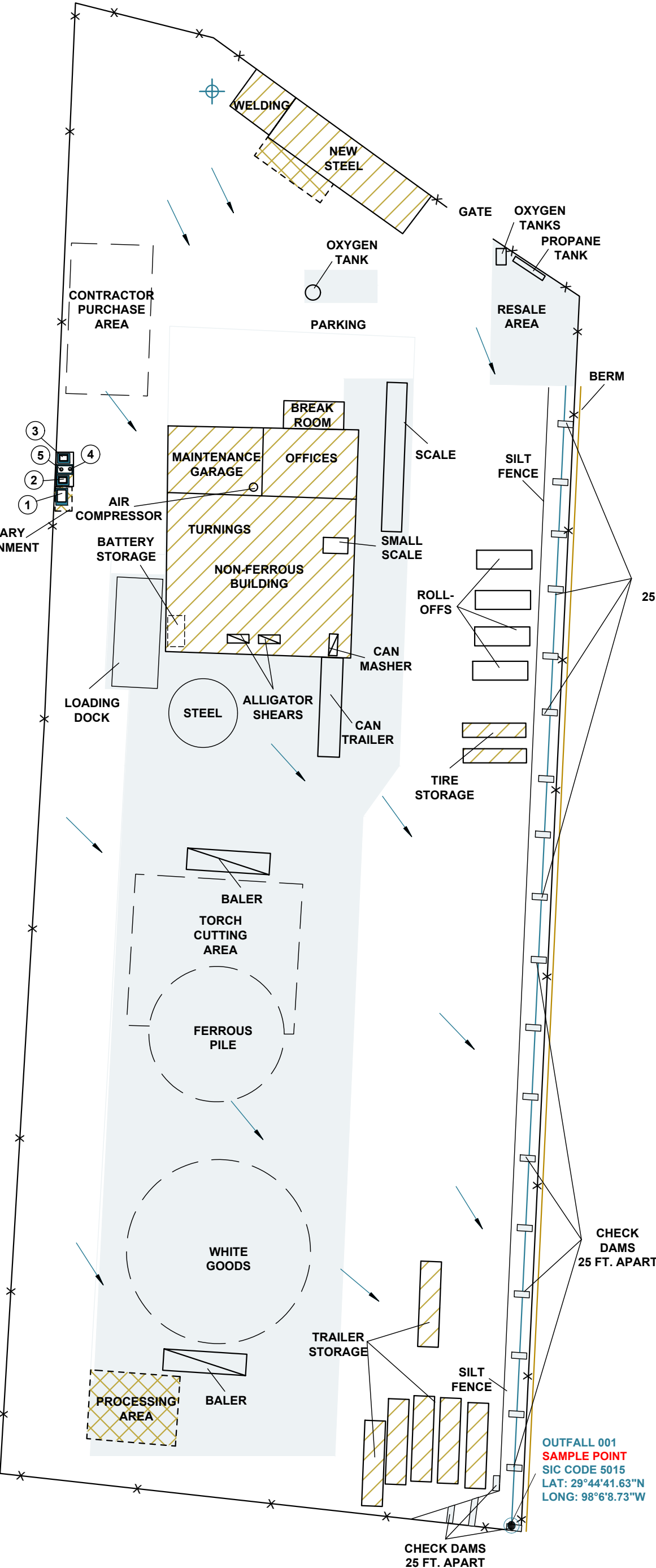

OUTFALL 001
SAMPLE POINT
SIC CODE 5015
LAT: 29°44'41.63"N
LONG: 98°6'8.73"W

JAMES ENVIRONMENTAL MANAGEMENT, INC. PO BOX 1323 GEORGETOWN, TEXAS 78627		SITE PLAN	SCALE 1:200	511-777
		COMAL IRON & METALS, INC. NEW BRAUNFELS, TEXAS	MH 09/22	FIG 2

LEGEND

- DIRECTION OF SURFACE RUNOFF
- BUILDING
- COVERED AREA
- SECONDARY CONTAINMENT
- CONCRETE
- FENCE LINE
- PROCESS MACHINES
- WATER WELL

TOTAL - OUTFALL 001
ACRES 4.3
IMPERVIOUS 70%

SCALE
1:400

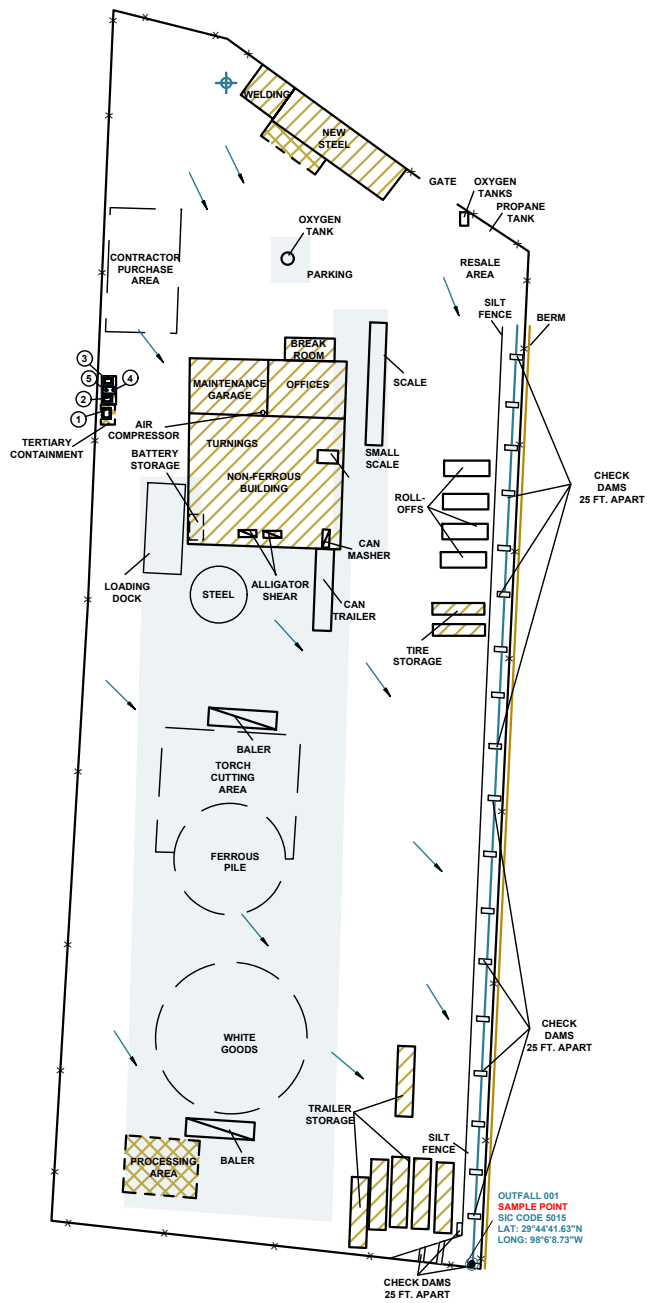

FACILITY HAS NON-STORMWATER DISCHARGE ASSOCIATED WITH A/C AND AIR COMPRESSOR CONDENSATE IN THE DRAINAGE AREA OF OUTFALL 001.

RECEIVING WATER IS GUADALUPE RIVER.

GAUDALUPE RIVER IS NOT IMPAIRED.

1	240-GALLON DWT	USED OIL
2	165-GALLON TOTE	HYDRAULIC FLUID
3	165-GALLON TOTE	MOTOR OIL
4	55-GALLON DRUM	ANTIFREEZE
5	55-GALLON DRUM	DEF

JAMES ENVIRONMENTAL
MANAGEMENT, INC.

PO BOX 1323
GEORGETOWN, TEXAS 78627



SITE PLAN

COMAL IRON & METALS, INC.

NEW BRAUNFELS, TEXAS

SCALE
1:400

MH

09/22

511-777

FIG 2



Section 5

Comal Iron and Metals – Temporary Stormwater Application Form (TCEQ-0602)

Temporary Stormwater Section

Texas Commission on Environmental Quality

for Regulated Activities on the Edwards Aquifer Recharge Zone and Relating to 30 TAC §213.5(b)(4)(A), (B), (D)(I) and (G); Effective June 1, 1999

To ensure that the application is administratively complete, confirm that all fields in the form are complete, verify that all requested information is provided, consistently reference the same site and contact person in all forms in the application, and ensure forms are signed by the appropriate party.

Note: Including all the information requested in the form and attachments contributes to more streamlined technical reviews.

Signature

To the best of my knowledge, the responses to this form accurately reflect all information requested concerning the proposed regulated activities and methods to protect the Edwards Aquifer. This **Temporary Stormwater Section** is hereby submitted for TCEQ review and executive director approval. The application was prepared by:

Print Name of Customer/Agent: Comal Iron and Metals/Adriana Lee

Date: 10/11/2022

Signature of Customer/Agent:



Regulated Entity Name: Comal Iron and Metals

Project Information

Potential Sources of Contamination

Examples: Fuel storage and use, chemical storage and use, use of asphaltic products, construction vehicles tracking onto public roads, and existing solid waste.

1. Fuels for construction equipment and hazardous substances which will be used during construction:

The following fuels and/or hazardous substances will be stored on the site: Used Oil, Hydraulic Fluid, Motor Oil, Antifreeze, and DEF

These fuels and/or hazardous substances will be stored in:

- Aboveground storage tanks with a cumulative storage capacity of less than 250 gallons will be stored on the site for less than one (1) year.

- Aboveground storage tanks with a cumulative storage capacity between 250 gallons and 499 gallons will be stored on the site for less than one (1) year.
- Aboveground storage tanks with a cumulative storage capacity of 500 gallons or more will be stored on the site. An Aboveground Storage Tank Facility Plan application must be submitted to the appropriate regional office of the TCEQ prior to moving the tanks onto the project.
- Fuels and hazardous substances will not be stored on the site.
- 2. **Attachment A - Spill Response Actions.** A site specific description of the measures to be taken to contain any spill of hydrocarbons or hazardous substances is attached.
- 3. Temporary aboveground storage tank systems of 250 gallons or more cumulative storage capacity must be located a minimum horizontal distance of 150 feet from any domestic, industrial, irrigation, or public water supply well, or other sensitive feature.
- 4. **Attachment B - Potential Sources of Contamination.** A description of any activities or processes which may be a potential source of contamination affecting surface water quality is attached.

Sequence of Construction

- 5. **Attachment C - Sequence of Major Activities.** A description of the sequence of major activities which will disturb soils for major portions of the site (grubbing, excavation, grading, utilities, and infrastructure installation) is attached.
 - For each activity described, an estimate (in acres) of the total area of the site to be disturbed by each activity is given.
 - For each activity described, include a description of appropriate temporary control measures and the general timing (or sequence) during the construction process that the measures will be implemented.
- 6. Name the receiving water(s) at or near the site which will be disturbed or which will receive discharges from disturbed areas of the project: [Guadalupe River](#)

Temporary Best Management Practices (TBMPs)

Erosion control examples: tree protection, interceptor swales, level spreaders, outlet stabilization, blankets or matting, mulch, and sod. Sediment control examples: stabilized construction exit, silt fence, filter dikes, rock berms, buffer strips, sediment traps, and sediment basins. Please refer to the Technical Guidance Manual for guidelines and specifications. All structural BMPs must be shown on the site plan.

- 7. **Attachment D – Temporary Best Management Practices and Measures.** TBMPs and measures will prevent pollution of surface water, groundwater, and stormwater. The construction-phase BMPs for erosion and sediment controls have been designed to retain sediment on site to the extent practicable. The following information is attached:

- A description of how BMPs and measures will prevent pollution of surface water, groundwater or stormwater that originates upgradient from the site and flows across the site.
 - A description of how BMPs and measures will prevent pollution of surface water or groundwater that originates on-site or flows off site, including pollution caused by contaminated stormwater runoff from the site.
 - A description of how BMPs and measures will prevent pollutants from entering surface streams, sensitive features, or the aquifer.
 - A description of how, to the maximum extent practicable, BMPs and measures will maintain flow to naturally-occurring sensitive features identified in either the geologic assessment, TCEQ inspections, or during excavation, blasting, or construction.
8. The temporary sealing of a naturally-occurring sensitive feature which accepts recharge to the Edwards Aquifer as a temporary pollution abatement measure during active construction should be avoided.
- Attachment E - Request to Temporarily Seal a Feature.** A request to temporarily seal a feature is attached. The request includes justification as to why no reasonable and practicable alternative exists for each feature.
 - There will be no temporary sealing of naturally-occurring sensitive features on the site.
9. **Attachment F - Structural Practices.** A description of the structural practices that will be used to divert flows away from exposed soils, to store flows, or to otherwise limit runoff discharge of pollutants from exposed areas of the site is attached. Placement of structural practices in floodplains has been avoided.
10. **Attachment G - Drainage Area Map.** A drainage area map supporting the following requirements is attached:
- For areas that will have more than 10 acres within a common drainage area disturbed at one time, a sediment basin will be provided.
 - For areas that will have more than 10 acres within a common drainage area disturbed at one time, a smaller sediment basin and/or sediment trap(s) will be used.
 - For areas that will have more than 10 acres within a common drainage area disturbed at one time, a sediment basin or other equivalent controls are not attainable, but other TBMPs and measures will be used in combination to protect down slope and side slope boundaries of the construction area.
 - There are no areas greater than 10 acres within a common drainage area that will be disturbed at one time. A smaller sediment basin and/or sediment trap(s) will be used in combination with other erosion and sediment controls within each disturbed drainage area.

- There are no areas greater than 10 acres within a common drainage area that will be disturbed at one time. Erosion and sediment controls other than sediment basins or sediment traps within each disturbed drainage area will be used.
11. **Attachment H - Temporary Sediment Pond(s) Plans and Calculations.** Temporary sediment pond or basin construction plans and design calculations for a proposed temporary BMP or measure have been prepared by or under the direct supervision of a Texas Licensed Professional Engineer. All construction plans and design information must be signed, sealed, and dated by the Texas Licensed Professional Engineer. Construction plans for the proposed temporary BMPs and measures are attached.
- N/A
12. **Attachment I - Inspection and Maintenance for BMPs.** A plan for the inspection of each temporary BMP(s) and measure(s) and for their timely maintenance, repairs, and, if necessary, retrofit is attached. A description of the documentation procedures, recordkeeping practices, and inspection frequency are included in the plan and are specific to the site and/or BMP.
13. All control measures must be properly selected, installed, and maintained in accordance with the manufacturer's specifications and good engineering practices. If periodic inspections by the applicant or the executive director, or other information indicate a control has been used inappropriately, or incorrectly, the applicant must replace or modify the control for site situations.
14. If sediment escapes the construction site, off-site accumulations of sediment must be removed at a frequency sufficient to minimize offsite impacts to water quality (e.g., fugitive sediment in street being washed into surface streams or sensitive features by the next rain).
15. Sediment must be removed from sediment traps or sedimentation ponds not later than when design capacity has been reduced by 50%. A permanent stake will be provided that can indicate when the sediment occupies 50% of the basin volume.
16. Litter, construction debris, and construction chemicals exposed to stormwater shall be prevented from becoming a pollutant source for stormwater discharges (e.g., screening outfalls, picked up daily).

Soil Stabilization Practices

Examples: establishment of temporary vegetation, establishment of permanent vegetation, mulching, geotextiles, sod stabilization, vegetative buffer strips, protection of trees, or preservation of mature vegetation.

17. **Attachment J - Schedule of Interim and Permanent Soil Stabilization Practices.** A schedule of the interim and permanent soil stabilization practices for the site is attached.

18. Records must be kept at the site of the dates when major grading activities occur, the dates when construction activities temporarily or permanently cease on a portion of the site, and the dates when stabilization measures are initiated.
19. Stabilization practices must be initiated as soon as practicable where construction activities have temporarily or permanently ceased.

Administrative Information

20. All structural controls will be inspected and maintained according to the submitted and approved operation and maintenance plan for the project.
21. If any geologic or manmade features, such as caves, faults, sinkholes, etc., are discovered, all regulated activities near the feature will be immediately suspended. The appropriate TCEQ Regional Office shall be immediately notified. Regulated activities must cease and not continue until the TCEQ has reviewed and approved the methods proposed to protect the aquifer from any adverse impacts.
22. Silt fences, diversion berms, and other temporary erosion and sediment controls will be constructed and maintained as appropriate to prevent pollutants from entering sensitive features discovered during construction.



Section 5: Temporary Stormwater Section (TCEQ-0602)

ATTACHMENT A

Comal Iron and Metals – Spill Response Actions

All operations employees have been trained on spill response measures. Spill kits are located strategically throughout the facility and contain different types of absorbent material for various media. The kits are checked daily and a formal inspection of the kits is completed on a monthly basis. Drums and 5-gallon buckets are kept onsite to collect spent absorbent for proper disposal via a contracted company.

Should a spill occur, employees should take action to contain the spill. Employees shall use the appropriate absorbent material for the media type from their spill kit to absorb the spill (kitty litter, absorbent pads, sock booms, etc.).

In the event of an uncontained spill, employees should utilize all absorbent material at their disposal, including equipment to construct earth berms around the affected area.

Spent absorbent material used to clean up the spill should be collected and stored in closed drums until they can be appropriately disposed of. All spills larger than 5 gallons should be logged and reported to the proper authority.

Edward's Aquifer Authority (210)-222-2204
TCEQ Regional Office (512)339-2929
National Response Center (800)424-8802



In accordance with the Edwards Aquifer Technical Guidance on Best Management Practices, the following steps will help reduce the stormwater impacts of leaks and spills:

Education

- Be aware that different materials pollute in different amounts. Make sure that each employee knows what a “significant spill” is for each material they use, and what is the appropriate response for “significant” and “insignificant” spills. Employees should also be aware of when a spill must be reported to the TCEQ. Information available in 30 TAC 327.4 and 40 CFR 302.4.
- Educate employees and subcontractors on potential dangers to humans and the environment from spills and leaks.
- Hold regular meetings to discuss and reinforce appropriate disposal procedures (incorporate into regular safety meetings).
- Establish a continuing education program to indoctrinate new employees.
- Have contractor’s superintendent or representative oversee and enforce proper spill prevention and control measures.

General Measures

- To the extent that the work can be accomplished safely, spills of oil, petroleum products, substances listed under 40 CFR parts 110,117, and 302, and sanitary and septic wastes should be contained and cleaned up immediately.
- Store hazardous materials and wastes in covered containers and protect from vandalism.
- Place a stockpile of spill cleanup materials where it will be readily accessible.
- Train employees in spill prevention and cleanup.
- Designate responsible individuals to oversee and enforce control measures. Spills should be covered and protected from stormwater runoff during rainfall to the extent that it doesn’t compromise clean up activities. Do not bury or wash spills with water.
- Store and dispose of used clean up materials, contaminated materials, and recovered spill material that is no longer suitable for the intended purpose in conformance with the provisions in applicable BMPs.
- Do not allow water used for cleaning and decontamination to enter storm drains or watercourses. Collect and dispose of contaminated water in accordance with applicable regulations.
- Contain water overflow or minor water spillage and do not allow it to discharge into drainage facilities or watercourses.
- Place Safety Data Sheets (SDS), as well as proper storage, cleanup, and spill reporting instructions for hazardous materials stored or used on the project site in an open, conspicuous, and accessible location.

- Keep waste storage areas clean, well organized, and equipped with ample cleanup supplies as appropriate for the materials being stored. Perimeter controls, containment structures, covers, and liners should be repaired or replaced as needed to maintain proper function.

Cleanup

- Clean up leaks and spills immediately.
- Use a rag for small spills on paved surfaces, a damp mop for general cleanup, and absorbent material for larger spills. If the spilled material is hazardous, then the used cleanup materials are also hazardous and must be disposed of as hazardous waste.
- Never hose down or bury dry material spills. Clean up as much of the material as possible and dispose of properly. See the waste management BMPs in this section for specific information.

Minor Spills

- Minor spills typically involve small quantities of oil, gasoline, paint, etc. which can be controlled by the first responder at the discovery of the spill.
- Use absorbent materials on small spills.
- Absorbent materials should be promptly removed and disposed of properly.
- Follow the practice below for a minor spill:
- Contain the spread of the spill.
- Recover spilled materials.
- Clean the contaminated area and properly dispose of contaminated materials.

Semi-Significant Spills

- Semi-significant spills still can be controlled by the first responder along with the aid of other personnel such as laborers and the foreman, etc. This response may require the cessation of all other activities. Spills should be cleaned up immediately:
- Contain spread of the spill.
- Notify the project foreman immediately.
- If the spill occurs on paved or impermeable surfaces, clean up using "dry" methods (absorbent materials, cat litter and/or rags). Contain the spill by encircling with absorbent materials and do not let the spill spread widely.
- If the spill occurs in dirt areas, immediately contain the spill by constructing an earthen dike. Dig up and properly dispose of contaminated soil.
- If the spill occurs during rain, cover spill with tarps or other material to prevent contaminating runoff.

Significant/Hazardous Spills

- For significant or hazardous spills that are in reportable quantities:
- Notify the TCEQ by telephone as soon as possible and within 24 hours at 512- 339-2929 (Austin) or 210-490-3096 (San Antonio) between 8 AM and 5 PM. After hours, contact the Environmental Release Hotline at 1-800-832-8224. It is the contractor's responsibility to have all emergency phone numbers at the project site.
- For spills of federal reportable quantities, in conformance with the requirements in 40 CFR parts 110,119, and 302, the contractor should notify the National Response Center at (800) 424-8802.
- Notification should first be made by telephone and followed up with a written report.
- The services of a spills contractor or a Haz-Mat team should be obtained immediately. Construction personnel should not attempt to clean up until the appropriate and qualified staff have arrived at the job site.
- Other agencies which may need to be consulted include, but are not limited to, the City Police Department, County Sheriff Office, Fire Departments, etc.



Section 5: Temporary Stormwater Section (TCEQ-0602)

ATTACHMENT B

Comal Iron and Metals – Potential Sources of Contamination

Potential Sources of Pollutants

- Equipment used to operate the metal recycling facility include shop vehicles, delivery trucks, forklifts, loaders, tractors, or other heavy equipment;
- Metals from turnings;
- Suspended solids from whitegoods;
- Assorted fluids from incoming material or company equipment;
- Portable toilet spills.



Section 5: Temporary Stormwater Section (TCEQ-0602)

ATTACHMENT C

Comal Iron and Metals – Sequence of Major Activities

The site currently has a grassy swale, with check dams, and silt fencing that spans the fence line and will remain until the permanent BMPs have been implemented. The proposed permanent BMP submitted with this application is the Contech Jellyfish Filter. The activity associated with the installation of this system will begin once the application is approved and will span an area of approximately 0.03 acres. Contractors with experience installing this type of system will be used for the duration of the installation. The entire installation should take anywhere from 6-8 weeks from the time approval is granted. The Guadalupe River is the receiving water for the area. The following general steps will be taken to complete the project:

- **Excavation:** Excavate the site to the required depth and size as per the installation plan provided by the manufacturer. The excavation should be performed in accordance with the site-specific soil conditions and should include backfilling with suitable materials if necessary.
- **Setting the Base:** Set the base of the filter unit in the excavation and ensure that it is level and stable. Follow the manufacturer's instructions for proper placement and orientation of the base.
- **Installation of the Filter Cartridge:** Install the filter cartridge onto the base unit according to the manufacturer's instructions. This may involve attaching the cartridge to the base, inserting the appropriate screening media and securing it in place.
- **Backfilling:** Backfill the excavated area around the filter unit with suitable backfill material, compacting it in lifts to ensure that the unit is stable.
- **Final Inspection and Testing:** Inspect the installation to ensure that all components are properly installed, and there are no leaks or other issues. Test the unit to ensure it is operating correctly and that it meets the required performance specifications.
- **Ongoing Maintenance:** Schedule regular maintenance to ensure that the filter unit continues to operate efficiently. This may involve inspecting, cleaning, and replacing filter cartridges as necessary, among other activities.



Section 5: Temporary Stormwater Section (TCEQ-0602)

ATTACHMENT D

Comal Iron and Metals – Temporary Best Management Practices and Measures

The property slopes south, and all water runs through the property and exits through outfall 001. The natural flow of the water runs along the east fence line and is controlled by the following temporary controls:

- A two (2) foot berm spans the fence line and is lined with erosion control blankets for additional stabilization.
- Along the berm is a grassy swale with check dams approximately every 25 feet. The check dams provide filtration and stability for the fast-flowing water during storm events.
- A gabion is situated directly in front of the outfall point as an additional measure.
- Silt fencing is situated on the western edge of the swale for additional filtration
- A water truck is used throughout the facility for dust control to prevent blowing and movement of sediment and reduce tracking.

Water run-on from the neighboring property is not a concern at this time. The area is undisturbed and has plenty of trees and vegetation for cover to reduce the flow rate of water, and there are no known pollutants stored or used in the area.



Section 5: Temporary Stormwater Section (TCEQ-0602)

ATTACHMENT E

Comal Iron and Metals – Request to Temporarily Seal a Feature

This attachment does not apply to this submittal. There will not be any sealed features at the project site.



Section 5: Temporary Stormwater Section (TCEQ-0602)

ATTACHMENT F

Comal Iron and Metals – Structural Practices

The project site uses roll-off containers, box trucks, and a concrete pad to contain materials and reduce the likelihood of exposure. The sloped elevation towards the outfall will guide the water towards the silt fencing and into the grassy swale. And through the check dams. Since the implementation of these temporary controls there has been no discharge from the property.



Section 5: Temporary Stormwater Section (TCEQ-0602)

ATTACHMENT G

Comal Iron and Metals – Drainage Area Map

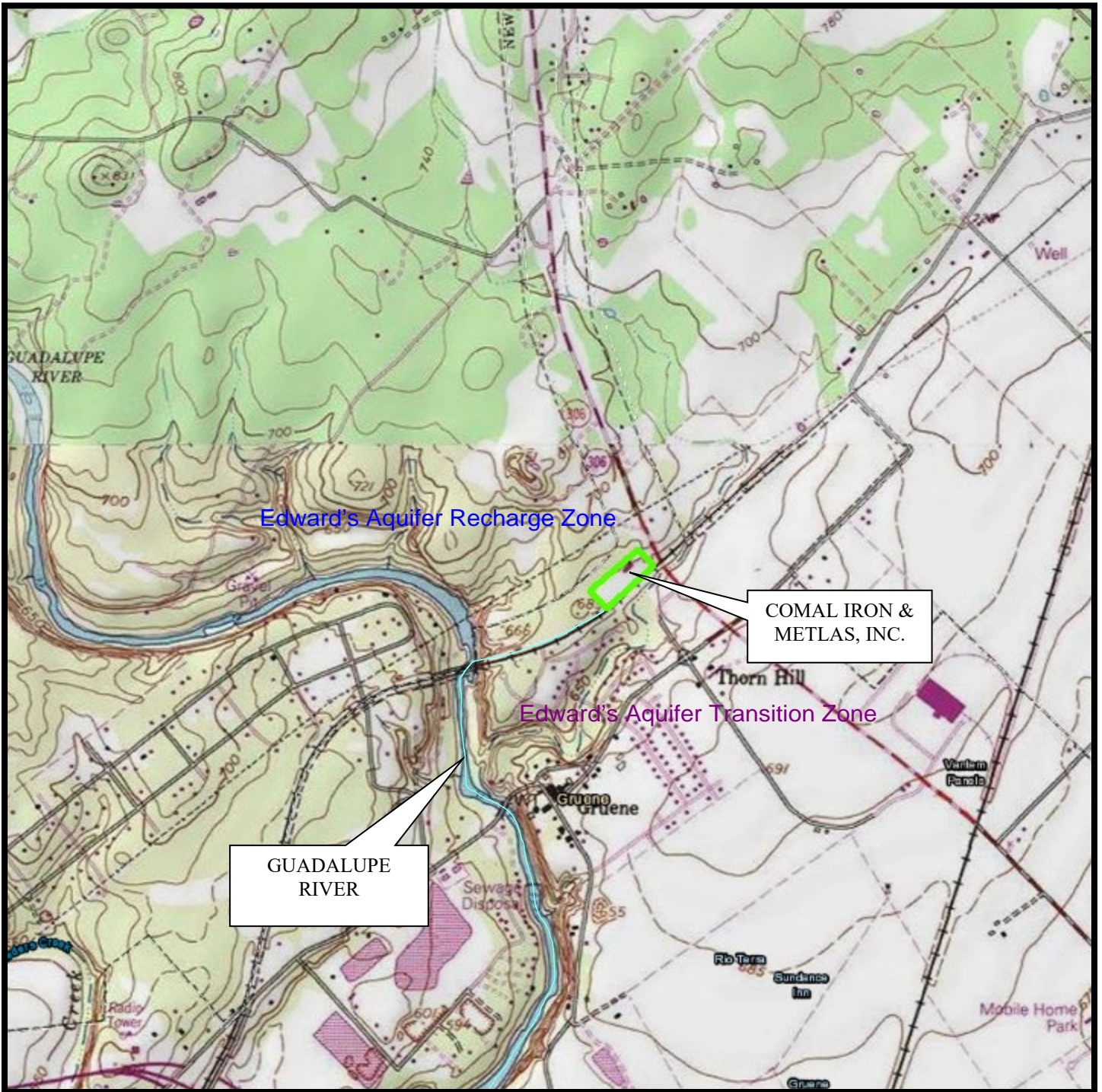

Edward's Aquifer Recharge Zone

COMAL IRON & METLAS, INC.

Edward's Aquifer Transition Zone

GUADALUPE RIVER

SITE LOCATION MAP

USGS Topographic Map

511-777

FIGURE 1

DATE 09/22
MH

James
Environmental
Management, Inc.

GEORGETOWN, TX

COMAL IRON & METALS, INC.

NEW BRAUNFELS, TEXAS

SCALE: 1"=2000'



Section 5: Temporary Stormwater Section (TCEQ-0602)

ATTACHMENT H

Comal Iron and Metals – Temporary Sediment Pond(s) Plans and Calculations

This attachment does not apply to this submittal. There will not be a sediment pond at the project site.



Section 5: Temporary Stormwater Section (TCEQ-0602)

ATTACHMENT I

Comal Iron and Metals – Inspection and Maintenance for BMPs

At a minimum, weekly inspections will be used to document any deficiencies with the BMPs. Daily informal inspections will also be conducted. Formal logged inspections are completed on a monthly basis by a third-party contractor.

Inspection and Maintenance Guidelines:

- Swales should be inspected weekly and after each rain event to determine if silt is building up behind the silt fencing and gabian, or if erosion is occurring along the swale. Locate and repair any damage to the swale or silt fencing, clear debris, or other obstructions so as not to diminish flow capacity.
- Silt should be removed in a timely manner to prevent remobilization and to maintain the effectiveness of the control.
- If erosion occurs along the swale, the slopes of the should be stabilized through mulch or seeding.
- Damage from storms, normal activities, or disturbance of swale stabilization, should be repaired as soon as practical.



Section 5: Temporary Stormwater Section (TCEQ-0602)

ATTACHMENT J

Comal Iron and Metals – Schedule of Interim and Permanent Soil Stabilization Practices

All control measures must be properly selected, installed, and maintained in accordance with the manufacturer's specifications and good engineering practices. If sediment escapes the project site, off-site accumulations of sediment is removed at a frequency sufficient to minimize offsite impacts to water quality. Additionally, litter, debris, or chemicals exposed to stormwater shall be prevented from becoming a pollutant source for stormwater discharges. Routine inspections ensure the control measures remain in place, off-site tracking is minimized, and debris is removed from areas that could impact offsite water quality.

The temporary measures include, an erosion control blanket is situated on the berm that spans the eastern fence line to provide additional stability and reduce the likelihood of erosion. Grass growth is encouraged along the yard's perimeter but within the fence as an additional stabilization measure.



Section 6

Comal Iron and Metals – Permanent Stormwater Section (TCEQ - 0600)

Permanent stormwater controls have not been approved for the facility.

Permanent Stormwater Section

Texas Commission on Environmental Quality

for Regulated Activities on the Edwards Aquifer Recharge Zone and Relating to 30 TAC §213.5(b)(4)(C), (D)(li), (E), and (5), Effective June 1, 1999

To ensure that the application is administratively complete, confirm that all fields in the form are complete, verify that all requested information is provided, consistently reference the same site and contact person in all forms in the application, and ensure forms are signed by the appropriate party.

Note: Including all the information requested in the form and attachments contributes to more streamlined technical reviews.

Signature

To the best of my knowledge, the responses to this form accurately reflect all information requested concerning the proposed regulated activities and methods to protect the Edwards Aquifer. This **Permanent Stormwater Section** is hereby submitted for TCEQ review and executive director approval. The application was prepared by:

Print Name of Customer/Agent: Comal Iron and Metals/Adriana Lee

Date: 10/11/2022

Signature of Customer/Agent



Regulated Entity Name: Comal Iron and Metals

Permanent Best Management Practices (BMPs)

Permanent best management practices and measures that will be used during and after construction is completed.

- Permanent BMPs and measures must be implemented to control the discharge of pollution from regulated activities after the completion of construction.
 N/A
- These practices and measures have been designed, and will be constructed, operated, and maintained to insure that 80% of the incremental increase in the annual mass loading of total suspended solids (TSS) from the site caused by the regulated activity is removed. These quantities have been calculated in accordance with technical guidance prepared or accepted by the executive director.
 The TCEQ Technical Guidance Manual (TGM) was used to design permanent BMPs and measures for this site.

A technical guidance other than the TCEQ TGM was used to design permanent BMPs and measures for this site. The complete citation for the technical guidance that was used is: _____

N/A

3. Owners must insure that permanent BMPs and measures are constructed and function as designed. A Texas Licensed Professional Engineer must certify in writing that the permanent BMPs or measures were constructed as designed. The certification letter must be submitted to the appropriate regional office within 30 days of site completion.

N/A

4. Where a site is used for low density single-family residential development and has 20 % or less impervious cover, other permanent BMPs are not required. This exemption from permanent BMPs must be recorded in the county deed records, with a notice that if the percent impervious cover increases above 20% or land use changes, the exemption for the whole site as described in the property boundaries required by 30 TAC §213.4(g) (relating to Application Processing and Approval), may no longer apply and the property owner must notify the appropriate regional office of these changes.

The site will be used for low density single-family residential development and has 20% or less impervious cover.

The site will be used for low density single-family residential development but has more than 20% impervious cover.

The site will not be used for low density single-family residential development.

5. The executive director may waive the requirement for other permanent BMPs for multi-family residential developments, schools, or small business sites where 20% or less impervious cover is used at the site. This exemption from permanent BMPs must be recorded in the county deed records, with a notice that if the percent impervious cover increases above 20% or land use changes, the exemption for the whole site as described in the property boundaries required by 30 TAC §213.4(g) (relating to Application Processing and Approval), may no longer apply and the property owner must notify the appropriate regional office of these changes.

Attachment A - 20% or Less Impervious Cover Waiver. The site will be used for multi-family residential developments, schools, or small business sites and has 20% or less impervious cover. A request to waive the requirements for other permanent BMPs and measures is attached.

The site will be used for multi-family residential developments, schools, or small business sites but has more than 20% impervious cover.

The site will not be used for multi-family residential developments, schools, or small business sites.

6. **Attachment B - BMPs for Upgradient Stormwater.**

- A description of the BMPs and measures that will be used to prevent pollution of surface water, groundwater, or stormwater that originates upgradient from the site and flows across the site is attached.
 - No surface water, groundwater or stormwater originates upgradient from the site and flows across the site, and an explanation is attached.
 - Permanent BMPs or measures are not required to prevent pollution of surface water, groundwater, or stormwater that originates upgradient from the site and flows across the site, and an explanation is attached.
7. **Attachment C - BMPs for On-site Stormwater.**
- A description of the BMPs and measures that will be used to prevent pollution of surface water or groundwater that originates on-site or flows off the site, including pollution caused by contaminated stormwater runoff from the site is attached.
 - Permanent BMPs or measures are not required to prevent pollution of surface water or groundwater that originates on-site or flows off the site, including pollution caused by contaminated stormwater runoff, and an explanation is attached.
8. **Attachment D - BMPs for Surface Streams.** A description of the BMPs and measures that prevent pollutants from entering surface streams, sensitive features, or the aquifer is attached. Each feature identified in the Geologic Assessment as sensitive has been addressed.
- N/A
9. The applicant understands that to the extent practicable, BMPs and measures must maintain flow to naturally occurring sensitive features identified in either the geologic assessment, executive director review, or during excavation, blasting, or construction.
- The permanent sealing of or diversion of flow from a naturally-occurring sensitive feature that accepts recharge to the Edwards Aquifer as a permanent pollution abatement measure has not been proposed.
 - Attachment E - Request to Seal Features.** A request to seal a naturally-occurring sensitive feature, that includes, for each feature, a justification as to why no reasonable and practicable alternative exists, is attached.
10. **Attachment F - Construction Plans.** All construction plans and design calculations for the proposed permanent BMP(s) and measures have been prepared by or under the direct supervision of a Texas Licensed Professional Engineer, and are signed, sealed, and dated. The plans are attached and, if applicable include:
- Design calculations (TSS removal calculations)
 - TCEQ construction notes
 - All geologic features
 - All proposed structural BMP(s) plans and specifications
- N/A

11. **Attachment G - Inspection, Maintenance, Repair and Retrofit Plan.** A plan for the inspection, maintenance, repairs, and, if necessary, retrofit of the permanent BMPs and measures is attached. The plan includes all of the following:
- Prepared and certified by the engineer designing the permanent BMPs and measures
 - Signed by the owner or responsible party
 - Procedures for documenting inspections, maintenance, repairs, and, if necessary retrofit
 - A discussion of record keeping procedures
- N/A
12. **Attachment H - Pilot-Scale Field Testing Plan.** Pilot studies for BMPs that are not recognized by the Executive Director require prior approval from the TCEQ. A plan for pilot-scale field testing is attached.
- N/A
13. **Attachment I -Measures for Minimizing Surface Stream Contamination.** A description of the measures that will be used to avoid or minimize surface stream contamination and changes in the way in which water enters a stream as a result of the construction and development is attached. The measures address increased stream flashing, the creation of stronger flows and in-stream velocities, and other in-stream effects caused by the regulated activity, which increase erosion that results in water quality degradation.
- N/A

Responsibility for Maintenance of Permanent BMP(s)

Responsibility for maintenance of best management practices and measures after construction is complete.

14. The applicant is responsible for maintaining the permanent BMPs after construction until such time as the maintenance obligation is either assumed in writing by another entity having ownership or control of the property (such as without limitation, an owner's association, a new property owner or lessee, a district, or municipality) or the ownership of the property is transferred to the entity. Such entity shall then be responsible for maintenance until another entity assumes such obligations in writing or ownership is transferred.
- N/A
15. A copy of the transfer of responsibility must be filed with the executive director at the appropriate regional office within 30 days of the transfer if the site is for use as a multiple single-family residential development, a multi-family residential development, or a non-residential development such as commercial, industrial, institutional, schools, and other sites where regulated activities occur.
- N/A



Section 6: Comal Iron and Metals – Permanent Stormwater Section
(TCEQ - 0600)

ATTACHMENT A

Comal Iron and Metals – 20% or Less Impervious Cover Waiver

This attachment does not apply to this submittal. No impervious cover waivers are proposed at this time.



Section 6: Comal Iron and Metals – Permanent Stormwater Section (TCEQ - 0600)

ATTACHMENT B

Comal Iron and Metals – BMPs for Upgradient Stormwater

This attachment does not apply to this submittal. No BMPs for upgradient stormwater are proposed at this time. The facility has berms along the fence throughout the property to prevent upgradient runoff. Additionally, the area upgradient is undisturbed residential land that would not impact the stormwater to be discharged by the facility.



Section 6: Comal Iron and Metals – Permanent Stormwater Section (TCEQ - 0600)

ATTACHMENT C

Comal Iron and Metals – BMPs for On-site Stormwater

A description of the BMPs and measures that will be used to prevent pollution of surface water or groundwater that originates on-site or flows off the site, including pollution caused by contaminated stormwater runoff from the site is attached.

SECTION (____)
JELLYFISH® MEMBRANE FILTRATION SYSTEM
STORMWATER QUALITY – MEMBRANE FILTRATION SYSTEM STANDARD SPECIFICATION

1. GENERAL

1.1. The Contractor shall furnish and install the Jellyfish, complete and operable as shown and as specified herein, in accordance with the requirements of the plans and contract documents. The water quality treatment flow shall be as determined and approved by the Engineer of Record. The Jellyfish system removes pollutants from stormwater runoff through the unit operations of sedimentation, floatation, and membrane filtration.

1.2. The Jellyfish shall be of a type that has been installed and in use for a minimum of five (5) consecutive years preceding the date of installation of the system. The manufacturer shall have been, during the same consecutive five (5) year period, engaged in the engineering design and production of systems deployed for the treatment of storm water runoff and which have a history of successful production, acceptable to the Engineer of Record and/or the approving Jurisdiction. The manufacturer of the Jellyfish shall be, without exception:

Contech Engineered Solutions
9100 Centre Pointe Drive
West Chester, OH, 45069
Tel: 1 800 338 1122

1.3. Submittals: Shop drawings for the structure and performance are to be submitted with each order to the contractor. Contractor shall forward shop drawing submittal to the consulting engineer for approval. Shop drawings are to detail the structure precast concrete and call out or note the internals/components.

1.4. Product Substitutions: Any proposed product substitution to this specifications must be submitted for review and approved 10 days prior to project bid date by the Engineer of Record. Review package should include third party reviewed performance data for both flow rate and pollutant removal. Contractor to coordinate with the Engineer of Record any applicable modifications to the project estimates of cost, bonding amount determinations, plan check fees for changes to approved documents, and/or any other regulatory requirements resulting from the product substitution.

1.5. American Society for Testing and Materials (ASTM) Reference Specifications:

1.5.1. ASTM C891: Standard Specification for Installation of Underground Precast Concrete Utility Structures

1.5.2. ASTM C478: Standard Specification for Precast Reinforced Concrete Manhole Sections

1.5.3. ASTM C858: Standard Specification of Underground Precast Concrete Utility Structures

1.5.4.ASTM C857: Standard Practice for Minimum Structural Design Loading for Underground Precast Concrete Utility Structures

1.5.5.ASTM C990: Standard Specification for Joints for Concrete Manholes Using Preformed Flexible Joint Sealants

1.5.6.ASTM D4101: Standard Specification for Copolymer steps construction

1.5.7.ASTM D4097: Standard Specification for Contact-Molded Glass-Fiber-Reinforced Thermoset Resin Corrosion-Resistant

2. MATERIALS

2.1. Precast Concrete Structure: The device shall be an all concrete structure (including risers), constructed from precast concrete riser and slab components or monolithic precast structure(s). Precast concrete vault shall be provided according to ASTM C857 and C858 and manholes shall be provided according to ASTM C478. Both structure types shall be installed to conform to ASTM C891 and to any required state highway, municipal or local specifications; whichever is more stringent. All precast concrete components shall be manufactured to a minimum live load of HS-20 truck loading or greater based on local regulatory specifications, unless otherwise modified or specified by the design engineer.

2.2. Gaskets: Gaskets and/or sealants shall be used to seal between concrete joints. Joints shall be sealed with preformed joint sealing compound conforming to ASTM C990.

2.3. Internal Components:

2.3.1. Cartridge Deck: The deck insert shall be bolted and sealed inside the precast concrete chamber. The insert shall serve as: (a) a horizontal divider between the lower treatment zone and the upper treated effluent zone; (b) a deck for attachment of filter cartridges such that the membrane filter elements of each cartridge extend into the lower treatment zone; (c) a platform for maintenance workers to service the filter cartridges; (c) a conduit for conveyance of treated water to the effluent pipe.

2.3.1.1. Fiberglass: In cylindrical configurations, the fiberglass portions of the filter device shall be constructed in accordance with the following standard: ASTM D4097: Contact Molded Glass Fiber Reinforced Chemical Resistant Tanks.

2.3.1.2. Aluminum: In rectangular configurations, the aluminum cartridge deck shall be ¼" thick, 5052-H32 Aluminum with all welds to be 100% continuous waterproof weld using 5356 filler.

2.3.2. Membrane Filter Cartridges: Filter cartridges shall be comprised of reusable cylindrical membrane filter elements connected to a perforated head plate. The number of membrane filter elements per cartridge shall be a minimum of eleven 2.75-inch (70-mm) or greater diameter elements. The length of each filter element

shall be a minimum 15 inches (381 mm). Each cartridge shall be fitted into the cartridge deck by insertion into a cartridge receptacle that is permanently mounted into the cartridge deck. Each cartridge shall be secured by a cartridge lid that is threaded onto the receptacle, or similar mechanism to secure the cartridge into the deck. The maximum treatment flow rate of a filter cartridge shall be controlled by an orifice in the cartridge lid, or on the individual cartridge itself, and based on a design flux rate (surface loading rate) determined by the maximum treatment flow rate per unit of filtration membrane surface area. The maximum design flux rate shall be 0.21 gpm/ft² (0.142 lps/m²).

2.3.3. Each membrane filter cartridge shall allow for manual installation and removal. Each filter cartridge shall contain no less than 7 ft² of surface area per inch of length and have filtration membrane surface area and dry installation weight as follows (if length of filter cartridge is between those listed below, the surface area and weight shall be proportionate to the next length shorter and next length longer as shown below):

Filter Cartridge Length (in)	Minimum Filtration Membrane Surface Area (ft ² / m ²)	Maximum Filter Cartridge Dry Weight (lbs / kg)
15 / 381	106 / 9.8	10.0 / 4.5
27 / 686	190 / 17.7	14.5 / 6.6
40 / 1016	282 / 26.2	19.5 / 8.9
54 / 1372	381 / 35.4	25.0 / 11.4

2.3.4. Backwashing Cartridges: The filter device shall have a weir extending above the cartridge deck, or other mechanism, that encloses the high flow rate filter cartridges when placed in their respective cartridge receptacles within the cartridge deck. The weir, or other mechanism, shall collect a pool of filtered water during inflow events that backwashes the high flow rate cartridges when the inflow event subsides. All filter cartridges and membranes shall be reusable and allow for the use of filtration membrane rinsing procedures to restore flow capacity and sediment capacity; extending cartridge service life.

2.3.5. Maintenance Access to Captured Pollutants: The filter device shall contain an opening(s) that provides maintenance access for removal of accumulated floatable pollutants and sediment, removal of and replacement of filter cartridges, cleaning of the sump, and rinsing of the deck. Access shall have a minimum clear height over all of the filter cartridges (length of cartridge + 6 inches), or be accessible by a hatch or other mechanism that provides vertical clear space over all of the filter cartridges such that the cartridges can be lifted straight vertically out of the receptacles and deck for the entire length of the cartridge.

2.3.6. Baffle: The filter device shall provide a baffle that extends from the underside of the cartridge deck to a minimum length equal to the length of the membrane filter elements. The baffle shall serve to protect the membrane filter elements from

contamination by floatables and coarse sediment. The baffle shall be flexible and continuous in cylindrical configurations, and shall be a straight concrete or aluminum wall in rectangular configurations.

2.3.7.Sump: The device shall include a minimum 24 inches (610 mm) of sump below the bottom of the cartridges for sediment accumulation, unless otherwise specified by the design engineer. Depths less than 24 inches may have an impact on the total performance and/or longevity between cartridge maintenance/replacement of the device.

2.3.8.Steps: Steps shall be constructed according to ASTM D4101 of copolymer polypropylene, and be driven into preformed or pre-drilled holes after the concrete has cured, installed to conform to applicable sections of state, provincial and municipal building codes, highway, municipal or local specifications for the construction of such devices.

2.3.9.Double-Wall Containment of Hydrocarbons: The cylindrical precast concrete device shall provide double-wall containment for hydrocarbon spill capture by a combined means of an inner wall of fiberglass, to a minimum depth of 12 inches (305 mm) below the cartridge deck, and the precast vessel wall.

2.4.Bend Structure: The device shall be able to be used as a bend structure with minimum angles between inlet and outlet pipes of 90-degrees or less in the stormwater conveyance system.

2.5.Frame and Cover: Frame and covers must be manufactured from cast-iron or other composite material tested to withstand H-20 or greater design loads, and as approved by the local regulatory body. Frames and covers must be embossed with the Contech or the Jellyfish brand name.

2.6.Doors and Hatches: If provided shall meet designated loading requirements or at a minimum for incidental vehicular traffic.

3. PERFORMANCE

3.1.Function: The Jellyfish filter shall function to remove pollutants by the following unit treatment processes; sedimentation, floatation, and membrane filtration.

3.2.Pollutants: The Jellyfish filter shall remove oil, debris, trash, coarse and fine particulates, particulate-bound pollutants, metals and nutrients from stormwater during runoff events.

3.3.Bypass: The Jellyfish filter shall typically utilize an external bypass to divert excessive flows. Where an internal bypass is utilized, systems shall be equipped with a floatables baffle, and bypass water shall not pass through the treatment sump or cartridge filtration zone.

3.4.Treatment Flux Rate (Surface Loading Rate): The Jellyfish filter shall treat 100% of the required water quality treatment flow based on a maximum design flux rate (surface

loading rate) across the membrane filter cartridges not to exceed 0.21 gpm/ft² (0.142 lps/m²).

3.5. Field Testing: At a minimum, the Jellyfish filter shall have been field tested and verified with a minimum 25 qualifying storm events and field monitoring conducted according to the TARP Tier II or TAPE field test protocol, and have received NJCAT verification.

3.6. Suspended Solids Removal: The Jellyfish filter shall have demonstrated a minimum median TSS removal efficiency of 85% and a minimum median SSC removal efficiency of 95%.

3.7. Fine Particle Removal: The Jellyfish filter shall have demonstrated the ability to capture fine particles as indicated by a minimum median removal efficiency of 75% for the particle fraction less than 25 microns, an effluent d₅₀ of 15 microns or lower for all monitored storm events, and an effluent turbidity of 15 NTUs or lower.

3.8. Nutrient (Total Phosphorus & Total Nitrogen) Removal: The Jellyfish filter shall have demonstrated a minimum median Total Phosphorus removal of 55%, and a minimum median Total Nitrogen removal of 50%.

3.9. Metals (Total Zinc & Total Copper) Removal: The Jellyfish filter shall have demonstrated a minimum median Total Zinc removal of 50%, and a minimum median Total Copper removal of 75%.

4. EXECUTION

4.1. Handling and Storage: Prevent damage to materials during storage and handling.

4.2. Precast Concrete Structure: The installation of the precast concrete device should conform to ASTM C891 and to any state highway, municipal or local specification for the installation of underground precast concrete structures, whichever is more stringent. Selected sections of a general specification that are applicable are summarized below.

4.2.1. The precast concrete device is installed in sections in the following sequence:

- aggregate base
- base slab
- treatment chamber and cartridge deck riser section(s)
- bypass section
- connect inlet and outlet pipes
- concrete riser section(s) and/or transition slab (if required)
- maintenance riser section(s) (if required)
- frame and access cover

4.2.2. The precast base should be placed level at the specified grade. The entire base should be in contact with the underlying compacted granular material. Subsequent sections, complete with joint seals, should be installed in accordance with Contech's recommendations.

- 4.2.3. Adjustment of the Jellyfish filter can be performed by lifting the upper sections free of the excavated area, re-leveling the base, and re-installing the sections. Damaged sections and gaskets should be repaired or replaced as necessary to restore original condition and seals. Once the Jellyfish filter has been constructed, any/all lift holes must be plugged with mortar or non-shrink grout.
- 4.3. Inlet and Outlet Pipes: Inlet and outlet pipes should be securely set into the device using approved pipe seals (flexible boot connections, where applicable), and such that any pipe intrusion into the device does not impact the device functionality.
- 4.4. Frame and Cover Installation: Adjustment units (e.g. grade rings) should be installed to set the frame and cover at the required elevation. The adjustment units should be laid in a full bed of mortar with successive units being joined using sealant recommended by Contech. Frames for the cover should be set in a full bed of mortar at the elevation specified.
- 4.5. In some instances the Maintenance Access Wall, if provided, shall require an extension attachment and sealing to the precast wall and cartridge deck at the job site, rather than at the precast facility. In this instance, installation of these components shall be performed according to instructions provided by Contech.

5. ACTIVATION, INSPECTION AND MAINTENANCE

- 5.1. Filter cartridges shall be installed in the cartridge deck in accordance with the manufacturer's guidelines and recommendations. Contractor to contact the manufacturer to schedule cartridge delivery and review procedures/requirements to be completed to the device prior to installation of the cartridges and activation of the system.
- 5.2. Manufacturer shall coordinate delivery of filter cartridges and other internal components with contractor. Filter cartridges shall be installed after site is stabilized and/or unit is isolated from construction influent and ready to accept cartridges. Unit is ready to accept cartridges after it has been cleaned out and any standing water, debris, and other materials have been removed. Contractor shall take appropriate action to protect the filter cartridge receptacles and filter cartridges from damage during construction, and in accordance with the manufacturer's recommendations and guidance. For systems with cartridges installed prior to full site stabilization, the contractor shall plug inlet and outlet pipes to prevent stormwater and other influent from entering the device. Plugs are to be removed once the site is stabilized and unit is ready to receive stormwater runoff.
- 5.3. Durability of membranes are subject to good handling practices during inspection and maintenance (removal, rinsing, and reinsertion) events, and site specific conditions that may have heavier or lighter loading onto the cartridges, and pollutant variability that may impact the membrane structural integrity. Membrane maintenance and replacement shall be in accordance with Contech's recommendations.

- 5.4. Inspection; which includes trash and floatables collection, sediment depth determination, and visible determination of backwash pool depth; shall be easily conducted from grade (outside the structure).
- 5.5. Manual rinsing of the reusable filter cartridges shall promote restoration of the flow capacity and sediment capacity of the filter cartridges, extending cartridge service life.
- 5.6. The filter device shall have a minimum 12 inches (610 mm) of sediment storage depth, and a minimum of 12 inches between the top of the sediment storage and bottom of the filter cartridge tentacles, unless otherwise specified by the design engineer. Variances may have an impact on the total performance and/or longevity between cartridge maintenance/replacement of the device.
- 5.7. Sediment removal from the filter treatment device shall be able to be conducted using a standard maintenance truck and vacuum apparatus, and a minimum one point of entry to the sump that is unobstructed by filter cartridges.
- 5.8. Maintenance access shall have a minimum clear height over all of the filter cartridges (length of cartridge + 6 inches), or be accessible by a hatch or other mechanism that provides vertical clear space over all of the filter cartridges such that the cartridges can be lifted straight vertically out of the receptacles and deck for the entire length of the cartridge.
- 5.9. After construction and installation, and during operation, the device shall be inspected and cleaned as necessary based on Contech's recommended inspection and maintenance guidelines and the local regulatory agency/body.
- 5.10. When replacement membrane filter elements and/or other parts are required, only membrane filter elements and parts approved by Contech for use with the Jellyfish filter shall be installed.
- 5.11. Filter cartridges shall be able to be maintained without the use of additional lifting equipment.
- 5.12. Contech shall provide an Owner's Manual upon request.

END OF SECTION

This record serves as an acknowledgment of the project and required maintenance by the owner agents of the project, Marcie Rodriguez (CEO of Comal Iron and Metals), Johnnie Rodriguez (Land Owner), and Adriana Lee of James. Environmental Management, Inc.

Repair and Retrofit

Any repairs and retrofits to the Jellyfish should be completed by a Certified Maintenance Provider, which can be found on the Contech® website at:

<https://conteches.com/stormwater-management/maintenance-services/search>

Record Keeping

A copy of this IMRR Plan should be maintained at the facility by the Owner. Inspection and maintenance records shall be kept on file by the Owner for a period of at least three (3) years.

Repair and retrofit records should be kept on file by the Owner for at least five (5) years.

Appendix B of this IMRR Plan is provided as a placeholder to track completed Inspection and Maintenance Logs and any repair and retrofit records.

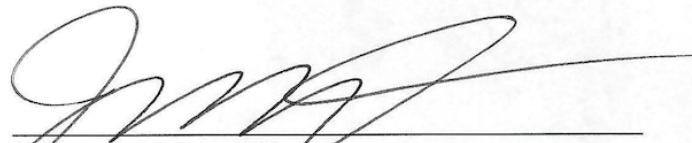

Signature of Owner/Agent

July 7-23
Date

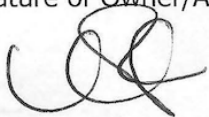

Signature of Owner/Agent

7.7.23
Date



Signature of Owner/Agent

06/30/2023
Date

SPECIFICATION FOR CORRUGATED METAL PIPE

ULTRA FLO[®] PIPE – GALVANIZED STEEL

1.0 GENERAL

- 1.1 This specification covers the manufacture and installation of the galvanized ULTRA FLO (UF) corrugated steel pipe or pipe arch (PA) detailed in the project plans.

2.0 DESIGN STANDARDS

- 2.1 The UF pipe or PA meets the design parameters of the American Association of State Highway and Transportation Officials (AASHTO) Standard Specification for Highway Bridges, AASHTO LRFD Bridge Design, and/or the American Iron and Steel Institute (AISI).

3.0 MATERIAL

- 3.1 The galvanized steel coils shall conform to the applicable requirements of AASHTO M 218 or ASTM A929.

4.0 PIPE

- 4.1 The UF pipe or PA shall be manufactured with the $\frac{3}{4}$ " X $\frac{3}{4}$ " X 7 $\frac{1}{2}$ " external ribs in accordance with the applicable requirements of AASHTO M 36 or ASTM A760. The pipe sizes and gauges shall be as shown on the project plans.
- 4.2 All fabrication of the product shall occur within the United States.

5.0 COUPLING BANDS

- 5.1 Coupling bands for the UF shall be made of the same base metal and coatings as the UF to a minimum of 18 gauge.
- 5.2 Ends of the UF are rerolled with annular corrugations for proper indexing.
- 5.3 Connection fasteners will be provided.

6.0 HANDLING & ASSEMBLY

- 6.1 Refer to the recommendations of the National Corrugated Steel Pipe Association's (NCSPA).

7.0 INSTALLATION

- 7.1 The installation shall be in accordance with AASHTO Standard Specifications for Highway Bridges, LRFD Section 26, Division II, NCSPA, or ASTM A798 and in conformance with the project plans and specifications. If there are any inconsistencies or conflicts, the contractor must bring them to the attention of the project engineer.
- 7.2 It is always the contractor's responsibility to follow OSHA guidelines for safe practices.

8.0 CONSTRUCTION LOADS

- 8.1 Construction loads may be greater than design loads. The contractor shall follow the recommendations for additional compacted material per manufacturer's or NCSPA guidelines.

DMS - 6200
FILTER FABRIC

EFFECTIVE DATE: MAY 2010

6200.1. Description. This Specification governs the sampling, testing, and material requirements of filter fabrics.

6200.2. Units of Measurements. The values given in parentheses (if provided) are not standard and may not be exact mathematical conversions. Use each system of units separately. Combining values from the two systems may result in nonconformance with the standard.

6200.3. Definitions.

A. Filter Fabric—a special fabric usually used in drainage applications to allow water flow without clogging or binding by soil particles.

1. **Type 1**—Type 1 is a standard weight fabric for retaining walls and soil separation.
2. **Type 2**—Type 2 is a high strength fabric for rock riprap or other severe use.

6200.4. Material Producer List. The Materials and Pavements Section of the Construction Division (CST/M&P) maintains a material producer list (MPL) of products conforming to this Specification. Materials on the MPL, entitled “[Silt Fence, Filter Fabric, and Fabric Underseal](#),” require no further testing unless deemed necessary by the Project Engineer or CST/M&P. Refer to DMS-6320 for further details on qualifying for the Quality Monitoring Program and obtaining a place on the MPL.

6200.5. Sampling and Testing. Sample in accordance with Tex-735-I. Perform testing in accordance with the test methods listed in Table 1.

6200.6. Material Requirements.

A. General Requirements. Both types of filter fabric have the following qualities:

- The fabric consists exclusively of manmade thermoplastic fibers, is a non-woven geotextile fabric, and forms a mat of uniform quality.
- Fabric fibers are continuous and random throughout the fabric.
- The fabric is mildew resistant and rot-proof, and it is satisfactory for use in a wet soil and aggregate environment.

B. Physical Requirements. The fabric must conform to the requirements listed in Table 1 when tested in accordance with the test methods specified.

Table 1
Filter Fabric Requirements

Physical Properties	Test Method	Type 1	Type 2
Fabric Weight, on an ambient temperature air-dried, tension-free sample.	Tex-616-J	136.0 g/m ² (4 oz/yd ²), minimum	203.0 g/m ² (6 oz/yd ²), minimum
Permittivity 1/sec.	ASTM D 4491	1.0, min	0.5, min
Tensile Strength, N	ASTM D 4632	445 N (100 lbs.) minimum	890 N (200 lbs.) minimum
Apparent Opening Size	ASTM D 4751	70-100	80-120
Elongation at yield, %	ASTM D 4632	20-100	20-100
Trapezoidal Tear, N	ASTM D 4533	156 N (35 lbs.) minimum	334 N (75 lbs.) minimum

6200.7. Packaging. Provide fabric in the length and width specified on the plans, specified in the purchase order awarded by the State or as approved.

Wind fabric onto suitable cylindrical forms or cores to aid in handling and unrolling.

Package fabric individually in a suitable container to protect the geotextile from damage due to ultraviolet light and moisture during normal storage and handling.

6200.8. Identification. Identify each roll with a tag or label affixed to the outside of the roll on one end. List the following information on the tag or label:

- Unique roll number, serially designated;
- Lot number or control numbers, if any;
- Name of fabric producer;
- Style or catalog designation of the fabric, if any;
- Roll width in meters (inches); and
- Roll length in meters (yards).

6200.9. Archived Versions. Archived versions are available.



Material and Performance Specification Sheet

North American Green
 14649 Highway 41 North
 Evansville, IN 47725
 800-772-2040
 FAX: 812-867-0247
www.nagreen.com

A **tensar** Company

S75 Erosion Control Blanket

The short-term single net erosion control blanket shall be a machine-produced mat of 100% agricultural straw with a functional longevity of up to 12 months. (NOTE: functional longevity may vary depending upon climatic conditions, soil, geographical location, and elevation). The blanket shall be of consistent thickness with the straw evenly distributed over the entire area of the mat. The blanket shall be covered on the top side with a lightweight photodegradable polypropylene netting having an approximate 0.50 x 0.50 (1.27 x 1.27 cm) mesh. The blanket shall be sewn together on 1.50 inch (3.81 cm) centers with degradable thread.

The S75 shall meet requirements established by the Erosion Control Technology Council (ECTC) Specification and the US Department of Transportation, Federal Highway Administration's (FHWA) *Standard Specifications for Construction of Roads and Bridges on Federal Highway Projects, FP-03 Section 713.17* as a type 2.C Short-term Single Net Erosion Control Blanket.

The blanket shall be manufactured with a colored thread stitched along both outer edges (approximately 2-5 inches [5-12.5 cm] from the edge) as an overlap guide for adjacent mats.

Material Content		
Matrix	100% Straw Fiber	0.5 lbs/yd ² (0.27 kg/m ²)
Nettings	Top side only, lightweight photodegradable	1.5 lb/1000 ft ² (0.73 kg/100 m ²) approx. weight
Thread	degradable	

S75 is available in the following standard roll sizes:

Width	4.0 ft (1.2 m)	6.67 ft (2.03 m)	16 ft (4.87 m)
Length	135 ft (41.14 m)	108 ft (32.92 m)	108 ft (32.92 m)
Weight ± 10%	30 lbs (13.6 kg)	40 lbs (18.14 kg)	96 lbs (43.54 kg)
Area	60 yd ² (50.16 m ²)	80.0 yd ² (66.9 m ²)	192 yd ² (165.5 m ²)

Index Value Properties:

Property	Test Method	Typical
Thickness	ASTM D6525	0.37 in (9.4 mm)
Resiliency	ECTC Guidelines	78.8%
Water Absorbency	ASTM D1117	426%
Mass/Unit Area	ASTM 6475	11.97 oz/yd ² (407 g/m ²)
Swell	ECTC Guidelines	15%
Smolder Resistance	ECTC Guidelines	Yes
Stiffness	ASTM D1388	6.31 oz-in
Light Penetration	ECTC Guidelines	7.3%
Tensile Strength – MD	ASTM D6818	130.8 lbs/ft (1.94 kN/m)
Elongation – MD	ASTM D6818	24.4%
Tensile Strength – TD	ASTM D6818	85.2 lbs/ft (1.26 kN/m)
Elongation – TD	ASTM D6818	26.8%

Performance Design Values:

Maximum Permissible Shear Stress	
Unvegetated Shear Stress	1.55 lbs/ft ² (74 Pa)
Unvegetated Velocity	5.00 ft/s (1.52 m/s)

Slope Design Data: C Factors			
	Slope Gradients (S)		
Slope Length (L)	≤ 3:1	3:1 – 2:1	≥ 2:1
≤ 20 ft (6 m)	0.029	NA	NA
20-50 ft	0.11	NA	NA
≥ 50 ft (15.2 m)	0.19	NA	NA

Bench Scale Testing* (NTPEP):

Test Method	Parameters	Results
ECTC Method 2 Rainfall	50 mm (2 in)/hr for 30 min	SLR** = 8.80
	100mm (4 in)/hr for 30 min	SLR** = 8.16
	150 mm (6 in)/hr for 30 min	SLR** = 7.81
ECTC Method 3 Shear Resistance	Shear at 0.50 inch soil loss	1.80 lbs/ft²
ECTC Method 4 Germination	Top Soil, Fescue, 21 day incubation	228% improvement of biomass

* Bench Scale tests should not be used for design purposes
 ** Soil Loss Ratio = Soil loss with Bare Soil/Soil Loss with RECP (soil loss is based on regression analysis)

Roughness Coefficients- Unveg.	
Flow Depth	Manning's n
≤ 0.50 ft (0.15 m)	0.055
0.50 – 2.0 ft	0.055 – 0.021
≥ 2.0 ft (0.60 m)	0.021

Product Participant of:



Contech Engineered Solutions Calculations for Texas Commission on Environmental Quality
TSS Removal Calculations

Project Name: **Comal Iron & Metals Recycling**
Date Prepared: **3/23/2023**

1. The Required Load Reduction for the total project:

Calculations from RG-348 Page 3-29 Equation 3.3: $L_M = 27.2(A_N \times P)$
Pages 3-27 to 3-30

$L_{M\ TOTAL\ PROJECT}$ = Required TSS removal resulting from the proposed development = 80% of increased load
 A_N = Net increase in impervious area for the project
P = Average annual precipitation, inches

Site Data: Determine Required Load Removal Based on the Entire Project

County = **Comal**
Total project area included in plan * = **4.30** acres
Predevelopment impervious area within the limits of the plan * = **0.00** acres
Total post-development impervious area within the limits of the plan* = **3.01** acres
Total post-development impervious cover fraction * = **0.70**
P = **33** inches
 $L_{M\ TOTAL\ PROJECT}$ = **2702** lbs.

Number of drainage basins / outfalls areas leaving the plan area = **1**

2. Drainage Basin Parameters (This information should be provided for each basin):

Drainage Basin/Outfall Area No. = **1**
Total drainage basin/outfall area = **4.30** acres
Predevelopment impervious area within drainage basin/outfall area = **0.00** acres
Post-development impervious area within drainage basin/outfall area = **3.01** acres
Post-development impervious fraction within drainage basin/outfall area = **0.70**
 $L_{M\ THIS\ BASIN}$ = **2702** lbs.

3. Indicate the proposed BMP Code for this basin.

Proposed BMP = **JF** abbreviation
Removal efficiency = **86** percent

4. Calculate Maximum TSS Load Removed (L_R) for this Drainage Basin by the selected BMP Type.

RG-348 Page 3-33 Equation 3.7:
 $L_R = (BMP\ efficiency) \times P \times (A_I \times 34.6 + A_P \times 0.54)$

A_C = Total On-Site drainage area in the BMP catchment area
 A_I = Impervious area proposed in the BMP catchment area
 A_P = Pervious area remaining in the BMP catchment area
 L_R = TSS Load removed from this catchment area by the proposed BMP

A_C = **4.30** acres
 A_I = **3.01** acres
 A_P = **1.29** acres
 L_R = **2975** lbs.

5. Calculate Fraction of Annual Runoff to Treat the drainage basin / outfall area

Desired $L_{M\ THIS\ BASIN}$ = **2702** lbs.
F = **0.91**

6. Calculate Treated Flow required by the BMP Type for this drainage basin / outfall area.

Offsite area draining to BMP = **0.00** acres
Offsite impervious cover draining to BMP = **0.00** acres
Rainfall Intensity = **1.15** inches per hour
Effective Area = **2.75** acres
Cartridge Length = **54** inches

Peak Treatment Flow Required = **3.19** cubic feet per second

Calculations from RG-348
Pages Section 3.2.22

7. Jellyfish
Designed as Required in RG-348
Section 3.2.22

Flow Through Jellyfish Size	Vault
Jellyfish Size for Flow-Based Configuration =	JFPD0811-16-4
Jellyfish Treatment Flow Rate =	3.21 cfs

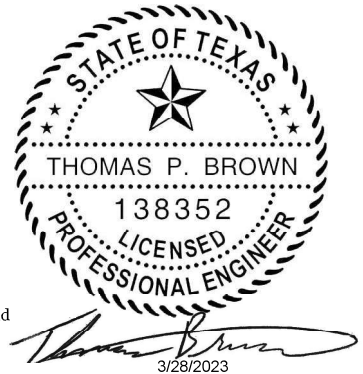

I:\MERLIN\PROJECTS\ACTIVE\747600\747676\747676-10-JELLYFISHDRAWINGS\PROPOSAL\747676-10-JFPD0811-PRO.DWG 7/11/2023 2:16 PM

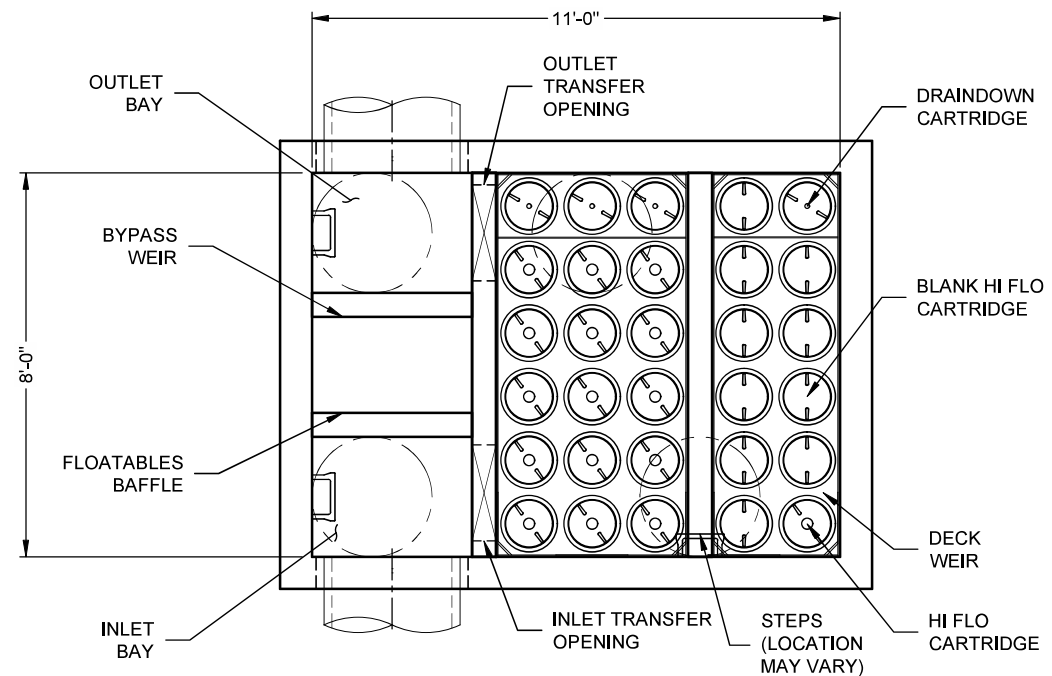

PLAN VIEW
(TOP SLAB NOT SHOWN FOR CLARITY)

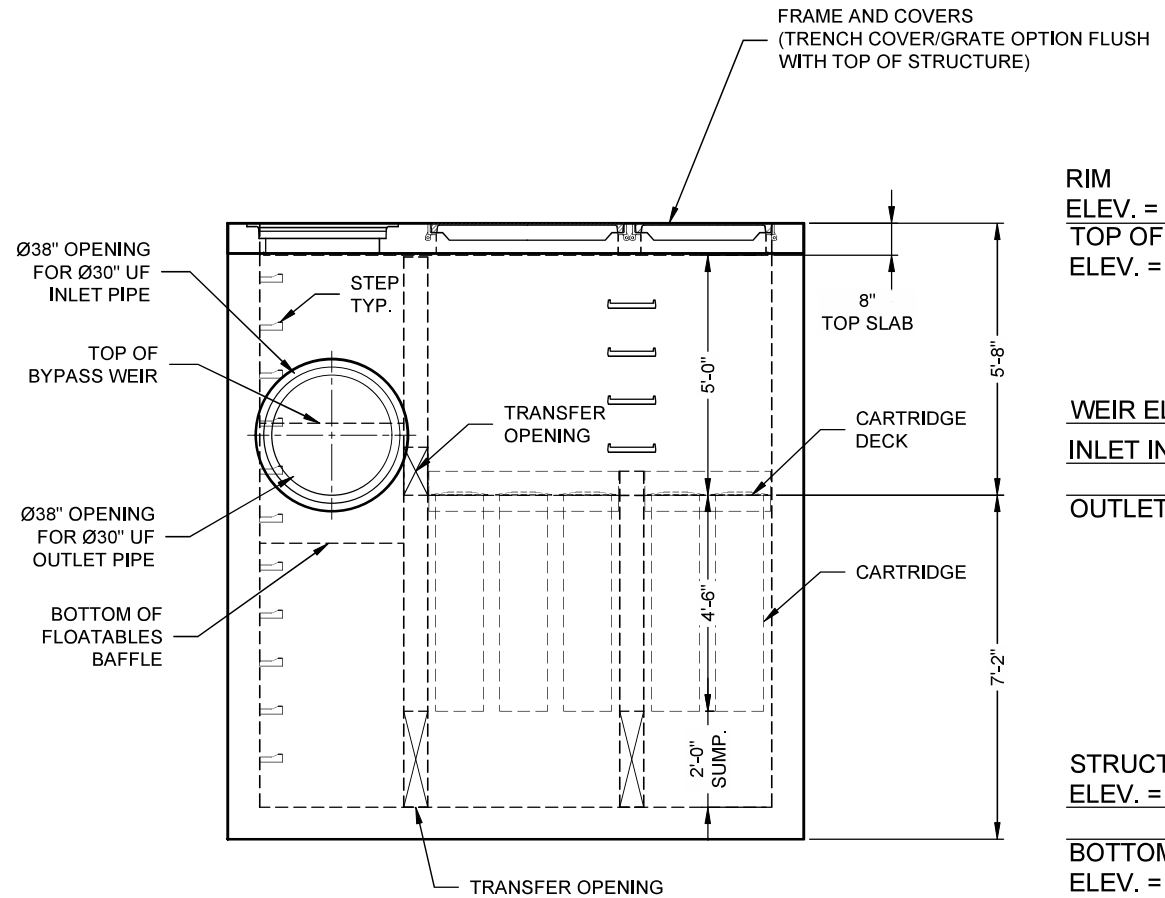

ELEVATION VIEW



JELLYFISH DESIGN NOTES

JELLYFISH TREATMENT CAPACITY IS A FUNCTION OF THE CARTRIDGE LENGTH AND THE NUMBER OF CARTRIDGES. THE STANDARD PEAK DIVERSION STYLE WITH PRECAST TOP SLAB IS SHOWN. ALTERNATE OFFLINE VAULT AND/OR SHALLOW ORIENTATIONS ARE AVAILABLE. PEAK CONVEYANCE CAPACITY TO BE DETERMINED BY ENGINEER OF RECORD

CARTRIDGE SELECTION	
CARTRIDGE LENGTH	54"
OUTLET INVERT TO STRUCTURE INVERT (A)	6'-6"
FLOW RATE HIGH-FLO / DRINDOWN (CFS) (PER CART)	0.178 / 0.089
MAX. TREATMENT (CFS)	4.90
DECK TO INSIDE TOP (MIN) (B)	5.00

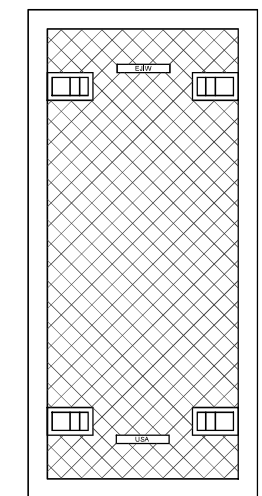
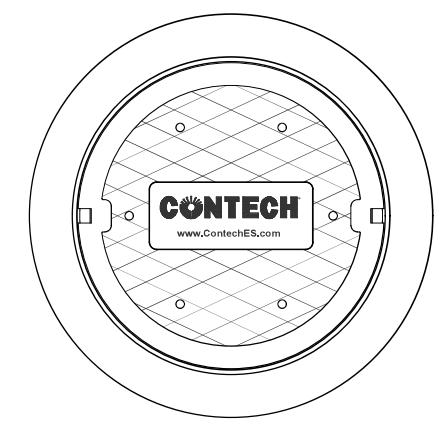

FRAME AND COVER
(DIAMETER VARIES)
N.T.S.

24" TRENCH COVER
(LENGTH VARIES)
N.T.S.

SITE SPECIFIC DATA REQUIREMENTS	
STRUCTURE ID	JELLYFISH
WATER QUALITY FLOW RATE (cfs)	3.19
PEAK FLOW RATE (cfs)	*
RETURN PERIOD OF PEAK FLOW (yrs)	*
# OF CARTRIDGES REQUIRED (HF / DD)	16/4
CARTRIDGE LENGTH	54
PIPE DATA:	I.E. MAT'L DIA SLOPE % HGL
INLET #1	665.50 UF 30" * *
INLET #2	* * * * *
OUTLET	665.00 UF 30" * *
SEE GENERAL NOTES 6-7 FOR INLET AND OUTLET HYDRAULIC AND SIZING REQUIREMENTS.	
RIM ELEVATION	670.67
ANTI-FLOTATION BALLAST	WIDTH HEIGHT
	* *
NOTES/SPECIAL REQUIREMENTS:	
* PER ENGINEER OF RECORD	

RIM
ELEV. = 670.67'
TOP OF STRUCTURE
ELEV. = 670.67'

WEIR ELEV. = 666.50'

INLET INV. ELEV. = 665.50'

OUTLET INV. ELEV. = 665.00'

STRUCTURE INV.
ELEV. = 658.50'

BOTTOM OF STRUCTURE
ELEV. = 657.83'

- GENERAL NOTES:**
- CONTECH TO PROVIDE ALL MATERIALS UNLESS NOTED OTHERWISE.
 - FOR SITE SPECIFIC DRAWINGS WITH DETAILED STRUCTURE DIMENSIONS AND WEIGHT, PLEASE CONTACT YOUR CONTECH ENGINEERED SOLUTIONS REPRESENTATIVE. www.ContechES.com
 - JELLYFISH WATER QUALITY STRUCTURE SHALL BE IN ACCORDANCE WITH ALL DESIGN DATA AND INFORMATION CONTAINED IN THIS DRAWING. CONTRACTOR TO CONFIRM STRUCTURE MEETS REQUIREMENTS OF PROJECT.
 - STRUCTURE SHALL MEET AASHTO HS-20 OR PER APPROVING JURISDICTION REQUIREMENTS, WHICHEVER IS MORE STRINGENT, ASSUMING EARTH COVER OF 0' - 10', AND GROUNDWATER ELEVATION AT, OR BELOW, THE OUTLET PIPE INVERT ELEVATION. ENGINEER OF RECORD TO CONFIRM ACTUAL GROUNDWATER ELEVATION. CASTINGS SHALL MEET AASHTO M306 LOAD RATING AND BE CAST WITH THE CONTECH LOGO.
 - STRUCTURE SHALL BE PRECAST CONCRETE CONFORMING TO ASTM C-857, ASTM C-918, AND AASHTO LOAD FACTOR DESIGN METHOD.
 - OUTLET PIPE INVERT IS EQUAL TO THE CARTRIDGE DECK ELEVATION.
 - THE OUTLET PIPE DIAMETER FOR NEW INSTALLATIONS IS RECOMMENDED TO BE ONE PIPE SIZE LARGER THAN THE INLET PIPE AT EQUAL OR GREATER SLOPE.
 - NO PRODUCT SUBSTITUTIONS SHALL BE ACCEPTED UNLESS SUBMITTED 10 DAYS PRIOR TO PROJECT BID DATE, OR AS DIRECTED BY THE ENGINEER OF RECORD.
- INSTALLATION NOTES**
- ANY SUB-BASE, BACKFILL DEPTH, AND/OR ANTI-FLOTATION PROVISIONS ARE SITE-SPECIFIC DESIGN CONSIDERATIONS AND SHALL BE SPECIFIED BY ENGINEER OF RECORD.
 - CONTRACTOR TO PROVIDE EQUIPMENT WITH SUFFICIENT LIFTING AND REACH CAPACITY TO LIFT AND SET THE STRUCTURE.
 - CONTRACTOR WILL INSTALL AND LEVEL THE STRUCTURE, SEALING THE JOINTS, LINE ENTRY AND EXIT POINTS (NON-SHRINK GROUT WITH APPROVED WATERSTOP OR FLEXIBLE BOOT).
 - CARTRIDGE INSTALLATION, BY CONTECH, SHALL OCCUR ONLY AFTER SITE HAS BEEN STABILIZED AND THE JELLYFISH UNIT IS CLEAN AND FREE OF DEBRIS. CONTACT CONTECH TO COORDINATE CARTRIDGE INSTALLATION WITH SITE STABILIZATION.



CONTECH
ENGINEERED SOLUTIONS LLC
www.ContechES.com
9100 Centre Pointe Dr., Suite 400, West Chester, OH 45069
800-338-1122 513-645-7000 513-645-7993 FAX

8' x 11' JELLYFISH - 747676 - 010
COMAL IRON & METAL RECYCLING
COMAL, TX
SITE DESIGNATION: JELLYFISH SYSTEM

V7511 Trench Cover

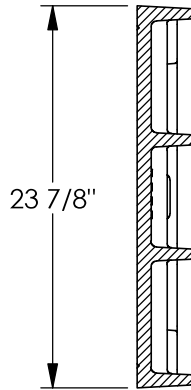
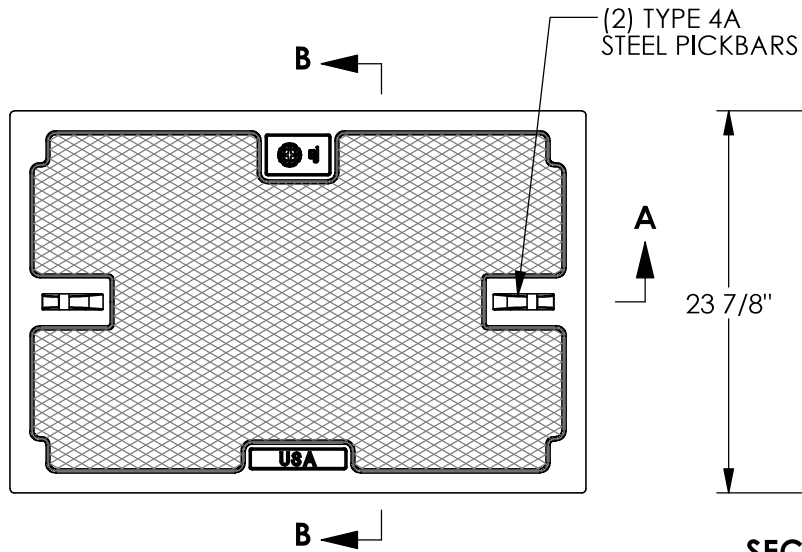

SECTION B-B

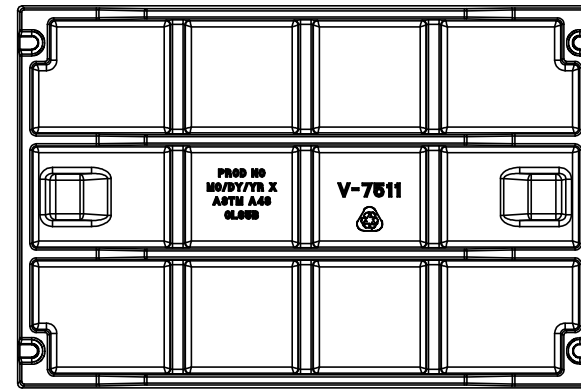

BOTTOM VIEW

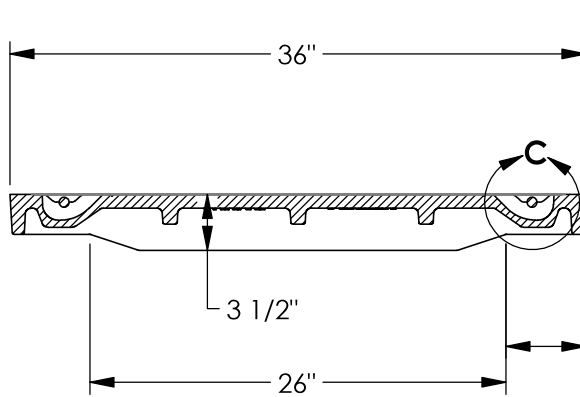

SECTION A-A

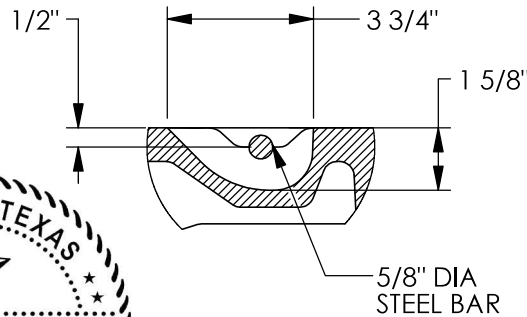
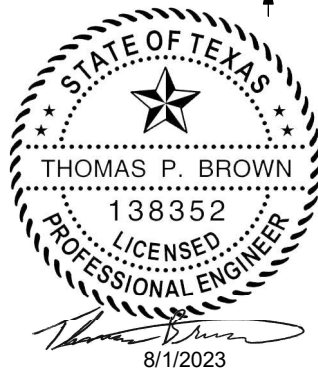

DETAIL C
SCALE 1 : 5

Product Number

47511031

Design Features

- Materials
Gray Iron (CL35B)
- Design Load
Heavy Duty
- Open Area
n/a
- Coating
Undipped
- √ Designates Machined Surface

Certification

- ASTM A48
-
-
- Country of Origin: USA

Drawing Revision

- 10/05/2017 Designer: DJH
- 11/28/2017 Revised By: DJH

Disclaimer

Weights (lbs/kg), dimensions (inches/mm) and drawings provided for your guidance. We reserve the right to modify specifications without prior notice.

CONFIDENTIAL: This drawing is the property of EJ Group, Inc. and embodies confidential information, registered marks, patents, trade secret information, and/or know how that is the property of EJ Group, Inc. Copyright © 2017 EJ Group, Inc. All rights reserved.

Contact

800 626 4653
ejco.com

V7300-3 Trench Rail

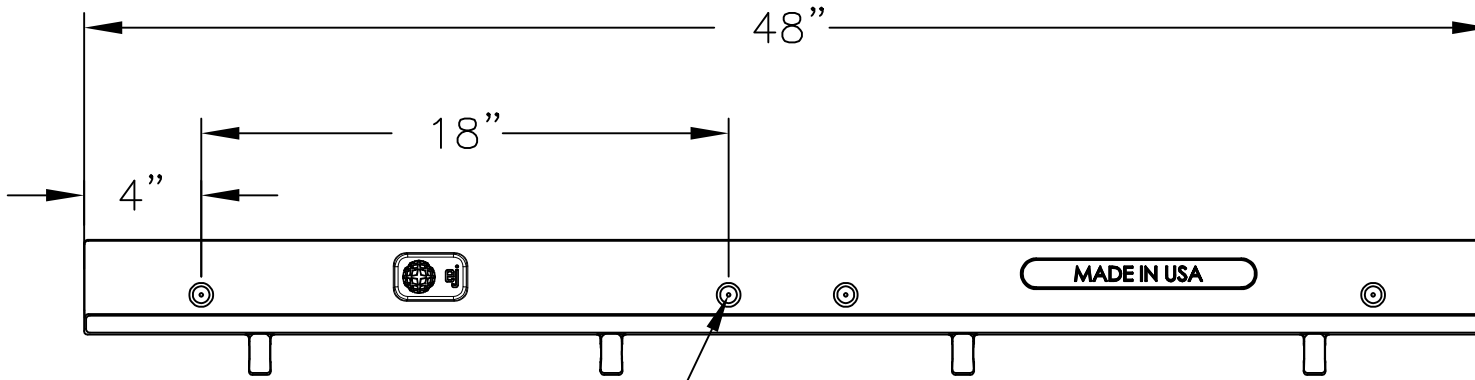

Product Number

47300311

Design Features

- Materials
Gray Iron (CL35B)
- Design Load
Heavy Duty
- Open Area
n/a
- Coating
Undipped
- √ Designates Machined Surface

1/8" DIA. THRU HOLE FOR FORMING NAILS

FRONT VIEW



Certification

- ASTM A536
-
- Country of Origin: USA

Estimated Weight:

- 38 lbs

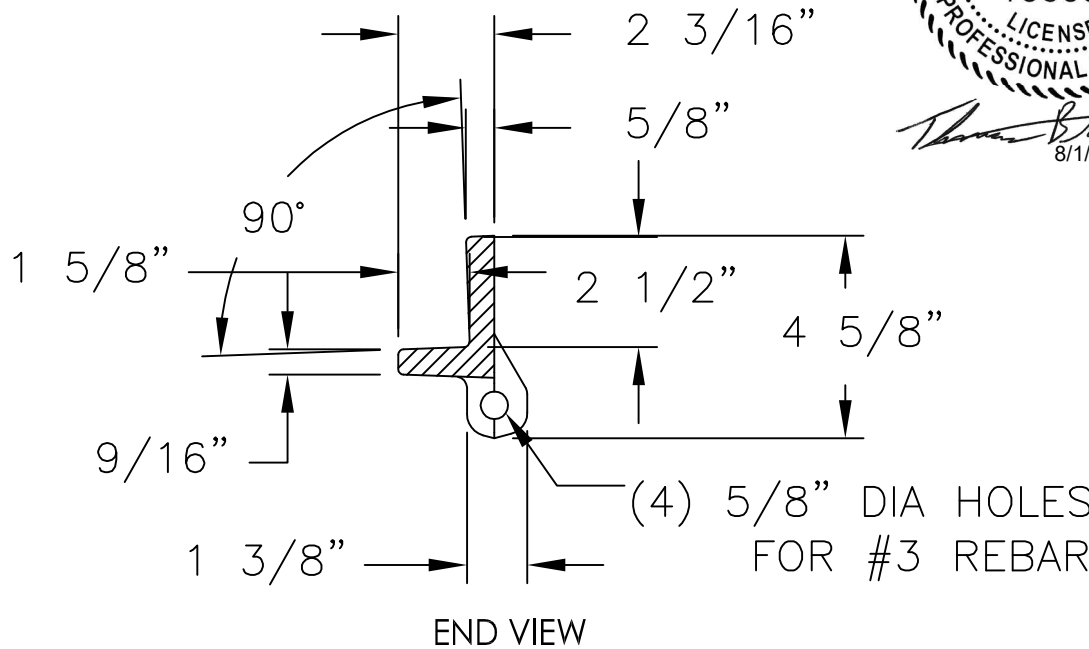

END VIEW

Drawing Revision

- 4/16/2005 Designer: SBB
- 4/18/2018 Revised By: DAE

Disclaimer

Weights (lbs./kg) dimensions (inches/mm) and drawings provided for your guidance. We reserve the right to modify specifications without prior notice.

CONFIDENTIAL: This drawing is the property of EJ GROUP, Inc., and embodies confidential information, registered marks, patents, trade secret information, and/or know how that is the property of EJ GROUP, Inc. Copyright © 2012 EJ GROUP, Inc. All rights reserved.

Contact

800 626 4653
ejco.com

1810B4 V1600-4 Assembly

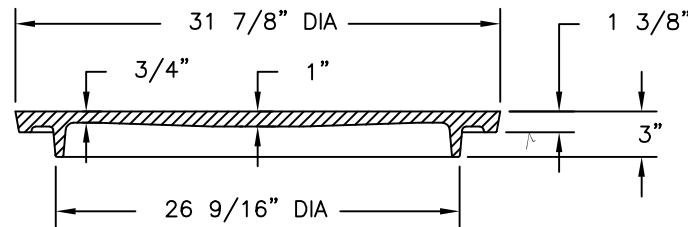
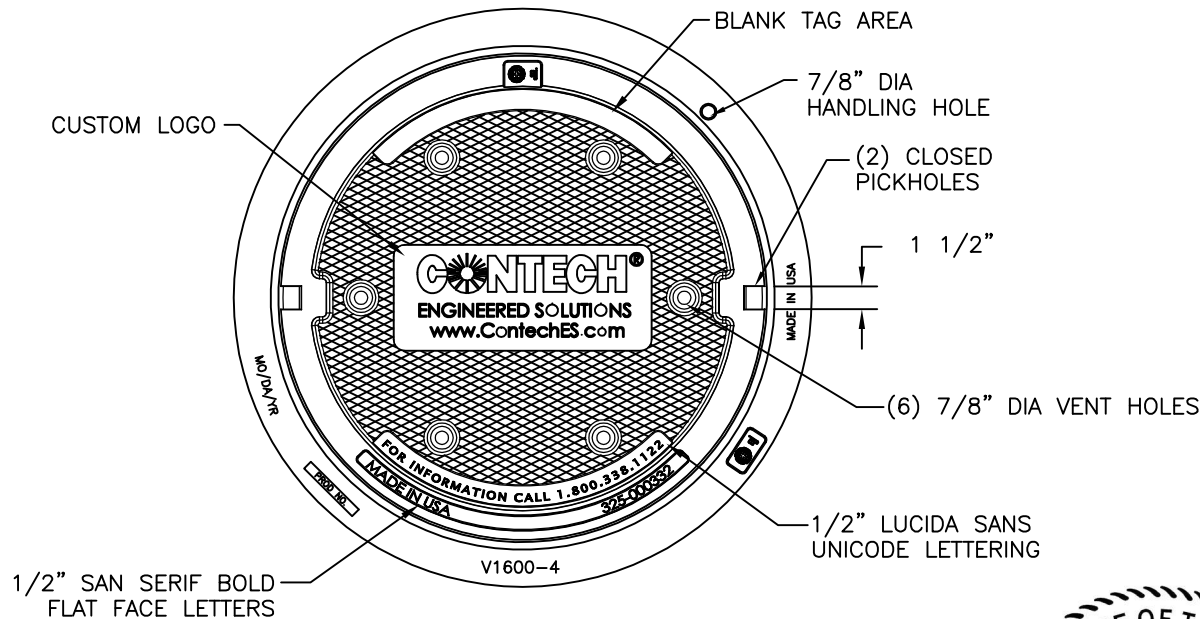

COVER SECTION

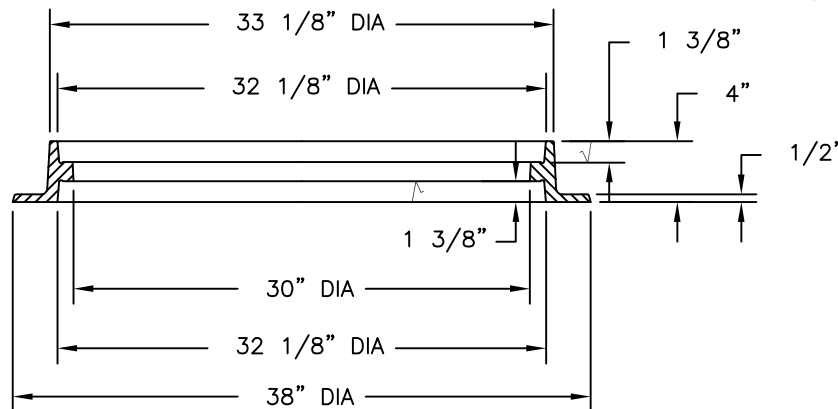

FRAME SECTION



Product Number
41600483

Design Features

- Materials
 - Cover Gray Iron (CL35B)
 - Frame Gray Iron (CL35B)

- Design Load Heavy Duty
- Open Area n/a
- Coating Undipped
- √ Designates Machined Surface

Certification

- ASTM A48
- Country of Origin: USA

Major Components

- 00180783
- 41600410

Drawing Revision

- 05/09/2007 Designer: SMH
- 6/26/2017 Revised By: DAE

Disclaimer

Weights (lbs./kg) dimensions (inches/mm) and drawings provided for your guidance. We reserve the right to modify specifications without prior notice.

CONFIDENTIAL: This drawing is the property of EJ GROUP, Inc., and embodies confidential information, registered marks, patents, trade secret information, and/or know how that is the property of EJ GROUP, Inc. Copyright © 2012 EJ GROUP, Inc. All rights reserved.

Contact

800 626 4653
ejco.com



Section 6: Comal Iron and Metals – Permanent Stormwater Section
(TCEQ - 0600)

ATTACHMENT D

Comal Iron and Metals – BMPs for Surface Streams

This attachment does not apply to this submittal. There are no surface streams at the project site.



Section 6: Comal Iron and Metals – Permanent Stormwater Section
(TCEQ - 0600)

ATTACHMENT E

Comal Iron and Metals – Request to Seal Features

This attachment does not apply to this submittal. No requests to seal features are proposed at this time.



Section 6: Comal Iron and Metals – Permanent Stormwater Section
(TCEQ - 0600)

ATTACHMENT F

Comal Iron and Metals – Construction Plans

Construction plans for the Contech Jellyfish Filter are provided.

CONSTRUCTION DOCUMENTS

FOR THE

STORM WATER RUN-OFF MODIFICATIONS

FOR

COMAL IRON AND METALS

1431 FM306

NEW BRAUNFELS, TEXAS 78132

INDEX OF DRAWINGS

SHEET #	SHEET DESCRIPTION
G-0.0	COVER SHEET
G-1.0	GENERAL NOTES
C-1.0	EXISTING CONDITIONS
C-1.1	EXISTING SOUTHEAST DRAINAGE SWALE PLAN-PROFILE
C-1.2	EXISTING SOUTHWEST DRAINAGE SWALE PLAN-PROFILE
C-2.0	PROPOSED BMP SYSTEM IMPROVEMENTS
C-2.1	PROPOSED BMP SYSTEM SITE LAYOUT
C-2.2	RECONSTRUCTED SOUTHEAST SWALE PLAN - PROFILE
C-2.3	PROPOSED BMP SYSTEM SITE REGRADING PLAN
C-2.4	PROPOSED SITE REGRADING CROSS SECTIONS
D-1.0	JELLYFISH JFPD0811 DETAILS
D-2.0	GENERAL DETAILS

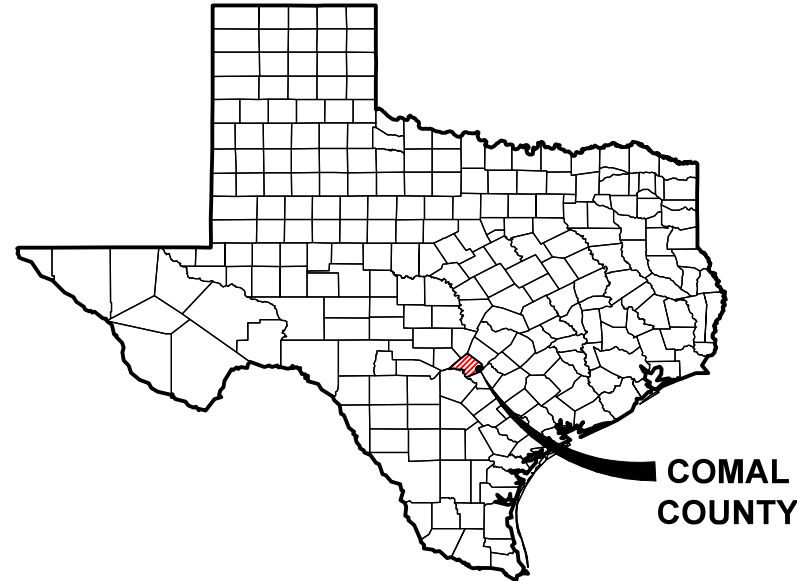

TEXAS LOCATION MAP

NTS

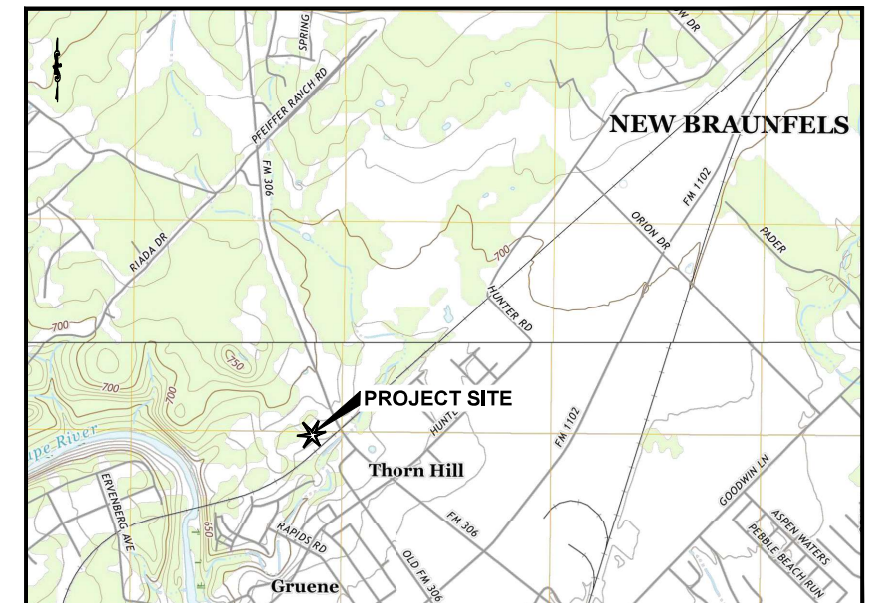

SOURCE: U.S.G.S. 7.5 Minute Topo Quad of: New Braunfels West, New Braunfels East TX. 2022.

AREA TOPOGRAPHICAL MAP

SCALE: 1" = 3000'

PROJECT INFORMATION

PROJECT LOCATION	1431 FM306 NEW BRAUNFELS, TEXAS 78132
CLIENT CONTACT	ADRIANA LEE- JAMES ENVIRONMENTAL MANAGEMENT, INC.
DESIGN CONTACT	ENSAFE INC. 1603 LYNDON B JOHNSON FWY SUITE 700 FARMERS BRANCH, TX 75234 972-791-3222

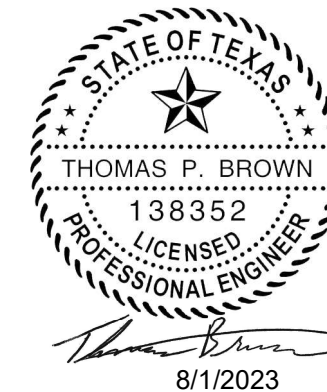

PREPARED BY:



Creative thinking.
Custom solutions.

engineering | environment | health & safety | technology

Telephone (800)588-7962 | www.ensafe.com

a global professional services company



SHEET NUMBER

G-0.0

REVISIONS

NO.	DATE	DESCRIPTION

PROJECT #0888835569
DATE: JULY 31, 2023

TCEQ EDWARDS AQUIFER PROTECTION CONSTRUCTION NOTES

San Antonio Regional Office
14250 Judson Road
San Antonio, Texas 78233-4480
Phone (210) 490-3096
Fax (210) 545-4329

Texas Commission on Environmental Quality
Water Pollution Abatement Plan
General Construction Notes

Austin Regional Office
12100 Park 35 Circle, Building A
Austin, Texas 78753-1808
Phone (512) 339-2929
Fax (512) 339-3795

Edwards Aquifer Protection Program Construction Notes – Legal Disclaimer

The following listed "construction notes" are intended to be advisory in nature only and do not constitute an approval or conditional approval by the Executive Director (ED), nor do they constitute a comprehensive listing of rules or conditions to be followed during construction. Further actions may be required to achieve compliance with TCEQ regulations found in Title 30, Texas Administrative Code (TAC), Chapters 213 and 217, as well as local ordinances and regulations providing for the protection of water quality. Additionally, nothing contained in the following listed "construction notes" restricts the powers of the ED, the commission or any other governmental entity to prevent, correct, or curtail activities that result or may result in pollution of the Edwards Aquifer or hydrologically connected surface waters. The holder of any Edwards Aquifer Protection Plan containing "construction notes" is still responsible for compliance with Title 30, TAC, Chapters 213 or any other applicable TCEQ regulation, as well as all conditions of an Edwards Aquifer Protection Plan through all phases of plan implementation. Failure to comply with any condition of the ED's approval, whether or not in contradiction of any "construction notes," is a violation of TCEQ regulations and any violation is subject to administrative rules, orders, and penalties as provided under Title 30, TAC § 213.10 (relating to Enforcement). Such violations may also be subject to civil penalties and injunction. The following listed "construction notes" in no way represent an approved exception by the ED to any part of Title 30 TAC, Chapters 213 and 217, or any other TCEQ applicable regulation

1. A written notice of construction must be submitted to the TCEQ regional office at least 48 hours prior to the start of any regulated activities. This notice must include:
 - the name of the approved project;
 - the activity start date; and
 - the contact information of the prime contractor.
2. All contractors conducting regulated activities associated with this project must be provided with complete copies of the approved Water Pollution Abatement Plan (WPAP) and the TCEQ letter indicating the specific conditions of its approval. During the course of these regulated activities, the contractors are required to keep on-site copies of the approved plan and approval letter.
3. If any sensitive feature(s) (caves, solution cavity, sink hole, etc.) is discovered during construction, all regulated activities near the sensitive feature must be suspended immediately. The appropriate TCEQ regional office must be immediately notified of any sensitive features encountered during construction. Construction activities may not be resumed until the TCEQ has reviewed and approved the appropriate protective measures in order to protect any sensitive feature and the Edwards Aquifer from potentially adverse impacts to water quality.
4. No temporary or permanent hazardous substance storage tank shall be installed within 150 feet of a water supply source, distribution system, well, or sensitive feature.
5. Prior to beginning any construction activity, all temporary erosion and sedimentation (E&S) control measures must be properly installed and maintained in accordance with the approved plans and manufacturers specifications. If inspections indicate a control has been used inappropriately, or incorrectly, the applicant must replace or modify the control for site situations. These controls must remain in place until the disturbed areas have been permanently stabilized.
6. Any sediment that escapes the construction site must be collected and properly disposed of before the next rain event to ensure it is not washed into surface streams, sensitive features, etc.
7. Sediment must be removed from the sediment traps or sedimentation basins not later than when it occupies 50% of the basin's design capacity.
8. Litter, construction debris, and construction chemicals exposed to stormwater shall be prevented from being discharged offsite.
9. All spoils (excavated material) generated from the project site must be stored on-site with proper E&S controls. For storage or disposal of spoils at another site on the Edwards Aquifer Recharge Zone, the owner of the site must receive approval of a water pollution abatement plan for the placement of fill material or mass grading prior to the placement of spoils at the other site.
10. If portions of the site will have a temporary or permanent cease in construction activity lasting longer than 14 days, soil stabilization in those areas shall be initiated as soon as possible prior to the 14th day of inactivity. If activity will resume prior to the 21st day, stabilization measures are not required. If drought conditions or inclement weather prevent action by the 14th day, stabilization measures shall be initiated as soon as possible.
11. The following records shall be maintained and made available to the TCEQ upon request:
 - the dates when major grading activities occur;
 - the dates when construction activities temporarily or permanently cease on a portion of the site; and
 - the dates when stabilization measures are initiated.
12. The holder of any approved Edward Aquifer protection plan must notify the appropriate regional office in writing and obtain approval from the executive director prior to initiating any of the following:
 - A. any physical or operational modification of any water pollution abatement structure(s), including but not limited to ponds, dams, berms, sewage treatment plants, and diversionary structures;
 - B. any change in the nature or character of the regulated activity from that which was originally approved or a change which would significantly impact the ability of the plan to prevent pollution of the Edwards Aquifer;
 - C. any development of land previously identified as undeveloped in the original water pollution abatement plan.

EXCAVATION AND DISTURBED AREA NOTES:

1. THE CONTRACTOR SHALL PROVIDE PROTECTIVE MEASURES IN EXISTING AREAS NOT DESIGNATED FOR DEMOLITION OR CONSTRUCTION. THE CONTRACTOR SHALL BE RESPONSIBLE FOR THE REPAIR OF ANY DAMAGE CAUSED BY HIS OR ANY SUBCONTRACTORS' WORK.
2. THE CONTRACTOR SHALL MEET WITH THE OWNER'S CONSTRUCTION MANAGER WELL IN ADVANCE OF CONSTRUCTION COMMENCEMENT TO SCHEDULE, SEQUENCE, AND COORDINATE ALL WORK.
3. THE CONTRACTOR SHALL VERIFY DIMENSIONS OF AS-BUILT CONDITIONS, AND NOTIFY THE ENGINEER IN WRITING OF ANY DISCREPANCIES.
4. THE CONTRACTOR SHALL FIELD SURVEY AND DETERMINE THE ACTUAL LIMITS OF CONSTRUCTION EITHER WHOLE OR IN PART, AS REQUIRED FOR THE PROPOSED CONSTRUCTION.
5. CONTRACTOR TO CALL IN UTILITY LOCATES AND COORDINATE WITH ALL APPLICABLE UTILITY PROVIDERS PRIOR TO CONSTRUCTION.
6. IF ANY EXCAVATED MATERIAL IS FOUND TO BE CONTAMINATED, IT WILL BE MANAGED IN ACCORDANCE WITH APPLICABLE RULES AND REGULATIONS.
7. CLEARING, GRUBBING, AND OTHER DISTURBANCE SHALL BE LIMITED TO THE MINIMUM NECESSARY FOR CONSTRUCTION AND EQUIPMENT OPERATIONS.
8. ALL DISTURBED AREAS SHALL BE PROPERLY STABILIZED AS SOON AS PRACTICABLE.
9. CONSTRUCTION SHALL BE SEQUENCED AND STAGED TO MINIMIZE THE IMPACT OF DISTURBED AREAS AND ASSOCIATED STORM WATER RUN-OFF.
10. EROSION PREVENTION AND SEDIMENT CONTROL (EPSC) MEASURES SHALL BE INSTALLED AND FUNCTIONAL PRIOR TO ANY EARTH MOVING OPERATIONS, AND SHALL BE MAINTAINED THROUGHOUT THE CONSTRUCTION PERIOD. CONTRACTOR SHALL INSTALL TEMPORARY EROSION CONTROL LOG DAMS AS REQUIRED AND AS DIRECTED BY THE OWNER OR ENGINEER DURING CONSTRUCTION.
11. TEMPORARY EPSC MEASURES USED DURING CONSTRUCTION ARE TO BE INSPECTED BY THE CONTRACTOR DAILY. MAINTENANCE AND REPAIR ACTIVITIES ARE THE RESPONSIBILITY OF THE CONTRACTOR.

GENERAL NOTES

1. SUBJECT PROPERTY IS IDENTIFIED AS PROPERTY IDs 30881 AND 150222 OF NEW BRAUNFELS, COMAL COUNTY, TEXAS.
2. THE PROPERTY SHOWN DOES NOT LIE WITHIN THE 100-YEAR FLOOD PLAIN PER FIRM PANEL NUMBER 48091C0455F, DATED SEPTEMBER 02, 2009.
3. EXISTING SURFACE CONTOURS BASED OFF TOPOGRAPHIC SURVEY COMPLETED BY TOTAL GEO DATA SURVEYING, LLC (TX FIRM NO. 10193904) JUNE 14-21, 2023.
4. CONTRACTOR SHALL NOTIFY THE OWNER AT LEAST 48 HOURS PRIOR TO BEGINNING CONSTRUCTION.
5. CONTRACTOR MUST KEEP AVAILABLE ONSITE, AT ALL TIMES, APPROVED CONSTRUCTION PLANS AND COPIES OF ANY REQUIRED PERMITS.
6. CONTRACTOR SHALL BE RESPONSIBLE FOR ALL REQUIRED CONSTRUCTION SURVEYING AND STAKING AND SHALL NOTIFY THE ENGINEER OF ANY DISCREPANCIES PRIOR TO PROCEEDING WITH ANY WORK.
7. CONTRACTOR SHALL BE RESPONSIBLE FOR PROTECTING ALL SURVEY MARKERS INCLUDING IRON RODS, PROPERTY CORNERS, OR SURVEY MONUMENTS WITHIN THE LIMITS OF CONSTRUCTION AND OUTSIDE ROW DURING CONSTRUCTION. ANY SURVEY MARKERS DISTURBED DURING CONSTRUCTION SHALL BE REPLACED BY THE CONTRACTOR AT NO COST TO THE OWNER.
8. UNUSABLE EXCAVATED MATERIAL SHALL BE REMOVED AND DISPOSED OF ONSITE AS DETERMINED BY OWNER. CONSTRUCTION DEBRIS SHALL BE REMOVED AND DISPOSED OF AT AN APPROVED DISPOSAL FACILITY BY CONTRACTOR AT CONTRACTOR'S EXPENSE.
9. THE CONTRACTOR SHALL VERIFY THE EXACT LOCATION OF ALL EXISTING UTILITIES. TAKE CARE TO PROTECT UTILITIES THAT ARE TO REMAIN. REPAIR CONTRACTOR CAUSED DAMAGE ACCORDING TO LOCAL STANDARDS AND AT THE CONTRACTOR'S EXPENSE. COORDINATE ALL CONSTRUCTION WITH THE APPROPRIATE UTILITY COMPANY.
10. THE CONTRACTOR SHALL CONFORM TO ALL LOCAL CODES AND OBTAIN ALL PERMITS PRIOR TO BEGINNING WORK.
11. CONTRACTOR SHALL EXERCISE EXTREME CAUTION IN THE USE OF EQUIPMENT NEAR OVERHEAD AND UNDERGROUND ELECTRICAL WIRES AND SERVICE. IF AT ANY TIME IN THE PURSUIT OF THIS WORK THE CONTRACTOR MUST WORK IN CLOSE PROXIMITY OF THE ABOVE NOTED WIRES, THE ELECTRICAL COMPANY SHALL BE CONTACTED PRIOR TO SUCH WORK AND THE PROPER SAFETY MEASURES TAKEN.
12. CONTRACTOR SHALL EXERCISE EXTREME CAUTION IN THE USE OF EQUIPMENT NEAR AROUND UNDERGROUND GAS LINES.

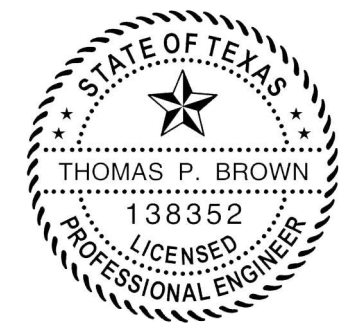

Thomas P. Brown
8/1/2023

GENERAL NOTES

STORM WATER RUN-OFF MODIFICATIONS
FOR
COMAL IRON AND METALS
1431 FM306
NEW BRAUNFELS, TEXAS 78132

REQUESTED BY: TB
DRAWN BY: WM
DATE: 7/31/2023
PROJECT: 0888835569



SHEET NUMBER
G-1.0

© Comal Iron - New Braunfels, TX 2023 Project Desc: Working drawings for project\0401 - Master (Sheet) Sheets\3569 Comal Iron - New Braunfels, TX Comal Desc - 23123 - ITC.dwg

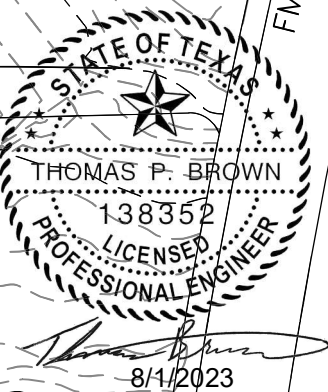
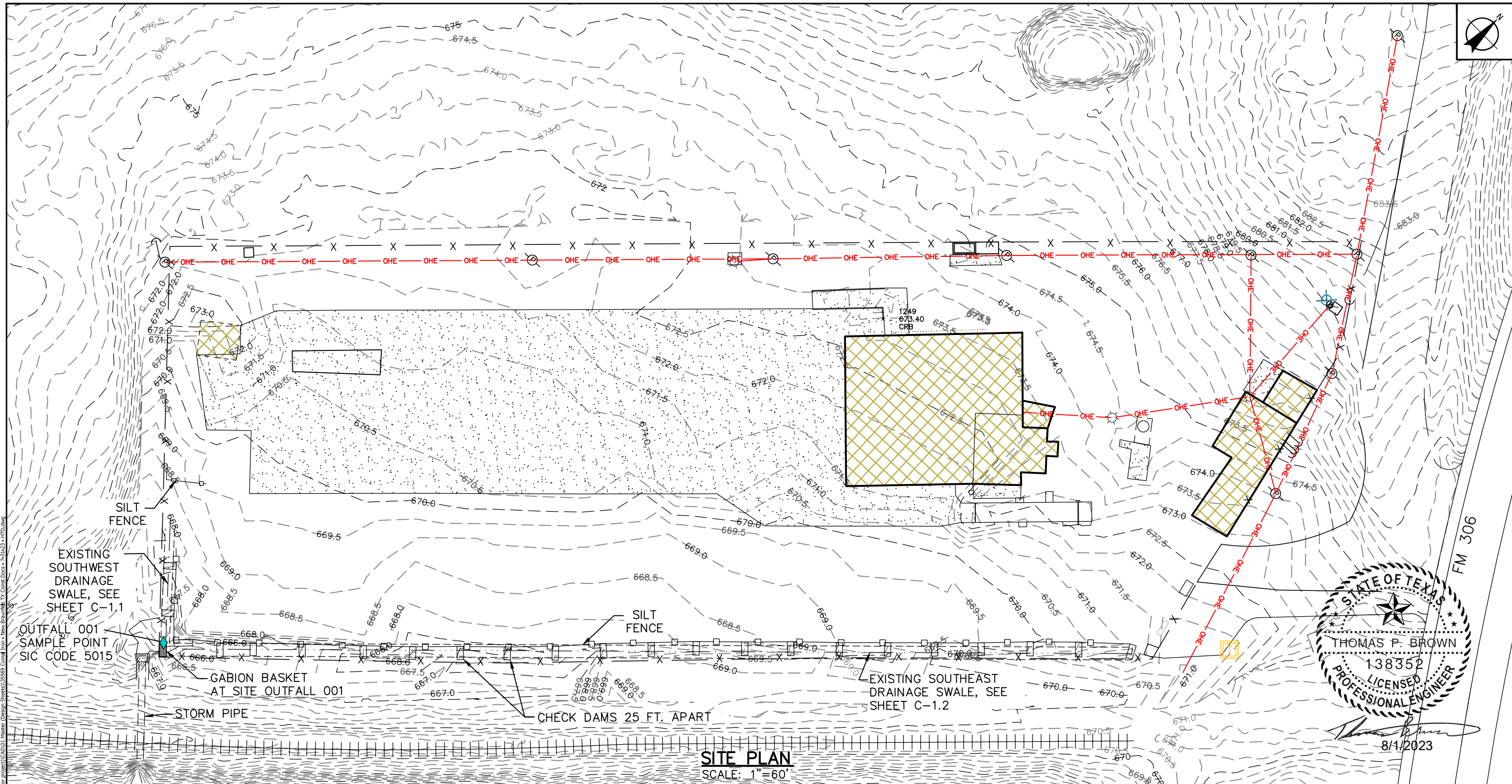

SITE PLAN
SCALE: 1"=60'

LEGEND

- | | | | | | |
|--|--------------------------|--|-----------------------|--|--------------------|
| | EXISTING RAIL ROAD TRACK | | WATER WELL | | POWER POLE |
| | SILT FENCE | | CHECK DAM | | OVERHEAD ELECTRIC |
| | FENCE | | CONCRETE | | TELEPHONE PEDESTAL |
| | OUTFALL | | BUILDING/COVERED AREA | | |
| | CENTERLINE OF SWALE | | | | |

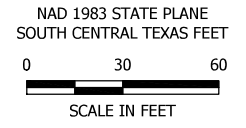

SHEET NUMBER
C-1.0

EXISTING CONDITIONS	
STORM WATER RUN-OFF MODIFICATIONS	
FOR COMAL IRON AND METALS 1431 FM306 NEW BRAUNFELS, TEXAS 78132	
REQUESTED BY:	TB
DRAWN BY:	WM
DATE:	7/31/2023
PROJECT:	0888835569
ENSAFE Creative thinking. Custom solutions. 800.588.7962 www.ensafe.com	

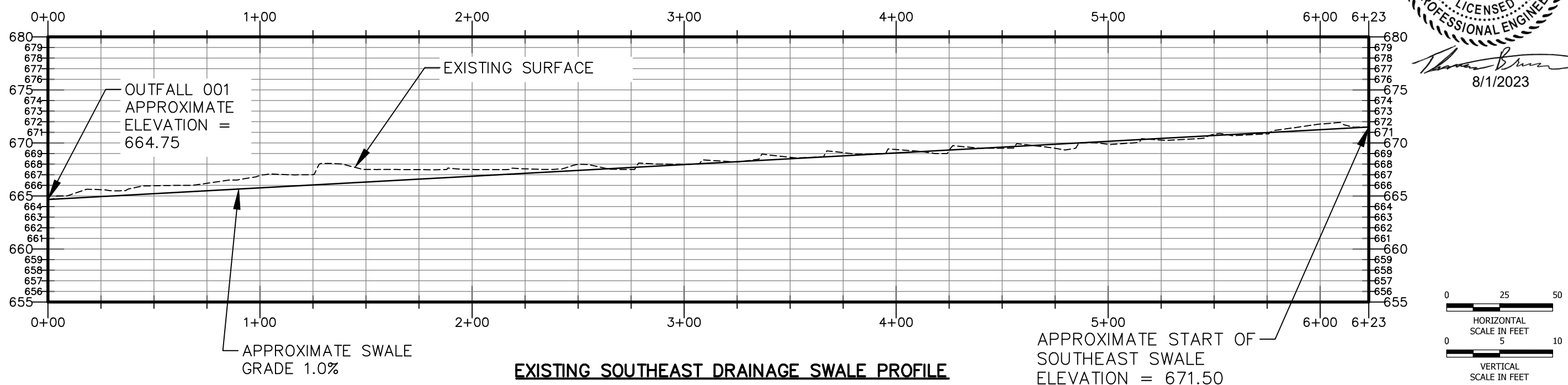
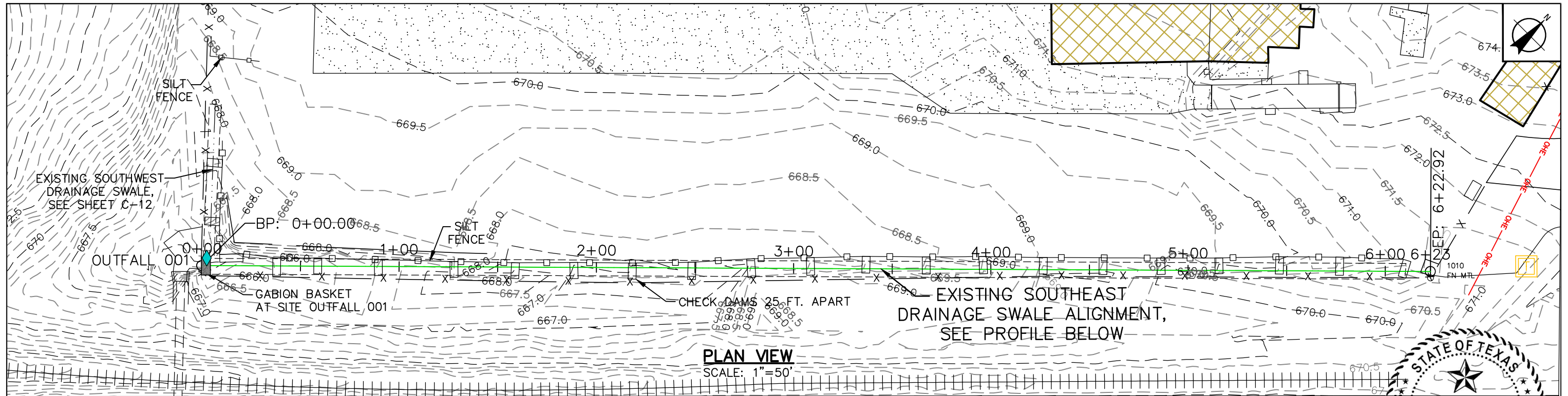

LEGEND

- ||||| EXISTING RAIL ROAD TRACK
- o-o-o-o- SILT FENCE
- x-x-x-x- FENCE
- ◆ OUTFALL 001
- CHECK DAM
- CONCRETE
- BUILDING/COVERED AREA
- ⊙ POWER POLE
- OHE-OHE- OVERHEAD ELECTRIC
- ⌈ TELEPHONE PEDESTAL
- EXISTING SOUTHWEST DRAINAGE SWALE

EXISTING SOUTHWEST DRAINAGE SWALE PLAN-PROFILE

STORM WATER RUN-OFF MODIFICATIONS FOR COMAL IRON AND METALS
1431 FM306
NEW BRAUNFELS, TEXAS 78132

REQUESTED BY:	TB	ENSAFE Creative thinking. Custom solutions. 800.588.7962 www.ensafe.com
DRAWN BY:	WM	
DATE:	7/31/2023	
PROJECT:	0888835569	

SHEET NUMBER
C-1.1

A:\Comal Iron - New Braunfels (Working drawings for project)\CAD\01 Master (Design Sheets)\35569 Comal Iron - New Braunfels TX Cont. Docs - 7-31-23 - HFD.dwg

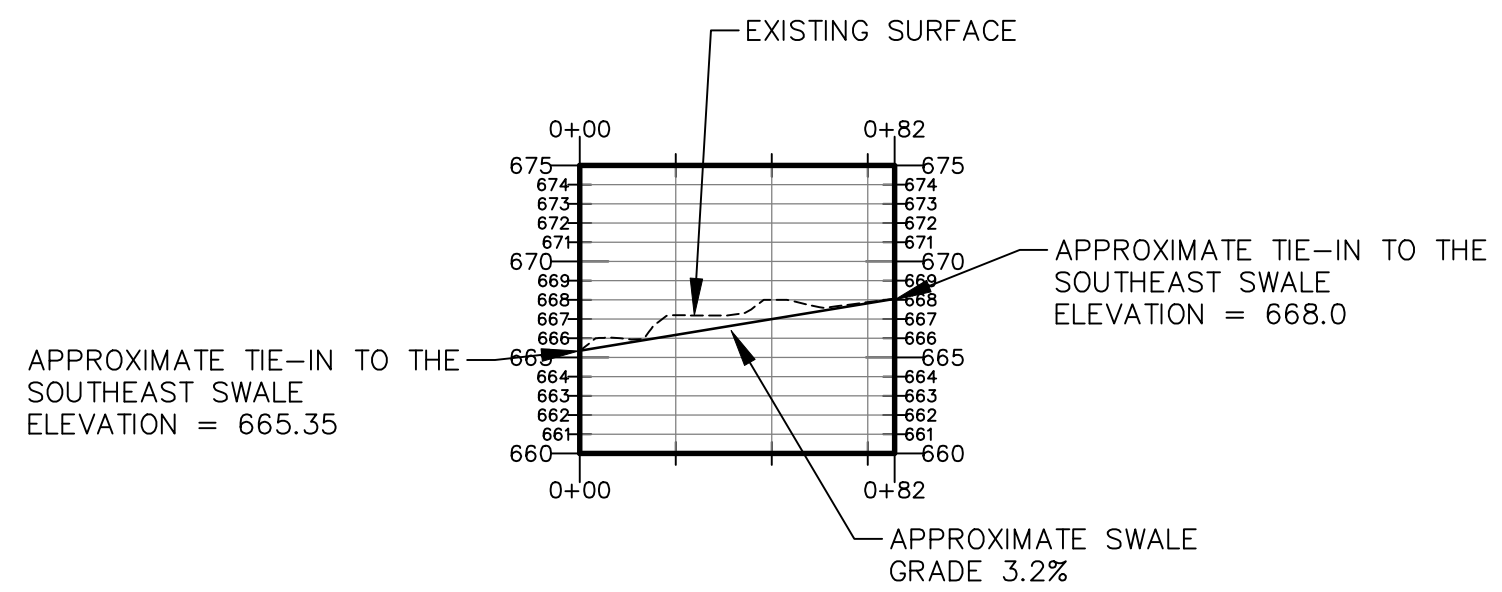
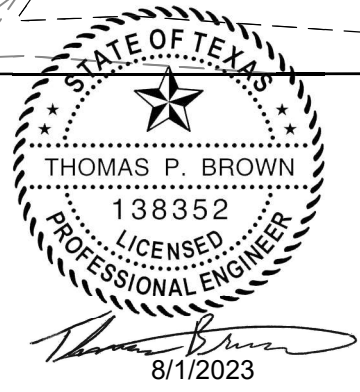
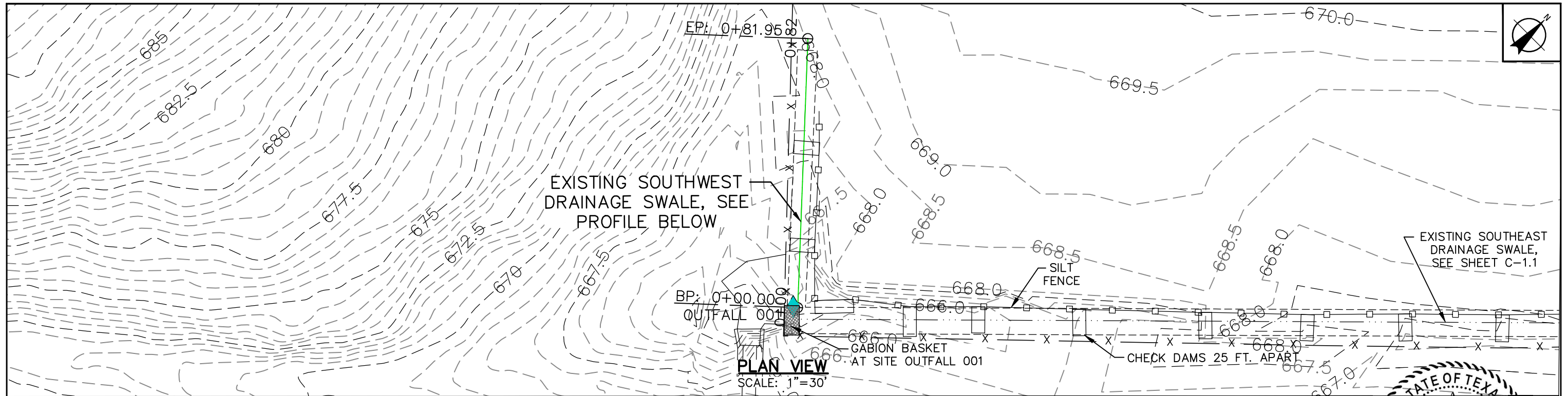

EXISTING SOUTHWEST DRAINAGE SWALE PROFILE

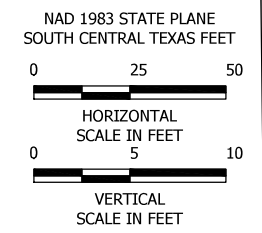

LEGEND

- EXISTING RAIL ROAD TRACK
- SILT FENCE
- FENCE
- OUTFALL 001
- CHECK DAM
- CONCRETE
- POWER POLE
- EXISTING SOUTHWEST DRAINAGE SWALE

EXISTING SOUTHWEST DRAINAGE SWALE PLAN-PROFILE
STORM WATER RUN-OFF MODIFICATIONS
 FOR
COMAL IRON AND METALS
 1431 FM306
 NEW BRAUNFELS, TEXAS 78132

REQUESTED BY:	TB	
DRAWN BY:	WM	
DATE:	7/31/2023	
PROJECT:	0888835569	

SHEET NUMBER
C-1.2

Creative thinking. Custom solutions.
 800.588.7962 | www.ensafe.com

P:\Comal Iron - New Braunfels - Working Drawings for project\CAD\01 Master (Design Sheets)\35569 Comal Iron - New Braunfels TX Civil Docs - 7-31-23 - ITP.dwg



©Comal Iron - New Braunfels, TX 2023 Project Exec (Working drawings for project) CAD01 Master (Design Sheets) 35569 Comal Iron - New Braunfels, TX Comal Docs - 23123 - IITD.dwg

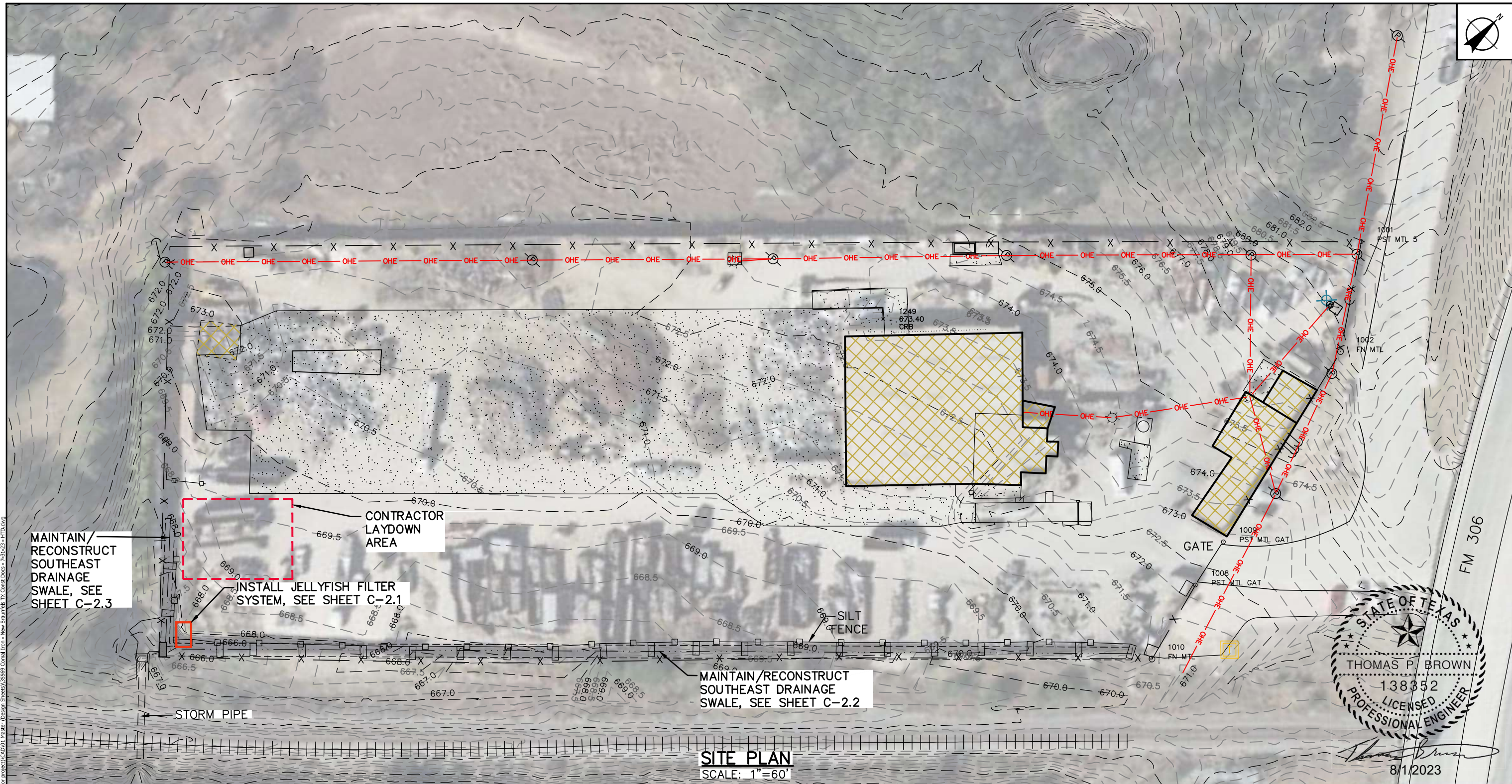

SITE PLAN
SCALE: 1"=60'

STATE OF TEXAS
THOMAS P. BROWN
138352
LICENSED
PROFESSIONAL ENGINEER
Thomas P. Brown
8/1/2023

LEGEND

- EXISTING RAIL ROAD TRACK
- SILT FENCE
- FENCE
- CENTERLINE OF SWALE
- RECONSTRUCTED SOUTHEAST SWALE
- WATER WELL
- CHECK DAM
- CONCRETE
- BUILDING/COVERED AREA
- OVERHEAD ELECTRIC
- POWER POLE
- TELEPHONE PEDESTAL

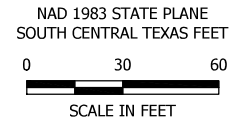

SHEET NUMBER
C-2.0

PROPOSED BMP SYSTEM IMPROVEMENTS

STORM WATER RUN-OFF MODIFICATIONS
FOR
COMAL IRON AND METALS
1431 FM306
NEW BRAUNFELS, TEXAS 78132

REQUESTED BY:	TB	 Creative thinking. Custom solutions. 800.588.7962 www.ensafe.com
DRAWN BY:	WM	
DATE:	7/31/2023	
PROJECT:	0888835569	

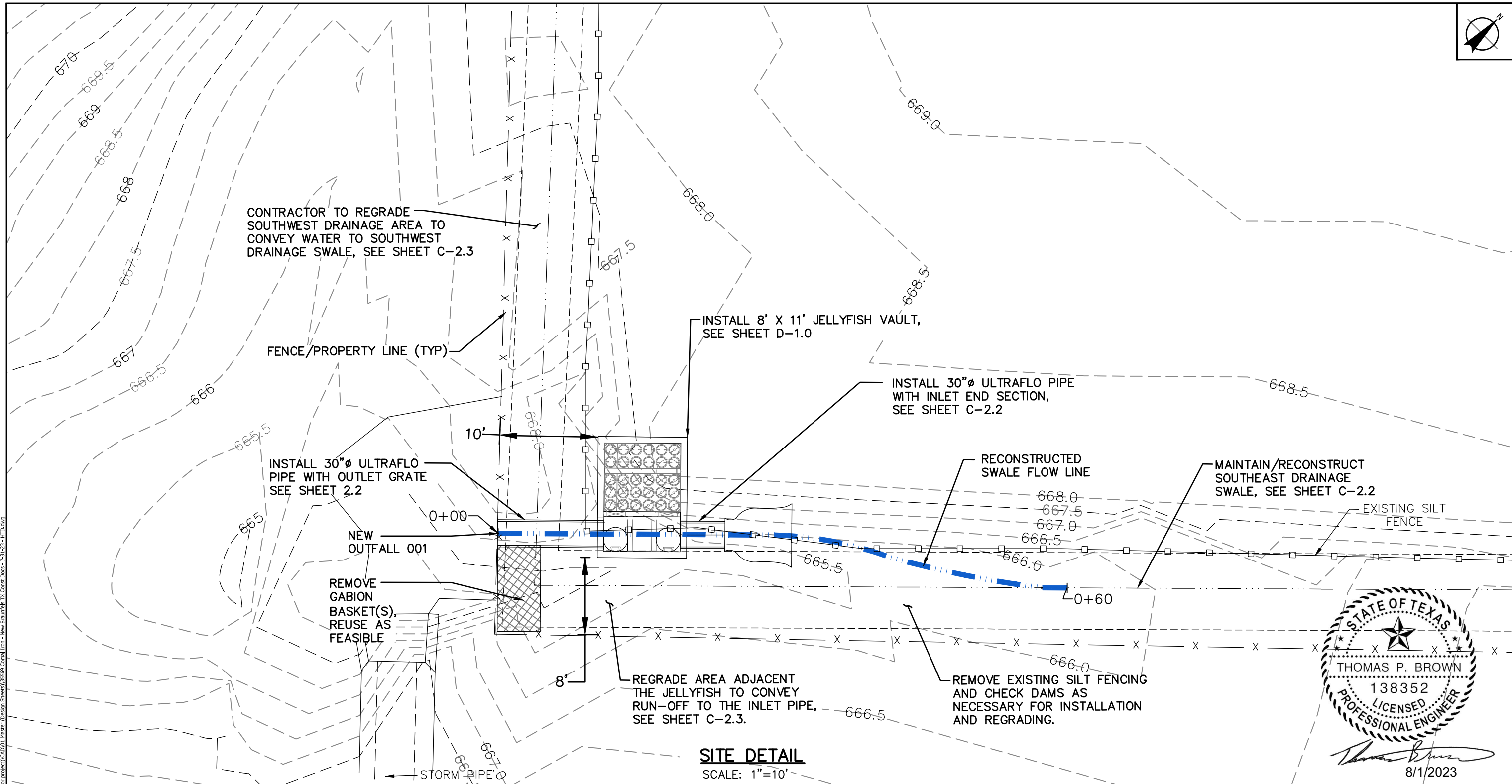

SITE DETAIL
SCALE: 1"=10'

STATE OF TEXAS
 THOMAS P. BROWN
 138352
 LICENSED PROFESSIONAL ENGINEER
 8/1/2023

LEGEND

- EXISTING SILT FENCE
- X — X — FENCE
- · · · — · · · — CENTERLINE OF EXISTING SWALES
- ■ ■ ■ — ■ ■ ■ — RECONSTRUCTED SOUTHWEST SWALE

NOTES:
 1. CONTRACTOR TO VERIFY ELEVATIONS PRIOR TO PERFORMING WORK. SURVEYING SHALL BE PERFORMED TO VERIFY FINISHED GRADES ARE TO THE LINES AND GRADES SPECIFIED IN DESIGN WITH A TOLERANCE OF -0.2 FT TO +0.0 FT.
 2. CONTRACTOR SHALL IDENTIFY AND LOCATE UTILITY LINES AND OTHER NEARBY STRUCTURES PRIOR TO PERFORMING WORK.
 3. CONTRACTOR SHALL INSTALL TEMPORARY EROSION CONTROL LOG DAMS AS REQUIRED AND AS DIRECTED BY THE OWNER OR ENGINEER DURING CONSTRUCTION.

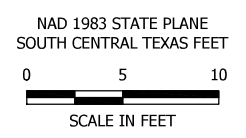

SHEET NUMBER
C-2.1

PROPOSED BMP SYSTEM SITE LAYOUT

STORM WATER RUN-OFF MODIFICATIONS
 FOR
COMAL IRON AND METALS
 1431 FM306
 NEW BRAUNFELS, TEXAS 78132

REQUESTED BY:	TB
DRAWN BY:	WM
DATE:	7/31/2023
PROJECT:	0888835569

ENSAFE
 Creative thinking. Custom solutions.
 800.588.7962 | www.ensafe.com

A:\Comal Iron - New Braunfels - 2023 Project Exec (Working drawings for project)\C-01 Master (Design Sheets)\35569 Comal Iron - New Braunfels TX Conts Docs - 7-31-23 - ITD.dwg

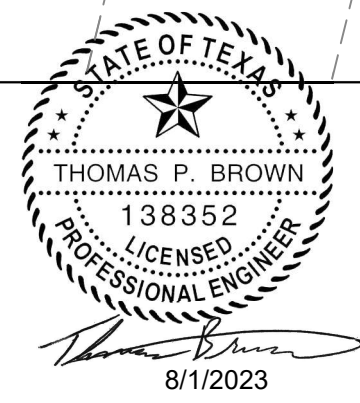
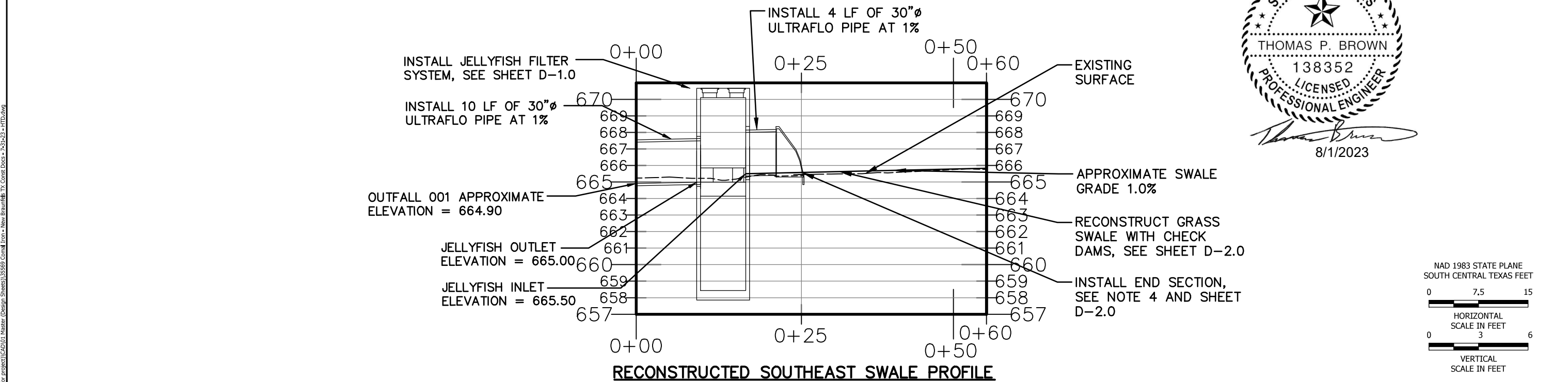
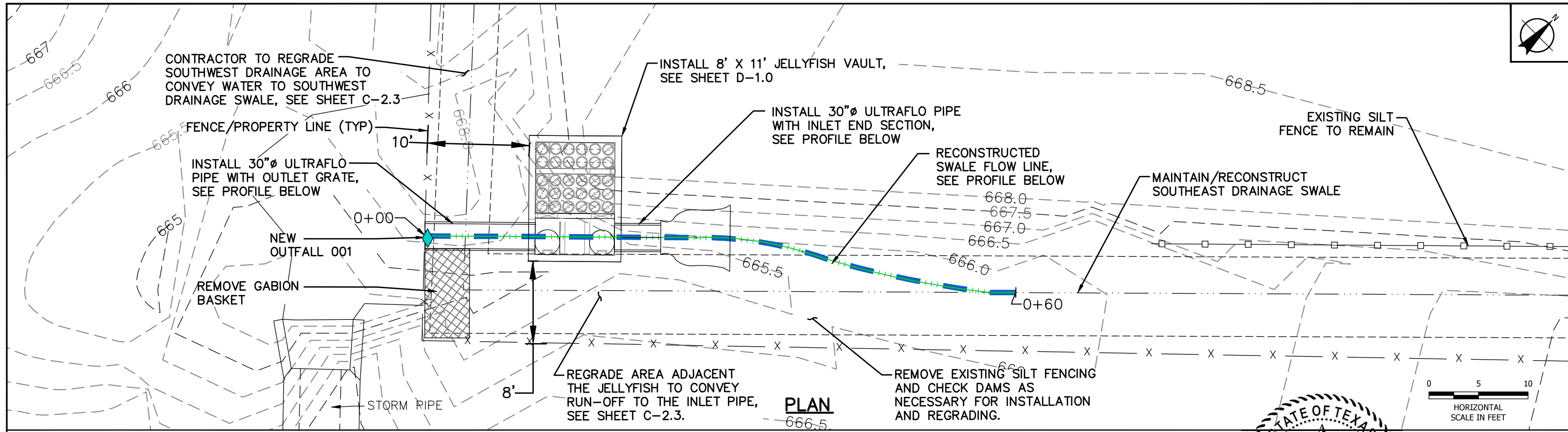

LEGEND

	EXISTING RAIL ROAD TRACK
	EXISTING SILT FENCE
	FENCE
	OUTFALL
	RECONSTRUCTED SOUTHWEST SWALE

- NOTES:**
- CONTRACTOR TO VERIFY ELEVATIONS PRIOR TO PERFORMING WORK. SURVEYING SHALL BE PERFORMED TO VERIFY FINISHED GRADES ARE TO THE LINES AND GRADES SPECIFIED IN DESIGN WITH A TOLERANCE OF -0.2 FT TO +0.0 FT.
 - CONTRACTOR SHALL IDENTIFY AND LOCATE UTILITY LINES AND OTHER NEARBY STRUCTURES PRIOR TO PERFORMING WORK.
 - PIPE LENGTHS DO NOT ACCOUNT FOR SLOPE OR CONNECTION LENGTH. CONTRACTOR TO DETERMINE REQUIRED PIPE LENGTH.
 - CONTRACTOR TO INSTALL TRASH GUARD AROUND END SECTION AS DIRECTED BY THE ENGINEER.
 - CONTRACTOR SHALL INSTALL TEMPORARY EROSION CONTROL LOG DAMS AS REQUIRED AND AS DIRECTED BY THE OWNER OR ENGINEER DURING CONSTRUCTION.
 - CONTRACTOR TO INSTALL REMOVABLE, LOCKABLE GRATE ON 30" OUTLET PIPE AT NEW OUTFALL 001.

RECONSTRUCTED SOUTHWEST SWALE PLAN - PROFILE

STORM WATER RUN-OFF MODIFICATIONS
FOR
COMAL IRON AND METALS
1431 FM306
NEW BRAUNFELS, TEXAS 78132

REQUESTED BY:	TB
DRAWN BY:	WM
DATE:	7/31/2023
PROJECT:	0888835569

ENSAFÉ
Creative thinking. Custom solutions.
800.588.7962 | www.ensafe.com

SHEET NUMBER
C-2.2

\\\Comal Iron - New Braunfels - 2023 Project Exec (Working drawings for project) CAD01 Master (Design Sheets) 35569 Comal Iron - New Braunfels TX Cont. Docs - 7-31-23 - IFT.dwg

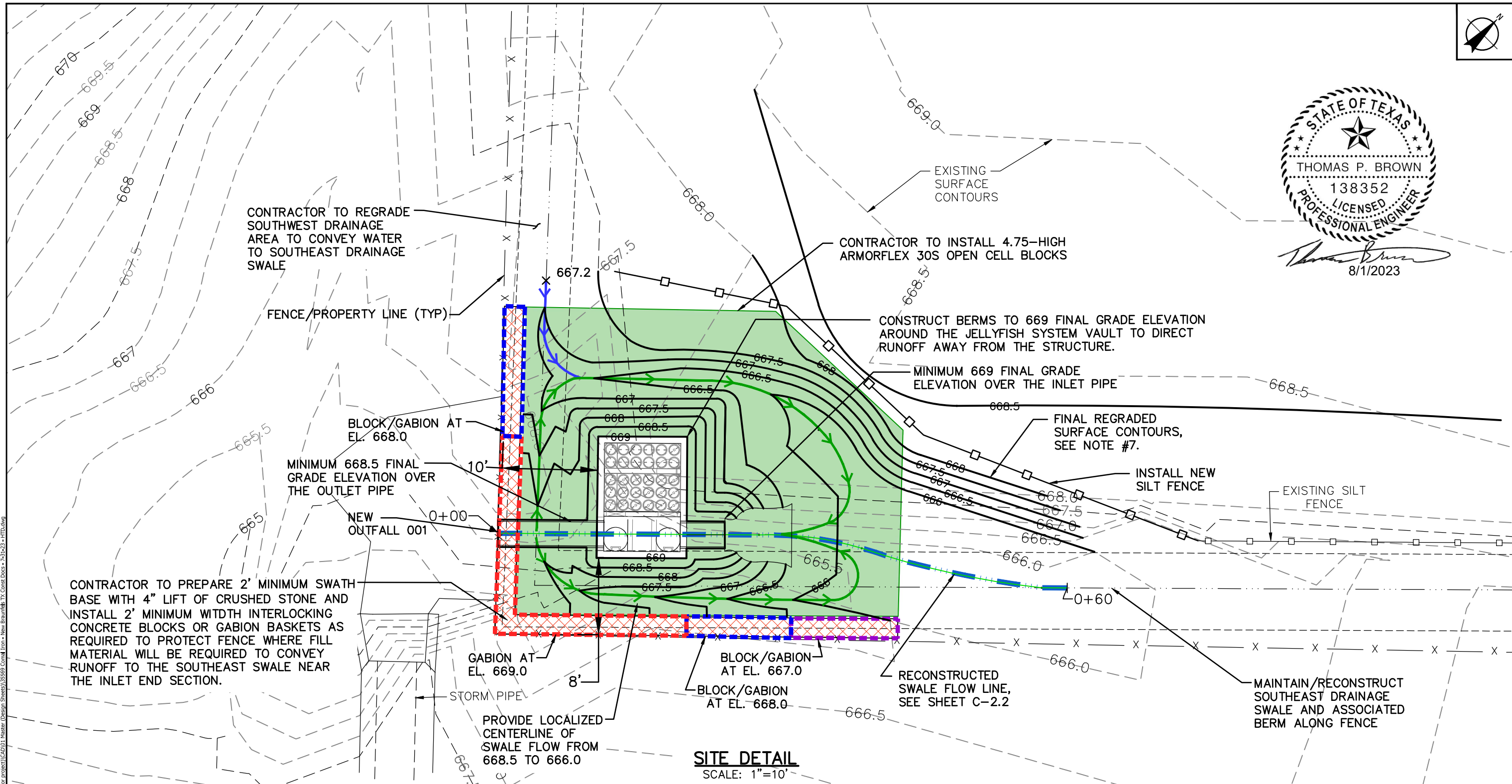
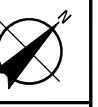

SITE DETAIL
SCALE: 1"=10'

LEGEND

	EXISTING SILT FENCE
	FENCE
	CENTERLINE OF EXISTING SWALES
	RECONSTRUCTED SOUTHEAST SWALE
	LOCALIZED DRAINAGE SWALES
	SOUTH CORNER DRAINAGE SWALES
	PROPOSED CONTOUR

- NOTES:**
- CONTRACTOR TO VERIFY ELEVATIONS PRIOR TO PERFORMING WORK. SURVEYING SHALL BE PERFORMED TO VERIFY FINISHED GRADES ARE TO THE LINES AND GRADES SPECIFIED IN DESIGN WITH A TOLERANCE OF -0.2 FT TO +0.0 FT.
 - CONTRACTOR SHALL IDENTIFY AND LOCATE UTILITY LINES AND OTHER NEARBY STRUCTURES PRIOR TO PERFORMING WORK.
 - CONTRACTOR TO SEED, MULCH, AND INSTALL GEOTEXTILE EROSION CONTROL BLANKETS ON LOW SLOPED AREAS AS DIRECTED BY THE OWNER OR ENGINEER.
 - CONTRACTOR TO INSTALL 6-OUNCE NON-WOVEN GEOTEXTILE FILTER FABRIC AND 2"-4" RIPRAP ON MODERATE SLOPES AREAS AS DIRECTED BY THE OWNER OR ENGINEER.
 - CONTRACTOR TO MATCH ELEVATIONS AROUND VAULT AND CREATE BERMS AS PER TYPICAL SOUTH CORNER SWALE SECTION DETAIL SHOWN ON SHEET D-2.0.
 - CONTRACTOR TO INSTALL AMORFLEX 30S OPEN CELL BLOCKS AS SHOWN. OPEN SPACE TO BE BACKFILLED WITH STOP SOIL AND SEEDED WITH NATIVE GRASS MIX.
 - CONTRACTOR TO PLACE ANY EXCESS SOILS FROM THE EXCAVATION FOR THE JELLYFISH AS DIRECTED BY THE OWNER OR ENGINEER.

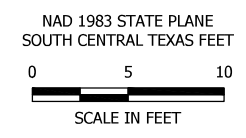

SHEET NUMBER
C-2.3

PROPOSED BMP SYSTEM SITE REGRADED PLAN

STORM WATER RUN-OFF MODIFICATIONS FOR
COMAL IRON AND METALS
1431 FM306
NEW BRAUNFELS, TEXAS 78132

REQUESTED BY:	TB
DRAWN BY:	WM
DATE:	7/31/2023
PROJECT:	0888835569

ENSAFÉ
Creative thinking. Custom solutions.
800.588.7962 | www.ensafe.com

C:\Comal Iron - New Braunfels - 2023 Project Exec (Working drawings for project)\C-01 Master (Design Sheets)\35569 Comal Iron - New Braunfels TX Contour Docs - 7-31-23 - ITD.dwg

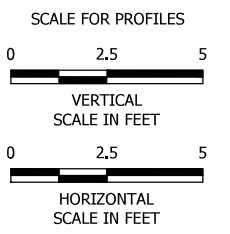
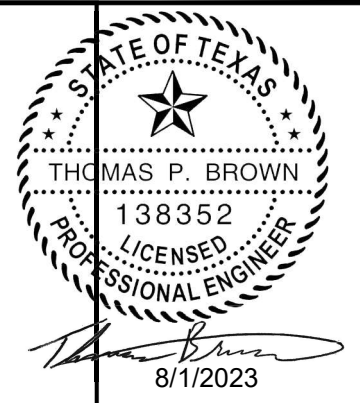
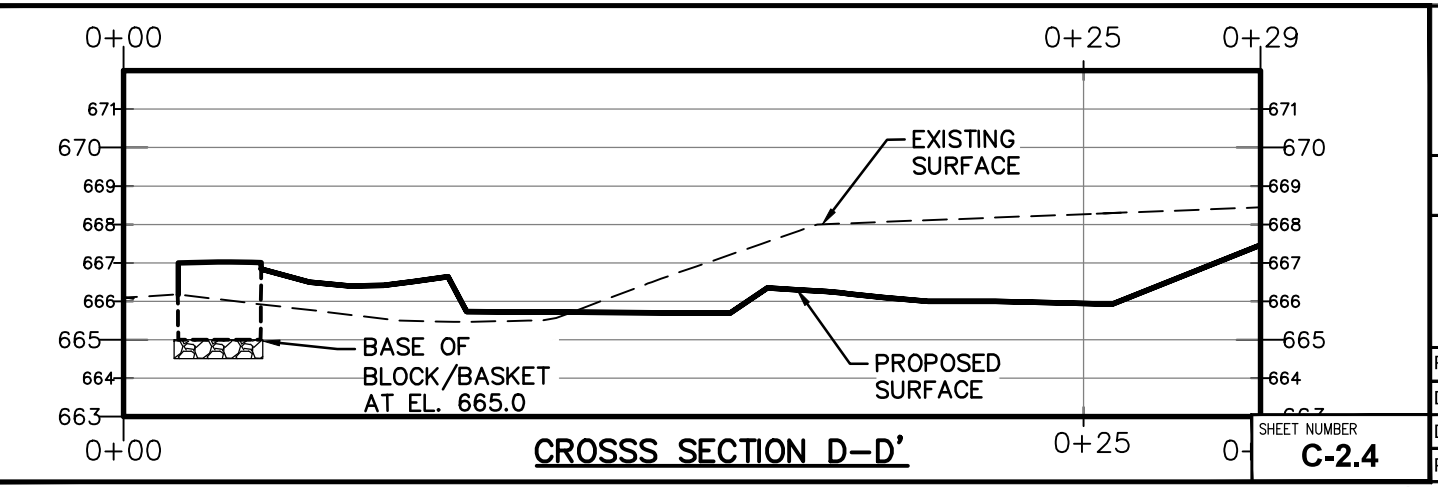
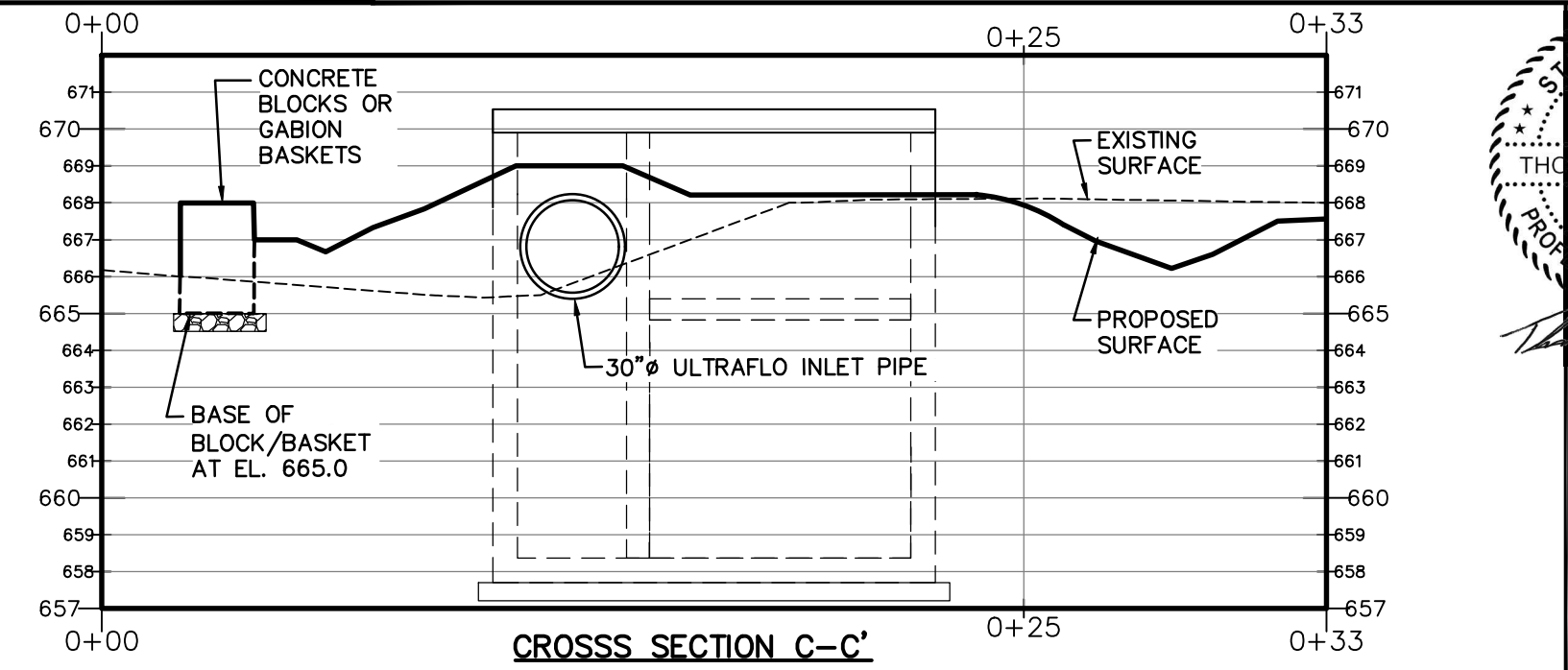
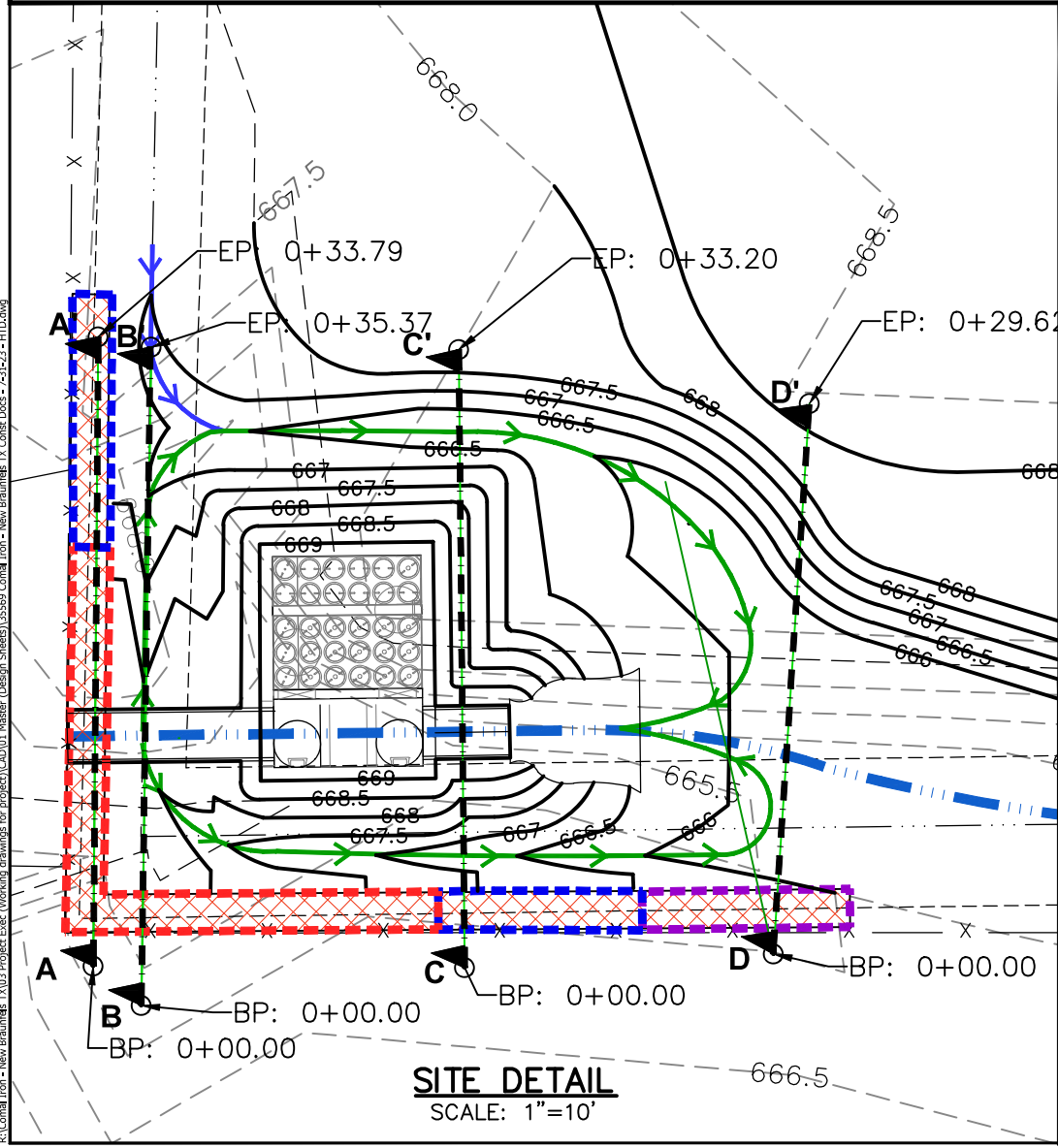
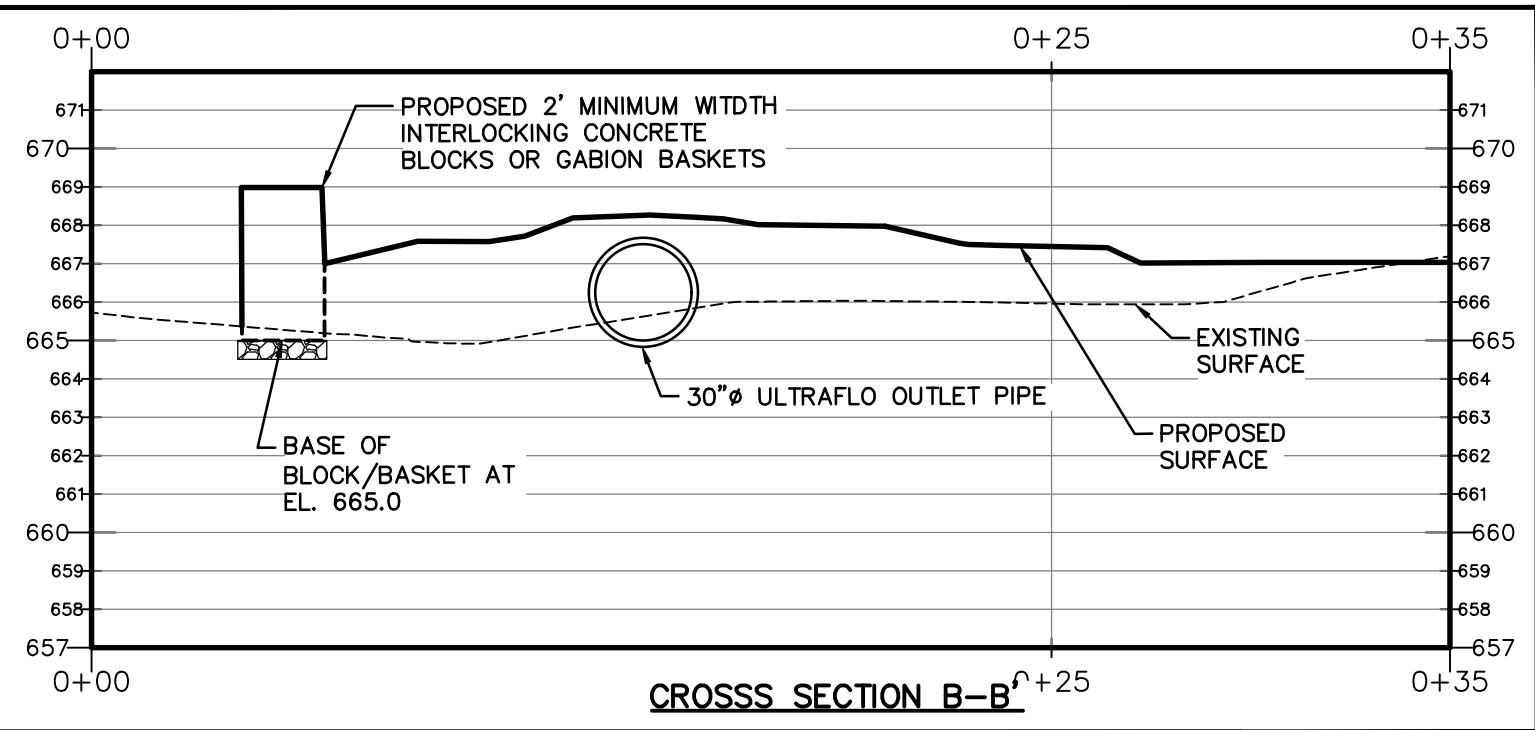
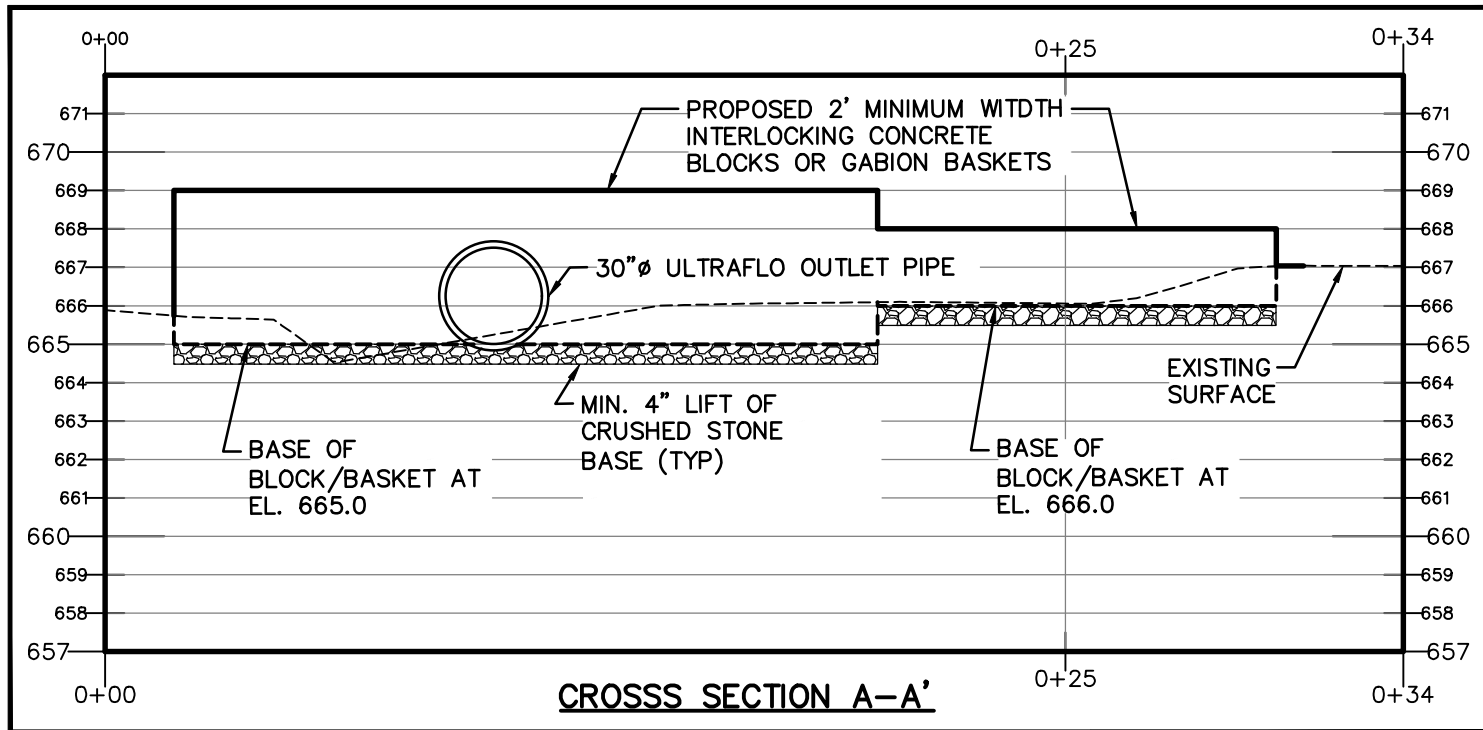

PROPOSED SITE REGRADING CROSS SECTIONS	
STORM WATER RUN-OFF MODIFICATIONS FOR COMAL IRON AND METALS 1431 FM306 NEW BRAUNFELS, TEXAS 78132	
REQUESTED BY:	TB
DRAWN BY:	WM
DATE:	7/31/2023
PROJECT:	0888835569



SHEET NUMBER
C-2.4

C:\Comal Iron - New Braunfels - 2023 Project Exec (Location drawings for project)\CAD\01 Master (Design Sheets)\35569 Comal Iron - New Braunfels TX Comp Docs - 7-31-23 - 1110.dwg

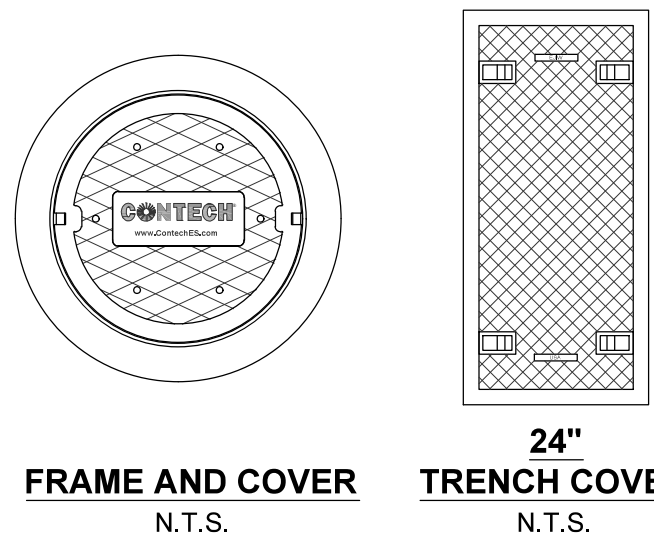
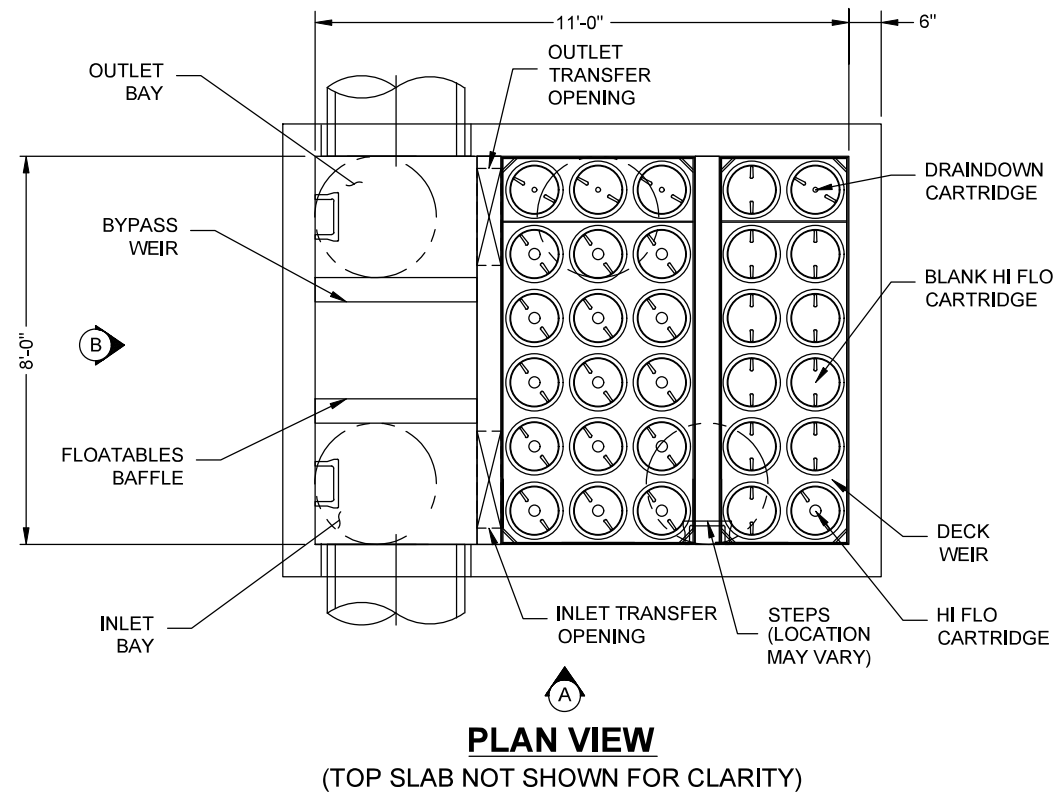

SITE SPECIFIC DATA REQUIREMENTS				
STRUCTURE ID	JELLYFISH			
WATER QUALITY FLOW RATE (cfs)	3.19			
PEAK FLOW RATE (cfs)	36.3			
RETURN PERIOD OF PEAK FLOW (yrs)	100			
# OF CARTRIDGES REQUIRED (HF / DD)	16/4			
CARTRIDGE LENGTH	54			
PIPE DATA:	I.E.	MAT'L	DIA	SLOPE
INLET #1	665.50	ULTRAFLO	30"	1%
OUTLET	665.00	ULTRAFLO	30"	1%
RIM ELEVATION	670.67			

PLAN VIEW
(TOP SLAB NOT SHOWN FOR CLARITY)

GENERAL NOTES:

1. CONTECH TO PROVIDE ALL JELLYFISH SYSTEM MATERIALS UNLESS NOTED OTHERWISE.
2. CONTRACTOR TO CONFIRM STRUCTURE MEETS CONTECH DESIGNED SPECIFICATIONS FOR JELLYFISH JFPD0811 SYSTEM.
3. CASTINGS SHALL MEET AASHTO M306 LOAD RATING AND BE CAST WITH THE CONTECH LOGO.
4. STRUCTURE SHALL BE PRECAST CONCRETE CONFORMING TO ASTM C-857, ASTM C-918, AND AASHTO LOAD FACTOR DESIGN METHOD.
5. OUTLET PIPE INVERT IS EQUAL TO THE CARTRIDGE DECK ELEVATION.
6. CONTRACTOR TO VERIFY ALL INSTALLATION ELEVATIONS IN THE FIELD WITH ENGINEER OF RECORD PRIOR TO PLACING THE STRUCTURE.
7. CONTRACTOR TO PERFORM SITE REGRADING BASED ON FIELD CONDITIONS AS DIRECTED BY THE OWNER OR ENGINEER.
8. CONTRACTOR TO INSTALL 8" OF CRUSHED STONE BELOW THE JELLYFISH VAULT UNLESS SUBGRADE IS CLAY OR BEDROCK. CONTRACTOR TO INSTALL 24" OF CRUSHED STONE BASE AS DIRECTED BY ENGINEER IF CLAY SOIL IS PRESENT. IF BEDROCK IS PRESENT, CONTRACTOR MAY INSTALL LESS THAN 8" OF CRUSHED STONE BASE AS DIRECTED BY ENGINEER.

INSTALLATION NOTES

- A. ANY SUB BASE AND BACKFILL MATERIAL SHALL BE PLACED BY CONTRACTOR AND COMPACTED TO A MINIMUM 95% RELATIVE COMPACTION. A MINIMUM OF 12 INCHES OF CLASS 5 GRAVEL SHALL BE PLACED AROUND THE SIDES OF THE JELLYFISH VAULT AS DIRECTED BY ENGINEER.
- B. CONTRACTOR TO PROVIDE EQUIPMENT WITH SUFFICIENT LIFTING AND REACH CAPACITY TO LIFT AND SET THE STRUCTURE.
- C. CONTRACTOR WILL INSTALL AND LEVEL THE STRUCTURE, SEALING THE JOINTS, LINE ENTRY AND EXIT POINTS (NON-SHRINK GROUT WITH APPROVED WATERSTOP OR FLEXIBLE BOOT).
- D. CARTRIDGE INSTALLATION, BY CONTECH, SHALL OCCUR ONLY AFTER SITE HAS BEEN STABILIZED AND THE JELLYFISH UNIT IS CLEAN AND FREE OF DEBRIS. CONTACT CONTECH TO COORDINATE CARTRIDGE INSTALLATION WITH SITE STABILIZATION.

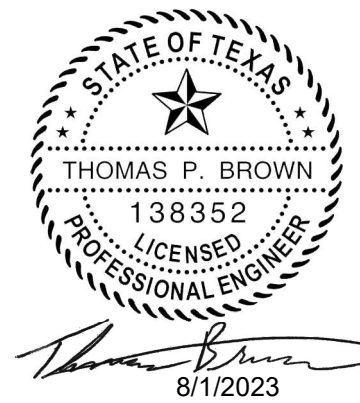
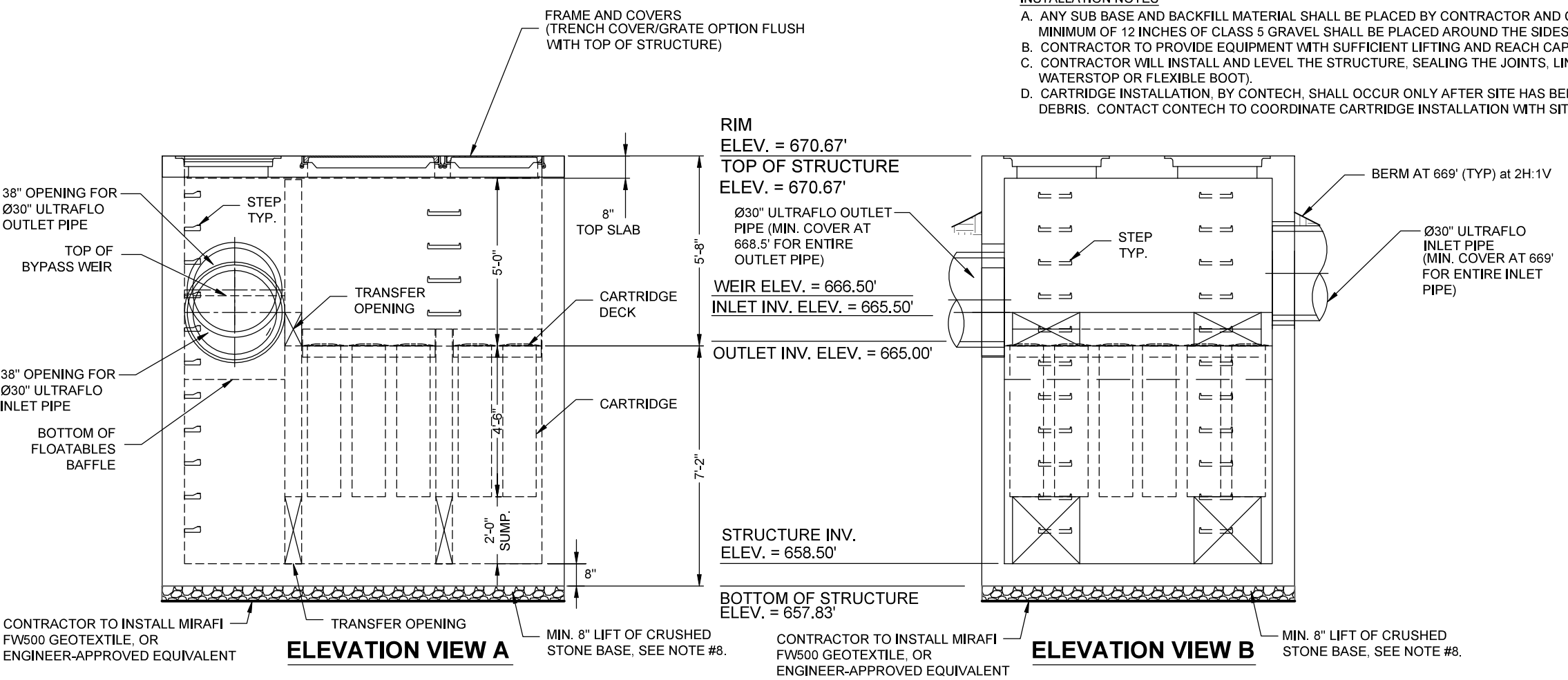

JELLYFISH JFPD0811 DETAILS
STORM WATER RUN-OFF MODIFICATIONS
 FOR
COMAL IRON AND METALS
 1431 FM306
 NEW BRAUNFELS, TEXAS 78132

REQUESTED BY:	TB	ENSAFE Creative thinking. Custom solutions. 800.588.7962 www.ensafe.com
DRAWN BY:	WM	
DATE:	7/31/2023	
PROJECT:	0888835569	

SHEET NUMBER
D-1.0

C:\Comal Iron - New Braunfels - 2023 Project Exec (Working drawings for project)\CAD\01 - Master (Design Sheets)\35569 Comal Iron - New Braunfels, TX Comal Docs - 23123 - JFD.dwg

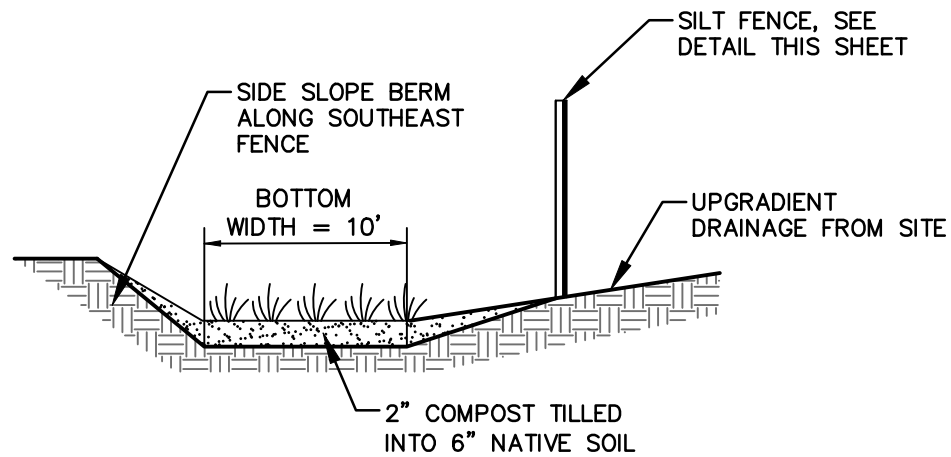

TYPICAL SWALE SECTION DETAIL
SCALE: NTS

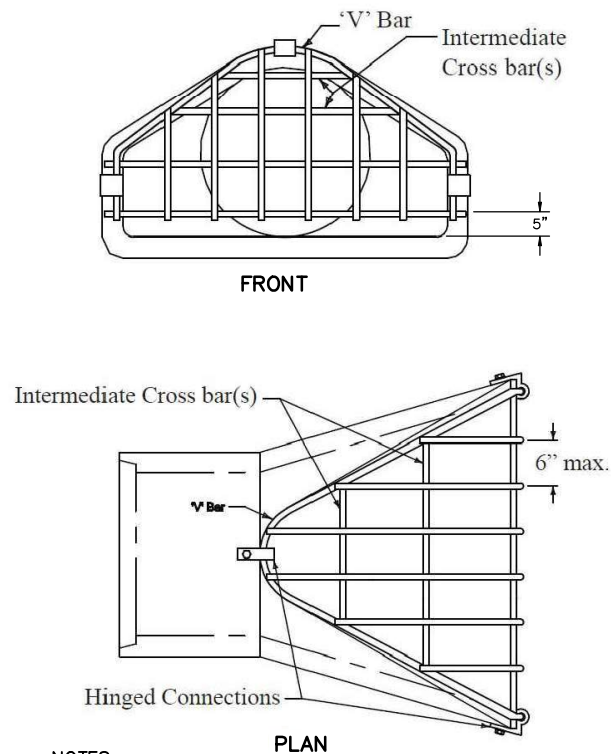

NOTES:
1. BOLTS FOR HINGED CONNECTIONS TO BE GALVANIZED $\frac{3}{8}$ " GRADE 8. BARS SIZE TO BE $\frac{3}{4}$ " GALVANIZED PER ASTM A123.

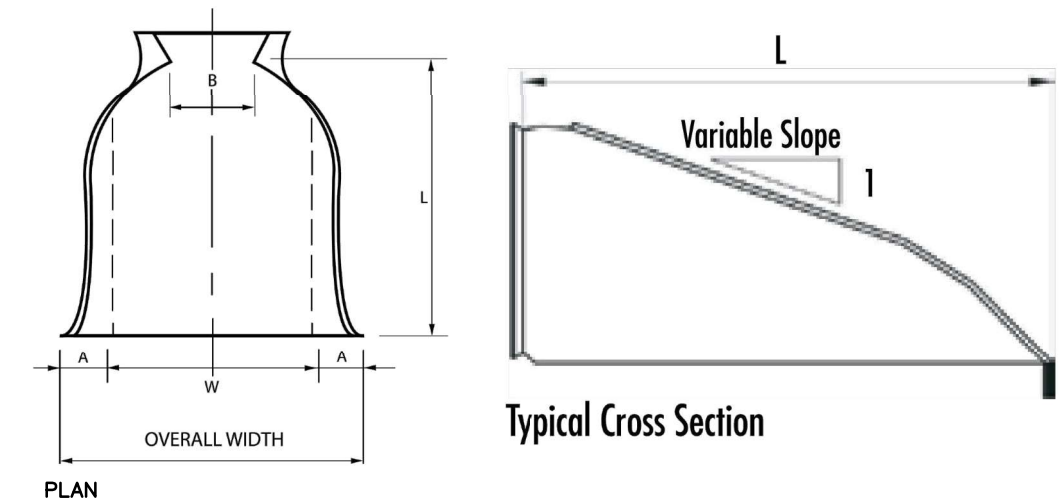

APPROXIMATE DIMENSIONS, INCHES							
Pipe Diameter	Gage	A (+/- 1")	B (Max)	H (Min)	L (+/- 2")	W (+/- 2")	Overall Width (+/- 4")
30	14	12	16	8	51	60	84

END SECTION AND TRASH GUARD DETAIL
SCALE: NTS

NOTES:
1. THE GUIDELINES SHOWN HEREON ARE SUGGESTIONS ONLY AND MAY BE MODIFIED BY THE ENGINEER.

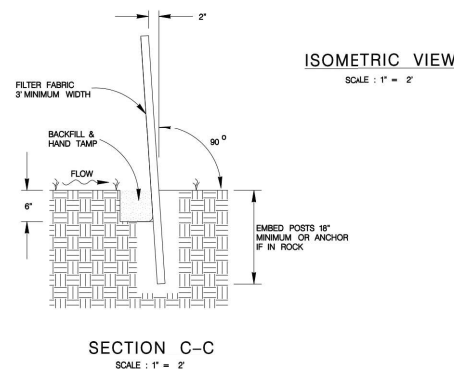
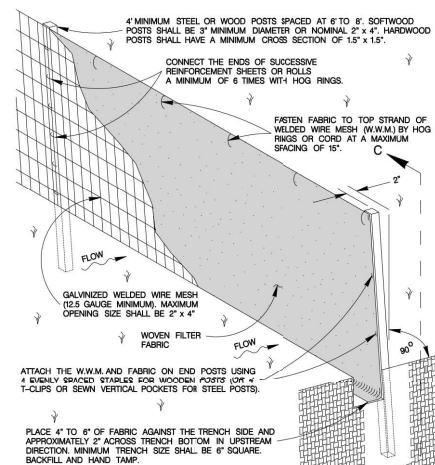

SILT FENCE DETAIL
SCALE: NTS

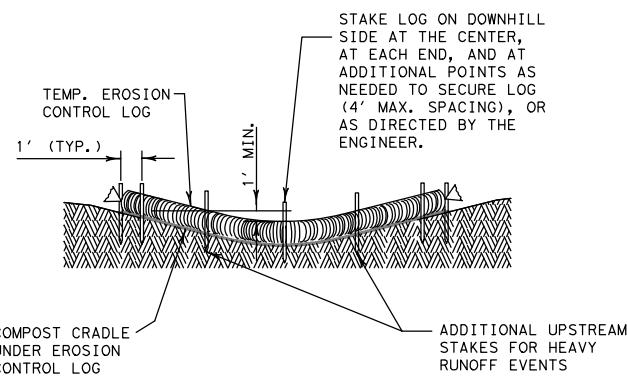
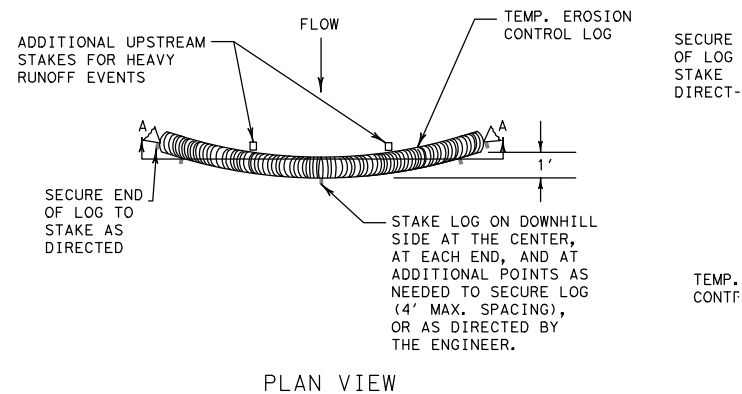

EROSION CONTROL LOG DAM DETAIL
SCALE: NTS

GENERAL NOTES

1. EROSION CONTROL LOGS SHALL BE INSTALLED IN ACCORDANCE WITH MANUFACTURER'S RECOMMENDATIONS, OR AS DIRECTED BY THE ENGINEER.
2. LENGTHS OF EROSION CONTROL LOGS SHALL BE IN ACCORDANCE WITH MANUFACTURER'S RECOMMENDATIONS AND AS REQUIRED FOR THE PURPOSE INTENDED.
3. UNLESS OTHERWISE DIRECTED, USE BIODEGRADABLE OR PHOTODEGRADABLE CONTAINMENT MESH ONLY WHERE LOG WILL REMAIN IN PLACE AS PART OF A VEGETATIVE SYSTEM. FOR TEMPORARY INSTALLATIONS, USE RECYCLABLE CONTAINMENT MESH.
4. FILL LOGS WITH SUFFICIENT FILTER MATERIAL TO ACHIEVE THE MINIMUM COMPACTED DIAMETER SPECIFIED BY THE OWNER OR ENGINEER.
5. STAKES SHALL BE 2" X 2" WOOD 2'-4' LONG, EMBEDDED SUCH THAT 2" PROTRUDES ABOVE LOG, OR AS DIRECTED BY THE OWNER OR ENGINEER.
6. DO NOT PLACE STAKES THROUGH CONTAINMENT MESH.

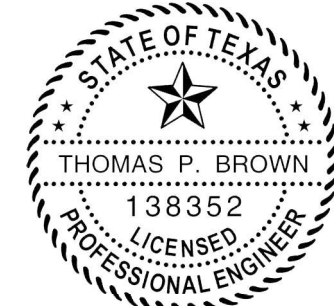

Thomas P. Brown
8/1/2023

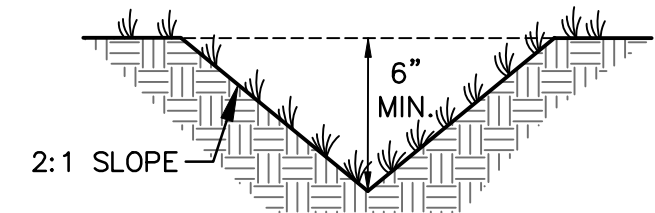

TYPICAL SOUTH CORNER SWALE SECTION
SCALE: NTS

NOTES:
1. CONTRACTOR TO INSTALL 6-OUNCE NON-WOVEN GEOTEXTILE FILTER FABRIC AND ARMOR THE 18" ULTRAFLO END SECTION WITH 5" - 8" RIPRAP.

GENERAL DETAILS

STORM WATER RUN-OFF MODIFICATIONS FOR COMAL IRON AND METALS 1431 FM306 NEW BRAUNFELS, TEXAS 78132

REQUESTED BY: TB
DRAWN BY: WM
DATE: 7/31/2023
PROJECT: 088835569

ENSAFE
Creative thinking. Custom solutions.
800.588.7962 | www.ensafe.com

SHEET NUMBER
D-2.0



Section 6: Comal Iron and Metals – Permanent Stormwater Section
(TCEQ - 0600)

ATTACHMENT G

Comal Iron and Metals – Inspection, Maintenance, Repair, and
Retrofit Plan

Activation, inspection, and maintenance instructions are outlined in Attachment C, section 6.



Section 6: Comal Iron and Metals – Permanent Stormwater Section
(TCEQ - 0600)

ATTACHMENT H

Comal Iron and Metals – Pilot-Scale Field Testing Plan

The BMPs is recognized by the Executive Director therefore a Pilot-Scale Field Testing Plan is not required.



Section 6: Comal Iron and Metals – Permanent Stormwater Section (TCEQ - 0600)

ATTACHMENT I

Comal Iron and Metals – Measures for Minimizing Surface Stream Contamination

This attachment does not apply to this submittal. There are no surface streams at the project site; therefore, measures for minimizing surface stream contamination are proposed at this time.



Section 7

Comal Iron and Metals – Aboveground Storage Tank Facility Plan
Application (TCEQ - 0575)

Aboveground Storage Tank Facility Plan Application

Texas Commission on Environmental Quality

For Permanent Storage on The Edwards Aquifer Recharge and Transition Zones And Relating to 30 TAC §213.5(e), Effective June 1, 1999

To ensure that the application is administratively complete, confirm that all fields in the form are complete, verify that all requested information is provided, consistently reference the same site and contact person in all forms in the application, and ensure forms are signed by the appropriate party.

Note: Including all the information requested in the form and attachments contributes to more streamlined technical reviews.

Signature

To the best of my knowledge, the responses to this form accurately reflect all information requested concerning the proposed regulated activities and methods to protect the Edwards Aquifer. This **Aboveground Storage Tank Facility Plan Application** is hereby submitted for TCEQ review and Executive Director approval. The application was prepared by:

Print Name of Customer/Agent: Comal Iron and Metals/Adriana Lee

Date: 10/11/2022

Signature of Customer/Agent:



Regulated Entity Name: Comal Iron and Metals

Aboveground Storage Tank (AST) Facility Information

1. Tanks and substance stored:

Table 1 - Tank and Substance Storage

<i>AST Number</i>	<i>Size (Gallons)</i>	<i>Substance to be Stored</i>	<i>Tank Material</i>
1	240	Used Oil	Double-walled
2	165	Hydraulic Fluid	Metal Tank Plastic IBC Tote
3	165	Motor Oil	Plastic IBC Tote
4	55	Antifreeze	Metal Drum

<i>AST Number</i>	<i>Size (Gallons)</i>	<i>Substance to be Stored</i>	<i>Tank Material</i>
5	55	Diesel Exhaust Fluid	Metal Drum

Total x 1.5 = 680 Gallons

2. The AST will be placed within a containment structure that is sized to capture one and one-half (1 1/2) times the storage capacity of the system. For facilities with more than one tank system, the containment structure is sized to capture one and one-half (1 1/2) times the cumulative storage capacity of all systems.

Attachment A - Alternative Methods of Secondary Containment. Alternative methods for providing secondary containment are proposed. Specifications that show equivalent protection for the Edwards Aquifer are attached.

3. Inside dimensions and capacity of containment structure(s):

Table 2 - Secondary Containment

<i>Length (L) (Ft.)</i>	<i>Width (W) (Ft.)</i>	<i>Height (H) (Ft.)</i>	<i>L x W x H = (Ft3)</i>	<i>Gallons</i>
122"	78"	10"	95,160	411
62"	62"	26"	99,944	432 x 2 Systems
57"	33"	8.105"	15,246	66

Total: 1,341 Gallons

4. All piping, hoses, and dispensers will be located inside the containment structure.
 Some of the piping to dispensers or equipment will extend outside the containment structure.
 The piping will be aboveground
 The piping will be underground
5. The containment area must be constructed of and in a material impervious to the substance(s) being stored. The proposed containment structure will be constructed of Concrete or plastic
6. **Attachment B - Scaled Drawing(s) of Containment Structure.** A scaled drawing of the containment structure that shows the following is attached:
 Interior dimensions (length, width, depth and wall and floor thickness).
 Internal drainage to a point convenient for the collection of any spillage.
 Tanks clearly labeled.
 Piping clearly labeled.
 Dispenser clearly labeled.

Site Plan Requirements

Items 7 - 18 must be included on the Site Plan.

7. The Site Plan must have a minimum scale of 1" = 400'.
Site Plan Scale: 1" = 200 and 400
8. 100-year floodplain boundaries:
- Some part(s) of the project site is located within the 100-year floodplain. The floodplain is shown and labeled.
 - No part of the project site is located within the 100-year floodplain.
 - The 100-year floodplain boundaries are based on the following specific (including date of material) sources(s): FEMA Floodplain Information
9. The layout of the development is shown with existing and finished contours at appropriate, but not greater than ten-foot contour intervals. Show lots, recreation centers, buildings, roads, etc.
- The layout of the development is shown with existing contours. Finished topographic contours will not differ from the existing topographic configuration and are not shown.
10. All known wells (oil, water, unplugged, capped and/or abandoned, test holes, etc.):
- There are 1 (#) wells present on the project site and the locations are shown and labeled. (Check all of the following that apply):
 - The wells are not in use and have been properly abandoned.
 - The wells are not in use and will be properly abandoned.
 - The wells are in use and comply with 16 TAC § 76.
 - There are no wells or test holes of any kind known to exist on the project site.
11. Geologic or manmade features which are on the site:
- All sensitive geologic or manmade features identified in the Geologic Assessment are shown and labeled.
 - No sensitive geologic or manmade features were identified in the Geologic Assessment.
 - Attachment C - Exception to the Geologic Assessment.** A request and justification for an exception to a portion of the Geologic Assessment is attached.
12. The drainage patterns and approximate slopes anticipated after major grading activities.
13. Areas of soil disturbance and areas which will not be disturbed.
14. Locations of major structural and nonstructural controls. These are the temporary and permanent best management practices.

- 15. Locations where soil stabilization practices are expected to occur.
- 16. Surface waters (including wetlands).
 N/A
- 17. Locations where stormwater discharges to surface water or sensitive features.
 There will be no discharges to surface water or sensitive features.
- 18. Legal boundaries of the site are shown.

Best Management Practices

- 19. Any spills must be directed to a point convenient for collection and recovery. Spills from storage tank facilities must be removed from the controlled drainage area for disposal within 24 hours of the spill.
 - In the event of a spill, any spillage will be removed from the containment structure within 24 hours of the spill and disposed of properly.
 - In the event of a spill, any spillage will be drained from the containment structure through a drain and valve within 24 hours of the spill and disposed of properly. The drain and valve system are shown in detail on the scaled drawing.
- 20. All stormwater accumulating inside the containment structure will be disposed of through an authorized waste disposal contractor.
 - Containment area will be covered by a roof.
 - Containment area will not be covered by a roof.
 - A description of the alternate method of stormwater disposal is submitted for the executive director's review and approval and is attached.
- 21. **Attachment D - Spill and Overfill Control.** A site-specific description of the methods to be used at the facility for spill and overfill control is attached.
- 22. **Attachment E - Response Actions to Spills.** A site-specific description of the planned response actions to spills that will take place at the facility is attached.

Administrative Information

- 23. A Water Pollution Abatement Plan (WPAP) is required for construction of any associated commercial, industrial or residential project located on the Recharge Zone.
 - The WPAP application for this project was approved by letter dated _____. A copy of the approval letter is attached at the end of this application.
 - The WPAP application for this project was submitted to the TCEQ on 07/07/2023, but has not been approved.
 - A WPAP application is required for an associated project, but it has not been submitted.

- There will be no building or structure associated with this project. In the event a building or structure is needed in the future, the required WPAP will be submitted to the TCEQ.
 - The proposed AST is located on the Transition Zone and a WPAP is not required. Information requested in 30 TAC 213.5 subsection (b) (4)(B) and (C) and (5) is provided with this application. (Forms TCEQ-0600 Permanent Stormwater Section and TCEQ-0602 Temporary Stormwater Section or Stormwater Pollution Prevention Plan/SW3P).
24. This facility is subject to the requirements for the reporting and cleanup of surface spills and overfills pursuant to 30 TAC 334 Subchapter D relating to Release Reporting and Corrective Action.
25. Submit one (1) original and one (1) copy of the application, plus additional copies as needed for each affected incorporated city, groundwater conservation district, and county in which the project will be located. The TCEQ will distribute the additional copies to these jurisdictions. The copies must be submitted to the appropriate regional office.
26. Any modification of this AST Facility Plan application will require executive director approval, prior to construction, and may require submission of a revised application, with appropriate fees.



Section 7: Aboveground Storage Tank Facility Plan Application
(TCEQ - 0575)

ATTACHMENT A

Comal Iron and Metals – Alternative Methods of Secondary
Containment

This attachment does not apply to this submittal. No alternative methods of secondary containment are proposed at this time.



Section 7: Aboveground Storage Tank Facility Plan Application
(TCEQ - 0575)

ATTACHMENT B

Comal Iron and Metals – Scaled Drawing(s) of Containment
Structure

LEGEND

→ DIRECTION OF SURFACE RUNOFF

 BUILDING

 COVERED AREA

 SECONDARY CONTAINMENT

SCALE

1:31"

1	500-GALLON TANK	USED OIL
2	165-GALLON TOTE	HYDRAULIC FLUID
3	165-GALLON TOTE	MOTOR OIL
4	55-GALLON DRUM	ANTIFREEZE
5	55-GALLON DRUM	DEF

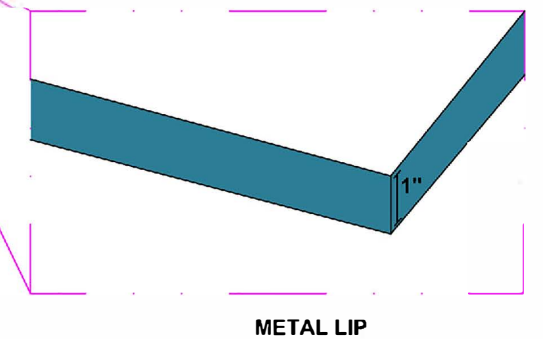
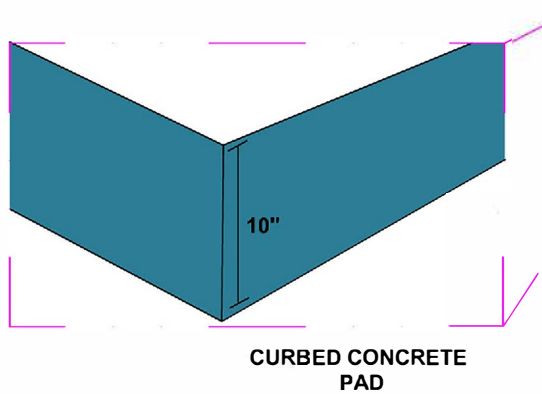
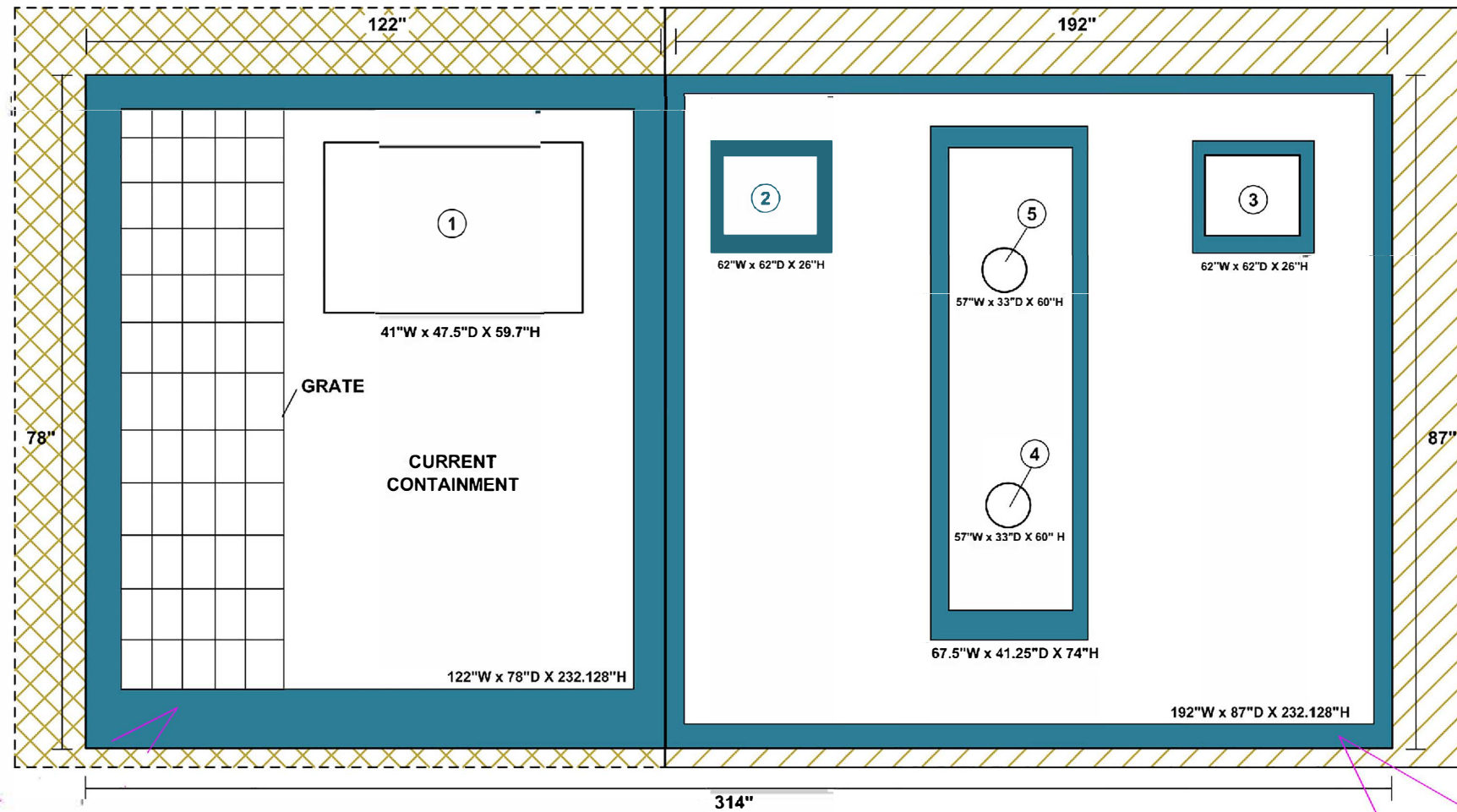

JAMES ENVIRONMENTAL MANAGEMENT, INC. PO BOX 1323 GEORGETOWN, TEXAS 78627 <small>Google Verified</small>		SITE PLAN		SCALE	1:31"	511-777
		COMAL IRON & METALS, INC.		DRAFTED/MODIFIED	MH	FIG 4
		NEW BRAUNFELS, TEXAS		INSPECTION DATE	04/22	



Section 7: Aboveground Storage Tank Facility Plan Application (TCEQ - 0575)

ATTACHMENT C

Comal Iron and Metals – Exception to the Geologic Assessment

This attachment does not apply to this submittal. An exception to the required Geologic Assessment is not required. A Geological Assessment of the project site was completed and is included in this submittal; see Section 3 of this report.



Section 7: Aboveground Storage Tank Facility Plan Application (TCEQ - 0575)

ATTACHMENT D

Comal Iron and Metals – Spill and Overfill Control

Personnel in charge of loading/unloading tanks will be trained to utilize proper techniques and preventive measures to avoid spills. The tank levels will be checked prior to loading/unloading and the operator will be present at all times during tank loading/unloading. The tank will be monitored as it is filled, either visually or in another manner, dependent upon the indicator present the tank.



Section 7: Aboveground Storage Tank Facility Plan Application (TCEQ - 0575)

ATTACHMENT E

Comal Iron and Metals – Response Actions to Spills

See Section 5 – A: Spill Response Actions, for a detailed description of the Edward's Aquifer recommended response procedures.



Section 8

Comal Iron and Metals – Agent Authorization Form (TCEQ - 0599) &
Property Owner Deed

Agent Authorization Form
For Required Signature
Edwards Aquifer Protection Program
Relating to 30 TAC Chapter 213
Effective June 1, 1999

I Marcela Rodriguez
Print Name

CEO
Title - Owner/President/Other

of Comal Iron & Metals
Corporation/Partnership/Entity Name

have authorized Adriana Lee
Print Name of Agent/Engineer

of James Environmental Mgt
Print Name of Firm

to represent and act on the behalf of the above named Corporation, Partnership, or Entity for the purpose of preparing and submitting this plan application to the Texas Commission on Environmental Quality (TCEQ) for the review and approval consideration of regulated activities.

I also understand that:

1. The applicant is responsible for compliance with 30 Texas Administrative Code Chapter 213 and any condition of the TCEQ's approval letter. The TCEQ is authorized to assess administrative penalties of up to \$10,000 per day per violation.
2. For those submitting an application who are not the property owner, but who have the right to control and possess the property, additional authorization is required from the owner.
3. Application fees are due and payable at the time the application is submitted. The application fee must be sent to the TCEQ cashier or to the appropriate regional office. The application will not be considered until the correct fee is received by the commission.
4. A notarized copy of the Agent Authorization Form must be provided for the person preparing the application, and this form must accompany the completed application.
5. No person shall commence any regulated activity on the Edwards Aquifer Recharge Zone, Contributing Zone or Transition Zone until the appropriate application for the activity has been filed with and approved by the Executive Director.

SIGNATURE PAGE:

[Signature]
Applicant's Signature

10.24.22
Date

THE STATE OF TEXAS §

County of COMAL §

BEFORE ME, the undersigned authority, on this day personally appeared MARCELA RODRIGUEZ known to me to be the person whose name is subscribed to the foregoing instrument, and acknowledged to me that (s)he executed same for the purpose and consideration therein expressed.

GIVEN under my hand and seal of office on this 24th day of OCTOBER, 2022

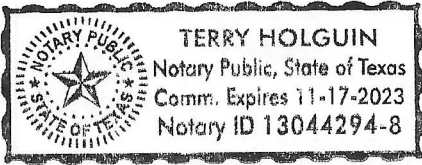

[Signature]
NOTARY PUBLIC

TERRY HOLGUIN
Typed or Printed Name of Notary

MY COMMISSION EXPIRES: 11/17/23

Deed Recordation Affidavit
Edwards Aquifer Protection Plan

THE STATE OF TEXAS §

County of Comal §

BEFORE ME, the undersigned authority, on this day personally appeared _____ who, being duly sworn by me, deposes and says:

- (1) That my name is Johnnie Rodriguez and that I own the real property described below.
- (2) That said real property is subject to an EDWARDS AQUIFER PROTECTION PLAN which was required under the 30 Texas Administrative Code (TAC) Chapter 213.
- (3) That the EDWARDS AQUIFER PROTECTION PLAN for said real property was approved by the Texas Commission on Environmental Quality (TCEQ) on _____.

A copy of the letter of approval from the TCEQ is attached to this affidavit as Exhibit A and is incorporated herein by reference.

- (4) The said real property is located in Comal County, Texas, and the legal description of the property is as follows:

Highpoint 3, Block 1, Lot 1 LGPT ID: 30881
A-155 SUR-35 A P FUQUAY ID: 150222

[Signature]
LANDOWNER-AFFIANT

SWORN AND SUBSCRIBED TO before me, on this 6 day of Oct, 2022

[Signature]
NOTARY PUBLIC

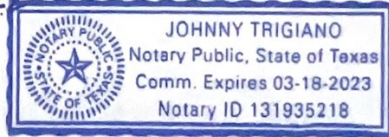

THE STATE OF Texas §

County of Comal §

BEFORE ME, the undersigned authority, on this day personally appeared Johnnie Rodriguez known to me to be the person whose name is subscribed to the foregoing instrument, and acknowledged to me that (s)he executed same for the purpose and consideration therein expressed.

GIVEN under my hand and seal of office on this 6 day of Oct, 2022

[Signature]
NOTARY PUBLIC
Johnny Trigiano
Typed or Printed Name of Notary

MY COMMISSION EXPIRES: 3-18-23

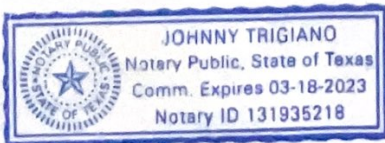



Section 9

Comal Iron and Metals – Application Fee Form (TCEQ-0574)

Application Fee Form

Texas Commission on Environmental Quality

Name of Proposed Regulated Entity: Comal Iron and Metals
 Regulated Entity Location: 1431 FM 306, New Braunfels, Texas 78132
 Name of Customer: Comal Iron and Metals
 Contact Person: Adriana Lee Phone: 512-244-3631
 Customer Reference Number (if issued): CN 600530208
 Regulated Entity Reference Number (if issued): RN 103219572

Austin Regional Office (3373)

Hays Travis Williamson

San Antonio Regional Office (3362)

Bexar Medina Uvalde
 Comal Kinney

Application fees must be paid by check, certified check, or money order, payable to the **Texas Commission on Environmental Quality**. Your canceled check will serve as your receipt. **This form must be submitted with your fee payment.** This payment is being submitted to:

Austin Regional Office San Antonio Regional Office
 Mailed to: TCEQ - Cashier Overnight Delivery to: TCEQ - Cashier
 Revenues Section 12100 Park 35 Circle
 Mail Code 214 Building A, 3rd Floor
 P.O. Box 13088 Austin, TX 78753
 Austin, TX 78711-3088 (512)239-0357

Site Location (Check All That Apply):

Recharge Zone Contributing Zone Transition Zone

Type of Plan	Size	Fee Due
Water Pollution Abatement Plan, Contributing Zone Plan: One Single Family Residential Dwelling	Acres	\$
Water Pollution Abatement Plan, Contributing Zone Plan: Multiple Single Family Residential and Parks	Acres	\$
Water Pollution Abatement Plan, Contributing Zone Plan: Non-residential	4.3 Acres	\$ 4,000
Sewage Collection System	L.F.	\$
Lift Stations without sewer lines	Acres	\$
Underground or Aboveground Storage Tank Facility	3 Tanks	\$ 1,950
Piping System(s)(only)	Each	\$
Exception	Each	\$
Extension of Time	Each	\$

Signature: AL Lee

Date: 10/11/2022

Application Fee Schedule

Texas Commission on Environmental Quality

Edwards Aquifer Protection Program 30 TAC Chapter 213 (effective 05/01/2008)

Water Pollution Abatement Plans and Modifications

Contributing Zone Plans and Modifications

<i>Project</i>	<i>Project Area in Acres</i>	<i>Fee</i>
One Single Family Residential Dwelling	< 5	\$650
Multiple Single Family Residential and Parks	< 5	\$1,500
	5 < 10	\$3,000
	10 < 40	\$4,000
	40 < 100	\$6,500
	100 < 500	\$8,000
	≥ 500	\$10,000
Non-residential (Commercial, industrial, institutional, multi-family residential, schools, and other sites where regulated activities will occur)	< 1	\$3,000
	1 < 5	\$4,000
	5 < 10	\$5,000
	10 < 40	\$6,500
	40 < 100	\$8,000
	≥ 100	\$10,000

Organized Sewage Collection Systems and Modifications

<i>Project</i>	<i>Cost per Linear Foot</i>	<i>Minimum Fee- Maximum Fee</i>
Sewage Collection Systems	\$0.50	\$650 - \$6,500

Underground and Aboveground Storage Tank System Facility Plans and Modifications

<i>Project</i>	<i>Cost per Tank or Piping System</i>	<i>Minimum Fee- Maximum Fee</i>
Underground and Aboveground Storage Tank Facility	\$650	\$650 - \$6,500

Exception Requests

<i>Project</i>	<i>Fee</i>
Exception Request	\$500

Extension of Time Requests

<i>Project</i>	<i>Fee</i>
Extension of Time Request	\$150

Your transaction is complete. Thank you for using TCEQ ePay.

Note: It may take up to 3 working days for this electronic payment to be processed and be reflected in the TCEQ ePay system. Print this receipt and the vouchers for your records. An email receipt has also been sent.

Transaction Information

Trace Number: 582EA000510343
Date: 10/25/2022 02:01 AM
Payment Method: CC - Authorization 000004187G
ePay Actor: ADRIANA LEE
Actor Email: alee@jamesenvironmental.com
IP: 75.109.210.132
TCEQ Amount: \$5,950.00
Texas.gov Price: \$6,084.13*

* This service is provided by Texas.gov, the official website of Texas. The price of this service includes funds that support the ongoing operations and enhancements of Texas.gov, which is provided by a third party in partnership with the State.

Payment Contact Information

Name: ADRIANA LEE
Company: COMAL IRON AND METALS
Address: 1431 FM 306, NEW BRAUNFELS, TX 78132
Phone: 512-244-3631

Cart Items

Click on the voucher number to see the voucher details.

Voucher	Fee Description	AR Number	Amount
598148	EDWARDS AQUIFER APPLICATION FEE-SAN ANTONIO REGION		\$5,950.00
		TCEQ Amount:	\$5,950.00

[ePay Again](#)

[Exit ePay](#)

Note: It may take up to 3 working days for this electronic payment to be processed and be reflected in the TCEQ ePay system. Print this receipt for your records.



Section 10

Comal Iron and Metals – Core Data Form (TCEQ-10400)

TCEQ Core Data Form

TCEQ Use Only

For detailed instructions regarding completion of this form, please read the Core Data Form Instructions or call 512-239-5175.

SECTION I: General Information

1. Reason for Submission (If other is checked please describe in space provided.)		
<input checked="" type="checkbox"/> New Permit, Registration or Authorization (Core Data Form should be submitted with the program application.)		
<input type="checkbox"/> Renewal (Core Data Form should be submitted with the renewal form)	<input type="checkbox"/> Other Update RE Name	
2. Customer Reference Number (if issued)	Follow this link to search for CN or RN numbers in Central Registry**	3. Regulated Entity Reference Number (if issued)
CN 600530208		RN 103219572

SECTION II: Customer Information

4. General Customer Information	5. Effective Date for Customer Information Updates (mm/dd/yyyy)	03/29/2023	
<input type="checkbox"/> New Customer <input checked="" type="checkbox"/> Update to Customer Information <input type="checkbox"/> Change in Regulated Entity Ownership <input type="checkbox"/> Change in Legal Name (Verifiable with the Texas Secretary of State or Texas Comptroller of Public Accounts)			
The Customer Name submitted here may be updated automatically based on what is current and active with the Texas Secretary of State (SOS) or Texas Comptroller of Public Accounts (CPA).			
6. Customer Legal Name (If an individual, print last name first: eg: Doe, John)		If new Customer, enter previous Customer below:	
COMAL IRON & METAL INC			
7. TX SOS/CPA Filing Number	8. TX State Tax ID (11 digits)	9. Federal Tax ID (9 digits)	10. DUNS Number (if applicable)
0110832000	3-20089-366-7	74-2537151	
11. Type of Customer:	<input checked="" type="checkbox"/> Corporation <input type="checkbox"/> Individual	Partnership: <input type="checkbox"/> General <input type="checkbox"/> Limited	
Government: <input type="checkbox"/> City <input type="checkbox"/> County <input type="checkbox"/> Federal <input type="checkbox"/> State <input type="checkbox"/> Other		<input type="checkbox"/> Sole Proprietorship	<input type="checkbox"/> Other:
12. Number of Employees		13. Independently Owned and Operated?	
<input type="checkbox"/> 0-20 <input checked="" type="checkbox"/> 21-100 <input type="checkbox"/> 101-250 <input type="checkbox"/> 251-500 <input type="checkbox"/> 501 and higher		<input checked="" type="checkbox"/> Yes <input type="checkbox"/> No	
14. Customer Role (Proposed or Actual) – as it relates to the Regulated Entity listed on this form. Please check one of the following			
<input type="checkbox"/> Owner <input type="checkbox"/> Operator <input checked="" type="checkbox"/> Owner & Operator <input type="checkbox"/> Occupational Licensee <input type="checkbox"/> Responsible Party <input type="checkbox"/> Voluntary Cleanup Applicant <input type="checkbox"/> Other:			
15. Mailing Address:	1431 FM 306		
	City	NEW BRAUNFELS	State TX ZIP 78132 ZIP + 4 4270
16. Country Mailing Information (if outside USA)		17. E-Mail Address (if applicable)	
		comalironjohnnie@mac.com	
18. Telephone Number	19. Extension or Code	20. Fax Number (if applicable)	
(830) 625-4920		() -	

SECTION III: Regulated Entity Information

21. General Regulated Entity Information (If 'New Regulated Entity' is selected below this form should be accompanied by a permit application)	
<input type="checkbox"/> New Regulated Entity <input type="checkbox"/> Update to Regulated Entity Name <input checked="" type="checkbox"/> Update to Regulated Entity Information	
The Regulated Entity Name submitted may be updated in order to meet TCEQ Agency Data Standards (removal of organizational endings such as Inc, LP, or LLC).	
22. Regulated Entity Name (Enter name of the site where the regulated action is taking place.)	
COMAL IRON & METAL INC	

23. Street Address of the Regulated Entity: <i>(No PO Boxes)</i>	1431 FM 306							
	City	NEW BRAUNFELS	State	TX	ZIP	78132	ZIP + 4	4270
24. County	COMAL							

Enter Physical Location Description if no street address is provided.

25. Description to Physical Location:								
26. Nearest City						State	Nearest ZIP Code	
27. Latitude (N) In Decimal:	29.745933			28. Longitude (W) In Decimal:	-96.101869			
Degrees	Minutes	Seconds	Degrees	Minutes	Seconds			
29. Primary SIC Code (4 digits)	30. Secondary SIC Code (4 digits)		31. Primary NAICS Code (5 or 6 digits)		32. Secondary NAICS Code (5 or 6 digits)			
5093								
33. What is the Primary Business of this entity? <i>(Do not repeat the SIC or NAICS description.)</i>								
Recyclable Material Merchant Wholesalers.								
34. Mailing Address:	1431 FM 306							
	City	NEW BRAUNFELS	State	TX	ZIP	78132	ZIP + 4	4270
35. E-Mail Address:	safety@comalironandmetals.com							
36. Telephone Number	37. Extension or Code		38. Fax Number <i>(if applicable)</i>					
(830) 625-4920			() -					

39. TCEQ Programs and ID Numbers Check all Programs and write in the permits/registration numbers that will be affected by the updates submitted on this form. See the Core Data Form instructions for additional guidance.

<input type="checkbox"/> Dam Safety	<input type="checkbox"/> Districts	<input checked="" type="checkbox"/> Edwards Aquifer	<input type="checkbox"/> Emissions Inventory Air	<input type="checkbox"/> Industrial Hazardous Waste
		Application Pending		
<input type="checkbox"/> Municipal Solid Waste	<input type="checkbox"/> New Source Review Air	<input type="checkbox"/> OSSF	<input type="checkbox"/> Petroleum Storage Tank	<input type="checkbox"/> PWS
<input type="checkbox"/> Sludge	<input checked="" type="checkbox"/> Storm Water	<input type="checkbox"/> Title V Air	<input type="checkbox"/> Tires	<input type="checkbox"/> Used Oil
	TXR05DJ84- Pending EAPP Approval			
<input type="checkbox"/> Voluntary Cleanup	<input type="checkbox"/> Waste Water	<input type="checkbox"/> Wastewater Agriculture	<input type="checkbox"/> Water Rights	<input type="checkbox"/> Other:

SECTION IV: Preparer Information

40. Name:	Mahdi Al-Sallami	41. Title:	Environmental Specialist
42. Telephone Number	43. Ext./Code	44. Fax Number	45. E-Mail Address
(512) 244-3631		() -	info@jamesenvironmental.com

SECTION V: Authorized Signature

46. By my signature below, I certify, to the best of my knowledge, that the information provided in this form is true and complete, and that I have signature authority to submit this form on behalf of the entity specified in Section II, Field 6 and/or as required for the updates to the ID numbers identified in field 39.

Company:	COMAL IRON & METAL INC	Job Title:	Owner
Name (In Print):	Johnnie Rodriguez Jr.	Phone:	(830) 625- 4920
Signature:		Date:	March 30, 2023