

WATER POLLUTION ABATEMENT PLAN

For:

**Ivy Kids of Stone Oak
Wilderness Oak,
San Antonio, Texas 78258**

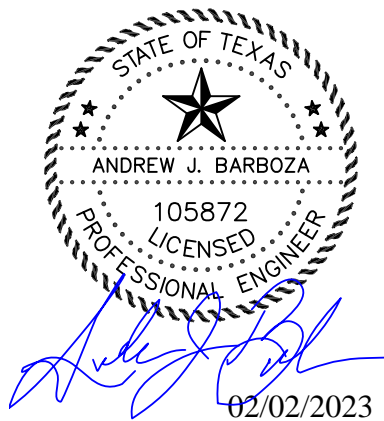

PREPARED BY: Jackson Chapman

REVIEWED BY: Andrew J. Barboza, P.E.

K Love
ENGINEERING
Site Development Engineering Services
Firm #11042

February 2, 2023

TABLE OF CONTENTS

EDWARDS AQUIFER APPLICATION COVER.....	SECTION 1
EDWARDS AQUIFER APPLICATION COVER.....	TCEQ-20705
GENERAL INFORMATION	SECTION 2
GENERAL INFORMATION FORM.....	TCEQ-0587
<i>Road Map.....</i>	<i>Attachment A</i>
<i>USGS/Edwards Recharge Zone Map.....</i>	<i>Attachment B</i>
<i>Project Description.....</i>	<i>Attachment C</i>
GEOLOGIC ASSESSMENT	SECTION 3
GEOLOGIC ASSESSMENT FORM.....	TCEQ-0585
<i>Geologic Assessment Table.....</i>	<i>Attachment A</i>
<i>Stratigraphic Column.....</i>	<i>Attachment B</i>
<i>Site Geology.....</i>	<i>Attachment C</i>
<i>Site Geologic Map.....</i>	<i>Attachment D</i>
<i>Geologic Assessment Letter.....</i>	
WATER POLLUTION ABATEMENT PLAN.....	SECTION 4
WATER POLLUTION ABATEMENT PLAN APPLICATION.....	TCEQ-0584
<i>Factors Affecting Water Quality.....</i>	<i>Attachment A</i>
<i>Volume and Character of Storm Water.....</i>	<i>Attachment B</i>
<i>Suitability Letter from Authorized Agent.....</i>	<i>Attachment C</i>
<i>Exception to the Required Geologic Assessment.....</i>	<i>Attachment D</i>
<i>WPAP Site Plan.....</i>	<i>Exhibit EX-1A</i>
TEMPORARY STORMWATER	SECTION 5
TEMPORARY STORMWATER SECTION.....	TCEQ-0602
<i>Spill Response Actions.....</i>	<i>Attachment A</i>
<i>Potential Sources of Contamination.....</i>	<i>Attachment B</i>
<i>Sequence of Major Activities.....</i>	<i>Attachment C</i>
<i>Temporary Best Management Practices and Measures.....</i>	<i>Attachment D</i>
<i>Request to Temporarily Seal a Feature.....</i>	<i>Attachment E</i>
<i>Structural Practices.....</i>	<i>Attachment F</i>
<i>Drainage Area Map.....</i>	<i>Attachment G</i>
<i>Existing Drainage Area Map.....</i>	<i>Exhibit EX-2A</i>
<i>Proposed Drainage Area Map.....</i>	<i>Exhibit EX-2B</i>
<i>Temporary Sediment Pond(s) Plans and Calculations.....</i>	<i>Attachment H</i>
<i>Inspection and Maintenance for BMPs.....</i>	<i>Attachment I</i>
<i>Schedule of Interim and Permanent Soil Stabilization Practices.....</i>	<i>Attachment J</i>
PERMANENT STORMWATER	SECTION 6
PERMANENT STORMWATER SECTION.....	TCEQ-0600
<i>20% or Less Impervious Cover Waiver.....</i>	<i>Attachment A</i>
<i>BMPs for Upgradient Stormwater.....</i>	<i>Attachment B</i>

<i>BMPs for On-site Stormwater</i>	<i>Attachment C</i>
<i>Technical Abstract Up-Flo Filter CPZ – TCEQ Sizing</i>	<i>Attachment C-1</i>
<i>BMPs for Surface Streams</i>	<i>Attachment D</i>
<i>Request to Seal a Feature</i>	<i>Attachment E</i>
<i>Construction Plans</i>	<i>Attachment F</i>
<i>Storm Drain Plan</i>	<i>Exhibit EX-3A</i>
<i>Water Quality Plan</i>	<i>Exhibit EX-3B</i>
<i>Water Quality Details</i>	<i>Exhibit EX-3C</i>
<i>Inspection, Maintenance, Repair and Retrofit Plan</i>	<i>Attachment G</i>
<i>Pilot-Scale Field Testing Plan</i>	<i>Attachment H</i>
<i>Measures for Minimizing Surface Stream Contamination</i>	<i>Attachment I</i>
ADDITIONAL FORMS	SECTION 7
AGENT AUTHORIZATION FORM.....	TCEQ-0599
APPLICATION FEE FORM.....	TCEQ-0574
<i>Check Payable to the “Texas Commission on Environmental Quality”</i>	
CORE DATA FORM.....	TCEQ-10400

SECTION 1

EDWARDS AQUIFER APPLICATION COVER

Texas Commission on Environmental Quality

Edwards Aquifer Application Cover Page

Our Review of Your Application

The Edwards Aquifer Program staff conducts an administrative and technical review of all applications. The turnaround time for administrative review can be up to 30 days as outlined in 30 TAC 213.4(e). Generally administrative completeness is determined during the intake meeting or within a few days of receipt. The turnaround time for technical review of an administratively complete Edwards Aquifer application is 90 days as outlined in 30 TAC 213.4(e). Please know that the review and approval time is directly impacted by the quality and completeness of the initial application that is received. In order to conduct a timely review, it is imperative that the information provided in an Edwards Aquifer application include final plans, be accurate, complete, and in compliance with [30 TAC 213](#).

Administrative Review

1. [Edwards Aquifer applications](#) must be deemed administratively complete before a technical review can begin. To be considered administratively complete, the application must contain completed forms and attachments, provide the requested information, and meet all the site plan requirements. The submitted application and plan sheets should be final plans. Please submit one full-size set of plan sheets with the original application, and half-size sets with the additional copies.

To ensure that all applicable documents are included in the application, the program has developed tools to guide you and web pages to provide all forms, checklists, and guidance. Please visit the below website for assistance: <http://www.tceq.texas.gov/field/eapp>.

2. This Edwards Aquifer Application Cover Page form (certified by the applicant or agent) must be included in the application and brought to the administrative review meeting.
3. Administrative reviews are scheduled with program staff who will conduct the review. Applicants or their authorized agent should call the appropriate regional office, according to the county in which the project is located, to schedule a review. The average meeting time is one hour.
4. In the meeting, the application is examined for administrative completeness. Deficiencies will be noted by staff and emailed or faxed to the applicant and authorized agent at the end of the meeting, or shortly after. Administrative deficiencies will cause the application to be deemed incomplete and returned.

An appointment should be made to resubmit the application. The application is re-examined to ensure all deficiencies are resolved. The application will only be deemed administratively complete when all administrative deficiencies are addressed.

5. If an application is received by mail, courier service, or otherwise submitted without a review meeting, the administrative review will be conducted within 30 days. The applicant and agent will be contacted with the results of the administrative review. If the application is found to be administratively incomplete, it can be retrieved from the regional office or returned by regular mail. If returned by mail, the regional office may require arrangements for return shipping.
6. If the geologic assessment was completed before October 1, 2004 and the site contains “possibly sensitive” features, the assessment must be updated in accordance with the *Instructions to Geologists* (TCEQ-0585 Instructions).

Technical Review

1. When an application is deemed administratively complete, the technical review period begins. The regional office will distribute copies of the application to the identified affected city, county, and groundwater conservation district whose jurisdiction includes the subject site. These entities and the public have 30 days to provide comments on the application to the regional office. All comments received are reviewed by TCEQ.
2. A site assessment is usually conducted as part of the technical review, to evaluate the geologic assessment and observe existing site conditions. The site must be accessible to our staff. The site boundaries should be

clearly marked, features identified in the geologic assessment should be flagged, roadways marked and the alignment of the Sewage Collection System and manholes should be staked at the time the application is submitted. If the site is not marked the application may be returned.

3. We evaluate the application for technical completeness and contact the applicant and agent via Notice of Deficiency (NOD) to request additional information and identify technical deficiencies. There are two deficiency response periods available to the applicant. There are 14 days to resolve deficiencies noted in the first NOD. If a second NOD is issued, there is an additional 14 days to resolve deficiencies. If the response to the second notice is not received, is incomplete or inadequate, or provides new information that is incomplete or inadequate, the application must be withdrawn or will be denied. Please note that because the technical review is underway, whether the application is withdrawn or denied **the application fee will be forfeited**.
4. The program has 90 calendar days to complete the technical review of the application. If the application is technically adequate, such that it complies with the Edwards Aquifer rules, and is protective of the Edwards Aquifer during and after construction, an approval letter will be issued. Construction or other regulated activity may not begin until an approval is issued.

Mid-Review Modifications

It is important to have final site plans prior to beginning the permitting process with TCEQ to avoid delays.

Occasionally, circumstances arise where you may have significant design and/or site plan changes after your Edwards Aquifer application has been deemed administratively complete by TCEQ. This is considered a “Mid-Review Modification”. Mid-Review Modifications may require redistribution of an application that includes the proposed modifications for public comment.

If you are proposing a Mid-Review Modification, two options are available:

- If the technical review has begun your application can be denied/withdrawn, your fees will be forfeited, and the plan will have to be resubmitted.
- TCEQ can continue the technical review of the application as it was submitted, and a modification application can be submitted at a later time.

If the application is denied/withdrawn, the resubmitted application will be subject to the administrative and technical review processes and will be treated as a new application. The application will be redistributed to the affected jurisdictions.

Please contact the regional office if you have questions. If your project is located in Williamson, Travis, or Hays County, contact TCEQ’s Austin Regional Office at 512-339-2929. If your project is in Comal, Bexar, Medina, Uvalde, or Kinney County, contact TCEQ’s San Antonio Regional Office at 210-490-3096

Please fill out all required fields below and submit with your application.

1. Regulated Entity Name: Ivy Kids of Stone Oak					2. Regulated Entity No.:				
3. Customer Name: AZEA Holdings, LLC					4. Customer No.:				
5. Project Type: (Please circle/check one)	<input checked="" type="radio"/> New	Modification			Extension		Exception		
6. Plan Type: (Please circle/check one)	<input checked="" type="radio"/> WPAP	<input type="radio"/> CZP	<input type="radio"/> SCS	<input type="radio"/> UST	<input type="radio"/> AST	<input type="radio"/> EXP	<input type="radio"/> EXT	Technical Clarification	Optional Enhanced Measures
7. Land Use: (Please circle/check one)	<input type="radio"/> Residential		<input checked="" type="radio"/> Non-residential			8. Site (acres):		2.757 Acres	
9. Application Fee:	\$4,000.00		10. Permanent BMP(s):			Stormwater Filter (Up-Flo)			
11. SCS (Linear Ft.):			12. AST/UST (No. Tanks):						
13. County:	Bexar		14. Watershed:			Salado Creek Watershed			

Application Distribution

Instructions: Use the table below to determine the number of applications required. One original and one copy of the application, plus additional copies (as needed) for each affected incorporated city, county, and groundwater conservation district are required. Linear projects or large projects, which cross into multiple jurisdictions, can require additional copies. Refer to the “Texas Groundwater Conservation Districts within the EAPP Boundaries” map found at:

http://www.tceq.texas.gov/assets/public/compliance/field_ops/eapp/EAPP%20GWCD%20map.pdf

For more detailed boundaries, please contact the conservation district directly.

Austin Region			
County:	Hays	Travis	Williamson
Original (1 req.)	—	—	—
Region (1 req.)	—	—	—
County(ies)	—	—	—
Groundwater Conservation District(s)	<input type="checkbox"/> Edwards Aquifer Authority <input type="checkbox"/> Barton Springs/ Edwards Aquifer <input type="checkbox"/> Hays Trinity <input type="checkbox"/> Plum Creek	<input type="checkbox"/> Barton Springs/ Edwards Aquifer	NA
City(ies) Jurisdiction	<input type="checkbox"/> Austin <input type="checkbox"/> Buda <input type="checkbox"/> Dripping Springs <input type="checkbox"/> Kyle <input type="checkbox"/> Mountain City <input type="checkbox"/> San Marcos <input type="checkbox"/> Wimberley <input type="checkbox"/> Woodcreek	<input type="checkbox"/> Austin <input type="checkbox"/> Bee Cave <input type="checkbox"/> Pflugerville <input type="checkbox"/> Rollingwood <input type="checkbox"/> Round Rock <input type="checkbox"/> Sunset Valley <input type="checkbox"/> West Lake Hills	<input type="checkbox"/> Austin <input type="checkbox"/> Cedar Park <input type="checkbox"/> Florence <input type="checkbox"/> Georgetown <input type="checkbox"/> Jerrell <input type="checkbox"/> Leander <input type="checkbox"/> Liberty Hill <input type="checkbox"/> Pflugerville <input type="checkbox"/> Round Rock

San Antonio Region					
County:	Bexar	Comal	Kinney	Medina	Uvalde
Original (1 req.)	<u>X</u>	—	—	—	—
Region (1 req.)	<u>X</u>	—	—	—	—
County(ies)	<u>X</u>	—	—	—	—
Groundwater Conservation District(s)	<input checked="" type="checkbox"/> Edwards Aquifer Authority <input checked="" type="checkbox"/> Trinity-Glen Rose	<input type="checkbox"/> Edwards Aquifer Authority	<input type="checkbox"/> Kinney	<input type="checkbox"/> EAA <input type="checkbox"/> Medina	<input type="checkbox"/> EAA <input type="checkbox"/> Uvalde
City(ies) Jurisdiction	<input type="checkbox"/> Castle Hills <input type="checkbox"/> Fair Oaks Ranch <input type="checkbox"/> Helotes <input type="checkbox"/> Hill Country Village <input type="checkbox"/> Hollywood Park <input checked="" type="checkbox"/> San Antonio (SAWS) <input type="checkbox"/> Shavano Park	<input type="checkbox"/> Bulverde <input type="checkbox"/> Fair Oaks Ranch <input type="checkbox"/> Garden Ridge <input type="checkbox"/> New Braunfels <input type="checkbox"/> Schertz	NA	<input type="checkbox"/> San Antonio ETJ (SAWS)	NA

I certify that to the best of my knowledge, that the application is complete and accurate. This application is hereby submitted to TCEQ for administrative review and technical review.

Andrew J. Barboza

Print Name of Customer/Authorized Agent

12/19/2022

Signature of Customer/Authorized Agent

Date

FOR TCEQ INTERNAL USE ONLY			
Date(s) Reviewed:		Date Administratively Complete:	
Received From:		Correct Number of Copies:	
Received By:		Distribution Date:	
EAPP File Number:		Complex:	
Admin. Review(s) (No.):		No. AR Rounds:	
Delinquent Fees (Y/N):		Review Time Spent:	
Lat./Long. Verified:		SOS Customer Verification:	
Agent Authorization Complete/Notarized (Y/N):		Fee Check:	Payable to TCEQ (Y/N):
Core Data Form Complete (Y/N):			Signed (Y/N):
Core Data Form Incomplete Nos.:			Less than 90 days old (Y/N):

SECTION 2

GENERAL INFORMATION

General Information Form

Texas Commission on Environmental Quality

For Regulated Activities on the Edwards Aquifer Recharge and Transition Zones and Relating to 30 TAC §213.4(b) & §213.5(b)(2)(A), (B) Effective June 1, 1999

To ensure that the application is administratively complete, confirm that all fields in the form are complete, verify that all requested information is provided, consistently reference the same site and contact person in all forms in the application, and ensure forms are signed by the appropriate party.

Note: Including all the information requested in the form and attachments contributes to more streamlined technical reviews.

Signature

To the best of my knowledge, the responses to this form accurately reflect all information requested concerning the proposed regulated activities and methods to protect the Edwards Aquifer. This **General Information Form** is hereby submitted for TCEQ review. The application was prepared by:

Print Name of Customer/Agent: Andrew J. Barboza, P.E.

Date: 02/14/2023

Signature of Customer/Agent:



Project Information

1. Regulated Entity Name: Ivy Kids of Stone Oak
2. County: Bexar
3. Stream Basin: Mustang Creek
4. Groundwater Conservation District (If applicable): n/a
5. Edwards Aquifer Zone:
 Recharge Zone
 Transition Zone
6. Plan Type:
 WPAP
 SCS
 Modification
 AST
 UST
 Exception Request

7. Customer (Applicant):

Contact Person: Mr. Shehmir Sherali
Entity: Azea Holdings, LLC
Mailing Address: 11010 Coachlight St., Ste 101
City, State: San Antonio, TX Zip: 78216
Telephone: (210) 824-3892 FAX: N/A
Email Address: shehmir@petroleumdist.com

8. Agent/Representative (If any):

Contact Person: Andrew J. Barboza, P.E.
Entity: KLove Engineering, LLC
Mailing Address: 22610 US Highway 281 N. Ste. 204
City, State: San Antonio, TX Zip: 78258
Telephone: (210) 485-5683 FAX: N/A
Email Address: klove@kloveengineering.com

9. Project Location:

- The project site is located inside the city limits of _____.
- The project site is located outside the city limits but inside the ETJ (extra-territorial jurisdiction) of San Antonio.
- The project site is not located within any city's limits or ETJ.

10. The location of the project site is described below. The description provides sufficient detail and clarity so that the TCEQ's Regional staff can easily locate the project and site boundaries for a field investigation.

Approximately 0.13 miles southwest of Wilderness Oak and Canyon Golf Road intersection.

11. **Attachment A – Road Map.** A road map showing directions to and the location of the project site is attached. The project location and site boundaries are clearly shown on the map.

12. **Attachment B - USGS / Edwards Recharge Zone Map.** A copy of the official 7 ½ minute USGS Quadrangle Map (Scale: 1" = 2000') of the Edwards Recharge Zone is attached. The map(s) clearly show:

- Project site boundaries.
- USGS Quadrangle Name(s).
- Boundaries of the Recharge Zone (and Transition Zone, if applicable).
- Drainage path from the project site to the boundary of the Recharge Zone.

13. **The TCEQ must be able to inspect the project site or the application will be returned.** Sufficient survey staking is provided on the project to allow TCEQ regional staff to locate the boundaries and alignment of the regulated activities and the geologic or manmade features noted in the Geologic Assessment.

Survey staking will be completed by this date: _____

14. **Attachment C – Project Description.** Attached at the end of this form is a detailed narrative description of the proposed project. The project description is consistent throughout the application and contains, at a minimum, the following details:

- Area of the site
- Offsite areas
- Impervious cover
- Permanent BMP(s)
- Proposed site use
- Site history
- Previous development
- Area(s) to be demolished

15. Existing project site conditions are noted below:

- Existing commercial site
- Existing industrial site
- Existing residential site
- Existing paved and/or unpaved roads
- Undeveloped (Cleared)
- Undeveloped (Undisturbed/Uncleared)
- Other: _____

Prohibited Activities

16. I am aware that the following activities are prohibited on the Recharge Zone and are not proposed for this project:

- (1) Waste disposal wells regulated under 30 TAC Chapter 331 of this title (relating to Underground Injection Control);
- (2) New feedlot/concentrated animal feeding operations, as defined in 30 TAC §213.3;
- (3) Land disposal of Class I wastes, as defined in 30 TAC §335.1;
- (4) The use of sewage holding tanks as parts of organized collection systems; and
- (5) New municipal solid waste landfill facilities required to meet and comply with Type I standards which are defined in §330.41(b), (c), and (d) of this title (relating to Types of Municipal Solid Waste Facilities).
- (6) New municipal and industrial wastewater discharges into or adjacent to water in the state that would create additional pollutant loading.

17. I am aware that the following activities are prohibited on the Transition Zone and are not proposed for this project:

- (1) Waste disposal wells regulated under 30 TAC Chapter 331 (relating to Underground Injection Control);

- (2) Land disposal of Class I wastes, as defined in 30 TAC §335.1; and
- (3) New municipal solid waste landfill facilities required to meet and comply with Type I standards which are defined in §330.41 (b), (c), and (d) of this title.

Administrative Information

18. The fee for the plan(s) is based on:

- For a Water Pollution Abatement Plan or Modification, the total acreage of the site where regulated activities will occur.
- For an Organized Sewage Collection System Plan or Modification, the total linear footage of all collection system lines.
- For a UST Facility Plan or Modification or an AST Facility Plan or Modification, the total number of tanks or piping systems.
- A request for an exception to any substantive portion of the regulations related to the protection of water quality.
- A request for an extension to a previously approved plan.

19. Application fees are due and payable at the time the application is filed. If the correct fee is not submitted, the TCEQ is not required to consider the application until the correct fee is submitted. Both the fee and the Edwards Aquifer Fee Form have been sent to the Commission's:

- TCEQ cashier
- Austin Regional Office (for projects in Hays, Travis, and Williamson Counties)
- San Antonio Regional Office (for projects in Bexar, Comal, Kinney, Medina, and Uvalde Counties)

20. Submit one (1) original and one (1) copy of the application, plus additional copies as needed for each affected incorporated city, groundwater conservation district, and county in which the project will be located. The TCEQ will distribute the additional copies to these jurisdictions. The copies must be submitted to the appropriate regional office.

21. No person shall commence any regulated activity until the Edwards Aquifer Protection Plan(s) for the activity has been filed with and approved by the Executive Director.



PROJECT NO. 1393-00

DATE: 10/04/2022

DRAWN BY: AJB DESIGNED BY: AJB

SCALE: N.T.S.

IVY KIDS OF STONE OAK

24278 WILDERNESS OAK
SAN ANTONIO, TEXAS

ROAD MAP

Klove
ENGINEERING
Site Development Engineering Services
Firm No. 11042
www.kloveengineering.com (210) 485-5683

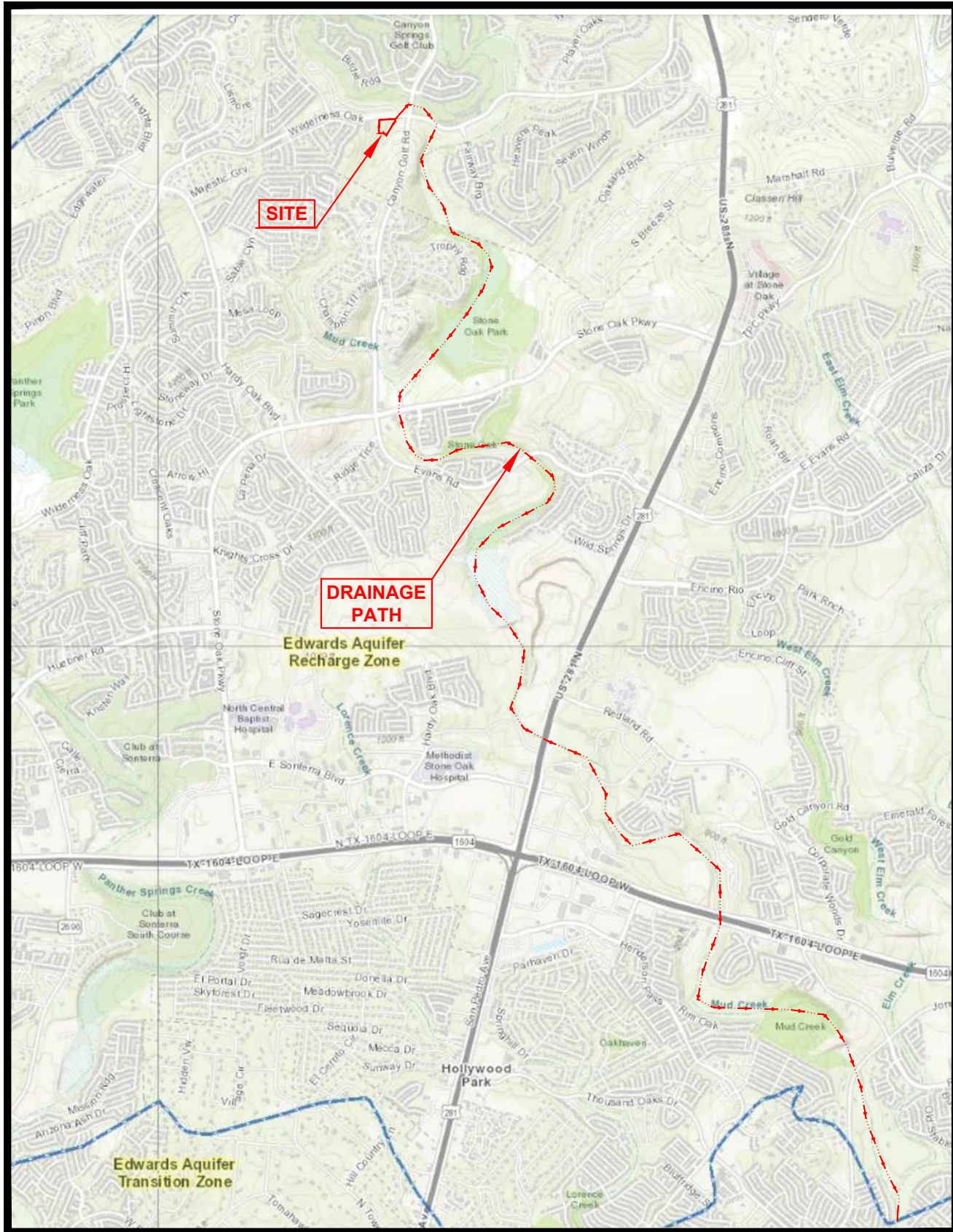

PROJECT NO. 1393-00
 DATE: 10/04/2022
 DRAWN BY: AJB DESIGNED BY: AJB
 SCALE: N.T.S.

IVY KIDS OF STONE OAK
 24278 WILDERNESS OAK
 SAN ANTONIO, TEXAS
 USGS MAP

Klove
ENGINEERING
 Site Development Engineering Services
 Firm No. 11042
 www.kloveengineering.com (210) 485-5683

GENERAL INFORMATION SECTION

ATTACHMENT C

Project Description

The subject project is located approximately 0.13 miles southwest of Wilderness Oak and Canyon Golf Road intersection in San Antonio, TX. This location is within the limits of the City of San Antonio ETJ and the Steven M. Clouse Water Recycling Center. This area is not within a mandatory detention area and is currently undeveloped. The property is not located within the 100-yr floodplain per the Flood Emergency Management Agency (FEMA) Flood Insurance Rate Map (FIRM) #48029C014G, dated September 29, 2010.

The proposed day care facility and retail buildings will be constructed on Lot 2 (2.757 acres) out of the subdivision plat "*Bee Clean #9*", Plat No. 20-11800128. The total proposed impervious cover for this proposed development is approximately 1.707 acres (74,365 sq-ft). The proposed improvements addressed by this Water Pollution Abatement Plan (WPAP) are as follows:

- (1) Access Drive to existing driveway
- (2) Sidewalk
- (3) Parking Lot
- (4) Commercial Building
- (5) Utilities

To prevent pollution of storm water runoff originating on-site and potentially flowing across and off the site after construction, an Up-Flo Filter (Hydraflow International) is proposed to be built on the southeast side of the property as a permanent BMP. The Permanent Pollution Abatement Measures (BMPs) for Ivy Kids of Stone Oak will be designed in accordance with the TCEQ Technical Guidance Manual RG-348 (Revised September 2007) to remove 78% of the increased Total Suspended Solids (TSS) for the proposed improvements.

Potable water and wastewater disposal is provided by the San Antonio Water System (SAWS). Wastewater is disposed of by conveyance to the existing Steven M. Clouse Water Recycling Center operated by SAWS.

SECTION 3

GEOLOGIC ASSESMENT

Geologic Assessment

Texas Commission on Environmental Quality

For Regulated Activities on The Edwards Aquifer Recharge/transition Zones and Relating to 30 TAC §213.5(b)(3), Effective June 1, 1999

To ensure that the application is administratively complete, confirm that all fields in the form are complete, verify that all requested information is provided, consistently reference the same site and contact person in all forms in the application, and ensure forms are signed by the appropriate party.

Note: Including all the information requested in the form and attachments contributes to more streamlined technical reviews.

Signature

To the best of my knowledge, the responses to this form accurately reflect all information requested concerning the proposed regulated activities and methods to protect the Edwards Aquifer. My signature certifies that I am qualified as a geologist as defined by 30 TAC Chapter 213.

Print Name of Geologist: Nathan Dunn

Telephone: 830-816-5434

Date: 05/28/2020

Fax: 210-816-5436

Representing: Broadbent & Associates, Inc. TBPG Firm Registration No. 50007 (Name of Company and TBPG or TBPE registration number)

Signature of Geologist:

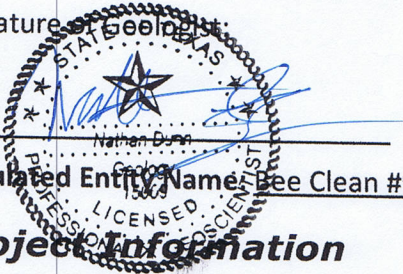

Regulated Entity Name: Bee Clean #9, Wilderness Oak, San Antonio, TX 78258 and Ivy Kids of Stone Oak

Project Information

1. Date(s) Geologic Assessment was performed: 04/10/2020

2. Type of Project:

WPAP

AST

SCS

UST

3. Location of Project:

Recharge Zone

Transition Zone

Contributing Zone within the Transition Zone

4. **Attachment A - Geologic Assessment Table.** Completed Geologic Assessment Table (Form TCEQ-0585-Table) is attached.
5. Soil cover on the project site is summarized in the table below and uses the SCS Hydrologic Soil Groups* (Urban Hydrology for Small Watersheds, Technical Release No. 55, Appendix A, Soil Conservation Service, 1986). If there is more than one soil type on the project site, show each soil type on the site Geologic Map or a separate soils map.

Table 1 - Soil Units, Infiltration Characteristics and Thickness

Soil Name	Group*	Thickness(feet)
Eckrant	D	0 to 7
Rock Outcrop	D	0 to 7

* Soil Group Definitions (Abbreviated)

- A. Soils having a high infiltration rate when thoroughly wetted.
- B. Soils having a moderate infiltration rate when thoroughly wetted.
- C. Soils having a slow infiltration rate when thoroughly wetted.
- D. Soils having a very slow infiltration rate when thoroughly wetted.

6. **Attachment B – Stratigraphic Column.** A stratigraphic column showing formations, members, and thicknesses is attached. The outcropping unit, if present, should be at the top of the stratigraphic column. Otherwise, the uppermost unit should be at the top of the stratigraphic column.
7. **Attachment C – Site Geology.** A narrative description of the site specific geology including any features identified in the Geologic Assessment Table, a discussion of the potential for fluid movement to the Edwards Aquifer, stratigraphy, structure(s), and karst characteristics is attached.
8. **Attachment D – Site Geologic Map(s).** The Site Geologic Map must be the same scale as the applicant's Site Plan. The minimum scale is 1": 400'
 Applicant's Site Plan Scale: 1" = 30'
 Site Geologic Map Scale: 1" = 30'
 Site Soils Map Scale (if more than 1 soil type): 1" = 30'
9. Method of collecting positional data:
 - Global Positioning System (GPS) technology.
 - Other method(s). Please describe method of data collection: _____
10. The project site and boundaries are clearly shown and labeled on the Site Geologic Map.
11. Surface geologic units are shown and labeled on the Site Geologic Map.

12. Geologic or manmade features were discovered on the project site during the field investigation. They are shown and labeled on the Site Geologic Map and are described in the attached Geologic Assessment Table.
- Geologic or manmade features were not discovered on the project site during the field investigation.
13. The Recharge Zone boundary is shown and labeled, if appropriate.
14. All known wells (test holes, water, oil, unplugged, capped and/or abandoned, etc.): If applicable, the information must agree with Item No. 20 of the WPAP Application Section.
- There are _____ (#) wells present on the project site and the locations are shown and labeled. (Check all of the following that apply.)
- The wells are not in use and have been properly abandoned.
- The wells are not in use and will be properly abandoned.
- The wells are in use and comply with 16 TAC Chapter 76.
- There are no wells or test holes of any kind known to exist on the project site.

Administrative Information

15. Submit one (1) original and one (1) copy of the application, plus additional copies as needed for each affected incorporated city, groundwater conservation district, and county in which the project will be located. The TCEQ will distribute the additional copies to these jurisdictions. The copies must be submitted to the appropriate regional office.

GEOLOGIC ASSESSMENT TABLE			PROJECT NAME: Bee Clean #9																
LOCATION			FEATURE CHARACTERISTICS										EVALUATION		PHYSICAL SETTING				
1A	1B*	1C*	2A	2B	3	4			5	5A	6	7	8A	8B	9	10	11		12
FEATURE ID	LATITUDE	LONGITUDE	FEATURE TYPE	POINTS	FORMATION	DIMENSIONS (FEET)			TREND (DEGREES)	DENSITY (NO/FT)	APERTURE (FEET)	INFILL	RELATIVE INFILTRATION RATE	TOTAL	SENSITIVITY		CATCHMENT AREA (ACRES)		TOPOGRAPHY
						X	Y	Z							<40	>40	<1.6	>1.6	
O-1	29.666035°	-98.479271°	O	5	Kk	20	25	1					N,O	5	10	X		X	Streambed
Z-1	29.665882°	-98.479448°	Z	30	Kk	60	5	3					N,O	10	40	X		X	Streambed
O-2	29.665718°	-98.479553°	O	5	Kk	25	50	1					N,O	5	10	X		X	Streambed
O-3	29.665399°	-98.479782°	O	5	Kk	20	15	1					N,O	5	10	X		X	Streambed
Z-2	29.664730°	-98.480236°	Z	30	Kk	5	35	2					N,O	10	40	X		X	Streambed
O-4	29.664485°	-98.480272°	O	5	Kk	25	75	1					N,O	5	10	X		X	Streambed
O-5	29.665049°	-98.481258°	O	5	Kk	15	45	1					N,O	5	10	X		X	Hillside
O-6	29.666001°	-98.481103°	O	5	Kk	10	50	1					N,O	5	10	X		X	Drainage
O-7	29.665086°	-98.480546°	O	5	Kk	20	20	1					N,O	5	10	X		X	Hillside
O-8	29.666171°	-98.480325°	O	5	Kk	5	300	2.5					N,O	5	10	X		X	Hillside
F-1	29.666083°	-98.481500°	F	20	Kk	3	3	5					N,O	5	25	X		X	Hillside
F-2	29.666074°	-98.481302°	F	20	Kk	4	10	5					N,C,F	5	25	X		X	Hillside
MB-1	29.664568°	-98.480317°	MB	30	Kk	5	360	1					N,O	10	40	X		X	Drainage

* DATUM:

2A TYPE	TYPE	2B POINTS
C	Cave	30
SC	Solution cavity	20
SF	Solution-enlarged fracture(s)	20
F	Fault	20
O	Other natural bedrock features	5
MB	Manmade feature in bedrock	30
SW	Swallow hole	30
SH	Sinkhole	20
CD	Non-karst closed depression	5
Z	Zone, clustered or aligned features	30

8A INFILLING	
N	None, exposed bedrock
C	Coarse - cobbles, breakdown, sand, gravel
O	Loose or soft mud or soil, organics, leaves, sticks, dark colors
F	Fines, compacted clay-rich sediment, soil profile, gray or red colors
V	Vegetation. Give details in narrative description
FS	Flowstone, cements, cave deposits
X	Other materials

12 TOPOGRAPHY
Cliff, Hilltop, Hillside, Drainage, Floodplain, Streambed

I have read, I understood, and I have followed the Texas Commission on Environmental Quality's Instructions to Geologists. The information presented here complies with that document and is a true representation of the conditions observed in the field. My signature certifies that I am qualified as a geologist as defined by 30 TAC Chapter 213.

[Signature]

Date 6/10/2020

Sheet ___ of ___

TCEQ-0585-Table (Rev. 10-01-04)



**SITE SPECIFIC
STRATIGRAPHIC COLUMN**

System	Group	Formation	Function	Member or Informal Unit	Function	Thickness Feet	Lithology	Hydrostratigraphy
Cretaceous	Edwards	Kainer (Edwards Aquifer)	AQ	Basal Nodular Bed	CB	40 - 70	Limestone, hard, dense clayey; nodular, mottled, stylolitic.	Subtidal deposits. Negligible porosity and permeability.
	Trinity	Glen Rose	CB	Upper part of Glen Rose	CB	300 - 400	Limestone, dolomite, shale and marl. Alternating beds of carbonates and marls. Evaporites and dolomites toward top; variable bedding.	Supratidal and shoreline deposits towards top. Tidal to subtidal deposits below. Unit has little vertical permeability but has moderate lateral permeability.
				Lower part of Glen Rose	AQ	200 - 250	Massive limestone with few thin beds of marl.	Marine deposits - caprinid reef zones and porous and permeable honeycomb porosity near the base.

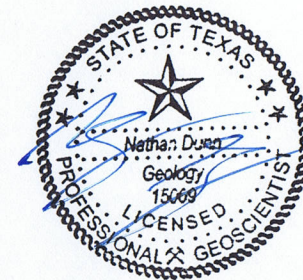

AQ - Aquifer

CB - Confining Bed

(Modified from U.S. Geological Survey Open-File Report 83-537, R. W. Maclay and T. A. Small, 1984)

Site Specific Geology and Soil Characteristics

Approximately 6-Acre Tract

Wilderness Oak and Canyon Golf Road

San Antonio, Texas 78258

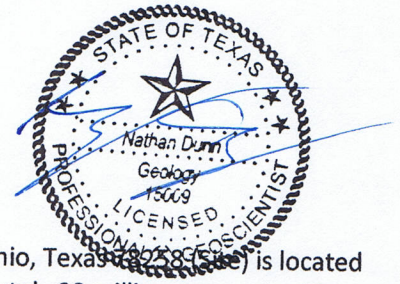

Area Geologic Setting

The approximate 6-acre tract at Wilderness Oak and Canyon Golf Road in San Antonio, Texas (see Figure 1) is located within the Kainer Formation of the Edwards Group, which was deposited approximately 90 million years ago. The Kainer Formation is considered part of the Edwards Aquifer, the primary source of drinking water for San Antonio and other communities in Central Texas.

The Site is located in the Balcones Fault Zone, which separates the Edwards Plateau from the Gulf Coastal Plain physiographic province. The Balcones Fault Zone is a series of steep angle, normal faults that generally strike northeast-southwest. Active movement in the Balcones Fault Zone ceased during the Miocene Epoch. The faulting combined with the exposed lithology of the upper Cretaceous, causes abrupt changes in rock and soil units within the Balcones Fault Zone.

The depositional environment and lithology of the Edwards Group limestones changes from Kinney County in southwest Texas to Hays County east of San Antonio. The Site is located in the San Marcos Arch structural province, which is a distinct depositional province marked by a relatively consistent lithology and stratigraphy of the Cretaceous age limestones, marls, shales, and clays.

The Site is located within the Edwards Group according to the Geologic Atlas of Texas, San Antonio Sheet by W. L. Fisher, Bureau of Economic Geology, Austin, Texas 1983. The entire Edwards Group is approximately 350 feet in thickness. The lithology of the Edwards Group consists of hard, dense calcium carbonate limestone and some magnesium carbonate limestone called dolomite. These limestones are made up of the shells of invertebrate animals that inhabited the shallow seas of the lower Cretaceous period. These shells range from large, reef forming clams to microscopic foraminifers that secrete shells of the mineral calcite or aragonite, which is composed of calcium carbonate. The wide ranges of specific minerals making up the shells that compose the limestone are soluble in water in differing amounts. The preferential dissolution of fossil shells gives rise to many of the karstic geologic features observed in the Edwards Group limestone.

The intense faulting and fracturing of the limestone in the Balcones Fault Zone, and the varying ability of minerals to be dissolved by groundwater, lead to the formation of the geologic features that are mapped within the Edwards Aquifer Recharge Zone. The combination of faulting, fracturing, rock dissolution, mineral deposition, erosion, and geologic time produce caves, non-karst closed depressions, fractured rock outcrops, Fault Zones, solution cavities, and vugular rock features which are mapped during a Geologic Assessment. The characteristics and physical settings of these geologic features are described to assign a relative infiltration rate and potential recharge ranking to assist in managing the resource of the Edwards Aquifer.

The Site is located within the Edwards Aquifer Recharge Zone according to the Edwards Aquifer Recharge Zone and Contributing Zone Map, Edwards Aquifer Authority Rule Chapter 713 by Sarah Eason, Texas Water Development Board, 2014. Therefore, a Geologic Assessment was conducted in accordance with Title 30 of the Texas Administration Code (TAC) Chapter 213.

Site Geology

The Site is located within the Kainer Formation of the Edwards Group, according to Structure Map of the San Antonio Segment of the Edwards Aquifer and Balcones Fault Zone, South-Central Texas: Structural Framework of a Major Limestone Aquifer: Kinney, Uvalde, Medina, Bexar, Comal, and Hays Counties; Edward W. Collins and Susan D. Hovorka, Bureau of Economic Geology, Miscellaneous Map No. 38, 1997. The rock outcrops on the Site showed hard, yellowish gray, dense limestone consistent with the Basal Nodular unit of the Kainer Formation. Evidence of faulting was observed during the field survey conducted during the Geologic Assessment. Linear features were observed during the field survey conducted during the Geologic Assessment.

Eight karstic bedrock features were identified as O-1 through O-8 during the field survey conducted for the Geologic Assessment. Bedrock is abundant throughout the 6-acre tract with an exposed bedrock streambed running parallel to the southeastern border of the site. These features are heavily vegetated and filled with fine grained, organic clay rich sediment; gravel, and cobble. Hand digging exposed bedrock near the surface without apparent fracturing to indicate infiltration was not occurring.

Two karstic zone features were identified as Z-1 and Z-2 during the field survey conducted for the Geologic Assessment. The areas of concern were evaluated by field staff and no discernable visual evidence of rapid infiltration was observed. The fractured, vuggy, lineated outcrops identified were either underlain by unfractured bedrock or filled with the fine grained, organic clay rich sediment.

One manmade bedrock feature was identified as MB-1 during the field survey conducted for the Geologic Assessment. The feature was identified as a stormwater drainage system that begins at the western property boundary and flows southeast into the streambed on the 6-acre tract. The area of concern was evaluated by field staff and no discernable visual evidence of rapid infiltration was observed.

Photographs of the observed features are presented at the end of this section.

Site Soil Characteristics

The Site soil is comprised of Eckrant soils and Rock Outcrop which range in thickness between 0 to 80 inches, according to the Web Soil Survey of Bexar County, Texas, by the United States Department of Agriculture (USDA), 2020. The Eckrant and Rock Outcrop are both listed as Hydrologic Soil Group D, respectively, in Appendix B of Urban Hydrology for Small Watersheds, by the USDA, Natural Resources Conservation Service, Conservation Engineering Division, Technical Release 55, June, 1986.

Assessment

In general, there is a low to intermediate potential for fluid movement from the surface of the Site to the Edwards Aquifer due to the slow to very slow infiltration rate characteristic of clay Group D soil, and a lack of connection between the features and the subsurface relative to the 6-acre assessment area.

GEOLOGIC ASSESSMENT PHOTOGRAPHS

6-Acre Tract

Wilderness Oak and Canyon Golf Road

San Antonio, Texas 78258



Feature O-1: Streambed.



Feature O-2: Streambed.



Feature O-3: Streambed.



Feature O-4: Streambed.



Feature O-5: Hillside.



Feature O-6: Drainage.



Feature O-7: Hillside.



Feature O-8: Hillside.



Feature F-1: Hillside.



Feature F-2: Hillside.



Feature Z-1: Streambed.



Feature Z-2: Streambed.



Feature MB-1: Hillside.



LEGEND	
Kek	KAINER FORMATION (EDWARDS AQUIFER)
●	FEATURE ID
—	MANMADE DRAINAGE FEATURE
—	STREAMBED
—	FAULT LINE

Kek

Kek

Kek

Kek

Kek

Kek

Kek

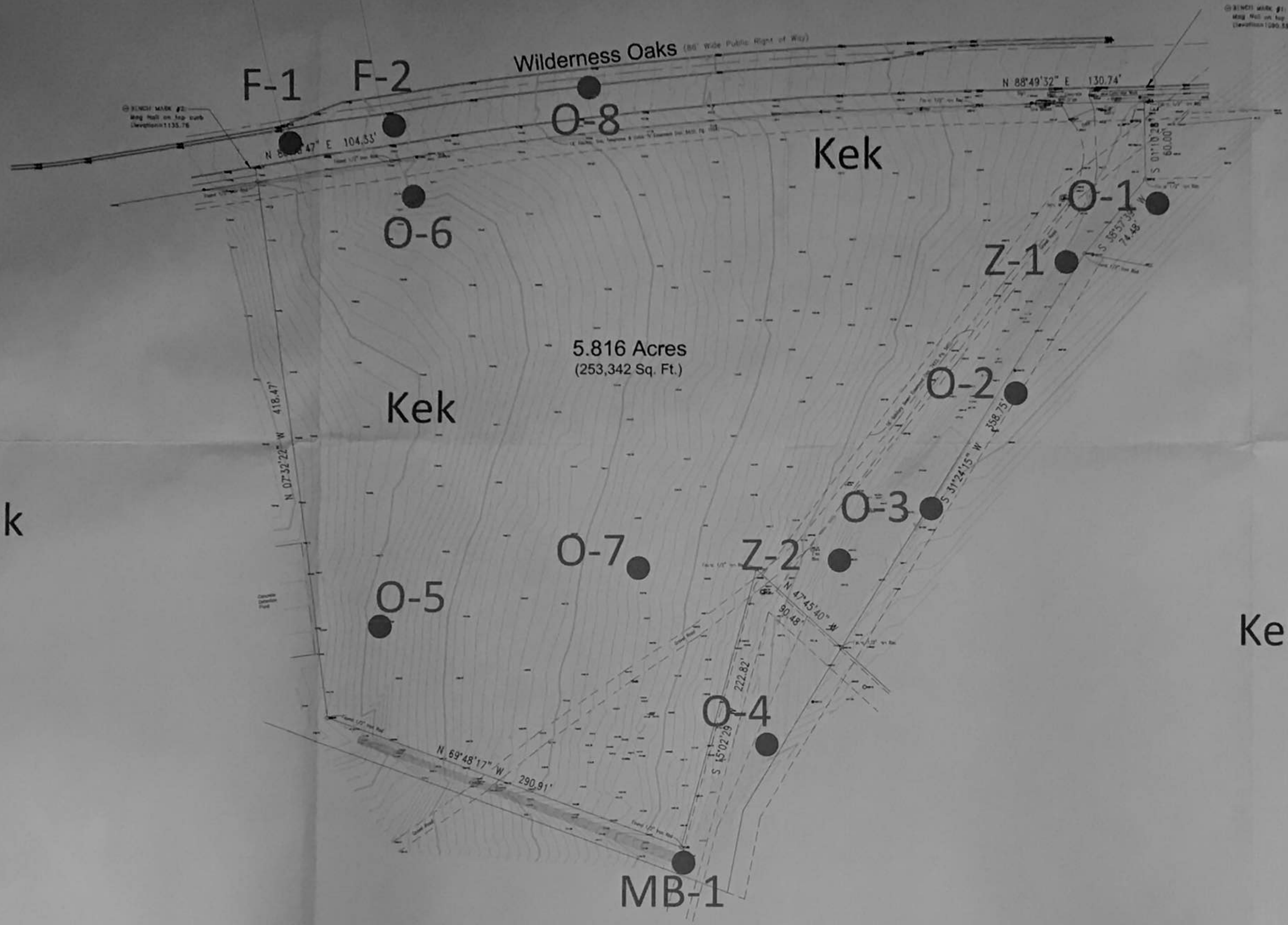

① BENCH MARK #2
Mag Nail on top curb
Elevation 1135.76

② BENCH MARK #1
Mag Nail on top curb
Elevation 1290.55



LEGEND

TaB	ECKKRANT COBBLY CLAY
TaD	ECKKRANT-ROCK OUTCROP



TaD

TaB

TaD

TaD

TaD

TaD

TaD

TaD

5.816 Acres
(253,342 Sq. Ft.)

Wilderness Oaks (56' wide Public Right of Way)

① BENCH MARK #2
Weg. Nail on top curb
Elevation=1135.78

② BENCH MARK #1
Weg. Nail on top curb
Elevation=1090.33

N 80°18'47" E 104.53'

N 88°49'32" E 130.74'

N 07°52'22" W 418.47'

S 01°10'24" E 110.24'

S 85°57'39" W 74.48'

S 31°24'15" W 458.75'

N 47°45'40" W 90.48'

S 45°02'29" W 222.82'

N 69°48'17" W 290.91'

SECTION 4

WATER POLLUTION ABATEMENT PLAN

Water Pollution Abatement Plan Application

Texas Commission on Environmental Quality

for Regulated Activities on the Edwards Aquifer Recharge Zone and Relating to 30 TAC §213.5(b), Effective June 1, 1999

To ensure that the application is administratively complete, confirm that all fields in the form are complete, verify that all requested information is provided, consistently reference the same site and contact person in all forms in the application, and ensure forms are signed by the appropriate party.

Note: Including all the information requested in the form and attachments contributes to more streamlined technical reviews.

Signature

To the best of my knowledge, the responses to this form accurately reflect all information requested concerning the proposed regulated activities and methods to protect the Edwards Aquifer. This **Water Pollution Abatement Plan Application Form** is hereby submitted for TCEQ review and Executive Director approval. The form was prepared by:

Print Name of Customer/Agent: Andrew J. Barboza, P.E.

Date: 12/15/2022

Signature of Customer/Agent:

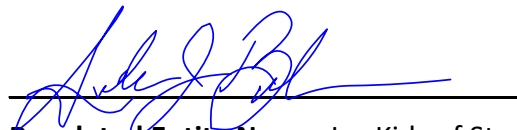

Regulated Entity Name: Ivy Kids of Stone Oak

Regulated Entity Information

1. The type of project is:

- Residential: Number of Lots: _____
- Residential: Number of Living Unit Equivalents: _____
- Commercial
- Industrial
- Other: _____

2. Total site acreage (size of property): 2.757

3. Estimated projected population: N/A

4. The amount and type of impervious cover expected after construction are shown below:

Table 1 - Impervious Cover Table

Impervious Cover of Proposed Project	Sq. Ft.	Sq. Ft./Acre	Acres
Structures/Rooftops	23,900	÷ 43,560 =	0.55
Parking	50,465	÷ 43,560 =	1.16
Other paved surfaces		÷ 43,560 =	
Total Impervious Cover	74,365	÷ 43,560 =	1.71

Total Impervious Cover 1.71 ÷ Total Acreage 2.75 X 100 = 62.18% Impervious Cover

5. **Attachment A - Factors Affecting Surface Water Quality.** A detailed description of all factors that could affect surface water and groundwater quality that addresses ultimate land use is attached.
6. Only inert materials as defined by 30 TAC §330.2 will be used as fill material.

For Road Projects Only

Complete questions 7 - 12 if this application is exclusively for a road project.

7. Type of project:

- TXDOT road project.
- County road or roads built to county specifications.
- City thoroughfare or roads to be dedicated to a municipality.
- Street or road providing access to private driveways.

8. Type of pavement or road surface to be used:

- Concrete
- Asphaltic concrete pavement
- Other: _____

9. Length of Right of Way (R.O.W.): _____ feet.

Width of R.O.W.: _____ feet.

L x W = _____ Ft² ÷ 43,560 Ft²/Acre = _____ acres.

10. Length of pavement area: _____ feet.

Width of pavement area: _____ feet.

L x W = _____ Ft² ÷ 43,560 Ft²/Acre = _____ acres.

Pavement area _____ acres ÷ R.O.W. area _____ acres x 100 = _____% impervious cover.

11. A rest stop will be included in this project.
- A rest stop will not be included in this project.

12. Maintenance and repair of existing roadways that do not require approval from the TCEQ Executive Director. Modifications to existing roadways such as widening roads/adding shoulders totaling more than one-half (1/2) the width of one (1) existing lane require prior approval from the TCEQ.

Stormwater to be generated by the Proposed Project

13. **Attachment B - Volume and Character of Stormwater.** A detailed description of the volume (quantity) and character (quality) of the stormwater runoff which is expected to occur from the proposed project is attached. The estimates of stormwater runoff quality and quantity are based on the area and type of impervious cover. Include the runoff coefficient of the site for both pre-construction and post-construction conditions.

Wastewater to be generated by the Proposed Project

14. The character and volume of wastewater is shown below:

<u>100.0</u> % Domestic	<u>2,760</u> Gallons/day
<u> </u> % Industrial	<u> </u> Gallons/day
<u> </u> % Commingled	<u> </u> Gallons/day
TOTAL gallons/day <u>2,760</u>	

15. Wastewater will be disposed of by:

On-Site Sewage Facility (OSSF/Septic Tank):

Attachment C - Suitability Letter from Authorized Agent. An on-site sewage facility will be used to treat and dispose of the wastewater from this site. The appropriate licensing authority's (authorized agent) written approval is attached. It states that the land is suitable for the use of private sewage facilities and will meet or exceed the requirements for on-site sewage facilities as specified under 30 TAC Chapter 285 relating to On-site Sewage Facilities.

Each lot in this project/development is at least one (1) acre (43,560 square feet) in size. The system will be designed by a licensed professional engineer or registered sanitarian and installed by a licensed installer in compliance with 30 TAC Chapter 285.

Sewage Collection System (Sewer Lines):

Private service laterals from the wastewater generating facilities will be connected to an existing SCS.

Private service laterals from the wastewater generating facilities will be connected to a proposed SCS.

The SCS was previously submitted on _____.

The SCS was submitted with this application.

The SCS will be submitted at a later date. The owner is aware that the SCS may not be installed prior to Executive Director approval.

The sewage collection system will convey the wastewater to the Dos Rios (name) Treatment Plant. The treatment facility is:

- Existing.
 Proposed.

16. All private service laterals will be inspected as required in 30 TAC §213.5.

Site Plan Requirements

Items 17 – 28 must be included on the Site Plan.

17. The Site Plan must have a minimum scale of 1" = 400'.

Site Plan Scale: 1" = 30'.

18. 100-year floodplain boundaries:

Some part(s) of the project site is located within the 100-year floodplain. The floodplain is shown and labeled.

No part of the project site is located within the 100-year floodplain.

The 100-year floodplain boundaries are based on the following specific (including date of material) sources(s): FEMA map #48029C0140G ; 09/29/2010

19. The layout of the development is shown with existing and finished contours at appropriate, but not greater than ten-foot contour intervals. Lots, recreation centers, buildings, roads, open space, etc. are shown on the plan.

The layout of the development is shown with existing contours at appropriate, but not greater than ten-foot intervals. Finished topographic contours will not differ from the existing topographic configuration and are not shown. Lots, recreation centers, buildings, roads, open space, etc. are shown on the site plan.

20. All known wells (oil, water, unplugged, capped and/or abandoned, test holes, etc.):

There are _____ (#) wells present on the project site and the locations are shown and labeled. (Check all of the following that apply)

The wells are not in use and have been properly abandoned.

The wells are not in use and will be properly abandoned.

The wells are in use and comply with 16 TAC §76.

There are no wells or test holes of any kind known to exist on the project site.

21. Geologic or manmade features which are on the site:

All sensitive geologic or manmade features identified in the Geologic Assessment are shown and labeled.

No sensitive geologic or manmade features were identified in the Geologic Assessment.

Attachment D - Exception to the Required Geologic Assessment. A request and justification for an exception to a portion of the Geologic Assessment is attached.

- 22. The drainage patterns and approximate slopes anticipated after major grading activities.
- 23. Areas of soil disturbance and areas which will not be disturbed.
- 24. Locations of major structural and nonstructural controls. These are the temporary and permanent best management practices.
- 25. Locations where soil stabilization practices are expected to occur.
- 26. Surface waters (including wetlands).
 - N/A
- 27. Locations where stormwater discharges to surface water or sensitive features are to occur.
 - There will be no discharges to surface water or sensitive features.
- 28. Legal boundaries of the site are shown.

Administrative Information

- 29. Submit one (1) original and one (1) copy of the application, plus additional copies as needed for each affected incorporated city, groundwater conservation district, and county in which the project will be located. The TCEQ will distribute the additional copies to these jurisdictions. The copies must be submitted to the appropriate regional office.
- 30. Any modification of this WPAP will require Executive Director approval, prior to construction, and may require submission of a revised application, with appropriate fees.

Attachment A – Factors Affecting Surface Water Quality

Potential sources of pollution that may reasonably be expected to affect the quality of storm water discharges from the site during construction include:

- Soil erosion due to the clearing of the site
- Oil grease, fuel and hydraulic fluid contamination from construction equipment and vehicle drippings
- Hydrocarbons from asphalt paving operations
- Miscellaneous trash and litter from construction workers and material wrappings
- Concrete truck washout
- Spills/Overflow from portable toilets

Potential sources of pollution that may reasonably be expected to affect the quality of storm water discharges from the site after development include:

- Oil, grease, fuel and hydraulic fluid contamination from vehicle drippings
- Dirt and dust which may fall off vehicles
- Miscellaneous trash and litter

Attachment B – Volume and Character of Stormwater

The site is currently undeveloped, with slopes of up to 13.0%. The overall runoff coefficient prior to development of the 2.75 acre lot is estimated to be 0.53 based on the existing terrain and slopes. The majority of the stormwater runoff drains southeast towards several underground culverts below Wilderness Oak to then discharge into the Mustang Creek.

The proposed use for this property will be a Day Care Center and Retail of 1.71 acres (62.2%) of impervious cover for the entire site. A weighted c-value of 0.80 was calculated based on the Table 504-1(b) of the City of San Antonio UDC. The site will generate approximately 21.95 cfs during the 25-year storm event. Values were calculated using the Modified Rational Method.

Attachment C – Suitability Letter from Authorized Agent

No OSSF will be used with this project.

Attachment D – Exception to the Required Geologic Assessment

N/A – No exception is being submitted for the Geologic Assessment.

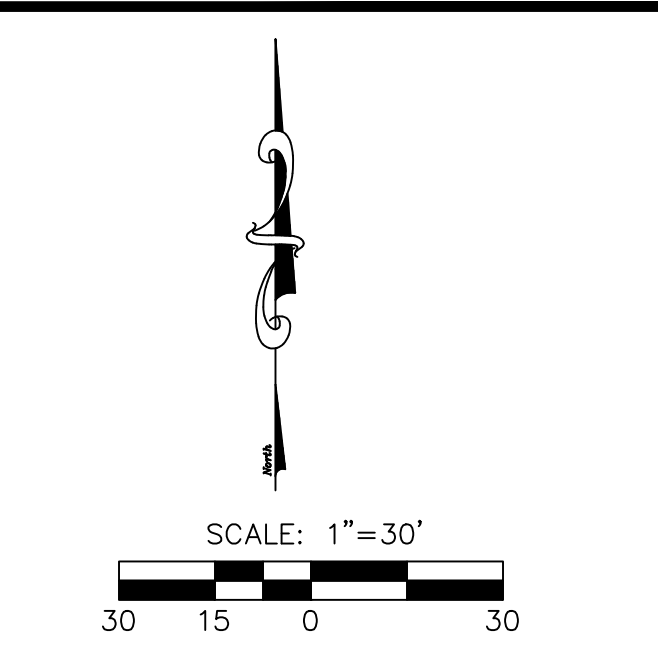
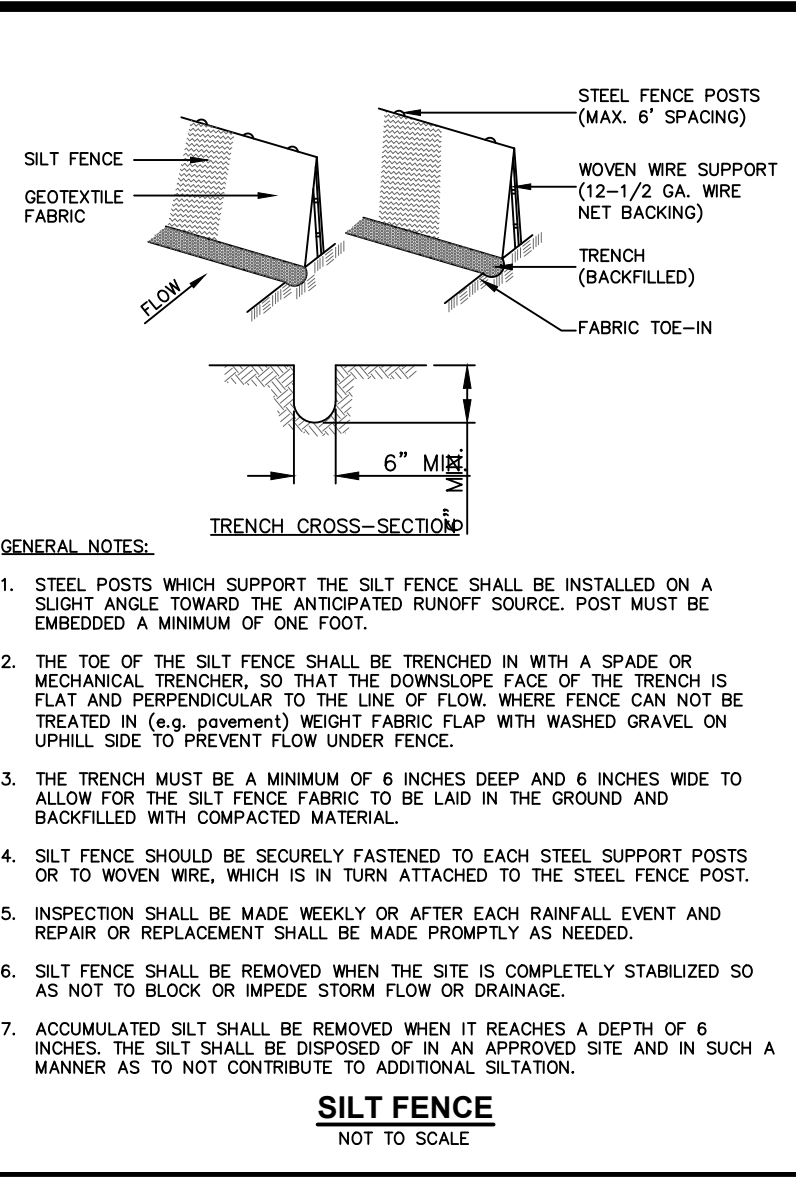
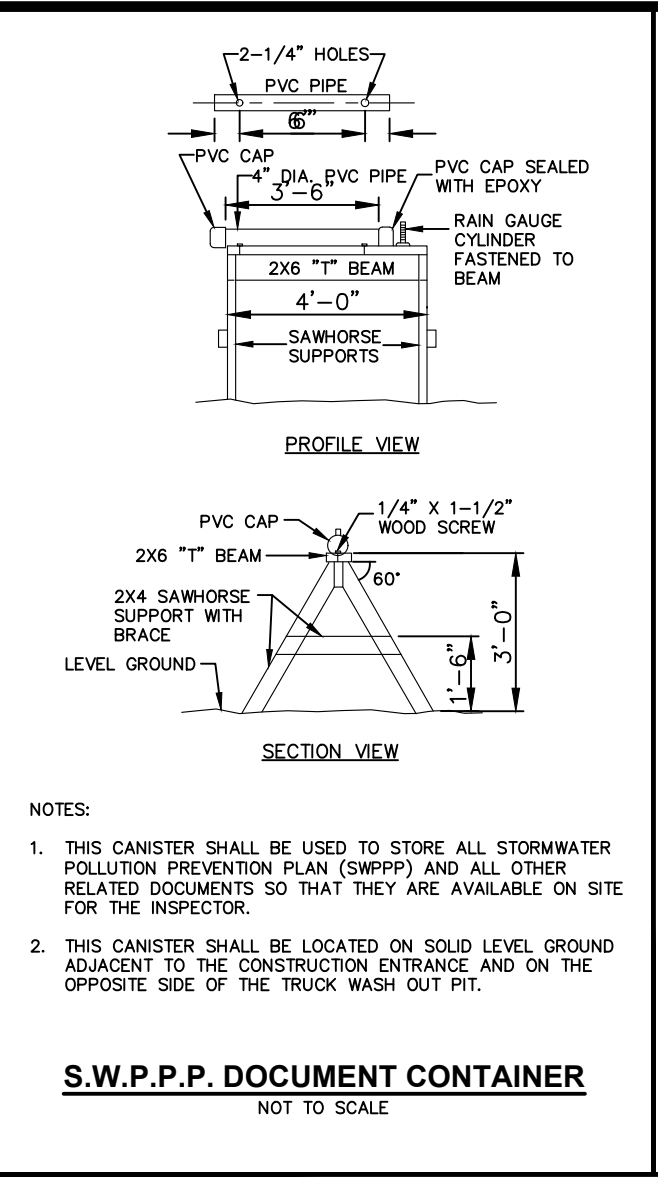
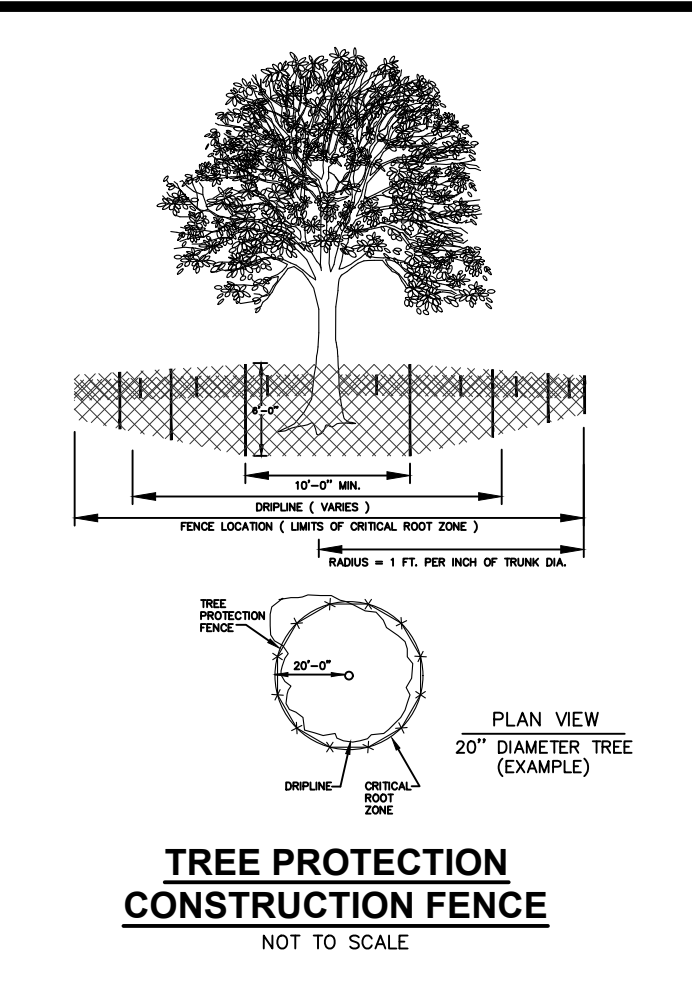
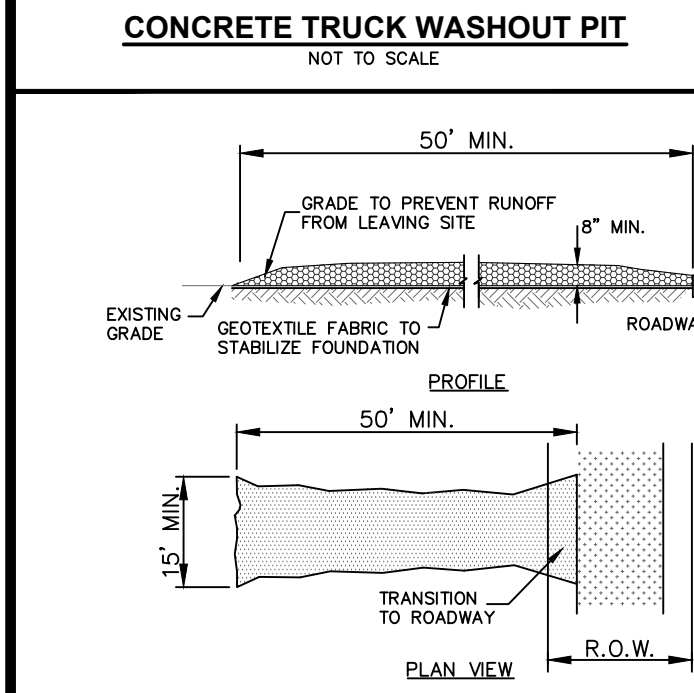
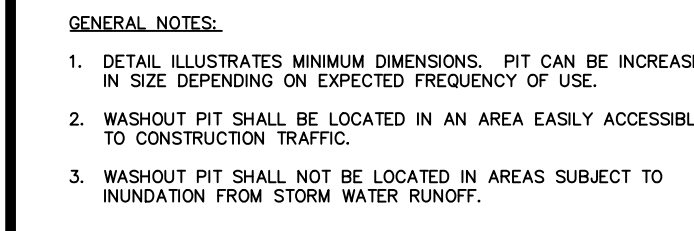
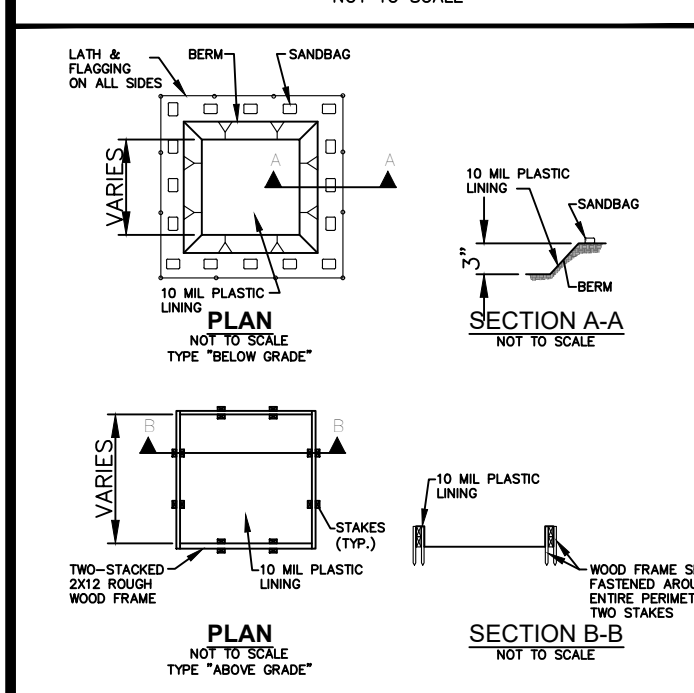
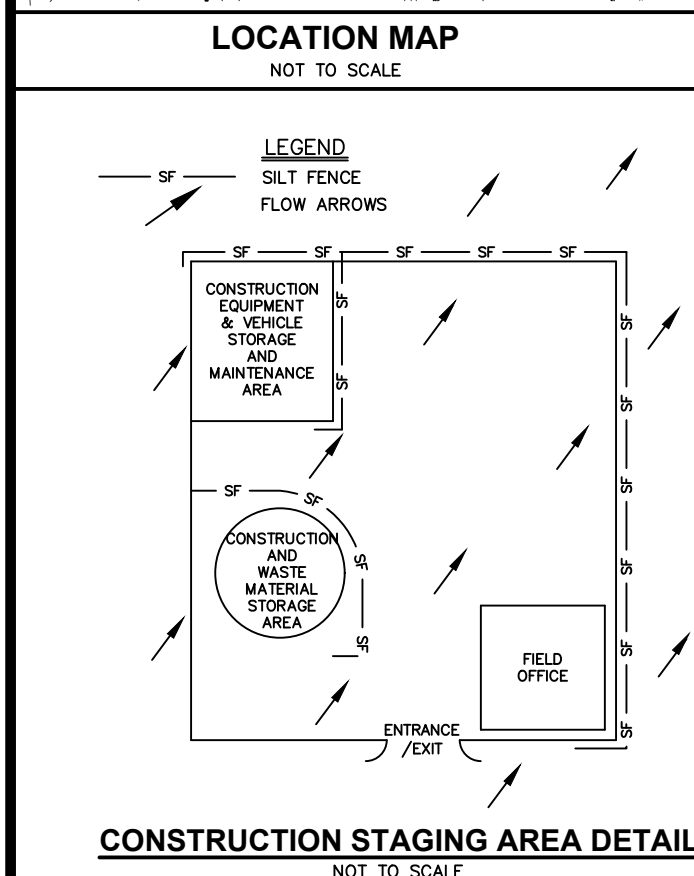
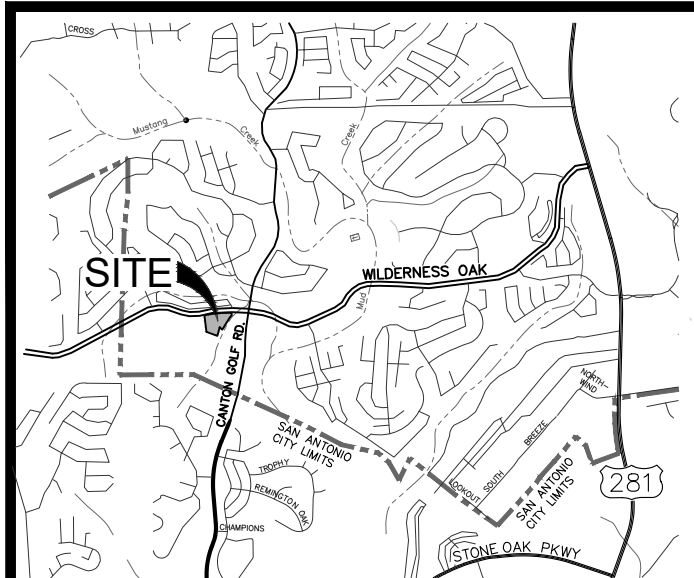

Klove ENGINEERING
Site Development Engineering Services
Firm No. 11042
www.kloveengineering.com
(210) 485-5683

STATE OF TEXAS
ANDREW J. BARBOZA
105872
LICENSED PROFESSIONAL ENGINEER
02/02/2023

REVISIONS:

NO.	DATE	DESCRIPTION

OWNER:
AZEZA HOLDINGS, LLC
11010 COACHLIGHT ST., STE 101
SAN ANTONIO, TEXAS 78216

IVY KIDS OF STONE OAK
24272 WILDERNESS OAK (SHOPPING CENTER)
24278 WILDERNESS OAK (CHILD CARE CENTER)
SAN ANTONIO, TEXAS 78258

DESIGNED BY: AJB
DRAWN BY: RQ
SCALE: 1" = 30'
DATE: 09/26/22
SHEET NO:
EX-1A

Texas Commission on Environmental Quality
Water Pollution Abatement Plan
General Construction Notes

- A written notice of construction must be submitted to the TCEQ regional office at least 48 hours prior to the start of any regulated activities. This notice must include:
 - The name of the approved project.
 - The activity start date; and
 - The contractor information of the primer contractor.
- All contractors conducting regulated activities associated with this project must be provided with complete copies of the approved Water Pollution Abatement Plan (WPAP) and the TCEQ letter indicating the specific conditions of its approval. During the course of these regulated activities, the contractors are required to keep on-site copies of the approved plan and approval letter.
- If any sensitive feature(s) (caves, solution cavity, sink hole, etc.) is discovered during construction, all regulated activities near the sensitive feature must be suspended immediately. The appropriate TCEQ regional office must be immediately notified of any sensitive features encountered during construction. Construction activities may not be resumed until the TCEQ has reviewed and approved the appropriate protective measures in order to protect any sensitive feature and the Edwards Aquifer from potentially adverse impacts to water quality.
- No temporary or permanent hazardous substance storage tank shall be installed within 150 feet of water supply source, distribution system, well, or sensitive feature.
- Prior to beginning any construction activity, all temporary erosion and sedimentation (E&S) control measures must be properly installed and maintained in accordance with the approved plans and manufacturer's specifications. If inspections indicate a control has been used inappropriately, or incorrectly, the applicant must replace or modify the control for site situations. These controls must remain in place until the disturbed areas have been permanently stabilized.
- Any sediment that escapes the construction site must be collected and properly disposed of before the next rain event to ensure it is not washed into surface streams, sensitive features, etc.
- Sediment must be removed from the sediment traps or sedimentation basins not later than when it occupies 50% of the basin's design capacity.
- Litter, construction debris, and construction chemicals exposed to stormwater shall be prevented from being discharged offsite.
- All spoils (excavated material) generated from the project site must be stored on-site with proper E&S controls. For storage or disposal of spoils at another site on the Edwards Aquifer Recharge Zone, the owner of the site must receive approval of a water pollution abatement plan for the placement of fill material or mass grading prior to the placement of spoils at the other site.
- If portions of the site will have temporary or permanent cease in construction activity lasting longer than 14 days, soil stabilization in those areas shall be initiated as soon as possible prior to the 14th day of inactivity. If activity will resume prior to the 21st day, stabilization measures are not required. If drought conditions or inclement weather prevent action by the 14th day, stabilization measures shall be initiated as soon as possible.
- The following records shall be maintained and made available to the TCEQ upon request:
 - the dates when major grading activities occur;
 - the dates when construction activities temporarily or permanently cease on a portion of the site; and
 - the dates when stabilization measures are initiated.
- The holder of any approved Edwards Aquifer protection plan must notify the appropriate regional office in writing and obtain approval from the executive director prior to initiating any of the following:
 - any physical or operational modification of any water pollution abatement structure(s), including but not limited to ponds, dams, berms, sewage treatment plants, and diversionary structures;
 - any change in the nature or character of the regulated activity from that which was originally approved or a change which would significantly impact the ability of the plan to prevent pollution of the Edwards Aquifer;
 - any development of land previously identified as undeveloped in the original water pollution abatement plan.

Austin Regional Office
12100 Park 35 Circle, Building A
Austin, Texas 78753-1808
Phone (512) 339-2929
Fax (512) 339-3795

San Antonio Regional Office
14250 Judson Road
San Antonio, Texas 78233-4480
Phone (210) 490-3096
Fax (210) 545-4329

THESE GENERAL CONSTRUCTION NOTES MUST BE INCLUDED ON THE CONSTRUCTION PLANS PROVIDED TO THE CONTRACTOR AND ALL SUBCONTRACTORS.

Date: Feb 02, 2023, 1:07pm
File: K:\PROJECTS\11383-00-Ivy Kids-Openings\TCEQ\WPAP\4 - WPAP Application\EX-1A - WPAP Site Plan.dwg

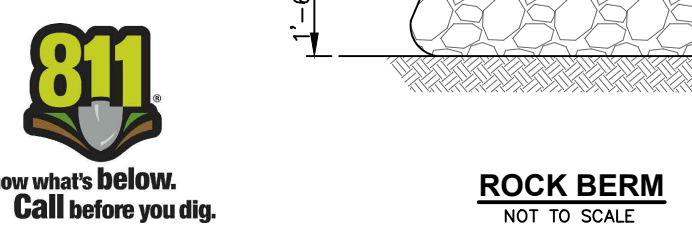

SECTION 5

TEMPORARY STORMWATER

Temporary Stormwater Section

Texas Commission on Environmental Quality

for Regulated Activities on the Edwards Aquifer Recharge Zone and Relating to 30 TAC §213.5(b)(4)(A), (B), (D)(I) and (G); Effective June 1, 1999

To ensure that the application is administratively complete, confirm that all fields in the form are complete, verify that all requested information is provided, consistently reference the same site and contact person in all forms in the application, and ensure forms are signed by the appropriate party.

Note: Including all the information requested in the form and attachments contributes to more streamlined technical reviews.

Signature

To the best of my knowledge, the responses to this form accurately reflect all information requested concerning the proposed regulated activities and methods to protect the Edwards Aquifer. This **Temporary Stormwater Section** is hereby submitted for TCEQ review and executive director approval. The application was prepared by:

Print Name of Customer/Agent: Andrew J. Barboza, P.E.

Date: 12/19/2022

Signature of Customer/Agent:



Regulated Entity Name: Ivy Kids of Stone Oak

Project Information

Potential Sources of Contamination

Examples: Fuel storage and use, chemical storage and use, use of asphaltic products, construction vehicles tracking onto public roads, and existing solid waste.

1. Fuels for construction equipment and hazardous substances which will be used during construction:

The following fuels and/or hazardous substances will be stored on the site: _____

These fuels and/or hazardous substances will be stored in:

- Aboveground storage tanks with a cumulative storage capacity of less than 250 gallons will be stored on the site for less than one (1) year.

- Aboveground storage tanks with a cumulative storage capacity between 250 gallons and 499 gallons will be stored on the site for less than one (1) year.
- Aboveground storage tanks with a cumulative storage capacity of 500 gallons or more will be stored on the site. An Aboveground Storage Tank Facility Plan application must be submitted to the appropriate regional office of the TCEQ prior to moving the tanks onto the project.
- Fuels and hazardous substances will not be stored on the site.
- 2. **Attachment A - Spill Response Actions.** A site specific description of the measures to be taken to contain any spill of hydrocarbons or hazardous substances is attached.
- 3. Temporary aboveground storage tank systems of 250 gallons or more cumulative storage capacity must be located a minimum horizontal distance of 150 feet from any domestic, industrial, irrigation, or public water supply well, or other sensitive feature.
- 4. **Attachment B - Potential Sources of Contamination.** A description of any activities or processes which may be a potential source of contamination affecting surface water quality is attached.

Sequence of Construction

- 5. **Attachment C - Sequence of Major Activities.** A description of the sequence of major activities which will disturb soils for major portions of the site (grubbing, excavation, grading, utilities, and infrastructure installation) is attached.
 - For each activity described, an estimate (in acres) of the total area of the site to be disturbed by each activity is given.
 - For each activity described, include a description of appropriate temporary control measures and the general timing (or sequence) during the construction process that the measures will be implemented.
- 6. Name the receiving water(s) at or near the site which will be disturbed or which will receive discharges from disturbed areas of the project: Mustang Creek

Temporary Best Management Practices (TBMPs)

Erosion control examples: tree protection, interceptor swales, level spreaders, outlet stabilization, blankets or matting, mulch, and sod. Sediment control examples: stabilized construction exit, silt fence, filter dikes, rock berms, buffer strips, sediment traps, and sediment basins. Please refer to the Technical Guidance Manual for guidelines and specifications. All structural BMPs must be shown on the site plan.

- 7. **Attachment D – Temporary Best Management Practices and Measures.** TBMPs and measures will prevent pollution of surface water, groundwater, and stormwater. The construction-phase BMPs for erosion and sediment controls have been designed to retain sediment on site to the extent practicable. The following information is attached:

- A description of how BMPs and measures will prevent pollution of surface water, groundwater or stormwater that originates upgradient from the site and flows across the site.
 - A description of how BMPs and measures will prevent pollution of surface water or groundwater that originates on-site or flows off site, including pollution caused by contaminated stormwater runoff from the site.
 - A description of how BMPs and measures will prevent pollutants from entering surface streams, sensitive features, or the aquifer.
 - A description of how, to the maximum extent practicable, BMPs and measures will maintain flow to naturally-occurring sensitive features identified in either the geologic assessment, TCEQ inspections, or during excavation, blasting, or construction.
8. The temporary sealing of a naturally-occurring sensitive feature which accepts recharge to the Edwards Aquifer as a temporary pollution abatement measure during active construction should be avoided.
- Attachment E - Request to Temporarily Seal a Feature.** A request to temporarily seal a feature is attached. The request includes justification as to why no reasonable and practicable alternative exists for each feature.
 - There will be no temporary sealing of naturally-occurring sensitive features on the site.
9. **Attachment F - Structural Practices.** A description of the structural practices that will be used to divert flows away from exposed soils, to store flows, or to otherwise limit runoff discharge of pollutants from exposed areas of the site is attached. Placement of structural practices in floodplains has been avoided.
10. **Attachment G - Drainage Area Map.** A drainage area map supporting the following requirements is attached:
- For areas that will have more than 10 acres within a common drainage area disturbed at one time, a sediment basin will be provided.
 - For areas that will have more than 10 acres within a common drainage area disturbed at one time, a smaller sediment basin and/or sediment trap(s) will be used.
 - For areas that will have more than 10 acres within a common drainage area disturbed at one time, a sediment basin or other equivalent controls are not attainable, but other TBMPs and measures will be used in combination to protect down slope and side slope boundaries of the construction area.
 - There are no areas greater than 10 acres within a common drainage area that will be disturbed at one time. A smaller sediment basin and/or sediment trap(s) will be used in combination with other erosion and sediment controls within each disturbed drainage area.

- There are no areas greater than 10 acres within a common drainage area that will be disturbed at one time. Erosion and sediment controls other than sediment basins or sediment traps within each disturbed drainage area will be used.
11. **Attachment H - Temporary Sediment Pond(s) Plans and Calculations.** Temporary sediment pond or basin construction plans and design calculations for a proposed temporary BMP or measure have been prepared by or under the direct supervision of a Texas Licensed Professional Engineer. All construction plans and design information must be signed, sealed, and dated by the Texas Licensed Professional Engineer. Construction plans for the proposed temporary BMPs and measures are attached.
- N/A
12. **Attachment I - Inspection and Maintenance for BMPs.** A plan for the inspection of each temporary BMP(s) and measure(s) and for their timely maintenance, repairs, and, if necessary, retrofit is attached. A description of the documentation procedures, recordkeeping practices, and inspection frequency are included in the plan and are specific to the site and/or BMP.
13. All control measures must be properly selected, installed, and maintained in accordance with the manufacturer's specifications and good engineering practices. If periodic inspections by the applicant or the executive director, or other information indicate a control has been used inappropriately, or incorrectly, the applicant must replace or modify the control for site situations.
14. If sediment escapes the construction site, off-site accumulations of sediment must be removed at a frequency sufficient to minimize offsite impacts to water quality (e.g., fugitive sediment in street being washed into surface streams or sensitive features by the next rain).
15. Sediment must be removed from sediment traps or sedimentation ponds not later than when design capacity has been reduced by 50%. A permanent stake will be provided that can indicate when the sediment occupies 50% of the basin volume.
16. Litter, construction debris, and construction chemicals exposed to stormwater shall be prevented from becoming a pollutant source for stormwater discharges (e.g., screening outfalls, picked up daily).

Soil Stabilization Practices

Examples: establishment of temporary vegetation, establishment of permanent vegetation, mulching, geotextiles, sod stabilization, vegetative buffer strips, protection of trees, or preservation of mature vegetation.

17. **Attachment J - Schedule of Interim and Permanent Soil Stabilization Practices.** A schedule of the interim and permanent soil stabilization practices for the site is attached.

18. Records must be kept at the site of the dates when major grading activities occur, the dates when construction activities temporarily or permanently cease on a portion of the site, and the dates when stabilization measures are initiated.
19. Stabilization practices must be initiated as soon as practicable where construction activities have temporarily or permanently ceased.

Administrative Information

20. All structural controls will be inspected and maintained according to the submitted and approved operation and maintenance plan for the project.
21. If any geologic or manmade features, such as caves, faults, sinkholes, etc., are discovered, all regulated activities near the feature will be immediately suspended. The appropriate TCEQ Regional Office shall be immediately notified. Regulated activities must cease and not continue until the TCEQ has reviewed and approved the methods proposed to protect the aquifer from any adverse impacts.
22. Silt fences, diversion berms, and other temporary erosion and sediment controls will be constructed and maintained as appropriate to prevent pollutants from entering sensitive features discovered during construction.

TEMPORARY STORMWATER SECTION

ATTACHMENT A

Spill Response Actions

In the event of an accidental leak or spill:

- Contractor shall take immediate action to contain a spill. The contractor may use sand or other absorbent material stockpiled on site to absorb a spill. Absorbent material should be spread over the spill area to absorb the spilled product.
- In the event of an uncontained discharge the contractor shall utilize onsite equipment to construct berms down gradient of the spill with sand or other absorbent material to contain and absorb the spilled product.
- Sand or material used to contain the spill should be collected and stored in such a way so as not to continue to affect additional ground. Once the spill has been contained, collected material should be placed on poly or plastic sheeting until removed from the site. In the event of potential rainfall, the material should be covered with poly or plastic sheeting to prevent contaminating runoff.
- The contractor will be required to notify the owner, who will in turn contact TCEQ to notify them in the event of a spill. Additional notifications as required by the type and amount of spill will be conducted by the owner or owner's representative.

In the event of an accidental significant or hazardous spill:

- the contractor will be required to report significant or hazardous spills in reportable quantities to:
 - the National Response Center at (800) 424-8802
 - the Edwards Aquifer Authority at (210) 222-2204
 - the TCEQ Regional Office (210) 490-3096 (if during business hours: 8 am to 5 pm) or
 - the State Emergency Response Center (800) 832-8224 (if after hours)
- Contaminated soils will be sampled for waste characterization. When the analysis results are known the contaminated soils will be removed from the site and disposed of in a permitted landfill in accordance with applicable regulations.

Additional guidance can be obtained from TCEQ's Technical Guidance Manual (TGM) RG-348 (2005) Section 1.4.16. Contractor shall review this section.

TEMPORARY STORMWATER SECTION

TCEQ's TGM Section 1.4.16 Spill Prevention and Control

The objective of this section is to describe measures to prevent or reduce the discharge of pollutants to drainage systems or watercourses from leaks and spills by reducing the chance for spill, stopping the source of spills, containing and cleaning up spills, properly disposing of spill materials, and training employees.

The following steps will help reduce the storm water impacts of leaks and spills:

Education

- (1) Be aware that different materials pollute in different amounts. Make sure that each employee knows what a "significant spill" is for each material they use, and what is the appropriate response for "significant" and "insignificant" spills. Employees should also be aware of when spills must be reported to the TCEQ. Information available in 30 TAC 327.4 and 40 CFR 302.4
- (2) Educate employees and subcontractors on potential dangers to humans and the environment from spills and leaks.
- (3) Hold regular meetings to discuss and reinforce appropriate disposal procedures (incorporate into regular safety meetings).
- (4) Establish a continuing education program to indoctrinate new employees.
- (5) Have contractor's superintendent or representative oversee and enforce proper spill prevention and control measures.

General Measures

- (1) To the extent that the work can be accomplished safely, spills of oil, petroleum products, substances listed under 40 CFR parts 110, 117, and 302, and sanitary and septic wastes should be contained and cleaned up immediately.
- (2) Store hazardous materials and wastes in covered containers and protect from vandalism.
- (3) Place a stockpile of spill cleanup materials where it will be readily accessible.
- (4) Train employees in spill prevention and cleanup.
- (5) Designate responsible individuals to oversee and enforce control measures.
- (6) Spills should be covered and protected from storm water runoff during rainfall to the extent that it doesn't compromise cleanup activities.
- (7) Do not bury or wash spills with water.
- (8) Store and dispose of used cleanup materials, contaminated materials, and recovered spill material that is no longer suitable for the intended purpose in conformance with the provisions in applicable BMP's.
- (9) Do not allow water used for cleaning and decontamination to enter storm drains or watercourses. Collect and dispose of contaminated water in accordance with applicable regulations.

TEMPORARY STORMWATER SECTION

- (10) Contain water overflow or minor water spillage and do not allow it to discharge into drainage facilities or watercourses.
- (11) Place Material Safety Data Sheets (MSDS), as well as proper storage, cleanup, and spill reporting instructions for hazardous materials stored or used on the project site in an open, conspicuous, and accessible location.
- (12) Keep waste storage areas clean, well organized, and equipped with ample cleanup supplies as appropriate for the materials being stored. Perimeter controls, containment structures, covers and liners should be repaired or replaced as needed to maintain proper function.

Cleanup

- (1) Clean up leaks and spills immediately.
- (2) Use a rag for small spills on paved surfaces, a damp mop for general cleanup, and absorbent material for larger spills. If the spilled material is hazardous, then the used cleanup materials are also hazardous and must be disposed of as hazardous waste.
- (3) Never hose down or bury dry material spills. Clean up as much of the material as possible and dispose of properly. See the waste management BMPs in this section for specific information.

Minor Spills

- (1) Minor spills typically involve small quantities of oil, gasoline, paint, etc. which can be controlled by the first responder at the discovery of the spill.
- (2) Use absorbent materials on small spills rather than hosing down or burying in the spill.
- (3) Absorbent materials should be promptly removed and disposed of properly.
- (4) Follow the practice below for a minor spill:
- (5) Contain the spread of the spill.
- (6) Recover spilled materials.
- (7) Clean the contaminated area and properly dispose of contaminated materials.

Semi-Significant Spills

Semi-significant spills still can be controlled by the first responder along with the aid of other personnel such as laborers and the foreman, etc. This response may require the cessation of all other activities.

Spills should be cleaned up immediately:

- (1) Contain spread of the spill.
- (2) Notify the project foreman immediately.
- (3) If the spill occurs on paved or impermeable surfaces, clean up using "dry" methods (absorbent materials, cat litter and/or rags). Contain the spill by encircling with absorbent materials and do not let the spill spread widely.
- (4) If the spill occurs in dirt areas, immediately contain the spill by constructing an earthen dike. Dig up and properly dispose of contaminated soil.
- (5) If the spill occurs during rain, cover spill with tarps or other material to prevent contaminating runoff.

TEMPORARY STORMWATER SECTION

Significant/Hazardous Spills

For significant or hazardous spills that are in reportable quantities:

- (1) Notify the TCEQ by telephone as soon as possible and within 24 hours at 512-339-2929 (Austin) or 210-490-3096 (San Antonio) between 8 AM and 5 PM. After hours, contact the Environmental Release Hotline at 1-800-832-8224. It is the contractor's responsibility to have all emergency phone numbers at the construction site.
- (2) For spills of federal reportable quantities, in conformance with the requirements in 40 CFR parts 110, 119, and 302, the contractor should notify the National Response Center at (800) 424-8802.
- (3) Notification should first be made by telephone and followed up with a written report.
- (4) The services of a spills contractor or a Haz-Mat team should be obtained immediately. Construction personnel should not attempt to clean up until the appropriate and qualified staffs have arrived at the job site.
- (5) Other agencies which may need to be consulted include, but are not limited to the City Police Department, County Sheriff Office, Fire Departments, etc.

More information on spill rules and appropriate responses are available on the TCEQ website at: http://www.tnrcc.state.tx.us/enforcement/emergency_response.html

Vehicle and Equipment Maintenance

- (1) If maintenance must occur onsite, use a designated area and a secondary containment located away from drainage courses to prevent the runoff of storm water and the runoff of spills.
- (2) Regularly inspect onsite vehicles and equipment for leaks and repair immediately.
- (3) Check incoming vehicles and equipment (including delivery trucks, and employee and subcontractor vehicles) for leaking oil and fluids. Do not allow leaking vehicles or equipment onsite.
- (4) Always use secondary containment, such as a drain pan or drop cloth, to catch spills or leaks when removing or changing fluids.
- (5) Place drip pans or absorbent materials under paving equipment when not in use.
- (6) Use absorbent materials on small spills rather than hosing down or burying the spill. Remove the absorbent materials promptly and dispose of properly.
- (7) Promptly transfer used fluids to the proper waste or recycling drums. Don't leave full drip pans or other open containers lying around.
- (8) Oil filters disposed of in trashcans or dumpsters can leak oil and pollute storm water. Place the oil filter in a funnel over a waste oil-recycling drain to drain excess oil before disposal. Oil filters can also be recycled. Ask the oil supplier or recycler about recycling oil filters.
- (9) Store cracked batteries in a non-leaking secondary container. Do this with all cracked batteries even if you think all the acid has drained out. If you drop a battery, treat it as if it is cracked. Put it into the containment area until you are sure it is not leaking.

TEMPORARY STORMWATER SECTION

Vehicle and Equipment Fueling

- (1) If fueling must occur on site, use designated areas, located away from drainage courses, to prevent the run-on of storm water and the runoff of spills.
- (2) Discourage "topping off" of fuel tanks.
- (3) Always use secondary containment, such as a drain pan, when fueling to catch spills/leaks.

TEMPORARY STORMWATER SECTION

ATTACHMENT B

Potential Sources of Contamination

Potential Sources:

1. Asphalt products used by this project.
2. Oil, grease, fuel and hydraulic fluid contamination from construction equipment and vehicle dripping.
3. Accidental leaks or spills of oil, petroleum products and substances listed under 40 CFR parts 110, 117, and 302 used or stored temporarily on site.
4. Miscellaneous trash and litter from construction workers and materials wrappings.
5. Construction debris.
6. Spills/Overflow of waste from portable toilets.

Preventative Measure:

1. After placement of asphalt, emulsion or coatings, the contractor will be responsible for immediate cleanup should an unexpected rain occur. For the duration of the asphalt product curing time, the contractor will maintain standby personnel and equipment to contain any asphalt wash-off should an unexpected rain occur. The contractor will be instructed not to place asphalt products on the ground within 48 hours of a forecasted rain.
2. Vehicle maintenance when possible will be performed within the construction staging area. Construction vehicles and equipment shall be checked regularly for leaks and repaired immediately.
3. Contractor to incorporate into regular safety meetings, a discussion of spill prevention and appropriate disposal procedures. Contractor's superintendent or representative oversee shall enforce proper spill prevention and control measures. Hazardous materials and wastes shall be stored in covered containers and protected from vandalism. A stockpile of spill cleanup materials shall be stored on site where it will be readily accessible.
4. Trash containers will be placed throughout the site to encourage proper trash disposal.
5. Construction debris will be monitored daily by contractor. Debris will be collected weekly and placed in disposal bins. Situations requiring immediate attention will be addressed on a case by case basis.
6. Portable toilets will be placed away from high traffic vehicular areas and storm drain inlets on a level ground surface. Portable toilets will be inspected regularly for leaks and will be serviced and sanitized at time intervals that will maintain sanitary conditions.

TEMPORARY STORMWATER SECTION

ATTACHMENT C

Sequence of Major Activities

The sequence of major activities which disturb soil during construction on this site will consist of two stages. Stage one will include site preparation that will include clearing and grubbing of vegetation where applicable and rough grading. This will disturb approximately 2.48 acres. The second stage is the construction stage that will include the buildings, paved parking, sidewalks, landscaping and site cleanup. This will disturb approximately 2.48 acres.

TEMPORARY STORMWATER SECTION

ATTACHMENT D

Temporary Best Management Practices and Measures

Silt Fence

- Placed on the down gradient slope of the disturbed areas to catch sediment before it leaves the site. Temporary measure, to be removed once the disturbance activities have ceased and stabilization completed. See details on the SWPPP sheet.

Construction Exit

- Located at the entrance/exit of the site and used to reduce materials from being tracked onto existing roads from construction vehicles. Usually consists of oversized rock gravel that will allow for material to fall off vehicles therefore reducing the amount of material that leaves the site. See SWPPP sheet for location and specifications.

Concrete Washout Pit

- Designed to trap and store waste from concrete and similar activities. This allows for safe storage and removal from the site by not allowing contaminants to enter the storm water. Contaminants can be kept in a location that will not allow storm water to mix and flow off the site. See SWPPP sheet for location and specifications.

TEMPORARY STORMWATER SECTION

ATTACHMENT E

Request to Temporarily Seal a Feature

No features will be sealed within the site.

TEMPORARY STORMWATER SECTION

ATTACHMENT F

The following structural measures will be installed prior to the initiation of site preparation activities:

- Temporary Construction Entrance/Exit

The purpose of a temporary gravel construction entrance is to provide a stable entrance/exit condition from the construction site and keep mud and sediment off public roads. A stabilized construction entrance is a stabilized pad of crushed stone located at any point traffic will be entering or leaving the construction site from a public right-of-way, street, alley, sidewalk or parking area. The purpose of a stabilized construction entrance is to reduce or eliminate the tracking or flowing of sediment onto public rights-of-way. This practice should be used at all points of construction ingress and egress. Schematic diagrams of a construction entrance/exit are shown in Figure 1-24 and Figure 1-25.

Excessive amounts of mud can also present a safety hazard to roadway users. To minimize the amount of sediment loss to nearby roads, access to the construction site should be limited to as few points as possible and vegetation around the perimeter should be protected where access is not necessary. A rock stabilized construction entrance should be used at all designated access points.

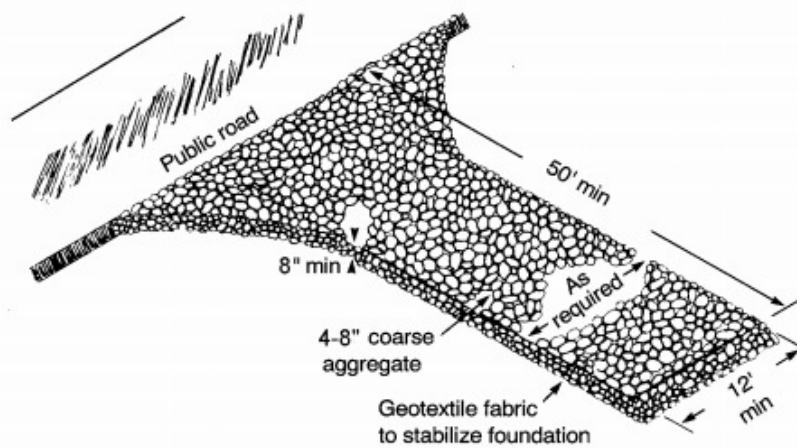

Figure 1-24 Schematic of Temporary Construction Entrance/Exit (after NC, 1993)

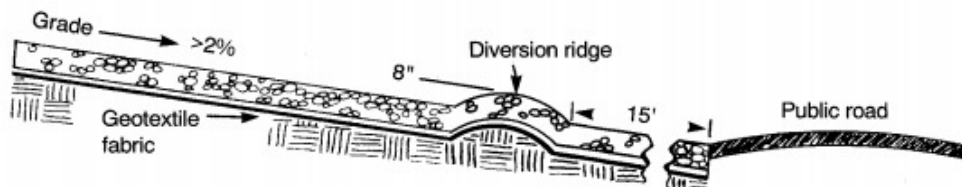

Figure 1-25 Cross-section of a Construction Entrance/Exit (NC, 1993)

TEMPORARY STORMWATER SECTION

Materials:

- (1) The aggregate should consist of 4 to 8 inch washed stone over a stable foundation as specified in the plan.
- (2) The aggregate should be placed with a minimum thickness of 8 inches.
- (3) The geotextile fabric should be designed specifically for use as a soil filtration media with an approximate weight of 6 oz/yd² , a mullen burst rating of 140 lb/in² , and an equivalent opening size greater than a number 50 sieve.
- (4) If a washing facility is required, a level area with a minimum of 4 inch diameter washed stone or commercial rack should be included in the plans. Divert wastewater to a sediment trap or basin.

Installation: (North Carolina, 1993)

- (1) Avoid curves on public roads and steep slopes. Remove vegetation and other objectionable material from the foundation area. Grade crown foundation for positive drainage.
- (2) The minimum width of the entrance/exit should be 12 feet or the full width of exit roadway, whichever is greater.
- (3) The construction entrance should be at least 50 feet long.
- (4) If the slope toward the road exceeds 2%, construct a ridge, 6 to 8 inches high with 3:1 (H:V) side slopes, across the foundation approximately 15 feet from the entrance to divert runoff away from the public road.
- (5) Place geotextile fabric and grade foundation to improve stability, especially where wet conditions are anticipated.
- (6) Place stone to dimensions and grade shown on plans. Leave surface smooth and slope for drainage.
- (7) Divert all surface runoff and drainage from the stone pad to a sediment trap or basin.
- (8) Install pipe under pad as needed to maintain proper public road drainage.

- Silt Fence

A silt fence is a barrier consisting of geotextile fabric supported by metal posts to prevent soil and sediment loss from a site. When properly used, silt fences can be highly effective at controlling sediment from disturbed areas. They cause runoff to pond, allowing heavier solids to settle out. If not properly installed, silt fences are not likely to be effective. A schematic illustration of a silt fence is shown in Figure 1-26.

TEMPORARY STORMWATER SECTION

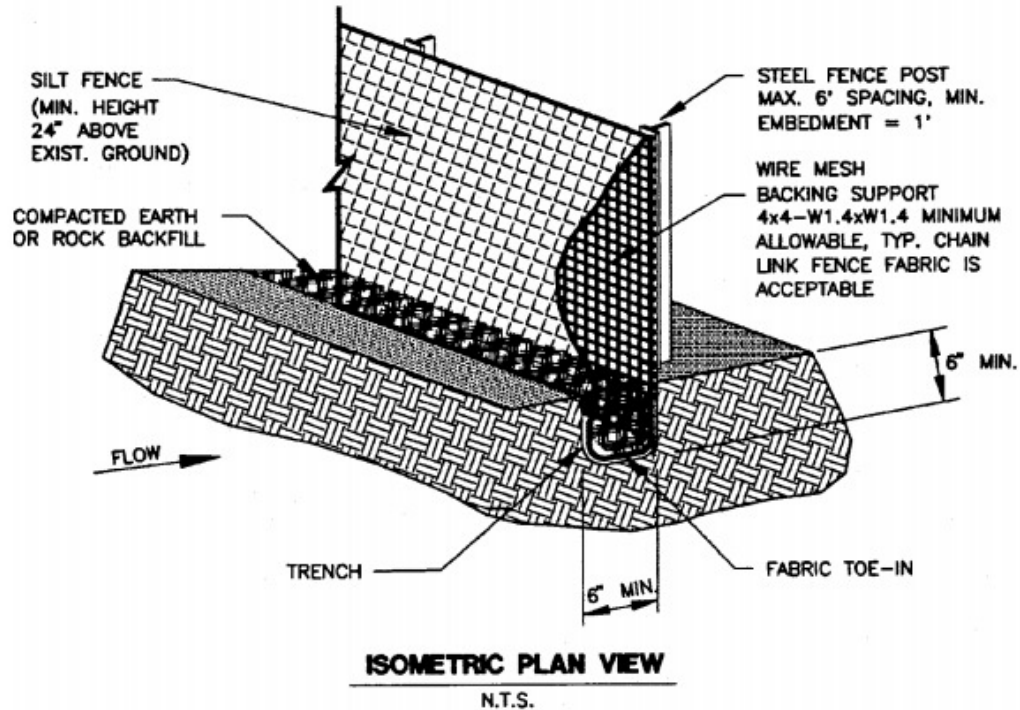

Figure 1-26 Schematic of a Silt Fence Installation (NCTCOG, 1993b)

The purpose of a silt fence is to intercept and detain water-borne sediment from unprotected areas of a limited extent. Silt fence is used during the period of construction near the perimeter of a disturbed area to intercept sediment while allowing water to percolate through. This fence should remain in place until the disturbed area is permanently stabilized. Silt fence should not be used where there is a concentration of water in a channel or drainage way. If concentrated flow occurs after installation, corrective action must be taken such as placing a rock berm in the areas of concentrated flow. 1-67 Silt fencing within the site may be temporarily moved during the day to allow construction activity provided it is replaced and properly anchored to the ground at the end of the day. Silt fences on the perimeter of the site or around drainage ways should not be moved at any time.

Materials:

- (1) Silt fence material should be polypropylene, polyethylene or polyamide woven or nonwoven fabric. The fabric width should be 36 inches, with a minimum unit weight of 4.5 oz/yd, mullen burst strength exceeding 190 lb/in², ultraviolet stability exceeding 70%, and minimum apparent opening size of U.S. Sieve No. 30.
- (2) Fence posts should be made of hot rolled steel, at least 4 feet long with Tee or Ybar cross section, surface painted or galvanized, minimum nominal weight 1.25 lb/ft², and Brindell hardness exceeding 140.
- (3) Woven wire backing to support the fabric should be galvanized 2" x 4" welded wire, 12 gauge minimum.

Installation:

TEMPORARY STORMWATER SECTION

- (1) Steel posts, which support the silt fence, should be installed on a slight angle toward the anticipated runoff source. Post must be embedded a minimum of 1- foot deep and spaced not more than 8 feet on center. Where water concentrates, the maximum spacing should be 6 feet.
- (2) Lay out fencing down-slope of disturbed area, following the contour as closely as possible. The fence should be sited so that the maximum drainage area is ¼ acre/100 feet of fence.
- (3) The toe of the silt fence should be trenched in with a spade or mechanical trencher, so that the down-slope face of the trench is flat and perpendicular to the line of flow. Where fence cannot be trenched in (e.g., pavement or rock outcrop), weight fabric flap with 3 inches of pea gravel on uphill side to prevent flow from seeping under fence.
- (4) The trench must be a minimum of 6 inches deep and 6 inches wide to allow for the silt fence fabric to be laid in the ground and backfilled with compacted material.
- (5) Silt fence should be securely fastened to each steel support post or to woven wire, which is in turn attached to the steel fence post. There should be a 3-foot overlap, securely fastened where ends of fabric meet. 1-68
- (6) Silt fence should be removed when the site is completely stabilized so as not to block or impede storm flow or drainage.

- Inlet Protection

Storm sewers that are made operational prior to stabilization of the associated drainage areas can convey large amounts of sediment to natural drainage ways. In case of extreme sediment loading, the storm sewer itself may clog and lose a major portion of its capacity. To avoid these problems, it is necessary to prevent sediment from entering the system at the inlets. The following guidelines for inlet protection are based primarily on recommendations by the Virginia Dept. of Conservation and Recreation (1992) and the North Central Texas Council of Governments (NCTCOG, 1993b). In developments for which drainage is to be conveyed by underground storm sewers (i.e., streets with curbs and gutters), all inlets that may receive storm runoff from disturbed areas should be protected.

Materials:

- (1) Filter fabric should be a nylon reinforced polypropylene fabric which meets the following minimum criteria: Tensile Strength, 90 lbs.; Puncture Rating, 60 lbs.; Mullen Burst Rating, 280 psi; Apparent Opening Size, U.S. Sieve No. 70.
- (2) Posts for fabric should be 2" x 4" pressure treated wood stakes or galvanized steel, tubular in cross-section or they may be standard fence "T" posts.
- (3) Concrete blocks should be standard 8" x 8" x 16" concrete masonry units.
- (4) Wire mesh should be standard hardware cloth or comparable wire mesh with an opening size not to exceed 1/2 inch.

Installation:

Gravel and Wire Mesh Drop Inlet Sediment Filter

- (1) Wire mesh should be laid over the drop inlet so that the wire extends a minimum of 1 foot beyond each side of the inlet structure. Wire mesh with 1/2-inch openings should be used. If more than one strip of mesh is necessary, the strips should be overlapped (see Figure 1-34).

TEMPORARY STORMWATER SECTION

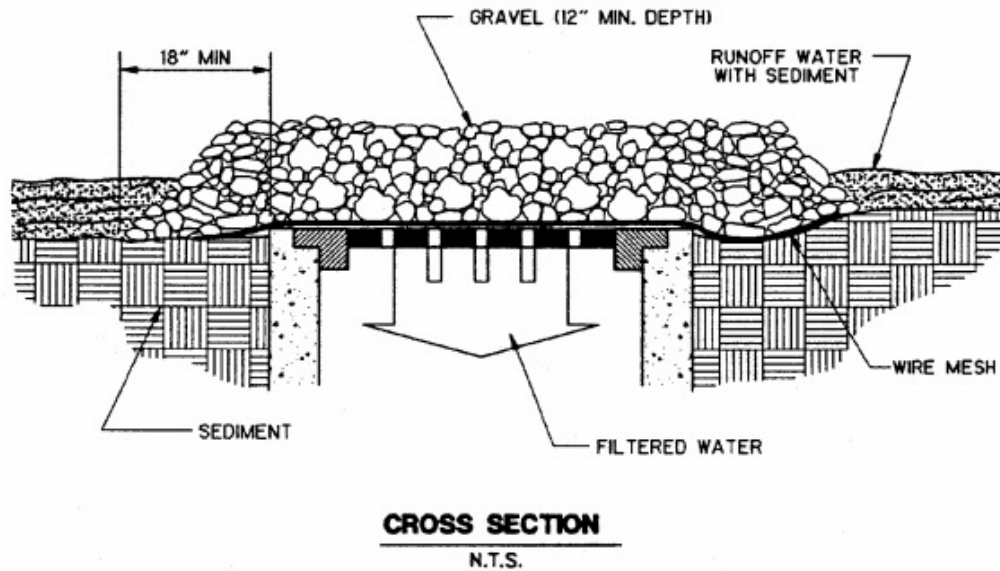

Figure 1-34 Wire Mesh and Gravel Inlet Protection (NCTCOG, 1993)

- (2) Coarse aggregate should be placed over the wire mesh as indicated in Figure 1-34. The depth of stone should be at least 12 inches over the entire inlet opening. The stone should extend beyond the inlet opening at least 18 inches on all sides.
- (3) If the stone filter becomes clogged with sediment so that it no longer adequately performs its function, the stones must be pulled away from the inlet, cleaned and/or replaced.

Concrete Washout Areas

The purpose of concrete washout areas is to prevent or reduce the discharge of pollutants to stormwater from concrete waste by conducting washout offsite, performing onsite washout in a designated area, and training employees and subcontractors.

The following steps will help reduce stormwater pollution from concrete wastes:

- Incorporate requirements for concrete waste management into material supplier and subcontractor agreements.
- Avoid mixing excess amounts of fresh concrete.
- Perform washout of concrete trucks in designated areas only.
- Do not wash out concrete trucks into storm drains, open ditches, streets, or streams.
- Do not allow excess concrete to be dumped onsite, except in designated areas.

For onsite washout:

- Locate washout area at least 50 feet from sensitive features, storm drains, open ditches, or water bodies. Do not allow runoff from this area by constructing a temporary pit or bermed area large enough for liquid and solid waste.
- Wash out wastes into the temporary pit where the concrete can set, be broken up, and then disposed properly.

TEMPORARY STORMWATER SECTION

Below grade concrete washout facilities are typical. These consist of a lined excavation sufficiently large to hold expected volume of washout material. Above grade facilities are used if excavation is not practical. Temporary concrete washout facility (type above grade) should be constructed as shown on the details at the end of this section, with sufficient quantity and volume to contain all liquid and concrete waste generated by washout operations. Plastic lining material should be a minimum of 10 mil in polyethylene sheeting and should be free of holes, tears, or other defects that compromise the impermeability of the material. When temporary concrete washout facilities are no longer required for the work, the hardened concrete should be removed and disposed of. Materials used to construct temporary concrete washout facilities should be removed from the site of the work and disposed of. Holes, depressions or other ground disturbance caused by the removal of the temporary concrete washout facilities should be backfilled and repaired.

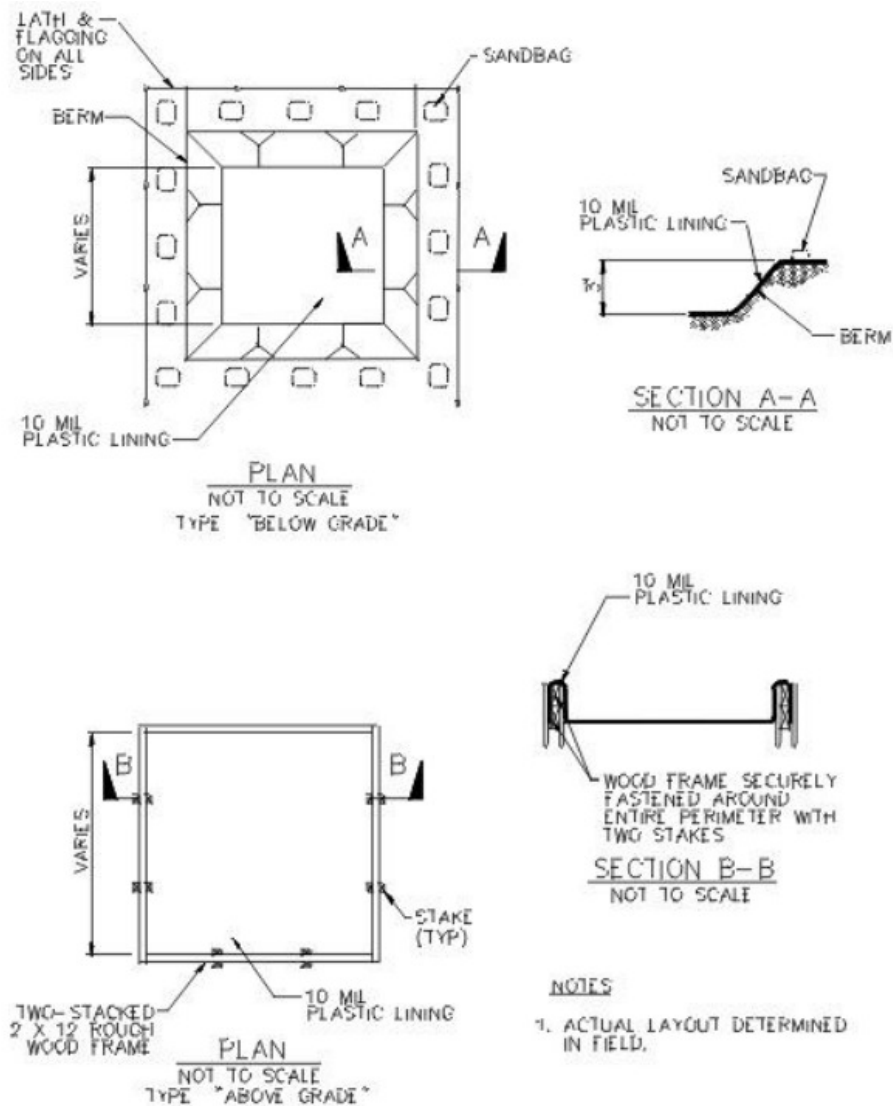

Figure 1-43 Schematics of Concrete Washout Areas

TEMPORARY STORMWATER SECTION

ATTACHMENT G

Drainage Area Map.

See Drainage Area maps EX-2A & EX-2B attached after this sheet.

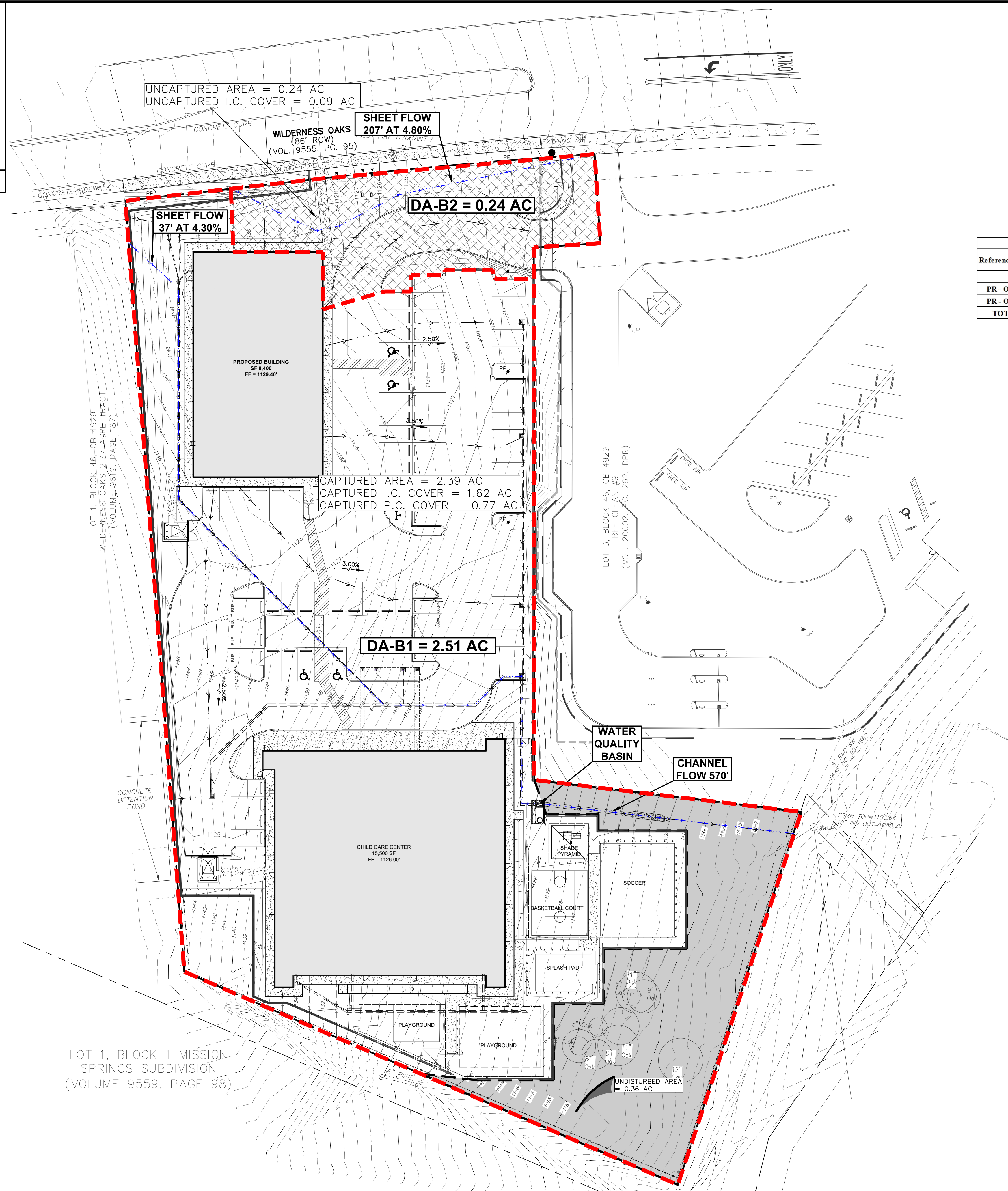
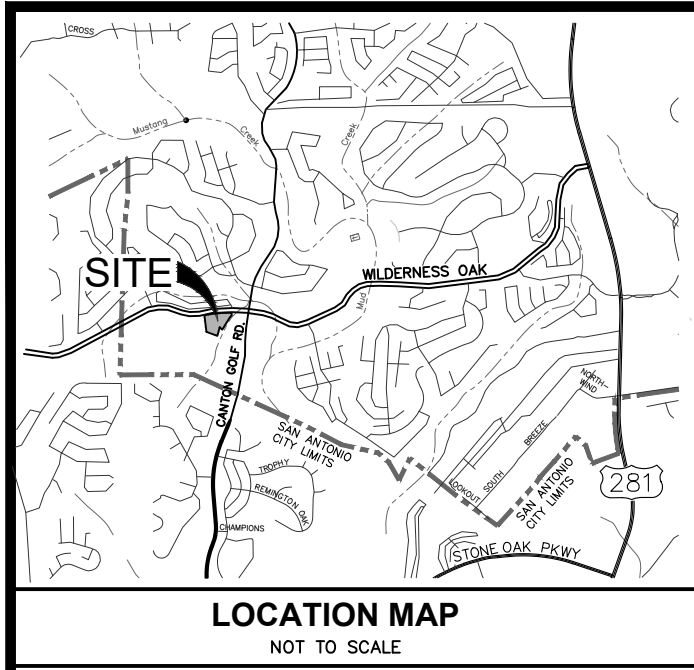

RUNOFF FLOW RATES PA-2

Reference Point	Drainage Areas	C	Drainage Area (ac)	Tc (min)	I _s (in/hr)	I ₂₅ (in/hr)	I ₁₀₀ (in/hr)	Q _s (cfs)	Q ₂₅ (cfs)	Q ₁₀₀ (cfs)
PR - Onsite	B1	0.81	2.51	7	7.17	10.03	12.69	14.58	20.39	25.80
PR - Onsite	B2	0.73	0.24	10	6.36	8.88	11.23	1.11	1.56	1.97
TOTAL			2.75					15.69	21.95	27.77

LEGEND

EXISTING	PROPOSED	DESCRIPTION
-678-	-678-	CONTOUR
	→	FLOW ARROW
	▨	UNCAPTURED AREA
	▩	RETAINING WALL
	▩	UNDISTURBED AREA

TEMPORARY BMP'S LEGEND

PROPOSED	DESCRIPTION
— SF —	SILT FENCE
▨	CONSTRUCTION ENTRANCE/EXIT
— IP —	INLET PROTECTION
▨	CONCRETE WASHOUT PIT

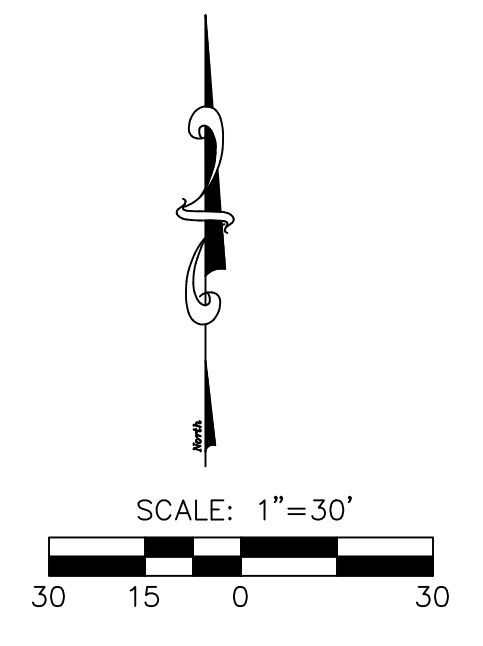

K LOVE ENGINEERING
 Site Development Engineering Services
 Firm No. 11042
 www.kloveengineering.com (210) 485-5683

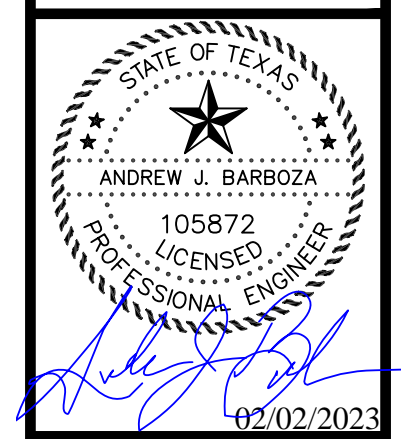

DATE: _____

REVISIONS:

NO.	DATE	DESCRIPTION

OWNER:
 AZEA HOLDINGS, LLC
 11010 COACHLIGHT ST., STE 101
 SAN ANTONIO, TEXAS 78216

IVY KIDS OF STONE OAK
 24272 WILDERNESS OAK (SHOPPING CENTER)
 24278 WILDERNESS OAK (CHILD CARE CENTER)
 SAN ANTONIO, TEXAS 78258

PROPOSED DRAINAGE AREA MAP

DESIGNED BY: AJB
 DRAWN BY: RQ
 SCALE: 1" = 30"
 DATE: 09/26/22
 SHEET NO: **EX-2B**

Texas Commission on Environmental Quality
Water Pollution Abatement Plan
General Construction Notes

- A written notice of construction must be submitted to the TCEQ regional office at least 48 hours prior to the start of any regulated activities. This notice must include:
 - The name of the approved project
 - The activity start date; and
 - The contractor information of the primer contractor.
- All contractors conducting regulated activities associated with this project must be provided with complete copies of the approved Water Pollution Abatement Plan (WPAP) and the TCEQ letter indicating the specific conditions of its approval. During the course of these regulated activities, the contractors are required to keep on-site copies of the approved plan and approval letter.
- If any sensitive feature(s) (caves, solution cavity, sink hole, etc.) is discovered during construction, all regulated activities near the sensitive feature must be suspended immediately. The appropriate TCEQ regional office must be immediately notified of any sensitive features encountered during construction. Construction activities may not be resumed until the TCEQ has reviewed and approved the appropriate protective measures in order to protect any sensitive feature and the Edwards Aquifer from potentially adverse impacts to water quality.
- No temporary or permanent hazardous substance storage tank shall be installed within 150 feet of water supply source, distribution system, well, or sensitive feature.
- Prior to beginning any construction activity, all temporary erosion and sedimentation (E&S) control measures must be properly installed and maintained in accordance with the approved plans and manufacturers specifications. If inspections indicate a control has been used inappropriately, or incorrectly, the applicant must replace or modify the control for site situations. These controls must remain in place until the disturbed areas have been permanently stabilized.
- Any sediment that escapes the construction site must be collected and properly disposed of before the next rain event to ensure it is not washed into surface streams, sensitive features, etc.
- Sediment must be removed from the sediment traps or sedimentation basins not later than when it occupies 50% of the basin's design capacity.
- Litter, construction debris, and construction chemicals exposed to stormwater shall be prevented from being discharged offsite.
- All spoils (excavated material) generated from the project site must be stored on-site with proper E&S controls. For storage or disposal of spoils at another site on the Edwards Aquifer Recharge Zone, the owner of the site must receive approval of a water pollution abatement plan for the placement of fill material or mass grading prior to the placement of spoils at the other site.
- If portions of the site will have temporary or permanent cease in construction activity lasting longer than 14 days, soil stabilization in those areas shall be initiated as soon as possible prior to the 14th day of inactivity. If activity will resume prior to the 21st day, stabilization measures are not required. If drought conditions or inclement weather prevent action by the 14th day, stabilization measures shall be initiated as soon as possible.
- The following records shall be maintained and made available to the TCEQ upon request:
 - the dates when major grading activities occur;
 - the dates when construction activities temporarily or permanently cease on a portion of the site; and
 - the dates when stabilization measures are initiated.
- The holder of any approved Edwards Aquifer protection plan must notify the appropriate regional office in writing and obtain approval from the executive director prior to initiating any of the following:
 - A. any physical or operational modification of any water pollution abatement structure(s), including but not limited to ponds, dams, berms, sewage treatment plants, and diversionary structures;
 - B. any change in the nature or character of the regulated activity from that which was originally approved or a change which would significantly impact the ability of the plan to prevent pollution of the Edwards Aquifer;
 - C. any development of land previously identified as undeveloped in the original water pollution abatement plan.

Austin Regional Office
 12100 Park 35 Circle, Building A
 Austin, Texas 78753-1808
 Phone (512) 339-2929
 Fax (512) 339-3795

San Antonio Regional Office
 14250 Judson Road
 San Antonio, Texas 78233-4480
 Phone (210) 490-3096
 Fax (210) 545-4329

THESE GENERAL CONSTRUCTION NOTES MUST BE INCLUDED ON THE CONSTRUCTION PLANS PROVIDED TO THE CONTRACTOR AND ALL SUBCONTRACTORS.

THE LOCATION OF EXISTING UNDERGROUND UTILITIES ARE SHOWN IN AN APPROXIMATE WAY ONLY. THE CONTRACTOR SHALL DETERMINE THE EXACT LOCATION OF ALL EXISTING UTILITIES BEFORE COMMENCING WORK. HE AGREES TO BE FULLY RESPONSIBLE FOR ANY AND ALL DAMAGES WHICH MIGHT OCCUR BY HIS FAILURE TO EXACTLY LOCATE AND PRESERVE ANY AND ALL UNDERGROUND UTILITIES.

Date: Feb 02, 2024, 1:07pm
 File: K:\PROJECTS\13183-CD-ivy kids dividers\TCEQ\WPAP\13183-CD-ivy kids dividers\Stormwater Section\EX-2B WPAP RQ29-04.dwg



TEMPORARY STORMWATER SECTION

ATTACHMENT H

Temporary Sediment Pond(s) Plans and Calculations

N/A.

TEMPORARY STORMWATER SECTION

ATTACHMENT I

Inspections and Maintenance for BMPs

The designated and qualified person(s) shall inspect the Pollution Control Measures weekly and within 24 hours after a storm event. A report that summarizes the inspections scope, name and qualification of person(s) conducting the inspection, date of inspection, any actions taken as a result of inspection, and observations shall be recorded and maintained for a period of three years after the date of the inspection as part of the Storm Water TPDES data. A copy of the Inspection Report Form is provided in this Storm Water Pollution Prevention Plan.

The inspector shall observe the following as a minimum:

1. Significant disturbed areas for evidence of erosion
2. Storage areas for evidence of leakage from the exposed stored materials
3. Structural controls for evidence of failure or excess siltation
 - a. Rock berms
 - b. Silt fences
 - c. Drainage swales
 - d. Inlet protection
 - e. Sediment over 6 inches
 - f. Outlet structures (ponds or basins outfalls)
4. Construction entrance/exit for evidence of off-site sediment tracking
5. Construction staging areas for evidence of vehicle leakage or spills
6. Concrete truck washout pit for signs of failure
7. Basin erosion or sediment buildup

Any deficiencies noted during the inspection will be corrected and documented within seven (7) calendar days following the inspection or before the next anticipated storm event.

Contractor shall review Sections 1.3 and 1.4 of the TCEQ Technical Guidance Manual for any additional BMP maintenance and inspection requirements.

TEMPORARY STORMWATER SECTION

Pollution Prevention Measure	Inspected	Corrective Action	
		Description	Date Completed
Revegetation			
Erosion/sediment controls			
Construction exits			
Construction staging areas			
Concrete washout pit			
Construction debris/litter			
Trash receptacles			
Infrastructure			
Roadway clearing			
Utility clearing			
Roadway grading			
Utility construction			
Drainage construction			
Roadway base			
Roadway surface			
Pad clearing			
Pad grading			
Foundation construction			
Building construction			
Site grading			
Site cleanup			
BMPs			
Other Measures			

By my signature below, I certify that all items are acceptable and the project site is in compliance with the SWPPP.

Inspector's Name

Inspector's Signature

Name of Owner/Operator (Firm)

Date

*Inspector to attach statement of qualifications to this report.



TEMPORARY STORMWATER SECTION

PROJECT DATES AND ACTIVITIES

Date and description when major site grading occurs

<u>Construction Activity</u>	<u>Date</u>
_____	_____
_____	_____
_____	_____
_____	_____
_____	_____
_____	_____
_____	_____
_____	_____

Date and description when construction activities temporarily or permanently cease

<u>Construction Activity</u>	<u>Date</u>
_____	_____
_____	_____
_____	_____
_____	_____
_____	_____
_____	_____
_____	_____
_____	_____

Date and description of stabilization measures used

<u>Stabilization Activity</u>	<u>Date</u>
_____	_____
_____	_____
_____	_____
_____	_____
_____	_____
_____	_____
_____	_____
_____	_____

TEMPORARY STORMWATER SECTION

ATTACHMENT J

Schedule of Interim and Permanent Soil Stabilization

During construction, existing vegetation shall be protected as much as possible.

Soil stabilization shall commence when construction activities have ceased for that area.

Permanent Stabilization

- All slopes for the site shall not exceed a slope of 3:1 to allow for vegetation to be established without extra support or matting. Stabilization will occur when construction activities have been completed and will not resume.
- Areas within islands and curbs shall be re-vegetated in accordance to the landscaping plan. Re-vegetation will occur when described in the landscaping plan or when vegetation will not be harmed from future construction activities.

Natural Vegetation

Materials

- Vegetation will vary from season to season and by location. Consult the county agricultural extension agents for specific seeds and application rates.

Installation

- Final grading and all erosion structures must be completed before seeding is to occur.
- Seedbed should be well pulverized, loose, and uniform.
- Fertilizer will be applied at a rate of 40 pounds of nitrogen and 40 pounds of phosphorus per acre. A substitute for fertilizer will be compost applied at the same time as seeding.
- Apply seeding with a cyclone seeder, cultipacker seeder, drill, or hydroseeder.
- Irrigate as to replace moisture loss due to evaporation.

Blankets and Matting

Materials

- Not limited to, jute, excelsior, straw blanket, wood fiber blanket, coconut fiber blanket-mesh, straw coconut fiber blanket, plastic netting-mesh, synthetic fiber with netting or bonded synthetic fibers may be used. Other materials may be used if approved by the engineer.

Installation

- Install in accordance with the manufacturer's recommendations and ensure proper anchoring and soil preparation. Methods and materials for anchoring may vary and should follow manufacturer's instructions.

TEMPORARY STORMWATER SECTION

Hydraulic Mulch

Materials

- Hydraulic mulches to consist of wood fiber mulch to be applied at a rate of 2,000 to 4,000 pounds per acre.
- Hydraulic matrices to consists of wood fibers and acrylic polymer or similar binder applied at a rate of 2,000 to 4,000 pounds per acre for wood fiber mulch and 5 to 10 percent of binder.
- Bonded fiber matrix to consists of wood fibers and adhesives applied at a rate of 3,000 to 4,000 pounds per acre.

Installation

- Prior to application, disturbed areas shall be roughened by rolling with crimping or punching type roller or by track walking when rolling is impractical.
- Place hydraulic matrices as to allow 24 hours to dry before rainfall occurs.

Sod

Materials

- Sod should be machine cut at a uniform soil thickness of 3/4 inch which excludes shoot growth and thatch. Pieces should be cut to a uniform width and length, torn or uneven pads should not be used. Sod should be harvested, delivered, and installed within a period of 36 hours.

Installation

- Fertilizer shall be placed prior to placement of the sod. Rates and types of fertilizer shall be placed in accordance with an soil tests or recommendations by the county agricultural agents.
- Do not place sod on frozen surfaces or excessively wet or dry weather. Irrigation may be necessary prior to placement of sod.
- Place the first row of sod in a straight line with following rows placed parallel and butting against the prior row. Joints should be staggered to promote uniform growth and strength. Do not stretch or overlap sod.
- On slopes 3:1 or greater, stagger joints and secure with stapling or other approved method. Install sod with the length perpendicular to the slope.
- After placement of sod, roll or tamp the sod to ensure firm contact between roots and soil.
- After rolling or tamping, irrigate sod to a depth sufficient that the underside of the pad and 4 inches of soil below is thoroughly wet.
- In the absence of adequate rainfall, watering shall be performed to maintain a moist soil depth of at least 4 inches.
- The first mowing should not occur until the sod is firmly rooted, approximately 2 to 3 weeks.

SECTION 6

PERMANENT STORMWATER

Permanent Stormwater Section

Texas Commission on Environmental Quality

for Regulated Activities on the Edwards Aquifer Recharge Zone and Relating to 30 TAC §213.5(b)(4)(C), (D)(ii), (E), and (5), Effective June 1, 1999

To ensure that the application is administratively complete, confirm that all fields in the form are complete, verify that all requested information is provided, consistently reference the same site and contact person in all forms in the application, and ensure forms are signed by the appropriate party.

Note: Including all the information requested in the form and attachments contributes to more streamlined technical reviews.

Signature

To the best of my knowledge, the responses to this form accurately reflect all information requested concerning the proposed regulated activities and methods to protect the Edwards Aquifer. This **Permanent Stormwater Section** is hereby submitted for TCEQ review and executive director approval. The application was prepared by:

Print Name of Customer/Agent: Andrew J. Barboza, P.E.

Date: 12/19/2022

Signature of Customer/Agent

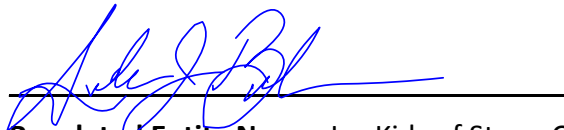

Regulated Entity Name: Ivy Kids of Stone Oak

Permanent Best Management Practices (BMPs)

Permanent best management practices and measures that will be used during and after construction is completed.

- Permanent BMPs and measures must be implemented to control the discharge of pollution from regulated activities after the completion of construction.
 N/A
- These practices and measures have been designed, and will be constructed, operated, and maintained to insure that 80% of the incremental increase in the annual mass loading of total suspended solids (TSS) from the site caused by the regulated activity is removed. These quantities have been calculated in accordance with technical guidance prepared or accepted by the executive director.
 The TCEQ Technical Guidance Manual (TGM) was used to design permanent BMPs and measures for this site.

A technical guidance other than the TCEQ TGM was used to design permanent BMPs and measures for this site. The complete citation for the technical guidance that was used is: _____

N/A

3. Owners must insure that permanent BMPs and measures are constructed and function as designed. A Texas Licensed Professional Engineer must certify in writing that the permanent BMPs or measures were constructed as designed. The certification letter must be submitted to the appropriate regional office within 30 days of site completion.

N/A

4. Where a site is used for low density single-family residential development and has 20 % or less impervious cover, other permanent BMPs are not required. This exemption from permanent BMPs must be recorded in the county deed records, with a notice that if the percent impervious cover increases above 20% or land use changes, the exemption for the whole site as described in the property boundaries required by 30 TAC §213.4(g) (relating to Application Processing and Approval), may no longer apply and the property owner must notify the appropriate regional office of these changes.

The site will be used for low density single-family residential development and has 20% or less impervious cover.

The site will be used for low density single-family residential development but has more than 20% impervious cover.

The site will not be used for low density single-family residential development.

5. The executive director may waive the requirement for other permanent BMPs for multi-family residential developments, schools, or small business sites where 20% or less impervious cover is used at the site. This exemption from permanent BMPs must be recorded in the county deed records, with a notice that if the percent impervious cover increases above 20% or land use changes, the exemption for the whole site as described in the property boundaries required by 30 TAC §213.4(g) (relating to Application Processing and Approval), may no longer apply and the property owner must notify the appropriate regional office of these changes.

Attachment A - 20% or Less Impervious Cover Waiver. The site will be used for multi-family residential developments, schools, or small business sites and has 20% or less impervious cover. A request to waive the requirements for other permanent BMPs and measures is attached.

The site will be used for multi-family residential developments, schools, or small business sites but has more than 20% impervious cover.

The site will not be used for multi-family residential developments, schools, or small business sites.

6. **Attachment B - BMPs for Upgradient Stormwater.**

- A description of the BMPs and measures that will be used to prevent pollution of surface water, groundwater, or stormwater that originates upgradient from the site and flows across the site is attached.
 - No surface water, groundwater or stormwater originates upgradient from the site and flows across the site, and an explanation is attached.
 - Permanent BMPs or measures are not required to prevent pollution of surface water, groundwater, or stormwater that originates upgradient from the site and flows across the site, and an explanation is attached.
7. **Attachment C - BMPs for On-site Stormwater.**
- A description of the BMPs and measures that will be used to prevent pollution of surface water or groundwater that originates on-site or flows off the site, including pollution caused by contaminated stormwater runoff from the site is attached.
 - Permanent BMPs or measures are not required to prevent pollution of surface water or groundwater that originates on-site or flows off the site, including pollution caused by contaminated stormwater runoff, and an explanation is attached.
8. **Attachment D - BMPs for Surface Streams.** A description of the BMPs and measures that prevent pollutants from entering surface streams, sensitive features, or the aquifer is attached. Each feature identified in the Geologic Assessment as sensitive has been addressed.
- N/A
9. The applicant understands that to the extent practicable, BMPs and measures must maintain flow to naturally occurring sensitive features identified in either the geologic assessment, executive director review, or during excavation, blasting, or construction.
- The permanent sealing of or diversion of flow from a naturally-occurring sensitive feature that accepts recharge to the Edwards Aquifer as a permanent pollution abatement measure has not been proposed.
 - Attachment E - Request to Seal Features.** A request to seal a naturally-occurring sensitive feature, that includes, for each feature, a justification as to why no reasonable and practicable alternative exists, is attached.
10. **Attachment F - Construction Plans.** All construction plans and design calculations for the proposed permanent BMP(s) and measures have been prepared by or under the direct supervision of a Texas Licensed Professional Engineer, and are signed, sealed, and dated. The plans are attached and, if applicable include:
- Design calculations (TSS removal calculations)
 - TCEQ construction notes
 - All geologic features
 - All proposed structural BMP(s) plans and specifications
- N/A

11. **Attachment G - Inspection, Maintenance, Repair and Retrofit Plan.** A plan for the inspection, maintenance, repairs, and, if necessary, retrofit of the permanent BMPs and measures is attached. The plan includes all of the following:
- Prepared and certified by the engineer designing the permanent BMPs and measures
 - Signed by the owner or responsible party
 - Procedures for documenting inspections, maintenance, repairs, and, if necessary retrofit
 - A discussion of record keeping procedures
- N/A
12. **Attachment H - Pilot-Scale Field Testing Plan.** Pilot studies for BMPs that are not recognized by the Executive Director require prior approval from the TCEQ. A plan for pilot-scale field testing is attached.
- N/A
13. **Attachment I - Measures for Minimizing Surface Stream Contamination.** A description of the measures that will be used to avoid or minimize surface stream contamination and changes in the way in which water enters a stream as a result of the construction and development is attached. The measures address increased stream flashing, the creation of stronger flows and in-stream velocities, and other in-stream effects caused by the regulated activity, which increase erosion that results in water quality degradation.
- N/A

Responsibility for Maintenance of Permanent BMP(s)

Responsibility for maintenance of best management practices and measures after construction is complete.

14. The applicant is responsible for maintaining the permanent BMPs after construction until such time as the maintenance obligation is either assumed in writing by another entity having ownership or control of the property (such as without limitation, an owner's association, a new property owner or lessee, a district, or municipality) or the ownership of the property is transferred to the entity. Such entity shall then be responsible for maintenance until another entity assumes such obligations in writing or ownership is transferred.
- N/A
15. A copy of the transfer of responsibility must be filed with the executive director at the appropriate regional office within 30 days of the transfer if the site is for use as a multiple single-family residential development, a multi-family residential development, or a non-residential development such as commercial, industrial, institutional, schools, and other sites where regulated activities occur.
- N/A

PERMANENT STORMWATER SECTION

ATTACHMENT A

20% or Less Impervious Cover Waiver

This site will be used for a small business but will have an impervious cover value greater than 20%.

PERMANENT STORMWATER SECTION

ATTACHMENT B

BMPs for Upgradient Stormwater

The project site currently receives no upgradient stormwater runoff. No upgradient runoff will be routed through the subject tract and treated by the onsite Up-Flo Filter (Hydro International) Treatment System.

PERMANENT STORMWATER SECTION

ATTACHMENT C

BMPs for On-Site Stormwater

In keeping with TCEQ rules, this development will employ an Up-Flo Filter system by Hydro International. The Best Management Practice used, the Up-Flo Filter system, for the project should achieve at least 78% reduction in the expected increase of suspended solids.

PERMANENT STORMWATER SECTION

ATTACHMENT C-1

Technical Abstract Up-Flo Filter CPZ – TCEQ Sizing

Texas Commission of Environmental Quality - Edwards Aquifer Sizing to RG-348

The Up-Flo[®] Filter with CPZ media is approved by the Texas Commission on Environmental Quality (TCEQ) for use within the Edwards Aquifer recharge zone.

Complying with the Edwards Aquifer Rules: Technical Guidance on Best Management Practices, known as RG-348, provides detailed descriptions and examples of the process used to calculate the mass of Total Suspended Solids (TSS) load resulting from any increase in impervious area that a development may create. This increase in load is then mitigated through the use of approved Best Management Practices (BMPs) that must remove 80% of the net increase in TSS load. To simplify the calculation TCEQ developed a spreadsheet that standardizes the calculation for each BMP. This Technical Abstract refers to RG-348 and to the TCEQ approved Up-Flo[®] Filter sizing spreadsheet available from Hydro International.

Section 3.3 of RG-348 states: "Under 30 TAC Chapter 213, 80% of the increase in TSS load resulting from development (over background) must be removed."

The following steps are used to calculate the load and size the BMP:

- (1) Calculate the required TSS (load) removal, which is based on the net increase in impervious acres
- (2) Select a BMP or combination of BMPs
- (3) Calculate the TSS load removal by each BMP
- (4) Calculate the percentage of runoff that must be treated to achieve the 80% removal (total load reduction)
- (5) Adjust the size or type of BMP(s) to ensure load removed is equal to or exceeds the load increase

It is important to understand that RG-348 uses a total load reduction model. The BMP must be sized to remove a mass of material based on the volume of water treated. It does not require a BMP to be 80% efficient to meet the treatment goal.

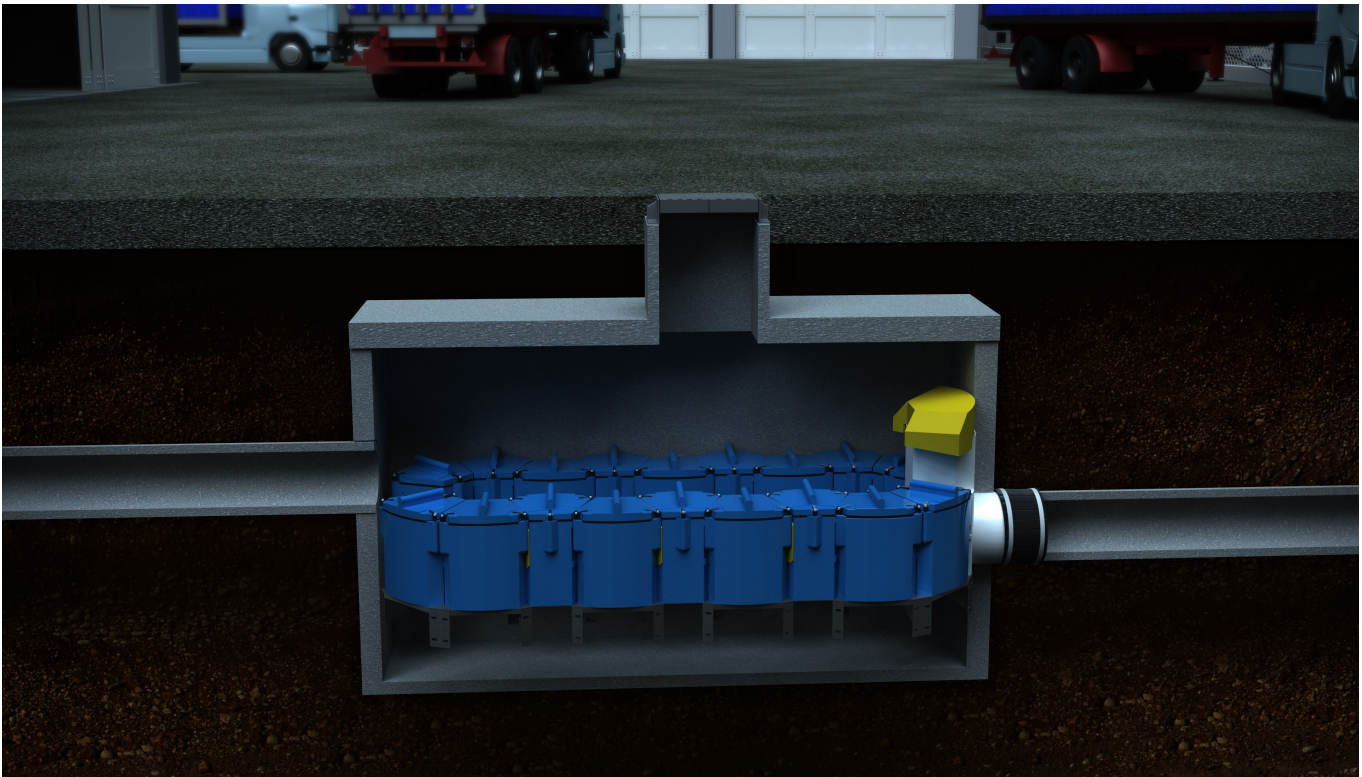

Calculation Equations:

- The required TSS load reduction is calculated using the Equation 3.2:

$$L_M = (0.8 \times 0.226) \times (A_N \times P \times 0.9 \times 170 \text{ mg/L} - A_N \times 0.03 \times 80 \text{ mg/L})$$

Where:

L_M	= Required load reduction (pounds)
A_N	= Net increase in impervious area (acres)
P	= Average annual precipitation (inches)
0.8	= 80% reduction factor
170	= TSS concentration from impervious area (mg/L)
80	= TSS concentration from pervious area (mg/L)
0.9	= Runoff coefficient for impervious area
0.03	= Runoff coefficient for pervious area
0.226	= Unit conversion factor

This equation simplifies to Equation 3.3:

$$L_M = 27.2(A_N \times P)$$

- The required load reduction is calculated using the Equation 3.7:

$$L_R = (\text{BMP efficiency}) \times 0.226 \times P \times (A_I \times 0.9 \times 170 \text{ mg/L} + A_P \times 0.03 \times 80 \text{ mg/L})$$

Where:

L_R	= Load removed by BMP (pounds)
BMP eff	= TSS Removal efficiency of selected BMP
P	= Average annual precipitation (inches)
A_I	= Impervious tributary area (acres)
A_P	= Pervious tributary area (acres)
170	= TSS concentration from impervious area (mg/L)
80	= TSS concentration from pervious area (mg/L)
0.9	= Runoff coefficient for impervious area
0.03	= Runoff coefficient for pervious area
0.226	= Unit conversion factor

This equation simplifies to Equation 3.8:

$$L_R = (\text{BMP efficiency}) \times P \times (A_I \times 34.6 + A_P \times 0.54)$$

- The fraction of rainfall treated is calculated using the Equation 3.9

$$F = L_M / L_R$$

Where:

F	= Fraction of annual rainfall treated
L_M	= Required load reduction (80% of the net increase in TSS Load)
L_R	= Load removal for each BMP summed

The value of F must be less than 1 otherwise insufficient water is being treated to achieve the required load reduction. In other words, the BMP must be capable of treating more runoff than would occur in the average year to achieve the load reduction. If the number is greater than 1 the BMP is not able to treat the required runoff and must be made larger or another BMP employed in a treatment train.

It is important to understand that this is a load (mass) reduction model and that the BMP(s) must remove a mass of material and can be assigned an individual BMP TSS efficiency of less than or more than 80%. The BMP size is controlled by the mass capture capacity of the BMP(s) so that the total mass removed is greater than the net increase in TSS from the development calculated in Equation 3.2 and that the fraction of rainfall treated as calculated in Equation 3.9 is less than 1.

Up-Flo® Filter Mass Load Capacity

The Up-Flo® Filter has been independently field tested and approved by TCEQ based on this field testing. The average TSS concentration reduction was 78% with a flow weighted flow weighted mass balance TSS reduction of 88%. The Up-Flo® Filter can remove 132 lb of TSS load per filter module.

Up-Flo® Filter Sizing Using TCEQ Approved Spreadsheet

The BMP efficiency controls the load reduction initially assigned to the BMP based on the total net increase in TSS load. The BMP does not need to have an assigned TSS efficiency reduction of 80% or greater to meet the required TSS load reduction. There is a difference between the TSS efficiency and the TSS Load Reduction capacity of the filter. TCEQ assigns the filter efficiency based on the average TSS concentration reduction for the qualifying monitored storms in the test.

Access Online: <https://designtools.hydro-int.com/home>

Example Calculation

Area: 5 ac
 Predevelopment Impervious: 1 ac
 Post-Development Impervious: 4 ac
 Net Increase in Impervious: 3 ac (going to new BMP)
 No offsite areas draining to the site.
 Williamson County

Steps 1 & 2: Site and Drainage Basin Details

Step 1 and 2 show identical TSS loads (L_M) as only a single drainage basin is being considered. If the site has multiple drainage basins Step 2 - 7 will need to be replicated for each drainage basin.

1. The Required Load Reduction for the Total Project.

Calculations from RG-348, Pages 3-27 to 3-30

Page 3-29 Equation 3.3:

$$L_M = 27.2(A_N \times P)$$

Where:

$L_{M \text{ TOTAL PROJECT}}$ = Required TSS removal resulting from the proposed development = 80% of increased load

A_N = Net increase in impervious area for the project

P = Average annual precipitation, inches

Site Data: Determine Required Load Removal Based on the Entire Project

County =	Williamson	
Total project area included in plan =	3.00	acres
Predevelopment impervious area within the limits of the plan =	0.00	acres
Total post-development impervious area within the limits of the plan =	2.00	acres
Total post-development impervious cover fraction =	0.67	
P =	32	inches
$L_{M \text{ TOTAL PROJECT}}$ =	1741	lb
Number of drainage basins / outfalls areas leaving the plan area =	1	

2. Drainage Basin Parameters (This information should be provided for each basin).

Drainage Basin/Outfall Area No. =	1	
Total drainage basin/outfall area =	3.00	acres
Predevelopment impervious area within drainage basin/outfall area =	0.00	acres
Post-development impervious area within drainage basin/outfall area =	2.00	acres
Post-development impervious fraction within drainage basin/outfall area =	0.67	
$L_{M \text{ THIS BASIN}}$ =	1,741	lb

Step 3: Up-Flo® Filter Efficiency

The Up-Flo® Filter has been assessed to have a TSS concentration reduction efficiency of 78%. This is found in Step 3 of the design spreadsheet and should not be altered, but in some sites may require additional filter modules to be installed to achieve the required total load reduction.

Adding additional filter modules also increases the total flow the filter can treat, which has the added benefit of reducing the required Water Quality Capture Volume in Step 6.

3. Indicate the Proposed BMP Code for this Basin.

Proposed BMP = **Up-Flo® Filter CPZ**
Removal efficiency = **78** percent

Step 4: Up-Flo® Filter Mass Removal

Step 4 calculates the Up-Flo® Filter's TSS mass removal (L_R) based on the 78% efficiency rating. In the example, L_M calculated in Step 2 = 1741 lb and L_R calculated in Step 4 is also = 1741 lb. This is because the 2% difference for 80% TSS load reduction is within the rounding error of the calculation for small drainage basins.

4. Calculate Maximum TSS Load Removed (L_R) for this Drainage Basin by the Selected BMP Type.

RG-348 Page 3-33 Equation 3.7:

$$L_R = (\text{BMP efficiency}) \times P \times (A_I \times 34.6 + A_P \times 0.54)$$

Where:

A_C = Total On-Site drainage area in the BMP catchment area

A_I = Impervious area proposed in the BMP catchment area

A_P = Pervious area remaining in the BMP catchment area

L_R = TSS Load removed from this catchment area by the proposed BMP

A_C =	3.00	acres
A_I =	2.00	acres
A_P =	1.00	acres
L_R =	1,741	lb

Step 5: Fraction of Annual Rainfall Treated

Step 5 calculates the fraction (F) of water treated on an annual basis using Equation 3.9, $F = L_R / L_M$, which must be less than 1.

Any small differences in L_M and L_R at this point show in F . Note the user must manually input the value of L_M in Step 5 as it is possible that the designer is splitting the treatment between two or more BMPs and is putting less load into this BMP.

5. Calculate Fraction of Annual Runoff to Treat the Drainage Basin / Outfall Area.

Note

Desired L_M THIS BASIN = **1,741** lb
 F = **1.00**

Changing the Site's TSS Removal Target for values other than 80% Load Reduction

The Up-Flo® Filter can be used for TSS removals for more or less than the standard 80% TSS for a site. This can be achieved in Step 5 by using the following procedure developed by TCEQ.

First calculate the ratio between 80% and the desired TSS reduction using the formula $X / 80$ where X is the desired TSS reduction.

Multiply L_M in Step 2 by this ratio to get a new value for L_M and enter that value in Step 5.

Example: For 85% TSS the ratio is $85 / 80 = 1.06$

Multiply L_M in Step 2 by this value, $1741 \times 1.06 = 1850$ lb of TSS load removal is required for 85% TSS Load Reduction.

This value is then entered in Step 5. At this stage F will exceed 1 and the BMP size will need to be altered to reduce F to below 1 again. **This is done in Step 7.**

Step 6: Capture Volume

The Rainfall Depth, Post Development Runoff Coefficient, and On-Site Water Quality Volume are all values calculated by the spreadsheet. Any off-site water draining to the BMP should also be added in Step 6. Some of the Total Capture Volume is held within the Up-Flo® Filter chamber. Refer to Hydro International for this volume once the number of filter modules has been calculated to get a vault size.

The Rainfall Depth is related to the Fraction of Treated Rainfall (F). Refer to RG-348, Table 3-5. The smaller the value of F, the larger the BMP is relative to the site size and the less water is required to be captured. This is because the BMP is treating a greater amount of the runoff.

6. Calculate Capture Volume Required by the BMP Type for this Drainage Basin / Outfall Area.

Calculations from RG-348 Pages 3-34 to 3-36

Rainfall Depth =	4.00	inches
Post Development Runoff Coefficient =	0.47	
On-site Water Quality Volume =	20,651	cubic feet

Calculations from RG-348 Pages 3-36 to 3-37

Off-site area draining to BMP =	0.00	acres
Off-site Impervious cover draining to BMP =	0.00	acres
Impervious fraction of off-site area =	0	
Off-site Runoff Coefficient =	0.00	
Off-site Water Quality Volume =	0	cubic feet
Storage for Sediment =	4,130	cubic feet
Total Capture Volume (required water quality volume x 1.20) =	24,781	cubic feet

Step 7: Up-Flo® Filter Sizing

In Step 7 the spreadsheet calculates the minimum number of Filter modules required to treat for the TSS load L_R in Step 5, however due to the Filter's 78% efficiency rating the treated Rainfall Fraction in Step 5 may exceed 1. In this case additional filter modules can be added in Step 7a.

The spreadsheet then recalculates a new value for F and the Total Capture Volume based on this new F value. In some cases it may be cost effective to increase the number of filter modules to reduced the Water Capture Volume, balancing filter cost against storage volume cost.

Maximum Release Rate

Each Up-Flo® Filter Module runs at maximum filter rate at about 30 inches of head. To achieve the values in Step 7 and 7a, an operating head of 30 inches is required. If a lower head is required contact Hydro International for assistance. The Maximum Release Rate is the filtration rate for the filter as sized in Step 7.

7. Up-Flo® Filter TSS Load Based Sizing.

Minimum Filter Modules based on L_R =	13	modules
Maximum Release Rate =	0.74	cfs

7a. Additional Filter Modules to Increase Filter TSS Load Capacity:

Enter number of additional Modules =	1	modules
Total Number of Modules =	14	modules
Maximum Release Rate =	0.79	cfs
Annual TSS Load Capacity for Filter =	1,873	lb

Recalculated Capture Volume Required:

F =	0.93	
Rainfall Depth =	2.20	inches
On-site Water Quality Volume =	11,358	cubic feet
Off-site Water Quality Volume =	0	cubic feet
Storage for Sediment =	2,272	cubic feet
Total Capture Volume (required water quality volume x 1.20) =	13,629	cubic feet

PERMANENT STORMWATER SECTION

ATTACHMENT D

BMPs for Surface Streams

The site does not have surface streams or sensitive features within the boundaries of the site.

PERMANENT STORMWATER SECTION

ATTACHMENT E

Request to Seal Features

There are no naturally occurring sensitive features located within the boundaries of the lot to be developed, thus no request to seal features.

PERMANENT STORMWATER SECTION

ATTACHMENT F

Construction Plans

Refer to WPAP Site Plan in the WPAP application section for Construction Plan. Please see the attached Design calculations (TSS Removal Calculations) and Technical Abstract Up-Flo Filter CPZ – TCEQ Sizing after following sheet.

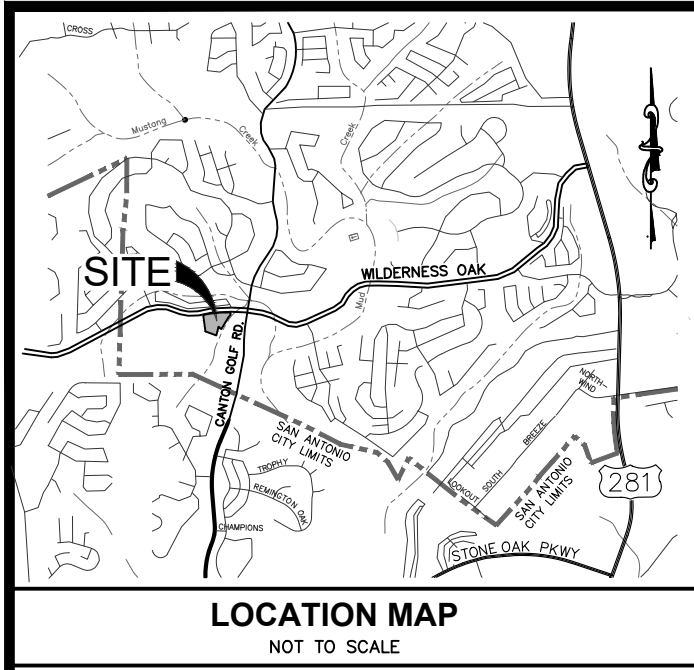

LOCATION MAP
NOT TO SCALE

TRENCH EXCAVATION SAFETY PROTECTION
 CONTRACTOR AND/OR CONTRACTOR'S INDEPENDENTLY RETAINED EMPLOYEE OR STRUCTURAL DESIGN/GEOTECHNICAL/SAFETY/EQUIPMENT CONSULTANT, IF ANY, SHALL REVIEW THESE PLANS AND AVAILABLE GEOTECHNICAL INFORMATION AND THE ANTICIPATED INSTALLATION SITE(S) WITHIN THE PROJECT AREA IN ORDER TO IMPLEMENT CONTRACTOR'S TRENCH EXCAVATION SAFETY PROTECTION SYSTEMS PROGRAMS AND/OR PROCEDURES. THE CONTRACTOR'S IMPLEMENTATION OF THE SYSTEM'S PROGRAMS AND/OR PROCEDURES SHALL PROVIDE FOR ADEQUATE TRENCH EXCAVATION SAFETY PROTECTION THAT COMPLIES WITH AS A MINIMUM, OSHA STANDARDS FOR TRENCH EXCAVATION. SPECIFICALLY, CONTRACTOR AND/OR CONTRACTOR'S INDEPENDENTLY RETAINED EMPLOYEE OR SAFETY CONSULTANT SHALL IMPLEMENT A TRENCH SAFETY PROGRAM IN ACCORDANCE WITH OSHA STANDARDS GOVERNING THE PRESENCE AND ACTIVITIES OF INDIVIDUALS WORKING IN AND AROUND TRENCH EXCAVATION.

BENCHMARKS

TBM#1: MAGNOL ON EXISTING CONCRETE, LOCATED APPROX. 12' NORTH OF NORTHEAST PROPERTY CORNER ALONG WILDERNESS OAKS
 ELEVATION = 1135.76'

KEY NOTES

1. TIE INTO 12" HEADER SYSTEM; INV. ELEV. = 1125.56'
2. TIE INTO 12" HEADER SYSTEM; INV. ELEV. = 1125.31'
3. TIE INTO 12" HEADER SYSTEM; INV. ELEV. = 1124.91'
4. TIE INTO 12" HEADER SYSTEM; INV. ELEV. = 1124.60'
5. 12" HDPE 1/2 BEND; INV. ELEV. = 1124.37'
6. TIE INTO 18" HEADER SYSTEM WITH WYE; INV. ELEV. = 1121.07'
7. 12" HDPE 1/2 BEND; INV. ELEV. = 1121.27'
8. TIE INTO 12" HEADER SYSTEM; INV. ELEV. = 1121.25'
9. TIE INTO 12" HEADER SYSTEM; INV. ELEV. = 1121.05'
10. TIE INTO 12" HEADER SYSTEM; INV. ELEV. = 1120.90'
11. 12" HDPE 1/2 BEND; INV. ELEV. = 1120.78'
12. TIE INTO 24" HEADER SYSTEM; INV. ELEV. = 1118.43'
13. TIE INTO UP-FLO FILTER VAULT INV. (IN) ELEV. = 1118.38'
14. TIE INTO UP-FLO FILTER VAULT INV. (OUT) ELEV. = 1117.38'
15. NYLOPLAST 12" INLET OR APPROVED EQUAL.
 TOP ELEV. = 1127.50'; INV. = 1125.70'
16. TIE ROOF DRAINS INTO DOWNSPOUTS 2.0' BELOW FINISHED FINISHED PAVEMENT. ROOF DRAINS SHALL BE 8" HDPE SLOPED AT 1% MINIMUM.
17. TIE ROOF DRAINS INTO DOWNSPOUTS 2.0' BELOW FINISHED FINISHED PAVEMENT. ROOF DRAINS SHALL BE 12" HDPE SLOPED AT 1% MINIMUM.

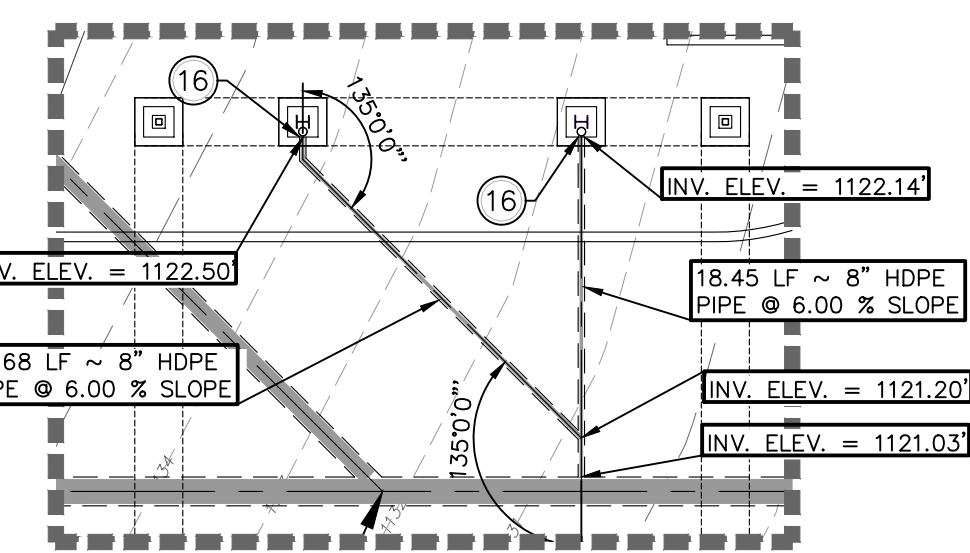

DETAIL "A"
SCALE: 1"=10'

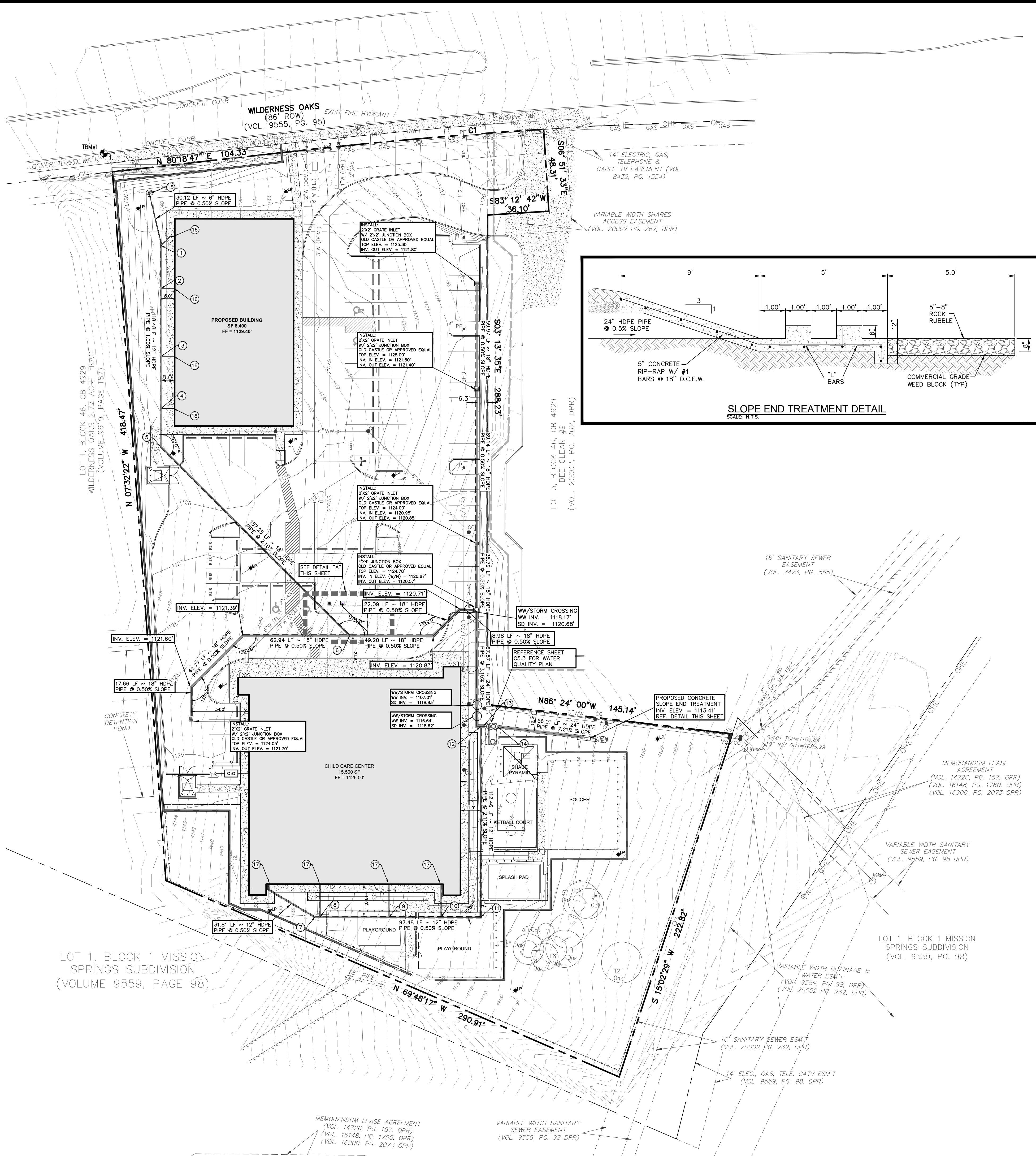

LEGEND		
EXISTING	PROPOSED	DESCRIPTION
(XXX)		PROPERTY (P.O.W.) LINE/ SUBDIVISION BOUNDARY/ ADJACENT PROPERTY RECORD INFORMATION
LP		BENCHMARK
LP		LIGHT POLE
PP		POWER POLE
EC		DOWN CITY
T		TRANSFORMER (SIZE VARIES)
		FIRE HYDRANT
		WATER VALVE
		WATER METER
		WATER METER VAULT
		WATER MANHOLE
		TELEPHONE RISER
		CABLE TV RISER
		ELECTRIC BOX
		ELECTRIC METER
		GAS VALVE
		GAS METER
		TRAFFIC CONTROL BOX
		TRAFFIC SIGNAL POST
		UNDERGROUND GAS LINE MARKER
		GREASE TRAP (SIZE VARIES)
		STORMDRAIN LINE
		WATER LINE
		FIRE LINE
		WASTEWATER LINE
		GAS LINE
		OVERHEAD ELECTRIC (PRIMARY)
		UNDERGROUND ELECTRIC (PRIMARY)
		UNDERGROUND ELECTRIC (SECONDARY)
		UNDERGROUND TELEPHONE
		UNDERGROUND CABLE
		ELECTRIC MANHOLE (SIZE VARIES)
		WASTEWATER MANHOLE (SIZE VARIES)
		STORMDRAIN MANHOLE (SIZE VARIES)
		TELEPHONE MANHOLE (SIZE VARIES)
		FIRE DEPARTMENT CONNECTION
		WASTEWATER CLEANOUT
		HEADER CURB
		SAWTOOTH CURB
		RETAINING WALL
		CHAINLINK FENCE
		CONCRETE SIDEWALKS
		CONTOUR
		DIRECTION OF FLOW
		SPOT ELEVATION/TOP OF CURB
		SPOT ELEVATION
		SWALE
		CONCRETE PAVEMENT
		ASPHALT PAVEMENT

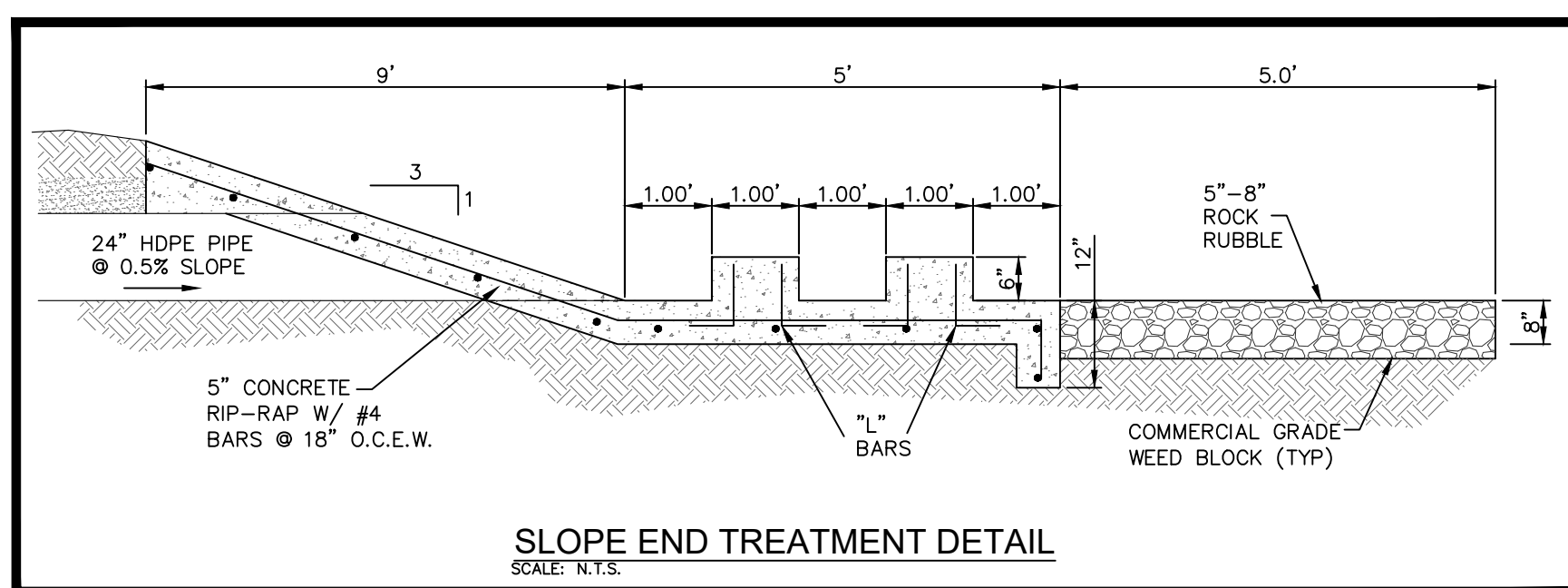

SLOPE END TREATMENT DETAIL
SCALE: N.T.S.

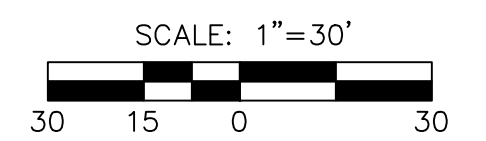

K LOVE ENGINEERING
 Site Development Engineering Services
 Firm No. 11042
 www.kloveengineering.com (210) 485-5683

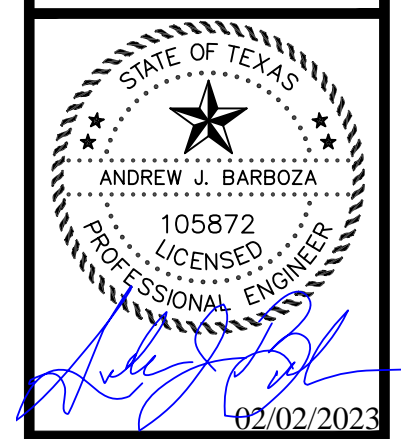

DATE	REVISIONS
02/26/2022	

OWNER:
 AZEA HOLDINGS, LLC
 11010 COACHLIGHT ST., STE 101
 SAN ANTONIO, TEXAS 78216

IVY KIDS OF STONE OAK
 24272 WILDERNESS OAK (SHOPPING CENTER)
 24278 WILDERNESS OAK (CHILD CARE CENTER)
 SAN ANTONIO, TEXAS 78258

DESIGNED BY: AJB
 DRAWN BY: RQ
 SCALE: 1"=30'
 DATE: 09/26/22
 SHEET NO:
EX-3A

THE LOCATION OF EXISTING UNDERGROUND UTILITIES ARE SHOWN IN AN APPROXIMATE WAY ONLY. THE CONTRACTOR SHALL DETERMINE THE EXACT LOCATION OF ALL EXISTING UTILITIES BEFORE COMMENCING WORK. HE AGREES TO BE FULLY RESPONSIBLE FOR ANY AND ALL DAMAGES WHICH MIGHT OCCUR BY HIS FAILURE TO EXACTLY LOCATE AND PRESERVE ANY AND ALL UNDERGROUND UTILITIES.



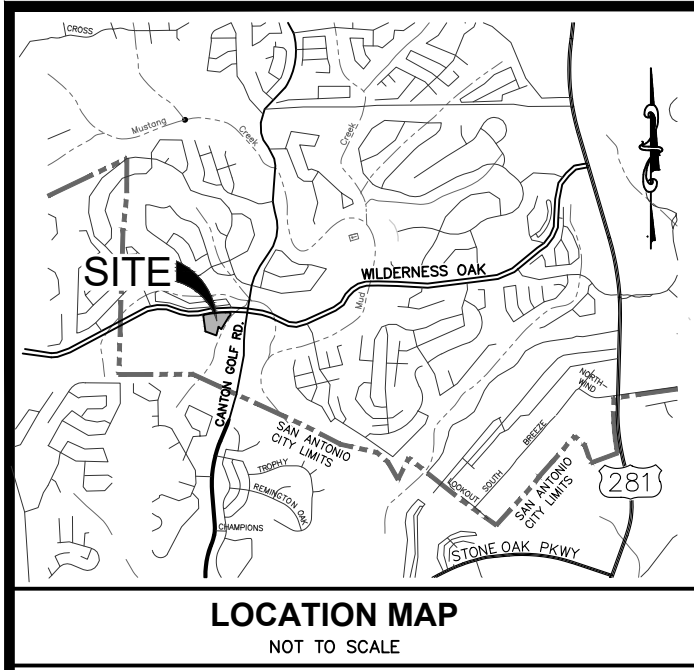

LOCATION MAP
NOT TO SCALE

TRENCH EXCAVATION SAFETY PROTECTION
 CONTRACTOR AND/OR CONTRACTOR'S INDEPENDENTLY RETAINED EMPLOYEE OR STRUCTURAL DESIGN/GEOTECHNICAL SAFETY/EQUIPMENT CONSULTANT, IF ANY, SHALL REVIEW THESE PLANS AND AVAILABLE GEOTECHNICAL INFORMATION AND THE ANTICIPATED INSTALLATION SITE(S) WITHIN THE PROJECT AREA IN ORDER TO IMPLEMENT CONTRACTOR'S TRENCH EXCAVATION SAFETY PROTECTION SYSTEMS PROGRAMS AND/OR PROCEDURES. THE CONTRACTOR'S IMPLEMENTATION OF THE SYSTEM'S PROGRAMS AND/OR PROCEDURES SHALL PROVIDE FOR ADEQUATE TRENCH EXCAVATION SAFETY PROTECTION THAT COMPLIES WITH AS A MINIMUM, OSHA STANDARDS GOVERNING TRENCH EXCAVATION. SPECIFICALLY, CONTRACTOR AND/OR CONTRACTOR'S INDEPENDENTLY RETAINED EMPLOYEE OR SAFETY CONSULTANT SHALL IMPLEMENT A TRENCH SAFETY PROGRAM IN ACCORDANCE WITH OSHA STANDARDS GOVERNING THE PRESENCE AND ACTIVITIES OF INDIVIDUALS WORKING IN AND AROUND TRENCH EXCAVATION.

BENCHMARKS

TBM#1: MAGNAIL ON EXISTING CONCRETE LOCATED APPROX. 12' NORTH OF NORTHEAST PROPERTY CORNER ALONG WILDERNESS OAKS
 ELEVATION = 1135.76'

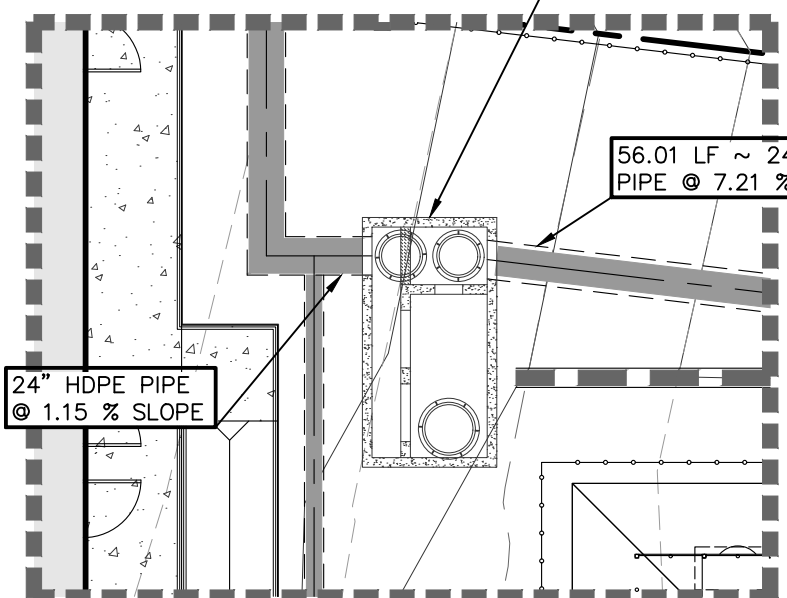
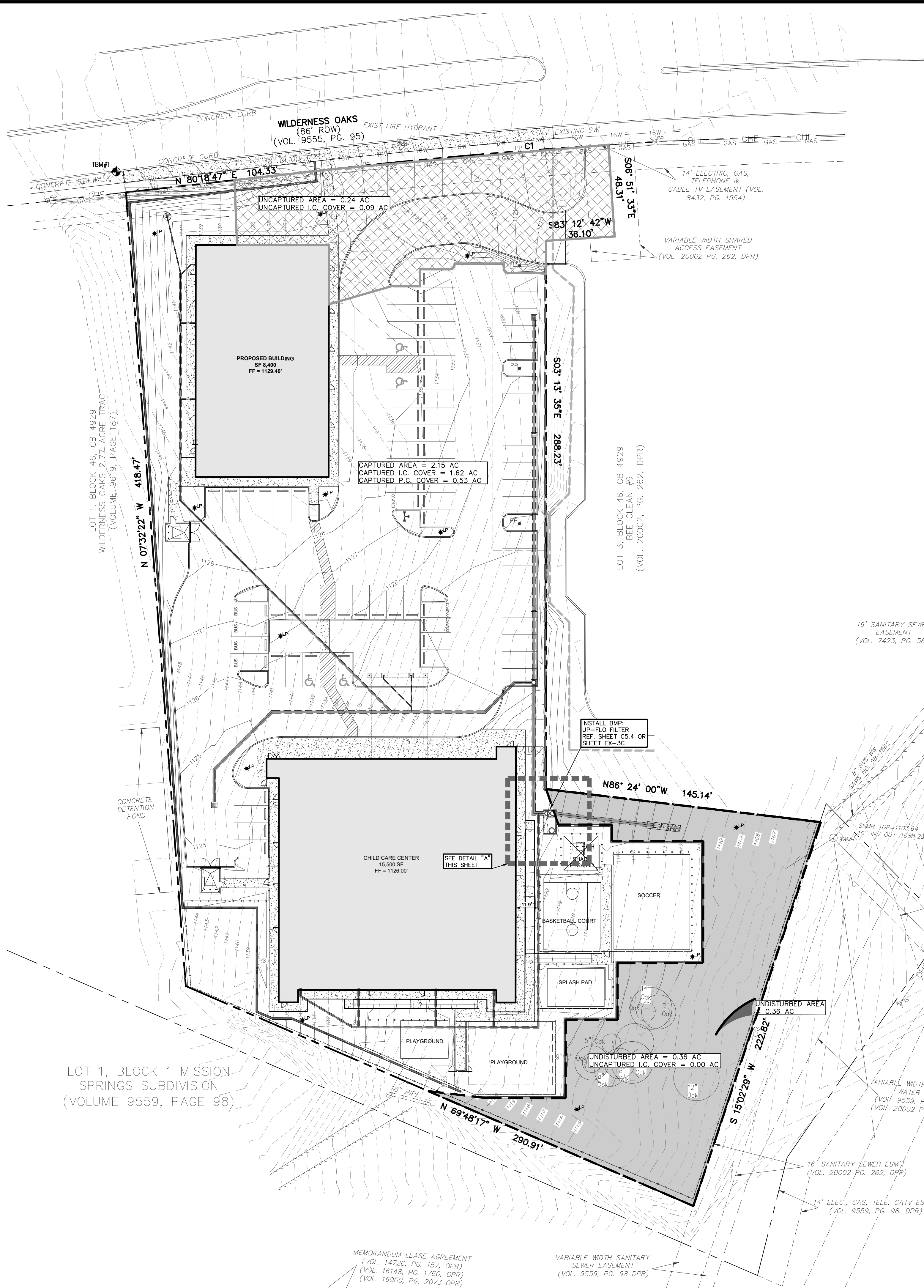

DETAIL "A"
SCALE: 1"=10'

THE LOCATION OF EXISTING UNDERGROUND UTILITIES ARE SHOWN IN AN APPROXIMATE WAY ONLY. THE CONTRACTOR SHALL DETERMINE THE EXACT LOCATION OF ALL EXISTING UTILITIES BEFORE COMMENCING WORK. HE AGREES TO BE FULLY RESPONSIBLE FOR ANY AND ALL DAMAGES WHICH MIGHT OCCUR BY HIS FAILURE TO EXACTLY LOCATE AND PRESERVE ANY AND ALL UNDERGROUND UTILITIES.

Calculations for Texas Commission on Environmental Quality TSS Removal Calculations
 Hydro International Up-Flow Filter - Sizing Spreadsheet Revision 1.0

Project Name: Ivy Kids Daycare
 Date Prepared: 02/20/2023

1. The Required Load Reduction for the Total Project:

Calculations from RD-348, Pages 3-27 to 3-30
 Page 3-29 Equation 3.3
 $L_u = 27.75A + 479$

Where:
 L_u = Required TSS removal loading from the proposed development + 80% of increased total
 A_u = Net increase in impervious area for the project
 P = Average annual precipitation, inches

Site Data: Determine Required Load Reduction Based on the Entire Project

Category	Area (Acres)	Imperviousness (%)	Load (lb/yr)
Predevelopment impervious area within the limits of the plan	0.00	0.00	0.00
Total predevelopment impervious area within the limits of the plan	0.00	0.00	0.00
Post-development impervious area within the limits of the plan	1.62	80.00	1,322.00
Total post-development impervious area within the limits of the plan	1.62	80.00	1,322.00
Net increase in impervious area	1.62	80.00	1,322.00
Required TSS removal loading	1.62	80.00	1,322.00
Required TSS removal loading per acre	1.62	80.00	815.43

2. Drainage Basin Parameters (This information should be provided for each basin):

Drainage Basin/Outlet Area No.	Area (Acres)	Imperviousness (%)	Load (lb/yr)
1	2.30	80.00	1,868.00
Predevelopment impervious area within drainage basin	0.00	0.00	0.00
Post-development impervious area within drainage basin	2.30	80.00	1,868.00
Total post-development impervious area within drainage basin	2.30	80.00	1,868.00
Net increase in impervious area	2.30	80.00	1,868.00
Required TSS removal loading	2.30	80.00	1,868.00
Required TSS removal loading per acre	2.30	80.00	812.17

3. Indicate the Proposed BMP Code for this Basin:

Proposed BMP = Up-Flow Filter CPZ
 Removal efficiency = 75 percent

4. Calculate Maximum TSS Load Removed (L_r) for this Drainage Basin by the Selected BMP Type:

RD-348 Page 3-33 Equation 3.7
 $L_r = (BMP\ Efficiency) \times P \times A_u \times I_u \times 4.34$

Where:
 A_u = Total On-Site drainage area in the BMP catchment area
 I_u = Imperviousness area in the BMP catchment area
 L_r = TSS load removed from the catchment area by the proposed BMP

Category	Area (Acres)	Imperviousness (%)	Load (lb/yr)
Predevelopment impervious area within the limits of the plan	0.00	0.00	0.00
Total predevelopment impervious area within the limits of the plan	0.00	0.00	0.00
Post-development impervious area within the limits of the plan	1.62	80.00	1,322.00
Total post-development impervious area within the limits of the plan	1.62	80.00	1,322.00
Net increase in impervious area	1.62	80.00	1,322.00
Required TSS removal loading	1.62	80.00	1,322.00
Required TSS removal loading per acre	1.62	80.00	815.43

5. Calculate Fraction of Annual Runoff to Treat in the Drainage Basin (Outlet Area):

Desired L_r vs L_u = 1,322 / 1,868 = 0.708

6. Calculate Capture Volume Required by the BMP Type for this Drainage Basin (Outlet Area):

Calculations from RD-348 Pages 3-34 to 3-35
 Rainfall Depth = 4.90 inches
 Post-Development Runoff Coefficient = 0.46
 On-site Water Quality Volume = 16,869 cubic feet

Calculations from RD-348 Pages 3-36 to 3-37
 Off-site area draining to BMP = 0.00 acres
 Off-site imperviousness area draining to BMP = 0.00 acres
 Imperviousness fraction of off-site area = 0.00
 Off-site Water Quality Volume = 0 cubic feet
 Total Capture Volume (required water quality volume x 1.20) = 20,243 cubic feet

7. Up-Flow Filter TSS Load Based Sizing:

Minimum Filter Module based on L_r = 10 modules
 Maximum Filter Release Rate = 0.56 cfs

7a. Additional Filter Modules to Increase Filter TSS Load Capacity:

Enter number of additional Modules = 4
 Total Number of Modules = 14
 Maximum Filter Release Rate = 0.78 cfs
 Annual TSS Load Capacity for Filter = 1,849 lb

Recalculated Capture Volume Required:
 Rainfall Intensity = 0.754 inches
 On-site Water Quality Volume = 3,648 cubic feet
 Off-site Water Quality Volume = 0 cubic feet
 Storage for Sediment = 770 cubic feet
 Total Capture Volume (required water quality volume x 1.20) = 4,418 cubic feet

Check for WQ Requirements Based on Filter Inflow and Outflow Equalization
 & Up-Flow Filter Sizing Based on Design Storm (see notes)

Parameter	Value	Units
Rainfall Intensity	0.46	in/hr
On-site Inflow Rate	0.25	cfs
Off-site Inflow Rate	0.00	cfs
Total Inflow Rate	0.25	cfs

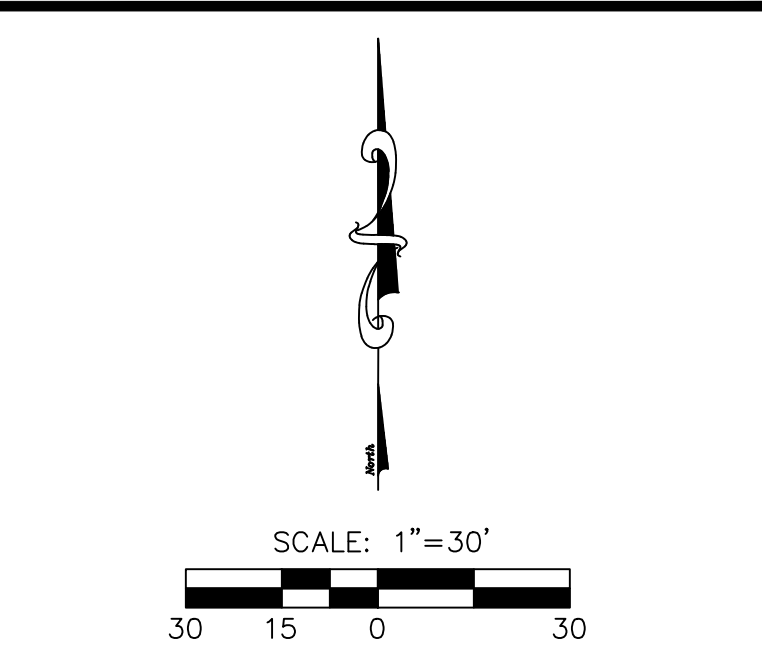

EXISTING	PROPOSED	DESCRIPTION
---	---	PROPERTY (P.O.W.) LINE/ SUBDIVISION BOUNDARY
---	---	ADJACENT PROPERTY RECORD INFORMATION
---	---	BENCHMARK
---	---	LIGHT POLE
---	---	POWER POLE
---	---	DOWN CURB
---	---	TRANSFORMER (SIZE VARIES)
---	---	FIRE HYDRANT
---	---	WATER VALVE
---	---	WATER METER
---	---	WATER METER VAULT
---	---	WATER MANHOLE
---	---	TELEPHONE RISER
---	---	CABLE TV RISER
---	---	ELECTRIC BOX
---	---	ELECTRIC METER
---	---	GAS VALVE
---	---	GAS METER
---	---	TRAFFIC CONTROL BOX
---	---	TRAFFIC SIGNAL POST
---	---	UNDERGROUND GAS LINE MARKER
---	---	GREASE TRAP (SIZE VARIES)
---	---	STORMDRAIN LINE
---	---	WATER LINE
---	---	FIRE LINE
---	---	WASTEWATER LINE
---	---	GAS LINE
---	---	OVERHEAD ELECTRIC (PRIMARY)
---	---	UNDERGROUND ELECTRIC (PRIMARY)
---	---	UNDERGROUND ELECTRIC (SECONDARY)
---	---	UNDERGROUND TELEPHONE
---	---	UNDERGROUND CABLE
---	---	ELECTRIC MANHOLE (SIZE VARIES)
---	---	WASTEWATER MANHOLE (SIZE VARIES)
---	---	STORMDRAIN MANHOLE (SIZE VARIES)
---	---	TELEPHONE MANHOLE (SIZE VARIES)
---	---	FIRE DEPARTMENT CONNECTION
---	---	WASTEWATER CLEANOUT CURB
---	---	HEADER CURB
---	---	SAWTOOTH CURB
---	---	RETAINING WALL
---	---	CHAINLINK FENCE
---	---	CONCRETE SIDEWALKS
---	---	COURT
---	---	DIRECTION OF FLOW
---	---	SPOT ELEVATION / TOP OF CURB
---	---	SPOT ELEVATION
---	---	SWALE
---	---	CONCRETE PAVEMENT
---	---	ASPHALT PAVEMENT

Texas Commission on Environmental Quality
 Water Pollution Abatement Plan
 General Construction Notes

- A written notice of construction must be submitted to the TCEQ regional office at least 48 hours prior to the start of any regulated activities. This notice must include:
 - The name of the approved project.
 - The activity start date; and
 - The contractor information of the primer contractor.
- All contractors conducting regulated activities associated with this project must be provided with complete copies of the approved Water Pollution Abatement Plan (WPAP) and the TCEQ letter indicating the specific conditions of its approval. During the course of these regulated activities, the contractors are required to keep on-site copies of the approved plan and approval letter.
- If any sensitive feature(s) (caves, solution cavity, sink hole, etc.) is discovered during construction, all regulated activities near the sensitive feature must be suspended immediately. The appropriate TCEQ regional office must be immediately notified of any sensitive features encountered during construction. Construction activities may not be resumed until the TCEQ has reviewed and approved the appropriate protective measures in order to protect any sensitive feature and the Edwards Aquifer from potentially adverse impacts to water quality.
- No temporary or permanent hazardous substance storage tank shall be installed within 150 feet of water supply source, distribution system, well, or sensitive feature.
- Prior to beginning any construction activity, all temporary erosion and sedimentation (E&S) control measures must be properly installed and maintained in accordance with the approved plans and manufacturer's specifications. If inspections indicate a control has been used inappropriately, or incorrectly, the applicant must replace or modify the control for site situations. These controls must remain in place until the disturbed areas have been permanently stabilized.
- Any sediment that escapes the construction site must be collected and properly disposed of before the next rain event to ensure it is not washed into surface streams, sensitive features, etc.
- Sediment must be removed from the sediment traps or sedimentation basins no later than when it occupies 50% of the basin's design capacity.
- Litter, construction debris, and construction chemicals exposed to stormwater shall be prevented from being discharged offsite.
- All spoils (excavated material) generated from the project site must be stored on-site with proper E&S controls. For storage or disposal of spoils at another site on the Edwards Aquifer Recharge Zone, the owner of the site must receive approval of a water pollution abatement plan for the placement of fill material or mass grading prior to the placement of spoils at the other site.
- If portions of the site will have temporary or permanent cease in construction activity lasting longer than 14 days, soil stabilization in those areas shall be initiated as soon as possible prior to the 14th day of inactivity, if activity will resume prior to the 21st day, stabilization measures are not required. If drought conditions or inclement weather prevent action by the 14th day, stabilization measures shall be initiated as soon as possible.
- The following records shall be maintained and made available to the TCEQ upon request:
 - the dates when major grading activities occur;
 - the dates when construction activities temporarily or permanently cease on a portion of the site; and
 - the dates when stabilization measures are initiated.
- The holder of any approved Edwards Aquifer protection plan must notify the appropriate regional office in writing and obtain approval from the executive director prior to initiating any of the following:
 - any physical or operational modification of any water pollution abatement structure(s), including but not limited to ponds, dams, berms, sewage treatment plants, and diversionary structures;
 - any change in the nature or character of the regulated activity from that which was originally approved or a change which would significantly impact the ability of the plan to prevent pollution of the Edwards Aquifer;
 - any development of land previously identified as undeveloped in the original water pollution abatement plan.

Austin Regional Office
 12100 Park 35 Circle, Building A
 Austin, Texas 78753-1808
 Phone (512) 338-2929
 Fax (512) 338-3765

San Antonio Regional Office
 14250 Judson Road
 San Antonio, Texas 78233-4480
 Phone (210) 490-3096
 Fax (210) 545-4329

THESE GENERAL CONSTRUCTION NOTES MUST BE INCLUDED ON THE CONSTRUCTION PLANS PROVIDED TO THE CONTRACTOR AND ALL SUBCONTRACTORS.

K LOVE ENGINEERING
 Site Development Engineering Services
 Firm No. 11042
 www.kloveengineering.com (210) 485-5463

STATE OF TEXAS
 ANDREW J. BARBOZA
 105872
 LICENSED PROFESSIONAL ENGINEER
 02/02/2023

OWNER:
IVY KIDS OF STONE OAK
 24272 WILDERNESS OAK (SHOPPING CENTER)
 24278 WILDERNESS OAK (CHILD CARE CENTER)
 SAN ANTONIO, TEXAS 78258
 WATER QUALITY PLAN

DESIGNED BY: AJB
 DRAWN BY: RQ
 SCALE: 1"=30'
 DATE: 09/26/22
 SHEET NO:
EX-3B

Date: Feb 02, 2023, 11:08am
 File: C:\PROJECTS\1303-00_Ivy Kids Daycare\Drawings\CAD\Water Quality Plans.dwg



Date: Feb 02, 2024, 1:08pm
 File: C:\Projects\Drawings\C5.4 - Water - Quality Detailing.dwg

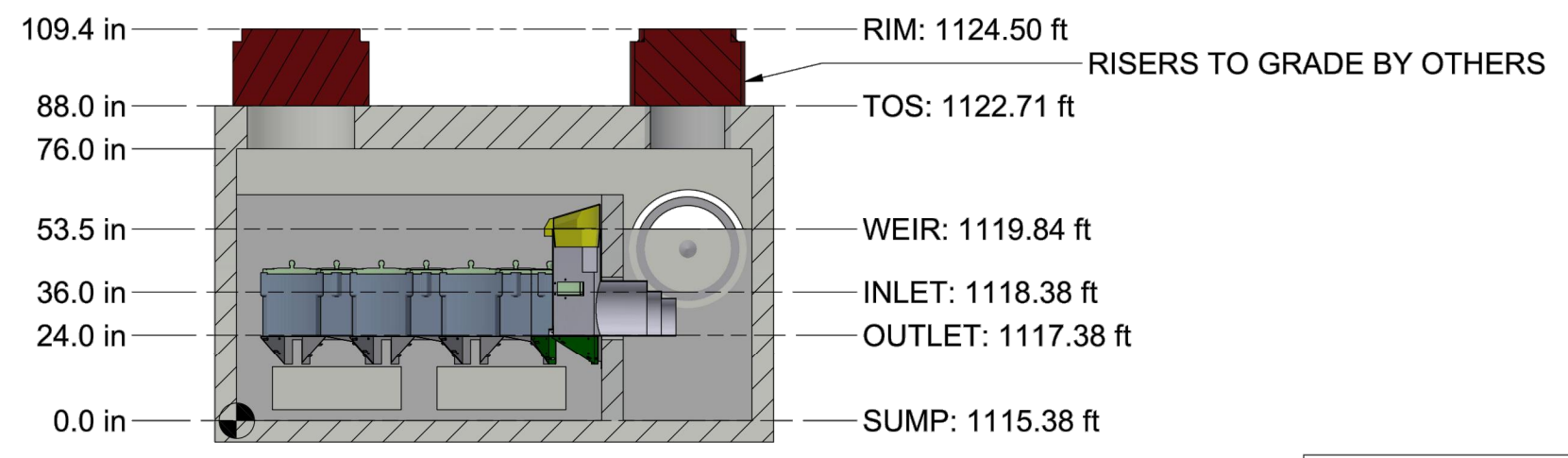
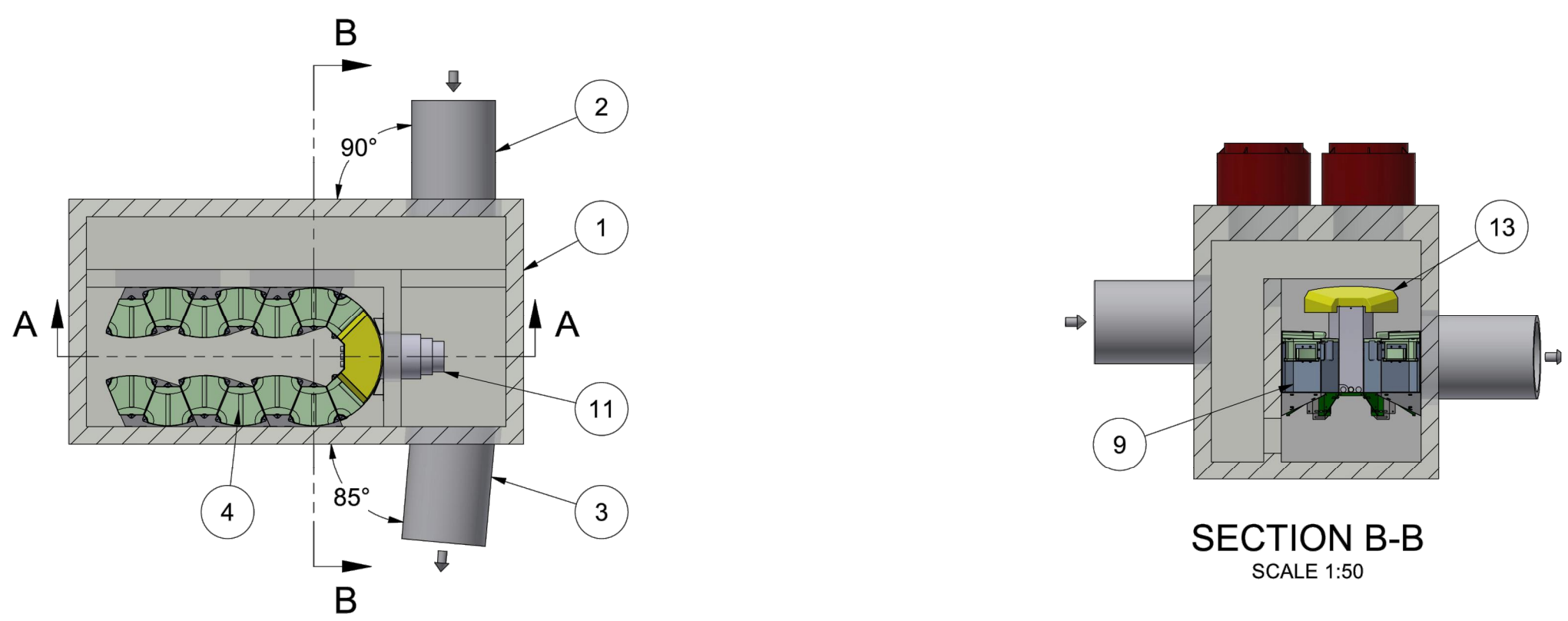

CAPACITIES:
 1. Minimum performance: 80% removal. NJDEP - NJDEP Blend; NJCAT, Sil-Co-Sil 106 (d50 = 22 microns) at the peak treatment flow.
 2. Maximum number of modules per outlet module: 38 **
 3. NJDEP peak treatment flow: .056 cfs (25 gpm) per module, CPZ

ADDITIONAL DESIGN INFORMATION:
 1. * Normal operating W.S.E. is 2.46' above the outlet invert at the peak treatment flow of .056 cfs (25 gpm) per module. For a given flow the head requirement can be reduced by adding additional filters.
 2. ** Treatment flows that require more modules will require a larger vault design or different arrangement.
 3. Media Types Available: New Jersey - Ribbons; Elsewhere - CPZ
 4. Unit shall conform to HS20-44 load ratings.

ITEM	QTY	DESCRIPTION	TYPE	SIZE (in)
1	1	PRECAST VAULT		6ft X 12ft
2	1	UFF INLET PIPE	HDPE	24
3	1	UFF OUTLET PIPE	HDPE	24
4	14	MODULE LID		
5	3	SUPPORT FRAME		
6	1	COVER 30 IN		30
7	2	WEDGE WALL MOUNT		
8	2	COVER 24 IN		24
9	14	MODULE BODY		
10	3	SUPPORT FRAME LH		
11	1	OUTLET MODULE		
12	3	SUPPORT FRAME RH		
13	1	BYPASS HOOD		

1. STRUCTURE WALL AND SLAB THICKNESSES ARE NOT TO SCALE.
 2. CONTACT HYDRO INTERNATIONAL FOR A BOTTOM OF STRUCTURE ELEVATION PRIOR TO SETTING THE STRUCTURE.
 3. CONTRACTOR TO CONFIRM RIM, PIPE INVERTS, PIPE DIA. AND PIPE ORIENTATION PRIOR TO RELEASE OF UNIT TO FABRICATION.
 4. CONTRACTOR IS RESPONSIBLE FOR MATERIALS AND LABOR TO BRING CASTINGS TO FINISHED GRADE.
 5. ACTUAL DEPTH OF STRUCTURE MAY VARY DEPENDING ON AVAILABLE PRECAST FORMS. CONTRACTOR TO MEASURE HEIGHT OF STRUCTURE TO ENSURE THAT DEPTH OF EXCAVATION IS CORRECT.

REVISION HISTORY

REV	BY	DESCRIPTION	DATE
-	WCS	FIRST RELEASE	12/13/2022

PROJECTION

IF IN DOUBT ASK

DATE: 12/13/2022 SCALE: 1:50
 DRAWN BY: WCS CHECKED BY: EKM APPROVED BY:

TITLE: UP-FLO FILTER 6ft X 12ft
 14 MODULES
 UFF-1
 IVY KIDS OF STONE OAK SF #314616
 SAN ANTONIO, TX
 Patent: www.hydro-int.com/patents

Hydro International
 hydro-int.com
 ©2021 HYDRO INTERNATIONAL

WEIGHT: MATERIAL:
 STOCK NUMBER: 1
 DRAWING NO.: 22_12_3630-UFF-1
 SHEET SIZE: B SHEET: 1 OF 2

C5.4.1

UP-FLO FILTER DETAILS 1
 NOT TO SCALE

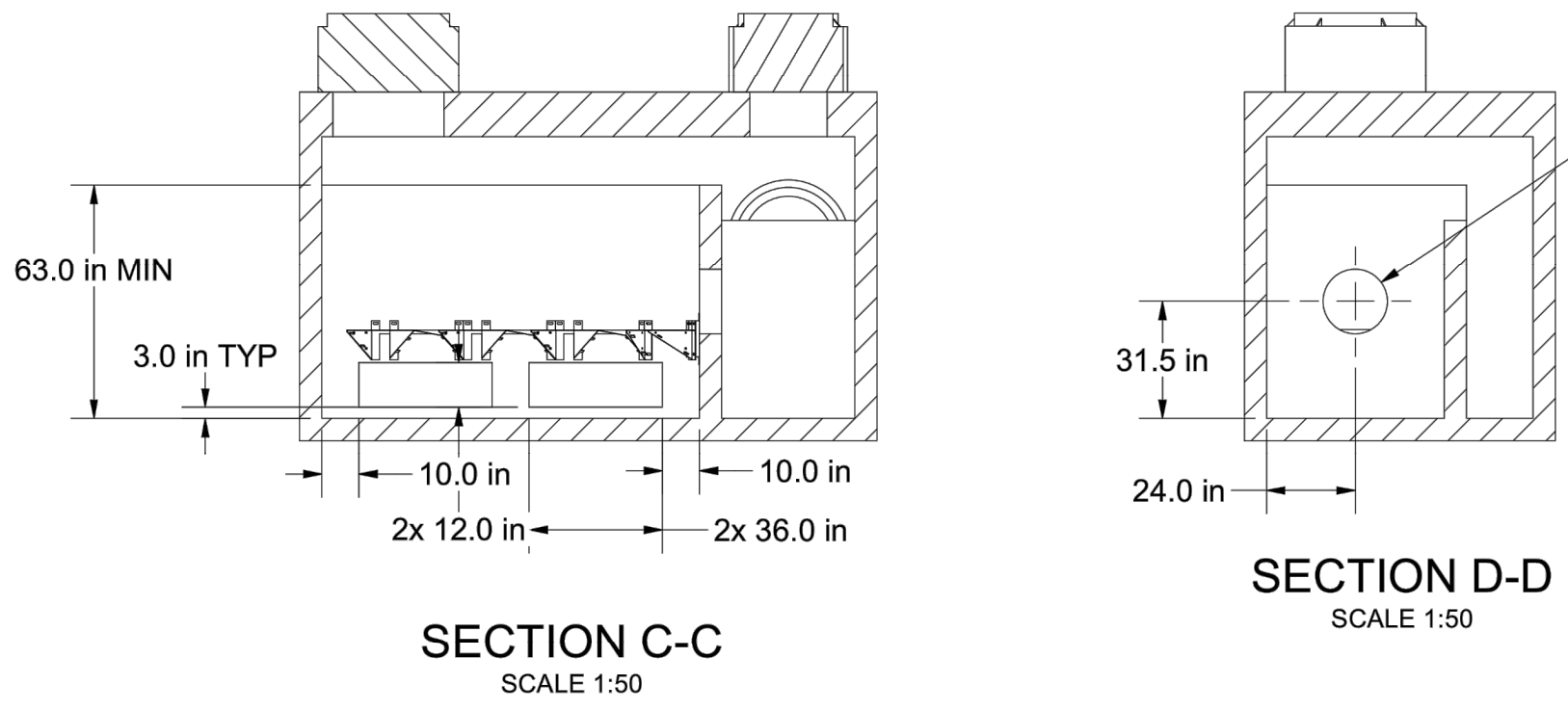
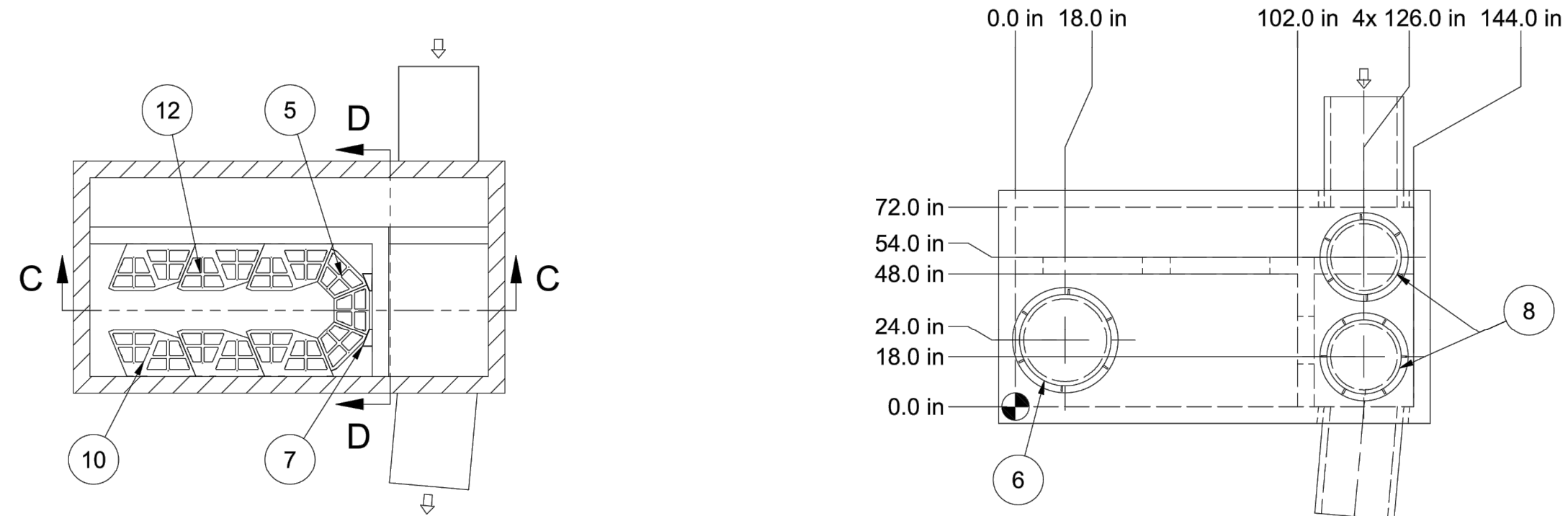

ITEM	QTY	DESCRIPTION	SIZE (in)
1	1	PRECAST VAULT	6ft X 12ft
2	1	UFF INLET PIPE	24
3	1	UFF OUTLET PIPE	24
4	14	MODULE LID	
5	3	SUPPORT FRAME	
6	1	COVER 30 IN	30
7	2	WEDGE WALL MOUNT	
8	2	COVER 24 IN	24
9	14	MODULE BODY	
10	3	SUPPORT FRAME LH	
11	1	OUTLET MODULE	
12	3	SUPPORT FRAME RH	
13	1	BYPASS HOOD	

1. STRUCTURE WALL AND SLAB THICKNESSES ARE NOT TO SCALE.
 2. CONTACT HYDRO INTERNATIONAL FOR A BOTTOM OF STRUCTURE ELEVATION PRIOR TO SETTING THE STRUCTURE.
 3. CONTRACTOR TO CONFIRM RIM, PIPE INVERTS, PIPE DIA. AND PIPE ORIENTATION PRIOR TO RELEASE OF UNIT TO FABRICATION.
 4. CONTRACTOR IS RESPONSIBLE FOR MATERIALS AND LABOR TO BRING CASTINGS TO FINISHED GRADE.
 5. ACTUAL DEPTH OF STRUCTURE MAY VARY DEPENDING ON AVAILABLE PRECAST FORMS. CONTRACTOR TO MEASURE HEIGHT OF STRUCTURE TO ENSURE THAT DEPTH OF EXCAVATION IS CORRECT.

PROJECTION

IF IN DOUBT ASK

DATE: 12/13/2022 SCALE: 1:50
 DRAWN BY: WCS CHECKED BY: EKM APPROVED BY:

TITLE: UP-FLO FILTER 6ft X 12ft
 14 MODULES
 UFF-1
 IVY KIDS OF STONE OAK SF #314616
 SAN ANTONIO, TX

Hydro International
 hydro-int.com
 ©2021 HYDRO INTERNATIONAL

WEIGHT: MATERIAL:
 STOCK NUMBER: 1
 DRAWING NO.: 22_12_3630-UFF-1
 SHEET SIZE: B SHEET: 2 OF 2

C5.4.2

UP-FLO FILTER DETAILS 2
 NOT TO SCALE

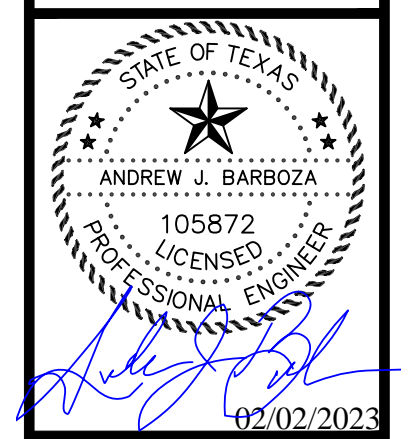

DATE	REVISIONS
02/02/2023	

OWNER:
 AZEA HOLDINGS, LLC
 11010 COACHLIGHT ST., STE 101
 SAN ANTONIO, TEXAS 78216

IVY KIDS OF STONE OAK
 24272 WILDERNESS OAK (SHOPPING CENTER)
 24278 WILDERNESS OAK (CHILD CARE CENTER)
 SAN ANTONIO, TEXAS 78258

WATER QUALITY DETAILS

DESIGNED BY: AJB
 DRAWN BY: RQ
 SCALE: 1" = 30"
 DATE: 09/26/22
 SHEET NO.

EX-3C

**Calculations for Texas Commission on Environmental Quality TSS Removal Calculations
Hydro International Up-Flo® Filter - Sizing Spreadsheet Revision 1.0**

Project Name: **Ivy Kids Daycare**
Date Prepared: **12/8/2022**

1. The Required Load Reduction for the Total Project.

Calculations from RG-348, Pages 3-27 to 3-30
Page 3-29 Equation 3.3:

$$L_M = 27.2(A_N \times P)$$

Where:

$L_{M \text{ TOTAL PROJECT}}$ = Required TSS removal resulting from the proposed development = 80% of increased load
 A_N = Net increase in impervious area for the project
P = Average annual precipitation, inches

Site Data: Determine Required Load Removal Based on the Entire Project

County =	Bexar	
Total project area included in plan =	2.75	acres
Predevelopment impervious area within the limits of the plan =	0.00	acres
Total post-development impervious area within the limits of the plan =	1.71	acres
Total post-development impervious cover fraction =	0.62	
P =	30	inches
$L_{M \text{ TOTAL PROJECT}}$ =	1395	lb
Number of drainage basins / outfalls areas leaving the plan area =	1	

2. Drainage Basin Parameters (This information should be provided for each basin).

Drainage Basin/Outfall Area No. =	1	
Total drainage basin/outfall area =	2.39	acres
Predevelopment impervious area within drainage basin/outfall area =	0.00	acres
Post-development impervious area within drainage basin/outfall area =	1.62	acres
Post-development impervious fraction within drainage basin/outfall area =	0.68	
$L_{M \text{ THIS BASIN}}$ =	1,322	lb

3. Indicate the Proposed BMP Code for this Basin.

Proposed BMP = **Up-Flo® Filter CPZ**
Removal efficiency = **78** percent

4. Calculate Maximum TSS Load Removed (L_R) for this Drainage Basin by the Selected BMP Type.

RG-348 Page 3-33 Equation 3.7:

$$L_R = (\text{BMP efficiency}) \times P \times (A_I \times 34.6 + A_P \times 0.54)$$

Where:

A_C = Total On-Site drainage area in the BMP catchment area
 A_I = Impervious area proposed in the BMP catchment area
 A_P = Pervious area remaining in the BMP catchment area
 L_R = TSS Load removed from this catchment area by the proposed BMP

A_C =	2.39	acres
A_I =	1.62	acres
A_P =	0.77	acres
L_R =	1,321	lb

5. Calculate Fraction of Annual Runoff to Treat the Drainage Basin / Outfall Area.

Note

Desired L_M THIS BASIN = lb
 $F = 1.056$

6. Calculate Capture Volume Required by the BMP Type for this Drainage Basin / Outfall Area.

Calculations from RG-348 Pages 3-34 to 3-36

Rainfall Depth = 4.00 inches
 Post Development Runoff Coefficient = 0.48
 On-site Water Quality Volume = 16,805 cubic feet

Calculations from RG-348 Pages 3-36 to 3-37

Off-site area draining to BMP = acres
 Off-site Impervious cover draining to BMP = acres
 Impervious fraction of off-site area = 0
 Off-site Runoff Coefficient = 0.00
 Off-site Water Quality Volume = 0 cubic feet
 Storage for Sediment = 3,361 cubic feet
Total Capture Volume (required water quality volume x 1.20) = 20,166 cubic feet

7. Up-Flo® Filter TSS Load Based Sizing.

Minimum Filter Modules based on L_R = 10 modules
 Maximum Filter Release Rate = 0.56 cfs

7a. Additional Filter Modules to Increase Filter TSS Load Capacity:

Enter number of additional Modules = modules
 Total Number of Modules = 14 modules
 Maximum Filter Release Rate = 0.78 cfs
 Annual TSS Load Capacity for Filter = 1,849 lb

Recalculated Capture Volume Required:

$F = 0.754$
 Rainfall Depth = 0.92 inches
 On-site Water Quality Volume = 3,848 cubic feet
 Off-site Water Quality Volume = 0 cubic feet
 Storage for Sediment = 770 cubic feet
Total Capture Volume (required water quality volume x 1.20) = 4,618 cubic feet

Check for WQv Requirement Based on Filter Inflow and Outflow Equalization

8. Up-Flo® Filter Sizing Based on Design Storm (No storage).

Rainfall Intensity $i = 0.46$ in/hr
 On Site Inflow Rate = 0.53 cfs
 Offsite Inflow Rate = 0.00 cfs
 Total Inflow Rate = 0.53 cfs



Texas Commission of Environmental Quality - Edwards Aquifer Sizing to RG-348

The Up-Flo[®] Filter with CPZ media is approved by the Texas Commission on Environmental Quality (TCEQ) for use within the Edwards Aquifer recharge zone.

Complying with the Edwards Aquifer Rules: Technical Guidance on Best Management Practices, known as RG-348, provides detailed descriptions and examples of the process used to calculate the mass of Total Suspended Solids (TSS) load resulting from any increase in impervious area that a development may create. This increase in load is then mitigated through the use of approved Best Management Practices (BMPs) that must remove 80% of the net increase in TSS load. To simplify the calculation TCEQ developed a spreadsheet that standardizes the calculation for each BMP. This Technical Abstract refers to RG-348 and to the TCEQ approved Up-Flo[®] Filter sizing spreadsheet available from Hydro International.

Section 3.3 of RG-348 states: "Under 30 TAC Chapter 213, 80% of the increase in TSS load resulting from development (over background) must be removed."

The following steps are used to calculate the load and size the BMP:

- (1) Calculate the required TSS (load) removal, which is based on the net increase in impervious acres
- (2) Select a BMP or combination of BMPs
- (3) Calculate the TSS load removal by each BMP
- (4) Calculate the percentage of runoff that must be treated to achieve the 80% removal (total load reduction)
- (5) Adjust the size or type of BMP(s) to ensure load removed is equal to or exceeds the load increase

It is important to understand that RG-348 uses a total load reduction model. The BMP must be sized to remove a mass of material based on the volume of water treated. It does not require a BMP to be 80% efficient to meet the treatment goal.

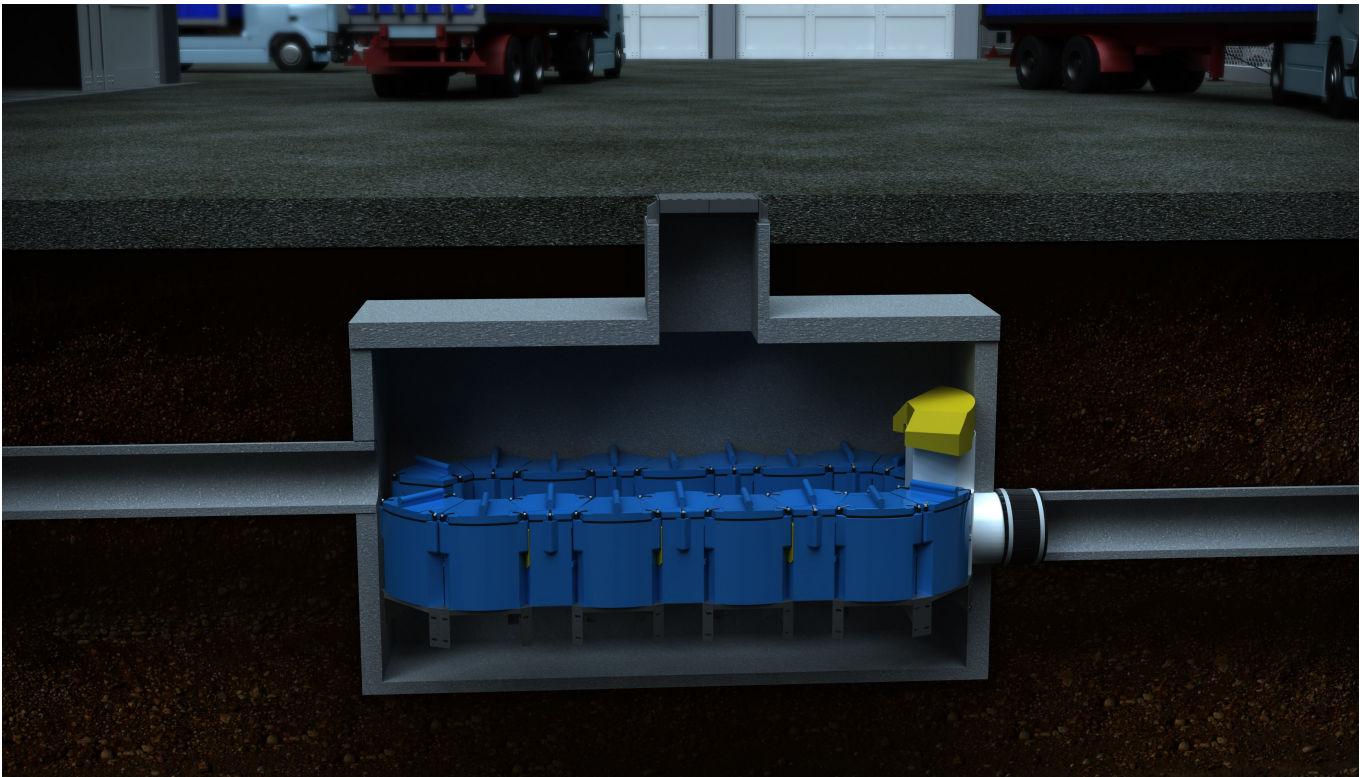

Calculation Equations:

- The required TSS load reduction is calculated using the Equation 3.2:

$$L_M = (0.8 \times 0.226) \times (A_N \times P \times 0.9 \times 170 \text{ mg/L} - A_N \times 0.03 \times 80 \text{ mg/L})$$

Where:

L_M	= Required load reduction (pounds)
A_N	= Net increase in impervious area (acres)
P	= Average annual precipitation (inches)
0.8	= 80% reduction factor
170	= TSS concentration from impervious area (mg/L)
80	= TSS concentration from pervious area (mg/L)
0.9	= Runoff coefficient for impervious area
0.03	= Runoff coefficient for pervious area
0.226	= Unit conversion factor

This equation simplifies to Equation 3.3:

$$L_M = 27.2(A_N \times P)$$

- The required load reduction is calculated using the Equation 3.7:

$$L_R = (\text{BMP efficiency}) \times 0.226 \times P \times (A_I \times 0.9 \times 170 \text{ mg/L} + A_P \times 0.03 \times 80 \text{ mg/L})$$

Where:

L_R	= Load removed by BMP (pounds)
BMP eff	= TSS Removal efficiency of selected BMP
P	= Average annual precipitation (inches)
A_I	= Impervious tributary area (acres)
A_P	= Pervious tributary area (acres)
170	= TSS concentration from impervious area (mg/L)
80	= TSS concentration from pervious area (mg/L)
0.9	= Runoff coefficient for impervious area
0.03	= Runoff coefficient for pervious area
0.226	= Unit conversion factor

This equation simplifies to Equation 3.8:

$$L_R = (\text{BMP efficiency}) \times P \times (A_I \times 34.6 + A_P \times 0.54)$$

- The fraction of rainfall treated is calculated using the Equation 3.9

$$F = L_M / L_R$$

Where:

F	= Fraction of annual rainfall treated
L_M	= Required load reduction (80% of the net increase in TSS Load)
L_R	= Load removal for each BMP summed

The value of F must be less than 1 otherwise insufficient water is being treated to achieve the required load reduction. In other words, the BMP must be capable of treating more runoff than would occur in the average year to achieve the load reduction. If the number is greater than 1 the BMP is not able to treat the required runoff and must be made larger or another BMP employed in a treatment train.

It is important to understand that this is a load (mass) reduction model and that the BMP(s) must remove a mass of material and can be assigned an individual BMP TSS efficiency of less than or more than 80%. The BMP size is controlled by the mass capture capacity of the BMP(s) so that the total mass removed is greater than the net increase in TSS from the development calculated in Equation 3.2 and that the fraction of rainfall treated as calculated in Equation 3.9 is less than 1.

Up-Flo® Filter Mass Load Capacity

The Up-Flo® Filter has been independently field tested and approved by TCEQ based on this field testing. The average TSS concentration reduction was 78% with a flow weighted flow weighted mass balance TSS reduction of 88%. The Up-Flo® Filter can remove 132 lb of TSS load per filter module.

Up-Flo® Filter Sizing Using TCEQ Approved Spreadsheet

The BMP efficiency controls the load reduction initially assigned to the BMP based on the total net increase in TSS load. The BMP does not need to have an assigned TSS efficiency reduction of 80% or greater to meet the required TSS load reduction. There is a difference between the TSS efficiency and the TSS Load Reduction capacity of the filter. TCEQ assigns the filter efficiency based on the average TSS concentration reduction for the qualifying monitored storms in the test.

Access Online: <https://designtools.hydro-int.com/home>

Example Calculation

Area: 5 ac
 Predevelopment Impervious: 1 ac
 Post-Development Impervious: 4 ac
 Net Increase in Impervious: 3 ac (going to new BMP)
 No offsite areas draining to the site.
 Williamson County

Steps 1 & 2: Site and Drainage Basin Details

Step 1 and 2 show identical TSS loads (L_M) as only a single drainage basin is being considered. If the site has multiple drainage basins Step 2 - 7 will need to be replicated for each drainage basin.

1. The Required Load Reduction for the Total Project.

Calculations from RG-348, Pages 3-27 to 3-30

Page 3-29 Equation 3.3:

$$L_M = 27.2(A_N \times P)$$

Where:

$L_{M \text{ TOTAL PROJECT}}$ = Required TSS removal resulting from the proposed development = 80% of increased load

A_N = Net increase in impervious area for the project

P = Average annual precipitation, inches

Site Data: Determine Required Load Removal Based on the Entire Project

County =	Williamson	
Total project area included in plan =	3.00	acres
Predevelopment impervious area within the limits of the plan =	0.00	acres
Total post-development impervious area within the limits of the plan =	2.00	acres
Total post-development impervious cover fraction =	0.67	
P =	32	inches
$L_{M \text{ TOTAL PROJECT}}$ =	1741	lb
Number of drainage basins / outfalls areas leaving the plan area =	1	

2. Drainage Basin Parameters (This information should be provided for each basin).

Drainage Basin/Outfall Area No. =	1	
Total drainage basin/outfall area =	3.00	acres
Predevelopment impervious area within drainage basin/outfall area =	0.00	acres
Post-development impervious area within drainage basin/outfall area =	2.00	acres
Post-development impervious fraction within drainage basin/outfall area =	0.67	
$L_{M \text{ THIS BASIN}}$ =	1,741	lb

Step 3: Up-Flo® Filter Efficiency

The Up-Flo® Filter has been assessed to have a TSS concentration reduction efficiency of 78%. This is found in Step 3 of the design spreadsheet and should not be altered, but in some sites may require additional filter modules to be installed to achieve the required total load reduction.

Adding additional filter modules also increases the total flow the filter can treat, which has the added benefit of reducing the required Water Quality Capture Volume in Step 6.

3. Indicate the Proposed BMP Code for this Basin.

Proposed BMP = **Up-Flo® Filter CPZ**
Removal efficiency = **78** percent

Step 4: Up-Flo® Filter Mass Removal

Step 4 calculates the Up-Flo® Filter's TSS mass removal (L_R) based on the 78% efficiency rating. In the example, L_M calculated in Step 2 = 1741 lb and L_R calculated in Step 4 is also = 1741 lb. This is because the 2% difference for 80% TSS load reduction is within the rounding error of the calculation for small drainage basins.

4. Calculate Maximum TSS Load Removed (L_R) for this Drainage Basin by the Selected BMP Type.

RG-348 Page 3-33 Equation 3.7:

$$L_R = (\text{BMP efficiency}) \times P \times (A_I \times 34.6 + A_P \times 0.54)$$

Where:

A_C = Total On-Site drainage area in the BMP catchment area

A_I = Impervious area proposed in the BMP catchment area

A_P = Pervious area remaining in the BMP catchment area

L_R = TSS Load removed from this catchment area by the proposed BMP

A_C =	3.00	acres
A_I =	2.00	acres
A_P =	1.00	acres
L_R =	1,741	lb

Step 5: Fraction of Annual Rainfall Treated

Step 5 calculates the fraction (F) of water treated on an annual basis using Equation 3.9, $F = L_R / L_M$, which must be less than 1.

Any small differences in L_M and L_R at this point show in F . Note the user must manually input the value of L_M in Step 5 as it is possible that the designer is splitting the treatment between two or more BMPs and is putting less load into this BMP.

5. Calculate Fraction of Annual Runoff to Treat the Drainage Basin / Outfall Area.

Note

Desired L_M THIS BASIN = **1,741** lb
 F = **1.00**

Changing the Site's TSS Removal Target for values other than 80% Load Reduction

The Up-Flo® Filter can be used for TSS removals for more or less than the standard 80% TSS for a site. This can be achieved in Step 5 by using the following procedure developed by TCEQ.

First calculate the ratio between 80% and the desired TSS reduction using the formula $X / 80$ where X is the desired TSS reduction.

Multiply L_M in Step 2 by this ratio to get a new value for L_M and enter that value in Step 5.

Example: For 85% TSS the ratio is $85 / 80 = 1.06$

Multiply L_M in Step 2 by this value, $1741 \times 1.06 = 1850$ lb of TSS load removal is required for 85% TSS Load Reduction.

This value is then entered in Step 5. At this stage F will exceed 1 and the BMP size will need to be altered to reduce F to below 1 again. **This is done in Step 7.**

Step 6: Capture Volume

The Rainfall Depth, Post Development Runoff Coefficient, and On-Site Water Quality Volume are all values calculated by the spreadsheet. Any off-site water draining to the BMP should also be added in Step 6. Some of the Total Capture Volume is held within the Up-Flo® Filter chamber. Refer to Hydro International for this volume once the number of filter modules has been calculated to get a vault size.

The Rainfall Depth is related to the Fraction of Treated Rainfall (F). Refer to RG-348, Table 3-5. The smaller the value of F, the larger the BMP is relative to the site size and the less water is required to be captured. This is because the BMP is treating a greater amount of the runoff.

6. Calculate Capture Volume Required by the BMP Type for this Drainage Basin / Outfall Area.

Calculations from RG-348 Pages 3-34 to 3-36

Rainfall Depth =	4.00	inches
Post Development Runoff Coefficient =	0.47	
On-site Water Quality Volume =	20,651	cubic feet

Calculations from RG-348 Pages 3-36 to 3-37

Off-site area draining to BMP =	0.00	acres
Off-site Impervious cover draining to BMP =	0.00	acres
Impervious fraction of off-site area =	0	
Off-site Runoff Coefficient =	0.00	
Off-site Water Quality Volume =	0	cubic feet
Storage for Sediment =	4,130	cubic feet
Total Capture Volume (required water quality volume x 1.20) =	24,781	cubic feet

Step 7: Up-Flo® Filter Sizing

In Step 7 the spreadsheet calculates the minimum number of Filter modules required to treat for the TSS load L_R in Step 5, however due to the Filter's 78% efficiency rating the treated Rainfall Fraction in Step 5 may exceed 1. In this case additional filter modules can be added in Step 7a.

The spreadsheet then recalculates a new value for F and the Total Capture Volume based on this new F value. In some cases it may be cost effective to increase the number of filter modules to reduced the Water Capture Volume, balancing filter cost against storage volume cost.

Maximum Release Rate

Each Up-Flo® Filter Module runs at maximum filter rate at about 30 inches of head. To achieve the values in Step 7 and 7a, an operating head of 30 inches is required. If a lower head is required contact Hydro International for assistance. The Maximum Release Rate is the filtration rate for the filter as sized in Step 7.

7. Up-Flo® Filter TSS Load Based Sizing.

Minimum Filter Modules based on L_R =	13	modules
Maximum Release Rate =	0.74	cfs

7a. Additional Filter Modules to Increase Filter TSS Load Capacity:

Enter number of additional Modules =	1	modules
Total Number of Modules =	14	modules
Maximum Release Rate =	0.79	cfs
Annual TSS Load Capacity for Filter =	1,873	lb

Recalculated Capture Volume Required:

F =	0.93	
Rainfall Depth =	2.20	inches
On-site Water Quality Volume =	11,358	cubic feet
Off-site Water Quality Volume =	0	cubic feet
Storage for Sediment =	2,272	cubic feet
Total Capture Volume (required water quality volume x 1.20) =	13,629	cubic feet

PERMANENT STORMWATER SECTION

ATTACHMENT G

Inspection, Maintenance, Repair and Retrofit Plan

An Inspection, Maintenance, Repair and Retrofit Plan have been attached on the following pages.

ATTACHMENT G

Inspection, Maintenance, Repair and Retrofit Plan

PROJECT NAME AZEA Holdings, LLC
ADDRESS 11010 Coachlight St, Ste 101
CITY, STATE ZIP San Antonio, TX 78216

Hydro International Up-Flo Filter

Particular attention should be paid to floating debris that can eventually clog the control valve.

- *Filter Underdrain.* Clean the underdrain piping network to remove any sediment buildup at least every two years, or as needed to maintain the design drawdown time.
- *Mowing.* Grass areas in and around cartridge filters must be mowed at least twice annually to limit vegetation height to 18 inches. More frequent mowing to maintain aesthetic appeal may be necessary in landscaped areas.
- *Bladder Control Valve.* The bladder control valve should be checked for proper operation in automatic and manual mode at least once per quarter. Should any operational problems be found repairs or replacement should be completed immediately.
- *Filtration Chamber Outfall.* The outfall point should be inspected at least once per quarter to insure that the discharge is leaving the filter by gravity.
- *Filter Canisters.* Clean the filter canisters at least once per quarter. Replace any damaged canisters immediately.
- *Controls.* Verify that all controls are functioning correctly at least once per month and after each rainfall event. Repair or replace any components that are inoperative.
- *Security Fencing.* Check and verify that the BMP facility site is secure at least once per month. Any site found to be insecure should be made secure immediately.

With each inspection, any damage to the structural elements of the system (pipes, retaining walls, etc.) must be identified and repaired immediately. “Proper” disposal of accumulated silt shall be accomplished following Texas Commission on Environmental Quality specifications. BMP maintenance frequently requires the disposal of accumulated sediment and other material. These materials are normally classified as special wastes when disposed of in municipal landfills. A Type 1 Municipal Solid Waste (MSW) landfill can accept household waste; disposal of wastes (i.e., sediment, etc) from the Jellyfish Filter will be in accordance with 30 TAC 330 and 335.

An amended copy of this document will be provided to the Texas Commission on Environmental Quality within thirty (30) days of any changes in the following information. After all inspections results shall be written and records maintained and made available on request by TCEQ officials. Upon transfer of ownership or maintenance responsibility:

The seller must inform the buyer of all requirements of the basin maintenance. TCEQ must be notified and receive the form “TCEQ -10623 change in responsibility for maintenance on permanent Best Management Practices and Measures”. In addition, TCEQ and SAWS Resource Protection Division shall receive a signed, dated copy of this maintenance plan from the new owner.

PERMANENT STORMWATER SECTION

ATTACHMENT H

Pilot-scale Field Testing

This site will not have a pilot-scale field testing. The existing BMP is in compliance with the TCEQ Guidance Manual.

PERMANENT STORMWATER SECTION

ATTACHMENT I

Measures for Minimizing Surface Stream Contamination

Any points where discharge from this site is concentrated and erosive velocities exist will include appropriately sized energy dissipaters to reduce velocities to non-erosive levels.

SECTION 7

ADDITIONAL FORMS

SIGNATURE PAGE:

[Signature]
Applicant's Signature

12/19/22
Date

THE STATE OF Texas §
County of Bexar §

BEFORE ME, the undersigned authority, on this day personally appeared Shehmir Sherali known to me to be the person whose name is subscribed to the foregoing instrument, and acknowledged to me that (s)he executed same for the purpose and consideration therein expressed.

GIVEN under my hand and seal of office on this 19 day of Dec, 2022.

[Signature]
NOTARY PUBLIC

Monica Cardenas
Typed or Printed Name of Notary

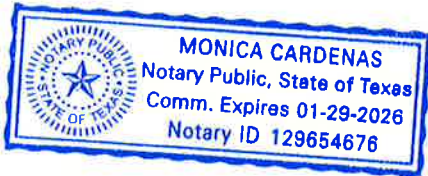

MY COMMISSION EXPIRES: 1/29/24

Application Fee Form

Texas Commission on Environmental Quality

Name of Proposed Regulated Entity: Ivy Kids of Stone Oak

Regulated Entity Location: 24278 Wilderness Oak, San Antonio, TX 78258

Name of Customer: AZEA Holdings, LLC

Contact Person: Shehmir Sherali

Phone: (210) 824-3892

Customer Reference Number (if issued):CN _____

Regulated Entity Reference Number (if issued):RN _____

Austin Regional Office (3373)

Hays

Travis

Williamson

San Antonio Regional Office (3362)

Bexar

Medina

Uvalde

Comal

Kinney

Application fees must be paid by check, certified check, or money order, payable to the **Texas Commission on Environmental Quality**. Your canceled check will serve as your receipt. **This form must be submitted with your fee payment.** This payment is being submitted to:

Austin Regional Office

San Antonio Regional Office

Mailed to: TCEQ - Cashier

Overnight Delivery to: TCEQ - Cashier

Revenues Section

12100 Park 35 Circle

Mail Code 214

Building A, 3rd Floor

P.O. Box 13088

Austin, TX 78753

Austin, TX 78711-3088

(512)239-0357

Site Location (Check All That Apply):

Recharge Zone

Contributing Zone

Transition Zone

<i>Type of Plan</i>	<i>Size</i>	<i>Fee Due</i>
Water Pollution Abatement Plan, Contributing Zone Plan: One Single Family Residential Dwelling	Acres	\$
Water Pollution Abatement Plan, Contributing Zone Plan: Multiple Single Family Residential and Parks	Acres	\$
Water Pollution Abatement Plan, Contributing Zone Plan: Non-residential	2.757 Acres	\$ 4,000
Sewage Collection System	L.F.	\$
Lift Stations without sewer lines	Acres	\$
Underground or Aboveground Storage Tank Facility	Tanks	\$
Piping System(s)(only)	Each	\$
Exception	Each	\$
Extension of Time	Each	\$

Signature: _____

Date: 12/15/22

Application Fee Schedule

Texas Commission on Environmental Quality

Edwards Aquifer Protection Program 30 TAC Chapter 213 (effective 05/01/2008)

Water Pollution Abatement Plans and Modifications

Contributing Zone Plans and Modifications

<i>Project</i>	<i>Project Area in Acres</i>	<i>Fee</i>
One Single Family Residential Dwelling	< 5	\$650
Multiple Single Family Residential and Parks	< 5	\$1,500
	5 < 10	\$3,000
	10 < 40	\$4,000
	40 < 100	\$6,500
	100 < 500	\$8,000
	≥ 500	\$10,000
Non-residential (Commercial, industrial, institutional, multi-family residential, schools, and other sites where regulated activities will occur)	< 1	\$3,000
	1 < 5	\$4,000
	5 < 10	\$5,000
	10 < 40	\$6,500
	40 < 100	\$8,000
	≥ 100	\$10,000

Organized Sewage Collection Systems and Modifications

<i>Project</i>	<i>Cost per Linear Foot</i>	<i>Minimum Fee- Maximum Fee</i>
Sewage Collection Systems	\$0.50	\$650 - \$6,500

Underground and Aboveground Storage Tank System Facility Plans and Modifications

<i>Project</i>	<i>Cost per Tank or Piping System</i>	<i>Minimum Fee- Maximum Fee</i>
Underground and Aboveground Storage Tank Facility	\$650	\$650 - \$6,500

Exception Requests

<i>Project</i>	<i>Fee</i>
Exception Request	\$500

Extension of Time Requests

<i>Project</i>	<i>Fee</i>
Extension of Time Request	\$150



TCEQ Use Only

TCEQ Core Data Form

For detailed instructions regarding completion of this form, please read the Core Data Form Instructions or call 512-239-5175.

SECTION I: General Information

1. Reason for Submission (If other is checked please describe in space provided.)		
<input checked="" type="checkbox"/> New Permit, Registration or Authorization (Core Data Form should be submitted with the program application.)		
<input type="checkbox"/> Renewal (Core Data Form should be submitted with the renewal form)	<input type="checkbox"/> Other	
2. Customer Reference Number (if issued)	Follow this link to search for CN or RN numbers in Central Registry**	3. Regulated Entity Reference Number (if issued)
CN		RN

SECTION II: Customer Information

4. General Customer Information		5. Effective Date for Customer Information Updates (mm/dd/yyyy)	
<input checked="" type="checkbox"/> New Customer		<input type="checkbox"/> Update to Customer Information	<input type="checkbox"/> Change in Regulated Entity Ownership
<input type="checkbox"/> Change in Legal Name (Verifiable with the Texas Secretary of State or Texas Comptroller of Public Accounts)			
The Customer Name submitted here may be updated automatically based on what is current and active with the Texas Secretary of State (SOS) or Texas Comptroller of Public Accounts (CPA).			
6. Customer Legal Name (If an individual, print last name first: eg: Doe, John)		<i>If new Customer, enter previous Customer below:</i>	
AZEA Holdings, LLC			
7. TX SOS/CPA Filing Number	8. TX State Tax ID (11 digits)	9. Federal Tax ID (9 digits)	10. DUNS Number (if applicable)
0803367526	32071328341	83-1978257	
11. Type of Customer:	<input type="checkbox"/> Corporation	<input type="checkbox"/> Individual	Partnership: <input type="checkbox"/> General <input type="checkbox"/> Limited
Government: <input type="checkbox"/> City <input type="checkbox"/> County <input type="checkbox"/> Federal <input type="checkbox"/> State <input type="checkbox"/> Other	<input type="checkbox"/> Sole Proprietorship	<input checked="" type="checkbox"/> Other: LLC	
12. Number of Employees		13. Independently Owned and Operated?	
<input checked="" type="checkbox"/> 0-20 <input type="checkbox"/> 21-100 <input type="checkbox"/> 101-250 <input type="checkbox"/> 251-500 <input type="checkbox"/> 501 and higher		<input checked="" type="checkbox"/> Yes <input type="checkbox"/> No	
14. Customer Role (Proposed or Actual) – as it relates to the Regulated Entity listed on this form. Please check one of the following			
<input checked="" type="checkbox"/> Owner <input type="checkbox"/> Operator <input type="checkbox"/> Owner & Operator			
<input type="checkbox"/> Occupational Licensee <input type="checkbox"/> Responsible Party <input type="checkbox"/> Voluntary Cleanup Applicant <input type="checkbox"/> Other:			
15. Mailing Address:	11010 Coachlight St, Ste. 101		
	City	San Antonio	State TX ZIP 78216 ZIP + 4 3929
16. Country Mailing Information (if outside USA)		17. E-Mail Address (if applicable)	
		shehmir@petroleumdist.com	
18. Telephone Number	19. Extension or Code	20. Fax Number (if applicable)	
(210) 824-3892		(210) 824-0544	

SECTION III: Regulated Entity Information

21. General Regulated Entity Information (If "New Regulated Entity" is selected below this form should be accompanied by a permit application)	
<input checked="" type="checkbox"/> New Regulated Entity <input type="checkbox"/> Update to Regulated Entity Name <input type="checkbox"/> Update to Regulated Entity Information	
The Regulated Entity Name submitted may be updated in order to meet TCEQ Agency Data Standards (removal of organizational endings such as Inc, LP, or LLC).	
22. Regulated Entity Name (Enter name of the site where the regulated action is taking place.)	
Ivy Kids of Stone Oak	

23. Street Address of the Regulated Entity: <i>(No PO Boxes)</i>	24272 Wilderness Oak							
	City	San Antonio	State	TX	ZIP	78258	ZIP + 4	
24. County	Bexar							

Enter Physical Location Description if no street address is provided.

25. Description to Physical Location:	Approximately 0.13 miles southwest of Wilderness Oak and Canyon Golf Road intersection.											
26. Nearest City	San Antonio				State	TX	Nearest ZIP Code		78258			
27. Latitude (N) In Decimal:	29.66551			28. Longitude (W) In Decimal:	-98.4811							
Degrees	Minutes	Seconds	Degrees	Minutes	Seconds							
29	39	55.85	-98	28	51.97							
29. Primary SIC Code (4 digits)	8351		30. Secondary SIC Code (4 digits)	5399		31. Primary NAICS Code (5 or 6 digits)	624410			32. Secondary NAICS Code (5 or 6 digits)	455219	
33. What is the Primary Business of this entity? <i>(Do not repeat the SIC or NAICS description.)</i>												
Child Day Care												
34. Mailing Address:	11010 Coachlight St, Ste. 101											
	City	San Antonio	State	TX	ZIP	78216	ZIP + 4	3929				
35. E-Mail Address:	shehmir@petroleumdist.com											
36. Telephone Number	(210) 824-3892			37. Extension or Code				38. Fax Number (if applicable)	(210) 824-544			

39. TCEQ Programs and ID Numbers Check all Programs and write in the permits/registration numbers that will be affected by the updates submitted on this form. See the Core Data Form instructions for additional guidance.

<input type="checkbox"/> Dam Safety	<input type="checkbox"/> Districts	<input checked="" type="checkbox"/> Edwards Aquifer	<input type="checkbox"/> Emissions Inventory Air	<input type="checkbox"/> Industrial Hazardous Waste
<input type="checkbox"/> Municipal Solid Waste	<input type="checkbox"/> New Source Review Air	<input type="checkbox"/> OSSF	<input type="checkbox"/> Petroleum Storage Tank	<input type="checkbox"/> PWS
<input type="checkbox"/> Sludge	<input type="checkbox"/> Storm Water	<input type="checkbox"/> Title V Air	<input type="checkbox"/> Tires	<input type="checkbox"/> Used Oil
<input type="checkbox"/> Voluntary Cleanup	<input type="checkbox"/> Waste Water	<input type="checkbox"/> Wastewater Agriculture	<input type="checkbox"/> Water Rights	<input type="checkbox"/> Other:

SECTION IV: Preparer Information

40. Name:	KLove Engineering, LLC		41. Title:	Engineer
42. Telephone Number	43. Ext./Code	44. Fax Number	45. E-Mail Address	
(210) 485-5683		() -	abarboza@kloveengineering.com	

SECTION V: Authorized Signature

46. By my signature below, I certify, to the best of my knowledge, that the information provided in this form is true and complete, and that I have signature authority to submit this form on behalf of the entity specified in Section II, Field 6 and/or as required for the updates to the ID numbers identified in field 39.

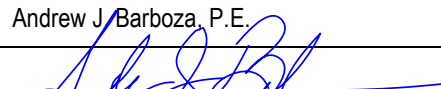
Company:	KLove Engineering, LLC	Job Title:	Senior Project Manager
Name (In Print):	Andrew J Barboza, P.E.	Phone:	(210) 485- 5683
Signature:		Date:	12/19/2022