

WATER POLLUTION ABATEMENT PLAN

April 2023

Prepared for:

Elsewhere Garden Bar & Kitchen
North of Loop1604 between Lockhill Selma &
NW Military

Prepared by:

Frank D. Corey, P.E.
Texas Professional Engineer
License No. 103068



3421 Paesanos Pkwy, Ste. 200 San Antonio Texas
78231 US
Main: 210-979-8444
Colliersengineering.com

Project No. 1082-01-02



June 21, 2023

Edwards Aquifer Group

TCEQ Region 13

14250 Judson Rd.

San Antonio, Texas 78233-4480

To Whom It May Concern,

Attached is the one (1) original and one (1) copy of the Water Pollution Abatement Plan Application for "Elsewhere Garden Bar & Kitchen" including the appropriate review fees (\$4,000). This application has been prepared according to the guidelines set forth in 30 TAC Chapter 213 Subchapter A. Please review the application for completeness and compliance with the applicable regulations for development over the Recharge Zone of the Edwards Aquifer. Upon acceptance, we request that written approval be provided to our office.

If you require additional information, please contact our office.

Sincerely,

Colliers Engineering & Design

A handwritten signature in blue ink, appearing to read "F. D. Corey". The signature is stylized and includes a horizontal line underneath the name.

Frank D. Corey, P.E.

Senior Project Manager

Attachments:

1-Original Water Pollution Abatement Plan Application

1-Copy of Water Pollution Abatement Plan Application

1-CD with PDF of WPAP

Texas Commission on Environmental Quality

Edwards Aquifer Application Cover Page

Our Review of Your Application

The Edwards Aquifer Program staff conducts an administrative and technical review of all applications. The turnaround time for administrative review can be up to 30 days as outlined in 30 TAC 213.4(e). Generally administrative completeness is determined during the intake meeting or within a few days of receipt. The turnaround time for technical review of an administratively complete Edwards Aquifer application is 90 days as outlined in 30 TAC 213.4(e). Please know that the review and approval time is directly impacted by the quality and completeness of the initial application that is received. In order to conduct a timely review, it is imperative that the information provided in an Edwards Aquifer application include final plans, be accurate, complete, and in compliance with [30 TAC 213](#).

Administrative Review

1. [Edwards Aquifer applications](#) must be deemed administratively complete before a technical review can begin. To be considered administratively complete, the application must contain completed forms and attachments, provide the requested information, and meet all the site plan requirements. The submitted application and plan sheets should be final plans. Please submit one full-size set of plan sheets with the original application, and half-size sets with the additional copies.

To ensure that all applicable documents are included in the application, the program has developed tools to guide you and web pages to provide all forms, checklists, and guidance. Please visit the below website for assistance: <http://www.tceq.texas.gov/field/eapp>.

2. This Edwards Aquifer Application Cover Page form (certified by the applicant or agent) must be included in the application and brought to the administrative review meeting.
3. Administrative reviews are scheduled with program staff who will conduct the review. Applicants or their authorized agent should call the appropriate regional office, according to the county in which the project is located, to schedule a review. The average meeting time is one hour.
4. In the meeting, the application is examined for administrative completeness. Deficiencies will be noted by staff and emailed or faxed to the applicant and authorized agent at the end of the meeting, or shortly after. Administrative deficiencies will cause the application to be deemed incomplete and returned.

An appointment should be made to resubmit the application. The application is re-examined to ensure all deficiencies are resolved. The application will only be deemed administratively complete when all administrative deficiencies are addressed.

5. If an application is received by mail, courier service, or otherwise submitted without a review meeting, the administrative review will be conducted within 30 days. The applicant and agent will be contacted with the results of the administrative review. If the application is found to be administratively incomplete, it can be retrieved from the regional office or returned by regular mail. If returned by mail, the regional office may require arrangements for return shipping.
6. If the geologic assessment was completed before October 1, 2004 and the site contains “possibly sensitive” features, the assessment must be updated in accordance with the *Instructions to Geologists* (TCEQ-0585 Instructions).

Technical Review

1. When an application is deemed administratively complete, the technical review period begins. The regional office will distribute copies of the application to the identified affected city, county, and groundwater conservation district whose jurisdiction includes the subject site. These entities and the public have 30 days to provide comments on the application to the regional office. All comments received are reviewed by TCEQ.
2. A site assessment is usually conducted as part of the technical review, to evaluate the geologic assessment and observe existing site conditions. The site must be accessible to our staff. The site boundaries should be

clearly marked, features identified in the geologic assessment should be flagged, roadways marked and the alignment of the Sewage Collection System and manholes should be staked at the time the application is submitted. If the site is not marked the application may be returned.

3. We evaluate the application for technical completeness and contact the applicant and agent via Notice of Deficiency (NOD) to request additional information and identify technical deficiencies. There are two deficiency response periods available to the applicant. There are 14 days to resolve deficiencies noted in the first NOD. If a second NOD is issued, there is an additional 14 days to resolve deficiencies. If the response to the second notice is not received, is incomplete or inadequate, or provides new information that is incomplete or inadequate, the application must be withdrawn or will be denied. Please note that because the technical review is underway, whether the application is withdrawn or denied **the application fee will be forfeited**.
4. The program has 90 calendar days to complete the technical review of the application. If the application is technically adequate, such that it complies with the Edwards Aquifer rules, and is protective of the Edwards Aquifer during and after construction, an approval letter will be issued. Construction or other regulated activity may not begin until an approval is issued.

Mid-Review Modifications

It is important to have final site plans prior to beginning the permitting process with TCEQ to avoid delays.

Occasionally, circumstances arise where you may have significant design and/or site plan changes after your Edwards Aquifer application has been deemed administratively complete by TCEQ. This is considered a “Mid-Review Modification”. Mid-Review Modifications may require redistribution of an application that includes the proposed modifications for public comment.

If you are proposing a Mid-Review Modification, two options are available:

- If the technical review has begun your application can be denied/withdrawn, your fees will be forfeited, and the plan will have to be resubmitted.
- TCEQ can continue the technical review of the application as it was submitted, and a modification application can be submitted at a later time.

If the application is denied/withdrawn, the resubmitted application will be subject to the administrative and technical review processes and will be treated as a new application. The application will be redistributed to the affected jurisdictions.

Please contact the regional office if you have questions. If your project is located in Williamson, Travis, or Hays County, contact TCEQ’s Austin Regional Office at 512-339-2929. If your project is in Comal, Bexar, Medina, Uvalde, or Kinney County, contact TCEQ’s San Antonio Regional Office at 210-490-3096

Please fill out all required fields below and submit with your application.

1. Regulated Entity Name: Elsewhere Garden Bar and Kitchen					2. Regulated Entity No.:				
3. Customer Name: Terrin Fuhrmann					4. Customer No.:				
5. Project Type: (Please circle/check one)		<input checked="" type="radio"/> New	Modification		Extension		Exception		
6. Plan Type: (Please circle/check one)		<input checked="" type="radio"/> WPAP	<input type="radio"/> CZP	<input type="radio"/> SCS	<input type="radio"/> UST	<input type="radio"/> AST	<input type="radio"/> EXP	<input type="radio"/> EXT	Technical Clarification Optional Enhanced Measures
7. Land Use: (Please circle/check one)		<input type="radio"/> Residential	<input checked="" type="radio"/> Non-residential			8. Site (acres):		4.32	
9. Application Fee:		\$4,000		10. Permanent BMP(s):			Contech Jellyfish		
11. SCS (Linear Ft.):		N/A		12. AST/UST (No. Tanks):					
13. County:		Bexar		14. Watershed:			Upper San Antonio Watershed		

Application Distribution

Instructions: Use the table below to determine the number of applications required. One original and one copy of the application, plus additional copies (as needed) for each affected incorporated city, county, and groundwater conservation district are required. Linear projects or large projects, which cross into multiple jurisdictions, can require additional copies. Refer to the “Texas Groundwater Conservation Districts within the EAPP Boundaries” map found at:

http://www.tceq.texas.gov/assets/public/compliance/field_ops/eapp/EAPP%20GWCD%20map.pdf

For more detailed boundaries, please contact the conservation district directly.

Austin Region			
County:	Hays	Travis	Williamson
Original (1 req.)	—	—	—
Region (1 req.)	—	—	—
County(ies)	—	—	—
Groundwater Conservation District(s)	<input type="checkbox"/> Edwards Aquifer Authority <input type="checkbox"/> Barton Springs/ Edwards Aquifer <input type="checkbox"/> Hays Trinity <input type="checkbox"/> Plum Creek	<input type="checkbox"/> Barton Springs/ Edwards Aquifer	NA
City(ies) Jurisdiction	<input type="checkbox"/> Austin <input type="checkbox"/> Buda <input type="checkbox"/> Dripping Springs <input type="checkbox"/> Kyle <input type="checkbox"/> Mountain City <input type="checkbox"/> San Marcos <input type="checkbox"/> Wimberley <input type="checkbox"/> Woodcreek	<input type="checkbox"/> Austin <input type="checkbox"/> Bee Cave <input type="checkbox"/> Pflugerville <input type="checkbox"/> Rollingwood <input type="checkbox"/> Round Rock <input type="checkbox"/> Sunset Valley <input type="checkbox"/> West Lake Hills	<input type="checkbox"/> Austin <input type="checkbox"/> Cedar Park <input type="checkbox"/> Florence <input type="checkbox"/> Georgetown <input type="checkbox"/> Jerrell <input type="checkbox"/> Leander <input type="checkbox"/> Liberty Hill <input type="checkbox"/> Pflugerville <input type="checkbox"/> Round Rock

San Antonio Region					
County:	Bexar	Comal	Kinney	Medina	Uvalde
Original (1 req.)	<input checked="" type="checkbox"/>	—	—	—	—
Region (1 req.)	<input checked="" type="checkbox"/>	—	—	—	—
County(ies)	<input checked="" type="checkbox"/>	—	—	—	—
Groundwater Conservation District(s)	<input checked="" type="checkbox"/> Edwards Aquifer Authority <input checked="" type="checkbox"/> Trinity-Glen Rose	<input type="checkbox"/> Edwards Aquifer Authority	<input type="checkbox"/> Kinney	<input type="checkbox"/> EAA <input type="checkbox"/> Medina	<input type="checkbox"/> EAA <input type="checkbox"/> Uvalde
City(ies) Jurisdiction	<input type="checkbox"/> Castle Hills <input type="checkbox"/> Fair Oaks Ranch <input type="checkbox"/> Helotes <input type="checkbox"/> Hill Country Village <input type="checkbox"/> Hollywood Park <input checked="" type="checkbox"/> San Antonio (SAWS) <input type="checkbox"/> Shavano Park	<input type="checkbox"/> Bulverde <input type="checkbox"/> Fair Oaks Ranch <input type="checkbox"/> Garden Ridge <input type="checkbox"/> New Braunfels <input type="checkbox"/> Schertz	NA	<input type="checkbox"/> San Antonio ETJ (SAWS)	NA

I certify that to the best of my knowledge, that the application is complete and accurate. This application is hereby submitted to TCEQ for administrative review and technical review.

Terrin Fuhrmann

Terrin Fuhrmann

Print Name of Customer/Authorized Agent

4-27-23

Signature of Customer/Authorized Agent

Date

****FOR TCEQ INTERNAL USE ONLY****

Date(s) Reviewed:		Date Administratively Complete:	
Received From:		Correct Number of Copies:	
Received By:		Distribution Date:	
EAPP File Number:		Complex:	
Admin. Review(s) (No.):		No. AR Rounds:	
Delinquent Fees (Y/N):		Review Time Spent:	
Lat./Long. Verified:		SOS Customer Verification:	
Agent Authorization Complete/Notarized (Y/N):		Fee Check:	Payable to TCEQ (Y/N):
Core Data Form Complete (Y/N):			Signed (Y/N):
Core Data Form Incomplete Nos.:			Less than 90 days old (Y/N):

Table of Contents

GENERAL INFORMATION	SECTION 1
GENERAL INFORMATION FORM	TCEQ-0587
Road Map.....	Attachment A
USGS/EARZ Exhibit.....	Attachment B
Project Description.....	Attachment C
GEOLOGIC ASSESSMENT	SECTION 2
GEOLOGIC ASSESSMENT FORM	TCEQ-0585
Geologic Assessment Table.....	Attachment A
Stratigraphic Column.....	Attachment B
Narrative of Geologic Assessment.....	Attachment C
Site Soils Map & Geologic Map.....	Attachment D
WATER POLLUTION ABATEMENT PLAN	SECTION 3
WATER POLLUTION ABATEMENT PLAN APPLICATION FORM	TCEQ-0584
Factors Affecting Water Quality.....	Attachment A
Volume and Character of Storm Water	Attachment B
Suitability Letter from Authorized Agent.....	Attachment C
Exception to the Required Geologic Assessment	Attachment D
TEMPORARY STORMWATER	SECTION 4
TEMPORARY STORMWATER FORM	TCEQ-0602
Spill Response Actions.....	Attachment A
Potential Sources of Contamination	Attachment B
Sequence of Major Activities.....	Attachment C
Temporary Best Management Practices and Measures.....	Attachment D
Request to Temporarily Seal a Feature.....	Attachment E
Structural Practices.....	Attachment F
Drainage Area Map.....	Attachment G
Temporary Sediment Pond(s) Plans and Calculations.....	Attachment H
Inspection and Maintenance for BMPs.....	Attachment I
Schedule of Interim and Permanent Soil Stabilization Practices.....	Attachment J
PERMANENT STORMWATER	SECTION 5
PERMANENT STORMWATER FORM	TCEQ-0600
20% or Less Impervious Cover Waiver.....	Attachment A
BMPs for Upgradient Stormwater.....	Attachment B
BMPs for On-site Stormwater.....	Attachment C
BMPs for Surface Streams.....	Attachment D
Request to Seal Features.....	Attachment E
Construction Plans.....	Attachment F
Inspection and Maintenance Plan	Attachment G
Pilot-Scale Field Testing Plan	Attachment H
Measures for Minimizing Surface Stream Contamination.....	Attachment I
ADDITIONAL FORMS	SECTION 6
AGENT AUTHORIZATION FORM	TCEQ-0599
APPLICATION FEE FORM.....	TCEQ-0574
Check Payable to the "Texas Commission on Environmental Quality"	
CORE DATA FORM.....	TCEQ-10400
EXHIBITS	SECTION 7
WPAP SITE PLAN	EXHIBIT 1
WATER QUALITY PLAN & DETAILS	EXHIBIT 2
EXISTING & PROPOSED DRAINAGE MAPS	EXHIBIT 3
RECORDED WARRANTY DEEDS.....	EXHIBIT 4

GENERAL INFORMATION

General Information Form

Texas Commission on Environmental Quality

For Regulated Activities on the Edwards Aquifer Recharge and Transition Zones and Relating to 30 TAC §213.4(b) & §213.5(b)(2)(A), (B) Effective June 1, 1999

To ensure that the application is administratively complete, confirm that all fields in the form are complete, verify that all requested information is provided, consistently reference the same site and contact person in all forms in the application, and ensure forms are signed by the appropriate party.

Note: Including all the information requested in the form and attachments contributes to more streamlined technical reviews.

Signature

To the best of my knowledge, the responses to this form accurately reflect all information requested concerning the proposed regulated activities and methods to protect the Edwards Aquifer. This **General Information Form** is hereby submitted for TCEQ review. The application was prepared by:

Print Name of Customer/Agent: Frank D. Corey, PE

Date: 06/22/2023

Signature of Customer/Agent:



Project Information

1. Regulated Entity Name: Elsewhere Garden Bar & Kitchen
2. County: Bexar
3. Stream Basin: Upper San Antonio Watershed
4. Groundwater Conservation District (If applicable): Trinity Glen Rose GCD and Edwards Aquifer Authority
5. Edwards Aquifer Zone:
 Recharge Zone
 Transition Zone
6. Plan Type:
 WPAP
 SCS
 Modification
 AST

UST

Exception Request

7. Customer (Applicant):

Contact Person: Terrin Fuhrmann

Entity: Elsewhere Garden Bar & Kitchen

Mailing Address: 110 N. Manton Ln.

City, State: San Antonio, TX

Zip: 78213

Telephone: 210-393-0511

FAX: _____

Email Address: terrinfuhrmann@yahoo.com

8. Agent/Representative (If any):

Contact Person: Frank D. Corey, PE

Entity: Colliers Engineering & Design

Mailing Address: 3421 Paesanos Pkwy, Suite 200

City, State: San Antonio, TX

Zip: 78231-4406

Telephone: 726-223-4992

FAX: _____

Email Address: frank.corey@collierseng.com

9. Project Location:

The project site is located inside the city limits of San Antonio.

The project site is located outside the city limits but inside the ETJ (extra-territorial jurisdiction) of _____.

The project site is not located within any city's limits or ETJ.

10. The location of the project site is described below. The description provides sufficient detail and clarity so that the TCEQ's Regional staff can easily locate the project and site boundaries for a field investigation.

From the TCEQ office take Judson Rd North until you get to 1604. Go West on 1604 for about 11 miles. The site is located North of Loop 1604 between Lockhil Selma and NW Military

11. **Attachment A – Road Map.** A road map showing directions to and the location of the project site is attached. The project location and site boundaries are clearly shown on the map.

12. **Attachment B - USGS / Edwards Recharge Zone Map.** A copy of the official 7 ½ minute USGS Quadrangle Map (Scale: 1" = 2000') of the Edwards Recharge Zone is attached. The map(s) clearly show:

Project site boundaries.

USGS Quadrangle Name(s).

Boundaries of the Recharge Zone (and Transition Zone, if applicable).

Drainage path from the project site to the boundary of the Recharge Zone.

13. **The TCEQ must be able to inspect the project site or the application will be returned.** Sufficient survey staking is provided on the project to allow TCEQ regional staff to locate

the boundaries and alignment of the regulated activities and the geologic or manmade features noted in the Geologic Assessment.

Survey staking will be completed by this date: Completed

14. **Attachment C – Project Description.** Attached at the end of this form is a detailed narrative description of the proposed project. The project description is consistent throughout the application and contains, at a minimum, the following details:

- Area of the site
- Offsite areas
- Impervious cover
- Permanent BMP(s)
- Proposed site use
- Site history
- Previous development
- Area(s) to be demolished

15. Existing project site conditions are noted below:

- Existing commercial site
- Existing industrial site
- Existing residential site
- Existing paved and/or unpaved roads
- Undeveloped (Cleared)
- Undeveloped (Undisturbed/Uncleared)
- Other: _____

Prohibited Activities

16. I am aware that the following activities are prohibited on the Recharge Zone and are not proposed for this project:

- (1) Waste disposal wells regulated under 30 TAC Chapter 331 of this title (relating to Underground Injection Control);
- (2) New feedlot/concentrated animal feeding operations, as defined in 30 TAC §213.3;
- (3) Land disposal of Class I wastes, as defined in 30 TAC §335.1;
- (4) The use of sewage holding tanks as parts of organized collection systems; and
- (5) New municipal solid waste landfill facilities required to meet and comply with Type I standards which are defined in §330.41(b), (c), and (d) of this title (relating to Types of Municipal Solid Waste Facilities).
- (6) New municipal and industrial wastewater discharges into or adjacent to water in the state that would create additional pollutant loading.

17. I am aware that the following activities are prohibited on the Transition Zone and are not proposed for this project:

- (1) Waste disposal wells regulated under 30 TAC Chapter 331 (relating to Underground Injection Control);
- (2) Land disposal of Class I wastes, as defined in 30 TAC §335.1; and
- (3) New municipal solid waste landfill facilities required to meet and comply with Type I standards which are defined in §330.41 (b), (c), and (d) of this title.



Administrative Information

18. The fee for the plan(s) is based on:

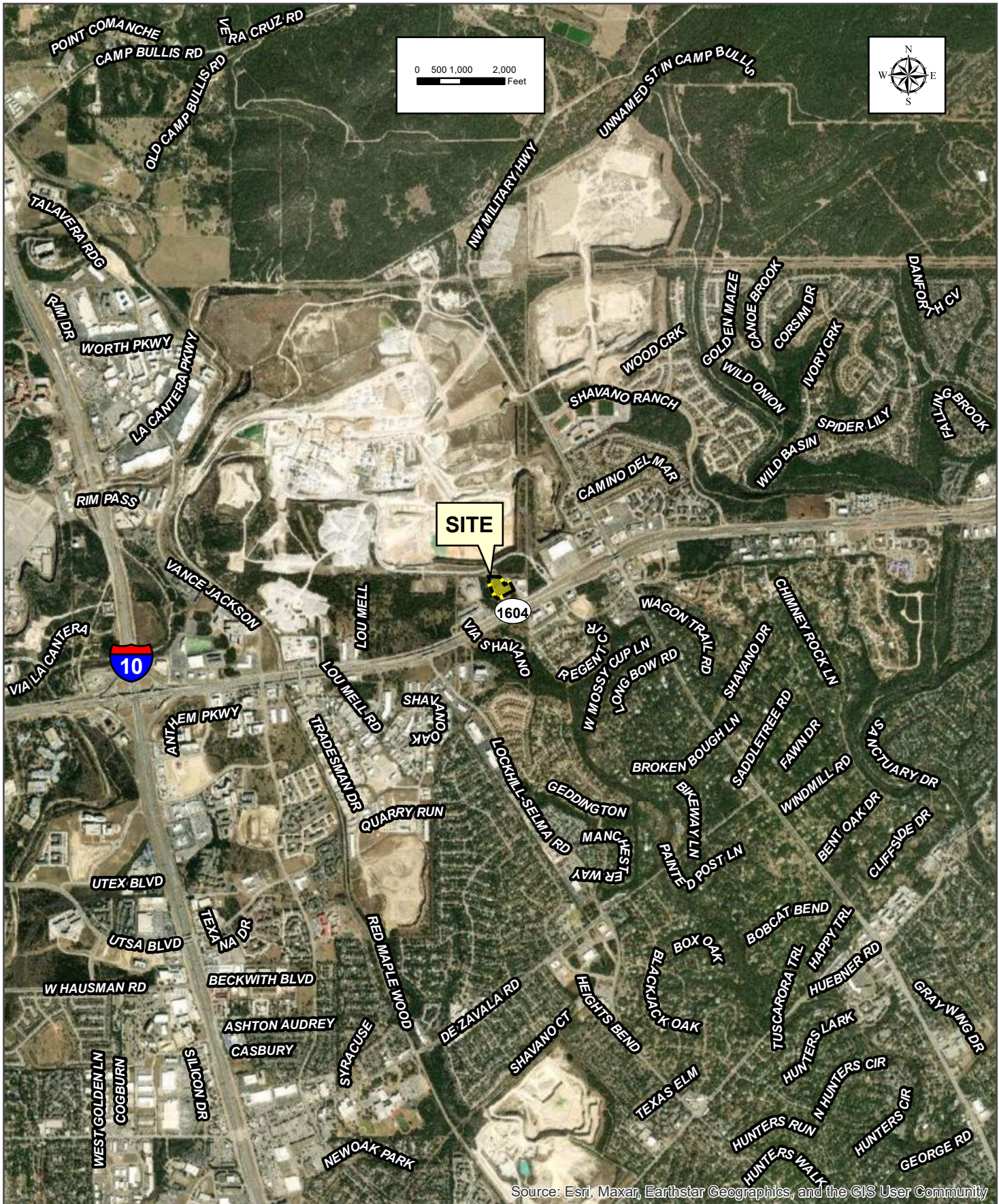
- For a Water Pollution Abatement Plan or Modification, the total acreage of the site where regulated activities will occur.
 - For an Organized Sewage Collection System Plan or Modification, the total linear footage of all collection system lines.
 - For a UST Facility Plan or Modification or an AST Facility Plan or Modification, the total number of tanks or piping systems.
 - A request for an exception to any substantive portion of the regulations related to the protection of water quality.
 - A request for an extension to a previously approved plan.
19. Application fees are due and payable at the time the application is filed. If the correct fee is not submitted, the TCEQ is not required to consider the application until the correct fee is submitted. Both the fee and the Edwards Aquifer Fee Form have been sent to the Commission's:
- TCEQ cashier
 - Austin Regional Office (for projects in Hays, Travis, and Williamson Counties)
 - San Antonio Regional Office (for projects in Bexar, Comal, Kinney, Medina, and Uvalde Counties)
20. Submit one (1) original and one (1) copy of the application, plus additional copies as needed for each affected incorporated city, groundwater conservation district, and county in which the project will be located. The TCEQ will distribute the additional copies to these jurisdictions. The copies must be submitted to the appropriate regional office.
21. No person shall commence any regulated activity until the Edwards Aquifer Protection Plan(s) for the activity has been filed with and approved by the Executive Director.



Source: Esri, Maxar, Earthstar Geographics, and the GIS User Community

Prepared For: Terrin Fuhrmann	<h2>Road Map</h2> <h3>Elsewhere Garden Bar & Kitchen</h3>		<h2>ATTACHMENT A</h2>
Prepared By: San Antonio Office 3421 Paesanos Pkwy San Antonio, TX T: 877.627.3772 www.colliersengineering.com	 Colliers Engineering & Design		LEGEND  Site
	Date: 5/19/2023	Project #: 1082-01-02	Drawn By: mcruz

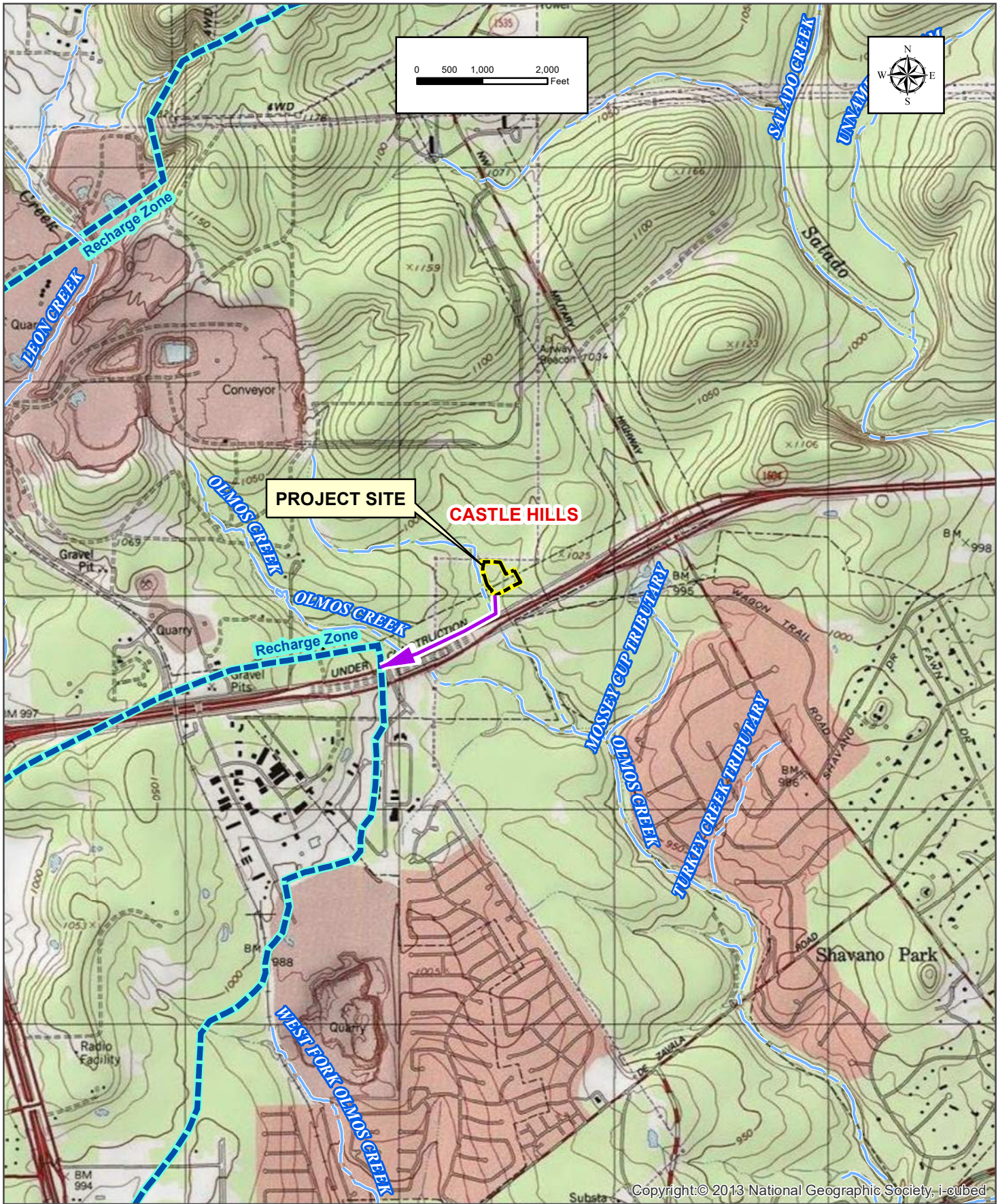

Copyright © 2013 National Geographic Society, i-cubed

Prepared For:
Terrin Fuhrmann

Prepared By:
San Antonio Office
3421 Paesanos Pkwy
San Antonio, TX
T: 877.627.3772
www.colliersengineering.com







**USGS Quadrangle - Castle Hill/
Edwards Aquifer Recharge Zone**

Elsewhere Garden Bar & Kitchen
San Antonio, Bexar County, Texas

Date: 6/23/2023	Project #: 1082-01-02	Drawn By: mcruz
--------------------	--------------------------	--------------------

ATTACHMENT B

LEGEND

-  Project Site
-  Drainage Path
-  Creeks
-  Edwards Aquifer Recharge Zone

Project Description

The Elsewhere Garden Bar & Kitchen is an undeveloped 4.32 acre tract that lies within the City of San Antonio, TX, and is located within the Edwards Aquifer Recharge Zone and the Upper San Antonio Watershed. Project wastewater will be disposed of to the existing Dos Rios Wastewater Treatment Plant.

The project site will be developed into an outdoor seating area with a Bar, Kitchen, Stage, and Event Pavilion. Parking areas, access drives, storm drain, and utilities will be constructed. The total 4.32-acre project area consists of 4.127-acre lot (Lot 7, Block 1, NCB 17700) and approximately 0.193 acres of off-site area. The construction of the proposed development will result in an increase of 1.622 acres (37.47%) of impervious cover. The required total suspended solids (TSS) treatment for this project is 1,324 pounds of TSS generated from the 1.622 acres of proposed impervious cover. The removal efficiency of the proposed runoff will meet the required overall removal of 86% increase in TSS. See **Exhibit 3** for Existing/Proposed Drainage areas.

It is anticipated that 4.32 acres will be disturbed by the construction activities. These activities will be subjected to TPDES requirements. A Storm Water Pollution Prevention Plan will be maintained for the site and temporary BMP's will be implemented to prevent erosion and sedimentation until completion of the permanent BMP. The temporary BMP's for the construction activities will include: silt fence, rock berms, tree protection, stabilized construction entrance/exit, inlet and concrete washout area. All on-site temporary BMP's will be designed in accordance with the TCEQ Technical Guidance Manual.

Lastly, there will not be any storage of regulated quantities of hazardous materials on-site.

GEOLOGIC ASSESSMENT SECTION

Geologic Assessment

Texas Commission on Environmental Quality

For Regulated Activities on The Edwards Aquifer Recharge/transition Zones and Relating to 30 TAC §213.5(b)(3), Effective June 1, 1999

To ensure that the application is administratively complete, confirm that all fields in the form are complete, verify that all requested information is provided, consistently reference the same site and contact person in all forms in the application, and ensure forms are signed by the appropriate party.

Note: Including all the information requested in the form and attachments contributes to more streamlined technical reviews.

Signature

To the best of my knowledge, the responses to this form accurately reflect all information requested concerning the proposed regulated activities and methods to protect the Edwards Aquifer. My signature certifies that I am qualified as a geologist as defined by 30 TAC Chapter 213.

Print Name of Geologist: Roman C. Pineda,
P.G.

Telephone: (210) 979-8444

Fax: (210) 979-8441

Date: 12/6/2022

Representing: KFW Engineers, TBPE Firm #9513 (Name of Company and TBPG or TBPE registration number)

Signature of Geologist:

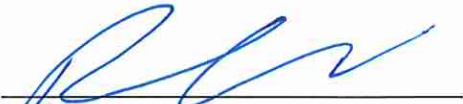

Regulated Entity Name: Elsewhere Garden Bar & Kitchen (Ridge East)

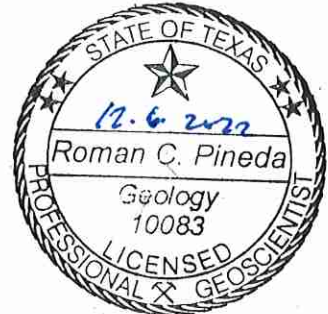

Project Information

1. Date(s) Geologic Assessment was performed: November 22, 2022

2. Type of Project:

WPAP
 SCS

AST
 UST

3. Location of Project:

Recharge Zone
 Transition Zone
 Contributing Zone within the Transition Zone

4. **Attachment A - Geologic Assessment Table.** Completed Geologic Assessment Table (Form TCEQ-0585-Table) is attached.
5. Soil cover on the project site is summarized in the table below and uses the SCS Hydrologic Soil Groups* (Urban Hydrology for Small Watersheds, Technical Release No. 55, Appendix A, Soil Conservation Service, 1986). If there is more than one soil type on the project site, show each soil type on the site Geologic Map or a separate soils map.

Table 1 - Soil Units, Infiltration Characteristics and Thickness

Soil Name	Group*	Thickness(feet)
Crawford, stony and Bexar soils, 0 to 5 percent slopes (Cb)	D	0-3

Soil Name	Group*	Thickness(feet)

** Soil Group Definitions (Abbreviated)*

- A. Soils having a high infiltration rate when thoroughly wetted.
- B. Soils having a moderate infiltration rate when thoroughly wetted.
- C. Soils having a slow infiltration rate when thoroughly wetted.
- D. Soils having a very slow infiltration rate when thoroughly wetted.

6. **Attachment B – Stratigraphic Column.** A stratigraphic column showing formations, members, and thicknesses is attached. The outcropping unit, if present, should be at the top of the stratigraphic column. Otherwise, the uppermost unit should be at the top of the stratigraphic column.
7. **Attachment C – Site Geology.** A narrative description of the site specific geology including any features identified in the Geologic Assessment Table, a discussion of the potential for fluid movement to the Edwards Aquifer, stratigraphy, structure(s), and karst characteristics is attached.
8. **Attachment D – Site Geologic Map(s).** The Site Geologic Map must be the same scale as the applicant's Site Plan. The minimum scale is 1": 400'
 Applicant's Site Plan Scale: 1" = 30'
 Site Geologic Map Scale: 1" = 30'
 Site Soils Map Scale (if more than 1 soil type): 1" = N/A'
9. Method of collecting positional data:
 - Global Positioning System (GPS) technology.
 - Other method(s). Please describe method of data collection: _____

10. The project site and boundaries are clearly shown and labeled on the Site Geologic Map.
11. Surface geologic units are shown and labeled on the Site Geologic Map.
12. Geologic or manmade features were discovered on the project site during the field investigation. They are shown and labeled on the Site Geologic Map and are described in the attached Geologic Assessment Table.
- Geologic or manmade features were not discovered on the project site during the field investigation.
13. The Recharge Zone boundary is shown and labeled, if appropriate.
14. All known wells (test holes, water, oil, unplugged, capped and/or abandoned, etc.): If applicable, the information must agree with Item No. 20 of the WPAP Application Section.
- There are _ (#) wells present on the project site and the locations are shown and labeled. (Check all of the following that apply.)
- The wells are not in use and have been properly abandoned.
- The wells are not in use and will be properly abandoned.
- The wells are in use and comply with 16 TAC Chapter 76.
- There are no wells or test holes of any kind known to exist on the project site.

Administrative Information

15. Submit one (1) original and one (1) copy of the application, plus additional copies as needed for each affected incorporated city, groundwater conservation district, and county in which the project will be located. The TCEQ will distribute the additional copies to these jurisdictions. The copies must be submitted to the appropriate regional office.

ELSEWHERE GARDEN BAR & KITCHEN (RIDGE EAST)

Stratigraphic Column

[Hydrogeologic subdivisions modified from Maclay and Small (1976); groups, formations, and members modified from Rose (1972); lithology modified from Dunham (1962); and porosity type modified from Choquette and Pray (1970). CU, confining unit; AQ, aquifer]

Hydrogeologic subdivision		Group, formation, or member	Hydro-logic function	Thickness (feet)	Lithology	Field identification	Cavern development	Porosity/permeability type		
Upper Cretaceous	Upper confining units	Eagle Ford Group	CU	30 – 50	Brown, flaggy shale and argillaceous limestone	Thin flagstones; petroliferous	None	Primary porosity lost/ low permeability		
		Buda Limestone	CU	40 – 50	Buff, light gray, dense mudstone	Porcelaneous limestone with calcite-filled veins	Minor surface karst	Low porosity/low permeability		
		Del Rio Clay	CU	40 – 50	Blue-green to yellow-brown clay	Fossiliferous; <i>Ilymatogyra arietina</i>	None	None/primary upper confining unit		
Lower Cretaceous	Edwards aquifer	Georgetown Formation	Karst AQ; not karst CU	2 – 20	Reddish-brown, gray to light tan marly limestone	Marker fossil; <i>Waconella wacoensis</i>	None	Low porosity/low permeability		
									Edwards Group	Person Formation
		Leached and collapsed members, undivided	AQ	70 – 90	Crystalline limestone; mudstone to grainstone; chert; collapsed breccia	Bioturbated iron-stained beds separated by massive limestone beds; stromatolitic limestone	Extensive lateral development; large rooms	Majority not fabric/one of the most permeable		
		Regional dense member	CU	20 – 24	Dense, argillaceous mudstone	Wispy iron-oxide stains	Very few; only vertical fracture enlargement	Not fabric/low permeability; vertical barrier		
		Kainer Formation	Grainstone member	AQ	50 – 60	<i>Miliolid</i> grainstone; mudstone to wackestone; chert	White crossbedded grainstone	Few		Not fabric/ recrystallization reduces permeability
			Kirschberg evaporite member	AQ	50 – 60	Highly altered crystalline limestone; chalky mudstone; chert	Boxwork voids, with neospar and travertine frame	Probably extensive cave development		Majority fabric/one of the most permeable
			Dolomitic member	AQ	110 – 130	Mudstone to grainstone; crystalline limestone; chert	Massively bedded light gray, <i>Toucasia</i> abundant	Caves related to structure or bedding planes		Mostly not fabric; some bedding plane-fabric/water-yielding
			Basal nodular member	Karst AQ; not karst CU	50 – 60	Shaly, nodular limestone; mudstone and <i>miliolid</i> grainstone	Massive, nodular and mottled, <i>Exogyra texana</i>	Large lateral caves at surface; a few caves near Cibolo Creek		Fabric; stratigraphically controlled/large conduit flow at surface; no permeability in subsurface
		Lower confining unit	Upper member of the Glen Rose Limestone	CU; evaporite beds AQ	350 – 500	Yellowish tan, thinly bedded limestone and marl	Stair-step topography; alternating limestone and marl	Some surface cave development	Some water production at evaporite beds/relatively impermeable	

Source: Stein and Ozuna, 1996, U.S. Geological Survey WRIR 95-4030.

ELSEWHERE GARDEN BAR & KITCHEN (RIDGE EAST)

Narrative Description of Site Geology

The overall potential for fluid migration to the Edwards Aquifer on the site is low to moderate. This site is located within outcrop areas of the Del Rio Clay (Kdr), Georgetown Formation (Kgt) and the cyclic and marine members of the Person Formation (Kep). Fill material has placed on a large area on the eastern half of the site. The dominant trend for the site is N60°E, based on an average of the trends of faults within the surrounding area and from published maps (Stein & Ozuna, 1995).

The Del Rio Clay is characterized by yellow-brown clay. The Georgetown Formation is characterized by gray to light tan marly limestone. The cyclic and marine members of the Person Formation are characterized by a mudstone to packstone milliolid grainstone with chert. No karst development occurs within the Del Rio Clay and Georgetown Formation. Karst development in the cyclic and marine members of the Person Formation is characterized by small sinkholes and caves formed as vertical shafts as well as lateral rooms.

Feature S-1

Feature is a solution cavity within bedrock. Loose organics, coarse cobbles and some organic fines were observed within the void. The probability of rapid infiltration is high.

The following significant recharge features were identified on site.

Features S-2 and S-3

Features are non-karst closed depressions surrounding oak trees as a result of placing fill material within a large area of the site. Due to fine infilling and lack of karst origin, the probability of rapid infiltration is low.

Feature S-4

Feature is a fault mapped by field evidence and aerial photograph review. The fault juxtaposes the Person Formation with the Del Rio Clay and Georgetown Formation. Due to fine infilling and no field evidence of enhanced permeability, the probability of rapid infiltration is low.

Date: Dec 06, 2022, 4:33pm User ID: rphedp
 File: K:\1082\01\Design\Environmental\GA\Elsewhere\GIS\RCP revised Elsewhere Garden Kitchen GA-WPAP-Xyrev.dwg

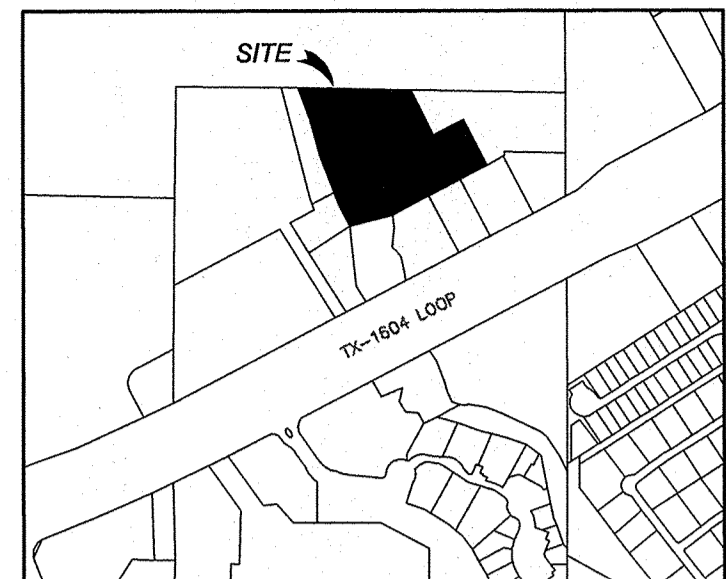
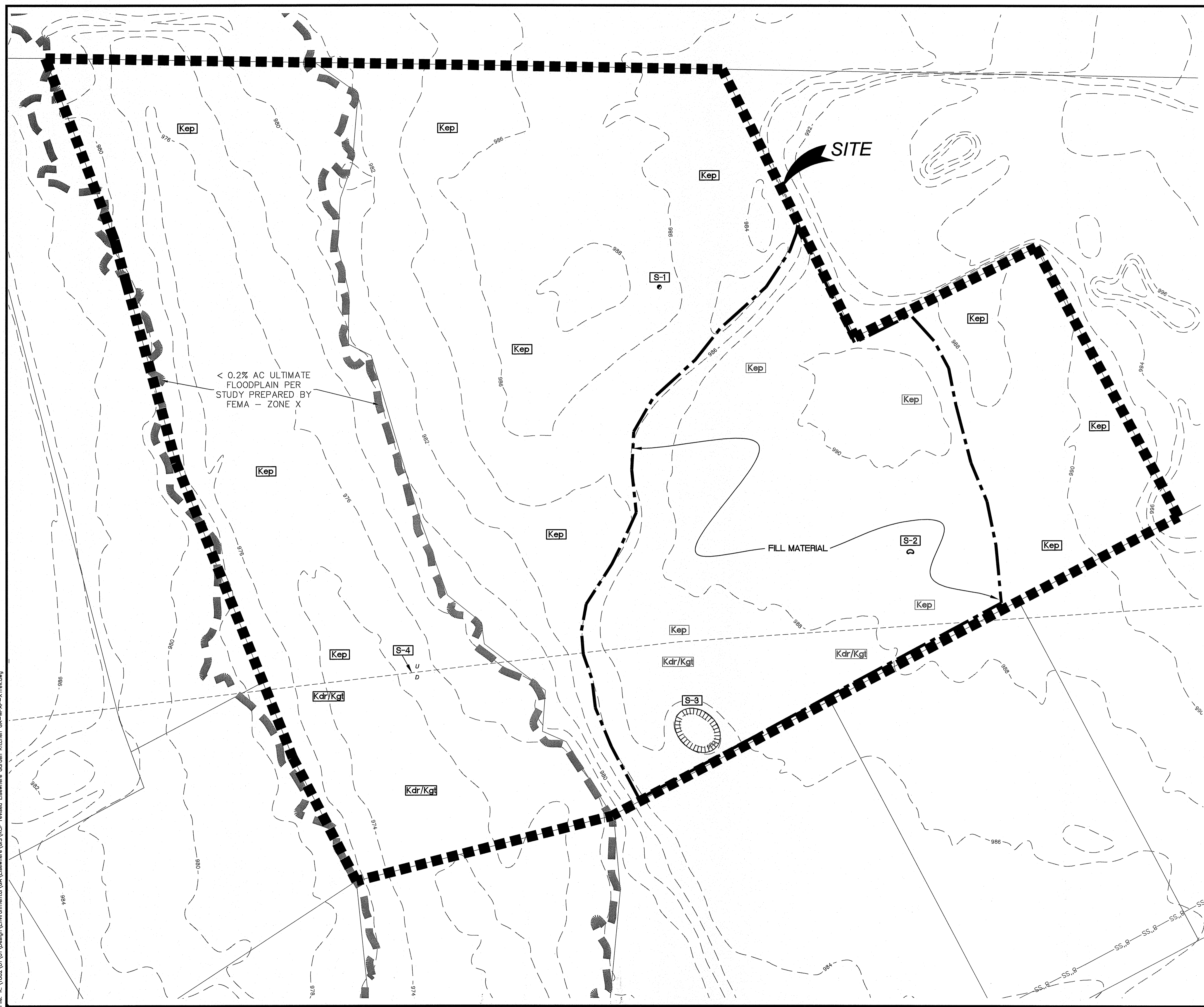

LOCATION MAP
N.T.S.

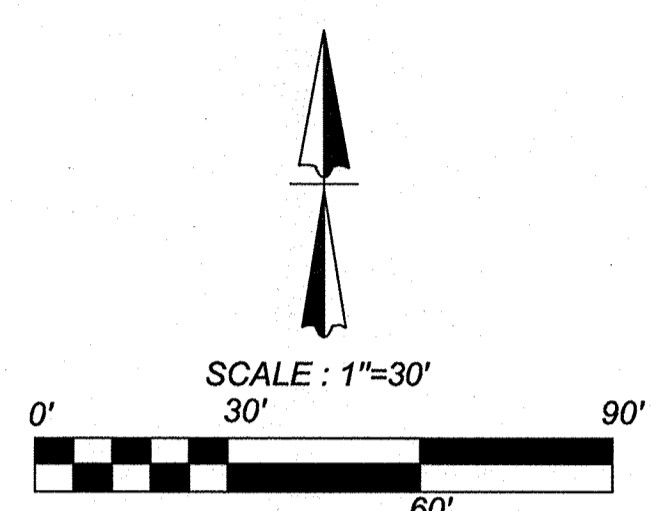

LEGEND

	ALLUVIUM
	BUDA LIMESTONE
	DEL RIO CLAY
	GEORGETOWN FORMATION
	PERSON FORMATION
	KAINER FORMATION
	GLEN ROSE FORMATION
	POTENTIAL RECHARGE FEATURE
	DRAINAGE PATHWAY
	CONTACT, LOCATED APPROXIMATELY
	FAULT, LOCATED APPROXIMATELY (D, DOWNTHROWN SIDE; U, UPTHROWN SIDE)
	FAULT EXISTENCE UNCERTAIN
	POSSIBLE FAULT (AS LOCATED BY AERIAL PHOTOGRAPHS)
	STRIKE AND DIP OF BEDDING
	STRIKE AND DIP OF JOINTS
	STRIKE OF VERTICAL JOINTS
	CAVE
	NON-KARST CLOSED DEPRESSION
	SWALLOW HOLE
	SOLUTION CAVITY
	OTHER NATURAL BEDROCK FEATURES: VUGGY ROCK, REEF DEPOSITS
	ZONE
	MAN-MADE FEATURE IN BEDROCK
	WATER WELL
	PROPOSED SANITARY SEWER LINE
	EXISTING SANITARY SEWER LINE
	50' SEWER ENVELOPE
	PROPOSED MANHOLE
	EXISTING MANHOLE

NOTE: THE GEOSCIENTIST SEAL HAS BEEN AFFIXED TO THIS SHEET ONLY FOR PURPOSES OF GEOLOGIC INFORMATION. ALL OTHER INFORMATION SHOULD BE ACQUIRED FROM THE APPROPRIATE SIGNED AND SEALED CIVIL ENGINEERING DRAWINGS.

KFEW
ENGINEERS + SURVEYING
 28231
 Phone #: (210) 978-8444 • Fax #: (210) 978-8441
 TBP# Firm #: 9513 • TBP#S Firm #: 1012200

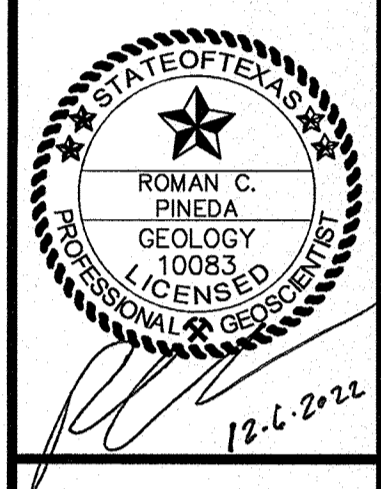

ELSEWHERE GARDEN BAR & KITCHEN (RIDGE EAST)
 SAN ANTONIO, TEXAS
 SITE GEOLOGIC MAP

JOB NO. 1082-01-01
 DATE: NOV 2022
 DRAWN: EU CHECKED: RCP

ATTACHMENT
D

ELSEWHERE GARDEN BAR & KITCHEN (RIDGE EAST)

References

- Arnou, Ted, 1959, Groundwater Geology of Bexar County, Texas: Texas Board of Water Engineers, Bulletin 5911, 62pp., 18 figs.
- Barnes, V.L., 1983, Geologic Atlas of Texas, San Antonio Sheet, Bureau of Economic Geology, The University of Texas at Austin, Texas.
- Collins, E.W., 1993, Geologic Map of the Castle Hills Quadrangle, Texas: University of Texas at Austin, Bureau of Economic Geology, Open-File Map STATEMAP Study Area 5, scale 1:24,000.
- Federal Emergency Management Agency (FEMA), September 28, 2010, Bexar County, Texas and Incorporated areas, Flood Insurance Rate Map (FIRM), Panel 48029C0230G, FEMA, Washington, D.C.
- Maclay, R.W., and Small, T.A., 1976, Progress report on the geology of the Edwards Aquifer, San Antonio Area, Texas and Preliminary Interpretation of Borehole Geophysical and Laboratory Data on Carbonate Rocks: U.S. Geol. Survey open file rept., 76-627, 62 pp., 20 figs.
- Rose, P.R., 1972, Edwards Group, Surface and Subsurface, Central Texas: Bur. Econ. Geol., Rep of Invest. 74, 198 pp.
- Stein, W.G., and Ozuna, G.B., 1995, Geologic Framework and Hydrogeologic Characteristics of the Edwards Aquifer Recharge Zone, Bexar County, Texas: U.S. Geol. Survey, Water – Resources Investigations 95-4030, 8 pp., 2 figs.
- Texas Natural Resource Conservation Commission, 1999, Edwards Aquifer Recharge Zone Map, Castle Hills, NE Quadrangle, TNRCC, San Antonio, Texas.
- United States Department of Agriculture, 1984, Soil Survey of Bexar County, Texas, USDA.
- United States Geologic Survey, 2988, (USGS), Castle Hills, NE Quadrangle, USGS, Denver, Colorado.
- Veni, G., 1988, The Caves of Bexar County, Second Edition, The Texas Memorial Museum, University of Texas, Austin, Texas.
- Veni, George, and Associates, 1994, Geologic Controls in Cave Development and the Distribution of Cave Fauna in the San Antonio, Texas, Region: Report for the Texas Parks and Wildlife Department and U.S. Fish and Wildlife Service, 99 pp.



Engineering
& Design

Protected Species Assessment Report

Elsewhere Garden

Colliers Engineering & Design Project Number: 2201269A

December 6, 2022

Prepared for:

Elsewhere Garden Bar and Kitchen
110 N. Manton Lane
San Antonio, Texas 78213

Prepared by:

Michael Trevino
13501 Katy Freeway Suite 1700 Houston Texas 77079
Main: 281 674 7560
Colliersengineering.com

Table of contents

1.0	Project Information	1
2.0	Introduction	1
3.0	Land Use and Description	1
3.1	Surface Waters, Floodplains, and Wetlands	1
3.2	Topography and Soils	2
4.0	Protected Species Habitat Assessment	2
4.1	Methodology.....	2
4.2	City of San Antonio Protected Habitat	4
4.3	Golden-cheeked Warbler Habitat Requirements.....	4
5.0	Results and Discussion	5
5.1	Habitat Discussion.....	5
6.0	Conclusion and Recommendations	6
7.0	References	7

TABLES

Table 1.	USFWS National Wetlands Inventory Summary	1
Table 2.	NRCS Soil Unit and Description	2
Table 3.	Listed Threatened and Endangered Species potentially occurring within Bexar County, Texas within the Project area	3

APPENDICES

- APPENDIX A – Figures**
- APPENDIX B – Representative Photographs**
- APPENDIX C – USWFS Official Species List**

1.0 PROJECT INFORMATION

Project Name	Elsewhere Garden
County	Bexar
State	Texas
Latitude/Longitude	29.597325 ° N / -98.571931° W
Subject Property Size	+/- 7.29 acres
U.S.G.S. Quadrangle	Castle Hills, Texas

2.0 INTRODUCTION

On behalf of Elsewhere Garden Bar and Kitchen, Colliers Engineering & Design (CED) conducted a protected species assessment within the approximately 7.29 acres tract of the Elsewhere Garden (Project) located within San Antonio, Bexar County, Texas (**Appendix A – Figure 1**).

3.0 LAND USE AND DESCRIPTION

Review of aerial photography and onsite observations show the Project area is surrounded by commercial developments and just north of Highway 1604 (Google Earth Pro 2021). The Project is located within the U.S. Geological Survey (USGS) *Castle Hills, Texas* 7.5-minute Topographic Map Quadrangle. Field observations align with the overall topography depicted in the Topographic Map; the Project area is on a flat plain with the average elevation at 1,000 ft.

3.1 Surface Waters, Floodplains, and Wetlands

A CED biologist reviewed the U.S. Fish and Wildlife Service (USFWS) National Wetlands Inventory (NWI) for potentially mapped features within the Project area (USFWS 2021). **Table 1** and **Figure 2** depicts the NWI data that was reviewed within the Project area.

Table 1. USFWS National Wetlands Inventory Summary

Wetland Type	Cowardin Classification Code*	Count	Acreage within Project Area	% of Project Area
Riverine	R4SBA	1	0.27	3.70%

*USFWS 2019

The Federal Emergency Management Agency (FEMA) National Flood Hazard Layer (FIRM Panel 48029C0230G) depicts approximately 2.19 acres of the Project area within the 100-year floodplain (FEMA 2021; **Figure 2**).

3.2 Topography and Soils

The Project is underlain by the Fredericksburg Group (Ked) as mapped by the USGS Geologic Atlas of Texas. The Fredericksburg Group is underlain by fine to coarse grained, abundant chert, medium gray to grayish brown; fossils are rudistids as reefs and individuals, miliolids, and shell fragments (USGS 2014).

The Natural Resource Conservation Service (NRCS) Web Soil Survey (WSS) depicts one (1) soil unit within the Project area (**Figure 2**). According to the NRCS State Hydric Soils List this soil unit, The Crawford Series, is a silty dark brown clay indurated by limestone bedrock and not considered hydric **Table 2** summarizes the mapped soil units and pertinent information.

Table 2. NRCS Soil Unit and Description

Map Unit Symbol	Soil Description	Hydric - Y/N?	Acreage of Project Area	% of Project Area
Cb	Crawford, stony and Bexar soils, 0 to 5 percent slopes	N	7.29	100%
TOTAL			7.29	100%

4.0 PROTECTED SPECIES HABITAT ASSESSMENT

4.1 Methodology

Federally listed species are protected under federal law by the Endangered Species Act (ESA) of 1973 (16 U.S.C §1531-1544). CED reviewed the USFWS Information, Planning, and Conservation System (IPaC) to identify federally listed threatened and endangered species (TES) which have the potential to occur within the Project.

The resulting USFWS TES list (Consultation Code: 2023-0018997) includes nineteen (19) species listed as federally threatened or endangered potentially occur within the Project area. Of the listed species, none are covered by a determination key within IPaC. Determination keys are logically structured sets of questions that assist a user in determining whether a project qualifies for a predetermined consultation outcome based on an existing programmatic consultation or internal USFWS standing analysis.

Two (2) of the three (3) listed bird species should only be considered for wind energy projects and ten (10) of the insect, arachnid, and crustacean species listed are only listed to occur within the known Karst Zones. This Project occurs within Karst Zone 2, which is an area that has a high probability of containing suitable habitat for listed invertebrate karst species (Veni 2003; **Figure 3**). The karst species habitat was reviewed separately from this assessment by qualified geologists from KFW Engineers & Surveying (KFW). A report detailing the results of the karst habitat evaluation, determination, and recommendations are provided by KFW.

Table 3 includes species listed by the USFWS as threatened or endangered and potentially occurring within the Project area, a description of preferred habitat, and a determination of effect. Discussion of each listed species is provided below.

A field investigation was completed on November 22, 2022, during which time species-specific information was used to evaluate habitat/vegetation communities observed within the survey area against habitat descriptions for federally-listed species.

Table 3. Listed Threatened and Endangered Species potentially occurring within Bexar County, Texas within the Project area

Common Name (<i>Scientific Name</i>)	Federal Status*	Habitat Description	Determination of Effect
Birds			
Golden-cheeked Warbler (<i>Setophaga chrysoparia</i>)	LE	Ashe juniper in mixed stands with various oaks (<i>Quercus spp.</i>). Edges of cedar brakes. Dependent on Ashe juniper (also known as cedar) for long fine bark strips, only available from mature trees, used in nest construction; nests are placed in various trees other than Ashe juniper; only a few mature junipers or nearby cedar brakes can provide the necessary nest material; forage for insects in broad-leaved trees and shrubs; nesting late March-early summer (NatureServe 2022).	Habitat not available; No effect
Amphibians			
San Marcos Salamander (<i>Eurycea nana</i>)	LT	This species inhabits shallow alkaline springs carved out of limestone, with sand and gravel substrate (NatureServe 2022).	Habitat not available; No effect
Texas Blind Salamander (<i>Eurycea rathbuni</i>)	LE	This species inhabits water-filled subterranean caverns (NatureServe 2022).	Habitat not available; No effect
Fish			
Fountain Darter (<i>Etheostoma fonticola</i>)	LE	This species inhabits vegetated springs, pools, and runs of effluent rivers (NatureServe 2022).	No habitat available; No effect
Flowering Plant			
Texas wild-rice (<i>Zizania texana</i>)	LE	This species grows in cool, clear, flowing waters of spring origin with a relatively constant year-round temperature of 20.5 to 23.9°C (NatureServe 2022).	Habitat not available; No effect

*LT – Listed Threatened; LE – Listed Endangered

Additionally, it should be noted that the Monarch butterfly (*Danaus plexippus*) has been listed as a candidate species by the USFWS within the lower 48 states of the US. At this time this species is not afforded any specific legal protection; however, final determination of federal status and applicable regulations surrounding it should be monitored and addressed if listing occurs prior to construction.

An official IPaC species list and consultation letter can be found in **Appendix C**.

4.2 City of San Antonio Protected Habitat

The City of San Antonio (COSA) and Bexar County has designated protected habitat areas for the Golden-cheeked Warbler (GCWA). The COSA defines “Golden-Cheeked Warbler Presumptive Habitat” as any area outside of Loop 1604, north of U.S. Highway 90, and west of Interstate Highway 35. The Project area lies within “GCWA Presumptive Habitat” area as defined by the COSA (**Figure 3**).

4.3 Golden-cheeked Warbler Habitat Requirements

The USFWS uses guidelines set by Campbell (2003) for identifying suitable and non-suitable habitat for the GCWA. Suitable GCWA habitat is defined as vegetation associations where GCWAs are expected to occur. This habitat is defined as woodlands with mature Ashe juniper (*Juniperus ashei*) in a natural mix with oaks (*Quercus spp.*), elms (*Ulmus spp.*), and other hardwoods, in relatively moist (mesic) areas such as steep canyons and slopes, and adjacent uplands. The mature Ashe juniper are trees that are at least 15 ft in height with a trunk diameter of about five inches at diameter at breast height (dbh). These areas generally will have a nearly continuous canopy cover of trees with 50-100% canopy closure and an overall woodland canopy height of 20 ft or more (USFWS 2010).

It should be noted that GCWAs may use a number of other vegetation associations depending on the location, size of the tract, land use, adjacent landscape features, and vegetation structures. These other vegetation associations are typically used by the species when they are located adjacent to or near areas where this species is expected to occur.

The following vegetation associations are not typically considered GCWA habitat and are unlikely to be used by GCWAs unless adjacent to GCWA habitat as described above. These vegetation associations may be considered suitable GCWA foraging habitat if adjacent to occupied habitat as described above:

- Stands of small Ashe juniper, averaging less than 15 ft in height and 5 inches dbh. This includes small juniper that invades open rangelands, previously cleared areas, or old fields. These areas are often dry and relatively flat and lack oaks and other broad-leaved trees and shrubs.
- Pure stands of larger Ashe juniper (greater than 15 ft in height and 5 inches dbh), with few or no oaks or other hardwoods.
- Open park-like woodlands or savannahs (including old junipers) where canopy cover of trees is less than 35%. These areas often have scattered live oaks and other trees.
- Small junipers and other trees coming up along existing fence lines.
- Small junipers (less than 15 ft tall) coming up under larger hardwoods where junipers have been removed in the past 20 years.

5.0 RESULTS AND DISCUSSION

The Project area was dominated by forested and scrub-shrub uplands. The upland habitats observed within the survey area is discussed below and depicted in **Figure 3** and **Appendix B**.

5.1 Habitat Discussion

Vegetation within forested and scrub-shrub uplands were dominated by live oak (*Quercus fusiformis*) within the tree, sapling, and shrub strata. There were isolated stands of Ashe juniper (*Juniperus ashei*) trees and saplings identified within the Project area. However, the Project area appeared to be recently mulched with no continuous canopy cover throughout the Project area.

According to the USFWS GCWA habitat requirements, an open park-like woodland or savannah (including old junipers) where canopy cover of trees is less than 35%, would not be considered suitable habitat for GWCA (**Appendix B**). Therefore, there would be no effect on GCWA as a result of the Project activities (**Figure 4**).

6.0 CONCLUSION AND RECOMMENDATIONS

A qualified biologist from CED conducted a protected species assessment within the 7.29 acres of the Project area located within San Antonio, Bexar County, Texas. Based on the USFWS IPaC official species list, nineteen (19) species are listed as federally threatened or endangered that potentially occur within the Project area. Of the listed species, none are covered by a determination key within IPaC. Two (2) of the three (3) listed bird species should only be considered for wind energy projects and twelve (12) of the insect, arachnid, and crustacean species listed are only listed to occur within the known Karst Zones.

This Project occurs within Karst Zone 2, which is an area that has a high probability of containing suitable habitat for listed invertebrate karst species (Veni 2002; **Figure 3**). A report detailing the results of the karst habitat evaluation, determination of effects, and recommendations are provided by KFW.

The Project occurs within the COSA GCWA presumptive habitat. However, a CED biologist did not identify a dense forest of mature Ashe juniper in a natural mix with oaks (*Quercus spp.*), elms (*Ulmus spp.*), and other hardwoods. The Project area appeared to be recently mulched with no continuous canopy cover throughout the Project area. According to the USFWS GCWA habitat requirements, an open park-like woodland or savannah (including old junipers) where canopy cover of trees is less than 35%, would not be considered suitable habitat for GWCA (**Figure 4**). Therefore, it is CED's opinion that there would be "no effect" on the GCWA as a result of the Project activities.

CED observed no suitable habitat available for any other federally listed threatened and endangered species that potentially may occur within the Project area. It is CED opinion that there would be "no effect" on these listed species as result of the Project activities. A "no effect" determination does not require coordination with the USFWS nor consultation under Section 7 of the ESA.

7.0 REFERENCES

Campbell, L.

2003 Endangered and threatened animals of Texas: Their life history and management. Endangered Resource Branch, Texas Parks and Wildlife Department, Austin.

Federal Emergency Management Agency (FEMA)

2021 FEMA Map Service Center. <https://www.fema.gov/national-flood-hazard-layer-nfhl>. Accessed December 2022.

Google Earth Pro

2021 Google earth V 7.3.4.8248. San Antonio, Texas. <http://www.earth.google.com>. Accessed December 2022.

NatureServe Explorer (NatureServe)

2022 <http://explorer.natureserve.org/>. Accessed December 2022.

U.S. Fish and Wildlife Service (USFWS)

2010 USFWS Section 10(a)(1)(A) Scientific Permit Requirements for Conducting Presence/Absence Surveys and Habitat Assessments for Endangered Golden-cheeked Warblers. USFWS Ecological Services office, Austin, Texas.

2021 National Wetland Inventory Database. Available online: <https://www.fws.gov/wetlands/>. Accessed December 2022.

U.S. Geological Survey (USGS)

2014 Texas Water Science Center. Geologic Database of Texas. Accessed December 2022.

Veni, George & Associates.

2002 Revisiting the Karst Map of the United States. *Journal of Cave and Karst Studies* 64(1): 45-50.

Appendix

Appendix A | Figures

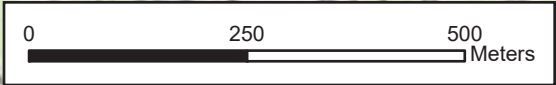
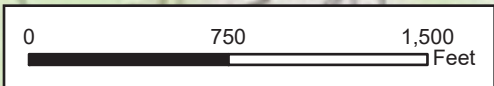

Source: USGS 24k Quadrangles: Bexar, TX

Prepared For:
 Elsewhere Garden Bar and Kitchen
 110 N. Manton Lane
 San Antonio, TX 78213

Prepared By:
 Houston Office
 13501 Katy Fwy #1700
 77079
 T: 281.674.7560
 www.colliersengineering.com



Engineering & Design

Vicinity Map

Elsewhere Garden

Bexar County, Texas

Date:
 11/30/2022

Drawn By:
 MT

Figure 1

Project Area

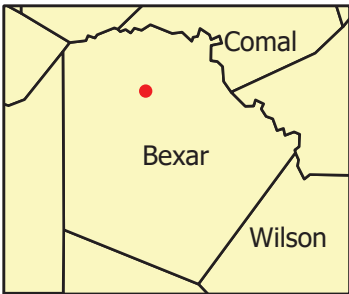

Prepared For:
 Elsewhere Garden Bar and Kitchen
 110 N. Manton Lane
 San Antonio, Texas 78213

Prepared By:
 Houston Office
 13501 Katy Fwy #1700
 77079
 T: 281.674.7560
 www.colliersengineering.com



Engineering & Design

Background Data Map

Elsewhere Garden

Bexar County, Texas

Date:

11/30/2022

Drawn By:

MT

Figure 2

- ▭ Project Area
- ▭ Flowline (NHD)
- ▭ Soils (NRCS)
- ▭ Wetlands (NWI)
- ▭ Riverine
- ▭ AE

100-year Floodplain

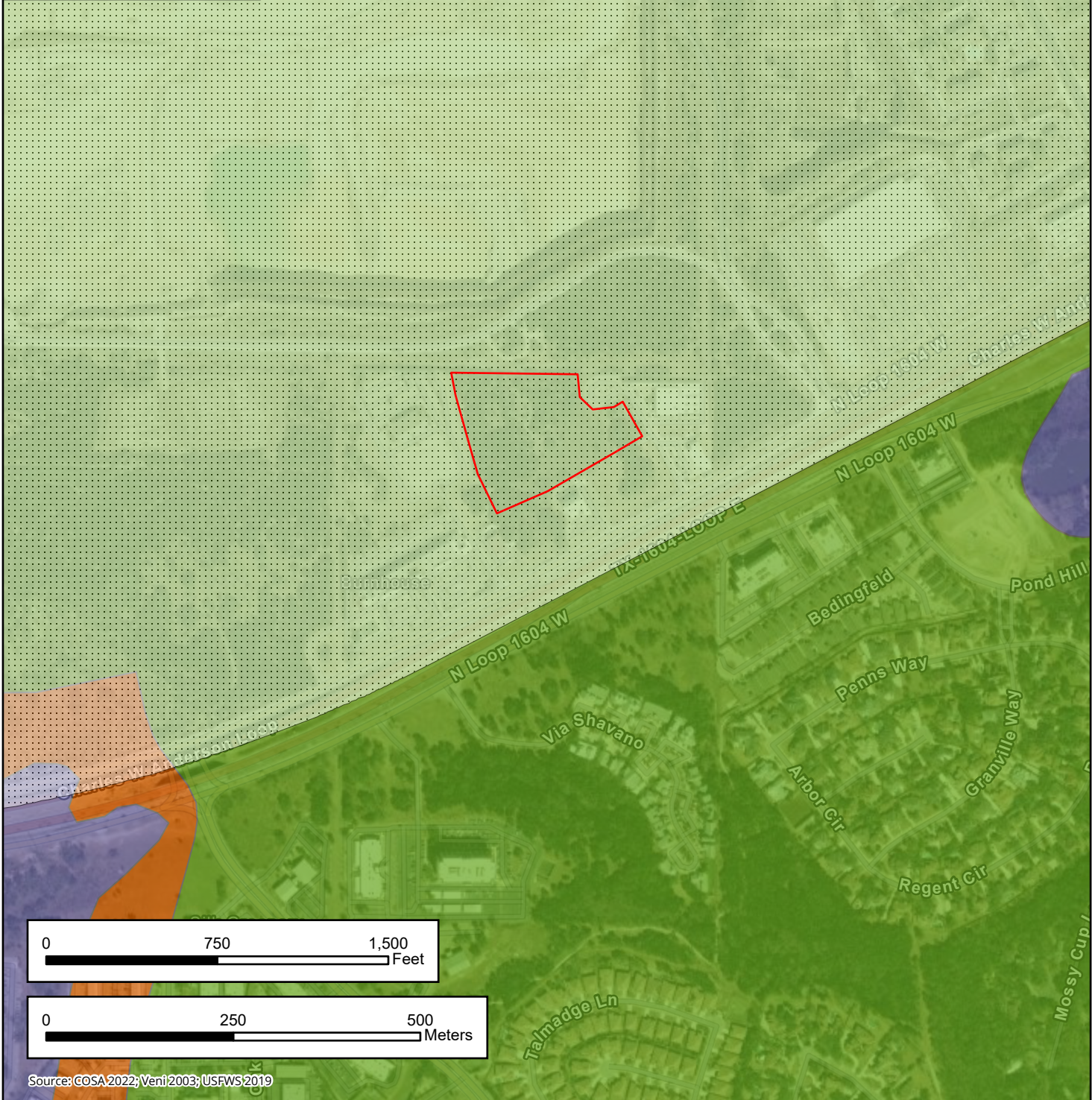
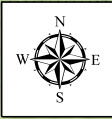
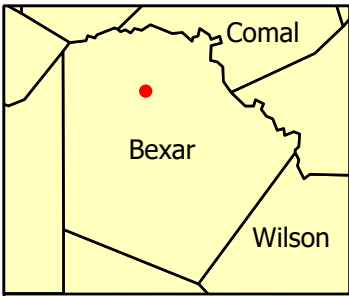

Prepared For:
 Elsewhere Garden Bar and Kitchen
 110 N. Manton Lane
 San Antonio, TX 78213

Prepared By:
 Houston Office
 13501 Katy Fwy #1700
 77079
 T: 281.674.7560
 www.colliersengineering.com



Engineering & Design

Protected Species Background Map
Elsewhere Garden
 Bexar County, Texas

Date: 12/6/2022

Drawn By: AR

Figure 3

- Project Area
- COSA Presumptive GCWA Habitat
- Karst Zone 2
- Karst Zone 3
- Karst Zone 5

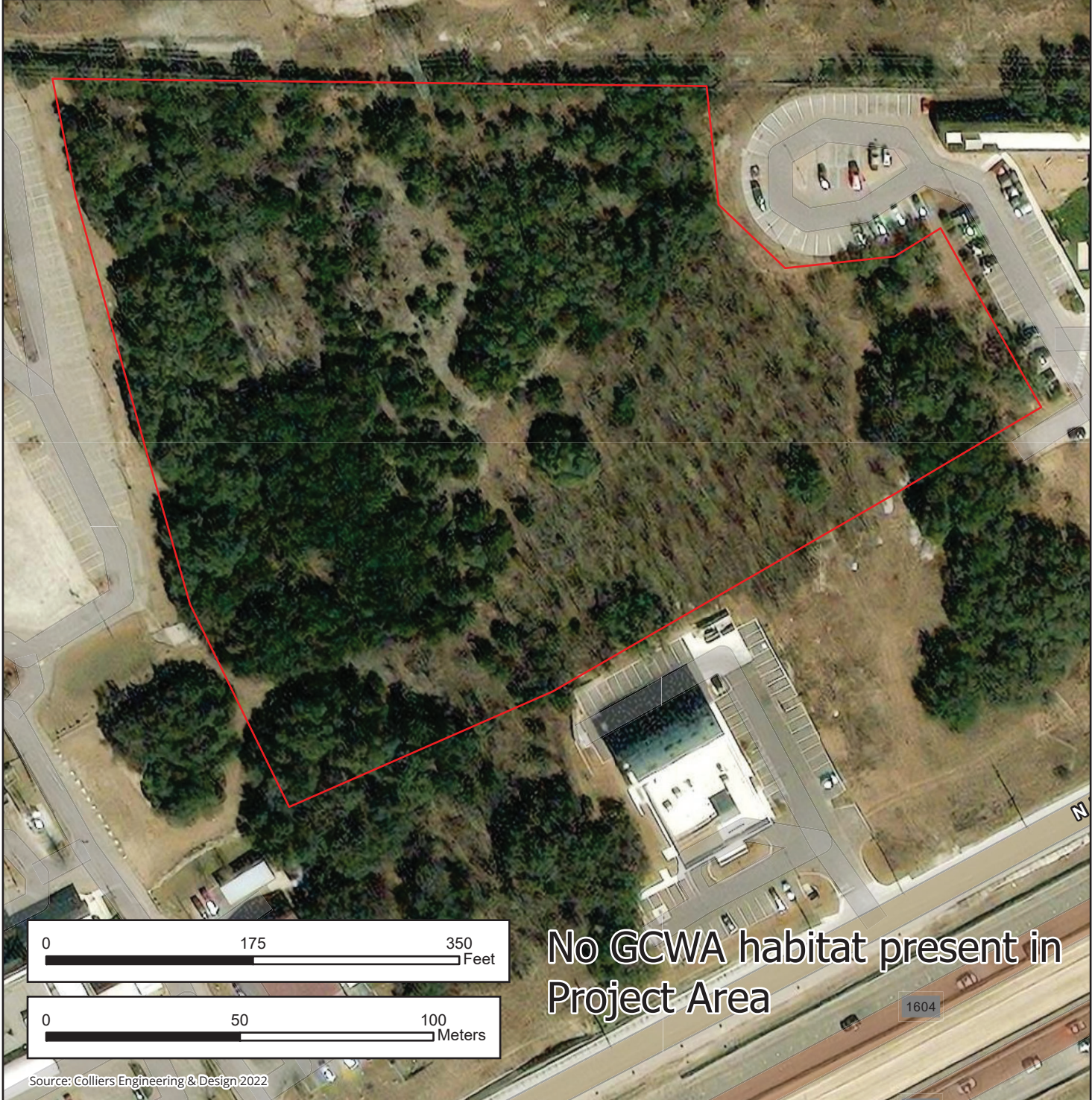
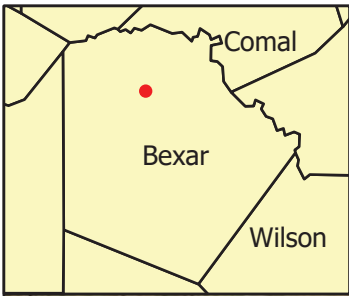

No GCWA habitat present in Project Area

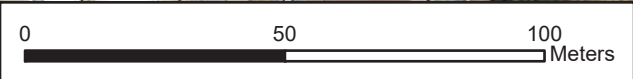

Source: Colliers Engineering & Design 2022

Prepared For:
 Elsewhere Garden Bar and Kitchen
 110 N. Manton Lane
 San Antonio, TX 78213

Prepared By:
 Houston Office
 13501 Katy Fwy #1700
 77079
 T: 281.674.7560
 www.colliersengineering.com

Protected Species Assessment Map
Elsewhere Garden
 Bexar County, Texas

Date:	11/30/2022	Drawn By:	MT
-------	------------	-----------	----

Figure 4
 Project Area



Appendix B | Representative Photographs



Photo 1: View of the representative tree and shrub species at the southwestern corner of the Project area.



Photo 2: View of the representative tree and shrub species at the northwestern corner of the Project area.



Photo 3: View of the representative tree and shrub species present within the central portion of the Project area.



Photo 4: View of the representative tree and shrub species at the northeastern corner of the Project area.



Photo 5: View of the representative tree and shrub species at the southeastern corner of the Project area.

Appendix C | USFWS Official Species List



United States Department of the Interior



FISH AND WILDLIFE SERVICE
Austin Ecological Services Field Office
10711 Burnet Road, Suite 200
Austin, TX 78758-4460
Phone: (512) 490-0057 Fax: (512) 490-0974

In Reply Refer To:
Project Code: 2023-0018997
Project Name: Elsewhere Garden

November 28, 2022

Subject: List of threatened and endangered species that may occur in your proposed project location or may be affected by your proposed project

To Whom It May Concern:

The enclosed species list identifies threatened, endangered, proposed and candidate species, as well as proposed and final designated critical habitat, that may occur within the boundary of your proposed project and/or may be affected by your proposed project. The species list fulfills the requirements of the U.S. Fish and Wildlife Service (Service) under section 7(c) of the Endangered Species Act (Act) of 1973, as amended (16 U.S.C. 1531 *et seq.*).

New information based on updated surveys, changes in the abundance and distribution of species, changed habitat conditions, or other factors could change this list. Please feel free to contact us if you need more current information or assistance regarding the potential impacts to federally proposed, listed, and candidate species and federally designated and proposed critical habitat. Please note that under 50 CFR 402.12(e) of the regulations implementing section 7 of the Act, the accuracy of this species list should be verified after 90 days. This verification can be completed formally or informally as desired. The Service recommends that verification be completed by visiting the ECOS-IPaC website at regular intervals during project planning and implementation for updates to species lists and information. An updated list may be requested through the ECOS-IPaC system by completing the same process used to receive the enclosed list.

The purpose of the Act is to provide a means whereby threatened and endangered species and the ecosystems upon which they depend may be conserved. Under sections 7(a)(1) and 7(a)(2) of the Act and its implementing regulations (50 CFR 402 *et seq.*), Federal agencies are required to utilize their authorities to carry out programs for the conservation of threatened and endangered species and to determine whether projects may affect threatened and endangered species and/or designated critical habitat.

A Biological Assessment is required for construction projects (or other undertakings having similar physical impacts) that are major Federal actions significantly affecting the quality of the human environment as defined in the National Environmental Policy Act (42 U.S.C. 4332(2) (c)). For projects other than major construction activities, the Service suggests that a biological

evaluation similar to a Biological Assessment be prepared to determine whether the project may affect listed or proposed species and/or designated or proposed critical habitat. Recommended contents of a Biological Assessment are described at 50 CFR 402.12.

If a Federal agency determines, based on the Biological Assessment or biological evaluation, that listed species and/or designated critical habitat may be affected by the proposed project, the agency is required to consult with the Service pursuant to 50 CFR 402. In addition, the Service recommends that candidate species, proposed species and proposed critical habitat be addressed within the consultation. More information on the regulations and procedures for section 7 consultation, including the role of permit or license applicants, can be found in the "Endangered Species Consultation Handbook" at:

<http://www.fws.gov/endangered/esa-library/pdf/TOC-GLOS.PDF>

Migratory Birds: In addition to responsibilities to protect threatened and endangered species under the Endangered Species Act (ESA), there are additional responsibilities under the Migratory Bird Treaty Act (MBTA) and the Bald and Golden Eagle Protection Act (BGEPA) to protect native birds from project-related impacts. Any activity, intentional or unintentional, resulting in take of migratory birds, including eagles, is prohibited unless otherwise permitted by the U.S. Fish and Wildlife Service (50 C.F.R. Sec. 10.12 and 16 U.S.C. Sec. 668(a)). For more information regarding these Acts see <https://www.fws.gov/birds/policies-and-regulations.php>.

The MBTA has no provision for allowing take of migratory birds that may be unintentionally killed or injured by otherwise lawful activities. It is the responsibility of the project proponent to comply with these Acts by identifying potential impacts to migratory birds and eagles within applicable NEPA documents (when there is a federal nexus) or a Bird/Eagle Conservation Plan (when there is no federal nexus). Proponents should implement conservation measures to avoid or minimize the production of project-related stressors or minimize the exposure of birds and their resources to the project-related stressors. For more information on avian stressors and recommended conservation measures see <https://www.fws.gov/birds/bird-enthusiasts/threats-to-birds.php>.

In addition to MBTA and BGEPA, Executive Order 13186: *Responsibilities of Federal Agencies to Protect Migratory Birds*, obligates all Federal agencies that engage in or authorize activities that might affect migratory birds, to minimize those effects and encourage conservation measures that will improve bird populations. Executive Order 13186 provides for the protection of both migratory birds and migratory bird habitat. For information regarding the implementation of Executive Order 13186, please visit <https://www.fws.gov/birds/policies-and-regulations/executive-orders/e0-13186.php>.

We appreciate your concern for threatened and endangered species. The Service encourages Federal agencies to include conservation of threatened and endangered species into their project planning to further the purposes of the Act. Please include the Consultation Code in the header of this letter with any request for consultation or correspondence about your project that you submit to our office.

Attachment(s):

- Official Species List

Official Species List

This list is provided pursuant to Section 7 of the Endangered Species Act, and fulfills the requirement for Federal agencies to "request of the Secretary of the Interior information whether any species which is listed or proposed to be listed may be present in the area of a proposed action".

This species list is provided by:

Austin Ecological Services Field Office

10711 Burnet Road, Suite 200

Austin, TX 78758-4460

(512) 490-0057

Project Summary

Project Code: 2023-0018997

Project Name: Elsewhere Garden

Project Type: Commercial Development

Project Description: Proposed commercial development within an approximate 8-acre tract in San Antonio, Bexar County, Texas.

Project Location:

Approximate location of the project can be viewed in Google Maps: <https://www.google.com/maps/@29.59751215,-98.57232919984763,14z>



Counties: Bexar County, Texas

Endangered Species Act Species

There is a total of 19 threatened, endangered, or candidate species on this species list.

Species on this list should be considered in an effects analysis for your project and could include species that exist in another geographic area. For example, certain fish may appear on the species list because a project could affect downstream species. Note that 2 of these species should be considered only under certain conditions.

IPaC does not display listed species or critical habitats under the sole jurisdiction of NOAA Fisheries¹, as USFWS does not have the authority to speak on behalf of NOAA and the Department of Commerce.

See the "Critical habitats" section below for those critical habitats that lie wholly or partially within your project area under this office's jurisdiction. Please contact the designated FWS office if you have questions.

-
1. [NOAA Fisheries](#), also known as the National Marine Fisheries Service (NMFS), is an office of the National Oceanic and Atmospheric Administration within the Department of Commerce.

Birds

NAME	STATUS
Golden-cheeked Warbler <i>Setophaga chrysoparia</i> No critical habitat has been designated for this species. Species profile: https://ecos.fws.gov/ecp/species/33	Endangered
Piping Plover <i>Charadrius melodus</i> Population: [Atlantic Coast and Northern Great Plains populations] - Wherever found, except those areas where listed as endangered. There is final critical habitat for this species. Your location does not overlap the critical habitat. This species only needs to be considered under the following conditions: <ul style="list-style-type: none"> ▪ Wind Energy Projects Species profile: https://ecos.fws.gov/ecp/species/6039	Threatened
Red Knot <i>Calidris canutus rufa</i> There is proposed critical habitat for this species. This species only needs to be considered under the following conditions: <ul style="list-style-type: none"> ▪ Wind Energy Projects Species profile: https://ecos.fws.gov/ecp/species/1864	Threatened

Amphibians

NAME	STATUS
San Marcos Salamander <i>Eurycea nana</i> There is final critical habitat for this species. Your location does not overlap the critical habitat. Species profile: https://ecos.fws.gov/ecp/species/6374	Threatened
Texas Blind Salamander <i>Eurycea rathbuni</i> No critical habitat has been designated for this species. Species profile: https://ecos.fws.gov/ecp/species/5130	Endangered

Fishes

NAME	STATUS
Fountain Darter <i>Etheostoma fonticola</i> There is final critical habitat for this species. Your location does not overlap the critical habitat. Species profile: https://ecos.fws.gov/ecp/species/5858	Endangered

Insects

NAME	STATUS
[no Common Name] Beetle <i>Rhadine exilis</i> There is final critical habitat for this species. Your location does not overlap the critical habitat. Species profile: https://ecos.fws.gov/ecp/species/6942	Endangered
[no Common Name] Beetle <i>Rhadine infernalis</i> There is final critical habitat for this species. Your location does not overlap the critical habitat. Species profile: https://ecos.fws.gov/ecp/species/3804	Endangered
Comal Springs Dryopid Beetle <i>Stygoparnus comalensis</i> There is final critical habitat for this species. Your location does not overlap the critical habitat. Species profile: https://ecos.fws.gov/ecp/species/7175	Endangered
Comal Springs Riffle Beetle <i>Heterelmis comalensis</i> There is final critical habitat for this species. Your location does not overlap the critical habitat. Species profile: https://ecos.fws.gov/ecp/species/3403	Endangered
Helotes Mold Beetle <i>Batrisodes venyivi</i> There is final critical habitat for this species. Your location does not overlap the critical habitat. Species profile: https://ecos.fws.gov/ecp/species/1149	Endangered
Monarch Butterfly <i>Danaus plexippus</i> No critical habitat has been designated for this species. Species profile: https://ecos.fws.gov/ecp/species/9743	Candidate

Arachnids

NAME	STATUS
Cokendolpher Cave Harvestman <i>Texella cokendolpheri</i> There is final critical habitat for this species. Your location does not overlap the critical habitat. Species profile: https://ecos.fws.gov/ecp/species/676	Endangered
Government Canyon Bat Cave Meshweaver <i>Cicurina vespera</i> There is final critical habitat for this species. Your location does not overlap the critical habitat. Species profile: https://ecos.fws.gov/ecp/species/7037	Endangered
Government Canyon Bat Cave Spider <i>Tayshaneta microps</i> There is final critical habitat for this species. Your location does not overlap the critical habitat. Species profile: https://ecos.fws.gov/ecp/species/553	Endangered
Madla Cave Meshweaver <i>Cicurina madla</i> There is final critical habitat for this species. Your location does not overlap the critical habitat. Species profile: https://ecos.fws.gov/ecp/species/2467	Endangered
Robber Baron Cave Meshweaver <i>Cicurina baronia</i> There is final critical habitat for this species. Your location does not overlap the critical habitat. Species profile: https://ecos.fws.gov/ecp/species/2361	Endangered

Crustaceans

NAME	STATUS
Peck's Cave Amphipod <i>Stygobromus (=Stygonectes) pecki</i> There is final critical habitat for this species. Your location does not overlap the critical habitat. Species profile: https://ecos.fws.gov/ecp/species/8575	Endangered

Flowering Plants

NAME	STATUS
Texas Wild-rice <i>Zizania texana</i> There is final critical habitat for this species. Your location does not overlap the critical habitat. Species profile: https://ecos.fws.gov/ecp/species/805	Endangered

Critical habitats

THERE ARE NO CRITICAL HABITATS WITHIN YOUR PROJECT AREA UNDER THIS OFFICE'S JURISDICTION.

IPaC User Contact Information

Agency: Collier's Engineering & Design
Name: Michael Trevino
Address: 3421 Paesanos Pkwy #200
City: San Antonio
State: TX
Zip: 78231
Email: michael.trevino@collierseng.com
Phone: 7262280127



Engineering & Design

Colliers Engineering & Design is a trusted provider of multi-discipline engineering, design and consulting services providing customized solutions for public and private clients through a network of offices nationwide.

For a full listing of our office locations, please visit colliersengineering.com

1 877 627 3772



*Civil/Site • Traffic/Transportation • Governmental • Survey/Geospatial
Infrastructure • Geotechnical/Environmental • Telecommunications • Utilities/Energy*

WATER POLLUTION ABATEMENT PLAN APPLICATION

Water Pollution Abatement Plan Application

Texas Commission on Environmental Quality

for Regulated Activities on the Edwards Aquifer Recharge Zone and Relating to 30 TAC §213.5(b), Effective June 1, 1999

To ensure that the application is administratively complete, confirm that all fields in the form are complete, verify that all requested information is provided, consistently reference the same site and contact person in all forms in the application, and ensure forms are signed by the appropriate party.

Note: Including all the information requested in the form and attachments contributes to more streamlined technical reviews.

Signature

To the best of my knowledge, the responses to this form accurately reflect all information requested concerning the proposed regulated activities and methods to protect the Edwards Aquifer. This **Water Pollution Abatement Plan Application Form** is hereby submitted for TCEQ review and Executive Director approval. The form was prepared by:

Print Name of Customer/Agent: Frank D. Corey, PE

Date: 06/22/2023

Signature of Customer/Agent:



Regulated Entity Name: Elsewhere Garden Bar & Kitchen

Regulated Entity Information

1. The type of project is:

- Residential: Number of Lots: _____
- Residential: Number of Living Unit Equivalents: _____
- Commercial
- Industrial
- Other: _____

2. Total site acreage (size of property): 4.32

3. Estimated projected population: N/A

4. The amount and type of impervious cover expected after construction are shown below:

Table 1 - Impervious Cover Table

Impervious Cover of Proposed Project	Sq. Ft.	Sq. Ft./Acre	Acres
Structures/Rooftops	5,944.52	÷ 43,560 =	0.14
Parking	48,400.83	÷ 43,560 =	1.11
Other paved surfaces	16,671.44	÷ 43,560 =	0.38
Total Impervious Cover	71,016.79	÷ 43,560 =	1.63

Total Impervious Cover 1.62 ÷ Total Acreage 4.32 X 100 = 37.47% Impervious Cover

5. **Attachment A - Factors Affecting Surface Water Quality.** A detailed description of all factors that could affect surface water and groundwater quality that addresses ultimate land use is attached.
6. Only inert materials as defined by 30 TAC §330.2 will be used as fill material.

For Road Projects Only

Complete questions 7 - 12 if this application is exclusively for a road project.

7. Type of project:

- TXDOT road project.
- County road or roads built to county specifications.
- City thoroughfare or roads to be dedicated to a municipality.
- Street or road providing access to private driveways.

8. Type of pavement or road surface to be used:

- Concrete
- Asphaltic concrete pavement
- Other: _____

9. Length of Right of Way (R.O.W.): _____ feet.

Width of R.O.W.: _____ feet.

L x W = _____ Ft² ÷ 43,560 Ft²/Acre = _____ acres.

10. Length of pavement area: _____ feet.

Width of pavement area: _____ feet.

L x W = _____ Ft² ÷ 43,560 Ft²/Acre = _____ acres.

Pavement area _____ acres ÷ R.O.W. area _____ acres x 100 = _____% impervious cover.

11. A rest stop will be included in this project.

A rest stop will not be included in this project.

12. Maintenance and repair of existing roadways that do not require approval from the TCEQ Executive Director. Modifications to existing roadways such as widening roads/adding shoulders totaling more than one-half (1/2) the width of one (1) existing lane require prior approval from the TCEQ.

Stormwater to be generated by the Proposed Project

13. **Attachment B - Volume and Character of Stormwater.** A detailed description of the volume (quantity) and character (quality) of the stormwater runoff which is expected to occur from the proposed project is attached. The estimates of stormwater runoff quality and quantity are based on the area and type of impervious cover. Include the runoff coefficient of the site for both pre-construction and post-construction conditions.

Wastewater to be generated by the Proposed Project

14. The character and volume of wastewater is shown below:

<u>100%</u> Domestic	<u>4,000</u> Gallons/day
<u> </u> % Industrial	<u> </u> Gallons/day
<u> </u> % Commingled	<u> </u> Gallons/day
TOTAL gallons/day <u>4,000</u>	

15. Wastewater will be disposed of by:

On-Site Sewage Facility (OSSF/Septic Tank):

Attachment C - Suitability Letter from Authorized Agent. An on-site sewage facility will be used to treat and dispose of the wastewater from this site. The appropriate licensing authority's (authorized agent) written approval is attached. It states that the land is suitable for the use of private sewage facilities and will meet or exceed the requirements for on-site sewage facilities as specified under 30 TAC Chapter 285 relating to On-site Sewage Facilities.

Each lot in this project/development is at least one (1) acre (43,560 square feet) in size. The system will be designed by a licensed professional engineer or registered sanitarian and installed by a licensed installer in compliance with 30 TAC Chapter 285.

Sewage Collection System (Sewer Lines):

Private service laterals from the wastewater generating facilities will be connected to an existing SCS.

Private service laterals from the wastewater generating facilities will be connected to a proposed SCS.

The SCS was previously submitted on _____.

The SCS was submitted with this application.

The SCS will be submitted at a later date. The owner is aware that the SCS may not be installed prior to Executive Director approval.

The sewage collection system will convey the wastewater to the Dos Rios Wastewater (name) Treatment Plant. The treatment facility is:

Existing.

Proposed.

16. All private service laterals will be inspected as required in 30 TAC §213.5.

Site Plan Requirements

Items 17 – 28 must be included on the Site Plan.

17. The Site Plan must have a minimum scale of 1" = 400'.

Site Plan Scale: 1" = 30'.

18. 100-year floodplain boundaries:

Some part(s) of the project site is located within the 100-year floodplain. The floodplain is shown and labeled.

No part of the project site is located within the 100-year floodplain.

The 100-year floodplain boundaries are based on the following specific (including date of material) sources(s): FEMA Map Number 48029C0230G

19. The layout of the development is shown with existing and finished contours at appropriate, but not greater than ten-foot contour intervals. Lots, recreation centers, buildings, roads, open space, etc. are shown on the plan.

The layout of the development is shown with existing contours at appropriate, but not greater than ten-foot intervals. Finished topographic contours will not differ from the existing topographic configuration and are not shown. Lots, recreation centers, buildings, roads, open space, etc. are shown on the site plan.

20. All known wells (oil, water, unplugged, capped and/or abandoned, test holes, etc.):

There are _____ (#) wells present on the project site and the locations are shown and labeled. (Check all of the following that apply)

The wells are not in use and have been properly abandoned.

The wells are not in use and will be properly abandoned.

The wells are in use and comply with 16 TAC §76.

There are no wells or test holes of any kind known to exist on the project site.

21. Geologic or manmade features which are on the site:

All sensitive geologic or manmade features identified in the Geologic Assessment are shown and labeled.

No sensitive geologic or manmade features were identified in the Geologic Assessment.

Attachment D - Exception to the Required Geologic Assessment. A request and justification for an exception to a portion of the Geologic Assessment is attached.

- 22. The drainage patterns and approximate slopes anticipated after major grading activities.
- 23. Areas of soil disturbance and areas which will not be disturbed.
- 24. Locations of major structural and nonstructural controls. These are the temporary and permanent best management practices.
- 25. Locations where soil stabilization practices are expected to occur.
- 26. Surface waters (including wetlands).
 - N/A
- 27. Locations where stormwater discharges to surface water or sensitive features are to occur.
 - There will be no discharges to surface water or sensitive features.
- 28. Legal boundaries of the site are shown.

Administrative Information

- 29. Submit one (1) original and one (1) copy of the application, plus additional copies as needed for each affected incorporated city, groundwater conservation district, and county in which the project will be located. The TCEQ will distribute the additional copies to these jurisdictions. The copies must be submitted to the appropriate regional office.
- 30. Any modification of this WPAP will require Executive Director approval, prior to construction, and may require submission of a revised application, with appropriate fees.

Edwards Aquifer Group

Attachment A

Water Pollution Abatement Plan
Application Section

Factors Affecting Water Quality

Materials that are anticipated to be used on site that could be a potential source of contamination include the following:

During Construction:

1. Concrete and Masonry Materials.
2. Wood, plastic, metal Materials.
3. Tar and hydrocarbons from paving operations.
4. Oil, grease, fuel, and hydraulic fluid from construction equipment and vehicle drippings.
5. Fertilizers, herbicides, and pesticides.
6. Cleaning solutions and detergents.
7. Miscellaneous construction trash and debris.
8. Soil erosion and sedimentation due to construction activity.

Ultimate Use:

1. Pollutants generated from vehicles utilizing the site.
2. Fertilizers, herbicides, and pesticides used to maintain landscaping.
3. Miscellaneous trash and debris generated from the public.

(This is not intended to be an all-inclusive list)

All practical management practices will be used to reduce the risk of spills and other exposure of any contaminant to surface or groundwater.

VOLUME AND CHARACTER OF STORMWATER

The existing storm water runoff for the subject site consists of three (4) drainage areas encompassing the entire project area. The total existing drainage area is 4.32 acres of undeveloped land with natural vegetation within the site. A runoff coefficient of 0.53 was used. Calculations and results are provided on the Existing Condition Drainage Map located at the end of this report (**Exhibit 3A**).

The proposed development will have a total impervious cover of 1.622 acres and will consist of construction of an outdoor seating area with bar, kitchen, stage, and event pavilion. Parking areas, access drives, storm drain, and utilities will also be constructed. For proposed conditions, the project area has been divided into four (4) drainage areas. Calculations and results for the proposed development are provided on the Proposed Condition Drainage Map located at the end of this report (**Exhibit 3B**).

Edwards Aquifer Group
Water Pollution Abatement Plan
Application Section

Attachment C

SUITABILITY LETTER FROM AUTHORIZED AGENT

An on-site sewage facility will not be used to treat and dispose of the wastewater. Therefore, the appropriate licensing authority's (Authorized agent) written approval is not required.

EXCEPTION TO THE REQUIRED GEOLOGIC ASSESSMENT

A Geologic Assessment was conducted for this project, and has been included in Section 2 of this report. Therefore, an exception to the Geologic Assessment requirement will not be requested.

TEMPORARY STORMWATER SECTION

Temporary Stormwater Section

Texas Commission on Environmental Quality

for Regulated Activities on the Edwards Aquifer Recharge Zone and Relating to 30 TAC §213.5(b)(4)(A), (B), (D)(I) and (G); Effective June 1, 1999

To ensure that the application is administratively complete, confirm that all fields in the form are complete, verify that all requested information is provided, consistently reference the same site and contact person in all forms in the application, and ensure forms are signed by the appropriate party.

Note: Including all the information requested in the form and attachments contributes to more streamlined technical reviews.

Signature

To the best of my knowledge, the responses to this form accurately reflect all information requested concerning the proposed regulated activities and methods to protect the Edwards Aquifer. This **Temporary Stormwater Section** is hereby submitted for TCEQ review and executive director approval. The application was prepared by:

Print Name of Customer/Agent: Frank D. Corey, PE

Date: 06/22/23

Signature of Customer/Agent:



Regulated Entity Name: Elsewhere Garden Bar & Kitchen

Project Information

Potential Sources of Contamination

Examples: Fuel storage and use, chemical storage and use, use of asphaltic products, construction vehicles tracking onto public roads, and existing solid waste.

1. Fuels for construction equipment and hazardous substances which will be used during construction:

The following fuels and/or hazardous substances will be stored on the site: _____

These fuels and/or hazardous substances will be stored in:

- Aboveground storage tanks with a cumulative storage capacity of less than 250 gallons will be stored on the site for less than one (1) year.

- Aboveground storage tanks with a cumulative storage capacity between 250 gallons and 499 gallons will be stored on the site for less than one (1) year.
- Aboveground storage tanks with a cumulative storage capacity of 500 gallons or more will be stored on the site. An Aboveground Storage Tank Facility Plan application must be submitted to the appropriate regional office of the TCEQ prior to moving the tanks onto the project.
- Fuels and hazardous substances will not be stored on the site.
- 2. **Attachment A - Spill Response Actions.** A site specific description of the measures to be taken to contain any spill of hydrocarbons or hazardous substances is attached.
- 3. Temporary aboveground storage tank systems of 250 gallons or more cumulative storage capacity must be located a minimum horizontal distance of 150 feet from any domestic, industrial, irrigation, or public water supply well, or other sensitive feature.
- 4. **Attachment B - Potential Sources of Contamination.** A description of any activities or processes which may be a potential source of contamination affecting surface water quality is attached.

Sequence of Construction

- 5. **Attachment C - Sequence of Major Activities.** A description of the sequence of major activities which will disturb soils for major portions of the site (grubbing, excavation, grading, utilities, and infrastructure installation) is attached.
 - For each activity described, an estimate (in acres) of the total area of the site to be disturbed by each activity is given.
 - For each activity described, include a description of appropriate temporary control measures and the general timing (or sequence) during the construction process that the measures will be implemented.
- 6. Name the receiving water(s) at or near the site which will be disturbed or which will receive discharges from disturbed areas of the project: Upper San Antonio Watershed

Temporary Best Management Practices (TBMPs)

Erosion control examples: tree protection, interceptor swales, level spreaders, outlet stabilization, blankets or matting, mulch, and sod. Sediment control examples: stabilized construction exit, silt fence, filter dikes, rock berms, buffer strips, sediment traps, and sediment basins. Please refer to the Technical Guidance Manual for guidelines and specifications. All structural BMPs must be shown on the site plan.

- 7. **Attachment D – Temporary Best Management Practices and Measures.** TBMPs and measures will prevent pollution of surface water, groundwater, and stormwater. The construction-phase BMPs for erosion and sediment controls have been designed to retain sediment on site to the extent practicable. The following information is attached:

- A description of how BMPs and measures will prevent pollution of surface water, groundwater or stormwater that originates upgradient from the site and flows across the site.
 - A description of how BMPs and measures will prevent pollution of surface water or groundwater that originates on-site or flows off site, including pollution caused by contaminated stormwater runoff from the site.
 - A description of how BMPs and measures will prevent pollutants from entering surface streams, sensitive features, or the aquifer.
 - A description of how, to the maximum extent practicable, BMPs and measures will maintain flow to naturally-occurring sensitive features identified in either the geologic assessment, TCEQ inspections, or during excavation, blasting, or construction.
8. The temporary sealing of a naturally-occurring sensitive feature which accepts recharge to the Edwards Aquifer as a temporary pollution abatement measure during active construction should be avoided.
- Attachment E - Request to Temporarily Seal a Feature.** A request to temporarily seal a feature is attached. The request includes justification as to why no reasonable and practicable alternative exists for each feature.
 - There will be no temporary sealing of naturally-occurring sensitive features on the site.
9. **Attachment F - Structural Practices.** A description of the structural practices that will be used to divert flows away from exposed soils, to store flows, or to otherwise limit runoff discharge of pollutants from exposed areas of the site is attached. Placement of structural practices in floodplains has been avoided.
10. **Attachment G - Drainage Area Map.** A drainage area map supporting the following requirements is attached:
- For areas that will have more than 10 acres within a common drainage area disturbed at one time, a sediment basin will be provided.
 - For areas that will have more than 10 acres within a common drainage area disturbed at one time, a smaller sediment basin and/or sediment trap(s) will be used.
 - For areas that will have more than 10 acres within a common drainage area disturbed at one time, a sediment basin or other equivalent controls are not attainable, but other TBMPs and measures will be used in combination to protect down slope and side slope boundaries of the construction area.
 - There are no areas greater than 10 acres within a common drainage area that will be disturbed at one time. A smaller sediment basin and/or sediment trap(s) will be used in combination with other erosion and sediment controls within each disturbed drainage area.

- There are no areas greater than 10 acres within a common drainage area that will be disturbed at one time. Erosion and sediment controls other than sediment basins or sediment traps within each disturbed drainage area will be used.
11. **Attachment H - Temporary Sediment Pond(s) Plans and Calculations.** Temporary sediment pond or basin construction plans and design calculations for a proposed temporary BMP or measure have been prepared by or under the direct supervision of a Texas Licensed Professional Engineer. All construction plans and design information must be signed, sealed, and dated by the Texas Licensed Professional Engineer. Construction plans for the proposed temporary BMPs and measures are attached.
- N/A
12. **Attachment I - Inspection and Maintenance for BMPs.** A plan for the inspection of each temporary BMP(s) and measure(s) and for their timely maintenance, repairs, and, if necessary, retrofit is attached. A description of the documentation procedures, recordkeeping practices, and inspection frequency are included in the plan and are specific to the site and/or BMP.
13. All control measures must be properly selected, installed, and maintained in accordance with the manufacturer's specifications and good engineering practices. If periodic inspections by the applicant or the executive director, or other information indicate a control has been used inappropriately, or incorrectly, the applicant must replace or modify the control for site situations.
14. If sediment escapes the construction site, off-site accumulations of sediment must be removed at a frequency sufficient to minimize offsite impacts to water quality (e.g., fugitive sediment in street being washed into surface streams or sensitive features by the next rain).
15. Sediment must be removed from sediment traps or sedimentation ponds not later than when design capacity has been reduced by 50%. A permanent stake will be provided that can indicate when the sediment occupies 50% of the basin volume.
16. Litter, construction debris, and construction chemicals exposed to stormwater shall be prevented from becoming a pollutant source for stormwater discharges (e.g., screening outfalls, picked up daily).

Soil Stabilization Practices

Examples: establishment of temporary vegetation, establishment of permanent vegetation, mulching, geotextiles, sod stabilization, vegetative buffer strips, protection of trees, or preservation of mature vegetation.

17. **Attachment J - Schedule of Interim and Permanent Soil Stabilization Practices.** A schedule of the interim and permanent soil stabilization practices for the site is attached.

18. Records must be kept at the site of the dates when major grading activities occur, the dates when construction activities temporarily or permanently cease on a portion of the site, and the dates when stabilization measures are initiated.
19. Stabilization practices must be initiated as soon as practicable where construction activities have temporarily or permanently ceased.

Administrative Information

20. All structural controls will be inspected and maintained according to the submitted and approved operation and maintenance plan for the project.
21. If any geologic or manmade features, such as caves, faults, sinkholes, etc., are discovered, all regulated activities near the feature will be immediately suspended. The appropriate TCEQ Regional Office shall be immediately notified. Regulated activities must cease and not continue until the TCEQ has reviewed and approved the methods proposed to protect the aquifer from any adverse impacts.
22. Silt fences, diversion berms, and other temporary erosion and sediment controls will be constructed and maintained as appropriate to prevent pollutants from entering sensitive features discovered during construction.

SPILL RESPONSE ACTIONS

If there is an accidental spill on site, the contractor shall respond with appropriate action. The contractor will be required to contact the owner and in turn the owner will contact the TCEQ in the event of a spill on site. In addition to the following guidance, reference the latest version of TCEQ's Technical Guidance Manual (TGM) rg-348 Section 1.4.16.

GENERAL MEASURES

1. To the extent that the work can be accomplished safely, spills of oil, petroleum products, substances listed under 40 CFR parts 110, 117, and 302, and sanitary and septic wastes should be contained and cleaned up immediately.
2. Store hazardous materials and wastes in covered containers and protect from vandalism.
3. Place a stockpile of spill cleanup materials where it will be readily accessible.
4. Train employees in spill prevention and cleanup.
5. Designate responsible individuals to oversee and enforce control measures.
6. Spills should be covered and protected from stormwater runoff during rainfall to the extent that it doesn't compromise clean-up activities.
7. Do not bury or wash spills with water.
8. Store and dispose of used clean up materials, contaminated materials, and recovered spill material that is no longer suitable for the intended purpose in conformance with the provisions in applicable BMPs.
9. Do not allow water used for cleaning and decontamination to enter storm drains or watercourses. Collect and dispose of contaminated water in accordance with applicable regulations.
10. Contain water overflow or minor water spillage and do not allow it to discharge into drainage facilities or watercourses.
11. Place Material Safety Data Sheets (MSDS), as well as proper storage, cleanup, and spill reporting instructions for hazardous materials stored or used on the project site in an open, conspicuous, and accessible location.
12. Keep waste storage areas clean, well-organized, and equipped with ample cleanup supplies as appropriate for the materials being stored. Perimeter controls, containment structures, covers, and liners should be repaired or replaced as needed to maintain proper function.

CLEAN UP

1. Clean up leaks and spills immediately.
2. Use a rag for small spills on paved surfaces, a damp mop for general cleanup, and absorbent material for larger spills. If the spilled material is hazardous, then the used cleanup materials are also hazardous and must be disposed of as hazardous waste.
3. Never hose down or bury dry material spills. Clean up as much of the material as possible and dispose of properly. See the waste management BMPs in this section for specific information.

MINOR SPILLS

1. Minor spills typically involve small quantities of oil, gasoline, paint, etc. Which can be controlled by the first responder at the discovery of the spill.
2. Use absorbent materials on small spills rather than hosing down or burying the spill.
3. Absorbent materials should be promptly removed.
4. Follow the practice below for a minor spill:
 - Contain the spread of the spill.
 - Recover spilled materials.
 - Clean the contaminated area and properly dispose of contaminated materials.

SEMI-SIGNIFICANT SPILLS

Semi-significant spills still can be controlled by the first responder along with the aid of other personnel such as laborers and the foreman, etc. This response may require the cessation of all other activities.

Spills should be cleaned up immediately:

1. Contain spread of the spill.
2. Notify the project foreman immediately.
3. If the spill occurs on paved or impermeable surfaces, clean up using "dry" methods (absorbent materials, cat litter and/or rags). Contain the spill by encircling with absorbent materials and do not let the spill spread widely.
4. If the spill occurs in dirt areas, immediately contain the spill by constructing an earthen dike. Dig up and properly dispose of contaminated soil.
5. If the spill occurs during rain, cover spill with tarps or other material to prevent contaminating runoff.

SIGNIFICANT/HAZARDOUS SPILLS

For significant or hazardous spills that are in reportable quantities:

1. Notify the TCEQ by telephone as soon as possible and within 24 hours at (512)339-2929 (Austin) or 210-490-3096 (San Antonio) between 8 AM and 5 PM. After hours, contact the Environmental Release Hotline at 1-800-832-8224. It is the contractor's responsibility to have all emergency phone numbers at the construction site.
2. For spills of federal reportable quantities, in conformance with the requirements in 40 CFR parts 110,119, and 302, the contractor should notify the National Response Center at (800) 424-8802.
3. Notification should first be made by telephone and followed up with a written report.
4. The services of a spills contractor or a Haz-Mat team should be obtained immediately. Construction personnel should not attempt to clean up until the appropriate and qualified staffs have arrived at the job site.
5. Other agencies which may need to be consulted include, but not limited to, the City Police Department, County Sheriff Office, Fire Departments, etc.

VEHICLE AND EQUIPMENT MAINTENANCE

1. If maintenance must occur onsite, use a designated area and a secondary containment, located away from drainage courses, to prevent the runoff of stormwater and the runoff of spills.
2. Regularly inspect onsite vehicles and equipment for leaks and repair immediately
3. Check incoming vehicles and equipment (including delivery trucks, and employee and subcontractor vehicles) for leaking oil and fluids. Do not allow leaking vehicles or equipment onsite.
4. Always use secondary containment, such as a drain pan or drop cloth, to catch spills or leaks when removing or changing fluids.
5. Place drip pans or absorbent materials under paving equipment when not in use.
6. Use absorbent materials on small spills rather than hosing down or burying the spill. Remove the absorbent materials promptly and dispose of properly.
7. Promptly transfer used fluids to the proper waste or recycling drums. Don't leave full drip pans or other open containers lying around.
8. Oil filters disposed of in trashcans or dumpsters can leak oil and pollute stormwater. Place the oil filter in a funnel over a waste oil-recycling drum to drain excess oil before disposal. Oil filters can also be recycled. Ask the oil supplier or recycler about recycling oil filters.
9. Store cracked batteries in a non-leaking secondary container. Do this with all cracked batteries even if you think all the acid has drained out. If you drop a battery, treat it as if it is cracked. Put it into the containment area until you are sure it is not leaking.

VEHICLE AND EQUIPMENT FUELING

1. If fueling must occur on site, use designated areas, located away from drainage courses, to prevent the runoff of stormwater and the runoff of spills.
2. Discourage "topping off" of fuel tanks.
3. Always use secondary containment, such as a drain pan, when fueling to catch spills/ leaks.

POTENTIAL SOURCES OF CONTAMINATION

Potential Source: Oil, grease, fuel, and hydraulic fluid contamination from construction equipment and vehicle dripping.

Preventative Measures: Vehicle maintenance when possible will be performed within the construction staging area or a local maintenance shop.

Potential Source: Miscellaneous trash and litter from construction workers and material wrappings.

Preventative Measures: Trash containers will be placed throughout the site to encourage proper disposal of trash.

Potential Source: Silt leaving the site.

Preventative Measures: Contractor will install all temporary best management practices prior to start of construction including the stabilized construction entrance to prevent tracking onto adjoining streets.

Potential Source: Construction Debris.

Preventative Measures: Construction debris will be monitored daily by contractor. Debris will be collected weekly and placed in disposal bins. Situations requiring immediate attention will be addressed on a case by case basis.

Potential Source: Soil and Mud from Construction Vehicle tires as they leave the site.

Preventative Measures: A stabilized construction exit shall be utilized as vehicles leave the site. Any soil, mud, etc. carried from the project onto public roads shall be cleaned up within 24 hours.

Potential Source: Sediment from soil, sand, gravel and excavated materials stock piled on site.

Preventative Measures: Silt fence shall be installed on the down gradient side of the stock piled materials. Reinforced rock berms shall be installed at all downstream discharge locations.

Potential Source: Portable toilet spill.

Preventative Measures: Toilets on the site will be emptied on a regular basis by the contracted toilet company.

SEQUENCE OF MAJOR ACTIVITIES

Intended Schedule of Sequence of Major Activities:

1. Installation of BMPs
 - a. Appropriate Temporary BMPs:
 - i. Stabilized Construction Entrance/Exit
 - ii. Construction Staging Area
2. Site Clearing Activities (±4.32 Acres)
 - a. Appropriate Temporary BMPs:
 - i. Stabilized Construction Entrance/Exit
 - ii. Silt Fence
 - iii. Inlet Protection/Rock Berm
 - iv. Tree Protection
 - v. Construction Staging Area
3. Earthwork & Grading (±4.32 Acres)
 - a. Appropriate Temporary BMPs:
 - i. Stabilized Construction Entrance/Exit
 - ii. Silt Fence
 - iii. Inlet Protection/Rock Berm
 - iv. Tree Protection
 - v. Construction Staging Area
4. Construction of Utilities
5. Paving Activities
 - a. Subgrade
 - b. Base
 - c. Pavement
6. Civil Site Work
7. Soil Stabilization
 - a. Appropriate Temporary BMPs:
 - i. Stabilized Construction Entrance/Exit
 - ii. Silt Fence
 - iii. Inlet Protection/Rock Berm
 - iv. Tree Protection
 - v. Construction Staging Area
8. Site cleanup and Removal of BMPs

TEMPORARY BEST MANAGEMENT PRACTICES AND MEASURES

- A:** A small amount of up-gradient runoff currently flows across the project area from Lot 10 and 15. The proposed development on the project site will not change the drainage pattern of the existing condition. Therefore, additional Temporary Best Management Practices and Measures to prevent pollution of surface and ground water will not be required.

Perimeter swales, dikes and slope drains will not be required due to no amount of storm water originating up-gradient from the site. Existing trees and vegetation will be protected to help maintain a stable ground surface and prevent loss of valuable topsoil. Stabilizing measures will be applied, to the maximum extent practicable, after the removal of any vegetative cover and/or altering the soil structure by clearing, grading, and compacting.

- B:** The BMPs for this project are designed to allow water to pass through after sedimentation has occurred. Existing flow patterns will be maintained to any naturally-occurring sensitive features that are discovered during construction.
- C:** As identified in the Geologic Assessment three (3) features were found within the boundaries of the project. The identified feature was not considered natural and sensitive, therefore, Temporary Best Management Practices and Measures to prevent pollutants from entering sensitive features will not be required at this time. The temporary on-site Temporary Best Management Practices and Measures will be used to treat stormwater runoff before it leaves the project and prevent pollutants from entering into surface streams or any sensitive features off-site.
- D:** According to the Geologic Assessment three (3) naturally occurring geologic features were identified during the geologic assessment. The identified feature was not considered sensitive, therefore, Temporary Best Management Practices and Measures used for maintaining flow to naturally -occurring sensitive features identified in the geologic assessment will not be required. The owner, geologist and engineer of record shall be notified immediately if any naturally-occurring sensitive features identified in either an executive director review, or during excavation, blasting, or construction. A Solution Feature Discovery Notification Form will then be submitted to the Texas Commission of Environmental Quality for review.

Feature Discovery Notification Form will then be submitted to the Texas Commission of Environmental Quality for review.

REQUEST TO TEMPORARILY SEAL A FEATURE

There will be no temporary sealing of any naturally occurring features on site.

STRUCTURAL PRACTICES

Structural Practices

Structural practices will be installed to prevent pollution caused by contaminated storm water runoff discharge from exposed areas of the site. Perimeter swales, dikes and slope drains used to divert flows away from exposed soils will not be required due to the small amount of storm water that originates up-gradient from the site. All structural practices will be installed prior to the removal of any vegetative cover and/or altering the soil structure by clearing, grading, and compacting. The location of all structural practices for the subject site is shown on the Water Quality Plan (**Exhibit 1**). The following describes the structural practices used.

Concrete Washout Areas

The purpose of concrete washout areas is to prevent or reduce the discharge of pollutants to storm water from concrete waste by conducting washout offsite, performing onsite washout in a designated area, and training employees and subcontractors.

The following steps will help reduce storm water pollution from concrete wastes:

1. Incorporate requirements for concrete waste management into material supplier and subcontractor agreements.
2. Avoid mixing excess amounts of fresh concrete.
3. Perform washout of concrete trucks in designated areas only.
4. Do not wash out concrete trucks into storm drains, open ditches, streets, or streams.
5. Do not allow excess concrete to be dumped onsite, except in designated areas.

For onsite washout:

1. Locate washout area at least 50 feet from sensitive features, storm drains, open ditches, or water bodies. Do not allow runoff from this area by constructing a temporary pit or bermed area large enough for liquid and solid waste.
2. Wash out wastes into the temporary pit where the concrete can set, be broken up, and then disposed properly.

Below grade concrete washout facilities are typical. These consist of a lined excavation sufficiently large to hold expected volume of washout material. Above grade facilities are used if excavation is not practical. Temporary concrete washout facility (type above grade) should be constructed as shown on the details at the end of this section, with sufficient quantity and volume to contain all liquid and concrete waste generated by washout operations. Plastic lining material should be a minimum of 10mil in polyethylene sheeting and should be free of holes, tears, or other defects that compromise the impermeability of the material.

When temporary concrete washout facilities are no longer required for the work, the hardened concrete should be removed and disposed of. Materials used to construct temporary concrete washout facilities should be removed from the site of the work and disposed of. Holes, depressions or other ground disturbance caused by the removal of the temporary concrete washout facilities should be backfilled and repaired.

Silt Fence

A silt fence is a barrier consisting of geotextile fabric supported by metal posts to prevent soil and sediment loss from a site. When properly used, silt fences can be highly effective at controlling sediment from disturbed areas. They cause runoff to pond, allowing heavier solids to settle out. If not properly installed, silt fences are not likely to be effective.

The purpose of a silt fence is to intercept and detain water-borne sediment from unprotected areas of a limited extent. Silt fence is used during the period of construction near the perimeter of a disturbed area to intercept sediment while allowing water to percolate through. This fence should remain in place until the disturbed area is permanently stabilized. Silt fence should not be used where there is a concentration of water in a channel or drainage way. If concentrated flow occurs after installation, corrective action must be taken such as placing a rock berm in the areas of concentrated flow.

Silt fencing within the site may be temporarily moved during the day to allow construction activity provided it is replaced and properly anchored to the ground at the end of the day. Silt fences on the perimeter of the site or around drainage ways should not be moved at any time.

Materials:

1. Silt fence material should be polypropylene, polyethylene or polyamide woven or nonwoven fabric. The fabric width should be 36 inches, with a minimum unit weight of 4.5 oz/yd, mullen burst strength exceeding 190 lb/in², ultraviolet stability exceeding 70%, and minimum apparent opening size of U.S. Sieve No. 30.

**Edwards Aquifer Group
Water Pollution Abatement Plan
Temporary Stormwater Section**

Attachment F

2. Fence posts should be made of hot rolled steel, at least 4 feet long with Tee or Ybar cross section, surface painted or galvanized, minimum nominal weight 1.25 lb/ft, and Brindell hardness exceeding 140.
3. Woven wire backing to support the fabric should be galvanized 2" x 4" welded wire, 12 gauge minimum.

Installation:

1. Steel posts, which support the silt fence, should be installed on a slight angle toward the anticipated runoff source. Post must be embedded a minimum of 1-foot deep and spaced not more than 8 feet on center. Where water concentrates, the maximum spacing should be 6 feet.
2. Lay out fencing down-slope of disturbed area, following the contour as closely as possible. The fence should be sited so that the maximum drainage area is $\frac{1}{4}$ acre/100 feet of fence.
3. The toe of the silt fence should be trenched in with a spade or mechanical trencher, so that the down-slope face of the trench is flat and perpendicular to the line of flow. Where fence cannot be trenched in (e.g., pavement or rock outcrop), weight fabric flap with 3 inches of pea gravel on uphill side to prevent flow from seeping under fence.
4. The trench must be a minimum of 6 inches deep and 6 inches wide to allow for the silt fence fabric to be laid in the ground and backfilled with compacted material.
5. Silt fence should be securely fastened to each steel support post or to woven wire, which is in turn attached to the steel fence post. There should be a 3-foot overlap, securely fastened where ends of fabric meet.
6. Silt fence should be removed when the site is completely stabilized so as not to block or impede storm flow or drainage.

Common Trouble Points:

1. Fence not installed along the contour causing water to concentrate and flow over the fence.
2. Fabric not seated securely to ground (runoff passing under fence)
3. Fence not installed perpendicular to flow line (runoff escaping around sides)
4. Fence treating too large an area, or excessive channel flow (runoff overtops or collapses fence)

Temporary Construction Entrance/Exit

**Edwards Aquifer Group
Water Pollution Abatement Plan
Temporary Stormwater Section**

Attachment F

The purpose of a temporary gravel construction entrance is to provide a stable entrance/exit condition from the construction site and keep mud and sediment off public roads. A stabilized construction entrance is a stabilized pad of crushed stone located at any point traffic will be entering or leaving the construction site from a public right-of-way, street, alley, sidewalk, or parking area. The purpose of a stabilized construction entrance is to reduce or eliminate the tracking or flowing of sediment onto public rights-of-way. This practice should be used at all points of construction ingress and egress.

Excessive amounts of mud can also present a safety hazard to roadway users. To minimize the amount of sediment loss to nearby roads, access to the construction site should be limited to as few points as possible and vegetation around the perimeter should be protected where access is not necessary. A rock stabilized construction entrance should be used at all designated access points.

Materials:

1. The aggregate should consist of 4 to 8 inch washed stone over a stable foundation as specified in the plan.
2. The aggregate should be placed with a minimum thickness of 8 inches.
3. The geotextile fabric should be designed specifically for use as a soil filtration media with an approximate weight of 6 oz/yd², a mullen burst rating of 140 lb/in², and an equivalent opening size greater than a number 50 sieve.
4. If a washing facility is required, a level area with a minimum of 4 inch diameter washed stone or commercial rack should be included in the plans. Divert wastewater to a sediment trap or basin.

Installation: (North Carolina, 1993)

1. Avoid curves on public roads and steep slopes. Remove vegetation and other objectionable material from the foundation area. Grade crown foundation for positive drainage.
2. The minimum width of the entrance/exit should be 12 feet or the full width of exit roadway, whichever is greater.
3. The construction entrance should be at least 50 feet long.
4. If the slope toward the road exceeds 2%, construct a ridge, 6 to 8 inches high with 3:1 (H:V) side slopes, across the foundation approximately 15 feet from the entrance to divert runoff away from the public road.

5. Place geotextile fabric and grade foundation to improve stability, especially where wet conditions are anticipated.
6. Place stone to dimensions and grade shown on plans. Leave surface smooth and slope for drainage.
7. Divert all surface runoff and drainage from the stone pad to a sediment trap or basin.
8. Install pipe under pad as needed to maintain proper public road drainage.

Common trouble points:

1. Inadequate runoff control – sediment washes onto public road.
2. Stone too small or geotextile fabric absent, results in muddy condition as stone is pressed into soil.
3. Pad too short for heavy construction traffic – extend pad beyond the minimum 50 foot length as necessary.
4. Pad not flared sufficiently at road surface, results in mud being tracked on to road and possible damage to road edge.
5. Unstable foundation – use geotextile fabric under pad and/or improve foundation drainage.

Inlet Protection

Storm sewers that are made operational prior to stabilization of the associated drainage areas can convey large amounts of sediment to natural drainage ways. In case of extreme sediment loading, the storm sewer itself may clog and lose a major portion of its capacity. To avoid these problems, it is necessary to prevent sediment from entering the system at the inlets. The following guidelines for inlet protection are based primarily on recommendations by the Virginia Dept. of Conservation and Recreation (1992) and the North Central Texas Council of Governments (NCTCOG, 1993b).

In developments for which drainage is to be conveyed by underground storm sewers (i.e., streets with curbs and gutters), all inlets that may receive storm runoff from disturbed areas should be protected. Temporary inlet protection is a series of different measures that provide protection against silt transport or accumulation in storm sewer systems. This clogging can greatly reduce or completely stop the flow in the pipes. The different measures are used for different site conditions and inlet types.

**Edwards Aquifer Group
Water Pollution Abatement Plan
Temporary Stormwater Section**

Attachment F

5. Place geotextile fabric and grade foundation to improve stability, especially where wet conditions are anticipated.
6. Place stone to dimensions and grade shown on plans. Leave surface smooth and slope for drainage.
7. Divert all surface runoff and drainage from the stone pad to a sediment trap or basin.
8. Install pipe under pad as needed to maintain proper public road drainage.

Common trouble points:

1. Inadequate runoff control – sediment washes onto public road.
2. Stone too small or geotextile fabric absent, results in muddy condition as stone is pressed into soil.
3. Pad too short for heavy construction traffic – extend pad beyond the minimum 50 foot length as necessary.
4. Pad not flared sufficiently at road surface, results in mud being tracked on to road and possible damage to road edge.
5. Unstable foundation – use geotextile fabric under pad and/or improve foundation drainage.

Inlet Protection

Storm sewers that are made operational prior to stabilization of the associated drainage areas can convey large amounts of sediment to natural drainage ways. In case of extreme sediment loading, the storm sewer itself may clog and lose a major portion of its capacity. To avoid these problems, it is necessary to prevent sediment from entering the system at the inlets. The following guidelines for inlet protection are based primarily on recommendations by the Virginia Dept. of Conservation and Recreation (1992) and the North Central Texas Council of Governments (NCTCOG, 1993b).

In developments for which drainage is to be conveyed by underground storm sewers (i.e., streets with curbs and gutters), all inlets that may receive storm runoff from disturbed areas should be protected. Temporary inlet protection is a series of different measures that provide protection against silt transport or accumulation in storm sewer systems. This clogging can greatly reduce or completely stop the flow in the pipes. The different measures are used for different site conditions and inlet types.

Care should be taken when choosing a specific type of inlet protection. Field experience has shown that inlet protection that causes excessive ponding in an area of high construction activity may

**Edwards Aquifer Group
Water Pollution Abatement Plan
Temporary Stormwater Section**

Attachment F

become so inconvenient that it is removed or bypassed, thus transmitting sediment-laden flows unchecked. In such situations, a structure with an adequate overflow mechanism should be utilized.

It should also be noted that inlet protection devices are designed to be installed on construction sites and not on streets and roads open to the public. When used on public streets these devices will cause ponding of runoff, which can cause minor flooding and can present a traffic hazard. An example of appropriate siting would be a new subdivision where the storm drain system is installed before the area is stabilized and the streets open to the general public. When construction occurs adjacent to active streets, the sediment should be controlled on site and not on public thoroughfares. Occasionally, roadwork or utility installation will occur on public roads. In these cases, inlet protection is an appropriate temporary BMP.

The following inlet protection devices are for drainage areas of one acre or less. Runoff from larger disturbed areas should be routed to a temporary sediment trap or basin. Filter barrier protection using silt fence is appropriate when the drainage area is less than one acre and the basin slope is less than five percent. This type of protection is not applicable in paved areas.

Block and gravel protection is used when flows exceed 0.5 cubic feet per second and it is necessary to allow for overtopping to prevent flooding. This form of protection is also useful for curb type inlets as it works well in paved areas.

Wire mesh and gravel protection is used when flows exceed 0.5 cubic feet per second and construction traffic may occur over the inlet. This form of protection may be used with both curb and drop inlets.

Excavated impoundment protection around a drop inlet may be used for protection against sediment entering a storm drain inlet. With this method, it is necessary to install weep holes to allow the impoundment to drain completely. If this measure is implemented, the impoundment should be sized such that the volume of excavation is 3,600 cubic feet per acre (equivalent to 1 inch of runoff) of disturbed area entering the inlet.

Materials:

1. Filter fabric should be a nylon reinforced polypropylene fabric which meets the following minimum criteria: Tensile Strength, 90 lbs.; Puncture Rating, 60 lbs.; Mullen Burst Rating, 280 psi; Apparent Opening Size, U.S. Sieve No. 70.
2. Posts for fabric should be 2" x 4" pressure treated wood stakes or galvanized steel, tubular in cross-section or they may be standard fence "T" posts.
3. Concrete blocks should be standard 8" x 8" x 16" concrete masonry units.

Edwards Aquifer Group
Water Pollution Abatement Plan
Temporary Stormwater Section

Attachment F

4. Wire mesh should be standard hardware cloth or comparable wire mesh with an opening size not to exceed 1/2 inch.

Guidelines for installation:

Silt Fence Drop Inlet Protection

1. Silt fence should conform to the specifications listed above and should be cut from a continuous roll to avoid joints.
2. For stakes, use 2 x 4-inch wood or equivalent metal with a minimum length of 3 feet.
3. Space stakes evenly around the perimeter of the inlet a maximum of 3 feet apart, and securely drive them into the ground, approximately 18 inches deep.
4. To provide needed stability to the installation, a frame with 2 x 4- inch wood strips around the crest of the overflow area at a maximum of 1½ feet above the drop inlet crest should be provided.
5. Place the bottom 12 inches of the fabric in a trench and backfill the trench with 12 inches of compacted soil.
6. Fasten fabric securely by staples or wire to the stakes and frame. Joints must be overlapped to the next stake.
7. It may be necessary to build a temporary dike on the down slope side of the structure to prevent bypass flow.

If the drop inlet is above the finished grade, the grate may be completely covered with filter fabric. The fabric should be securely attached to the entire perimeter of the inlet using 1"x 2" wood strips and appropriate fasteners.

Gravel and Wire Mesh Drop Inlet Sediment Filter

1. Wire mesh should be laid over the drop inlet so that the wire extends a minimum of 1 foot beyond each side of the inlet structure. Wire mesh with 1/2-inch openings should be used. If more than one strip of mesh is necessary, the strips should be overlapped.
2. Coarse aggregate should be placed over the wire mesh. The depth of stone should be at least 12 inches over the entire inlet opening. The stone should extend beyond the inlet opening at least 18 inches on all sides.
3. If the stone filter becomes clogged with sediment so that it no longer adequately performs its function, the stones must be pulled away from the inlet, cleaned and/or replaced.

**Edwards Aquifer Group
Water Pollution Abatement Plan
Temporary Stormwater Section**

Attachment F

Note: This filtering device has no overflow mechanism; therefore, ponding is likely especially if sediment is not removed regularly. This type of device should never be used where overflow may endanger an exposed fill slope. Consideration should also be given to the possible effects of ponding on traffic movement, nearby structures, working areas, adjacent property, etc.

Block and Gravel Drop Inlet Sediment Filter

1. Place concrete blocks lengthwise on their sides in a single row around the perimeter of the inlet, with the ends of adjacent blocks abutting. The height of the barrier can be varied, depending on design needs, by stacking combinations of 4-inch, 8-inch and 12- inch wide blocks. The barrier of blocks should be between 12 and 24 inches high.
2. Wire mesh should be placed over the outside vertical face (webbing) of the concrete blocks to prevent stone from being washed through the holes in the blocks. Wire mesh with 1/2- inch openings should be used.
3. Stone should be piled against the wire to the top of the block barrier.
4. If the stone filter becomes clogged with sediment so that it no longer adequately performs its function, the stone must be pulled away from the blocks, cleaned and replaced.

Block and Gravel Curb Inlet Sediment Filter

1. Two concrete blocks should be placed on their sides abutting the curb at either side of the inlet opening.
2. A 2"X4" stud should be cut and placed through the outer holes of each spacer block to help keep the front blocks in place.
3. Concrete blocks should be placed on their sides across the front of the inlet and abutting the spacer blocks.
4. Wire mesh should be placed over the outside vertical face (webbing) of the concrete blocks to prevent stone from being washed through the holes in the blocks. Wire mesh with 1/2- inch openings should be used.
5. Coarse aggregate should be piled against the wire to the top of the barrier.
6. If the stone filter becomes clogged with sediment so that it no longer adequately performs its function, the stone must be pulled away from the blocks, cleaned and/or replaced.

Edwards Aquifer Group
Water Pollution Abatement Plan
Temporary Stormwater Section

Attachment F

Excavated Drop Inlet Sediment Trap

1. The excavated trap should be sized to provide a minimum storage capacity calculated at 3,600 cubic feet per acre of drainage area. A trap should be no less than 1-foot nor more than 2 feet deep measured from the top of the inlet structure. Side slopes should not be steeper than 2:1.
2. The slope of the basin may vary to fit the drainage area and terrain. Observations must be made to check trap efficiency and modifications should be made as necessary to ensure satisfactory trapping of sediment. Where an inlet is located so as to receive concentrated flows, such as in a highway median, it is recommended that the basin have a rectangular shape in a 2:1 (length/width) ratio, with the length oriented in the direction of the flow.
3. Sediment should be removed and the trap restored to its original dimensions when the sediment has accumulated to one-half the design depth of the trap. Removed sediment should be deposited in a suitable area and in a manner such that it will not erode.

Curb Inlet Protection with 2-inch x 4-inch Wooden Weir

1. Attach a continuous piece of wire mesh (30-inch minimum width x inlet throat length plus 4 feet) to the 2-inch x 4-inch wooden weir (with a total length of throat length plus 2 feet). Wood should be "construction grade" lumber.
2. Place a piece of approved filter cloth of the same dimensions as the wire mesh over the wire mesh and securely attach to the 2-inch x 4-inch weir.
3. Securely nail the 2-inch x 4-inch weir to the 9-inch long vertical spacers which are to be located between the weir and inlet face at a maximum 6-foot spacing.
4. Place the assembly against the inlet throat and nail 2-foot (minimum) lengths of 2-inch x 4-inch board to the top of the weir at spacer locations. These 2-inch x 4-inch anchors should extend across the inlet tops and be held in place by sandbags or alternate weight.
5. The assembly should be placed so that the end spacers are a minimum 1 foot beyond both ends of the throat opening.
6. Form the wire mesh and filter cloth to the concrete gutter and against the face of curb on both sides of the inlet. Place coarse aggregate over the wire mesh and filter fabric in such a manner as to prevent water from entering the inlet under or around the filter cloth.
7. This type of protection should be inspected frequently and the filter cloth and stone replaced when clogged with sediment.

Edwards Aquifer Group
Water Pollution Abatement Plan
Temporary Stormwater Section

Attachment F

8. Assure that storm flow does not bypass inlet by installing temporary earth or asphalt dikes directing flow into inlet.

Bagged Gravel Inlet Filter

Sandbags filled with pea gravel can also be used to construct a sediment barrier around curb and drain inlets. The sandbags should be filled with washed pea gravel and stacked to form a continuous barrier about 1 foot high around the inlets. The bags should be tightly abutted against each other to prevent runoff from flowing between the bags.

Common Trouble Points:

1. Gaps between the inlet protection and the curb (flows bypass around side of filter).
2. Filter fabric skirt not anchored to pavement (flows pass under filter).

DRAINAGE AREA MAP

The Existing and Proposed Drainage Area Maps are provided at the end of this report in **Exhibit 3**. Erosion and sediment controls will be used within each disturbed drainage area as discussed in **Attachment D**.

TEMPORARY SEDIMENT POND(S) PLANS AND CALCULATIONS

The proposed development will not disturb areas over 10 acres at one time within a common drainage watershed. Therefore, temporary sediment pond(s) plans and calculations will not be require.

INSPECTION AND MAINTENANCE FOR BMPs

MAINTENANCE

All temporary and permanent erosion and sediment control BMPs will be maintained and repaired as needed to assure continued performance of their intended function. All maintenance and repair of BMPs will be conducted in accordance with manufacturers' specifications.

All temporary erosion and sediment control BMPs will be removed within 30 days after final site stabilization is achieved or after the temporary BMPs are no longer needed. Trapped sediment will be removed or stabilized on site. Disturbed soil areas resulting from removal of BMPs or vegetation will be permanently stabilized as soon as possible.

Erosion and sediment controls are designed to prevent soil erosion and sediment migration offsite, to the extent practicable, which may result from construction activity. This design considers local topography, soil type, and rainfall.

Control measures must be installed and maintained according to the manufacturer's specifications. If periodic inspections or other information indicates a control has been used inappropriately, or incorrectly, the permittee must replace or modify the control for site situations.

If sediment ponds are utilized the Sediment must be removed from sediment traps or sedimentation ponds when design capacity has been reduced by 50%.

If sediment escapes the construction site, off-site accumulations of sediment must be removed at a frequency sufficient to minimize off-site impacts, and whenever feasible, prior to the next rain event.

The controls must be installed, maintained, and operated in a manner that will limit, to the extent practicable, offsite transport of litter, construction debris, and construction materials.

INSPECTIONS

An inspection will be performed by the qualified personnel, as designated by the permittee, on a weekly basis and after any rainfall event. An inspection and maintenance report shall be made per inspection. An inspection form has been included in this report. Based on the inspection results, the controls shall be corrected before the next scheduled inspection.

A log of inspection results will be maintained on-site and will include the name of the inspector, date, major observations, and necessary corrective measures. Reports of maintenance and inspection activities will be maintained on-site, in conformance with the TPDES permit conditions. Reports must identify any incidents of non-compliance. Where a report does not identify any incidents of non-compliance, the report must contain a certification that the facility or site is in compliance with the WPAP. This report must be signed by the responsible party.

Major observations shall, at a minimum, include the following:

- The locations of discharges of sediment or other pollutants from the site;
- Locations of BMPs that need to be maintained;
- Locations of BMPs that failed to operate as designed or proved inadequate for a particular location; and
- Location where additional BMPs are needed.

All needed repairs or modifications will be reported to the contractors to permit the timely implementation of required actions. Necessary repairs or modifications will be implemented within seven days of inspection. The WPAP will be modified within seven days to reflect any modifications to measures as a result of inspection.

The WPAP must be amended whenever there is a change in design, construction, operation or maintenance that has a significant effect on the discharge of pollutants to the waters of the United States that was not addressed in the WPAP.

Edwards Aquifer Group
Water Pollution Abatement Plan
Temporary Stormwater Section

Attachment I

The WPAP must be amended when inspections or investigations by site operations, local, state or federal officials indicate that the WPAP is proving ineffective in eliminating or significantly minimizing pollutants from the construction site or otherwise is not achieving the general objectives of controlling pollutants in storm water discharges associated with construction activity.

INSPECTION FORM

Project Name: Owner (s)/Operator (s): Permit Numbers(s): Inspection Date:	NOT APPLICABLE	IN COMPLIANCE	NEEDS CORRECTION	COMMENTS
RECORD KEEPING				
SWP3 Current				
NOI and Permit Posted				
BEST MANAGEMENT PRACTICES (BMPs)				
Vegetative Buffers				
Soil Covering(Including mulch and temporary vegetation)				
Outlet Protection				
Sediment Control Basins				
Silt Fence				
Stabilized Entrances/Exits				
Construction Staging Areas				
Inlet Protection				
Gravel Filter Bags				
Vegetated Filter Strip				
Concrete Truck Washout Pit				
Trash Receptacles				
General Site Cleanliness				
Other _____				
Other _____				
Other _____				

Edwards Aquifer Group
Water Pollution Abatement Plan
Temporary Stormwater Section

Attachment I

MAJOR OBSERVATIONS

CERTIFICATION

"I certify under penalty of law that this document and all attachments were prepared under my direction or supervision in accordance with a system designed to assure that qualified personnel properly gather and evaluate the information submitted. Based on my inquiry of the person or persons who manage the system, or those persons directly responsible for gathering the information, the information submitted is, to the best of my knowledge and belief, true, accurate, and complete. I am aware there are significant penalties for submitting false information, including the possibility of fine and imprisonment for knowing violations."

"I further certify I am an authorized signatory in accordance with the provisions of 30 TAC §305.128."

INSPECTOR NAME/SIGNATURE:

DATE:

(Inspector must attach a brief summary of qualifications to this report.)

OWNER NAME/SIGNATURE:

DATE:

SCHEDULE OF INTERIM AND PERMANENT SOIL STABILIZATION

Construction practices shall disturb the minimal amount of existing ground cover as required for land clearing, grading, and construction activity for the shortest amount of time possible to minimize the potential of erosion and sedimentation from the site. Existing vegetation shall be maintained and left in place until it is necessary to disturb for construction activity. For this project the following stabilization practices will be implemented:

1. Hydraulic Mulch and Seeding: Disturbed areas subject to erosion shall be stabilized with hydraulic mulch and/or seeded and watered to provide interim stabilization. For areas that are not to be sodded as per the project landscaping plan, a minimum of 85% vegetative cover will be established to provide permanent stabilization.
2. Sodding and Wood Mulch: As per the project landscaping plan, Sodding and wood mulch will be applied to landscaped areas to provide permanent stabilization prior to project completion.

Records of the following shall be maintained by the permittee in the attached Project Timeline:

- a) The dates when major grading activities occur;
- b) The dates when construction activities temporarily or permanently cease on a portion of the site; and
- c) The dates when stabilization measures are initiated.

Stabilization measures must be initiated as soon as practical in portions of the site where construction activities have temporarily or permanently ceased, and except as provided in the following, must be initiated no more that fourteen (14) days after the construction activity in that portion of the site has temporarily or permanently ceased:

Where the initiation of stabilization measures by the 14th day after construction activity temporarily or permanently ceased is precluded by snow cover or frozen ground conditions, stabilization measures must be initiated as soon as practical.

Where construction activity on a portion of the site is temporarily ceased and earth disturbing activities will be resumed within twenty-one (21) days, temporary stabilization measures do not have to be initiated on that portion of the site.

In arid areas (areas with an average rainfall of 0-10 inches), semiarid areas (areas with an average annual rainfall of 10 to 20 inches), and areas experiencing droughts where the initiation of stabilization measures by the 14th day after construction activity has temporarily or permanently ceased is precluded by seasonably arid conditions, stabilization measures must be initiated as soon as practical. For interim stabilization during drought conditions best management practices will be implemented. These may include but are not limited to geotextile blankets and matting, hydromulch, diversion structures and/or structural controls such as silt fence and rock berms. These BMPs are to be maintained in accordance with the inspection/maintenance schedule provided in the Attachments.

PROJECT TIMELINE

DATES WHEN MAJOR GRADING ACTIVITIES OCCUR	
Date	Construction Activity

DATES WHEN CONSTRUCTION ACTIVITIES TEMPORARILY OR PERMANENTLY CEASE	
Date	Construction Activity

DATES WHEN STABILIZATION MEASURES ARE INITIATED	
Date	Stabilization Activity

PERMANENT STORMWATER SECTION

Permanent Stormwater Section

Texas Commission on Environmental Quality

for Regulated Activities on the Edwards Aquifer Recharge Zone and Relating to 30 TAC §213.5(b)(4)(C), (D)(li), (E), and (5), Effective June 1, 1999

To ensure that the application is administratively complete, confirm that all fields in the form are complete, verify that all requested information is provided, consistently reference the same site and contact person in all forms in the application, and ensure forms are signed by the appropriate party.

Note: Including all the information requested in the form and attachments contributes to more streamlined technical reviews.

Signature

To the best of my knowledge, the responses to this form accurately reflect all information requested concerning the proposed regulated activities and methods to protect the Edwards Aquifer. This **Permanent Stormwater Section** is hereby submitted for TCEQ review and executive director approval. The application was prepared by:

Print Name of Customer/Agent: Frank D. Corey, P.E.

Date: 06/22/2023

Signature of Customer/Agent



Regulated Entity Name: Elsewhere Garden Bar & Kitchen

Permanent Best Management Practices (BMPs)

Permanent best management practices and measures that will be used during and after construction is completed.

- Permanent BMPs and measures must be implemented to control the discharge of pollution from regulated activities after the completion of construction.
 N/A
- These practices and measures have been designed, and will be constructed, operated, and maintained to insure that 80% of the incremental increase in the annual mass loading of total suspended solids (TSS) from the site caused by the regulated activity is removed. These quantities have been calculated in accordance with technical guidance prepared or accepted by the executive director.
 The TCEQ Technical Guidance Manual (TGM) was used to design permanent BMPs and measures for this site.

A technical guidance other than the TCEQ TGM was used to design permanent BMPs and measures for this site. The complete citation for the technical guidance that was used is: _____

N/A

3. Owners must insure that permanent BMPs and measures are constructed and function as designed. A Texas Licensed Professional Engineer must certify in writing that the permanent BMPs or measures were constructed as designed. The certification letter must be submitted to the appropriate regional office within 30 days of site completion.

N/A

4. Where a site is used for low density single-family residential development and has 20 % or less impervious cover, other permanent BMPs are not required. This exemption from permanent BMPs must be recorded in the county deed records, with a notice that if the percent impervious cover increases above 20% or land use changes, the exemption for the whole site as described in the property boundaries required by 30 TAC §213.4(g) (relating to Application Processing and Approval), may no longer apply and the property owner must notify the appropriate regional office of these changes.

The site will be used for low density single-family residential development and has 20% or less impervious cover.

The site will be used for low density single-family residential development but has more than 20% impervious cover.

The site will not be used for low density single-family residential development.

5. The executive director may waive the requirement for other permanent BMPs for multi-family residential developments, schools, or small business sites where 20% or less impervious cover is used at the site. This exemption from permanent BMPs must be recorded in the county deed records, with a notice that if the percent impervious cover increases above 20% or land use changes, the exemption for the whole site as described in the property boundaries required by 30 TAC §213.4(g) (relating to Application Processing and Approval), may no longer apply and the property owner must notify the appropriate regional office of these changes.

Attachment A - 20% or Less Impervious Cover Waiver. The site will be used for multi-family residential developments, schools, or small business sites and has 20% or less impervious cover. A request to waive the requirements for other permanent BMPs and measures is attached.

The site will be used for multi-family residential developments, schools, or small business sites but has more than 20% impervious cover.

The site will not be used for multi-family residential developments, schools, or small business sites.

6. **Attachment B - BMPs for Upgradient Stormwater.**

- A description of the BMPs and measures that will be used to prevent pollution of surface water, groundwater, or stormwater that originates upgradient from the site and flows across the site is attached.
 - No surface water, groundwater or stormwater originates upgradient from the site and flows across the site, and an explanation is attached.
 - Permanent BMPs or measures are not required to prevent pollution of surface water, groundwater, or stormwater that originates upgradient from the site and flows across the site, and an explanation is attached.
7. **Attachment C - BMPs for On-site Stormwater.**
- A description of the BMPs and measures that will be used to prevent pollution of surface water or groundwater that originates on-site or flows off the site, including pollution caused by contaminated stormwater runoff from the site is attached.
 - Permanent BMPs or measures are not required to prevent pollution of surface water or groundwater that originates on-site or flows off the site, including pollution caused by contaminated stormwater runoff, and an explanation is attached.
8. **Attachment D - BMPs for Surface Streams.** A description of the BMPs and measures that prevent pollutants from entering surface streams, sensitive features, or the aquifer is attached. Each feature identified in the Geologic Assessment as sensitive has been addressed.
- N/A
9. The applicant understands that to the extent practicable, BMPs and measures must maintain flow to naturally occurring sensitive features identified in either the geologic assessment, executive director review, or during excavation, blasting, or construction.
- The permanent sealing of or diversion of flow from a naturally-occurring sensitive feature that accepts recharge to the Edwards Aquifer as a permanent pollution abatement measure has not been proposed.
 - Attachment E - Request to Seal Features.** A request to seal a naturally-occurring sensitive feature, that includes, for each feature, a justification as to why no reasonable and practicable alternative exists, is attached.
10. **Attachment F - Construction Plans.** All construction plans and design calculations for the proposed permanent BMP(s) and measures have been prepared by or under the direct supervision of a Texas Licensed Professional Engineer, and are signed, sealed, and dated. The plans are attached and, if applicable include:
- Design calculations (TSS removal calculations)
 - TCEQ construction notes
 - All geologic features
 - All proposed structural BMP(s) plans and specifications
- N/A

11. **Attachment G - Inspection, Maintenance, Repair and Retrofit Plan.** A plan for the inspection, maintenance, repairs, and, if necessary, retrofit of the permanent BMPs and measures is attached. The plan includes all of the following:
- Prepared and certified by the engineer designing the permanent BMPs and measures
 - Signed by the owner or responsible party
 - Procedures for documenting inspections, maintenance, repairs, and, if necessary retrofit
 - A discussion of record keeping procedures
- N/A
12. **Attachment H - Pilot-Scale Field Testing Plan.** Pilot studies for BMPs that are not recognized by the Executive Director require prior approval from the TCEQ. A plan for pilot-scale field testing is attached.
- N/A
13. **Attachment I -Measures for Minimizing Surface Stream Contamination.** A description of the measures that will be used to avoid or minimize surface stream contamination and changes in the way in which water enters a stream as a result of the construction and development is attached. The measures address increased stream flashing, the creation of stronger flows and in-stream velocities, and other in-stream effects caused by the regulated activity, which increase erosion that results in water quality degradation.
- N/A

Responsibility for Maintenance of Permanent BMP(s)

Responsibility for maintenance of best management practices and measures after construction is complete.

14. The applicant is responsible for maintaining the permanent BMPs after construction until such time as the maintenance obligation is either assumed in writing by another entity having ownership or control of the property (such as without limitation, an owner's association, a new property owner or lessee, a district, or municipality) or the ownership of the property is transferred to the entity. Such entity shall then be responsible for maintenance until another entity assumes such obligations in writing or ownership is transferred.
- N/A
15. A copy of the transfer of responsibility must be filed with the executive director at the appropriate regional office within 30 days of the transfer if the site is for use as a multiple single-family residential development, a multi-family residential development, or a non-residential development such as commercial, industrial, institutional, schools, and other sites where regulated activities occur.
- N/A

Edwards Aquifer Group
Water Pollution Abatement Plan
Permanent Storm Water Section

Attachment A

20% OR LESS IMPERVIOUS COVER WAIVER

Not applicable.

BMPs FOR UP-GRADIENT STORMWATER

Small amount of upgradient storm water runoff originates from Lot 10 and 15. The proposed development will not change the existing drainage condition. Therefore, additional permanent best management practices and measures to prevent pollution of surface and ground water will not be required.

BMPs FOR ON-SITE STORMWATER

One (1) permanent BMP device will be used to treat storm water runoff from the site. The required amount of pollutant load to be treated by the Jellyfish Filter is 1,324 pounds TSS.

A Jellyfish Filter will be constructed to treat the required pollutant load for the proposed development. The Jellyfish Filter has been designed to treat 1.539 acres of impervious cover and overtreated for 0.13 acres of uncaptured cover. Please reference **Attachment F** for design calculations. Construction plans for the Jellyfish Filter System are provided in Exhibit 2.

BMPs FOR SURFACE STREAMS

Not applicable. There are no existing surface streams onsite, therefore additional BMP's are not required besides the Jellyfish Filter to treat the water on the proposed site.

Edwards Aquifer Group
Water Pollution Abatement Plan
Permanent Storm Water Section

Attachment E

REQUEST TO SEAL A FEATURE

There will be no sealing of any naturally occurring features on site.

CONSTRUCTION PLANS

Calculations for the load removal requirements for the project and the load removal provided by the permanent BMP's are provided in the attached spreadsheet which have been signed and sealed by a professional engineer licensed in the state of Texas. The load removal requirements are derived from the equations from the technical guidance manual based upon project area and increase in impervious cover. Provided within the calculations is a summary of the amount of pollutant load required to be removed from the drainage areas and the amount of removal provided by the permanent BMP's.

All calculations, construction plans, details, specifications, and construction notes are provided in this section.

Project Name: **Elsewhere Garden Bar & Kitchen**
Date Prepared: **6/23/2023**

1. The Required Load Reduction for the total project:

Calculations from RG-348
Pages 3-27 to 3-30

Page 3-29 Equation 3.3: $L_M = 27.2(A_N \times P)$

$L_{M\text{TOTAL PROJECT}}$ = Required TSS removal resulting from the proposed development = 80% of increased load
 A_N = Net increase in impervious area for the project
P = Average annual precipitation, inches

Site Data: Determine Required Load Removal Based on the Entire Project

County = **Bexar**
Total project area included in plan * = **4.324** acres
Predevelopment impervious area within the limits of the plan * = **0.000** acres
Total post-development impervious area within the limits of the plan* = **1.622** acres
Total post-development impervious cover fraction * = **0.38**
P = **30** inches
 $L_{M\text{TOTAL PROJECT}}$ = **1324** lbs.

Number of drainage basins / outfalls areas leaving the plan area = **1**

2. Drainage Basin Parameters (This information should be provided for each basin):

Drainage Basin/Outfall Area No. = **1**

Total drainage basin/outfall area = **2.2860** acres
Predevelopment impervious area within drainage basin/outfall area = **0.0000** acres
Post-development impervious area within drainage basin/outfall area = **1.5540** acres
Post-development impervious fraction within drainage basin/outfall area = **0.68**
 $L_{M\text{THIS BASIN}}$ = **1268** lbs.

3. Indicate the proposed BMP Code for this basin.

Proposed BMP = **JF** abbreviation
Removal efficiency = **86** percent

4. Calculate Maximum TSS Load Removed (L_R) for this Drainage Basin by the selected BMP Type.

RG-348 Page 3-33 Equation 3.7:
 $LR = (\text{BMP efficiency}) \times P \times (A_I \times 34.6 + A_P \times 0.54)$

A_C = Total On-Site drainage area in the BMP catchment area
 A_I = Impervious area proposed in the BMP catchment area
 A_P = Pervious area remaining in the BMP catchment area
 L_R = TSS Load removed from this catchment area by the proposed BMP

A_C = **2.286** acres
 A_I = **1.554** acres
 A_P = **0.73** acres
 L_R = **1397** lbs.

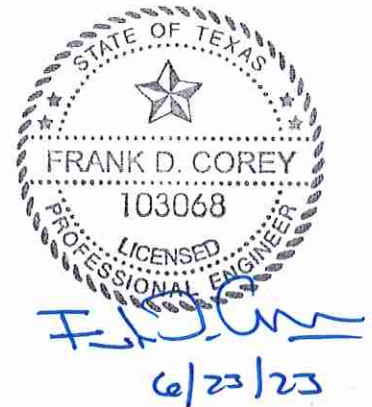

5. Calculate Fraction of Annual Runoff to Treat the drainage basin / outfall area

Desired $L_{M\text{THIS BASIN}}$ = **1324** lbs.
F = **0.95**

6. Calculate Treated Flow required by the BMP Type for this drainage basin / outfall area.

Offsite area draining to BMP = **0.000** acres
Offsite impervious cover draining to BMP = **0.000** acres

Calculations from RG-348
Pages Section 3.2.22

Rainfall Intensity = **1.60** inches per hour
Effective Area = **1.42** acres
Cartridge Length = **54** inches

Peak Treatment Flow Required = **2.29** cubic feet per second

7. Jellyfish

Designed as Required in RG-348
Section 3.2.22

Flow Through Jellyfish Size

Jellyfish Size for Flow-Based Configuration = **JFPD0808-12-3**
Jellyfish Treatment Flow Rate = **2.41** cfs

Texas Commission on Environmental Quality
TSS Removal Calculations

Project Name: **Elsewhere Graden Kitchen & Bar**
Date Prepared: **6/23/2023**

1. The Required Load Reduction for the total project:

Calculations from RG-348
Pages 3-27 to 3-30

Page 3-29 Equation 3.3: $L_M = 27.2(A_N \times P)$

$L_{M \text{ TOTAL PROJECT}}$ = Required TSS removal resulting from the proposed development = 80% of increased load
 A_N = Net increase in impervious area for the project
P = Average annual precipitation, inches

Site Data: Determine Required Load Removal Based on the Entire Project

County =	Bexar	
Total project area included in plan * =	4.324	acres
Predevelopment impervious area within the limits of the plan * =	0.000	acres
Total post-development impervious area within the limits of the plan * =	1.622	acres
Total post-development impervious cover fraction * =	0.38	
P =	30	inches
$L_{M \text{ TOTAL PROJECT}}$ =	1324	lbs.

Number of drainage basins / outfalls areas leaving the plan area = **2**

2. Drainage Basin Parameters (This information should be provided for each basin):

Drainage Basin/Outfall Area No. =	1	
Total drainage basin/outfall area =	0.068	acres
Predevelopment impervious area within drainage basin/outfall area =	0.00	acres
Post-development impervious area within drainage basin/outfall area =	0.068	acres
Post-development impervious fraction within drainage basin/outfall area =	1.00	
$L_{M \text{ THIS BASIN}}$ =	55	lbs.

3. Indicate the proposed BMP Code for this basin.

Proposed BMP =	Untreated	abbreviation
Removal efficiency =	0	percent

6/23/23

INSPECTION, MAINTENANCE, REPAIR, AND RETROFIT PLAN

The attached inspection and maintenance plan outlines the procedures necessary to maintain the performance of the Permanent Best Management Practices for this project.

It is the responsibility of the owner to contract with a representative to provide the inspections and maintenance as outlined in the plan for the duration of the project. The owner will maintain this responsibility until it is assumed or transferred to another entity in writing. If the property is leased or sold, the responsibility for the maintenance will be required to be transferred through the lease agreement, binding covenants, closing documents, or other binding legal instrument.

I, the owner, have read and understand the requirements of the attached Inspection and Maintenance Plan for the proposed Permanent Best Management Practices for my project. I acknowledge that I will maintain responsibility for the implementation and execution of the plan until the responsibility is transferred to or assumed by another party in writing through a binding legal instrument.

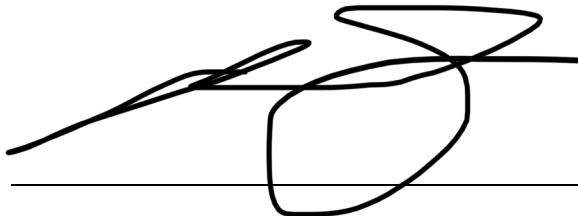

Owner:

5/23/23

Date

Edwards Aquifer Group
Water Pollution Abatement Plan
Permanent Storm Water Section

Attachment G

MAINTENANCE OF JELLYFISH FILTER SYSTEM

As per the latest addendum to TCEQ RG-348 "Complying with the Edward's Aquifer Rules" released on July 2012, the Imbrium Jellyfish has been approved for usage over the Contributing and Recharge Zone. This product has very specific inspection and maintenance procedures that are detailed in the addendum. The engineer of record is not responsible for the specific method to follow while maintaining the product as it is a proprietary device that has been preapproved by TCEQ with specific usage and maintenance procedures. No deviation from the plan that has been approved by TCEQ should be allowed; however, the engineer of record is responsible for putting forth an inspection and maintenance plan for the property owner to use in servicing the device. The maintenance plan below has been spelled out specifically by TCEQ for that purpose, and should be used on this project.

ENGINEER OF RECORD CERTIFICATION



Jellyfish cartridges are passively backwashed automatically after each storm event, which removes accumulated sediment from the membranes and significantly extends the service life of the cartridges and the maintenance interval. If required, the cartridges can be easily manually backwashed without removing the cartridges. Additionally, the lightweight cartridges can be removed by hand and externally rinsed and then reinstalled. These simple maintenance options allow for cartridge regeneration, thereby minimizing cartridge replacement costs and life-cycle treatment costs while ensuring long-term treatment performance.

Regular inspection and maintenance are proven, cost-effective ways to maximize water resource protection for all stormwater pollution control practices are required to insure proper protection for all stormwater pollution control practices and are required to insure proper functionality of the Jellyfish filter. Inspection of the Jellyfish filter is performed from the surface, while proper maintenance requires a combination of procedures conducted from the surface and with worker entry into the structure.

Inspections. Post Construction inspection is required prior to putting the Jellyfish Filter into service. Routine inspections are recommended quarterly during the first year of operation to accurately assess the sediment and floatable pollutant accumulation, and to ensure that the automatic backwash feature is functioning properly. Inspection frequency in subsequent years is based on the maintenance plan developed in the first year, but must occur annually at minimum. Inspections should be conducted immediately after oil, fuel, or other chemical spill.

PILOT-SCALE FIELD TESTING PLAN

The TCEQ Technical Guidance Manual (TGM) was used to design permanent BMP's and measures for this site; therefore pilot-scale field testing is not required.

MEASURES FOR MINIMIZING SURFACE STREAM CONTAMINATION

Contaminated stormwater runoff from the proposed site will enter the water quality devices proposed for this project. Storm water will be filtered and be released at a point consistent with existing hydrology conditions. Therefore, there will be no changes in the way in which water enters a stream as a result of the construction and development.

AGENT AUTHORIZATION FORM

Owner Authorization Form

Texas Commission on Environmental Quality

for Required Signature

Edwards Aquifer Protection Program

Relating to 30 TAC Chapter 213

Effective June 1, 1999

Land Owner Authorization

I, _____ of _____
Land Owner Signatory Name Land Owner Name (Legal Entity or Individual)

am the owner of the property located at

Legal description of the property referenced in the application

and am duly authorized in accordance with §213.4(c)(2) and §213.4(d)(1) or §213.23(c)(2) and §213.23(d) relating to the right to submit an application, signatory authority, and proof of authorized signatory.

I do hereby authorize _____
Applicant Name (Legal Entity or Individual)

to conduct _____
Description of the proposed regulated activities

at _____
Precise location of the authorized regulated activities

Land Owner Acknowledgement

I understand that _____
Land Owner Name (Legal Entity or Individual)

Is ultimately responsible for compliance with the approved or conditionally approved Edwards Aquifer protection plan and any special conditions of the approved plan through all phases of plan implementation even if the responsibility for compliance and the right to possess and control the property referenced in the application has been contractually assumed by another legal entity. I further understand that any failure to comply with any condition of the executive director's approval is a violation is subject to administrative rule or orders and penalties as provided under §213.10 (relating to Enforcement). Such violation may also be subject to civil penalties and injunction.

Land Owner Signature

Jimi Ellis
Land Owner Signature

6/19/23
Date

THE STATE OF § Texas

County of § Bexar

BEFORE ME, the undersigned authority, on this day personally appeared Jimi Ellis known to me to be the person whose name is subscribed to the foregoing instrument, and acknowledged to me that (s)he executed same for the purpose and consideration therein expressed.

GIVEN under my hand and seal of office on this 20th day of June

[Signature]

NOTARY PUBLIC

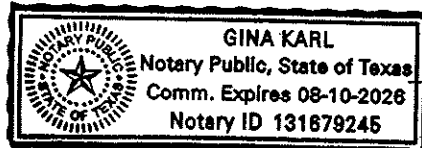

Gina Karl

Typed or Printed Name of Notary

MY COMMISSION EXPIRES: 8-10-2026

Attached: (Mark all that apply)

- Lease Agreement
- Signed Contract
- Deed Recorded Easement
- Other legally binding document

Applicant Acknowledgement

I, Nolan Ellis of
Applicant Signatory Name

Elsewhere Hospitality, LLC
Applicant Name (Legal Entity or Individual)

acknowledge that Ridge East, LLC
Land Owner Name (Legal Entity or Individual)

has provided Elsewhere Hospitality, LLC
Applicant Name (Legal Entity or Individual)

with the right to possess and control the property referenced in the Edwards Aquifer protection plan.

I understand that Elsewhere Hospitality, LLC
Applicant Name (Legal Entity or Individual)

is contractually responsible for compliance with the approved or conditionally approved Edwards Aquifer protection plan and any special conditions of the approved plan through all phases of plan implementation. I further understand that failure to comply with any condition of the executive director's approval is a violation is subject to administrative rule or orders and penalties as provided under §213.10 (relating to Enforcement). Such violation may also be subject to civil penalties and injunction.

Applicant Signature

[Handwritten Signature]
Applicant Signature

6/15/23
Date

THE STATE OF § TX

County of § Bexar

BEFORE ME, the undersigned authority, on this day personally appeared Nolan Ellis known to me to be the person whose name is subscribed to the foregoing instrument, and acknowledged to me that (s)he executed same for the purpose and consideration therein expressed.

GIVEN under my hand and seal of office on this 15th day of June 2023

[Handwritten Signature]
NOTARY PUBLIC

Gabriella Lozano
Typed or Printed Name of Notary

MY COMMISSION EXPIRES: 09/16/2025

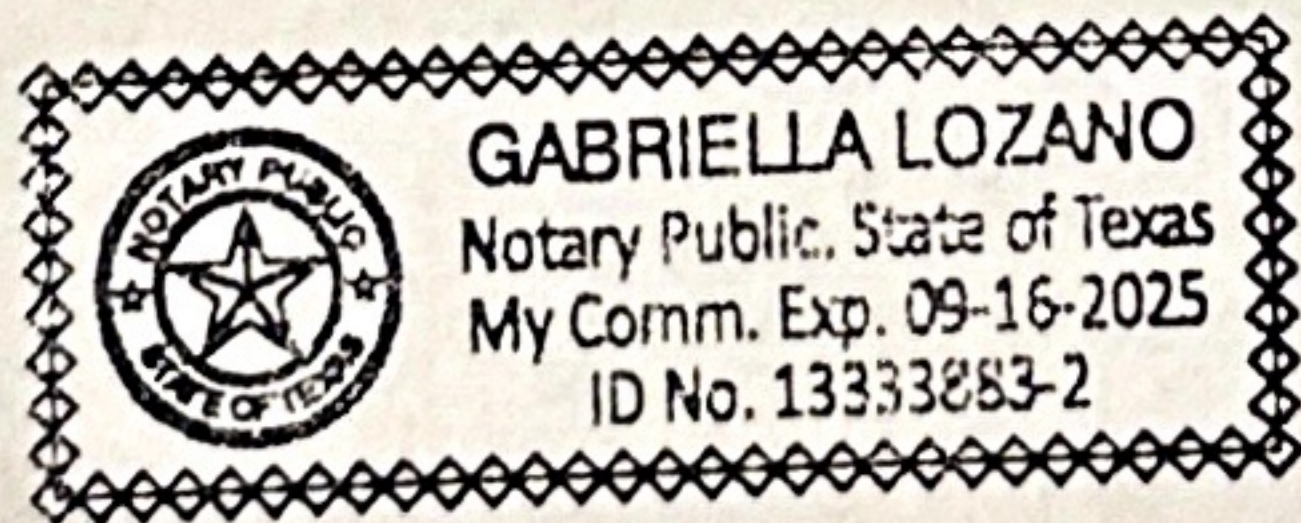

Agent Authorization Form
For Required Signature
Edwards Aquifer Protection Program
Relating to 30 TAC Chapter 213
Effective June 1, 1999

I Nolan Ellis / Terrin Fuhrmann
Print Name

Owner
Title - Owner/President/Other

of Elsewhere Garden Bar & Kitchen
Corporation/Partnership/Entity Name

have authorized Colliers Engineering & Design Representatives
Print Name of Agent/Engineer

of Colliers Engineering & Design
Print Name of Firm/Corporation/Entity

to represent and act on the behalf of the above named Corporation, Partnership, or Entity for the purpose of preparing and submitting this plan application to the Texas Commission on Environmental Quality (TCEQ) for the review and approval consideration of regulated activities.

I also understand that:

1. The applicant is responsible for compliance with 30 Texas Administrative Code Chapter 213 and any condition of the TCEQ's approval letter. The TCEQ is authorized to assess administrative penalties of up to \$10,000 per day per violation.
2. For those submitting an application who are not the property owner, but who have the right to control and possess the property, additional authorization is required from the owner.
3. Application fees are due and payable at the time the application is submitted. The application fee must be sent to the TCEQ cashier or to the appropriate regional office. The application will not be considered until the correct fee is received by the commission.
4. A notarized copy of the Agent Authorization Form must be provided for the person preparing the application, and this form must accompany the completed application.
5. No person shall commence any regulated activity on the Edwards Aquifer Recharge Zone, Contributing Zone or Transition Zone until the appropriate application for the activity has been filed with and approved by the Executive Director.

SIGNATURE PAGE:

[Signature]
Applicant's Signature

5/9/23
Date

THE STATE OF TEXAS §

County of Bexar §

BEFORE ME, the undersigned authority, on this day personally appeared Notan Ellis known to me to be the person whose name is subscribed to the foregoing instrument, and acknowledged to me that (s)he executed same for the purpose and consideration therein expressed.

GIVEN under my hand and seal of office on this 9th day of May, 2023.

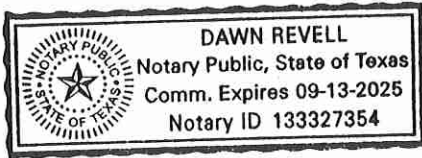

Dawn Revell
NOTARY PUBLIC
Dawn Revell
Typed or Printed Name of Notary

MY COMMISSION EXPIRES: 09-13-2025

Agent Authorization Form
For Required Signature
Edwards Aquifer Protection Program
Relating to 30 TAC Chapter 213
Effective June 1, 1999

I Jimi Ellis,
Print Name

Owner,
Title - Owner/President/Other

of Ridge East, LLC,
Corporation/Partnership/Entity Name

have authorized Colliers Engineering & Design Representatives
Print Name of Agent/Engineer

of Colliers Engineering & Design
Print Name of Firm/Corporation/Entity

to represent and act on the behalf of the above named Corporation, Partnership, or Entity for the purpose of preparing and submitting this plan application to the Texas Commission on Environmental Quality (TCEQ) for the review and approval consideration of regulated activities.

I also understand that:

1. The applicant is responsible for compliance with 30 Texas Administrative Code Chapter 213 and any condition of the TCEQ's approval letter. The TCEQ is authorized to assess administrative penalties of up to \$10,000 per day per violation.
2. For those submitting an application who are not the property owner, but who have the right to control and possess the property, additional authorization is required from the owner.
3. Application fees are due and payable at the time the application is submitted. The application fee must be sent to the TCEQ cashier or to the appropriate regional office. The application will not be considered until the correct fee is received by the commission.
4. A notarized copy of the Agent Authorization Form must be provided for the person preparing the application, and this form must accompany the completed application.
5. No person shall commence any regulated activity on the Edwards Aquifer Recharge Zone, Contributing Zone or Transition Zone until the appropriate application for the activity has been filed with and approved by the Executive Director.

SIGNATURE PAGE:

[Handwritten Signature]
Applicant's Signature

5/9/2023
Date

THE STATE OF TEXAS §

County of Bexar §

BEFORE ME, the undersigned authority, on this day personally appeared _____ known to me to be the person whose name is subscribed to the foregoing instrument, and acknowledged to me that (s)he executed same for the purpose and consideration therein expressed.

GIVEN under my hand and seal of office on this 9th day of May, 2023.

[Handwritten Signature]
NOTARY PUBLIC
Gina Karl
Typed or Printed Name of Notary

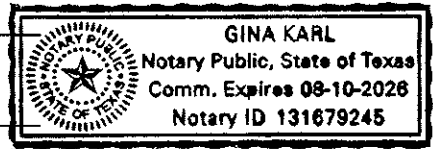

MY COMMISSION EXPIRES: 8-10-2026

CORE DATA FORM



TCEQ Core Data Form

For detailed instructions on completing this form, please read the Core Data Form Instructions or call 512-239-5175.

SECTION I: General Information

1. Reason for Submission (If other is checked please describe in space provided.)		
<input checked="" type="checkbox"/> New Permit, Registration or Authorization (Core Data Form should be submitted with the program application.)		
<input type="checkbox"/> Renewal (Core Data Form should be submitted with the renewal form)	<input type="checkbox"/> Other	
2. Customer Reference Number (if issued)	Follow this link to search for CN or RN numbers in Central Registry**	3. Regulated Entity Reference Number (if issued)
CN		RN

SECTION II: Customer Information

4. General Customer Information		5. Effective Date for Customer Information Updates (mm/dd/yyyy)	
<input checked="" type="checkbox"/> New Customer <input type="checkbox"/> Update to Customer Information <input type="checkbox"/> Change in Regulated Entity Ownership <input type="checkbox"/> Change in Legal Name (Verifiable with the Texas Secretary of State or Texas Comptroller of Public Accounts)			
<i>The Customer Name submitted here may be updated automatically based on what is current and active with the Texas Secretary of State (SOS) or Texas Comptroller of Public Accounts (CPA).</i>			
6. Customer Legal Name (If an individual, print last name first: eg: Doe, John)		<i>If new Customer, enter previous Customer below:</i>	
Elsewhere Hospitality, LLC			
7. TX SOS/CPA Filing Number	8. TX State Tax ID (11 digits)	9. Federal Tax ID (9 digits)	10. DUNS Number (if applicable)
0804986139	32089011400	92-3150678	
11. Type of Customer:	<input type="checkbox"/> Corporation	<input type="checkbox"/> Individual	Partnership: <input type="checkbox"/> General <input checked="" type="checkbox"/> Limited
Government: <input type="checkbox"/> City <input type="checkbox"/> County <input type="checkbox"/> Federal <input type="checkbox"/> Local <input type="checkbox"/> State <input type="checkbox"/> Other	<input type="checkbox"/> Sole Proprietorship		<input type="checkbox"/> Other:
12. Number of Employees		13. Independently Owned and Operated?	
<input checked="" type="checkbox"/> 0-20 <input type="checkbox"/> 21-100 <input type="checkbox"/> 101-250 <input type="checkbox"/> 251-500 <input type="checkbox"/> 501 and higher		<input checked="" type="checkbox"/> Yes <input type="checkbox"/> No	
14. Customer Role (Proposed or Actual) – as it relates to the Regulated Entity listed on this form. Please check one of the following			
<input checked="" type="checkbox"/> Owner <input type="checkbox"/> Operator <input type="checkbox"/> Owner & Operator <input type="checkbox"/> Other: <input type="checkbox"/> Occupational Licensee <input type="checkbox"/> Responsible Party <input type="checkbox"/> VCP/BSA Applicant			
15. Mailing Address:	110 N. Manton Ln.		
	City	State	ZIP
	San Antonio	Tx	78213
			ZIP + 4
16. Country Mailing Information (if outside USA)		17. E-Mail Address (if applicable)	
		terrinfuhrmann@yahoo.com	
18. Telephone Number	19. Extension or Code	20. Fax Number (if applicable)	

SECTION III: Regulated Entity Information**21. General Regulated Entity Information** (If 'New Regulated Entity' is selected, a new permit application is also required.)
 New Regulated Entity Update to Regulated Entity Name Update to Regulated Entity Information

The Regulated Entity Name submitted may be updated, in order to meet TCEQ Core Data Standards (removal of organizational endings such as Inc, LP, or LLC).

22. Regulated Entity Name (Enter name of the site where the regulated action is taking place.)

Elsewhere Garden Bar & Kitchen

23. Street Address of the Regulated Entity:(No PO Boxes)

City	San Anotnio	State	TX	ZIP	78257	ZIP + 4	
-------------	-------------	--------------	----	------------	-------	----------------	--

24. County

Bexar

If no Street Address is provided, fields 25-28 are required.

25. Description to Physical Location:

APPROX 0.53 MILES SW OF N LOOP 1604 W AND NW MILITARY HWY INTERSECTION

26. Nearest City**State****Nearest ZIP Code**

San Antonio

TX

78257

Latitude/Longitude are required and may be added/updated to meet TCEQ Core Data Standards. (Geocoding of the Physical Address may be used to supply coordinates where none have been provided or to gain accuracy).

27. Latitude (N) In Decimal:

29.597722

28. Longitude (W) In Decimal:

-98.572584

Degrees

Minutes

Seconds

Degrees

Minutes

Seconds

29

35

51.7792

-98

34

21.3024

29. Primary SIC Code**30. Secondary SIC Code****31. Primary NAICS Code****32. Secondary NAICS Code**

(4 digits)

(4 digits)

(5 or 6 digits)

(5 or 6 digits)

5812

5813

722410

722513

33. What is the Primary Business of this entity? (Do not repeat the SIC or NAICS description.)

Commercial site: Beer Garden and Kitchen

34. Mailing Address:

Address:

City		State		ZIP		ZIP + 4	
-------------	--	--------------	--	------------	--	----------------	--

35. E-Mail Address:**36. Telephone Number****37. Extension or Code****38. Fax Number** (if applicable)

(210) 393-0511

() -

39. TCEQ Programs and ID Numbers Check all Programs and write in the permits/registration numbers that will be affected by the updates submitted on this form. See the Core Data Form instructions for additional guidance.

<input type="checkbox"/> Dam Safety	<input type="checkbox"/> Districts	<input checked="" type="checkbox"/> Edwards Aquifer	<input type="checkbox"/> Emissions Inventory Air	<input type="checkbox"/> Industrial Hazardous Waste
<input type="checkbox"/> Municipal Solid Waste	<input type="checkbox"/> New Source Review Air	<input type="checkbox"/> OSSF	<input type="checkbox"/> Petroleum Storage Tank	<input type="checkbox"/> PWS
<input type="checkbox"/> Sludge	<input type="checkbox"/> Storm Water	<input type="checkbox"/> Title V Air	<input type="checkbox"/> Tires	<input type="checkbox"/> Used Oil
<input type="checkbox"/> Voluntary Cleanup	<input type="checkbox"/> Wastewater	<input type="checkbox"/> Wastewater Agriculture	<input type="checkbox"/> Water Rights	<input type="checkbox"/> Other:

SECTION IV: Preparer Information

40. Name:	Frank D. Corey, PE	41. Title:	Senior Project Manager
42. Telephone Number	43. Ext./Code	44. Fax Number	45. E-Mail Address
(726) 223-4992		() -	frank.corey@collierseng.com

SECTION V: Authorized Signature

46. By my signature below, I certify, to the best of my knowledge, that the information provided in this form is true and complete, and that I have signature authority to submit this form on behalf of the entity specified in Section II, Field 6 and/or as required for the updates to the ID numbers identified in field 39.

Company:	Elsewhere hospitality llc	Job Title:	Owner
Name (In Print):	Terrin Fuhrmann	Phone:	(210) 393- 0511
Signature:		Date:	6-13-23

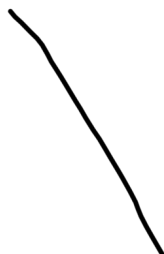

APPLICATION FEE FORM

Application Fee Form

Texas Commission on Environmental Quality

Name of Proposed Regulated Entity: Elsewhere Garden Bar & Kitchen

Regulated Entity Location: North of Loop 1604 between Lockhill Selma & NW Military Highway,
San Antonio, Texas

Name of Customer: Terrin Fuhrmann

Contact Person: Frank D. Corey, PE

Phone: 726-223-4992

Customer Reference Number (if issued): CN _____

Regulated Entity Reference Number (if issued): RN _____

Austin Regional Office (3373)

Hays

Travis

Williamson

San Antonio Regional Office (3362)

Bexar

Medina

Uvalde

Comal

Kinney

Application fees must be paid by check, certified check, or money order, payable to the **Texas Commission on Environmental Quality**. Your canceled check will serve as your receipt. **This form must be submitted with your fee payment.** This payment is being submitted to:

Austin Regional Office

San Antonio Regional Office

Mailed to: TCEQ - Cashier

Overnight Delivery to: TCEQ - Cashier

Revenues Section

12100 Park 35 Circle

Mail Code 214

Building A, 3rd Floor

P.O. Box 13088

Austin, TX 78753

Austin, TX 78711-3088

(512)239-0357

Site Location (Check All That Apply):

Recharge Zone

Contributing Zone

Transition Zone

Type of Plan	Size	Fee Due
Water Pollution Abatement Plan, Contributing Zone Plan: One Single Family Residential Dwelling	Acres	\$
Water Pollution Abatement Plan, Contributing Zone Plan: Multiple Single Family Residential and Parks	Acres	\$
Water Pollution Abatement Plan, Contributing Zone Plan: Non-residential	4.32 Acres	\$ 4,000
Sewage Collection System	L.F.	\$
Lift Stations without sewer lines	Acres	\$
Underground or Aboveground Storage Tank Facility	Tanks	\$
Piping System(s)(only)	Each	\$
Exception	Each	\$
Extension of Time	Each	\$

Signature: _____

Date: 5/9/23

Application Fee Schedule

Texas Commission on Environmental Quality

Edwards Aquifer Protection Program 30 TAC Chapter 213 (effective 05/01/2008)

Water Pollution Abatement Plans and Modifications

Contributing Zone Plans and Modifications

<i>Project</i>	<i>Project Area in Acres</i>	<i>Fee</i>
One Single Family Residential Dwelling	< 5	\$650
Multiple Single Family Residential and Parks	< 5	\$1,500
	5 < 10	\$3,000
	10 < 40	\$4,000
	40 < 100	\$6,500
	100 < 500	\$8,000
Non-residential (Commercial, industrial, institutional, multi-family residential, schools, and other sites where regulated activities will occur)	≥ 500	\$10,000
	< 1	\$3,000
	1 < 5	\$4,000
	5 < 10	\$5,000
	10 < 40	\$6,500
	40 < 100	\$8,000
	≥ 100	\$10,000

Organized Sewage Collection Systems and Modifications

<i>Project</i>	<i>Cost per Linear Foot</i>	<i>Minimum Fee- Maximum Fee</i>
Sewage Collection Systems	\$0.50	\$650 - \$6,500

Underground and Aboveground Storage Tank System Facility Plans and Modifications

<i>Project</i>	<i>Cost per Tank or Piping System</i>	<i>Minimum Fee- Maximum Fee</i>
Underground and Aboveground Storage Tank Facility	\$650	\$650 - \$6,500

Exception Requests

<i>Project</i>	<i>Fee</i>
Exception Request	\$500

Extension of Time Requests

<i>Project</i>	<i>Fee</i>
Extension of Time Request	\$150

EXHIBIT 1-

WPAP SITE PLAN & DETAILS

- A written notice of construction must be submitted to the TCEQ regional office at least 48 hours prior to the start of any regulated activities. This notice must include:
 - the name of the approved project;
 - the activity start date; and
 - the contact information of the prime contractor.
- All contractors conducting regulated activities associated with this project must be provided with complete copies of the approved Water Pollution Abatement Plan (WPAP) and the TCEQ letter indicating the specific conditions of its approval. During the course of these regulated activities, the contractors are required to keep on-site copies of the approved plan and approval letter.
- If any sensitive feature(s) (caves, solution cavity, sink hole, etc.) is discovered during construction, all regulated activities near the sensitive feature must be suspended immediately. The appropriate TCEQ regional office must be immediately notified of any sensitive features encountered during construction. Construction activities may not be resumed until the TCEQ has reviewed and approved the appropriate protective measures in order to protect any sensitive features and the Edwards Aquifer from potentially adverse impacts to water quality.
- No temporary or permanent hazardous substance storage tank shall be installed within 150 feet of a water supply source, distribution system, well, or sensitive feature.
- Prior to beginning any construction activity, all temporary erosion and sedimentation (E&S) control measures must be properly installed and maintained in accordance with the approved plans and manufacturers specifications. If inspections indicate a control has been used inappropriately or incorrectly, the applicant must replace or modify the control for site situations. These controls must remain in place until the disturbed areas have been permanently stabilized.
- Any sediment that escapes the construction site must be collected and properly disposed of before the next rain event to ensure it is not washed into surface streams, sensitive features, etc.
- Sediment must be removed from the sediment traps or sedimentation basins not later than when it occupies 50% of the basin's design capacity.
- Litter, construction debris, and construction chemicals exposed to stormwater shall be prevented from being discharged offsite.
- All spoils (excavated material) generated from the project site must be stored on-site with proper E&S controls. For storage or disposal of spoils at another site on the Edwards Aquifer Recharge Zone, the owner of the site must receive approval of a water pollution abatement plan for the placement of fill material or mass grading prior to the placement of spoils at the other site.
- If portions of the site will have a temporary or permanent cease in construction activity lasting longer than 14 days, soil stabilization in those areas shall be initiated as soon as possible prior to the 14th day of inactivity. If activity will resume prior to the 21st day, stabilization measures are not required. If drought conditions or inclement weather prevent action by the 14th day, stabilization measures shall be initiated as soon as possible.
- The following records shall be maintained and made available to the TCEQ upon request:
 - the dates when major grading activities occur;
 - the dates when construction activities temporarily or permanently cease on a portion of the site; and
 - the dates when stabilization measures are initiated.
- The holder of any approved Edwards Aquifer protection plan must notify the appropriate regional office in writing and obtain approval from the executive director prior to initiating any of the following:
 - A. any physical or operational modification of any water pollution abatement structure(s), including but not limited to ponds, dams, berms, sewage treatment plants, and diversionary structures;
 - B. any change in the nature or character of the regulated activity from that which was originally approved or a change which would significantly impact the ability of the plan to prevent pollution of the Edwards Aquifer;
 - C. any development of land previously identified as undeveloped in the original water pollution abatement plan.

Austin Regional Office
14200 Park 35 Circle, Building A
Austin, Texas 78753-1808
Phone (512) 339-2929
Fax (512) 339-3795

San Antonio Regional Office
14250 Judson Road
San Antonio, Texas 78233-4480
Phone (210) 490-3096
Fax (210) 545-4329

SWSP MODIFICATIONS		
DATE	SIGNATURE	DESCRIPTION

THIS SHEET HAS BEEN PREPARED FOR PURPOSES OF THE SWP3 ONLY. ALL OTHER CIVIL ENGINEERING RELATED INFORMATION SHOULD BE ACQUIRED FROM THE APPROPRIATE SHEET IN THE CIVIL IMPROVEMENT PLANS.

THE ENGINEERING SEAL HAS BEEN AFFIXED TO THIS SHEET ONLY FOR THE PURPOSE OF DEMONSTRATING COMPLIANCE WITH THE TPDES-STORM WATER POLLUTION PREVENTION PLAN (SWP3) REGULATIONS.

GENERAL NOTES:

- THIS EXHIBIT IS TO BE USED FOR THE PURPOSES OF STORMWATER POLLUTION PREVENTION ONLY. ALL OTHER CIVIL ENGINEERING INFORMATION SHOULD BE OBTAINED FROM THE APPROPRIATE CONSTRUCTION DOCUMENTS.
- THE PURPOSE OF THE SIGNATURE AND SEAL OF THE ENGINEER ON THIS DOCUMENT IS TO DEMONSTRATE COMPLIANCE WITH THE TPDES STORM WATER POLLUTION PREVENTION PLAN REGULATIONS ONLY.
- ALL OWNERS/OPERATORS ARE RESPONSIBLE FOR FAMILIARIZING THEMSELVES WITH THE STORMWATER POLLUTION PREVENTION PLAN AND COMPLYING WITH THE REGULATIONS CONTAINED WITHIN IT.

INSTALLATION:

- CONTRACTOR TO ENSURE THAT STRUCTURAL BMP'S ARE INSTALLED WITHIN THE LIMITS OF THE SITE BOUNDARY.
- CONTRACTOR MAY INSTALL THE BEST MANAGEMENT PRACTICES IN PHASES THAT COINCIDE WITH THE DISTURBANCE OF UPGRADIENT AREA. THIS PHASING SHOULD BE NOTED WITHIN THE MODIFICATIONS SECTION WITH THE SIGNATURE AND DATE OF THE RESPONSIBLE PARTY.

MAINTENANCE AND INSPECTION:

- CONTRACTOR SHOULD LIMIT CONSTRUCTION ACTIVITIES TO ONLY THOSE AREAS SHOWN TO BE DISTURBED ON THIS PLAN. IF ADDITIONAL VEGETATED AREAS ARE DISTURBED, THEY SHOULD BE PROTECTED WITH APPROPRIATE BEST MANAGEMENT PRACTICES UNTIL THE AREAS HAVE BEEN STABILIZED. THE AREAS OF THIS ADDITIONAL SOIL DISTURBANCE, AND THE MEASURES USED SHOULD BE SHOWN ON THE SITE PLAN AND NOTED WITHIN THE MODIFICATIONS SECTION WITH THE SIGNATURE AND DATE OF THE RESPONSIBLE PARTY.
- CONTRACTOR IS RESPONSIBLE FOR MAINTENANCE AND INSPECTION OF BMP'S. THE CONTRACTOR MAY MODIFY THE CONTROLS AS NECESSARY TO PREVENT SEDIMENT RUNOFF. THESE MODIFICATIONS SHOULD BE SHOWN IN THE SITE PLAN AND NOTED WITHIN THE MODIFICATIONS SECTION WITH THE SIGNATURE AND DATE OF THE RESPONSIBLE PARTY.
- LOCATION OF CONSTRUCTION ENTRANCE/EXIT, CONCRETE WASHOUT PIT, AND EQUIPMENT AND STORAGE AREA ARE TO BE FIELD DETERMINED. LOCATIONS SHALL BE UPDATED ON THIS PLAN.

PROJECT COMPLETION:

- ALL DISTURBED AREAS THAT ARE NOT COVERED BY IMPERVIOUS COVER ARE TO BE STABILIZED PRIOR TO REMOVAL OF ANY BMP'S.
- BEST MANAGEMENT PRACTICES MAY BE REMOVED IN PHASES IF ALL UPGRADIENT AREA HAVE BEEN STABILIZED. THIS PHASING SHOULD BE NOTED WITHIN THE MODIFICATIONS SECTION WITH THE SIGNATURE AND DATE OF THE RESPONSIBLE PARTY.

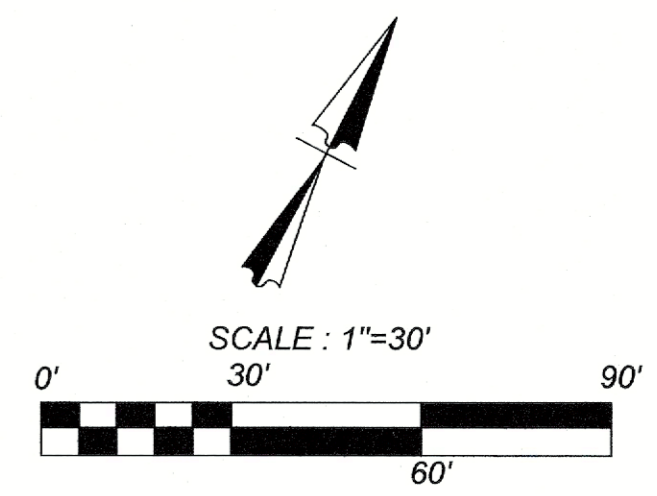
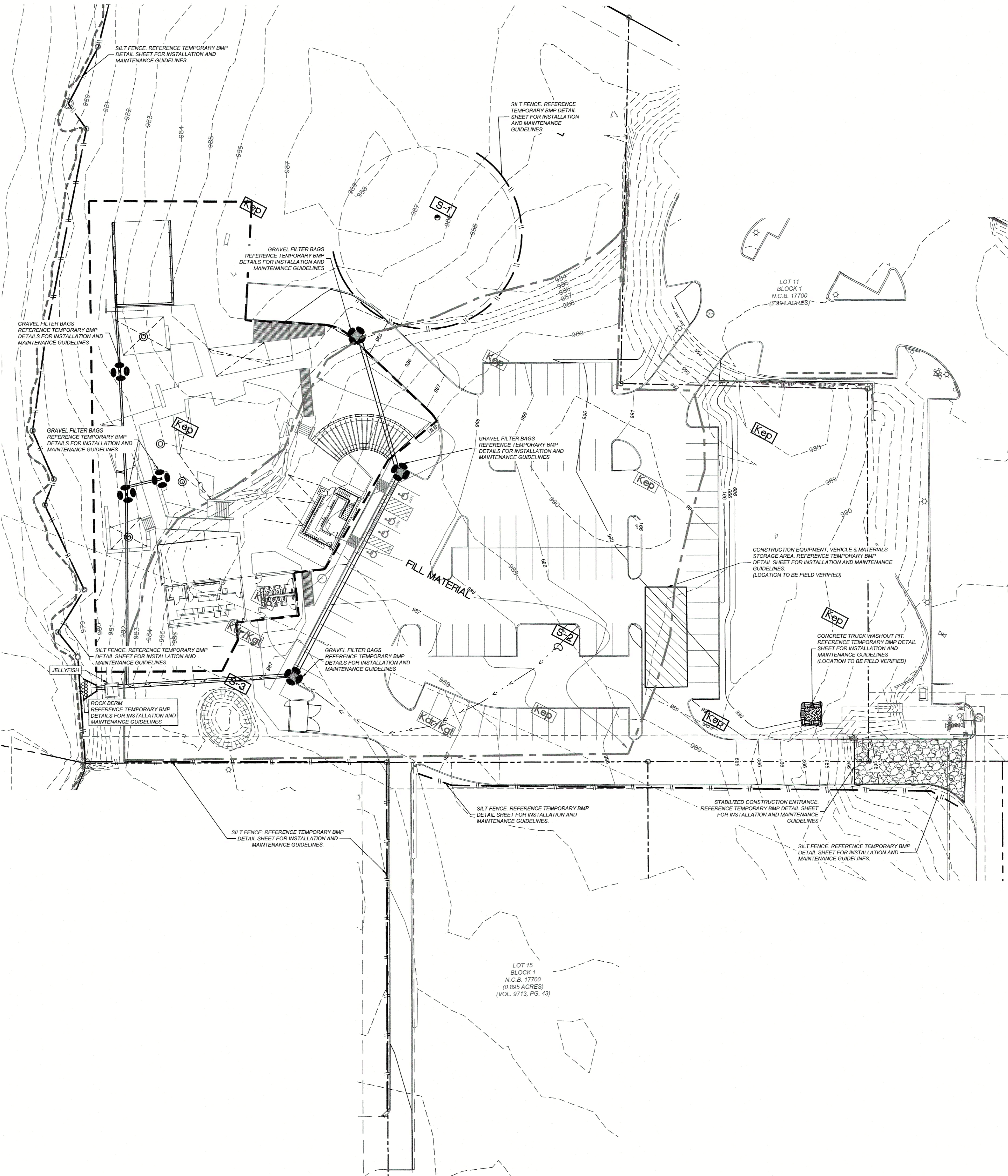

LEGEND

PROPERTY LINE: - - - - -

EXISTING CONTOUR: - - - - -

PROPOSED CONTOUR (BY OTHERS): - - - - -

SILT FENCE: || - - - - ||

CONSTRUCTION EQUIPMENT, VEHICLE, AND MATERIALS STORAGE AREA: [Hatched Box]

FLOW ARROW: →

STABILIZED CONSTRUCTION ENTRANCE / EXIT: [Stippled Box]

CONCRETE WASHOUT PIT: [Square with Diagonal Lines]

ALLUVIUM: [Box with 'Qal']

BUDA LIMESTONE: [Box with 'Kbu']

DEL RIO CLAY: [Box with 'Kdr']

GEORGETOWN FORMATION: [Box with 'Kgt']

PERSON FORMATION: [Box with 'Kep']

KAINER FORMATION: [Box with 'Kek']

GLEN ROSE FORMATION: [Box with 'Kgru']

POTENTIAL RECHARGE FEATURE: [Box with 'S-1']

FAULT, LOCATED APPROXIMATELY (DOWNTHROWN SIDE, U.PHTHROWN SIDE): - - - - -

POSSIBLE FAULT (AS LOCATED BY AERIAL PHOTOGRAPHS): - - - - -

NON-KARST CLOSED DEPRESSION: [Circle with Dashed Line]

PROJECT COMPLETION:

- ALL DISTURBED AREAS ARE NOT COVERED BY IMPERVIOUS COVER ARE TO BE STABILIZED PER THE SWPPP AND PROJECT SPECIFICATIONS PRIOR TO REMOVAL OF ANY BMP'S AND/OR PRIOR TO FILING A NOTICE OF TERMINATION (NOT).
- BEST MANAGEMENT PRACTICES MAY BE REMOVED IN PHASES IF ALL UPGRADIENT AREAS HAVE BEEN STABILIZED PER SWPPP AND PROJECT SPECIFICATIONS. THIS PHASING SHOULD BE NOTED WITHIN THE MODIFICATIONS SECTION WITH THE SIGNATURE AND DATE OF THE RESPONSIBLE PARTY.
- CONTRACTOR TO ENSURE THEY HAVE MET ALL REQUIREMENTS OF THE SWPPP BEFORE FILING A NOTICE OF TERMINATION (NOT).

GENERAL:

- THIS EXHIBIT IS TO BE USED FOR THE PURPOSES OF STORMWATER POLLUTION PREVENTION ONLY. ALL OTHER CIVIL ENGINEERING INFORMATION SHOULD BE OBTAINED FROM THE APPROPRIATE CONSTRUCTION DOCUMENTS.
- THE PURPOSE OF THE SIGNATURE AND SEAL OF THE ENGINEER ON THIS DOCUMENT IS TO DEMONSTRATE COMPLIANCE WITH THE TPDES STORMWATER POLLUTION PREVENTION PLAN REGULATIONS ONLY.
- ALL OWNERS/OPERATORS ARE RESPONSIBLE FOR FAMILIARIZING THEMSELVES WITH THE STORMWATER POLLUTION PREVENTION PLAN AND COMPLYING WITH THE REGULATIONS CONTAINED WITHIN IT.
- CPS IS A SECONDARY OPERATOR IN THIS PROJECT. THEY WILL BE INSTALLING THE GAS AND ELECTRIC UTILITIES.

NOTES:

- CONTRACTOR SHALL IMMEDIATELY NOTIFY THE ENGINEER OF ANY QUESTIONS THAT MAY ARISE CONCERNING THE INTENT, PLACEMENT, OR LIMITS OF DIMENSIONS NECESSARY FOR CONSTRUCTION OF THIS PROJECT.
- THE CONTRACTOR SHALL PRESERVE ALL CONSTRUCTION STAKES, MARKS, ETC. IF ANY ARE DESTROYED OR REMOVED BY THE CONTRACTOR OR HIS EMPLOYEES, THEY SHALL BE REPLACED AT THE CONTRACTOR'S EXPENSE.
- CONTRACTOR SHALL BE RESPONSIBLE FOR RESTORING TO ITS ORIGINAL OR BETTER CONDITION ANY DAMAGE DONE TO EXISTING UTILITIES, FENCES, PAVEMENT, CURBS, DRIVEWAYS, OR SIDEWALKS (NO SEPARATE PAY ITEM).
- CONTRACTOR SHALL BE RESPONSIBLE FOR COORDINATING WITH ALL NECESSARY UTILITY COMPANIES FOR PROVIDING TEMPORARY SERVICES DURING CONSTRUCTION.
- ALL DIMENSIONS MUST BE VERIFIED ON THE JOB AND THE ENGINEER MUST BE NOTIFIED OF ANY DISCREPANCIES BEFORE PROCEEDING WITH CONSTRUCTION.
- THE CONTRACTOR SHALL SAW CUT EXISTING PAVEMENT, CURBS, AND SIDEWALKS AT NEW PAVEMENT, CURBS, AND SIDEWALK JUNCTURES. NO JAGGED OR IRREGULAR CUTS WILL BE ALLOWED OR ACCEPTED.

Date: Jun 23, 2023, 11:58am User: D: SIlveira
File: K:\1082\01\02 Design\Civil\WPAP\WPAP Site Plan.dwg

K&E
ENGINEERS + SURVEYING
has joined Cores Engineering & Design, Inc.
Phone #: (512) 878-8444 • Fax #: (512) 878-8441
TBE Firm #: 0519 • TBE Firm #: 10122300

ISSUE DATE
REVISIONS

STATE OF TEXAS
FRANK D. COPEL
103068
Professional Engineer
6/23/23

ELSEWHERE GARDEN BAR & KITCHEN
WATER POLLUTION ABATEMENT PLAN
WPAP SITE PLAN

JOB NO.:
DATE:
DRAWN: - CHECKED: -
SHEET NUMBER:

EX-1

EXHIBIT 2-

WATER QUALITY PLAN & DETAILS

EXISTING UTILITY NOTE:
 THE CONTRACTOR SHALL BE REQUIRED TO LOCATE ALL PUBLIC OR PRIVATE UTILITIES INCLUDING BUT NOT LIMITED TO WATER, SEWER, TELEPHONE AND FIBER OPTIC LINES, SITE LIGHTING ELECTRIC, SECONDARY ELECTRIC, PRIMARY ELECTRICAL DUCTBANKS, LANDSCAPE IRRIGATION FACILITIES, AND GAS LINES. ANY UTILITY CONFLICTS THAT ARISE SHOULD BE COMMUNICATED TO THE ENGINEER IMMEDIATELY AND PRIOR TO CONSTRUCTION. THE CONTRACTOR SHALL CONTACT 1-800-DIG-TESS A MINIMUM OF 48 HOURS PRIOR TO THE START OF CONSTRUCTION. ANY DAMAGE TO EXISTING UTILITIES SHALL BE THE SOLE RESPONSIBILITY OF THE CONTRACTOR AND THE REPAIR SHALL BE AT CONTRACTOR'S SOLE EXPENSE WHETHER THE UTILITY IS SHOWN ON THESE PLANS OR NOT.

TRENCH EXCAVATION SAFETY PROTECTION NOTE:
 CONTRACTOR AND/OR CONTRACTOR'S INDEPENDENTLY RETAINED EMPLOYEE OR STRUCTURAL DESIGN / GEOTECHNICAL / SAFETY / EQUIPMENT CONSULTANT, IF ANY, SHALL REVIEW THESE PLANS AND ANY AVAILABLE GEOTECHNICAL INFORMATION AND THE ANTICIPATED INSTALLATION SITES WITHIN THE PROJECT WORK AREA IN ORDER TO IMPLEMENT CONTRACTOR'S TRENCH EXCAVATION SAFETY PROTECTION SYSTEMS, PROGRAMS AND/OR PROCEDURES FOR THE PROJECT DESCRIBED IN THE CONTRACT DOCUMENTS. THE CONTRACTOR'S IMPLEMENTATION OF THESE SYSTEMS, PROGRAMS AND/OR PROCEDURES SHALL PROVIDE FOR ADEQUATE TRENCH EXCAVATION SAFETY PROTECTION THAT COMPLY WITH AS A MINIMUM, OSHA STANDARDS FOR TRENCH EXCAVATIONS. SPECIFICALLY, CONTRACTOR AND/OR CONTRACTOR'S INDEPENDENTLY RETAINED EMPLOYEE OR SAFETY CONSULTANT SHALL IMPLEMENT A TRENCH SAFETY PROGRAM IN ACCORDANCE WITH OSHA STANDARDS GOVERNING THE PRESENCE AND ACTIVITIES OF INDIVIDUALS WORKING IN AND AROUND TRENCH EXCAVATION.

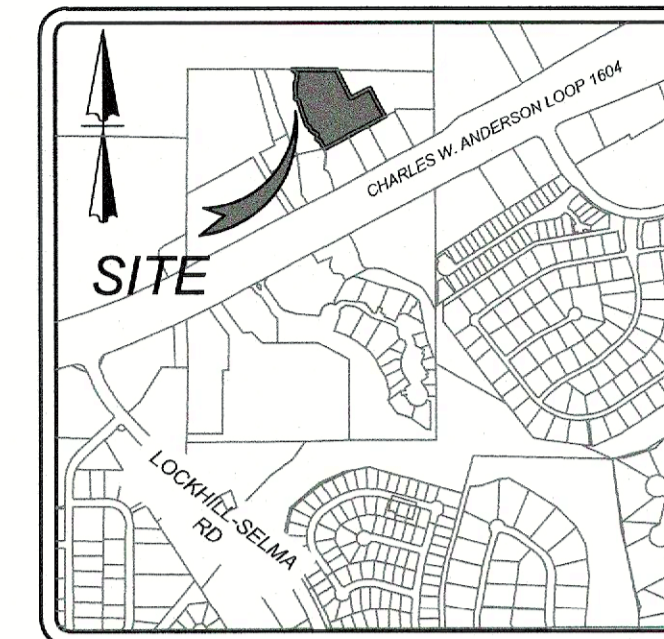
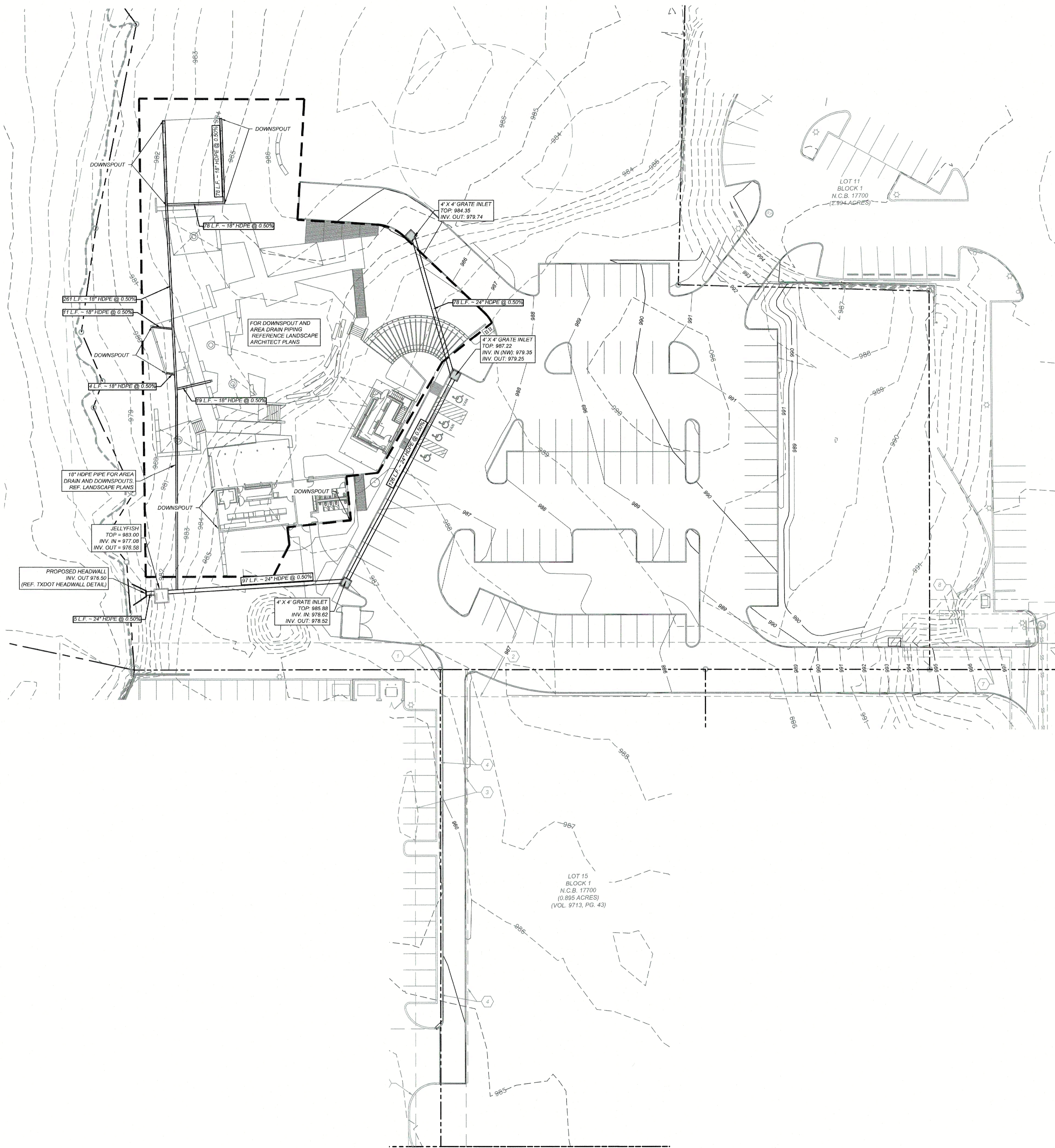

LOCATION MAP
N.T.S.

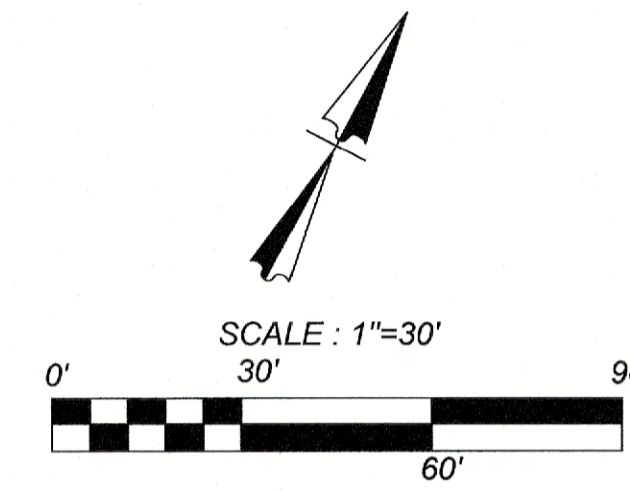

LEGEND	
PROPERTY LINE	---
EXISTING CONTOUR	- - - - -
PROPOSED CONTOUR	_____
PROPOSED STORM DRAIN	====
PROPOSED DRAINAGE STRUCTURE	■
UTILITY CROSSING	⊗

KFW
ENGINEERS + SURVEYING
 3427 Panhandle Hwy, Suite 200, San Antonio, TX 78231
 Phone #: (210) 979-9444 • Fax #: (210) 979-9441
 TBP# Perm #: 5215 • TBP#S Perm #: 1012200

ISSUE DATE: _____
 REVISIONS: _____

 6/23/22

ELSEWHERE GARDEN BAR & KITCHEN
LOOP 1604, SAN ANTONIO, TEXAS
WATER QUALITY PLAN & DETAILS SHEET 1 OF 2

JOB NO: 1082-01-02
 DATE: DECEMBER 2022
 DRAWN: SR CHECKED: FC
 SHEET NUMBER:
EX-2

Date: Jun 22, 2023, 3:36pm User ID: SRivera
 File: K:\1082\01\02\Design\Civil\05.1 (STORM DRAIN PLAN 10820102).dwg

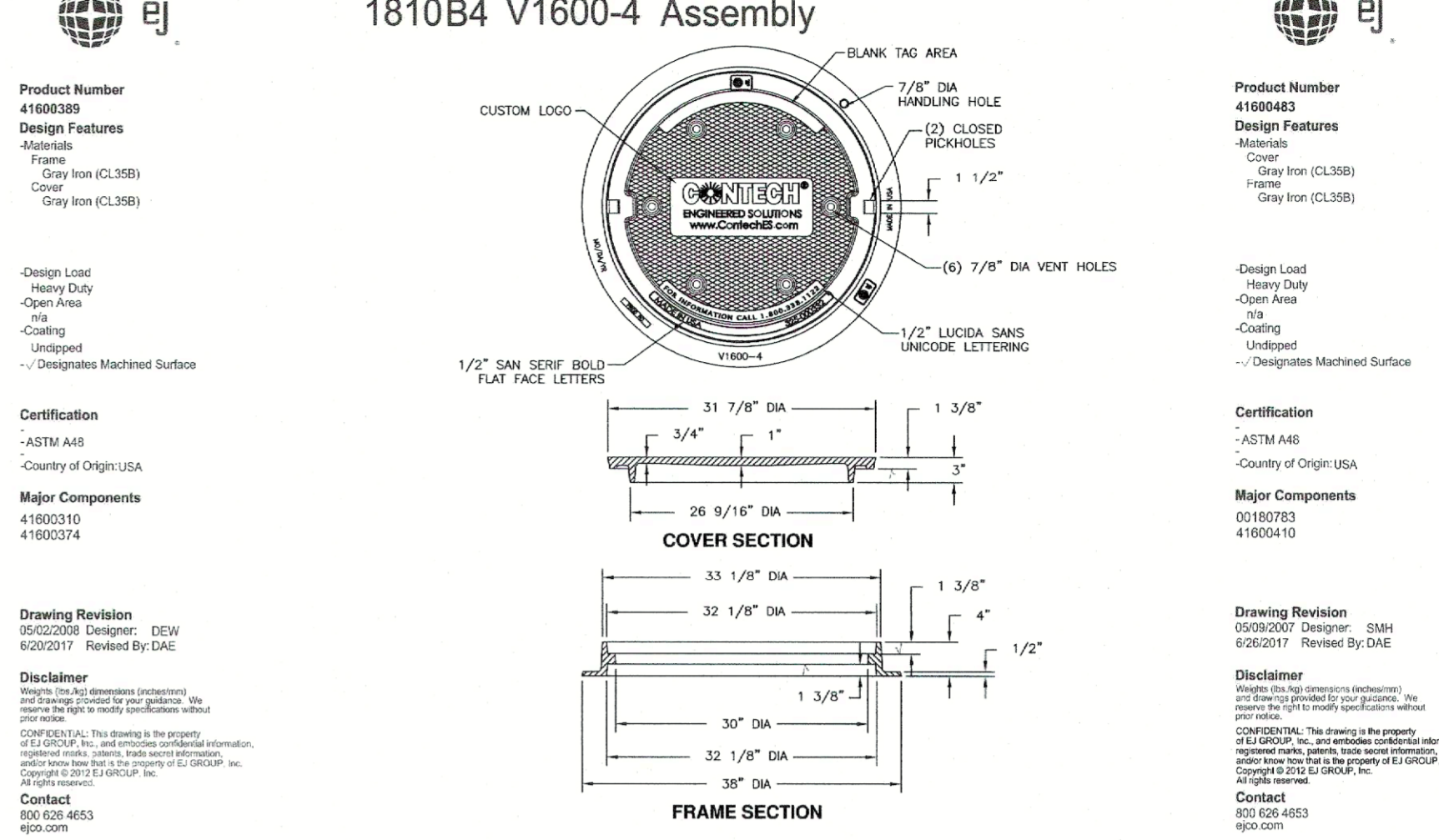
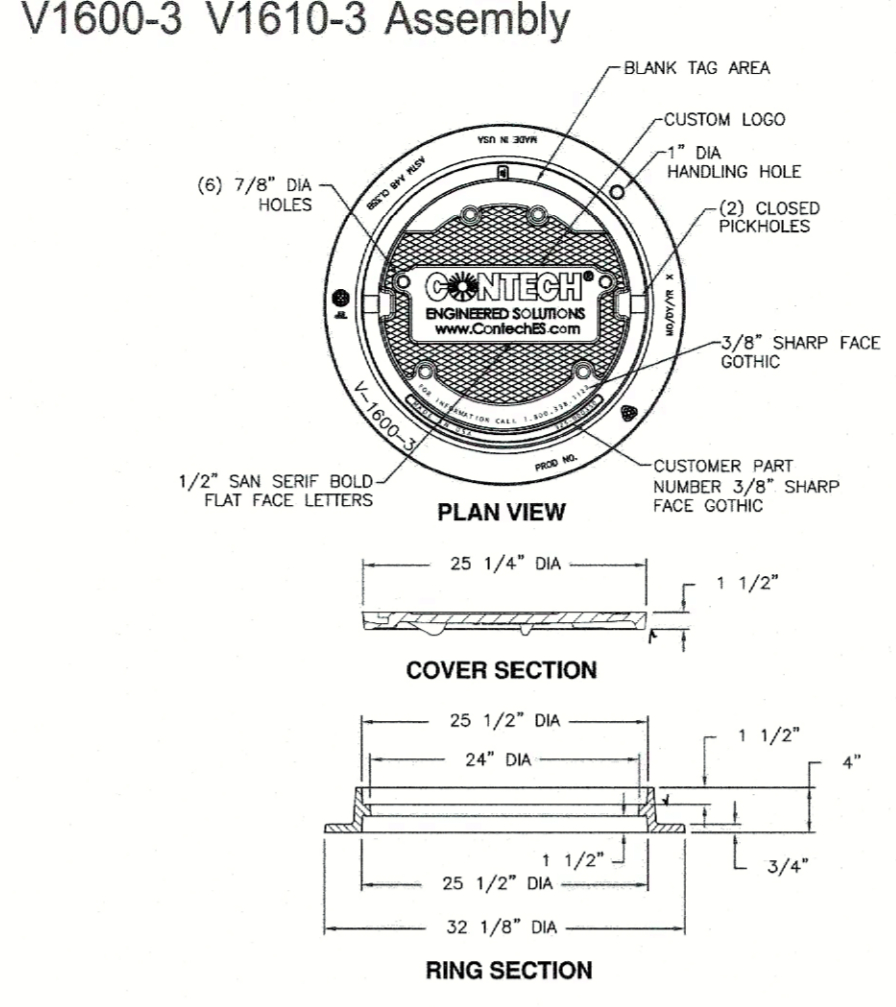
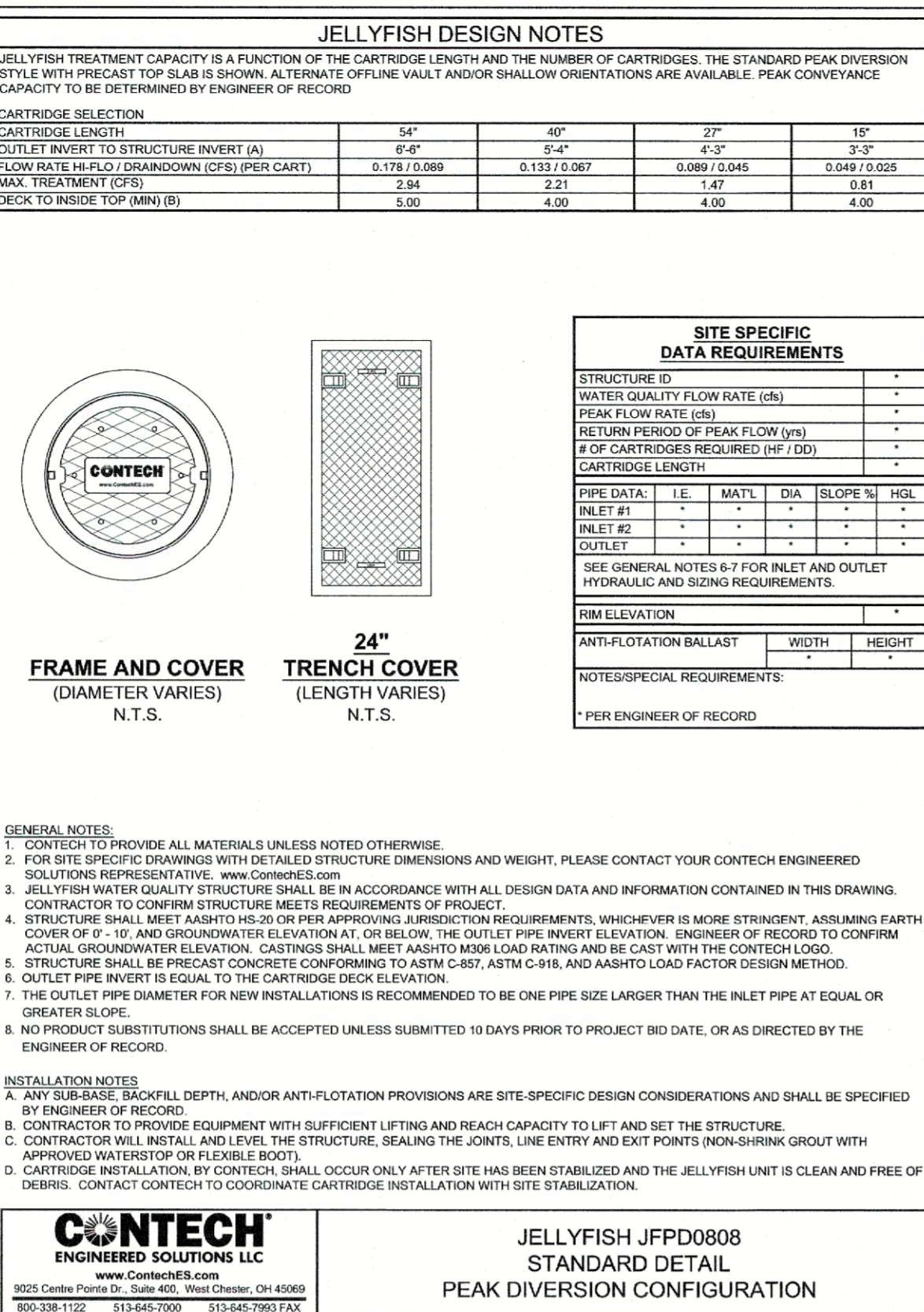
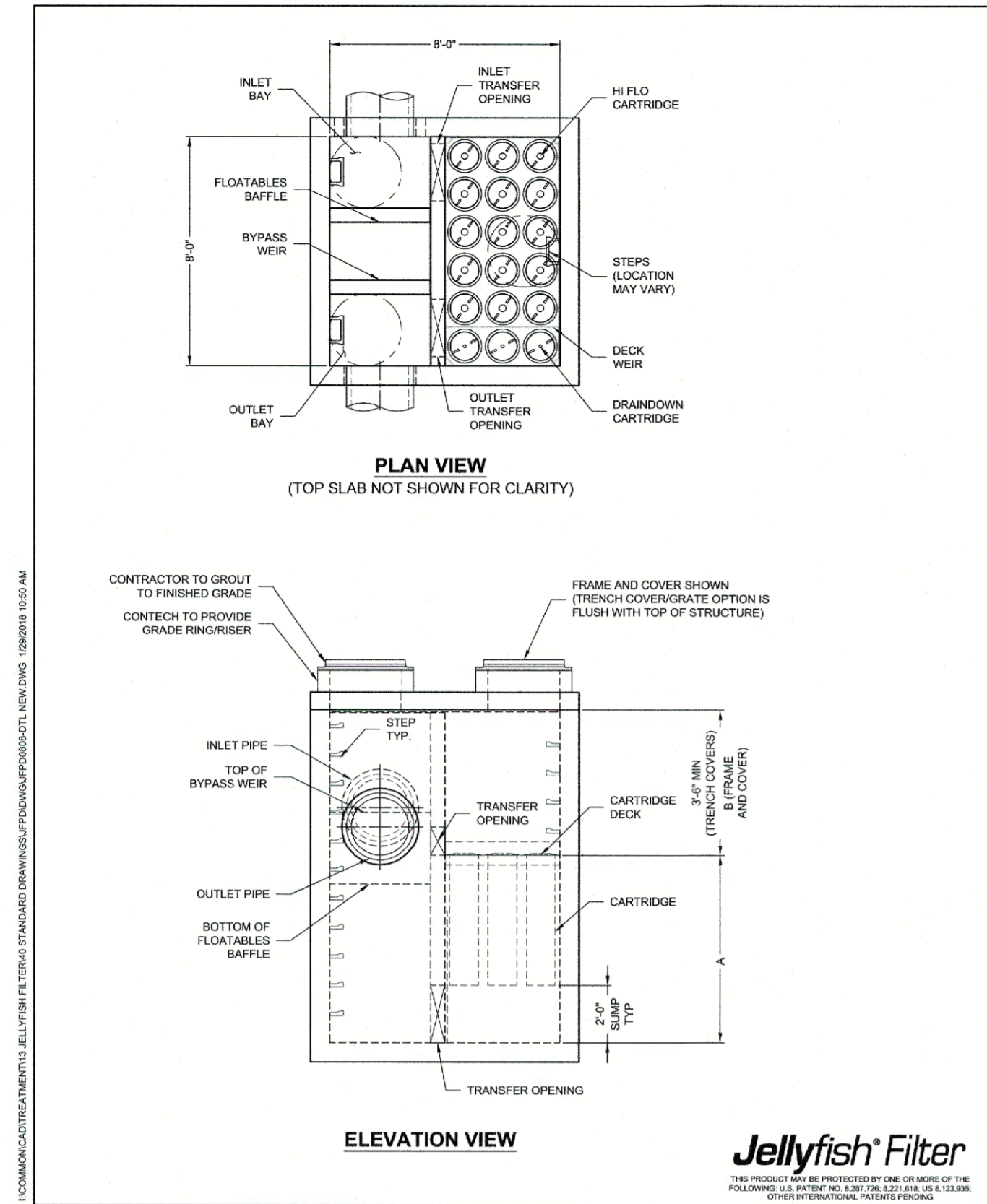

TABLE OF VARIABLE DIMENSIONS AND QUANTITIES FOR ONE HEADWALL

CL. (ft)	W (ft)	H (ft)	L (ft)	Rein. (ft)	Rein. (ft)	Rein. (ft)	Rein. (ft)	Rein. (ft)	Rein. (ft)
12'	4'-2 1/2"	2'-4"	2'-10"	3'-3 1/4"	84	0.6	1'-9"	20	0.2
15'	5'-3 1/2"	2'-8 1/2"	3'-10"	4'-5 1/2"	120	0.9	2'-8"	32	0.3
18'	6'-4 1/2"	3'-1"	5'-10"	6'-5 1/2"	160	1.2	3'-6"	48	0.4
21'	7'-5 1/2"	3'-6 1/2"	8'-10"	9'-5 1/2"	210	1.5	4'-4"	64	0.5
24'	8'-6 1/2"	4'-1"	11'-10"	12'-5 1/2"	270	1.8	5'-2"	80	0.6
27'	9'-7 1/2"	4'-6 1/2"	14'-10"	15'-5 1/2"	330	2.1	6'-0"	96	0.7
30'	10'-8 1/2"	5'-1"	17'-10"	18'-5 1/2"	390	2.4	6'-8"	112	0.8
33'	11'-9 1/2"	5'-6 1/2"	20'-10"	21'-5 1/2"	450	2.7	7'-6"	128	0.9
36'	13'-0 1/2"	6'-1"	23'-10"	24'-5 1/2"	510	3.0	8'-4"	144	1.0
39'	14'-1 1/2"	6'-6 1/2"	26'-10"	27'-5 1/2"	570	3.3	9'-2"	160	1.1
42'	15'-2 1/2"	7'-1"	29'-10"	30'-5 1/2"	630	3.6	10'-0"	176	1.2
45'	16'-3 1/2"	7'-6 1/2"	32'-10"	33'-5 1/2"	690	3.9	10'-8"	192	1.3
48'	17'-4 1/2"	8'-1"	35'-10"	36'-5 1/2"	750	4.2	11'-6"	208	1.4
51'	18'-5 1/2"	8'-6 1/2"	38'-10"	39'-5 1/2"	810	4.5	12'-4"	224	1.5
54'	19'-6 1/2"	9'-1"	41'-10"	42'-5 1/2"	870	4.8	13'-2"	240	1.6
57'	20'-7 1/2"	9'-6 1/2"	44'-10"	45'-5 1/2"	930	5.1	14'-0"	256	1.7
60'	21'-8 1/2"	10'-1"	47'-10"	48'-5 1/2"	990	5.4	14'-8"	272	1.8
63'	22'-9 1/2"	10'-6 1/2"	50'-10"	51'-5 1/2"	1050	5.7	15'-6"	288	1.9
66'	24'-0 1/2"	11'-1"	53'-10"	54'-5 1/2"	1110	6.0	16'-4"	304	2.0
69'	25'-1 1/2"	11'-6 1/2"	56'-10"	57'-5 1/2"	1170	6.3	17'-2"	320	2.1
72'	26'-2 1/2"	12'-1"	59'-10"	60'-5 1/2"	1230	6.6	18'-0"	336	2.2
75'	27'-3 1/2"	12'-6 1/2"	62'-10"	63'-5 1/2"	1290	6.9	18'-8"	352	2.3
78'	28'-4 1/2"	13'-1"	65'-10"	66'-5 1/2"	1350	7.2	19'-6"	368	2.4
81'	29'-5 1/2"	13'-6 1/2"	68'-10"	69'-5 1/2"	1410	7.5	20'-4"	384	2.5
84'	30'-6 1/2"	14'-1"	71'-10"	72'-5 1/2"	1470	7.8	21'-2"	400	2.6
87'	31'-7 1/2"	14'-6 1/2"	74'-10"	75'-5 1/2"	1530	8.1	22'-0"	416	2.7
90'	32'-8 1/2"	15'-1"	77'-10"	78'-5 1/2"	1590	8.4	22'-8"	432	2.8
93'	33'-9 1/2"	15'-6 1/2"	80'-10"	81'-5 1/2"	1650	8.7	23'-6"	448	2.9
96'	35'-0 1/2"	16'-1"	83'-10"	84'-5 1/2"	1710	9.0	24'-4"	464	3.0
99'	36'-1 1/2"	16'-6 1/2"	86'-10"	87'-5 1/2"	1770	9.3	25'-2"	480	3.1
102'	37'-2 1/2"	17'-1"	89'-10"	90'-5 1/2"	1830	9.6	26'-0"	496	3.2
105'	38'-3 1/2"	17'-6 1/2"	92'-10"	93'-5 1/2"	1890	9.9	26'-8"	512	3.3
108'	39'-4 1/2"	18'-1"	95'-10"	96'-5 1/2"	1950	10.2	27'-6"	528	3.4
111'	40'-5 1/2"	18'-6 1/2"	98'-10"	99'-5 1/2"	2010	10.5	28'-4"	544	3.5
114'	41'-6 1/2"	19'-1"	101'-10"	102'-5 1/2"	2070	10.8	29'-2"	560	3.6
117'	42'-7 1/2"	19'-6 1/2"	104'-10"	105'-5 1/2"	2130	11.1	30'-0"	576	3.7
120'	43'-8 1/2"	20'-1"	107'-10"	108'-5 1/2"	2190	11.4	30'-8"	592	3.8
123'	44'-9 1/2"	20'-6 1/2"	110'-10"	111'-5 1/2"	2250	11.7	31'-6"	608	3.9
126'	46'-0 1/2"	21'-1"	113'-10"	114'-5 1/2"	2310	12.0	32'-4"	624	4.0
129'	47'-1 1/2"	21'-6 1/2"	116'-10"	117'-5 1/2"	2370	12.3	33'-2"	640	4.1
132'	48'-2 1/2"	22'-1"	119'-10"	120'-5 1/2"	2430	12.6	34'-0"	656	4.2
135'	49'-3 1/2"	22'-6 1/2"	122'-10"	123'-5 1/2"	2490	12.9	34'-8"	672	4.3
138'	50'-4 1/2"	23'-1"	125'-10"	126'-5 1/2"	2550	13.2	35'-6"	688	4.4
141'	51'-5 1/2"	23'-6 1/2"	128'-10"	129'-5 1/2"	2610	13.5	36'-4"	704	4.5
144'	52'-6 1/2"	24'-1"	131'-10"	132'-5 1/2"	2670	13.8	37'-2"	720	4.6
147'	53'-7 1/2"	24'-6 1/2"	134'-10"	135'-5 1/2"	2730	14.1	38'-0"	736	4.7
150'	54'-8 1/2"	25'-1"	137'-10"	138'-5 1/2"	2790	14.4	38'-8"	752	4.8
153'	55'-9 1/2"	25'-6 1/2"	140'-10"	141'-5 1/2"	2850	14.7	39'-6"	768	4.9
156'	57'-0 1/2"	26'-1"	143'-10"	144'-5 1/2"	2910	15.0	40'-4"	784	5.0
159'	58'-1 1/2"	26'-6 1/2"	146'-10"	147'-5 1/2"	2970	15.3	41'-2"	800	5.1
162'	59'-2 1/2"	27'-1"	149'-10"	150'-5 1/2"	3030	15.6	42'-0"	816	5.2
165'	60'-3 1/2"	27'-6 1/2"	152'-10"	153'-5 1/2"	3090	15.9	42'-8"	832	5.3
168'	61'-4 1/2"	28'-1"	155'-10"	156'-5 1/2"	3150	16.2	43'-6"	848	5.4
171'	62'-5 1/2"	28'-6 1/2"	158'-10"	159'-5 1/2"	3210	16.5	44'-4"	864	5.5
174'	63'-6 1/2"	29'-1"	161'-10"	162'-5 1/2"	3270	16.8	45'-2"	880	5.6
177'	64'-7 1/2"	29'-6 1/2"	164'-10"	165'-5 1/2"	3330	17.1	46'-0"	896	5.7
180'	65'-8 1/2"	30'-1"	167'-10"	168'-5 1/2"	3390	17.4	46'-8"	912	5.8
183'	66'-9 1/2"	30'-6 1/2"	170'-10"	171'-5 1/2"	3450	17.7	47'-6"	928	5.9
186'	68'-0 1/2"	31'-1"	173'-10"	174'-5 1/2"	3510	18.0	48'-4"	944	6.0
189'	69'-1 1/2"	31'-6 1/2"	176'-10"	177'-5 1/2"	3570	18.3	49'-2"	960	6.1
192'	70'-2 1/2"	32'-1"	179'-10"	180'-5 1/2"	3630	18.6	50'-0"	976	6.2
195'	71'-3 1/2"	32'-6 1/2"	182'-10"	183'-5 1/2"	3690	18.9	50'-8"	992	6.3
198'	72'-4 1/2"	33'-1"	185'-10"	186'-5 1/2"	3750	19.2	51'-6"	1008	6.4
201'	73'-5 1/2"	33'-6 1/2"	188'-10"	189'-5 1/2"	3810	19.5	52'-4"	1024	6.5
204'	74'-6 1/2"	34'-1"	191'-10"	192'-5 1/2"	3870	19.8	53'-2"	1040	6.6
207'	75'-7 1/2"	34'-6 1/2"	194'-10"	195'-5 1/2"	3930	20.1	54'-0"	1056	6.7
210'	76'-8 1/2"	35'-1"	197'-10"	198'-5 1/2"	3990	20.4	54'-8"	1072	6.8
213'	77'-9 1/2"	35'-6 1/2"	200'-10"	201'-5 1/2"	4050	20.7	55'-6"	1088	6.9
216'	79'-0 1/2"	36'-1"	203'-10"	204'-5 1/2"	4110	21.0	56'-4"	1104	7.0
219'	80'-1 1/2"	36'-6 1/2"	206'-10"	207'-5 1/2"	4170	21.3	57'-2"	1120	7.1
222'	81'-2 1/2"	37'-1"	209'-10"	210'-5 1/2"	4230	21.6	58'-0"	1136	7.2
225'	82'-3 1/2"	37'-6 1/2"	212'-10"	213'-5 1/2"	4290	21.9	58'-8"	1152	7.3
228'	83'-4 1/2"	38'-1"	215'-10"	216'-5 1/2"	4350	22.2	59'-6"	1168	7.4
231'	84'-5 1/2"	38'-6 1/2"	218'-10"	219'-5 1/2"	4410	22.5	60'-4"	1184	7.5
234'	85'-6 1/2"	39'-1"	221'-10"	222'-5 1/2"	4470	22.8	61'-2"	1200	7.6
237'	86'-7 1/2"	39'-6 1/2"	224'-10"	225'-5 1/2"	4530	23.1	62'-0"	1216	7.7
240'	87'-8 1/2"	40'-1"	227'-10"	228'-5 1/2"	4590	23.4	62'-8"	1232	7.8
243'	88'-9 1/2"	40'-6 1/2"	230'-10"	231'-5 1/2"	4650	23.7	63'-6"	1248	7.9
246'	90'-0 1/2"	41'-1"	233'-10"	234'-5 1/2"	4710	24.0	64'-4"	1264	8.0
249'	91'-1 1/2"	41'-6 1/2"	236'-10"	237'-5 1/2"	4770	24.3	65'-2"	1280	8.1
252'	92'-2 1/2"	42'-1"	239'-10"	240'-5 1/2"	4830	24.6	66'-0"	1296	8.2
255'	93'-3 1/2"	42'-6 1/2"	242'-10"	243'-5 1/2"	4890	24.9	66'-8"	1312	8.3
258'	94'-4 1/2"	43'-1"	245'-10"	246'-5 1/2"	4950	25.2	67'-6"	1328	8.4
261'	95'-5 1/2"	43'-6 1/2"	248'-10"	249'-5 1/2"	5010	25.5	68'-4"	1344	8.5
264'	96'-6 1/2"	44'-1"	251'-10"	252'-5 1/2"	5070	25.8	69'-2"	1360	8.6
267'	97'-7 1/2"	44'-6 1/2"	254'-10"	255'-5 1/2"	5130	26.1	70'-0"	1376	8.7
270'	98'-8 1/2"	45'-1"	257'-10"	258'-5 1/2"	5190	26.4	70'-8"	1392	8.8
273'	99'-9 1/2"	45'-6 1/2"	260'-10"	261'-5 1/2"	5250	26.7	71'-6"	1408	8.9
276'	101'-0 1/2"	46'-1"	263'-10"	264'-5 1/2"	5310	27.0	72'-4"	1424	9.0
279'	102'-1 1/2"	46'-6 1/2"	266'-10"	267'-5 1/2"	5370	27.3	73'-2"	1440	9.1
282'	103'-2 1/2"	47'-1"	269'-10"	270'-5 1/2"	5430	27.6	74'-0"	1456	9.2
285'	104'-3 1/2"	47'-6 1/2"	272'-10"	273'-5 1/2"	5490	27.9	74'-8"	1472	9.3
288'	105'-4 1/2"	48'-1"	275'-10"	276'-5 1/2"	5550	28.2	75'-6"	1488	9.4
291'	106'-5 1/2"	48'-6 1/2"	278'-10"	279'-5 1/2"	5610	28.5	76'-4"	1504	9.5
294'	107'-6 1/2"	49'-1"	281'-10"	282'-5 1/2"	5670	28.8	77'-2"	1520	9.6
297'	108'-7 1/2"	49'-6 1/2"	284'-10"	285'-5 1/2"	5730	29.1	78'-0"	1536	9.7
300'	109'-8 1/2"	50'-1"	287'-10"	288'-5 1/2"	5790	29.4	78'-8"	1552	9.8
303'	110'-9 1/2"	50'-6 1/2"	290'-10"	291'-5 1/2"	5850	29.7	79'-6"	1568	9.9
306'	112'-0 1/2"	51'-1"	293'-10"	294'-5 1/2"	5910	30.0	80'-4"	1584	10.0
309'	113'-1 1/2"	51'-6 1/2"	296'-10"	297'-5 1/2"	5970	30.3	81'-2"	1600	10.1
312'	114'-2 1/2"	52'-1"	2						

EXHIBIT 3-

EXISTING & PROPOSED DRAINAGE MAPS

Date: Jun 23, 2023, 10:57am User ID: rtsukagoshi
 File: K:\082_01\02_Design\Civil\WPAP_Existing_Drainage_Area.dwg

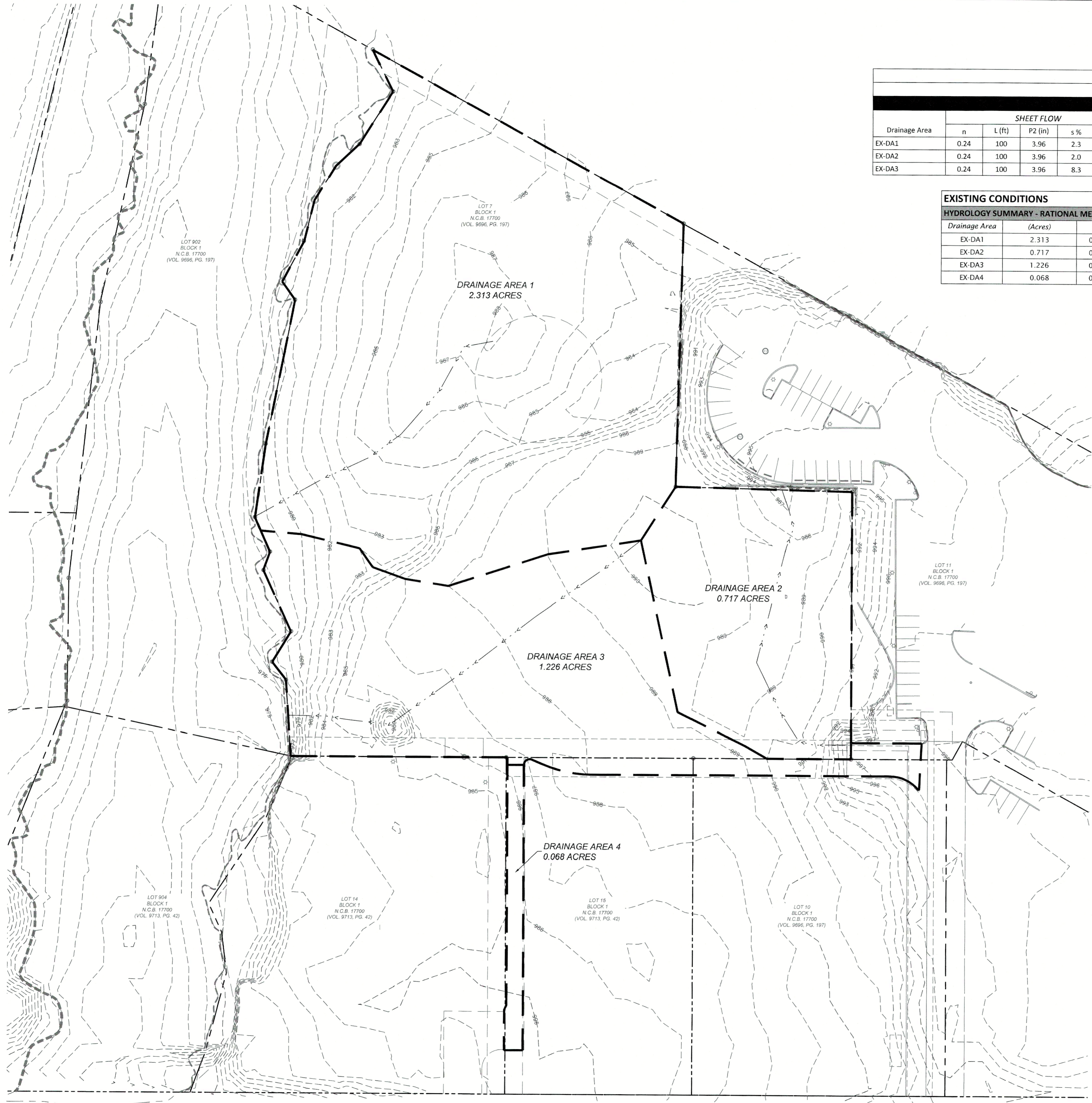

F.M. LOOP 1604
 (300' R.O.W.)

EXISTING CONDITIONS														
Time Of Concentration Calculation - SCS TR-55 Method														
Drainage Area	SHEET FLOW					SHALLOW CONCENTRATED FLOW					CHANNEL FLOW		TOTAL Tt(min)	
	n	L (ft)	P2 (in)	s %	Tt(min)	Paved/Unpaved	V (ft/s)	L (ft)	s (%)	Tt(min)	L (ft)	V (ft/s)		Tt(min)
EX-DA1	0.24	100	3.96	2.3	12.1	Unpaved	3.6	141	4.90	0.7				12.80
EX-DA2	0.24	100	3.96	2.0	12.8	Unpaved	3.8	226	5.50	1.0				13.80
EX-DA3	0.24	100	3.96	8.3	7.3	Unpaved	4.6	149	8.22	0.5				7.80

EXISTING CONDITIONS									
HYDROLOGY SUMMARY - RATIONAL METHOD									
Drainage Area	(Acres)	C	Ttot (min)	I5 (in/hr)	I25 (in/hr)	I100 (in/hr)	Q5 (ft3/s)	Q25 (ft3/s)	Q100 (ft3/s)
EX-DA1	2.313	0.53	12.8	5.70	7.95	9.93	6.99	9.75	12.17
EX-DA2	0.717	0.53	13.8	5.51	7.66	9.55	2.09	2.91	3.63
EX-DA3	1.226	0.53	7.8	6.87	9.62	12.07	4.46	6.25	7.84
EX-DA4	0.068	0.53	5.0	7.88	11.00	13.79	0.28	0.40	0.50

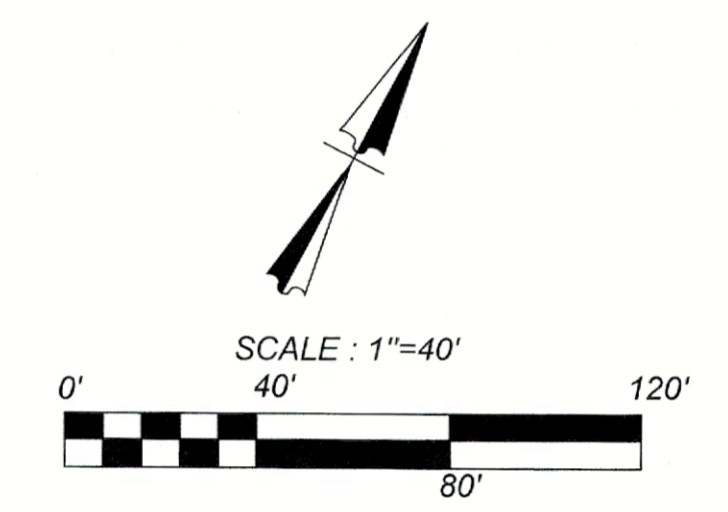

LEGEND	
PROPERTY LINE	---
EXISTING CONTOUR	- - - -
DRAINAGE BOUNDARY	---
SWALE	← - - - -

KFW
ENGINEERS + SURVEYING
 The Joint Center Engineering & Design, Inc.
 Phone # (210) 979-8444 • Fax # (210) 979-8441
 TBP# Firm # 9515 • TBP#S Firm # 10122800

STATE OF TEXAS
 FRANK D. COREY
 103068
 LICENSED PROFESSIONAL ENGINEER
 6/23/23

ELSEWHERE GARDEN BAR & KITCHEN
 WATER POLLUTION ABATEMENT PLAN
 EXISTING CONDITION DRAINAGE MAP

JOB NO. _____
 DATE: _____
 DRAWN: _____ CHECKED: _____

SHEET NUMBER:
EX-3A

ISSUE DATE

REVISIONS

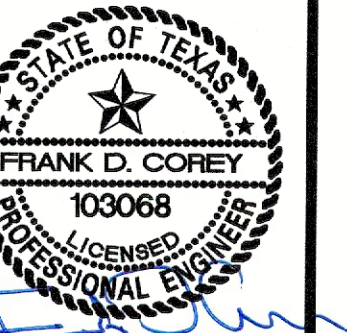

6/23/23

**ELSEWHERE GARDEN BAR & KITCHEN
 WATER POLLUTION ABATEMENT PLAN
 PROPOSED CONDITION DRAINAGE MAP**

JOB NO.
 DATE:
 DRAWN: - CHECKED:
 SHEET NUMBER:

EX-3B

PROPOSED CONDITIONS														
Time Of Concentration Calculation - SCS TR-55 Method														
Drainage Area	SHEET FLOW					SHALLOW CONCENTRATED FLOW				CHANNEL FLOW		TOTAL		
	n	L (ft)	P2 (in)	s %	Tt(min)	Paved/Unpaved	V (ft/s)	L (ft)	s (%)	Tt(min)	L (ft)	V (ft/s)	Tt(min)	Tt(min)
PROP-DA1	0.24	100	3.96	3.5	10.3	Unpaved	4.4	72	7.30	0.3				10.60
PROP-DA2	0.24	100	3.96	8.5	7.2	Unpaved	2.0	132	1.50	1.1				8.30
PROP-DA3	0.15	71	3.96	1.8	7.0	Paved	2.5	118	1.50	0.8	114	6	0	7.80
PROP-DA4	0.013	100	3.96	1.1	5.0	Paved	2.1	98	1.10	0.8				5.80

PROPOSED/ULTIMATE CONDITIONS										
HYDROLOGY SUMMARY - RATIONAL METHOD										
Drainage Area	(Acres)	C	Ttot (min)	15 (in/hr)	125 (in/hr)	1100 (in/hr)	Q5 (ft ³ /s)	Q25 (ft ³ /s)	Q100 (ft ³ /s)	
DA-1	1.573	0.53	10.6	6.17	8.63	10.80	5.14	7.19	9.00	
DA-2	0.397	0.53	8.3	6.73	9.43	11.83	1.42	1.98	2.49	
DA-3	2.286	0.96	7.8	6.87	9.62	12.07	15.08	21.11	26.49	
DA-4	0.068	0.96	5.8	7.54	10.54	13.22	0.49	0.69	0.86	

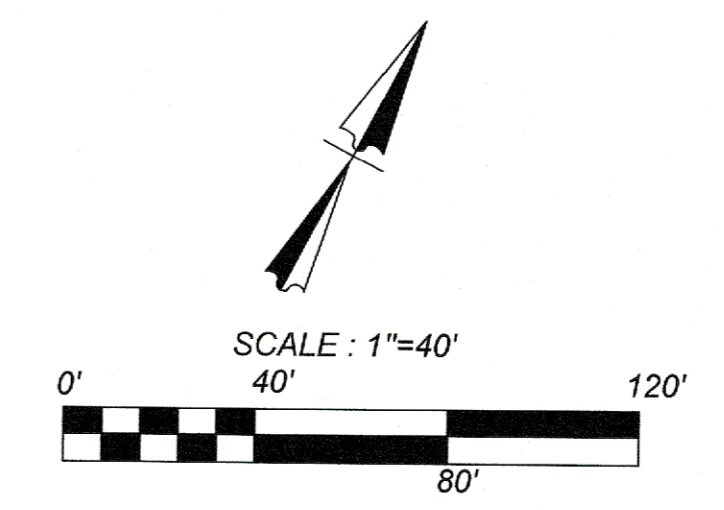

LEGEND

- PROPERTY LINE ————
- EXISTING CONTOUR - - - - -
- PROPOSED CONTOUR ————
- DRAINAGE BOUNDARY ————
- SWALE — - - - -

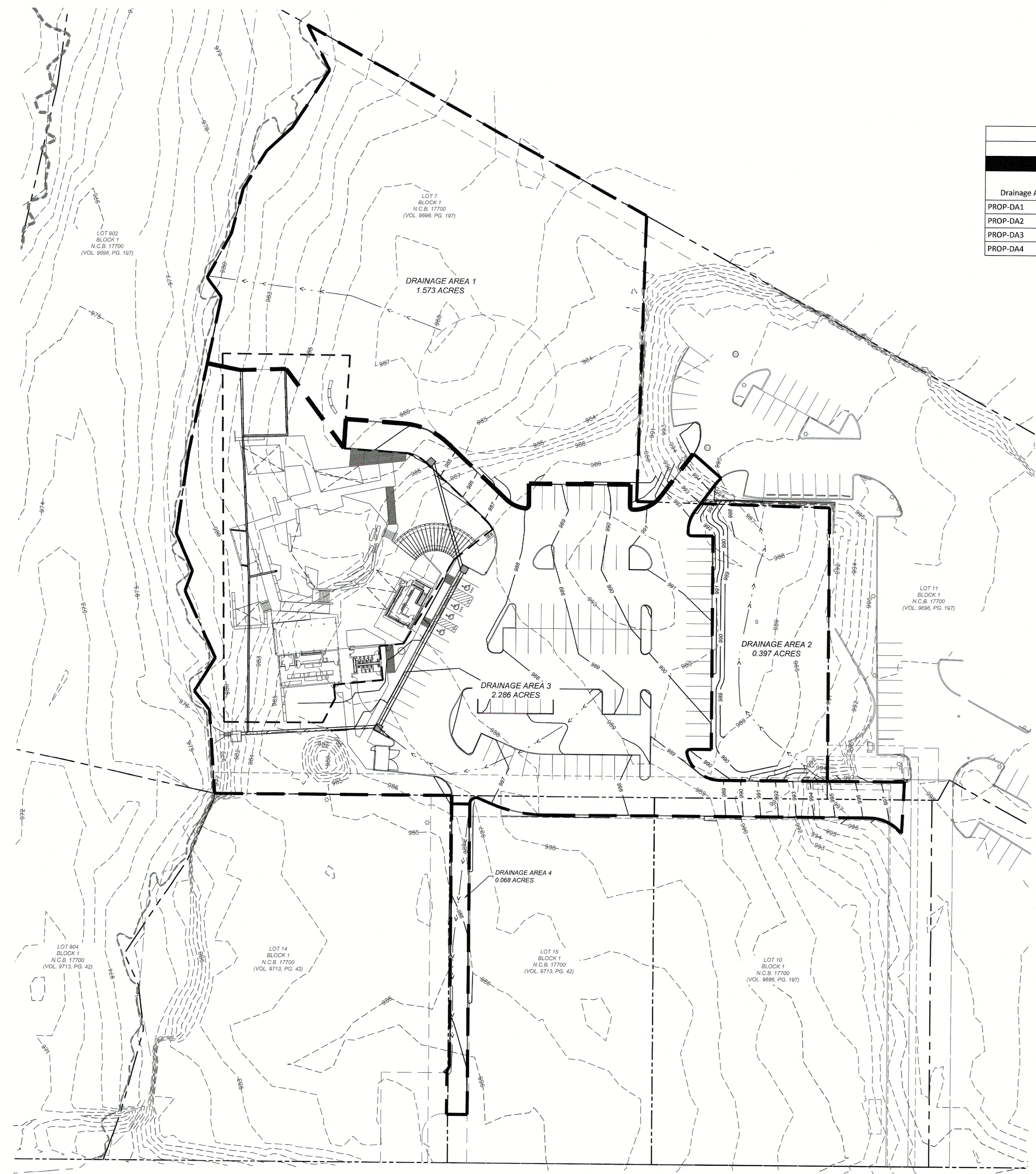

F.M. LOOP 1604
 (300' R.O.W.)

EXHIBIT 4-

RECORDED WARRANTY DEEDS

Capital Title

GF# 21-632358-DD

NOTICE OF CONFIDENTIALITY RIGHTS: IF YOU ARE A NATURAL PERSON, YOU MAY REMOVE OR STRIKE ANY OF THE FOLLOWING INFORMATION FROM THIS INSTRUMENT BEFORE IT IS FILED FOR RECORD IN THE PUBLIC RECORDS: YOUR SOCIAL SECURITY NUMBER OR YOUR DRIVERS LICENSE NUMBER.

SPECIAL WARRANTY DEED

Date: February 2, 2022

Grantor: SA Land Holdings, LP,
a Texas limited partnership

Grantor's Mailing Address (including county):

c/o SA Land Holdings GP, LLC
5 Four Coins Drive
Canonsburg, Washington County, PA 15317

Grantee: The Ridge East, LLC,
a Texas limited liability company

Grantee's Mailing Address (including county):

6222 West IH-10
San Antonio, Bexar County, Texas 78201

Consideration: Ten Dollars (\$10.00) and other valuable consideration

Property (including any improvements):

Tract One: Lots 7 and 902, Block 1, New City Block 17700, The Ridge East 2, an Addition to the City of San Antonio, Bexar County, Texas, according to the Map or Plat thereof recorded in Volume 9696, Pages 197-198, Deed and Plat Records of Bexar County, Texas.

Tract Two (Easement Estate): Easement Estate(s) created by that certain Declaration of Reciprocal Easements with Related Covenants, Conditions and Restrictions, dated August 10, 2009, and recorded on or about August 14, 2009, in Volume 14129, Page 1584, Official Public Records of Bexar County, Texas, as amended by that certain First Amendment to the Declaration of Reciprocal Easements with Related Covenants, Conditions and Restrictions, dated March 24, 2016, and recorded on or about March 29, 2016, in Volume 17768, Page 2034, Official Public Records of Bexar County, Texas, and Second Amendment to the Declaration of Reciprocal Easements with Related Covenants, Conditions and Restrictions, dated January 16, 2017, and recorded on or about January 18, 2017, in Volume 18313, Page 1931, Official Public Records of Bexar County, Texas .

Reservations from Conveyance and Warranty:

None.

Exceptions to Conveyance and Warranty:

All of the permitted exceptions described on Exhibit "A," attached hereto and incorporated herein by reference.

Grantor, for the consideration and subject to the reservations from and exceptions to conveyance and warranty, grants, sells and conveys unto Grantee, Tract One of the Property, together with all and singular the rights and appurtenances thereto in any way belonging, TO HAVE AND TO HOLD it to Grantee, and Grantee's successors or assigns forever. Grantor binds Grantor and Grantor's successors to WARRANT AND FOREVER DEFEND all and singular Tract One of the Property to Grantee, Grantee's heirs, executors, administrators, successors and assigns, against every person whomsoever lawfully claiming or to claim the same or any part thereof, except as to the reservations from and exceptions to conveyance and warranty, when the claim is by, through, or under Grantor, but not otherwise.

For the same consideration, subject to the reservations from and exceptions to conveyance and warranty, Grantor has GRANTED, BARGAINED, SOLD, and CONVEYED, and by these presents does GRANT, BARGAIN, SELL, and CONVEY unto Grantee, without warranty, express or implied, all right, title and interest of Grantor, *if any*, in and to: (1) all strips and gores, if any, between the Property and any abutting properties; (2) all roads, alleys, rights-of-way, easements, streets and ways adjacent to or serving the Property, and rights of ingress and egress thereto; and (3) Tract Two described above. All warranties that arise by common law as well as the warranties in Section 5.023 of the Texas Property Code (or its successor) are excluded.

BY ACCEPTANCE OF THIS SPECIAL WARRANTY DEED, GRANTEE ACCEPTS THE PROPERTY "AS IS" AND "WHERE IS", WITH ALL FAULTS, AND GRANTEE AGREES THAT, EXCEPT FOR THE WARRANTIES OF TITLE TO BE CONTAINED IN THIS DEED AND THE LIMITED EXPRESS WRITTEN REPRESENTATIONS CONTAINED IN THAT CERTAIN COMMERCIAL CONTRACT – UNIMPROVED PROPERTY, DATED THE 13TH DAY OF OCTOBER, 2021, AND AS AMENDED BY THAT CERTAIN FIRST AMENDMENT DATED THE 25TH DAY OF OCTOBER, 2021 (COLLECTIVELY THE "AGREEMENT"), NEITHER GRANTOR NOR ANY OF GRANTOR'S PARTNERS OR ANY OF THEIR RESPECTIVE OFFICERS, MEMBERS, MANAGERS, DIRECTORS, REPRESENTATIVES, BROKERS, ATTORNEYS AND/OR AGENTS (COLLECTIVELY THE "GRANTOR RELATED PARTIES") HAVE MADE OR GIVEN ANY WARRANTIES, GUARANTEES, OR REPRESENTATIONS OF ANY KIND WHATSOEVER, REGARDING ANY MATTER RELATING TO THE AGREEMENT OR THE PROPERTY, WHETHER ORAL OR WRITTEN, EXPRESS OR IMPLIED. GRANTEE SPECIFICALLY AGREES AND ACKNOWLEDGES THAT EXCEPT AS SET FORTH IN THE AGREEMENT, THERE ARE NO EXPRESS OR IMPLIED WARRANTIES (i) OF HABITABILITY, MERCHANTABILITY, SUITABILITY, OR FITNESS FOR A PARTICULAR PURPOSE, (ii) REGARDING THE PRESENT OR FUTURE VALUE, PROFITABILITY, PERFORMANCE OR PRODUCTIVITY OF THE PROPERTY, (iii) REGARDING THE PAST OR PRESENT COMPLIANCE BY GRANTOR OF LAWS RELATED TO LAND USE, ENVIRONMENTAL MATTERS, POLLUTION, PRESENCE OF ASBESTOS OR LEAD BASED PAINT AT THE PROPERTY, OR ANY LAWS PERTAINING TO THE HANDLING, GENERATING, TREATING, STORING, TRANSPORTING, OR DISPOSING, OR THE PRESENCE OR ABSENCE ON THE PROPERTY OF HAZARDOUS OR TOXIC WASTE OR SUBSTANCES AS SUCH TERMS ARE DEFINED IN FEDERAL, STATE AND LOCAL LAWS, (iv) THE DECLARATION FILED OR RECORD AND RESTRICTING THE PROPERTY, ANY OTHER RESTRICTIVE COVENANTS OR ANY EASEMENTS OF ANY KIND OR (v) THE EXTENT OR ABILITY OF GRANTEE TO DEVELOP THE FLOOD PLAIN ON THE PROPERTY OR ANY OTHER PART OF THE PROPERTY. GRANTEE SPECIFICALLY AFFIRMS AND ACKNOWLEDGES THAT, EXCEPT FOR THE WARRANTIES OF TITLE CONTAINED IN THIS DEED AND THE LIMITED EXPRESS WRITTEN REPRESENTATIONS

CONTAINED IN THE AGREEMENT, GRANTEE IS RELYING EXCLUSIVELY UPON ITS OWN JUDGMENT IN ACQUIRING THE PROPERTY.

Taxes having been prorated at Closing, all real property taxes and assessments as to the Property for the current year and subsequent years are the responsibility of Grantee and are assumed by Grantee. When the context requires, singular nouns and pronouns include the plural.

GRANTOR:

SA LAND HOLDINGS, LP,
a Texas limited partnership

By: SA Land Holdings GP, LLC,
a Texas limited liability company
its general partner

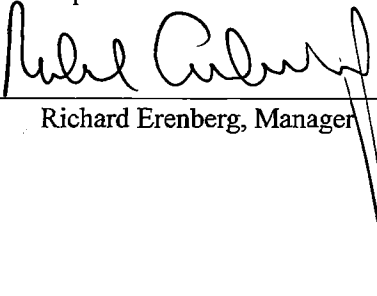
By: 
Richard Erenberg, Manager

STATE OF PENNSYLVANIA §
 §
COUNTY OF WASHINGTON §

BEFORE ME, the undersigned authority, on this day personally appeared Richard M. Erenberg, Manager of SA Land Holdings GP, LLC, a Texas limited liability company, the general partner of SA Land Holdings, L.P., a Texas limited partnership, known to me to be the person whose name is subscribed to the foregoing instrument, and acknowledged to me that he executed the same for the purposes therein expressed on behalf of said limited partnership.

GIVEN UNDER MY HAND AND SEAL OF OFFICE on this 1st day of February, 2022.

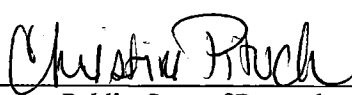
Notary Public, State of Pennsylvania
Commonwealth of Pennsylvania - Notary Seal
Christine Pituch, Notary Public
Washington County
My commission expires January 22, 2026
Commission number 1281340
Member, Pennsylvania Association of Notaries

[additional signature on the following page]

GRANTEE:

THE RIDGE EAST, LLC,
a Texas limited liability company

By: *[Signature]*

Name: Jimi Ellis

Its: Manager

STATE OF TEXAS §
 §
COUNTY OF BEXAR §

BEFORE ME, the undersigned authority, on this day personally appeared Jimi Ellis, Manager, of The Ridge East, LLC, a Texas limited liability company, known to me to be the person whose name is subscribed to the foregoing instrument, and acknowledged to me that he/she executed the same for the purposes therein expressed on behalf of said limited liability company.

GIVEN UNDER MY HAND AND SEAL OF OFFICE on this 2 day of February 2022.

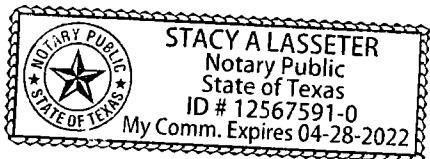

[Signature]
Notary Public, State of Texas

16973.0306 SA Land Holdings/RIDGE EAST/Closing Docs/SWD (orig).docx

EXHIBIT "A"

1. Standby fees, taxes and assessments by any taxing authority for the year 2022 and subsequent years, not yet due and payable.
2. The following restrictive covenants of record itemized below:

Volume 9696, Pages 197-198, Deed and Plat Records, Bexar County, Texas; and Volume 9251, Page 2299, Volume 11918, Page 1379, Volume 14129, Page 1584, Volume 17768, Page 2034, Volume 18313, Page 1931, and Volume 18540, Page 1931, Real Property Records, Bexar County, Texas.
3. Any discrepancies, conflicts, or shortages in area or boundary lines, or any encroachments or protrusions, or any overlapping of improvements (if any are in existence.)
4. All leases, grants, exceptions or reservations of coal, lignite, oil, gas and other minerals, together with all a. rights, privileges and immunities relating thereto, appearing in the Public Records
5. The following easement(s) and/or building line(s) affecting the subject property as shown on Map or Plat recorded in Volume 9696, Pages 197-198, Deed and Plat Records, Bexar County, Texas:

50 foot radius solution feature buffer easement, as to Lot 7.

12 foot private drainage easement, as to Lot 7.

Fence encroaches upon 12 foot private drainage easement, as to Lot 7.

15 foot irrevocable ingress/egress easement, as to Lot 7.

12 foot water easement, as to Lot 7.

Variable width irrevocable ingress/egress, electric, gas, telephone, cable TV and drainage easement, as to Lot 7.

15 foot water easement, as to Lot 7.

30 foot irrevocable ingress/egress easement, as to Lot 7.

FEMA Flood Zone X, as to Lot 7.

Variable width drainage easement, as to Lot 902.

FEMA Flood Zone AE, as to Lot 902.
6. Terms, conditions and regulations regarding subject property being within the Edwards Recharge Zone and this development being subject to that certain Chapter 34, Article VI, Division 6 of the San Antonio city code entitled Aquifer Recharge Zone and Watershed Protection, as set forth in plat notation on plat recorded in Volume 9696, Pages 197-198, Deed and Plat Records, Bexar County, Texas.
7. Terms, conditions, regulations and provisions of the Edwards Aquifer Protection Plan, as disclosed by Affidavit executed by Richard M. Erenberg, Principal, Design Investors, L.P., filed February 6, 2009, recorded in Volume 13847, Page 2158, Real Property Records, Bexar County, Texas.

8. Terms and conditions as set forth in Partial Assignment of Sanitary Sewer and Water Capacity, dated effective August 11, 2009, filed August 14, 2009, recorded in Volume 14129, Page 1611, Real Property Records, Bexar County, Texas.
9. Terms and conditions as set forth in Utility Service Agreement, by and between the San Antonio Water and SA Land Holdings, LP, dated effective March 30, 2015, filed April 2, 2015, recorded in Volume 17164, Page 1698, Real Property Records, Bexar County, Texas.
10. Easement as created in instrument executed by SA Land Holdings, LP, a Texas limited partnership to Southwestern Bell Telephone Company, a Delaware corporation, dated May 24, 2016, filed June 14, 2016, recorded in Volume 17909, Page 1476, Real Property Records, Bexar County, Texas, as to Lot 7.
11. Terms, conditions and stipulations as set forth in Sign Easement and Maintenance Agreement, dated effective October 1, 2017, recoded in Volume 18793, Page 1158, Real Property Records, Bexar County, Texas, as to Lot 7.
12. Terms, conditions and stipulations as set forth in Sign Master Plan for The Ridge, dated February 12, 2018, filed March 14, 2018, recorded in Volume 19035, Page 1308, Real Property Records, Bexar County, Texas, as to Lot 7.

File Information

**eFILED IN THE OFFICIAL PUBLIC eRECORDS OF BEXAR COUNTY
LUCY ADAME-CLARK, BEXAR COUNTY CLERK**

Document Number: 20220031102
Recorded Date: February 07, 2022
Recorded Time: 1:11 PM
Total Pages: 7
Total Fees: \$46.00

**** THIS PAGE IS PART OF THE DOCUMENT ****

**** Do Not Remove ****

Any provision herein which restricts the sale or use of the described real property because of race is invalid and unenforceable under Federal law

STATE OF TEXAS, COUNTY OF BEXAR

I hereby Certify that this instrument was eFILED in File Number Sequence on this date and at the time stamped hereon by me and was duly eRECORDED in the Official Public Record of Bexar County, Texas on: 2/7/2022 1:11 PM



Lucy Adame-Clark
Lucy Adame-Clark
Bexar County Clerk



Engineering & Design

Colliers Engineering & Design is a trusted provider of multi-discipline engineering, design and consulting services providing customized solutions for public and private clients through a network of offices nationwide.

For a full listing of our office locations, please visit colliersengineering.com

1 877 627 3772



*Civil/Site • Traffic/Transportation • Governmental • Survey/Geospatial
Infrastructure • Geotechnical/Environmental • Telecommunications • Utilities/Energy*