

**WATER POLLUTION ABATEMENT PLAN
FOR
HALFTIME #1 – CONVENIENCE STORE**



**SAN ANTONIO ETJ, BEXAR COUNTY, TX
BULVERDE AND MARSHALL RD.**

Prepared by:



**ENGINEERING
+ SURVEYING**

**11903 Jones Maltsberger Rd, Suite 102
San Antonio, TX 78216
210-774-5504
TBPE FIRM 17992**

Prepared for:

**HALFTIME
Karim Ali
7410 Blanco Road, Suite 225
San Antonio, TX 78216**



Texas Commission on Environmental Quality

Edwards Aquifer Application Cover Page

Our Review of Your Application

The Edwards Aquifer Program staff conducts an administrative and technical review of all applications. The turnaround time for administrative review can be up to 30 days as outlined in 30 TAC 213.4(e). Generally administrative completeness is determined during the intake meeting or within a few days of receipt. The turnaround time for technical review of an administratively complete Edwards Aquifer application is 90 days as outlined in 30 TAC 213.4(e). Please know that the review and approval time is directly impacted by the quality and completeness of the initial application that is received. In order to conduct a timely review, it is imperative that the information provided in an Edwards Aquifer application include final plans, be accurate, complete, and in compliance with [30 TAC 213](#).

Administrative Review

1. [Edwards Aquifer applications](#) must be deemed administratively complete before a technical review can begin. To be considered administratively complete, the application must contain completed forms and attachments, provide the requested information, and meet all the site plan requirements. The submitted application and plan sheets should be final plans. Please submit one full-size set of plan sheets with the original application, and half-size sets with the additional copies.

To ensure that all applicable documents are included in the application, the program has developed tools to guide you and web pages to provide all forms, checklists, and guidance. Please visit the below website for assistance: <http://www.tceq.texas.gov/field/eapp>.

2. This Edwards Aquifer Application Cover Page form (certified by the applicant or agent) must be included in the application and brought to the administrative review meeting.
3. Administrative reviews are scheduled with program staff who will conduct the review. Applicants or their authorized agent should call the appropriate regional office, according to the county in which the project is located, to schedule a review. The average meeting time is one hour.
4. In the meeting, the application is examined for administrative completeness. Deficiencies will be noted by staff and emailed or faxed to the applicant and authorized agent at the end of the meeting, or shortly after. Administrative deficiencies will cause the application to be deemed incomplete and returned.

An appointment should be made to resubmit the application. The application is re-examined to ensure all deficiencies are resolved. The application will only be deemed administratively complete when all administrative deficiencies are addressed.

5. If an application is received by mail, courier service, or otherwise submitted without a review meeting, the administrative review will be conducted within 30 days. The applicant and agent will be contacted with the results of the administrative review. If the application is found to be administratively incomplete, it can be retrieved from the regional office or returned by regular mail. If returned by mail, the regional office may require arrangements for return shipping.
6. If the geologic assessment was completed before October 1, 2004 and the site contains “possibly sensitive” features, the assessment must be updated in accordance with the *Instructions to Geologists* (TCEQ-0585 Instructions).

Technical Review

1. When an application is deemed administratively complete, the technical review period begins. The regional office will distribute copies of the application to the identified affected city, county, and groundwater conservation district whose jurisdiction includes the subject site. These entities and the public have 30 days to provide comments on the application to the regional office. All comments received are reviewed by TCEQ.
2. A site assessment is usually conducted as part of the technical review, to evaluate the geologic assessment and observe existing site conditions. The site must be accessible to our staff. The site boundaries should be

clearly marked, features identified in the geologic assessment should be flagged, roadways marked and the alignment of the Sewage Collection System and manholes should be staked at the time the application is submitted. If the site is not marked the application may be returned.

3. We evaluate the application for technical completeness and contact the applicant and agent via Notice of Deficiency (NOD) to request additional information and identify technical deficiencies. There are two deficiency response periods available to the applicant. There are 14 days to resolve deficiencies noted in the first NOD. If a second NOD is issued, there is an additional 14 days to resolve deficiencies. If the response to the second notice is not received, is incomplete or inadequate, or provides new information that is incomplete or inadequate, the application must be withdrawn or will be denied. Please note that because the technical review is underway, whether the application is withdrawn or denied **the application fee will be forfeited.**
4. The program has 90 calendar days to complete the technical review of the application. If the application is technically adequate, such that it complies with the Edwards Aquifer rules, and is protective of the Edwards Aquifer during and after construction, an approval letter will be issued. Construction or other regulated activity may not begin until an approval is issued.

Mid-Review Modifications

It is important to have final site plans prior to beginning the permitting process with TCEQ to avoid delays.

Occasionally, circumstances arise where you may have significant design and/or site plan changes after your Edwards Aquifer application has been deemed administratively complete by TCEQ. This is considered a “Mid-Review Modification”. Mid-Review Modifications may require redistribution of an application that includes the proposed modifications for public comment.

If you are proposing a Mid-Review Modification, two options are available:

- If the technical review has begun your application can be denied/withdrawn, your fees will be forfeited, and the plan will have to be resubmitted.
- TCEQ can continue the technical review of the application as it was submitted, and a modification application can be submitted at a later time.

If the application is denied/withdrawn, the resubmitted application will be subject to the administrative and technical review processes and will be treated as a new application. The application will be redistributed to the affected jurisdictions.

Please contact the regional office if you have questions. If your project is located in Williamson, Travis, or Hays County, contact TCEQ’s Austin Regional Office at 512-339-2929. If your project is in Comal, Bexar, Medina, Uvalde, or Kinney County, contact TCEQ’s San Antonio Regional Office at 210-490-3096

Please fill out all required fields below and submit with your application.

1. Regulated Entity Name: Halftime 1				2. Regulated Entity No.:			
3. Customer Name: Bulverde Marshall LLC				4. Customer No.:			
5. Project Type: (Please circle/check one)	<input type="checkbox"/> New	<input type="checkbox"/> Modification		<input type="checkbox"/> Extension		<input type="checkbox"/> Exception	
6. Plan Type: (Please circle/check one)	<input checked="" type="checkbox"/> WPAP	<input type="checkbox"/> CZP	<input checked="" type="checkbox"/> SCS	<input checked="" type="checkbox"/> UST	<input type="checkbox"/> AST	<input type="checkbox"/> EXP	<input type="checkbox"/> EXT
7. Land Use: (Please circle/check one)	<input type="checkbox"/> Residential		<input type="checkbox"/> Non-residential		8. Site (acres):		12.30
9. Application Fee:		10. Permanent BMP(s):					
11. SCS (Linear Ft.):		12. AST/UST (No. Tanks):					
13. County: Bexar		14. Watershed:				Salado Creek Watershed	

Application Distribution

Instructions: Use the table below to determine the number of applications required. One original and one copy of the application, plus additional copies (as needed) for each affected incorporated city, county, and groundwater conservation district are required. Linear projects or large projects, which cross into multiple jurisdictions, can require additional copies. Refer to the “Texas Groundwater Conservation Districts within the EAPP Boundaries” map found at:

http://www.tceq.texas.gov/assets/public/compliance/field_ops/eapp/EAPP%20GWCD%20map.pdf

For more detailed boundaries, please contact the conservation district directly.

Austin Region			
County:	Hays	Travis	Williamson
Original (1 req.)	—	—	—
Region (1 req.)	—	—	—
County(ies)	—	—	—
Groundwater Conservation District(s)	<input type="checkbox"/> Edwards Aquifer Authority <input type="checkbox"/> Barton Springs/ Edwards Aquifer <input type="checkbox"/> Hays Trinity <input type="checkbox"/> Plum Creek	<input type="checkbox"/> Barton Springs/ Edwards Aquifer	NA
City(ies) Jurisdiction	<input type="checkbox"/> Austin <input type="checkbox"/> Buda <input type="checkbox"/> Dripping Springs <input type="checkbox"/> Kyle <input type="checkbox"/> Mountain City <input type="checkbox"/> San Marcos <input type="checkbox"/> Wimberley <input type="checkbox"/> Woodcreek	<input type="checkbox"/> Austin <input type="checkbox"/> Bee Cave <input type="checkbox"/> Pflugerville <input type="checkbox"/> Rollingwood <input type="checkbox"/> Round Rock <input type="checkbox"/> Sunset Valley <input type="checkbox"/> West Lake Hills	<input type="checkbox"/> Austin <input type="checkbox"/> Cedar Park <input type="checkbox"/> Florence <input type="checkbox"/> Georgetown <input type="checkbox"/> Jerrell <input type="checkbox"/> Leander <input type="checkbox"/> Liberty Hill <input type="checkbox"/> Pflugerville <input type="checkbox"/> Round Rock

San Antonio Region					
County:	Bexar	Comal	Kinney	Medina	Uvalde
Original (1 req.)	—	—	—	—	—
Region (1 req.)	—	—	—	—	—
County(ies)	—	—	—	—	—
Groundwater Conservation District(s)	<input checked="" type="checkbox"/> Edwards Aquifer Authority <input type="checkbox"/> Trinity-Glen Rose	<input type="checkbox"/> Edwards Aquifer Authority	<input type="checkbox"/> Kinney	<input type="checkbox"/> EAA <input type="checkbox"/> Medina	<input type="checkbox"/> EAA <input type="checkbox"/> Uvalde
City(ies) Jurisdiction	<input type="checkbox"/> Castle Hills <input type="checkbox"/> Fair Oaks Ranch <input type="checkbox"/> Helotes <input type="checkbox"/> Hill Country Village <input type="checkbox"/> Hollywood Park <input type="checkbox"/> San Antonio (SAWS) <input type="checkbox"/> Shavano Park	<input type="checkbox"/> Bulverde <input type="checkbox"/> Fair Oaks Ranch <input type="checkbox"/> Garden Ridge <input type="checkbox"/> New Braunfels <input type="checkbox"/> Schertz	NA	<input checked="" type="checkbox"/> San Antonio ETJ (SAWS)	NA

I certify that to the best of my knowledge, that the application is complete and accurate. This application is hereby submitted to TCEQ for administrative review and technical review.	
Print Name of Customer/Authorized Agent	
	
Signature of Customer/Authorized Agent	Date

FOR TCEQ INTERNAL USE ONLY			
Date(s) Reviewed:		Date Administratively Complete:	
Received From:		Correct Number of Copies:	
Received By:		Distribution Date:	
EAPP File Number:		Complex:	
Admin. Review(s) (No.):		No. AR Rounds:	
Delinquent Fees (Y/N):		Review Time Spent:	
Lat./Long. Verified:		SOS Customer Verification:	
Agent Authorization Complete/Notarized (Y/N):		Fee Check:	Payable to TCEQ (Y/N):
Core Data Form Complete (Y/N):			Signed (Y/N):
Core Data Form Incomplete Nos.:			Less than 90 days old (Y/N):

General Information Form

In this Section:

TCEQ-0587
General Information Form

Attachment A
Road Map

Attachment B
USGS/Edwards Recharge Zone Map

Attachment C
Project Description

General Information Form

Texas Commission on Environmental Quality

For Regulated Activities on the Edwards Aquifer Recharge and Transition Zones and Relating to 30 TAC §213.4(b) & §213.5(b)(2)(A), (B) Effective June 1, 1999

To ensure that the application is administratively complete, confirm that all fields in the form are complete, verify that all requested information is provided, consistently reference the same site and contact person in all forms in the application, and ensure forms are signed by the appropriate party.

Note: Including all the information requested in the form and attachments contributes to more streamlined technical reviews.

Signature

To the best of my knowledge, the responses to this form accurately reflect all information requested concerning the proposed regulated activities and methods to protect the Edwards Aquifer. This **General Information Form** is hereby submitted for TCEQ review. The application was prepared by:

Print Name of Customer/Agent: Karim Ali

Date: 03/24/2023

Signature of Customer/Agent:



Project Information

1. Regulated Entity Name: Halftime 1
2. County: Bexar
3. Stream Basin: Salado Creek Watershed
4. Groundwater Conservation District (If applicable): Edwards Aquifer Authority
5. Edwards Aquifer Zone:
 - Recharge Zone
 - Transition Zone
6. Plan Type:
 - WPAP
 - SCS
 - Modification
 - AST
 - UST
 - Exception Request

7. Customer (Applicant):

Contact Person: Karim Ali
Entity: Bulverde Marshall LLC
Mailing Address: 7410 Blanco Rd, St. 225
City, State: San Antonio, Texas Zip: 78216
Telephone: _____ FAX: _____
Email Address: _____

8. Agent/Representative (If any):

Contact Person: Tyler Smith
Entity: UP Engineering LLC
Mailing Address: 11903 Jones Maltzberger Rd, Suite 102
City, State: TX Zip: 78216
Telephone: 210-774-5504 FAX: _____
Email Address: _____

9. Project Location:

- The project site is located inside the city limits of _____.
- The project site is located outside the city limits but inside the ETJ (extra-territorial jurisdiction) of San Antonio
- The project site is not located within any city's limits or ETJ.

10. The location of the project site is described below. The description provides sufficient detail and clarity so that the TCEQ's Regional staff can easily locate the project and site boundaries for a field investigation.

Summit Church Rd and Bulverde Rd, City of San Antonio ETJ, Texas, 78259

11. **Attachment A – Road Map.** A road map showing directions to and the location of the project site is attached. The project location and site boundaries are clearly shown on the map.
12. **Attachment B - USGS / Edwards Recharge Zone Map.** A copy of the official 7 ½ minute USGS Quadrangle Map (Scale: 1" = 2000') of the Edwards Recharge Zone is attached. The map(s) clearly show:
- Project site boundaries.
- USGS Quadrangle Name(s).
- Boundaries of the Recharge Zone (and Transition Zone, if applicable).
- Drainage path from the project site to the boundary of the Recharge Zone.
13. **The TCEQ must be able to inspect the project site or the application will be returned.** Sufficient survey staking is provided on the project to allow TCEQ regional staff to locate the boundaries and alignment of the regulated activities and the geologic or manmade features noted in the Geologic Assessment.
- Survey staking will be completed by this date: N/A

14. **Attachment C – Project Description.** Attached at the end of this form is a detailed narrative description of the proposed project. The project description is consistent throughout the application and contains, at a minimum, the following details:

- Area of the site
- Offsite areas
- Impervious cover
- Permanent BMP(s)
- Proposed site use
- Site history
- Previous development
- Area(s) to be demolished

15. Existing project site conditions are noted below:

- Existing commercial site
- Existing industrial site
- Existing residential site
- Existing paved and/or unpaved roads
- Undeveloped (Cleared)
- Undeveloped (Undisturbed/Uncleared)
- Other: _____

Prohibited Activities

16. I am aware that the following activities are prohibited on the Recharge Zone and are not proposed for this project:

- (1) Waste disposal wells regulated under 30 TAC Chapter 331 of this title (relating to Underground Injection Control);
- (2) New feedlot/concentrated animal feeding operations, as defined in 30 TAC §213.3;
- (3) Land disposal of Class I wastes, as defined in 30 TAC §335.1;
- (4) The use of sewage holding tanks as parts of organized collection systems; and
- (5) New municipal solid waste landfill facilities required to meet and comply with Type I standards which are defined in §330.41(b), (c), and (d) of this title (relating to Types of Municipal Solid Waste Facilities).
- (6) New municipal and industrial wastewater discharges into or adjacent to water in the state that would create additional pollutant loading.

17. I am aware that the following activities are prohibited on the Transition Zone and are not proposed for this project:

- (1) Waste disposal wells regulated under 30 TAC Chapter 331 (relating to Underground Injection Control);
- (2) Land disposal of Class I wastes, as defined in 30 TAC §335.1; and

- (3) New municipal solid waste landfill facilities required to meet and comply with Type I standards which are defined in §330.41 (b), (c), and (d) of this title.

Administrative Information

18. The fee for the plan(s) is based on:

- For a Water Pollution Abatement Plan or Modification, the total acreage of the site where regulated activities will occur.
 - For an Organized Sewage Collection System Plan or Modification, the total linear footage of all collection system lines.
 - For a UST Facility Plan or Modification or an AST Facility Plan or Modification, the total number of tanks or piping systems.
 - A request for an exception to any substantive portion of the regulations related to the protection of water quality.
 - A request for an extension to a previously approved plan.
19. Application fees are due and payable at the time the application is filed. If the correct fee is not submitted, the TCEQ is not required to consider the application until the correct fee is submitted. Both the fee and the Edwards Aquifer Fee Form have been sent to the Commission's:
- TCEQ cashier
 - Austin Regional Office (for projects in Hays, Travis, and Williamson Counties)
 - San Antonio Regional Office (for projects in Bexar, Comal, Kinney, Medina, and Uvalde Counties)
20. Submit one (1) original and one (1) copy of the application, plus additional copies as needed for each affected incorporated city, groundwater conservation district, and county in which the project will be located. The TCEQ will distribute the additional copies to these jurisdictions. The copies must be submitted to the appropriate regional office.
21. No person shall commence any regulated activity until the Edwards Aquifer Protection Plan(s) for the activity has been filed with and approved by the Executive Director.

Attachment A

Road Map

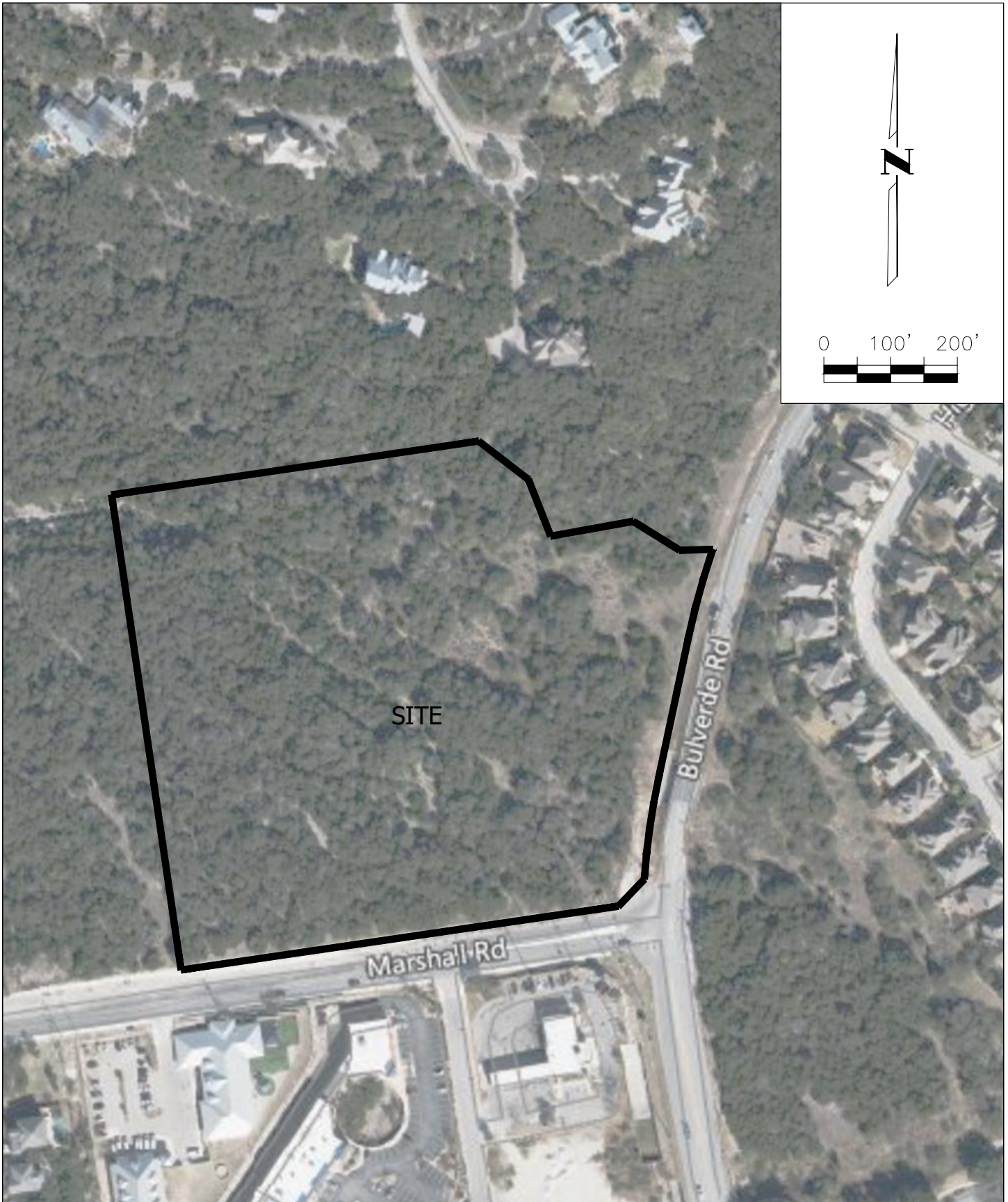

EXHIBIT

A

**BIG'S #212 C-STORE
BULVERDE RD AND
MARSHALL RD**

ROAD MAP



**ENGINEERING
+ SURVEYING**

11903 JONES MALTSBERGER RD., SUITE 102
SAN ANTONIO, TX 78216 TEL 210-774-5504
WWW.UPENGINEERING.COM TBPE F-17992
TBPLS F-10194606

Attachment B

USGS/Edwards Recharge Zone Map

Edwards Aquifer

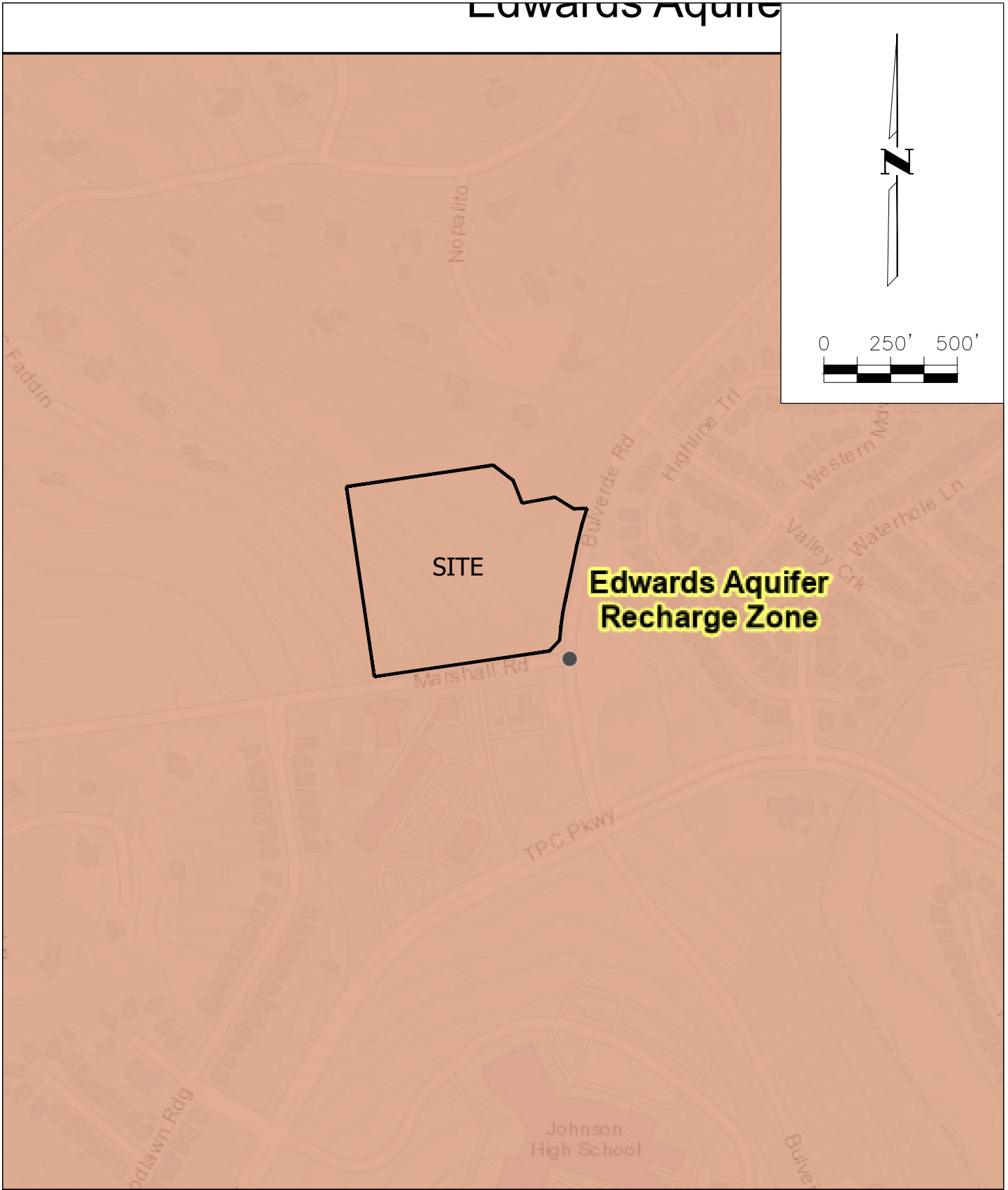



EXHIBIT B	BIG'S #212 C-STORE BULVERDE RD AND MARSHALL RD	EDWARDS AQUIFER RECHARGE ZONE MAP EXHIBIT	 11903 JONES MALTSBERGER RD., SUITE 102 SAN ANTONIO, TX 78216 TEL 210-774-5504 WWW.UPENGINEERING.COM TBPE F-17992 TBPLS F-10194606
---------------------	--	---	---

Attachment C

Project Description

Project Description

The project site consists of approximately 12.3 acres located at the intersection of the Summit Church Road (Previously Marshall Road) and Bulverde Rd. in the City of San Antonio ETJ. The site is currently undeveloped. The proposed development will be the development of a convenience store with fuel stations, driveways, and parking areas. Approximately 7.55 acres of undeveloped offsite runoff is conveyed onto the site from the west. A earthen drainage channel will be used to bypass all offsite runoff.

The proposed improvements for the site consist of a convenience store with fuel stations, driveways, and parking areas. The proposed impervious cover will consist of parking and associated access drives. Due to the SAWS Category letter the site will be limited to 15% impervious cover. A water quality pond and vegetative filter strips are proposed to reduce TSS exiting the site. A portion of the site lies within the 100-year floodplain area. Runoff from the site is ultimately conveyed to Mud Creek.

Geologic Assessment

In this Section:

TCEQ-0585

Geologic Assessment Form

Attachment A

Geologic Assessment Table

Attachment B

Soil Profile and Narrative of Soil Units

Attachment C

Stratigraphic Column

Attachment D

Narrative of Site Specific Geology

Site Geologic Map(s)



Geologic Assessment of the 12.3-Acre Marshall and Bulverde Roads Project, San Antonio, Bexar County, Texas

MAY 2021

(REVISED JUNE 2022)

PREPARED FOR

UP Engineering + Surveying

PREPARED BY

SWCA Environmental Consultants

Texas Board of Professional Geoscientists, Firm Registration No. 50159

This page intentionally left blank.

**GEOLOGIC ASSESSMENT
OF THE 12.3-ACRE MARSHALL AND BULVERDE ROADS PROJECT, SAN
ANTONIO,
BEXAR COUNTY, TEXAS**

Prepared for

UP Engineering + Surveying
11903 Jones Maltzberger Rd.,
Suite 102
San Antonio, TX 78216

Prepared by

Philip Pearce, P.G.
Kenadi Sutton

SWCA ENVIRONMENTAL CONSULTANTS
Texas Board of Professional Geoscientists, Firm Registration No. 50159
4949 N Loop 1604 W, Suite 235
San Antonio, TX 78249
www.swca.com

SWCA Project Number 66055

May 2021
(Revised June 2022)

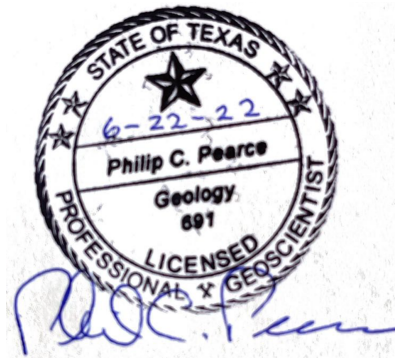

CONTENTS

1.0 Introduction	1
2.0 Methodology	1
3.0 Results	1
3.1 Site Overview.....	1
3.2 Geology.....	3
3.3 Soils.....	3
3.4 Site Hydrogeologic Assessment.....	3
4.0 References	4

FIGURES

Figure 1. Project Area location map.	2
---	---

APPENDICES

Appendix A Texas Commission on Environmental Quality (TCEQ) Forms

- Attachment A – Geologic Assessment Table
- Attachment B – Stratigraphic Column
- Attachment C – Narrative Description of Site Geology
- Attachment D – Site Geologic Map and Soils Map
- Attachment E – Photographic Documentation

Appendix B: Site Photographs

This page intentionally left blank.

1 INTRODUCTION

This narrative Geologic Assessment accompanies the Texas Commission on Environmental Quality (TCEQ) Geologic Assessment form TCEQ-0585 completed of a 12.3-acre tract, and a portion of a proposed off-site sanitary sewer line, located northwest of the intersection of Bulverde Road and Marshall Road (Project Site) in San Antonio, northern Bexar County, Texas (Figure 1).

2 METHODOLOGY

An SWCA scientist conducted field surveys on 5 April and 11 November 2021, and 14 and 22 June 2022. The pedestrian survey was completed by walking parallel transects spaced approximately 50 feet apart as directed by the TCEQ in the Instructions to Geologists for Geologic Assessments on the Edwards Aquifer Recharge/Transition Zones (Rev. 10-01-04). Closer spacing was used where vegetation inhibited clear observation. The SWCA scientist carefully examined all potential karst features, including depressions, holes, and animal burrows, for subsurface extent evidence. SWCA used several techniques for this effort, including probing with a digging implement to determine the thickness and consistency of fill material and feeling for air flow which may indicate the presence of a sub-surface void space. Other techniques included recording notable feature site characteristics such as vegetation types or a semi-circular burrow mound produced by small mammal activity.

3 RESULTS

3.1 Site Overview

The Project Site lies within the Edwards Aquifer Recharge Zone (TCEQ 2020). Topography generally slopes to the east towards Elm Waterhole Creek, with elevations ranging from approximately 1,120 to 1,060 feet above mean sea level.

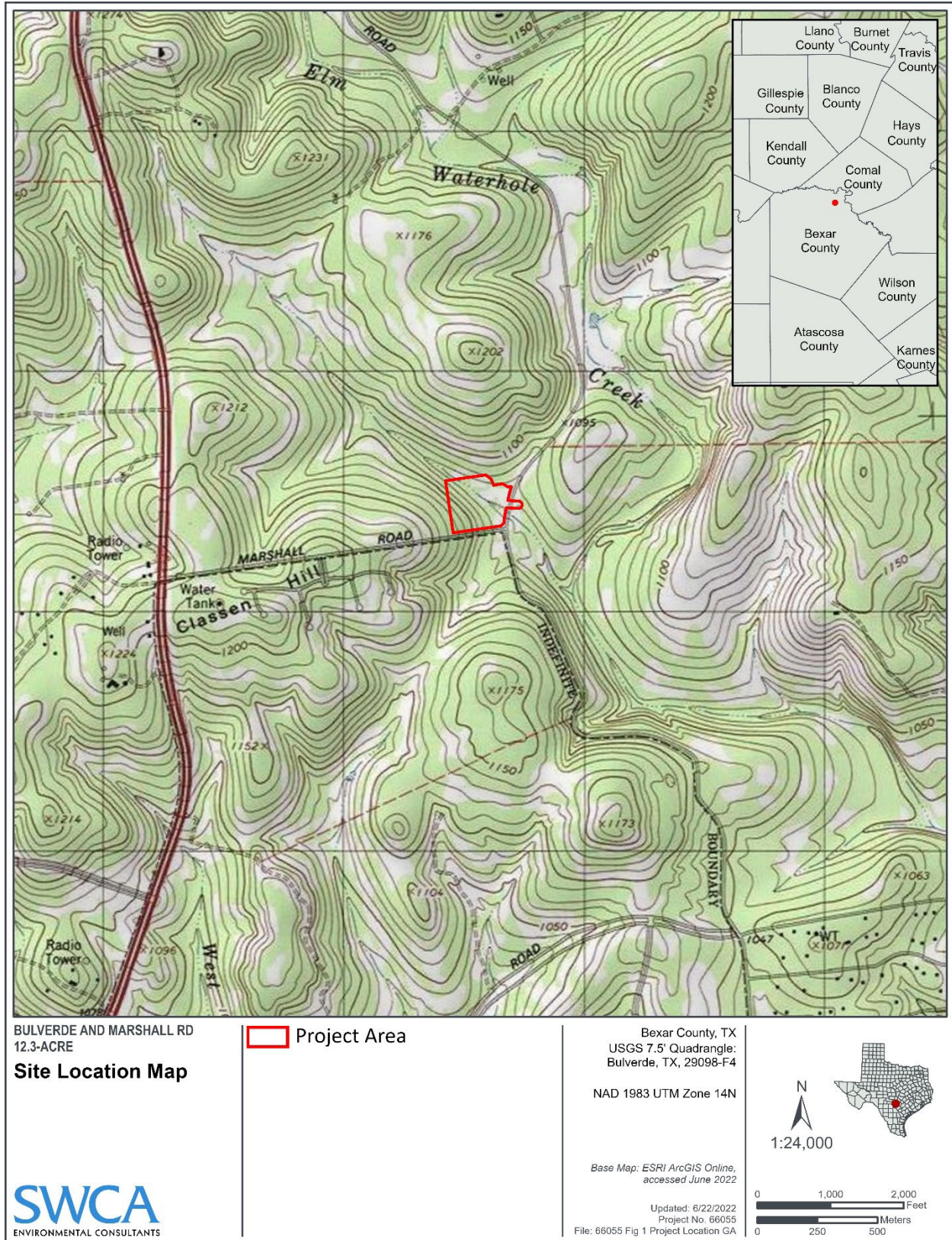

Figure 1. Project Site location map.

3.2 Geology

The Project Site is underlain by the Kainer Formation (Blome 2005) (Attachment D). The geology of the Project Site has been mapped most recently at a useful scale by Blome (2005) and SWCA finds this interpretation of the geology to be generally accurate. A Stratigraphic Column is included as Attachment B within Appendix A.

The Project Site occurs along the Balcones Fault Zone (BFZ) within the Edwards Aquifer Recharge Zone. Structural down-warping occurred with the Gulf of Mexico's ancestral formation during the middle Tertiary. The earth's crust was stretched in response and the BFZ formed along a zone of weakness, which currently marks the boundary between the Edwards Plateau and the Gulf Coastal Plain in central Texas. This zone is characterized by a series of northeast trending, predominantly normal, nearly vertical, en echelon faults. No faults cross the Project Site (Blome 2005).

The Project Site is within the Edwards Aquifer Recharge Zone (EARZ). Recharge into the Edwards Aquifer primarily occurs in areas where the Edwards Group and Georgetown Formation are exposed at the surface. Most recharge is from direct infiltration via precipitation and streamflow loss. Recharge occurs predominantly along secondary porosity features such as faults, fractures, and karst features (caves, solution cavities, sinkholes, etc.). Karst features are commonly formed along joints, fractures, and bedding plane surfaces in the Edwards Group and Georgetown Formation.

3.3 Soils

The Natural Resources Conservation Service (NRCS) identifies two soil unit within the Project Area (NRCS 2022).

- Eckrant very cobbly clay, 5 to 15 percent slopes (TaC)
- Eckrant cobbly clay, 1 to 8 percent slopes (TaD)

The TaC and TaD soil types are considered in the "D" hydrologic soil group classification, which have a very slow infiltration rate when thoroughly wet. A map of the Project Site displaying soil units is included in Attachment D.

3.4 Site Hydrogeologic Assessment

SWCA did not identify any geologic or manmade features on the Project Site, other than an existing sanitary sewer line that will be tied into (Feature S-1). The overall potential for fluid migration to the Edwards Aquifer for the site appears relatively low compared to background infiltration rates due to the presence of no geologic recharge features.

Feature S-1 is an existing sanitary sewer line that will be tied into. Typically trenches for sanitary sewer lines are cut into bedrock, and the trenches are backfilled with a mixture of fine and coarse material, which might have a greater probability for rapid infiltration than the surrounding undisturbed areas. Therefore, the probability of rapid infiltration is intermediate.

4 REFERENCES

Blome, C.D., Faith, J.R., Pedraza, D.E., Ozuna, G.B., Cole, J.C., Clark, A.K., Small, T.A., and Morris, R.R. 2005. Geologic Map of the Edwards Aquifer Recharge Zone, South-central Texas. U.S. Geological Survey, Scientific Investigations Map SIM-2873. 1:200,000.

Natural Resource Conservation Service (NRCS). 2022. Soil Survey Staff, Natural Resources Conservation Service, United States Department of Agriculture. Web Soil Survey. Available at: <http://websoilsurvey.nrcs.usda.gov/>. Accessed June 2022.

Texas Commission on Environmental Quality. 2022. Edwards Aquifer Viewer v3.8. Available at: <http://tceq.maps.arcgis.com/apps/webappviewer/index.html?id=2e5afa3ba8144c30a49d3dc1ab49edcd>. Accessed June 2022.

Texas Water Development Board (TWDB). 2022. Water Data Interactive, interactive GIS database. Available at: <http://www2.twdb.texas.gov/apps/waterdatainteractive/groundwaterdataviewer>. Accessed June 2022.

This page intentionally left blank.

APPENDIX A

Texas Commission on Environmental Quality (TCEQ) Forms

Geologic Assessment

Texas Commission on Environmental Quality

For Regulated Activities on The Edwards Aquifer Recharge/transition Zones and Relating to 30 TAC §213.5(b)(3), Effective June 1, 1999

To ensure that the application is administratively complete, confirm that all fields in the form are complete, verify that all requested information is provided, consistently reference the same site and contact person in all forms in the application, and ensure forms are signed by the appropriate party.

Note: Including all the information requested in the form and attachments contributes to more streamlined technical reviews.

Signature

To the best of my knowledge, the responses to this form accurately reflect all information requested concerning the proposed regulated activities and methods to protect the Edwards Aquifer. My signature certifies that I am qualified as a geologist as defined by 30 TAC Chapter 213.

Print Name of Geologist: Philip Pearce, P.G.

Telephone: 210.877.2847

Date: June 22, 2022

Fax: 210.877.2848

Representing: SWCA Environmental Consultants- TBPG No. 50159 (Name of Company and TBPG or TBPE registration number)

Signature of Geologist:

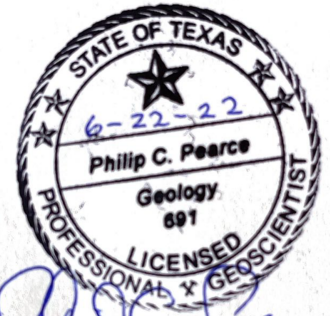

Regulated Entity Name: 12.3-acre Marshall and Bulverde Roads Project

Project Information

1. Date(s) Geologic Assessment was performed: April 5 and November 9, 2021, June 14 and 22, 2022

2. Type of Project:

WPAP

AST

SCS

UST

3. Location of Project:

Recharge Zone

Transition Zone

Contributing Zone within the Transition Zone

4. **Attachment A - Geologic Assessment Table.** Completed Geologic Assessment Table (Form TCEQ-0585-Table) is attached.
5. Soil cover on the project site is summarized in the table below and uses the SCS Hydrologic Soil Groups* (Urban Hydrology for Small Watersheds, Technical Release No. 55, Appendix A, Soil Conservation Service, 1986). If there is more than one soil type on the project site, show each soil type on the site Geologic Map or a separate soils map.

Table 1 - Soil Units, Infiltration Characteristics and Thickness

Soil Name	Group*	Thickness(feet)
Eckrant very cobbly clay, 5 to 15 percent slopes (TaC)	D	<2.0
Eckrant cobbly clay, 1 to 8 percent slopes (TaD)	D	<2.0

Soil Name	Group*	Thickness(feet)

** Soil Group Definitions (Abbreviated)*

- A. Soils having a high infiltration rate when thoroughly wetted.
- B. Soils having a moderate infiltration rate when thoroughly wetted.
- C. Soils having a slow infiltration rate when thoroughly wetted.
- D. Soils having a very slow infiltration rate when thoroughly wetted.

6. **Attachment B – Stratigraphic Column.** A stratigraphic column showing formations, members, and thicknesses is attached. The outcropping unit, if present, should be at the top of the stratigraphic column. Otherwise, the uppermost unit should be at the top of the stratigraphic column.
7. **Attachment C – Site Geology.** A narrative description of the site specific geology including any features identified in the Geologic Assessment Table, a discussion of the potential for fluid movement to the Edwards Aquifer, stratigraphy, structure(s), and karst characteristics is attached.
8. **Attachment D – Site Geologic Map(s).** The Site Geologic Map must be the same scale as the applicant's Site Plan. The minimum scale is 1": 400'
 Applicant's Site Plan Scale: 1" = 60'
 Site Geologic Map Scale: 1" = 60'
 Site Soils Map Scale (if more than 1 soil type): 1" = 416'
9. Method of collecting positional data:
 Global Positioning System (GPS) technology.

- Other method(s). Please describe method of data collection: _____
10. The project site and boundaries are clearly shown and labeled on the Site Geologic Map.
11. Surface geologic units are shown and labeled on the Site Geologic Map.
12. Geologic or manmade features were discovered on the project site during the field investigation. They are shown and labeled on the Site Geologic Map and are described in the attached Geologic Assessment Table.
- Geologic or manmade features were not discovered on the project site during the field investigation.
13. The Recharge Zone boundary is shown and labeled, if appropriate.
14. All known wells (test holes, water, oil, unplugged, capped and/or abandoned, etc.): If applicable, the information must agree with Item No. 20 of the WPAP Application Section.
- There are _____ (#) wells present on the project site and the locations are shown and labeled. (Check all of the following that apply.)
- The wells are not in use and have been properly abandoned.
- The wells are not in use and will be properly abandoned.
- The wells are in use and comply with 16 TAC Chapter 76.
- There are no wells or test holes of any kind known to exist on the project site.

Administrative Information

15. Submit one (1) original and one (1) copy of the application, plus additional copies as needed for each affected incorporated city, groundwater conservation district, and county in which the project will be located. The TCEQ will distribute the additional copies to these jurisdictions. The copies must be submitted to the appropriate regional office.

ATTACHMENT A

Geologic Assessment Table

ATTACHMENT B
Stratigraphic Column

Stratigraphic Column

Note: The shaded areas represent the lithology that outcrops on the property.¹

Upper Cretaceous	Upper Confining Units		Navarro and Taylor Groups, undivided; 600 feet thick		
			Austin Group; 130-150 feet thick		
			Eagle Ford Group; 30-50 feet thick		
			Buda Limestone; 40-50 feet thick		
			Del Rio Clay; 40-50 feet thick		
Lower Cretaceous	Edwards Aquifer	Edwards Group	I	Georgetown Formation 10-40 feet thick	
			II	Person Formation; 170-200 feet thick	
			III		Cyclic and Marine member, undivided
			IV		Leached and Collapsed member, undivided
			V	Regional Dense member	
			VI	Kainer Formation; 260-310 feet thick	
			VII		Grainstone member
			VIII		Kirschberg Evaporite member
		Dolomitic member			
	Lower Confining Units			Basal Nodular member	
		Upper member of Glen Rose Formation; 350-500 feet thick			

¹ Blome, C.D., Faith, J.R., Pdraza, D.E, Ozuna, G.B, Cole, J.C., Clark, A.K., Small, T.A., and Morris, R.R. 2005. Geologic map of the Edwards aquifer recharge zone, south-central-Texas. U.S. Geological Survey SIM-2873. Scale 1:200,000.

ATTACHMENT C

Narrative Description of Site Geology

PLEASE REFER TO SECTION 3.0 OF THIS REPORT FOR GEOLOGIC NARRATIVE DESCRIPTION

ATTACHMENT D

Site Geologic and Soil Unit Maps



- Feature
- Project Area
- Geologic Unit**
- Kek - Kainer Formation

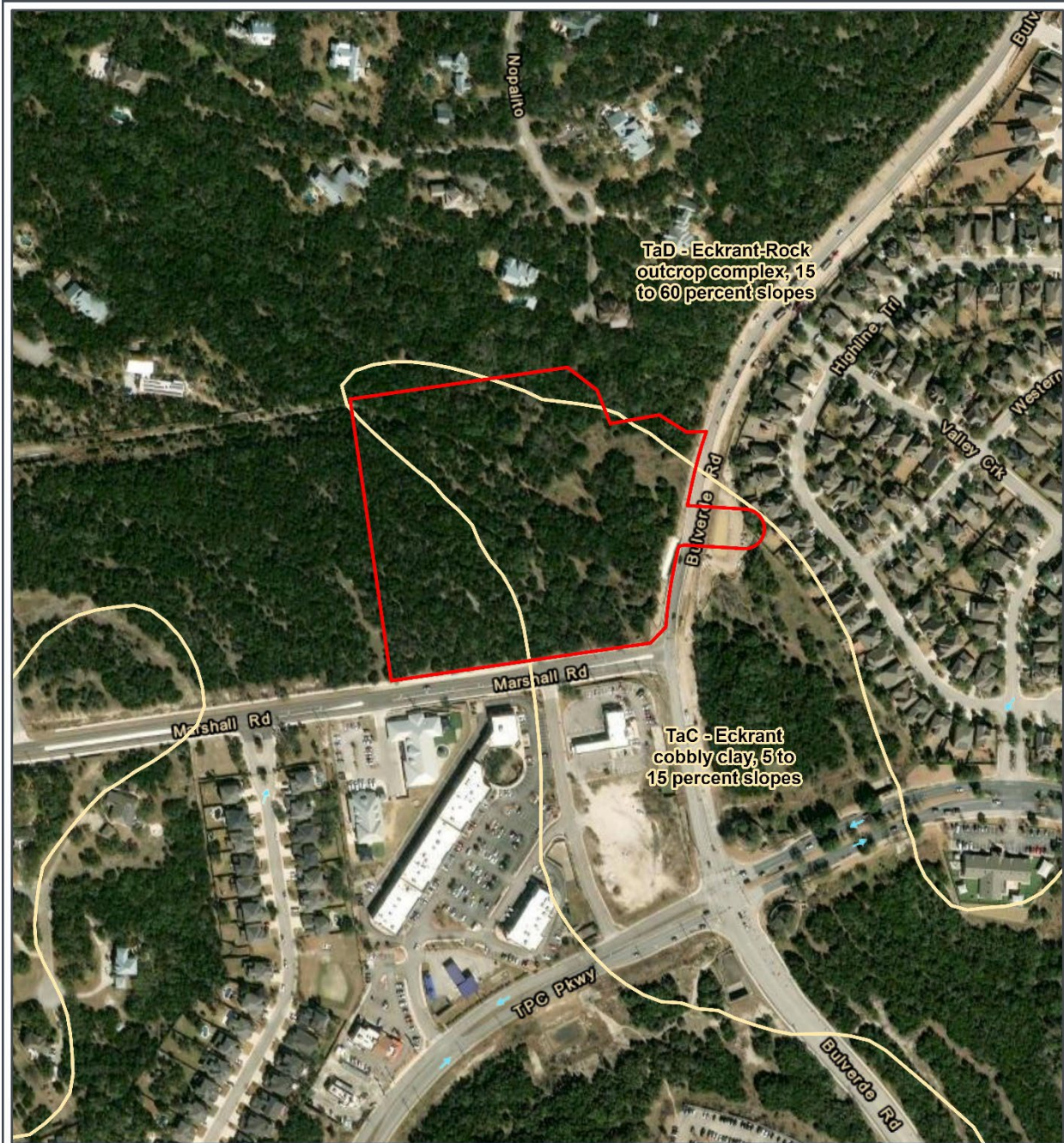

BULVERDE AND MARSHALL RD
12.3-ACRE

Soils Map

- Project Area
- Soils Unit



Bexar County, TX
USGS 7.5' Quadrangle:
Bulverde, TX, 29098-F4
NAD 1983 UTM Zone 14N

Base Map: ESRI ArcGIS Online,
accessed June 2022
Updated: 6/22/2022
Project No. 66055
File: 66055 Fig 3 Soils Map

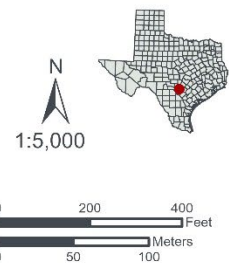

Water Pollution Abatement Plan Application Form

In this Section:

TCEQ-0584

Water Pollution Abatement Plan Application Form

Attachment A

Factors Affecting Water Quality

Attachment B

Volume and Character of Stormwater

Attachment C

Suitability Letter from Authorized Agent (if OSSF is proposed)

Attachment D

Exception to the Required Geologic Assessment (if requesting an exception)

Site Plan

Water Pollution Abatement Plan Application

Texas Commission on Environmental Quality

for Regulated Activities on the Edwards Aquifer Recharge Zone and Relating to 30 TAC §213.5(b), Effective June 1, 1999

To ensure that the application is administratively complete, confirm that all fields in the form are complete, verify that all requested information is provided, consistently reference the same site and contact person in all forms in the application, and ensure forms are signed by the appropriate party.

Note: Including all the information requested in the form and attachments contributes to more streamlined technical reviews.

Signature

To the best of my knowledge, the responses to this form accurately reflect all information requested concerning the proposed regulated activities and methods to protect the Edwards Aquifer. This **Water Pollution Abatement Plan Application Form** is hereby submitted for TCEQ review and Executive Director approval. The form was prepared by:

Print Name of Customer/Agent: Tyler Smith

Date: 03/24/2023

Signature of Customer/Agent:



Regulated Entity Name: _____

Regulated Entity Information

1. The type of project is:

- Residential: Number of Lots: _____
- Residential: Number of Living Unit Equivalents: _____
- Commercial
- Industrial
- Other: _____

2. Total site acreage (size of property): 12.30

3. Estimated projected population: N/A

4. The amount and type of impervious cover expected after construction are shown below:

Table 1 - Impervious Cover Table

Impervious Cover of Proposed Project	Sq. Ft.	Sq. Ft./Acre	Acres
Structures/Rooftops	7,400	÷ 43,560 =	0.17
Parking	45,308	÷ 43,560 =	1.04
Other paved surfaces	18,295	÷ 43,560 =	0.42
Total Impervious Cover	71,003	÷ 43,560 =	1.63

Total Impervious Cover 1.63 ÷ Total Acreage 12.30 X 100 = 13.25% Impervious Cover

5. **Attachment A - Factors Affecting Surface Water Quality.** A detailed description of all factors that could affect surface water and groundwater quality that addresses ultimate land use is attached.
6. Only inert materials as defined by 30 TAC §330.2 will be used as fill material.

For Road Projects Only

Complete questions 7 - 12 if this application is exclusively for a road project.

7. Type of project:

- TXDOT road project.
- County road or roads built to county specifications.
- City thoroughfare or roads to be dedicated to a municipality.
- Street or road providing access to private driveways.

8. Type of pavement or road surface to be used:

- Concrete
- Asphaltic concrete pavement
- Other: _____

9. Length of Right of Way (R.O.W.): _____ feet.

Width of R.O.W.: _____ feet.

L x W = _____ Ft² ÷ 43,560 Ft²/Acre = _____ acres.

10. Length of pavement area: _____ feet.

Width of pavement area: _____ feet.

L x W = _____ Ft² ÷ 43,560 Ft²/Acre = _____ acres.

Pavement area _____ acres ÷ R.O.W. area _____ acres x 100 = _____% impervious cover.

11. A rest stop will be included in this project.
- A rest stop will not be included in this project.

12. Maintenance and repair of existing roadways that do not require approval from the TCEQ Executive Director. Modifications to existing roadways such as widening roads/adding shoulders totaling more than one-half (1/2) the width of one (1) existing lane require prior approval from the TCEQ.

Stormwater to be generated by the Proposed Project

13. **Attachment B - Volume and Character of Stormwater.** A detailed description of the volume (quantity) and character (quality) of the stormwater runoff which is expected to occur from the proposed project is attached. The estimates of stormwater runoff quality and quantity are based on the area and type of impervious cover. Include the runoff coefficient of the site for both pre-construction and post-construction conditions.

Wastewater to be generated by the Proposed Project

14. The character and volume of wastewater is shown below:

<u>100</u> % Domestic	<u>1,125</u> Gallons/day
<u> </u> % Industrial	<u> </u> Gallons/day
<u> </u> % Commingled	<u> </u> Gallons/day
TOTAL gallons/day <u> </u>	

15. Wastewater will be disposed of by:

On-Site Sewage Facility (OSSF/Septic Tank):

Attachment C - Suitability Letter from Authorized Agent. An on-site sewage facility will be used to treat and dispose of the wastewater from this site. The appropriate licensing authority's (authorized agent) written approval is attached. It states that the land is suitable for the use of private sewage facilities and will meet or exceed the requirements for on-site sewage facilities as specified under 30 TAC Chapter 285 relating to On-site Sewage Facilities.

Each lot in this project/development is at least one (1) acre (43,560 square feet) in size. The system will be designed by a licensed professional engineer or registered sanitarian and installed by a licensed installer in compliance with 30 TAC Chapter 285.

Sewage Collection System (Sewer Lines):

Private service laterals from the wastewater generating facilities will be connected to an existing SCS.

Private service laterals from the wastewater generating facilities will be connected to a proposed SCS.

The SCS was previously submitted on .

The SCS was submitted with this application.

The SCS will be submitted at a later date. The owner is aware that the SCS may not be installed prior to Executive Director approval.

The sewage collection system will convey the wastewater to the _____ (name) Treatment Plant. The treatment facility is:

Existing.

Proposed.

16. All private service laterals will be inspected as required in 30 TAC §213.5.

Site Plan Requirements

Items 17 – 28 must be included on the Site Plan.

17. The Site Plan must have a minimum scale of 1" = 400'.

Site Plan Scale: 1" = 1:40 '.

18. 100-year floodplain boundaries:

Some part(s) of the project site is located within the 100-year floodplain. The floodplain is shown and labeled.

No part of the project site is located within the 100-year floodplain.

The 100-year floodplain boundaries are based on the following specific (including date of material) sources(s): _____

19. The layout of the development is shown with existing and finished contours at appropriate, but not greater than ten-foot contour intervals. Lots, recreation centers, buildings, roads, open space, etc. are shown on the plan.

The layout of the development is shown with existing contours at appropriate, but not greater than ten-foot intervals. Finished topographic contours will not differ from the existing topographic configuration and are not shown. Lots, recreation centers, buildings, roads, open space, etc. are shown on the site plan.

20. All known wells (oil, water, unplugged, capped and/or abandoned, test holes, etc.):

There are _____ (#) wells present on the project site and the locations are shown and labeled. (Check all of the following that apply)

The wells are not in use and have been properly abandoned.

The wells are not in use and will be properly abandoned.

The wells are in use and comply with 16 TAC §76.

There are no wells or test holes of any kind known to exist on the project site.

21. Geologic or manmade features which are on the site:

All sensitive geologic or manmade features identified in the Geologic Assessment are shown and labeled.

No sensitive geologic or manmade features were identified in the Geologic Assessment.

Attachment D - Exception to the Required Geologic Assessment. A request and justification for an exception to a portion of the Geologic Assessment is attached.

- 22. The drainage patterns and approximate slopes anticipated after major grading activities.
- 23. Areas of soil disturbance and areas which will not be disturbed.
- 24. Locations of major structural and nonstructural controls. These are the temporary and permanent best management practices.
- 25. Locations where soil stabilization practices are expected to occur.
- 26. Surface waters (including wetlands).
 N/A
- 27. Locations where stormwater discharges to surface water or sensitive features are to occur.
 There will be no discharges to surface water or sensitive features.
- 28. Legal boundaries of the site are shown.

Administrative Information

- 29. Submit one (1) original and one (1) copy of the application, plus additional copies as needed for each affected incorporated city, groundwater conservation district, and county in which the project will be located. The TCEQ will distribute the additional copies to these jurisdictions. The copies must be submitted to the appropriate regional office.
- 30. Any modification of this WPAP will require Executive Director approval, prior to construction, and may require submission of a revised application, with appropriate fees.

Attachment A

Factors Affecting Water Quality

Factors Affecting Water Quality

Potential sources of pollution that may be expected to affect the quality of storm water discharges from the site during construction include:

- Soil erosion due to clearing of the site.
- Oil, grease, fuel and hydraulic fluid contamination from construction equipment and vehicle drippings.
- Hydrocarbons from asphalt paving.
- Trash and litter from construction workers and material wrappings.
- Concrete truck washout.
- Tar, fertilizers, cleaning solvents, detergents, and petroleum-based products.

Potential sources of pollution that may be expected to affect the quality of stormwater discharges from the site after development include:

- Oil, grease, fuel and hydraulic fluid contamination from vehicle drippings.
- Dirt and dust from vehicles.
- Trash and litter.

Attachment B

Volume and Character of Stormwater

Volume and Character of Stormwater

The overall contributing drainage area for Halftime 1 is limited to the project area. The site's location at the intersection of two roadways lends itself to limiting the runoff conveyed onsite to only the project site, therefore eliminating potential runoff from the road rights-of-way. All upstream runoff is captured within an earthen drainage channel and bypass the development.

Under pre-project conditions, runoff on the site is generally conveyed from southwest to northeast across the property. The site is currently undeveloped with grass covering a majority of the site, and slopes ranging between 1% and 3% with a C-value of 0.55.

Due to the small project area, the Rational Method was used to calculate the stormwater runoff for the existing and proposed conditions of the site. The characteristics of the post-project stormwater runoff generated from the site will be influenced by non-point pollution. This will include oil and grease from paved areas, suspended solids, sedimentation, and at a minimum, nutrients for lawn care and possible pesticides and herbicides. Once discharged from the permanent and temporary BMPs, runoff will flow across pervious areas of rocky soils with native grasses prior to discharging into Mud Creek.

Attachment C

Suitability Letter from Authorized Agent

Suitability Letter from Authorized Agent

An OSSF is not proposed as part of this project; therefore, a Suitability Letter was not provided.

Attachment D

Exception to the Required Geologic Assessment

Exception to the Required Geologic Assessment

No exceptions to the required geologic assessment are proposed; therefore, this section is not applicable.

Site Plan

Temporary Stormwater Section

In this Section:

TCEQ-0602

Temporary Stormwater Section

Attachment A

Spill Response Actions

Attachment B

Potential Sources of Contamination

Attachment C

Sequence of Major Activities

Attachment D

Temporary Best Management Practices and Measures

Attachment E

Request to Temporarily Seal a Feature

Attachment F

Structural Practices

Attachment G

Drainage Area Map

Attachment H

Temporary Sediment Pond(s) Plans and Calculations

Attachment I

Inspection and Maintenance for BMPs

Attachment J

Schedule of Interim and Permanent Soil Stabilization Practices

Temporary Stormwater Section

Texas Commission on Environmental Quality

for Regulated Activities on the Edwards Aquifer Recharge Zone and Relating to 30 TAC §213.5(b)(4)(A), (B), (D)(I) and (G); Effective June 1, 1999

To ensure that the application is administratively complete, confirm that all fields in the form are complete, verify that all requested information is provided, consistently reference the same site and contact person in all forms in the application, and ensure forms are signed by the appropriate party.

Note: Including all the information requested in the form and attachments contributes to more streamlined technical reviews.

Signature

To the best of my knowledge, the responses to this form accurately reflect all information requested concerning the proposed regulated activities and methods to protect the Edwards Aquifer. This **Temporary Stormwater Section** is hereby submitted for TCEQ review and executive director approval. The application was prepared by:

Print Name of Customer/Agent: Karim Ali

Date: 03/24/22

Signature of Customer/Agent:

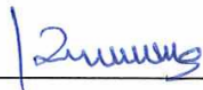

Regulated Entity Name: Halftime 1

Project Information

Potential Sources of Contamination

Examples: Fuel storage and use, chemical storage and use, use of asphaltic products, construction vehicles tracking onto public roads, and existing solid waste.

1. Fuels for construction equipment and hazardous substances which will be used during construction:

The following fuels and/or hazardous substances will be stored on the site: _____

These fuels and/or hazardous substances will be stored in:

Aboveground storage tanks with a cumulative storage capacity of less than 250 gallons will be stored on the site for less than one (1) year.

- Aboveground storage tanks with a cumulative storage capacity between 250 gallons and 499 gallons will be stored on the site for less than one (1) year.
- Aboveground storage tanks with a cumulative storage capacity of 500 gallons or more will be stored on the site. An Aboveground Storage Tank Facility Plan application must be submitted to the appropriate regional office of the TCEQ prior to moving the tanks onto the project.
- Fuels and hazardous substances will not be stored on the site.
- 2. **Attachment A - Spill Response Actions.** A site specific description of the measures to be taken to contain any spill of hydrocarbons or hazardous substances is attached.
- 3. **N/A** Temporary aboveground storage tank systems of 250 gallons or more cumulative storage capacity must be located a minimum horizontal distance of 150 feet from any domestic, industrial, irrigation, or public water supply well, or other sensitive feature.
- 4. **Attachment B - Potential Sources of Contamination.** A description of any activities or processes which may be a potential source of contamination affecting surface water quality is attached.

Sequence of Construction

- 5. **Attachment C - Sequence of Major Activities.** A description of the sequence of major activities which will disturb soils for major portions of the site (grubbing, excavation, grading, utilities, and infrastructure installation) is attached.
 - For each activity described, an estimate (in acres) of the total area of the site to be disturbed by each activity is given.
 - For each activity described, include a description of appropriate temporary control measures and the general timing (or sequence) during the construction process that the measures will be implemented.
- 6. Name the receiving water(s) at or near the site which will be disturbed or which will receive discharges from disturbed areas of the project: Mud Creek

Temporary Best Management Practices (TBMPs)

Erosion control examples: tree protection, interceptor swales, level spreaders, outlet stabilization, blankets or matting, mulch, and sod. Sediment control examples: stabilized construction exit, silt fence, filter dikes, rock berms, buffer strips, sediment traps, and sediment basins. Please refer to the Technical Guidance Manual for guidelines and specifications. All structural BMPs must be shown on the site plan.

- 7. **Attachment D – Temporary Best Management Practices and Measures.** TBMPs and measures will prevent pollution of surface water, groundwater, and stormwater. The construction-phase BMPs for erosion and sediment controls have been designed to retain sediment on site to the extent practicable. The following information is attached:

- A description of how BMPs and measures will prevent pollution of surface water, groundwater or stormwater that originates upgradient from the site and flows across the site.
 - A description of how BMPs and measures will prevent pollution of surface water or groundwater that originates on-site or flows off site, including pollution caused by contaminated stormwater runoff from the site.
 - A description of how BMPs and measures will prevent pollutants from entering surface streams, sensitive features, or the aquifer.
 - A description of how, to the maximum extent practicable, BMPs and measures will maintain flow to naturally-occurring sensitive features identified in either the geologic assessment, TCEQ inspections, or during excavation, blasting, or construction.
8. The temporary sealing of a naturally-occurring sensitive feature which accepts recharge to the Edwards Aquifer as a temporary pollution abatement measure during active construction should be avoided.
- Attachment E - Request to Temporarily Seal a Feature.** A request to temporarily seal a feature is attached. The request includes justification as to why no reasonable and practicable alternative exists for each feature.
 - There will be no temporary sealing of naturally-occurring sensitive features on the site.
9. **Attachment F - Structural Practices.** A description of the structural practices that will be used to divert flows away from exposed soils, to store flows, or to otherwise limit runoff discharge of pollutants from exposed areas of the site is attached. Placement of structural practices in floodplains has been avoided.
10. **Attachment G - Drainage Area Map.** A drainage area map supporting the following requirements is attached:
- For areas that will have more than 10 acres within a common drainage area disturbed at one time, a sediment basin will be provided.
 - For areas that will have more than 10 acres within a common drainage area disturbed at one time, a smaller sediment basin and/or sediment trap(s) will be used.
 - For areas that will have more than 10 acres within a common drainage area disturbed at one time, a sediment basin or other equivalent controls are not attainable, but other TBMPs and measures will be used in combination to protect down slope and side slope boundaries of the construction area.
 - There are no areas greater than 10 acres within a common drainage area that will be disturbed at one time. A smaller sediment basin and/or sediment trap(s) will be used in combination with other erosion and sediment controls within each disturbed drainage area.

- There are no areas greater than 10 acres within a common drainage area that will be disturbed at one time. Erosion and sediment controls other than sediment basins or sediment traps within each disturbed drainage area will be used.
11. **Attachment H - Temporary Sediment Pond(s) Plans and Calculations.** Temporary sediment pond or basin construction plans and design calculations for a proposed temporary BMP or measure have been prepared by or under the direct supervision of a Texas Licensed Professional Engineer. All construction plans and design information must be signed, sealed, and dated by the Texas Licensed Professional Engineer. Construction plans for the proposed temporary BMPs and measures are attached.
- N/A
12. **Attachment I - Inspection and Maintenance for BMPs.** A plan for the inspection of each temporary BMP(s) and measure(s) and for their timely maintenance, repairs, and, if necessary, retrofit is attached. A description of the documentation procedures, recordkeeping practices, and inspection frequency are included in the plan and are specific to the site and/or BMP.
13. All control measures must be properly selected, installed, and maintained in accordance with the manufacturer's specifications and good engineering practices. If periodic inspections by the applicant or the executive director, or other information indicate a control has been used inappropriately, or incorrectly, the applicant must replace or modify the control for site situations.
14. If sediment escapes the construction site, off-site accumulations of sediment must be removed at a frequency sufficient to minimize offsite impacts to water quality (e.g., fugitive sediment in street being washed into surface streams or sensitive features by the next rain).
15. Sediment must be removed from sediment traps or sedimentation ponds not later than when design capacity has been reduced by 50%. A permanent stake will be provided that can indicate when the sediment occupies 50% of the basin volume.
16. Litter, construction debris, and construction chemicals exposed to stormwater shall be prevented from becoming a pollutant source for stormwater discharges (e.g., screening outfalls, picked up daily).

Soil Stabilization Practices

Examples: establishment of temporary vegetation, establishment of permanent vegetation, mulching, geotextiles, sod stabilization, vegetative buffer strips, protection of trees, or preservation of mature vegetation.

17. **Attachment J - Schedule of Interim and Permanent Soil Stabilization Practices.** A schedule of the interim and permanent soil stabilization practices for the site is attached.

18. Records must be kept at the site of the dates when major grading activities occur, the dates when construction activities temporarily or permanently cease on a portion of the site, and the dates when stabilization measures are initiated.
19. Stabilization practices must be initiated as soon as practicable where construction activities have temporarily or permanently ceased.

Administrative Information

20. All structural controls will be inspected and maintained according to the submitted and approved operation and maintenance plan for the project.
21. If any geologic or manmade features, such as caves, faults, sinkholes, etc., are discovered, all regulated activities near the feature will be immediately suspended. The appropriate TCEQ Regional Office shall be immediately notified. Regulated activities must cease and not continue until the TCEQ has reviewed and approved the methods proposed to protect the aquifer from any adverse impacts.
22. Silt fences, diversion berms, and other temporary erosion and sediment controls will be constructed and maintained as appropriate to prevent pollutants from entering sensitive features discovered during construction.

Attachment A

Spill Response Actions

Spill Response Action

Spill Prevention and Control

The objective of this section is to describe measures to prevent or reduce the discharge of pollutants to drainage systems or watercourses from leaks and spills by reducing the chance for spills, stopping the source of spills, containing and cleaning up spills, properly disposing of spill materials, and training employees.

The following steps will help reduce the stormwater impacts of leaks and spills:

Education

1. Be aware that different materials pollute in different amounts. Make sure that each employee knows what a “significant spill” is for each material they use, and what is an appropriate response for “significant” and “insignificant” spills. Employees should also be aware of when spills must be reported to the TCEQ. Information available in 30 TAC 372.4 and 40 CFR 302.4.
2. Educate employees and subcontractors on potential dangers to humans and the environment from spills and leaks.
3. Hold regular meetings to discuss and reinforce appropriate disposal procedures (incorporate into regular safety meetings).
4. Establish a continuing education program to indoctrinate new employees.
5. Have contractor’s superintendent or representative oversee and enforce proper spill prevention and control measures.

General Measures

1. To the extent that the work can be accomplished safely, spills of oil, petroleum products, substances listed under 40 CFR parts 110, 117, and 302, and sanitary and septic wastes should be contained and cleaned up immediately.
2. Store hazardous materials and wastes in covered containers and protect from vandalism.
3. Place a stockpile of spill cleanup materials where it will be readily accessible.
4. Train employees in spill prevention and cleanup.
5. Designate responsible individuals to oversee and enforce control measures.
6. Spills should be covered and protected from stormwater run-on during rainfall to the extent that it doesn’t compromise cleanup activities.
7. Do not bury or wash spills with water.
8. Store and dispose of used cleanup materials, contaminated materials and recovered spill material that is no longer suitable for the intended purpose in conformance with the provisions in applicable BMPs.

9. Do not allow water used for cleaning and decontamination to enter storm drains or watercourses. Collect and dispose of contaminated water in accordance with applicable regulations.
10. Contain water overflow or minor water spillage and do not allow it to discharge into drainage facilities or watercourses.
11. Place Safety Data Sheets (SDS), as well as proper storage, cleanup, and spill reporting instructions for hazardous materials stored or used on the project site in an open, conspicuous, and accessible location.
12. Keep waste storage areas clean, well-organized, and equipment with ample cleanup supplies as appropriate for the materials being stored. Perimeter controls, containment structures, covers and liners should be repaired or replaced as needed to maintain proper function.

Cleanup

1. Clean up leaks and spills immediately.
2. Use a rag for small spills on paved surfaces, a damp mop for general cleanup, and absorbent material for larger spills. If the spilled material is hazardous, then the used cleanup materials are also hazardous and must be disposed of as hazardous waste.
3. Never hose down or bury dry material spills. Clean up as much of the material as possible and dispose of properly. See the waste management BMPs in this section for specific information.

Minor Spills

1. Minor spills typically involve small quantities of oil, gasoline, paint, etc. which can be controlled by the first responder at the discovery of the spill.
2. Use absorbent material on small spills rather than hosing down or burying the spill.
3. Absorbent material should be promptly removed and disposed of properly.
4. Follow the practice below for a minor spill:
 - a. Contain the spread of the spill.
 - b. Recover spilled material.
 - c. Clean the contaminated area and properly dispose of contaminated materials.

Semi-Significant Spills

Semi-significant spills still can be controlled by the first responder along with the aid of other personnel such as laborers and the foreman, etc. This response may require the cessation of all other activities.

Spills should be cleaned up immediately:

1. Contain spread of the spill.

2. Notify the project foreman immediately.
3. If the spill occurs on paved or impermeable surfaces, clean up using “dry” methods (absorbent materials, cat litter and/or rags). Contain the spill by encircling with absorbent materials and do not let the spill spread widely.
4. If the spill occurs in dirt areas, immediately contain the spill before constructing an earthen dike. Dig up and properly dispose of contaminated soil.
5. If the spill occurs during rain, cover spill with tarps or other material to prevent contaminating runoff.

Significant/Hazardous Spills

For significant or hazardous spills, that are in reportable quantities:

1. Notify the TCEQ by telephone as soon as possible and within 24 hours at 512-339-2929 (Austin) or 210-490-3096 (San Antonio) between 8 AM and 5 PM. After hours, contact the Environmental Release Hotline at 1-800-832-8224. It is the contractor’s responsibility to have all emergency phone numbers at the construction site.
2. For spills of federal reportable quantities, in conformance with the requirements in 40 CFR parts 110, 119, and 302, the contractor should notify the National Response Center at (800) 424-8802.
3. Notification should first be made by telephone and followed up with a written report.
4. The services of a spill contractor or a Haz-Mat team should be obtained immediately. Construction personnel should not attempt to clean up until the appropriate and qualified staffs have arrived at the job site.
5. Other agencies which may need to be consulted include, but are not limited to, the County Sheriff’s Office, Fire Departments, etc.

More information on spill rules and appropriate responses is available on the TCEQ website at:

<https://www.tceq.texas.gov/response/spills>

Vehicle and Equipment Preventative Maintenance

1. If maintenance must occur onsite, use a designated area and a secondary containment, located away from drainage courses, to prevent the run-on of stormwater and the runoff of spills.
2. Regularly inspect onsite vehicles and equipment for leaks and repair immediately.
3. Check incoming vehicles and equipment (including delivery trucks and employee/subcontractor vehicles) for leaking oil and fluids. Do not allow leaking vehicles or equipment onsite.

4. Always use secondary containment, such as a drain pan or drop cloth, to catch spills or leaks when removing or changing fluids.
5. Place drip pans or absorbent materials under paving equipment when not in use.
6. Use absorbent materials on small spills rather than hosing down or burying the spill. Remove absorbent materials promptly and dispose of properly.
7. Promptly transfer used fluids to the proper waste or recycle drums. Don't leave full drip pans or other open containers lying around.
8. Oil filters disposed of in trash cans or dumpsters can leak oil and pollute stormwater. Place the oil filter in a funnel over a waste oil-recycling drum to drain excess oil before disposal. Oil filters can also be recycled. Ask the oil supplier or recycler about recycling oil filters.
9. Store cracked batteries in a non-leaking secondary container. Do this with all cracked batteries even if you think all the acid has drained out. If you drop a battery, treat it as if it is cracked. Put it into the containment area until you are sure it is not leaking.

Vehicle and Equipment Fueling

1. If fueling must occur onsite, use designated areas, located away from drainage courses, to prevent the run-on of stormwater and the runoff of spills.
2. Discourage "topping off" of fuel tanks.
3. Always use secondary containment, such as a drain pan, when fueling to catch spills/leaks.

Attachment B

Potential Sources of Contamination

Potential Sources of Contamination

1. Oil, grease, fuel and hydraulic contamination from construction equipment and vehicle leakage.
Remedy: Lubrication and fueling will be performed in a designated area. This area will be monitored daily for contamination.
2. Miscellaneous trash and litter from construction works.
Remedy: Designated receptacles will be strategically located, and works will be directed to deposit trash there.
3. Construction debris.
Remedy: Debris will be collected weekly and deposited in bins for offsite disposal. Situations requiring immediate attention will be handled on a case-by-case basis.
4. Asphalt products.
Remedy: After placement of asphalt, emulsion or coatings, the contractor will be responsible for immediate cleanup should an unexpected rain occur. For the duration of the asphalt product curing time, the contractor will maintain standby personnel and equipment to control asphalt wash-off should an unexpected rain occur. The contractor will be instructed not to place asphalt products on the ground within 48 hours of a forecasted rain.
5. Tar, fertilizers, cleaning solvents, detergents, and petroleum-based products.
Remedy: The contractor will be responsible for immediate cleanup should an unexpected rain occur. Debris will be collected weekly and deposited in bins for offsite disposal. Situations requiring immediate attention will be handled on a case-by-case basis.

Attachment C

Sequence of Major Activities

Sequence of Major Activities

1. Install erosion and sedimentation controls (i.e. silt fences and stabilized construction entrances) as indicated on the approved construction plans.
2. Perform mass grading of the site (+/- 1.63 acres).
3. Install utilities.
4. Establish building foundation and pour concrete.
5. Install landscaping or hydromulch to disturbed areas.
6. Re-vegetate disturbed areas.
7. Remove temporary erosion and sedimentation controls.

Attachment D

Temporary Best Management Practices and Measures

Temporary Best Management Practices and Measures

The temporary Best Management Practices (BMP's) shall be installed as the first construction activity and will remain in place until all construction activities are complete and 70% of the vegetative cover has been established. Construction will be conducted in one phase, with a designated construction exit, a silt fence along the down gradient side of the tract, and tree protection for the undisturbed trees where applicable. The existing native grasses will be left undisturbed in areas not under construction. Rock berms will be placed where streets end at discharge points and flood plain crossings are to be installed. The temporary BMP's shall be installed according to details on the Water Pollution Abatement Plan detail sheet. The silt fences will be anchored six (6) inches into the soil and shall be monitored weekly for any failures of the silt fence or problems associated with silt build up. Buffer areas for recharge features shall be established prior to any construction on the site.

- a. To prevent pollution of surface water, groundwater or storm water that originates upgradient from the site and flows across the site, silt fencing will be placed along the down gradient side of the site and around indicated sensitive features.
- b. To prevent pollution of surface water or groundwater that originates on-site or flows off site, including pollution caused by contaminated storm water runoff from the site, silt fencing will be placed along the down gradient sides of the site and rock berms will be placed at the grade-to-drain areas at the ends of the streets (if applicable). A construction exit will also be installed at the entrance to the location and a storage and refueling area will be designated on the site for the unit.
- c. To prevent pollutants from entering surface streams, sensitive features, or the aquifer, the silt fence and rock berms mentioned in item b above will be installed. Once identified, sensitive features will be protected using hay bale dikes, sand bag berms or other methods acceptable to TCEQ.
- d. To maintain flow to naturally occurring sensitive features identified in the geologic assessment, inspections, or during construction, the hay bale dikes or sand bag berms mentioned in item c above will be installed. If a feature must be sealed, when possible the feature will be filled with boulders and gravel and capped with concrete.

Attachment E

Request to Temporarily Seal a Feature

Request to Temporarily Seal a Feature

Not Applicable

Attachment F

Structural Practices

STRUCTURAL PRACTICES

Silt fences will be used on site to trap sediments and pollutants from leaving the areas of construction. A rock berm will trap excess sediment and debris from travelling downstream and filter the storm water that passes through it.

Attachment G

Drainage Area Map

Drainage Area Map

The drainage area is not greater than 10 acres that will be disturbed at one time. A water quality pond and silt fences will be used to limit pollutant discharges before becoming concentrated channel flow. A rock berm will be used to further limit runoff discharge of pollutants from the site.

Attachment H

Temporary Sediment Pond(s) Plans and Calculations

Temporary Sediment Pond(s) Plans and Calculations

Not Applicable

Attachment I

Inspection and Maintenance for BMPs

INSPECTION AND MAINTENANCE FOR BMP'S

The temporary BMP's will be scheduled for inspection and repair once every week (7 days) and following any rainfall event that is greater than 0.5 inch. The contractor is responsible for logging all inspections, rainfall events and repairs. The contractor is also responsible for cleaning up any sediment that is released onto adjacent roadways after any rainfall event. The following forms shall be used for inspection and maintenance reports that are required to be kept on the project site by the contractor.

STORM WATER POLLUTION PREVENTION PLAN

INSPECTION AND MAINTENANCE REPORT

CHANGES REQUIRED TO THE POLLUTION PREVENTION PLAN:

REASONS FOR CHANGES:

INSPECTOR'S SIGNATURE: _____

DATE: _____

Silt Fence

Description

This item shall consist of providing and placing a filter fabric fence including maintenance of the fence, removal of accumulated silt and removal of the fence upon completion of the project.

Materials

(1) Fabric

- (a) General: The filter fabric shall be of nonwoven polypropylene, polyethylene or polyamide thermoplastic fibers with non-raveling edges. The fabric shall be non-biodegradable, inert to most soil chemicals, ultraviolet resistant, unaffected by moisture or other weather conditions, and permeable to water while retaining sediment. The filter fabric shall be supplied in rolls a minimum of 36 inches wide.
- (b) Physical Requirements: The fabric shall meet the following requirements when sampled and tested in accordance with the methods indicated.

Physical Properties	Method	Requirements
Fabric Weight(oz/sy)	TEX-616-J	4.5 minimum
Water Flow Rate (gal/sq. ft/minute)	TEX-616-J	40 maximum
Equivalent Opening Size: US	CW-02215, US Army	40 to 100
Standard sieve(number)	Corps of Engineers	
Mullen Burst Strength(psi)	ASTM D 3786	300 minimum
Ultraviolet Resistance; Strength retention (%)	ASTM D 1682	70 minimum

- (2) Posts: Posts shall be painted or galvanized steel Tee or Y-posts with anchor plates, not less than 4 feet in length with a minimum weight of 1.25 pounds per foot with a minimum Brinell Hardness of 140. Hangers shall be adequate to secure fence and fabric to posts. Posts and anchor plates shall conform to ASTM A 702.

- (3) Wire Fence: Wire fence shall be woven wire backing to support the fabric should be 2" x 4" welded wire, 12 gauge minimum.

Construction Methods

The silt fence fabric shall be securely attached to the posts and the wire support fence with the bottom 12 inches of the filter material buried in a trench a minimum of 6 inches deep and 6 inches wide to prevent sediment from passing under the fence. When the silt fence is constructed on impervious material, a 12-inch flap of fabric shall be extended upstream from the bottom of the silt fence and weighted to limit particulate loss. No horizontal joints will be allowed in the filter fabric. Vertical joints shall be overlapped a minimum of 12 inches with the ends sewn or otherwise securely tied.

The silt fence shall be a minimum of 24 inches high. Posts shall be embedded a minimum of 12 inches in the ground, placed a maximum of 8 feet apart and set on a slight angle toward the anticipated runoff source. When directed by the Engineer, posts shall be set at specified intervals to support concentrated loads.

The silt fence shall be repaired, replaced, and/or relocated when necessary or as directed by the Engineer. Accumulated silt shall be removed when it reaches a depth of 6 inches.

Measurement

The work performed, and the materials furnished under this item will be measured by the linear foot of "Silt Fence", complete in place.

Stabilized Construction Exit

Description

This item involves constructing a stabilized pad of crushed stone located at any point where traffic will be entering or leaving a construction site to or from a public right-of-way, street, alley, sidewalk or parking area. The purpose of a stabilized construction entrance is to reduce or eliminate the tracking or deposition of sediment onto public right-of-way.

Materials

Aggregate for construction shall conform to the following gradation:

8 inch	5 inch	2 inch
0	90-100	100

Construction Methods

All trees, brush, stumps, obstructions and other objectionable material shall be removed and disposed of so as not to interfere with the excavation and construction of the entrance as indicated. The entrance shall not drain onto the public right-of-way or leave the construction site.

When necessary, vehicle wheels shall be cleaned to remove sediment prior to entrance onto public right-of-way. When washing is required, it shall be done on an area stabilized with crushed stone which drains into an approved sediment trap or sediment basin. All sediment shall be prevented from entering any storm drain, ditch or watercourse through use of sand bags, gravel, boards, silt fence or other approved methods.

The entrance shall be maintained in a condition which will prevent tracking or disposition of sediment onto public right-of-way. This may require periodic top dressing with additional stone as conditions demand and repair and/or cleanout of any measures used to trap sediment. All sediment spilled, dropped, washed or tracked onto public right-of-way must be removed immediately.

Measurement

Acceptable work performed as prescribed in this item will be measured by unit of each stabilized construction entrance installed.

Rock Filter Dams

Description

This Item shall govern for the materials to be furnished and for the installation, maintenance and removal of rock filter dams of the dimensions shown on the plans. The rock filter dams shall be constructed at the locations shown on the plans and as directed by the Engineer. This Item will be used during construction to control erosion and sedimentation.

Materials

Unless otherwise specified, all aggregate used for the construction of the rock filter dams shall be hard, durable, clean, open-graded, and shall naturally resist crumbling, flaking and eroding. Aggregate gradation shall be 3 to 6 inches for rock filter dams Types 1, 2 and 4 and shall be 4 to 8 inches for Type 3.

The galvanized steel wire mesh and tie wires for Types 2 and 3 shall be a minimum 20 gauge unless specified otherwise on the plans.

For Type 4: Steel wire mesh shall utilize a double twisted hexagonal weave; mesh opening shall be a nominal 2.50" x 3.25"; steel wire for netting shall be 0.0866" (U.S. Gauge No. 13) minimum; steel wire for selvages and corners shall be 0.1063" (U.S. Gauge No. 110) minimum; and binding or tie wire shall be 0.0866" (U.S. Gauge No. 13) minimum.

Unless otherwise specified, the sandbag material shall be made of polypropylene, polyethylene or polyamide woven fabric, minimum unit weight four (4) ounces per square yard, Mullen burst strength exceeding 300 psi and ultraviolet stability exceeding 70 percent. The sandbag size shall be 24 to 30 inches in length, 16 to 18 inches in width, six (6) to eight (8) inches thick and weight 90 to 125 pounds. The sand shall be course grade.

Construction Methods

Trees, brush, stumps and other objectionable material shall be removed and disposed of as necessary so as not to interfere with the construction of the filter dams.

The filter dams shall be constructed according to the following criteria unless otherwise shown on the plans:

1. Type 1 (non-reinforced)
 - a. Height -
 - i. 18 inches minimum, measured vertically from existing ground to top of filter dam.
 - b. Top Width

- i. 2 feet minimum
 - c. Slopes
 - i. 2:1 maximum
- 2. Type 2 (reinforced)
 - a. Height
 - i. 18 inches minimum, measured vertically from existing ground to top of filter dam.
 - b. Top Width
 - i. 2 feet minimum
 - c. Slopes
 - i. 2:1 maximum

The aggregate shall be placed on the galvanized wire mesh to the lines, height and slopes specified without resulting in undue voids, and to the satisfaction of the Engineer. The mesh shall be folded at the upstream side over the aggregate and secured to itself on the downstream side. The mesh shall be attached to itself with wire ties, hog rings, or as directed by the Engineer.

- 3. Type 3 (reinforced)
 - a. Height
 - i. 36 inches minimum, measured vertically from existing ground to top of filter dam.
 - b. Top Width
 - i. 2 feet minimum
 - c. Slopes
 - i. 2:1 maximum

The aggregate shall be placed on the galvanized wire mesh to the lines, height and slopes specified without resulting in undue voids, and to the satisfaction of the Engineer. The mesh shall be folded at the upstream side over the aggregate and secured to itself on the downstream side. The mesh shall be attached to itself with wire ties, hog rings, or as directed by the Engineer.

4. Type 4 (Sack Gabions)

Sack gabions are supplied folded flat, packed in bundles. Single sacks shall be removed from the bundle, unfolded flat on the ground, and all kinks and bends stepped out.

For vertical filling, the two sides edge wires are connected by using the lacing wire in a “single loop – double loop” pattern on a 4” to 5” spacing. At one end, the “end lacing rod” must be pulled tight, wrapped around the end and twisted 4 times. At the filling end, the rod shall be pulled tight, cut, leaving about 6” length and twisted 4 times.

For horizontal filling, the sack shall be placed flat in a filling trough, filled with stone and then sides connected as described above. The ends shall be secured as described above.

Lifting and placing shall be accomplished by placing a No. 6 rebar (or equal) 5' long in the mesh, perpendicularly to the longitudinal axis and close to the knot of one end. Lifting should be made from the central point. Sack gabions shall conform to existing contours.

5. Type 5. Type 5 as shown on the plans.

Maintenance

The area upstream from the filter dams shall be maintained in a condition which will allow sediment to be removed following the runoff of a rainfall event. When the silt reaches a depth equal to $\frac{1}{3}$ the height of the dam or 1 foot, whichever is less, the Contractor shall remove the accumulated sediment and dispose of it at an approved site in a manner that will not contribute to additional siltation. The filter dams shall be reshaped as needed and as directed by the Engineer.

The filter dams shall be maintained in place until all upstream areas are adequately stabilized. When the special Specification, "Temporary Erosion, Sedimentation and Water Pollution Prevention and Control" is in the contract, stabilization shall be as described in Subarticle 4.C of that specification. The area beneath the filter dams and area damaged by the removal process shall then be stabilized by the Contractor using appropriate methods as approved by the Engineer.

Measurement

This Item will be measured by the linear foot or by the cubic yard, as shown on the plans. When measured by the linear foot, measurement will be along the centerline of the top of the dam. When measured by the cubic yard, measurement will be the volume for rock computed in its final position by the method of average end areas or in vehicles at the point of delivery. The measured volume will include sandbags, if they are used.

Each time the Engineer directs that the filter dam (or portions thereof) be removed or removed and replaced, it will be measured for payment.

Attachment J

Schedule of Interim and Permanent Soil Stabilization Practices



Schedule of Interim and Permanent Soil Stabilization Practices

Stabilization measures shall be initiated as soon as practicable in portions of the site where construction activities have temporarily or permanently ceased, but in no case more than 14 days after the construction activity in that portion of the site has temporarily or permanently ceased. Where the initiation of stabilization measures by the 14th day after construction activity temporary or permanently cease is precluded by weather conditions, stabilization measures shall be initiated as soon as practicable. Where construction activity on a portion of the site is temporarily ceased, and earth disturbing activities will be resumed within 21 days, temporary stabilization measures do not have to be initiated on that portion of site. In areas experiencing droughts where the initiation of stabilization measures by the 14th day after construction activity has temporarily or permanently ceased is precluded by seasonal arid conditions, stabilization measures shall be initiated as soon as practicable.

After all sanitary sewer construction has been completed, final stabilization of the construction area on all unpaved areas and areas not covered by permanent structures shall be completed by even distribution of 70% of the native background vegetative cover or equivalent permanent stabilization measures.

Revegetation will be necessary for soil stabilization of any offsite sanitary sewer construction. Seeding should be used for these areas. The specified seeding requirements are based on the seasonal San Antonio District Seeding Requirement as specified by Item 164 of the 2004 Texas Department of Transportation specifications Book.

Permanent Stormwater Section

In this Section:

TCEQ-0600

Permanent Stormwater Section

Attachment A

20% or Less Impervious Cover Waiver

Attachment B

BMPs for Upgradient Stormwater

Attachment C

BMPs for On-site Stormwater

Attachment D

BMPs for Surface Streams

Attachment E

Request to Seal Features

Attachment F

Construction Plans

Attachment G

Inspection, Maintenance, Repair and Retrofit Plan

Attachment H

Pilot-Scale Field Testing Plan

Attachment I

Measures for Minimizing Surface Stream Contamination

Permanent Stormwater Section

Texas Commission on Environmental Quality

for Regulated Activities on the Edwards Aquifer Recharge Zone and Relating to 30 TAC §213.5(b)(4)(C), (D)(li), (E), and (5), Effective June 1, 1999

To ensure that the application is administratively complete, confirm that all fields in the form are complete, verify that all requested information is provided, consistently reference the same site and contact person in all forms in the application, and ensure forms are signed by the appropriate party.

Note: Including all the information requested in the form and attachments contributes to more streamlined technical reviews.

Signature

To the best of my knowledge, the responses to this form accurately reflect all information requested concerning the proposed regulated activities and methods to protect the Edwards Aquifer. This **Permanent Stormwater Section** is hereby submitted for TCEQ review and executive director approval. The application was prepared by:

Print Name of Customer/Agent: Tyler Smith

Date: 03/24/2023

Signature of Customer/Agent



Regulated Entity Name: Halftime 1

Permanent Best Management Practices (BMPs)

Permanent best management practices and measures that will be used during and after construction is completed.

- Permanent BMPs and measures must be implemented to control the discharge of pollution from regulated activities after the completion of construction.
 N/A
- These practices and measures have been designed, and will be constructed, operated, and maintained to insure that 80% of the incremental increase in the annual mass loading of total suspended solids (TSS) from the site caused by the regulated activity is removed. These quantities have been calculated in accordance with technical guidance prepared or accepted by the executive director.
 The TCEQ Technical Guidance Manual (TGM) was used to design permanent BMPs and measures for this site.

A technical guidance other than the TCEQ TGM was used to design permanent BMPs and measures for this site. The complete citation for the technical guidance that was used is: _____

N/A

3. Owners must insure that permanent BMPs and measures are constructed and function as designed. A Texas Licensed Professional Engineer must certify in writing that the permanent BMPs or measures were constructed as designed. The certification letter must be submitted to the appropriate regional office within 30 days of site completion.

N/A

4. Where a site is used for low density single-family residential development and has 20 % or less impervious cover, other permanent BMPs are not required. This exemption from permanent BMPs must be recorded in the county deed records, with a notice that if the percent impervious cover increases above 20% or land use changes, the exemption for the whole site as described in the property boundaries required by 30 TAC §213.4(g) (relating to Application Processing and Approval), may no longer apply and the property owner must notify the appropriate regional office of these changes.

The site will be used for low density single-family residential development and has 20% or less impervious cover.

The site will be used for low density single-family residential development but has more than 20% impervious cover.

The site will not be used for low density single-family residential development.

5. The executive director may waive the requirement for other permanent BMPs for multi-family residential developments, schools, or small business sites where 20% or less impervious cover is used at the site. This exemption from permanent BMPs must be recorded in the county deed records, with a notice that if the percent impervious cover increases above 20% or land use changes, the exemption for the whole site as described in the property boundaries required by 30 TAC §213.4(g) (relating to Application Processing and Approval), may no longer apply and the property owner must notify the appropriate regional office of these changes.

Attachment A - 20% or Less Impervious Cover Waiver. The site will be used for multi-family residential developments, schools, or small business sites and has 20% or less impervious cover. A request to waive the requirements for other permanent BMPs and measures is attached.

The site will be used for multi-family residential developments, schools, or small business sites but has more than 20% impervious cover.

The site will not be used for multi-family residential developments, schools, or small business sites.

6. **Attachment B - BMPs for Upgradient Stormwater.**

- A description of the BMPs and measures that will be used to prevent pollution of surface water, groundwater, or stormwater that originates upgradient from the site and flows across the site is attached.
 - No surface water, groundwater or stormwater originates upgradient from the site and flows across the site, and an explanation is attached.
 - Permanent BMPs or measures are not required to prevent pollution of surface water, groundwater, or stormwater that originates upgradient from the site and flows across the site, and an explanation is attached.
7. **Attachment C - BMPs for On-site Stormwater.**
- A description of the BMPs and measures that will be used to prevent pollution of surface water or groundwater that originates on-site or flows off the site, including pollution caused by contaminated stormwater runoff from the site is attached.
 - Permanent BMPs or measures are not required to prevent pollution of surface water or groundwater that originates on-site or flows off the site, including pollution caused by contaminated stormwater runoff, and an explanation is attached.
8. **Attachment D - BMPs for Surface Streams.** A description of the BMPs and measures that prevent pollutants from entering surface streams, sensitive features, or the aquifer is attached. Each feature identified in the Geologic Assessment as sensitive has been addressed.
- N/A
9. The applicant understands that to the extent practicable, BMPs and measures must maintain flow to naturally occurring sensitive features identified in either the geologic assessment, executive director review, or during excavation, blasting, or construction.
- The permanent sealing of or diversion of flow from a naturally-occurring sensitive feature that accepts recharge to the Edwards Aquifer as a permanent pollution abatement measure has not been proposed.
 - Attachment E - Request to Seal Features.** A request to seal a naturally-occurring sensitive feature, that includes, for each feature, a justification as to why no reasonable and practicable alternative exists, is attached.
10. **Attachment F - Construction Plans.** All construction plans and design calculations for the proposed permanent BMP(s) and measures have been prepared by or under the direct supervision of a Texas Licensed Professional Engineer, and are signed, sealed, and dated. The plans are attached and, if applicable include:
- Design calculations (TSS removal calculations)
 - TCEQ construction notes
 - All geologic features
 - All proposed structural BMP(s) plans and specifications
- N/A

11. **Attachment G - Inspection, Maintenance, Repair and Retrofit Plan.** A plan for the inspection, maintenance, repairs, and, if necessary, retrofit of the permanent BMPs and measures is attached. The plan includes all of the following:
- Prepared and certified by the engineer designing the permanent BMPs and measures
 - Signed by the owner or responsible party
 - Procedures for documenting inspections, maintenance, repairs, and, if necessary retrofit
 - A discussion of record keeping procedures
- N/A
12. **Attachment H - Pilot-Scale Field Testing Plan.** Pilot studies for BMPs that are not recognized by the Executive Director require prior approval from the TCEQ. A plan for pilot-scale field testing is attached.
- N/A
13. **Attachment I -Measures for Minimizing Surface Stream Contamination.** A description of the measures that will be used to avoid or minimize surface stream contamination and changes in the way in which water enters a stream as a result of the construction and development is attached. The measures address increased stream flashing, the creation of stronger flows and in-stream velocities, and other in-stream effects caused by the regulated activity, which increase erosion that results in water quality degradation.
- N/A

Responsibility for Maintenance of Permanent BMP(s)

Responsibility for maintenance of best management practices and measures after construction is complete.

14. The applicant is responsible for maintaining the permanent BMPs after construction until such time as the maintenance obligation is either assumed in writing by another entity having ownership or control of the property (such as without limitation, an owner's association, a new property owner or lessee, a district, or municipality) or the ownership of the property is transferred to the entity. Such entity shall then be responsible for maintenance until another entity assumes such obligations in writing or ownership is transferred.
- N/A
15. A copy of the transfer of responsibility must be filed with the executive director at the appropriate regional office within 30 days of the transfer if the site is for use as a multiple single-family residential development, a multi-family residential development, or a non-residential development such as commercial, industrial, institutional, schools, and other sites where regulated activities occur.
- N/A

Attachment A

20% or Less Impervious Cover Waiver

20% or Less Impervious Cover Waiver

Not Applicable

Attachment B

BMPs for Upgradient Stormwater

BMPs for Upgradient Stormwater

No BMP for upgradient stormwater are being proposed from the site. Approximately 7.55 acres of undeveloped runoff is conveyed onto the site from the west. Due to the development of the site being limited to 15% of impervious cover +/-5.41 acres of offsite runoff bypasses the development and is discharged directly into the floodplain. The remaining +/- 2.41 acres of the site will bypass the development and subsequent detention pond due to a proposed earthen drainage channel.

Attachment C

BMPs for On-site Stormwater

BMPs for On-site Stormwater

One separate on-site partial sedimentation/filtration basin is designed to provide permanent on-site stormwater control; the basin is located near an existing low where storm water discharges and naturally drains from the site. The basin is designed to treat the required 80% of the difference in the total suspended solids in pre-and post-developed conditions in accordance with Edwards Aquifer Technical Guidance Manual RG-348 (revised July 2005). The flow into the pond will travel through paved parking lot areas and enter the pond via an underground drainage system. The first flush storm water enters the sedimentation chamber of the pond where heavy sediment settles. The sedimentation and filtration chambers are separated by gabion walls, which allow for free flow into the filtration chamber. Gravity forces the storm water in the filtration basin through a layer of sand and gravel into a pipe under the drain system, which filters out fine sediment from the flow. The drain system releases the treated storm water into a discharge pipe. Runoff that exceeds the first flush overtops the sedimentation basin weir and discharged outside of the sedimentation/filtration basin. Runoff leaving the basin (and bypass weir) will be discharged to an existing natural low in a non-erosive manner to minimize surface water contamination.

Vegetative filter strips are also proposed throughout the project site. Filter strips have been implemented on either side of the private access road, treating runoff that is unable to drain to the water quality basin. The filter strips will consist of both engineered, which will reduce the incremental increase in the site generated annual mass loading of total suspended solids by 80%.

See the attached calculations for details.

Attachment D

BMPs for Surface Streams

BMPs for Surface Streams

Not Applicable

Attachment E

Request to Seal Features

Request to Seal Features

Not Applicable

Attachment F

Construction Plans

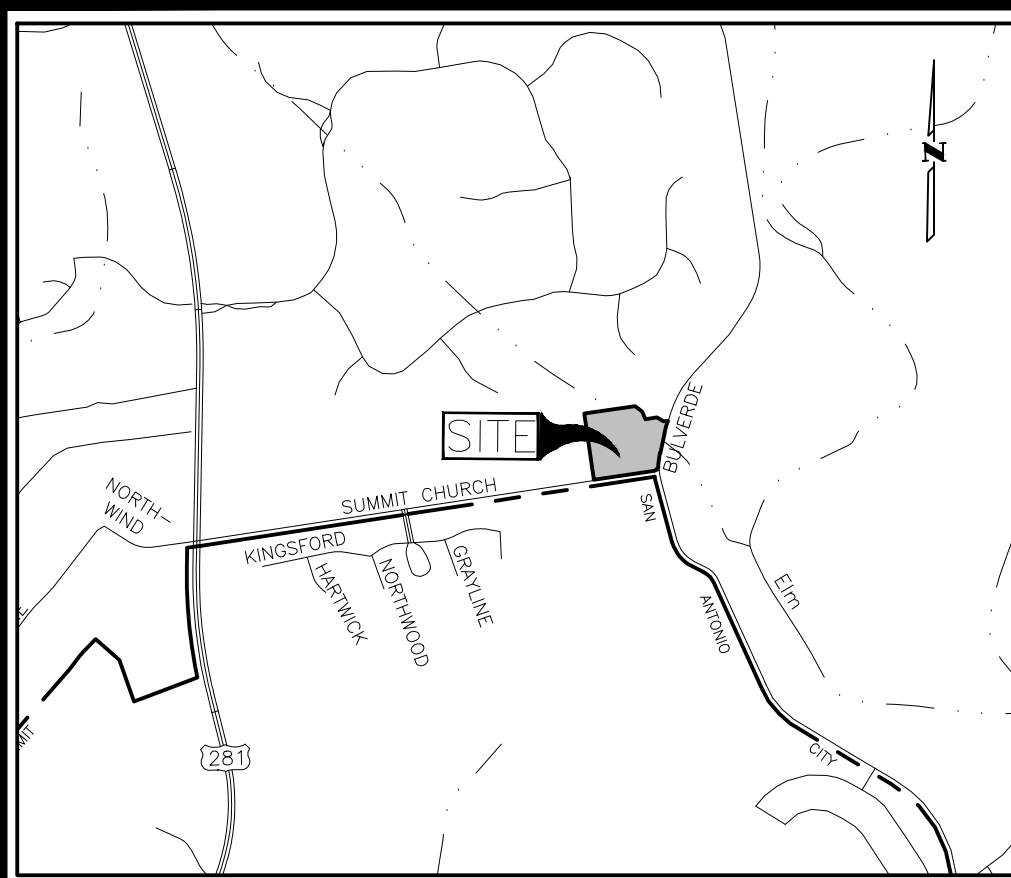

VICINITY MAP

NOT TO SCALE
Texas Commission on Environmental Quality
Water Pollution Abatement Plan
General Construction Notes

- A written notice of construction must be submitted to the TCEQ regional office at least 48 hours prior to the start of any regulated activities. This notice must include: the name of the approved project; the activity start date; and the contact information of the prime contractor.
- All contractors conducting regulated activities associated with this project must be provided with complete copies of the approved Water Pollution Abatement Plan and the TCEQ letter indicating the specific conditions of its approval. During the course of these regulated activities, the contractors are required to keep on-site copies of the approved plan and approval letter.
- If any sensitive feature(s) (caves, solution cavity, sink hole, etc.) is discovered during construction, all regulated activities near the sensitive feature must be suspended immediately. The appropriate TCEQ regional office must be immediately notified of any sensitive features encountered during construction. Construction activities may not be resumed until the TCEQ has reviewed and approved the appropriate protective measures in order to protect any sensitive feature and the Edwards Aquifer from potentially adverse impacts to water quality.
- No temporary or permanent hazardous substance storage tank shall be installed within 150 feet of a water supply source, distribution system, well, or sensitive feature.
- Prior to beginning any construction activity, all temporary erosion and sedimentation (E&S) control measures must be properly installed and maintained in accordance with the approved plans and manufacturers specifications. If inspections indicate a control has been used inappropriately, or incorrectly, the applicant must replace or modify the control for site situations. The controls must remain in place until the disturbed areas have been permanently stabilized.
- Any sediment that escapes the construction site must be collected and properly disposed of before the next rain event to ensure it is not washed into surface streams, sensitive features, etc.
- Sediment must be removed from sediment traps or sedimentation ponds not later than when it occupies 50% of the basin's design capacity.
- Litter, construction debris, and construction chemicals exposed to stormwater shall be prevented from discharging offsite.
- All spoils (excavated material) generated from the project site must be stored on-site with proper E&S controls. For storage or disposal of spoils at another site on the Edwards Aquifer Recharge Zone, the owner of the site must receive approval of a water pollution abatement plan for the placement of fill material or mass grading prior to the placement of spoils at the other site.
- If portions of the site will have a temporary or permanent cease in construction activity lasting longer than 14 days, soil stabilization in those areas shall be initiated as soon as possible prior to the 14th day of inactivity. If activity will resume prior to the 21st day, stabilization measures are not required. If drought conditions or inclement weather prevent action by the 14th day, stabilization measures shall be initiated as soon as possible.
- The following records shall be maintained and made available to the TCEQ upon request: the dates when major grading activities occur; the dates when construction activities temporarily or permanently cease on a portion of the site; and the dates when stabilization measures are initiated.
 - any physical or operational modification of any water pollution abatement structure(s), including but not limited to ponds, dams, berms, sewage treatment plants, and diversionary structures;
 - any change in the nature or character of the regulated activity from that which was originally approved or a change which would significantly impact the ability of the plan to prevent pollution of the Edwards Aquifer;
 - any development of land previously identified as undeveloped in the original water pollution abatement plan.

Austin Regional Office
12100 Park 35 Circle, Building A
Austin, Texas 78753-1808
Phone (512) 339-2929
Fax (512) 339-3795

San Antonio Regional Office
14250 Judson Road
San Antonio, Texas 78233-4480
Phone (210) 490-3096
Fax (210) 545-4329

THESE GENERAL CONSTRUCTION NOTES MUST BE INCLUDED ON THE CONSTRUCTION PLANS PROVIDED TO THE CONTRACTOR AND ALL SUBCONTRACTORS.

TSS Removal by Drainage Area					
Drainage Area	Acage	Impervious Cover (AC)	BMP	TSS Required (lbs)	TSS Removed (lbs)
AREA 1	6.83	0.07	NOT TREATED	57	0
AREA 2	2.87	0.07	NOT TREATED	57	0
AREA 3	2.08	1.21	WQ POND	987	1130
AREA 4	0.10	0.05	VFS	41	47
AREA 5	0.42	0.23	VFS	188	206
TOTAL	12.30	1.63		1330	1383

Actual Filter Basin area: 1,470 SF
Filtration Basin Volume: 4,410 CF
Actual Filter Basin area: 3,465
Sedimentation Basin Volume: 10,395 CF
TOTAL BASIN VOLUME: 14,805 CF

Texas Commission on Environmental Quality
TSS Removal Calculations 04-20-2009

Project Name: HALFTIME 1
Date Prepared: 8/15/2023

Additional information is provided for cells with a red triangle in the upper right corner. Place the cursor over the cell. Text shown in blue indicates location of instructions in the Technical Guidance Manual - RG-348. Characters shown in red are data entry fields. Characters shown in black (bold) are calculated fields. Changes to these fields will remove the equations used in the spreadsheet.

1. The Required Load Reduction for the total project. Calculations from RG-348 Pages 3-27 to 3-30

Page 3-29 Equation 3.3: $L_d = 27.2(A_u \times P)$
where:
 L_d Total TSS removed resulting from the proposed development = 85% of increased load
 A_u = Net increase in impervious area for the project
 P = Average annual precipitation, inches

Site Data: Determine Required Load Removal Based on the Entire Project
County = Bexar
Total project area included in plan = 12.30 acres
Predevelopment impervious area within the limits of the plan = 0.00 acres
Total post-development impervious area within the limits of the plan = 1.63 acres
Total post-development impervious cover fraction = 0.13
 L_d Total TSS removed = 1330 lbs

* The values entered in these fields should be for the total project area.

Number of drainage basins / outfalls areas leaving the plan area = 5

2. Drainage Basin Parameters (This information should be provided for each basin)
Drainage Basin/Outfall Area No. = 1
Total drainage basin/outfall area = 6.83 acres
Predevelopment impervious area within drainage basin/outfall area = 0.00 acres
Post-development impervious area within drainage basin/outfall area = 0.07 acres
Post-development impervious fraction within drainage basin/outfall area = 0.01
 L_d TSS removed = 57 lbs

* The values entered in these fields should be for the total project area.

Number of drainage basins / outfalls areas leaving the plan area = 5

3. Indicate the proposed BMP Code for this basin.

Proposed BMP = Vegetated / Turf Grass
Removal efficiency = 85 percent

4. Calculate Maximum TSS Load Removed for this Drainage Basin to be Retained BMP Type.
RG-348 Page 3-33 Equation 3.7: $L_d = (BMP \text{ efficiency}) \times P \times (A_u \times 0.43 + A_p \times 0.54)$
where:
 A_u = Total On-Site drainage area in the BMP catchment area
 A_p = Impervious area proposed in the BMP catchment area
 A_p = Permeous area remaining in the BMP catchment area
 L_d = TSS Load removed from this catchment area by the proposed BMP

where:
 A_u = 6.83 acres
 A_p = 0.00 acres
 A_p = 0.00 acres
 L_d = 208 lbs

5. Calculate Fraction of Annual Runoff to Treat the drainage basin / outfall area.
Desired L_d (lbs) = 57 lbs
 F = 1.00

* The values entered in these fields should be for the total project area.

Number of drainage basins / outfalls areas leaving the plan area = 5

2. Drainage Basin Parameters (This information should be provided for each basin)
Drainage Basin/Outfall Area No. = 2
Total drainage basin/outfall area = 2.87 acres
Predevelopment impervious area within drainage basin/outfall area = 0.00 acres
Post-development impervious area within drainage basin/outfall area = 0.07 acres
Post-development impervious fraction within drainage basin/outfall area = 0.02
 L_d TSS removed = 57 lbs

* The values entered in these fields should be for the total project area.

Number of drainage basins / outfalls areas leaving the plan area = 5

3. Indicate the proposed BMP Code for this basin.

Proposed BMP = Sand Filter
Removal efficiency = 89 percent

4. Calculate Maximum TSS Load Removed for this Drainage Basin to be Retained BMP Type.
RG-348 Page 3-33 Equation 3.7: $L_d = (BMP \text{ efficiency}) \times P \times (A_u \times 0.43 + A_p \times 0.54)$
where:
 A_u = Total On-Site drainage area in the BMP catchment area
 A_p = Impervious area proposed in the BMP catchment area
 A_p = Permeous area remaining in the BMP catchment area
 L_d = TSS Load removed from this catchment area by the proposed BMP

where:
 A_u = 2.87 acres
 A_p = 0.00 acres
 A_p = 0.00 acres
 L_d = 987 lbs

5. Calculate Fraction of Annual Runoff to Treat the drainage basin / outfall area.
Desired L_d (lbs) = 57 lbs
 F = 1.00

* The values entered in these fields should be for the total project area.

Number of drainage basins / outfalls areas leaving the plan area = 5

3. Indicate the proposed BMP Code for this basin.

Proposed BMP = Sand Filter
Removal efficiency = 89 percent

4. Calculate Maximum TSS Load Removed for this Drainage Basin to be Retained BMP Type.
RG-348 Page 3-33 Equation 3.7: $L_d = (BMP \text{ efficiency}) \times P \times (A_u \times 0.43 + A_p \times 0.54)$
where:
 A_u = Total On-Site drainage area in the BMP catchment area
 A_p = Impervious area proposed in the BMP catchment area
 A_p = Permeous area remaining in the BMP catchment area
 L_d = TSS Load removed from this catchment area by the proposed BMP

where:
 A_u = 2.08 acres
 A_p = 1.21 acres
 A_p = 0.87 acres
 L_d = 1130 lbs

5. Calculate Fraction of Annual Runoff to Treat the drainage basin / outfall area.
Desired L_d (lbs) = 1130 lbs
 F = 1.00

* The values entered in these fields should be for the total project area.

Number of drainage basins / outfalls areas leaving the plan area = 5

3. Indicate the proposed BMP Code for this basin.

Proposed BMP = Sand Filter
Removal efficiency = 89 percent

4. Calculate Maximum TSS Load Removed for this Drainage Basin to be Retained BMP Type.
RG-348 Page 3-33 Equation 3.7: $L_d = (BMP \text{ efficiency}) \times P \times (A_u \times 0.43 + A_p \times 0.54)$
where:
 A_u = Total On-Site drainage area in the BMP catchment area
 A_p = Impervious area proposed in the BMP catchment area
 A_p = Permeous area remaining in the BMP catchment area
 L_d = TSS Load removed from this catchment area by the proposed BMP

where:
 A_u = 0.10 acres
 A_p = 0.05 acres
 A_p = 0.05 acres
 L_d = 47 lbs

5. Calculate Fraction of Annual Runoff to Treat the drainage basin / outfall area.
Desired L_d (lbs) = 47 lbs
 F = 1.00

* The values entered in these fields should be for the total project area.

Number of drainage basins / outfalls areas leaving the plan area = 5

3. Indicate the proposed BMP Code for this basin.

Proposed BMP = Sand Filter
Removal efficiency = 89 percent

4. Calculate Maximum TSS Load Removed for this Drainage Basin to be Retained BMP Type.
RG-348 Page 3-33 Equation 3.7: $L_d = (BMP \text{ efficiency}) \times P \times (A_u \times 0.43 + A_p \times 0.54)$
where:
 A_u = Total On-Site drainage area in the BMP catchment area
 A_p = Impervious area proposed in the BMP catchment area
 A_p = Permeous area remaining in the BMP catchment area
 L_d = TSS Load removed from this catchment area by the proposed BMP

where:
 A_u = 0.42 acres
 A_p = 0.23 acres
 A_p = 0.23 acres
 L_d = 206 lbs

5. Calculate Fraction of Annual Runoff to Treat the drainage basin / outfall area.
Desired L_d (lbs) = 206 lbs
 F = 1.00

* The values entered in these fields should be for the total project area.

Number of drainage basins / outfalls areas leaving the plan area = 5

3. Indicate the proposed BMP Code for this basin.

Proposed BMP = Sand Filter
Removal efficiency = 89 percent

4. Calculate Maximum TSS Load Removed for this Drainage Basin to be Retained BMP Type.
RG-348 Page 3-33 Equation 3.7: $L_d = (BMP \text{ efficiency}) \times P \times (A_u \times 0.43 + A_p \times 0.54)$
where:
 A_u = Total On-Site drainage area in the BMP catchment area
 A_p = Impervious area proposed in the BMP catchment area
 A_p = Permeous area remaining in the BMP catchment area
 L_d = TSS Load removed from this catchment area by the proposed BMP

where:
 A_u = 0.10 acres
 A_p = 0.05 acres
 A_p = 0.05 acres
 L_d = 47 lbs

5. Calculate Fraction of Annual Runoff to Treat the drainage basin / outfall area.
Desired L_d (lbs) = 47 lbs
 F = 1.00

* The values entered in these fields should be for the total project area.

Number of drainage basins / outfalls areas leaving the plan area = 5

3. Indicate the proposed BMP Code for this basin.

Proposed BMP = Sand Filter
Removal efficiency = 89 percent

4. Calculate Maximum TSS Load Removed for this Drainage Basin to be Retained BMP Type.
RG-348 Page 3-33 Equation 3.7: $L_d = (BMP \text{ efficiency}) \times P \times (A_u \times 0.43 + A_p \times 0.54)$
where:
 A_u = Total On-Site drainage area in the BMP catchment area
 A_p = Impervious area proposed in the BMP catchment area
 A_p = Permeous area remaining in the BMP catchment area
 L_d = TSS Load removed from this catchment area by the proposed BMP

where:
 A_u = 0.42 acres
 A_p = 0.23 acres
 A_p = 0.23 acres
 L_d = 206 lbs

5. Calculate Fraction of Annual Runoff to Treat the drainage basin / outfall area.
Desired L_d (lbs) = 206 lbs
 F = 1.00

* The values entered in these fields should be for the total project area.

Number of drainage basins / outfalls areas leaving the plan area = 5

3. Indicate the proposed BMP Code for this basin.

Proposed BMP = Sand Filter
Removal efficiency = 89 percent

4. Calculate Maximum TSS Load Removed for this Drainage Basin to be Retained BMP Type.
RG-348 Page 3-33 Equation 3.7: $L_d = (BMP \text{ efficiency}) \times P \times (A_u \times 0.43 + A_p \times 0.54)$
where:
 A_u = Total On-Site drainage area in the BMP catchment area
 A_p = Impervious area proposed in the BMP catchment area
 A_p = Permeous area remaining in the BMP catchment area
 L_d = TSS Load removed from this catchment area by the proposed BMP

where:
 A_u = 0.10 acres
 A_p = 0.05 acres
 A_p = 0.05 acres
 L_d = 47 lbs

5. Calculate Fraction of Annual Runoff to Treat the drainage basin / outfall area.
Desired L_d (lbs) = 47 lbs
 F = 1.00

* The values entered in these fields should be for the total project area.

Number of drainage basins / outfalls areas leaving the plan area = 5

Texas Commission on Environmental Quality
TSS Removal Calculations 04-20-2009

Project Name: HALFTIME 1
Date Prepared: 8/15/2023

Additional information is provided for cells with a red triangle in the upper right corner. Place the cursor over the cell. Text shown in blue indicates location of instructions in the Technical Guidance Manual - RG-348. Characters shown in red are data entry fields. Characters shown in black (bold) are calculated fields. Changes to these fields will remove the equations used in the spreadsheet.

1. The Required Load Reduction for the total project. Calculations from RG-348 Pages 3-27 to 3-30

Page 3-29 Equation 3.3: $L_d = 27.2(A_u \times P)$
where:
 L_d Total TSS removed resulting from the proposed development = 85% of increased load
 A_u = Net increase in impervious area for the project
 P = Average annual precipitation, inches

Site Data: Determine Required Load Removal Based on the Entire Project
County = Bexar
Total project area included in plan = 12.30 acres
Predevelopment impervious area within the limits of the plan = 0.00 acres
Total post-development impervious area within the limits of the plan = 1.63 acres
Total post-development impervious cover fraction = 0.13
 L_d Total TSS removed = 1330 lbs

* The values entered in these fields should be for the total project area.

Number of drainage basins / outfalls areas leaving the plan area = 5

2. Drainage Basin Parameters (This information should be provided for each basin)
Drainage Basin/Outfall Area No. = 1
Total drainage basin/outfall area = 6.83 acres
Predevelopment impervious area within drainage basin/outfall area = 0.00 acres
Post-development impervious area within drainage basin/outfall area = 0.07 acres
Post-development impervious fraction within drainage basin/outfall area = 0.01
 L_d TSS removed = 57 lbs

* The values entered in these fields should be for the total project area.

Number of drainage basins / outfalls areas leaving the plan area = 5

3. Indicate the proposed BMP Code for this basin.

Proposed BMP = Vegetated / Turf Grass
Removal efficiency = 85 percent

4. Calculate Maximum TSS Load Removed for this Drainage Basin to be Retained BMP Type.
RG-348 Page 3-33 Equation 3.7: $L_d = (BMP \text{ efficiency}) \times P \times (A_u \times 0.43 + A_p \times 0.54)$
where:
 A_u = Total On-Site drainage area in the BMP catchment area
 A_p = Impervious area proposed in the BMP catchment area
 A_p = Permeous area remaining in the BMP catchment area
 L_d = TSS Load removed from this catchment area by the proposed BMP

where:
 A_u = 6.83 acres
 A_p = 0.00 acres
 A_p = 0.00 acres
 L_d = 208 lbs

5. Calculate Fraction of Annual Runoff to Treat the drainage basin / outfall area.
Desired L_d (lbs) = 57 lbs
 F = 1.00

* The values entered in these fields should be for the total project area.

Number of drainage basins / outfalls areas leaving the plan area = 5

2. Drainage Basin Parameters (This information should be provided for each basin)
Drainage Basin/Outfall Area No. = 2
Total drainage basin/outfall area = 2.87 acres
Predevelopment impervious area within drainage basin/outfall area = 0.00 acres
Post-development impervious area within drainage basin/outfall area = 0.07 acres
Post-development impervious fraction within drainage basin/outfall area = 0.02
 L_d TSS removed = 57 lbs

* The values entered in these fields should be for the total project area.

Number of drainage basins / outfalls areas leaving the plan area = 5

3. Indicate the proposed BMP Code for this basin.

Proposed BMP = Sand Filter
Removal efficiency = 89 percent

4. Calculate Maximum TSS Load Removed for this Drainage Basin to be Retained BMP Type.
RG-348 Page 3-33 Equation 3.7: $L_d = (BMP \text{ efficiency}) \times P \times (A_u \times 0.43 + A_p \times 0.54)$
where:
 A_u = Total On-Site drainage area in the BMP catchment area
 A_p = Impervious area proposed in the BMP catchment area
 A_p = Permeous area remaining in the BMP catchment area
 L_d = TSS Load removed from this catchment area by the proposed BMP

where:
 A_u = 2.87 acres
 A_p = 0.00 acres
 A_p = 0.00 acres
 L_d = 987 lbs

5. Calculate Fraction of Annual Runoff to Treat the drainage basin / outfall area.
Desired L_d (lbs) = 57 lbs
 F = 1.00

* The values entered in these fields should be for the total project area.

Number of drainage basins / outfalls areas leaving the plan area = 5

3. Indicate the proposed BMP Code for this basin.

Proposed BMP = Sand Filter
Removal efficiency = 89 percent

4. Calculate Maximum TSS Load Removed for this Drainage Basin to be Retained BMP Type.
RG-348 Page 3-33 Equation 3.7: $L_d = (BMP \text{ efficiency}) \times P \times (A_u \times 0.43 + A_p \times 0.54)$
where:
 A_u = Total On-Site drainage area in the BMP catchment area
 A_p = Impervious area proposed in the BMP catchment area
 A_p = Permeous area remaining in the BMP catchment area
 L_d = TSS Load removed from this catchment area by the proposed BMP

where:
 A_u = 2.08 acres
 A_p = 1.21 acres
 A_p = 0.87 acres
 L_d = 1130 lbs

5. Calculate Fraction of Annual Runoff to Treat the drainage basin / outfall area.
Desired L_d (lbs) = 1130 lbs
 F = 1.00

* The values entered in these fields should be for the total project area.

Number of drainage basins / outfalls areas leaving the plan area = 5

3. Indicate the proposed BMP Code for this basin.

Proposed BMP = Sand Filter
Removal efficiency = 89 percent

4. Calculate Maximum TSS Load Removed for this Drainage Basin to be Retained BMP Type.
RG-348 Page 3-33 Equation 3.7: $L_d = (BMP \text{ efficiency}) \times P \times (A_u \times 0.43 + A_p \times 0.54)$
where:
 A_u = Total On-Site drainage area in the BMP catchment area
 A_p = Impervious area proposed in the BMP catchment area
 A_p = Permeous area remaining in the BMP catchment area
 L_d = TSS Load removed from this catchment area by the proposed BMP

where:
 A_u = 0.10 acres
 A_p = 0.05 acres
 A_p = 0.05 acres
 L_d = 47 lbs

5. Calculate Fraction of Annual Runoff to Treat the drainage basin / outfall area.
Desired L_d (lbs) = 47 lbs
 F = 1.00

* The values entered in these fields should be for the total project area.

Number of drainage basins / outfalls areas leaving the plan area = 5

3. Indicate the proposed BMP Code for this basin.

Proposed BMP = Sand Filter
Removal efficiency = 89 percent

4. Calculate Maximum TSS Load Removed for this Drainage Basin to be Retained BMP Type.
RG-348 Page 3-33 Equation 3.7: $L_d = (BMP \text{ efficiency}) \times P \times (A_u \times 0.43 + A_p \times 0.54)$
where:
 A_u = Total On-Site drainage area in the BMP catchment area
 A_p = Impervious area proposed in the BMP catchment area
 A_p = Permeous area remaining in the BMP catchment area
 L_d = TSS Load removed from this catchment area by the proposed BMP

where:
 A_u = 0.42 acres
 A_p = 0.23 acres
 A_p = 0.23 acres
 L_d = 206 lbs

5. Calculate Fraction of Annual Runoff to Treat the drainage basin / outfall area.
Desired L_d (lbs) = 206 lbs
 F = 1.00

* The values entered in these fields should be for the total project area.

Number of drainage basins / outfalls areas leaving the plan area = 5

3. Indicate the proposed BMP Code for this basin.

Proposed BMP = Sand Filter
Removal efficiency = 89 percent

4. Calculate Maximum TSS Load Removed for this Drainage Basin to be Retained BMP Type.
RG-348 Page 3-33 Equation 3.7: $L_d = (BMP \text{ efficiency}) \times P \times (A_u \times 0.43 + A_p \times 0.54)$
where:
 A_u = Total On-Site drainage area in the BMP catchment area
 A_p = Impervious area proposed in the BMP catchment area
 A_p = Permeous area remaining in the BMP catchment area
 L_d = TSS Load removed from this catchment area by the proposed BMP

where:
 A_u = 0.10 acres
 A_p = 0.05 acres
 A_p = 0

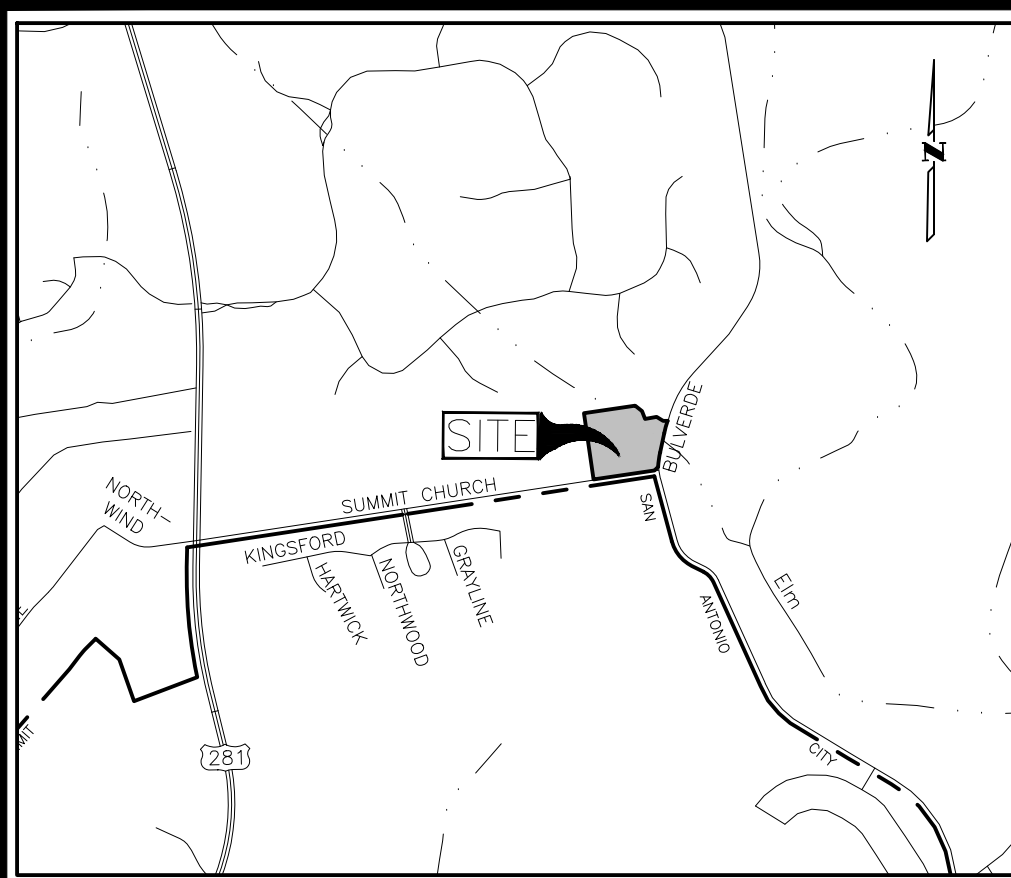

VICINITY MAP
NOT TO SCALE

NOTE:

- CONTRACTOR SHALL REFERENCE STRUCTURAL PLANS FOR WATER QUALITY POND WALL DESIGN.

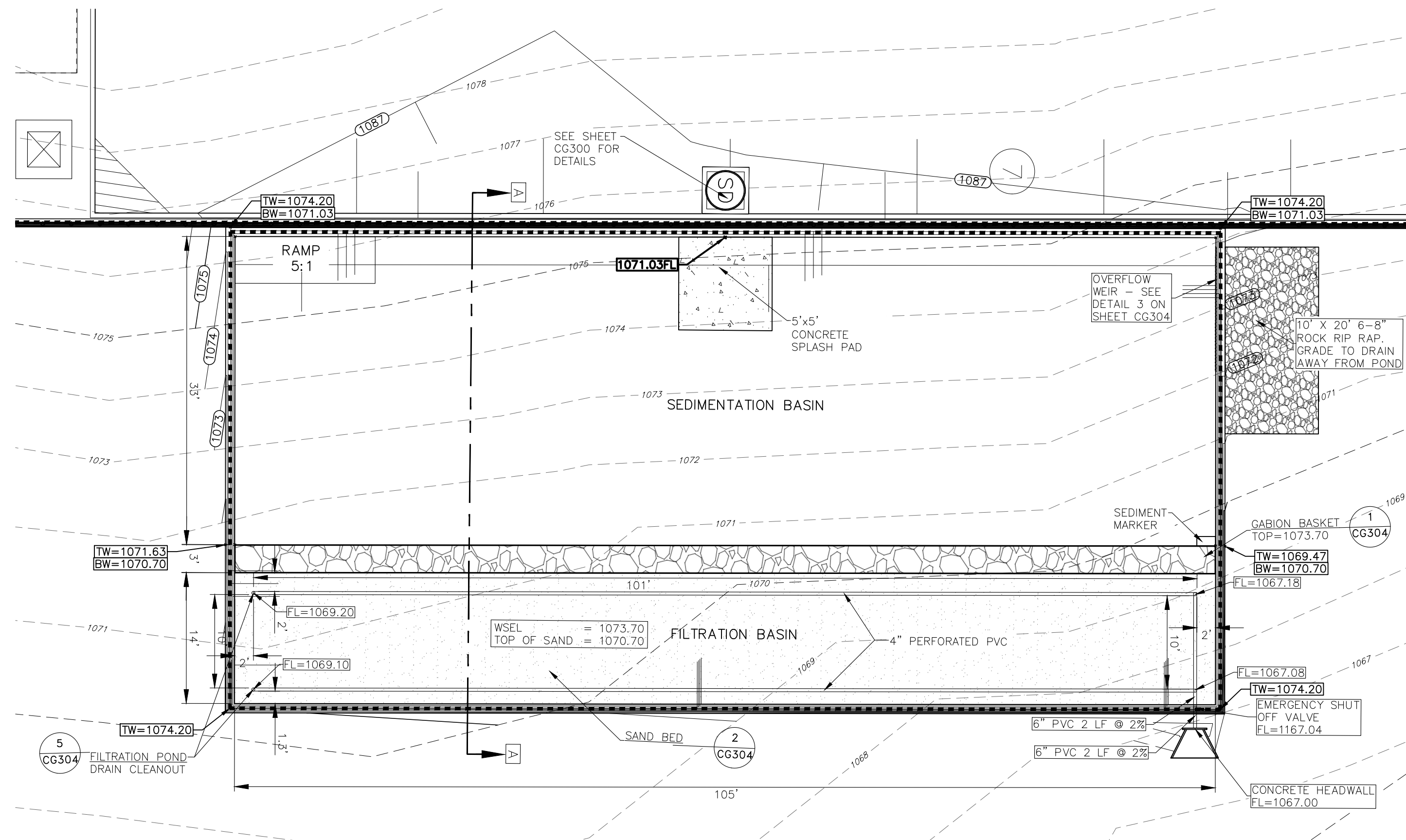

BMP 1 - WATER QUALITY POND
SCALE: 1" = 10'

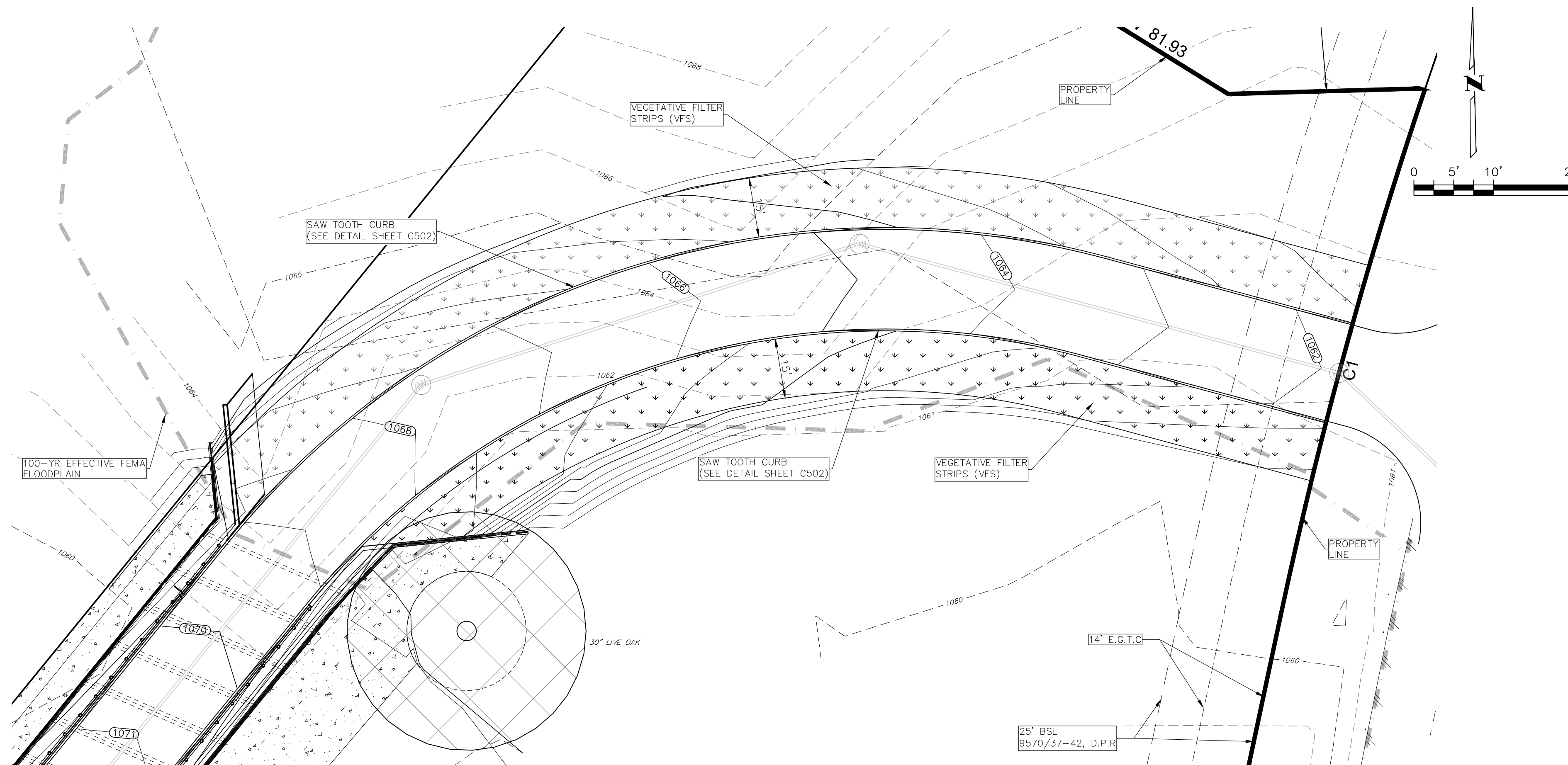

BMP 2 - VEGETATIVE FILTER STRIPS
SCALE: 1" = 20'

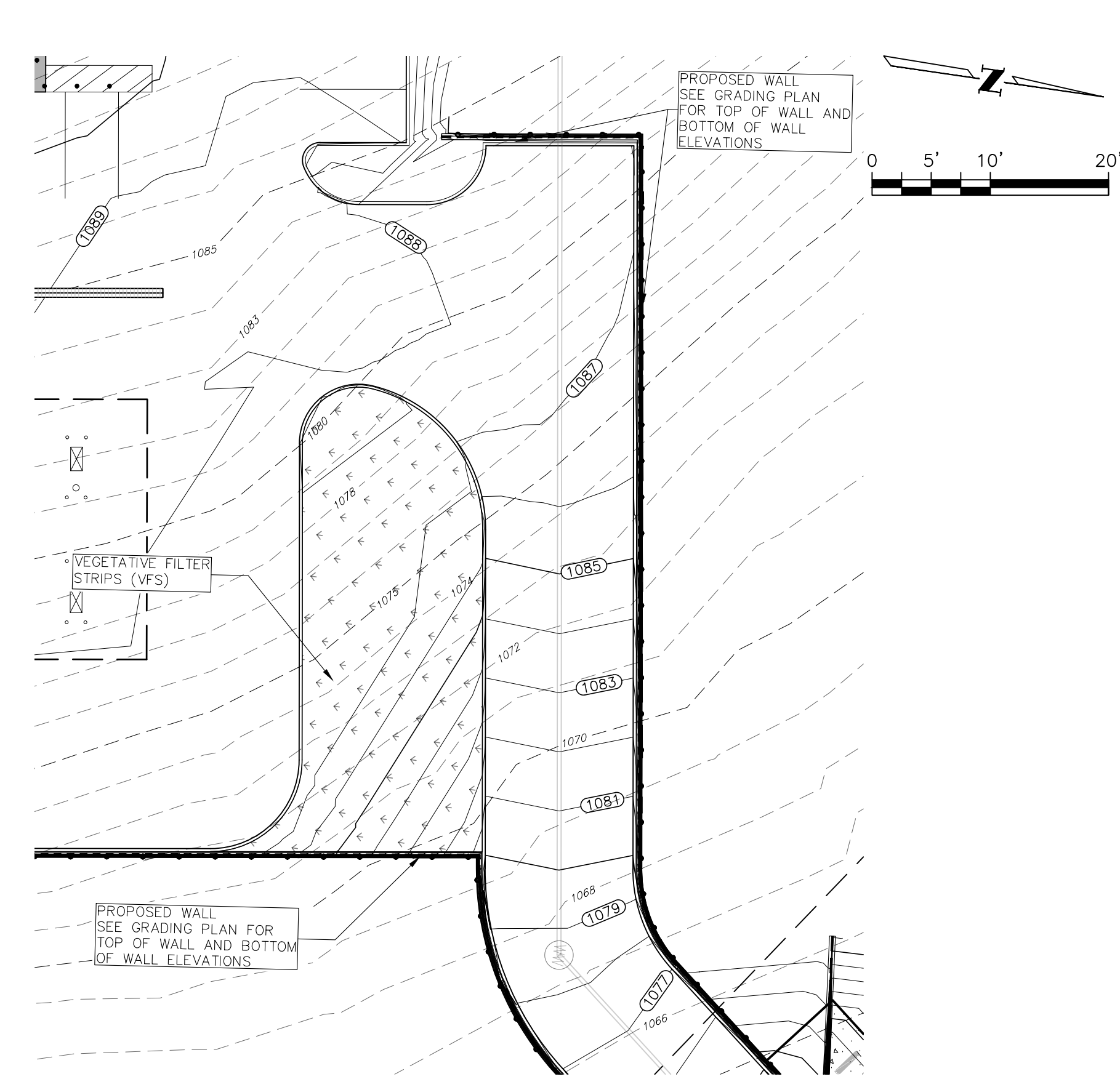

BMP 3 - VEGETATIVE FILTER STRIPS
SCALE: 1" = 20'

LEGEND

	BOUNDARY / RIGHT OF WAY LINE
	CONCRETE CURB
	LOW CURB
	EASEMENT / SETBACK LINE
	EXISTING CONTOUR
	PROPOSED CONTOUR
	PROPOSED ELEVATION
	EXISTING ELEVATION
	TOP OF WALL
	BOTTOM OF WALL
	FLOWLINE
	VEGETATIVE FILTER STRIPS (VFS)

UP
ENGINEERING
+ SURVEYING

11903 JONES MALSERBERGER, SUITE 102
SAN ANTONIO, TX 78216 TEL. 210-774-5504
WWW.UPENGINEERING.COM LICENSE # F-17392
TBFELS F-10194606

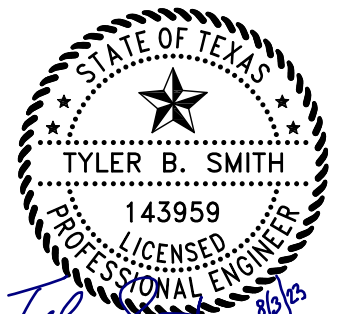

MARSHALL AND BULVERDE, LLC
7410 BLANCO RD.
SAN ANTONIO, TEXAS 78216

HALFTIME 1
3125 SUMMIT CHURCH ROAD, SAN ANTONIO, TX 78259

WATER QUALITY POND

REV	DATE	DESCRIPTION	BY

DESIGNED BY:

DRAFTED BY:

CHECKED BY:

SHEET

CG303

OF 21

Date: July 02, 2024, 10:58 AM, User: G. Tyler, Path: C:\Users\G. Tyler\OneDrive\Documents\Projects\CG303 - Water Quality Pond.dwg

GABION WALL NOTES

5949 DESCRIPTION
THIS ITEM SHALL INCLUDE FURNISHING, ASSEMBLING, FILLING, AND TYING ROCK-FILLED WIRE MESH COMPARTMENTED GABIONS AND REVET MATTRASSES IN ACCORDANCE WITH THE LINES, GRADES, AND DIMENSIONS SHOWN ON THE DRAWINGS OR OTHERWISE ESTABLISHED IN THE FIELD BY THE ENGINEER OR DESIGNATED REPRESENTATIVE.

5949.2 MATERIALS
(1) **GABION AND REVET MATTRESS WIRE**
GABION WIRE SHALL BE GALVANIZED STEEL CLASS 3 OR A COATING, SOFT TEMPER CONFORMING TO ASTM A 641, AND SHALL SPECIFICALLY MEET THE REQUIREMENTS GIVEN BELOW FOR GABIONS (12 GAUGE WIRE) AND/OR REVET MATTRASSES (13.5 WIRE GAUGE) AS CALLED OUT IN DRAWINGS. PVC COATING OF WIRE MAY BE FUSED ON OR EXTRUDED ON TO THE WIRE. GALVANIZATION OF WELDED WIRE SHALL BE PERFORMED EITHER BEFORE OR AFTER WELDING.

CHARACTERISTIC	GABIONS	REVE MATTRASSES
WIRE GAUGE	12 GAUGE	13.5 GAUGE
MAX. TENSILE STRENGTH (ASTM 641)	70,000 PSI (483 MPa)	75,000 PSI (517 MPa)
NOMINAL WIRE DIAMETER (ASTM A 641)	0.106 INCH (2.7 mm)	0.0866 INCH (2.2 mm)
MINIMUM DIAMETER (ASTM A 641, TABLE 3)	0.102 INCH (2.6 mm)	0.0826 INCH (2.9 mm)
GALVANIZED, ZINC (ASTM A 641, TABLE 1)	0.80 OZ/FT ² (245 GR/M)	0.70 OZ/FT ² (215 GR/M)

(2) **GABION MESH**
(A) **WOVEN MESH**
WOVEN MESH SHALL BE OF A UNIFORM NONRAVELING, DOUBLE TWIST HEXAGONAL PATTERN NOMINALLY OF DIMENSIONS 3.25 INCHES BY 4.5 INCHES (83 mm BY 114mm). SELVEDGE WIRE SHALL BE 10 GAUGE (NOMINAL DIAMETER OF 3.4 mm).
(B) **WELDED MESH**
MESH OPENING SHALL BE NOMINALLY 3 INCHES BY 3 INCHES (75 mm BY 75 mm). STRENGTH OF WELDS SHALL MEET THE REQUIREMENTS LISTED IN TABLE 2 FOR 13.5 GAUGE (2.2 mm) WIRE WHEN TESTED IN ACCORDANCE WITH SECTION 13.4 OF ASTM, A-974.

TYPE OF STRUCTURE	WIRE SIZE	MINIMUM AVERAGE
	(DIAMETER)	WELD SHEAR STRENGTH
GABIONS	12 (2.7)	475 lbf (2.10 kN)
	GUAGE (mm)	ENGLISH UNITS (SI UNITS)
REVE MATRESS	13.5 (2.2)	292 lbf (1.30 kN)

(C) **MANUFACTURING**
TWISTED WIRE MESH GABIONS SHALL BE MANUFACTURED IN CONFORMANCE WITH ASTM A-975, WHILE WELDED WIRE MESH GABIONS SHALL BE MANUFACTURED IN CONFORMANCE WITH ASTM A-974.

(3) **REVE MATTRASSES**

(A) **WOVEN MESH**
WOVEN MESH SHALL BE OF A UNIFORM NONRAVELING, DOUBLE TWIST HEXAGONAL PATTERN NOMINALLY OF DIMENSIONS 2.5 INCHES BY 3.25 INCHES (64 mm BY 83mm). SELVEDGE WIRE SHALL BE 12 GAUGE (NOMINAL DIAMETER OF 2.7 mm).
(B) **WELDED MESH**
MESH OPENING SHALL BE NOMINALLY 1.5 INCHES BY 3 INCHES (38 mm BY 76 mm). STRENGTH OF WELDS SHALL MEET THE REQUIREMENTS LISTED IN TABLE 2 FOR 13.5 GAUGE (2.2 mm) WIRE WHEN TESTED IN ACCORDANCE WITH SECTION 13.4 OF ASTM, A-974.

(C) **MANUFACTURING**
TWISTED WIRE MESH REVET MATTRASSES SHALL BE MANUFACTURED IN CONFORMANCE WITH ASTM A-975, WHILE WELDED WIRE MESH REVET MATTRASSES SHALL BE MANUFACTURED IN CONFORMANCE WITH ASTM A-974.

(4) **PVC COATING**
SEE CITY OF AUSTIN STANDARD SPECIFICATIONS ITEM NO 5945 GABIONS AND REVET MATTRASSES.

(5) **STONE**

(A) **GABION BASKET STONES**
STONE FILL SHALL BE DURABLE AND OF SUITABLE QUALITY TO ENSURE PERMANENCE IN THE STRUCTURE. THE STONE USED TO FILL THE GABION BASKETS SHALL BE A CLEAN, SOUND, AND DURABLE ROCK MEETING THE FOLLOWING REQUIREMENTS. IT SHALL HAVE A WEAR LOSS LESS THAN 30% WHEN THE STONE IS TESTED WITH THE LOS ANGELES ABRASION MACHINE IN ACCORDANCE WITH ASTM TEST METHOD C535 (TxDOT TEST METHOD TEX-410A). THE LOSS OF MATERIAL EXPERIENCED DURING FIVE CYCLES OF MAGNESIUM SULFATE EXPOSURE CONDUCTED IN ACCORDANCE WITH TxDOT TEST METHOD TEX-411A FOR ROCK RIP RAP SHALL NOT EXCEED 18%. THE STONE SHALL BE WELL GRADED TO PRODUCE A DENSE FILL, ANGULAR IN TEXTURE, WHILE MEETING THE FOLLOWING GRADATION REQUIREMENTS:

SIEVE SIZE	PERCENT BY WEIGHT (MASS)
US (SI)	% PASSING EACH INDIVIDUAL SIEVE
8 INCH (200 mm)	100
4 INCH (100 mm)	0-5
3 INCH (75 mm)	0

THE MINIMUM UNIT WEIGHT (UNIT MASS) OF A ROCKFILLED GABION SHALL BE 120 pcf (192 MEGAGRAMS (mg) PER CUBIC METER). VERIFICATION OF UNIT WEIGHT (MASS) SHALL BE PERFORMED WHEN ORDERED BY THE ENGINEER, BY CONSTRUCTING A TEST GABION WITH MATERIALS SUPPLIED FOR CONSTRUCTION WITH THE SAME EFFORT AND METHOD INTENDED FOR PRODUCTION GABIONS.

(6) **CONNECTIONS**
SEE CITY OF AUSTIN STANDARD SPECIFICATIONS ITEM NO 5945 GABIONS AND REVET MATTRASSES.
(7) **FASTENER SYSTEM**
SEE CITY OF AUSTIN STANDARD SPECIFICATIONS ITEM NO 5945 GABIONS AND REVET MATTRASSES.
(8) **PANEL TO PANEL JOINT STRENGTH**
SEE CITY OF AUSTIN STANDARD SPECIFICATIONS ITEM NO 5945 GABIONS AND REVET MATTRASSES.

NOTE: CONCRETE WALL OF THE WATER QUALITY POND SHALL BE CONSTRUCTED WITH WATER TIGHT JOINTS. SEE STRUCTURAL PLANS FOR REINFORCING, JOINTS, AND OTHERS DETAILS.

NOTE: WHERE A GEOMEMBRANE LINER IS USED IT SHALL HAVE A MINIMUM THICKNESS OF THIRTY (30) MILS. IT SHALL ALSO HAVE A 3"-4" FUSION WELD AT ALL SEAMS WITHIN THE LINER. ALL WELDS ARE TO BE AIR TESTED FOR ONE MINUTE. IF TEST FAILS REWELD SEAM AND TEST AGAIN.

FILTRATION BED SPECIFICATIONS

- SAND** - MINIMUM 18 INCHES OF 0.02-0.04 INCH DIAMETER SAND WHICH CORRESPONDS TO ASTM C-33 CONCRETE SAND (SMALLER SIZE SAND IS NOT ACCEPTABLE)
- GRAVEL** - 0.5 INCH MIN. TO 1.5 INCH DIAMETER WASHED ROUNDED RIVER GRAVEL WITH A MIN. 3 INCH COVER OVER TOP OF UNDERDRAIN LATERAL PIPING
- GEOTEXTILE FABRIC** - SAND & GRAVEL TO BE SEPARATED BY A LAYER OF GEOTEXTILE FABRIC THE FOLLOWING SPECIFICATIONS:

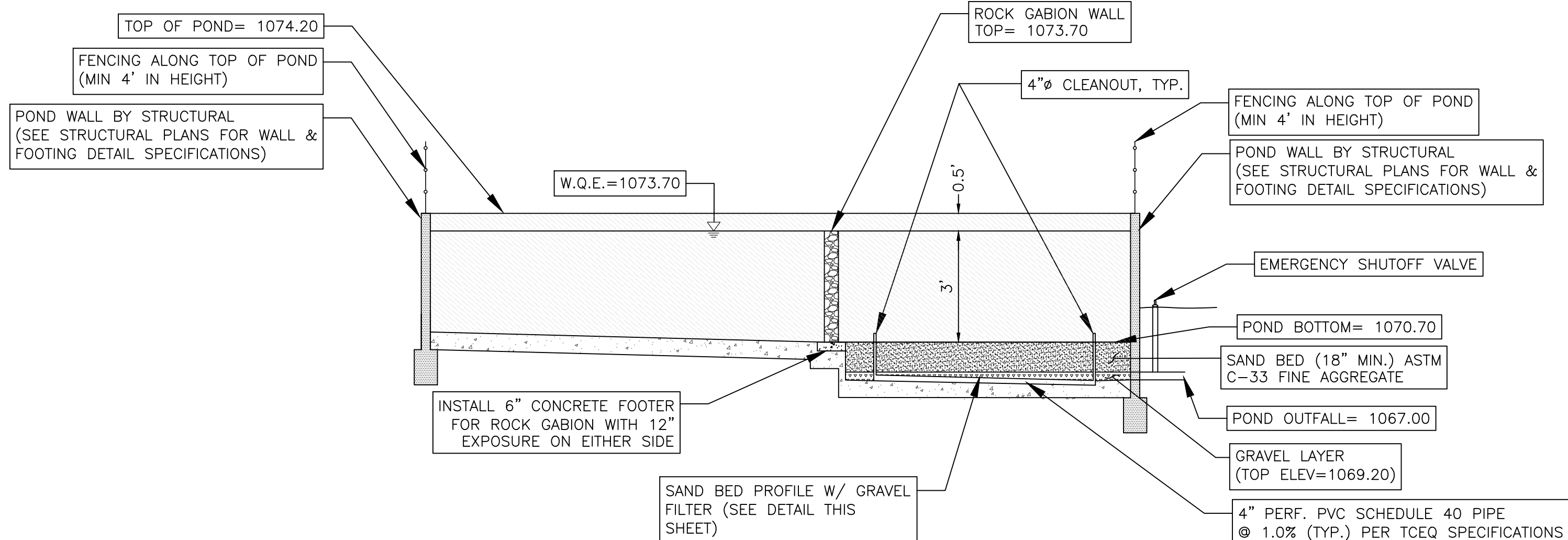

WATER QUALITY POND SECTION A-A

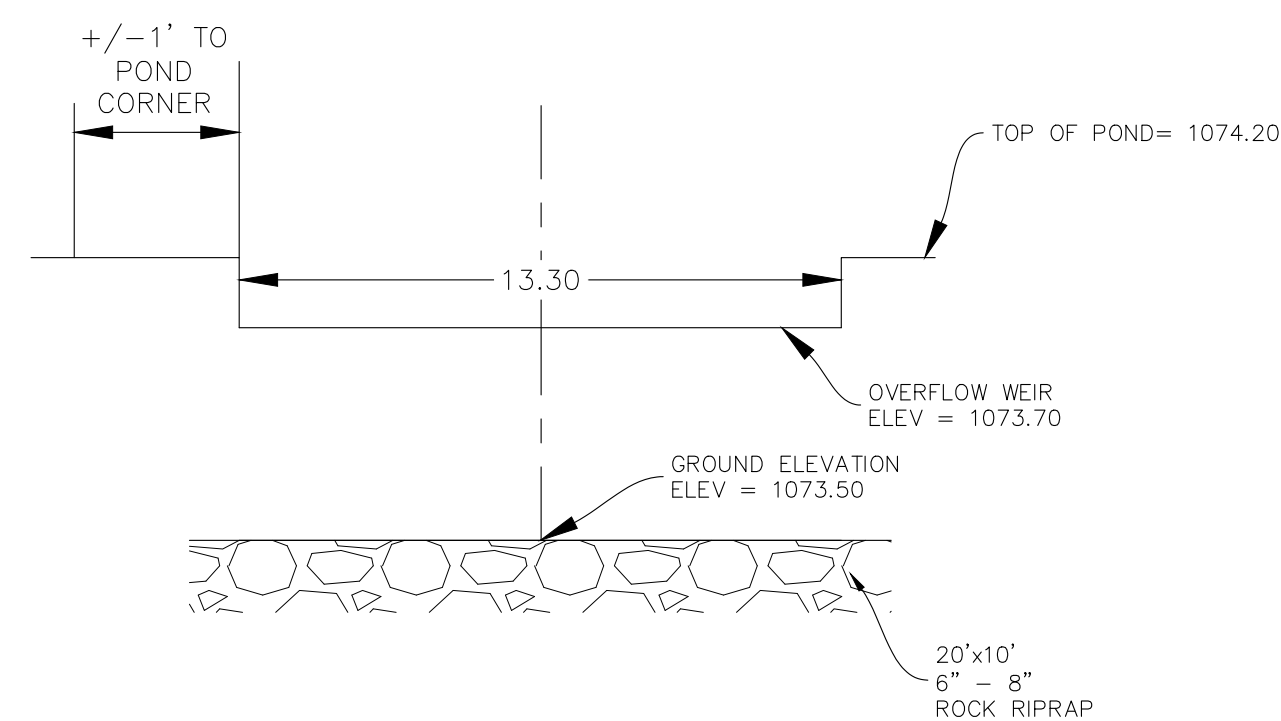

WEIR EQUATION:

$Q = Cw \times L \times Hw^{3/2}$

Cw = 3.09
Hw = 0.5 ft

Inlet OVERFLOW WEIR	Q25 Calculated	Hw	Required L	Provided L	Allowable Q
	14.50	0.50	13.29	13.30	14.52

DETAIL "A" - OVERFLOW WEIR

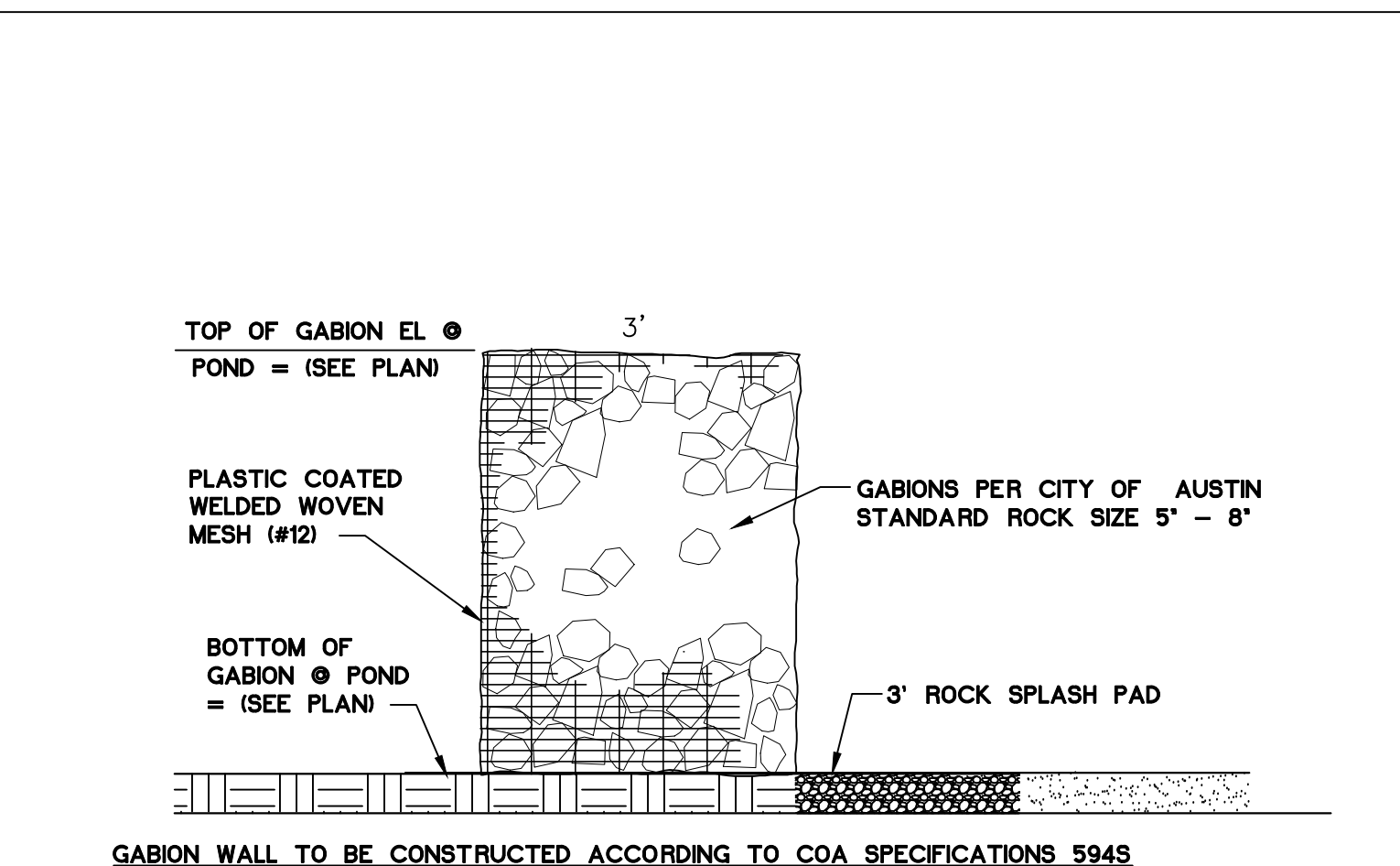

GABION BASKET WALL DETAIL

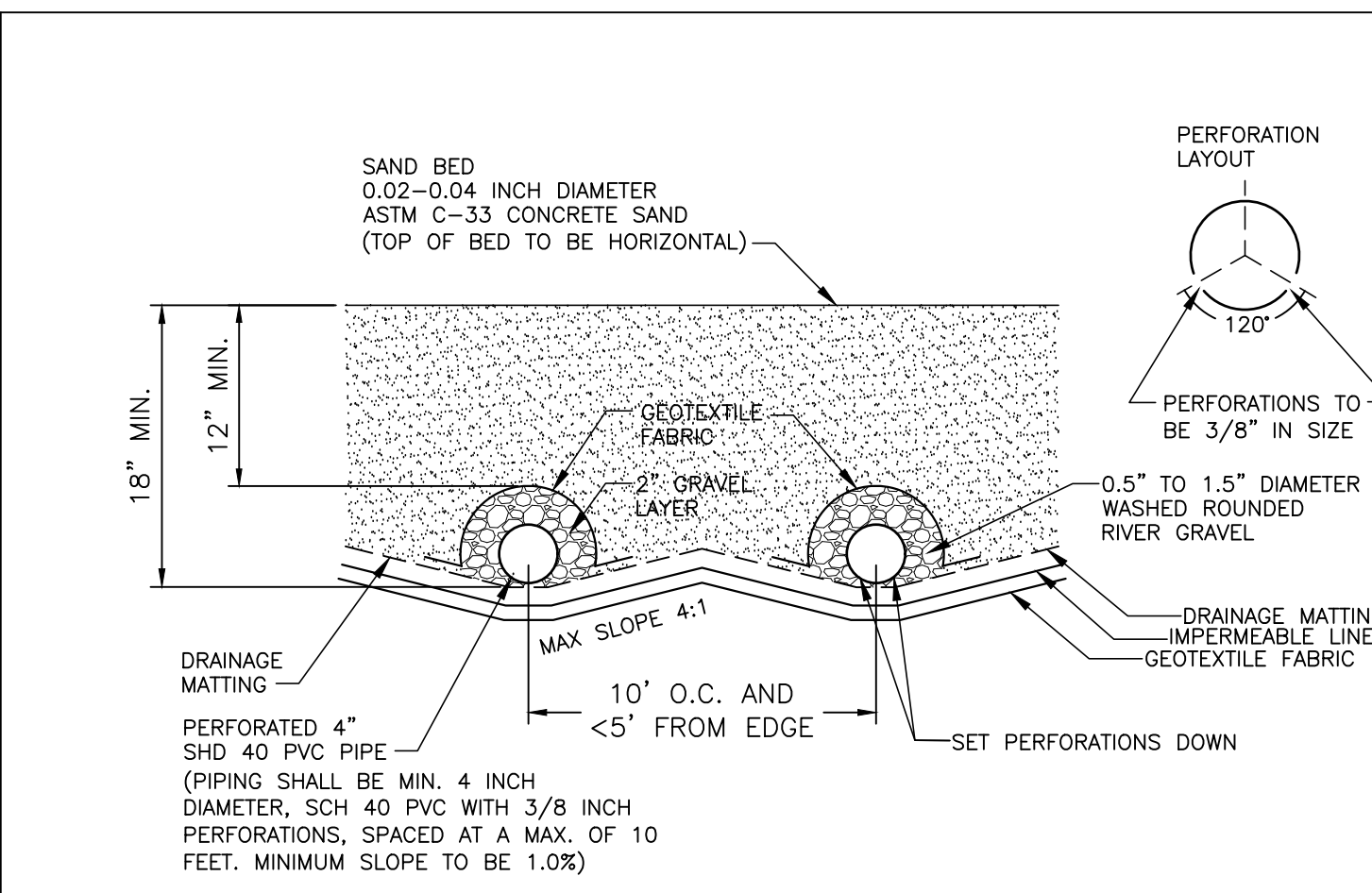

SAND BED PROFILE (WITH GRAVEL FILTER)

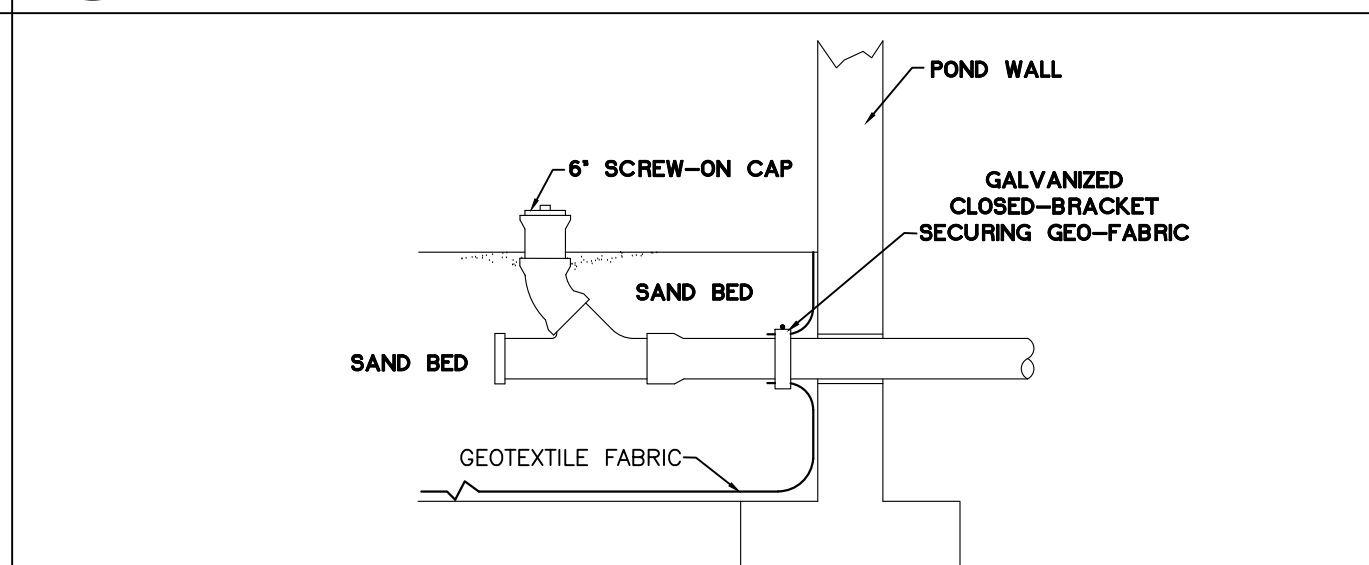

FABRIC ATTACHMENT TO OUTLET PIPE DETAIL

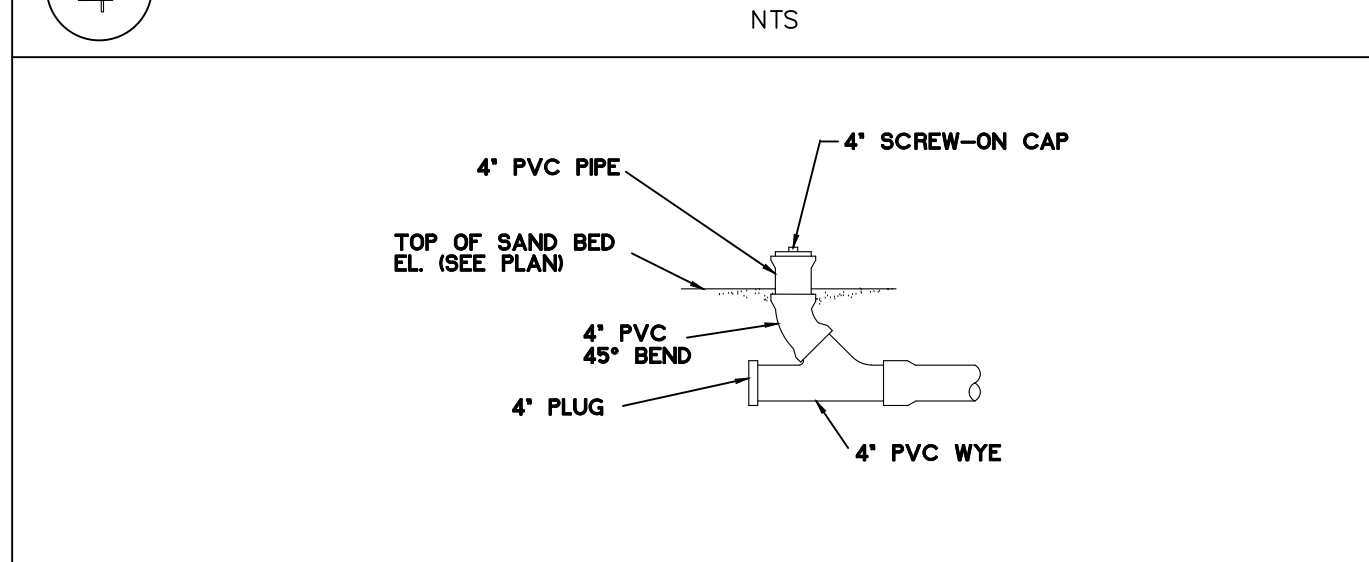

FILTRATION POND DRAIN PIPE CLEANOUT

GENERAL NOTES:

- CONTRACTOR SHALL FURNISH AND INSTALL ALL MATERIALS AND APPURTENANCES AS CALLED OUT ON PLANS.
- ALL GRAVITY LINES ARE TO BE INSTALLED FROM DOWNSTREAM TO UPSTREAM.
- ALL POND BOTTOMS, SIDE SLOPES, AND EARTHEN EMBANKMENTS SHALL BE COMPACTED TO NINETY-FIVE (95) PERCENT MAXIMUM DENSITY, IN ACCORDANCE WITH CITY OF AUSTIN STANDARD SPECIFICATIONS.
- RETAINING WALLS OVER FOUR FEET IN HEIGHT, MEASURED FROM THE BOTTOM OF THE FOOTING TO THE TOP OF THE WALL, SHALL BE ENGINEERED AND WILL REQUIRE A SEPARATE PERMIT (2009 INTERNATIONAL BUILDING CODE 105.2).

WARNING:
THE ENGINEER ASSUMES NO RESPONSIBILITY FOR THE ACCURACY OF THE LOCATION OF UNDERGROUND UTILITIES. THE CONTRACTOR SHALL BE RESPONSIBLE FOR AVOIDING ALL EXISTING UTILITIES BY CALLING TEXAS ONE CALL SYSTEM @ 811 FOR LOCATION OF ALL UTILITIES, AT LEAST 72 HOURS PRIOR TO BEGINNING CONSTRUCTION.

CAUTION:
CONTRACTOR TO VERIFY ALL EXISTING UTILITY LOCATIONS VERTICALLY AND HORIZONTALLY PRIOR TO START OF CONSTRUCTION.

SEDIMENTATION BASIN MAINTENANCE:

- SILT SHOULD BE REMOVED WHEN THE ACCUMULATION EXCEEDS SIX (6) INCHES IN SEDIMENT BASINS WITHOUT SEDIMENT TRAPS.
- ACCUMULATED PAPER, TRASH AND DEBRIS SHOULD BE REMOVED EVERY SIX (6) MONTHS OR AS NECESSARY.
- VEGETATION WITHIN THE BASIN SHOULD NOT BE ALLOWED TO EXCEED EIGHTEEN (18) INCHES IN HEIGHT AT ANY TIME, EXCEPT FOR THOSE PROVIDED IN THE DESIGN.
- THE BASIN SHOULD BE INSPECTED TWICE PER YEAR, AT LEAST ONCE AFTER A RAIN EVENT, AND REPAIRS SHOULD BE MADE IF NECESSARY.

FILTRATION BASIN MAINTENANCE:

- ACCUMULATED PAPER, TRASH AND DEBRIS SHOULD BE REMOVED EVERY SIX (6) MONTHS OR AS NECESSARY.
- CORRECTIVE MAINTENANCE IS REQUIRED ANY TIME DRAW-DOWN DOES NOT OCCUR WITHIN 48 HOURS.
- THE BASIN SHOULD BE INSPECTED TWICE PER YEAR, AT LEAST ONCE AFTER A RAIN EVENT, AND REPAIRS SHOULD BE MADE IF NECESSARY.

TABLE 1-9 DRAINAGE MATTING SPECIFICATIONS

PROPERTY	TEST METHOD	UNIT	SPECIFICATION
MATERIAL	NONWOVEN GEOTEXTILE FABRIC		
UNIT WEIGHT		OZ/SQ.YD.	20
FLOW RATE (FABRIC)		GPM/FT ²	180 (MIN.)
PERMEABILITY	ASTM D-2434	CM/SEC	12.4x10 ⁻²
GRAB STRENGTH (FABRIC)	ASTM D-1682	LB.	DRY LG. 90 DRY WD:70 WET LG. 95 WED WD:70
PUNCTURE STRENGTH (FABRIC)	ASTM COE CW-02215	LB.	42 (MIN.)
MULLEN BURST STRENGTH	ASTM D-1117	PSI	140 (MIN.)
EQUIV. OPENING SIZE	US STANDARD SIEVE	NO.	100 (70-120)
FLOW RATE (DRAINAGE CORE)	DREXEL UNIV. TEST METHOD	GPM/FT. WIDTH	14

SOURCE: CITY OF AUSTIN

GEOTEXTILE FABRIC SPECIFICATIONS

PROPERTY	TEST METHOD	UNIT	SPECIFICATION
MATERIAL	NONWOVEN GEOTEXTILE FABRIC		
UNIT WEIGHT		OZ/SQ.YD.	8
FILTRATION RATE		IN/SEC	0.08 (MIN.)
PUNCTURE STRENGTH	ASTM D-751 (MODIFIED)	LB.	125 (MIN.)
MULLEN BURST STRENGTH	ASTM D-751	PSI	400 (MIN.)
TENSILE STRENGTH	ASTM D-1682	LB.	200 (MIN.)
EQUIV. OPENING SIZE	US STANDARD SIEVE	NO.	80 (MIN.)

SOURCE: RG-348 TABLE 3-7 GEOTEXTILE FABRIC SPECIFICATIONS (COA, 2004)



MARSHALL AND BULVERDE, LLC
7410 BLANCO RD.
SAN ANTONIO, TEXAS 78216

HALFTIME 1
3125 SUMMIT CHURCH ROAD, SAN ANTONIO, TX 78259
WATER QUALITY POND DETAILS

REV	DATE	DESCRIPTION

DESIGNED BY:
DRAFTED BY:
CHECKED BY:

Date: Aug 02, 2011, 10:50 AM, User: J. Tyler
 Path: \\server\projects\2011\CG304\CG304.dwg, Plot: CG304 - WATER QUALITY POND.dwg

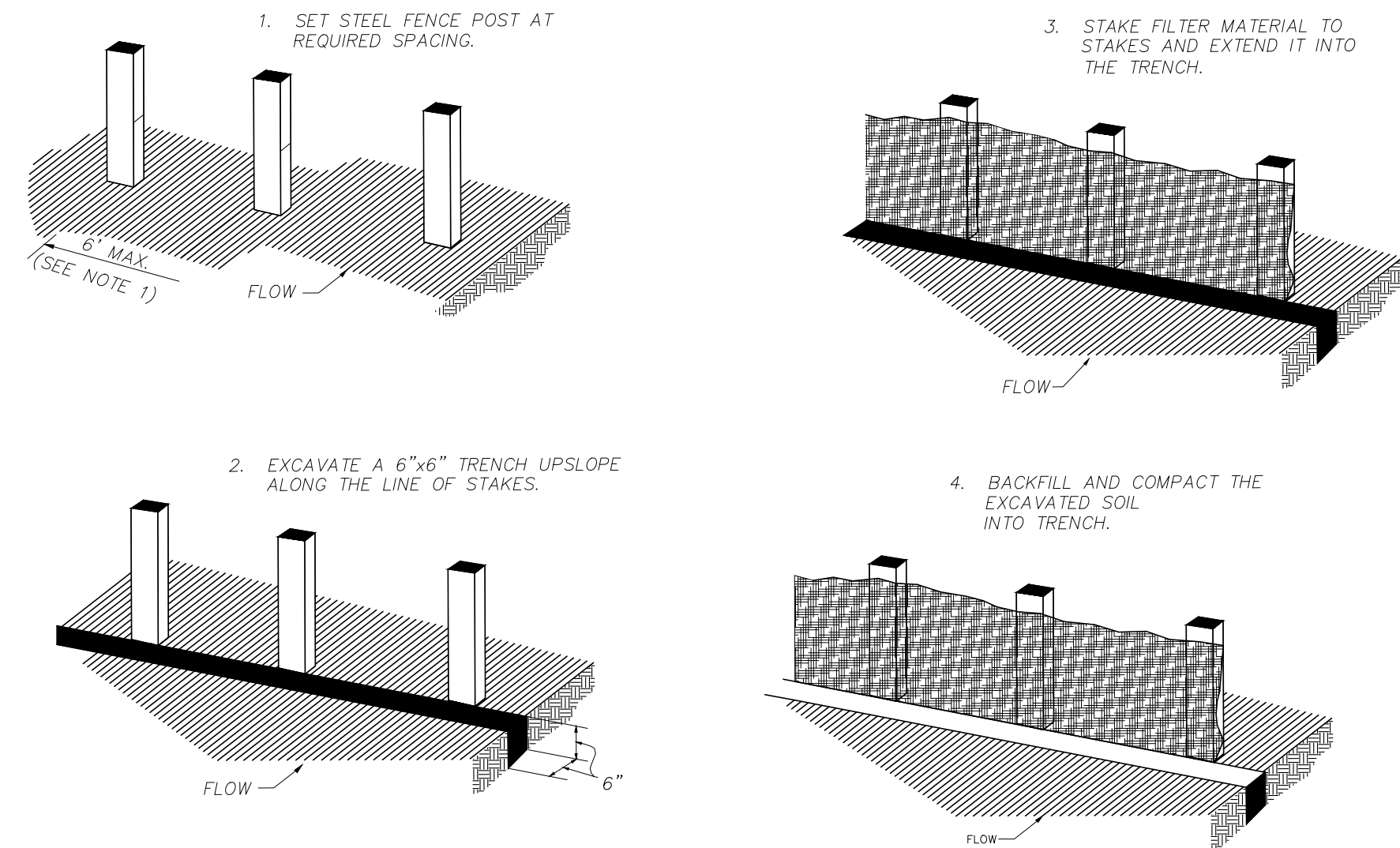

GENERAL NOTES:
 1. STEEL POSTS TO BE SET AT 3-FOOT MAXIMUM SPACING WITH MINIMUM EMBEDMENT OF 1-FOOT. IF FACTORY-PREASSEMBLED FENCE WITH SUPPORT NETTING IS USED, SPACING OF POST MAY BE INCREASED TO 8 FEET MAXIMUM.
 2. WHEN TWO SECTIONS OF FILTER CLOTH JOIN EACH OTHER THEY SHOULD BE OVERLAPPED 3 FEET AND SECURELY FASTENED WHEN ENDS OF FABRIC MEET.

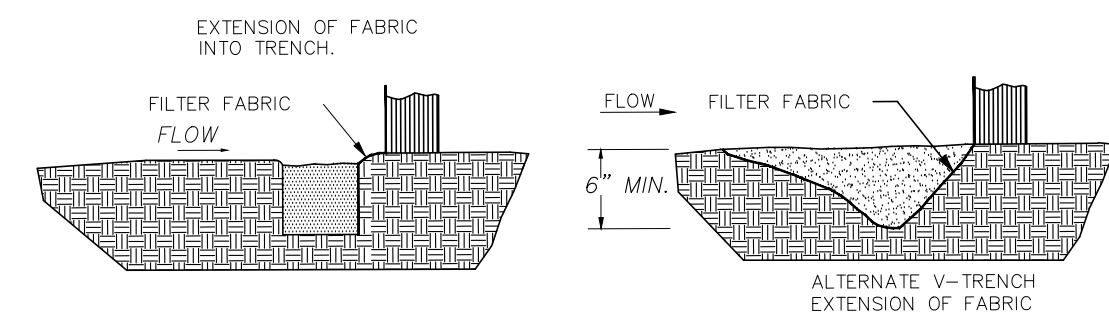

SILT FENCE

N.T.S.

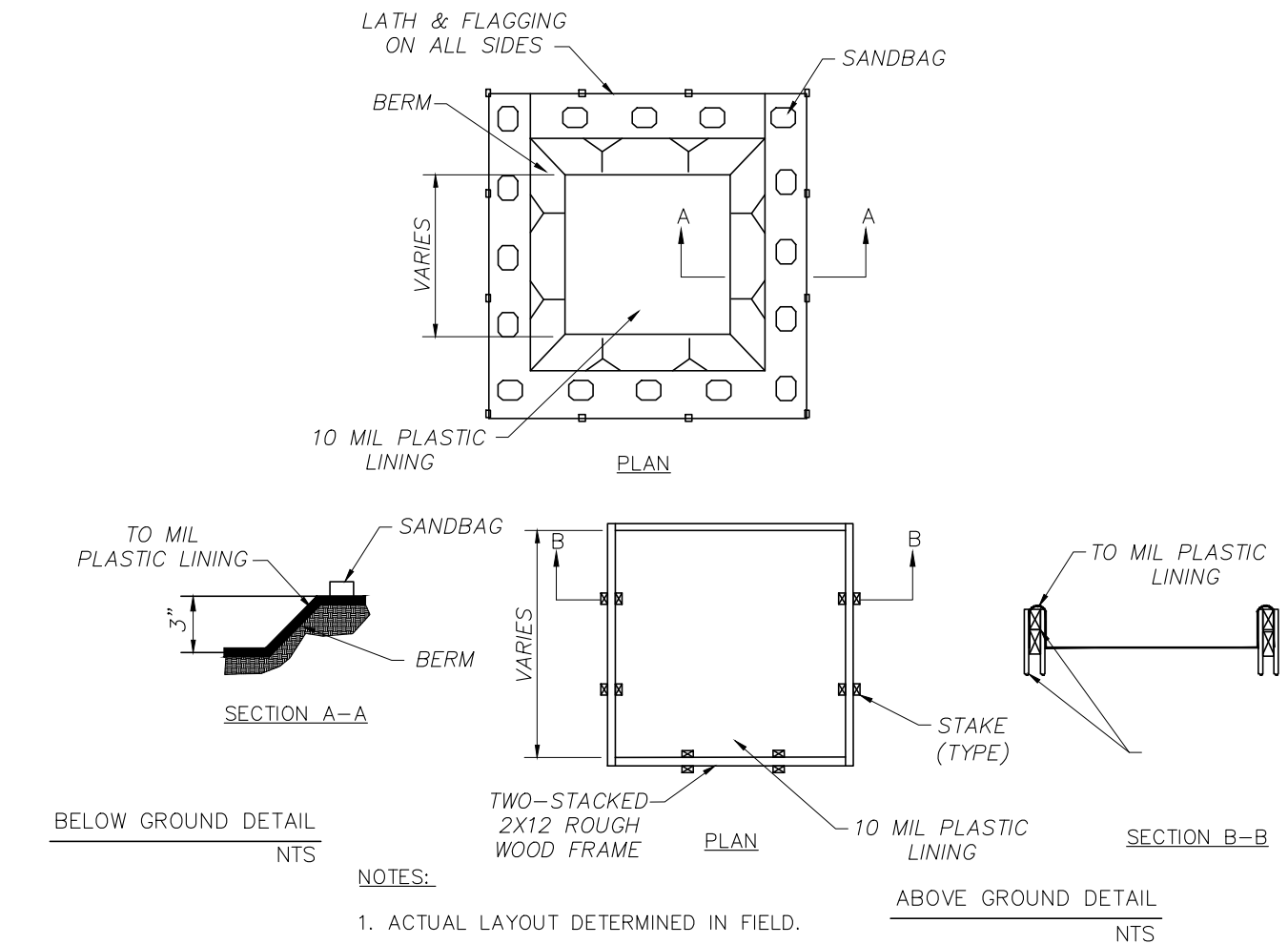

NOTES:
 1. ACTUAL LAYOUT DETERMINED IN FIELD.

CONCRETE WASHOUT AREA

N.T.S.

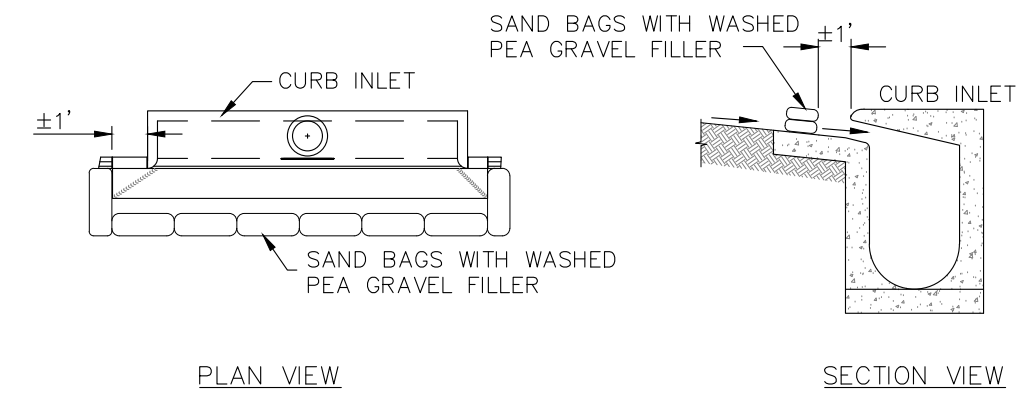

- NOTES:**
- SAND BAGS SHOULD BE PLACED TIGHTLY AGAINST EACH OTHER TO PREVENT RUNOFF FROM FLOWING BETWEEN BAGS.
 - SAND BAGS SHOULD BE FILLED WITH WASHED PEA GRAVEL AND STACKED TO FORM A CONTINUOUS BARRIER APPROXIMATELY 1 FOOT IN HEIGHT, APPROXIMATELY 1 FOOT FROM THE INLET OPENING.
 - INSPECTION SHOULD BE MADE WEEKLY AND AFTER EACH RAINFALL EVENT.
 - REMOVE SEDIMENT WHEN BUILDUP REACHES A DEPTH OF 3 INCHES.
 - STRUCTURES CAN BE REMOVED WHEN THE REMAINING DRAINAGE AREA CONSTRUCTION HAS CEASED AND THE AREA HAS BEEN PROPERLY STABILIZED.

CURB INLET PROTECTION OR APPROVED ALTERNATE METHOD

NOT TO SCALE

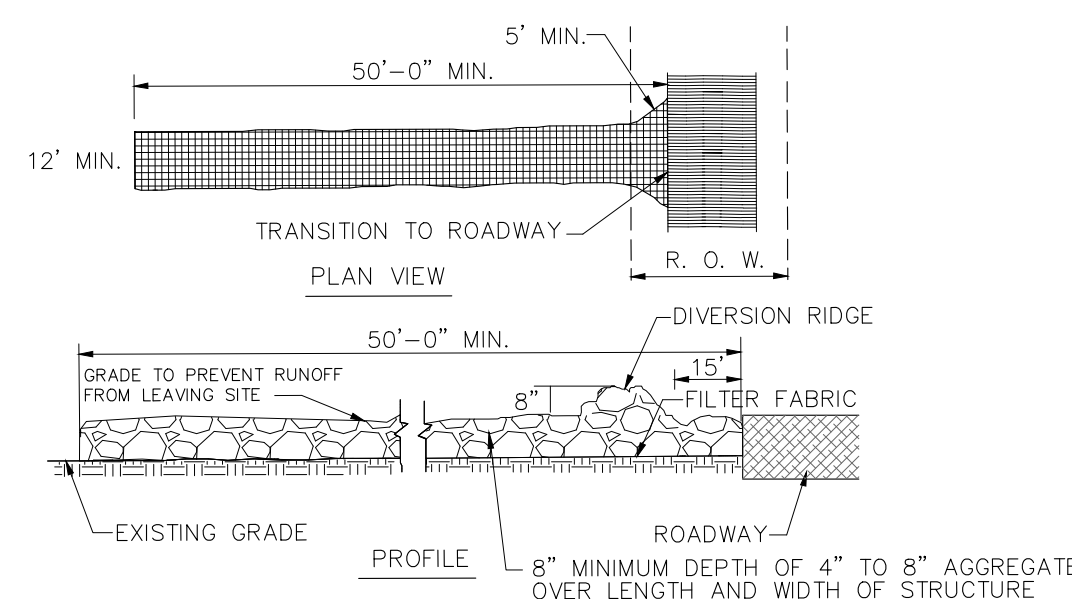

STABILIZED CONSTRUCTION EXIT

N.T.S.

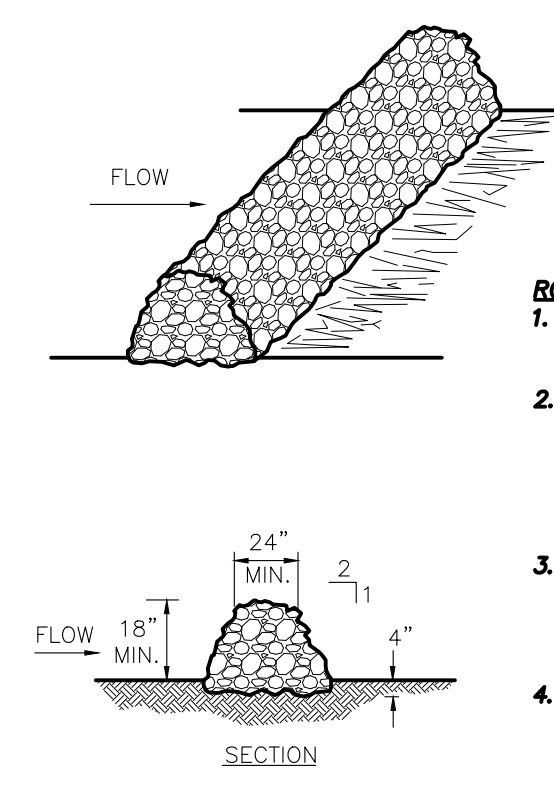

- ROCK BERM NOTES:**
- USE ONLY OPEN GRADED ROCK 100 TO 200 mm (4 TO 8") DIAMETER FOR STREAM FLOW CONDITIONS. USE OPEN GRADED ROCK 75 TO 125 mm (3 TO 5") DIAMETER FOR OTHER CONDITIONS.
 - THE ROCK BERM SHALL BE SECURED WITH A WOVEN WIRE SHEATHING HAVING MAXIMUM 25 mm (1") OPENING AND MINIMUM WIRE DIAMETER OF 12.9 mm (20 GAUGE). ROCK BERMS IN CHANNEL APPLICATIONS SHALL BE ANCHORED FIRMLY INTO THE SUBSTRATE A MINIMUM OF 150 mm (6") WITH T-POSTS OR WITH 15M OR 20M (#5 OR #6) REBAR, WITH MAXIMUM SPACING APART OF 1.2 m (48") ON CENTER.
 - THE ROCK BERM SHALL BE INSPECTED WEEKLY OR AFTER EACH RAIN, AND THE STONE AND/OR FABRIC CORE-WOVEN SHEATHING SHALL BE REPLACED WHEN THE STRUCTURE CEASES TO FUNCTION AS INTENDED, DUE TO SILT ACCUMULATION AMONG THE ROCKS, WASHOUT, CONSTRUCTION TRAFFIC DAMAGE, ETC.
 - WHEN SILT REACHES A DEPTH EQUAL TO ONE-THIRD THE HEIGHT OF THE BERM OR 150 mm (6"), WHICHEVER IS LESS, THE SILT SHALL BE REMOVED AND DISPOSED OF ON AN APPROVED SITE AND IN A MANNER THAT WILL NOT CREATE A SILTATION PROBLEM.
 - DAILY INSPECTION SHALL BE MADE ON SEVERE-SERVICE ROCK BERMS. SILT SHALL BE REMOVED WHEN ACCUMULATION REACHES 150 mm (6").
 - WHEN THE SITE IS COMPLETELY STABILIZED, THE BERM AND ACCUMULATED SILT SHALL BE REMOVED AND DISPOSED OF IN AN APPROVED MANNER.

ROCK FILTER DAM

N.T.S.

SEDIMENTATION AND EROSION CONTROLS

- DESIGN CRITERIA
 - FENCES ARE TO BE CONSTRUCTED ALONG LEVEL CONTOURS.
 - THE ENDS OF THE FENCE SHALL BE TURNED UPSTREAM TO PREVENT BYPASS OF STORMWATER.
 - STEEL POSTS WHICH SUPPORT THE SILT FENCE SHALL BE INSTALLED ON A SLIGHT ANGLE TOWARD THE ANTICIPATED RUNOFF SOURCE. POST MUST BE EMBEDDED A MINIMUM OF ONE FOOT.
 - THE TOE OF THE SILT FENCE SHALL BE TRENCHED IN WITH A SPADE OR MECHANICAL TRENCHER, SO THAT THE DOWNSLOPE FACE OF THE TRENCH IS FLAT AND PERPENDICULAR TO THE LINE OF FLOW. WHERE FENCE CANNOT BE TRENCHED IN (E.G. PAVEMENT), WEIGHT FABRIC FLAP WITH WASHED GRAVEL ON UPHILL SIDE TO PREVENT FLOW UNDER FENCE.
 - THE TRENCH MUST BE A MINIMUM OF 6 INCHES DEEP AND 6 INCHES WIDE TO ALLOW FOR THE SILT FENCE FABRIC TO BE LAID IN THE GROUND AND BACKFILLED WITH COMPACTED MATERIAL.
 - SILT FENCE SHOULD BE SECURELY FASTENED TO EACH STEEL SUPPORT POST OR TO WOVEN WIRE, WHICH IS IN TURN ATTACHED TO THE STEEL FENCE POST. THERE SHALL BE A 6" DOUBLE OVERLAP, SECURELY FASTENED WHERE ENDS OF FABRIC MEET.
 - INSPECTION SHALL BE MADE WEEKLY OR AFTER EACH RAINFALL. REPAIR OR REPLACEMENT SHALL BE MADE PROMPTLY AS NEEDED.
 - ACCUMULATED SILT SHALL BE REMOVED WHEN IT REACHES A DEPTH OF 6 INCHES. THE SILT SHALL BE DISPOSED OF IN AN APPROVED SITE AND IN SUCH A MANNER AS TO NOT CONTRIBUTE TO THE ADDITIONAL SILTATION.
- TEMPORARY DIVERSION DIKE
 - MAXIMUM DEPTH OF FLOW AT THE DIKE SHALL BE 1 FOOT.
 - SIDE SLOPES OF THE DIVERSION DIKE SHALL BE 3:1 OR FLATTER.
 - MINIMUM WIDTH OF THE EMBANKMENT AT THE TOP SHALL BE 2 FEET.
 - MINIMUM EMBANKMENT HEIGHT SHALL BE 18 INCHES AS MEASURED FROM THE TOE OF SLOPE ON THE UPGRADE SIDE OF THE BERM.
 - THE DIKES SHALL REMAIN IN PLACE UNTIL ALL DISTURBED AREAS WHICH ARE PROTECTED BY THE DIKE ARE PERMANENTLY STABILIZED UNLESS OTHER CONTROLS ARE PUT INTO PLACE TO PROTECT THE SITE.
 - COMPACTED EARTH DIKES REQUIRE STABILIZATION IMMEDIATELY UPON PLACEMENT SO AS NOT TO CONTRIBUTE TO THE PROBLEM THEY ARE ADDRESSING.
 - ALL DIVERSION DIKES SHALL HAVE POSITIVE DRAINAGE TO AN OUTLET.
 - DIKES MUST BE INSPECTED ON A REGULAR BASIS TO DETERMINE IF SILT IS BUILDING UP BEHIND THE DIKE, OR IF EROSION IS OCCURRING ON THE FACE OF THE DIKE. SILT SHALL BE REMOVED IN A TIMELY MANNER. IF EROSION IS OCCURRING ON THE FACE OF THE DIKE, THE SLOPES OF THE FACE SHALL BE STABILIZED.
- INTERCEPTOR SWALE
 - MAXIMUM DEPTH OF FLOW IN THE SWALE SHALL BE 1 FOOT.
 - THE MINIMUM BOTTOM WIDTH OF THE SWALE SHALL BE 3:1 OR FLATTER.
 - SIDE SLOPES OF THE SWALE SHALL BE 3:1 OR FLATTER.
 - MINIMUM DESIGN CHANNEL FREEBOARD SHALL BE 6 INCHES.
 - SWALES MUST MAINTAIN POSITIVE GRADE TO AN ACCEPTABLE OUTLET.
 - INTERCEPTOR SWALES MUST BE STABILIZED IMMEDIATELY UPON EXCAVATION SO AS NOT TO CONTRIBUTE TO THE EROSION PROBLEM THEY ARE ADDRESSING.
 - ALL TREES, BRUSH, STUMPS, OBSTRUCTIONS AND OTHER MATERIAL SHALL BE REMOVED AND DISPOSED OF SO AS NOT TO INTERFERE WITH THE PROPER FUNCTIONING OF THE SWALE.
 - ALL EARTH REMOVED AND NOT NEEDED IN CONSTRUCTION SHALL BE DISPOSED OF IN AN APPROVED SPOILS SITE.
 - INSPECTION MUST BE MADE AFTER EACH RAIN EVENT TO LOCATE AND REPAIR ANY DAMAGE TO THE CHANNEL OR TO CLEAR DEBRIS OR OTHER OBSTRUCTIONS SO AS NOT TO DIMINISH FLOW CAPACITY. DAMAGES WHICH RESULT FROM NORMAL CONSTRUCTION ACTIVITIES SHALL BE REPAIRED AT THE END OF EACH WORK DAY.
- HAY BALE DIKE
 - EACH HAY BALE SHALL BE PLACED INTO AN EXCAVATED TRENCH HAVING A DEPTH OF 4 INCHES AND A WIDTH JUST WIDE ENOUGH TO ACCOMMODATE THE BALES THEMSELVES.
 - HAY BALES SHALL BE INSTALLED IN SUCH A WAY THAT THERE IS NO SPACE BETWEEN TO ALLOW FOR ANY KIND OF SEEPAGE.
 - INDIVIDUAL BALES SHALL BE HELD IN PLACE BY NO LESS THAN TWO WOOD OR STEEL STAKES DRIVEN A MINIMUM DISTANCE OF 6 INCHES INTO UNDISTURBED GROUND, WITH THE FIRST STAKE DRIVEN AT AN ANGLE TOWARD THE PREVIOUSLY INSTALLED BALE.
 - THE ENDS OF THE DIKE SHALL BE TURNED UPSTREAM TO PREVENT BYPASS OF STORMWATER.
 - INSPECTION SHALL BE WEEKLY OR AFTER EACH RAINFALL EVENT AND REPAIR OR REPLACEMENT SHALL BE MADE PROMPTLY AS NEEDED BY THE CONTRACTOR.
 - WHEN SILT REACHES A DEPTH OF 6 INCHES, IT SHALL BE REMOVED AND DISPOSED OF IN AN APPROVED SITE.
 - HAY BALES SHALL BE REPLACED IF THERE ARE SIGNS OF DEGRADATION SUCH AS STRAW LOCATED DOWNSTREAM FROM THE BALES, STRUCTURAL DEFICIENCIES DUE TO ROTTING STRAW IN THE BALE OR OTHER SIGNS OF DETERIORATION. SEDIMENT SHOULD BE REMOVED FROM BEHIND THE BALES WHEN IT REACHES A DEPTH OF APPROXIMATELY 6 INCHES. IF THE BALES BECOME CLOGGED, THEY SHOULD BE REPLACED IMMEDIATELY.
- SANDBAG BERM
 - MINIMUM HEIGHT SHALL BE 18 INCHES.
 - MINIMUM WIDTH OF THE BERM SHALL BE 18 INCHES AT THE TOP AND 48 INCHES MEASURED AT THE BOTTOM.
 - MAXIMUM SIDE SLOPES SHALL BE 2:1.
 - THE ENDS OF THE BERM SHALL BE TURNED UPGRADE OR SHALL BE INTO NATURAL GRADES TO PREVENT BYPASS OF STORMWATER.
 - SANDBAGS SHOULD BE STACKED IN AT LEAST THREE ROWS ABUTTING EACH OTHER, AND IN STAGGERED ARRANGEMENT.
 - INSPECTIONS SHOULD BE MADE ON A DAILY BASIS AND AFTER EACH RAIN EVENT. THE SANDBAGS SHALL BE RESHAPED OR REPLACED AS NEEDED DURING THE INSPECTION. SILT SHOULD BE REMOVED WHEN IT REACHES A DEPTH OF SIX (6) INCHES.
- STONE OUTLET SEDIMENT TRAP
 - MINIMUM WIDTH OF THE EMBANKMENT AT THE TOP SHALL BE 3 FEET PERPENDICULAR TO THE FLOW.
 - MINIMUM EMBANKMENT SLOPE SHALL BE 3:1.
 - MAXIMUM EMBANKMENT HEIGHT SHALL BE 2 FEET AS MEASURED FROM THE TOE OF SLOPE TO THE CREST OF THE STONE OUTLET. THE HEIGHT OF THE COMPACTED EARTH EMBANKMENT SHALL BE ONE FOOT HIGHER THAN THE CREST OF THE OUTLET.
 - SEDIMENT SHALL BE REMOVED AND THE AREA DIRECTLY BEHIND THE BERM SHALL BE REGRADED TO ITS ORIGINAL DIMENSIONS AT SUCH POINT WHEN THE CAPACITY OF IMPOUNDMENT HAS BEEN REDUCED TO ONE-HALF OF ITS ORIGINAL STORAGE CAPACITY.
 - SANDBAGS SHOULD BE STACKED IN AT LEAST THREE ROWS ABUTTING EACH OTHER, AND IN STAGGERED ARRANGEMENT.
 - INSPECTIONS SHOULD BE MADE ON A DAILY BASIS AND AFTER EACH RAIN EVENT. THE SANDBAGS SHALL BE RESHAPED OR REPLACED AS NEEDED DURING THE INSPECTION. SILT SHOULD BE REMOVED WHEN IT REACHES A DEPTH OF SIX (6) INCHES.
- STONE OUTLET SEDIMENT TRAP
 - MINIMUM WIDTH OF THE EMBANKMENT AT THE TOP SHALL BE 3 FEET PERPENDICULAR TO THE FLOW.
 - MINIMUM EMBANKMENT SLOPE SHALL BE 3:1.
 - MAXIMUM EMBANKMENT HEIGHT SHALL BE 2 FEET AS MEASURED FROM THE TOE OF SLOPE TO THE CREST OF THE STONE OUTLET. THE HEIGHT OF THE COMPACTED EARTH EMBANKMENT SHALL BE ONE FOOT HIGHER THAN THE CREST OF THE OUTLET.
 - SEDIMENT SHALL BE REMOVED AND THE AREA DIRECTLY BEHIND THE BERM SHALL BE REGRADED TO ITS ORIGINAL DIMENSIONS AT SUCH POINT WHEN THE CAPACITY OF IMPOUNDMENT HAS BEEN REDUCED TO ONE-HALF OF ITS ORIGINAL STORAGE CAPACITY.
 - THE STONE OUTLET STRUCTURE SHOULD BE INSPECTED FREQUENTLY AND AFTER EACH MAJOR RAIN EVENT TO CHECK FOR CLOGGING OF THE VOID SPACES BETWEEN STONES. IF THE AGGREGATE APPEARS TO BE SILTED IN SUCH THAT EFFICIENCY IS DIMINISHED, THE STONE SHOULD BE REPLACED.
- SEDIMENT BASIN
 - MAXIMUM DRAINAGE AREA CONTRIBUTING TO THE BASIN SHALL BE 100 ACRES.
 - DEPOSITED SEDIMENT SHALL BE REMOVED WHEN THE STORAGE CAPACITY OF THE BASIN HAS BEEN DEPLETED BY ONE-HALF.
 - MINIMUM WIDTH OF THE EMBANKMENT AT THE TOP SHALL BE 6 FEET.
 - MINIMUM EMBANKMENT SLOPE SHALL BE 3:1.
 - SEDIMENT SHALL BE REMOVED AND THE BASIN SHALL BE REGRADED TO ITS ORIGINAL DIMENSIONS. THE REMOVED SEDIMENT MAJOR BE STOCKPILED OR REDISTRIBUTED IN AREAS WHICH ARE PROTECTED FROM EROSION.
 - THE BASIN OUTLET STRUCTURE AND EMERGENCY SPILLWAY (IF PRESENT) SHOULD BE CHECKED FREQUENTLY AND AFTER EACH MAJOR RAIN EVENT TO CHECK FOR DAMAGE.
- STABILIZED CONSTRUCTION EXIT
 - STONE SIZE - 3 TO 5 INCHES CRUSHED ROCK.
 - LENGTH - AS EFFECTIVE, BUT NOT LESS THAN 50 FEET, UNLESS DEPTH OF LOT IS LESS THAN 150 FEET FROM EDGE OF PAVEMENT WHERE LENGTH MUST ONLY BE 30 FEET.
 - THICKNESS - NOT LESS THAN 8 INCHES.
 - WIDTH - NOT LESS THAN FULL WIDTH OF ALL POINTS OF INGRESS OR EGRESS.
 - WASHING - WHEN NECESSARY, WHEELS SHALL BE CLEANED TO REMOVE SEDIMENT PRIOR TO ENTRANCE ONTO PUBLIC ROADWAY. WHEN WASHING IS REQUIRED, IT SHALL BE DONE ON AN AREA STABILIZED WITH CRUSHED STONE WHICH DRAINS INTO AN APPROVED TRAP OR SEDIMENT BASIN. ALL SEDIMENT SHALL BE PREVENTED FROM ENTERING ANY STORM DRAIN, DITCH OR WATERCOURSE USING APPROVED METHODS.
 - MAINTENANCE - THE ENTRANCE SHALL BE MAINTAINED IN CONDITION WHICH WILL PREVENT TRACKING OR FLOWING OF SEDIMENT ONTO PUBLIC ROADWAYS. THIS MAY REQUIRE PERIODIC TOP DRESSING WITH ADDITIONAL STONE AS CONDITIONS DEMAND, AND REPAIR AND/OR CLEANOUT OF ANY MEASURES USED TO TRAP SEDIMENT. ALL SEDIMENT SPILLED, DROPPED, WASHED OR TRACKED ONTO PUBLIC ROADWAY, MUST BE REMOVED IMMEDIATELY.
 - DRAINAGE - ENTRANCE MUST BE PROPERLY GRADED OR INCORPORATE A DRAINAGE SWALE TO PREVENT RUNOFF FROM LEAVING THE CONSTRUCTION SITE.
- ADDITIONAL NOTES:
 - UPON COMPLETION OF CONSTRUCTION ALL DISTURBED AREAS SHALL BE REVEGETATED TO 85% OF EXISTING CONDITIONS IN ACCORDANCE WITH THE SWPPP AND TPDES REQUIREMENTS.
 - THIS PROJECT WILL NOT USE ANY OFF-SITE MATERIAL, WASTE/BORROW/FILL, OR EQUIPMENT STORAGE AREAS.
 - THIS SITE IS NOT LOCATED ADJACENT TO ANY SURFACE WATERS.
 - THIS SITE WILL NOT HAVE ANY LOCATIONS WHERE STORM WATER DISCHARGES DIRECTLY TO A SURFACE WATER BODY.

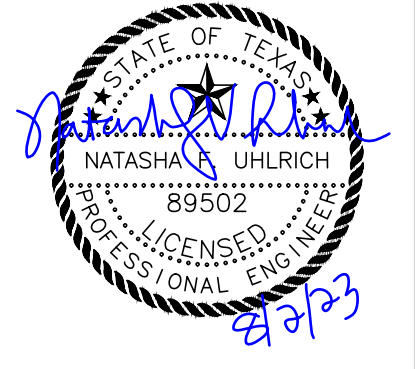

MARSHALL AND BULVERDE, LLC
 7410 BLANCO RD.
 SAN ANTONIO, TEXAS 78216

HALFTIME 1
 3125 SUMMIT CHURCH ROAD, SAN ANTONIO, TX 78259
STORM WATER POLLUTION PREVENTION
PLAN DETAILS

REV	DATE	DESCRIPTION	BY

DESIGNED BY: JQS
 DRAFTED BY: JQS
 CHECKED BY: TS

SHEET
C201
 5 OF 21

Drawn: April 02, 2024, 2:50 PM, User: JQS, Title: Storm Water Pollution Prevention Plan, C-Storm Washout, Sheet: C201 - 5/8/24, User: JQS

Attachment G

Inspection, Maintenance, Repair and Retrofit Plan

Inspection, Maintenance, Repair and Retrofit Plan

Project Name Halftime 1

Address 7410 Blanco Road, Suite 225

City, State, Zip Code San Antonio, TX 78216

SEDIMENTATION BASINS

Weekly: While construction of lots is ongoing within the basin drainage area, the basin shall be checked for accumulation of trash and debris. Trash and debris shall be removed if excessive.

The level of accumulated silt shall also be checked weekly while construction of lots is ongoing within the basin drainage area. If depth of silt exceeds 6-inches, it shall be removed and disposed of "properly".

Monthly: The vegetative growth in the basin shall be checked. The growth shall not exceed 18 inches in height.

Quarterly: The level of accumulated silt shall be checked. If depth of silt exceeds 6 inches, it shall be removed and disposed of "properly".

The basin shall be checked for accumulation of debris and trash. The debris and trash shall be removed if excessive. All debris and trash shall be removed at least every six months.

Annually: The basin shall be inspected for structural integrity and repaired if necessary.

After Rainfall: The basin shall be checked after each rainfall occurrence to ensure that it drains within 24-hours after the storm is over. If it does not drain within this time, corrective maintenance will be accomplished.

FILTRATION BASINS

Weekly: While construction of lots is ongoing within the basin drainage area, the basin shall be checked for accumulation of trash and debris. Trash and debris shall be removed if excessive.

The level of accumulated silt shall also be checked weekly while construction of lots is ongoing within the basin drainage area. If depth of silt exceeds ½ inch, it shall be removed and disposed of "properly".

Monthly: The vegetative growth shall be checked. Vegetation in the basin shall not exceed 18 inches in height.

Quarterly: The level of accumulated silt shall be checked. If depth of silt/pollutants exceeds ½ inch, it shall be removed and disposed of "properly".

The accumulation of pollutants/oils shall be checked. If the pollutants have significantly reduced the designed capacity of the sand filter, the pollutants shall be removed.

The basin shall be checked for accumulation of debris and trash. The debris and trash shall be removed if excessive. All debris and trash shall be removed at least every six months.

Annually: The basin shall be inspected for structural integrity and repaired if necessary.

After Rainfall: The basin shall be checked after each rainfall occurrence to ensure that it drains within 36 hours after the sedimentation basin has been emptied. If it does not drain within this time, corrective maintenance will be accomplished.

Following any required maintenance, the surface of the filtration basin shall be raked and leveled to restore the system to its designed condition.

*"Proper" disposal of accumulated silt shall be accomplished following Texas Water Commission and City of San Antonio guidelines and specifications.

VEGETATIVE FILTER STRIPS

Once a vegetated area is well established, little additional maintenance is generally necessary. The key to establishing a viable vegetated feature is the care and maintenance it receives in the first few months after it is planted. Once established, all vegetated BMPs require some basic maintenance to insure the health of the plants including:



- *Pest Management.* An Integrated Pest Management (IPM) Plan should be developed for vegetated areas. This plan should specify how problem insects and weeds will be controlled with minimal or no use of insecticides and herbicides.
- *Seasonal Mowing and Lawn Care.* If the filter strip is made up of turf grass, it should be mowed as needed to limit vegetation height to 18 inches, using a mulching mower (or removal of clippings). If native grasses are used, the filter may require less frequent mowing, but a minimum of twice annually. Grass clippings and brush debris should not be deposited on vegetated filter strip areas. Regular mowing should also include weed control practices, however herbicide use should be kept to a minimum (Urbonas et al., 1992). Healthy grass can be maintained without using fertilizers because runoff usually contains sufficient nutrients. Irrigation of the site can help assure a dense and healthy vegetative cover.
- *Inspection.* Inspect filter strips at least twice annually for erosion or damage to vegetation; however, additional inspection after periods of heavy runoff is most desirable. The strip should be checked for uniformity of grass cover, debris and litter, and areas of sediment accumulation. More frequent inspections of the grass cover during the first few years after establishment will help to determine if any problems are developing, and to plan for long-term restorative maintenance needs. Bare spots and areas of erosion

identified during semi-annual inspections must be replanted and restored to meet specifications. Construction of a level spreader device may be necessary to reestablish shallow overland flow.

- *Debris and Litter Removal.* Trash tends to accumulate in vegetated areas, particularly along highways. Any filter strip structures (i.e. level spreaders) should be kept free of obstructions to reduce floatables being flushed downstream, and for aesthetic reasons. The need for this practice is determined through periodic inspection but should be performed no less than 4 times per year.
- *Sediment Removal.* Sediment removal is not normally required in filter strips, since the vegetation normally grows through it and binds it to the soil. However, sediment may accumulate along the upstream boundary of the strip preventing uniform overland flow. Excess sediment should be removed by hand or with flat-bottomed shovels.
- *Grass Reseeding and Mulching.* A healthy dense grass should be maintained on the filter strip. If areas are eroded, they should be filled, compacted, and reseeded so that the final grade is level. Grass damaged during the sediment removal process should be promptly replaced using the same seed mix used during filter strip establishment. If possible, flow should be diverted from the damaged areas until the grass is firmly established. Bare spots and areas of erosion identified during semi-annual inspections must be replanted and restored to meet specifications. Corrective maintenance, such as weeding, or replanting should be done more frequently in the first two to three years after installation to ensure stabilization. Dense vegetation may require irrigation immediately after planting, and during particularly dry periods, particularly as the vegetation is initially established.

*"Proper" disposal of accumulated silt shall be accomplished following Texas Commission on Environmental Quality and City of San Antonio guidelines and specifications.

An amended copy of this document will be provided to the Texas Water Commission within thirty (30) days of any changes in the following information.

Responsible Party for Maintenance	<u>Marshall Bulverde LLC</u>
Address	<u>7410 Blanco Road, Suite 225</u>
City, State Zip	<u>San Antonio, TX 78249</u>
Telephone Number	<u>210-316-8880</u>
Signature of Responsible Party	<u></u>
Plan prepared by UP Engineering in conformance with TCEQ regulations	<u></u>

Attachment H

Pilot-Scale Field Testing Plan

Pilot-Scale Field Testing Plan

Not Applicable

Attachment I

Measures for Minimizing Surface Stream Contamination

Measures for Minimizing Surface Stream Contamination

Vegetative filter strips and an on-site sedimentation/filtration basin will be used as permanent controls to treat storm water runoff before it enters the stream. Bypass areas not captured and treated by the basins will continue to drain naturally into Long Creek. The velocities of any proposed drainage swales will be designed for 6 fps or less to prevent erosion and allow natural grass lined channels to be used if necessary.

Agent Authorization Form (TCEQ-0599)

SIGNATURE PAGE:

[Signature]
Applicant's Signature

4-4-2023
Date

THE STATE OF Texas §

County of Bexar §

BEFORE ME, the undersigned authority, on this day personally appeared KARIM ALI known to me to be the person whose name is subscribed to the foregoing instrument, and acknowledged to me that (s)he executed same for the purpose and consideration therein expressed.

GIVEN under my hand and seal of office on this 4th day of April 2023.

[Signature]
NOTARY PUBLIC

Trayce L. Cerwick
Typed or Printed Name of Notary



MY COMMISSION EXPIRES: 12/9/2025

Application Fee Form (TCEQ-0574)

Application Fee Form

Texas Commission on Environmental Quality

Name of Proposed Regulated Entity: Halftime 1
 Regulated Entity Location: Corner of Bulverde Rd and Marshall Rd
 Name of Customer: Bulverde Marshall LLC
 Contact Person: Karim Ali Phone: _____
 Customer Reference Number (if issued): CN _____
 Regulated Entity Reference Number (if issued): RN _____

Austin Regional Office (3373)

Hays Travis Williamson

San Antonio Regional Office (3362)

Bexar Medina Uvalde
 Comal Kinney

Application fees must be paid by check, certified check, or money order, payable to the **Texas Commission on Environmental Quality**. Your canceled check will serve as your receipt. **This form must be submitted with your fee payment.** This payment is being submitted to:

Austin Regional Office San Antonio Regional Office
 Mailed to: TCEQ - Cashier Overnight Delivery to: TCEQ - Cashier
 Revenues Section 12100 Park 35 Circle
 Mail Code 214 Building A, 3rd Floor
 P.O. Box 13088 Austin, TX 78753
 Austin, TX 78711-3088 (512)239-0357

Site Location (Check All That Apply):

Recharge Zone Contributing Zone Transition Zone

Type of Plan	Size	Fee Due
Water Pollution Abatement Plan, Contributing Zone Plan: One Single Family Residential Dwelling	Acres	\$
Water Pollution Abatement Plan, Contributing Zone Plan: Multiple Single Family Residential and Parks	Acres	\$
Water Pollution Abatement Plan, Contributing Zone Plan: Non-residential	12.30 Acres	\$ \$6,500
Sewage Collection System	845 L.F.	\$ \$650
Lift Stations without sewer lines	Acres	\$
Underground or Aboveground Storage Tank Facility	Tanks	\$
Piping System(s)(only)	Each	\$
Exception	Each	\$
Extension of Time	Each	\$

Signature: 

Date: 07/31/2023

Application Fee Schedule

Texas Commission on Environmental Quality

Edwards Aquifer Protection Program 30 TAC Chapter 213 (effective 05/01/2008)

Water Pollution Abatement Plans and Modifications

Contributing Zone Plans and Modifications

<i>Project</i>	<i>Project Area in Acres</i>	<i>Fee</i>
One Single Family Residential Dwelling	< 5	\$650
Multiple Single Family Residential and Parks	< 5	\$1,500
	5 < 10	\$3,000
	10 < 40	\$4,000
	40 < 100	\$6,500
	100 < 500	\$8,000
	≥ 500	\$10,000
Non-residential (Commercial, industrial, institutional, multi-family residential, schools, and other sites where regulated activities will occur)	< 1	\$3,000
	1 < 5	\$4,000
	5 < 10	\$5,000
	10 < 40	\$6,500
	40 < 100	\$8,000
	≥ 100	\$10,000

Organized Sewage Collection Systems and Modifications

<i>Project</i>	<i>Cost per Linear Foot</i>	<i>Minimum Fee- Maximum Fee</i>
Sewage Collection Systems	\$0.50	\$650 - \$6,500

Underground and Aboveground Storage Tank System Facility Plans and Modifications

<i>Project</i>	<i>Cost per Tank or Piping System</i>	<i>Minimum Fee- Maximum Fee</i>
Underground and Aboveground Storage Tank Facility	\$650	\$650 - \$6,500

Exception Requests

<i>Project</i>	<i>Fee</i>
Exception Request	\$500

Extension of Time Requests

<i>Project</i>	<i>Fee</i>
Extension of Time Request	\$150

Core Data Form (TCEQ-10400)



TCEQ Use Only

TCEQ Core Data Form

For detailed instructions regarding completion of this form, please read the Core Data Form Instructions or call 512-239-5175.

SECTION I: General Information

1. Reason for Submission (If other is checked please describe in space provided.)		
<input checked="" type="checkbox"/> New Permit, Registration or Authorization (Core Data Form should be submitted with the program application.)		
<input type="checkbox"/> Renewal (Core Data Form should be submitted with the renewal form)	<input type="checkbox"/> Other	
2. Customer Reference Number (if issued)	Follow this link to search for CN or RN numbers in Central Registry**	3. Regulated Entity Reference Number (if issued)
CN		RN

SECTION II: Customer Information

4. General Customer Information		5. Effective Date for Customer Information Updates (mm/dd/yyyy)	
<input checked="" type="checkbox"/> New Customer		<input type="checkbox"/> Update to Customer Information	
<input type="checkbox"/> Change in Legal Name (Verifiable with the Texas Secretary of State or Texas Comptroller of Public Accounts)		<input type="checkbox"/> Change in Regulated Entity Ownership	
The Customer Name submitted here may be updated automatically based on what is current and active with the Texas Secretary of State (SOS) or Texas Comptroller of Public Accounts (CPA).			
6. Customer Legal Name (If an individual, print last name first: eg: Doe, John)		If new Customer, enter previous Customer below:	
Marshall and Bulverde, LLC			
7. TX SOS/CPA Filing Number	8. TX State Tax ID (11 digits)	9. Federal Tax ID (9 digits)	10. DUNS Number (if applicable)
803843003			
11. Type of Customer:	<input type="checkbox"/> Corporation	<input type="checkbox"/> Individual	Partnership: <input type="checkbox"/> General <input type="checkbox"/> Limited
Government: <input type="checkbox"/> City <input type="checkbox"/> County <input type="checkbox"/> Federal <input type="checkbox"/> State <input type="checkbox"/> Other	<input type="checkbox"/> Sole Proprietorship	<input checked="" type="checkbox"/> Other: LLC	
12. Number of Employees		13. Independently Owned and Operated?	
<input checked="" type="checkbox"/> 0-20 <input type="checkbox"/> 21-100 <input type="checkbox"/> 101-250 <input type="checkbox"/> 251-500 <input type="checkbox"/> 501 and higher		<input checked="" type="checkbox"/> Yes <input type="checkbox"/> No	
14. Customer Role (Proposed or Actual) – as it relates to the Regulated Entity listed on this form. Please check one of the following			
<input type="checkbox"/> Owner		<input type="checkbox"/> Operator	
<input type="checkbox"/> Occupational Licensee		<input checked="" type="checkbox"/> Owner & Operator	
<input type="checkbox"/> Responsible Party		<input type="checkbox"/> Voluntary Cleanup Applicant	
<input type="checkbox"/> Other:			
15. Mailing Address:	7410 Blanco Road		
	Suite 225		
	City	San Antonio	State TX ZIP 78216 ZIP + 4 4363
16. Country Mailing Information (if outside USA)		17. E-Mail Address (if applicable)	
18. Telephone Number	19. Extension or Code	20. Fax Number (if applicable)	
(210) 960- 5540		() -	

SECTION III: Regulated Entity Information

21. General Regulated Entity Information (If 'New Regulated Entity' is selected below this form should be accompanied by a permit application)	
<input checked="" type="checkbox"/> New Regulated Entity <input type="checkbox"/> Update to Regulated Entity Name <input type="checkbox"/> Update to Regulated Entity Information	
The Regulated Entity Name submitted may be updated in order to meet TCEQ Agency Data Standards (removal of organizational endings such as Inc, LP, or LLC).	
22. Regulated Entity Name (Enter name of the site where the regulated action is taking place.)	
Halftime 1	

23. Street Address of the Regulated Entity: <i>(No PO Boxes)</i>	3125 Summit Church Road							
	City	San Antonio	State	TX	ZIP	78259	ZIP + 4	2189
24. County	Bexar							

Enter Physical Location Description if no street address is provided.

25. Description to Physical Location:	NW corner of Summit Church Road and Bulverde Road								
26. Nearest City	San Antonio				State	TX	Nearest ZIP Code		78261
27. Latitude (N) In Decimal:	29.66306			28. Longitude (W) In Decimal:	- 98.43639				
Degrees	Minutes	Seconds	Degrees	Minutes	Seconds				
29	39	47	98	26	11				
29. Primary SIC Code (4 digits)	30. Secondary SIC Code (4 digits)		31. Primary NAICS Code (5 or 6 digits)		32. Secondary NAICS Code (5 or 6 digits)				
5983	5541		457110		N/A				
33. What is the Primary Business of this entity? <i>(Do not repeat the SIC or NAICS description.)</i>									
Convenience Store with Fuel Sales									
34. Mailing Address:	7410 Blanco Road								
	Suite 225								
	City	San Antonio	State	TX	ZIP	78216	ZIP + 4	4363	
35. E-Mail Address:		kns3big@gmail.com							
36. Telephone Number			37. Extension or Code		38. Fax Number <i>(if applicable)</i>				
(210) 960-5540					() -				

39. TCEQ Programs and ID Numbers Check all Programs and write in the permits/registration numbers that will be affected by the updates submitted on this form. See the Core Data Form instructions for additional guidance.

<input type="checkbox"/> Dam Safety	<input type="checkbox"/> Districts	<input checked="" type="checkbox"/> Edwards Aquifer	<input type="checkbox"/> Emissions Inventory Air	<input type="checkbox"/> Industrial Hazardous Waste
<input type="checkbox"/> Municipal Solid Waste	<input type="checkbox"/> New Source Review Air	<input type="checkbox"/> OSSF	<input checked="" type="checkbox"/> Petroleum Storage Tank	<input type="checkbox"/> PWS
<input type="checkbox"/> Sludge	<input type="checkbox"/> Storm Water	<input type="checkbox"/> Title V Air	<input type="checkbox"/> Tires	<input type="checkbox"/> Used Oil
<input type="checkbox"/> Voluntary Cleanup	<input type="checkbox"/> Waste Water	<input type="checkbox"/> Wastewater Agriculture	<input type="checkbox"/> Water Rights	<input type="checkbox"/> Other:

SECTION IV: Preparer Information

40. Name:	UP Engineering + Surveying	41. Title:	Engineer
42. Telephone Number	43. Ext./Code	44. Fax Number	45. E-Mail Address
(210) 774-5504		() -	

SECTION V: Authorized Signature

46. By my signature below, I certify, to the best of my knowledge, that the information provided in this form is true and complete, and that I have signature authority to submit this form on behalf of the entity specified in Section II, Field 6 and/or as required for the updates to the ID numbers identified in field 39.

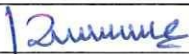
Company:	Marshall and Bulverde, LLC	Job Title:	President/Owner
Name <i>(In Print)</i> :	Karim Ali	Phone:	(210) 960-5504
Signature:		Date:	5/16/2023