

■ Contributing Zone Plan

Lemon Creek Ranch Multifamily
9405 Dietz Elkhorn Road,
San Antonio, ETJ, Texas
Bexar County

August 2023

Project Owner:

VEP Lemon Creek LP
1723 N Loop 1604 E, Suite 204
San Antonio, TX 78232



Prepared By:

Kimley»»Horn

10101 Reunion Place, Suite 400
San Antonio, TX 78216
Tel: (210) 541-9166

Texas Commission on Environmental Quality

Edwards Aquifer Application Cover Page

Our Review of Your Application

The Edwards Aquifer Program staff conducts an administrative and technical review of all applications. The turnaround time for administrative review can be up to 30 days as outlined in 30 TAC 213.4(e). Generally administrative completeness is determined during the intake meeting or within a few days of receipt. The turnaround time for technical review of an administratively complete Edwards Aquifer application is 90 days as outlined in 30 TAC 213.4(e). Please know that the review and approval time is directly impacted by the quality and completeness of the initial application that is received. In order to conduct a timely review, it is imperative that the information provided in an Edwards Aquifer application include final plans, be accurate, complete, and in compliance with [30 TAC 213](#).

Administrative Review

1. [Edwards Aquifer applications](#) must be deemed administratively complete before a technical review can begin. To be considered administratively complete, the application must contain completed forms and attachments, provide the requested information, and meet all the site plan requirements. The submitted application and plan sheets should be final plans. Please submit one full-size set of plan sheets with the original application, and half-size sets with the additional copies.

To ensure that all applicable documents are included in the application, the program has developed tools to guide you and web pages to provide all forms, checklists, and guidance. Please visit the below website for assistance: <http://www.tceq.texas.gov/field/eapp>.

2. This Edwards Aquifer Application Cover Page form (certified by the applicant or agent) must be included in the application and brought to the administrative review meeting.
3. Administrative reviews are scheduled with program staff who will conduct the review. Applicants or their authorized agent should call the appropriate regional office, according to the county in which the project is located, to schedule a review. The average meeting time is one hour.
4. In the meeting, the application is examined for administrative completeness. Deficiencies will be noted by staff and emailed or faxed to the applicant and authorized agent at the end of the meeting, or shortly after. Administrative deficiencies will cause the application to be deemed incomplete and returned.

An appointment should be made to resubmit the application. The application is re-examined to ensure all deficiencies are resolved. The application will only be deemed administratively complete when all administrative deficiencies are addressed.

5. If an application is received by mail, courier service, or otherwise submitted without a review meeting, the administrative review will be conducted within 30 days. The applicant and agent will be contacted with the results of the administrative review. If the application is found to be administratively incomplete, it can be retrieved from the regional office or returned by regular mail. If returned by mail, the regional office may require arrangements for return shipping.
6. If the geologic assessment was completed before October 1, 2004 and the site contains “possibly sensitive” features, the assessment must be updated in accordance with the *Instructions to Geologists* (TCEQ-0585 Instructions).

Technical Review

1. When an application is deemed administratively complete, the technical review period begins. The regional office will distribute copies of the application to the identified affected city, county, and groundwater conservation district whose jurisdiction includes the subject site. These entities and the public have 30 days to provide comments on the application to the regional office. All comments received are reviewed by TCEQ.
2. A site assessment is usually conducted as part of the technical review, to evaluate the geologic assessment and observe existing site conditions. The site must be accessible to our staff. The site boundaries should be

clearly marked, features identified in the geologic assessment should be flagged, roadways marked and the alignment of the Sewage Collection System and manholes should be staked at the time the application is submitted. If the site is not marked the application may be returned.

3. We evaluate the application for technical completeness and contact the applicant and agent via Notice of Deficiency (NOD) to request additional information and identify technical deficiencies. There are two deficiency response periods available to the applicant. There are 14 days to resolve deficiencies noted in the first NOD. If a second NOD is issued, there is an additional 14 days to resolve deficiencies. If the response to the second notice is not received, is incomplete or inadequate, or provides new information that is incomplete or inadequate, the application must be withdrawn or will be denied. Please note that because the technical review is underway, whether the application is withdrawn or denied **the application fee will be forfeited**.
4. The program has 90 calendar days to complete the technical review of the application. If the application is technically adequate, such that it complies with the Edwards Aquifer rules, and is protective of the Edwards Aquifer during and after construction, an approval letter will be issued. Construction or other regulated activity may not begin until an approval is issued.

Mid-Review Modifications

It is important to have final site plans prior to beginning the permitting process with TCEQ to avoid delays.

Occasionally, circumstances arise where you may have significant design and/or site plan changes after your Edwards Aquifer application has been deemed administratively complete by TCEQ. This is considered a “Mid-Review Modification”. Mid-Review Modifications may require redistribution of an application that includes the proposed modifications for public comment.

If you are proposing a Mid-Review Modification, two options are available:

- If the technical review has begun your application can be denied/withdrawn, your fees will be forfeited, and the plan will have to be resubmitted.
- TCEQ can continue the technical review of the application as it was submitted, and a modification application can be submitted at a later time.

If the application is denied/withdrawn, the resubmitted application will be subject to the administrative and technical review processes and will be treated as a new application. The application will be redistributed to the affected jurisdictions.

Please contact the regional office if you have questions. If your project is located in Williamson, Travis, or Hays County, contact TCEQ’s Austin Regional Office at 512-339-2929. If your project is in Comal, Bexar, Medina, Uvalde, or Kinney County, contact TCEQ’s San Antonio Regional Office at 210-490-3096

Please fill out all required fields below and submit with your application.

1. Regulated Entity Name: Lemon Creek Ranch Multifamily				2. Regulated Entity No.: NA					
3. Customer Name: VEP Lemon Creek LP				4. Customer No.: NA					
5. Project Type: (Please circle/check one)	New		Modification			Extension		Exception	
6. Plan Type: (Please circle/check one)	WPAP	CZP	SCS	UST	AST	EXP	EXT	Technical Clarification	Optional Enhanced Measures
7. Land Use: (Please circle/check one)	Residential		Non-residential			8. Site (acres):		12.17 AC.	
9. Application Fee:	\$6500.00		10. Permanent BMP(s):			Contech Jellyfish Filter Vaults			
11. SCS (Linear Ft.):	NA		12. AST/UST (No. Tanks):			NA			
13. County:	Bexar		14. Watershed:			Cibolo Creek			

Application Distribution

Instructions: Use the table below to determine the number of applications required. One original and one copy of the application, plus additional copies (as needed) for each affected incorporated city, county, and groundwater conservation district are required. Linear projects or large projects, which cross into multiple jurisdictions, can require additional copies. Refer to the “Texas Groundwater Conservation Districts within the EAPP Boundaries” map found at:

http://www.tceq.texas.gov/assets/public/compliance/field_ops/eapp/EAPP%20GWCD%20map.pdf

For more detailed boundaries, please contact the conservation district directly.

Austin Region			
County:	Hays	Travis	Williamson
Original (1 req.)	—	—	—
Region (1 req.)	—	—	—
County(ies)	—	—	—
Groundwater Conservation District(s)	<input type="checkbox"/> Edwards Aquifer Authority <input type="checkbox"/> Barton Springs/ Edwards Aquifer <input type="checkbox"/> Hays Trinity <input type="checkbox"/> Plum Creek	<input type="checkbox"/> Barton Springs/ Edwards Aquifer	NA
City(ies) Jurisdiction	<input type="checkbox"/> Austin <input type="checkbox"/> Buda <input type="checkbox"/> Dripping Springs <input type="checkbox"/> Kyle <input type="checkbox"/> Mountain City <input type="checkbox"/> San Marcos <input type="checkbox"/> Wimberley <input type="checkbox"/> Woodcreek	<input type="checkbox"/> Austin <input type="checkbox"/> Bee Cave <input type="checkbox"/> Pflugerville <input type="checkbox"/> Rollingwood <input type="checkbox"/> Round Rock <input type="checkbox"/> Sunset Valley <input type="checkbox"/> West Lake Hills	<input type="checkbox"/> Austin <input type="checkbox"/> Cedar Park <input type="checkbox"/> Florence <input type="checkbox"/> Georgetown <input type="checkbox"/> Jerrell <input type="checkbox"/> Leander <input type="checkbox"/> Liberty Hill <input type="checkbox"/> Pflugerville <input type="checkbox"/> Round Rock

San Antonio Region					
County:	Bexar	Comal	Kinney	Medina	Uvalde
Original (1 req.)	<input checked="" type="checkbox"/>	—	—	—	—
Region (1 req.)	<input checked="" type="checkbox"/>	—	—	—	—
County(ies)	<input checked="" type="checkbox"/>	—	—	—	—
Groundwater Conservation District(s)	<input type="checkbox"/> Edwards Aquifer Authority <input checked="" type="checkbox"/> Trinity-Glen Rose	<input type="checkbox"/> Edwards Aquifer Authority	<input type="checkbox"/> Kinney	<input type="checkbox"/> EAA Medina	<input type="checkbox"/> EAA Uvalde
City(ies) Jurisdiction	<input type="checkbox"/> Castle Hills <input type="checkbox"/> Fair Oaks Ranch <input type="checkbox"/> Helotes <input type="checkbox"/> Hill Country Village <input type="checkbox"/> Hollywood Park <input checked="" type="checkbox"/> San Antonio (SAWS) <input type="checkbox"/> Shavano Park	<input type="checkbox"/> Bulverde <input type="checkbox"/> Fair Oaks Ranch <input type="checkbox"/> Garden Ridge <input type="checkbox"/> New Braunfels <input type="checkbox"/> Schertz	NA	<input type="checkbox"/> San Antonio ETJ (SAWS)	NA

I certify that to the best of my knowledge, that the application is complete and accurate. This application is hereby submitted to TCEQ for administrative review and technical review.

Aaron Parenica, P.E.

Print Name of Customer/Authorized Agent

Signature of Customer/Authorized Agent

7/13/2023

Date

****FOR TCEQ INTERNAL USE ONLY****

Date(s) Reviewed:		Date Administratively Complete:	
Received From:		Correct Number of Copies:	
Received By:		Distribution Date:	
EAPP File Number:		Complex:	
Admin. Review(s) (No.):		No. AR Rounds:	
Delinquent Fees (Y/N):		Review Time Spent:	
Lat./Long. Verified:		SOS Customer Verification:	
Agent Authorization Complete/Notarized (Y/N):		Fee Check:	Payable to TCEQ (Y/N):
Core Data Form Complete (Y/N):			Signed (Y/N):
Core Data Form Incomplete Nos.:			Less than 90 days old (Y/N):

Contributing Zone Plan Application

Texas Commission on Environmental Quality

for Regulated Activities on the Contributing Zone to the Edwards Aquifer and Relating to 30 TAC §213.24(1), Effective June 1, 1999

To ensure that the application is administratively complete, confirm that all fields in the form are complete, verify that all requested information is provided, consistently reference the same site and contact person in all forms in the application, and ensure forms are signed by the appropriate party.

Note: Including all the information requested in the form and attachments contributes to more streamlined technical reviews.

Signature

To the best of my knowledge, the responses to this form accurately reflect all information requested concerning the proposed regulated activities and methods to protect the Edwards Aquifer. This **Contributing Zone Plan Application** is hereby submitted for TCEQ review and Executive Director approval. The application was prepared by:

Print Name of Customer/Agent: Aaron Parenica

Date: 6/30/2023

Signature of Customer/Agent:



Regulated Entity Name: Lemon Creek Ranch Multifamily

Project Information

1. County: Bexar
2. Stream Basin: Cibolo Creek
3. Groundwater Conservation District (if applicable): Trinity-Glen Rose
4. Customer (Applicant):

Contact Person: Charlie Malmberg

Entity: VEP Lemon Creek, LP

Mailing Address: 1723 N. Loop 1604 E, Suite 240

City, State: San Antonio, Texas

Telephone: (210) 824-4242

Email Address: charlie@valcorcre.com

Zip: 78232

Fax: _____

5. Agent/Representative (If any):

Contact Person: Aaron Parenica

Entity: Kimley-Horn and Associates, Inc.

Mailing Address: 10101 Reunion Place, Suite 400

City, State: San Antonio, Texas

Zip: 78216

Telephone: (602) 309-7099

Fax: _____

Email Address: aaron.parenica@kimley-horn.com

6. Project Location:

- The project site is located inside the city limits of _____.
- The project site is located outside the city limits but inside the ETJ (extra-territorial jurisdiction) of San Antonio, Texas
- The project site is not located within any city's limits or ETJ.

7. The location of the project site is described below. Sufficient detail and clarity has been provided so that the TCEQ's Regional staff can easily locate the project and site boundaries for a field investigation.

The subject site is a 12.17 acre tract located east of IH-10 between Balcones Creek and Dietz-Elkhorn Road within the ETJ of San Antonio, Bexar County, Texas.

8. **Attachment A - Road Map.** A road map showing directions to and the location of the project site is attached. The map clearly shows the boundary of the project site.

9. **Attachment B - USGS Quadrangle Map.** A copy of the official 7 ½ minute USGS Quadrangle Map (Scale: 1" = 2000") is attached. The map(s) clearly show:

- Project site boundaries.
- USGS Quadrangle Name(s).

10. **Attachment C - Project Narrative.** A detailed narrative description of the proposed project is attached. The project description is consistent throughout the application and contains, at a minimum, the following details:

- Area of the site
- Offsite areas
- Impervious cover
- Permanent BMP(s)
- Proposed site use
- Site history
- Previous development
- Area(s) to be demolished

11. Existing project site conditions are noted below:

- Existing commercial site
- Existing industrial site
- Existing residential site

- Existing paved and/or unpaved roads
- Undeveloped (Cleared)
- Undeveloped (Undisturbed/Not cleared)
- Other: _____

12. The type of project is:

- Residential: # of Lots: _____
- Residential: # of Living Unit Equivalents: 349
- Commercial
- Industrial
- Other: _____

13. Total project area (size of site): 12.17 Acres

Total disturbed area: 12.17 Acres

14. Estimated projected population: N/A

15. The amount and type of impervious cover expected after construction is complete is shown below:

Table 1 - Impervious Cover TOTAL IMPERVIOUS AREA FOR A1 AND B1

<i>Impervious Cover of Proposed Project</i>	<i>Sq. Ft.</i>	<i>Sq. Ft./Acre</i>	<i>Acres</i>
Structures/Rooftops	148,000	÷ 43,560 =	±3.40
Parking	89,000	÷ 43,560 =	±2.04
Other paved surfaces	135,000	÷ 43,560 =	±3.10
Total Impervious Cover	372,000	÷ 43,560 =	±8.54

Total Impervious Cover $\pm 8.54 \div \text{Total Acreage} \pm 12.17 \times 100 = \pm 71$ % Impervious Cover

16. **Attachment D - Factors Affecting Surface Water Quality.** A detailed description of all factors that could affect surface water quality is attached. If applicable, this includes the location and description of any discharge associated with industrial activity other than construction.

17. Only inert materials as defined by 30 TAC 330.2 will be used as fill material.

For Road Projects Only

Complete questions 18 - 23 if this application is exclusively for a road project.

N/A

18. Type of project:

- TXDOT road project.
- County road or roads built to county specifications.
- City thoroughfare or roads to be dedicated to a municipality.
- Street or road providing access to private driveways.

19. Type of pavement or road surface to be used:

- Concrete
- Asphaltic concrete pavement
- Other: _____

20. Right of Way (R.O.W.):

Length of R.O.W.: _____ feet.

Width of R.O.W.: _____ feet.

$L \times W = \text{_____ Ft}^2 \div 43,560 \text{ Ft}^2/\text{Acre} = \text{_____ acres.}$

21. Pavement Area:

Length of pavement area: _____ feet.

Width of pavement area: _____ feet.

$L \times W = \text{_____ Ft}^2 \div 43,560 \text{ Ft}^2/\text{Acre} = \text{_____ acres.}$

Pavement area _____ acres \div R.O.W. area _____ acres $\times 100 = \text{_____ \%}$ impervious cover.

22. A rest stop will be included in this project.

A rest stop will not be included in this project.

23. Maintenance and repair of existing roadways that do not require approval from the TCEQ Executive Director. Modifications to existing roadways such as widening roads/adding shoulders totaling more than one-half (1/2) the width of one (1) existing lane require prior approval from the TCEQ.

Stormwater to be generated by the Proposed Project

24. **Attachment E - Volume and Character of Stormwater.** A detailed description of the volume (quantity) and character (quality) of the stormwater runoff which is expected to occur from the proposed project is attached. The estimates of stormwater runoff quality and quantity are based on area and type of impervious cover. Include the runoff coefficient of the site for both pre-construction and post-construction conditions.

Wastewater to be generated by the Proposed Project

25. Wastewater is to be discharged in the contributing zone. Requirements under 30 TAC §213.6(c) relating to Wastewater Treatment and Disposal Systems have been satisfied.

N/A

26. Wastewater will be disposed of by:

On-Site Sewage Facility (OSSF/Septic Tank):

Attachment F - Suitability Letter from Authorized Agent. An on-site sewage facility will be used to treat and dispose of the wastewater from this site. The appropriate licensing authority's (authorized agent) written approval is attached. It states that the land is suitable for the use of private sewage facilities and will meet or exceed the requirements for on-site sewage facilities as specified under 30 TAC Chapter 285 relating to On-site Sewage Facilities.

Each lot in this project/development is at least one (1) acre (43,560 square feet) in size. The system will be designed by a licensed professional engineer or registered sanitarian and installed by a licensed installer in compliance with 30 TAC Chapter 285.

Sewage Collection System (Sewer Lines):

The sewage collection system will convey the wastewater to the _____ (name) Treatment Plant. The treatment facility is:

Steven M. Clouse Water Recycling Center

Existing.

Proposed.

N/A

Permanent Aboveground Storage Tanks(ASTs) ≥ 500 Gallons

Complete questions 27 - 33 if this project includes the installation of AST(s) with volume(s) greater than or equal to 500 gallons.

N/A

27. Tanks and substance stored:

Table 2 - Tanks and Substance Storage

<i>AST Number</i>	<i>Size (Gallons)</i>	<i>Substance to be Stored</i>	<i>Tank Material</i>
1			
2			
3			
4			
5			

Total x 1.5 = _____ Gallons

28. The AST will be placed within a containment structure that is sized to capture one and one-half (1 1/2) times the storage capacity of the system. For facilities with more than

one tank system, the containment structure is sized to capture one and one-half (1 1/2) times the cumulative storage capacity of all systems.

- Attachment G - Alternative Secondary Containment Methods.** Alternative methods for providing secondary containment are proposed. Specifications showing equivalent protection for the Edwards Aquifer are attached.

29. Inside dimensions and capacity of containment structure(s):

Table 3 - Secondary Containment

<i>Length (L)(Ft.)</i>	<i>Width(W)(Ft.)</i>	<i>Height (H)(Ft.)</i>	<i>L x W x H = (Ft3)</i>	<i>Gallons</i>

Total: _____ Gallons

30. Piping:

- All piping, hoses, and dispensers will be located inside the containment structure.
- Some of the piping to dispensers or equipment will extend outside the containment structure.
- The piping will be aboveground
- The piping will be underground

31. The containment area must be constructed of and in a material impervious to the substance(s) being stored. The proposed containment structure will be constructed of: _____.

32. **Attachment H - AST Containment Structure Drawings.** A scaled drawing of the containment structure is attached that shows the following:

- Interior dimensions (length, width, depth and wall and floor thickness).
- Internal drainage to a point convenient for the collection of any spillage.
- Tanks clearly labeled
- Piping clearly labeled
- Dispenser clearly labeled

33. Any spills must be directed to a point convenient for collection and recovery. Spills from storage tank facilities must be removed from the controlled drainage area for disposal within 24 hours of the spill.

- In the event of a spill, any spillage will be removed from the containment structure within 24 hours of the spill and disposed of properly.

- In the event of a spill, any spillage will be drained from the containment structure through a drain and valve within 24 hours of the spill and disposed of properly. The drain and valve system are shown in detail on the scaled drawing.

Site Plan Requirements

Items 34 - 46 must be included on the Site Plan.

34. The Site Plan must have a minimum scale of 1" = 400'.
Site Plan Scale: 1" = 60' .
35. 100-year floodplain boundaries:
- Some part(s) of the project site is located within the 100-year floodplain. The floodplain is shown and labeled.
- No part of the project site is located within the 100-year floodplain.
The 100-year floodplain boundaries are based on the following specific (including date of material) sources(s): 06/07/2022.
36. The layout of the development is shown with existing and finished contours at appropriate, but not greater than ten-foot contour intervals. Lots, recreation centers, buildings, roads, etc. are shown on the site plan.
- The layout of the development is shown with existing contours at appropriate, but not greater than ten-foot contour intervals. Finished topographic contours will not differ from the existing topographic configuration and are not shown. Lots, recreation centers, buildings, roads, etc. are shown on the site plan.
37. A drainage plan showing all paths of drainage from the site to surface streams.
38. The drainage patterns and approximate slopes anticipated after major grading activities.
39. Areas of soil disturbance and areas which will not be disturbed.
40. Locations of major structural and nonstructural controls. These are the temporary and permanent best management practices.
41. Locations where soil stabilization practices are expected to occur.
42. Surface waters (including wetlands).
 N/A
43. Locations where stormwater discharges to surface water.
 There will be no discharges to surface water.
44. Temporary aboveground storage tank facilities.
 Temporary aboveground storage tank facilities will not be located on this site.

45. Permanent aboveground storage tank facilities.
 Permanent aboveground storage tank facilities will not be located on this site.
46. Legal boundaries of the site are shown.

Permanent Best Management Practices (BMPs)

Practices and measures that will be used during and after construction is completed.

47. Permanent BMPs and measures must be implemented to control the discharge of pollution from regulated activities after the completion of construction.
 N/A
48. These practices and measures have been designed, and will be constructed, operated, and maintained to insure that 80% of the incremental increase in the annual mass loading of total suspended solids (TSS) from the site caused by the regulated activity is removed. These quantities have been calculated in accordance with technical guidance prepared or accepted by the executive director.
 The TCEQ Technical Guidance Manual (TGM) was used to design permanent BMPs and measures for this site.
 A technical guidance other than the TCEQ TGM was used to design permanent BMPs and measures for this site. The complete citation for the technical guidance that was used is: _____.
 N/A
49. Owners must insure that permanent BMPs and measures are constructed and function as designed. A Texas Licensed Professional Engineer must certify in writing that the permanent BMPs or measures were constructed as designed. The certification letter must be submitted to the appropriate regional office within 30 days of site completion.
 N/A
50. Where a site is used for low density single-family residential development and has 20 % or less impervious cover, other permanent BMPs are not required. This exemption from permanent BMPs must be recorded in the county deed records, with a notice that if the percent impervious cover increases above 20% or land use changes, the exemption for the whole site as described in the property boundaries required by 30 TAC §213.4(g) (relating to Application Processing and Approval), may no longer apply and the property owner must notify the appropriate regional office of these changes.
 The site will be used for low density single-family residential development and has 20% or less impervious cover.
 The site will be used for low density single-family residential development but has more than 20% impervious cover.
 The site will not be used for low density single-family residential development.

51. The executive director may waive the requirement for other permanent BMPs for multi-family residential developments, schools, or small business sites where 20% or less impervious cover is used at the site. This exemption from permanent BMPs must be recorded in the county deed records, with a notice that if the percent impervious cover increases above 20% or land use changes, the exemption for the whole site as described in the property boundaries required by 30 TAC §213.4(g) (relating to Application Processing and Approval), may no longer apply and the property owner must notify the appropriate regional office of these changes.

- Attachment I - 20% or Less Impervious Cover Waiver.** The site will be used for multi-family residential developments, schools, or small business sites and has 20% or less impervious cover. A request to waive the requirements for other permanent BMPs and measures is attached.
- The site will be used for multi-family residential developments, schools, or small business sites but has more than 20% impervious cover.
- The site will not be used for multi-family residential developments, schools, or small business sites.

52. **Attachment J - BMPs for Upgradient Stormwater.**

- A description of the BMPs and measures that will be used to prevent pollution of surface water, groundwater, or stormwater that originates upgradient from the site and flows across the site is attached.
- No surface water, groundwater or stormwater originates upgradient from the site and flows across the site, and an explanation is attached.
- Permanent BMPs or measures are not required to prevent pollution of surface water, groundwater, or stormwater that originates upgradient from the site and flows across the site, and an explanation is attached.

53. **Attachment K - BMPs for On-site Stormwater.**

- A description of the BMPs and measures that will be used to prevent pollution of surface water or groundwater that originates on-site or flows off the site, including pollution caused by contaminated stormwater runoff from the site is attached.
- Permanent BMPs or measures are not required to prevent pollution of surface water or groundwater that originates on-site or flows off the site, including pollution caused by contaminated stormwater runoff, and an explanation is attached.

54. **Attachment L - BMPs for Surface Streams.** A description of the BMPs and measures that prevent pollutants from entering surface streams is attached.

N/A

55. **Attachment M - Construction Plans.** Construction plans and design calculations for the proposed permanent BMPs and measures have been prepared by or under the direct supervision of a Texas Licensed Professional Engineer, and are signed, sealed, and dated. Construction plans for the proposed permanent BMPs and measures are

attached and include: Design calculations, TCEQ Construction Notes, all proposed structural plans and specifications, and appropriate details.

N/A

56. **Attachment N - Inspection, Maintenance, Repair and Retrofit Plan.** A site and BMP specific plan for the inspection, maintenance, repair, and, if necessary, retrofit of the permanent BMPs and measures is attached. The plan fulfills all of the following:

Prepared and certified by the engineer designing the permanent BMPs and measures

Signed by the owner or responsible party

Outlines specific procedures for documenting inspections, maintenance, repairs, and, if necessary, retrofit.

Contains a discussion of record keeping procedures

N/A

57. **Attachment O - Pilot-Scale Field Testing Plan.** Pilot studies for BMPs that are not recognized by the Executive Director require prior approval from the TCEQ. A plan for pilot-scale field testing is attached.

N/A

58. **Attachment P - Measures for Minimizing Surface Stream Contamination.** A description of the measures that will be used to avoid or minimize surface stream contamination and changes in the way in which water enters a stream as a result of the construction and development is attached. The measures address increased stream flashing, the creation of stronger flows and in-stream velocities, and other in-stream effects caused by the regulated activity, which increase erosion that result in water quality degradation.

N/A

Responsibility for Maintenance of Permanent BMPs and Measures after Construction is Complete.

59. The applicant is responsible for maintaining the permanent BMPs after construction until such time as the maintenance obligation is either assumed in writing by another entity having ownership or control of the property (such as without limitation, an owner's association, a new property owner or lessee, a district, or municipality) or the ownership of the property is transferred to the entity. Such entity shall then be responsible for maintenance until another entity assumes such obligations in writing or ownership is transferred.
60. A copy of the transfer of responsibility must be filed with the executive director at the appropriate regional office within 30 days of the transfer if the site is for use as a multiple single-family residential development, a multi-family residential development,

or a non-residential development such as commercial, industrial, institutional, schools, and other sites where regulated activities occur.

Administrative Information

61. Submit one (1) original and one (1) copy of the application, plus additional copies as needed for each affected incorporated city, groundwater conservation district, and county in which the project will be located. The TCEQ will distribute the additional copies to these jurisdictions.
62. Any modification of this Contributing Zone Plan may require TCEQ review and Executive Director approval prior to construction, and may require submission of a revised application, with appropriate fees.
63. The site description, controls, maintenance, and inspection requirements for the storm water pollution prevention plan (SWPPP) developed under the EPA NPDES general permits for stormwater discharges have been submitted to fulfill paragraphs 30 TAC §213.24(1-5) of the technical report. All requirements of 30 TAC §213.24(1-5) have been met by the SWPPP document.
 The Temporary Stormwater Section (TCEQ-0602) is included with the application.

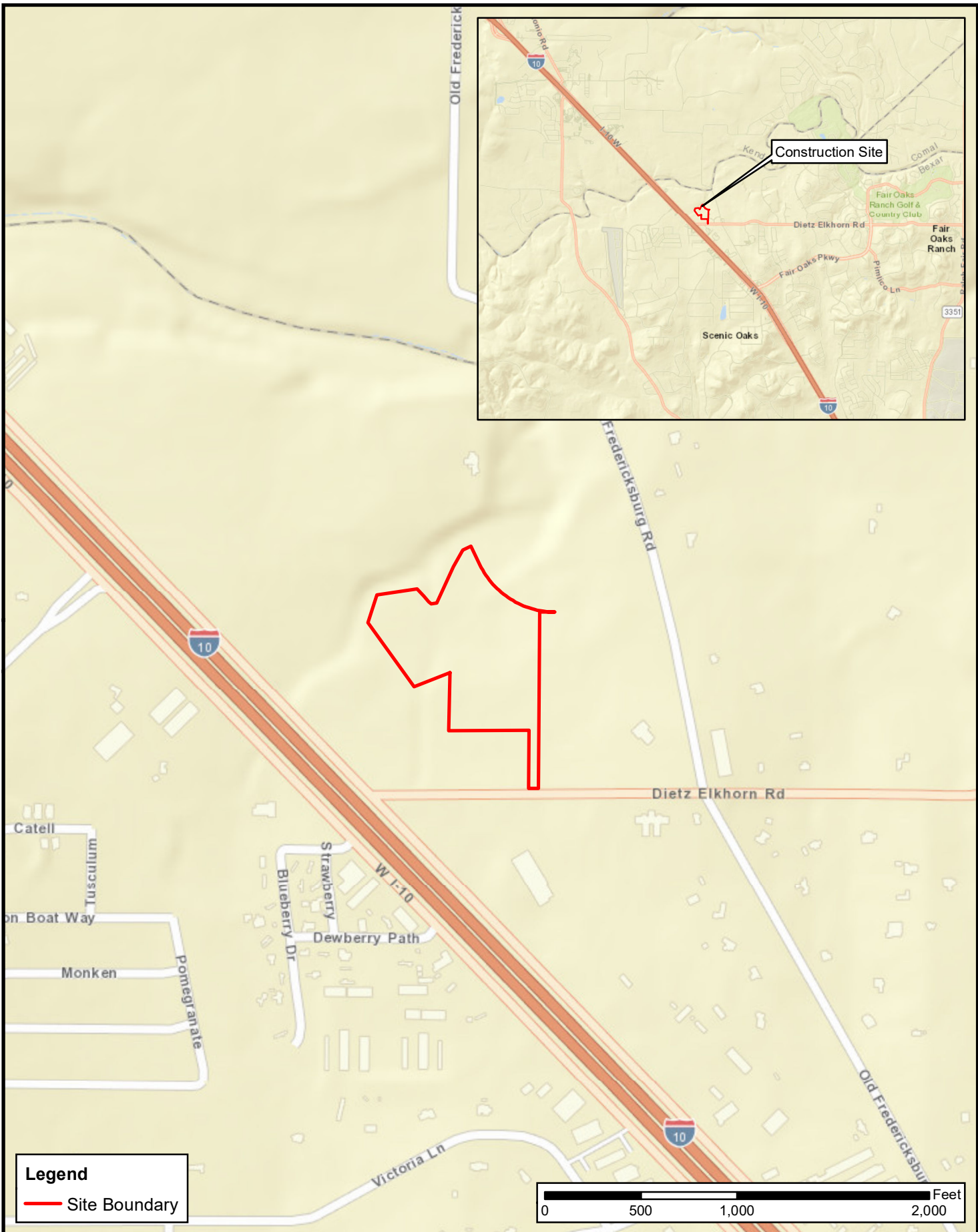

Legend
 — Site Boundary

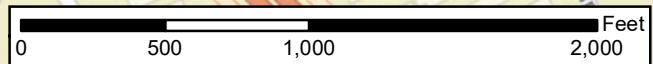

SHEET 1 OF 2 SHEETS	DATE:	03/28/2022
	DESIGN:	JWG
	DRAWN:	JWG
	CHECKED:	AJP
	KHA NO.:	064557101

LOCATION MAP
Attachment A

CZP
 Lemon Creek Ranch
 Garden Multi-Family
 San Antonio ETJ, Bexar County, Texas



Kimley»Horn

This product is for informational purposes and may not have been prepared for or be suitable for legal, engineering, or surveying purposes. It does not represent an on-the-ground survey and represents only the approximate relative location of property boundaries.

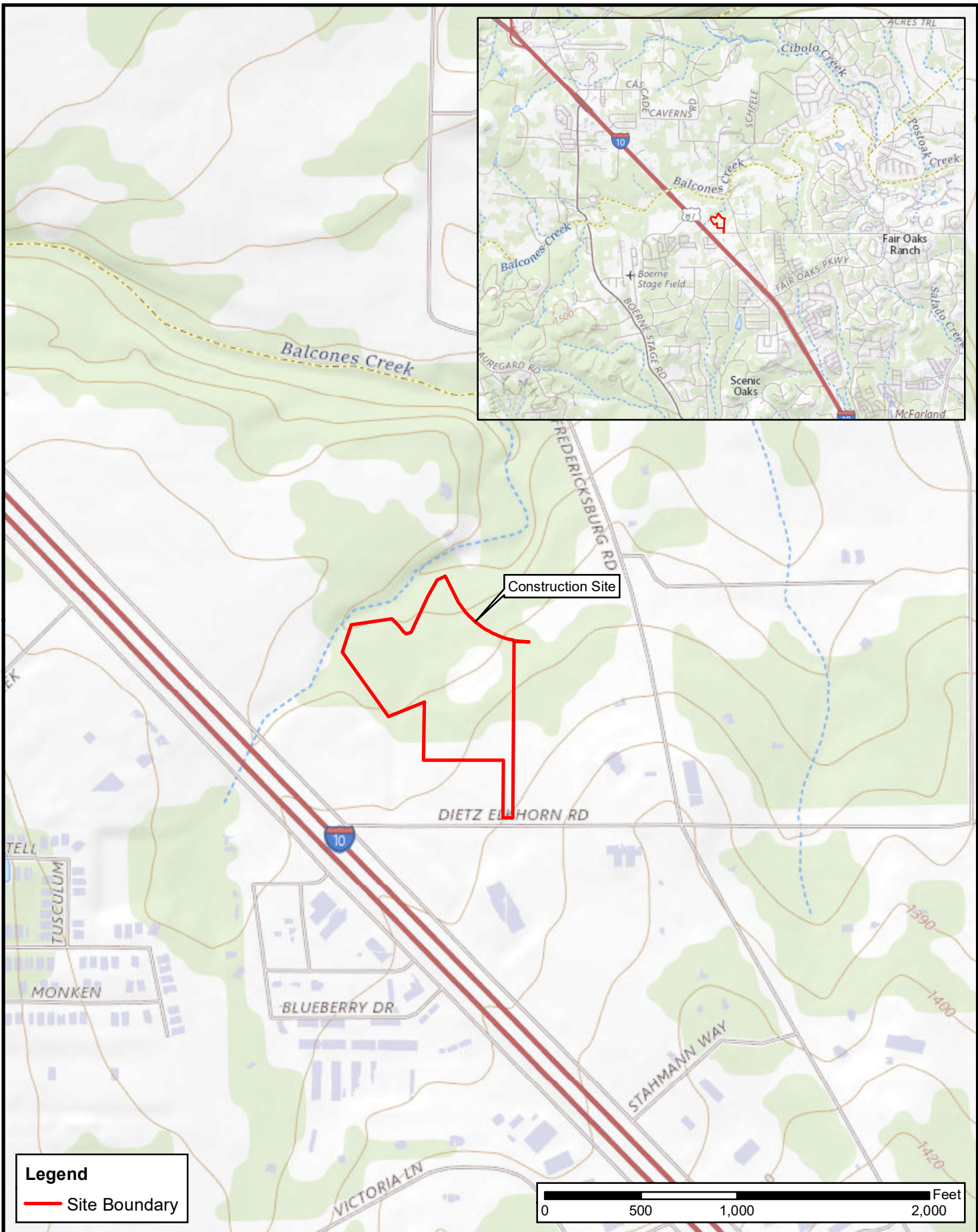

Legend

— Site Boundary

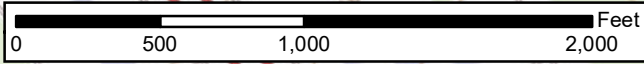

2	DATE:	03/29/2022
	DESIGN:	JWG
	DRAWN:	JWG
	CHECKED:	AJP
	KHA NO.:	064557101

USGS
TOPOGRAPHIC MAP
Attachment B

CZP
Lemon Creek Ranch
Garden Multi-Family
San Antonio ETJ, Bexar County, Texas



Kimley»Horn

This product is for informational purposes and may not have been prepared for or be suitable for legal, engineering, or surveying purposes. It does not represent an on-the-ground survey and represents only the approximate relative location of property boundaries.

ATTACHMENT C – PROJECT NARRATIVE

The subject project is a proposed multi-family residential development on approximately 12.2 acres located in northwest Bexar County, east of IH-10 and just south of the Kendall/Bexar County line. The property is located outside the city limits of San Antonio, Texas, and is entirely over the Edwards Aquifer Contributing Zone. This site is currently undeveloped. An exhibit illustrating the site plan of development is attached. VEP Lemon Creek LP, will be the site operator and will be responsible for compliance with this plan.

The CZP proposes the construction of 349 apartments, civil infrastructure utilities, and associated site improvements for the 349 apartments. Since the impervious cover for the site exceeds 20%, BMP's will be necessary. Two Contech Jellyfish Storm Water Filter Vaults and one Vegetative Filter Strip are proposed to treat storm water runoff from the proposed development of the property. The vegetative filter strip will be engineered and be 15-feet-wide.

ATTACHMENT D – FACTORS AFFECTING SURFACE WATER QUALITY

Surface water quality can be affected by disturbance during construction and by development after construction. Soil disturbance from clearing, grubbing, and cut/fill operations can lead to discharge of sediment unless adequate temporary erosion control measures are in place. For this project, the use of silt fences, inlet protection, and rock berms will prevent sediment from leaving the site. Siltation collected by the control measures will be cleaned from fences, berms, etc. on a routine schedule.

During construction, surface water quality may also be affected by a spill of hydrocarbons or other hazardous substances used in construction. The most likely instances of a spill of hydrocarbons and hazardous substance areas include:

1. Refueling construction equipment
2. Performing operator-level maintenance, including adding petroleum, oils, or lubricants,
3. Unscheduled or emergency repairs, such as hydraulic fluid leaks.

Every effort will be taken to be cautious and prevent spills. In the event of a fuel or hazardous substance spill, the contractor is required to clean up the spill and notify the TCEQ. During business hours, report spills to TCEQ's San Antonio Regional Office at (210) 490-3096. After business hours call 1-800-832-8224.

After construction is complete, impervious cover for the tract of land is the major cause for water quality degradation. Impervious cover includes building, parking, pavement and driveways. Oil and fuel discharges from vehicles is anticipated. The Contech Jellyfish Filters are proposed to treat the first flush of runoff from the site.

ATTACHMENT E – VOLUME AND CHARACTER OF STORMWATER

The construction site is located in the Cibolo Creek watershed. The site generally drains north to Lemon Creek, ultimately out falling to Balcones Creek. The elevation on the construction site ranges from 1373 feet to 1336 feet. Both the existing and proposed contours are provided in the construction plans at the end of this report.

The ±12.2-acre site will include 71% impervious cover. The remaining pervious portions of the site will consist of landscape and natural areas. Runoff from the developed areas will travel as sheet flow and shallow concentrated flow across both pervious and impervious area to the proposed Vegetative Filter strips and storm drainage system which will convey runoff to the Contech Jellyfish Filter Vaults. The locations of the Contech Jellyfish Filter Vaults and Vegetative Filter Strips are shown on the construction plans attached.

The first flush of runoff will contain small amounts of oil, gas, and suspended solids, which will be captured and treated by the Contech Jellyfish Filter Vaults and Vegetative Filter Strips.

ATTACHMENT F – SUITABILITY LETTER FROM AUTHORIZED AGENT

An onsite sewage facility will **not** be used to treat and dispose of wastewater. Not applicable.

ATTACHMENT G- Alternative Secondary Containment Methods

(Not Applicable)

**ATTACHMENT H – ALTERNATIVE SECONDARY CONTAINMENT
STRUCTURE DRAWINGS**

(Not applicable)

ATTACHMENT I – 20% OR LESS IMPERVIOUS COVER WAIVER

(Not applicable)

ATTACHMENT J – BMP’S FOR UPGRADIENT STORM WATER

Runoff generated upgradient of the Lemon Creek Ranch Multifamily Development site will be captured and conveyed by an underground storm water pipe, that being separate from the system that will collect runoff from onsite, and it will be discharged into Lemon Creek. As this offsite stormwater will be routed directly to the creek and not flowing across the proposed site location, there will be no BMP’s for upgradient storm water.

ATTACHMENT K – BMP's for On-Site Storm Water

Two Contech Jellyfish Filter Vaults will be utilized as the permanent treatment systems on this site. Stormwater runoff from drainage area A-1 will be collected by a proposed storm drain system and be routed through the Contech Jellyfish Filter Vaults to provide at least 80% removal of the increase in Total Suspended Solids. Calculations for TSS Removals are provided on the following page. Stormwater runoff from drainage area B-1 will be treated by a Vegetative Filter Strip to provide at least 80% removal of the increase in Total Suspended Solids. The proposed vegetative filter strips will be 15-foot-wide engineered vegetative filter strips. Calculations for TSS Removals are provided on the following page.

Project Name: **Lemon Creek Ranch Apartments**
Date Prepared: **6/23/2023**



1. The Required Load Reduction for the total project:

Calculations from RG-348 Page 3-29 Equation 3.3: $L_M = 27.2(A_N \times P)$
Pages 3-27 to 3-30

$L_{M\text{ TOTAL PROJECT}}$ = Required TSS removal resulting from the proposed development = 80% of increased load
 A_N = Net increase in impervious area for the project
P = Average annual precipitation, inches

Site Data: Determine Required Load Removal Based on the Entire Project

County =	Bexar	
Total project area included in plan * =	12.20	acres
Predevelopment impervious area within the limits of the plan * =	0.00	acres
Total post-development impervious area within the limits of the plan* =	8.44	acres
Total post-development impervious cover fraction * =	0.69	
P =	30	inches
$L_{M\text{ TOTAL PROJECT}}$ =	6885	lbs.

Number of drainage basins / outfalls areas leaving the plan area = **1**

2. Drainage Basin Parameters (This information should be provided for each basin):

Drainage Basin/Outfall Area No. = **1**

Total drainage basin/outfall area =	12.17	acres
Predevelopment impervious area within drainage basin/outfall area =	0.00	acres
Post-development impervious area within drainage basin/outfall area =	8.41	acres
Post-development impervious fraction within drainage basin/outfall area =	0.69	
$L_{M\text{ THIS BASIN}}$ =	6865	lbs.

3. Indicate the proposed BMP Code for this basin.

Proposed BMP = **JF** abbreviation
Removal efficiency = **86** percent

4. Calculate Maximum TSS Load Removed (L_R) for this Drainage Basin by the selected BMP Type.

RG-348 Page 3-33 Equation 3.7:
 $L_R = (\text{BMP efficiency}) \times P \times (A_I \times 34.6 + A_P \times 0.54)$

A_C = Total On-Site drainage area in the BMP catchment area
 A_I = Impervious area proposed in the BMP catchment area
 A_P = Pervious area remaining in the BMP catchment area
 L_R = TSS Load removed from this catchment area by the proposed BMP

A_C =	12.17	acres
A_I =	8.41	acres
A_P =	3.76	acres
L_R =	7562	lbs.

5. Calculate Fraction of Annual Runoff to Treat the drainage basin / outfall area

Desired $L_{M\text{ THIS BASIN}}$ = **6885** lbs.
F = **0.91**

6. Calculate Treated Flow required by the BMP Type for this drainage basin / outfall area.

Offsite area draining to BMP = **0.00** acres
Offsite impervious cover draining to BMP = **0.00** acres

Calculations from RG-348
Pages Section 3.2.22

Rainfall Intensity = **1.15** inches per hour
Effective Area = **7.68** acres
Cartridge Length = **54** inches

Peak Treatment Flow Required = **8.91** cubic feet per second

7. Jellyfish

Designed as Required in RG-348
Section 3.2.22

Flow Through Jellyfish Size

Jellyfish Size for Flow-Based Configuration = **(2)JFPD0812-23-5**
Jellyfish Treatment Flow Rate = **9.10** cfs

CONTECH JELLY FISH STRUCTURE IS SIZED FOR 8.41 AC OF IMPERVIOUS AREA. PER THE TCEQ SITE PLAN, 8.34 AC OF IMPERVIOUS AREA IS TO BE ROUTED THROUGH THE JELLY FISH STRUCTURE

ATTACHMENT L – BMPs For Surface Streams

There is an existing surface stream on site that runs along the western property line and conveys runoff from the south through the property to Lemon Creek to the north. The current stream on site will be conveyed via an underground storm water pipe to fall directly into Lemon Creek. The stormwater runoff from the proposed on-site impervious areas will be treated through the Vegetative Filter Strip and Contech Jellyfish Filter Vaults upstream of the proposed outfall to Lemon Creek. All permanent BMP's have been designed to remove at least 80% of the increase in Total Suspended Solids as per TCEQ requirements. Construction plans, calculations, and specifications are provided at the end of this report. The total suspended solids calculations are included in Attachment K.

ATTACHMENT M - CONSTRUCTION PLANS

Calculations for the load removal requirements for the project and the load removal provided by the permanent BMP's are provided in Attachment K of this report. The calculations have been signed and sealed by a professional engineer licensed in the state of Texas. The load removal requirements are derived from the equations from the technical guidance manual based upon project area and increase in impervious cover. All storm water runoff from impervious areas will be treated by the proposed permanent BMP's to provide the overall required removal of at least 80% of the increase in Total Suspended Solids. Provided within the calculations is a summary of the amount of pollutant load required to be removed from the drainage areas and the amount of removal provided by the permanent BMP's.

Construction plans, details, specifications, calculations and construction notes are provided at the end of this report. The Total Suspended Solids calculations are included in Attachment K.

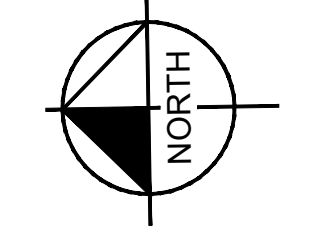

GRAPHIC SCALE IN FEET
0 30 60 120

LEGEND

- PROPERTY BOUNDARY
- DRAINAGE AREA BOUNDARY
- CONTECH JELLYFISH WATER TREATMENT STRUCTURE
- VEGETATIVE FILTER STRIP
- AREAS/STRUCTURES CONVEYING OFFSITE FLOWS THROUGH/AROUND SITE AS BYPASS

PROPERTY AREA = 12.17 AC.
AREA OF SOIL DISTURBANCE = 10.25 AC.
AREA OF UNDISTURBED SOILS = 1.92 AC.

BMP SUMMARY TABLE

DRAINAGE AREA	BMP TYPE	IC BEING TREATED (AC)	REQUIRED TSS REMOVAL (LBS)
B-1	VFS	0.20	N/A
A-1	JF VAULT	8.34	6885

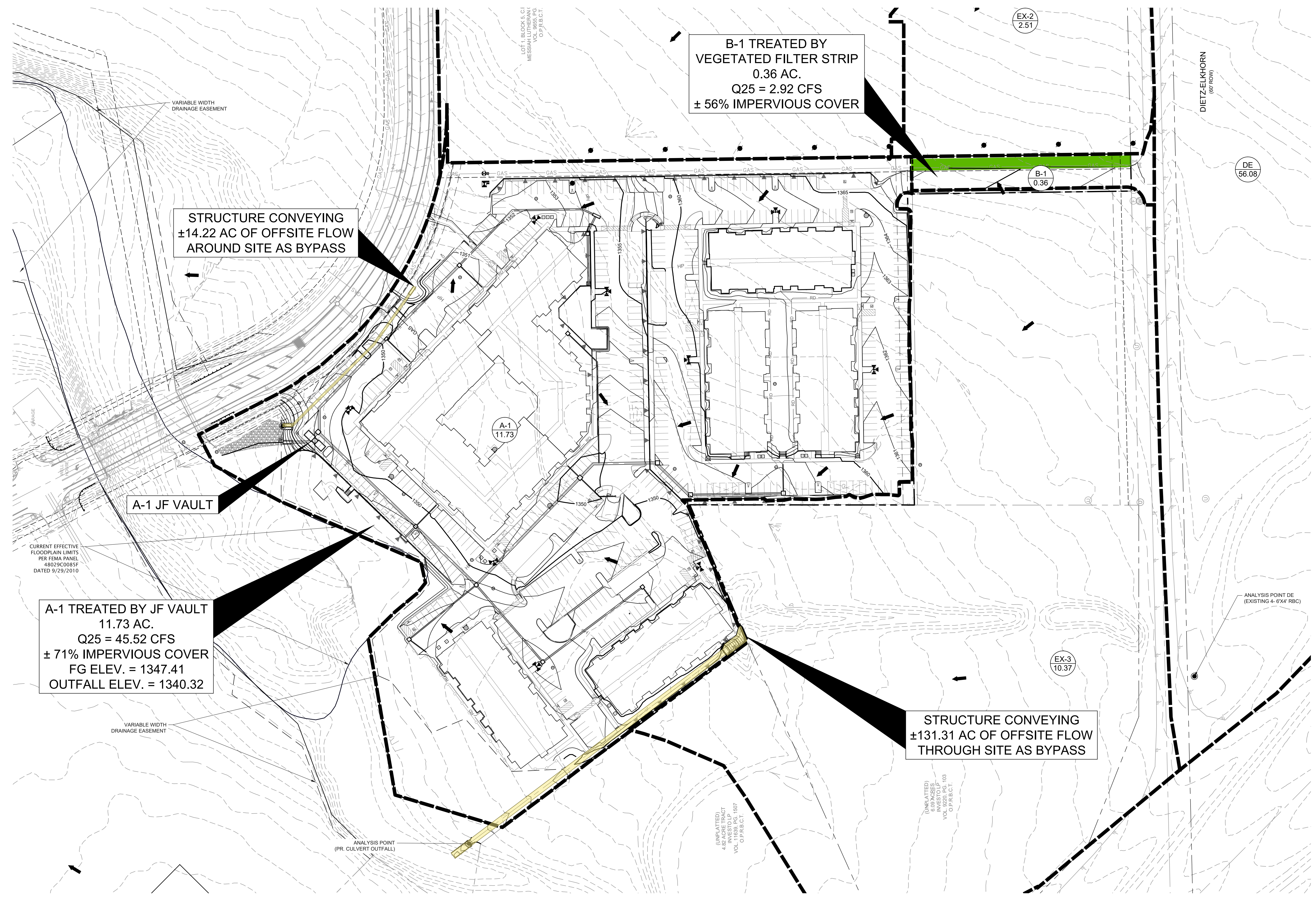

REVISIONS

No.	DATE	BY

Kimley-Horn

©2023 KIMLEY-HORN AND ASSOCIATES, INC. 78216
10100 PHONE 210-341-9166 FAX 210-341-9699
WWW.KIMLEY-HORN.COM TUBE FORM NO. 928

AARON K. PARENICA
LICENSED PROFESSIONAL ENGINEER
99323
8/29/2023

VIA PROJECT 067508807
DATE 8/29/2023
SCALE AS SHOWN
DESIGNED BY AEN
DRAWN BY MAB
CHECKED BY AKP

TCEQ SITE PLAN

LEMON CREEK RANCH MULTI-FAMILY
PREPARED FOR ALLEN HARRISON CO.
SAN ANTONIO E.T.J.



CAUTION!
EXISTING UNDERGROUND UTILITIES IN THE AREA CONTRACTOR IS RESPONSIBLE FOR DETERMINING THE HORIZONTAL AND VERTICAL LOCATION OF ALL UTILITIES PRIOR TO CONSTRUCTION. CONTRACTOR SHALL BE RESPONSIBLE FOR ANY REPAIRS TO EXISTING UTILITIES DUE TO DAMAGE INCURRED DURING CONSTRUCTION. CONTRACTOR SHALL NOTIFY THE ENGINEER OF ANY DISCREPANCIES ON THE PLANS.

Plotted By: Galena, Sebastian August 29, 2023 11:15:45am K:\SNA_CAD\067508807-LOR MF - Allen Harrison CO\CAD\DrawSheets\C-DAMP-OVERALL-067508807.dwg
This document, together with the concepts and designs presented herein, is an instrument of service, is intended only for the specific purpose and client for which it was prepared. Reuse of any part of this document without written authorization and disposition by Kimley-Horn and Associates, Inc. shall be without liability to Kimley-Horn and Associates, Inc.

I:\PSUWOK\TWC\RMF01\QUIKRETE.NET\MERLIN\PROJECT\ACTIVE\743200\743239\743239-10-JELLYFISH\DRAWINGS\PROPOSAL\743239-10-JFPD0812-PRO.DWG 6/23/2023 1:44 PM

JELLYFISH DESIGN NOTES

JELLYFISH TREATMENT CAPACITY IS A FUNCTION OF THE CARTRIDGE LENGTH AND THE NUMBER OF CARTRIDGES. THE STANDARD PEAK DIVERSION STYLE WITH PRECAST TOP SLAB IS SHOWN. ALTERNATE OFFLINE VAULT AND/OR SHALLOW ORIENTATIONS ARE AVAILABLE. PEAK CONVEYANCE CAPACITY TO BE DETERMINED BY ENGINEER OF RECORD

CARTRIDGE SELECTION

CARTRIDGE LENGTH	54"
OUTLET INVERT TO STRUCTURE INVERT (A)	6'-6"
FLOW RATE HIGH-FLO / DRAINDOWN (CFS) (PER CART)	0.178 / 0.089
MAX. TREATMENT (CFS)	5.88
DECK TO INSIDE TOP (MIN) (B)	5.00

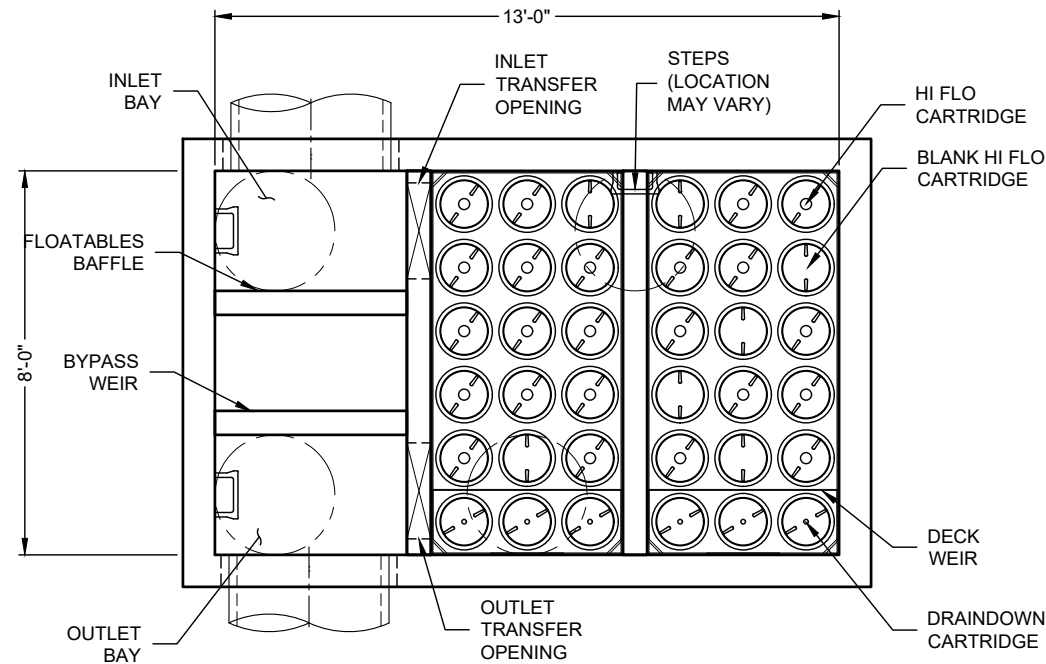

PLAN VIEW
(TOP SLAB NOT SHOWN FOR CLARITY)

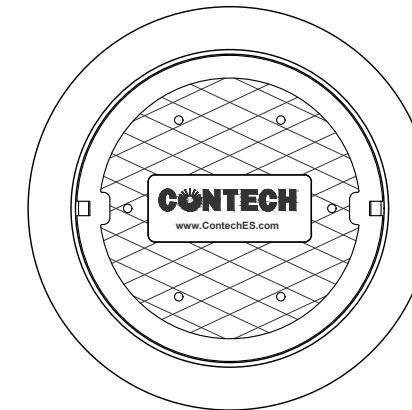

FRAME AND COVER
(DIAMETER VARIES)
N.T.S.

SITE SPECIFIC DATA REQUIREMENTS	
STRUCTURE ID	WQU
WATER QUALITY FLOW RATE (cfs)	8.91
PEAK FLOW RATE (cfs)	51.74
RETURN PERIOD OF PEAK FLOW (yrs)	25
# OF CARTRIDGES REQUIRED (HF / DD)	23 / 5
CARTRIDGE LENGTH	54"
PIPE DATA:	I.E. MAT'L DIA SLOPE % HGL
INLET #1	1340.82' HDPE 36" * * *
INLET #2	* * * * *
OUTLET	1340.32' HDPE 36" * * *
SEE GENERAL NOTES 6-7 FOR INLET AND OUTLET HYDRAULIC AND SIZING REQUIREMENTS.	
RIM ELEVATION	1347.41'
ANTI-FLOTATION BALLAST	WIDTH HEIGHT
	* *
NOTES/SPECIAL REQUIREMENTS:	
* PER ENGINEER OF RECORD	

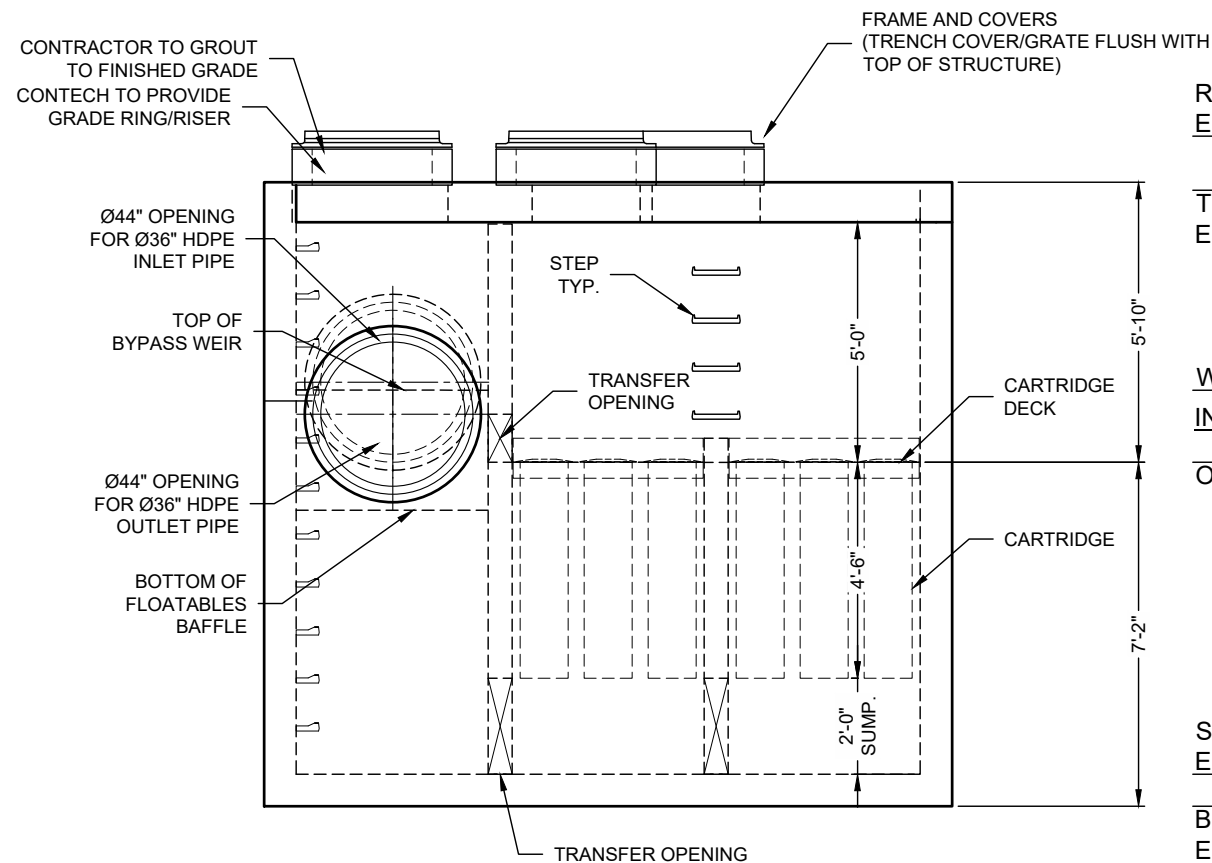

ELEVATION VIEW

RIM
ELEV. = 1347.41'

TOP OF STRUCTURE
ELEV. = 1346.15'

WEIR ELEV. = 1341.82'

INLET INV. ELEV. = 1340.82'

OUTLET INV. ELEV. = 1340.32'

STRUCTURE INV.
ELEV. = 1333.82'

BOTTOM OF STRUCTURE
ELEV. = 1333.15'

GENERAL NOTES:

- CONTECH TO PROVIDE ALL MATERIALS UNLESS NOTED OTHERWISE.
- FOR SITE SPECIFIC DRAWINGS WITH DETAILED STRUCTURE DIMENSIONS AND WEIGHT, PLEASE CONTACT YOUR CONTECH ENGINEERED SOLUTIONS REPRESENTATIVE. www.ContechES.com
- JELLYFISH WATER QUALITY STRUCTURE SHALL BE IN ACCORDANCE WITH ALL DESIGN DATA AND INFORMATION CONTAINED IN THIS DRAWING. CONTRACTOR TO CONFIRM STRUCTURE MEETS REQUIREMENTS OF PROJECT.
- STRUCTURE SHALL MEET AASHTO HS-20 OR PER APPROVING JURISDICTION REQUIREMENTS, WHICHEVER IS MORE STRINGENT, ASSUMING EARTH COVER OF 0' - 10', AND GROUNDWATER ELEVATION AT, OR BELOW, THE OUTLET PIPE INVERT ELEVATION. ENGINEER OF RECORD TO CONFIRM ACTUAL GROUNDWATER ELEVATION. CASTINGS SHALL MEET AASHTO M306 LOAD RATING AND BE CAST WITH THE CONTECH LOGO.
- STRUCTURE SHALL BE PRECAST CONCRETE CONFORMING TO ASTM C-857, ASTM C-918, AND AASHTO LOAD FACTOR DESIGN METHOD.
- OUTLET PIPE INVERT IS EQUAL TO THE CARTRIDGE DECK ELEVATION.
- THE OUTLET PIPE DIAMETER FOR NEW INSTALLATIONS IS RECOMMENDED TO BE ONE PIPE SIZE LARGER THAN THE INLET PIPE AT EQUAL OR GREATER SLOPE.
- NO PRODUCT SUBSTITUTIONS SHALL BE ACCEPTED UNLESS SUBMITTED 10 DAYS PRIOR TO PROJECT BID DATE, OR AS DIRECTED BY THE ENGINEER OF RECORD.

INSTALLATION NOTES

- ANY SUB-BASE, BACKFILL DEPTH, AND/OR ANTI-FLOTATION PROVISIONS ARE SITE-SPECIFIC DESIGN CONSIDERATIONS AND SHALL BE SPECIFIED BY ENGINEER OF RECORD.
- CONTRACTOR TO PROVIDE EQUIPMENT WITH SUFFICIENT LIFTING AND REACH CAPACITY TO LIFT AND SET THE STRUCTURE.
- CONTRACTOR WILL INSTALL AND LEVEL THE STRUCTURE, SEALING THE JOINTS, LINE ENTRY AND EXIT POINTS (NON-SHRINK GROUT WITH APPROVED WATERSTOP OR FLEXIBLE BOOT).
- CARTRIDGE INSTALLATION, BY CONTECH, SHALL OCCUR ONLY AFTER SITE HAS BEEN STABILIZED AND THE JELLYFISH UNIT IS CLEAN AND FREE OF DEBRIS. CONTACT CONTECH TO COORDINATE CARTRIDGE INSTALLATION WITH SITE STABILIZATION.

Jellyfish Filter

THIS PRODUCT MAY BE PROTECTED BY ONE OR MORE OF THE FOLLOWING: U.S. PATENT NO. 8,287,726; 8,221,618; US 8,123,935; OTHER INTERNATIONAL PATENTS PENDING

CONTECH
ENGINEERED SOLUTIONS LLC

www.ContechES.com
9100 Centre Pointe Dr., Suite 400, West Chester, OH 45069
800-338-1122 513-645-7000 513-645-7993 FAX

8' x 12' JELLYFISH - 743239 - 010
LEMON CREEK RANCH APARTMENTS
BOERNE, TX
SITE DESIGNATION: WQU

I:\PSUVOK\TWC\RMF01\QUIKRETE.NET\MERLIN\PROJECT\ACTIVE\743200\743239\743239-10-JELLYFISHDRAWINGS\PROPOSAL\743239-10 JFPD0812-PRO.DWG 6/23/2023 1:44 PM

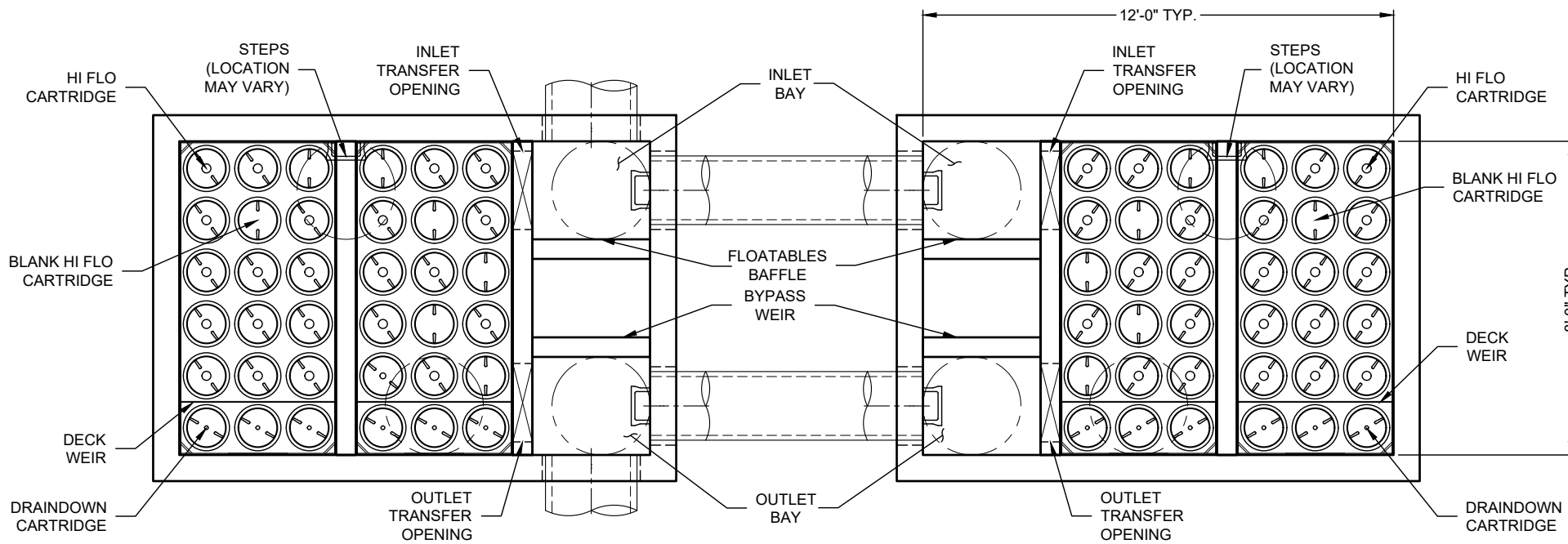

PLAN VIEW
(TOP SLAB NOT SHOWN FOR CLARITY)

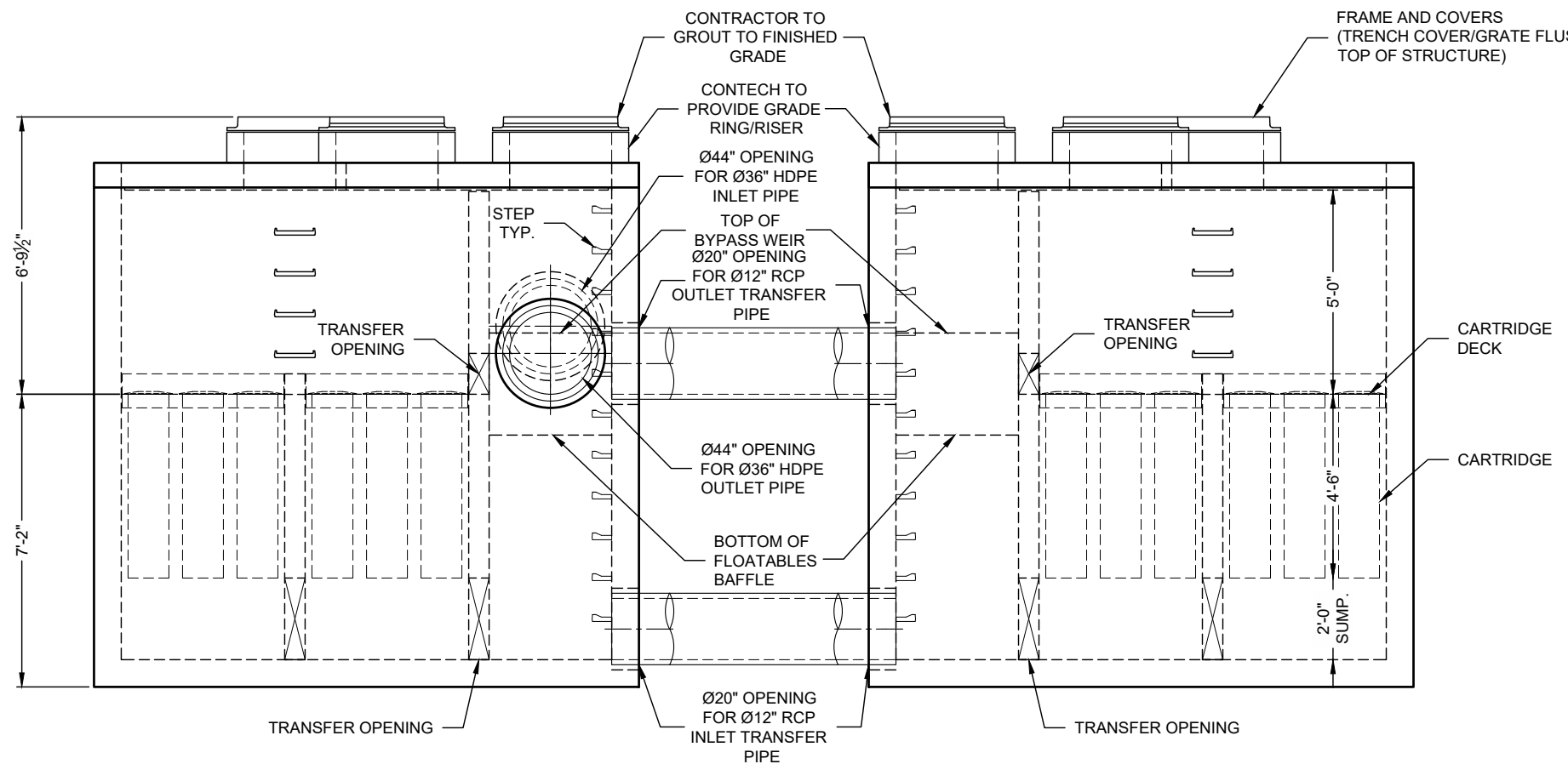

ELEVATION VIEW

- RIM ELEV. = 1347.41'
- TOP OF STRUCTURE ELEV. = 1346.15'
- WEIR ELEV. = 1341.82'
- INLET INV. ELEV. = 1340.82'
- OUTLET INV. ELEV. = 1340.32'
- STRUCTURE INV. ELEV. = 1333.82'
- BOTTOM OF STRUCTURE ELEV. = 1333.15'

Jellyfish Filter

THIS PRODUCT MAY BE PROTECTED BY ONE OR MORE OF THE FOLLOWING: U.S. PATENT NO. 8,287,726; 8,221,618; US 8,123,935; OTHER INTERNATIONAL PATENTS PENDING

(DRAWING NOT TO SCALE)

CONTECH
ENGINEERED SOLUTIONS LLC

www.ContechES.com
9025 Centre Pointe Dr., Suite 400, West Chester, OH 45069
800-338-1122 513-645-7000 513-645-7993 FAX

8' x 12' JELLYFISH - 743239 - 010
LEMON CREEK RANCH APARTMENTS
BOERNE, TX
SITE DESIGNATION: WQU

***Lemon Creek Ranch Garden Multifamily Development
Contributing Zone Plan
Attachment N***

Vegetative Filter Strip Maintenance Guide

The inspection and maintenance of the vegetative filter strips includes the following action items:

1. Cleaning
 - Sediment, debris, trash, and any other items captured by the vegetative filter strip should be removed regularly.
2. Mowing
 - Filter strips should be mowed when the ground is dry to maintain consistent vegetation lengths.
3. Invasive plant species removal
 - Invasive plants and weeds should be removed regularly to prevent overgrowth of the vegetative filter strip and create a sustainable environment for the planted vegetation.
4. Quality checks
 - The filter strips should be checked regularly to ensure there is nothing preventing the vegetation from serving as a permanent BMP throughout the year.

These preventive action items will help maintain the vegetative filter strips to ensure proper treatment of stormwater runoff.

Inspection, Maintenance, Repair and Retrofit Plan

The inspection and maintenance plan outlines the procedures necessary to maintain the performance of the Permanent Best Management Practices for this project. It should be noted that the plan provides guidelines that may have to be adjusted dependent on site-specific and weather-related conditions.

It is the responsibility of the owner of the property to provide the inspections and maintenance as outlined in the plan for the duration of the project. The owner will maintain this responsibility until it is assumed or transferred to another entity in writing. If the property is leased or sold, the responsibility for the maintenance will be required to be transferred through the lease agreement, binding covenants, closing documents, or other binding legal instrument.

Disposal of accumulated silt shall be accomplished following Texas Commission on Environmental Quality guidelines and specifications.

Maintenance records shall be kept on the installation, maintenance, or removal of items necessary for the proper operation of the facilities. All inspections shall be documented.

An amended copy of this document will be provided to the Texas Commission on Environmental Quality within thirty (30) days of any changes in the following information:

Responsible Party: VEP Lemon Creek, LP.
Mailing Address: 1723 N. Loop 1604 E., Suite 240
City, State: San Antonio, Texas 78232
Telephone: 210-824-4242

I, the owner, have read and understand the requirements of the attached Inspection and Maintenance Plan for the proposed Permanent Best Management Practices for my project. I acknowledge that I will maintain responsibility for the implementation and execution of the plan until the responsibility is transferred to or assumed by another party in writing through a binding legal instrument.

Name of Responsible Party (Print): VEP Lemon Creek LP by Charlie Malmbas

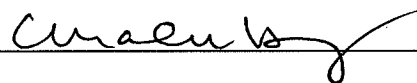
Signature of Responsible Party:  Date: 8/9/2023

Jellyfish[®] Filter Maintenance Guide





JELLYFISH® FILTER INSPECTION & MAINTENANCE GUIDE

Jellyfish units are often just one of many structures in a more comprehensive stormwater drainage and treatment system.

In order for maintenance of the Jellyfish filter to be successful, it is imperative that all other components be properly maintained. The maintenance and repair of upstream facilities should be carried out prior to Jellyfish maintenance activities.

In addition to considering upstream facilities, it is also important to correct any problems identified in the drainage area. Drainage area concerns may include: erosion problems, heavy oil loading, and discharges of inappropriate materials.

TABLE OF CONTENTS

Inspection and Maintenance Overview	3
Inspection Procedure.....	3
Maintenance Procedure.....	4
Cartridge Assembly & Cleaning.....	5
Inspection Process	7

1.0 Inspection and Maintenance Overview

The primary purpose of the Jellyfish® Filter is to capture and remove pollutants from stormwater runoff. As with any filtration system, these pollutants must be removed to maintain the filter's maximum treatment performance. Regular inspection and maintenance are required to insure proper functioning of the system.

Maintenance frequencies and requirements are site specific and vary depending on pollutant loading. Additional maintenance activities may be required in the event of non-storm event runoff, such as base-flow or seasonal flow, an upstream chemical spill or due to excessive sediment loading from site erosion or extreme runoff events. It is a good practice to inspect the system after major storm events.

Inspection activities are typically conducted from surface observations and include:

- Observe if standing water is present
- Observe if there is any physical damage to the deck or cartridge lids
- Observe the amount of debris in the Maintenance Access Wall (MAW) or inlet bay for vault systems

Maintenance activities include:

- Removal of oil, floatable trash and debris
- Removal of collected sediments
- Rinsing and re-installing the filter cartridges
- Replace filter cartridge tentacles, as needed

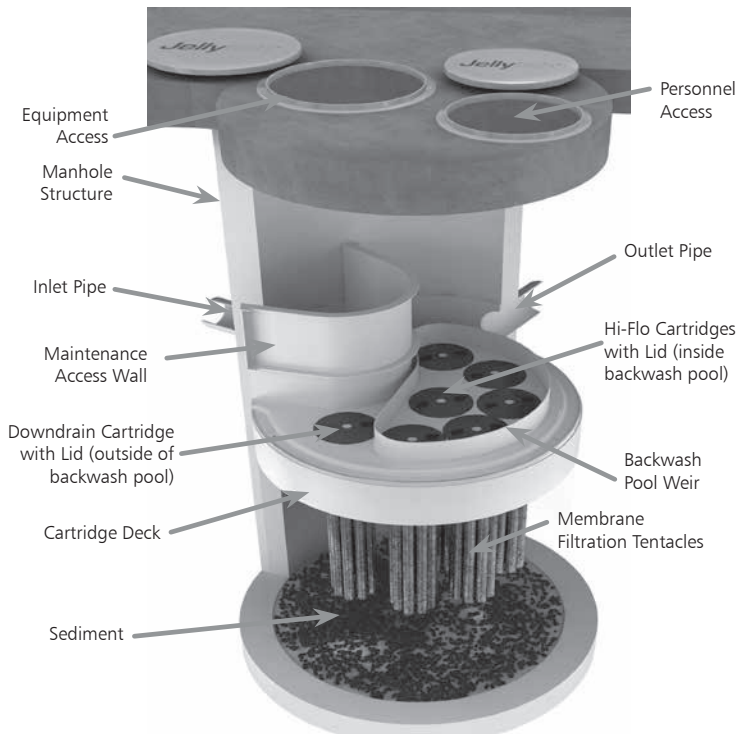

Note: Separator Skirt not shown

2.0 Inspection Timing

Inspection of the Jellyfish Filter is key in determining the maintenance requirements for, and to develop a history of, the site's pollutant loading characteristics. In general, inspections should be performed at the times indicated below; *or per the approved project stormwater quality documents (if applicable), whichever is more frequent.*

1. A minimum of quarterly inspections during the first year of operation to assess the sediment and floatable pollutant accumulation, and to ensure proper functioning of the system.
2. Inspection frequency in subsequent years is based on the inspection and maintenance plan developed in the first year of operation. Minimum frequency should be once per year.
3. Inspection is recommended after each major storm event.
4. Inspection is required immediately after an upstream oil, fuel or other chemical spill.

3.0 Inspection Procedure

The following procedure is recommended when performing inspections:

1. Provide traffic control measures as necessary.
2. Inspect the MAW or inlet bay for floatable pollutants such as trash, debris, and oil sheen.
3. Measure oil and sediment depth in several locations, by lowering a sediment probe until contact is made with the floor of the structure. Record sediment depth, and presences of any oil layers.
4. Inspect cartridge lids. Missing or damaged cartridge lids to be replaced.
5. Inspect the MAW (where appropriate), cartridge deck and receptacles, and backwash pool weir, for damaged or broken components.

3.1 Dry weather inspections

- Inspect the cartridge deck for standing water, and/or sediment on the deck.
- No standing water under normal operating conditions.
- Standing water inside the backwash pool, but not outside the backwash pool indicates, that the filter cartridges need to be rinsed.

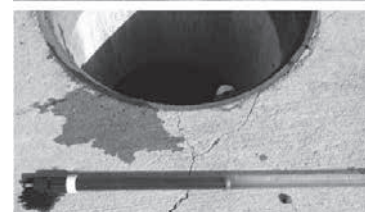

Inspection Utilizing Sediment Probe

- Standing water outside the backwash pool is not anticipated and may indicate a backwater condition caused by high water elevation in the receiving water body, or possibly a blockage in downstream infrastructure.
- Any appreciable sediment ($\geq 1/16''$) accumulated on the deck surface should be removed.

3.2 Wet weather inspections

- Observe the rate and movement of water in the unit. Note the depth of water above deck elevation within the MAW or inlet bay.
- Less than 6 inches, flow should be exiting the cartridge lids of each of the draindown cartridges (i.e. cartridges located outside the backwash pool).
- Greater than 6 inches, flow should be exiting the cartridge lids of each of the draindown cartridges and each of the hi-flo cartridges (i.e. cartridges located inside the backwash pool), and water should be overflowing the backwash pool weir.
- 18 inches or greater and relatively little flow is exiting the cartridge lids and outlet pipe, this condition indicates that the filter cartridges need to be rinsed.

4.0 Maintenance Requirements

Required maintenance for the Jellyfish Filter is based upon results of the most recent inspection, historical maintenance records, or the site specific water quality management plan; whichever is more frequent. In general, maintenance requires some combination of the following:

1. Sediment removal for depths reaching 12 inches or greater, or within 3 years of the most recent sediment cleaning, whichever occurs sooner.
2. Floatable trash, debris, and oil removal.
3. Deck cleaned and free from sediment.
4. Filter cartridges rinsed and re-installed as required by the most recent inspection results, or within 12 months of the most recent filter rinsing, whichever occurs sooner.
5. Replace tentacles if rinsing does not restore adequate hydraulic capacity, remove accumulated sediment, or if damaged or missing. It is recommended that tentacles should remain in service no longer than 5 years before replacement.
6. Damaged or missing cartridge deck components must be repaired or replaced as indicated by results of the most recent inspection.
7. The unit must be cleaned out and filter cartridges inspected immediately after an upstream oil, fuel, or chemical spill. Filter cartridge tentacles should be replaced if damaged or compromised by the spill.

5.0 Maintenance Procedure

The following procedures are recommended when maintaining the Jellyfish Filter:

1. Provide traffic control measures as necessary.
2. Open all covers and hatches. Use ventilation equipment as required, according to confined space entry procedures.
Caution: Dropping objects onto the cartridge deck may cause damage.

3. Perform Inspection Procedure prior to maintenance activity.
4. To access the cartridge deck for filter cartridge service, descend into the structure and step directly onto the deck. Caution: Do not step onto the maintenance access wall (MAW) or backwash pool weir, as damage may result. Note that the cartridge deck may be slippery.
5. Maximum weight of maintenance crew and equipment on the cartridge deck not to exceed 450 lbs.

5.1 Filter Cartridge Removal

1. Remove a cartridge lid.
2. Remove cartridges from the deck using the lifting loops in the cartridge head plate. Rope or a lifting device (available from Contech) should be used. **Caution: Should a snag occur, do not force the cartridge upward as damage to the tentacles may result. Wet cartridges typically weigh between 100 and 125 lbs.**
3. Replace and secure the cartridge lid on the exposed empty receptacle as a safety precaution. Contech does not recommend exposing more than one empty cartridge receptacle at a time.

5.2 Filter Cartridge Rinsing

1. Remove all 11 tentacles from the cartridge head plate. Take care not to lose or damage the O-ring seal as well as the plastic threaded nut and connector.



Cartridge Removal & Lifting Device



2. Position tentacles in a container (or over the MAW), with the threaded connector (open end) facing down, so rinse water is flushed through the membrane and captured in the container.
3. Using the Jellyfish rinse tool (available from Contech) or a low-pressure garden hose sprayer, direct water spray onto the tentacle membrane, sweeping from top to bottom along the length of the tentacle. Rinse until all sediment is removed from the membrane. **Caution: Do not use a high pressure sprayer or focused stream of water on the membrane. Excessive water pressure may damage the membrane.**

4. Collected rinse water is typically removed by vacuum hose.
5. Reassemble cartridges as detailed later in this document. Reuse O-rings and nuts, ensuring proper placement on each tentacle.

5.3 Sediment and Floatables Extraction

1. Perform vacuum cleaning of the Jellyfish Filter only after filter cartridges have been removed from the system. Access the lower chamber for vacuum cleaning only through the maintenance access wall (MAW) opening. Be careful not to damage the flexible plastic separator skirt that is attached to the underside of the deck on manhole systems. Do not lower the vacuum wand through a cartridge receptacle, as damage to the receptacle will result.
2. Vacuum floatable trash, debris, and oil, from the MAW opening or inlet bay. Alternatively, floatable solids may be removed by a net or skimmer.



Vacuuming Sump Through MAW

3. Pressure wash cartridge deck and receptacles to remove all sediment and debris. Sediment should be rinsed into the sump area. Take care not to flush rinse water into the outlet pipe.
4. Remove water from the sump area. Vacuum or pump equipment should only be introduced through the MAW or inlet bay.
5. Remove the sediment from the bottom of the unit through the MAW or inlet bay opening.



Vacuuming Sump Through MAW

6. For larger diameter Jellyfish Filter manholes (≥ 8 -ft) and some vaults complete sediment removal may be facilitated by removing a cartridge lid from an empty receptacle and inserting a jetting wand (not a vacuum wand) through the receptacle. Use the sprayer to rinse loosened sediment toward the vacuum hose in the MAW opening, being careful not to damage the receptacle.

5.4 Filter Cartridge Reinstallation and Replacement

1. Cartridges should be installed after the deck has been cleaned. It is important that the receptacle surfaces be free from grit and debris.
2. Remove cartridge lid from deck and carefully lower the filter cartridge into the receptacle until head plate gasket is seated squarely in receptacle. **Caution: Do not force the cartridge downward; damage may occur.**
3. Replace the cartridge lid and check to see that both male threads are properly seated before rotating approximately 1/3 of a full rotation until firmly seated. Use of an approved rim gasket lubricant may facilitate installation. See next page for additional details.
4. If rinsing is ineffective in removing sediment from the tentacles, or if tentacles are damaged, provisions must be made to replace the spent or damaged tentacles with new tentacles. Contact Contech to order replacement tentacles.

5.5 Chemical Spills

Caution: If a chemical spill has been captured, do not attempt maintenance. Immediately contact the local hazard response agency and contact Contech.

5.6 Material Disposal

The accumulated sediment found in stormwater treatment and conveyance systems must be handled and disposed of in accordance with regulatory protocols. It is possible for sediments to contain measurable concentrations of heavy metals and organic chemicals (such as pesticides and petroleum products). Areas with the greatest potential for high pollutant loading include industrial areas and heavily traveled roads. Sediments and water must be disposed of in accordance with all applicable waste disposal regulations. When scheduling maintenance, consideration must be made for the disposal of solid and liquid wastes. This typically requires coordination with a local landfill for solid waste disposal. For liquid waste disposal a number of options are available including a municipal vacuum truck decant facility, local waste water treatment plant or on-site treatment and discharge.

Jellyfish Filter Components & Filter Cartridge Assembly and Installation

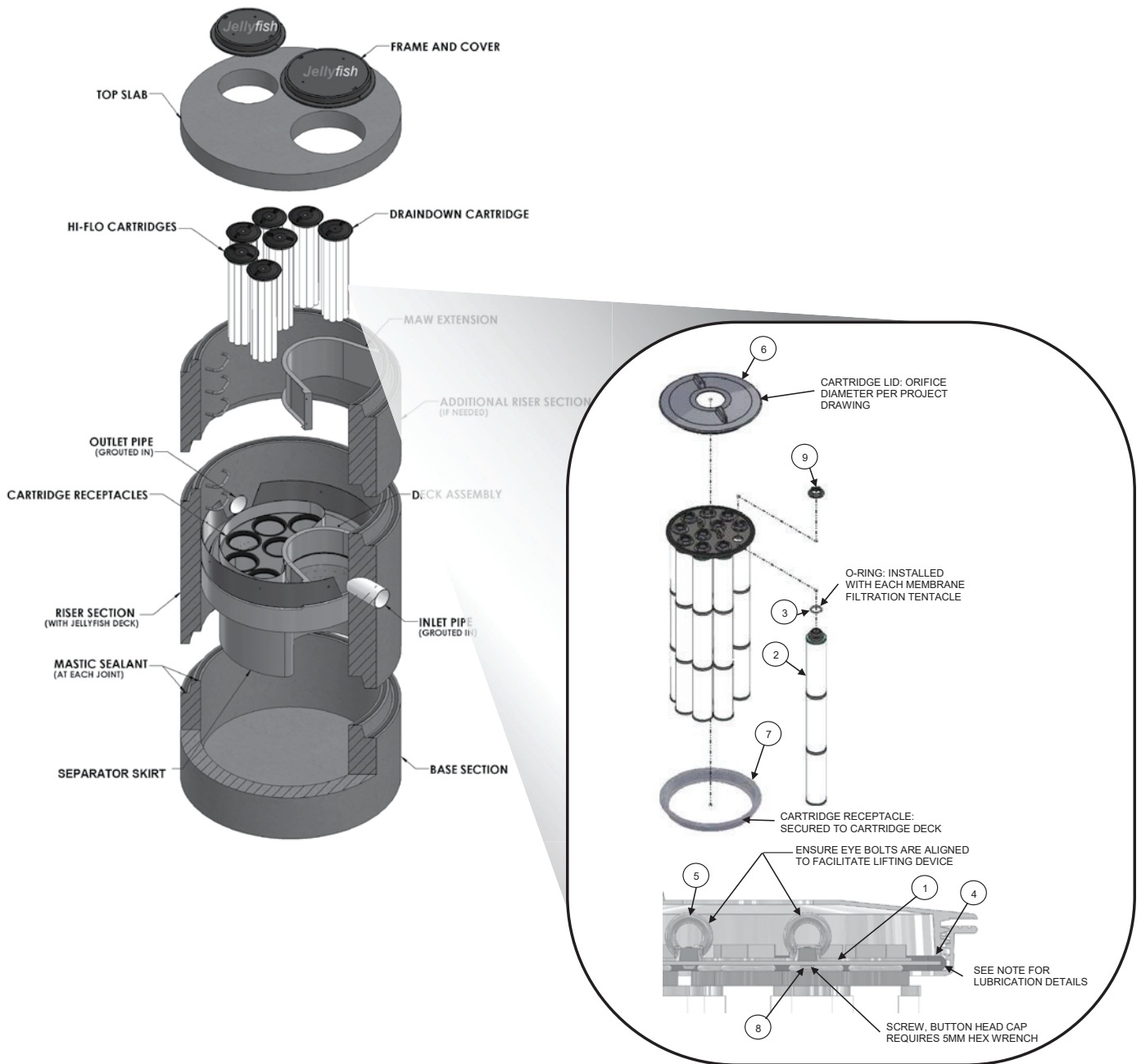

TABLE 1: BOM

ITEM NO.	DESCRIPTION
1	JF HEAD PLATE
2	JF TENTACLE
3	JF O-RING
4	JF HEAD PLATE GASKET
5	JF CARTRIDGE EYELET
6	JF 14IN COVER
7	JF RECEPTACLE
8	BUTTON HEAD CAP SCREW M6X14MM SS
9	JF CARTRIDGE NUT

TABLE 2: APPROVED GASKET LUBRICANTS

PART NO.	MFR	DESCRIPTION
78713	LA-CO	LUBRI-JOINT
40501	HERCULES	DUCK BUTTER
30600	OATEY	PIPE LUBRICANT
PSLUBXL1Q	PROSELECT	PIPE JOINT LUBRICANT

NOTES:

Head Plate Gasket Installation:

Install Head Plate Gasket (Item 4) onto the Head Plate (Item 1) and liberally apply a lubricant from Table 2: Approved Gasket Lubricants onto the gasket where it contacts the Receptacle (Item 7) and Cartridge Lid (Item 6). Follow Lubricant manufacturer's instructions.

Lid Assembly:

Rotate Cartridge Lid counter-clockwise until both male threads drop down and properly seat. Then rotate Cartridge Lid clockwise approximately one-third of a full rotation until Cartridge Lid is firmly secured, creating a watertight seal.

Jellyfish Filter Inspection and Maintenance Log

Owner:		Jellyfish Model No:	
Location:		GPS Coordinates:	
Land Use:	Commercial:	Industrial:	Service Station:
	Roadway/Highway:	Airport:	Residential:

Date/Time:						
Inspector:						
Maintenance Contractor:						
Visible Oil Present: (Y/N)						
Oil Quantity Removed:						
Floatable Debris Present: (Y/N)						
Floatable Debris Removed: (Y/N)						
Water Depth in Backwash Pool						
Draindown Cartridges externally rinsed and recommissioned: (Y/N)						
New tentacles put on Draindown Cartridges: (Y/N)						
Hi-Flo Cartridges externally rinsed and recommissioned: (Y/N)						
New tentacles put on Hi-Flo Cartridges: (Y/N)						
Sediment Depth Measured: (Y/N)						
Sediment Depth (inches or mm):						
Sediment Removed: (Y/N)						
Cartridge Lids intact: (Y/N)						
Observed Damage:						
Comments:						



Support

- Drawings and specifications are available at www.conteches.com/jellyfish.
- Site-specific design support is available from Contech Engineered Solutions.
- Find a Certified Maintenance Provider at www.conteches.com/ccmp

Jellyfish[®]

CONTECH[®]
ENGINEERED SOLUTIONS

800.338.1122

www.ContechES.com

© 2021 Contech Engineered Solutions LLC, a QUIKRETE Company

Contech Engineered Solutions LLC provides site solutions for the civil engineering industry. Contech's portfolio includes bridges, drainage, sanitary sewer, stormwater, wastewater treatment and earth stabilization products. For information on other Contech segment offerings, visit ContechES.com or call 800.338.1122

NOTHING IN THIS CATALOG SHOULD BE CONSTRUED AS A WARRANTY. APPLICATIONS SUGGESTED HEREIN ARE DESCRIBED ONLY TO HELP READERS MAKE THEIR OWN EVALUATIONS AND DECISIONS, AND ARE NEITHER GUARANTEES NOR WARRANTIES OF SUITABILITY FOR ANY APPLICATION. CONTECH MAKES NO WARRANTY WHATSOEVER, EXPRESS OR IMPLIED, RELATED TO THE APPLICATIONS, MATERIALS, COATINGS, OR PRODUCTS DISCUSSED HEREIN. ALL IMPLIED WARRANTIES OF MERCHANTABILITY AND ALL IMPLIED WARRANTIES OF FITNESS FOR ANY PARTICULAR PURPOSE ARE DISCLAIMED BY CONTECH. SEE CONTECH'S CONDITIONS OF SALE (AVAILABLE AT WWW.CONTECHES.COM/COS) FOR MORE INFORMATION.

ATTACHMENT O - PILOT-SCALE FIELD TESTING PLAN

The TCEQ Technical Guidance Manual (TGM) was used to design permanent BMPs and measures for this site; therefore pilot-scale field testing is not required.

**ATTACHMENT P – MEASURES FOR MINIMIZING STREAM
CONTAMINATION**

Any points where discharge from the site is concentrated and excessive velocities exist will include appropriately sized energy dissipaters to reduce velocities to non-erosive levels.



Notice of Intent (NOI) for an Authorization for Stormwater Discharges Associated with Construction Activity under TPDES General Permit TXR150000

IMPORTANT INFORMATION

Please read and use the General Information and Instructions prior to filling out each question in the NOI form.

Use the NOI Checklist to ensure all required information is completed correctly.
Incomplete applications delay approval or result in automatic denial.

Once processed your permit authorization can be viewed by entering the following link into your internet browser: http://www2.tceq.texas.gov/wq_dpa/index.cfm or you can contact TCEQ Stormwater Processing Center at 512-239-3700.

ePERMITS

Effective September 1, 2018, this paper form must be submitted to TCEQ with a completed electronic reporting waiver form (TCEQ-20754).

To submit an NOI electronically, enter the following web address into your internet browser and follow the instructions: <https://www3.tceq.texas.gov/steers/index.cfm>

APPLICATION FEE AND PAYMENT

The application fee for submitting a paper NOI is \$325. The application fee for electronic submittal of a NOI through the TCEQ ePermits system (STEERS) is \$225.

Payment of the application fee can be submitted by mail or through the TCEQ ePay system. The payment and the NOI must be mailed to separate addresses. To access the TCEQ ePay system enter the following web address into your internet browser:
<http://www.tceq.texas.gov/epay>.

Provide your payment information for verification of payment:

- If payment was mailed to TCEQ, provide the following:
 - Check/Money Order Number: [REDACTED]
 - Name printed on Check: [REDACTED]
- If payment was made via ePay, provide the following:
 - Voucher Number: [REDACTED]
 - A copy of the payment voucher is attached to this paper NOI form.

RENEWAL (This portion of the NOI is not applicable after June 3, 2018)

Is this NOI for a renewal of an existing authorization? Yes No

If Yes, provide the authorization number here: TXR15 [redacted]

NOTE: If an authorization number is not provided, a new number will be assigned.

SECTION 1. OPERATOR (APPLICANT)

a) If the applicant is currently a customer with TCEQ, what is the Customer Number (CN) issued to this entity? CN [redacted]

(Refer to Section 1.a) of the Instructions)

b) What is the Legal Name of the entity (applicant) applying for this permit? (The legal name must be spelled exactly as filed with the Texas Secretary of State, County, or in the legal document forming the entity.)

Lemon Creek Ranch Garden Multifamily

c) What is the contact information for the Operator (Responsible Authority)?

Prefix (Mr. Ms. Miss): [redacted]

First and Last Name: Charlie Malmberg Suffix: [redacted]

Title: Signee Credentials:

Phone Number: (210) 824-4242 Fax Number: [redacted]

E-mail: charlie@valcorcre.com

Mailing Address: 1723 N. Loop 1604 E, Suite 240

City, State, and Zip Code: San Antonio, Texas 78232

Mailing Information if outside USA:

Territory: [redacted]

Country Code: [redacted] Postal Code: [redacted]

d) Indicate the type of customer:

- | | |
|---|---|
| <input type="checkbox"/> Individual | <input type="checkbox"/> Federal Government |
| <input type="checkbox"/> Limited Partnership | <input type="checkbox"/> County Government |
| <input type="checkbox"/> General Partnership | <input type="checkbox"/> State Government |
| <input type="checkbox"/> Trust | <input type="checkbox"/> City Government |
| <input type="checkbox"/> Sole Proprietorship (D.B.A.) | <input type="checkbox"/> Other Government |
| <input type="checkbox"/> Corporation | <input checked="" type="checkbox"/> Other: <u>Limited Liability Company (LLC)</u> |
| <input type="checkbox"/> Estate | |

e) Is the applicant an independent operator? Yes No

- b) Name of project or site (the name known by the community where it's located): Lemon Creek Ranch Multifamily
- c) In your own words, briefly describe the type of construction occurring at the regulated site (residential, industrial, commercial, or other): Multi-family Residential
- d) County or Counties (if located in more than one): Bexar County
- e) Latitude: N29.732889 Longitude: W90.677125
- f) Site Address/Location

If the site has a physical address such as 12100 Park 35 Circle, Austin, TX 78753, complete *Section A*.

If the site does not have a physical address, provide a location description in *Section B*. Example: located on the north side of FM 123, 2 miles west of the intersection of FM 123 and Highway 1.

Section A:

Street Number and Name: 9405 Dietz Elkhorn Road

City, State, and Zip Code: San Antonio, ETJ, 78006

Section B:

Location Description: Located generally and approximately .15 miles east of IH-10 and north of Dietz Elkhorn Rd.

City (or city nearest to) where the site is located: San Antonio ETJ

Zip Code where the site is located: 78006

SECTION 4. GENERAL CHARACTERISTICS

- a) Is the project or site located on Indian Country Lands?
 - Yes, do not submit this form. You must obtain authorization through EPA Region 6.
 - No
- b) Is your construction activity associated with a facility that, when completed, would be associated with the exploration, development, or production of oil or gas or geothermal resources?
 - Yes. Note: The construction stormwater runoff may be under jurisdiction of the Railroad Commission of Texas and may need to obtain authorization through EPA Region 6.
 - No
- c) What is the Primary Standard Industrial Classification (SIC) Code that best describes the construction activity being conducted at the site? 1522
- d) What is the Secondary SIC Code(s), if applicable?
- e) What is the total number of acres to be disturbed? 12.2

- f) Is the project part of a larger common plan of development or sale?
- Yes
- No. The total number of acres disturbed, provided in e) above, must be 5 or more. If the total number of acres disturbed is less than 5, do not submit this form. See the requirements in the general permit for small construction sites.
- g) What is the estimated start date of the project? [REDACTED]
- h) What is the estimated end date of the project? [REDACTED]
- i) Will concrete truck washout be performed at the site? Yes No
- j) What is the name of the first water body(ies) to receive the stormwater runoff or potential runoff from the site? Lemon Creek
- k) What is the segment number(s) of the classified water body(ies) that the discharge will eventually reach? 1908
- l) Is the discharge into a Municipal Separate Storm Sewer System (MS4)?
- Yes No

If Yes, provide the name of the MS4 operator: [REDACTED]

Note: The general permit requires you to send a copy of this NOI form to the MS4 operator.

- m) Is the discharge or potential discharge from the site within the Recharge Zone, Contributing Zone, or Contributing Zone within the Transition Zone of the Edwards Aquifer, as defined in 30 TAC Chapter 213?
- Yes, complete the certification below.
- No, go to Section 5

I certify that the copy of the TCEQ-approved Plan required by the Edwards Aquifer Rule (30 TAC Chapter 213) that is included or referenced in the Stormwater Pollution Prevention Plan will be implemented. Yes

SECTION 5. NOI CERTIFICATION

- a) I certify that I have obtained a copy and understand the terms and conditions of the Construction General Permit (TXR150000). Yes
- b) I certify that the full legal name of the entity applying for this permit has been provided and is legally authorized to do business in Texas. Yes
- c) I understand that a Notice of Termination (NOT) must be submitted when this authorization is no longer needed. Yes
- d) I certify that a Stormwater Pollution Prevention Plan has been developed, will be implemented prior to construction and to the best of my knowledge and belief is compliant with any applicable local sediment and erosion control plans, as required in the Construction General Permit (TXR150000). Yes

Note: For multiple operators who prepare a shared SWP3, the confirmation of an operator may be limited to its obligations under the SWP3, provided all obligations are confirmed by at least one operator.

SECTION 6. APPLICANT CERTIFICATION SIGNATURE

Operator Signatory Name: Aaron Parenica

Operator Signatory Title: Project Manager

I certify under penalty of law that this document and all attachments were prepared under my direction or supervision in accordance with a system designed to assure that qualified personnel properly gather and evaluate the information submitted. Based on my inquiry of the person or persons who manage the system, or those persons directly responsible for gathering the information, the information submitted is, to the best of my knowledge and belief, true, accurate, and complete. I am aware there are significant penalties for submitting false information, including the possibility of fine and imprisonment for knowing violations.

I further certify that I am authorized under 30 Texas Administrative Code §305.44 to sign and submit this document, and can provide documentation in proof of such authorization upon request.

Signature (use blue ink):  Date: 7/13/2023

NOTICE OF INTENT CHECKLIST (TXR150000)

Did you complete everything? Use this checklist to be sure!

Are you ready to mail your form to TCEQ? Go to the General Information Section of the Instructions for mailing addresses.

Confirm each item (or applicable item) in this form is complete. This checklist is for use by the applicant to ensure a complete application is being submitted. **Missing information may result in denial of coverage under the general permit.** (See NOI process description in the General Information and Instructions.)

APPLICATION FEE

If paying by check:

- Check was mailed **separately** to the TCEQs Cashier's Office. (See Instructions for Cashier's address and Application address.)
- Check number and name on check is provided in this application.

If using ePay:

- The voucher number is provided in this application and a copy of the voucher is attached.

RENEWAL

- If this application is for renewal of an existing authorization, the authorization number is provided.

OPERATOR INFORMATION

- Customer Number (CN) issued by TCEQ Central Registry
- Legal name as filed to do business in Texas. (Call TX SOS 512-463-5555 to verify.)
- Name and title of responsible authority signing the application.
- Phone number and e-mail address
- Mailing address is complete & verifiable with USPS. www.usps.com
- Type of operator (entity type). Is applicant an independent operator?
- Number of employees.
- For corporations or limited partnerships - Tax ID and SOS filing numbers.
- Application contact and address is complete & verifiable with USPS. <http://www.usps.com>

REGULATED ENTITY (RE) INFORMATION ON PROJECT OR SITE

- Regulated Entity Number (RN) (if site is already regulated by TCEQ)
- Site/project name and construction activity description
- County
- Latitude and longitude <http://www.tceq.texas.gov/gis/sqmaview.html>

Site Address/Location. Do not use a rural route or post office box.

GENERAL CHARACTERISTICS

- Indian Country Lands -the facility is not on Indian Country Lands.
- Construction activity related to facility associated to oil, gas, or geothermal resources
- Primary SIC Code that best describes the construction activity being conducted at the site. www.osha.gov/oshstats/sicser.html
- Estimated starting and ending dates of the project.
- Confirmation of concrete truck washout.
- Acres disturbed is provided and qualifies for coverage through a NOI.
- Common plan of development or sale.
- Receiving water body or water bodies.
- Segment number or numbers.
- MS4 operator.
- Edwards Aquifer rule.

CERTIFICATION

- Certification statements have been checked indicating Yes.
- Signature meets 30 Texas Administrative Code (TAC) §305.44 and is original.

Instructions for Notice of Intent (NOI) for Stormwater Discharges Associated with Construction Activity under TPDES General Permit (TXR150000)

GENERAL INFORMATION

Where to Send the Notice of Intent (NOI):

By Regular Mail:

TCEQ

Stormwater Processing Center (MC228)

P.O. Box 13087

Austin, Texas 78711-3087

By Overnight or Express Mail:

TCEQ

Stormwater Processing Center (MC228)

12100 Park 35 Circle

Austin, TX

Application Fee:

The application fee of \$325 is required to be paid at the time the NOI is submitted. Failure to submit payment at the time the application is filed will cause delays in acknowledgment or denial of coverage under the general permit. Payment of the fee may be made by check or money order, payable to TCEQ, or through EPAY (electronic payment through the web).

Mailed Payments:

Use the attached General Permit Payment Submittal Form. The application fee is submitted to a different address than the NOI. Read the General Permit Payment Submittal Form for further instructions, including the address to send the payment.

ePAY Electronic Payment: <http://www.tceq.texas.gov/epay>

When making the payment you must select Water Quality, and then select the fee category "General Permit Construction Storm Water Discharge NOI Application". You must include a copy of the payment voucher with your NOI. Your NOI will not be considered complete without the payment voucher.

TCEQ Contact List:

Application - status and form questions:

512-239-3700, swpermit@tceq.texas.gov

Technical questions:

512-239-4671, swgp@tceq.texas.gov

Environmental Law Division:

512-239-0600

Records Management - obtain copies of forms:

512-239-0900

Reports from databases (as available):

512-239-DATA (3282)

Cashier's office:

512-239-0357 or 512-239-0187

Notice of Intent Process:

When your NOI is received by the program, the form will be processed as follows:

- **Administrative Review:** Each item on the form will be reviewed for a complete response. In addition, the operator's legal name must be verified with Texas Secretary of State as valid and active (if applicable). The address(es) on the form must be verified with the US Postal service as receiving regular mail delivery. Do not give an overnight/express mailing address.

- **Notice of Deficiency:** If an item is incomplete or not verifiable as indicated above, a notice of deficiency (NOD) will be mailed to the operator. The operator will have 30 days to respond to the NOD. The response will be reviewed for completeness.
- **Acknowledgment of Coverage:** An Acknowledgment Certificate will be mailed to the operator. This certificate acknowledges coverage under the general permit.

or

Denial of Coverage: If the operator fails to respond to the NOD or the response is inadequate, coverage under the general permit may be denied. If coverage is denied, the operator will be notified.

General Permit (Your Permit)

For NOIs submitted **electronically** through ePermits, provisional coverage under the general permit begins immediately following confirmation of receipt of the NOI form by the TCEQ.

For **paper** NOIs, provisional coverage under the general permit begins **7 days after a completed NOI is postmarked for delivery** to the TCEQ.

You should have a copy of your general permit when submitting your application. You may view and print your permit for which you are seeking coverage, on the TCEQ web site <http://www.tceq.texas.gov>. Search using keyword TXR150000.

Change in Operator

An authorization under the general permit is not transferable. If the operator of the regulated project or site changes, the present permittee must submit a Notice of Termination and the new operator must submit a Notice of Intent. The NOT and NOI must be submitted no later than 10 days prior to the change in Operator status.

TCEQ Central Registry Core Data Form

The Core Data Form has been incorporated into this form. Do not send a Core Data Form to TCEQ. After final acknowledgment of coverage under the general permit, the program will assign a Customer Number and Regulated Entity Number, if one has not already been assigned to this customer or site.

For existing customers and sites, you can find the Customer Number and Regulated Entity Number by entering the following web address into your internet browser: <http://www15.tceq.texas.gov/crpub/> or you can contact the TCEQ Stormwater Processing Center at 512-239-3700 for assistance. On the website, you can search by your permit number, the Regulated Entity (RN) number, or the Customer Number (CN). If you do not know these numbers, you can select “Advanced Search” to search by permittee name, site address, etc.

The Customer (Permittee) is responsible for providing consistent information to the TCEQ, and for updating all CN and RN data for all authorizations as changes occur. For this permit, a Notice of Change form must be submitted to the program area.

INSTRUCTIONS FOR FILLING OUT THE NOI FORM

Renewal of General Permit. Dischargers holding active authorizations under the expired General Permit are required to submit a NOI to continue coverage. The existing permit number is required. If the permit number is not provided or has been terminated, expired, or denied, a new permit number will be issued.

Section 1. OPERATOR (APPLICANT)

a) Customer Number (CN)

TCEQ's Central Registry will assign each customer a number that begins with CN, followed by nine digits. **This is not a permit number, registration number, or license number.**

If the applicant is an existing TCEQ customer, the Customer Number is available at the following website: <http://www15.tceq.texas.gov/crpub/>. If the applicant is not an existing TCEQ customer, leave the space for CN blank.

b) Legal Name of Applicant

Provide the current legal name of the applicant. The name must be provided exactly as filed with the Texas Secretary of State (SOS), or on other legal documents forming the entity, as filed in the county. You may contact the SOS at 512-463-5555, for more information related to filing in Texas. If filed in the county, provide a copy of the legal documents showing the legal name.

c) Contact Information for the Applicant (Responsible Authority)

Provide information for the person signing the application in the Certification section. This person is also referred to as the Responsible Authority.

Provide a complete mailing address for receiving mail from the TCEQ. The mailing address must be recognized by the US Postal Service. You may verify the address on the following website: <https://tools.usps.com/go/ZipLookupAction!input.action>.

The phone number should provide contact to the applicant.

The fax number and e-mail address are optional and should correspond to the applicant.

d) Type of Customer (Entity Type)

Check only one box that identifies the type of entity. Use the descriptions below to identify the appropriate entity type. Note that the selected entity type also indicates the name that must be provided as an applicant for an authorization.

Individual

An individual is a customer who has not established a business, but conducts an activity that needs to be regulated by the TCEQ.

Partnership

A customer that is established as a partnership as defined by the Texas Secretary of State Office (TX SOS). If the customer is a 'General Partnership' or 'Joint Venture' filed in the county (not filed with TX SOS), the legal name of each partner forming the 'General Partnership' or 'Joint Venture' must be provided. Each 'legal entity' must apply as a co-applicant.

Trust or Estate

A trust and an estate are fiduciary relationships governing the trustee/executor with respect to the trust/estate property.

Sole Proprietorship (DBA)

A sole proprietorship is a customer that is owned by only one person and has not been incorporated. This business may:

1. be under the person's name
2. have its own name (doing business as or DBA)
3. have any number of employees.

If the customer is a Sole Proprietorship or DBA, the 'legal name' of the individual business 'owner' must be provided. The DBA name is not recognized as the 'legal name' of the entity. The DBA name may be used for the site name (regulated entity).

Corporation

A customer that meets all of these conditions:

1. is a legally incorporated entity under the laws of any state or country
2. is recognized as a corporation by the Texas Secretary of State
3. has proper operating authority to operate in Texas

The corporation's 'legal name' as filed with the Texas Secretary of State must be provided as applicant. An 'assumed' name of a corporation is not recognized as the 'legal name' of the entity.

Government

Federal, state, county, or city government (as appropriate)

The customer is either an agency of one of these levels of government or the governmental body itself. The government agency's 'legal name' must be provided as the applicant. A department name or other description of the organization is not recognized as the 'legal name'.

Other

This may include a utility district, water district, tribal government, college district, council of governments, or river authority. Provide the specific type of government.

e) Independent Entity

Check No if this customer is a subsidiary, part of a larger company, or is a governmental entity. Otherwise, check Yes.

f) Number of Employees

Check one box to show the number of employees for this customer's entire company, at all locations. This is not necessarily the number of employees at the site named in the application.

g) Customer Business Tax and Filing Numbers

These are required for Corporations and Limited Partnerships. These are not required for Individuals, Government, and Sole Proprietors.

State Franchise Tax ID Number

Corporations and limited liability companies that operate in Texas are issued a franchise tax identification number. If this customer is a corporation or limited liability company, enter the Tax ID number.

Federal Tax ID

All businesses, except for some small sole proprietors, individuals, or general partnerships should have a federal taxpayer identification number (TIN). Enter this number here. Use no prefixes, dashes, or hyphens. Sole proprietors, individuals, or general partnerships do not need to provide a federal tax ID.

TX SOS Charter (filing) Number

Corporations and Limited Partnerships required to register with the Texas Secretary of State are issued a charter or filing number. You may obtain further information by calling SOS at 512-463-5555.

DUNS Number

Most businesses have a DUNS (Data Universal Numbering System) number issued by Dun and Bradstreet Corp. If this customer has one, enter it here.

Section 2. APPLICATION CONTACT

Provide the name and contact information for the person that TCEQ can contact for additional information regarding this application.

Section 3. REGULATED ENTITY (RE) INFORMATION ON PROJECT OR SITE

a) Regulated Entity Number (RN)

The RN is issued by TCEQ's Central Registry to sites where an activity is regulated by TCEQ. This is not a permit number, registration number, or license number. Search TCEQ's Central Registry to see if the site has an assigned RN at <http://www15.tceq.texas.gov/crpub/>. If this regulated entity has not been assigned an RN, leave this space blank.

If the site of your business is part of a larger business site, an RN may already be assigned for the larger site. Use the RN assigned for the larger site.

If the site is found, provide the assigned RN and provide the information for the site to be authorized through this application. The site information for this authorization may vary from the larger site information.

An example is a chemical plant where a unit is owned or operated by a separate corporation that is accessible by the same physical address of your unit or facility. Other examples include industrial parks identified by one common address but different corporations have control of defined areas within the site. In both cases, an RN would be assigned for the physical address location and the permitted sites would be identified separately under the same RN.

b) Name of the Project or Site

Provide the name of the site or project as known by the public in the area where the site is located. The name you provide on this application will be used in the TCEQ Central Registry as the Regulated Entity name.

c) Description of Activity Regulated

In your own words, briefly describe the primary business that you are doing that requires this authorization. Do not repeat the SIC Code description.

d) County

Provide the name of the county where the site or project is located. If the site or project is located in more than one county, provide the county names as secondary.

e) Latitude and Longitude

Enter the latitude and longitude of the site in degrees, minutes, and seconds or decimal form. For help obtaining the latitude and longitude, go to:

<http://www.tceq.texas.gov/gis/sqmaview.html>.

f) Site Address/Location

If a site has an address that includes a street number and street name, enter the complete address for the site in *Section A*. If the physical address is not recognized as a USPS delivery address, you may need to validate the address with your local police (911 service) or through an online map site used to locate a site. Please confirm this to be a complete and valid address. Do not use a rural route or post office box for a site location.

If a site does not have an address that includes a street number and street name, provide a complete written location description in *Section B*. For example: "The site is located on the north side of FM 123, 2 miles west of the intersection of FM 123 and Highway 1."

Provide the city (or nearest city) and zip code of the site location.

Section 4. GENERAL CHARACTERISTICS

a) Indian Country Lands

If your site is located on Indian Country Lands, the TCEQ does not have authority to process your application. You must obtain authorization through EPA Region 6, Dallas. Do not submit this form to TCEQ.

b) Construction activity associated with facility associated with exploration, development, or production of oil, gas, or geothermal resources

If your activity is associated with oil and gas exploration, development, or production, you may be under jurisdiction of the Railroad Commission of Texas (RRC) and may need to obtain authorization from EPA Region 6.

Construction activities associated with a facility related to oil, gas or geothermal resources may include the construction of a well site; treatment or storage facility; underground hydrocarbon or natural gas storage facility; reclamation plant; gas processing facility; compressor station; terminal facility where crude oil is stored prior to refining and at which refined products are stored solely for use at the facility; a carbon dioxide geologic storage facility; and a gathering, transmission, or distribution

pipeline that will transport crude oil or natural gas, including natural gas liquids, prior to refining of such oil or the use of the natural gas in any manufacturing process or as a residential or industrial fuel.

Where required by federal law, discharges of stormwater associated with construction activities under the RRC's jurisdiction must be authorized by the EPA and the RRC, as applicable. Activities under RRC jurisdiction include construction of a facility that, when completed, would be associated with the exploration, development, or production of oil or gas or geothermal resources, such as a well site; treatment or storage facility; underground hydrocarbon or natural gas storage facility; reclamation plant; gas processing facility; compressor station; terminal facility where crude oil is stored prior to refining and at which refined products are stored solely for use at the facility; a carbon dioxide geologic storage facility under the jurisdiction of the RRC; and a gathering, transmission, or distribution pipeline that will transport crude oil or natural gas, including natural gas liquids, prior to refining of such oil or the use of the natural gas in any manufacturing process or as a residential or industrial fuel. The RRC also has jurisdiction over stormwater from land disturbance associated with a site survey that is conducted prior to construction of a facility that would be regulated by the RRC. Under 33 U.S.C. §1342(l)(2) and §1362(24), EPA cannot require a permit for discharges of stormwater from field activities or operations associated with {oil and gas} exploration, production, processing, or treatment operations, or transmission facilities, including activities necessary to prepare a site for drilling and for the movement and placement of drilling equipment, whether or not such field activities or operations may be considered to be construction activities unless the discharge is contaminated by contact with any overburden, raw material, intermediate product, finished product, byproduct, or waste product located on the site of the facility. Under §3.8 of this title (relating to Water Protection), the RRC prohibits operators from causing or allowing pollution of surface or subsurface water. Operators are encouraged to implement and maintain best management practices (BMPs) to minimize discharges of pollutants, including sediment, in stormwater during construction activities to help ensure protection of surface water quality during storm events.

For more information about the jurisdictions of the RRC and the TCEQ, read the Memorandum of Understanding (MOU) between the RRC and TCEQ at 16 Texas Administrative Code, Part 1, Chapter 3, Rule 3.30, by entering the following link into an internet browser:

[http://texreg.sos.state.tx.us/public/readtac\\$ext.TacPage?sl=R&app=9&p_dir=&p_rloc=&p_tloc=&p_ploc=&pg=1&p_tac=&ti=16&pt=1&ch=3&rl=30](http://texreg.sos.state.tx.us/public/readtac$ext.TacPage?sl=R&app=9&p_dir=&p_rloc=&p_tloc=&p_ploc=&pg=1&p_tac=&ti=16&pt=1&ch=3&rl=30) or contact the TCEQ Stormwater Team at 512-239-4671 for additional information.

c) Primary Standard Industrial Classification (SIC) Code

Provide the SIC Code that best describes the construction activity being conducted at this site.

Common SIC Codes related to construction activities include:

- 1521 - Construction of Single Family Homes
- 1522 - Construction of Residential Buildings Other than Single Family Homes
- 1541 - Construction of Industrial Buildings and Warehouses

- 1542 - Construction of Non-residential Buildings, other than Industrial Buildings and Warehouses
- 1611 - Highway and Street Construction, except Highway Construction
- 1622 - Bridge, Tunnel, and Elevated Highway Construction
- 1623 - Water, Sewer, Pipeline and Communications, and Power Line Construction

For help with SIC Codes, enter the following link into your internet browser: <http://www.osha.gov/pls/imis/sicsearch.html> or you can contact the TCEQ Small Business and Local Government Assistance Section at 800-447-2827 for assistance.

d) Secondary SIC Code

Secondary SIC Code(s) may be provided. Leave this blank if not applicable. For help with SIC Codes, enter the following link into your internet browser: <http://www.osha.gov/pls/imis/sicsearch.html> or you can contact the TCEQ Small Business and Environmental Assistance Section at 800-447-2827 for assistance.

e) Total Number of Acres Disturbed

Provide the approximate number of acres that the construction site will disturb. Construction activities that disturb less than one acre, unless they are part of a larger common plan that disturbs more than one acre, do not require permit coverage. Construction activities that disturb between one and five acres, unless they are part of a common plan that disturbs more than five acres, do not require submission of an NOI. Therefore, the estimated area of land disturbed should not be less than five, unless the project is part of a larger common plan that disturbs five or more acres. Disturbed means any clearing, grading, excavating, or other similar activities.

If you have any questions about this item, please contact the stormwater technical staff by phone at 512-239-4671 or by email at swgp@tceq.texas.gov.

f) Common Plan of Development

Construction activities that disturb less than five acres do not require submission of an NOI unless they are part of a common plan of development or for sale where the area disturbed is five or more acres. Therefore, the estimated area of land disturbed should not be less than five, unless the project is part of a larger common plan that disturbs five or more acres. Disturbed means any clearing, grading, excavating, or other similar activities.

For more information on what a common plan of development is, refer to the definition of “Common Plan of Development” in the Definitions section of the general permit or enter the following link into your internet browser: www.tceq.texas.gov/permitting/stormwater/common_plan_of_development_steps.html

For further information, go to the TCEQ stormwater construction webpage enter the following link into your internet browser: www.tceq.texas.gov/goto/construction and search for “Additional Guidance and Quick Links”. If you have any further questions about the Common Plan of Development you can contact the TCEQ Stormwater Team at 512-239-4671 or the TCEQ Small Business and Environmental Assistance at 800-447-2827.

g) Estimated Start Date of the Project

This is the date that any construction activity or construction support activity is initiated at the site. If renewing the permit provide the original start date of when construction activity for this project began.

h) Estimated End Date of the Project

This is the date that any construction activity or construction support activity will end and final stabilization will be achieved at the site.

i) Will concrete truck washout be performed at the site?

Indicate if you expect that operators of concrete trucks will washout concrete trucks at the construction site.

j) Identify the water body(s) receiving stormwater runoff

The stormwater may be discharged directly to a receiving stream or through a MS4 from your site. It eventually reaches a receiving water body such as a local stream or lake, possibly via a drainage ditch. You must provide the name of the water body that receives the discharge from the site (a local stream or lake).

If your site has more than one outfall you need to include the name of the first water body for each outfall, if they are different.

k) Identify the segment number(s) of the classified water body(s)

Identify the classified segment number(s) receiving a discharge directly or indirectly. Enter the following link into your internet browser to find the segment number of the classified water body where stormwater will flow from the site:

www.tceq.texas.gov/waterquality/monitoring/viewer.html or by contacting the TCEQ Water Quality Division at (512) 239-4671 for assistance.

You may also find the segment number in TCEQ publication GI-316 by entering the following link into your internet browser: www.tceq.texas.gov/publications/gi/gi-316 or by contacting the TCEQ Water Quality Division at (512) 239-4671 for assistance.

If the discharge is into an unclassified receiving water and then crosses state lines prior to entering a classified segment, select the appropriate watershed:

- 0100 (Canadian River Basin)
- 0200 (Red River Basin)
- 0300 (Sulfur River Basin)
- 0400 (Cypress Creek Basin)
- 0500 (Sabine River Basin)

Call the Water Quality Assessments section at 512-239-4671 for further assistance.

l) Discharge into MS4 – Identify the MS4 Operator

The discharge may initially be into a municipal separate storm sewer system (MS4). If the stormwater discharge is into an MS4, provide the name of the entity that operates the MS4 where the stormwater discharges. An MS4 operator is often a city, town, county, or utility district, but possibly can be another form of government. Please note that the Construction General Permit requires the Operator to supply the MS4 with a

copy of the NOI submitted to TCEQ. For assistance, you may call the technical staff at 512-239-4671.

m) Discharges to the Edwards Aquifer Recharge Zone and Certification

The general permit requires the approved Contributing Zone Plan or Water Pollution Abatement Plan to be included or referenced as a part of the Stormwater Pollution Prevention Plan.

See maps on the TCEQ website to determine if the site is located within the Recharge Zone, Contributing Zone, or Contributing Zone within the Transition Zone of the Edwards Aquifer by entering the following link into an internet browser: www.tceq.texas.gov/field/eapp/viewer.html or by contacting the TCEQ Water Quality Division at 512-239-4671 for assistance.

If the discharge or potential discharge is within the Recharge Zone, Contributing Zone, or Contributing Zone within the Transition Zone of the Edwards Aquifer, a site-specific authorization approved by the Executive Director under the Edwards Aquifer Protection Program (30 TAC Chapter 213) is required before construction can begin.

For questions regarding the Edwards Aquifer Protection Program, contact the appropriate TCEQ Regional Office. For projects in Hays, Travis and Williamson Counties: Austin Regional Office, 12100 Park 35 Circle, Austin, TX 78753, 512-339-2929. For Projects in Bexar, Comal, Kinney, Medina and Uvalde Counties: TCEQ San Antonio Regional Office, 14250 Judson Rd., San Antonio, TX 78233-4480, 210-490-3096.

Section 5. NOI CERTIFICATION

Note: Failure to indicate Yes to all of the certification items may result in denial of coverage under the general permit.

a) Certification of Understanding the Terms and Conditions of Construction General Permit (TXR150000)

Provisional coverage under the Construction General Permit (TXR150000) begins 7 days after the completed paper NOI is postmarked for delivery to the TCEQ. Electronic applications submitted through ePermits have immediate provisional coverage. You must obtain a copy and read the Construction General Permit before submitting your application. You may view and print the Construction General Permit for which you are seeking coverage at the TCEQ web site by entering the following link into an internet browser: www.tceq.texas.gov/goto/construction or you may contact the TCEQ Stormwater processing Center at 512-239-3700 for assistance.

b) Certification of Legal Name

The full legal name of the applicant as authorized to do business in Texas is required. The name must be provided exactly as filed with the Texas Secretary of State (SOS), or on other legal documents forming the entity, that is filed in the county where doing business. You may contact the SOS at 512-463 5555, for more information related to filing in Texas.

c) Understanding of Notice of Termination

A permittee shall terminate coverage under the Construction General Permit through the submittal of a NOT when the operator of the facility changes, final stabilization has

been reached, the discharge becomes authorized under an individual permit, or the construction activity never began at this site.

d) Certification of Stormwater Pollution Prevention Plan

The SWP3 identifies the areas and activities that could produce contaminated runoff at your site and then tells how you will ensure that this contamination is mitigated. For example, in describing your mitigation measures, your site's plan might identify the devices that collect and filter stormwater, tell how those devices are to be maintained, and tell how frequently that maintenance is to be carried out. You must develop this plan in accordance with the TCEQ general permit requirements. This plan must be developed and implemented before you complete this NOI. The SWP3 must be available for a TCEQ investigator to review on request.

Section 6. APPLICANT CERTIFICATION SIGNATURE

The certification must bear an original signature of a person meeting the signatory requirements specified under 30 Texas Administrative Code (TAC) §305.44.

If you are a corporation:

The regulation that controls who may sign an NOI or similar form is 30 Texas Administrative Code §305.44(a)(1) (see below). According to this code provision, any corporate representative may sign an NOI or similar form so long as the authority to sign such a document has been delegated to that person in accordance with corporate procedures. By signing the NOI or similar form, you are certifying that such authority has been delegated to you. The TCEQ may request documentation evidencing such authority.

If you are a municipality or other government entity:

The regulation that controls who may sign an NOI or similar form is 30 Texas Administrative Code §305.44(a)(3) (see below). According to this code provision, only a ranking elected official or principal executive officer may sign an NOI or similar form. Persons such as the City Mayor or County Commissioner will be considered ranking elected officials. In order to identify the principal executive officer of your government entity, it may be beneficial to consult your city charter, county or city ordinances, or the Texas statute(s) under which your government entity was formed. An NOI or similar document that is signed by a government official who is not a ranking elected official or principal executive officer does not conform to §305.44(a)(3). The signatory requirement may not be delegated to a government representative other than those identified in the regulation. By signing the NOI or similar form, you are certifying that you are either a ranking elected official or principal executive officer as required by the administrative code. Documentation demonstrating your position as a ranking elected official or principal executive officer may be requested by the TCEQ.

If you have any questions or need additional information concerning the signatory requirements discussed above, please contact the TCEQ's Environmental Law Division at 512-239-0600.

30 Texas Administrative Code

§305.44. Signatories to Applications

(a) All applications shall be signed as follows.

(1) For a corporation, the application shall be signed by a responsible corporate officer. For purposes of this paragraph, a responsible corporate officer means a president, secretary, treasurer, or vice-president of the corporation in charge of a principal business function, or any other person who performs similar policy or decision-making functions for the

corporation; or the manager of one or more manufacturing, production, or operating facilities employing more than 250 persons or having gross annual sales or expenditures exceeding \$25 million (in second-quarter 1980 dollars), if authority to sign documents has been assigned or delegated to the manager in accordance with corporate procedures. Corporate procedures governing authority to sign permit or post-closure order applications may provide for assignment or delegation to applicable corporate positions rather than to specific individuals.

(2) For a partnership or sole proprietorship, the application shall be signed by a general partner or the proprietor, respectively.

(3) For a municipality, state, federal, or other public agency, the application shall be signed by either a principal executive officer or a ranking elected official. For purposes of this paragraph, a principal executive officer of a federal agency includes the chief executive officer of the agency, or a senior executive officer having responsibility for the overall operations of a principal geographic unit of the agency (e.g., regional administrator of the EPA).

Texas Commission on Environmental Quality General Permit Payment Submittal Form

Use this form to submit your Application Fee only if you are mailing your payment.

Instructions:

- Complete items 1 through 5 below:
- Staple your check in the space provided at the bottom of this document.
- *Do not mail this form with your NOI form.*
- *Do not mail this form to the same address as your NOI.*

Mail this form and your check to either of the following:

By Regular U.S. Mail

Texas Commission on Environmental Quality
Financial Administration Division
Cashier's Office, MC-214
P.O. Box 13088
Austin, TX 78711-3088

By Overnight or Express Mail

Texas Commission on Environmental Quality
Financial Administration Division
Cashier's Office, MC-214
12100 Park 35 Circle
Austin, TX 78753

Fee Code: GPA General Permit: TXR150000

1. Check or Money Order No: 31641
2. Amount of Check/Money Order: \$6,500.00
3. Date of Check or Money Order: 7/11/2023
4. Name on Check or Money Order: Andy Pape
5. NOI Information:

If the check is for more than one NOI, list each Project or Site (RE) Name and Physical Address exactly as provided on the NOI. **Do not submit a copy of the NOI with this form, as it could cause duplicate permit application entries!**

If there is not enough space on the form to list all of the projects or sites the authorization will cover, then attach a list of the additional sites.

Project/Site (RE) Name: Lemon Creek Ranch Multi-Family

Project/Site (RE) Physical Address:

Staple the check or money order to this form in this space.

Agent Authorization Form
For Required Signature
Edwards Aquifer Protection Program
Relating to 30 TAC Chapter 213
Effective June 1, 1999

I Charlie Malmberg,
Print Name

Managing Director,
Title - Owner/President/Other

of VEP Lemon Creek, LP,
Corporation/Partnership/Entity Name

have authorized Aaron Parenica, P.E.
Print Name of Agent/Engineer

of Kimley-Horn & Associates
Print Name of Firm

to represent and act on the behalf of the above named Corporation, Partnership, or Entity for the purpose of preparing and submitting this plan application to the Texas Commission on Environmental Quality (TCEQ) for the review and approval consideration of regulated activities.

I also understand that:

1. The applicant is responsible for compliance with 30 Texas Administrative Code Chapter 213 and any condition of the TCEQ's approval letter. The TCEQ is authorized to assess administrative penalties of up to \$10,000 per day per violation.
2. For those submitting an application who are not the property owner, but who have the right to control and possess the property, additional authorization is required from the owner.
3. Application fees are due and payable at the time the application is submitted. The application fee must be sent to the TCEQ cashier or to the appropriate regional office. The application will not be considered until the correct fee is received by the commission.
4. A notarized copy of the Agent Authorization Form must be provided for the person preparing the application, and this form must accompany the completed application.
5. No person shall commence any regulated activity on the Edwards Aquifer Recharge Zone, Contributing Zone or Transition Zone until the appropriate application for the activity has been filed with and approved by the Executive Director.

SIGNATURE PAGE:

Charlie Malnberg
Applicant's Signature

8/9/2023
Date

THE STATE OF Texas §

County of Bexar §

BEFORE ME, the undersigned authority, on this day personally appeared Charlie Malnberg known to me to be the person whose name is subscribed to the foregoing instrument, and acknowledged to me that (s)he executed same for the purpose and consideration therein expressed.

GIVEN under my hand and seal of office on this 9 day of August, 2023

Cynthia LaFleur
NOTARY PUBLIC

Cynthia LaFleur
Typed or Printed Name of Notary

MY COMMISSION EXPIRES: 4/17/27

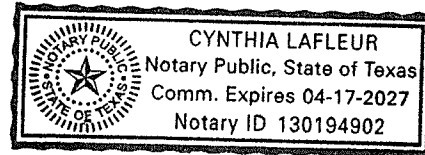

Application Fee Form

Texas Commission on Environmental Quality

Name of Proposed Regulated Entity: Lemon Creek Ranch Multifamily
 Regulated Entity Location: 1723 N Loop 1604 E, Suite 204, San Antonio, TX 78232
 Name of Customer: VEP Lemon Creek, LP
 Contact Person: Charlie Malmberg Phone: (210) 824 -4242
 Customer Reference Number (if issued): CN _____
 Regulated Entity Reference Number (if issued): RN _____

Austin Regional Office (3373)

- Hays Travis Williamson

San Antonio Regional Office (3362)

- Bexar Medina Uvalde
 Comal Kinney

Application fees must be paid by check, certified check, or money order, payable to the **Texas Commission on Environmental Quality**. Your canceled check will serve as your receipt. **This form must be submitted with your fee payment.** This payment is being submitted to:

- Austin Regional Office San Antonio Regional Office
 Mailed to: TCEQ - Cashier Overnight Delivery to: TCEQ - Cashier
 Revenues Section 12100 Park 35 Circle
 Mail Code 214 Building A, 3rd Floor
 P.O. Box 13088 Austin, TX 78753
 Austin, TX 78711-3088 (512)239-0357

Site Location (Check All That Apply):

- Recharge Zone Contributing Zone Transition Zone

<i>Type of Plan</i>	<i>Size</i>	<i>Fee Due</i>
Water Pollution Abatement Plan, Contributing Zone Plan: One Single Family Residential Dwelling	Acres	\$
Water Pollution Abatement Plan, Contributing Zone Plan: Multiple Single Family Residential and Parks	Acres	\$
Water Pollution Abatement Plan, Contributing Zone Plan: Non-residential	Acres	\$ \$6,500
Sewage Collection System	L.F.	\$
Lift Stations without sewer lines	Acres	\$
Underground or Aboveground Storage Tank Facility	Tanks	\$
Piping System(s)(only)	Each	\$
Exception	Each	\$
Extension of Time	Each	\$

Signature: Charlie Malmberg Date: 8/9/23

Application Fee Schedule

Texas Commission on Environmental Quality

Edwards Aquifer Protection Program 30 TAC Chapter 213 (effective 05/01/2008)

Water Pollution Abatement Plans and Modifications

Contributing Zone Plans and Modifications

<i>Project</i>	<i>Project Area in Acres</i>	<i>Fee</i>
One Single Family Residential Dwelling	< 5	\$650
Multiple Single Family Residential and Parks	< 5	\$1,500
	5 < 10	\$3,000
	10 < 40	\$4,000
	40 < 100	\$6,500
	100 < 500	\$8,000
	≥ 500	\$10,000
Non-residential (Commercial, industrial, institutional, multi-family residential, schools, and other sites where regulated activities will occur)	< 1	\$3,000
	1 < 5	\$4,000
	5 < 10	\$5,000
	10 < 40	\$6,500
	40 < 100	\$8,000
	≥ 100	\$10,000

Organized Sewage Collection Systems and Modifications

<i>Project</i>	<i>Cost per Linear Foot</i>	<i>Minimum Fee- Maximum Fee</i>
Sewage Collection Systems	\$0.50	\$650 - \$6,500

Underground and Aboveground Storage Tank System Facility Plans and Modifications

<i>Project</i>	<i>Cost per Tank or Piping System</i>	<i>Minimum Fee- Maximum Fee</i>
Underground and Aboveground Storage Tank Facility	\$650	\$650 - \$6,500

Exception Requests

<i>Project</i>	<i>Fee</i>
Exception Request	\$500

Extension of Time Requests

<i>Project</i>	<i>Fee</i>
Extension of Time Request	\$150



TCEQ Use Only

TCEQ Core Data Form

For detailed instructions regarding completion of this form, please read the Core Data Form Instructions or call 512-239-5175.

SECTION I: General Information

1. Reason for Submission (If other is checked please describe in space provided.)		
<input checked="" type="checkbox"/> New Permit, Registration or Authorization (Core Data Form should be submitted with the program application.)		
<input type="checkbox"/> Renewal (Core Data Form should be submitted with the renewal form)	<input type="checkbox"/> Other	
2. Customer Reference Number (if issued)	Follow this link to search for CN or RN numbers in Central Registry**	3. Regulated Entity Reference Number (if issued)
CN		RN

SECTION II: Customer Information

4. General Customer Information	5. Effective Date for Customer Information Updates (mm/dd/yyyy)	08/22/2023	
<input type="checkbox"/> New Customer <input type="checkbox"/> Update to Customer Information <input type="checkbox"/> Change in Regulated Entity Ownership <input type="checkbox"/> Change in Legal Name (Verifiable with the Texas Secretary of State or Texas Comptroller of Public Accounts)			
<i>The Customer Name submitted here may be updated automatically based on what is current and active with the Texas Secretary of State (SOS) or Texas Comptroller of Public Accounts (CPA).</i>			
6. Customer Legal Name (If an individual, print last name first: eg: Doe, John)		<i>If new Customer, enter previous Customer below:</i>	
VEP Lemon Creek LP			
7. TX SOS/CPA Filing Number	8. TX State Tax ID (11 digits)	9. Federal Tax ID (9 digits)	10. DUNS Number (if applicable)
11. Type of Customer: <input type="checkbox"/> Corporation <input type="checkbox"/> Individual Partnership: <input type="checkbox"/> General <input checked="" type="checkbox"/> Limited			
Government: <input type="checkbox"/> City <input type="checkbox"/> County <input type="checkbox"/> Federal <input type="checkbox"/> State <input type="checkbox"/> Other		<input type="checkbox"/> Sole Proprietorship <input checked="" type="checkbox"/> Other: Limited Partnership (LP)	
12. Number of Employees		13. Independently Owned and Operated?	
<input checked="" type="checkbox"/> 0-20 <input type="checkbox"/> 21-100 <input type="checkbox"/> 101-250 <input type="checkbox"/> 251-500 <input type="checkbox"/> 501 and higher		<input checked="" type="checkbox"/> Yes <input type="checkbox"/> No	
14. Customer Role (Proposed or Actual) – as it relates to the Regulated Entity listed on this form. Please check one of the following			
<input checked="" type="checkbox"/> Owner <input type="checkbox"/> Operator <input type="checkbox"/> Owner & Operator <input type="checkbox"/> Occupational Licensee <input checked="" type="checkbox"/> Responsible Party <input type="checkbox"/> Voluntary Cleanup Applicant <input type="checkbox"/> Other:			
15. Mailing Address:	1723 N Loop 1604 E		
	Suite 204		
	City	San Antonio	State TX ZIP 78232 ZIP + 4
16. Country Mailing Information (if outside USA)		17. E-Mail Address (if applicable)	
18. Telephone Number	19. Extension or Code	20. Fax Number (if applicable)	
(210) 824-4242		() -	

SECTION III: Regulated Entity Information

21. General Regulated Entity Information (If 'New Regulated Entity' is selected below this form should be accompanied by a permit application)	
<input checked="" type="checkbox"/> New Regulated Entity <input type="checkbox"/> Update to Regulated Entity Name <input type="checkbox"/> Update to Regulated Entity Information	
<i>The Regulated Entity Name submitted may be updated in order to meet TCEQ Agency Data Standards (removal of organizational endings such as Inc, LP, or LLC).</i>	
22. Regulated Entity Name (Enter name of the site where the regulated action is taking place.)	
Lemon Creek Ranch Multi-family Apartments	

23. Street Address of the Regulated Entity: <i>(No PO Boxes)</i>	9405 Dietz Elkhorn Road						
	City	San Antonio, ETJ	State	TX	ZIP	78006	ZIP + 4
24. County	Bexar						

Enter Physical Location Description if no street address is provided.

25. Description to Physical Location:	Approximately 12.2 acres located generally and approximately .15 miles east of IH-10 and north of Dietz-Elkhorn Road and south of the Bexar county line.						
26. Nearest City	Fair Oaks			State	TX	Nearest ZIP Code	78015
27. Latitude (N) In Decimal:	29.732889		28. Longitude (W) In Decimal:	90.677125			
Degrees	Minutes	Seconds	Degrees	Minutes	Seconds		
29	43	58.40	98	40	37.65		
29. Primary SIC Code (4 digits)	30. Secondary SIC Code (4 digits)	31. Primary NAICS Code (5 or 6 digits)		32. Secondary NAICS Code (5 or 6 digits)			
1531	6531	531120		531312			
33. What is the Primary Business of this entity? <i>(Do not repeat the SIC or NAICS description.)</i>							
Multi-family apartments							
34. Mailing Address:	1723 N Loop 1604 E						
	Suite 204						
	City	San Antonio	State	TX	ZIP	78232	ZIP + 4
35. E-Mail Address:							
36. Telephone Number		37. Extension or Code		38. Fax Number <i>(if applicable)</i>			
(210) 824-4242				() -			

39. TCEQ Programs and ID Numbers Check all Programs and write in the permits/registration numbers that will be affected by the updates submitted on this form. See the Core Data Form instructions for additional guidance.

<input type="checkbox"/> Dam Safety	<input type="checkbox"/> Districts	<input checked="" type="checkbox"/> Edwards Aquifer	<input type="checkbox"/> Emissions Inventory Air	<input type="checkbox"/> Industrial Hazardous Waste
<input type="checkbox"/> Municipal Solid Waste	<input type="checkbox"/> New Source Review Air	<input type="checkbox"/> OSSF	<input type="checkbox"/> Petroleum Storage Tank	<input type="checkbox"/> PWS
<input type="checkbox"/> Sludge	<input type="checkbox"/> Storm Water	<input type="checkbox"/> Title V Air	<input type="checkbox"/> Tires	<input type="checkbox"/> Used Oil
<input type="checkbox"/> Voluntary Cleanup	<input type="checkbox"/> Waste Water	<input type="checkbox"/> Wastewater Agriculture	<input type="checkbox"/> Water Rights	<input type="checkbox"/> Other:

SECTION IV: Preparer Information

40. Name:	Aaron K. Parenica, P.E.		41. Title:	Project Manager	
42. Telephone Number	43. Ext./Code	44. Fax Number	45. E-Mail Address		
(210) 321-3411		() -	aaron.parenica@kimley-horn.com		

SECTION V: Authorized Signature

46. By my signature below, I certify, to the best of my knowledge, that the information provided in this form is true and complete, and that I have signature authority to submit this form on behalf of the entity specified in Section II, Field 6 and/or as required for the updates to the ID numbers identified in field 39.

Company:	Kimley-Horn and Associates	Job Title:	Authorized Agent
----------	----------------------------	------------	------------------

Name (In Print):	Aaron Parenica, P.E.	Phone:	(210) 321- 3411
Signature:		Date:	8/22/23

STORM WATER POLLUTION PREVENTION PLAN (SWP3)

Lemon Creek Ranch Multifamily

9405 Dietz Elkhorn Road,
San Antonio, ETJ, Texas
Bexar County
Large Construction Activity

JUNE 2023

Project Owner:

VEP Lemon Creek LP

1723 N Loop 1604 E, Suite 204
San Antonio, TX 78232

Project Contractor:

TBD

Prepared By:

Kimley-Horn
10101 Reunion Place, Suite 400
San Antonio, TX 78216
(210) 541-9166

KHA No. 067808807



TABLE OF CONTENTS

1.0	INTRODUCTION	1
	A. Project Name and Location	1
	B. Owner Information	1
	C. Contractor Information	2
	D. Subcontractor Information	2
	E. Discharges Eligible for Authorization	2
	F. Obtaining Coverage under the General Permit.....	3
	G. Notice of Change Letter.....	5
	H. Notice of Termination.....	5
	I. Termination of Coverage for Small Construction	6
	J. SWP3 Availability.....	6
	K. Hazardous Materials.....	6
2.0	SITE DESCRIPTION	7
	A. General Site Description.....	7
	B. Nature of Construction Activity	7
	C. Estimate of Total Site Area and Disturbed Area	7
	D. Storm Water Discharge Locations and Quality Data.....	7
	E. Information on Soil Types	7
	F. Receiving Waters and Wetlands.....	7
	G. Threatened and Endangered Species	8
3.0	BEST MANAGEMENT PRACTICE MEASURES AND CONTROLS	8
	A. General Requirements.....	8
	B. Erosion Control and Stabilization Practices	9
	C. Sediment Control Practices	9
	D. Erosion and Sediment Control Requirements.....	10
6.0	STATE AND LOCAL PROGRAMS	13
7.0	INSPECTION AND MAINTENANCE	14
	A. Inspection Schedule	14
	B. Inspection Reports.....	14
	C. Final Stabilization.....	15
9.0	CONCRETE BATCH PLANTS (IF APPLICABLE)	16
	A. Storm Water Runoff from Concrete Batch Plants	16
	B. Benchmark Sampling Requirements	16
	C. Additional BMP and SWP3 Requirements.....	16
10.0	CONCRETE TRUCK WASH OUT (IF APPLICABLE).....	18
	A. Wash Out Requirements	18
11.0	REFERENCES	19

APPENDICES

- APPENDIX A Project Maps
- APPENDIX B Construction Activity Schedule
- APPENDIX C Best Management Practice Measures and Controls
- APPENDIX D Best Management Practice Checklist and Fact Sheets
- APPENDIX E Inspection and Maintenance Reports
- APPENDIX F Roles and Responsibilities Checklist and Certification Statement
- APPENDIX G TPDES General Permit (TXR150000) for Storm Water Discharges from Construction Activities
- APPENDIX H Site Notice (Small and Large Construction), Notice of Intent, Notice of Change, and Notice of Termination Forms (Large Construction Only)
- APPENDIX I Record of Temporary/Permanent Ceasing of Construction Activities
- APPENDIX J Delegation of Signatories
- APPENDIX K Material Management Practices
- APPENDIX L Non-Storm Water Discharge Inventory
- APPENDIX M Reportable Quantities of Hazardous Substances
- APPENDIX N Sedimentation Basin Information and Calculations
- APPENDIX O Local Requirements
- APPENDIX P Concrete Batch Plant Records

STORM WATER POLLUTION PREVENTION PLAN REVISIONS

Provide a general description and document the date of any revisions to the storm water pollution prevention plan during the course of this construction project. Revisions may be necessary as a result of site inspections or because of a change in the circumstances of the construction project (such as schedule change or a modification in design).

The Storm Water Pollution Prevention Plan (SWP3) must be modified based on the results of inspections, as necessary, to better control pollutants in runoff. Revisions to the SWP3 must be completed within seven (7) calendar days following the inspection. If existing best management practices (BMPs) are modified or if additional BMPs are necessary, an implementation schedule must be described in the SWP3 and wherever possible those changes implemented before the next storm event. If implementation before the next anticipated storm event is impracticable, these changes must be implemented as soon as practicable.

REVISION (Refer to attachments if necessary)	DATE	SIGNATURE

1.0 INTRODUCTION

On March 10, 2003, responsibility for the administration of storm water protection associated with construction activities in Texas was delegated by the U.S. Environmental Protection Agency (EPA) to the Texas Commission on Environmental Quality (TCEQ). The Texas Pollutant Discharge Elimination System (TPDES) program in Texas meets or exceeds the National Pollutant Discharge Elimination System (NPDES) standards established on a federal level. This SWP3 has been developed in accordance with the TPDES requirements. Additional local requirements may apply and this SWP3 should be updated accordingly (Appendix O).

The purpose of the SWP3 is to provide guidelines for preventing or minimizing sediment and other pollutants that may originate on the site from flowing into municipal storm systems or jurisdictional waters during the construction period. This plan also addresses the principal activities known to disturb significant amounts of ground surface during construction. Stabilization measures must begin within fourteen (14) days of stoppage of construction activities (Appendix I). The permit coverage requirements terminate when areas disturbed for this project reach full stabilization (i.e., when disturbed areas are paved or achieve 70 percent native background vegetative coverage). Revisions to this plan will be made as necessary to accurately reflect project activities and storm water pollution prevention measures.

The storm water management controls included in this SWP3 focus on providing control of pollutant discharges with practical approaches that use readily available techniques, expertise, materials, and equipment. The necessary forms for implementing the SWP3 are found in the appendices of this document, including the Inspector's Qualifications, Inspection Form, Notice of Intent (NOI), Notice of Termination (NOT), and construction site notice. All Submittals to TCEQ shall be made electronically (e.g. NOI, NOT, etc.). The SWP3 must be implemented prior to the start of construction activities.

The Project Owner's and the Contractor's roles and responsibilities for implementation and maintenance of the elements of the SWP3 are shown in a checklist in Appendix F of this document. Appendix F also includes a description of primary and secondary operators, along with associated responsibilities. The Project Owner and each Contractor must complete the checklist in Appendix F and sign the included certification statement. The certification statement indicates that each operator understands and accepts their roles and responsibilities with respect to storm water pollution prevention for this project.

A. Project Name and Location

Lemon Creek Ranch Garden Multifamily is within the extra territorial jurisdiction (ETJ) of the City of San Antonio, Bexar County, Texas. It is approximately located .15 miles east of IH-10 and is in between Dietz Elkhorn Rd. and the Bexar county line. (See Appendix A for a project location map).

B. Owner Information

Name: Allen Harrison Company, LLC
Address: 9805 Katy Freeway, Suite 550
Houston, TX 77024
Representative: Will Bood, P.E.
Title: Project Manager
Telephone: (713) 808-1234
Fax: N/A

C. Contractor Information

Name: TBD
Address: TBD
TBD
Representative: TBD
Title: TBD
Telephone: TBD
Fax: TBD

D. Subcontractor Information

Name: TBD
Address: TBD
TBD
Representative: TBD
Title: TBD
Telephone: TBD
Fax: TBD

Name: TBD
Address: TBD
TBD
Representative: TBD
Title: TBD
Telephone: TBD
Fax: TBD

E. Discharges Eligible for Authorization

The general permit for construction activities allows for storm water discharges from construction activities, construction support activities, and authorized non-storm water discharges. Under the general permit, construction support activities include, but are not limited to:

- concrete and asphalt batch plants,
- rock crushers,
- equipment staging areas,
- material storage yards,
- material borrow areas, and
- excavated material disposal areas.

Storm water discharges from these construction support activities are authorized under the general permit for construction activities provided:

- the activity is located within one mile of the permitted construction site and is directly supporting the construction activities,
- the SWP3 for the permitted construction activities is developed to include the controls and measures to reduce erosion and discharge of pollutants in storm water runoff from the construction support activities, and

- the construction support activities either do not operate beyond the completion date of the construction activity or, at the time that they do, are authorized under separate Texas Pollutant Discharge Elimination System (TPDES) authorization.

The following non-storm water discharges are also authorized under the general permit for construction activities:

- Discharges from firefighting activities,
- Uncontaminated fire hydrant flushings,
- Water from routine external washing of vehicles, the external portion of buildings or structures, and pavement (where detergents and soaps are not used),
- Uncontaminated water used to control dust,
- Potable water sources, including waterline flushings,
- Uncontaminated air conditioning condensate,
- Uncontaminated groundwater or spring water, and
- Lawn watering and similar Irrigation drainage.

Part II.A.3 of the general permit contains additional information and requirements for non-storm water discharges. Discharges of storm water runoff from concrete batch plants may be authorized provided that the benchmark sampling and associated requirements located in Part V of the general permit are met. The wash out of concrete trucks associated with off-site facilities may be conducted in accordance with the requirements of Part V of the general permit. The Operator will be responsible for updating the SWP3 to meet Part V requirements, if applicable. A non-storm water discharge inventory is located in Appendix L.

F. Obtaining Coverage under the General Permit

According to the general permit, large construction activities are defined as projects that include clearing, grading, and excavating that result in land disturbance of equal to or greater than five (5) acres of land. Large construction activity also includes the disturbance of less than five (5) acres of total land area that is part of a larger common plan of development or sale if the larger common plan will ultimately disturb equal to or greater than five (5) acres of land.

Large construction activity does not include routine maintenance that is performed to maintain the original line and grade, hydraulic capacity, or original purpose of the site (for example, the routine grading of existing dirt roads, asphalt overlays of existing roads, the routine clearing of existing right-of-ways, and similar maintenance activities.)

Operators of large construction activities that qualify for coverage under the general permit must meet all of the following conditions:

(a) develop a SWP3 according to the provisions of this general permit that covers either the entire site or all portions of the site where the applicant is the operator. The SWP3 must be developed and implemented prior to obtaining coverage and prior to commencing construction activities;

(b) primary operators of large construction activities must submit an NOI prior to commencing construction activity at a construction site. A completed NOI must be submitted to TCEQ electronically using the online e-Permits system on TCEQ's website. Operators with an electronic reporting waiver must submit a completed NOI to TCEQ at least seven (7) days prior to commencing construction activity to obtain provisional coverage seven (7) days from the postmark date for delivery to the TCEQ. An

authorization is no longer provisional when the executive director finds the NOI is administratively complete and an authorization number is issued to the permittee for the construction site indicated on the NOI.

If an additional primary operator is added after the initial NOI is submitted, the additional primary operator must meet the same requirements for existing primary operator(s), as indicated above.

If the primary operator changes due to responsibility at the site being transferred from one primary operator to another after the initial NOI is submitted, the new primary operator must submit a paper NOI or an electronic NOI at least ten (10) days prior to assuming operational control of a construction site and commencing construction activity.

Operators that submit NOIs electronically must use the online e-Permits system available through the TCEQ website.

(c) all operators of large construction activities must post a site notice in accordance with the general permit. The site notice must be located where it is safely and readily available for viewing by the general public, local, state, and federal authorities prior to commencing construction activities, and must be maintained in that location until completion of the construction activity (for linear construction activities, e.g. pipeline or highway, the site notice must be placed in a publicly accessible location near where construction is actively underway; notice for these linear sites may be relocated, as necessary, along the length of the project, and the notice must be safely and readily available for viewing by the general public, local, state, and federal authorities);

(d) two days prior to commencing construction activities, all primary operators must:

- i. provide a copy of the signed NOI to the operator of any MS4 receiving the discharge and to any secondary construction operator, and
- ii. list in the SWP3 the names and addresses of all MS4 operators receiving a copy;

(e) all persons meeting the definition of “secondary operator” in the general permit are hereby notified that they are regulated under this general permit, but are not required to submit an NOI, provided that a primary operator at the site has submitted an NOI, or prior to commencement of construction activities, a primary operator is required to submit an NOI and the secondary operator has provided notification to the operator(s) of the need to obtain coverage (with records of notification available upon request). Any secondary operator notified under this provision may alternatively submit an NOI under this general permit, may seek coverage under an alternative TPDES individual permit, or may seek coverage under an alternative TPDES general permit if available; and

(f) all secondary operators of large construction activities must post a copy of the signed and certified Secondary Operator construction site notice and provide a copy of the signed and certified site notice to the operator of any MS4 receiving the discharge at least two days prior to the commencement construction activities.

NOTE: Posted site notices may have a redacted signature as long as there is an original signed and certified Secondary Operator construction site notice, with a viewable signature, located on-site and available for review by an applicable regulatory authority.

Effective September 1, 2018, applicants must submit an NOI using the online e-Permits system available through the TCEQ website, or request and obtain a waiver from electronic reporting from the TCEQ. Waivers from electronic reporting are not transferrable and expire on the same date as the authorization to discharge.

Questions about the TPDES construction permit program can be directed to the TCEQ Storm Water and General Permits Team at (512) 239-4515. A copy of the TPDES General Permit (TXR150000) for Storm Water Discharges from Construction Activities has been included in Appendix G for reference.

G. Notice of Change Letter (Large Construction Only)

If relevant information provided in the NOI changes, the operator that has submitted the NOI must submit an NOC to TCEQ at least fourteen (14) days before the change occurs, if possible. Where a 14-day advance notice is not possible, the operator must submit an NOC to TCEQ within 14-days of discovery of the change. If the operator becomes aware that it failed to submit any relevant facts or submitted incorrect information in an NOI, the correct information must be submitted to TCEQ in an NOC within 14 days after discovery. The NOC shall be submitted on a form provided by the executive director, or by letter if an NOC form is not available. A copy of the NOC form or letter must also be placed in the SWP3 and provided to the operator of any MS4 receiving the discharge. A list that includes the names and addresses of all MS4 operators receiving a copy of the NOC (or NOC letter) must be included in the SWP3.

Information on an NOC may include, but is not limited to, the following: a change in the description of the construction project; an increase in the number of acres disturbed (for increases of one or more acres); or the name of the operator (where the name of the operator has changed).

A transfer of operational control from one operator to another, including a transfer of the ownership of a company. Coverage under this general permit is not transferable from one operator to another or one company to another and may not be included in an NOC.

A transfer of ownership of a company may include, but is not limited to, the following: changes to the structure of a company, such as changing from a partnership to a corporation or changing corporation types, so that the filing number (or charter number) that is on record with the Texas Secretary of State must be changed.

An NOC is not required for notifying TCEQ of a decrease in the number of acres disturbed. This information must be included in the SWP3 and retained on site.

Effective September 1, 2018, applicants must submit an NOC using the online e-Permits system available through the TCEQ website, or request and obtain a waiver from electronic reporting from the TCEQ. Waivers from electronic reporting are not transferrable and expire on the same date as the authorization to discharge.

H. Notice of Termination for Large Construction Sites (Large Construction Only)

Authorization under the general permit must be terminated by submitting a completed and signed NOT. Effective September 1, 2018, applicants must submit an NOT using the online e-Permits system available through the TCEQ website, or request and obtain a waiver from electronic reporting from the TCEQ. Waivers from electronic reporting are not transferrable and expire on the same date as the authorization to discharge. A copy of the NOT must be provided to the operator of any municipal separate storm sewer system (MS4) receiving the discharge within thirty (30) days after final stabilization has been achieved on all portions of the site that are the responsibility of the permittee, or another permitted contractor has assumed control over all areas of the site that have not been finally stabilized, or the operator has obtained alternative authorization under an individual TPDES permit or alternative TPDES general permit. The names and addresses of all MS4 operators receiving a copy of the NOT must be recorded in this SWP3 (Appendix H).

I. Termination of Coverage for Small Construction Sites and for Secondary Operators at Large Construction Sites

In order to terminate coverage of the general permit, the operator must remove the site notice and complete the applicable portion of the notice related to removal of the site notice. A copy of the completed site notice must be submitted to the operator of any MS4 receiving site discharge within 30 days of any the following conditions:

- a) final stabilization has been achieved on all portions of the site that are the responsibility of the permittee,
- b) a transfer of operational control has occurred, or
- c) the operator has obtained alternative authorization under an individual TPDES permit or alternative TPDES general permit.

J. SWP3 Availability (Large Construction Only)

This SWP3 must be retained on-site at the construction site, or if the site is inactive or does not have an on-site location to store the plan, a notice must be posted describing the location of the SWP3. This SWP3 must be made readily available at the time of an on-site inspection.

K. Hazardous Materials

The following potential pollutant sources may be present at the site due to the nature of the construction activities. An inventory of materials is located in Appendix L. Controls for potential pollutants are listed and described in Appendices C and D.

- | | |
|-----------------------------------|--------------------------------------|
| - Solvents | - Trash |
| - Stains/paints | - Paving |
| - Fuels | - Concrete curing compound |
| - Oils | - Glue adhesives |
| - Grease | - Joint compound |
| - Pesticides | - Concrete, painting, and brick wash |
| - Fertilizer | - Excavation pump-out water |
| - Sediment/total suspended solids | - Concrete |

2.0 SITE DESCRIPTION

A. General Site Description

The construction site is located in the extra territorial jurisdiction (ETJ) of the City of San Antonio, which is located in Bexar County, Texas (Appendix A). The site covers an area of approximately 12.2 acres and is part of a known larger common plan of development. The site is located within the extra territorial jurisdiction (ETJ) of the City of San Antonio, Bexar County, Texas. It is approximately located .15 miles east of IH-10 and is in between Dietz Elkhorn Rd. and the Bexar county line. Coordinates for the site are approximately N29.732889 latitude and W98.677125 longitude (1983 North American Datum Coordinates).

This site is located over the Edwards Aquifer Contributing Zone or the Recharge Zone and is not located on Indian Country Lands. If information about the Edwards Aquifer Zone or Indian Country Lands changes, the Operator should update this SWP3 accordingly.

B. Nature of Construction Activity

The purpose of the project is to construct a multi-family development that will have approximately 349 total units. The table in Appendix B should be updated to depict the anticipated schedule for the project.

C. Estimate of Total Site Area and Disturbed Area

The amount of area involved in the project is estimated to be 12.2 acres (531,432 SF). On-site and off-site disturbed areas are projected to total approximately 10.3 acres.

D. Storm Water Discharge Locations and Quality Data

The treatment of on-site storm water runoff will be provided by Contech's Jellyfish Filter system, designed in accordance with TCEQ water quality requirements. Ultimately, the on-site runoff will discharge into one proposed outfall located near the northwest corner of the site, outside of the flood plain. Off-site runoff will be conveyed via three conveyance routes. Both the off-site and on-site runoff will discharge into Lemon Creek, which will eventually also outfall to Balcones Creek and then the Cibolo Creek watershed. The site will have erosion control measures such as construction entrance, silt fence, and rock filters.

E. Information on Soil Types

A soils map showing the project site and surrounding area is included in Appendix A. The predominant soil type(s) found on the project site are: Anhalt clay, 0 to 2 percent slopes; Crawford, stony and Bexar soils, 0 to 5 percent slopes. A soils map is located in Appendix A (USDA, 2022).

F. Receiving Waters and Wetlands

Lemon Creek is the direct receiving water for storm water from this project (Appendix A). Lemon Creek borders the northern boundary of our site and flows in an easterly direction until converging with Balcones Creek. Eventually, this water connects with Upper Cibolo Creek. This segment of Upper Cibolo Creek (SEGID: 1908) is listed on the 2020 Texas Integrated Report – Texas 303(d) List as impaired for bacteria in water (Recreation Use).

New sources or new discharges of the constituents of concern to impaired waters are not authorized by the general construction permit (unless otherwise allowable under 30 TAC Chapter 305 and applicable

state law). Impaired waters are those that do not meet applicable water quality standards and are listed on the EPA approved CWA 303(d) list. Pollutants of concern are those for which the water body is listed as impaired.

If discharges are expected to enter into a receiving water body located on the 303(d) list, constituents of concern are those for which the water body is listed as impaired. Discharges of the constituents of concern to impaired water bodies for which there is a total maximum daily load (TMDL) are not eligible for the general permit unless they are consistent with the approved TMDL. The receiving water does not have known published TMDL. Permittees must incorporate the conditions and requirements applicable to their discharges, including monitoring frequency and reporting required by TCEQ rules, into this SWP3 in order to be eligible for coverage under the general permit.

There are no known wetlands on the site. If the Operator discovers what may be wetlands the site, the Operator should update this SWP3 accordingly and take appropriate actions to determine what actions may be required to meet all local, state, and federal regulations.

G. Threatened and Endangered Species

Discharges that would adversely affect a listed endangered or threatened aquatic or aquatic-dependent species or its critical habitat are not authorized by the general construction permit, unless the requirements of the Endangered Species Act are satisfied. This project does not appear to contain suitable habitat for listed species in Bexar County, Texas that would be impacted by the discharges from this project. If information regarding the presence of protected species changes the Operator should consult with the appropriate state or federal agency.

3.0 BEST MANAGEMENT PRACTICE MEASURES AND CONTROLS

In order to manage and reduce soil erosion, sediment loss, construction-generated waste, and construction-related toxic materials, BMPs must be utilized at the construction site. A variety of structural controls, soil stabilization techniques, storm water management controls, dust controls, waste disposal techniques, and “good housekeeping” practices that will be utilized in this construction project are documented in a checklist in Appendix C.

A detailed set of fact sheets for BMPs excerpted from the *Integrated Storm Water Design Manual for Construction* (North Central Texas Council of Governments, 2010) is located in Appendix D. These fact sheets show many examples of BMPs that may be appropriate for the site. If another BMP is being used, include the BMP information in Appendix D. The Contractor is responsible for selecting, implementing, and maintaining BMPs.

A. General Requirements

1. Erosion and sediment controls must be designed to retain sediment on-site to the extent practicable with consideration for local topography, soil type, and rainfall.
2. Control measures must be properly selected, installed, and maintained according to the manufacturer's or designer's specifications.
3. Controls must be developed to minimize the offsite transport of litter, construction debris, and construction materials.

B. Erosion Control and Stabilization Practices

1. Erosion control and stabilization practices may include but are not limited to: establishment of temporary or permanent vegetation, mulching, geotextiles, sod stabilization, vegetative buffer strips, protection of existing trees and vegetation, slope texturing, temporary velocity dissipation devices, flow diversion mechanisms, and other similar measures.
2. Control measures must be properly selected, installed, and maintained according to the manufacturer's or designer's specifications.
 - a) the dates when major grading activities occur,
 - b) the dates when the construction activities temporarily or permanently cease on a portion of the site, and
 - c) the dates when stabilization measures are initiated.

A schedule of construction activities is located in Appendix B. Appendix I contains a record of temporary/permanent ceasing of construction activities.

3. Erosion control and stabilization measures must be initiated as soon as practicable in portions of the site where construction activities have temporarily ceased. Stabilization measures that provide a protective cover must be initiated as soon as practicable in portions of the site where construction activities have permanently ceased. These measures must be initiated no more than 14 days after the construction activity in that portion of the site has temporarily or permanently ceased unless provided for in Part III.F.2.b.iii of the general permit

C. Sediment Control Practices

1. Sites with Drainage Areas of Ten or More Acres
 - a) A sedimentation basin is required, where feasible, for a common drainage location that serves an area with ten (10) or more acres disturbed at one time. Sedimentation basin information is located in Appendix N.
 - b) At a minimum, silt fences, vegetative buffer strips, or equivalent sediment controls are required for all down slope boundaries of the construction area, and for those side slope boundaries deemed appropriate as dictated by individual site conditions.
2. Sites with Drainage Areas Less than Ten Acres
 - a) Sediment traps and sediment basins may be used to control solids in storm water runoff for drainage locations serving less than ten (10) acres. At a minimum, silt fences, vegetative buffer strips, or equivalent sediment controls are required for all down slope boundaries of the construction area, and for those side slope boundaries deemed appropriate as dictated by individual site conditions.
 - b) Alternatively, a sediment basin may be utilized. Sedimentation basin information is located in Appendix N.
3. A description of any measures that will be installed during the construction process to control pollutants in storm water discharges that may occur after construction operations have been completed must be included in the SWP3. Permittees are only responsible for the installation and

maintenance of storm water management measures prior to final stabilization of the site or prior to submission of an NOT.

4. Other required controls and BMPs are listed below. Best management practice checklists and fact sheets are included in Appendices C and D. A non storm water discharge inventory is located in Appendix L.
 - a) Permittees shall minimize, to the extent practicable, the off-site vehicle tracking of sediments and the generation of dust. Permittees must include a description of controls utilized to accomplish this requirement.
 - b) Permittees must include a description of construction and waste materials expected to be stored on-site and a description of controls to minimize pollutants from these materials.
 - c) Permittees must include a description of potential pollutant sources from areas other than construction (such as storm water discharges from dedicated asphalt plants and dedicated concrete batch plants), and a description of controls and measures that will be implemented at those sites to minimize pollutant discharges.
 - d) Permittees shall place velocity dissipation devices at discharge locations and along the length of any outfall channel (i.e., runoff conveyance) to provide a non-erosive flow velocity from the structure to a water course, so that the natural physical and biological characteristics and functions are maintained and protected.
 - e) Permittees shall design and utilize appropriate controls to minimize the offsite transport of suspended sediments and other pollutants if it is necessary to pump or channel standing water from the site.
 - f) Permittees shall ensure that all other required controls and BMPs comply with all the requirements of Part III.G of the TXR150000 general permit.

D. Erosion and Sediment Control Requirements

Except as provided in 40 CFR §§125.30-125.32, any discharge regulated under the general permit, with the exception of sites that obtained waivers based on low rainfall erosivity, must achieve, at a minimum, the following effluent limitations representing the degree of effluent reduction attainable by application of the best practicable control technology available (BPT).

1. *Erosion and sediment controls.* Design, install, and maintain effective erosion controls and sediment controls to minimize the discharge of pollutants. At a minimum, such controls must be designed, installed, and maintained to:

- (a) Control stormwater volume and velocity within the site to minimize soil erosion in order to minimize pollutant discharges;
- (b) Control stormwater discharges, including both peak flowrates and total stormwater volume, to minimize channel and streambank erosion and scour in the immediate vicinity of discharge point(s);
- (c) Minimize the amount of soil exposed during construction activity;
- (d) Minimize the disturbance of steep slopes;
- (e) Minimize sediment discharges from the site. The design, installation, and maintenance of erosion and sediment controls must address factors such as the amount, frequency, intensity and

duration of precipitation, the nature of resulting stormwater runoff, and soil characteristics, including the range of soil particle sizes expected to be present on the site;

(f) If earth disturbance activities are located in close proximity to a surface water in the state, provide and maintain appropriate natural buffers if feasible and as necessary, around surface water in the state, depending on site-specific topography, sensitivity, and proximity to water bodies. Direct stormwater to vegetated areas and maximize stormwater infiltration to reduce pollutant discharges, unless infeasible. If providing buffers is infeasible, the permittee shall document the reason that natural buffers are infeasible and shall implement additional erosion and sediment controls to reduce sediment load;

(g) Preserve native topsoil at the site, unless the intended function of a specific area of the site dictates that the topsoil be disturbed or removed, or it is infeasible; and

(h) Minimize soil compaction. In areas of the construction site where final vegetative stabilization will occur or where infiltration practices will be installed, either:

i. restrict vehicle and equipment use to avoid soil compaction; or

ii. prior to seeding or planting areas of exposed soil that have been compacted, use techniques that condition the soils to support vegetative growth, if necessary and feasible;

(i) TCEQ does not consider stormwater control features (e.g., stormwater conveyance channels, storm drain inlets, sediment basins) to constitute "surface water" for the purposes of triggering the buffer requirement in Part III.G.1.(f) above.

2. Soil stabilization. Stabilization of disturbed areas must, at a minimum, be initiated immediately whenever any clearing, grading, excavating, or other earth disturbing activities have permanently on any portion of the site, or temporarily ceased on any portion of the site and will not resume for a period exceeding 14 calendar days. In the context of this requirement, "immediately" means as soon as practicable, but no later than the end of the next work day, following the day when the earth-disturbing activities have temporarily or permanently ceased. Temporary stabilization must be completed more than 14 calendar days after initiation of soil stabilization measures, and final stabilization must be achieved prior to termination of permit coverage. In arid, semi-arid, and drought-stricken areas where initiating vegetative stabilization measures immediately is infeasible, alternative non-vegetative stabilization measures must be employed as soon as practicable. Refer to Part III.F.2.(b) for complete erosion control and stabilization practice requirements. In limited circumstances, stabilization may not be required if the intended function of a specific area of the site necessitates that it remain disturbed.

3. Dewatering. Discharges from dewatering activities, including discharges from dewatering of trenches and excavations, are prohibited, unless managed by appropriate controls. Examples of appropriate controls are outlined below in Section 4.0 of this SWP3 document.

4. Pollution prevention measures. Design, install, implement, and maintain effective pollution prevention measures to minimize the discharge of pollutants. At a minimum, such measures must be designed, installed, implemented, and maintained to:

a) Minimize the discharge of pollutants from equipment and vehicle washing, wheel wash water, and other wash waters. Wash waters must be treated in a sediment basin or alternative control that provides equivalent or better treatment prior to discharge;

(b) Minimize the exposure of building materials, building products, construction wastes, trash, landscape materials, fertilizers, pesticides, herbicides, detergents, sanitary waste, and other materials present on the site to precipitation and to stormwater;

(c) Minimize the exposure of waste materials by closing waste container lids at the end of the work day. For waste containers that do not have lids, where the container itself is not sufficiently secure enough to prevent the discharge of pollutants absent a cover and could leak, the permittee must provide either a cover (e.g., a tarp, plastic sheeting, temporary roof) to minimize exposure of wastes to precipitation, or a similarly effective means designed to minimize the discharge of pollutants (e.g., secondary containment); and

(d) Minimize the discharge of pollutants from spills and leaks, and implement chemical spill and leak prevention and response procedures.

5. *Prohibited discharges.* The following discharges are prohibited:

(a) Wastewater from wash out of concrete, unless managed by an appropriate control;

(b) Wastewater from wash out and cleanout of stucco, paint, form release oils, curing compounds and other construction materials;

(c) Fuels, oils, or other pollutants used in vehicle and equipment operation and maintenance;

(d) Soaps or solvents used in vehicle and equipment washing; and

(e) Toxic or hazardous substances from a spill or other release.

6. *Surface outlets.* When discharging from basins and impoundments, utilize outlet structures that withdraw water from the surface, unless infeasible.

6.0 STATE AND LOCAL PROGRAMS

The TPDES program meets or exceeds the NPDES standards established on a federal level. This SWP3 has been developed in accordance with the requirements of the TPDES requirements. If applicable, local requirements for the City of San Antonio has been included in Appendix O. If provided, this SWP3 should be updated accordingly.

Storm water from the project construction area discharges into the storm sewer system of the San Antonio Water System (City of San Antonio, Bexar County).

7.0 INSPECTION AND MAINTENANCE

A. Inspection Schedule

1. All disturbed areas, as well as all erosion and sediment control devices, will be inspected by a qualified inspector per one of the following schedules:
 - a) at least every fourteen (14) calendar days and within 24 hours after a rainfall of 0.5 inch or greater, or
 - b) every seven (7) days on the same day of the week each week, regardless of whether or not there has been a rainfall event since the previous inspection.
2. Personnel inspecting the site must meet the qualifications stated in the general permit. Inspections may occur on either schedule provided that this SWP3 reflects the current schedule and that any changes are in accordance with the following:
 - a) the schedule is changed a maximum of one time each month,
 - b) the schedule change must be implemented at the beginning of a calendar month, and
 - c) the reason for the schedule change must be documented in this SWP3 (an inspection schedule form is located in Appendix E).

B. Inspection Reports

1. Within 24 hours of an inspection, the completed inspection reports (Appendix E) will include the following information:
 - a) scope of the inspection,
 - b) date of the inspection,
 - c) name(s) of personnel making the inspection,
 - d) reference to qualifications of inspection personnel,
 - e) observed major construction activities, and
 - f) actions taken as a result of the inspection.
2. All disturbed areas (on and off-site), areas for material storage locations where vehicles enter or exit the site, and all of the erosion and sediment controls that were identified as part of the SWP3 must be inspected. The inspection report must state whether the site was in compliance or identify any incidents of non-compliance. The report will be signed by the qualified inspector in accordance with the TPDES general permit and filed in the SWP3. A sample Inspection Report is included in Appendix E, along with an Inspector Qualification Form. All reports and inspections required by the general construction permit will be completed by a duly authorized representative. A copy of a Delegation of Signatories to Reports letter is included in Appendix J.
3. The operator should correct any damage or deficiencies as soon as practicable after the inspection, but in no case later than seven (7) calendar days after the inspection. If existing BMPs are modified or if additional BMPs are necessary, an implementation schedule must be described in the SWP3,

and wherever possible, those changes implemented before the next storm event or as soon as practicable. A list of maintenance guidelines is included in Appendix E.

4. Inspection reports will be kept in the Operator's file, along with the SWP3, for at least three years from the date that the NOT is submitted to the TCEQ for the construction site (for large construction activities) or from the date that the operator terminates coverage (for small construction activities).

C. Final Stabilization

Final stabilization of the construction site has been achieved when all soil disturbing activities at the site have been completed, and a uniform (e.g., evenly distributed, without large bare areas) perennial vegetative cover with a density of 70 percent of the native background vegetative cover for the area has been established on all unpaved areas and areas not covered by permanent structures. If a vegetative cover cannot be established, equivalent permanent stabilization measures (such as riprap, gabions, or geotextiles) can be employed. When these conditions have been met, BMPs can be removed from the construction area.

9.0 CONCRETE BATCH PLANTS

A. Storm Water Runoff from Concrete Batch Plants

Discharges of storm water runoff from concrete batch plants may be authorized under the general permit provided that the requirements in Part IV of the permit are met (Appendix G). If discharges are not covered under the general permit, then discharges must be authorized under an alternative permit. Authorization for discharge or land disposal of concrete batch plant wastewater must be obtained under an alternative permit.

B. Benchmark Sampling Requirements

Operators of concrete batch plants must sample the storm water runoff from the concrete batch plant according to the requirements of the general permit. A table of benchmark monitoring values is located in Part IV.A. of the general permit. Analytical results that exceed a benchmark value are not a violation of the general construction permit. Results of analyses are indicators that modifications of the SWP3 should be assessed and may be necessary to protect water quality. Benchmark sampling records should be included in Appendix P.

C. Additional BMP and SWP3 Requirements

The following items are additional requirements for concrete batch plants. The Operator is responsible for updating the SWP3 as appropriate. Additional information for concrete batch plant requirements is located in Part IV of the general construction permit. Records and information for the concrete batch plant should be included in Appendix P.

1. A description of potential pollutant sources associated with the concrete batch plant must be kept in the SWP3.
2. The site map in Appendix A must include the following information:
 - a) the location of all outfalls for storm water discharges associated with concrete batch plants;
 - b) a depiction of the drainage area and the direction of flow to the outfall(s);
 - c) structural controls used within the drainage area(s);
 - d) the locations of the following areas associated with concrete batch plants that are exposed to precipitation: vehicle and equipment maintenance activity areas; areas used for the treatment, storage, or disposal of wastes; liquid storage tanks; material process and storage areas; and loading and unloading areas; and
 - e) the locations of the following: any bag house or other dust control device(s); recycle/sedimentation pond, clarifier or other device used for the treatment of facility wastewater; areas with significant materials; and areas where major spills or leaks have occurred.
3. A list of materials handled at the concrete batch plant that may be exposed to storm water and that have a potential to affect the quality of storm water discharges associated with concrete batch plants must be kept in this SWP3.

4. A list of significant spills and leaks of toxic or hazardous pollutants that occurred in areas exposed to storm water and that drain to storm water outfalls associated with concrete batch plants must be developed, maintained, and updated.
5. A summary of existing storm water discharge sampling data must be maintained if available.
6. Good housekeeping measures must be developed and implemented in the area(s) associated with concrete batch plants.
7. Areas where potential spills that can contribute pollutants to storm water runoff, and the drainage areas from these locations must be identified. Include material handling procedures, storage requirements, and use of equipment information. Procedures for cleaning up spills must be identified and made available to the appropriate personnel.
8. Qualified facility personnel must be identified to inspect designated equipment and areas of the facility specified in this SWP3. Inspection frequency must be specified based upon a consideration of the level of concrete production, but must be a minimum of once per month while the facility is in operation. The inspection must take place while the facility is in operation and include all areas that are exposed to storm water at the site. Records of inspections must be maintained in Appendix P.
9. An employee training program must be developed to educate personnel. At a minimum, training must occur prior to the initiation of operation of the concrete batch plant.
10. A description of spills and similar incidents, plus additional information that is obtained regarding the quality and quantity of storm water discharges must be included with this SWP3.
11. Include a narrative consideration for reducing the volume of runoff from concrete batch plants by diverting runoff or otherwise managing runoff, including use of infiltration, detention ponds, retention ponds, or reusing of runoff.
12. At least once per year, one or more qualified personnel shall conduct a compliance evaluation of the plant. Evaluation requirements are listed in Part IV.B.3 of the general permit.

10.0 CONCRETE TRUCK WASH OUT

The wash out of concrete trucks at the construction site is authorized, provided that the requirements in Part V of the general permit are met. Authorization is limited to the land disposal of wash out water from concrete trucks. Any other direct discharge of concrete production waste water must be authorized under a separate general permit or individual permit.

A. Wash Out Requirements

1. Direct discharge of concrete truck wash out water to surface water in the state, including discharge to storm sewers, is prohibited by the general permit.
2. Concrete truck wash out water should be discharged to areas at the construction site where structural controls have been established to prevent direct discharge to surface waters, or to areas that have minimal slope that allow infiltration and filtering of wash out water to prevent direct discharge to surface waters. Structural controls may consist of temporary berms, temporary shallow pits, temporary storage tanks with slow rate release, or other reasonable measures to prevent runoff from the site.
3. Wash out of concrete trucks during rainfall events shall be minimized. The direct discharge of concrete wash out water is prohibited at all times, and the operator should have BMPs sufficient to prevent the discharge of concrete truck wash out as the result of rain.
4. The discharge of wash out water should not cause or contribute to groundwater contamination.
5. The Operator is responsible for showing concrete wash out areas on a map (Appendix A).

11.0 REFERENCES

- North Central Texas Council of Governments (NCTCOG). 2010. Integrated Storm Water Management Technical Manual. http://iswm.nctcog.org/technical_manual.asp.
- Texas Commission on Environmental Quality (TCEQ). 2020 “Edwards Aquifer Map Viewer.” [Online] (accessed on February 20, 2020.) Available URL: <https://www.tceq.texas.gov/gis/edwards-viewer.html>.
- United States Department of Agriculture (USDA). 2020. Soil Survey of Bexar County, Texas. “Web Soil Survey.” [Online] (accessed on February 20, 2020). Available URL: <https://websoilsurvey.nrcs.usda.gov/app>.
- Texas Commission on Environmental Quality (TCEQ). 2020. “Surface Water Quality Viewer” [Online] (accessed February 20, 2020.) Available URL: <https://www.tceq.texas.gov/gis/segments-viewer>.
- Texas Commission on Environmental Quality (TCEQ). 2020. “Draft 2016 Texas Water Quality Inventory and 303(d) List.” [Online] (accessed on February 20, 2020). Available URL: https://www.tceq.texas.gov/assets/public/waterquality/swqm/assess/16txir/2016_303d.pdf
- United States Fish and Wildlife Service (USFWS). 2020. National Wetlands Inventory. “Wetlands Mapper.” [Online] (accessed on February 20, 2020). Available URL: <https://www.fws.gov/wetlands/data/mapper.html>.
- United States Fish and Wildlife Service (USFWS). 2020. Species by County Report of Bexar County, Texas. “ECOS Environmental Conservation Online System.” [Online] (accessed on February 20, 2020). Available URL: <https://www.fws.gov/angered/>.

APPENDIX A
PROJECT MAPS

Map/Figure Notes:

- The Operator is solely responsible for selection, implementation, maintenance, and effectiveness of all BMPs.
- Best management practices shown on the attached figures are suggested controls only. The Operator will record BMPs (whether called out on the original SWP3 or not) directly on the site map.
- If information is not shown or if site conditions change from the attached figures, the Operator is responsible for updating the maps. The following information should be included on maps.
 - drainage patterns and approximate slopes anticipated after major grading activities,
 - areas where soil disturbance will occur,
 - locations of all major structural controls either planned or in place,
 - locations where stabilization practices are expected to be used,
 - locations of off-site material, waste, borrow, fill, or equipment storage areas,
 - surface waters (including wetlands) either adjacent or in close proximity,
 - locations where storm water discharges from the site directly to a surface water body or a MS4, and
 - vehicle wash areas
 - designated points on the site where vehicles will exit onto paved roads
- Where the amount of information required to be included on the map would result in a single map being difficult to interpret, the operator shall develop a series of maps that collectively include the required information.

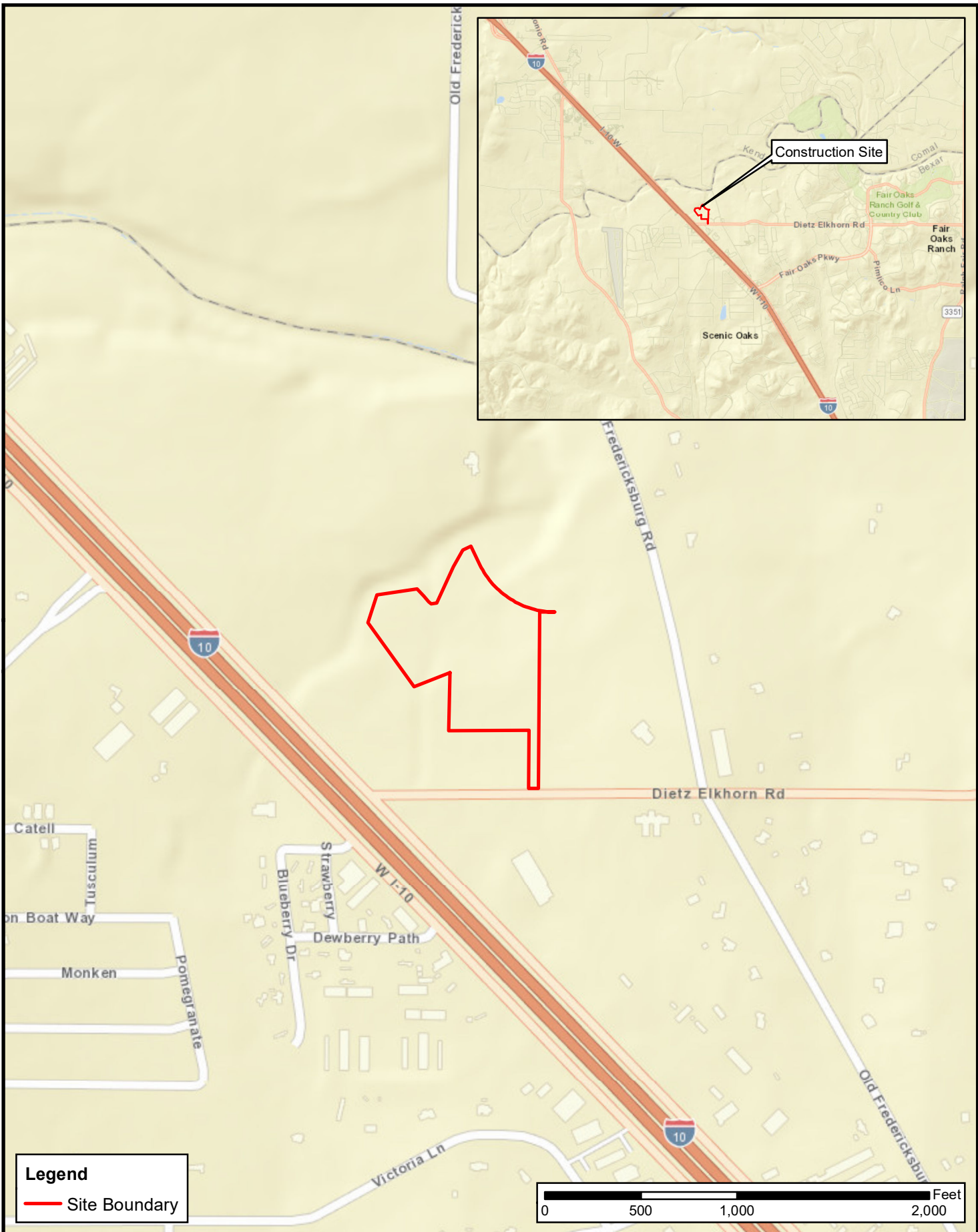

Legend

— Site Boundary

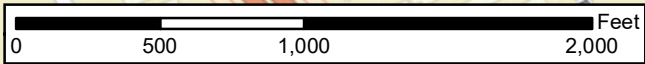

SHEET 1 OF 2 SHEETS	DATE:	03/28/2022
	DESIGN:	JWG
	DRAWN:	JWG
	CHECKED:	AJP
	KHA NO.:	064557101

LOCATION MAP
Attachment A

CZP
Lemon Creek Ranch
Garden Multi-Family
San Antonio ETJ, Bexar County, Texas



Kimley»Horn

This product is for informational purposes and may not have been prepared for or be suitable for legal, engineering, or surveying purposes. It does not represent an on-the-ground survey and represents only the approximate relative location of property boundaries.

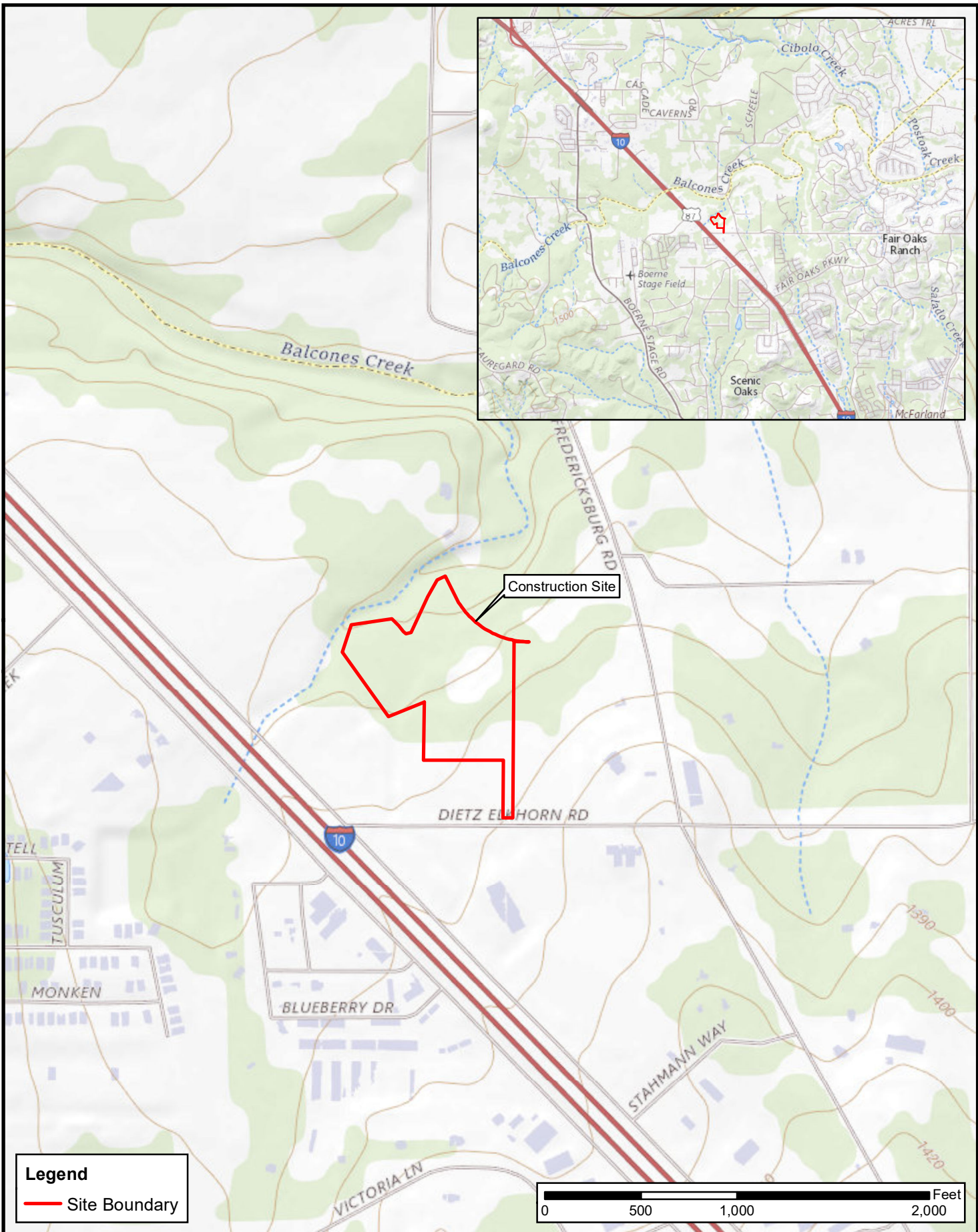

Legend

— Site Boundary

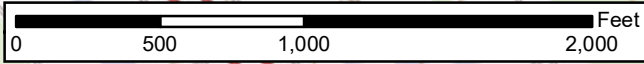

2	DATE:	03/29/2022
	DESIGN:	JWG
	DRAWN:	JWG
	CHECKED:	AJP
	KHA NO.:	064557101

USGS
TOPOGRAPHIC MAP
Attachment B

CZP
Lemon Creek Ranch
Garden Multi-Family
San Antonio ETJ, Bexar County, Texas



Kimley»Horn

This product is for informational purposes and may not have been prepared for or be suitable for legal, engineering, or surveying purposes. It does not represent an on-the-ground survey and represents only the approximate relative location of property boundaries.

National Flood Hazard Layer FIRMette



98°40'45"W 29°44'11"N

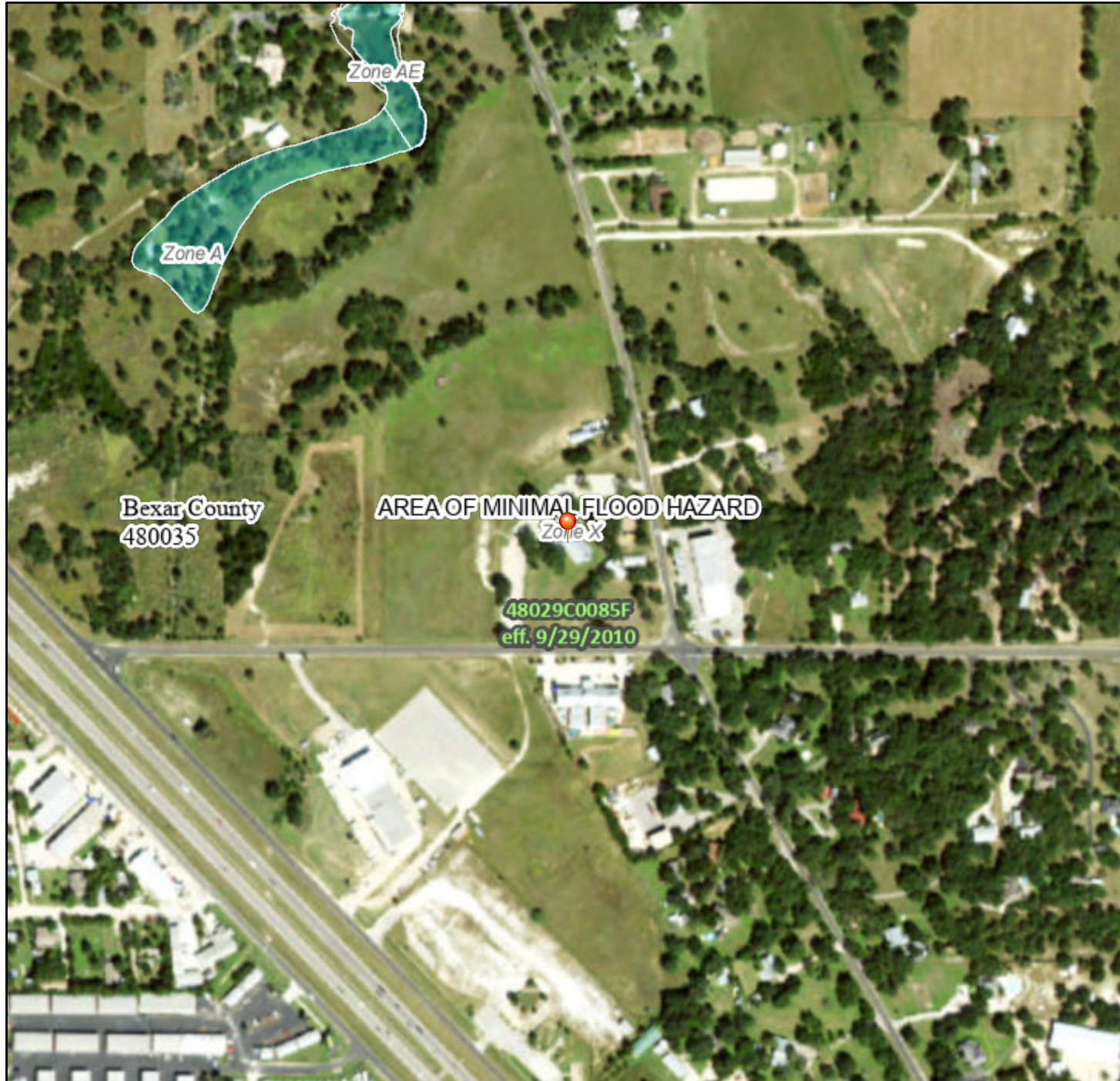

Legend

SEE FIS REPORT FOR DETAILED LEGEND AND INDEX MAP FOR FIRM PANEL LAYOUT

SPECIAL FLOOD HAZARD AREAS		Without Base Flood Elevation (BFE) <i>Zone A, V, A99</i>
		With BFE or Depth <i>Zone AE, AO, AH, VE, AR</i>
		Regulatory Floodway
OTHER AREAS OF FLOOD HAZARD		0.2% Annual Chance Flood Hazard, Areas of 1% annual chance flood with average depth less than one foot or with drainage areas of less than one square mile <i>Zone X</i>
		Future Conditions 1% Annual Chance Flood Hazard <i>Zone X</i>
		Area with Reduced Flood Risk due to Levee. See Notes. <i>Zone X</i>
		Area with Flood Risk due to Levee <i>Zone D</i>
OTHER AREAS		NO SCREEN Area of Minimal Flood Hazard <i>Zone X</i>
		Effective LOMRs
		Area of Undetermined Flood Hazard <i>Zone D</i>
GENERAL STRUCTURES		Channel, Culvert, or Storm Sewer
		Levee, Dike, or Floodwall
OTHER FEATURES		20.2 Cross Sections with 1% Annual Chance
		17.5 Water Surface Elevation
		Coastal Transect
		Base Flood Elevation Line (BFE)
		Limit of Study
		Jurisdiction Boundary
		Coastal Transect Baseline
		Profile Baseline
		Hydrographic Feature
MAP PANELS		Digital Data Available
		No Digital Data Available
		Unmapped
		The pin displayed on the map is an approximate point selected by the user and does not represent an authoritative property location.



This map complies with FEMA's standards for the use of digital flood maps if it is not void as described below. The basemap shown complies with FEMA's basemap accuracy standards

The flood hazard information is derived directly from the authoritative NFHL web services provided by FEMA. This map was exported on **6/7/2022 at 2:19 PM** and does not reflect changes or amendments subsequent to this date and time. The NFHL and effective information may change or become superseded by new data over time.

This map image is void if the one or more of the following map elements do not appear: basemap imagery, flood zone labels, legend, scale bar, map creation date, community identifiers, FIRM panel number, and FIRM effective date. Map images for unmapped and unmodernized areas cannot be used for regulatory purposes.

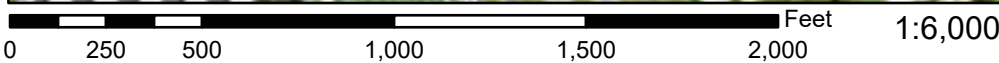

98°40'8"W 29°43'40"N

Soil Map—Bexar County, Texas
(LemonCreekBndy)

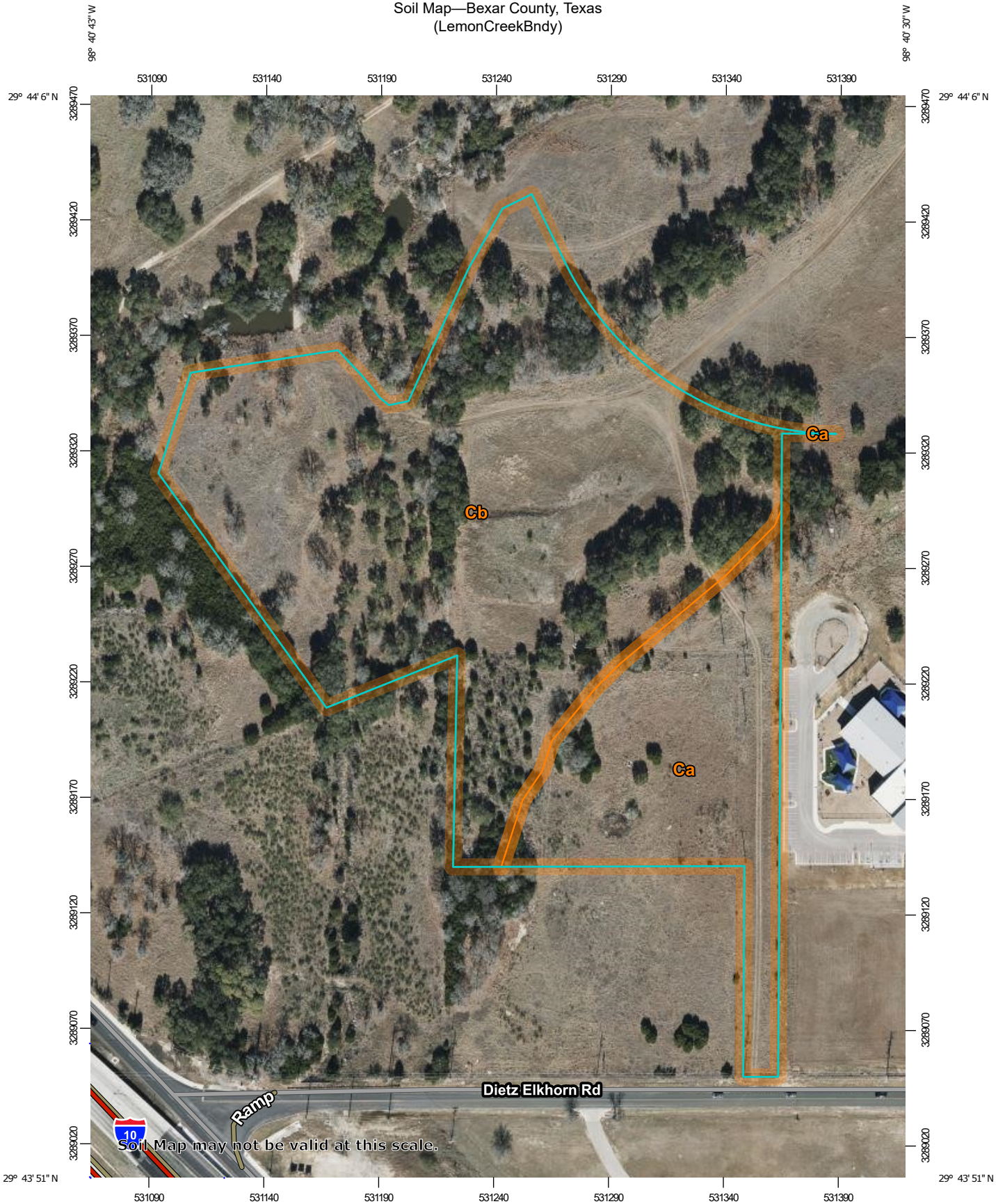

Soil Map may not be valid at this scale.

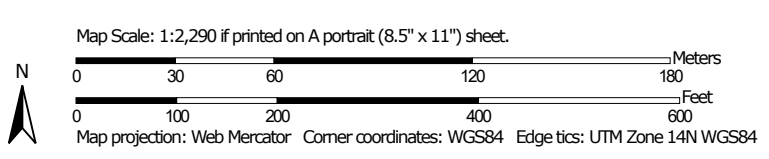

MAP LEGEND

Area of Interest (AOI)

 Area of Interest (AOI)

Soils

 Soil Map Unit Polygons

 Soil Map Unit Lines

 Soil Map Unit Points

Special Point Features



Blowout



Borrow Pit



Clay Spot



Closed Depression



Gravel Pit



Gravelly Spot



Landfill



Lava Flow



Marsh or swamp



Mine or Quarry



Miscellaneous Water



Perennial Water



Rock Outcrop



Saline Spot



Sandy Spot



Severely Eroded Spot



Sinkhole



Slide or Slip



Sodic Spot



Spoil Area



Stony Spot



Very Stony Spot



Wet Spot



Other



Special Line Features

Water Features



Streams and Canals

Transportation



Rails



Interstate Highways



US Routes



Major Roads



Local Roads

Background



Aerial Photography

MAP INFORMATION

The soil surveys that comprise your AOI were mapped at 1:24,000.

Warning: Soil Map may not be valid at this scale.

Enlargement of maps beyond the scale of mapping can cause misunderstanding of the detail of mapping and accuracy of soil line placement. The maps do not show the small areas of contrasting soils that could have been shown at a more detailed scale.

Please rely on the bar scale on each map sheet for map measurements.

Source of Map: Natural Resources Conservation Service
Web Soil Survey URL:
Coordinate System: Web Mercator (EPSG:3857)

Maps from the Web Soil Survey are based on the Web Mercator projection, which preserves direction and shape but distorts distance and area. A projection that preserves area, such as the Albers equal-area conic projection, should be used if more accurate calculations of distance or area are required.

This product is generated from the USDA-NRCS certified data as of the version date(s) listed below.

Soil Survey Area: Bexar County, Texas
Survey Area Data: Version 25, Sep 9, 2021

Soil map units are labeled (as space allows) for map scales 1:50,000 or larger.

Date(s) aerial images were photographed: Dec 17, 2020—Jan 15, 2021

The orthophoto or other base map on which the soil lines were compiled and digitized probably differs from the background imagery displayed on these maps. As a result, some minor shifting of map unit boundaries may be evident.

Map Unit Legend

Map Unit Symbol	Map Unit Name	Acres in AOI	Percent of AOI
Ca	Anhalt clay, 0 to 2 percent slopes	3.1	25.2%
Cb	Crawford, stony and Bexar soils, 0 to 5 percent slopes	9.1	74.8%
Totals for Area of Interest		12.2	100.0%

Bexar County, Texas

Ca—Anhalt clay, 0 to 2 percent slopes

Map Unit Setting

National map unit symbol: 2t2m8

Elevation: 570 to 2,200 feet

Mean annual precipitation: 31 to 36 inches

Mean annual air temperature: 65 to 68 degrees F

Frost-free period: 220 to 260 days

Farmland classification: Prime farmland if irrigated

Map Unit Composition

Anhalt and similar soils: 85 percent

Minor components: 15 percent

Estimates are based on observations, descriptions, and transects of the mapunit.

Description of Anhalt

Setting

Landform: Hillslopes

Landform position (two-dimensional): Toeslope

Landform position (three-dimensional): Base slope

Down-slope shape: Linear

Across-slope shape: Linear

Parent material: Clayey residuum weathered from limestone

Typical profile

Ap - 0 to 12 inches: clay

Bss - 12 to 28 inches: clay

Cr - 28 to 60 inches: bedrock

Properties and qualities

Slope: 0 to 2 percent

Depth to restrictive feature: 20 to 40 inches to paralithic bedrock

Drainage class: Well drained

Runoff class: Very high

Capacity of the most limiting layer to transmit water (Ksat): Very low to moderately low (0.00 to 0.06 in/hr)

Depth to water table: More than 80 inches

Frequency of flooding: None

Frequency of ponding: None

Calcium carbonate, maximum content: 15 percent

Maximum salinity: Nonsaline to very slightly saline (0.0 to 2.0 mmhos/cm)

Available water supply, 0 to 60 inches: Low (about 3.6 inches)

Interpretive groups

Land capability classification (irrigated): None specified

Land capability classification (nonirrigated): 3s

Hydrologic Soil Group: D

Ecological site: R081CY358TX - Deep Redland 29-35 PZ
Hydric soil rating: No

Minor Components

Krum

Percent of map unit: 8 percent
Landform: Stream terraces
Landform position (three-dimensional): Tread
Down-slope shape: Linear
Across-slope shape: Concave
Ecological site: R081CY357TX - Clay Loam 29-35 PZ
Hydric soil rating: No

Tarrant

Percent of map unit: 5 percent
Landform: Hillslopes
Landform position (two-dimensional): Backslope
Landform position (three-dimensional): Side slope
Down-slope shape: Linear
Across-slope shape: Convex, linear
Ecological site: R081CY360TX - Low Stony Hill 29-35 PZ
Hydric soil rating: No

Tarpley

Percent of map unit: 2 percent
Landform: Hillslopes
Landform position (two-dimensional): Footslope
Landform position (three-dimensional): Base slope
Down-slope shape: Linear
Across-slope shape: Linear
Ecological site: R081CY361TX - Redland 29-35 PZ
Hydric soil rating: No

Data Source Information

Soil Survey Area: Bexar County, Texas
Survey Area Data: Version 25, Sep 9, 2021

Bexar County, Texas

Cb—Crawford, stony and Bexar soils, 0 to 5 percent slopes

Map Unit Setting

National map unit symbol: 2ylv8

Elevation: 900 to 1,400 feet

Mean annual precipitation: 30 to 37 inches

Mean annual air temperature: 65 to 70 degrees F

Frost-free period: 220 to 270 days

Farmland classification: Not prime farmland

Map Unit Composition

Crawford, stony, and similar soils: 51 percent

Bexar and similar soils: 36 percent

Minor components: 13 percent

Estimates are based on observations, descriptions, and transects of the mapunit.

Description of Crawford, Stony

Setting

Landform: Hillslopes

Landform position (two-dimensional): Backslope

Landform position (three-dimensional): Side slope

Down-slope shape: Linear

Across-slope shape: Linear

Parent material: Residuum weathered from limestone

Typical profile

A - 0 to 8 inches: stony clay

Bss - 8 to 34 inches: stony clay

R - 34 to 50 inches: bedrock

Properties and qualities

Slope: 0 to 3 percent

Surface area covered with cobbles, stones or boulders: 0.0 percent

Depth to restrictive feature: 21 to 45 inches to lithic bedrock

Drainage class: Well drained

Runoff class: Very high

Capacity of the most limiting layer to transmit water (Ksat): Very low to moderately low (0.00 to 0.06 in/hr)

Depth to water table: More than 80 inches

Frequency of flooding: None

Frequency of ponding: None

Calcium carbonate, maximum content: 2 percent

Maximum salinity: Nonsaline to very slightly saline (0.0 to 2.0 mmhos/cm)

Sodium adsorption ratio, maximum: 2.0

Available water supply, 0 to 60 inches: Low (about 3.7 inches)

Interpretive groups

Land capability classification (irrigated): None specified

Land capability classification (nonirrigated): 4s

Hydrologic Soil Group: D

Ecological site: R081CY358TX - Deep Redland 29-35 PZ

Hydric soil rating: No

Description of Bexar

Setting

Landform: Hillslopes

Landform position (two-dimensional): Backslope

Landform position (three-dimensional): Side slope

Down-slope shape: Linear

Across-slope shape: Linear

Parent material: Residuum weathered from limestone

Typical profile

A1 - 0 to 8 inches: cobbly clay loam

A2 - 8 to 18 inches: very cobbly clay loam

Bt - 18 to 27 inches: cobbly clay

R - 27 to 41 inches: bedrock

Properties and qualities

Slope: 0 to 5 percent

Depth to restrictive feature: 20 to 36 inches to lithic bedrock

Drainage class: Well drained

Runoff class: High

Capacity of the most limiting layer to transmit water

(Ksat): Moderately low to moderately high (0.06 to 0.20 in/hr)

Depth to water table: More than 80 inches

Frequency of flooding: None

Frequency of ponding: None

Maximum salinity: Nonsaline to very slightly saline (0.0 to 2.0 mmhos/cm)

Available water supply, 0 to 60 inches: Very low (about 2.8 inches)

Interpretive groups

Land capability classification (irrigated): None specified

Land capability classification (nonirrigated): 3e

Hydrologic Soil Group: D

Ecological site: R081CY361TX - Redland 29-35 PZ

Hydric soil rating: No

Minor Components

Eckrant

Percent of map unit: 9 percent

Landform: Hillslopes

Landform position (two-dimensional): Shoulder

Landform position (three-dimensional): Side slope

Down-slope shape: Linear

Across-slope shape: Linear

Ecological site: R081CY360TX - Low Stony Hill 29-35 PZ

Hydric soil rating: No

Tarpley

Percent of map unit: 4 percent

Landform: Hillslopes

Landform position (two-dimensional): Shoulder

Landform position (three-dimensional): Side slope

Down-slope shape: Linear

Across-slope shape: Linear

Ecological site: R081CY361TX - Redland 29-35 PZ

Hydric soil rating: No

Data Source Information

Soil Survey Area: Bexar County, Texas

Survey Area Data: Version 25, Sep 9, 2021

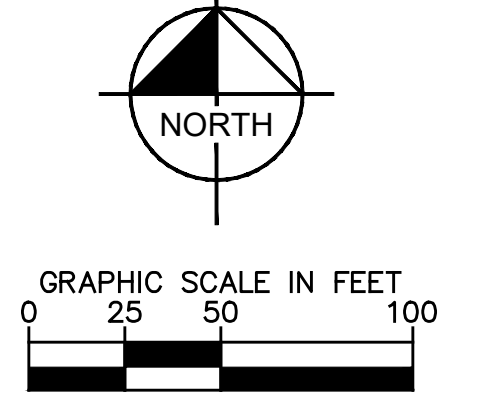
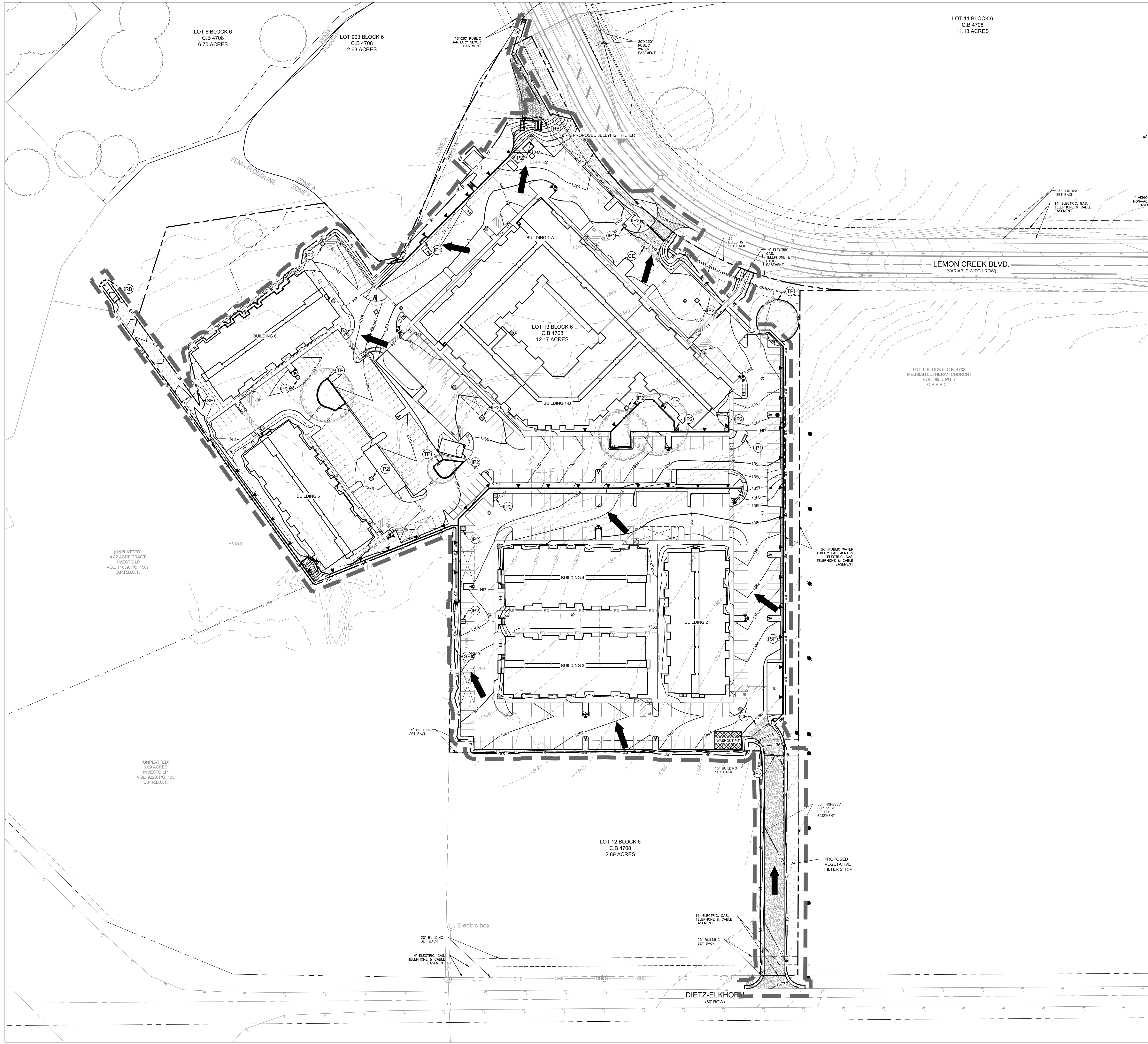

LEGEND

	PROPERTY BOUNDARY
	EXISTING CONTOUR
	PROPOSED CONTOUR
	PROPOSED LIMITS OF DISTURBANCE
	PROPOSED RETAINING WALL (TRIANGLE INDICATES FACE OF WALL)
	DIRECTION OF OVERLAND FLOW W/GRADE
	SILT FENCE (SEE DETAIL SHEET C-1.2)
	TREE PROTECTION (SEE DETAIL SHEET C-1.2)
	CONSTRUCTION EXIT (SEE DETAIL SHEET C-1.2)
	PERMANENT STABILIZATION
	ROCK BERM (SEE DETAIL SHEET C-1.4)
	INLET PROTECTION
	TREE TO REMAIN

- NOTES**
- AREAS CONTAINED WITHIN THE PROPERTY BOUNDARIES WILL BE AREAS OF DISTURBANCE AND SOIL STABILIZATION. ALL SOILS WITHIN THESE LIMITS SHALL BE STABILIZED BY VEGETATION OR STRUCTURE.
 - REFERENCE LANDSCAPE PLANS, BY OTHERS, FOR THE TREE PRESERVATION AND MITIGATION PLAN.

EROSION CONTROL SCHEDULE AND SEQUENCING

I. ROUGH GRADING/ DEMOLITION	CONSTRUCTION ENTRANCE/EXIT, TREE PROTECTION, FILTER DAMS AND SILT FENCE PROTECTION SHALL BE INSTALLED PRIOR TO THE INITIATION OF ROUGH GRADING, AS NEEDED.
II. UTILITY INSTALLATION	ALL PRIOR EROSION CONTROL MEASURES INSTALLED ABOVE TO BE MAINTAINED AS NECESSARY DURING UTILITY INSTALLATION.
III. PAVING	ALL PRIOR EROSION CONTROL MEASURES INSTALLED ABOVE TO BE MAINTAINED AS NECESSARY DURING PAVING AND THROUGHOUT THE REMAINDER OF THE PROJECT.
IV. FINAL GRADING/ SOIL STABILIZATION/ LANDSCAPING	ALL TEMPORARY EROSION CONTROL MEASURES TO BE REMOVED AT THE CONCLUSION OF THE PROJECT AS DIRECTED BY THE CITY OR COUNTY.

THE SEQUENCE OF CONSTRUCTION SHOWN ABOVE IS A GENERAL OVERVIEW AND IS INTENDED TO CONVEY THE GENERAL CONCEPTS OF THE EROSION CONTROL DESIGN AND SHOULD NOT BE RELIED UPON FOR CONSTRUCTION PURPOSES. THE CONTRACTOR IS SOLELY RESPONSIBLE FOR DETAILED PHASING AND CONSTRUCTION SEQUENCING NECESSARY TO CONSTRUCT THE PROPOSED IMPROVEMENTS INCLUDED IN THESE PLANS. THE CONTRACTOR SHALL NOTIFY ENGINEERS IN WRITING IMMEDIATELY, PRIOR TO AND/OR DURING CONSTRUCTION IF ANY ADDITIONAL INFORMATION ON THE CONSTRUCTION SEQUENCE IS NECESSARY. CONTRACTOR IS SOLELY RESPONSIBLE FOR COMPLYING WITH THE REQUIREMENTS OF THE AUTHORITY HAVING JURISDICTION AND ALL OTHER APPLICABLE LAWS.

SITE DATA

TOTAL LOT AREA	12.168 AC	530,052 SF
TOTAL AREA DISTURBED *	10.348 AC	450,738 SF
PAVED AREA	3,248 AC	141,510 SF
ROOFED AREA	3,153 AC	137,329 SF
NEW LANDSCAPED AREA	1,936 AC	84,312 SF

* DOES NOT INCLUDE ANY OFF-SITE DISPOSAL OR BORROW AREAS - CONTRACTOR TO UPDATE AS NECESSARY DURING CONSTRUCTION.

** NO SINGLE DRAINAGE AREA EXCEEDS 10 ACRES, THEREFORE SEDIMENTATION BASIN IS NOT REQUIRED.

NO.	REVISIONS	DATE	BY

Kimley-Horn

©2023 KIMLEY-HORN AND ASSOCIATES, INC. 78216
1000
PHONE: 210-341-9166 FAX: 210-341-9699
WWW.KIMLEY-HORN.COM TUBE FORM NO. 928

AARON K. PARENICA
LICENSED PROFESSIONAL ENGINEER
99323

DATE: 8/29/2023
SCALE: AS SHOWN
DESIGNED BY: AEN
DRAWN BY: MAB
CHECKED BY: AKP

EROSION CONTROL PLAN

LEMON CREEK RANCH MULTI-FAMILY
PREPARED FOR
ALLEN HARRISON CO.
SAN ANTONIO, TX



CAUTION!!!
EXISTING UNDERGROUND UTILITIES IN THE AREA CONTRACTOR IS RESPONSIBLE FOR DETERMINING THE HORIZONTAL AND VERTICAL LOCATION OF ALL UTILITIES PRIOR TO CONSTRUCTION. CONTRACTOR SHALL BE RESPONSIBLE FOR ANY REPAIRS TO EXISTING UTILITIES DUE TO DAMAGE INCURRED DURING CONSTRUCTION. CONTRACTOR SHALL NOTIFY THE ENGINEER OF ANY DISCREPANCIES ON THE PLANS.

Plotted: By: Galvan, Sebastian August 29, 2023 01:42:45pm K:\SNA_CVA\067898607-LOR_MF - Allen Harrison CVA\CAD\PlanSheets\C-EROS-867898607.dwg
 This document, together with the concepts and designs presented herein, is an instrument of service, is intended only for the specific purpose and client for which it was prepared. Reuse of said information and design without written authorization and cooperation by Kimley-Horn and Associates, Inc. shall be without liability to Kimley-Horn and Associates, Inc.

E

D

C

B

A

SF

C1

B

A

CE

A1

IP1

C3

IP2

A3

A4

SITE MAPS - SITE SPECIFIC NOTES

- CONSTRUCTION ENTRANCE SHALL BE LOCATED SO AS TO PROVIDE THE LEAST AMOUNT OF DISTURBANCE TO THE FLOW OF TRAFFIC IN AND OUT OF THE SITE. ADDITIONALLY, CONSTRUCTION ENTRANCE SHALL BE LOCATED TO COINCIDE WITH THE PHASING OF THE PAVEMENT REPLACEMENT.
- THE NATURE OF THIS SITE'S CONSTRUCTION CONSISTS OF:
 - CLEARING AND GRUBBING
 - PRELIMINARY GRADING
 - UTILITY INSTALLATION
 - PAVEMENT CONSTRUCTION
 - BUILDING CONSTRUCTION
 - FINAL GRADING AND STABILIZATION
- THE SUBSURFACE CONDITIONS ON-SITE CONSIST GENERALLY OF DARK BROWN FAT CLAYS, DARK BROWN TO TAN TO YELLOWISH BROWN LEAN CLAYS, BROWN CLAYEY GRAVEL, TAN MARL, PER PROJECT NO. 90215287, PREPARED BY TERRACON CONSULTANTS ON JANUARY 6, 2022.
- STORM WATER ON-SITE WILL LEAVE THE SITE VIA SURFACE FLOW AND UNDERGROUND PIPE.
- POST CONSTRUCTION STORM WATER POLLUTION CONTROL MEASURES INCLUDE STABILIZATION BY PERMANENT PAVING, OR LANDSCAPING.
- VELOCITY DISSIPATION DEVICES (RIP-RAP) WILL BE USED.
- DISTURBED PORTIONS OF SITE MUST BE STABILIZED. STABILIZATION PRACTICES MUST BE INITIATED WITHIN 14 DAYS IN PORTIONS OF THE SITE WHERE CONSTRUCTION HAS BEEN EITHER TEMPORARILY OR PERMANENTLY CEASED, UNLESS EXCEPTED WITHIN THE TPDES PERMIT. CONTRACTOR SHALL REMOVE TEMPORARY EROSION CONTROL DEVICES UPON COMPLETION OF STABILIZATION OR PERMANENT DRAINAGE FACILITIES.
- ACCORDING TO COMMUNITY PANEL NO. 48029C0089F, DATED 02/20/2010 OF THE FEDERAL EMERGENCY MANAGEMENT AGENCY (FEMA) FLOOD INSURANCE RATE MAP (FIRM), A PORTION OF THE SUBJECT TRACT IS LOCATED WITHIN ZONE "A2" WHICH IS DEFINED BY FEMA AS "1% ANNUAL FLOOD CHANCE AREA WITH BASE FLOOD ELEVATIONS DETERMINED". THE REMAINDER OF THE PROPERTY IS WITHIN ZONE "X" (UN-SHADED) DEFINED BY FEMA AS "AREAS DETERMINED TO BE OUTSIDE THE 0.2% ANNUAL CHANCE FLOODPLAIN."
- CONTRACTOR IS RESPONSIBLE FOR MODIFYING THE SWPPP/SITE MAP TO INCLUDE BMPs FOR ANY OFF-SITE MATERIAL WASTE, BORROW OR EQUIPMENT STORAGE AREAS.
- CONTRACTOR SHALL INSPECT DISTURBED AREAS, MATERIAL STORAGE AREAS EXPOSED TO PRECIPITATION, STRUCTURAL CONTROL MEASURES, AND VEHICLE ENTRY AND EXIT AREAS AT LEAST ONCE EVERY 14 CALENDAR DAYS AND WITHIN 24 HOURS OF A STORM EVENT OF 0.5 INCHES OR GREATER.

TEMPORARY EROSION CONTROL NOTES

- THE CONTRACTOR SHALL INSTALL EROSION/SEDIMENTATION CONTROLS AND TREE/NATURAL AREA PROTECTIVE FENCING PRIOR TO ANY SITE PREPARATION WORK (CLEARING, GRUBBING OR EXCAVATION).
- THE PLACEMENT OF EROSION/SEDIMENTATION CONTROLS SHALL BE IN ACCORDANCE WITH THE APPROVED EROSION AND SEDIMENTATION CONTROL PLAN.
- THE PLACEMENT OF TREE/NATURAL AREA PROTECTIVE FENCING SHALL BE IN ACCORDANCE WITH STANDARD NOTES FOR TREE AND NATURAL AREA PROTECTION AND THE APPROVED GRADING/TREE AND NATURAL AREA PLAN.
- A PRE-CONSTRUCTION CONFERENCE SHALL BE HELD ON-SITE WITH THE CONTRACTOR, DESIGN ENGINEER/PERMIT APPLICANT AND ENVIRONMENTAL INSPECTOR AFTER INSTALLATION OF THE EROSION/SEDIMENTATION CONTROLS AND TREE/NATURAL AREA PROTECTIVE MEASURES AND PRIOR TO BEGINNING ANY SITE PREPARATION WORK. THE CONTRACTOR SHALL NOTIFY THE CITY AT LEAST THREE (3) DAYS PRIOR TO THE MEETING DATE.
- ANY MAJOR VARIATION IN MATERIALS OR LOCATIONS OF CONTROLS OR FENCES FROM THOSE SHOWN ON THE APPROVED PLANS WILL REQUIRE A REVISION AND MUST BE APPROVED BY THE REVIEWING ENGINEER, ENVIRONMENTAL SPECIALIST, OR ARBORIST AS APPROPRIATE. MAJOR REVISIONS MUST BE APPROVED BY THE PLANNING AND DEVELOPMENT DEPARTMENT AND THE DRAINAGE UTILITY DEPARTMENT. MINOR CHANGES OR ADDITIONAL CONTROL MEASURES TO BE MADE AS FIELD REVISIONS TO THE EROSION AND SEDIMENTATION CONTROL PLAN MAY BE REQUIRED BY THE ENVIRONMENTAL INSPECTOR DURING THE COURSE OF CONSTRUCTION TO CORRECT CONTROL INADEQUACIES AT NO ADDITIONAL COST TO THE OWNER.
- THE CONTRACTOR IS REQUIRED TO INSPECT THE CONTROLS AND FENCES AT WEEKLY INTERVALS AND AFTER SIGNIFICANT RAINFALL EVENTS TO INSURE THAT THEY ARE FUNCTIONING PROPERLY. THE PERSONS RESPONSIBLE FOR MAINTENANCE OF CONTROLS AND FENCES SHALL IMMEDIATELY MAKE ANY NECESSARY REPAIRS TO DAMAGED AREAS. SILT ACCUMULATION AT CONTROLS MUST BE REMOVED WHEN THE DEPTH REACHES SIX (6) INCHES.

PERMANENT EROSION CONTROL NOTES

ALL DISTURBED AREAS SHALL BE RESTORED AS NOTED BELOW.

- A MINIMUM OF FOUR (4) INCHES OF TOPSOIL SHALL BE PLACED IN ALL DRAINAGE CHANNELS (EXCEPT ROCK) AND BETWEEN THE CURB AND THE RIGHT-OF-WAY.
- THE SEEDING FOR PERMANENT EROSION CONTROL SHALL BE APPLIED OVER AREAS DISTURBED BY CONSTRUCTION AS FOLLOWS:
 - FROM SEPTEMBER 15 TO MARCH 1, SEEDING SHALL BE WITH A COMBINATION OF 2 POUNDS PER 1000 SQUARE FEET OF UNHILLED BERMUDA AND 7 POUNDS PER 1000 SQUARE FEET OF WINTER RYE WITH A PURITY OF 95% WITH 90% GERMINATION.
 - FROM MARCH 2 TO SEPTEMBER 14, SEEDING SHALL BE WITH HILLED BERMUDA AT A RATE OF 2 POUNDS PER 1000 SQUARE FEET WITH A PURITY OF 95% WITH 85% GERMINATION.
 - FERTILIZER SHALL BE A PELLETTED OR GRANULAR SLOW RELEASE WITH AN ANALYSIS OF 15-15-15 TO BE APPLIED ONCE AT PLANTING AND ONCE DURING THE PERIOD OF ESTABLISHMENT AT THE RATE OF 1 POUND PER 1000 SQUARE FEET.
 - MULCH TYPE USED SHALL BE HAY, STRAW OR MULCH APPLIED AT A RATE OF 45 POUNDS PER 1000 SQUARE FEET.

BROADCAST SEEDING:

- FROM SEPTEMBER 15 TO MARCH 1, SEEDING SHALL BE WITH A COMBINATION OF 2 POUNDS PER 1000 SQUARE FEET OF UNHILLED BERMUDA AND 7 POUNDS PER 1000 SQUARE FEET OF WINTER RYE WITH A PURITY OF 95% WITH 90% GERMINATION.
- FROM MARCH 2 TO SEPTEMBER 14, SEEDING SHALL BE WITH HILLED BERMUDA AT A RATE OF 1 POUND PER 1000 SQUARE FEET WITH A PURITY OF 95% WITH 85% GERMINATION.
 - FERTILIZER SHALL BE A WATER SOLUBLE FERTILIZER WITH AN ANALYSIS OF 15-15-15 AT THE RATE OF 1.5 POUNDS PER 1000 SQUARE FEET.
 - MULCH TYPE USED SHALL BE HAY, STRAW OR MULCH APPLIED AT A RATE OF 45 POUNDS PER 1000 SQUARE FEET.
 - THE PLANTED AREA SHALL BE IRRIGATED OR SPRINKLED IN A MANNER THAT WILL NOT ERODE THE TOPSOIL, BUT WILL SUFFICIENTLY SOAK THE SOIL TO A DEPTH OF SIX (6) INCHES. THE IRRIGATION SHALL OCCUR AT TEN-DAY INTERVALS DURING THE FIRST TWO MONTHS. RAINFALL OCCURRENCES OF 1/2 INCH OR MORE SHALL POSTPONE THE WATERING SCHEDULE FOR ONE WEEK.
 - RESTORATION SHALL BE ACCEPTABLE WHEN THE GRASS HAS GROWN AT LEAST 1-1/2 INCHES HIGH WITH 90% COVERAGE, PROVIDED NO BARE SPOTS LARGER THAN 16 SQUARE FEET EXIST.
 - WHEN REQUIRED, NATIVE GRASS SEEDING SHALL COMPLY WITH REQUIREMENTS OF THE ENVIRONMENTAL CRITERIA MANUAL.

HYDRAULIC SEEDING:

- FROM SEPTEMBER 15 TO MARCH 1, SEEDING SHALL BE WITH A COMBINATION OF 2 POUNDS PER 1000 SQUARE FEET OF UNHILLED BERMUDA AND 7 POUNDS PER 1000 SQUARE FEET OF WINTER RYE WITH A PURITY OF 95% WITH 90% GERMINATION.
- FROM MARCH 2 TO SEPTEMBER 14, SEEDING SHALL BE WITH HILLED BERMUDA AT A RATE OF 1 POUND PER 1000 SQUARE FEET WITH A PURITY OF 95% WITH 85% GERMINATION.
 - FERTILIZER SHALL BE A WATER SOLUBLE FERTILIZER WITH AN ANALYSIS OF 15-15-15 AT THE RATE OF 1.5 POUNDS PER 1000 SQUARE FEET.
 - MULCH TYPE USED SHALL BE HAY, STRAW OR MULCH APPLIED AT A RATE OF 45 POUNDS PER 1000 SQUARE FEET.
 - THE PLANTED AREA SHALL BE IRRIGATED OR SPRINKLED IN A MANNER THAT WILL NOT ERODE THE TOPSOIL, BUT WILL SUFFICIENTLY SOAK THE SOIL TO A DEPTH OF SIX (6) INCHES. THE IRRIGATION SHALL OCCUR AT TEN-DAY INTERVALS DURING THE FIRST TWO MONTHS. RAINFALL OCCURRENCES OF 1/2 INCH OR MORE SHALL POSTPONE THE WATERING SCHEDULE FOR ONE WEEK.
 - RESTORATION SHALL BE ACCEPTABLE WHEN THE GRASS HAS GROWN AT LEAST 1-1/2 INCHES HIGH WITH 90% COVERAGE, PROVIDED NO BARE SPOTS LARGER THAN 16 SQUARE FEET EXIST.
 - WHEN REQUIRED, NATIVE GRASS SEEDING SHALL COMPLY WITH REQUIREMENTS OF THE ENVIRONMENTAL CRITERIA MANUAL.

SITE MAP - GENERAL NOTES

- CONTRACTOR IS SOLELY RESPONSIBLE FOR SELECTION, IMPLEMENTATION, MAINTENANCE, AND EFFECTIVENESS OF ALL SWPPP CONTROLS - CONTROLS SHOWN ON THIS SITE MAP ARE SUGGESTED CONTROLS ONLY.
- CONTRACTOR SHALL RECORD INSTALLATION, MAINTENANCE OR MODIFICATION, AND REMOVAL DATES FOR EACH BMP EMPLOYED (WHETHER CALLED OUT ON ORIGINAL SWPPP OR NOT) DIRECTLY ON THE SITE MAP.
- DRAINAGE PATTERNS ARE SHOWN ON THIS PLAN BY PROPOSED AND EXISTING CONTOURS, FLOW ARROWS, AND SLOPES.
- TEMPORARY AND PERMANENT STABILIZATION PRACTICES AND BMPs SHALL BE INSTALLED AT THE EARLIEST POSSIBLE TIME DURING THE CONSTRUCTION SEQUENCE. AS AN EXAMPLE, PERIMETER SILT FENCE SHALL BE INSTALLED BEFORE COMMENCEMENT OF ANY GRADING ACTIVITIES. OTHER BMPs SHALL BE INSTALLED AS SOON AS PRACTICABLE AND SHALL BE MAINTAINED UNTIL FINAL SITE STABILIZATION IS ATTAINED. CONTRACTOR SHALL ALSO REFER TO CIVIL AND LANDSCAPE PLANS SINCE PERMANENT STABILIZATION IS PROVIDED BY LANDSCAPING, THE BUILDING(S), AND SITE PAVING.
- BMPs HAVE BEEN LOCATED AS INDICATED ON THIS PLAN IN ACCORDANCE WITH GENERALLY ACCEPTED ENGINEERING PRACTICES IN ORDER TO MINIMIZE SEDIMENT TRANSFER. FOR EXAMPLE, SILT FENCES LOCATED AT TOE OF SLOPE AND INLET PROTECTION FOR INLETS RECEIVING SEDIMENT FROM SITE RUN-OFF.
- SANITARY SEWER EFFLUENT IS DISPOSED OF VIA AN ONSITE SEWER SYSTEM CONNECTED TO A MUNICIPAL SEWER SYSTEM.

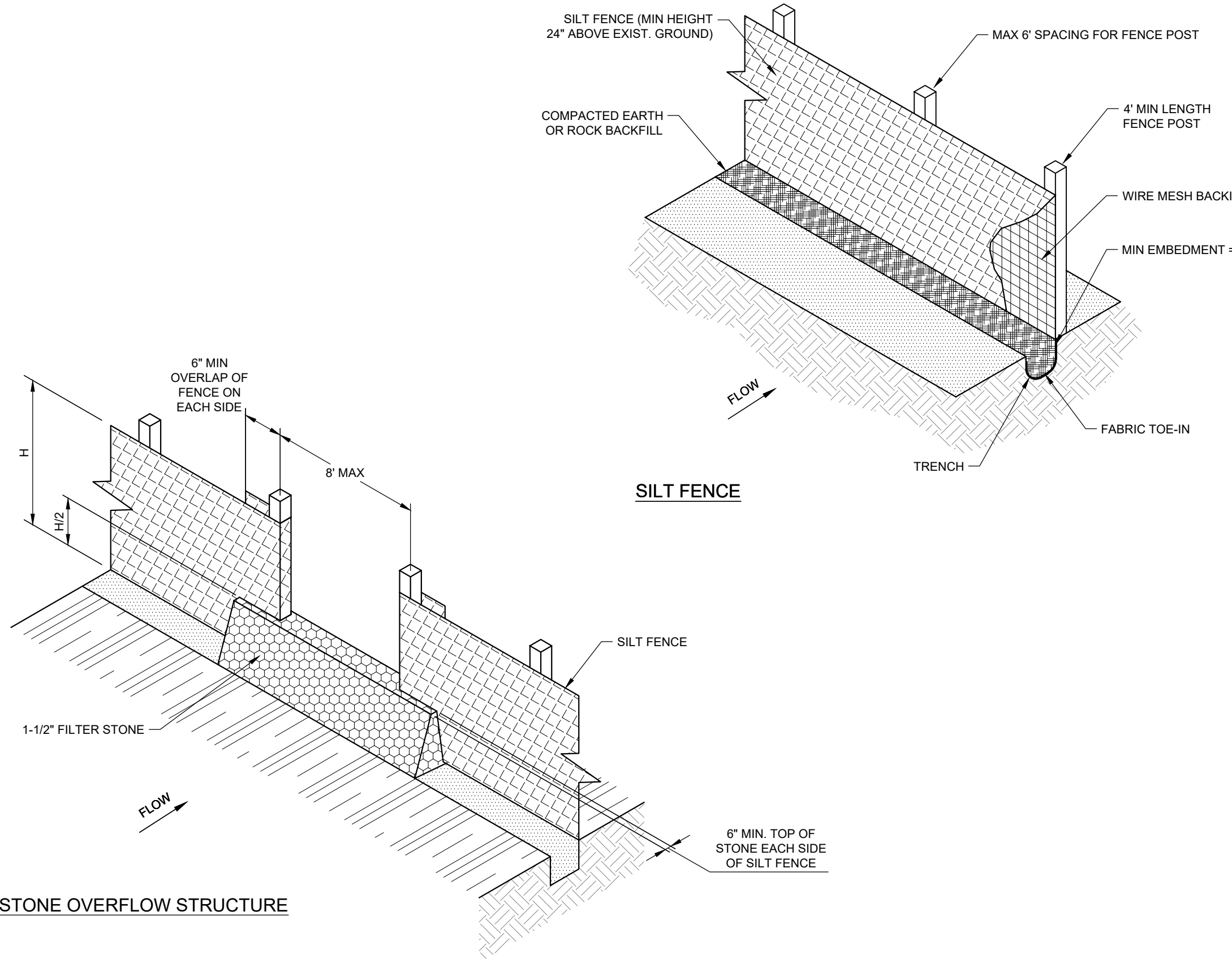

NOTES:

- INSTALL STONE OVERFLOW STRUCTURES AT ALL LOW POINTS AND EVERY 300 FEET WHERE NO LOW POINT IS APPARENT.
- UPLOPE LENGTHS OF SILT FENCE SHALL BE A MINIMUM OF 10 FEET.

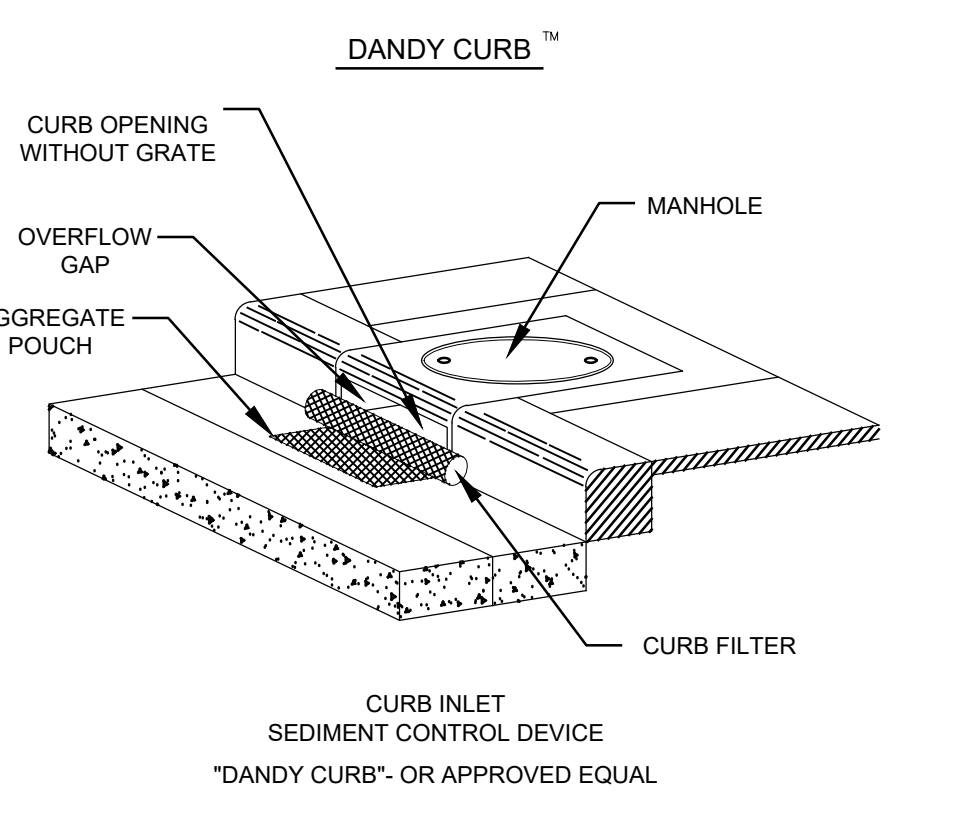

DANDY CURB™ SPECIFICATIONS

NOTE: THE DANDY CURB™ WILL BE MANUFACTURED BY THE U.S.A. FROM A WOVEN WAREHART FABRIC THAT MEETS OR EXCEEDS THE FOLLOWING SPECIFICATIONS: DANDY CURB™ (SAFETY GRASSES)

Mechanical Properties	Test Method	Units	MARY
Grain Tensile Strength	ASTM D 4832	lbm (lbs)	1.42 (345) x 0.89 (200)
Grain Tensile Elongation	ASTM D 4832	in (in)	24 x 10
Proctor Compaction	ASTM D 4832	in (in)	2.67 (68)
Moisture Ratio	ASTM D 4832	in (in)	0.87 (22)
Temporary Tear Strength	ASTM D 4832	in (in)	0.91 (119) x 5.33 (125)
Permeability	ASTM D 4832	in (in)	0.42 (10.8)
Apparent Opening Size	ASTM D 4251	mm (US Sieve)	0.425 (100)
Flow Rightness	ASTM D 4441	1/min (US Sieve)	200 (140)
Permeability	ASTM D 4441	sec	1.0

*Note: All Dandy Curbs™ can be ordered with our optional absorbents.

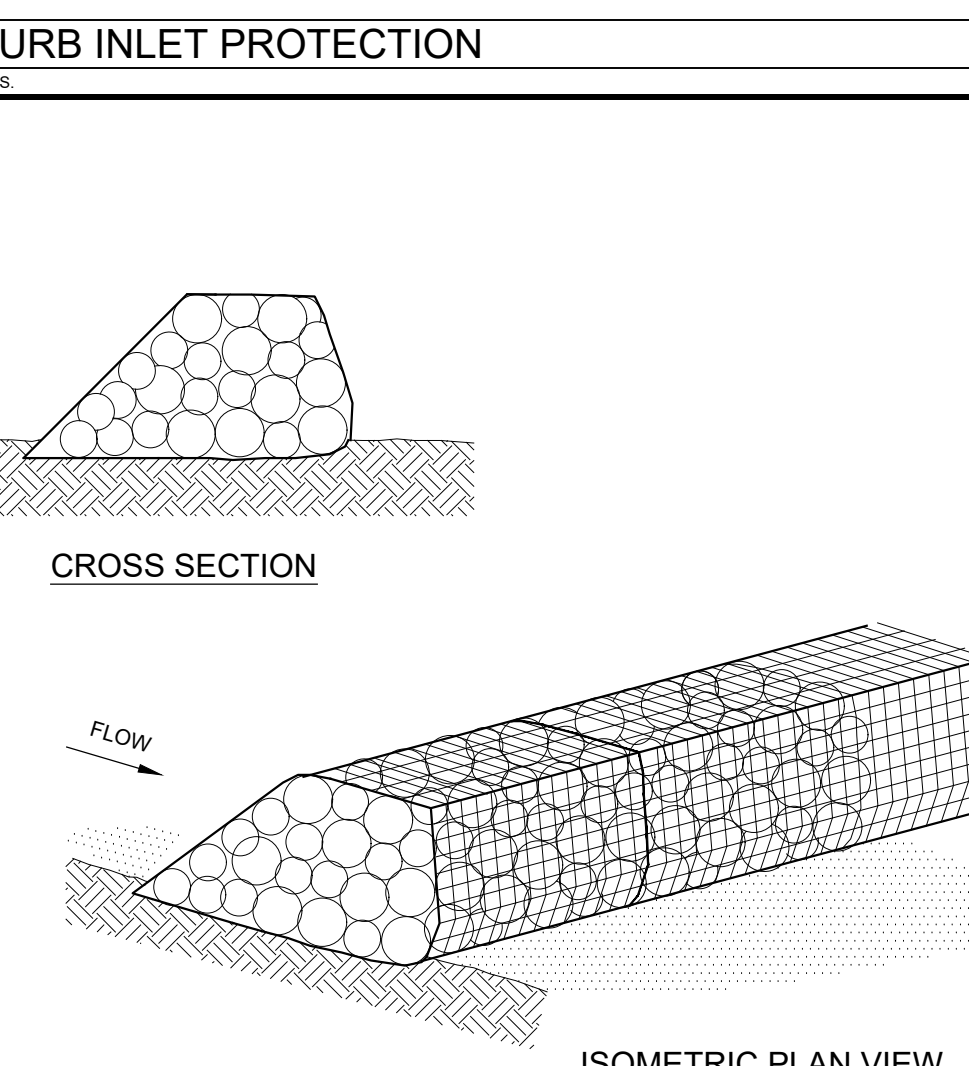

NOTE:

- USE ONLY OPEN GRADED ROCK 4-8 INCHES IN DIAMETER FOR STREAM FLOW CONDITION. USE OPEN GRADED ROCK 3-5 INCHES IN DIAMETER FOR OTHER CONDITIONS.
- THE ROCK BERM SHALL BE SECURED WITH A WOVEN WIRE SHEATHING HAVING A MAXIMUM OPENING OF 1 INCH AND A MINIMUM WIRE SIZE OF 20 GAUGE AND SHALL BE BURIED IN A TRENCH APPROXIMATELY 3 TO 4 INCHES DEEP.
- THE ROCK BERM SHALL BE INSPECTED EVERY TWO WEEKS OR AFTER EACH 1/2" RAIN EVENT AND SHALL BE REPLACED WHEN THE STRUCTURE CEASES TO FUNCTION AS INTENDED DUE TO SILT ACCUMULATION AMONG THE ROCKS, WASHOUT, CONSTRUCTION TRAFFIC DAMAGE, ETC.
- WHEN SILT REACHES A DEPTH EQUAL TO ONE-THIRD OF THE HEIGHT OF THE BERM OR ONE FOOT, WHICHEVER IS LESS, THE SILT SHALL BE REMOVED AND DISPOSED OF PROPERLY.
- WHEN THE SITE IS COMPLETELY STABILIZED, THE BERM AND ACCUMULATED SILT SHALL BE REMOVED AND DISPOSED OF IN AN APPROVED MANNER.
- ROCK BERM SHOULD BE USED AS CHECK DAMS FOR CONCENTRATED FLOW AND ARE NOT INTENDED FOR USE IN PERIMETER PROTECTION.

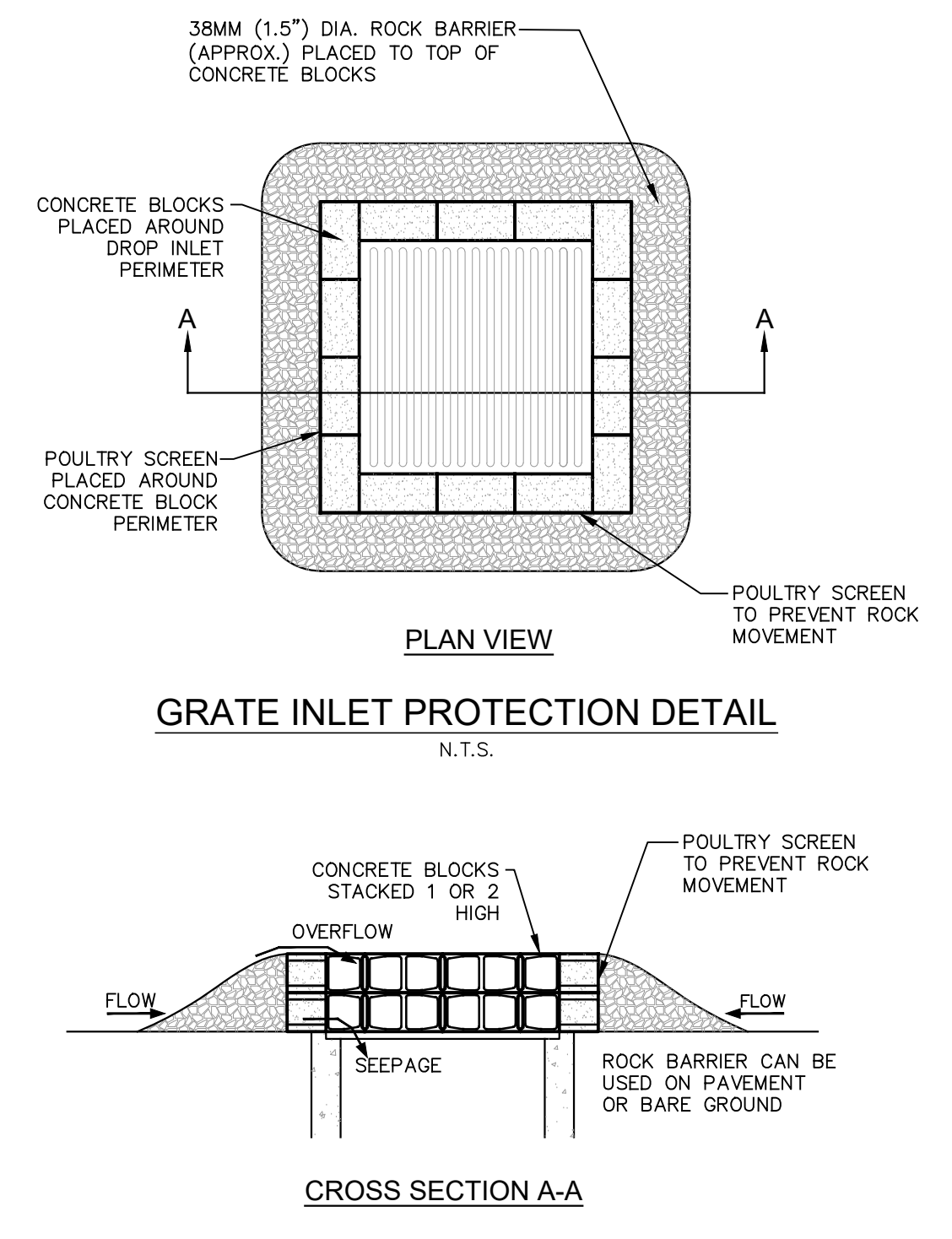

NOTE:

- USE ONLY OPEN GRADED ROCK 4-8 INCHES IN DIAMETER FOR STREAM FLOW CONDITION. USE OPEN GRADED ROCK 3-5 INCHES IN DIAMETER FOR OTHER CONDITIONS.
- THE ROCK BERM SHALL BE SECURED WITH A WOVEN WIRE SHEATHING HAVING A MAXIMUM OPENING OF 1 INCH AND A MINIMUM WIRE SIZE OF 20 GAUGE AND SHALL BE BURIED IN A TRENCH APPROXIMATELY 3 TO 4 INCHES DEEP.
- THE ROCK BERM SHALL BE INSPECTED EVERY TWO WEEKS OR AFTER EACH 1/2" RAIN EVENT AND SHALL BE REPLACED WHEN THE STRUCTURE CEASES TO FUNCTION AS INTENDED DUE TO SILT ACCUMULATION AMONG THE ROCKS, WASHOUT, CONSTRUCTION TRAFFIC DAMAGE, ETC.
- WHEN SILT REACHES A DEPTH EQUAL TO ONE-THIRD OF THE HEIGHT OF THE BERM OR ONE FOOT, WHICHEVER IS LESS, THE SILT SHALL BE REMOVED AND DISPOSED OF PROPERLY.
- WHEN THE SITE IS COMPLETELY STABILIZED, THE BERM AND ACCUMULATED SILT SHALL BE REMOVED AND DISPOSED OF IN AN APPROVED MANNER.
- ROCK BERM SHOULD BE USED AS CHECK DAMS FOR CONCENTRATED FLOW AND ARE NOT INTENDED FOR USE IN PERIMETER PROTECTION.

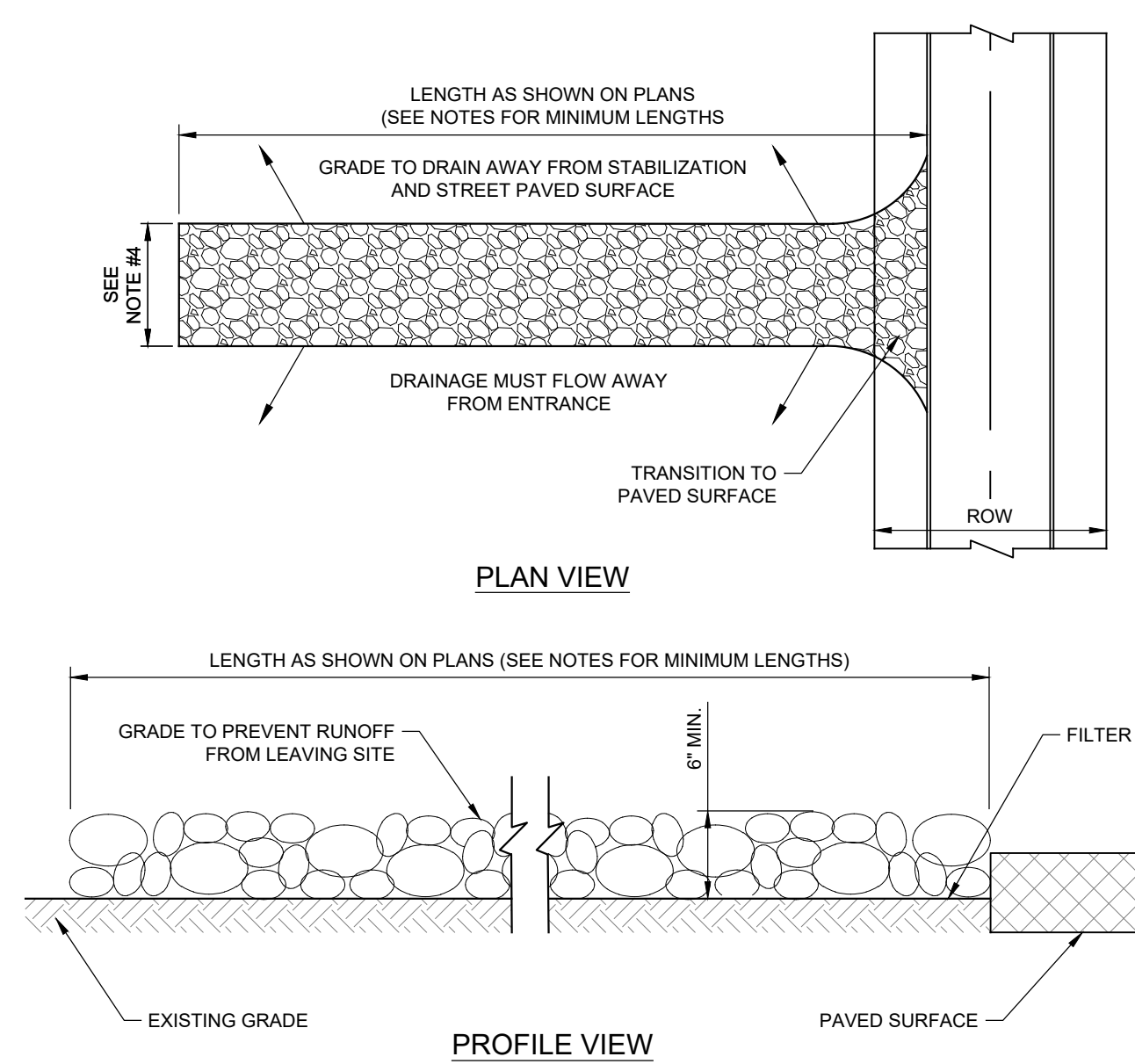

TABLE 3.9 MINIMUM EXIT DIMENSIONS

DISTURBED AREA	MIN. WIDTH OF EXIT	MIN. LENGTH OF EXIT
< 1 ACRE	15 FT	20 FT
≥ 1 ACRE BUT < 5 ACRES	25 FT	50 FT
≥ 5 ACRES	30 FT	50 FT

REVISIONS

No.	DATE	BY

Kimley-Horn

67023 KIMLEY-HORN AND ASSOCIATES, INC. 10000 RIVERSIDE DRIVE, SUITE 2100, DALLAS, TEXAS 75244-3914
 PHONE: 214-341-3868 FAX: 214-341-2669 WWW.KIMLEY-HORN.COM TYPE: PLAN NO. 928

Allen Harrison Co.

9/5/2023

SCALE: AS SHOWN

DESIGNED BY: ACN

DRAWN BY: MAB

CHECKED BY: AKP

EROSION CONTROL DETAILS

LEMON CREEK RANCH MULTI-FAMILY PREPARED FOR ALLEN HARRISON CO. SAN ANTONIO, TX.

811 Know what's below. Call before you dig.

CAUTION! EXISTING UNDERGROUND UTILITIES IN THE AREA CONTRACTOR IS RESPONSIBLE FOR DETERMINING THE HORIZONTAL AND VERTICAL LOCATION OF ALL UTILITIES PRIOR TO CONSTRUCTION. CONTRACTOR SHALL BE RESPONSIBLE FOR ANY REPAIRS TO EXISTING UTILITIES DUE TO DAMAGE INCURRED DURING CONSTRUCTION. CONTRACTOR SHALL NOTIFY THE ENGINEER OF ANY DISCREPANCIES ON THE PLANS.

SHEET NUMBER **C-1.2**

Plotted By: Galena, Sebastian, September 05, 2023 04:39:03pm. K:\SNA_CIV\067808807-LCR MF - Allen Harrison Co\CAD\PlanSheets\C-EROS-067808807-LCR MF - Allen Harrison Co\CAD\PlanSheets\C-EROS-067808807.dwg. This document, together with the concepts and designs presented herein, is an instrument of service, as defined only for the specific purpose and client for which it was prepared. Reuse of said engineer's reliance on this document without written authorization and deposition by Kimley-Horn and Associates, Inc. shall be without liability to Kimley-Horn and Associates, Inc.

APPENDIX B

CONSTRUCTION ACTIVITY SCHEDULE

Construction Activity Schedule

Activities	Start Date	Finish Date
1.		
2.		
3.		
4.		
5.		
6.		
7.		
8.		
9.		
10.		
11.		

*Construction activity sequences for linear projects may be conducted on a rolling basis. As a result, construction activities may be at different stages at different locations in the project area. The Contractor is required to complete and update the schedule and adjust as necessary.

APPENDIX C

BEST MANAGEMENT PRACTICE MEASURES AND CONTROLS

Best Management Practice Measures and Controls

Best Management Practice (BMP)	In Use	Maintained Post Construction?
Interceptor Swale	x	x
Diversion Dike		
Pipe Slope Drain		
Vegetation	x	x
Mulching		
Erosion Control Blankets		
Channel Protection	x	
Dust Control		
Silt Fence	x	
Organic Filter Berm		
Triangular Sediment Filter Dike		
Inlet Protection	x	
Stone Outlet Sediment Trap		
Sediment Basin		
Check Dam		
Temporary Sediment Tank		
Stabilized Construction Entrance	x	
Wheel Wash		
Debris and Trash Management	x	x
Chemical Management		
Concrete Waste Management	x	
Concrete Sawcutting Waste Management		
Sandblasting Waste Management		
Lime Stabilization Management	x	
Sanitary Facilities	x	
Other*		
Other*		

*If another BMP is being used, include the BMP information in Appendix D.

APPENDIX D

BEST MANAGEMENT PRACTICE CHECKLIST AND FACT SHEETS

EROSION AND SEDIMENT CONTROL CHECKLIST

Instructions: Check each item and fill in the blanks below to evaluate compliance for each drainage area and location.

Stabilization Practices:

- Stabilization will be initiated on all disturbed areas where construction activity will not occur for a period of more than 21 calendar days by the 14th day after construction activity has permanently or temporarily ceased. Stabilization measures to be used include:
- | | |
|--|--|
| <input type="checkbox"/> Temporary Seeding | <input type="checkbox"/> Sod Stabilization |
| <input type="checkbox"/> Permanent Seeding | <input type="checkbox"/> Geotextiles |
| <input type="checkbox"/> Mulching | <input type="checkbox"/> Other _____ |

Structural Practices

- Flows from upstream areas will be diverted from exposed soils to the degree attainable. Measures to be used include:
- Earth Dike
 - Drainage Swale
 - Interceptor Dike and Swale
 - Pipe Slope Drain
 - Other _____

For Drainage locations serving less than 10 disturbed acres, Sediment Basin will be installed and will include:

- Sediment Trap
- Silt Fence or equivalent along all sideslopes & downstream boundaries

For Drainage locations serving 10 or more disturbed acres, a Sediment Basin will be installed (See Appendix N), if a Sediment Basin is not attainable on-site, Sediment Controls will be installed & will include:

- Sediment Trap
- Silt Fence or equivalent along all sideslopes & downstream boundaries
- Sediment Basin

FINAL STABILIZATION / TERMINATION CHECKLIST

1. All soil disturbing activities are complete.
2. Temporary erosion and sediment control measures have been, or will be, removed at an appropriate time.
3. All areas of the construction site not otherwise covered by a permanent pavement or structure have been stabilized with a uniform perennial vegetative cover with a density of 70% or equivalent measures have been employed.

2.0 Erosion Controls

2.1 Check Dam

Erosion Control

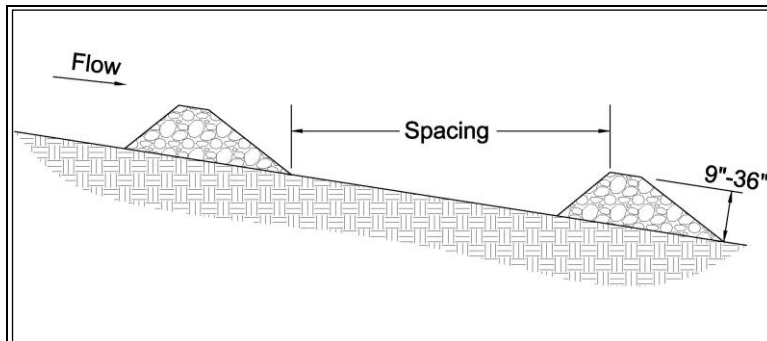

Description: Check dams are small barriers consisting of loose rock, rock bags, or organic filter tubes placed across a drainage swale or ditch. They reduce the velocity of small concentrated flows, provide a limited barrier for sediment and reduce the potential for erosion of the swale or ditch.

KEY CONSIDERATIONS

DESIGN CRITERIA:

- Heights between 9 inches and 36 inches
- Top of the downstream dam should be at the same elevation as the toe of the upstream dam

ADVANTAGES / BENEFITS:

- Reduced velocities in long drainage swales or ditches
- May be used with other channel protection measures
- Provides some sediment removal

DISADVANTAGES / LIMITATIONS:

- Cannot be used in live stream channels
- Minor ponding upstream of the check dams
- Extensive maintenance or replacement of the dams required after heavy flows or high velocity flows
- Mowing hazard from loose rocks if all rock is not removed at end of construction

MAINTENANCE REQUIREMENTS:

- Inspect regularly
- Remove silt when it reaches approximately 1/3 the height of the dam or 12 inches, whichever is less

TARGETED POLLUTANTS

- Sediment
- Nutrients & Toxic Materials
- Oil & Grease
- Floatable Materials
- Other Construction Wastes

APPLICATIONS

Perimeter Control

Slope Protection

Sediment Barrier

Channel Protection

Temporary Stabilization

Final Stabilization

Waste Management

Housekeeping Practices

Fe=0.30-0.50

(Depends on soil type)

IMPLEMENTATION CONSIDERATIONS

- Capital Costs
- Maintenance
- Training
- Suitability for Slopes > 5%

Other Considerations:

- None

2.1.1 Primary Use

Check dams are used in long drainage swales or ditches to reduce erosive velocities. They are typically used in conjunction with other channel protection techniques such as vegetation lining and turf reinforcement mats. Check dams provide limited treatment to sediment-laden flows. They are more useful in reducing flow velocities to acceptable levels for stabilization methods. Check dams may be used in combination with stone outlet sediment traps, where the check dams prevent erosion of the swale while the sediment trap captures sediment at the downstream end of the swale.

2.1.2 Applications

Check dams are typically used in swales and drainage ditches along linear projects such as roadways. They can also be used in short swales down a steep slope, such as swales down a highway embankment, to reduce velocities. Check dams shall not be used in live stream channels.

Check dams should be installed before the contributing drainage area is disturbed, so as to mitigate the effects on the swale from the increase in runoff. If the swale itself is graded as part of the construction activities, check dams are installed immediately upon completion of grading to control velocities in the swale until stabilization is completed.

2.1.3 Design Criteria

General Criteria

- Typically, the dam height should be between 9 inches and 36 inches, depending on the material of which they are made. The height of the check dam shall always be less than one-third the depth of the channel.
- Dams should be spaced such that the top of the downstream dam is at the same elevation as the toe of the upstream dam. On channel grades flatter than 0.4 percent, check dams should be placed at a distance that allows small pools to form between each check dam.
- The top of the side of the check dam shall be a minimum of 12 inches higher than the middle of the dam. In addition, the side of the dams shall be embedded a minimum of 18 inches into the side of the drainage ditch, swale or channel to minimize the potential for flows to erode around the side of the dam.
- Larger flows (greater than 2-year, 24-hour design storm) must pass the check dam without causing excessive upstream flooding.
- Check dams should be used in conjunction with other sediment reduction techniques prior to releasing flow offsite.
- Use geotextile filter fabric under check dams of 12 inches in height or greater. The fabric shall meet the following minimum criteria:
 - Tensile Strength, ASTM D4632 Test Method for Grab Breaking Load and Elongation of Geotextiles, 250-lbs.
 - Puncture Rating, ASTM D4833 Test Method for Index Puncture Resistance of Geotextiles, Geomembranes, and Related Products, 135-lbs.
 - Mullen Burst Rating, ASTM D3786 Standard Test Method for Hydraulic Bursting Strength of Textile Fabrics-Diaphragm Bursting Strength Tester Method, 420-psi.
 - Apparent Opening Size, ASTM D4751 Test Method for Determining Apparent Opening Size of a Geotextile, U.S. Sieve No. 20 (max).
- Loose, unconfined soil, wood chips, compost, and other material that can float or be transported by runoff shall not be used to construct check dams.

Rock Check Dams

- Stone shall be well graded with stone size ranging from 3 to 6 inches in diameter for a check dam height of 24 inches or less. The stone size range for check dams greater than 24 inches is 4 to 8 inches in diameter.
- Rock check dams shall have a minimum top width of 2 feet with side slopes of 2:1 or flatter.

Rock Bag Check Dams

- Rock bag check dams should have a minimum top width of 16 inches.
- Bag length shall be 24 inches to 30 inches, width shall be 16 inches to 18 inches and thickness shall be 6 inches to 8 inches and having a minimum weight of 40 pounds.
- Minimum rock bag dam height of 12 inches would consist of one row of bags stacked on top of two rows of bag. The dam shall always be one more row wide than it is high, stacked pyramid fashion.
- Bags should be filled with pea gravel, filter stone, or aggregate that is clean and free of deleterious material.
- Sand bags shall not be used for check dams, due to their propensity to break and release sand that is transported by the concentrated flow in the drainage swale or ditch.
- Bag material shall be polypropylene, polyethylene, polyamide or cotton burlap woven fabric, minimum unit weight 4-ounces-per-square-yard, Mullen burst strength exceeding 300-psi as determined by ASTM D3786, Standard Test Method for Hydraulic Bursting Strength of Textile Fabrics-Diaphragm Bursting Strength Tester Method, and ultraviolet stability exceeding 70 percent.
- PVC pipes may be installed through the dam to allow for controlled flow through the dam. Pipe should be schedule 40 or heavier polyvinyl chloride (PVC) having a nominal internal diameter of 2 inches.

Sack Gabion Check Dams

- Sack gabion check dams may be used in channels with a contributing drainage area of 5 acres or less.
- Sack gabions shall be wrapped in galvanized steel, woven wire mesh. The wire shall be 20 gauge with 1 inch diameter, hexagonal openings.
- Wire mesh shall be one piece, wrapped around the rock, and secured to itself on the downstream side using wire ties or hog rings.
- Sack gabions shall be staked with $\frac{3}{4}$ inch rebar at a maximum spacing of three feet. Each wire sack shall have a minimum of two stakes.
- Stone shall be well graded with a minimum size range from 3 to 6 inches in diameter.

Organic Filter Tube Check Dams

- Organic filter tubes may be used as check dams in channels with a contributing drainage area of 5 acres or less.
- Organic filter tubes shall be a minimum of 12 inches in diameter.
- Filter material used within tubes to construct check dams shall be limited to coir, straw, aspen fiber and other organic material with high cellulose content. The material should be slow to decay or leach nutrients in standing water.
- Staking of filter tubes shall be at a maximum of 4 foot spacing and shall alternate through the tube and on the downstream face of the tube.
- Unless superseded by requirements in this section, filter tubes and filter material shall comply with the

criteria in *Section 3.6 Organic Filter Tubes*.

2.1.4 *Design Guidance and Specifications*

Specifications for construction of this item may be found in the Standard Specifications for Public Works Construction – North Central Texas Council of Governments, Section 201.9 Check Dam (Rock). Specifications are also available in the Standard Specifications for Construction and Maintenance of Highways, Streets, and Bridges (TxDOT 2004), Item 506.2.A and Item 506.4.C.1.

2.1.5 *Inspection and Maintenance Requirements*

Check dams should be inspected regularly (at least as often as required by the TPDES Construction General Permit). Silt must be removed when it reaches approximately 1/3 the height of the dam or 12 inches, whichever is less. Inspectors should monitor the edges of the dam where it meets the sides of the drainage ditch, swale or channel for evidence of erosion due to bypass or high flows. Eroded areas shall be repaired. If erosion continues to be a problem, modifications to the check dam or additional controls are needed.

Care must be used when taking out rock check dams in order to remove as much rock as possible. Loose rock can create an extreme hazard during mowing operations once the area has been stabilized.

2.1.6 *Example Schematics*

The following schematics are example applications of the construction control. They are intended to assist in understanding the control's design and function.

The schematics are **not for construction**. They may serve as a starting point for creating a construction detail, but they must be adapted for the site by the designer. Dimensions and notes appropriate for the application must also be added by the designer.

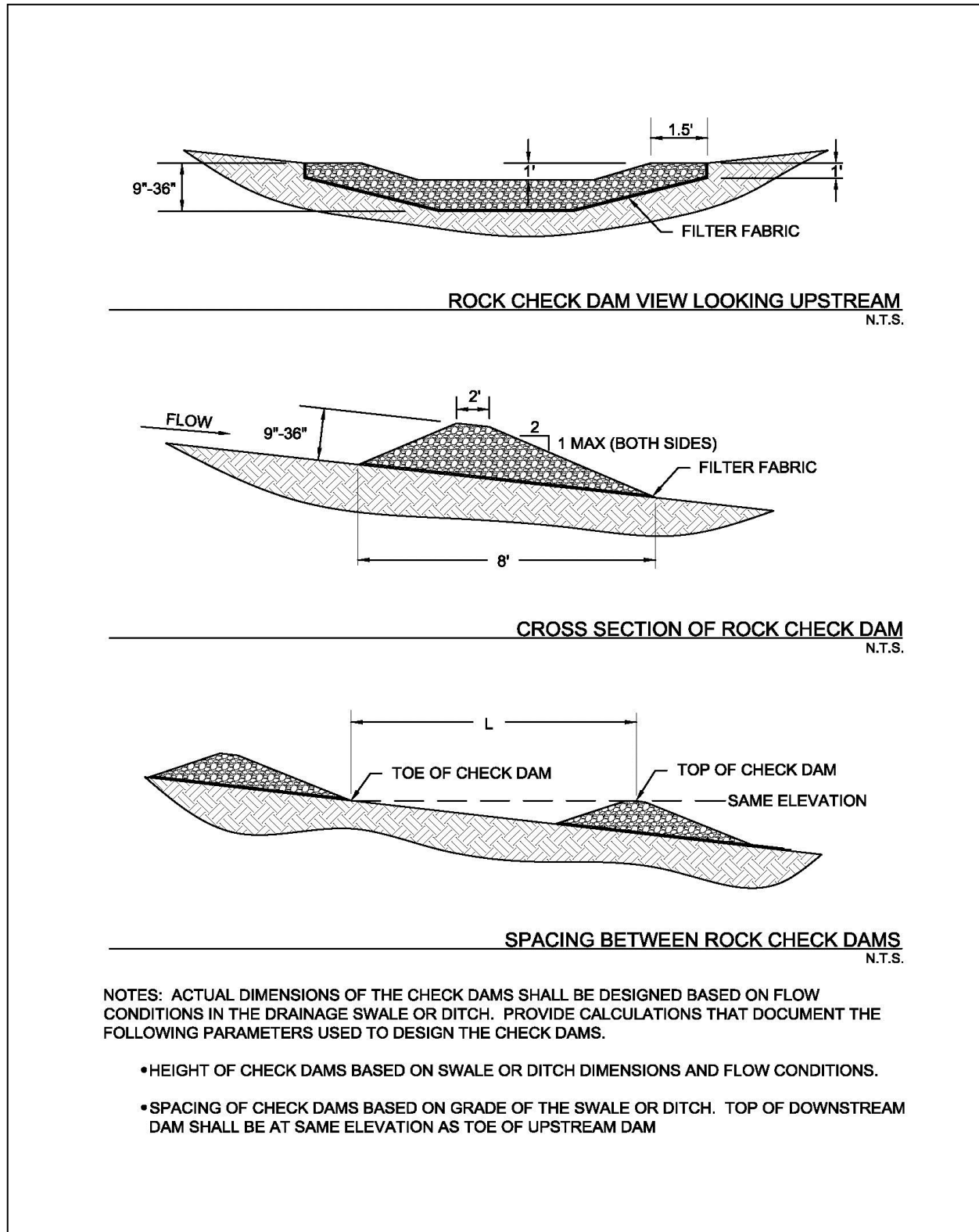

Figure 2.1 Schematics of Rock Check Dams

(Source: Modified from Stormwater Management Manual for Western Washington)

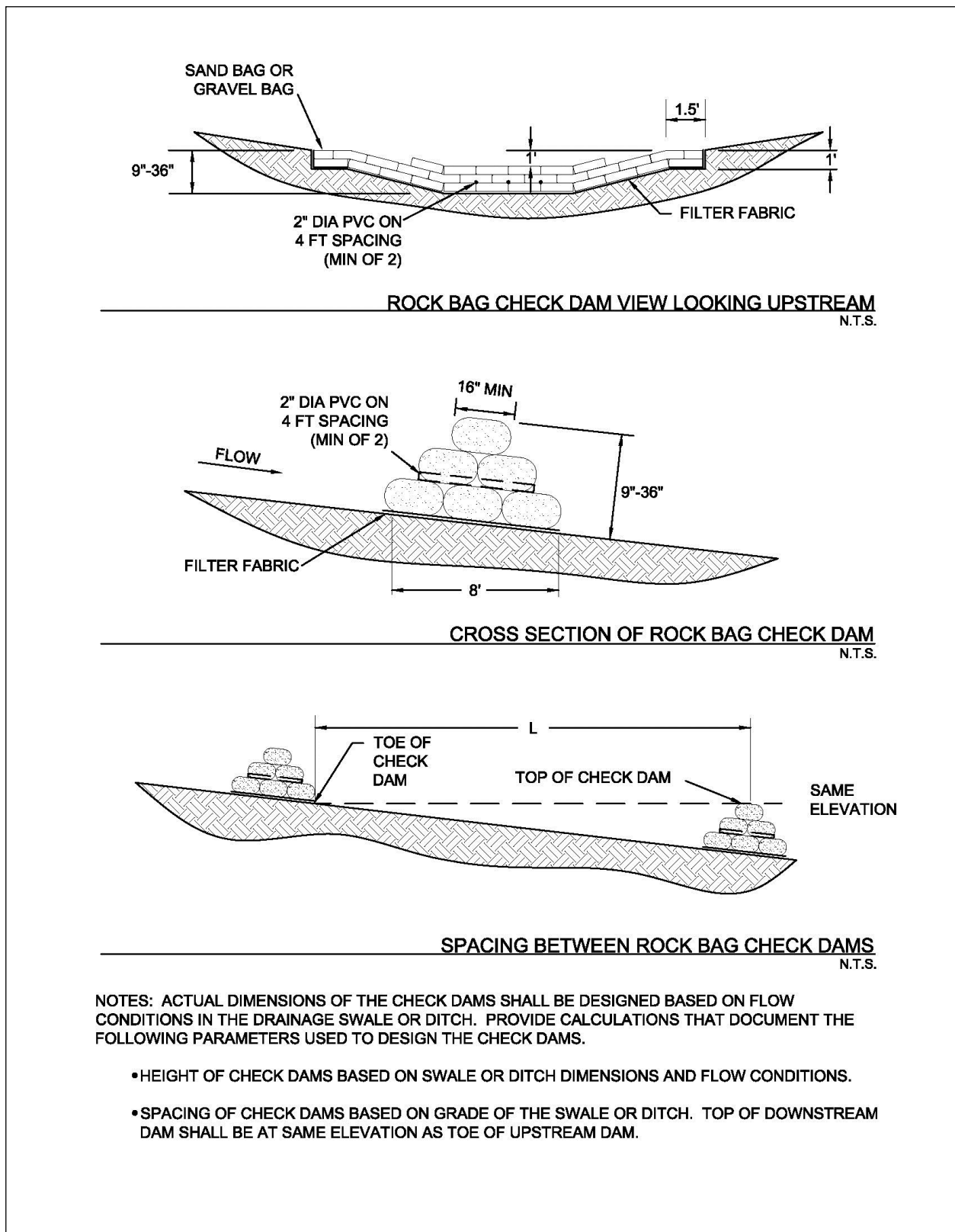
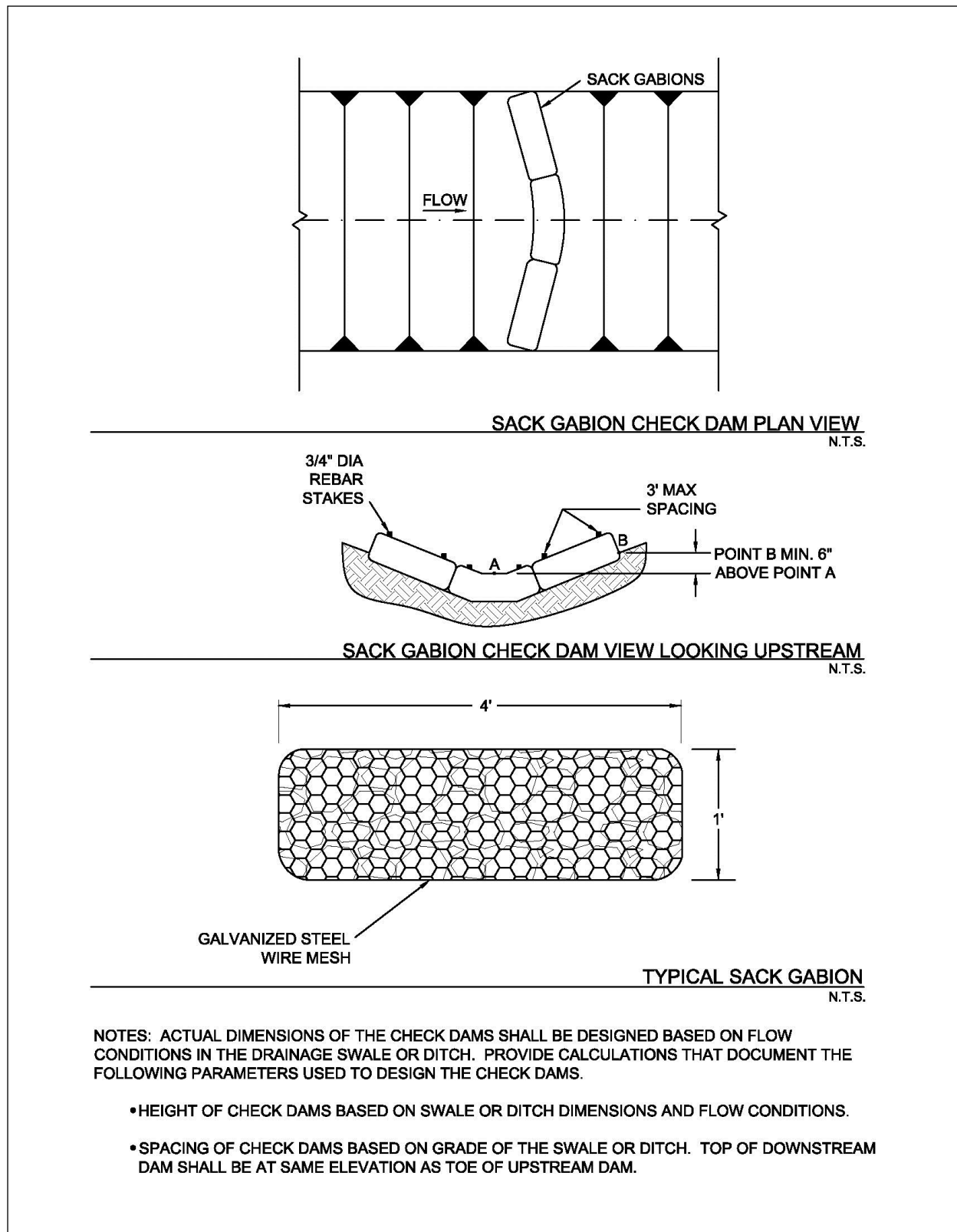

Figure 2.2 Schematics of Rock Bag Check Dams



NOTES: ACTUAL DIMENSIONS OF THE CHECK DAMS SHALL BE DESIGNED BASED ON FLOW CONDITIONS IN THE DRAINAGE SWALE OR DITCH. PROVIDE CALCULATIONS THAT DOCUMENT THE FOLLOWING PARAMETERS USED TO DESIGN THE CHECK DAMS.

- HEIGHT OF CHECK DAMS BASED ON SWALE OR DITCH DIMENSIONS AND FLOW CONDITIONS.
- SPACING OF CHECK DAMS BASED ON GRADE OF THE SWALE OR DITCH. TOP OF DOWNSTREAM DAM SHALL BE AT SAME ELEVATION AS TOE OF UPSTREAM DAM.

Figure 2.3 Schematics of Sack Gabion Check Dams
 (Source: Modified from Texas Department of Transportation Detail Sheet EC (2)-93)

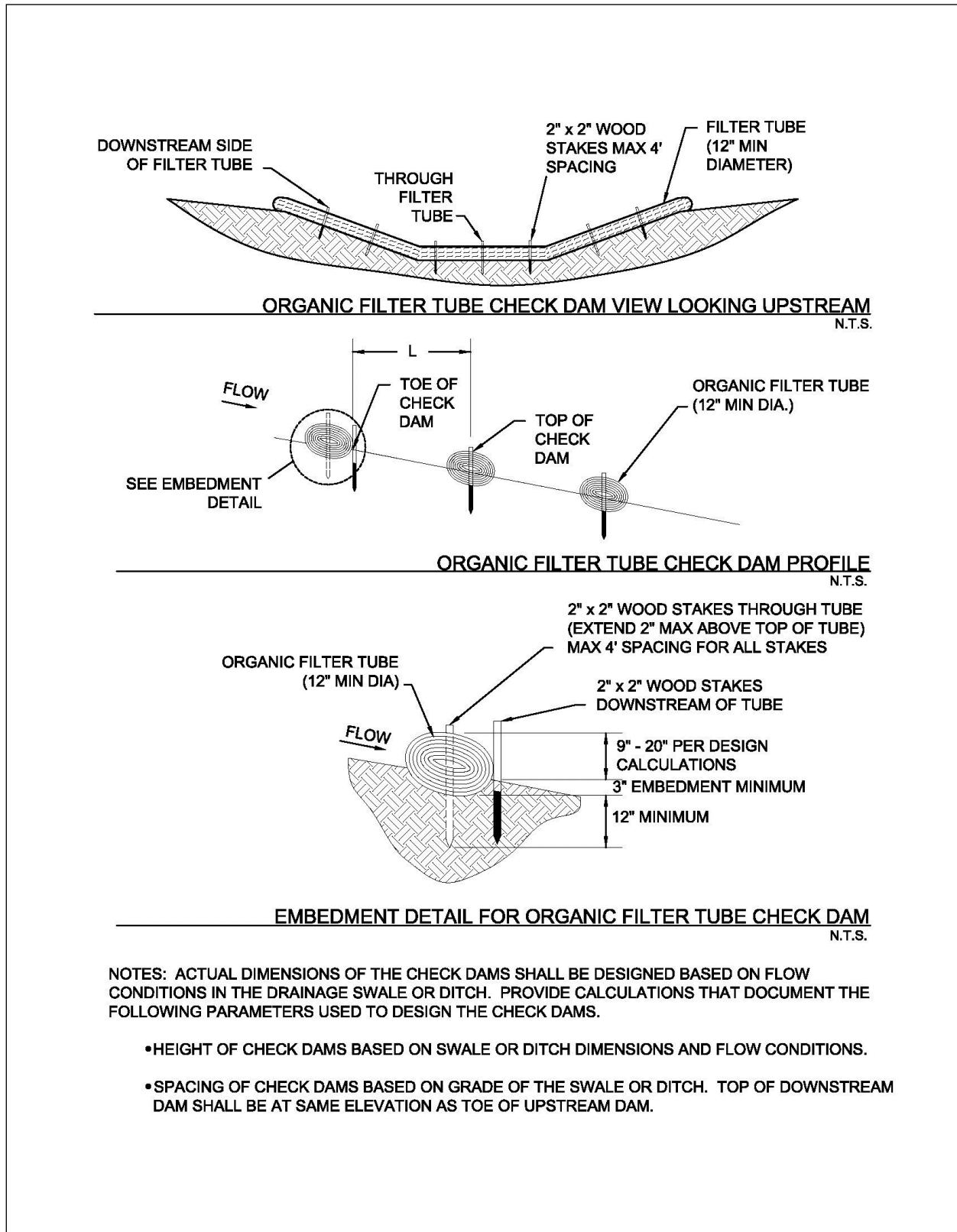
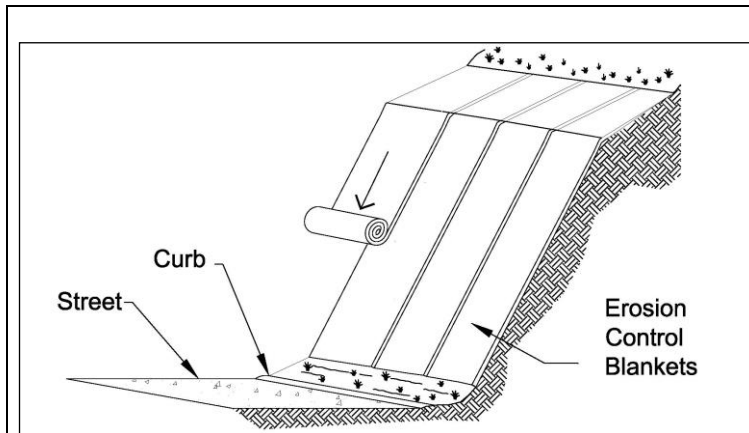

Figure 2.4 Schematics of Organic Filter Tube Check Dams

(Source: Modified from City of Plano BMP S-7)

2.3 Erosion Control Blankets

Erosion Control



Description: An erosion control blanket (ECB) is a temporary, degradable, rolled erosion control product that reduces soil erosion and assists in the establishment and growth of vegetation. ECBs, also known as soil retention blankets, are manufactured by many companies and are composed primarily of processed, natural, organic materials that are woven, glued, or structurally bound together with natural fiber netting or mesh on one or both sides.

KEY CONSIDERATIONS

DESIGN CRITERIA:

- ECB selected based on slope, flow rate and length of service
- Specify preparation of soil surface to ensure uniform contact with blanket
- Installation and anchoring according to manufacturer's recommendations

ADVANTAGES / BENEFITS:

- Holds seed and soil in place until vegetation is established
- Effective for slopes, embankments and small channels

DISADVANTAGES / LIMITATIONS:

- Not for use on slopes greater than 2:1 or in channels with shear stresses greater than 2.0 pounds per square foot

MAINTENANCE REQUIREMENTS:

- Replace or re-anchor loosened blankets
- Remove sediment deposited on blankets

TARGETED POLLUTANTS

- Sediment
- Nutrients & Toxic Materials
- Oil & Grease
- Floatable Materials
- Other Construction Waste

APPLICATIONS

Perimeter Control
Slope Protection
Sediment Barrier
Channel Protection
Temporary Stabilization
Final Stabilization

Waste Management

Housekeeping Practices

Fe=0.90 (*Ground cover*)

Fe=0.65

(*Perimeter w/o vegetation*)

IMPLEMENTATION CONSIDERATIONS

- Capital Costs
- Maintenance
- Training
- Suitability for Slopes > 5%

Other Considerations:

- *Life expectancy, partial degradation, and mowing/maintenance issues for ECBs left in place as part of final stabilization*

2.3.1 Primary Use

Erosion control blankets (ECBs) are used to hold seed and soil in place until vegetation is established on disturbed areas. They can be used on many types of disturbed areas, but are particularly effective for slopes and embankments and in small drainage swales.

ECBs seeded for vegetation may be used as a perimeter control. When used in combination with other sediment barriers, such as silt fence or organic filter tubes, blankets may be used as a perimeter control with or without vegetation.

2.3.2 Applications

ECBs may be used on many types of disturbed areas but are most applicable on gradual to steep (2:1) cut/fill slopes and in swales and channels with low to moderate flow velocities. In these applications they may provide temporary stabilization by themselves or may be used with seeding to provide final stabilization. ECBs are also used to establish vegetation in channels where velocities are less than 6.0 feet per second.

When seeded for establishment of vegetation, ECBs can be an effective perimeter along the down slope side of linear construction projects (roads and utilities). ECBs with vegetation are also used as perimeter controls for new development, particularly at the front on residential lots in new subdivisions. ECBs are an effective aid in establishing vegetated filter strips.

2.3.3 Design Criteria

- The designer shall specify the manufacturer, type of erosion control blanket to be used, and dimensioned limits of installation based on the site topography and drainage.
- The type and class of erosion control blanket must be specified in accordance with the manufacturer's guidance for the slope of the area to be protected, the flow rate (sheet flow on cut/fill slopes) or velocity (concentrated flow in swales) of stormwater runoff in contact in with the ECB, and the anticipated length of service.
- ECBs should meet the applicable "Minimum Performance Standards for TxDOT" as published by TxDOT in its "Erosion Control Report" and/or be listed on the most current annual "Approved Products List for TxDOT" applicable to TxDOT Item 169 Soil Retention Blanket and its Special Provisions.
- ECBs shall be installed vertically down slope (across contours) on cut/fill slopes and embankments and along the contours (parallel to flow) in swales and drainage ditches.
- ECBs designed to remain onsite as part of final stabilization shall have netting or mesh only on one side (the exposed side) of the ECB. The ECB shall be installed with the side that does not have netting or mesh in contact with the soil surface. All materials in the ECB, including anchors, should be 100 percent biodegradable within three years.
- On cut/fill slopes and drainage ditches or swales designed to receive erosion control blankets for temporary or final stabilization, installation of the ECBs shall be initiated immediately after completing grading of the slope or drainage way, and in no case later than 14 days after completion of grading these features. Do not delay installation of ECBs on these highly-erodible areas until completion of construction activities and stabilization of the remainder of the site.
- Unless the ECB is seeded to establish vegetation, perimeter control applications shall be limited to thirty foot wide drainage areas (i.e. linear construction projects) for an 8 foot width of ECB. When seeded for vegetation, use of ECBs for perimeter control shall follow the criteria in the [Section 3.15 Vegetated Filter Strips and Buffers](#).
- Prior to the installation of the ECB, all rocks, dirt clods, stumps, roots, trash and any other obstructions that would prevent the ECB from lying in direct contact with the soil shall be removed.

- Anchor trenching shall be located along the top of slope of the installation area, except for small areas with less than 2 percent slope.
- Installation and anchoring shall conform to the recommendations shown within the manufacturer's published literature for the erosion control blanket. Anchors (staples) shall be a minimum of 6 inches in length and 1 inch wide. They shall be made of 11-gauge wire, or equivalent, unless the ECB is intended to remain in place with final stabilization and biodegrade.
- Particular attention must be paid to joints and overlapping material. Overlap along the sides and at the ends of ECBs should be per the manufacturer's recommendations for site conditions and the type of ECB being installed. At a minimum, the end of each roll of ECB shall overlap the next roll by 3 feet and the sides of rolls shall overlap 4 inches.
- After installation, the blankets should be checked for uniform contact with the soil, security of the lap joints, and flushness of the staples with the ground.
- When ECBs are installed to assist with establishing vegetation, seeding shall be completed before installation of the ECB. Criteria for seeding are provided in [Section 2.9 Vegetation](#).
- Turf Reinforcement Mats should be used instead of ECBs for permanent erosion control and for stabilizing slopes greater than 2:1.
- ECBs are limited to use in swales and channels that have shear stresses of less than 2.0 pounds per square foot. Turf reinforcement mats shall be used in open channels with higher shear stresses.

2.3.4 Design Guidance and Specifications

Specifications for construction of this item may be found in the Standard Specifications for Public Works Construction – North Central Texas Council of Governments, Section 201.15 Erosion Control Blankets and in Item 169 of the Standard Specifications for Construction and Maintenance of Highways, Streets, and Bridges (TxDOT, 2004).

2.3.5 Inspection and Maintenance Requirements

Erosion control blankets should be inspected regularly (at least as often as required by the TPDES Construction General Permit) for bare spots caused by weather or other events. Missing or loosened blankets must be replaced or re-anchored.

Check for excess sediment deposited from runoff. Remove sediment and/or replace blanket as necessary. In addition, determine the source of excess sediment and implement appropriate measures to control the erosion. Also check for rill erosion developing under the blankets. If found, repair the eroded area. Determine the source of water causing the erosion and add controls to prevent its reoccurrence.

2.3.6 Example Schematics

The following schematics are example applications of the construction control. They are intended to assist in understanding the control's design and function.

The schematics are **not for construction**. The designer is responsible for working with ECB manufacturers to ensure the proper ECB is specified based on the site topography and drainage. Installation measures should be dictated by the ECB manufacturer and are dependent on the type of ECB installed. Manufacturer's recommendations for overlap, anchoring, and stapling shall always be followed. Criteria shown here are applicable only when they are more stringent than those provided by the manufacturer.

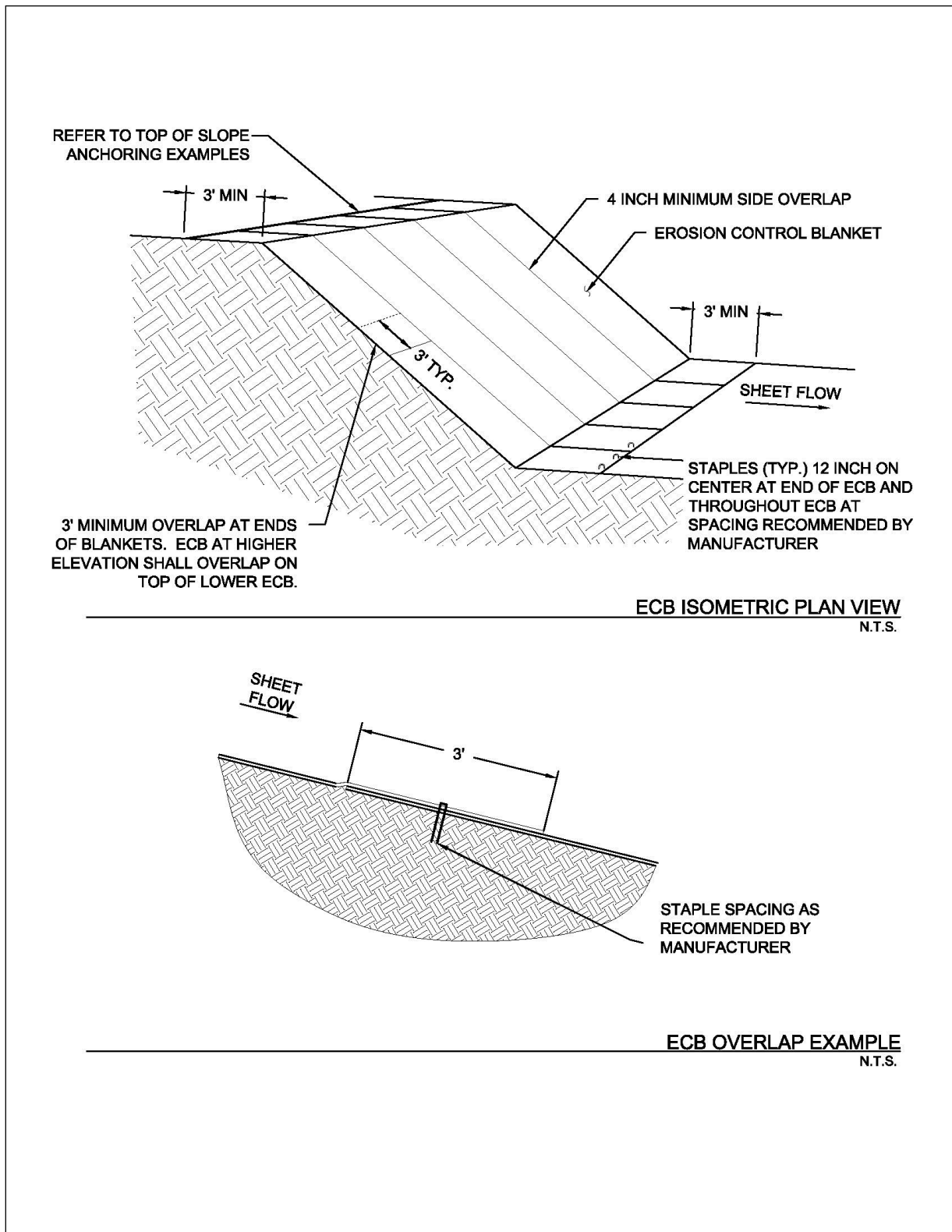

Figure 2.7 Schematics of Erosion Control Blankets

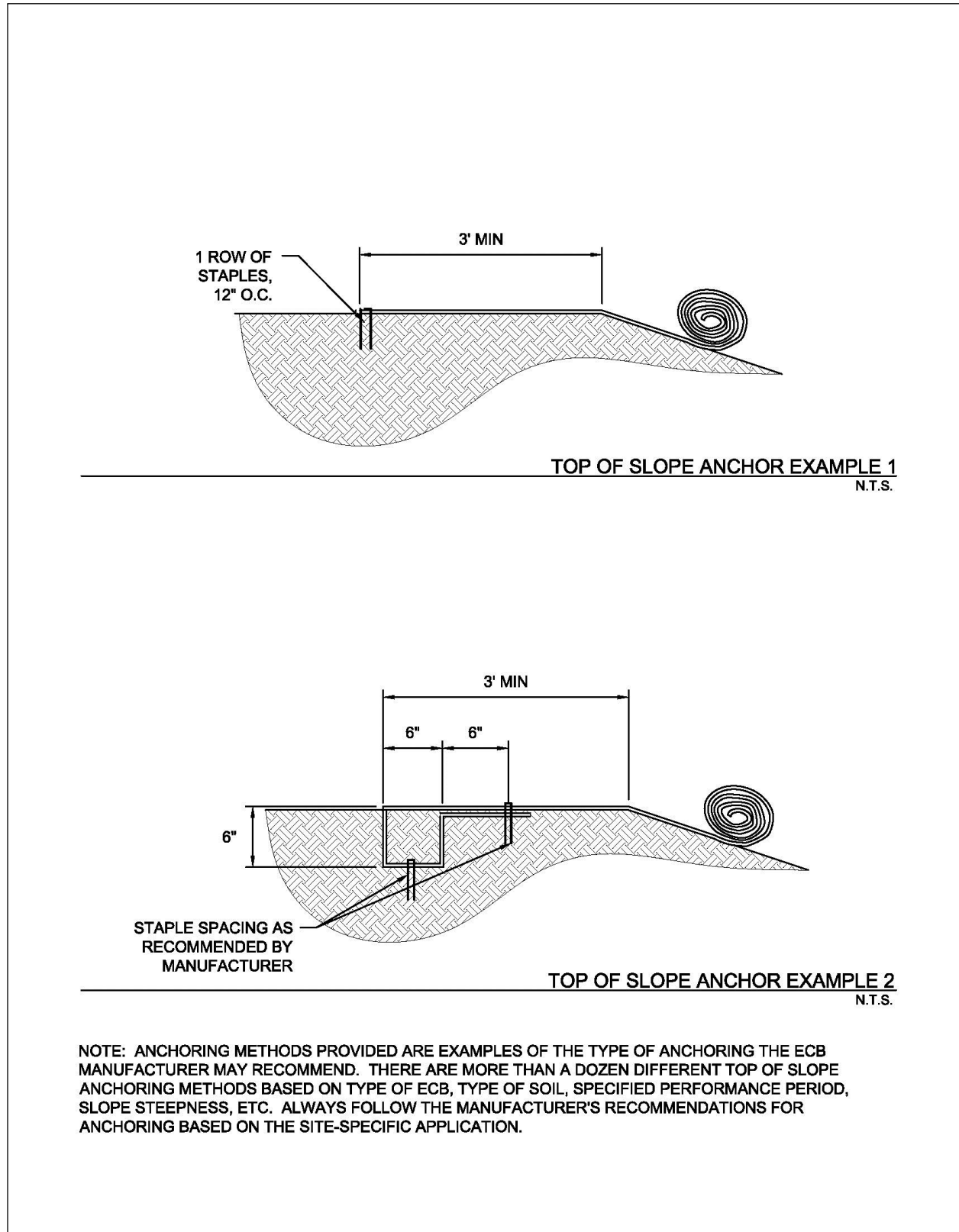
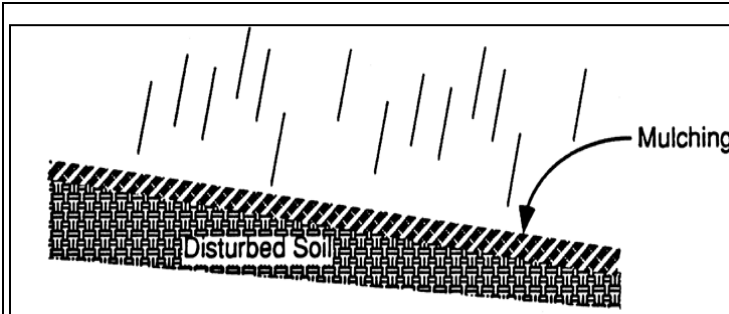

Figure 2.8 Anchor Examples for Erosion Control Blankets

(Sources: American Excelsior Company and Western Excelsior Corporation)

2.5 Mulching

Erosion Control



Description: Mulching is the application of a uniform layer of organic material over barren areas to reduce the effects of erosion from rainfall. Types of mulch include compost mixtures, straw, wood chips, bark, or other fibers. Commercialized surface treatments that combine straw or other mulch material with organic or inorganic soil binding systems are also available and are particularly useful on steep slopes.

KEY CONSIDERATIONS

DESIGN CRITERIA:

- Specify even, uniform application
- Thickness of 1 to 2 inches, depending on application
- Application criteria specific to type of mulch
- Anchor mulch on slopes of 3:1 to 1.5:1
- Do not use mulch on slopes steeper than 1.5:1

ADVANTAGES / BENEFITS:

- Provides immediate stabilization of bare areas
- May be used with seeding for final stabilization
- Decreases soil moisture loss
- Decreases velocity of sheet flow
- Reduces volume of sediment-laden flow

DISADVANTAGES / LIMITATIONS:

- Subject to removal by wind or water
- Results in lower soil temperature, which may yield longer seed germination periods
- Should not be applied within the ordinary high-water mark of natural surface waters or within the design flow depth of constructed ditches and channels

MAINTENANCE REQUIREMENTS:

- Inspect regularly
- Replace regularly in high traffic areas to maintain uniform thickness
- Maintain a stockpile of excess mulch at the site to repair problem spots

TARGETED POLLUTANTS

- Sediment
- Nutrients & Toxic Materials
- Oil & Grease
- Floatable Materials
- Other Construction Wastes

APPLICATIONS

Perimeter Control

Slope Protection

Sediment Barrier

Channel Protection

Temporary Stabilization

Final Stabilization

Waste Management

Housekeeping Practices

Fe=0.75-0.90

(Depends on coverage)

IMPLEMENTATION CONSIDERATIONS

- Capital Costs
- Maintenance
- Training
- Suitability for Slopes > 5%

Other Considerations:

- Availability of materials for mulch
- Application depends on slope

2.5.1 Primary Use

Mulch may be used by itself to temporarily stabilize bare areas or with seed to establish final stabilization of bare areas. Mulch protects the soil from erosion and moisture loss by lessening the effects of wind, water, and sunlight. It also decreases the velocity of sheet flow, thereby reducing the volume of sediment-laden water flow leaving the mulched area.

2.5.2 Applications

Mulch may be applied on most areas disturbed by construction that require surface protection including:

- Freshly seeded or planted areas;
- Disturbed areas at risk of erosion due to the time period being unsuitable for growing vegetation;
- Disturbed areas that are not conducive to vegetation for temporary stabilization; or
- Steep slopes of 3:1 to 1.5:1, provided the mulch is anchored to the soil by use of soil stabilizers, netting, or crimping.

Mulch is frequently applied with seeding for vegetation. In these cases, refer to [Section 2.9 Vegetation](#) for related criteria that may affect mulching.

Mulch may also be applied with commercially available polymers for soil surface treatment to bind the mulch with the soil. This method is particularly useful on steep slopes. Related criteria are available in [Section 2.7 Soil Surface Treatments](#).

2.5.3 Design Criteria

General

- Specific design information is required for the use of this control. The designer shall specify the type of mulch to be used, the application rate and/or thickness, and the type of anchoring (if applicable) based on site conditions.
- Choice of mulch depends largely on slope and soil type, in addition to availability of materials.
- Netting, adhesive polymers, or other methods of anchoring the mulch are required on slopes of 3:1 to 1.5:1. Do not use mulch on slopes steeper than 1.5:1.
- Mulch should be applied in an even and uniform manner where concentrated water flow is negligible. Do not apply mulch within the ordinary high-water mark of natural surface waters or within the design flow depth of constructed ditches and channels.
- Hay should not be used as mulch.
- Organic mulches may be distributed by hand or by mechanical means, provided a uniform thickness is achieved.
- When mulch is used with vegetation for final stabilization, fertilization and soil treatment for vegetation establishment should be done prior to placement of mulch, with the exception of hydroseeding or when seed is distributed following straw mulch spread during winter months.
- Table 2.1 on the following page contains a summary of mulch types and general guidelines.

Mulch Material	Quality Standards	Application Rates	Remarks
Straw	Air-dried, free of mold and not rotten. Certified Weed Free.	1.5 to 2 tons per acre	Cost-effective when applied with adequate thickness. Straw must be held in place by crimping, netting, or soil stabilizer.
Chipped Site Vegetation	Should include gradation from fine to coarse to promote interlocking properties. Must be free of waste materials such as plastic bags, metal debris, etc.	10 to 12 tons per acre	Cost-effective method to dispose of vegetative debris from site. Best application is for temporary stabilization where construction will resume. Use cautiously on areas where vegetation will be established, as wood chips will deplete soil nitrogen.
Erosion Control Compost (Wood Chip and Compost Mixture)	Shall meet the Physical Requirements in Table 1 of TxDOT Special Specification 1001.	Approx. 10 tons per acre	Special caution is advised regarding the source and composition of wood mulches. Ensure compost is free of herbicides. Ensure wood chips are from unpainted and untreated wood.
Hydraulic Mulch	Must not contain sawdust, cardboard, paper, paper byproducts, plastics, or synthetics. No petroleum-based tackifiers.	Follow the manufacturer's recommendations. Application rate increases with slope steepness.	May be particularly effective on slopes steeper than 3:1. Ensure wood fibers are from unpainted and untreated wood.

Straw Mulch

- Straw mulch shall be free of weed and grass seed.
- Straw mulch shall be air-dried, free of mold, and not rotten.
- Straw fibers shall be a minimum of 4 inches and a maximum of 8 inches in length.
- Straw mulch must be anchored by using a tractor-drawn crimper to punch into the soil, by placing degradable netting above the mulch, or by application of a soil stabilizer (*Section 2.7 Soil Surface Treatments*).

Chipped Site Vegetation

- Chipped site vegetation is suitable mulch for temporary stabilization before construction will resume in an area of the construction site.
- Ensure the cleared vegetation is free of trash, litter, and debris prior to chipping.

- Chipped pieces shall be a minimum of 2 inches and a maximum of 6 inches in length.
- Chipped woody vegetation that is greater than 50% wood chips by volume may result in mulch that depletes nitrogen in the soil. It is useful as mulch for temporary stabilization where construction activity will resume and result in removal of the mulch. However, it should be used with care on areas where vegetation will be established for final stabilization.
- Chipped vegetation that is greater than 50 percent wood chips by volume may require treatment with a nitrogen fertilizer when used for mulch with seeding.
- Chipped vegetation that includes green matter will include seeds. It should not be used on areas that have specific landscaping requirements.

Erosion Control Compost (Wood Chip and Compost Mixture)

- Wood chip and compost mixture used for mulch shall meet the criteria for Erosion Control Compost in TxDOT Special Specification 1001.
- Wood chips for the mixture shall be less than or equal to 5 inches in length with 95 percent passing a 2 inch screen and less than 30 percent passing a 1 inch screen. Mulch should not contain chipped manufactured boards or chemically treated wood such as particleboard, railroad ties, or similar treated wood.
- Compost for the mixture shall meet the Physical Requirements specified in Table 1 of 2004 TxDOT Special Specification 1001, Compost. It must be free of herbicides and other chemicals.
- Mixing of the Erosion Control Compost into the soil surface is allowed when vegetation is established for final stabilization, except for drill seeding, in which case it is best to leave the mulch as an undisturbed top layer.

Hydraulic Mulch (Including Bonded Fiber Matrix)

- Hydraulic mulch shall consist of a mixture of shredded wood fiber and a stabilizing binder. The mulch must not contain sawdust, cardboard, paper or paper byproducts.
- Shredded wood fiber shall be long strand, whole wood fibers that are:
 - Minimum of 25 percent of fibers 3/8 inch long;
 - Minimum of 50 percent held on a No. 25 sieve;
 - Free from paint, printing ink, varnish, petroleum products, seed germination inhibitors; and
 - Free from synthetic or plastic materials.
- Mulch binders may be organic or inorganic polymers. Asphaltic emulsions and other petroleum-based tackifiers shall not be used.
- The stabilizing emulsion must be nonflammable, non-toxic to aquatic organisms, and free from growth or germination inhibiting factors.
- Areas hydraulically mulched shall be protected from all traffic, including foot traffic, a minimum of 24 hours to allow the mulch to dry and cure. Depending on the mulch, up to 48 hours of protection may be required. Always follow manufacturer's recommendations.
- Hydraulic mulch provides limited to no protection until cured. Do not apply when rain is forecast within the next 24 hours.
- Hydraulic mulch may be particularly effective on slopes steeper than 3:1.

2.5.4 Design Guidance and Specifications

Specifications for construction of this item may be found in the Standard Specifications for Public Works Construction – North Central Texas Council of Governments, Section 201.16 Mulching. Specifications for

compost may be found in Standard Specifications for Construction and Maintenance of Highways, Streets and Bridges (TxDOT 2004) Item 161.

2.5.5 Inspection and Maintenance Requirements

Mulched areas should be inspected regularly (at least as often as required by the TPDES Construction General Permit) for thin or bare spots caused by natural decomposition or weather related events. Mulch in high traffic areas should be replaced on a regular basis to maintain uniform protection. Excess mulch should be brought to the site and stockpiled for use during the maintenance period to dress problem spots.

2.9 Vegetation

Erosion Control

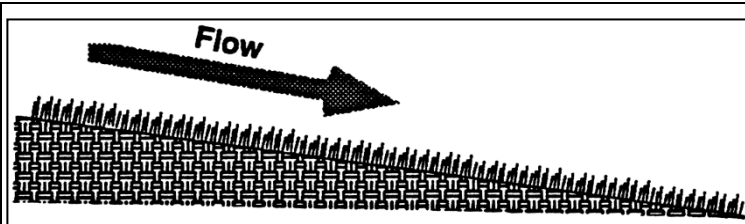

Description: Vegetation, used as an erosion control, is the sowing or sodding of grasses, small grains, or legumes to provide temporary and final vegetative stabilization for disturbed areas.

KEY CONSIDERATIONS

DESIGN CRITERIA:

- Specify preparation of the soil surface before seeding or sodding
- Minimum of 4 to 6 inches of top soil required, depending on subsurface conditions
- Specify soil amendments depending on soil conditions
- Select seed or sod species appropriate for the climate, season, and soil

ADVANTAGES / BENEFITS:

- More effective and easier to maintain than sediment controls during a long construction period
- May be used for temporary or final stabilization

DISADVANTAGES / LIMITATIONS:

- Not appropriate for areas with heavy pedestrian, vehicular traffic, or concentrated, high velocity flow
- May require days to weeks for adequate establishment
- Alternate erosion control is needed until vegetation is established

MAINTENANCE REQUIREMENTS:

- Inspect regularly
- Protect newly seeded areas from excessive runoff, high velocity flow, and traffic until vegetation is established
- Water and fertilize until vegetation is established
- Reseed and/or provide mulch or another control for bare spots
- Rake accumulations of sediment from the vegetation

TARGETED POLLUTANTS

- Sediment
- Nutrients & Toxic Materials
- Oil & Grease
- Floatable Materials
- Other Construction Wastes

APPLICATIONS

Perimeter Control

Slope Protection

Sediment Barrier

Channel Protection

Temporary Stabilization

Final Stabilization

Waste Management

Housekeeping Practices

Fe=0.90

(When fully established; lower while vegetation is first growing)

IMPLEMENTATION CONSIDERATIONS

- Capital Costs
- Maintenance
- Training
- Suitability for Slopes > 5%

Other Considerations:

- *Design is unique to soil and other conditions at each site*
- *Watering and other maintenance required until vegetation is established*

2.9.1 Primary Use

Vegetation is used as a temporary or final stabilization measure for areas disturbed by construction. As a temporary control, vegetation is used to stabilize stockpiles, earthen dikes, and barren areas that are inactive for longer than two weeks. As a final control at the end of construction, grasses and other vegetation provide good protection from erosion along with some filtering for overland runoff. Subjected to acceptable runoff velocities, vegetation can provide a positive method of long-term stormwater management as well as a visual amenity to the site.

Other control measures may be required to assist during the establishment of vegetation. These other controls include erosion control blankets, mulching, swales, and dikes to direct flow around newly seeded areas and proper grading to limit runoff velocities during construction.

2.9.2 Applications

Vegetation effectively reduces erosion in channels and swales and on stockpiles, dikes, and mild to medium slopes. Vegetative strips can provide some protection and sediment trapping when used as a perimeter control for utility and site development construction. Refer to [Section 3.15 Vegetated Filter Strips and Buffers](#) for more information.

In many cases, the initial cost of temporary seeding may be high compared to tarps or covers for stockpiles or other barren areas subject to erosion. This initial cost should be weighed with the amount of time the area is to remain inactive, since vegetation is more effective and the maintenance cost for vegetated areas is much less than most structural controls.

2.9.3 Design Criteria

General

- Vegetation is a highly effective erosion control when the vegetation is fully established. Until then, additional controls are needed. Sediment controls should not be removed from vegetated areas until the vegetation is established.
- On grades steeper than 20:1 (5 percent), anchored mulch or erosion control blankets are required to protect seeded areas until vegetation is established. Refer to [Section 2.5 Mulching](#) and [Section 2.3 Erosion Control Blankets](#) for design criteria.
- Vegetation may be used by itself for channel protection when the channel grade is less than 2 percent and the temporary control design storm (2-year, 24-hour) and the conveyance storm (25-year, 24-hour) flow velocities are less than 6 feet per second.
- If the velocity of the temporary control design storm is greater than 2 feet per second, erosion control blankets shall be used in the channel while vegetation is being established. Turf reinforcement mats are required when the velocity exceeds 6 feet per second. Refer to [Section 2.3 Erosion Control Blankets](#) and [Section 2.8 Turf Reinforcement Mats](#) for design criteria.
- Stabilization of channels with vegetation is limited to channels that have side slopes of 3:1 or flatter.
- On cut/fill slopes and channels designed to receive temporary or final vegetation, establishment of vegetation shall be initiated immediately after completing grading of the cut/fill slope or channel, and in no case later than 14 days after completion of grading on these features. It is not acceptable to delay establishing vegetation on these highly-erodible areas until completion of construction activities and stabilization of the remainder of the site.

Surface Preparation

- Unless infeasible, remove and stockpile existing topsoil at the start of grading activities. Store topsoil in a series of small stockpiles instead of one large stockpile to decrease the loss of aerobic soil micro-organisms during stockpiling.

- Interim or final grading must be completed prior to seeding or sodding.
- To minimize soil compaction of areas to be vegetated, limit vehicle and equipment traffic in these areas to the minimum necessary to accomplish grading.
- Install all necessary erosion structures such as dikes, swales, diversions, etc. prior to seeding or sodding.
- Spread stockpiled topsoil evenly over the disturbed area to be vegetated.
- Depth of topsoil shall be a minimum of 4 inches, with 6 inches required where the topsoil is over rock, gravel or otherwise unsuitable material for root growth. After spreading stockpiled topsoil, provide additional top soil as needed to achieve these depths.
- Compost Manufactured Topsoil as specified in TxDOT Special Specification 1001 may be used to achieve the specified depths or when it's infeasible to stockpile topsoil. Topsoil may also be acquired from another construction site if there is no space to stockpile the topsoil at that site.
- Topsoil shall have an organic content of 10 to 20 percent using ASTM D2974 Standard Test Methods for Moisture, Ash, and Organic Matter of Peat and Other Organic Soils.
- Topsoil that does not meet the organic content requirement shall be amended with General Use Compost as specified in TxDOT Special Specification 1001. Amendment should be three parts of topsoil to one part compost by volume thoroughly blended.
- Seed bed should be well pulverized and loosened to a minimum depth of 3 inches and then raked to have a uniform surface.
- When establishing vegetation from seed, groove or furrow slopes steeper than 3:1 on the contour line before seeding.

Plant Selection, Fertilization and Seeding

- Use only high quality, USDA certified seed.
- Use an appropriate species or species mixture adapted to the local climate, onsite soil conditions and the season as shown below, or consult with the local office of the Natural Resource Conservation Service (NRCS) or Texas AgriLife Extension Service for selection of proper species and application technique in this area.
- Seeding rate should be in accordance with the Tables 2.4, 2.5 and 2.6 as follow in this section or as recommended by the Natural Resources Conservation Service (NRCS) or Texas AgriLife Extension Service.
- Chemical fertilization is not recommended at the time of seeding, because it typically stimulates and is consumed by fast growing weeds that out-compete the slower growing grasses and legumes. If the topsoil has not been amended by compost as discussed above, an 0.5 inch layer of General Use Compost (TxDOT Special Specification 1001) is recommended as a surface treatment to protect the seed and provide slow release nutrients
- Evenly apply seed using a seed drill, cultipacker, terraseeding, or hydroseeder.
- Hydro-seeding should not be used on slopes of 5:1 or steeper unless Bonded Fiber Matrix is used.
- Seeded areas shall be thoroughly watered immediately after planting. Water shall be applied at a rate that moistens the top 6 inches of soil without causing runoff. Provide water daily for the first 14 days after seeding and thereafter as needed to aid in establishment of vegetation.
- Use appropriate mulching techniques ([Section 2.5 Mulching](#)) where necessary, especially during cold periods of the year. Mulch consisting of chipped site vegetation is discouraged, since the wood content may result in depleting nitrogen from the soil.

Sodding

- Use of sod should be limited to planned landscapes due to the relatively high water use of most types of sod grass.
- When sod is necessary to achieve immediate stabilization, buffalograss (*Buchloe dactyloides*) is recommended. Other types of sod may be used in landscaping when specified by a landscape architect for a commercial property or a homebuyer for a residential lot.
- The sod should be mowed prior to sod cutting so that the height of the grass shall not exceed 3 inches and should not be harvested or planted when its moisture condition is so excessively wet or dry that its survival shall be affected.
- Sod shall have a healthy, virile, system of dense, thickly matted roots throughout a minimum soil thickness of 0.75 inch.
- Sod shall be planted within 3 days after it is excavated.
- In areas subject to direct sunlight, pre-moisten prepared sod bed by watering immediately prior to placing sod.
- Sodded areas shall be thoroughly watered immediately after they are planted.

Temporary Vegetation

The following table lists recommended plant species for the North Central Texas region depending on the season for planting.

Season	Common Name	Pure Live Seed Rate (Lbs/Acre)
Sep 1 - Nov 30	Tall Fescue	4.5
	Western Wheat Grass	5.6
	Wheat (Red, Winter)	34.0
May 1 - Aug 31	Foxtail Millet	34.0
Feb 15 – May 31 Sep 1 – Dec 31	Annual Rye	20.0

Areas receiving temporary seeding and vegetation shall be landscaped, re-seeded or sodded with perennial species to establish final vegetation at the end of construction.

Vegetation for Final Stabilization

Sodding or seeding may be used to establish vegetation for final stabilization of areas disturbed by construction activity. The vegetation must achieve a cover that is 70 percent of the native background vegetative cover to be considered final stabilization. Sod will achieve this coverage quicker than seeding; however, sod is usually more expensive than seeding. Sod is most cost-effective for small areas or areas of concentrated flow or heavy pedestrian traffic where it will be difficult to establish vegetation by seeding.

Grass seed for establishing final stabilization can be sown at the same time as seeding for temporary (annual) vegetation. Drought tolerant native vegetation is recommended rather than exotics as a long-term water conservation measure. Native grasses can be planted as seed or placed as sod. Buffalo 609, for example, is a hybrid grass that is placed as sod. Fertilizers are not normally used to establish native grasses, but mulching is effective in retaining soil moisture for the native plants.

County	Planting Date	Clay Soils		Sandy Soils	
		Species and Pure Live Seed Rate (Lbs/Acre)		Species and Pure Live Seed Rate (Lbs/Acre)	
Erath Hood Johnson Palo Pinto Parker Somervell Tarrant Wise	February 1 – May 15	Green Sprangletop Sideoats Grama (El Reno) Bermudagrass Little Bluestem (Native) Blue Grama (Hachita) Illinois Bundleflower	0.3 2.7 0.9 1.0 0.9 1.0	Green Sprangletop Sand Lovegrass Bermudagrass Weeping Lovegrass (Ermelo) Sand Dropseed Partridge Peal	0.3 0.5 1.8 0.8 0.4 1.0
Collin Dallas Denton Ellis Kaufman Navarro Rockwell	February 1 – May 15	Green Sprangletop Bermudagrass Sideoats Grama (El Reno) Little Bluestem (Native) Buffalograss (Texoka) Illinois Bundleflower	0.3 1.2 2.7 2.0 1.6 1.0	Green Sprangletop Bermudagrass Weeping Lovegrass (Ermelo) Sand Lovegrass Sand Dropseed Partridge Pea	0.3 1.8 0.6 0.6 0.4 1.0
Hunt	February 1 – May 15	Green Sprangletop Sideoats Grama (El Reno) Bermudagrass Little Bluestem (Native) Illinois Bundleflower	0.3 3.2 1.8 1.7 1.0	Green Sprangletop Bermudagrass Bahagrass (Pensacola) Sand Lovegrass Weeping Lovegrass (Ermelo) Partridge Pea	0.3 1.5 6.0 0.6 0.8 1.0

(Source: TxDOT Standard Specifications for Construction and Maintenance of Highways, Streets and Bridges, Item 164)

County	Planting Date	Clay Soils		Sandy Soils	
		Species and Pure Live Seed Rate (Lbs/Acre)		Species and Pure Live Seed Rate (Lbs/Acre)	
Erath Hood Johnson Palo Pinto Parker Somervell Tarrant Wise	February 1 – May 15	Green Sprangletop Sideoats Grama (El Reno) Bermudagrass Buffalograss (Texoka)	0.3 3.6 2.4 1.6	Green Sprangletop Sideoats Grama (El Reno) Bermudagrass Sand Dropseed	0.3 3.6 2.1 0.3
Collin Dallas Denton Ellis Kaufman Navarro Rockwell	February 1 – May 15	Green Sprangletop Sideoats Grama (El Reno) Buffalograss (Texoka) Bermudagrass	0.3 3.6 1.6 2.4	Green Sprangletop Buffalograss (Texoka) Bermudagrass Sand Dropseed	0.3 1.6 3.6 0.4
Hunt	February 1 – May 15	Green Sprangletop Bermudagrass Sideoats Grama (Haskell)	0.3 2.4 4.5	Green Sprangletop Bermudagrass	0.3 5.4

(Source: TxDOT Standard Specifications for Construction and Maintenance of Highways, Streets and Bridges, Item 164)

Vegetation for final stabilization of channels requires grasses that are tolerant of periodic inundation, such as Bermuda grass, Kentucky bluegrass or a grass-legume mixture.

Additional Considerations

- Conditions for establishing vegetation vary significantly from site to site. Therefore, specifics of the vegetation design should be prepared based on the soil, slopes, drainage patterns, and the purpose of the vegetation at a each site.
- For construction activities that include landscaping in the development plans, the landscape architect should be consulted when specifying vegetation for temporary or final stabilization of disturbed areas.
- Vegetation is easier to establish if equipment and vehicle traffic is managed onsite to minimize soil compaction by traffic in the disturbed area that will be vegetated.
- Establishing a good vegetative cover is dependent on the season of the year. Projects that commence in the fall of the year may not be candidates for using vegetation as an erosion control.
- Where vegetation is used in swales and channels it may be necessary to use sod, rather than seeding, to establish an erosion resistant surface that accommodates rainfall runoff flows.
- Mulch should be used to enhance vegetative growth, in that mulch protects seeds from heat, prevents soil moisture loss, and provides erosion protection until the vegetation is established. Compost mulch has the additional benefit of providing some slow-release nutrients.
- Fertilizers have both beneficial and adverse effects. Fertilizers provide nutrients to the vegetation, but fertilizers are also a source of unwanted nutrients in streams and lakes. In this latter regard, they are a pollutant. The use of native vegetation rather than exotics reduces the need for fertilizers. Organic fertilizers, such as compost mulch, are generally preferred over chemical fertilizers. They provide a slow release of nutrients over a longer period of time and are less likely to cause environmental problems.
- Steep slopes represent a problem for establishing vegetation. Hydraulic mulches are useful for establishing vegetation on slopes. Refer to [Section 2.5 Mulching](#).

2.9.4 Design Guidance and Specifications

Additional criteria for the application of vegetation in channels are in [Section 3.6.3 of the iSWM Criteria Manual](#) and design guidance is in [Section 3.2 of the Hydraulics Technical Manual](#).

Specifications for construction of this item may be found in the Standard Specifications for Public Works Construction – North Central Texas Council of Governments, Item 202 Landscaping. Additional specifications for the following components of this item are in the Standard Specifications for Construction and Maintenance of Highways, Streets, and Bridges (TxDOT 2004):

- Topsoil, Item 160.
- Compost, Item 161.
- Sodding for Erosion Control, Item 162.
- Seeding for Erosion Control, Item 163.
- Fertilization, Item 164.
- Vegetative Watering 165.

2.9.5 Inspection and Maintenance Requirements

Protect newly seeded areas from excessive runoff and traffic until vegetation is established. Include a watering and fertilizing schedule in the iSWM Construction Plan facilitate the establishment of the vegetation. Vegetation for final stabilization must be maintained until the vegetative cover is 70 percent of the native background vegetative cover.

Vegetation should be inspected regularly (at least as often as required by the TPDES Construction General Permit) to ensure that the plant material is established properly and remains healthy. Bare spots shall be reseeded and/or protected from erosion by mulch or other measures. Accumulated sediment

deposited by runoff should be removed to prevent smothering of the vegetation. In addition, determine the source of excess sediment and implement appropriate measures to control the erosion.

3.4 Inlet Protection

Sediment Control

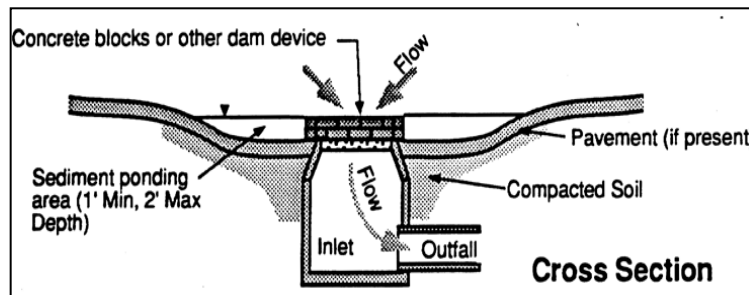

Description: Inlet protection consists of a variety of methods to intercept sediment at low point inlets through the use of depressed grading, filter stone, filter fabric, inlet inserts, organic filter tubes and other materials. The protection devices are placed around or across the inlet openings to provide localized detention or filtration of sediment and floatable materials in stormwater. Protection devices may be assembled onsite or purchased as manufactured assemblies.

KEY CONSIDERATIONS

DESIGN CRITERIA:

- Evaluate drainage patterns to ensure inlet protection will not cause flooding of roadway, property or structures
- Never block entire inlet opening
- Size according to drainage area and flow rates
- Include flow bypass for clogged controls and large storm events

ADVANTAGES / BENEFITS:

- May be the only feasible sediment control when all construction is located within rights-of-way

DISADVANTAGES / LIMITATIONS:

- Limited effectiveness and reliability
- High maintenance requirements
- Has potential to flood roadways or adjacent properties

MAINTENANCE REQUIREMENTS:

- Inspect regularly
- Check for and remove blockage of inlet after every storm event
- Remove sediment before it reaches half the design height or volume of the inlet protection, more frequently for curb inlets
- Repair or replace damaged materials
- Clean or replace filter stone and organic filter tubes is when clogged with sediment

TARGETED POLLUTANTS

- Sediment
- Nutrients & Toxic Materials
- Oil & Grease
- Floatable Materials
- Other Construction Wastes

APPLICATIONS

Perimeter Control

Slope Protection

Sediment Barrier

Channel Protection

Temporary Stabilization

Final Stabilization

Waste Management

Housekeeping Practices

Fe=0.35-0.65

(Depends on soil type)

IMPLEMENTATION CONSIDERATIONS

- Capital Costs
- Maintenance
- Training
- Suitability for Slopes > 5%

Other Considerations:

- Traffic hazards
- Passage of larger storm events without causing flooding
- Flow diversion to other inlets or drainage points

3.4.1 Primary Use

Inlet protection is typically used as a secondary sediment barrier, due to its limited effectiveness and numerous disadvantages. It is used to reduce sediment in storm sewer systems by serving as a back-up system for areas that have newly applied erosion controls or for other sediment controls that cannot achieve adequate sediment removal by themselves.

Inlet protection may be used as a primary sediment control only when all other primary controls are infeasible because of site configuration or the type of construction activity.

3.4.2 Applications

Inlet protection is best applied at low point (sump) inlets where stormwater runoff will pond behind the protection measure, and then either filter through the protection measure or flow over a weir created by it. Most inlet protection measures depend on ponding to be effective. These types of inlet protection are not applicable to on-grade curb inlets, where the inlet protection will cause stormwater runoff to bypass the inlet and overload downstream inlets. Only inlet protection measures that allow for use of the inlet opening (e.g. inlet inserts) are applicable as inlet protection for on-grade inlets.

Inlet protection is normally used in new developments with new inlets and roads that are not in public use. It has limited applications in developed areas due to the potential for flooding, traffic safety, pedestrian safety, and maintenance problems. Potential applications in developed areas are on parking lot inlets where water can pond without causing damage and during major repairs to existing roadways where no other controls are viable.

The application of inlet protection is highly variable due to the wide variety of inlet configurations (existing and new) and site conditions. The schematics in Section 6 show example applications; however, applications in most cases must be site adapted. Different methods and materials may be used. It is the responsibility of the designer to ensure that the methods and materials applied for inlet protection are appropriate to the site and flow conditions following the design criteria in Section 3.

3.4.3 Design Criteria

General

- Drainage patterns shall be evaluated to ensure inlet protection will not divert flow or flood the roadway or adjacent properties and structures.
- Inlet protection measures or devices that completely block the inlet are prohibited. They must also include a bypass capability in case the protection measures are clogged.
- Inlet protection must be designed to pass the conveyance storm (25-year, 24-hour) without creating a road hazard or damaging adjacent property. This may be accomplished by any of the following measures:
 - An overflow weir on the protection measure.
 - An existing positive overflow swale on the inlet.
 - Sufficient storage volume around the inlet to hold the ponded water until it can all filter into the inlet.
 - Other engineered method.
- Positive overflow drainage is critical in the design of inlet protection. If overflow is not provided for at the inlet, temporary means shall be provided to route excess flows through established swales, streets, or other watercourses to minimize damage due to flooding.
- Filter fabric and wire mesh used for inlet protection shall meet the material requirements specified in [Section 3.10 Silt Fence](#).

- Block and gravel (crushed stone or recycled concrete) protection is used when flows exceed 0.5 cubic feet per second and it is necessary to allow for overtopping to prevent flooding.
- The tube and filler for organic filter tubes shall be in accordance with the criteria in [Section 3.6 Organic Filter Tube](#).
- Bags used to secure inlet protection devices on pavement shall be filled with aggregate, filter stone, or crushed rock that is less likely than sand to be washed into an inlet if the bag is broken. Filled bags shall be 24 to 30 inches long, 16 to 18 inches wide, and 6 to 8 inches thick. Bags shall be polypropylene, polyethylene, or polyamide woven fabric with a minimum unit weight of 4 ounces per square yard and meet the following criteria:
 - Greater than 300 psi Mullen Burst Strength using ASTM D3786 Standard Test Method for Hydraulic Bursting Strength of Textile Fabrics-Diaphragm Bursting Strength Tester Method.
 - Greater than 70 percent UV Stability using ASTM D4355 Standard Test Method for Deterioration of Geotextiles by Exposure to Light, Moisture, and Heat in a Xenon Arc Type Apparatus.

Curb Inlet Protection

- Municipality approval is required before installing inlet protection on public streets.
- Special caution must be exercised when installing curb inlet protection on publicly traveled streets or in developed areas. Ensure that inlet protection is properly designed, installed and maintained to avoid flooding of the roadway or adjacent properties and structures.
- A two inch overflow gap or weir is required on all curb inlet protection devices.
- Traffic cones, warning signs, or other measures shall be installed to warn motorists when the inlet protection measures extend beyond the gutter line.
- 2 inch X 4 inch Weir Protection:
 - Bend wire mesh around the 2 inch x 4 inch board and staple to the board. Bend wire mesh around the bottom of the board, the curb opening, and along the pavement to form a cage for the rock.
 - Rock bags shall be placed perpendicular to the curb, at both ends of the wooden frame, to disrupt the flow and direct water into the rock filter. Stack the bags two high if needed.
- Organic Filter Tube Protection:
 - The diameter of the tube shall be at least 2 inches less than the height of the inlet opening. The tube should not be allowed to block the entire opening, since it will clog.
 - The tube shall be placed on 4 inch x 4 inch or 2 inch x 4 inch wire mesh to prevent the tube from sagging into the inlet.
 - The tube should be long enough to extend a minimum of 12 inches past the curb opening on each side of the inlet.
- Hog Wire Weir Protection:
 - The filter fabric and wire mesh shall extend a minimum of 12 inches past the curb opening on each side of the inlet.
 - Filter fabric shall be placed on 2 inch x 4 inch wire mesh to prevent the tube from sagging into the inlet.
 - Rock bags are used to hold the wire mesh and filter fabric in contact with the pavement. At least one bag shall be placed on either side of the opening, parallel to and up against the concrete curb. The bags are intended to disrupt and slow the flow and ensure it does not go under the fabric. Add bags if needed.

- If a board is used to anchor the wire mesh and fabric instead of rock bags, the board shall be secured with concrete nails at 3 inches on center. Upon removal clean any dirt or debris from the nailing locations, apply chemical sanding agent, and apply non-shrink grout flush with surface of concrete.
- Block and Gravel Protection:
 - Concrete blocks shall be standard 8 inch x 8 inch x 16 inch concrete masonry units and shall be in accordance with ASTM C139, Concrete Masonry Units for Construction. Filter gravel shall be ¾ inch washed stone containing no fines. Angular shaped stone is preferable to rounded shapes.
 - Concrete blocks are to be placed on their sides in a single row around the perimeter of the inlet, with ends abutting. Openings in the blocks should face outward, not upward. ½ inch x ½ inch wire mesh shall then be placed over the outside face of the blocks covering the holes. Filter gravel shall then be piled against the wire mesh to the top of the blocks with the base of the stone being a minimum of 18 inches from the blocks.
 - Alternatively, where loose stone is a concern (streets, etc.), the filter gravel may be placed in appropriately sized filter fabric bags.
 - Periodically, when the gravel filter becomes clogged, the gravel must be removed and cleaned in a proper manner or replaced with new gravel and piled back against the wire mesh.
- Organic Filter Tube On-Grade Protection:
 - Organic filter tubes may be used to provide sediment control at on-grade curb inlets where the tube will not be a traffic hazard, such as on residential streets where the pavement adjacent to the curb is allocated to parked cars. Tubes should not be used in this manner where they will extend into an active travel lane.
 - The filter tube shall be secured in a U-shape by rock bags. Runoff flowing in the gutter will pond within the U until it filters through the tube or overflows around the end.
- Inlet protection shall be phased on curb inlets being constructed. Controls shall be installed on the pipe inlet at the bottom of the catch basin as soon as it is installed and while the inlet box and top are being formed or placed.

Area Inlet Protection

- Installation methods for protection on area inlets vary depending on the type of inlet (drop, “Y,” or other) and the type and use of the surface surrounding the inlet (parking lot, playground, etc.). It is the responsibility of the designer to appropriately adapt inlet protection measures and their installation methods for each site condition. Several types may be needed on one project.
- Filter Fabric Protection:
 - Filter fabric protection is appropriate where the drainage area is less than one acre and the basin slope is less than five (5) percent. Filter fabric, posts, and wire mesh shall meet the material requirements specified in [Section 3.10 Silt Fence](#).
 - A 6 inch wide trench is to be cut 6 inches deep at the toe of the fence to allow the fabric to be laid below the surface and backfilled with compacted earth or gravel. This entrenchment prevents any bypass of runoff under the fence.
 - Stone overflow structures, according to the criteria in [Section 3.10 Silt Fence](#) shall be installed where flow to the inlet is concentrated and more than 1 cubic feet per second.
- Excavated Impoundment Protection:
 - Excavated inlet protection is usually the most effective type of area inlet protection; however, it is only applicable to drop inlets. It should not be applied to Y inlets because it will undermine the concrete pad surrounding the inlet opening. Nor can it be used for inlets on pavement.

- With this protection method, it is necessary to install weep holes to allow the impoundment to drain completely.
- The impoundment shall be sized such that the volume of excavation is equal to or exceeds the runoff volume from the temporary control design storm (2-year, 24-hour) for the inlet's drainage area.
- The trap shall have a minimum depth of one foot and a maximum depth of 2 feet as measured from the top of the inlet and shall have side slopes of 2:1 or flatter.
- **Block and Gravel Protection:**
 - Block and gravel inlet protection is the most stable area inlet protection and can handle more concentrated flows. It may be installed on paved or vegetated surfaces. Loose stone shall be carefully removed from vegetated surfaces at the end of construction to prevent the stone from becoming a mowing hazard.
 - The inlet protection may be one or two blocks high. Single block heights are applicable for drainage areas up to 3 acres in size. The double block height shall be used for larger drainage areas.
 - Concrete blocks shall be standard 8 inch x 8 inch x 16 inch concrete masonry units and shall be in accordance with ASTM C139, Concrete Masonry Units for Construction. Filter gravel shall be ¾ inch washed stone containing no fines. Angular shaped stone is preferable to rounded shapes.
- **Organic Filter Tube Protection:**
 - Organic filter tubes may be used on paved or unpaved surfaces.
 - On paved surfaces, tubes shall be secured in place by rock bags. On unpaved surfaces, the tubes shall be embedded in the ground a minimum of 3 inches and staked at 4 foot spacing.
 - Designer shall provide calculations and specify the diameter of tube to be used based on the inlet's drainage area and the flow rate of runoff to the inlet. The minimum allowable diameter is 12 inches.

Proprietary Inlet Protection

- Numerous proprietary protection devices are available from commercial vendors. The devices often have the advantage of being reusable on several projects if they are maintained in good condition.
- It is the policy of this manual not to recommend any specific commercial vendors for proprietary controls. However, this subsection is included in order to provide municipalities with a rationale for approving the use of a proprietary inlet protection device within their jurisdiction.
- The designer shall work with the supplier to provide the municipality with flow calculations or independent third-party tests that document the device's performance for conditions similar to the ones in which it is proposed to be installed. The conditions that should be considered include: type and size of inlet, inlet configuration, size of contributing drainage area, design flow rate, soil particle sizes to be removed, and other pollutants to be removed.
- The designer or vendor of the proprietary device shall provide a minimum of three references for projects where the device has been installed and maintained in operation at a construction site for at least six months. Local references are preferred; but references from other regions can be accepted if a similarity between the reference project and the proposed application can be demonstrated.
- Proprietary devices must not completely block the inlet. The device shall have a minimum of a 2 inch wide opening for the length of the inlet when it will be used in areas that water can safely pond to depths deeper than the design depths for the inlet. If ponding is not an option, then the device must have overflow capacity equal to the inlet design flow rate.
- Some proprietary devices are available with replaceable pads or filters. These pads or filters have the added benefit of removing pollutants such as metals and oils in addition to removing sediment.

These types of inserts are recommended in applications where prior or current land use in or adjacent to the construction areas may result in the discharge of pollutants.

- Proprietary protection devices shall be in accordance with the General criteria at the beginning of this section and any criteria listed under Curb Inlet Protection and Area Inlet Protection that are not specific to an inlet protection method.

3.4.4 *Design Guidance and Specifications*

Specifications for construction of this item may be found in the Standard Specifications for Public Works Construction – North Central Texas Council of Governments, Section 201.15 Inlet Protection.

3.4.5 *Inspection and Maintenance Requirements*

Inlet protection should be inspected regularly (at least as often as required by the TPDES Construction General Permit). Inlet controls should also be inspected after every storm event to check for collapse into the inlet or other damages that may block flow in the inlet. In addition to routine inspection, inlet protection devices should be observed and monitored during larger storm events to verify that they are not ponding or diverting water in a manner that floods a roadway or damages property.

Floatable debris and other trash caught by the inlet protection should be removed after each storm event. Sediment should also be removed from curb inlet protection after each storm event because of the limited storage area associated with curb inlets.

Sediment collected at area inlet protection should be removed before it reaches half the height of the protection device. Sediment should be removed from inlets with excavated impoundment protection before the volume of the excavation is reduced by 50 percent. In addition, the weep holes should be checked and kept clear of blockage.

Concrete blocks, 2 inch x 4 inch boards, stakes, and other materials used to construct inlet protection should be checked for damaged and repaired or replaced if damaged.

When filter fabric or organic filter tubes are used, they should be cleaned or replaced when the material becomes clogged. For systems using filter stone, when the filter stone becomes clogged with sediment, the stones must be pulled away from the inlet and cleaned or replaced.

Because of the potential for inlet protection to divert runoff or cause localized flooding, remove inlet protection as soon as the drainage area contributing runoff to the inlet is stabilized. Ensure that all inlet protection devices are removed at the end of the construction.

3.4.6 *Example Schematics*

The following schematics are example applications of the construction control. They are intended to assist in understanding the control's design and function.

The schematics are **not for construction**. They may serve as a starting point for creating a construction detail, but they must be site adapted by the designer. In addition, dimensions and notes appropriate for the application must be added by the designer.

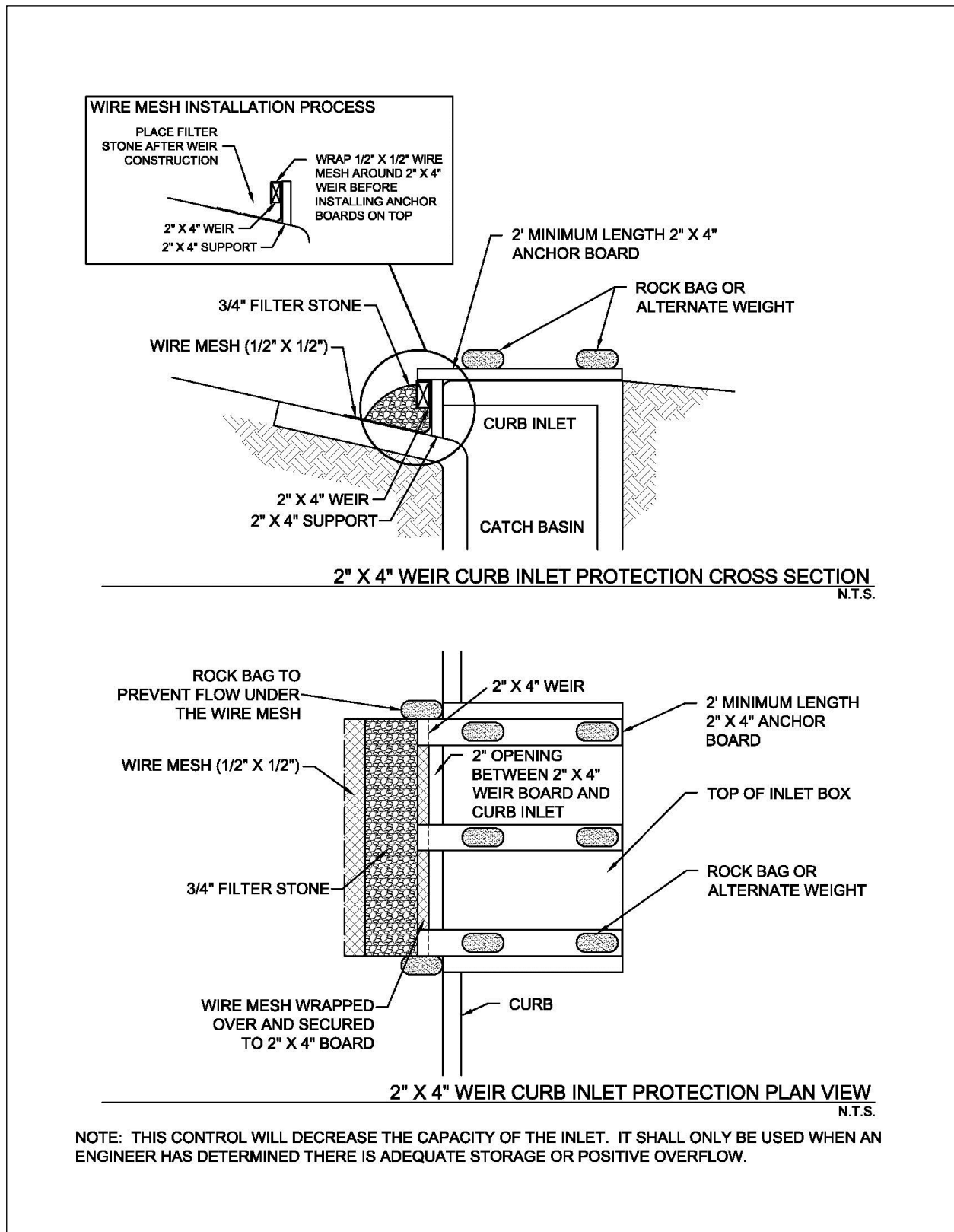

Figure 3.5 Schematics of 2"x4" Weir Curb Inlet Protection
(Source: Modified from Washington Suburban Sanitary Commission Detail SC-16.0)

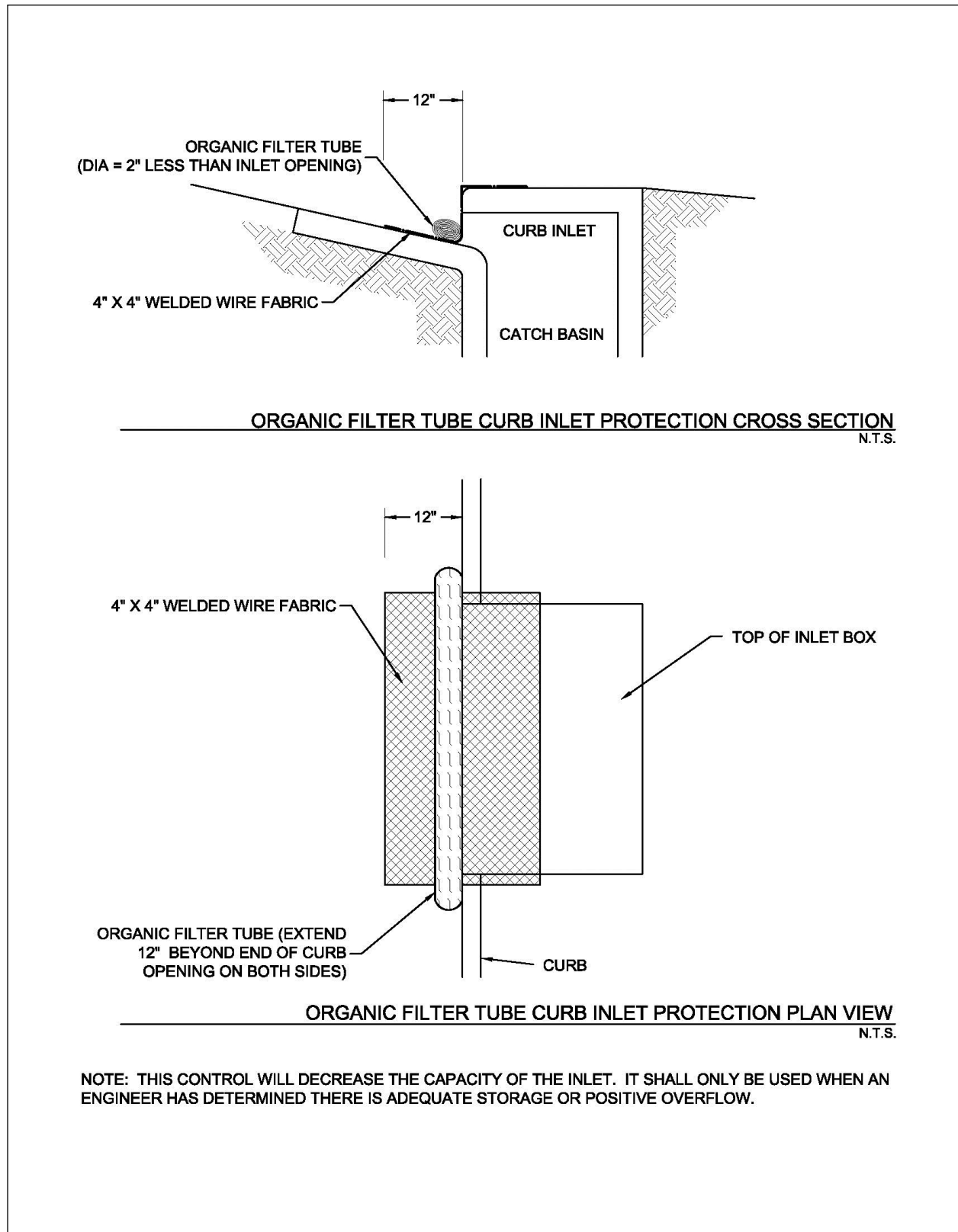

Figure 3.6 Schematics of Organic Filter Tube Curb Inlet Protection
(Source: Modified from City of Plano BMP SP-4)

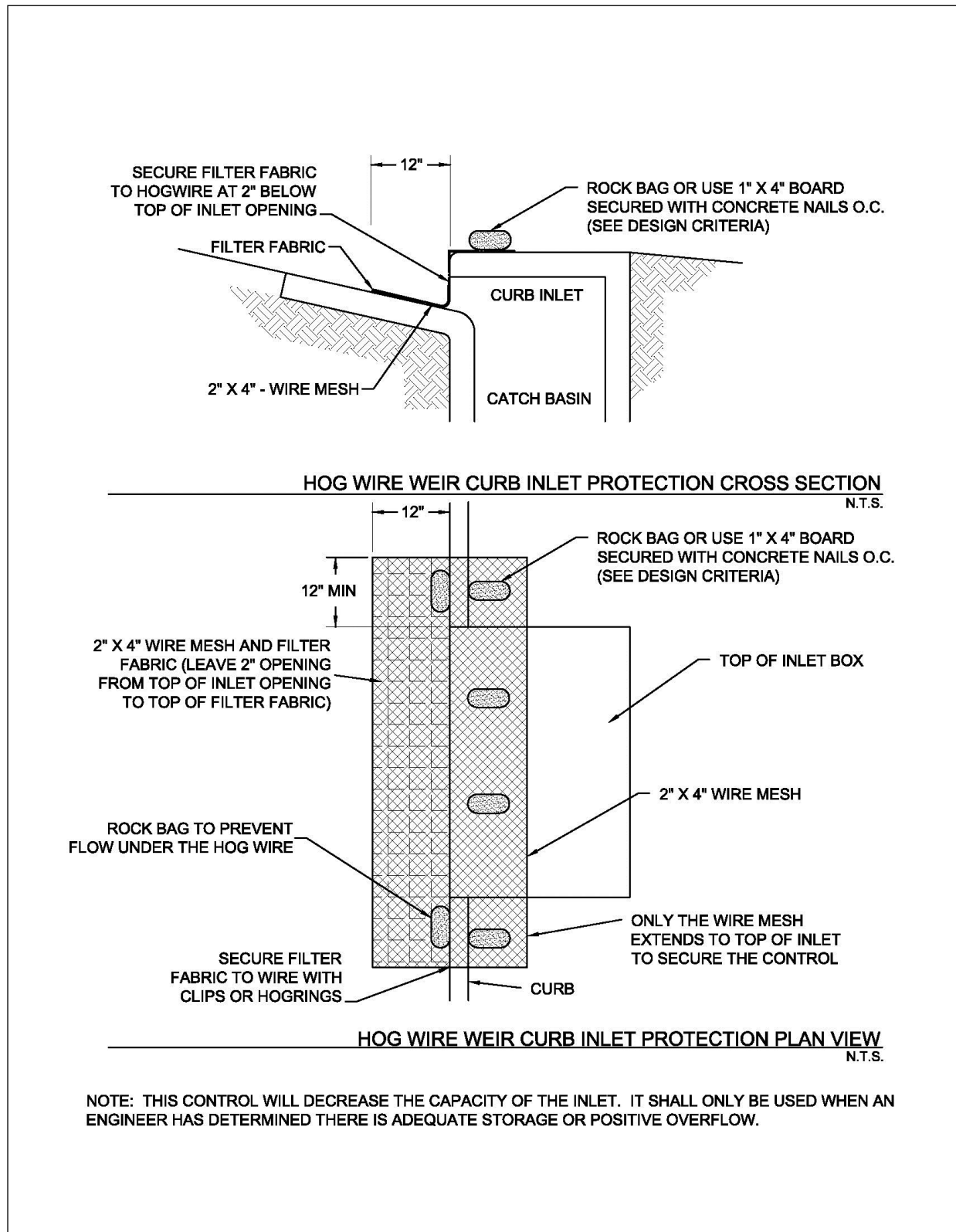

Figure 3.7 Schematics of Hog Wire Weir Curb Inlet Protection

(Source: Modified from City of Round Rock Detail E-03)

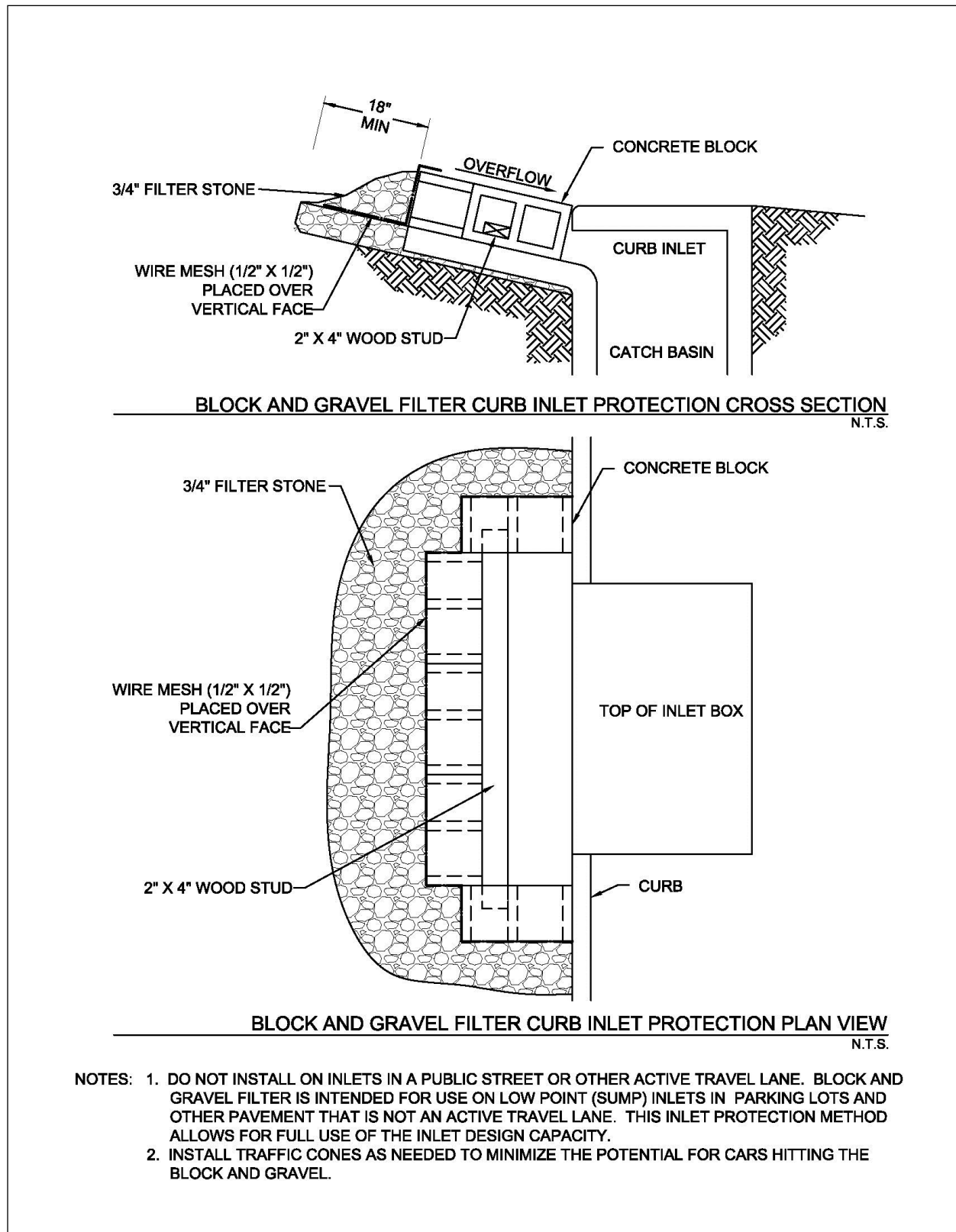

Figure 3.8 Schematics of Block and Gravel Filter Curb Inlet Protection

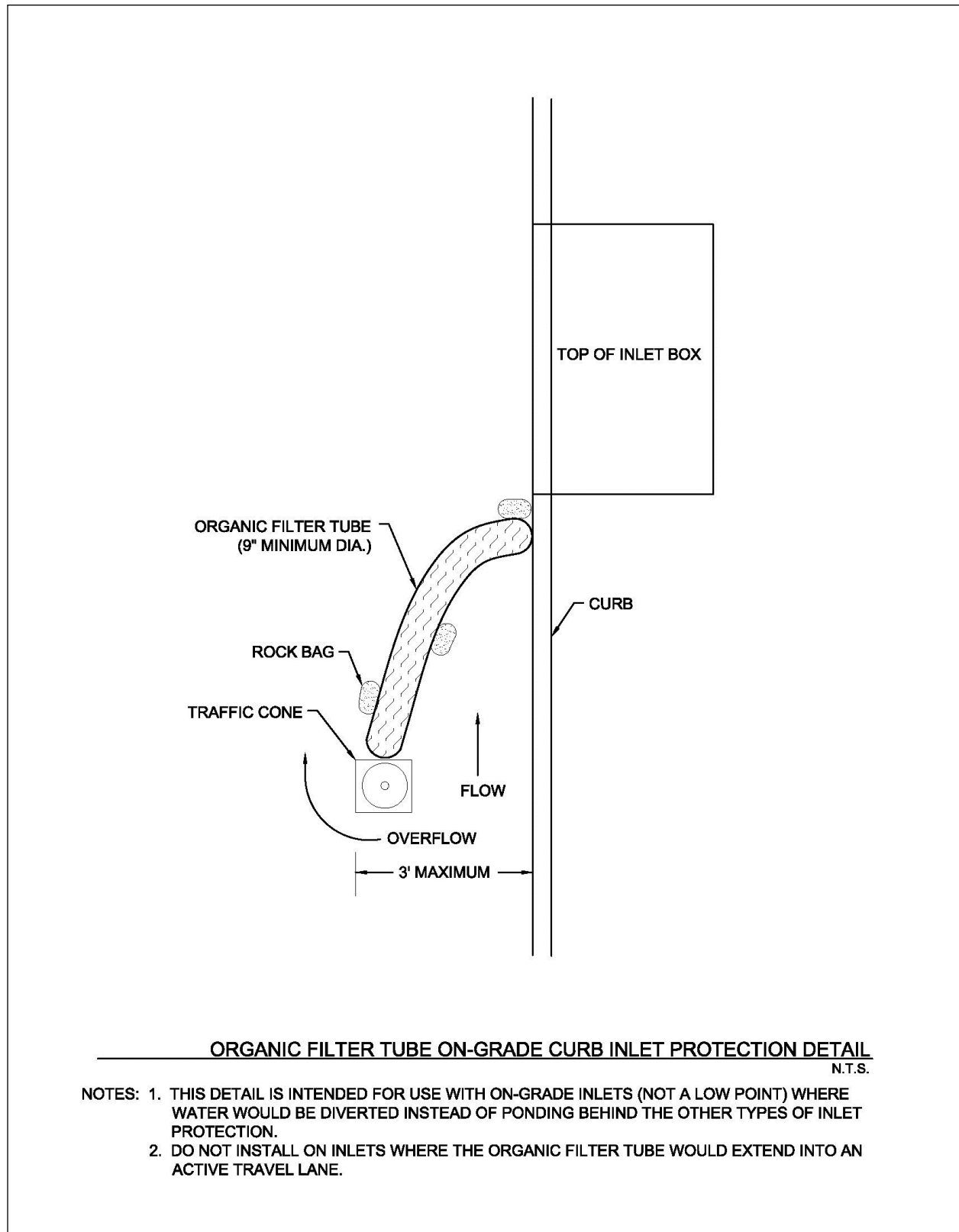

Figure 3.9 Schematic of Organic Filter Tube On-Grade Curb Inlet Protection

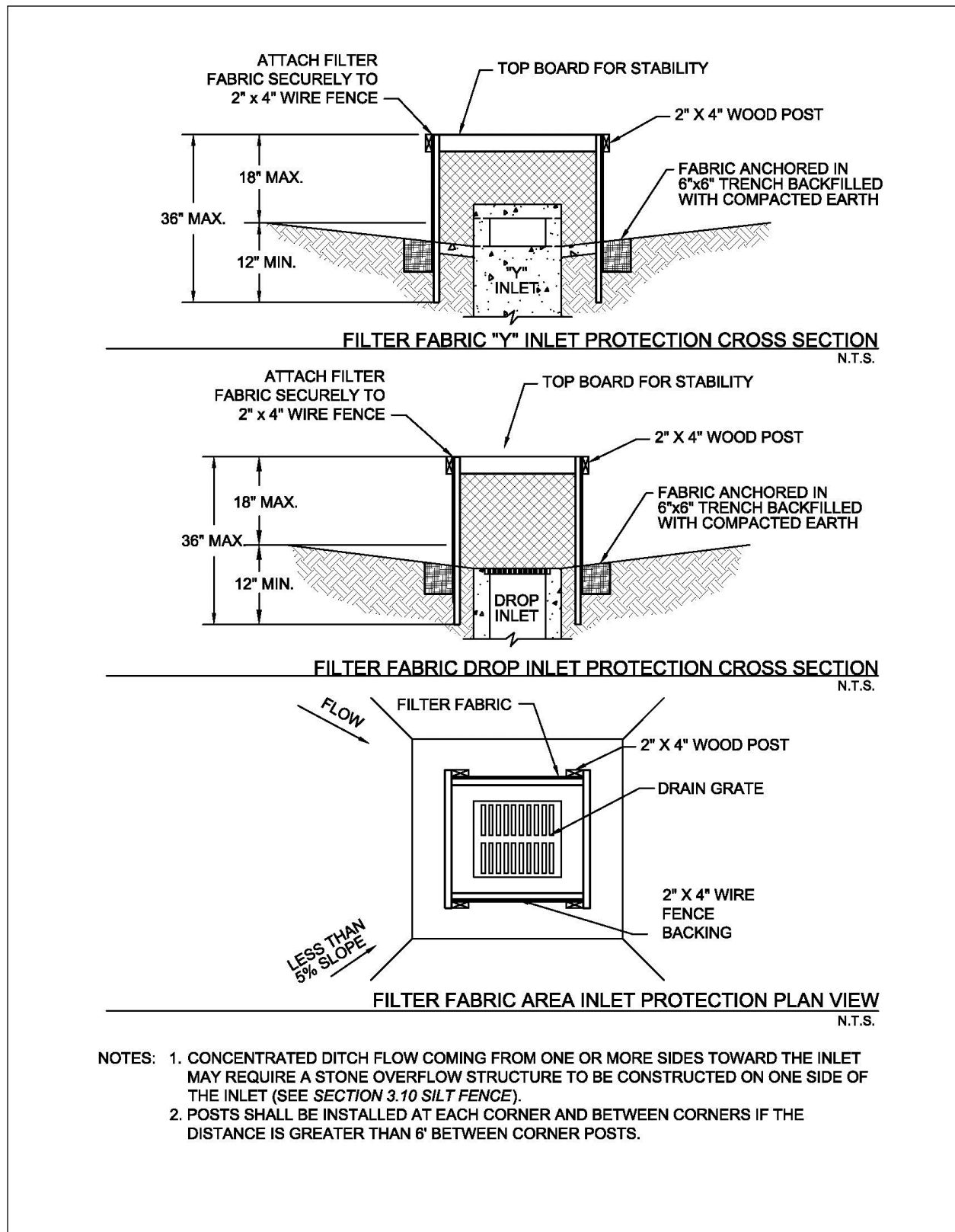

Figure 3.10 Schematics of Filter Fabric Area Inlet Protection

(Source: City of Plano BMP SP-4)

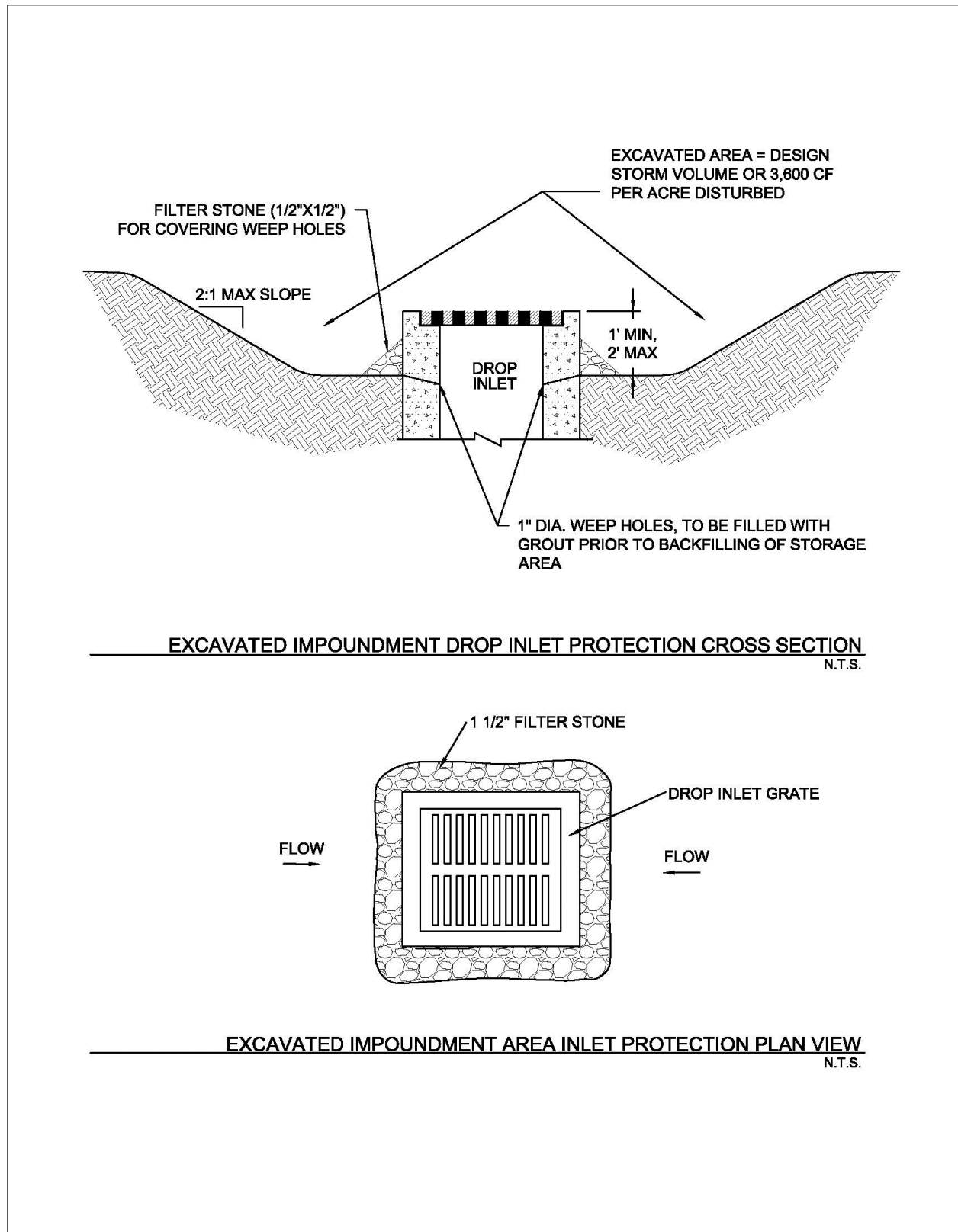

Figure 3.11 Schematics of Excavated Impoundment Area Inlet Protection

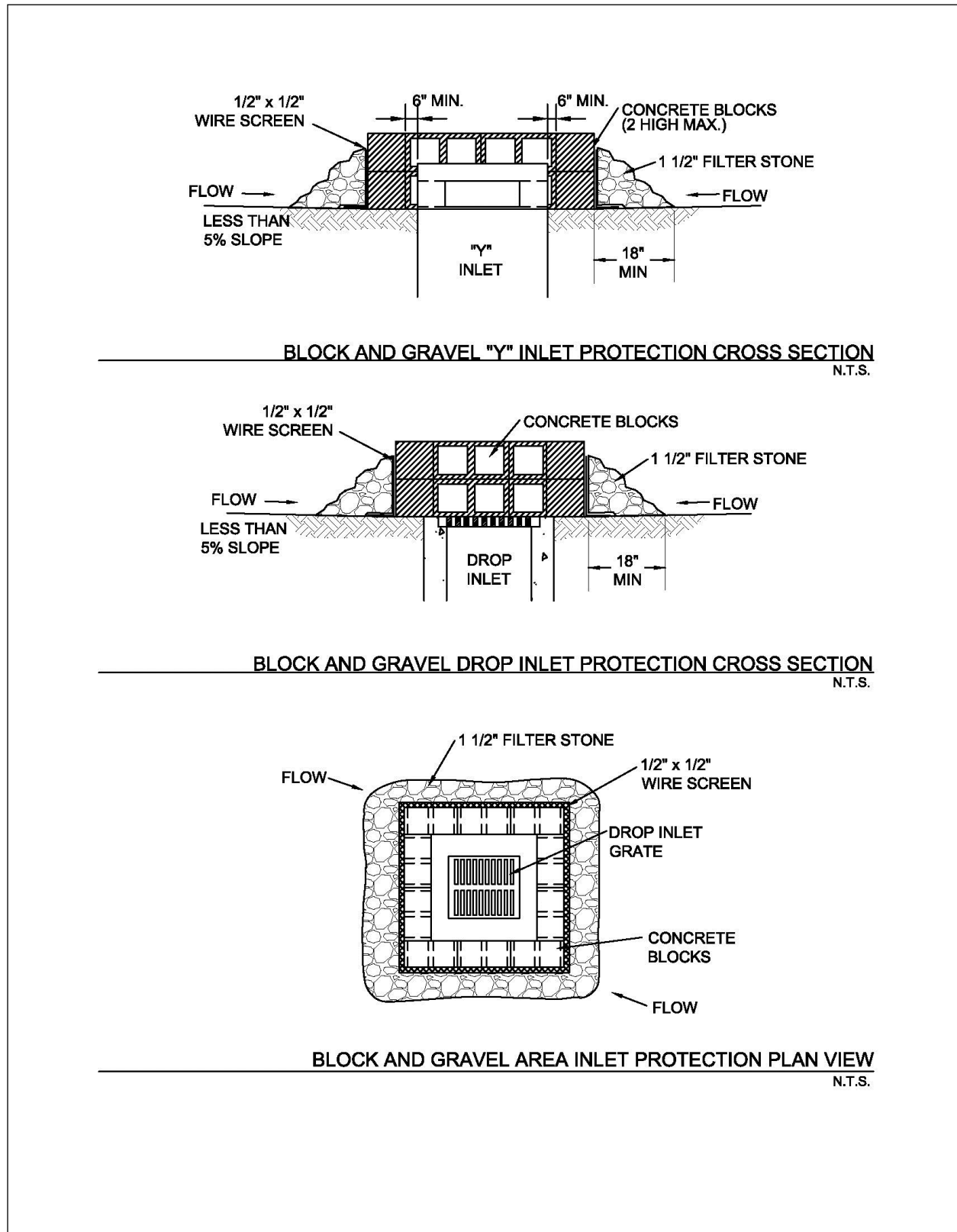

Figure 3.12 Schematics of Block and Gravel Area Inlet Protection

(Source: Modified from City of Plano BMP SP-4)

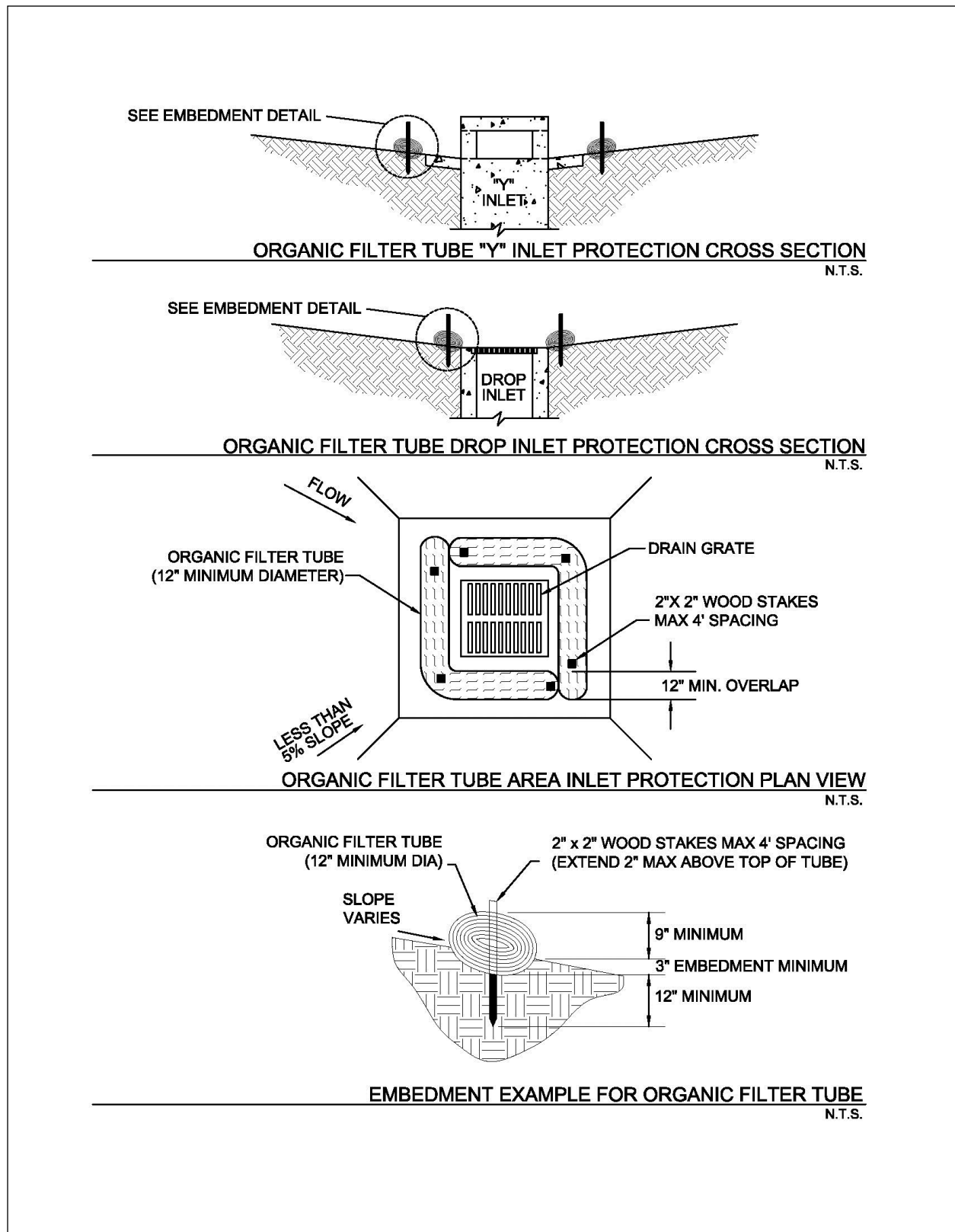
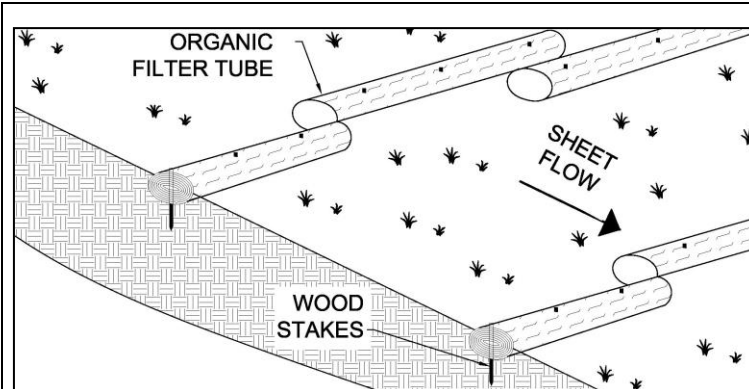

Figure 3.13 Schematics of Organic Filter Tube Area Inlet Protection

3.6 Organic Filter Tubes

Sediment Control



Description: Organic filter tubes are comprised of an open weave, mesh tube that is filled with a filter material (compost, wood chips, straw, coir, aspen fiber, or a mixture of materials). The tube may be constructed of geosynthetic material, plastic, or natural materials. Organic filter tubes are also called fiber rolls, fiber logs, wattles, mulch socks, and/or coir rolls. Filter tubes detain flow and capture sediment as linear controls along the contours of a slope or as a perimeter control down-slope of a disturbed area.

KEY CONSIDERATIONS

DESIGN CRITERIA:

- Tube diameter when filled shall be specified on the plans
- 3 inch minimum embedment in soil
- 18 inch minimum overlap at ends of tubes
- Spacing based on drainage area and slope
- Must be staked on soil and secured with rockbags on pavement
- Turn ends of tube lines upslope a minimum of 10 feet

ADVANTAGES / BENEFITS:

- Effective means to treat sheet flow over a short distance
- Relatively easy to install
- May be used on steep slopes
- Can provide perimeter control on paved surfaces or where soil type prevents embedment of other controls
- Work well as perimeter controls around stockpiles

DISADVANTAGES / LIMITATIONS:

- Difficult to remove when wet and/or filled with sediment
- Relatively small effective areas for sediment capture

MAINTENANCE REQUIREMENTS:

- Inspect regularly
- Repair eroded areas underneath the organic filter tubes
- Re-align and stake tubes that are dislodged by flow
- Remove sediment before it reaches half the height of the exposed tube

TARGETED POLLUTANTS

- Sediment
- Nutrients & Toxic Materials
- Oil & Grease
- Floatable Materials
- Other Construction Wastes

APPLICATIONS

Perimeter Control
Slope Protection
Sediment Barrier

Channel Protection

Temporary Stabilization

Final Stabilization

Waste Management

Housekeeping Practices

Fe=0.50-0.75

(Depends on soil type)

IMPLEMENTATION CONSIDERATIONS

- Capital Costs
- Maintenance
- Training
- Suitability for Slopes > 5%

Other Considerations:

- None

3.6.1 Primary Use

Organic filter tubes are long, flexible controls that are used along a line of constant elevation (along a contour) on slopes. They are used as perimeter controls down slope of disturbed areas, around temporary stockpiles and on side slopes where stormwater may runoff the area. The tubes maintain sheet flow, slow velocities, and capture sediment. When used in series on slopes, they also shorten the slope length and protect the slope from erosion.

3.6.2 Applications

Organic filter tubes include a wide variety of tube and filter materials. Organic filter tubes are used as a perimeter sediment barrier, similar to silt fence, for development projects and linear projects, such as roadways and utilities. They work well on individual residential lots and on lots being re-developed, where space may be limited. Organic filter tubes are most effective with coarse to silty soil types. Additional controls may be needed to remove fine silts and clay soils suspended in stormwater.

Organic filter tubes can be used on paved surfaces where it's not possible to stake a silt fence. Applications on paved surfaces include perimeter controls for soil stockpiles, pavement repair areas, utility trenching, and building demolition. When compost filter material is used in tubes on pavement, the material has the added benefit of removing some oil and grease from stormwater runoff.

Applications on slopes include temporary sediment control during construction and erosion control of the disturbed soil on the slope. Organic filter tubes may be used to control sheet flow on slopes when final stabilization measures are being applied and established.

Organic filter tubes may also be used for inlet protection and, in limited cases, as check dams in small drainage swales. Refer to [Section 3.4 Inlet Protection](#) and [Section 2.1 Check Dam](#) for the design criteria to use organic filter tubes in these applications.

3.6.3 Design Criteria

General Criteria

- Filter tubes should be installed along the contour.
- Tubes shall be staked with 2 inch by 2 inch wooden stakes at a maximum spacing of 4 feet. Rebar or similar metal stakes may be used instead of wooden stakes.
- When placed on pavement, sand or rock bags shall be placed abutting the down-slope side of the tubes to prevent runoff from dislodging the tubes. At a minimum, bags shall be placed one foot from each end of the tube and at the middle of the tube.
- Filter tubes shall be embedded a minimum of three inches when placed on soil. Placement on rock shall be designed as placement on pavement.
- The end of tubes shall overlap a minimum of 18 inches when multiple tubes are connected to form a linear control along a contour or a perimeter.
- Loose mulch material shall be placed against the log on the upstream side to facilitate contact with the ground.
- The last 10 feet (or more) at the ends of a line of tubes shall be turned upslope to prevent bypass by stormwater. Additional upslope lengths of tubes may be needed every 200 to 400 linear feet, depending on the traverse slope along the line of tubes.
- The most common sizes of tubes are 6 to 24 inches in diameter; however, tubes are available in sizes as small as 4 inches and up to 36 inches in diameter. The designer shall specify a diameter based on the site application. Tubes less than 8 inches in diameter when filled will require more frequent maintenance if used.

- Manufactured organic filter tube products shall have documentation of a minimum 75 percent soil retention using ASTM D7351 Standard Test Method for Determination of Sediment Retention Device Effectiveness in Sheet Flow Applications.
- When using manufactured tubes, the manufacturer's recommendations for diameter and spacing based on slope, flow velocities, and other site conditions shall be followed when they are more stringent than the design criteria in this section.
- When used as a perimeter control on grades of 10:1 or less, criteria in the following table shall be used as a guide for the size and installation rate of the organic filter tube.

<i>Drainage Area (Max)</i>	<i>Max Flow Length to the Tube</i>	<i>Tube Diameter (Min)</i>
1/3 Acre per 100 feet	145 feet	18 inches
1/4 Acre per 100 feet	110 feet	15 inches
1/5 Acre per 100 feet	85 feet	12 inches
1/8 Acre per 100 feet	55 feet	9 inches

(Source: Modified and expanded from City of Plano Fact Sheet SP-13)

*Applicable on grades of 10:1 or flatter.

- When installing organic filter tubes along contours on slopes, criteria in the following table shall be used as a general guide for size and spacing of the tubes. Actual tube diameter and spacing shall be specified by the designer. The designer shall consider the tube manufacturers recommendations, the soil type, flow volume on the slope, required performance life, and erosion control measures that may be used in conjunction with the tubes.

<i>Slope (H:V)</i>	<i>Tube Diameter (Min)</i>			
	<i>9 Inches</i>	<i>12 Inches</i>	<i>18 Inches</i>	<i>24 Inches</i>
5:1 to 10:1	35 feet	40 feet	55 feet	60 feet
4:1	30 feet	40 feet	50 feet	50 feet
3:1	25 feet	35 feet	40 feet	40 feet
2:1	20 feet	25 feet	30 feet	30 feet
1:1	10 feet	15 feet	20 feet	20 feet

(Source: Modified and expanded from Iowa Statewide Urban Design and Specifications Standards for Filter Socks)

Tube Material

- The designer shall specify the type of mesh based on the required life of the tube. At a minimum, the mesh shall have a rated life of one year under field conditions.
- If the tubes will be left onsite as part of the final stabilization, they must be constructed of 100 percent biodegradable jute, coir, sisal or similar natural fiber or 100 percent UV photodegradable plastic, polyester or geosynthetic material.
- Mesh tubes may be oval or round in cross-section.
- Mesh for the tubes shall be open and evenly woven. Size of weave openings shall be specified based on filter material. Openings may range from ½ inch for Erosion Control Compost to 2 inches for straw and coir.
- Mesh openings should not exceed ½ inch in diameter.

Filter Material

- Different filter materials have different properties and will affect sheet flow differently. The designer shall specify the type of material to be used (or excluded) on a particular site.
- Straw filter material shall be Certified Weed Free Forage. The straw must be in good condition, air-dried, and not rotten or moldy.
- Compost shall conform to the requirements for Erosion Control Compost in Item 161 of the Standard Specifications for Construction and Maintenance of Highways, Streets, and Bridges (TxDOT 2004).
- Compost may provide some oil and grease removal; however, the large percentage of fines in compost will result in less filtering and more ponding of stormwater.
- Wood chips shall be 100 percent untreated chips and free of inorganic debris, such as plastic, glass, metal, etc. Wood chip size shall not be smaller than 1 inch and shall not exceed 3 inches in diameter. Shavings shall not be more than 5% of the total mass.

3.6.4 Design Guidance and Specifications

Specifications for Erosion Control Compost to be used as filter material may be found in Item 161 of the Standard Specifications for Construction and Maintenance of Highways, Streets, and Bridges (TxDOT 2004).

3.6.5 Inspection and Maintenance Requirements

Organic filter tubes should be inspected regularly (at least as often as required by the TPDES Construction General Permit). The filter tube should be checked to ensure that it is in continuous contact with the soil at the bottom of the embedment trench. Closely check for rill erosion that may develop under the filter tubes. Eroded spots must be repaired and monitored to prevent reoccurrence. If erosion under the tube continues, additional controls are needed.

Staking shall be checked to ensure that the filter tubes are not moving due to stormwater runoff. Repair and re-stake slumping filter tubes. Tubes that are split, torn or unraveling shall be repaired or replaced.

Check the filter tube material to make sure that it has not become clogged with sediment or debris. Clogged filter tubes usually lead to standing water behind the filter tube after the rain event. Sediment shall be removed from behind the filter tube before it reaches half the height of the exposed portion of the tube.

When sediment control is no longer needed on the site, the tubes may be split open and the filter material may be used for mulching during establishment of vegetation for final stabilization if it meets the criteria in [Section 2.5 Mulching](#).

3.6.6 Example Schematics

The following schematics are example applications of the construction control. They are intended to assist in understanding the control's design and function.

The schematics are **not for construction**. They may serve as a starting point for creating a construction detail, but they must be site adapted by the designer. In addition, dimensions and notes appropriate for the application must be added by the designer.

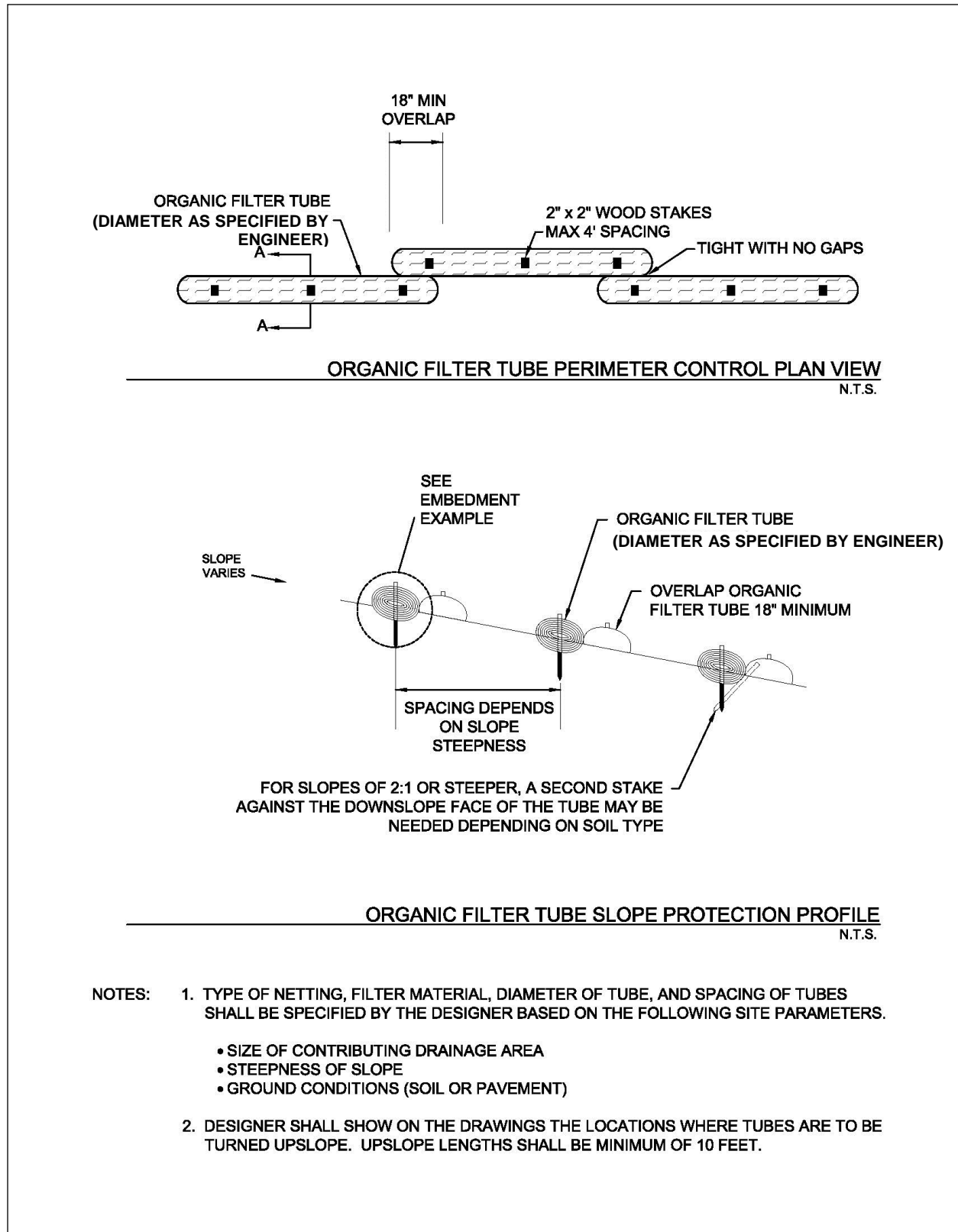

Figure 3.15 Schematics of Organic Filter Tubes

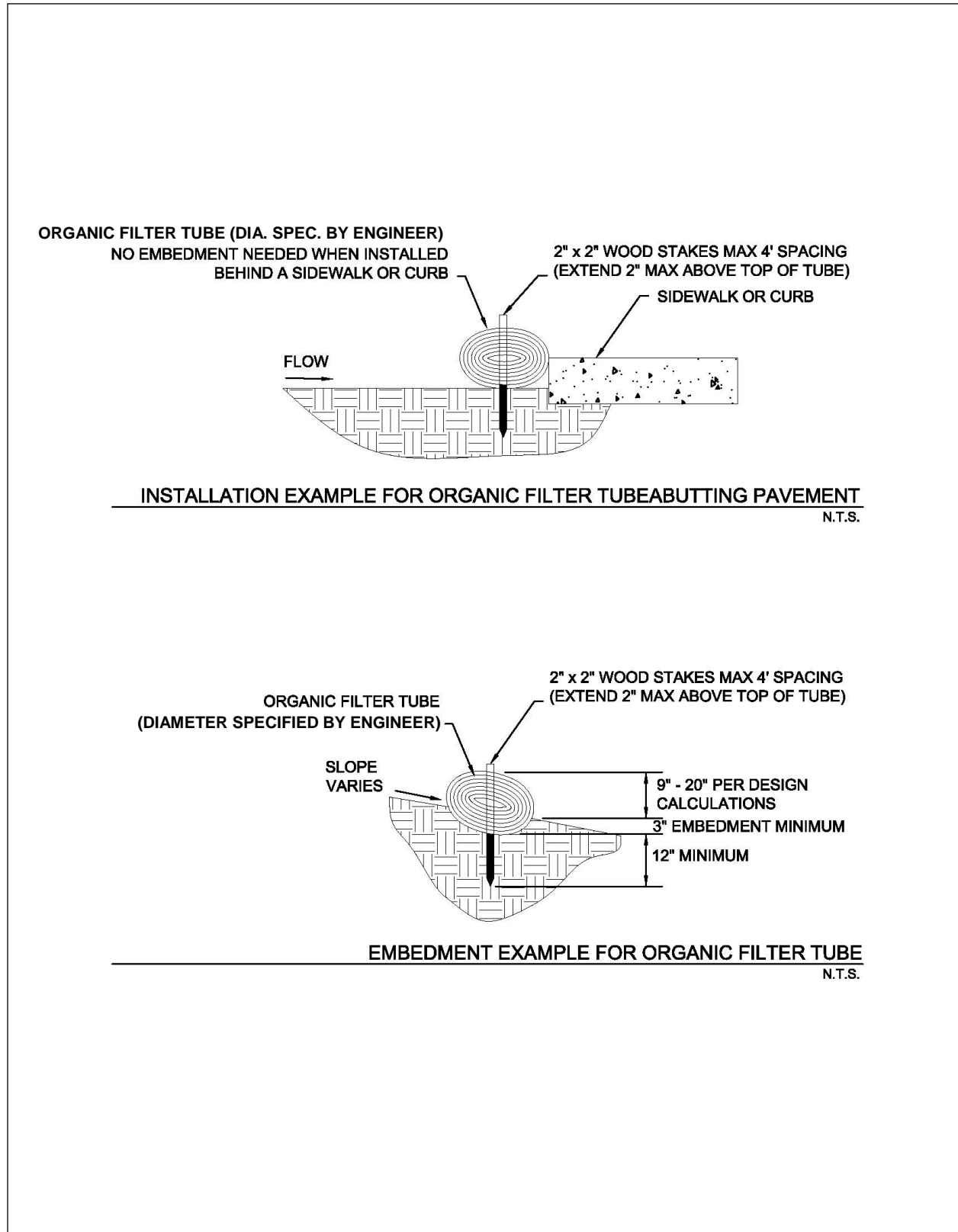
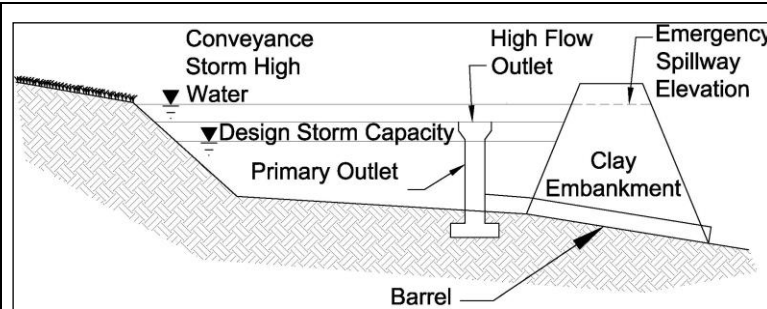

Figure 3.16 Examples of Organic Filter Tube Installation Methods

3.9 Sediment Basin

Sediment Control



Description: A sediment basin is an embankment with a controlled outlet that detains stormwater runoff, resulting in the settling of suspended sediment. The basin provides treatment for the runoff as well as detention and controlled release of runoff, decreasing erosion and flood impacts downstream.

KEY CONSIDERATIONS

DESIGN CRITERIA:

- Minimum 4:1 length to width ratio
- Maximum embankment height and storage capacity limited by TCEQ requirements
- Minimum dewatering time of 36 hours
- Safely pass 25-year, 24-hour storm event without structure damage

ADVANTAGES / BENEFITS:

- Effective at removing suspended sand and loam
- May be both a temporary and permanent control
- Can be used in combination with passive treatment

DISADVANTAGES / LIMITATIONS:

- Effectiveness depends on type of outlet
- Limited effectiveness in removing fine silt and clay
- May require a relatively large portion of the site
- Storm events that exceed the design storm event may damage the structure and cause downstream impacts

MAINTENANCE REQUIREMENTS:

- Inspect regularly
- Remove obstructions from discharge structures
- Remove sediment and re-grade basin when storage capacity reduced by 20 percent

TARGETED POLLUTANTS

- Sediment
- Nutrients & Toxic Materials
- Oil & Grease
- Floatable Materials
- Other Construction Wastes

APPLICATIONS

Perimeter Control

Slope Protection

Sediment Barrier

Channel Protection

Temporary Stabilization

Final Stabilization

Waste Management

Housekeeping Practices

Fe=0.50-0.90

(Depends on soil type)

IMPLEMENTATION CONSIDERATIONS

- Capital Costs
- Maintenance
- Training
- Suitability for Slopes > 5%

Other Considerations:

- Public safety
- Mosquito breeding habitat
- Requires comprehensive planning and design

3.9.1 Primary Use

Sediment basins should be used for all sites with adequate open space for a basin and where the site topography directs a majority of the site drainage to one point. Sediment basins are necessary as either temporary or permanent controls for sites with disturbed areas of 10 acres and larger that are part of a common drainage area unless specific site conditions limit their use.

3.9.2 Applications

Sediment basins serve as treatment devices that can be used on a variety of project types. They are normally used in site development projects in which large areas of land are available for the basin, a minor stream or off-line drainage way crosses the site, or a specific water feature is planned for the site. Sediment basins are highly effective at reducing sediment and other pollutants for design storm conditions. Sediment basins are typically easier to maintain than other structural controls (e.g. silt fences, etc).

A sediment basin by itself does not typically remove a sufficient percentage of fine silts and clays to be an effective sediment barrier. Table 3.3 provides a summary of sediment basin effectiveness based on soil type.

Soil Type	Runoff Potential	Settling Rate	Sediment Basin Effectiveness	Efficiency Rating (Fe)
Sand	Low	High	High	0.90
Sandy Loam	Low	High	High	0.90
Sandy Silt Loam	Moderate	Moderate	Moderate	0.75
Silt Loam	Moderate	Moderate	Moderate	0.75
Silty Clay Loam	Moderate	Low	Low	0.75
Clay Loam	Great	Low	Low	0.50
Clay	Great	Low	Low	0.50

(Source: Michigan Department of Environmental Quality Soil Erosion and Sedimentation Control Training Manual)

When the disturbed area contains a high percentage of fine silt or clay soil types, the sediment basin may be used with a passive or active treatment system to remove these finer suspended solids. Design criteria may be found in [Section 3.1 Active Treatment System](#) and [Section 3.7 Passive Treatment System](#).

3.9.3 Design Criteria

Texas Administrative Code Title 30, Chapter 299 (30 TAC 299), Dams and Reservoirs, contains specific requirements for dams that:

- Have a height greater than or equal to 25 feet and a maximum storage capacity greater than or equal to 15 acre-feet; or
- Have a height greater than six feet and a maximum storage capacity greater than or equal to 50 acre feet.

If the size of the detention basin meets or exceeds the above applicability, the design must be in accordance with state criteria, and the final construction plans and specifications must be submitted to the TCEQ for review and approval.

The following design criteria are for temporary sediment basins that are smaller than the TCEQ thresholds. The sediment basin shall be designed by a licensed engineer in the State of Texas. The criteria and schematics are the minimum and, in some cases, only concept level. It is the responsibility of the engineer to design and size the embankment, outfall structures, overflow spillway, and downstream

energy dissipaters and stabilization measures. Alternative designs may be acceptable if submitted to the reviewing municipality with supporting design calculations.

Sediment Basin Location and Planning

- Design of the sediment basin should be coordinated with design of the permanent drainage infrastructure for the development.
- The basin shall not be located within a mapped 100-year floodplain unless its effects on the floodplain are modeled, and the model results are approved by the reviewing municipality.
- Basins shall not be located on a live stream that conveys stormwater from upslope property through the construction site.
- Basins may be located at the discharge point of a drainage swale that collects runoff from construction activities, or the basin may be located off-channel with a swale or dike constructed to divert runoff from disturbed areas to the basin. Design criteria for these controls are in [Section 2.2 Diversion Dike](#) and [Section 2.4 Interceptor Swale](#).
- Sediment basins must be designed, constructed, and maintained to minimize mosquito breeding habitats by minimizing the creation of standing water.
- Temporary stabilization measures should be specified for all areas disturbed to create the basin.

Basin Size

- Minimum capacity of the basin shall be the calculated volume of runoff from a 2-year, 24-hour duration storm event plus sediment storage capacity of at least 1,000 cubic feet.
- The basin must be laid out such that the effective flow length to width ratio of the basin is a minimum of 4:1. Settling efficiencies are dependent on flow velocity, basin length, and soil type. Smaller particle sizes require slower velocities and longer basins. Basin dimensions should be designed based on flow velocities and anticipated particle sizes.
- Stoke's equation for settling velocities, as modified to Newton's equation for turbulent flow, may be used to estimate length required based on depth of the basin.

$$\text{Settling Velocity (ft/s)} = 1.74 [(\rho_p - \rho)gd/\rho]^{1/2} \quad (3.1)$$

Where:

ρ_p = density of particles (lb/ ft³)

ρ = density of water (lb/ft³)

g = gravitational acceleration (ft/s²)

d = diameter of particles (ft)

- The effective length of sediment basins may be increased with baffles. Baffles shall be spaced at a minimum distance of 100 feet. Spacing should be proportional to the flow rate, with greater spacing for higher flow rates. Check the flow velocity in the cross section created by the baffles to ensure settling will occur.
- Baffles may be constructed by using excavated soil to create a series of berms within the basin; however, porous baffles are recommended. Porous baffles may consist of coir fiber, porous geotextiles, porous turbidity barriers, and similar materials. Porous materials disrupt the flow patterns, decrease velocities, and increase sedimentation.
- Basins have limited effectiveness on suspended clay soil particles. The basin's length to width ratio typically should be 10:1 to effectively remove suspended clay particles. The use of passive treatment systems can significantly reduce this ratio and improve removal rates. Criteria are in [Section 3.7 Passive Treatment System](#).

Embankment

- Top width shall be determined by the engineer based on the total height of the embankment as measured from the toe of the slope on the downstream side.
- Embankment side slopes shall be 3:1 or flatter.
- The embankment shall be constructed with clay soil, minimum Plasticity Index of 30 using ASTM D4318 Standard Test for Liquid Limit, Plastic Limit, and Plasticity Index of Soils.
- Clay soil for the embankment shall be placed in 8 inch lifts and compacted to 95 percent Standard Proctor Density at optimum moisture content using ASTM D698 Standard Test Methods for Laboratory Compaction Characteristics of Soil Using Standard Effort.
- The embankment should be stabilized with rock riprap or temporary vegetation.

Outlet and Spillway

- The primary outlet shall have a minimum design dewatering time of 36 hours for the temporary control design storm (2-year, 24-hour).
- Whenever possible, the outlet shall be designed to drain the basin in less than 72 hours to minimize the potential for breeding mosquitoes.
- The basin's primary outlet and spillway shall be sized to pass the difference between the conveyance storm (25-year, 24-hour) and the temporary control design storm without causing damage to the embankment and structures.
- Unless infeasible, the primary outlet structure should withdraw water from the surface of the impounded water. Outlet structures that do this include surface skimmers, solid risers (non-perforated), flashboard risers, and weirs.
- Surface skimmers use a floating orifice to discharge water from the basin. Skimmers have the advantage of being able to completely drain the detention basin. Skimmers typically result in the greatest sediment removal efficiency for a basin, because they allow for a slower discharge rate than other types of surface outlets. Due to this slower discharge rate, a high flow riser may still be needed to discharge the conveyance storm if a large enough spillway is not feasible due to site constraints.
- Discharge rates for surface skimmers are dependent on the orifice configuration in the skimmer. Use manufacturer's flow rate charts to select the skimmer based on the flow rate needed to discharge the design storm from the basin within a selected time period (i.e. $Q = \text{Volume}/\text{time}$).
- Risers shall be designed using the procedures in [Section 3.9.7 Design Procedures](#).
- Weir outlets should be designed using the guidance in [Section 2.2.2 of the Hydraulics Technical Manual](#).
- Use of overflow risers and weirs result in a pool of water that should be accounted for in the design capacity of the basin. These outlet structures are good options when the temporary sediment basin will be retained as a permanent site feature upon completion of construction. If the basin is temporary and standing water is not acceptable during construction, the construction plans shall include procedures for dewatering the basin following criteria in [Section 3.3 Dewatering Controls](#).
- Flashboard risers function like an overflow riser pipe, but they contain a series of boards that allow for adjustment of the pool level. The boards may be removed for draining the basin to a lower level. However, this operation can be difficult and a safety hazard when done manually.
- A perforated riser may be used as an outlet when surface discharge is not feasible. A perforated riser has the advantage of dewatering the basin; however, it also results in the lowest sediment removal efficiency. Perforated risers provide a relatively rapid drawdown of the pool, and they discharge water from the entire water column, resulting in more suspended sediment being discharged than with a surface outlet.

- Size and spacing of the orifices on a perforated riser shall be designed to provide the minimum detention time while allowing for the drawdown of detained water.
- Gravel (1½ to 3 inches) may be placed around the perforated riser to aid sediment removal, particularly the removal of fine soil particles, and to keep trash from plugging the perforations. The gravel is most effective when the basin will be used for less than a year. When installed for longer periods of time, the gravel may become clogged with fine sediments and require cleaning while submerged.
- The outlet of the outfall pipe (barrel) shall be stabilized with riprap or other materials designed using the conveyance storm flow rate and velocity. Velocity dissipation measures shall be used to reduce outfall velocities in excess of 5 feet per second.
- The outfall pipe through the embankment shall be provided with anti-seep collars connected to the exterior of the pipe section or at a normal joint of the pipe material. The anti-seep collar material shall be compatible with the pipe material used and shall have a watertight bond to the exterior of the pipe section. The size and number of collars shall be selected by the designer in accordance with the following formula and table:

Collar Outside Dimension = X + Diameter of pipe in feet

Example: Pipe Length = 45 feet
 Barrel Pipe Diameter = 12 inches = 1 foot
 2 anti-seep collars

Anti-seep Collar Dimensions:

3.4 feet (from table) + 1.0 foot (Pipe dia.) = 4.4 feet

Use 2 anti-seep collars each being 4.4 feet square or 4.4 feet diameter if round.

Pipe Length	X Values - Feet			
	Number of Anti-Seep Collars			
	1	2	3	4
40	6.0	3.0		
45	6.8	3.4		
50	7.5	3.8	2.5	
55		4.2	2.8	
60		4.5	3.0	
65		4.9	3.3	
70		5.3	3.5	2.6
75		5.6	3.8	2.8
80		6.0	4.0	3.0

- Risers used to discharge high flows shall be equipped with an anti-vortex device and trash rack.
- Spillways shall be constructed in undisturbed soil material (not fill) and shall not be placed on the embankment that forms the basin.

3.9.4 Design Guidance and Specifications

Design guidance for temporary sediment basins is in [Section 3.9.7 Design Procedures](#). Criteria for sediment basins that will become permanent detention basins are in [Section 3.6.3 of the iSWM Criteria Manual](#). Additional design guidance for different types of outlet structures is in [Section 2.2 of the Hydraulics Technical Manual](#).

No specification for construction of this item is currently available in the Standard Specifications for Public Works Construction – North Central Texas Council of Governments.

3.9.5 *Inspection and Maintenance Requirements*

Sediment basins should be inspected regularly (at least as often as required by the TPDES Construction General Permit) to check for damage and to insure that obstructions are not diminishing the effectiveness of the structure. Sediment shall be removed and the basin shall be re-graded to its original dimensions when the sediment storage capacity of the impoundment has been reduced by 20 percent. The removed sediment may be stockpiled or redistributed onsite in areas that are protected by erosion and sediment controls.

Inspect temporary stabilization of the embankment and graded basin and the velocity dissipaters at the outlet and spillway for signs of erosion. Repair any eroded areas that are found. Install additional erosion controls if erosion is frequently evident.

3.9.6 *Example Schematics*

The following schematics are example applications of the construction control. They are intended to assist in understanding the control's design and function.

The schematics are **not for construction**. Dimensions of the sediment basin, embankment, and appurtenances shall be designed by an engineer licensed in the State of Texas. Construction drawings submitted to the municipality for review shall include, but are not limited to, the following information and supporting calculations.

- Embankment height, side slopes and top width.
- Dimensions of the skimmer, riser, weir or other primary outlet.
- Diameter of outfall pipe (barrel).
- Pool elevation for the temporary control design storm and conveyance storm.
- Outfall pipe flow rate and velocity for the temporary control design storm and conveyance storm.
- Spillway cross section, slope, flow rate, and velocity for the conveyance storm.
- Depth, width, length, and mean stone diameter for riprap apron or other velocity dissipation device at the outfall pipe and spillway discharge points.

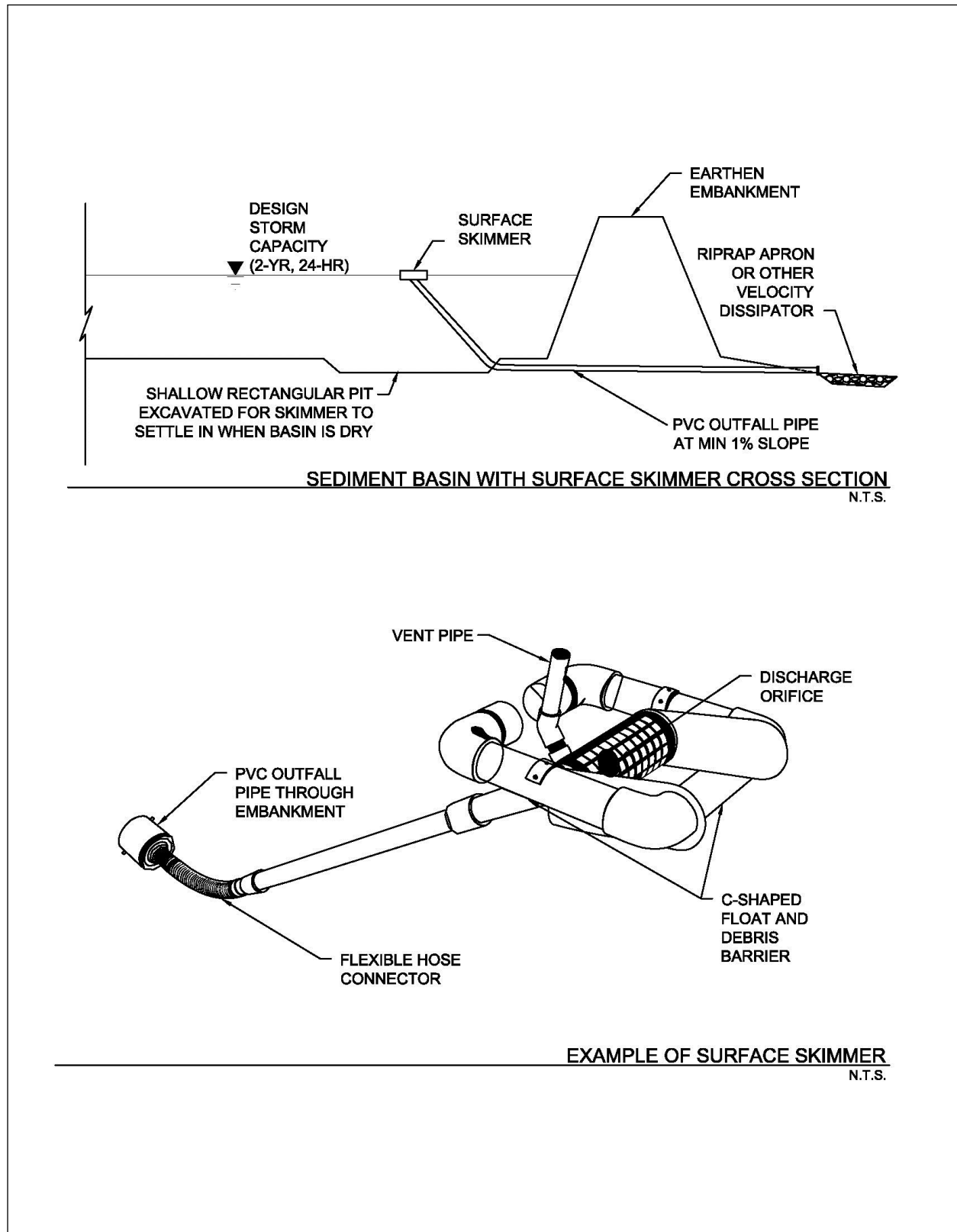

Figure 3.19 Schematics of Sediment Basin with Surface Skimmer

(Source: J.W. Faircloth & Son, Inc.)

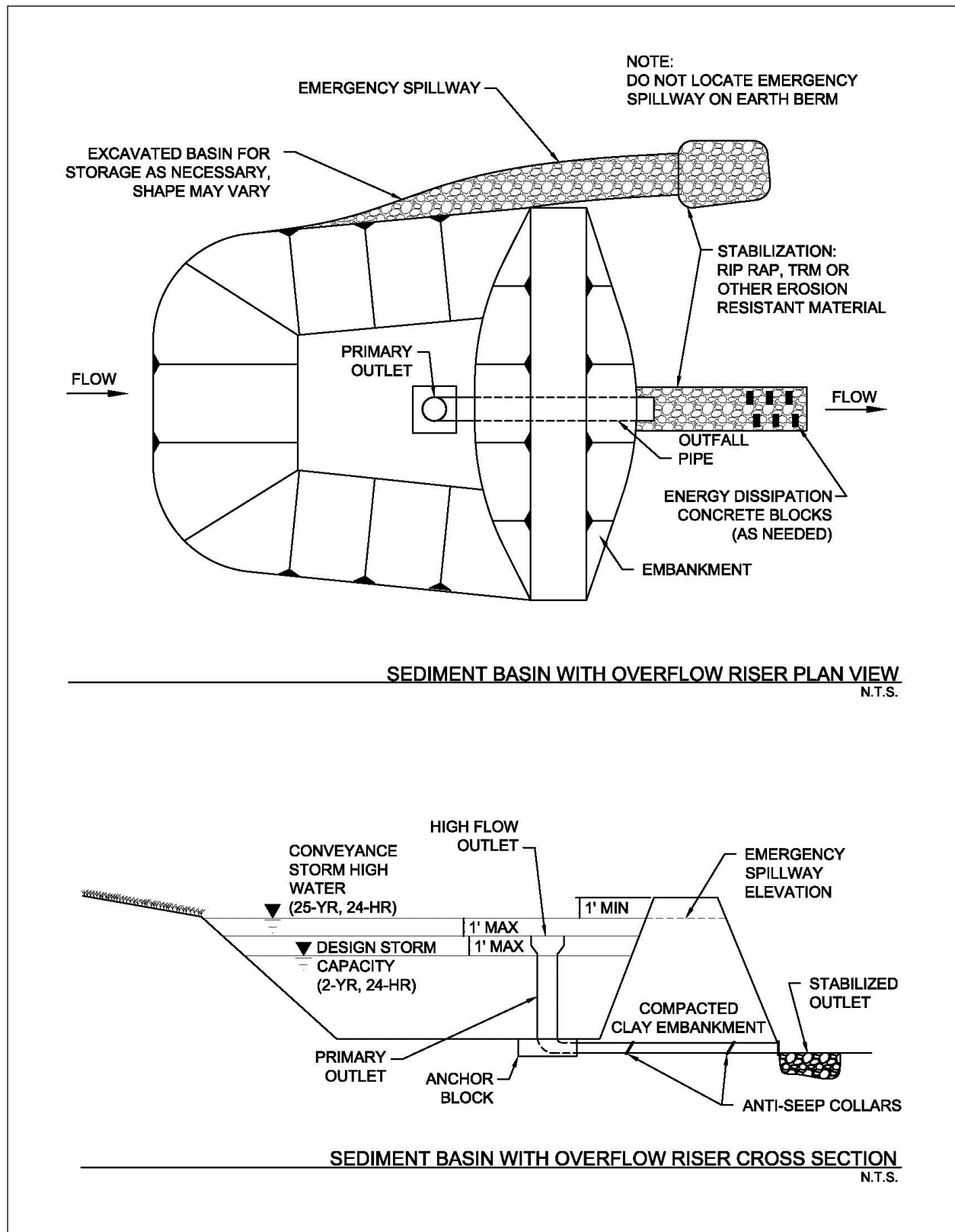

Figure 3.20 Schematics of Sediment Basin with Overflow Riser

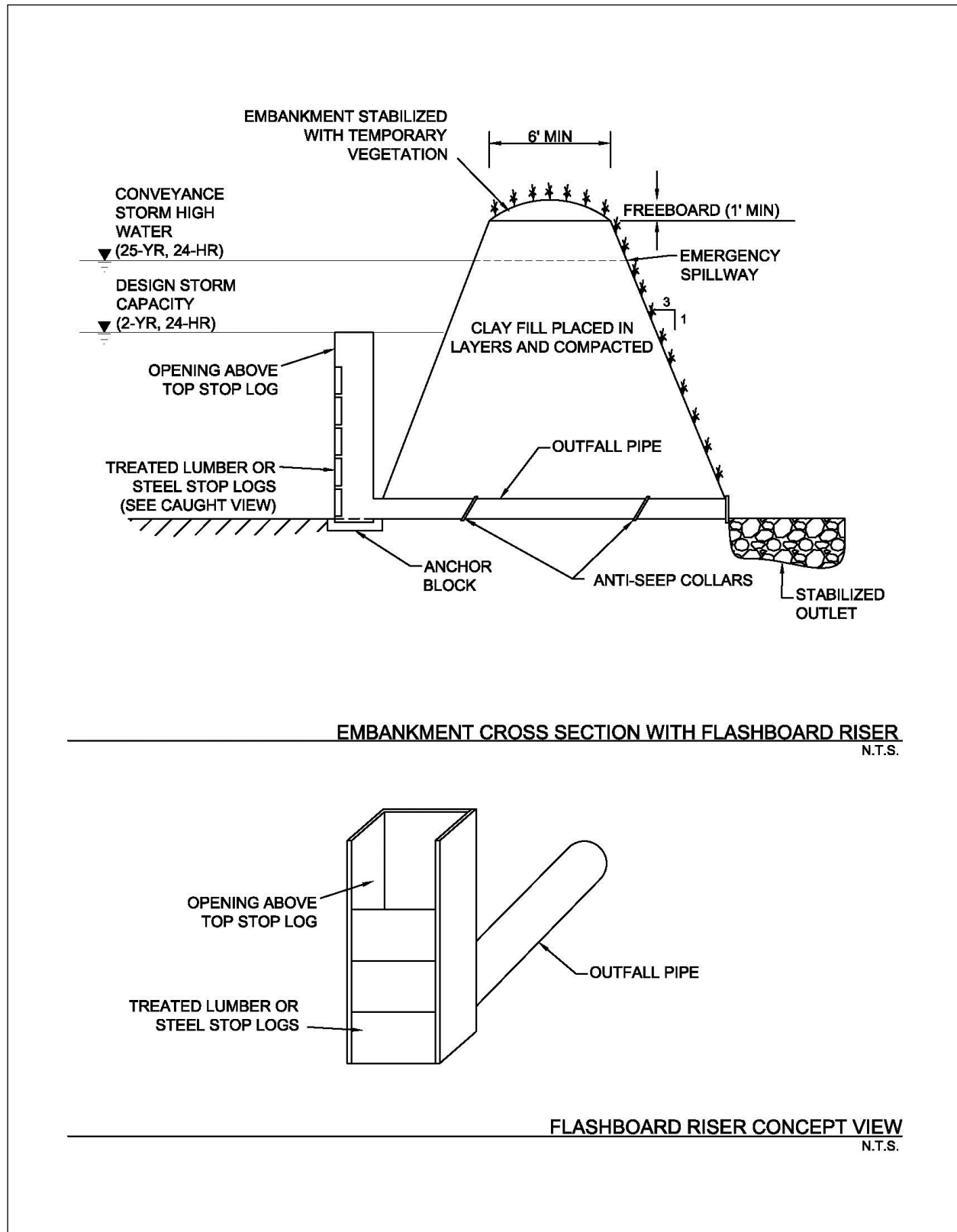

Figure 3.21 Schematics of Basin Embankment with Flashboard Riser

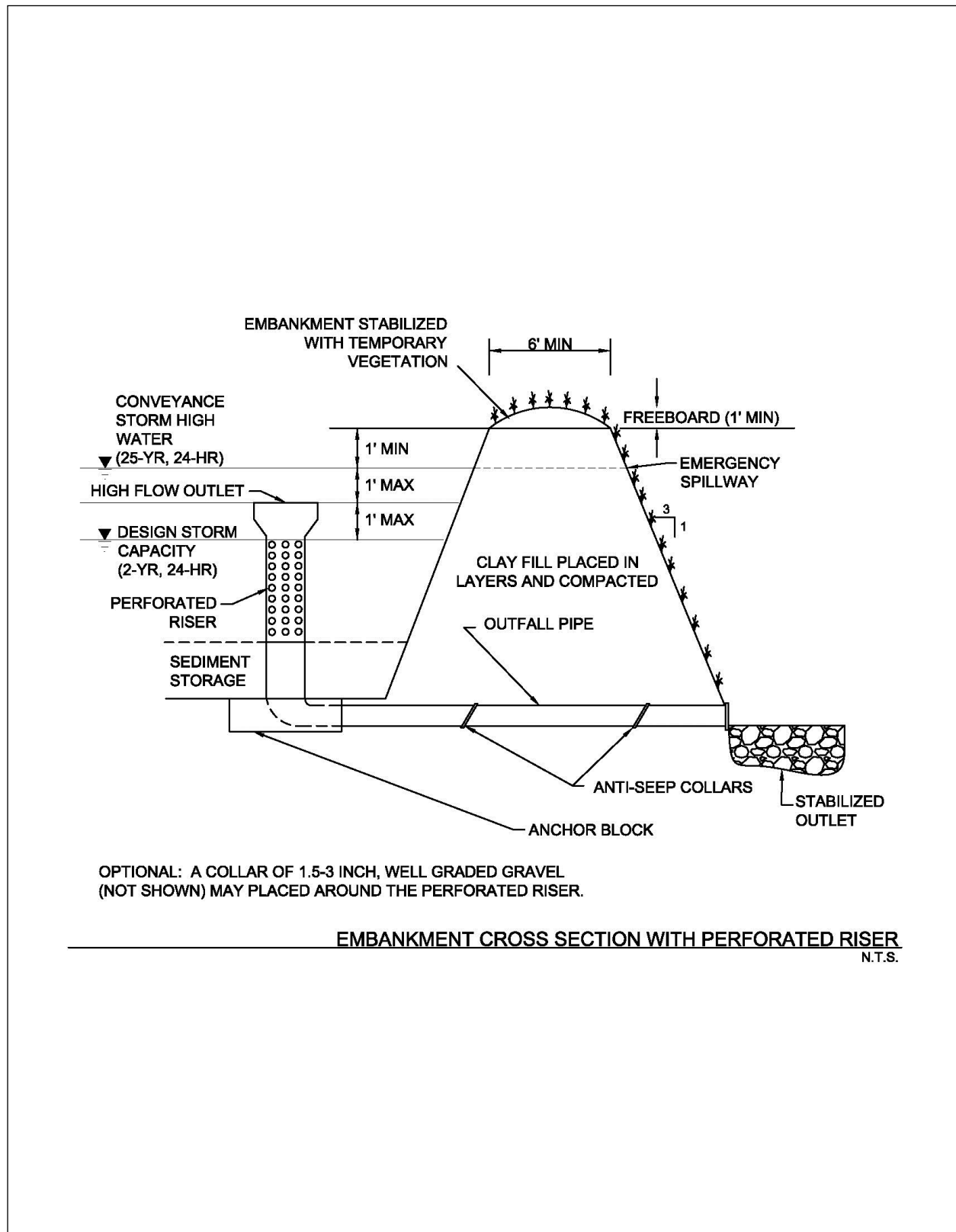

Figure 3.22 Schematic of Basin Embankment with Perforated Riser

3.9.7 Design Procedures

The following procedures provide a step-by-step method for the design of a temporary sediment basin that is smaller than the TCEQ thresholds for state requirements to apply. Criteria in *Section 3.8 of the iSWM Criteria Manual* should be used for the design of permanent basins (dry detention/extended dry detention) and stormwater ponds. *Section 3.9.8 Design Form* should be used to document the design values calculated for the temporary sediment basin.

These design procedures are provided as an example of the steps required to design a temporary sediment basin and are based on a specific type of primary outlet. When designing a sediment basin for a construction site, it's the engineer's responsibility to select the type of outlet that is appropriate based on criteria in the preceding sections and to modify the following procedures as needed to use appropriate calculations for the selected outlet, particularly in Steps 12, 13, and 14.

Step 1 Determine the required basin volume.

The basin volume shall be the calculated volume of runoff from the temporary control design storm (2-year, 24-hour) from each disturbed acre draining to the basin. When rainfall data is not available, a design volume of 3600 cubic feet of storage per acre drained may be used.

For a natural basin, the storage volume may be approximated as follows:

$$V_1 = 0.4 \times A_1 \times D_1 \quad (3.2)$$

where:

V_1 = the storage volume in cubic feet

A_1 = the surface area of the flooded area at the crest of the basin outlet, in square feet

D_1 = the maximum depth in feet, measured from the low point in the basin to the crest of the basin riser

Note 1: The volumes may be computed from more precise contour information or other suitable methods.

Note 2: Conversion between cubic feet and cubic yards is as follows:

$$\text{Number of cubic feet} \times 0.037 = \text{number of cubic yards}$$

If the volume of the basin is inadequate or embankment height becomes excessive, pursue the use of excavation to obtain the required volume.

Step 2 Determine the basin shape.

The shape of the basin must be such that the length-to-width ratio is at least 4 to 1 according to the following equation:

$$\text{Length-to-width Ratio} = \frac{L}{W_e} \quad (3.3)$$

where:

W_e = A/L = the effective width

A = the surface area of the normal pool

L = the length of the flow path from the inflow to the outflow. If there is more than one inflow point, any inflow that carries more than 30 percent of the peak rate of inflow must meet these criteria.

The correct basin length can be obtained by proper site selection, excavation, or the use of baffles. Baffles increase the flow length by interrupting flow and directing it through the basin in a circuitous path to prevent short-circuiting. Porous baffles are recommended. Spacing of baffles should be wide enough to not cause a channeling effect within the basin. Analyze the

flow cross section and velocity between baffles to ensure that velocities are not too fast for settling to occur.

Step 3 Design the embankment.

The side slopes of the embankment should be 3:1 or flatter.

Top width shall be determined by the engineer based on the total height of the embankment.

The area under the embankment should be cleared, grubbed, and stripped of topsoil to remove trees, vegetation, roots, or other objectionable materials. The pool area should also be cleared of all brush and trees.

The embankment fill material should be clay soil from an approved borrow area. It should be clean soil, free from roots, woody vegetation, oversized stones, and rocks.

Step 4 Select the type(s) of outlet(s).

The outlets for the basin may consist of a combination of a primary outlet and emergency spillway or a primary outlet alone. In either case, the outlet(s) must pass the peak runoff expected from the drainage area for the conveyance storm (25-year, 24-hour) without damage to the embankment, structures, or basin.

Step 5 Determine whether the basin will have a separate emergency spillway.

A side channel emergency spillway is required for sediment basins receiving stormwater from more than 10 acres.

Step 6 Determine the elevation of the crest of the basin outlet riser for the required volume.

Step 7 Estimate the elevation of the conveyance storm and the required height of the dam.

- (a) If an emergency spillway is included, the crest of the basin outlet riser must be at least 1.0 foot below the crest of the emergency spillway.
- (b) If an emergency spillway is included, the elevation of the peak flow through the emergency spillway (which will be the design high water for the conveyance storm) must be at least 1.0 foot below the top of embankment.
- (c) If an emergency spillway is not included, the crest of the basin outlet riser must be at least 3 feet below the top of the embankment.
- (d) If an emergency spillway is not included, the elevation of the design high water for the conveyance storm must be 2.0 feet below the top of the embankment.

Step 8 Determine the peak rate of runoff for a 25-year storm.

Using SCS TR 55 Urban Hydrology for Small Watersheds or other methods, determine the peak rate of runoff expected from the drainage area of the basin for the conveyance storm. The "C" factor or "CN" value used in the runoff calculation should be derived from analysis of the contributing drainage area at the peak of land disturbance (condition which will create greatest peak runoff).

Step 9 Design the basin outlet.

- (a) If an emergency spillway is included, the basin outfall must at least pass the peak rate of runoff from the basin drainage area for the temporary control design storm (2-year, 24-hour).

Q_p = the 2-year peak rate of runoff.

- (b) If an emergency spillway is not included, the basin outfall must pass the peak rate of runoff from the basin drainage area for the conveyance storm (25-year, 24-hour).

Q_{25} = the 25-year peak rate of runoff.

- (c) Refer to Figure 3.23, where h is the difference between the elevation of the crest of the basin outlet riser and the elevation of the crest of the emergency spillway.
- (d) Enter Figure 3.24 with Q_p . Choose the smallest riser which will pass the required flow with the available head, h .
- (e) Refer to Figure 3.23, where H is the difference in elevation of the centerline of the outlet of the outfall and the crest of the emergency spillway. L is the length of the barrel through the embankment.
- (f) Enter Table 3.5 or Table 3.6 with H . Choose the smallest size outlet that will pass the flow provided by the riser. If L is other than 70 feet, make the necessary correction.
- (g) The basin riser shall consist of a solid (non-perforated), vertical pipe or box of corrugated metal joined by a watertight connection to a horizontal pipe (outfall) extending through the embankment and discharging beyond the downstream toe of the fill. Another approach is to utilize a perforated vertical riser section surrounded by filter stone.
- (h) The basin outfall, which extends through the embankment, shall be designed to carry the flow provided by the riser with the water level at the crest of the emergency spillway. The connection between the riser and the outfall must be watertight. The outlet of the outfall must be protected to prevent erosion or scour of downstream areas.
- (i) Weirs, skimmers and other types of outlets may be used if accompanied with appropriate calculations.

Step 10 Design the emergency spillway.

- (a) The emergency spillway must pass the remainder of the 25-year peak rate of runoff not carried by the basin outlet.
- (b) Compute: $Q_e = Q_{25} - Q_p$
- (c) Refer to Figure 3.25 and Table 3.7.
- (d) Determine approximate permissible values for b , the bottom width; s , the slope of the exit channel; and X , minimum length of the exit channel.
- (e) Enter Table 3.7 and choose the exit channel cross-section which passes the required flow and meets the other constraints of the site.
- (f) Notes:
 - 1. The maximum permissible velocity for vegetated waterways must be considered when designing an exit channel.
 - 2. For a given H_p , a decrease in the exit slope from S as given in the table decreases spillway discharge, but increasing the exit slope from S does not increase discharge. If an exit slope (S_e) steeper than S is used, then the exit should be considered an open channel and analyzed using the Manning's Equation.
 - 3. Data to the right of heavy vertical lines should be used with caution, as the resulting sections will be either poorly proportioned or have excessive velocities.
- (g) The emergency spillway should not be constructed over fill material.
- (h) The emergency spillway should be stabilized with rock riprap or temporary vegetation upon completion of the basin.

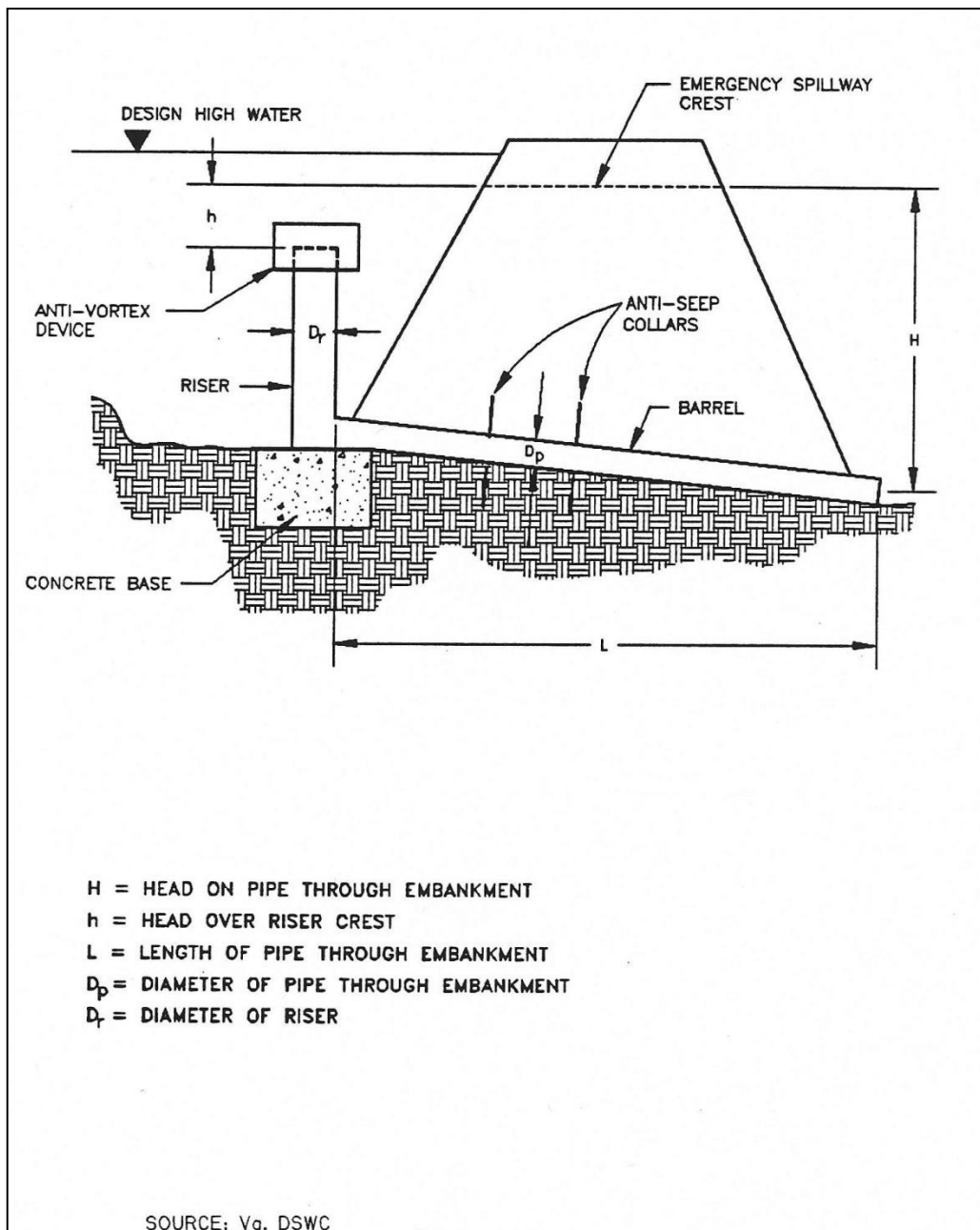

Figure 3.23 Example of Basin Outlet Design

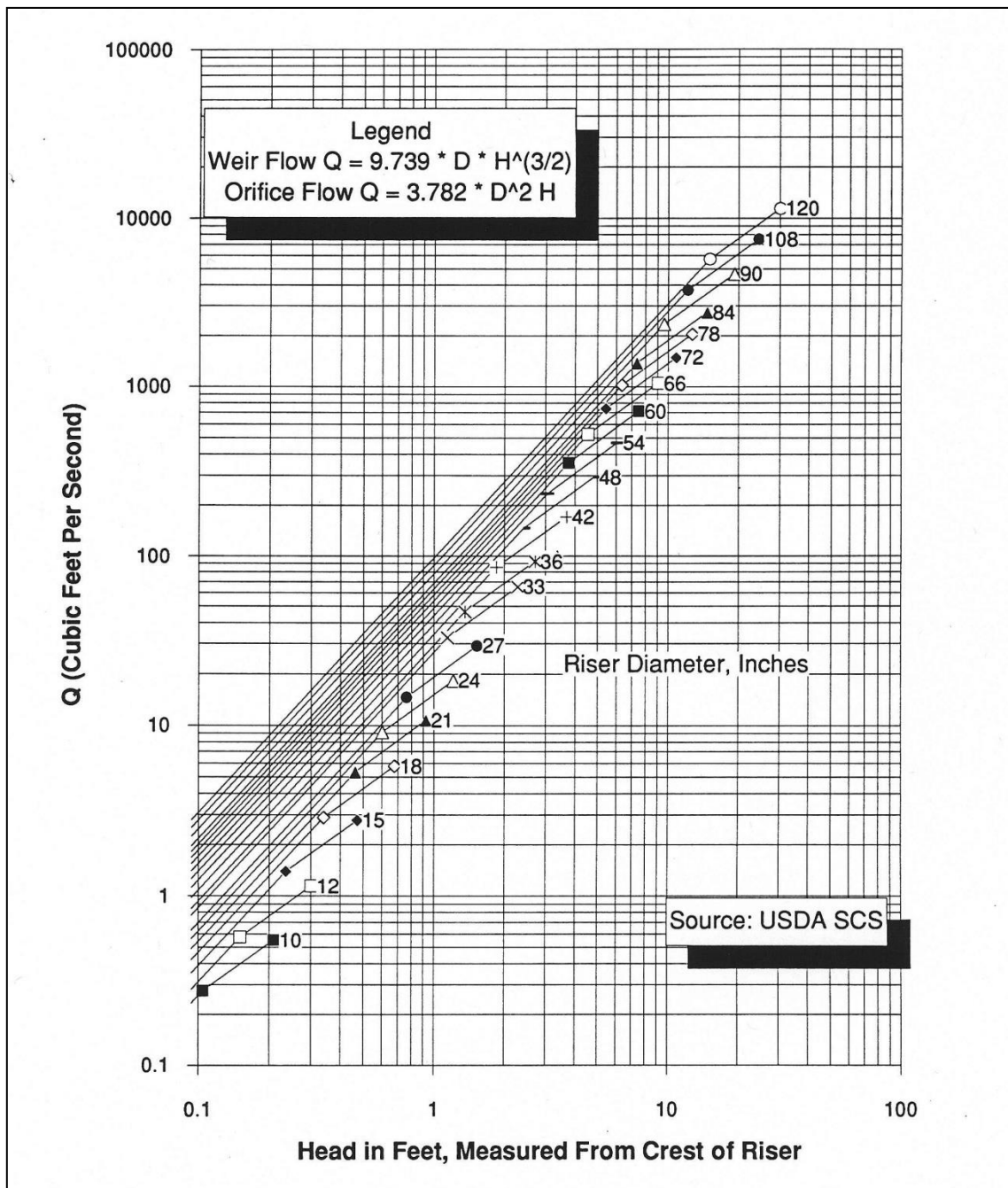

Figure 3.24 Riser Inflow Curves for Basin Outlet Design

Table 3.5 Pipe Flow Chart, n=0.013

For Reinforced Concrete Pipe Inlet Km = Ke + Kb =0.65 and 70 Feet of Reinforced Concrete Pipe Conduit (Full Flow Assumed)
 Note: Correction Factors for pipe lengths other than 70 feet

Head (In feet)	Pipe Diameter in Inches																	
	12	15	18	21	24	30	36	42	48	54	60	66	72	78	84	90	96	102
1	3.22	5.44	8.29	11.8	15.9	26	38.6	53.8	71.4	91.5	114	139	167	197	229	264	302	342
2	4.55	7.69	11.7	16.7	22.5	36.8	54.6	76	101	129	161	197	236	278	324	374	427	483
3	5.57	9.42	14.4	20.4	27.5	45	66.9	93.1	124	159	198	241	289	341	397	458	523	592
4	6.43	10.9	16.6	23.5	31.8	52	77.3	108	143	183	228	278	334	394	459	529	604	683
5	7.19	12.2	18.5	26.3	35.5	58.1	86.4	120	160	205	255	311	373	440	513	591	675	764
6	7.88	13.3	20.3	28.8	38.9	63.7	94.6	132	175	224	280	341	409	482	562	647	739	837
7	8.51	14.4	21.9	31.1	42	68.8	102	142	189	242	302	368	441	521	607	699	798	904
8	9.1	15.4	23.5	33.3	44.9	73.5	109	152	202	259	323	394	472	557	648	748	854	966
9	9.65	16.3	24.9	35.3	47.7	78	116	161	214	275	342	418	500	590	688	793	905	1025
10	10.2	17.2	26.2	37.2	50.2	82.2	122	170	226	289	361	440	527	622	725	836	954	1080
11	10.7	18	27.5	39	52.7	86.2	128	178	237	304	379	462	553	653	761	877	1001	1133
12	11.1	18.9	28.7	40.8	55	90.1	134	186	247	317	395	482	578	682	794	916	1045	1184
13	11.6	19.6	29.9	42.4	57.3	93.7	139	194	257	330	411	502	601	710	827	953	1088	1232
14	12	20.4	31	44.1	59.4	97.3	145	201	267	342	427	521	624	736	858	989	1129	1278
15	12.5	21.1	32.1	45.6	61.5	101	150	208	277	354	442	539	646	762	888	1024	1169	1323
16	12.9	21.8	33.2	47.1	63.5	104	155	215	286	366	457	557	667	787	917	1057	1207	1367
17	13.3	22.4	34.2	48.5	65.5	107	159	222	294	377	471	574	688	812	946	1090	1244	1409
18	13.7	23.1	35.2	49.9	67.4	110	164	228	303	388	484	591	708	835	973	1121	1280	1450
19	14	23.7	36.1	51.3	69.2	113	168	234	311	399	497	607	727	858	1000	1152	1315	1489
20	14.4	24.3	37.1	52.6	71	116	173	240	319	409	510	623	746	880	1026	1182	1350	1528
21	14.7	24.9	38	53.9	72.8	119	177	246	327	419	523	638	764	902	1051	1211	1383	1566
22	15.1	25.5	38.9	55.2	74.5	122	181	252	335	429	535	653	782	923	1076	1240	1415	1603
23	15.4	26.1	39.8	56.5	76.2	125	186	258	342	439	547	668	800	944	1100	1268	1447	1639
24	15.8	26.7	40.6	57.7	77.8	127	189	263	350	448	559	682	817	964	1123	1295	1478	1674
25	16.1	27.2	41.5	58.9	79.4	130	193	269	357	458	571	696	834	984	1147	1322	1509	1708
26	16.4	27.7	42.3	60	81	133	197	274	364	467	582	710	850	1004	1169	1348	1539	1742
27	16.7	28.3	43.1	61.2	82.5	135	201	279	371	476	593	723	867	1023	1192	1373	1568	1775
28	17	28.8	43.9	62.3	84.1	138	204	285	378	484	604	737	883	1041	1214	1399	1597	1808
29	17.3	29.3	44.7	63.4	85.5	140	208	290	384	493	615	750	898	1060	1235	1423	1625	1840
30	17.6	29.8	45.4	64.5	87	142	212	294	391	501	625	763	913	1078	1256	1448	1653	1871
Correction Factors for Other Pipe Lengths																		
20	1.3	1.24	1.21	1.18	1.15	1.12	1.1	1.08	1.07	1.06	1.05	1.05	1.04	1.04	1.03	1.03	1.03	1.03
30	1.22	1.18	1.15	1.13	1.12	1.09	1.08	1.06	1.05	1.04	1.03	1.03	1.03	1.03	1.02	1.02	1.02	1.02
40	1.15	1.13	1.11	1.1	1.08	1.07	1.05	1.04	1.03	1.03	1.03	1.02	1.02	1.02	1.01	1.01	1.01	1.01
50	1.09	1.08	1.07	1.06	1.05	1.04	1.04	1.03	1.03	1.02	1.02	1.02	1.02	1.01	1.01	1.01	1.01	1.01
60	1.04	1.04	1.03	1.03	1.03	1.02	1.02	1.02	1.01	1.01	1.01	1.01	1.01	1.01	1.01	1.01	1.01	1.01
70	1	1	1	1	1	1	1	1	1	1	1	1	1	1	1	1	1	1
80	0.96	0.97	0.97	0.97	0.98	0.98	0.98	0.99	0.99	0.99	0.99	0.99	0.99	0.99	0.99	0.99	0.99	0.99
90	0.93	0.94	0.94	0.95	0.95	0.96	0.97	0.97	0.98	0.98	0.98	0.98	0.98	0.98	0.99	0.99	0.99	0.99
100	0.9	0.91	0.92	0.93	0.93	0.95	0.95	0.96	0.97	0.97	0.97	0.98	0.98	0.98	0.98	0.98	0.98	0.99
120	0.84	0.86	0.87	0.89	0.9	0.91	0.93	0.94	0.94	0.95	0.96	0.96	0.96	0.97	0.97	0.97	0.97	0.98
140	0.8	0.82	0.83	0.85	0.86	0.88	0.9	0.91	0.92	0.93	0.94	0.94	0.95	0.95	0.96	0.96	0.96	0.97
160	0.76	0.78	0.8	0.82	0.83	0.86	0.88	0.89	0.9	0.91	0.92	0.93	0.94	0.94	0.95	0.95	0.95	0.96

Source: USDA SCS

Table 3.6 Pipe Flow Chart, n=0.025

For Corrugated Metal Pipe Inlet Km = Ke + Kb = 0.65 and 70 Feet of Corrugated Metal Pipe Conduit (Full Flow Assumed)
 Note: Correction Factors for pipe lengths other than 70 feet

Head (in feet)	Pipe Diameter in Inches															Correction Factors for Other Pipe Lengths					
	6	8	10	12	15	18	21	24	30	36	42	48	54	60	66		72	78	84	90	96
1	0.33	0.7	1.25	1.98	3.48	5.47	7.99	11	18.8	28.8	41.1	55.7	72.6	91.8	113	137	163	191	222	255	290
2	0.47	0.99	1.76	2.8	4.92	7.74	11.3	15.6	26.6	40.8	58.2	78.8	103	130	160	194	231	271	314	360	410
3	0.58	1.22	2.16	3.43	6.02	9.48	13.8	19.1	32.6	49.9	71.2	96.5	126	159	196	237	282	331	384	441	502
4	0.67	1.4	2.49	3.97	6.96	10.9	16	22.1	37.6	57.7	82.3	111	145	184	226	274	326	383	444	510	580
5	0.74	1.57	2.79	4.43	7.78	12.2	17.9	24.7	42.1	64.5	92	125	162	205	253	306	365	428	496	570	648
6	0.82	1.72	3.05	4.86	8.52	13.4	19.6	27	46.1	70.6	101	136	178	225	277	336	399	469	544	624	710
7	0.88	1.86	3.3	5.25	9.2	14.5	21.1	29.2	49.8	76.3	109	147	192	243	300	362	431	506	587	674	767
8	0.94	1.99	3.53	5.61	9.84	15.5	22.6	31.2	53.2	81.5	116	158	205	260	320	388	461	541	628	721	820
9	1	2.11	3.74	5.95	10.4	16.4	24	33.1	56.4	86.5	123	167	218	275	340	411	489	574	666	764	870
10	1.05	2.22	3.94	6.27	11	17.3	25.3	34.9	59.5	91.2	130	176	230	290	358	433	516	605	702	806	917
11	1.1	2.33	4.13	6.58	11.5	18.2	26.5	36.6	62.4	95.6	136	185	241	304	376	454	541	635	736	845	962
12	1.15	2.43	4.32	6.87	12.1	19	27.7	38.2	65.2	99.9	142	193	252	318	392	475	565	663	769	883	1004
13	1.2	2.53	4.49	7.15	12.6	19.7	28.8	39.8	67.8	104	148	201	262	331	408	494	588	690	800	919	1045
14	1.25	2.63	4.66	7.42	13	20.5	29.9	41.3	70.4	108	154	208	272	343	424	513	610	716	830	953	1085
15	1.29	2.72	4.83	7.68	13.5	21.2	30.9	42.8	72.8	112	159	216	281	355	439	531	631	741	860	987	1123
16	1.33	2.81	4.99	7.93	13.9	21.9	32	44.2	75.2	115	165	223	290	367	453	548	652	765	888	1019	1160
17	1.37	2.9	5.14	8.18	14.3	22.6	32.9	45.5	77.5	119	170	230	300	378	467	565	672	789	915	1051	1195
18	1.41	2.98	5.29	8.41	14.8	23.2	33.9	46.8	79.8	120	174	236	308	389	480	581	692	812	942	1081	1230
19	1.45	3.06	5.43	8.64	15.2	23.9	34.8	48.1	82	126	179	243	316	400	494	597	711	834	967	1111	1264
20	1.49	3.14	5.57	8.87	15.6	24.5	35.7	49.4	84.1	129	184	249	325	410	506	613	729	856	993	1139	1297
21	1.53	3.22	5.71	9.09	15.9	25.1	36.6	50.6	86.2	132	188	255	333	421	519	628	747	877	1017	1168	1329
22	1.56	3.29	5.85	9.3	16.3	25.7	37.5	51.8	88.2	135	193	261	341	430	531	643	765	898	1041	1195	1360
23	1.6	3.37	5.98	9.51	16.7	26.2	38.3	53	90.2	138	197	267	348	440	543	657	782	918	1064	1222	1390
24	1.63	3.44	6.11	9.72	17	26.8	39.1	54.1	92.1	141	201	273	356	450	555	671	799	937	1087	1248	1420
25	1.66	3.51	6.23	9.92	17.4	27.4	39.9	55.2	94	144	206	279	363	459	566	685	815	957	1110	1274	1450
26	1.7	3.58	6.36	10.1	17.7	27.9	40.7	56.3	95.9	147	210	284	370	468	577	699	831	976	1132	1299	1478
27	1.73	3.65	6.48	10.3	18.1	28.4	41.5	57.4	97.7	150	214	290	377	477	588	712	847	994	1153	1324	1507
28	1.76	3.72	6.6	10.5	18.4	29	42.3	58.4	99.5	153	218	295	384	486	599	725	863	1013	1174	1348	1534
29	1.79	3.78	6.71	10.7	18.7	29.5	43	59.5	101	155	221	300	391	494	610	738	878	1030	1195	1372	1561
30	1.82	3.85	6.83	10.9	19.1	30	43.7	60.5	103	158	225	305	398	503	620	750	893	1048	1216	1396	1588
20	1.69	1.63	1.58	1.53	1.47	1.42	1.37	1.34	1.28	1.24	1.2	1.18	1.16	1.14	1.13	1.11	1.1	1.1	1.09	1.08	1.08
30	1.44	1.41	1.39	1.36	1.32	1.29	1.27	1.24	1.21	1.18	1.15	1.13	1.12	1.11	1.1	1.09	1.08	1.07	1.07	1.06	1.06
40	1.28	1.27	1.25	1.23	1.21	1.2	1.18	1.17	1.14	1.12	1.11	1.1	1.09	1.08	1.07	1.06	1.06	1.05	1.05	1.05	1.04
50	1.16	1.16	1.15	1.14	1.13	1.12	1.11	1.1	1.09	1.08	1.07	1.06	1.06	1.05	1.05	1.04	1.04	1.04	1.03	1.03	1.03
60	1.07	1.07	1.07	1.06	1.06	1.05	1.05	1.05	1.04	1.04	1.03	1.03	1.03	1.02	1.02	1.02	1.02	1.02	1.02	1.02	1.01
70	1	1	1	1	1	1	1	1	1	1	1	1	1	1	1	1	1	1	1	1	1
80	0.94	0.94	0.95	0.95	0.95	0.95	0.96	0.96	0.96	0.97	0.97	0.97	0.98	0.98	0.98	0.98	0.98	0.98	0.99	0.99	0.99
90	0.89	0.89	0.9	0.9	0.91	0.91	0.92	0.92	0.93	0.94	0.94	0.94	0.95	0.95	0.96	0.96	0.97	0.97	0.97	0.97	0.97
100	0.85	0.85	0.86	0.86	0.87	0.88	0.89	0.89	0.9	0.91	0.92	0.93	0.93	0.94	0.94	0.95	0.95	0.95	0.96	0.96	0.96
120	0.78	0.79	0.79	0.8	0.81	0.82	0.83	0.83	0.85	0.86	0.87	0.89	0.89	0.9	0.91	0.91	0.92	0.93	0.93	0.94	0.94
140	0.72	0.73	0.74	0.75	0.76	0.77	0.78	0.79	0.81	0.82	0.84	0.85	0.86	0.87	0.88	0.88	0.89	0.9	0.91	0.91	0.92
160	0.68	0.69	0.69	0.7	0.71	0.73	0.74	0.75	0.77	0.79	0.8	0.82	0.83	0.84	0.85	0.85	0.87	0.88	0.89	0.89	0.91

Source: USDA SCS

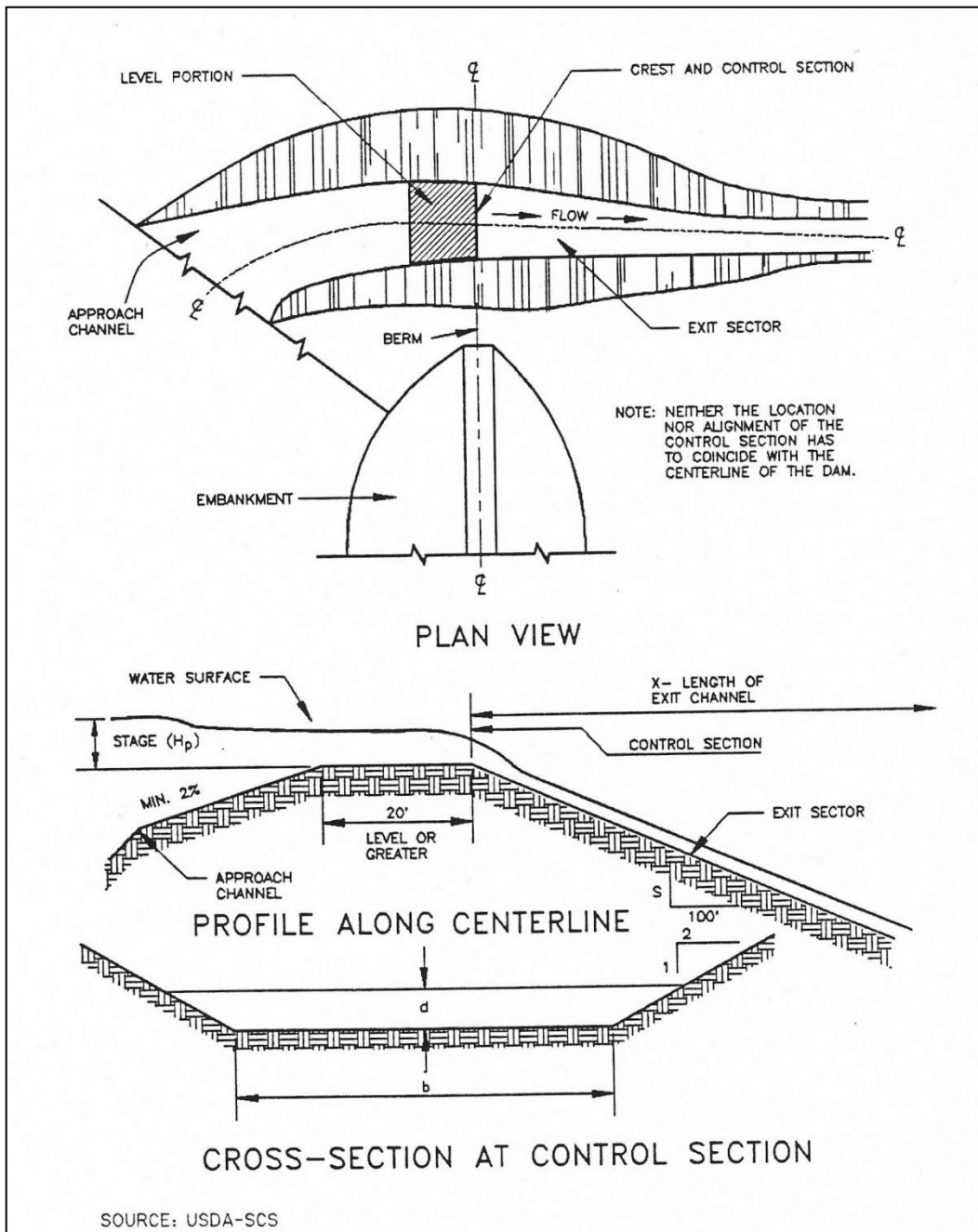

Figure 3.25 Example of Excavated Earth Spillway Design

Table 3.7 Design Data for Earth Spillways

Stage (Hp) In Feet	Spillway Variables	Bottom Width (b) in Feet																
		8	10	12	14	16	18	20	22	24	26	28	30	32	34	36	38	40
0.5	Q	6	7	8	10	11	13	14	15	17	18	20	21	22	24	25	27	28
	V	2.7	2.7	2.7	2.7	2.7	2.7	2.7	2.7	2.7	2.7	2.7	2.7	2.7	2.7	2.7	2.7	2.7
	S	3.9	3.9	3.9	3.9	3.8	3.8	3.8	3.8	3.8	3.8	3.8	3.8	3.8	3.8	3.8	3.8	3.8
	X	32	33	33	33	33	33	33	33	33	33	33	33	33	33	33	33	33
0.6	Q	8	10	12	14	16	18	20	22	24	26	28	30	32	34	35	37	39
	V	3	3	3	3	3	3	3	3	3	3	3	3	3	3	3	3	3
	S	3.7	3.7	3.7	3.7	3.6	3.7	3.6	3.6	3.6	3.6	3.6	3.6	3.6	3.6	3.6	3.6	3.6
	X	36	36	36	36	36	36	37	37	37	37	37	37	37	37	37	37	37
0.7	Q	11	13	16	18	20	23	25	28	30	33	35	38	41	43	44	46	48
	V	3.2	3.2	3.3	3.3	3.3	3.3	3.3	3.3	3.3	3.3	3.3	3.3	3.3	3.3	3.3	3.3	3.3
	S	3.5	3.5	3.4	3.4	3.4	3.4	3.4	3.4	3.4	3.4	3.4	3.4	3.4	3.4	3.4	3.4	3.4
	X	39	40	40	40	41	41	41	41	41	41	41	41	41	41	41	41	41
0.8	Q	13	16	19	22	26	29	32	35	38	42	45	46	48	51	54	57	60
	V	3.5	3.5	3.5	3.6	3.6	3.6	3.6	3.6	3.6	3.6	3.6	3.6	3.6	3.6	3.6	3.6	3.6
	S	3.3	3.3	3.3	3.2	3.2	3.2	3.2	3.2	3.2	3.2	3.2	3.2	3.2	3.2	3.2	3.2	3.2
	X	44	44	44	44	44	45	45	45	45	45	45	45	45	45	45	45	45
0.9	Q	17	20	24	28	32	35	39	43	47	51	53	57	60	64	68	71	75
	V	3.7	3.8	3.8	3.8	3.8	3.8	3.8	3.8	3.8	3.8	3.8	3.8	3.8	3.8	3.8	3.8	3.8
	S	3.2	3.1	3.1	3.1	3.1	3.1	3.1	3.1	3.1	3.1	3.1	3.1	3.1	3.1	3.1	3.1	3.1
	X	47	47	48	48	48	48	48	48	48	48	49	49	49	49	49	49	49
1	Q	20	24	29	33	38	42	47	51	56	61	63	68	72	77	81	86	90
	V	4	4	4	4	4	4	4	4	4	4	4	4	4	4	4	4	4
	S	3.1	3	3	3	3	3	3	3	3	3	3	3	3	3	3	3	3
	X	51	51	51	51	52	52	52	52	52	52	52	52	52	52	52	52	52
1.1	Q	23	28	34	39	44	49	54	60	65	70	74	79	84	89	95	100	105
	V	4.2	4.2	4.2	4.3	4.3	4.3	4.3	4.3	4.3	4.3	4.3	4.3	4.3	4.3	4.3	4.3	4.3
	S	2.9	2.9	2.9	2.9	2.9	2.9	2.9	2.9	2.9	2.8	2.8	2.8	2.8	2.8	2.8	2.8	2.8
	X	55	55	55	55	55	55	55	56	56	56	56	56	56	56	56	56	56
1.2	Q	28	33	40	45	51	58	64	69	76	80	86	92	98	104	110	116	122
	V	4.4	4.4	4.4	4.4	4.4	4.5	4.5	4.5	4.5	4.5	4.5	4.5	4.5	4.5	4.5	4.5	4.5
	S	2.9	2.9	2.8	2.8	2.8	2.8	2.8	2.8	2.8	2.8	2.8	2.8	2.8	2.8	2.8	2.8	2.8
	X	58	58	59	59	59	59	59	59	60	60	60	60	60	60	60	60	60
1.3	Q	32	38	46	53	58	65	73	80	86	91	99	106	112	119	125	133	140
	V	4.5	4.6	4.6	4.6	4.6	4.6	4.7	4.7	4.7	4.7	4.7	4.7	4.7	4.7	4.7	4.7	4.7
	S	2.8	2.8	2.8	2.7	2.7	2.7	2.7	2.7	2.7	2.7	2.7	2.7	2.7	2.7	2.7	2.7	2.7
	X	62	62	62	63	63	63	63	63	63	63	63	64	64	64	64	64	64
1.4	Q	37	44	51	59	66	74	82	90	96	103	111	119	127	134	143	150	158
	V	4.8	4.8	4.8	4.8	4.8	4.8	4.8	4.8	4.8	4.9	4.9	4.9	4.9	4.9	4.9	4.9	4.9
	S	2.8	2.7	2.7	2.7	2.7	2.7	2.7	2.6	2.6	2.6	2.6	2.6	2.6	2.6	2.6	2.6	2.6
	X	65	66	66	66	66	67	67	67	67	67	67	68	68	68	68	68	69

Table 3.7 Design Data for Earth Spillways (continued)

Stage (Hp) In Feet	Spillway Variables	Bottom Width (b) In Feet																
		8	10	12	14	16	18	20	22	24	26	28	30	32	34	36	38	40
1.5	Q	41	50	58	66	75	85	92	101	108	116	125	133	142	150	160	169	178
	V	4.8	4.9	5	5	5	5	5	5	5	5	5	5	5	5	5.1	5.1	5.1
	S	2.7	2.7	2.6	2.6	2.6	2.6	2.6	2.6	2.6	2.6	2.6	2.6	2.6	2.6	2.5	2.5	2.5
	X	69	69	70	70	71	71	71	71	71	71	71	71	72	72	72	72	72
1.6	Q	46	56	65	75	84	94	104	112	122	132	142	149	158	168	178	187	197
	V	5	5.1	5.1	5.1	5.1	5.2	5.2	5.2	5.2	5.2	5.2	5.2	5.2	5.2	5.2	5.2	5.2
	S	2.6	2.6	2.6	2.6	2.5	2.5	2.5	2.5	2.5	2.5	2.5	2.5	2.5	2.5	2.5	2.5	2.5
	X	72	74	74	75	75	76	76	76	76	76	76	76	76	76	76	76	76
1.7	Q	52	62	72	83	94	105	115	126	135	145	156	167	175	187	196	206	217
	V	5.2	5.2	5.2	5.3	5.3	5.3	5.3	5.4	5.4	5.4	5.4	5.4	5.4	5.4	5.4	5.4	5.4
	S	2.6	2.6	2.5	2.5	2.5	2.5	2.5	2.5	2.5	2.5	2.5	2.5	2.5	2.5	2.5	2.5	2.5
	X	76	78	79	80	80	80	80	80	80	80	80	80	80	80	80	80	80
1.8	Q	58	69	81	93	104	116	127	138	150	160	171	182	194	204	214	226	233
	V	5.3	5.4	5.4	5.5	5.5	5.5	5.5	5.5	5.5	5.5	5.5	5.6	5.6	5.6	5.6	5.6	5.6
	S	2.5	2.5	2.5	2.5	2.4	2.4	2.4	2.4	2.4	2.4	2.4	2.4	2.4	2.4	2.4	2.4	2.4
	X	80	82	83	84	84	84	84	84	84	84	84	84	84	84	84	84	84
1.9	Q	64	76	88	102	114	127	140	152	164	175	188	201	213	225	235	248	260
	V	5.5	5.5	5.5	5.6	5.6	5.6	5.7	5.7	5.7	5.7	5.7	5.7	5.7	5.7	5.7	5.7	5.7
	S	2.5	2.5	2.5	2.4	2.4	2.4	2.4	2.4	2.4	2.4	2.4	2.4	2.4	2.4	2.4	2.4	2.4
	X	84	85	86	87	88	88	88	88	88	88	88	88	88	88	88	88	88
2	Q	71	83	97	111	125	138	153	164	178	193	204	218	232	245	256	269	283
	V	5.6	5.7	5.7	5.7	5.8	5.8	5.8	5.8	5.8	5.8	5.8	5.9	5.9	5.9	5.9	5.9	5.9
	S	2.5	2.4	2.4	2.4	2.4	2.4	2.4	2.4	2.3	2.3	2.3	2.3	2.3	2.3	2.3	2.3	2.3
	X	88	90	91	91	91	91	92	92	92	92	92	92	92	92	92	92	92
2.1	Q	77	91	107	122	135	149	162	177	192	207	220	234	250	267	276	291	305
	V	5.7	5.8	5.9	5.9	5.9	5.9	5.9	6	6	6	6	6	6	6	6	6	6
	S	2.4	2.4	2.4	2.4	2.4	2.3	2.3	2.3	2.3	2.3	2.3	2.3	2.3	2.3	2.3	2.3	2.3
	X	92	93	95	95	95	95	95	95	95	96	96	96	96	96	96	96	96
2.2	Q	84	100	116	131	146	163	177	194	210	224	238	253	269	288	301	314	330
	V	5.9	5.9	6	6	6	6.1	6.1	6.1	6.1	6.1	6.1	6.1	6.1	6.2	6.2	6.2	6.2
	S	2.4	2.4	2.4	2.3	2.3	2.3	2.3	2.3	2.3	2.3	2.3	2.3	2.3	2.3	2.3	2.3	2.3
	X	96	98	99	99	99	99	99	100	100	100	100	100	100	100	100	100	100
2.3	Q	90	108	124	140	158	175	193	208	226	243	258	275	292	306	323	341	354
	V	6	6.1	6.1	6.1	6.2	6.2	6.2	6.2	6.3	6.3	6.3	6.3	6.3	6.3	6.3	6.3	6.3
	S	2.4	2.4	2.3	2.3	2.3	2.3	2.3	2.3	2.2	2.2	2.2	2.2	2.2	2.2	2.2	2.2	2.2
	X	100	102	102	103	103	103	104	104	104	105	105	105	105	105	105	105	105
2.4	Q	99	116	136	152	170	189	206	224	241	260	275	294	312	327	346	364	378
	V	6.1	6.2	6.2	6.3	6.3	6.3	6.4	6.4	6.4	6.4	6.4	6.4	6.4	6.4	6.4	6.4	6.4
	S	2.3	2.3	2.3	2.3	2.3	2.2	2.2	2.2	2.2	2.2	2.2	2.2	2.2	2.2	2.2	2.2	2.2
	X	105	105	106	107	107	108	108	108	108	109	109	109	109	109	109	109	109

Source: USDA - SCS

Step 11 Re-estimate the elevation of the design high water and the top of the dam based upon the design of the basin outlet and the emergency spillway.

Step 12 Design the anti-vortex device and trash rack.

If an outfall riser is used, an anti-vortex device and trash rack shall be attached to the top of the basin riser to improve the flow of water into the outfall and prevent floating debris from being carried out of the basin.

This design procedure for the anti-vortex device and trash rack refers only to round riser pipes of corrugated metal. There are numerous ways to provide protection for concrete pipe; these include various hoods and grates and rebar configurations which should be a part of project-specific design and will frequently be a part of a permanent structure.

Refer to Figure 3.26 and Table 3.8. Choose cylinder size, support bars, and top requirements from Table 3.8 based on the diameter of the riser pipe.

Step 13 Design the anchoring for the basin outlet.

The basin outlet must be firmly anchored to prevent its floating.

If the riser is over 10 feet high, the forces acting on the spillway must be calculated. A method of anchoring the spillway which provides a safety factor of 1.25 must be used (downward forces = 1.25 x upward forces).

If the riser is 10 feet or less in height, choose one of the two methods in Figure 3.27 to anchor the basin outlet.

Determine the number and spacing of anti-seep collars for the outfall pipe through the embankment.

Step 14 Provide for dewatering.

(a) Use a modified version of the discharge equation for a vertical orifice and a basic equation for the area of a circular orifice.

Naming the variables:

A = flow area of orifice, in square feet

D = diameter of circular orifice, in inches

h = average driving head (maximum possible head measured from radius of orifice to crest of basin outlet divided by 2), in feet

Q = volumetric flow rate through orifice needed to achieve approximate 6-hour drawdown, cubic feet per second

S = total storage available in dry storage area, cubic feet

Q = S/21,600 seconds

(b) An alternative approach for dewatering is the use of a perforated riser (0.75" to 1" diameter holes spaced every 12 inch horizontally and 8 inch vertically) with 1½ inch to 2 inch filter stone stacked around the exterior.

Use S for basin and find Q. Then substitute in calculated Q and find A:

$$A = (0.6) \times \frac{Q}{(64.32 \times \frac{h}{2})} \quad (3.4)$$

Then, substitute in calculated A and find d:

$$d^* = 2 \times \frac{(\underline{A})}{(3.14)} \quad (3.5)$$

Diameter of the dewatering orifice should never be less than 3 inches in order to help prevent clogging by soil or debris.

Flexible tubing should be at least 2 inches larger in diameter than the calculated orifice to promote improved flow characteristics.

Additional design guidance for orifices and perforated risers are in [Section 2.2.2 of the Hydraulics Technical Manual](#).

- (c) If a surface skimmer is used as the basin's primary outlet, it may also be used to dewater the basin. Orifice flowrates for the skimmer will be provided by the manufacturer.

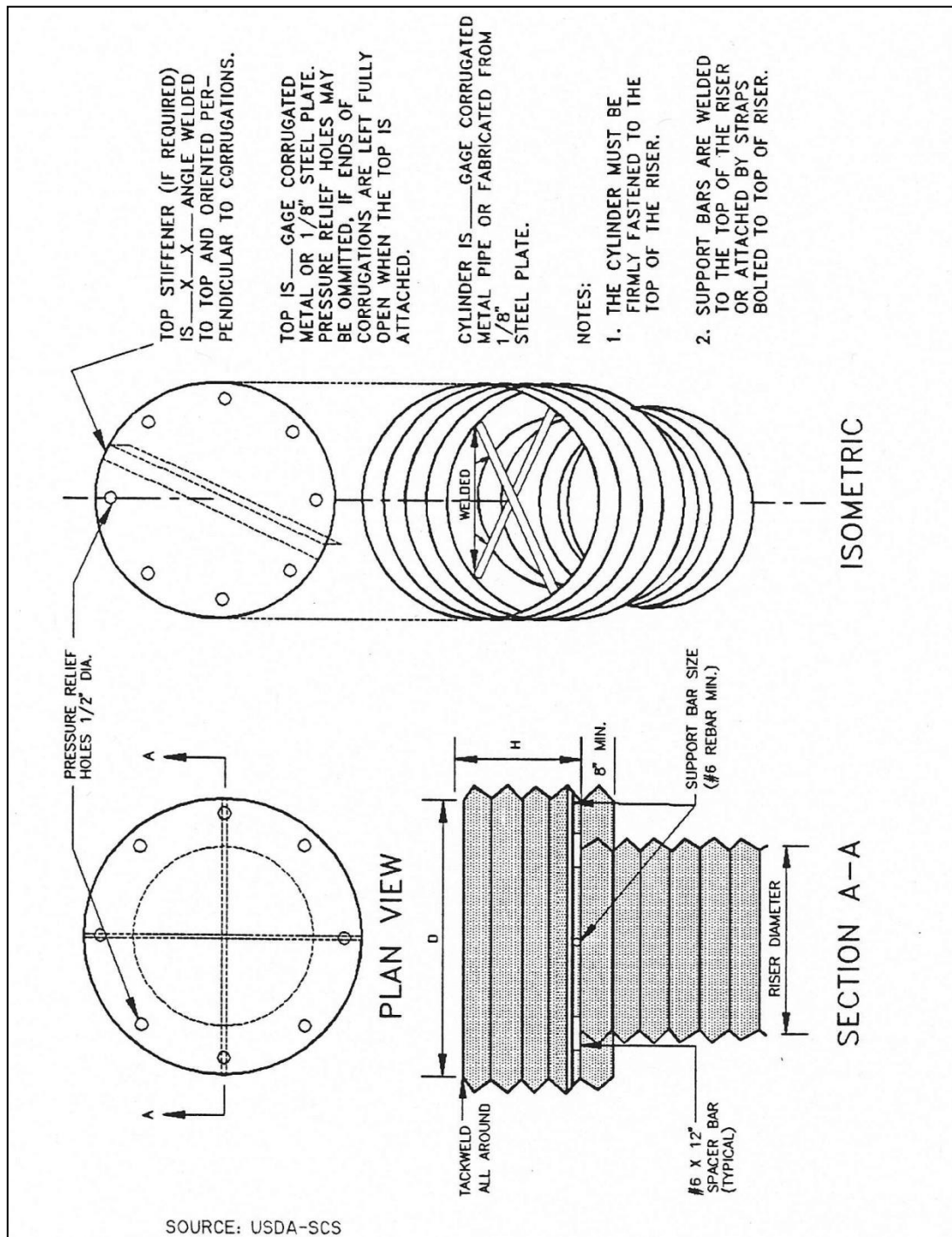

Figure 3.26 Example of Anti-Vortex Design for Corrugated Metal Pipe Riser

Table 3.8 Trash Rack and Anti-Vortex Device Design Table

Riser Diam., in.	Cylinder		Height inches	Minimum Size Support Bar	Minimum Top	
	Diameter inches	Thickness gage			Thickness	Stiffener
12	18	16	6	#6 Rebar or 1 ½ x 1 ½ x 3/16 angle	16 ga. (F&C)	-
15	21	16	7	" "	" "	-
18	27	16	8	" "	" "	-
21	30	16	11	" "	16 ga.(C), 14 ga.(F)	-
24	36	16	13	" "	" "	-
27	42	16	13	" "	" "	-
36	54	14	17	#8 Rebar	14 ga.(C), 12 ga.(F)	-
42	60	16	19	" "	" "	-
48	72	16	21	1 ½" pipe or 1 ½ x 1 ½ x ¼ angle	14 ga.(C), 10 ga.(F)	-
54	78	16	25	" "	" "	-
60	90	14	29	1 ½" pipe or 1 ½ x 1 ½ x ¼ angle	12 ga.(C), 8 ga.(F)	-
66	96	14	33	2" pipe or 2 x 2 x 3/16 angle	12 ga.(C), 8	2 x 2 x ¼ angle
72	102	14	36	" "	" "	2 ½ x 2 ½ x ¼ angle
78	114	14	39	2 ½" pipe or 2 ½ x ¼ angle	" "	" "
84	120	12	42	2 ½" pipe or 2 ½ x 2 ½ x ¼ angle	" "	2 ½ x 2 ½ x 5/16 angle

Note₁: The criterion for sizing the cylinder is that the area between the inside of the cylinder and the outside of the riser is equal to or greater than the area inside the riser. Therefore, the above table is invalid for use with concrete pipe risers.

Note₂: Corrugation for 12"-36" pipe measures 2 ¾ x ½"; for 42"-84" the corrugation measures 5" x 1" or 8" x 1".

Note₃: C = corrugated; F = flat.

Source: Adapted from USDA-SCS and Carl M. Henshaw Drainage Products Information.

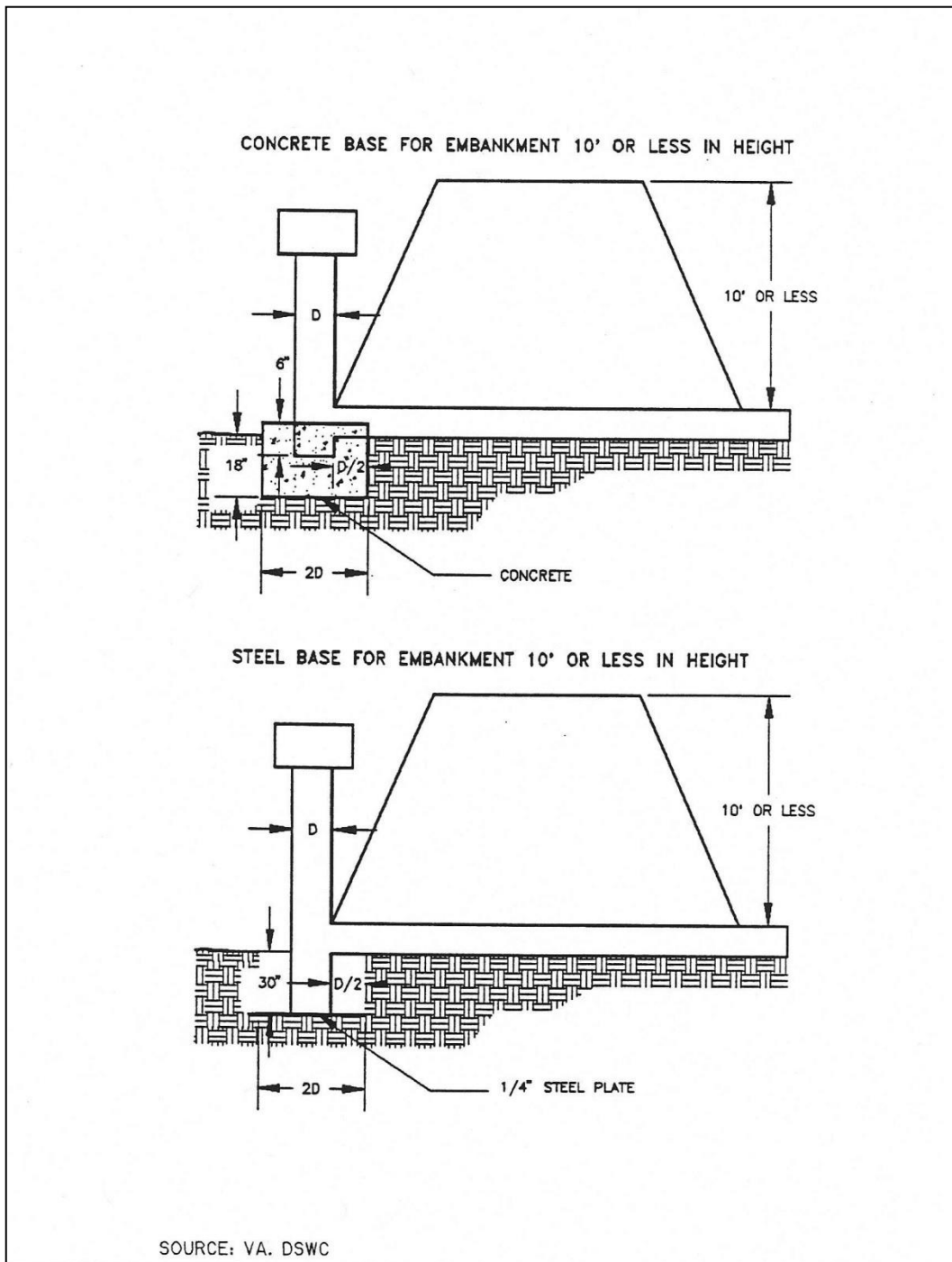

Figure 3.27 Riser Pipe Base Design for Embankment Less Than 10 Feet High

3.9.8 Design Form

Note: This design form is for basins designed with a riser as its primary outlet. It is provided as an example of the type of documentation required for a sediment basin. Different calculations will be needed for other types of outlets.

Project _____

Basin # _____ Location _____

Total area draining to basin: _____ acres.

Total disturbed area draining to basin: _____ acres.

Basin Volume Design

1. Minimum required volume is the lesser of
 - a.) $(3600 \text{ cu. ft.} \times \text{total drainage acres}) / 27 = \text{_____ cu. yds.}$
 - b.) 2 yr, 24 hr storm volume in cubic yards = _____ cu. yds.
2. Total available basin volume at crest of riser* = _____ cu. yds. at elevation _____.
(From Storage - Elevation Curve)

* Minimum = Lesser of 3600 cubic feet/acre of Total Drainage Area or
2yr. 24 hr. storm volume from Disturbed Area drained

3. Excavate _____ cu. yds. to obtain required volume*.
*Elevation corresponding to required volume = invert of the dewatering orifice.
4. Diameter of dewatering orifice = _____ in.
5. Diameter of flexible tubing = _____ in. (diameter of dewatering orifice plus 2 inches).

Preliminary Design Elevations

6. Crest of Riser = _____
Top of Dam = _____
Design High Water = _____
Upstream Toe of Dam = _____

Basin Shape

7. $\frac{\text{Length of Flow}}{\text{Effective Width}} = \frac{L}{We} = \underline{\hspace{2cm}}$

If > 2 , baffles are not required $\underline{\hspace{2cm}}$

If < 2 , baffles are required $\underline{\hspace{2cm}}$

Runoff

8. $Q_2 = \underline{\hspace{2cm}}$ cfs (From TR-55)

9. $Q_{25} = \underline{\hspace{2cm}}$ cfs (From TR-55)

Basin Outlet Design

10. With emergency spillway, required basin outlet capacity $Q_p = Q_2 = \underline{\hspace{2cm}}$ cfs.
(riser and outfall)

Without emergency spillway, required basin outlet capacity $Q_p = Q_{25} = \underline{\hspace{2cm}}$ cfs.
(riser and outfall)

11. With emergency spillway:

Assumed available head (h) = $\underline{\hspace{2cm}}$ ft. (Using Q_2)

$h = \text{Crest of Emergency Spillway Elevation} - \text{Crest of Riser Elevation}$

Without emergency spillway:

$h = \text{Design High Water Elevation} - \text{Crest of Riser Elevation}$

12. Riser diameter (D_r) = $\underline{\hspace{2cm}}$ in. Actual head (h) = $\underline{\hspace{2cm}}$ ft.

(Figure 3.23)

Note: Avoid orifice flow conditions.

13. Barrel length (l) = $\underline{\hspace{2cm}}$ ft.

Head (H) on outfall through embankment = $\underline{\hspace{2cm}}$ ft.

(Figure 3.24)

14. Barrel Diameter = $\underline{\hspace{2cm}}$ in.

(From Table 3.5 [concrete pipe] or Table 3.6 [corrugated pipe]).

15. Trash rack and anti-vortex device

Diameter = _____ inches.

Height = _____ inches.

(From Table 3.8).

Emergency Spillway Design16. Required spillway capacity $Q_e = Q_{25} - Q_p =$ _____ cfs.

17. Bottom width (b) = _____ ft.; the slope of the exit channel(s) = _____ ft./foot; and the minimum length of the exit channel (x) = _____ ft.
(From Figure 3.25 and Table 3.7).

Final Design Elevations

18. Top of Dam = _____

Design High Water = _____

Emergency Spillway Crest = _____

Basin Riser Crest = _____

Dewatering Orifice Invert = _____

Elevation of Upstream Toe of Dam
(if excavation was performed) = _____

3.10 Silt Fence

Sediment Control

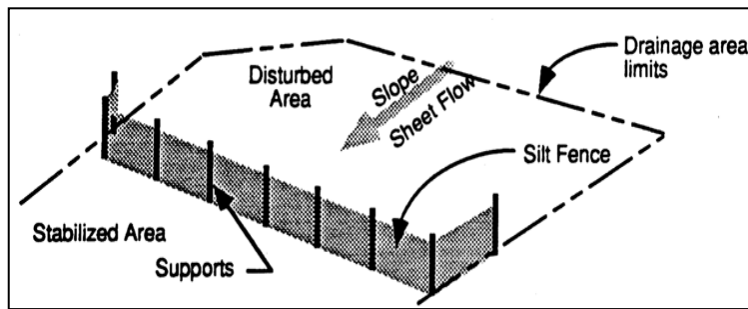

Description: A silt fence consists of geotextile fabric supported by wire mesh netting or other backing stretched between metal posts with the lower edge of the fabric securely embedded six-inches in the soil. The fence is typically located downstream of disturbed areas to intercept runoff in the form of sheet flow. A silt fence provides both filtration and time for sediment settling by reducing the velocity of the runoff.

KEY CONSIDERATIONS

DESIGN CRITERIA:

- Maximum drainage area of 0.25 acre per 100 linear feet of silt fence
- Maximum 200 feet distance of flow to silt fence; 50 feet if slope exceeds 10 percent
- Minimum fabric overlap of 3 feet at abutting ends; join fabric to prevent leakage
- Turn end of silt fence line upslope a minimum of 10 feet
- Install stone overflow structure at low points or spaced at approximately 300 feet if no apparent low point

ADVANTAGES / BENEFITS:

- Economical means to treat sheet flow
- Most effective with coarse to silty soil types

DISADVANTAGES / LIMITATIONS:

- Limited effectiveness with clay soils due to clogging
- Localized flooding due to minor ponding at the upslope side of the silt fence
- Not for use as check dams in swales or low areas subject to concentrated flow
- Not for use where soil conditions prevent a minimum toe-in depth of 6 inches or installation of support posts to a depth of 12 inches
- Can fail structurally under heavy storm flows, creating maintenance problems and reducing effectiveness

MAINTENANCE REQUIREMENTS:

- Inspect regularly
- Repair undercutting, sags and other fence failures
- Remove sediment before it reaches half the height of the fence
- Repair or replace damaged or clogged filter fabric

TARGETED POLLUTANTS

- Sediment
- Nutrients & Toxic Materials
- Oil & Grease
- Floatable Materials
- Other Construction Wastes

APPLICATIONS

Perimeter Control

Slope Protection

Sediment Barrier

Channel Protection

Temporary Stabilization

Final Stabilization

Waste Management

Housekeeping Practices

Fe=0.50-0.75

(Depends on soil type)

IMPLEMENTATION CONSIDERATIONS

- Capital Costs
- Maintenance
- Training
- Suitability for Slopes > 5%

Other Considerations:

- *Effects of ponding or the redirection of flow onto adjacent areas and property*

3.10.1 Primary Use

Silt fence is normally used as a perimeter control on the down slope side of disturbed areas and on side slopes where stormwater may runoff the area. It is only feasible for non-concentrated, sheet flow conditions. If it becomes necessary to place a silt fence where concentrated flows may occur (e.g. where two silt fences join at an angle, or across minor channels or gullies), it will be necessary to reinforce the silt fence at that area by a rock berm or sand bag berm, or other structural measures that will support the silt fence.

3.10.2 Applications

Silt fence is an economical means to treat overland, non-concentrated flows for all types of projects. Silt fences are used as perimeter control devices for both site developers and linear (roadway) type projects. They are most effective with coarse to silty soil types. Due to the potential of clogging and limited effectiveness, silt fences should be used with caution in areas that have predominantly clay soil types. In this latter instance, a soils engineer or soil scientist should confirm the suitability of silt fence for that application. Additional controls may be needed to remove fine silts and clay soils suspended in stormwater.

3.10.3 Design Criteria

- Fences are to be constructed along a line of constant elevation (along a contour line) where possible.
- Silt fence can interfere with construction operations; therefore, planning of access routes onto the site is critical.
- Maximum drainage area shall be 0.25 acre per 100 linear feet of silt fence.
- Maximum flow to any 20 foot section of silt fence shall be 1 CFS.
- Maximum distance of flow to silt fence shall be 200 feet or less. If the slope exceeds 10 percent the flow distance shall be less than 50 feet.
- Maximum slope adjacent to the fence shall be 2:1.
- Silt fences shall not be used where there is a concentration of water in a channel, drainage ditch or swale, nor should it be used as a control on a pipe outfall.
- If 50 percent or less soil, by weight, passes the U.S. Standard Sieve No. 200; select the apparent opening size (A.O.S.) to retain 85percent of the soil.
- If 85 percent or more of soil by weight, passes the U.S. Standard Sieve No. 200, silt fences shall not be used unless the soil mass is evaluated and deemed suitable by a soil scientist or geotechnical engineer concerning the erodibility of the soil mass, dispersive characteristics, and the potential grain-size characteristics of the material that is likely to be eroded.
- Stone overflow structures or other outlet control devices shall be installed at all low points along the fence or spaced at approximately 300 feet if there is no apparent low point.
- Filter stone for overflow structure shall be 1 ½ inches washed stone containing no fines. Angular shaped stone is preferable to rounded shapes.
- Silt fence fabric must meet the following minimum criteria:
 - Tensile Strength, ASTM D4632 Test Method for Grab Breaking Load and Elongation of Geotextiles, 90-lbs.
 - Puncture Rating, ASTM D4833 Test Method for Index Puncture Resistance of Geotextiles, Geomembranes, and Related Products, 60-lbs.
 - Mullen Burst Rating, ASTM D3786 Standard Test Method for Hydraulic Bursting Strength of Textile Fabrics-Diaphragm Bursting Strength Tester Method, 280-psi.

- Apparent Opening Size, ASTM D4751 Test Method for Determining Apparent Opening Size of a Geotextile, U.S. Sieve No. 30(max) to No. 100 (min).
- Ultraviolet Resistance, ASTM D4355 Standard Test Method for Deterioration of Geotextiles by Exposure to Light, Moisture, and Heat in a Xenon Arc Type Apparatus, Minimum 70 percent.
- Fence posts shall be steel and may be T-section or L-section, 1.3 pounds per linear foot minimum, and 4 feet in length minimum. Wood posts may be used depending on anticipated length of service and provided they are 4 feet in length minimum and have a nominal cross section of 2 inches by 4 inches for pine or 2 inches by 2 inches for hardwoods.
- Silt fence shall be supported by steel wire fence fabric as follows:
 - 4 inch x 4 inch mesh size, W1.4 /1.4, minimum 14 gauge wire fence fabric;
 - Hog wire, 12 gauge wire, small openings installed at bottom of silt fence;
 - Standard 2 inch x 2 inch chain link fence fabric; or
 - Other welded or woven steel fabrics consisting of equal or smaller spacing as that listed herein and appropriate gauge wire to provide support.
- Silt Fence shall consist of synthetic fabric supported by wire mesh and steel posts set a minimum of 1-foot depth and spaced not more than 6-feet on center.
- A 6 inch wide trench is to be cut 6 inches deep at the toe of the fence to allow the fabric to be laid below the surface and backfilled with compacted earth or gravel to prevent bypass of runoff under the fence. Fabric shall overlap at abutting ends a minimum of 3 feet and shall be joined such that no leakage or bypass occurs. If soil conditions prevent a minimum toe-in depth of 6 inches or installation of support post to depth of 12 inches, silt fences shall not be used.
- Sufficient room for the operation of sediment removal equipment shall be provided between the silt fence and other obstructions in order to properly maintain the fence.
- The last 10 feet (or more) at the ends of a line of silt fence shall be turned upslope to prevent bypass of stormwater. Additional upslope runs of silt fence may be needed every 200 to 400 linear feet, depending on the traverse slope along the line of silt fence.

3.10.4 Design Guidance and Specifications

Specifications for construction of this item may be found in the Standard Specifications for Public Works Construction – North Central Texas Council of Governments, Section 201.5 Silt Fence and in the Standard Specifications for Construction and Maintenance of Highways, Streets and Bridges (TxDot 2004) Item 506.2.J and Item 506.4.C.9.

The American Society for Testing and Materials has established standard specifications for silt fence materials (ASTM D6461) and silt fence installation (ASTM D6462).

3.10.5 Inspection and Maintenance Requirements

Silt fence should be inspected regularly (at least as often as required by the TPDES Construction General Permit) for buildup of excess sediment, undercutting, sags, and other failures. Sediment should be removed before it reaches half the height of the fence. In addition, determine the source of excess sediment and implement appropriate measures to control the erosion. Damaged or clogged fabric must be repaired or replaced as necessary.

3.10.6 *Example Schematics*

The following schematics are example applications of the construction control. They are intended to assist in understanding the control's design and function.

The schematics are **not for construction**. They may serve as a starting point for creating a construction detail, but they must be site adapted by the designer. In addition, dimensions and notes appropriate for the application must be added by the designer.

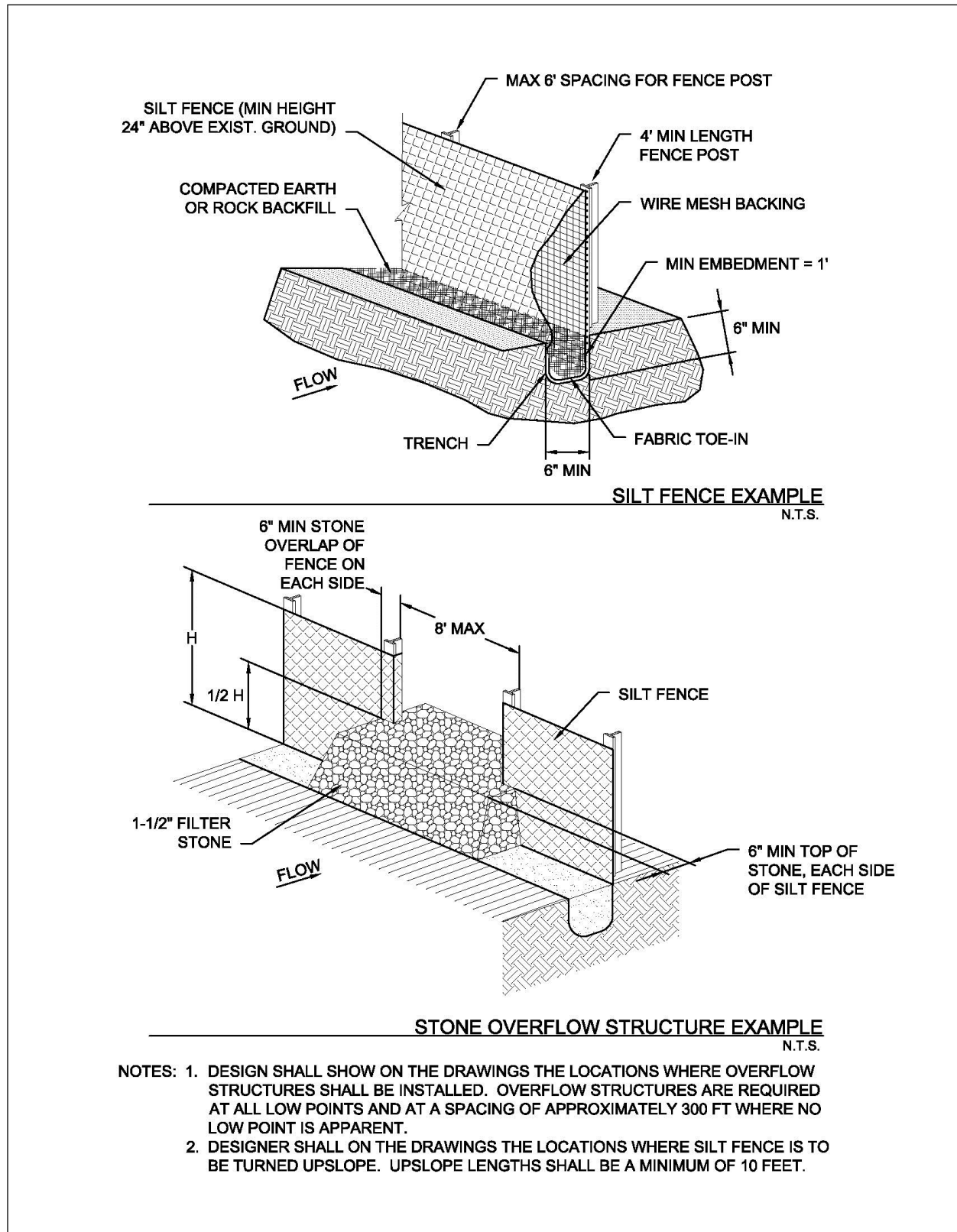
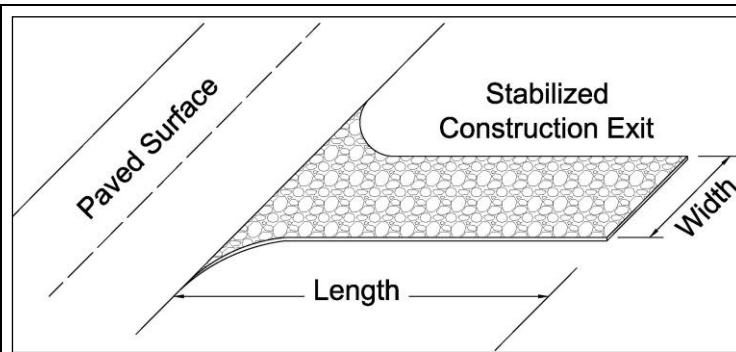

Figure 3.28 Schematics of Silt Fence

3.11 Stabilized Construction Exit

Sediment Control



Description: A stabilized construction exit is a pad of crushed stone, recycled concrete or other rock material placed on geotextile filter cloth to dislodge soil and other debris from construction equipment and vehicle tires prior to exiting the construction site. The object is to minimize the tracking of soil onto public roadways where it will be suspended by stormwater runoff.

KEY CONSIDERATIONS

DESIGN CRITERIA:

- Slope exit away from offsite paved surface
- Minimum width and length dependent on size of disturbed area, which correlates to traffic volume
- 6 inches minimum thickness of stone layer
- Stone of 3 to 5 inches in size
- Add a wheel cleaning system when inspections reveal the stabilized exit does not prevent tracking

ADVANTAGES / BENEFITS:

- Reduces tracking of soil onto public streets
- Directs traffic to a controlled access point
- Protects other sediment controls by limiting the area disturbed

DISADVANTAGES / LIMITATIONS:

- Effectiveness dependent on limiting ingress and egress to the stabilized exit
- A wheel washing system may also be required to remove clay soil from tires, particularly in wet conditions

MAINTENANCE REQUIREMENTS:

- Inspect regularly
- Replace rock when sediment in the void area between the rocks is visible on the surface
- Periodically re-grade and top dress with additional stone to maintain efficiency

APPLICATIONS

- Perimeter Control
- Slope Protection
- Sediment Barrier
- Channel Protection
- Temporary Stabilization**
- Final Stabilization
- Waste Management
- Housekeeping Practices

Fe=N/A

IMPLEMENTATION CONSIDERATIONS

- Capital Costs
- Maintenance
- Training
- Suitability for Slopes > 5%

Other Considerations:

- None

TARGETED POLLUTANTS

- Sediment
- Nutrients & Toxic Materials
- Oil & Grease
- Floatable Materials
- Other Construction Wastes

3.11.1 Primary Use

Stabilized construction exits are used to remove soil, mud and other matter from vehicles that drive off of a construction site onto public streets. Stabilized exits reduce the need to remove sediment from streets. When used properly, they also control traffic by directing vehicles a single (or two for larger sites) location. Controlling traffic onto and off of the site reduces the number and quantity of disturbed areas and provides protection for other sediment controls by decreasing the potential for vehicles to drive over the control.

3.11.2 Applications

Stabilized construction exits are used on all construction sites with a disturbed area of one acre or larger and are a recommended practice for smaller construction sites. A stabilized exit is used on individual residential lots until the driveway is placed. Stabilized construction exits may be used in conjunction with wheel cleaning systems as described in [Section 3.16 Wheel Cleaning Systems](#).

3.11.3 Design Criteria

- Limit site access to one route during construction, if possible; two routes for linear and larger projects.
- Prevent traffic from avoiding or shortcutting the full length of the construction exit by installing barriers. Barriers may consist of silt fence, construction safety fencing, or similar barriers.
- Design the access point(s) to be at the upslope side of the construction site. Do not place construction access at the lowest point on the construction site.
- Stabilized construction exits are to be constructed such that drainage across the exit is directed to a controlled, stabilized outlet onsite with provisions for storage, proper filtration, and removal of wash water.
- The exit must be sloped away from the paved surface so that stormwater from the site does not discharge through the exit onto roadways.
- Minimum width of exit shall be 15 feet.
- The construction exit material shall be a minimum thickness of 6 inches. The stone or recycled concrete used shall be 3 to 5 inches in size with little or no fines.
- The geotextile fabric must meet the following minimum criteria:
 - Tensile Strength, ASTM D4632 Test Method for Grab Breaking Load and Elongation of Geotextiles, 300 lbs.
 - Puncture Strength, ASTM D4833 Test Method for Index Puncture Resistance of Geotextiles, Geomembranes, and Related Products, 120 lbs.
 - Mullen Burst Rating, ASTM D3786 Standard Test Method for Hydraulic Bursting Strength of Textile Fabrics-Diaphragm Bursting Strength Tester Method, 600 psi.
 - Apparent Opening Size, ASTM D4751 Test Method for Determining Apparent Opening Size of a Geotextile, U.S. Sieve No. 40 (max).
- Rock by itself may not be sufficient to remove clay soils from wheels, particularly in wet conditions. When necessary, vehicles must be cleaned to remove sediment prior to entering paved roads, streets, or parking lots. Refer to [Section 3.16 Wheel Cleaning Systems](#) for additional controls.
- Using water to wash sediment from streets is prohibited
- Minimum dimensions for the stabilized exit shall be as follows:

<i>Disturbed Area</i>	<i>Min. Width of Exit</i>	<i>Min. Length of Exit</i>
< 1 Acre	15 feet	20 feet
≥ 1 Acre but < 5 Acres	25 feet	50 feet
≥ 5 Acres	30 feet	50 feet

- If a wheel cleaning system is used, the width of the stabilized exit may be reduced to funnel traffic into the system. Refer to [Section 3.16 Wheel Cleaning](#).

3.11.4 Design Guidance and Specifications

Specifications for construction of this item may be found in the Standard Specifications for Public Works Construction – North Central Texas Council of Governments, Section 201.10 Stabilized Construction Entrance and in the Standard Specifications for Construction and Maintenance of Highways, Streets and Bridges (TxDOT 2004) Item 506.2.E and Item 506.4.C.5.

3.11.5 Inspection and Maintenance Requirements

Construction exits should be inspected regularly (at least as often as required by the TPDES Construction General Permit). The stabilized construction exit shall be maintained in a condition that prevents tracking or flow of sediment onto paved surfaces. Periodic re-grading and top dressing with additional stone must be done to keep the efficiency of the exit from diminishing. The rock shall be re-graded when ruts appear. Additional rock shall be added when soil is showing through the rock surface.

Additional controls are needed if inspections reveal a properly installed and maintained exit, but tracking of soil outside the construction area is still evident. Additional controls may be daily sweeping of all soil spilled, dropped, or tracked onto public rights-of-way or the installation of a wheel cleaning system.

3.11.6 Example Schematics

The following schematics are example applications of the construction control. They are intended to assist in understanding the control's design and function.

The schematics are **not for construction**. They may serve as a starting point for creating a construction detail, but they must be site adapted by the designer. In addition, dimensions and notes appropriate for the application must be added by the designer.

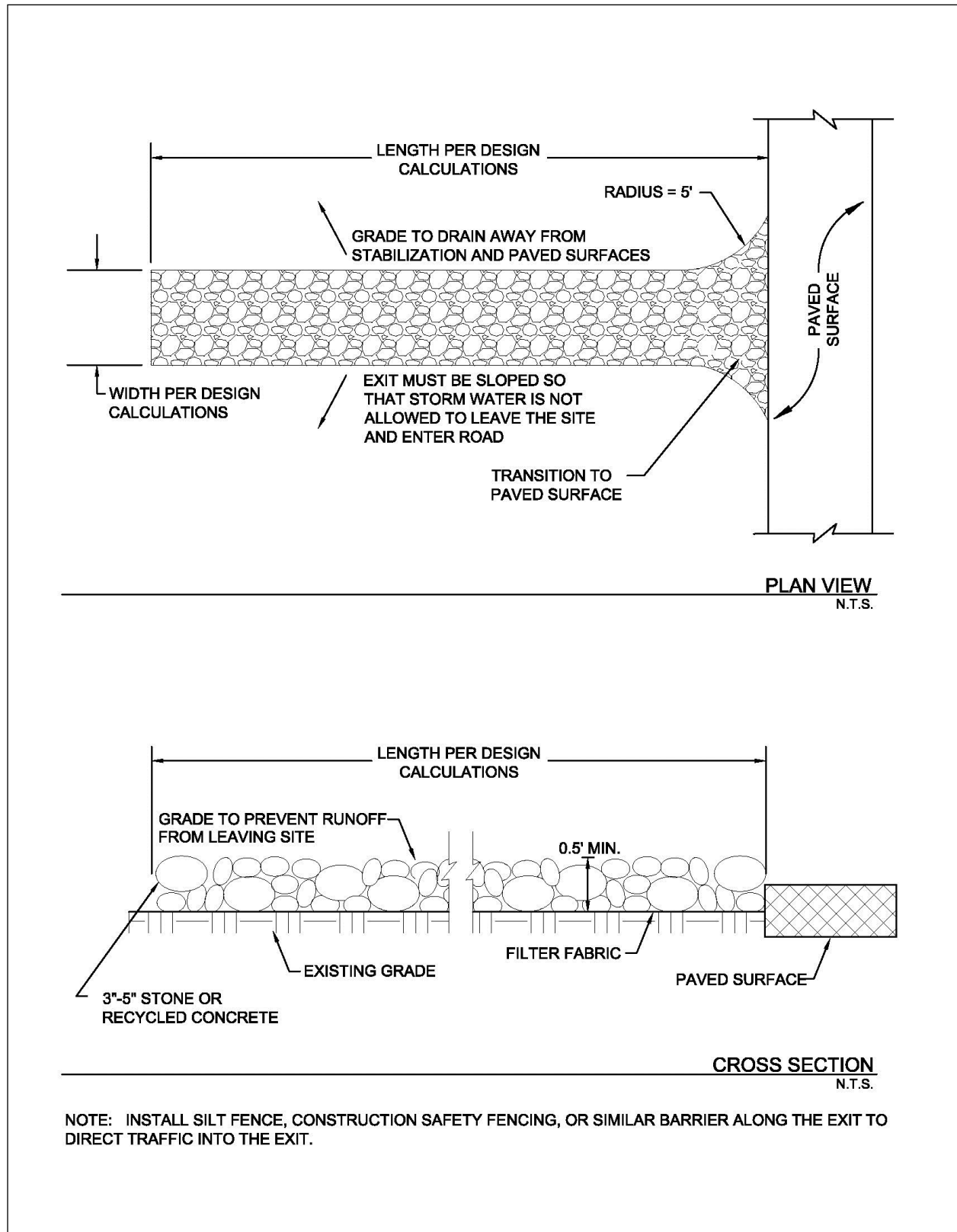
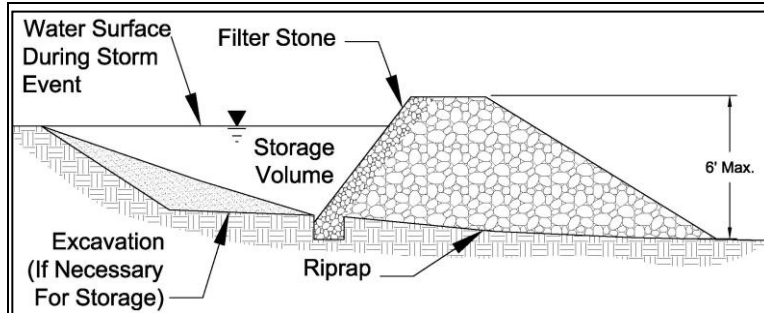

Figure 3.29 Schematics of Stabilized Construction Exit

3.12 Stone Outlet Sediment Trap

Sediment Control



Description: A stone outlet sediment trap is a small detention area formed by placing a stone embankment with an integral stone filter outlet across a drainage swale for the purpose of detaining sediment-laden runoff from construction activities. The sediment trap detains runoff long enough to allow most of the suspended sediment to settle while still allowing for diffused flow of runoff.

KEY CONSIDERATIONS

DESIGN CRITERIA:

- Maximum contributing drainage area of 10 acres for excavated trap and 5 acres for bermed trap
- Provide storage volume for the 2-year, 24-hour design storm
- Maximum embankment height of 6 feet
- Embankment slope of 1.5:1 or flatter
- 2 foot minimum top width

ADVANTAGES / BENEFITS:

- Effectively traps sediment in a drainage swale
- Reduces flow velocities
- Relatively long effective life

DISADVANTAGES / LIMITATIONS:

- Amount of land required
- Can cause minor upstream flooding, possibly impacting construction operations
- Not for use in "live" (normally flowing) channels

MAINTENANCE REQUIREMENTS:

- Inspect regularly
- Replace filter stone when it appears to be silted in such that efficiency is diminished
- Remove trash and debris after each storm event
- Remove deposited sediment when before the storage capacity is reduced by one third or has reached a depth of one foot, whichever is less

TARGETED POLLUTANTS

- Sediment
- Nutrients & Toxic Materials
- Oil & Grease
- Floatable Materials
- Other Construction Wastes

APPLICATIONS

- Perimeter Control
- Slope Protection
- Sediment Barrier**
- Channel Protection
- Temporary Stabilization
- Final Stabilization
- Waste Management
- Housekeeping Practices

Fe=0.50-0.85

(Depends on soil type)

IMPLEMENTATION CONSIDERATIONS

- Capital Costs
- Maintenance
- Training
- Suitability for Slopes > 5%

Other Considerations:

- *Re-grading and stabilization of the control area after construction*

3.12.1 Primary Use

A sediment trap is used where flows are concentrated in a drainage swale or channel. The sediment trap detains and temporarily impounds stormwater, which allows for settling of sediment as the water is slowly discharged from the trap. Sediment traps may be used in combination with check dams when erosive velocities exist in the swale upstream of the sediment trap.

3.12.2 Applications

Temporary stone outlet sediment traps are installed at locations where concentrated flows require a protected outlet to contain sediment or spread flow prior to discharge. They are an effective, long term (12 – 18 months) application for sediment control on large construction sites where a sediment basin is not feasible due to site or construction method restrictions. Several traps may be used to control sediment on drainage sub-basins within the construction site, instead of one large sediment basin at the discharge point from the entire construction site. Sediment traps may also be used with a passive treatment system to provide better removal of fine silt and clay soil particles.

3.12.3 Design Criteria

- Design calculations are required for the use of this control. The designer shall provide drainage computations and dimensions for the stone outlet, berms, and excavated areas associated with this control.
- The maximum drainage area contributing to the trap shall be less than 10 acres for the excavated stone outlet sediment trap and 5 acres or less for the bermed trap.
- The minimum storage volume shall be the volume of runoff from the temporary control design storm (2-year, 24 hour) for the sediment trap's drainage area.
- The surface area of the design storage area shall not be less than 1 percent of the area draining to the device.
- The maximum height of the rock shall be 6 feet, as measured from the toe of the slope on the downstream side to the low point in the rock dam.
- Minimum width of the rock dam at the top shall be 2 feet.
- Rock dam slope shall be 1.5:1 or flatter.
- The rock dam shall have a depressed area, over the center of swale, to serve as the outlet with a minimum width of 4 feet.
- A six inch minimum thickness layer of 1½ inch filter stone shall be placed on the upstream face of the stone embankment when the stormwater runoff contains fine silt and clay soil particles.
- The embankment shall be comprised of well graded stone with a size range of 6 to 12 inches in diameter. The stone may be enclosed in wire mesh or gabion basket and anchored to the channel bottom to prevent washing away.
- The dam shall consist of stone riprap or a combination of compacted fill with a stone riprap outlet.
- Fill placed to constrict the swale for construction of the excavated stone outlet sediment trap and fill placed for the berm in the bermed stone outlet sediment trap shall consist of clay material, minimum Plasticity Index of 30, using ASTM D4318 Standard Test for Liquid Limit, Plastic Limit, and Plasticity Index of Soils.
- Fill shall be placed in 8 inch loose lifts (maximum) and compacted to 95% Standard Proctor Density at optimum moisture content using ASTM D698 Standard Test Methods for Laboratory Compaction Characteristics of Soil Using Standard Effort.
- The outlet shall be designed to have a minimum freeboard of 6" at design flow.

- Rock shall be placed on geotextile filter fabric meeting the following minimum criteria:
 - Tensile Strength, ASTM D4632 Test Method for Grab Breaking Load and Elongation of Geotextiles, 250-lbs.
 - Puncture Rating, ASTM D4833 Test Method for Index Puncture Resistance of Geotextiles, Geomembranes, and Related Products, 135-lbs.
 - Mullen Burst Rating, ASTM D3786 Standard Test Method for Hydraulic Bursting Strength of Textile Fabrics-Diaphragm Bursting Strength Tester Method, 420-psi.
 - Apparent Opening Size, ASTM D4751 Test Method for Determining Apparent Opening Size of a Geotextile, U.S. Sieve No. 20 (max).
- The geotextile fabric, covered with a layer of stone, shall extend past the base of the embankment on the downstream side a minimum of 2 feet.

3.12.4 Design Guidance and Specifications

Specifications for construction of this item may be found in the Standard Specifications for Public Works Construction – North Central Texas Council of Governments, Section 201.12 Stone Outlet Sediment Trap.

3.12.5 Inspection and Maintenance Requirements

The stone outlet sediment trap should be inspected regularly (at least as often as required by the TPDES Construction General Permit) to check for clogging of the void spaces between stones. If the filter stone appears to be clogged, such that the basin will not completely drain, then the filter stone will require maintenance. If the filter stone is not completely clogged it may be raked with a garden rake to allow the water to release from the basin. If filter stone is completely clogged with mud and sediment, then the filter stone will have to be removed and replaced. Failure to keep the filter stone material properly maintained will lead to clogging of the stone riprap embankment. When this occurs, the entire stone rip-rap structure will need to be replaced. If the aggregate appears to be silted in such that efficiency is diminished, the stone should be replaced.

Trash and debris should be removed from the trap after each storm event to prevent it from plugging the rock. Deposited sediment shall be removed before the storage capacity is decreased by one-third, or sediment has reached a depth of one foot, whichever is less. The removed sediment shall be stockpiled or redistributed in areas that are protected with erosion and sediment controls.

3.12.6 Example Schematics

The following schematics are example applications of the construction control. They are intended to assist in understanding the control's design and function.

The schematics are **not for construction**. They may serve as a starting point for creating a construction detail, but they must be site adapted by the designer. In addition, dimensions and notes appropriate for the application must be added by the designer.

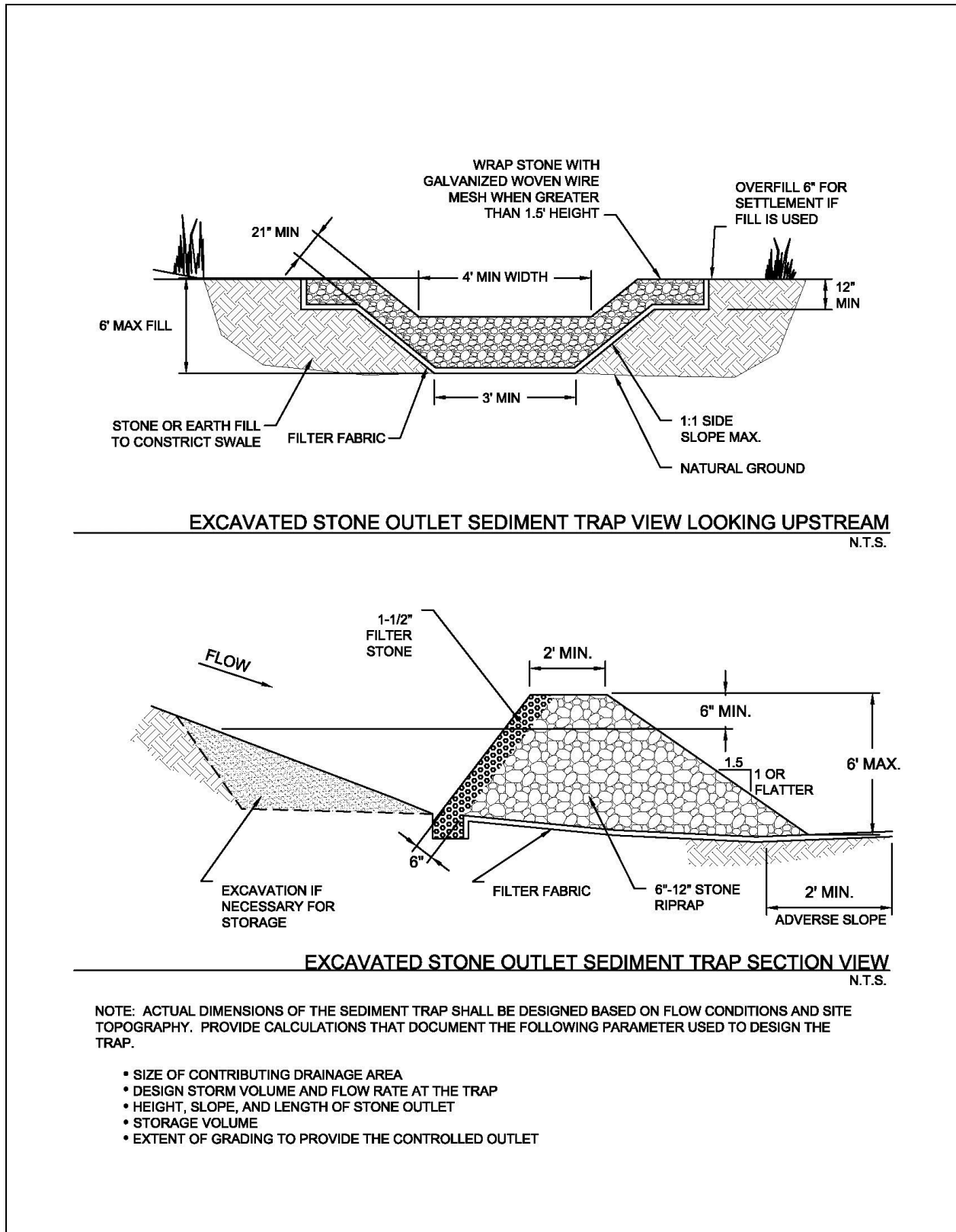

Figure 3.30 Schematics of Excavated Stone Outlet Sediment Trap

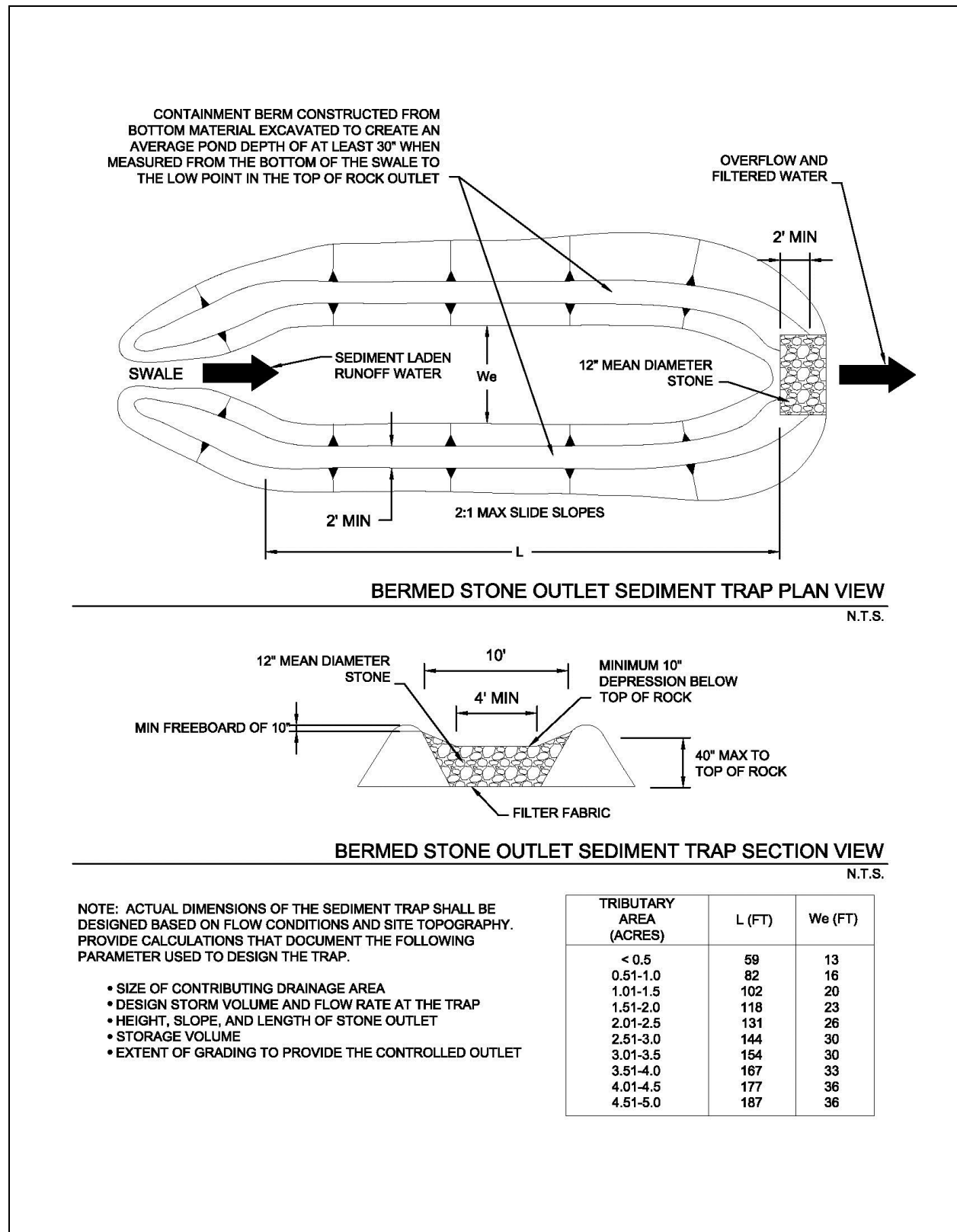
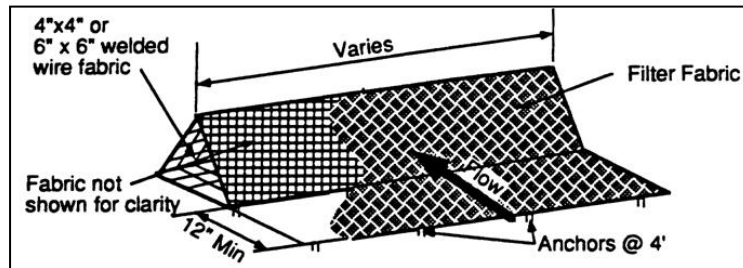

Figure 3.31 Schematics of Bermed Stone Outlet Sediment Trap
(Source: City of Chesterfield Department of Public Works Detail SC 7.2)

3.13 Triangular Sediment Filter Dike

Sediment Control



Description: A triangular sediment filter dike is a self-contained silt fence consisting of filter fabric wrapped around welded wire fabric and shaped into a triangular cross section. While similar in use to a silt fence, the dike is reusable, sturdier, transportable, and can be used on paved areas or in situations where it is impractical to install embedded posts for support.

KEY CONSIDERATIONS

DESIGN CRITERIA:

- Maximum drainage area of 0.25 acre per 100 linear feet of dike
- Maximum 200 feet distance of flow to filter dike; 50 feet if slope exceeds 10 percent
- Overlap ends of filter material 6 inches to cover dike-to-dike junction; secure with shoat rings

ADVANTAGES / BENEFITS:

- Can be installed on paved surfaces or where the soil type prevents embedment of other controls
- Withstands more concentrated flow and higher flow rates than silt fence

DISADVANTAGES / LIMITATIONS:

- Localized flooding due to minor ponding at the upslope side of the filter dike
- Not effective where there are substantial concentrated flows
- Not effective along contours due to the potential for flow concentration and overtopping

MAINTENANCE REQUIREMENTS:

- Inspect regularly
- Remove sediment before it reaches 6 inches in depth
- Clean or replace fabric if clogged
- Repair or replace dike when structural deficiencies are found

TARGETED POLLUTANTS

- Sediment
- Nutrients & Toxic Materials
- Oil & Grease
- Floatable Materials
- Other Construction Wastes

APPLICATIONS

Perimeter Control

Slope Protection

Sediment Barrier

Channel Protection

Temporary Stabilization

Final Stabilization

Waste Management

Housekeeping Practices

Fe=0.50-0.75

(Depends on soil type)

IMPLEMENTATION CONSIDERATIONS

- Capital Costs
- Maintenance
- Training
- Suitability for Slopes > 5%

Other Considerations:

- *Effects of ponding on adjacent areas and property*

3.13.1 Primary Use

Triangular filter dikes are used in place of silt fence, treating sediment flow at the perimeter of construction areas and at the perimeter of the site. Also, the dikes can serve as stream protection devices by preventing sediment from entering the streams or as check dams in small swales.

Triangular sediment filter dikes are especially useful for construction areas surrounded by pavement, where silt fence, filter berm, or other sediment control installations are impractical.

3.13.2 Applications

Triangular dikes are used to provide perimeter control by detaining sediment on a disturbed site with drainage that would otherwise flow onto adjacent properties. Triangular dikes function as sediment trapping devices when used in areas of sheet flow across disturbed areas or are placed along stream banks to prevent sediment-laden sheet flow from entering the stream. The dikes can be subjected to more concentrated flows and a higher flow rate than silt fence.

Dikes can be used on a variety of surfaces where other controls are not effective. They may be installed on paved surfaces and where the soil type prevents embedment of other sediment controls.

3.13.3 Design Criteria

- Dikes are to be installed along a line of constant elevation (along a contour line).
- Maximum drainage area shall be 0.25 acre per 100 linear feet of dike.
- Maximum flow to any 20 foot section of dike shall be 1 CFS.
- Maximum distance of flow to dike shall be 200 feet or less. If the slope exceeds 10 percent, the flow distance shall be less than 50 feet.
- Maximum slope adjacent to the dike shall be 2:1.
- If 50 percent or less of soil, by weight, passes the U.S. Standard Sieve No. 200, select the apparent opening size (A.O.S.) to retain 85 percent of the soil.
- If 85 percent or more of soil, by weight, passes the U.S. Standard Sieve No. 200, triangular sediment dike shall not be used due to clogging.
- The filter fabric shall meet the following minimum criteria:
 - Tensile Strength, ASTM D4632 Test Method for Grab Breaking Load and Elongation of Geotextiles 90-lbs.
 - Puncture Rating, ASTM D4833 Test Method for Index Puncture Resistance of Geotextiles, Geomembranes, and Related Products, 60-lbs.
 - Mullen Burst Rating, ASTM D3786 Standard Test Method for Hydraulic Bursting Strength of Textile Fabrics-Diaphragm Bursting Strength Tester Method, 280-psi.
 - Apparent Opening Size, ASTM D4751 Test Method for Determining Apparent Opening Size of a Geotextile, U.S. Siev No. 30 (max) to 100 (min).
 - Ultraviolet Resistance, ASTM D4355 Standard Test Method for Deterioration of Geotextiles by Exposure to Light, Moisture, and Heat in a Xenon Arc Type Apparatus, Minimum 70 percent.
- The internal support for the dike structure shall be 6-gauge 6 inch x 6 inch wire mesh or 6-gauge 4 inch x 4 inch welded wire fabric folded into triangular form eighteen (18) inches on each side.
- Tie-in to the existing grade should be accomplished by:
 - (i) embedding the fabric six-inches below the top of ground on the upslope side;

- (ii) extending the fabric to form a 12 inch skirt on the upstream slope and covering it with 3 to 5 inches of 1½ inch washed filter stone; or
- (iii) entrenching the base of the triangular dike four inches below ground.

For (ii) above, the skirt and the upslope portion of the triangular dike skeleton should be anchored by metal staples on two-foot centers, driven a minimum of six inches into the ground (except where crossing pavement or exposed limestone). When installed on pavement, the washed rock in option (ii) may be replaced by bags filled with 1½ inch washed filter stone placed at 4 foot spacing to anchor the end of the filter fabric to the pavement.

- Filter material shall lap over ends six (6) inches to cover dike-to-dike junction; each junction shall be secured by shoat rings. Where the dike is placed on pavement, two rock bags shall be used to anchor the overlap to the pavement. Additional bags shall be used as needed to ensure continuous contact with the pavement (no gaps).
- Sand bags or large rock should be used as ballast inside the triangular dike section to stabilize the dike against the effects of high flows.
- Sufficient room for the operation of sediment removal equipment shall be provided between the dike and other obstructions in order to properly remove sediment.
- The ends of the dike shall be turned upgrade to prevent bypass of stormwater.
- When used as a perimeter control on drainage areas larger than 0.5 acres, a stone overflow structure, similar to the one shown in [Section 3.10 Silt Fence](#), may be necessary at low points to act as a controlled overflow point in order to prevent localized flooding and failure of the dike.
- If used as check dams in small swales (drainage areas less than 3 acres), the dikes shall be installed according to the spacing and other criteria in [Section 2.1 Check Dam](#).

3.13.4 Design Guidance and Specifications

Specifications for construction of this item may be found in the Standard Specifications for Public Works Construction – North Central Texas Council of Governments, Section 201.8 Triangular Sediment Filter Dike.

3.13.5 Inspection and Maintenance Requirements

Triangular sediment filter dikes should be inspected regularly (at least as often as required by the TPDES Construction General Permit). Sediment should be removed before it reaches 6 inches in depth. If the fabric becomes clogged, it should be cleaned or, if necessary, replaced. If structural deficiencies are found, the dike should be immediately repaired or replaced.

The integrity of the filter fabric is important to the effectiveness of the dike. Overlap between dike sections must be checked on a regular basis and repaired if deficient.

3.13.6 Example Schematics

The following schematics are example applications of the construction control. They are intended to assist in understanding the control's design and function.

The schematics are **not for construction**. They may serve as a starting point for creating a construction detail, but they must be site adapted by the designer. In addition, dimensions and notes appropriate for the application must be added by the designer.

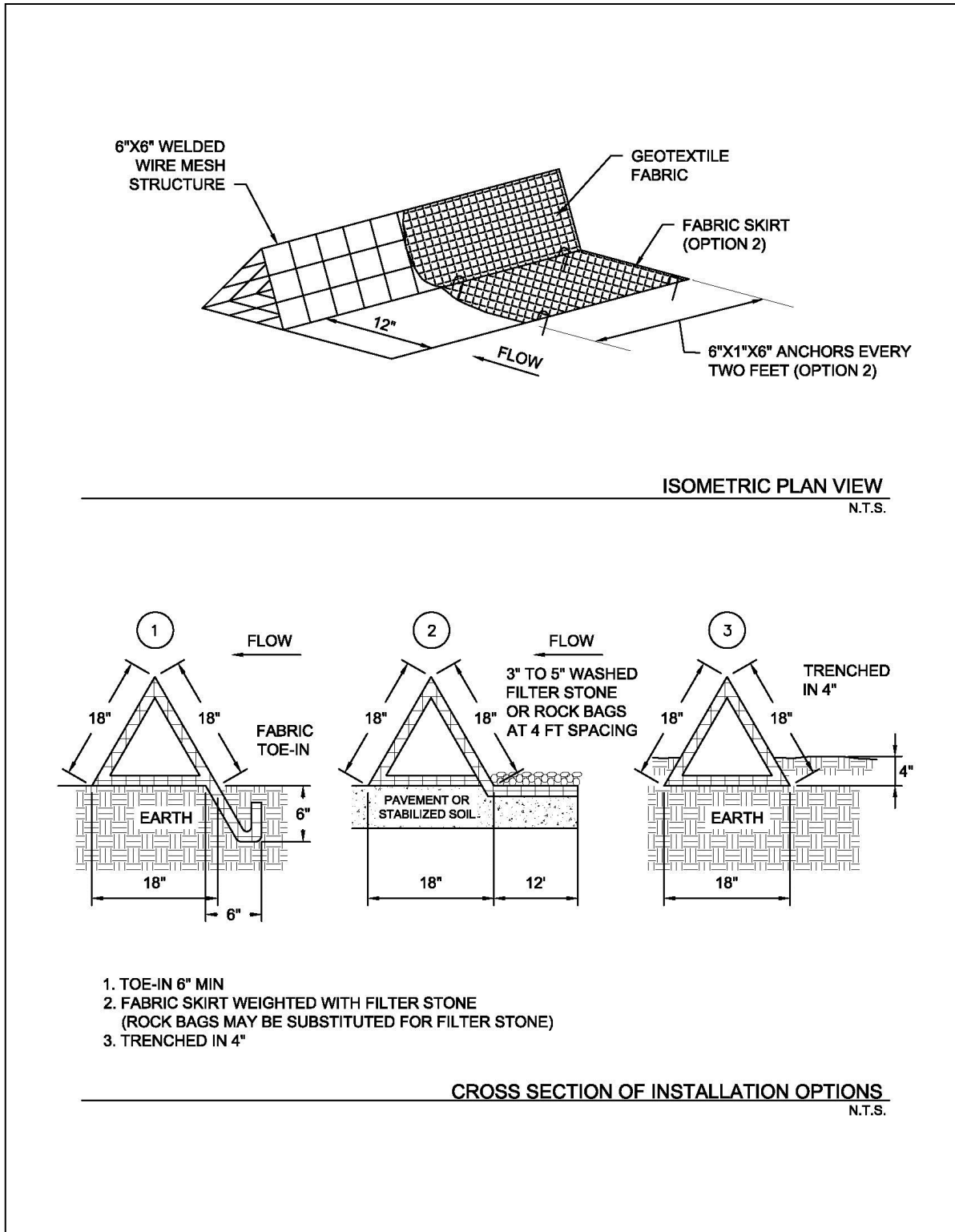
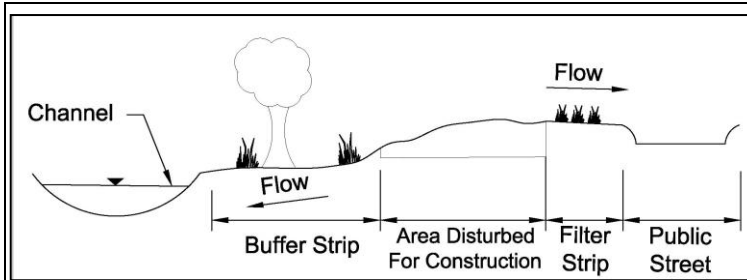

Figure 3.32 Schematics of Triangular Sediment Filter Dike

3.15 Vegetated Filter Strips and Buffers

Sediment Control



Description: Buffer strips (existing vegetation) and filter strips (planted vegetation) are sections of vegetated land adjacent to disturbed areas. They are designed with low slopes to convey sheet flow runoff from disturbed areas, resulting in the removal of sediment and other pollutants as the runoff passes through vegetation and infiltration occurs.

KEY CONSIDERATIONS

DESIGN CRITERIA:

- Minimum width (direction of flow across the vegetation) dependent on slope of disturbed area
- Maximum ratio of disturbed area to vegetated area dependent on slope
- Existing vegetation must meet criteria for type and coverage
- Dense grass required for planted vegetation
- Demarcate limits of vegetation and protect from traffic

ADVANTAGES / BENEFITS:

- Effective secondary control for removing clay particles
- Disperses flow and slows velocities to decrease erosion potential in receiving water
- Preserves the character of existing riparian corridor
- May become part of the permanent stormwater controls

DISADVANTAGES / LIMITATIONS:

- Appropriate as a primary control only for drainage areas of 2 acres or less and under certain site conditions
- Maximum 150 feet of flow to vegetated strip or buffer is used as a primary control
- Cannot treat large volumes or concentrated flows
- Not effective as a perimeter control when the perimeter cuts across contours instead of following contours
- Must limit access to vegetated portion of the site

MAINTENANCE REQUIREMENTS:

- Inspect regularly
- Rake accumulations of sediment from the vegetation
- Repair bare areas

TARGETED POLLUTANTS

- Sediment
- Nutrients & Toxic Materials
- Oil & Grease
- Floatable Materials
- Other Construction Wastes

APPLICATIONS

Perimeter Control
Slope Protection
Sediment Barrier

- Channel Protection
- Temporary Stabilization
- Final Stabilization
- Waste Management
- Housekeeping Practices

Fe=0.35-0.85

(Depends on many conditions in addition to soil type)

IMPLEMENTATION CONSIDERATIONS

- Capital Costs
- Maintenance
- Training
- Suitability for Slopes > 5%

Other Considerations:

- *Coordination with final landscaping*

3.15.1 Primary Use

Vegetated filter strips and buffers are used to reduce the velocity of sheet flow and reduce the volume of runoff through infiltration. In the process, sediment is removed as the runoff is filtered through the vegetation and infiltration occurs.

Vegetated filter strips and buffers are frequently used as a secondary sediment control, since their performance is highly variable. They may be used as a primary sediment control only for small areas and under select site conditions.

3.15.2 Applications

Vegetated buffers are most applicable on development projects that are adjacent or near to floodplains, wetlands, streams and other natural waterways. Vegetated strips may be established along roads and property lines as a perimeter control for development. They are also applicable along the down slope side of utility line projects.

Vegetated buffers may be a primary sediment control for small areas where the conditions meet design criteria. They are also commonly used as a secondary control with other perimeter controls to provide higher levels of sediment removal. Vegetated areas have more capability to remove fine particle sizes than many conventional sediment controls. Combinations such as an organic filter tube or silt fence at the upslope edge of a vegetated strip are very effective.

In addition to perimeter control, vegetated strips are applicable for slope protection. Strips may be established at regular intervals to interrupt long or steep slopes. The strips maintain sheet flow, decrease velocities, and decrease erosion on the slopes.

3.15.3 Design Criteria

Vegetated buffers should be preserved along existing floodplains, wetlands, channels, and other natural waters whenever possible, even when the buffer is not a primary sediment control. Check for local requirements, as many municipalities mandate a vegetated buffer to maintain the character of the riparian corridor along a natural waterway. Vegetated buffers are encouraged to protect existing waterways by decreasing velocities, dispersing flow, and attenuating volume before the runoff reaches the waterway. If the development plans necessitate disturbing the riparian corridor, phase the development (when possible) to retain a vegetated buffer until final grading and landscaping at the end construction.

The evaluation and use of vegetated strips and buffers for use as a sediment control are unique to each site. The designer should carefully consider slope, vegetation, soils, depth to impermeable layer, depth to ground water, and runoff sediment characteristics before specifying a vegetated strip or buffer as a primary sediment control. This consideration is especially true for buffer strips of existing vegetation. If the buffer is not correctly planned, the first storm event can damage the natural vegetation beyond repair.

Design criteria in this section are only applicable when a vegetated strip or buffer is intended to be a primary or secondary sediment control for the construction site. As discussed above, a vegetated buffer may be preserved for other reasons that do not necessitate the use of these criteria if other sediment controls are provided for the construction site.

General

- Maximum slope of the vegetated strip or buffer shall be 5% across the width of the vegetation in the direction of flow.
- To maintain sheet flow, maximum distance of flow to the vegetated filter shall be 150 feet.
- Vegetated buffers and strips may only serve as a primary sediment control when the contributing drainage area has a slope of 15% or less. On steeper slopes, another perimeter control (e.g. organic filter tube, silt fence) may be installed at the upslope edge of the vegetated buffer or strip as a primary control, with the vegetation serving as a secondary control.

- Maximum disturbed area contributing runoff to the vegetated strip or buffer shall be 2 acres.
- Vegetated filter strips and buffers shall be a minimum of 15 feet wide. Width shall be increased based on the slope of the disturbed area as shown in the following table. Although the slope of the disturbed area may be up to 15%, the slope of the vegetated strip or buffer is still limited to 5% maximum if used as a primary control for sediment.

Maximum Slope of Contributing Drainage Area	Maximum Ratio of Disturbed Area to Vegetated Area	Minimum Width of Vegetated Area (Direction of Flow)
5%	8:1	15 feet
10%	5:1	30 feet
15%	3:1	50 feet

- Access to vegetated buffers and strips shall be prohibited. These areas shall be protected from all traffic. No activities should occur in these areas, including no parking of the workers' vehicles, no eating of lunch, etc.
- Install controlled and stabilized ingress/egress points to manage traffic and direct it away from vegetation. Fence the vegetation or provide other means of protection to prevent vehicles and equipment from driving on the vegetated areas.
- Vegetated buffers and filter strips should not be used when high ground water, shallow depth to bedrock, or low soil permeability will inhibit infiltration of runoff.

Buffers of Existing Vegetation

- Fencing, flagged stakes spaced at a maximum of 6 feet, or other measures shall be used to clearly mark existing vegetation that is being preserved as a buffer before the start of any clearing, grubbing, or grading.
- Existing vegetation must be well established to be used as a vegetated buffer. It may be a mix of trees, sapling/shrubs, vines and herbaceous plants. However, the herbaceous plants shall cover at least 80 percent of the ground area.
- Bare soil shall not be visible within the buffer. Area between herbaceous plants shall be covered with a natural litter of organic matter (e.g. leaves, dead grass).
- Lots with a thick stand of existing grasses may preserve strips of the grasses as perimeter control in addition to using vegetation as a buffer along a natural waterway.

Strips of Planted Vegetation

- Vegetated strips should only be used when the site perimeter is along (parallel to) contours. Erosion of the vegetated strip will be a problem when the strip is placed along roads or site perimeters that cut across contours, resulting in runoff flowing along, instead of across, the filter strip.
- Minimize vehicle and equipment traffic and other activities that could compact soils on areas that will be planted for vegetated strips.
- Sod is required when the strip is intended to immediately function as a sediment control.
- Erosion control blankets (ECBs) should be used to prevent erosion and provide sediment control while establishing vegetation for a filter strip. If ECBs are not used, then another perimeter control is required until the vegetation is mature. Refer to [Section 2.3 Erosion Control Blankets](#).
- Refer to the [Section 2.9 Vegetation](#) for criteria on establishing vegetation.
- When using vegetated strips for slope protection, spacing of the strips should be designed based on

slope steepness and type of soil. The strips may be planted directly on the slope grade when the slope is flatter than 2:1. For slopes of 2:1 and steeper, vegetation should be established on terraces. Terraces shall have a transverse slope of 1 percent in the opposite direction of the slope (i.e. back into the ground).

3.15.4 *Design Guidance and Specifications*

Guidance for analysis of the hydraulic loading on filter strips is in *Section 13.3 of the Stormwater Controls Technical Manual*.

No specification for vegetated filter strips and buffers is currently available in the Standard Specifications for Public Works Construction – North Central Texas Council of Governments.

3.15.5 *Inspection and Maintenance Requirements*

Vegetated filter strips and buffers should be inspected regularly (at least as often as required by the TPDES Construction General Permit). If rill erosion is developing, additional controls are needed to spread the flow before it enters the vegetated area. Rake light accumulations of sediment from the vegetation. Remove trash that accumulates in the vegetation. Additional sediment controls (e.g. a line of organic filter tubes or silt fence), are needed if sediment accumulations are large enough to bury the vegetation.

Inspect established planted vegetation for bare areas and place sod or install seeded erosion control blankets, as appropriate. Mow as needed after planted vegetation is mature.

3.15.6 *Example Schematics*

The following schematics are example applications of the construction control. They are intended to assist in understanding the control's design and function.

The schematics are **not for construction**. They may serve as a starting point for creating a construction detail, but they must be site adapted by the designer. In addition, dimensions and notes appropriate for the application must be added by the designer.

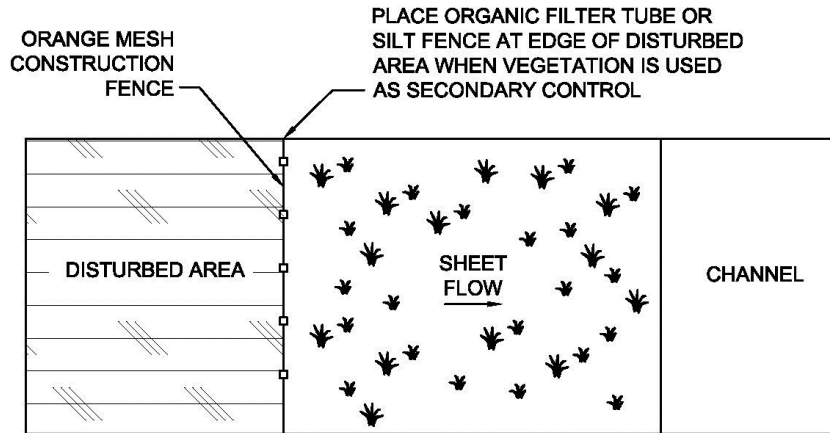

VEGETATED FILTER STRIP PLAN VIEW
N.T.S.

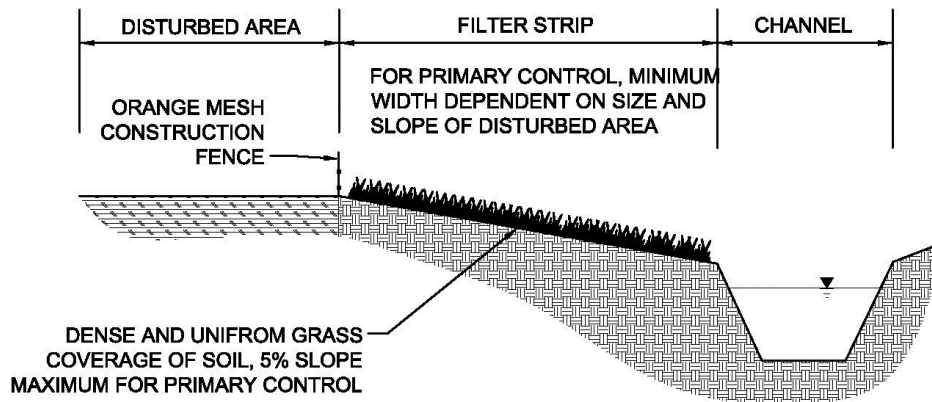

VEGETATED FILTER STRIP PROFILE VIEW
N.T.S.

Figure 3.35 Schematics of Vegetated Filter Strip

4.3 Concrete Waste Management

Waste Control

Description: Concrete waste at construction sites comes in two forms: 1) excess fresh concrete mix, including residual mix washed from trucks and equipment, and 2) concrete dust and concrete debris resulting from demolition. Both forms have the potential to impact water quality through stormwater runoff contact with the waste. The objective of concrete waste management is to dispose of these wastes in a manner that protects surface and ground water.

<p style="text-align: center;"><u>KEY CONSIDERATIONS</u></p> <p>DESIGN CRITERIA:</p> <ul style="list-style-type: none"> ● Prohibit the discharge of untreated concrete washout water ● Prohibit dumping waste concrete anywhere except at pre-determined, regulated, recycling or disposal sites ● Provide a washout containment with a minimum of 6 cubic feet of containment volume for every 10 cubic yards of concrete placed ● Minimum 1 foot freeboard on containment ● Minimum 10 mil plastic lining of containment ● Washout water evaporation and concrete recycling are the recommended disposal methods ● Educate drivers and operators on proper disposal and equipment cleaning procedures <p>LIMITATIONS:</p> <ul style="list-style-type: none"> ● Does not address concrete sawcutting waste <p>MAINTENANCE REQUIREMENTS:</p> <ul style="list-style-type: none"> ● Inspect regularly ● Check for and repair any damage to washout containment areas ● Clean up any overflow of washout pits ● Regularly remove and properly dispose of concrete waste 	<p style="text-align: center;"><u>APPLICATIONS</u></p> <p>Perimeter Control</p> <p>Slope Protection</p> <p>Sediment Barrier</p> <p>Channel Protection</p> <p>Temporary Stabilization</p> <p>Final Stabilization</p> <div style="border: 1px solid black; padding: 2px; text-align: center; margin: 5px 0;"> <p>Waste Management</p> </div> <p>Housekeeping Practices</p> <hr/> <p><u>IMPLEMENTATION CONSIDERATIONS</u></p> <ul style="list-style-type: none"> ○ Capital Costs ○ Maintenance ● Training ○ Suitability for Slopes > 5% <p>Other Considerations:</p> <ul style="list-style-type: none"> ● <i>None</i>
<p style="text-align: center;"><u>TARGETED POLLUTANTS</u></p> <ul style="list-style-type: none"> ○ Sediment ● Nutrients & Toxic Materials ○ Oil & Grease ○ Floatable Materials ● Other Construction Wastes 	

4.3.1 Primary Use

Concrete waste management is used to prevent the discharge of concrete wash water and waste into stormwater runoff. A number of water quality parameters can be affected by the introduction of concrete, especially fresh concrete. Concrete affects the pH of runoff, causing significant chemical changes in water bodies and harming aquatic life. Suspended solids in the form of both cement and aggregated dust are also generated from both fresh and demolished concrete waste.

4.3.2 Applications

Concrete waste management is applicable to all construction sites where existing concrete is being demolished or new concrete is being placed, regardless of the size of the total area disturbed. It is also applicable on repair and maintenance projects that may not be required to implement erosion and sediment controls.

4.3.3 Design Criteria

- The discharge of washout water to an inlet, swale, or any portion of the storm drainage system or a natural drainage system (e.g. channel) shall be prohibited.
- Construction plan notes shall state that the discharge of concrete washout to anything except a designated containment area is prohibited.
- Show the location of the concrete washout containment on the drawings, or require the contractor to provide this information.
- The contractor should be required to designate the site superintendent, foreman, or other person who is responsible for concrete placement to also be responsible for concrete waste management.

Unacceptable Waste Concrete Disposal Practices

- Dumping in vacant areas on the job-site.
- Illicit dumping onto off-site lots or any other placed not permitted to receive construction demolition debris.
- Dumping into ditches, drainage facilities, or natural water ways.
- Using concrete waste as fill material or bank stabilization.

Recommended Disposal Procedures

- Identify pre-determined, regulated, facilities for disposal of solid concrete waste. Whenever possible, haul the concrete waste to a recycling facility. Disposal facilities must have a Class IV (or more stringent) municipal solid waste permit from the TCEQ.
- A concrete washout pit or other containment shall be installed a minimum of 50 feet away from inlets, swales, drainage ways, channels, and other waters, if the site configuration provides sufficient space to do so. In no case shall concrete washout occur closer than 20 feet from inlets, swales, drainage ways, channels and other waters.
- Provide a washout area with a minimum of 6 cubic feet of containment volume for every 10 cubic yards of concrete poured. Alternatively, the designer may provide calculations sizing the containment based on the number of concrete trucks and pumps to be washed out.
- The containment shall be lined with plastic (minimum 10 millimeters thick) or an equivalent measure to prevent seepage to groundwater.
- Mosquitoes do not typically breed in the high pH of concrete washout water. However, the concrete washout containment should be managed in a manner that prevents the collection of other water that could be a potential breeding habitat.

- Do not excavate the washout area until the day before the start of concrete placement to minimize the potential for collecting stormwater.
- Do not discharge any water or wastewater into the containment except for concrete washout to prevent dilution of the high pH environment that is hostile to mosquitoes.
- Remove the waste concrete and grade the containment closed within a week of completing concrete placement. Do not leave it open to collect stormwater.
- If water must be pumped from the containment, it shall be collected in a tank, neutralized to lower the pH, and then hauled to a treatment facility for disposal. Alternatively, it may be hauled to a batch plant that has an onsite collection facility for concrete washout water.
- Do **not** pump water directly from the containment to the Municipal Separate Storm Sewer System or a natural drainage way without treating for removal of fine particles and neutralization of the pH.
- Multiple concrete washout areas may be needed for larger projects to allow for drying time and proper disposal of the washout water and waste concrete.
- Portable, pre-fabricated, concrete washout containers are commercially available and are an acceptable alternative to excavating a washout area.
- Evaporation of the washout water and recycling of the concrete waste is the preferred disposal method. After the water has evaporated from the washout containment, the remaining cuttings and fine sediment shall be hauled from the site to a concrete recycling facility or a solid waste disposal facility.
- Remove waste concrete when the washout containment is half full. Always maintain a minimum of one foot freeboard.
- Use waste and recycling haulers and facilities approved by the local municipality.
- When evaporation of the washout water is not feasible, discharge from the collection area shall only be allowed if a passive treatment system is used to remove the fines. Criteria are in [Section 3.7 Passive Treatment System](#). Mechanical mixing is required within the containment for passive treatment to be effective. The pH must be tested, and discharge is allowed only if the pH does not exceed 8.0. The pH may be lowered by adding sulfuric acid to the water. Dewatering of the collection area after treatment shall follow the criteria in [Section 3.3 Dewatering Controls](#).
- Care shall be exercised when treating the concrete washout water for discharge. Monitoring must be implemented to verify that discharges do not violate groundwater or surface water quality standards.
- On large projects that are using a nearby batch plant, a washout facility associated with the plant and under the plant's TPDES Multi-Sector General Permit may be used instead of installing an onsite containment area for truck washout.

Education

- Drivers and equipment operators should be instructed on proper disposal and equipment washing practices (see above).
- Supervisors must be made aware of the potential environmental consequences of improperly handled concrete waste.

Enforcement

- The construction site manager or foreman must ensure that employees and pre-mix companies follow proper procedures for concrete disposal and equipment washing.
- Employees violating disposal or equipment cleaning directives must be re-educated or disciplined if necessary.

Demolition Practices

- Monitor weather and wind direction to ensure concrete dust is not entering drainage structures and surface waters.
- Spray water on structures being demolished to wet them before start of demolition operations. Reapply water whenever dust is observed.
- Construct sediment traps or other types of sediment detention devices downstream of demolition activities to capture and treat runoff from demolition wetting operations.

4.3.4 *Design Guidance and Specifications*

No specification for concrete waste management is currently available in the Standard Specifications for Public Works – North Central Texas Council of Governemtns.

4.3.5 *Inspection and Maintenance Requirements*

Concrete waste management controls should be inspected regularly (at least as often as required by the TPDES Construction General Permit) for proper handling of concrete waste. Check concrete washout pits and make repairs as needed. Washout pits should not be allowed to overflow. Maintain a schedule to regularly remove concrete waste and prevent over-filling.

If illicit dumping of concrete is found, remove the waste and reinforce proper disposal methods through education of employees.

4.3.6 *Example Schematics*

The following schematics are example applications of the construction control. They are intended to assist in understanding the control's design and function.

The schematics are **not for construction**. They may serve as a starting point for creating a construction detail, but they must be site adapted by the designer. In addition, dimensions and notes appropriate for the application must be added by the designer.

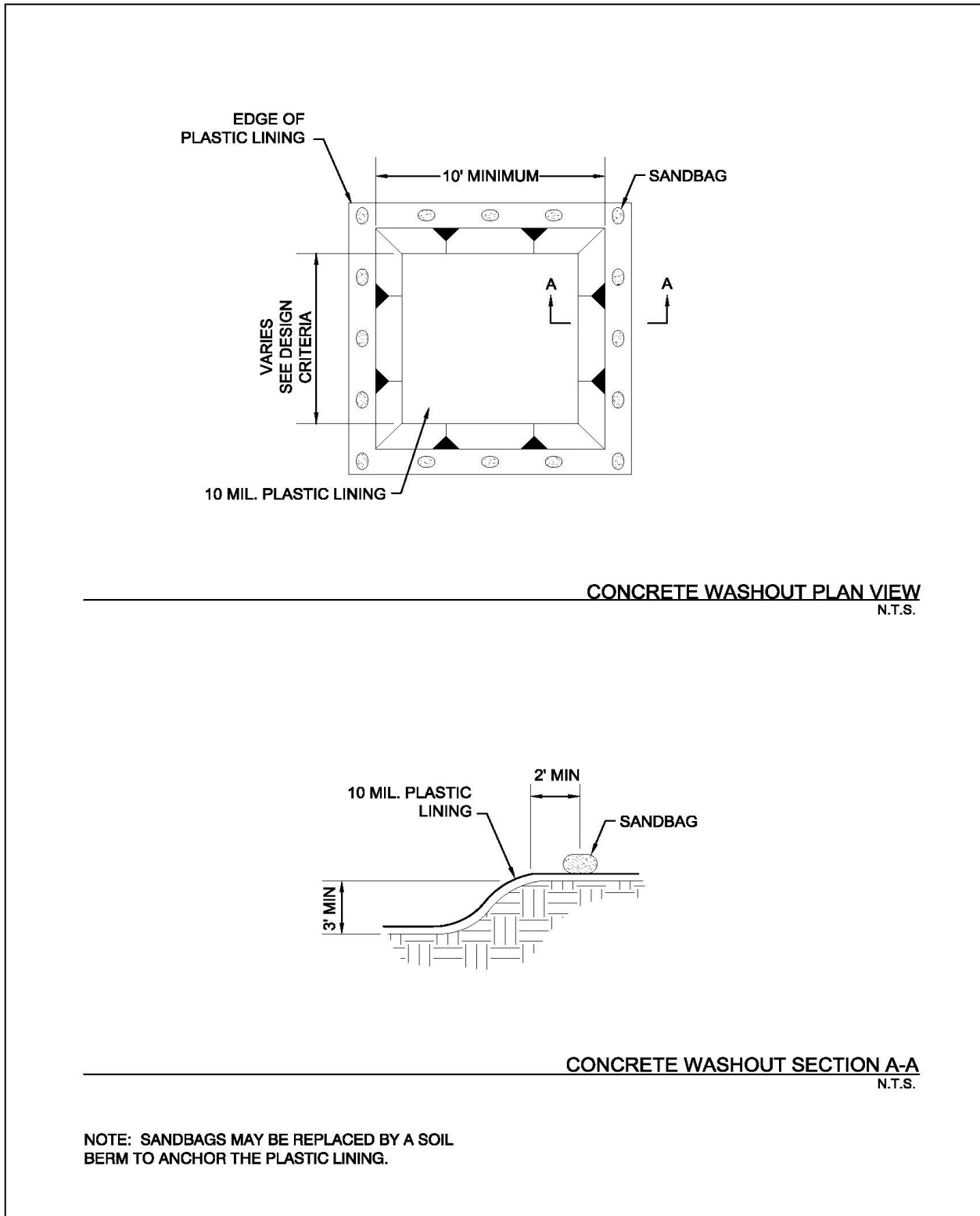

Figure 4.1 Schematics of Concrete Washout Containment

APPENDIX E

INSPECTION AND MAINTENANCE REPORTS

Inspector Qualifications*

Inspector Name: _____
Qualifications (Check as appropriate and provide description):
 Training Course _____
 Supervised Experience _____
 Other _____

Inspector Name: _____
Qualifications (Check as appropriate and provide description):
 Training Course _____
 Supervised Experience _____
 Other _____

Inspector Name: _____
Qualifications (Check as appropriate and provide description):
 Training Course _____
 Supervised Experience _____
 Other _____

**Personnel conducting inspections must be knowledgeable of the general permit, familiar with the construction site, and knowledgeable of the SWP3 for the site.*

MAINTENANCE GUIDELINES

1. Below are some maintenance practices to be used to maintain erosion and sediment controls:
 - All control measures will be inspected according to the schedule identified in Appendix E.
 - All measures will be maintained in good working order. The operator should correct any damage or deficiencies as soon as practicable after the inspection, but in no case later than seven (7) calendar days after the inspection.
 - BMP Maintenance (as applicable)
 - Sediment must be removed from sediment traps and sedimentation ponds no later than the time that design capacity has been reduced by 50%. For perimeter controls such as silt fences, berms, etc., the trapped sediment must be removed before it reaches 50% of the above-ground height.
 - Silt fence will be inspected for depth of sediment, tears, to see if the fabric is securely attached to the fence posts, and to see that the fence posts are firmly in the ground.
 - Drainage swale will be inspected and repaired as necessary.
 - Inlet control will be inspected and repaired as necessary.
 - Check dam will be inspected and repaired as necessary.
 - Straw bale dike will be inspected and repaired as necessary.
 - Diversion dike will be inspected and any breaches promptly repaired.
 - Temporary and permanent seeding and planting will be inspected for bare spots, washouts, and healthy growth.
 - If sediment escapes the site, accumulations must be removed at a frequency that minimizes off-site impacts, and prior to the next rain event, if feasible. If the permittee does not own or operate the off-site conveyance, then the permittee must work with the owner or operator of the property to remove the sediment.
 - Locations where vehicles enter or exit the site must be inspected for evidence of off-site sediment tracking.
2. To maintain the above practices, the following will be performed:
 - Maintenance and repairs will be conducted before the next anticipated storm event or as necessary to maintain the continued effectiveness of storm water controls. Following an inspection, deficiencies should be corrected no later than seven (7) calendar days after the inspection.
 - Any necessary revisions to the SWP3 as a result of the inspection must be completed within seven (7) calendar days following the inspection. If existing BMPs are modified or if additional BMPs are necessary, an implementation schedule must be described in the SWP3 and wherever possible those changes implemented before the next storm event.
 - Personnel selected for inspection and maintenance responsibilities must be knowledgeable of the general permit, familiar with the construction site, and knowledgeable of the SWP3 for the site.

APPENDIX F

ROLES AND RESPONSIBILITIES CHECKLIST AND CERTIFICATION STATEMENT

PRIMARY AND SECONDARY OPERATOR GENERAL RESPONSIBILITIES

DEFINITIONS:

Operator - The person or persons associated with a large or small construction activity that is either a primary or secondary operator as defined below:

Primary Operator – the person or persons associated with a large or small construction activity that meets either of the following two criteria:

- (a.) the person or persons have operational control over construction plans and specifications, including the ability to make modifications to those plans and specifications, or
- (b.) the person or persons have day-to-day operational control of those activities at a construction site that are necessary to ensure compliance with a storm water pollution prevention plan (SWP3) for the site or other permit conditions (e.g., they are authorized to direct workers at a site to carry out activities required by the SWP3 or comply with other permit conditions).

Secondary Operator – The person or entity, often the property owner, whose operational control is limited to:

- (a.) the employment of other operators, such as a general contractor, to perform or supervise construction activities; or
- (b.) the ability to approve or disapprove changes to construction plans and specifications, but who does not have day to day on-site.

Secondary operators must either prepare their own SWP3 or participate in a shared SWP3 that covers the areas of construction site, where they have control over the construction plans and specifications.

If there is not a primary operator at the construction site, then the secondary operator is defined as the primary operator and must comply with the permit requirements for primary operators.

Please note that both Owners and Contractors can meet the definition of being an Operator and will need to fulfill the associated requirements. The Roles and Responsibilities Checklist and Certification Statement located in Appendix F are to be completed and signed by the Owner and Contractor(s).

Secondary Operators and Primary Operators with Control Over Construction Plans and Specifications

All secondary operators and primary operators with control over construction plans and specifications must:

- (a.) ensure the project specifications allow or provide that adequate BMPs are developed to meet the requirements of the general permit,

- (b.) ensure that the SWP3 indicates the areas of the project where they have control over project specifications, including the ability to make modifications in specifications,
- (c.) ensure all other operators affected by modifications in project specifications are notified in a timely manner so that those operators may modify their best management practices as necessary to remain compliant with the conditions of this general permit, and
- (d.) ensure that the SWP3 for portions of the project where they are operators indicates the name and site-specific TPDES authorization numbers for permittees with the day-to-day operational control over those activities necessary to ensure compliance with the SWP3 and other permit conditions. If the party with day-to-day operational control has not been authorized or has abandoned the site, the person with control over project specifications is considered to be the responsible party until the authority is transferred to another party and the SWP3 is updated.

Primary Operators with Day-to-Day Operational Control

Primary Operators with day-to-day operational control of those activities at a project that are necessary to ensure compliance with the SWP3 and other permit conditions must ensure that the SWP3 accomplishes the following requirements:

- (a.) meets the requirements of the general permit for those portions of the project where they are operators,
- (b.) the parties responsible for implementation of BMPs described in the SWP3,
- (c.) indicates areas of the project where they have operational control over day-to-day activities, and
- (d.) includes, for areas where they have operational control over day-to-day activities, the name and site-specific TPDES authorization number of the parties with control over project specifications, including the ability to make modifications in specifications.

Roles and Responsibilities Checklist (NOI and NOT submittal not required for “Small Construction Project”)

Role/Responsibility	Project Owner*	Primary Operator	Secondary Operator
Development of initial design specifications			
Payment for proposed construction activity			
Maintain SWP3 records for three years from the date that the operator terminates coverage (small construction activity) or an NOI is submitted (large construction activity only)			
Complete, sign, and electronically submit NOI prior to the beginning of construction activity (large construction activity only)			
Post a copy of the signed NOI at project site and maintain through duration of project (large construction activity only)			
Post copy of completed and signed construction site notice(s) at project site through duration of project.			
Provide a copy of the completed site notice and/or signed NOI to any secondary operator and to the operator of any MS4 receiving construction site discharge, at least two days prior to commencing construction activities.			
Maintain schedule of major construction activities, keep a copy with SWP3, and retain a copy of the SWP3 at the construction site at all times			
Update SWP3 to reflect daily operations (e.g., revisions, installation dates, grading operation dates, BMP maintenance, and inspection information)			
Update SWP3 to reflect changes in the Contractor’s contact information			
Identify, maintain and modify BMPs (as necessary) to control erosion and sedimentation due to construction activities throughout life of project			
Provide stabilized construction entrances and sediment barriers, and clean existing rock and/or add rock to prevent mud and dirt from entering streets or alleys			
Maintain and/or replace sediment barriers and silt traps (if installed), etc. throughout life of project			
Maintain erosion control on stockpiles without blocking drainage paths			
Perform SWP3 inspections in accordance with TPDES General Permit, and keep inspection reports with SWP3			
Based on inspection results, modify SWP3 and pollution prevention controls to maintain that storm water (or identified non-storm water discharges) are the only discharges leaving the site			

Role/Responsibility	Project Owner*	Primary Operator	Secondary Operator
Provide proper management of project-generated trash and debris, including debris collected from storm water protection devices			
Stabilize all disturbed areas related to construction for temporary or permanent ceasing of activities			
Comply with all State and local sanitary sewer or septic system regulations			
Provide copies of all SWP3 records to the Project Owner			
Complete, sign, and submit NOT form to the TCEQ and MS4 Operators when the project has been completed and stabilized (large construction activity only)			
Complete applicable portion of the site notice related to removal of the notice and submit to the operator of any MS4 receiving site discharge			

**Please note that the Project Owner can meet the definition of an operator. Please refer to the definitions of "primary operator" and "secondary operator" for more information.*

Each operator engaged in activities that disturb surface soils must be identified and must sign the following certification statement. Signatory requirement guidance and an additional certification statement form are attached (Appendix F).

Certification Statement:

"I certify under penalty of law that this document and all attachments were prepared under my direction or supervision in accordance with a system designed to assure that qualified personnel properly gather and evaluate the information submitted. Based on my inquiry of the person or persons who manage the system, or those persons directly responsible for gathering the information, the information submitted is, to the best of my knowledge and belief, true, accurate, and complete. I am aware there are significant penalties for submitting false information, including the possibility of fine and imprisonment for knowing violations.

I further certify that I am authorized under 30 Texas Administrative Code §305.44 to sign this document and can provide documentation in proof of such authorization upon request."

Project Owner

Name: _____
 Title: _____
 Company: _____
 Signature: _____
 Date: _____
 Operator Type: _____

General Contractor

Name: _____
 Title: _____
 Company: _____
 Signature: _____
 Date: _____
 Operator Type: _____

Subcontractor (as appropriate)

Name: _____
 Title: _____
 Company: _____
 Signature: _____
 Date: _____
 Operator Type: _____

Subcontractor (as appropriate)

Name: _____
 Title: _____
 Company: _____
 Signature: _____
 Date: _____
 Operator Type: _____

NOTICE OF INTENT (NOI) LOG			
Name	Company	Date Submitted NOI	TPDES Permit No.

Signature Requirements in 30 TAC §305.44

The purpose of this document is to clarify the signature requirements for water quality permit applications subject to 30 Texas Administrative Code (TAC) section (§)305.44. This includes most applications relating to authorizations issued under 30 TAC Chapter 305 (relating to Consolidated Permits), Chapter 205 (relating to General Permits for Waste Discharges), 30 TAC Chapter 312 (relating to Sludge Use, Disposal and Transportation), and 30 TAC Chapter 321 (relating to Control of Certain Activities By Rule).

TCEQ is currently updating the signatory instructions in its application forms. You may have recently received a notice of deficiency (NOD) letter indicating failure to meet the signatory requirements. Please review the information provided below concerning signatory requirements and have a person authorized to sign under §305.44 and submit the enclosed certification. The certification must clearly indicate the applicant and the original application form subject to the NOD. Upon satisfactory review of your signed certification, your submission will no longer be deficient for failing to meet the signatory requirements.

You are encouraged to use the attached certification page for water quality permit and registration applications, and other authorization forms subject to §305.44, until the forms have been updated.

IF YOU ARE A CORPORATION:

The regulation governing who may sign an application form is 30 TAC §305.44(a)(1) (see attached). According to this provision, any corporate representative may sign an application form so long as the authority to sign such a document has been delegated to that person in accordance with corporate procedures. By signing the application form, you are certifying that such authority has been delegated to you. The TCEQ may request documentation evidencing such authority.

IF YOU ARE A MUNICIPALITY OR OTHER GOVERNMENT ENTITY:

The regulation governing who may sign an application form is 30 Texas Administrative Code §305.44(a)(3) (see attached). According to this provision, only a ranking elected official or principal executive officer may sign an application form. Persons such as the City Mayor or County Commissioner are ranking elected officials. The principal executive officer may be identified in your city charter, county or city ordinances, or the Texas statute(s) under which your governmental entity was formed. An application form that is signed by a governmental official who is not a ranking elected official or principal executive officer does not conform to §305.44(a)(3). The signatory requirement may not be delegated to a government representative other than those identified in the regulation. By signing the application, you are certifying that you are either a ranking elected official or principal executive officer. Documentation demonstrating your position as a ranking elected official or principal executive officer may be requested by the TCEQ.

If you have questions or need additional information concerning the signatory requirements discussed above, please contact either Matt Beeter at (512) 239-1406 or Carol Lear at (512) 239-1025, of the Texas Commission on Environmental Quality's Environmental Law Division.

30 Texas Administrative Code
§305.44. Signatories to Applications.

(a) All applications shall be signed as follows.

(1) For a corporation, the application shall be signed by a responsible corporate officer. For purposes of this paragraph, a responsible corporate officer means a president, secretary, treasurer, or vice-president of the corporation in charge of a principal business function, or any other person who performs similar policy or decision-making functions for the corporation; or the manager of one or more manufacturing, production, or operating facilities employing more than 250 persons or having gross annual sales or expenditures exceeding \$25 million (in second-quarter 1980 dollars), if authority to sign documents has been assigned or delegated to the manager in accordance with corporate procedures. Corporate procedures governing authority to sign permit or post-closure order applications may provide for assignment or delegation to applicable corporate positions rather than to specific individuals.

(2) For a partnership or sole proprietorship, the application shall be signed by a general partner or the proprietor, respectively.

(3) For a municipality, state, federal, or other public agency, the application shall be signed by either a principal executive officer or a ranking elected official. For purposes of this paragraph, a principal executive officer of a federal agency includes the chief executive officer of the agency, or a senior executive officer having responsibility for the overall operations of a principal geographic unit of the agency (e.g., regional administrator of the EPA).

CERTIFICATION

Permit/Registration No. _____

Applicant: _____

I, _____
Typed or printed name *Title*

certify under penalty of law that this document and all attachments were prepared under my direction or supervision in accordance with a system designed to assure that qualified personnel properly gather and evaluate the information submitted. Based on my inquiry of the person or persons who manage the system, or those persons directly responsible for gathering the information, the information submitted is, to the best of my knowledge and belief, true, accurate, and complete. I am aware there are significant penalties for submitting false information, including the possibility of fine and imprisonment for knowing violations.

I further certify that I am authorized under 30 Texas Administrative Code §305.44 to sign this document and can provide documentation in proof of such authorization upon request.

Signature: _____ Date: _____

APPENDIX G

TPDES GENERAL PERMIT (TXR150000) FOR
STORM WATER DISCHARGES FROM
CONSTRUCTION ACTIVITIES

Texas Commission on Environmental Quality

P.O. Box 13087, Austin, Texas 78711-3087



GENERAL PERMIT TO DISCHARGE UNDER THE TEXAS POLLUTANT DISCHARGE ELIMINATION SYSTEM

under provisions of
Section 402 of the Clean Water Act
and Chapter 26 of the Texas Water Code

This permit supersedes and replaces
TPDES General Permit No. TXR150000,
effective March 5, 2018, and amended January 28, 2022

Construction sites that discharge stormwater associated with construction activity located in the state of Texas may discharge to surface water in the state only according to monitoring requirements and other conditions set forth in this general permit, as well as the rules of the Texas Commission on Environmental Quality (TCEQ or Commission), the laws of the State of Texas, and other orders of the Commission of the TCEQ. The issuance of this general permit does not grant to the permittee the right to use private or public property for conveyance of stormwater and certain non-stormwater discharges along the discharge route. This includes property belonging to but not limited to any individual, partnership, corporation or other entity. Neither does this general permit authorize any invasion of personal rights nor any violation of federal, state, or local laws or regulations. It is the responsibility of the permittee to acquire property rights as may be necessary to use the discharge route.

This general permit and the authorization contained herein shall expire at midnight, on March 5, 2028.

EFFECTIVE DATE: March 5, 2023

ISSUED DATE: February 27, 2023

For the Commission

**TPDES GENERAL PERMIT NUMBER TXR150000
RELATING TO STORMWATER DISCHARGES ASSOCIATED WITH
CONSTRUCTION ACTIVITIES**

Table of Contents

Part I. Flow Chart and Definitions5

Section A. Flow Chart to Determine Whether Coverage is Required5

Section B. Definitions.....6

Part II. Permit Applicability and Coverage 12

Section A. Discharges Eligible for Authorization 12

1. Stormwater Associated with Construction Activity 12

2. Discharges of Stormwater Associated with Construction Support Activities 12

3. Non-Stormwater Discharges 12

4. Other Permitted Discharges 13

Section B. Concrete Truck Wash Out 13

Section C. Limitations on Permit Coverage 13

1. Post Construction Discharges 13

2. Prohibition of Non-Stormwater Discharges 13

3. Compliance with Water Quality Standards 14

4. Impaired Receiving Waters and Total Maximum Daily Load (TMDL) Requirements
..... 14

5. Discharges to the Edwards Aquifer Recharge or Contributing Zone 14

6. Discharges to Specific Watersheds and Water Quality Areas 15

7. Protection of Streams and Watersheds by Other Governmental Entities..... 15

8. Indian Country Lands 15

9. Exempt Oil and Gas Activities 15

10. Stormwater Discharges from Agricultural Activities..... 16

11. Endangered Species Act..... 16

12. Storage of High-Level Radioactive Waste 16

13. Other 17

Section D. Deadlines for Obtaining Authorization to Discharge 17

1. Large Construction Activities 17

2. Small Construction Activities 17

Section E. Obtaining Authorization to Discharge 17

1. Automatic Authorization for Small Construction Activities with Low Potential for
Erosion..... 17

2. Automatic Authorization for Small Construction Activities..... 18

3.	Authorization for Large Construction Activities	19
4.	Waivers for Small Construction Activities:.....	21
5.	Effective Date of Coverage	21
6.	Contents of the NOI	22
7.	Notice of Change (NOC)	22
8.	Signatory Requirement for NOI Forms, NOT Forms, NOC Forms, and Construction Site Notices	23
Section F. Terminating Coverage.....		24
1.	Notice of Termination (NOT) Required	24
2.	Minimum Contents of the NOT	24
3.	Termination of Coverage for Small Construction Sites and for Secondary Operators at Large Construction Sites.....	25
4.	Transfer of Day-to-Day Operational Control.....	25
Section G. Waivers from Coverage		26
1.	Waiver Applicability and Coverage.....	26
2.	Steps to Obtaining a Waiver	27
3.	Effective Date of an LREW	27
4.	Activities Extending Beyond the LREW Period.....	28
Section H. Alternative TPDES Permit Coverage.....		28
1.	Individual Permit Alternative	28
2.	General Permit Alternative	28
3.	Individual Permit Required	28
Section I. Permit Expiration.....		29
Part III. Stormwater Pollution Prevention Plans (SWP ₃)		29
Section A. Shared SWP ₃ Development		30
Section B. Responsibilities of Operators		30
1.	Secondary Operators and Primary Operators with Control Over Construction Plans and Specifications	30
2.	Primary Operators with Day-to-Day Operational Control	31
Section C. Deadlines for SWP ₃ Preparation, Implementation, and Compliance.....		31
Section D. Plan Review and Making Plans Available		31
Section E. Revisions and Updates to SWP ₃ s		32
Section F. Contents of SWP ₃		32
Part IV. Erosion and Sediment Control Requirements Applicable to All Sites.....		43
Section A. Erosion and Sediment Controls		43
Section B. Soil Stabilization		44
Section C. Dewatering		44

Section D. Pollution Prevention Measures44

Section E. Prohibited Discharges45

Section F. Surface Outlets45

Part V. Stormwater Runoff from Concrete Batch Plants45

Section A. Benchmark Sampling Requirements46

Section B. Best Management Practices (BMPs) and SWP3 Requirements47

Section C. Prohibition of Wastewater Discharges.....50

Part VI. Concrete Truck Wash Out Requirements50

Part VII. Retention of Records.....50

Part VIII. Standard Permit Conditions..... 51

Part IX. Fees.....52

Appendix A: Automatic Authorization53

Appendix B: Storm Erosivity (EI) Zones in Texas55

Appendix C: Isoerodent Map56

Appendix D: Erosivity Indices for EI Zones in Texas 57

Part I. Flow Chart and Definitions

Section A. Flow Chart to Determine Whether Coverage is Required

When calculating the acreage of land area disturbed, include the disturbed land-area of all construction and construction support activities.

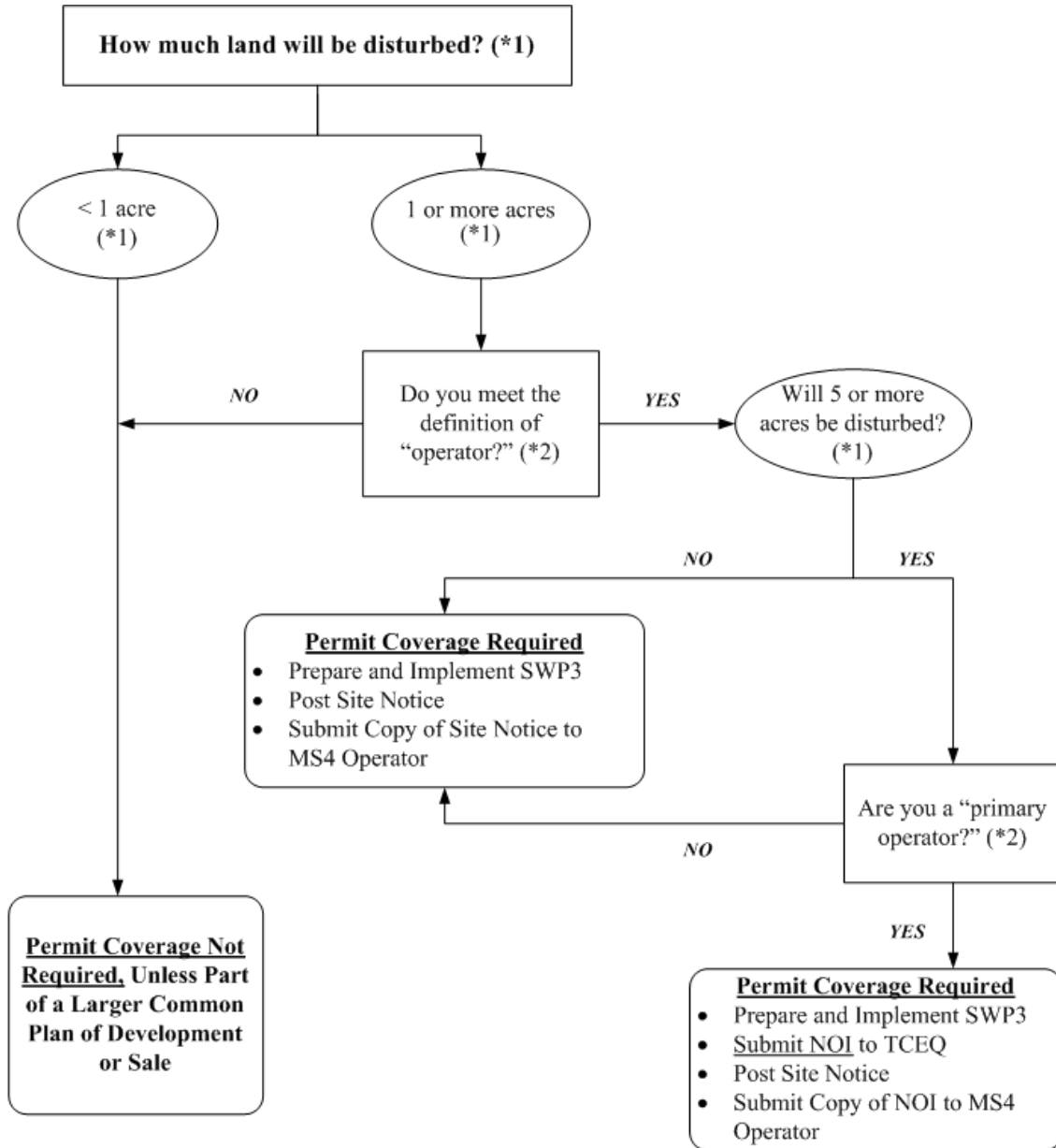

(*1) To determine the size of the construction project, use the size of the entire area to be disturbed, and include the size of the larger common plan of development or sale, if the project is part of a larger project (refer to Part I.B., "Definitions," for an explanation of "common plan of development or sale").

(*2) Refer to the definitions for "operator," "primary operator," and "secondary operator" in Part I., Section B. of this permit.

Section B. Definitions

Arid Areas – Areas with an average annual rainfall of zero (0) to ten (10) inches.

Best Management Practices (BMPs) – Schedules of activities, prohibitions of practices, maintenance procedures, structural controls, local ordinances, and other management practices to prevent or reduce the discharge of pollutants. BMPs also include treatment requirements, operating procedures, and practices to control construction site runoff, spills or leaks, waste disposal, or drainage from raw material storage areas.

Commencement of Construction – The initial disturbance of soils associated with clearing, grading, or excavation activities, as well as other construction-related activities (e.g., demolition; grubbing; stockpiling of fill material; placement of raw materials at the site).

Common Plan of Development – A construction activity that is completed in separate stages, separate phases, or in combination with other construction activities. A common plan of development (also known as a “common plan of development or sale”) is identified by the documentation for the construction project that identifies the scope of the project, and may include plats, blueprints, marketing plans, contracts, building permits, a public notice or hearing, zoning requests, or other similar documentation and activities. A common plan of development does not necessarily include all construction projects within the jurisdiction of a public entity (e.g., a city or university). Construction of roads or buildings in different parts of the jurisdiction would be considered separate “common plans,” with only the interconnected parts of a project being considered part of a “common plan” (e.g., a building and its associated parking lot and driveways, airport runway and associated taxiways, a building complex, etc.). Where discrete construction projects occur within a larger common plan of development or sale but are located one quarter (1/4) mile or more apart, and the area between the projects is not being disturbed, each individual project can be treated as a separate plan of development or sale, provided that any interconnecting road, pipeline or utility project that is part of the same “common plan” is not included in the area to be disturbed.

Construction Activity – Includes soil disturbance activities, including clearing, grading, excavating, construction-related activity (e.g., stockpiling of fill material, demolition), and construction support activity. This does not include routine maintenance that is performed to maintain the original line and grade, hydraulic capacity, or original purpose of the site (e.g., the routine grading of existing dirt roads, asphalt overlays of existing roads, the routine clearing of existing rights-of-way, and similar maintenance activities). Regulated construction activity is defined in terms of small and large construction activity.

Construction Support Activity – A construction-related activity that specifically supports construction activity, which can involve earth disturbance or pollutant-generating activities of its own, and can include, but are not limited to, activities associated with concrete or asphalt batch plants, rock crushers, equipment staging or storage areas, chemical storage areas, material storage areas, material borrow areas, and excavated material disposal areas. Construction support activity must only directly support the construction activity authorized under this general permit.

Dewatering – The act of draining accumulated stormwater or groundwater from building foundations, vaults, trenches, and other similar points of accumulation.

Discharge – For the purposes of this permit, the drainage, release, or disposal of pollutants in stormwater and certain non-stormwater from areas where soil disturbing activities (e.g., clearing, grading, excavation, stockpiling of fill material, and demolition), construction materials or equipment storage or maintenance (e.g., fill piles, borrow area, concrete truck wash out, fueling), or other industrial stormwater directly related to the construction process (e.g., concrete or asphalt batch plants) are located.

Drought-Stricken Area – For the purposes of this permit, an area in which the National Oceanic and Atmospheric Administration’s U.S. Seasonal Drought Outlook indicates for the period during which the construction will occur that any of the following conditions are likely: (1) “Drought to persist or intensify”, (2) “Drought ongoing, some improvement”, (3) “Drought likely to improve, impacts ease”, or (4) “Drought development likely”. See http://www.cpc.ncep.noaa.gov/products/expert_assessment/seasonal_drought.html.

Edwards Aquifer – As defined under Texas Administrative Code (TAC) § 213.3 of this title (relating to the Edwards Aquifer), that portion of an arcuate belt of porous, water-bearing, predominantly carbonate rocks known as the Edwards and Associated Limestones in the Balcones Fault Zone trending from west to east to northeast in Kinney, Uvalde, Medina, Bexar, Comal, Hays, Travis, and Williamson Counties; and composed of the Salmon Peak Limestone, McKnight Formation, West Nueces Formation, Devil’s River Limestone, Person Formation, Kainer Formation, Edwards Formation, and Georgetown Formation. The permeable aquifer units generally overlie the less-permeable Glen Rose Formation to the south, overlie the less-permeable Comanche Peak and Walnut Formations north of the Colorado River, and underlie the less-permeable Del Rio Clay regionally.

Edwards Aquifer Recharge Zone – Generally, that area where the stratigraphic units constituting the Edwards Aquifer crop out, including the outcrops of other geologic formations in proximity to the Edwards Aquifer, where caves, sinkholes, faults, fractures, or other permeable features would create a potential for recharge of surface waters into the Edwards Aquifer. The recharge zone is identified as that area designated as such on official maps located in the offices of the Texas Commission on Environmental Quality (TCEQ) and the appropriate regional office. The Edwards Aquifer Map Viewer, located at <https://www.tceq.texas.gov/gis/edwards-viewer.html>

Edwards Aquifer Contributing Zone – The area or watershed where runoff from precipitation flows downgradient to the recharge zone of the Edwards Aquifer. The contributing zone is located upstream (upgradient) and generally north and northwest of the recharge zone for the following counties: all areas within Kinney County, except the area within the watershed draining to Segment No. 2304 of the Rio Grande Basin; all areas within Uvalde, Medina, Bexar, and Comal Counties; all areas within Hays and Travis Counties, except the area within the watersheds draining to the Colorado River above a point 1.3 miles upstream from Tom Miller Dam, Lake Austin at the confluence of Barrow Brook Cove, Segment No. 1403 of the Colorado River Basin; and all areas within Williamson County, except the area within the watersheds draining to the Lampasas River above the dam at Stillhouse Hollow reservoir, Segment No. 1216 of the Brazos River Basin. The contributing zone is illustrated on the Edwards Aquifer map viewer at <https://www.tceq.texas.gov/gis/edwards-viewer.html>

Effluent Limitations Guideline (ELG) – Defined in 40 Code of Federal Regulations (CFR) § 122.2 as a regulation published by the Administrator under § 304(b) of the Clean Water Act (CWA) to adopt or revise effluent limitations.

Facility or Activity – For the purpose of this permit, referring to a construction site, the location of construction activity, or a construction support activity that is regulated under this general permit, including all contiguous land and fixtures (for example, ponds and materials stockpiles), structures, or appurtenances used at a construction site or industrial site.

Final Stabilization – A construction site status where any of the following conditions are met:

- (a) All soil disturbing activities at the site have been completed and a uniform (that is, evenly distributed, without large bare areas) perennial vegetative cover with a density of at least 70% of the native background vegetative cover for the area has been established on all unpaved areas and areas not covered by permanent structures, or equivalent permanent stabilization measures (such as the use of riprap, or gabions) have been employed.
- (b) For individual lots in a residential construction site by either:
 - (1) the homebuilder completing final stabilization as specified in condition (a) above; or
 - (2) the homebuilder establishing temporary stabilization for an individual lot prior to the time of transfer of the ownership of the home to the buyer and after informing the homeowner of the need for, and benefits of, final stabilization. If temporary stabilization is not feasible, then the homebuilder may fulfill this requirement by retaining perimeter controls or BMPs, and informing the homeowner of the need for removal of temporary controls and the establishment of final stabilization. Fulfillment of this requirement must be documented in the homebuilder's stormwater pollution prevention plan (SWP3).
- (c) For construction activities on land used for agricultural purposes (such as pipelines across crop or range land), final stabilization may be accomplished by returning the disturbed land to its preconstruction agricultural use. Areas disturbed that were not previously used for agricultural activities, such as buffer strips immediately adjacent to surface water and areas that are not being returned to their preconstruction agricultural use must meet the final stabilization conditions of condition (a) above.
- (d) In arid, semi-arid, and drought-stricken areas only, all soil disturbing activities at the site have been completed and both of the following criteria have been met:
 - (1) temporary erosion control measures (for example, degradable rolled erosion control product) are selected, designed, and installed along with an appropriate seed base to provide erosion control for at least three years without active maintenance by the operator, and
 - (2) the temporary erosion control measures are selected, designed, and installed to achieve 70% of the native background vegetative coverage within three years.

High-Level Radioactive Waste – Meaning as assigned by 42 United States Code (U.S.C.) Section 10101 (12) and includes spent nuclear fuel as defined by 42 U.S.C. Section 10101 (23).

Hyperchlorination of Waterlines – Treatment of potable water lines or tanks with chlorine for disinfection purposes, typically following repair or partial replacement of the waterline or tank, and subsequently flushing the contents.

Impaired Water – A surface water body that is identified as impaired on the latest approved CWA § 303(d) List or waters with an EPA-approved or established total maximum daily load (TMDL) that are found on the latest EPA approved *Texas Integrated Report of Surface Water Quality for CWA Sections 305(b) and 303(d)*, which lists the category 4 and 5 water bodies.

Indian Country Land – (1) All land within the limits of any Indian reservation under the jurisdiction of the United States government, notwithstanding the issuance of any patent, and, including rights-of-way running through the reservation; (2) all dependent Indian communities with the borders of the United States whether within the originally or subsequently acquired territory thereof, and whether within or without the limits of a state; and (3) all Indian allotments, the Indian titles to which have not been extinguished, including rights-of-way running through the same. (40 CFR § 122.2)

Indian Tribe – Any Indian Tribe, band, group, or community recognized by the Secretary of the Interior and exercising governmental authority over a Federal Indian Reservation (40 CFR § 122.2).

Infeasible – Not technologically possible, or not economically practicable and achievable in light of best industry practices. (40 CFR § 450.11(b)).

Large Construction Activity – Construction activities including clearing, grading, and excavating that result in land disturbance of equal to or greater than five (5) acres of land. Large construction activity also includes the disturbance of less than five (5) acres of total land area that is part of a larger common plan of development or sale if the larger common plan will ultimately disturb equal to or greater than five (5) acres of land. Large construction activity does not include routine maintenance that is performed to maintain the original line and grade, hydraulic capacity, or original purpose of the site (for example, the routine grading of existing dirt roads, asphalt overlays of existing roads, the routine clearing of existing right-of-ways, and similar maintenance activities).

Linear Project – Includes the construction of roads, bridges, conduits, substructures, pipelines, sewer lines, towers, poles, cables, wires, connectors, switching, regulating and transforming equipment and associated ancillary facilities in a long, narrow area.

Low Rainfall Erosivity Waiver (LREW) – A written submission to the executive director from an operator of a construction site that is considered as small construction activity under the permit, which qualifies for a waiver from the requirements for small construction activities, only during the period of time when the calculated rainfall erosivity factor is less than five (5).

Minimize – To reduce or eliminate to the extent achievable using stormwater controls that are technologically available and economically practicable and achievable in light of best industry practices.

Municipal Separate Storm Sewer System (MS4) – A separate storm sewer system owned or operated by the United States, a state, city, town, county, district, association, or other public body (created by or pursuant to state law) having jurisdiction over the disposal of sewage, industrial wastes, stormwater, or other wastes, including special districts under state law such as a sewer district, flood control or drainage district, or similar entity, or an Indian tribe or an authorized Indian tribal organization, that discharges to surface water in the state.

Notice of Change (NOC) – Written notification to the executive director from a discharger authorized under this permit, providing changes to information that was previously provided to the agency in a notice of intent form.

Notice of Intent (NOI) – A written submission to the executive director from an applicant requesting coverage under this general permit.

Notice of Termination (NOT) – A written submission to the executive director from a discharger authorized under this general permit requesting termination of coverage.

Operator – The person or persons associated with a large or small construction activity that is either a primary or secondary operator as defined below:

Primary Operator – The person or persons associated with construction activity that meets either of the following two criteria:

- (a) the person or persons have on-site operational control over construction plans and specifications, including the ability to make modifications to those plans and specifications; or

- (b) the person or persons have day-to-day operational control of those activities at a construction site that are necessary to ensure compliance with a Stormwater Pollution Prevention Plan (SWP3) for the site or other permit conditions (for example, they are authorized to direct workers at a site to carry out activities required by the SWP3 or comply with other permit conditions).

Secondary Operator – The person or entity, often the property owner, whose operational control is limited to:

- (a) the employment of other operators, such as a general contractor, to perform or supervise construction activities; or
- (b) the ability to approve or disapprove changes to construction plans and specifications, but who does not have day-to-day on-site operational control over construction activities at the site.

Secondary operators must either prepare their own SWP3 or participate in a shared SWP3 that covers the areas of the construction site, where they have control over the construction plans and specifications.

If there is not a primary operator at the construction site, then the secondary operator is defined as the primary operator and must comply with the requirements for primary operators.

Outfall – For the purpose of this permit, a point source at the point where stormwater runoff associated with construction activity discharges to surface water in the state and does not include open conveyances connecting two municipal separate storm sewers, or pipes, tunnels, or other conveyances that connect segments of the same stream or other water of the U.S. and are used to convey waters of the U.S.

Permittee – An operator authorized under this general permit. The authorization may be gained through submission of a notice of intent, by waiver, or by meeting the requirements for automatic coverage to discharge stormwater runoff and certain non-stormwater discharges from construction activity.

Point Source – Any discernible, confined, and discrete conveyance, including but not limited to, any pipe, ditch, channel, tunnel, conduit, well, discrete fissure, container, rolling stock concentrated animal feeding operation, landfill leachate collection system, vessel or other floating craft from which pollutants are, or may be, discharged. This term does not include return flows from irrigated agriculture or agricultural stormwater runoff (40 CFR § 122.2).

Pollutant – Dredged spoil, solid waste, incinerator residue, sewage, garbage, sewage sludge, filter backwash, munitions, chemical wastes, biological materials, radioactive materials, heat, wrecked or discarded equipment, rock, sand, cellar dirt, and industrial, municipal, and agricultural waste discharged into any surface water in the state. The term "pollutant" does not include tail water or runoff water from irrigation or rainwater runoff from cultivated or uncultivated rangeland, pastureland, and farmland. For the purpose of this permit, the term "pollutant" includes sediment.

Pollution – The alteration of the physical, thermal, chemical, or biological quality of, or the contamination of, any surface water in the state that renders the water harmful, detrimental, or injurious to humans, animal life, vegetation, or property or to public health, safety, or welfare, or impairs the usefulness or the public enjoyment of the water for any lawful or reasonable purpose (Texas Water Code (TWC) § 26.001(14)).

Rainfall Erosivity Factor (R factor) – The total annual erosive potential that is due to climatic effects, and is part of the Revised Universal Soil Loss Equation (RUSLE).

Receiving Water – A “Water of the United States” as defined in 40 CFR § 122.2 or a surface water in the state into which the regulated stormwater discharges.

Semi-arid Areas – Areas with an average annual rainfall of 10 to 20 inches.

Separate Storm Sewer System – A conveyance or system of conveyances (including roads with drainage systems, streets, catch basins, curbs, gutters, ditches, man-made channels, or storm drains), designed or used for collecting or conveying stormwater; that is not a combined sewer, and that is not part of a publicly owned treatment works (POTW).

Small Construction Activity – Construction activities including clearing, grading, and excavating that result in land disturbance of equal to or greater than one (1) acre and less than five (5) acres of land. Small construction activity also includes the disturbance of less than one (1) acre of total land area that is part of a larger common plan of development or sale if the larger common plan will ultimately disturb equal to or greater than one (1) and less than five (5) acres of land. Small construction activity does not include routine maintenance that is performed to maintain the original line and grade, hydraulic capacity, or original purpose of the site (for example, the routine grading of existing dirt roads, asphalt overlays of existing roads, the routine clearing of existing right-of-ways, and similar maintenance activities).

Steep Slopes – Where a state, Tribe, local government, or industry technical manual (e.g., stormwater BMP manual) has defined what is to be considered a “steep slope”, this permit’s definition automatically adopts that definition. Where no such definition exists, steep slopes are automatically defined as those that are 15 percent or greater in grade.

Stormwater (or Stormwater Runoff) – Rainfall runoff, snow melt runoff, and surface runoff and drainage.

Stormwater Associated with Construction Activity – Stormwater runoff, as defined above, from a construction activity.

Structural Control (or Practice) – A pollution prevention practice that requires the construction of a device, or the use of a device, to reduce or prevent pollution in stormwater runoff. Structural controls and practices may include but are not limited to: silt fences, earthen dikes, drainage swales, sediment traps, check dams, subsurface drains, storm drain inlet protection, rock outlet protection, reinforced soil retaining systems, gabions, and temporary or permanent sediment basins.

Surface Water in the State – Lakes, bays, ponds, impounding reservoirs, springs, rivers, streams, creeks, estuaries, wetlands, marshes, inlets, canals, the Gulf of Mexico inside the territorial limits of the state (from the mean high water mark (MHW) out 10.36 miles into the Gulf), and all other bodies of surface water, natural or artificial, inland or coastal, fresh or salt, navigable or non-navigable, and including the beds and banks of all water-courses and bodies of surface water, that are wholly or partially inside or bordering the state or subject to the jurisdiction of the state; except that waters in treatment systems which are authorized by state or federal law, regulation, or permit, and which are created for the purpose of waste treatment are not considered to be water in the state.

Temporary Stabilization – A condition where exposed soils or disturbed areas are provided a protective cover or other structural control to prevent the migration of pollutants. Temporary stabilization may include temporary seeding, geotextiles, mulches, and other techniques to reduce or eliminate erosion until either permanent stabilization can be achieved or until further construction activities take place.

Thawing Conditions – For the purposes of this permit, thawing conditions are expected based on the historical likelihood of two (2) or more days with daytime temperatures greater than 32 degrees Fahrenheit (°F). This date can be determined by looking at historical weather data.

NOTE: The estimation of thawing conditions is for planning purposes only. During construction, the permittee will be required to conduct site inspections based upon actual conditions (i.e., if thawing conditions occur sooner than expected, the permittee will be required to conduct inspections at the regular frequency).

Total Maximum Daily Load (TMDL) – The total amount of a pollutant that a water body can assimilate and still meet the Texas Surface Water Quality Standards.

Turbidity – A condition of water quality characterized by the presence of suspended solids and/or organic material.

Waters of the United States – Waters of the United States or waters of the U.S. means the term as defined in 40 CFR § 122.2.

Part II. Permit Applicability and Coverage

Section A. Discharges Eligible for Authorization

1. Stormwater Associated with Construction Activity

Discharges of stormwater runoff and certain non-stormwater discharges from small and large construction activities may be authorized under this general permit, except as described in Part II.C. of this permit.

2. Discharges of Stormwater Associated with Construction Support Activities

Discharges of stormwater runoff and certain non-stormwater discharges from construction support activities as defined in Part I.B. of this general permit may be authorized, provided that the following conditions are met:

- (a) the construction support activities are located within one (1) mile from the boundary of the construction site where the construction activity authorized under the permit is being conducted that requires the support of these activities;
- (b) an SWP₃ is developed and implemented for the permitted construction site according to the provisions in Part III.F. of this general permit, including appropriate controls and measures to reduce erosion and the discharge of pollutants in stormwater runoff according to the provisions in Part IV. of this general permit;
- (c) the activities are directly related to the construction site;
- (d) the activities are not a commercial operation, nor serve other unrelated construction projects; and
- (e) the activities do not continue to operate beyond the completion of the construction activity at the project it supports.

Construction support activities that operate outside the terms provided in (a) through (e) above must obtain authorization under a separate Texas Pollutant Discharge Elimination System (TPDES) permit, which may include the TPDES Multi-Sector General Permit (MSGP), TXR050000 (related to stormwater discharges associated with industrial activity), an alternative general permit (if available), or an individual water quality permit.

3. Non-Stormwater Discharges

The following non-stormwater discharges from sites authorized under this general permit are also eligible for authorization under this general permit:

- (a) discharges from emergency fire-fighting activities (emergency fire-fighting activities do not include washing of trucks, run-off water from training activities, test water from fire suppression systems, or similar activities);
 - (b) uncontaminated fire hydrant flushings (excluding discharges of hyperchlorinated water, unless the water is first dechlorinated and discharges are not expected to adversely affect aquatic life), which include flushings from systems that utilize potable water, surface water, or groundwater that does not contain additional pollutants (uncontaminated fire hydrant flushings do not include systems utilizing reclaimed wastewater as a source water);
 - (c) water from the routine external washing of vehicles, the external portion of buildings or structures, and pavement, where solvents, detergents, and soaps are not used, where spills or leaks of toxic or hazardous materials have not occurred (unless spilled materials have been removed; and if local state, or federal regulations are applicable, the materials are removed according to those regulations), and where the purpose is to remove mud, dirt, or dust;
 - (d) uncontaminated water used to control dust;
 - (e) potable water sources, including waterline flushings, but excluding discharges of hyperchlorinated water, unless the water is first dechlorinated and discharges are not expected to adversely affect aquatic life;
 - (f) uncontaminated air conditioning condensate;
 - (g) uncontaminated ground water or spring water, including foundation or footing drains where flows are not contaminated with industrial materials such as solvents; and
 - (h) lawn watering and similar irrigation drainage.
4. Other Permitted Discharges

Any discharge authorized under a separate National Pollutant Discharge Elimination System (NPDES), TPDES, or TCEQ permit may be combined with discharges authorized by this general permit, provided those discharges comply with the associated permit.

Section B. Concrete Truck Wash Out

The wash out of concrete trucks at regulated construction sites must be performed in accordance with the requirements of Part VI of this general permit.

Section C. Limitations on Permit Coverage

1. Post Construction Discharges

Discharges that occur after construction activities have been completed, and after the construction site and any supporting activity site have undergone final stabilization, are not eligible for coverage under this general permit. Discharges originating from the sites are not authorized under this general permit following the submission of the Notice of Termination (NOT) or removal of the appropriate TCEQ site notice, as applicable, for the regulated construction activity.

2. Prohibition of Non-Stormwater Discharges

Except as otherwise provided in Part II.A. of this general permit, only discharges that are composed entirely of stormwater associated with construction activity may be authorized under this general permit.

3. Compliance with Water Quality Standards

Discharges to surface water in the state that would cause, have the reasonable potential to cause, or contribute to a violation of water quality standards or that would fail to protect and maintain existing designated uses of surface water in the state are not eligible for coverage under this general permit. The executive director may require an application for an individual permit or alternative general permit (see Parts II.H.2. and 3.) to authorize discharges to surface water in the state if the executive director determines that any activity will cause, has the reasonable potential to cause, or contribute to a violation of water quality standards or is found to cause, has the reasonable potential to cause, or contribute to, the impairment of a designated use. The executive director may also require an application for an individual permit considering factors described in Part II.H.3. of this general permit.

4. Impaired Receiving Waters and Total Maximum Daily Load (TMDL) Requirements

The permittee shall determine whether the authorized discharge is to an impaired water body on the latest EPA-approved CWA § 303(d) List or waters with an EPA-approved or established TMDL that are found on the latest EPA-approved *Texas Integrated Report of Surface Water Quality for CWA Sections 305(b) and 303(d)*, which lists the category 4 and 5 water bodies.

New sources or new discharges of the pollutants of concern to impaired waters are not authorized by this permit unless otherwise allowable under 30 TAC Chapter 305 and applicable state law. Impaired waters are those that do not meet applicable water quality standard(s) and are listed as category 4 or 5 in the current version of the *Texas Integrated Report of Surface Water Quality for CWA Sections 305(b) and 303(d)*, and waterbodies listed on the CWA § 303(d) List. Pollutants of concern are those for which the water body is listed as impaired.

Discharges of the pollutants of concern to impaired water bodies for which there is a TMDL are not eligible for coverage under this general permit unless they are consistent with the approved TMDL. Permittees must incorporate the conditions and requirements applicable to their discharges into their SWP3, in order to be eligible for coverage under this general permit. For consistency with the construction stormwater-related items in an approved TMDL, the SWP3 must be consistent with any applicable condition, goal, or requirement in the TMDL, TMDL Implementation Plan (I-Plan), or as otherwise directed by the executive director.

5. Discharges to the Edwards Aquifer Recharge or Contributing Zone

Discharges cannot be authorized by this general permit where prohibited by 30 TAC Chapter 213 (relating to Edwards Aquifer). In addition, commencement of construction (see definition for commencement of construction in Part I.B. above) at a site regulated under 30 TAC Chapter 213, may not begin until the appropriate Edwards Aquifer Protection Plan (EAPP) has been approved by the TCEQ's Edwards Aquifer Protection Program.

- (a) For new discharges located within the Edwards Aquifer Recharge Zone, or within that area upstream from the recharge zone and defined as the Contributing Zone (CZ), operators must meet all applicable requirements of, and operate according to, 30 TAC Chapter 213 (Edwards Aquifer Rule) in addition to the provisions and requirements of this general permit.

- (b) For existing discharges located within the Edwards Aquifer Recharge Zone, the requirements of the agency-approved Water Pollution Abatement Plan (WPAP) under the Edwards Aquifer Rule are in addition to the requirements of this general permit. BMPs and maintenance schedules for structural stormwater controls, for example, may be required as a provision of the rule. All applicable requirements of the Edwards Aquifer Rule for reductions of suspended solids in stormwater runoff are in addition to the requirements in this general permit for this pollutant.
- (c) For discharges located within ten (10) stream miles upstream of the Edwards Aquifer recharge zone, applicants shall also submit a copy of the NOI to the appropriate TCEQ regional office.

Counties: Comal, Bexar, Medina, Uvalde, and Kinney

Contact: TCEQ Water Program Manager
San Antonio Regional Office
14250 Judson Road
San Antonio, Texas 78233-4480
(210) 490-3096

Counties: Williamson, Travis, and Hays

Contact: TCEQ Water Program Manager
Austin Regional Office
12100 Park 35 Circle
Room 179, Building A
Austin, Texas 78753
(512) 339-2929

6. Discharges to Specific Watersheds and Water Quality Areas

Discharges otherwise eligible for coverage cannot be authorized by this general permit where prohibited by 30 TAC Chapter 311 (relating to Watershed Protection) for water quality areas and watersheds.

7. Protection of Streams and Watersheds by Other Governmental Entities

This general permit does not limit the authority or ability of federal, other state, or local governmental entities from placing additional or more stringent requirements on construction activities or discharges from construction activities.

8. Indian Country Lands

Stormwater runoff from construction activities occurring on Indian Country lands are not under the authority of the TCEQ and are not eligible for coverage under this general permit. If discharges of stormwater require authorization under federal NPDES regulations, authority for these discharges must be obtained from the U.S. Environmental Protection Agency (EPA).

9. Exempt Oil and Gas Activities

The CWA § 402(l)(2) provides that stormwater discharges from construction activities related to oil and gas exploration, production, processing, or treatment, or transmission facilities are exempt from regulation under this permit. The term “oil and gas exploration, production, processing, or treatment operations, or transmission facilities” is defined in 33 U.S.C. Annotated § 1362 (24).

The exemption in CWA § 402(l)(2) *includes* stormwater discharges from construction activities regardless of the amount of disturbed acreage, which are necessary to prepare a site for drilling and the movement and placement of drilling equipment, drilling waste management pits, in field treatment plants, and in field transportation infrastructure (e.g., crude oil pipelines, natural gas treatment plants, and both natural gas transmission pipeline compressor and crude oil pumping stations) necessary for the operation of most producing oil and gas fields. Construction activities are defined in 33 U.S. Code § 1362(24) and interpreted by EPA in the final rule. *See* June 12, 2006 Amendments to the NPDES Regulations for Storm Water Discharges Associated with Oil and Gas Exploration, Production, Processing, or Treatment Operations or Transmission Facilities (71 FR 33628, Part V. Terminology).

The exemption *does not include* stormwater discharges from the construction of administrative buildings, parking lots, and roads servicing an administrative building at an oil and gas site, as these are considered traditional construction activities.

As described in 40 CFR § 122.26(c)(1)(iii) [*regulations prior to 2006*], discharges from oil and gas construction activities are waived from CWA § 402(l)(2) permit coverage *unless* the construction activity (or construction support activity) has had a discharge of stormwater resulting in the discharge of a reportable quantity of oil or hazardous substances or the discharge contributes to a violation of water quality standards.

Exempt oil and gas activities which have lost their exemption as a result of one of the above discharges, must obtain permit coverage under this general permit, an alternative general permit, or a TPDES individual permit prior to the next discharge.

10. Stormwater Discharges from Agricultural Activities

Stormwater discharges from agricultural activities that are not point source discharges of stormwater are not subject to TPDES permit requirements. These activities may include clearing and cultivating ground for crops, construction of fences to contain livestock, construction of stock ponds, and other similar agricultural activities. Discharges of stormwater runoff associated with the construction of facilities that are subject to TPDES regulations, such as the construction of concentrated animal feeding operations, would be point sources regulated under this general permit.

11. Endangered Species Act

Discharges that would adversely affect a listed endangered or threatened aquatic or aquatic-dependent species or its critical habitat are not authorized by this permit, unless the requirements of the Endangered Species Act are satisfied. Federal requirements related to endangered species apply to all TPDES permitted discharges and site-specific controls may be required to ensure that protection of endangered or threatened species is achieved. If a permittee has concerns over potential impacts to listed species, the permittee may contact TCEQ for additional information.

12. Storage of High-Level Radioactive Waste

Discharges of stormwater from construction activities associated with the construction of a facility that is licensed for the storage of high-level radioactive waste by the United States Nuclear Regulatory Commission under 10 CFR Part 72 are not authorized by this general permit. Texas Health and Safety Code (THSC) § 401.0525 prohibits TCEQ from issuing any TPDES authorizations for the construction or operation of these facilities.

Discharges of stormwater from the construction activities associated with the construction of a facility located at the site of currently or formerly operating nuclear power reactors and currently or formerly operating nuclear research and test reactors operated by a university are not prohibited under THSC § 401.0525 and continue to be regulated under this general permit.

13. Other

Nothing in Part II. of the general permit is intended to negate any person's ability to assert *force majeure* (act of God, war, strike, riot, or other catastrophe) defenses found in 30 TAC § 70.7

Section D. Deadlines for Obtaining Authorization to Discharge

1. Large Construction Activities

- (a) New Construction – Discharges from sites where the commencement of construction activity occurs on or after the effective date of this general permit must be authorized, either under this general permit or a separate TPDES permit, prior to the commencement of those construction activities.
- (b) Ongoing Construction – Operators of large construction activities continuing to operate after the effective date of this permit, and authorized under the TPDES Construction General Permit (CGP) TXR150000 (effective on March 5, 2018, and amended on January 28, 2022), must submit an NOI to renew authorization or an NOT to terminate coverage under this general permit within 90 days of the effective date of this general permit. During this interim or grace period, as a requirement of this TPDES permit, the operator must continue to meet the conditions and requirements of the issued and amended 2018 TPDES CGP.

2. Small Construction Activities

- (a) New Construction – Discharges from sites where the commencement of construction activity occurs on or after the effective date of this general permit must be authorized, either under this general permit or a separate TPDES permit, prior to the commencement of those construction activities.
- (b) Ongoing Construction – Discharges from ongoing small construction activities that commenced prior to the effective date of this general permit, and that do not meet the conditions to qualify for termination of this permit as described in Part II.F. of this general permit, must meet the requirements to be authorized, either under this general permit or a separate TPDES permit, within 90 days of the effective date of this general permit. During this interim period, as a requirement of this TPDES permit, the operator must continue to meet the conditions and requirements of the issued and amended 2018 TPDES CGP.

Section E. Obtaining Authorization to Discharge

1. Automatic Authorization for Small Construction Activities with Low Potential for Erosion

Operators of small construction activity, as defined in Part I.B. of this general permit, shall not submit an NOI for coverage, unless otherwise required by the executive director.

Operators of small construction activities, which occur in certain counties and during periods of low potential for erosion that do not meet the conditions of the waiver described in Part II.G. of this general permit, may be automatically authorized under this general permit if all the following conditions are met prior to the commencement of construction.

- (a) The construction activity occurs in a county and during the corresponding date range(s) listed in Appendix A;

- (b) The construction activity is initiated and completed, including either final or temporary stabilization of all disturbed areas, within the time frame identified in Appendix A for the location of the construction site;
- (c) All temporary stabilization is adequately maintained to effectively reduce or prohibit erosion, permanent stabilization activities have been initiated, and a condition of final stabilization is completed no later than 30 days following the end date of the time frame identified in Appendix A for the location of the construction site; the permittee signs a completed TCEQ Small Construction Site Notice for low potential for erosion (Form TCEQ-20964), including the certification statement;
- (d) A signed and certified copy of the TCEQ Small Construction Site Notice for low potential for erosion is posted at the construction site in a location where it is readily available for viewing by the general public, local, state, and federal authorities prior to commencing construction activities, and maintained in that location until final stabilization has been achieved;

NOTE: Posted TCEQ site notices may have a redacted signature as long as there is an original signed and certified TCEQ site notice, with a viewable signature, located on-site and available for review by any applicable regulatory authority.

- (e) A copy of the signed and certified TCEQ Small Construction Site Notice for low potential for erosion is provided to the operator of any MS4 receiving the discharge at least two (2) days prior to commencement of construction activities;
- (f) Discharges of stormwater runoff or other non-stormwater discharges from any supporting concrete batch plant or asphalt batch plant is separately authorized under an individual TPDES permit, another TPDES general permit, or under an individual TCEQ permit where stormwater and non-stormwater is disposed of by evaporation or irrigation (discharges are adjacent to water in the state); and
- (g) Any non-stormwater discharges are either authorized under a separate permit or authorization, are not considered by TCEQ to be a wastewater, or are captured and routed for disposal at a publicly operated treatment works or licensed waste disposal facility.

If all of the conditions in (a) – (h) above are met, then the operator(s) of small construction activities with low potential for erosion are not required to develop a SWP3.

If an operator is conducting small construction activities and any of the above conditions (a) – (h) are not met, the operator cannot declare coverage under the automatic authorization for small construction activities with low potential for erosion and must meet the requirements for automatic authorization (all other) small construction activities, described below in Part II.E.2.

For small construction activities that occur during a period with a low potential for erosion, where automatic authorization under this section is not available, an operator may apply for and obtain a waiver from permitting (Low Rainfall Erosivity Waiver – LREW), as described in Part II.G. of this general permit. Waivers from coverage under the LREW do not allow for any discharges of non-stormwater and the operator must ensure that discharges on non-stormwater are either authorized under a separate permit or authorization.

2. Automatic Authorization for Small Construction Activities

Operators of small construction activities as defined in Part I.B. of this general permit shall not submit an NOI for coverage, unless otherwise required by the executive director.

Operators of small construction activities, as defined in Part I.B. of this general permit or as defined but who do not meet in the conditions and requirements located in Part II.E.1 above, may be automatically authorized for small construction activities, provided that they meet all of the following conditions:

- (a) develop a SWP3 according to the provisions of this general permit, that covers either the entire site or all portions of the site for which the applicant is the operator, and implement the SWP3 prior to commencing construction activities;
- (b) all operators of regulated small construction activities must post a copy of a signed and certified TCEQ Small Construction Site Notice (Form TCEQ-20963), the notice must be posted at the construction site in a location where it is safely and readily available for viewing by the general public, local, state, and federal authorities, at least two (2) days prior to commencing construction activity, and maintain the notice in that location until completion of the construction activity (for linear construction activities, e.g. pipeline or highway, the TCEQ site notice must be placed in a publicly accessible location near where construction is actively underway; notice for these linear sites may be relocated, as necessary, along the length of the project, and the notice must be safely and readily available for viewing by the general public; local, state, and federal authorities);
- (c) operators must maintain a posted TCEQ Small Construction Site Notice on the approved TCEQ form at the construction site until final stabilization has been achieved; and

NOTE: Posted TCEQ site notices may have a redacted signature as long as there is an original signed and certified TCEQ Small Construction Site Notice, with a viewable signature, located on-site and available for review by an applicable regulatory authority.

- (d) provide a copy of the signed and certified TCEQ Small Construction Site Notice to the operator of any municipal separate storm sewer system (MS4) receiving the discharge at least two (2) days prior to commencement of construction activities.
- (e) if signatory authority is delegated by an authorized representative, then a Delegation of Signatory form must be submitted as required by 30 TAC § 305.128 (relating to Signatories to Reports). Operators for small construction activities must submit this form via mail following the instructions on the approved TCEQ paper form. A new Delegation of Signatory form must be submitted if the delegation changes to another individual or position.

As described in Part I.B of this general permit, large construction activities include those that will disturb less than five (5) acres of land, but that are part of a larger common plan of development or sale that will ultimately disturb five (5) or more acres of land and must meet the requirements of Part II.E.3. below.

3. Authorization for Large Construction Activities

Operators of large construction activities that qualify for coverage under this general permit must meet all of the following conditions:

- (a) develop a SWP3 according to the provisions of this general permit that covers either the entire site or all portions of the site where the applicant is the operator. The SWP3 must be developed and implemented prior to obtaining coverage and prior to commencing construction activities;
- (b) primary operators of large construction activities must submit an NOI prior to commencing construction activity at a construction site. A completed NOI must be submitted to TCEQ electronically using the online ePermits system on TCEQ's website.

Operators with an electronic reporting waiver must submit a completed paper NOI to TCEQ at least seven (7) days prior to commencing construction activity to obtain provisional coverage 48-hours from the postmark date for delivery to the TCEQ. An authorization is no longer provisional when the executive director finds the NOI is administratively complete, and an authorization number is issued to the permittee for the construction site indicated on the NOI.

If an additional primary operator is added after the initial NOI is submitted, the additional primary operator must meet the same requirements for existing primary operator(s), as indicated above.

If the primary operator changes due to responsibility at the site being transferred from one primary operator to another after the initial NOI is submitted, the new primary operator must submit an electronic NOI, unless they request and obtain a waiver from electronic reporting, at least ten (10) days prior to assuming operational control of a construction site and commencing construction activity.

- (c) all operators of large construction activities must post a TCEQ Large Construction Site Notice on the approved TCEQ form (Form TCEQ-20961) in accordance with Part III.D.2. of this permit. The TCEQ site notice must be located where it is safely and readily available for viewing by the general public, local, state, and federal authorities prior to commencing construction activities, and must be maintained in that location until final stabilization has been achieved. For linear construction activities, e.g., pipeline or highway, the TCEQ site notice must be placed in a publicly accessible location near where construction is actively underway; notice for these linear sites may be relocated, as necessary, along the length of the project, and the notice must be safely and readily available for viewing by the general public, local, state, and federal authorities;
- (d) two days prior to commencing construction activities, all primary operators must:
 - i. provide a copy of the signed NOI to the operator of any MS4 receiving the discharge and to any secondary construction operator, and
 - ii. list in the SWP3 the names and addresses of all MS4 operators receiving a copy;
- (e) if signatory authority is delegated by an authorized representative, then a Delegation of Signatories form must be submitted as required by 30 TAC § 305.128 (relating to Signatories to Reports). Primary operators must submit this form electronically using the State of Texas Environmental Electronic Reporting System (STEERS), TCEQ's online permitting system, or by paper if the permittee requested and obtained an electronic reporting waiver. A new Delegation of Signatories form must be submitted, if the delegation changes to another individual or position;
- (f) all persons meeting the definition of "secondary operator" in Part I of this permit are hereby notified that they are regulated under this general permit, but are not required to submit an NOI, provided that a primary operator at the site has submitted an NOI, or prior to commencement of construction activities, a primary operator is required to submit an NOI and the secondary operator has provided notification to the operator(s) of the need to obtain coverage (with records of notification available upon request). Any secondary operator notified under this provision may alternatively submit an NOI under this general permit, may seek coverage under an alternative TPDES individual permit, or may seek coverage under an alternative TPDES general permit if available; and

- (g) all secondary operators of large construction activities must post a copy of the signed and certified TCEQ Large Construction Site Notice for Secondary Operators on the approved TCEQ form (Form TCEQ-20962) and provide a copy of the signed and certified TCEQ site notice to the operator of any MS4 receiving the discharge at least two (2) days prior to the commencement construction activities.

NOTE: Posted TCEQ site notices may have a redacted signature as long as there is an original signed and certified TCEQ Large Construction Site Notice for Secondary Operators, with a viewable signature, located on-site and available for review by an applicable regulatory authority.

Applicants must submit an NOI using the online ePermits system (accessed using STEERS) available through the TCEQ website, or request and obtain a waiver from electronic reporting from the TCEQ. Waivers from electronic reporting are not transferrable and expire on the same date as the authorization to discharge.

4. Waivers for Small Construction Activities:

Operators of certain small construction activities may obtain a waiver from coverage under this general permit, if applicable. The requirements are outlined in Part II.G. below.

5. Effective Date of Coverage

- (a) Operators of small construction activities as described in either Part II.E.1. or II.E.2. above are authorized immediately following compliance with the applicable conditions of Part II.E.1. or II.E.2. Secondary operators of large construction activities as described in Part II.E.3. above are authorized immediately following compliance with the applicable conditions in Part II.E.3. For activities located in areas regulated by 30 TAC Chapter 213, related to the Edwards Aquifer, this authorization to discharge is separate from the requirements of the operator's responsibilities under that rule. Construction may not commence for sites regulated under 30 TAC Chapter 213 until all applicable requirements of that rule are met.
- (b) Primary operators of large construction activities as described in Part II.E.3. above that electronically submit an NOI are authorized immediately following confirmation of receipt of the electronic form by the TCEQ, unless otherwise notified by the executive director.

Operators with an electronic reporting waiver are provisionally authorized 48-hours from the date that a completed paper NOI is postmarked for delivery to the TCEQ, unless otherwise notified by the executive director. An authorization is no longer provisional when the executive director finds the NOI is administratively complete and an authorization number is issued to the permittee for the construction site indicated on the NOI.

For construction activities located in areas regulated by 30 TAC Chapter 213, related to the Edwards Aquifer, this authorization to discharge is separate from the requirements of the operator's responsibilities under that rule. Construction activities may not commence for sites regulated under 30 TAC Chapter 213 until all applicable requirements of that rule are met.

- (c) Operators are not prohibited from submitting late NOIs or posting late site notices to obtain authorization under this general permit. The TCEQ reserves the right to take appropriate enforcement action for any unpermitted activities that may have occurred between the time construction commenced and authorization under this general permit was obtained.

- (d) If operators that submitted NOIs have active authorizations for construction activities that are ongoing when this general permit expires on March 5, 2028, and a new general permit is issued, a 90-day interim (grace) period is granted to provide coverage that is administratively continued until operators with active authorizations can obtain coverage under the newly issued CGP. The 90-day grace period starts on the effective date of the newly issued CGP.

6. Contents of the NOI

The NOI form shall require, at a minimum, the following information:

- (a) the TPDES CGP authorization number for existing authorizations under this general permit, where the operator submits an NOI to renew coverage within 90 days of the effective date of this general permit;
- (b) the name, address, and telephone number of the operator filing the NOI for permit coverage;
- (c) the name (or other identifier), address, county, and latitude/longitude of the construction project or site;
- (d) the number of acres that will be disturbed by the applicant;
- (e) the estimated construction project start date and end date;
- (f) confirmation that the project or site will not be located on Indian Country lands;
- (g) confirmation if the construction activity is associated with an oil and gas exploration, production, processing, or treatment, or transmission facility (see Part II.C.9.)
- (h) confirmation that the construction activities are not associated with the construction of a facility that is licensed for the storage of high-level radioactive waste by the United States Nuclear Regulatory Commission under 10 CFR Part 72 (see Part II.C.12.);
- (i) confirmation that a SWP3 has been developed in accordance with all conditions of this general permit, that it will be implemented prior to commencement of construction activities, and that it is compliant with any applicable local sediment and erosion control plans; for multiple operators who prepare a shared SWP3, the confirmation for an operator may be limited to its obligations under the SWP3 provided all obligations are confirmed by at least one operator;
- (j) name of the receiving water(s);
- (k) the classified segment number for each classified segment that receives discharges from the regulated construction activity (if the discharge is not directly to a classified segment, then the classified segment number of the first classified segment that those discharges reach); and
- (l) the name of all surface waters receiving discharges from the regulated construction activity that are on the latest EPA-approved CWA § 303(d) List of impaired waters or *Texas Integrated Report of Surface Water Quality for CWA Sections 305(b) and 303(d)* as not meeting applicable state water quality standards.

7. Notice of Change (NOC)

- (a) If relevant information provided in the NOI changes, the operator that has submitted the NOI must submit an NOC to TCEQ at least fourteen (14) days before the change occurs. Where a 14-day advance notice is not possible, the operator must submit an NOC to TCEQ within fourteen (14) days of discovery of the change. If the operator becomes aware that it failed to submit any relevant facts or submitted

incorrect information in an NOI, the correct information must be submitted to TCEQ in an NOC within fourteen (14) days after discovery.

- (b) Information on an NOC may include, but is not limited to, the following:
- i. a change in the description of the construction project;
 - ii. an increase in the number of acres disturbed (for increases of one (1) or more acres);
 - iii. or the name of the operator (where the name of the operator has changed).
- (c) Electronic NOC.

Applicants must submit an NOC using the online ePermits system available through the TCEQ website, or request and obtain a waiver from electronic reporting from the TCEQ. All waivers from electronic reporting are not transferrable. Electronic reporting waivers expire on the same date as the authorization to discharge, except for temporary waivers that expire one (1) year from issuance. A copy of the NOC form or letter must also be placed in the SWP3 and provided to the operator of any MS4 receiving the discharge. Operators are authorized immediately following confirmation of receipt of the electronic form by the TCEQ, unless otherwise notified by the executive director.

- (d) Paper NOC.

Applicants who request and obtain an electronic reporting waiver shall submit the NOC on a paper form provided by the executive director, or by letter if an NOC form is not available.

- (e) A copy of the NOC form or letter must also be placed in the SWP3 and provided to the operator of any MS4 receiving the discharge. A list that includes the names and addresses of all MS4 operators receiving a copy of the NOC (or NOC letter) must be included in the SWP3. Information that may not be included on an NOC includes but is not limited to the following:
- i. transfer of operational control from one operator to another, including a transfer of the ownership of a company. A transfer of ownership of a company includes changes to the structure of a company, such as changing from a partnership to a corporation or changing corporation types, so that the filing or charter number that is on record with the Texas Secretary of State (SOS) must be changed.
 - ii. coverage under this general permit is not transferable from one operator to another. Instead, the new operator will need to submit an NOI or LREW, as applicable, and the previous operator will need to submit an NOT.
 - iii. a decrease in the number of acres disturbed. This information must be included in the SWP3 and retained on site.

8. Signatory Requirement for NOI Forms, NOT Forms, NOC Forms, and Construction Site Notices

NOI forms, NOT forms, NOC forms, and Construction Site Notices that require a signature must be signed according to 30 TAC § 305.44 (relating to Signatories for Applications).

Section F. Terminating Coverage

1. Notice of Termination (NOT) Required

Each operator that has submitted an NOI for authorization of large construction activities under this general permit must apply to terminate that authorization following the conditions described in this section of the general permit.

Authorization of large construction must be terminated by submitting an NOT electronically via the online ePermits system available through the TCEQ website, or on a paper NOT form to TCEQ supplied by the executive director with an approved waiver from electronic reporting. Authorization to discharge under this general permit terminates at midnight on the day a paper NOT is postmarked for delivery to the TCEQ or immediately following confirmation of the receipt of the NOT submitted electronically by the TCEQ.

Applicants must submit an NOT using the online ePermits system available through the TCEQ website, or request and obtain a waiver from electronic reporting from the TCEQ. Waivers from electronic reporting are not transferrable and expire on the same date as the authorization to discharge, except for temporary waivers that expire one (1) year from issuance.

The NOT must be submitted to TCEQ, and a copy of the NOT provided to the operator of any MS4 receiving the discharge (with a list in the SWP3 of the names and addresses of all MS4 operators receiving a copy), within 30 days after any of the following conditions are met:

- (a) final stabilization has been achieved on all portions of the site that are the responsibility of the operator;
- (b) a transfer of operational control has occurred (See Section II.F.4. below); or
- (c) the operator has obtained alternative authorization under an individual TPDES permit or alternative TPDES general permit.

Compliance with the conditions and requirements of this permit is required until the NOT is submitted and approved by TCEQ.

2. Minimum Contents of the NOT

The NOT form shall require, at a minimum, the following information:

- (a) if authorization for construction activity was granted following submission of an NOI, the permittee's site-specific TPDES authorization number for a specific construction site;
- (b) an indication of whether final stabilization has been achieved at the site and a NOT has been submitted or if the permittee is simply no longer an operator at the site;
- (c) the name, address, and telephone number of the permittee submitting the NOT;
- (d) the name (or other identifier), address, county, and location (latitude/longitude) of the construction project or site; and
- (e) a signed certification that either all stormwater discharges requiring authorization under this general permit will no longer occur, or that the applicant is no longer the operator of the facility or construction site, and that all temporary structural erosion controls have either been removed, will be removed on a schedule defined in the SWP3, or have been transferred to a new operator if the new operator has applied for permit coverage. Erosion controls that are designed to remain in place for an indefinite period, such as mulches and fiber mats, are not required to be removed or scheduled for removal.

3. Termination of Coverage for Small Construction Sites and for Secondary Operators at Large Construction Sites
- (a) Each operator that has obtained automatic authorization for small construction or is a secondary operator for large construction must perform the following when terminating coverage under the permit:
- i. remove the TCEQ site notice;
 - ii. complete the applicable portion of the TCEQ site notice related to removal of the TCEQ site notice; and
 - iii. submit a copy of the completed TCEQ site notice to the operator of any MS4 receiving the discharge (or provide alternative notification as allowed by the MS4 operator, with documentation of such notification included in the SWP3).
- (b) The activities described in Part II.F.3.(a) above must be completed by the operator within 30 days of meeting any of the following conditions:
- i. final stabilization has been achieved on all portions of the site that are the responsibility of the operator;
 - ii. a transfer of day-to-day operational control over activities necessary to ensure compliance with the SWP3 and other permit conditions has occurred (See Section II.F.4. below); or
 - iii. the operator has obtained alternative authorization under an individual or general TPDES permit.

For Small Construction Sites and Secondary Operators at Large Construction Sites, authorization to discharge under this general permit terminates immediately upon removal of the applicable TCEQ construction site notice. Compliance with the conditions and requirements of this permit is required until the TCEQ construction site notice is removed. The construction site notice cannot be removed until final stabilization has been achieved.

4. Transfer of Day-to-Day Operational Control
- (a) When the primary operator of a large construction activity changes or operational control over activities necessary to ensure compliance with the SWP3 and other permit conditions is transferred to another primary operator, the original operator must do the following:
- i. submit an NOT within ten (10) days prior to the date that responsibility for operations terminates, and the new operator must submit an NOI at least ten (10) days prior to the transfer of operational control, in accordance with condition (c) below; and
 - ii. submit a copy of the NOT from the primary operator terminating its coverage under the permit and its operational control of the construction site and submit a copy of the NOI from the new primary operator to the operator of any MS4 receiving the discharge in accordance with Part II.F.1. above.
- (b) For transfer of operational control, operators of small construction activities and secondary operators of large construction activities who are not required to submit an NOI must do the following:
- i. the existing operator must remove the original TCEQ construction site notice, and the new operator must post the required TCEQ construction site notice prior to the transfer of operational control, in accordance with the conditions in Part II.F.4.(c) i or ii below; and

- ii. a copy of the TCEQ construction site notice, which must be completed and provided to the operator of any MS4 receiving the discharge, in accordance with Part II.F.3. above.
- (c) Each operator is responsible for determining its role as an operator as defined in Part I.B. and obtaining authorization under the permit, as described above in Part II.E. 1. - 3. Where authorization has been obtained by submitting an NOI for coverage under this general permit, permit coverage is not transferable from one operator to another. A transfer of operational control can include changes to the structure of a company, such as changing from a partnership to a corporation, or changing to a different corporation type such that a different filing (or charter) number is established with the Texas Secretary of State (SOS). A transfer of operational control can also occur when one of the following criteria is met, as applicable:
- i. another operator has assumed control over all areas of the site that do not meet the definition for final stabilization;
 - ii. all silt fences and other temporary erosion controls have either been removed, scheduled for removal as defined in the SWP3, or transferred to a new operator, provided that the original permitted operator has attempted to notify the new operator in writing of the requirement to obtain permit coverage. Records of this notification (or attempt at notification) shall be retained by the operator transferring operational control to another operator in accordance with Part VI of this permit. Erosion controls that are designed to remain in place for an indefinite period, such as mulches and fiber mats, are not required to be removed or scheduled for removal; or
 - iii. a homebuilder has purchased one (1) or more lots from an operator who obtained coverage under this general permit for a common plan of development or sale. The homebuilder is considered a new operator and shall comply with the requirements of this permit. Under these circumstances, the homebuilder is only responsible for compliance with the general permit requirements as they apply to the lot(s) it has operational control over in a larger common plan of development, and the original operator remains responsible for common controls or discharges, and must amend its SWP3 to remove the lot(s) transferred to the homebuilder.

Section G. Waivers from Coverage

The executive director may waive the otherwise applicable requirements of this general permit for stormwater discharges from small construction activities under the terms and conditions described in this section.

1. Waiver Applicability and Coverage

Operators of small construction activities may apply for and receive a waiver from the requirements to obtain authorization under this general permit, when the calculated rainfall erosivity (R) factor for the entire period of the construction project is less than five (5).

The operator must submit a Low Rainfall Erosivity Waiver (LREW) certification form to the TCEQ electronically via the online ePermits system available through the TCEQ website. The LREW form is a certification by the operator that the small construction activity will commence and be completed within a period when the value of the calculated R factor is less than five (5).

Applicants who request and obtain an electronic reporting waiver shall submit the LREW on a paper form provided by the executive director at least seven (7) days prior to commencing construction activity to obtain provisional coverage 48-hours from the postmark date for delivery to the TCEQ. An authorization is no longer provisional when the executive director finds the LREW is administratively complete, and an authorization number is issued to the permittee for the construction site indicated on the LREW. Waivers from electronic reporting are not transferrable and expire on the same date as the authorization to discharge, except for temporary waivers that expire one (1) year from issuance.

This LREW from coverage does not apply to any non-stormwater discharges, including what is allowed under this permit. The operator must ensure that all non-stormwater discharges are either authorized under a separate permit or authorization or are captured and routed to an authorized treatment facility for disposal.

2. Steps to Obtaining a Waiver

The construction site operator may calculate the R factor to request a waiver using the following steps:

- (a) estimate the construction start date and the construction end date. The construction end date is the date that final stabilization will be achieved.
- (b) find the appropriate Erosivity Index (EI) zone in Appendix B of this permit.
- (c) find the EI percentage for the project period by adding the results for each period of the project using the table provided in Appendix D of this permit, in EPA Fact Sheet 2.1, or in USDA Handbook 703, by subtracting the start value from the end value to find the percent EI for the site.
- (d) refer to the Isoerodent Map (Appendix C of this permit) and interpolate the annual isoerodent value for the proposed construction location.
- (e) multiply the percent value obtained in Step (c) above by the annual isoerodent value obtained in Step (d). This is the R factor for the proposed project. If the value is less than five (5), then a waiver may be obtained. If the value is five (5) or more, then a waiver may not be obtained, and the operator must obtain coverage under Part II.E.2. of this permit.

Alternatively, the operator may calculate a site-specific R factor utilizing the following online calculator: <https://lew.epa.gov/>, or using another available resource.

A copy of the LREW certification form is not required to be posted at the small construction site.

3. Effective Date of an LREW

Unless otherwise notified by the executive director, operators of small construction activities seeking coverage under an LREW are provisionally waived from the otherwise applicable requirements of this general permit 48-hours from the date that a completed paper LREW certification form is postmarked for delivery to TCEQ, or immediately upon receiving confirmation of approval of an electronic submittal, made via the online ePermits system available through the TCEQ website.

Applicants seeking coverage under an LREW must submit an application for an LREW using the online ePermits system available through the TCEQ website, or request and obtain a waiver from electronic reporting from the TCEQ. Waivers from electronic reporting are not transferrable and expire on the same date as the authorization to discharge.

4. Activities Extending Beyond the LREW Period

If a construction activity extends beyond the approved waiver period due to circumstances beyond the control of the operator, the operator must either:

- (a) recalculate the R factor using the original start date and a new projected ending date, and if the R factor is still under five (5), submit a new LREW form at least two (2) days before the end of the original waiver period; or
- (b) obtain authorization under this general permit according to the requirements for automatic authorization for small construction activities in Part II.E.2. of this permit, prior to the end of the approved LREW period.

Section H. Alternative TPDES Permit Coverage

1. Individual Permit Alternative

Any discharge eligible for coverage under this general permit may alternatively be authorized under an individual TPDES permit according to 30 TAC Chapter 305 (relating to Consolidated Permits). Applications for individual permit coverage must be submitted at least 330 days prior to commencement of construction activities to ensure timely authorization. Existing coverage under this general permit should not be terminated until an individual permit is issued and in effect.

2. General Permit Alternative

Any discharges eligible for authorization under this general permit may alternatively be authorized under a separate general permit according to 30 TAC Chapter 205 (relating to General Permits for Waste Discharges), as applicable.

3. Individual Permit Required

The executive director may require an operator of a construction site, otherwise eligible for authorization under this general permit, to apply for an individual TPDES permit in the following circumstances:

- (a) the conditions of an approved TMDL or TMDL I-Plan on the receiving water;
- (b) the activity being determined to cause, has a reasonable potential to cause, or contribute to a violation of water quality standards or being found to cause, or contribute to, the loss of a designated use of surface water in the state; and
- (c) any other consideration defined in 30 TAC Chapter 205 (relating to General Permits for Waste Discharges) including 30 TAC § 205.4(c)(3)(D), which allows the commission to deny authorization under the general permit and require an individual permit if a discharger has been determined by the executive director to have been out of compliance with any rule, order, or permit of the commission, including non-payment of fees assessed by the executive director.

A discharger with a TCEQ compliance history rating of “unsatisfactory” is ineligible for coverage under this general permit. In that case, 30 TAC § 60.3 requires the executive director to deny or suspend an authorization to discharge under a general permit. However, per TWC § 26.040(h), a discharger is entitled to a hearing before the commission prior to having an authorization denied or suspended for having an “unsatisfactory” compliance history.

Denial of authorization to discharge under this general permit or suspension of a permittee’s authorization under this general permit for reasons other than compliance history shall be done according to commission rules in 30 TAC Chapter 205 (relating to General Permits for Waste Discharges).

Section I. Permit Expiration

1. This general permit is effective for a term not to exceed five (5) years. All active discharge authorizations expire on the date provided on page one (1) of this permit. Following public notice and comment, as provided by 30 TAC § 205.3 (relating to Public Notice, Public Meetings, and Public Comment), the commission may amend, revoke, cancel, or renew this general permit. All authorizations that are active at the time the permit term expires will be administratively continued as indicated in Part II.I.2. below and in Part II.D.1.(b) and D.2.(b) of this permit.
2. If the executive director publishes a notice of the intent to renew or amend this general permit before the expiration date, the permit will remain in effect for existing, authorized discharges until the commission takes final action on the permit. Upon issuance of a renewed or amended permit, permittees may be required to submit an NOI within 90 days following the effective date of the renewed or amended permit, unless that permit provides for an alternative method for obtaining authorization.
3. If the commission does not propose to reissue this general permit within 90 days before the expiration date, permittees shall apply for authorization under an individual permit or an alternative general permit. If the application for an individual permit is submitted before the expiration date, authorization under this expiring general permit remains in effect until the issuance or denial of an individual permit. No new NOIs will be accepted nor new authorizations honored under the general permit after the expiration date.

Part III. Stormwater Pollution Prevention Plans (SWP3)

All regulated construction site operators shall prepare an SWP3, prior to submittal of an NOI, to address discharges authorized under Parts II.E.2. and II.E.3. of this general permit that will reach waters of the U.S. This includes discharges to MS4s and privately owned separate storm sewer systems that drain into surface water in the state or waters of the U.S.

Individual operators at a site may develop separate SWP3s that cover only their portion of the project, provided reference is made to the other operators at the site. Where there is more than one (1) SWP3 for a site, operators must coordinate to ensure that BMPs and controls are consistent and do not negate or impair the effectiveness of each other. Regardless of whether a single comprehensive SWP3 is developed or separate SWP3s are developed for each operator, it is the responsibility of each operator to ensure compliance with the terms and conditions of this general permit in the areas of the construction site where that operator has control over construction plans and specifications or day-to-day operations.

An SWP3 must describe the implementation of practices that will be used to minimize to the extent practicable the discharge of pollutants in stormwater associated with construction activity and non-stormwater discharges described in Part II.A.3., in compliance with the terms and conditions of this permit.

An SWP3 must also identify any potential sources of pollution that have been determined to cause, have a reasonable potential to cause, or contribute to a violation of water quality standards or have been found to cause or contribute to the loss of a designated use of surface water in the state from discharges of stormwater from construction activities and construction support activities. Where potential sources of these pollutants are present at a construction site, the SWP3 must also contain a description of the management practices that will be used to prevent these pollutants from being discharged into surface water in the state or waters of the U.S.

NOTE: Construction support activities can also include vehicle repair areas, fueling areas, etc. that are present at a construction site solely for the support construction activities and are only used by operators at the construction site.

The SWP3 is intended to serve as a road map for how the construction operator will comply with the effluent limits and other conditions of this permit. Additional portions of the effluent limits are established in Part IV. of the permit.

Section A. Shared SWP3 Development

For more effective coordination of BMPs and opportunities for cost sharing, a cooperative effort by the different operators at a site is encouraged. Operators of small and large construction activities must independently obtain authorization under this permit but may work together with other regulated operators at the construction site to prepare and implement a single, comprehensive SWP3, which can be shared by some or all operators, for the construction activities that each of the operators are performing at the entire construction site.

1. The SWP3 must include the following:
 - (a) for small construction activities – the name of each operator that participates in the shared SWP3;
 - (b) for large construction activities – the name of each operator that participates in the shared SWP3, the general permit authorization numbers of each operator (or the date that the NOI was submitted to TCEQ by each operator that has not received an authorization number for coverage under this permit); and
 - (c) for large and small construction activities – the signature of each operator participating in the shared SWP3.
2. The SWP3 must clearly indicate which operator is responsible for satisfying each shared requirement of the SWP3. If the responsibility for satisfying a requirement is not described in the plan, then each permittee is entirely responsible for meeting the requirement within the boundaries of the construction site where they perform construction activities. The SWP3 must clearly describe responsibilities for meeting each requirement in shared or common areas.
3. The SWP3 may provide that one operator is responsible for preparation of a SWP3 in compliance with the CGP, and another operator is responsible for implementation of the SWP3 at the project site.

Section B. Responsibilities of Operators

1. Secondary Operators and Primary Operators with Control Over Construction Plans and Specifications

All secondary operators and primary operators with control over construction plans and specifications shall:

- (a) ensure the project specifications allow or provide that adequate BMPs are developed to meet the requirements of Part III of this general permit;
- (b) ensure that the SWP3 indicates the areas of the project where they have control over project specifications, including the ability to make modifications in specifications;
- (c) ensure that all other operators affected by modifications in project specifications are notified in a timely manner so that those operators may modify their BMP s as necessary to remain compliant with the conditions of this general permit; and

- (d) ensure that the SWP3 for portions of the project where each operator has control indicates the name and site-specific TPDES authorization number(s) for operators with the day-to-day operational control over those activities necessary to ensure compliance with the SWP3 and other permit conditions. If a primary operator has not been authorized or has abandoned the site, the secondary operator is considered to be the responsible party and must obtain authorization as a primary operator under the permit, until the authority for day-to-day operational control is transferred to another primary operator. The new primary operator must update or develop a new SWP3 that will reflect the transfer of operational control and include any additional updates to the SWP3 to meet requirements of the permit.

2. Primary Operators with Day-to-Day Operational Control

Primary operators with day-to-day operational control of those activities at a project that are necessary to ensure compliance with an SWP3 and other permit conditions must ensure that the SWP3 accomplishes the following requirements:

- (a) meets the requirements of this general permit for those portions of the project where they are operators;
- (b) identifies the parties responsible for implementation of BMPs described in the SWP3;
- (c) indicates areas of the project where they have operational control over day-to-day activities; and
- (d) the name and site-specific TPDES authorization number of the parties with control over project specifications, including the ability to make modifications in specifications for areas where they have operational control over day-to-day activities.

Section C. Deadlines for SWP3 Preparation, Implementation, and Compliance

The SWP3 must be prepared prior to obtaining authorization under this general permit, and implemented prior to commencing construction activities that result in soil disturbance. The SWP3 must be prepared so that it provides for compliance with the terms and conditions of this general permit.

Section D. Plan Review and Making Plans Available

1. The SWP3 must be retained on-site at the construction site or, if the site is inactive or does not have an on-site location to store the plan, a notice must be posted describing the location of the SWP3. The SWP3 must be made readily available at the time of an on-site inspection to: the executive director; a federal, state, or local agency approving sediment and erosion plans, grading plans, or stormwater management plans; local government officials; and the operator of a municipal separate storm sewer receiving discharges from the site. If the SWP3 is retained off-site, then it shall be made available as soon as reasonably possible. In most instances, it is reasonable that the SWP3 shall be made available within 24 hours of the request.

NOTE: The SWP3 may be prepared and kept electronically, rather than in paper form, if the records are: (a) in a format that can be read in a similar manner as a paper record; (b) legally valid with no less evidentiary value than their paper equivalent; and (c) immediately accessible to the inspector during an inspection to the same extent as a paper copy stored at the site would be, if the records were stored in paper form.

2. Operators with authorization for construction activity under this general permit must post a TCEQ site notice at the construction site at a place readily available for viewing by the general public, and local, state, and federal authorities.

- (a) Primary and secondary operators of large construction activities must each post a TCEQ construction site notice, respective to their role as an operator at the construction site, as required above and according to requirements in Part II.E.3. of this general permit.
 - (b) Primary and secondary operators of small construction activities must post the TCEQ site notice as required in Part III.D.2.(a) above and for the specific type of small construction described in Part II.E.1. and 2. of the permit.
 - (c) If the construction project is a linear construction project, such as a pipeline or highway, the notices must be placed in a publicly accessible location near where construction is actively underway. TCEQ construction site notices for small and large construction activities at these linear construction sites may be relocated, as necessary, along the length of the project, but must still be readily available for viewing by the general public; local, state, and federal authorities; and contain the following information:
 - i. the site-specific TPDES authorization number for the project if assigned;
 - ii. the operator name, contact name, and contact phone number;
 - iii. a brief description of the project; and
 - iv. the location of the SWP3.
3. This permit does not provide the general public with any right to trespass on a construction site for any reason, including inspection of a site; nor does this permit require that permittees allow members of the general public access to a construction site.

Section E. Revisions and Updates to SWP3s

The permittee must revise or update the SWP3, including the site map, within seven (7) days of when any of the following occurs:

1. a change in design, construction, operation, or maintenance that has a significant effect on the discharge of pollutants and that has not been previously addressed in the SWP3;
2. changing site conditions based on updated plans and specifications, new operators, new areas of responsibility, and changes in BMPs; or
3. results of inspections or investigations by construction site personnel authorized by the permittee, operators of a municipal separate storm sewer system receiving the discharge, authorized TCEQ personnel, or a federal, state or local agency approving sediment and erosion plans indicate the SWP3 is proving ineffective in eliminating or significantly minimizing pollutants in discharges authorized under this general permit.

Section F. Contents of SWP3

The SWP3 must be developed and implemented by primary operators of small and large construction activities and include, at a minimum, the information described in this section and must comply with the construction and development effluent guidelines in Part IV. of the general permit.

1. A site or project description, which includes the following information:
 - (a) a description of the nature of the construction activity;
 - (b) a list of potential pollutants and their sources;
 - (c) a description of the intended schedule or sequence of activities that will disturb soils for major portions of the site, including estimated start dates and duration of activities;

- (d) the total number of acres of the entire property and the total number of acres where construction activities will occur, including areas where construction support activities (defined in Part I.B. of this general permit) occur;
- (e) data describing the soil or the quality of any discharge from the site;
- (f) a map showing the general location of the site (e.g., a portion of a city or county map);
- (g) a detailed site map (or maps) indicating the following:
 - i. property boundary(ies);
 - ii. drainage patterns and approximate slopes anticipated before and after major grading activities;
 - iii. areas where soil disturbance will occur (note any phasing), including any demolition activities;
 - iv. locations of all controls and buffers, either planned or in place;
 - v. locations where temporary or permanent stabilization practices are expected to be used;
 - vi. locations of construction support activities, including those located off-site;
 - vii. surface waters (including wetlands) either at, adjacent, or in close proximity to the site, and also indicate whether those waters are impaired;

NOTE: Surface waters adjacent to or in close proximity to the site means any receiving waters within the site and all receiving waters within one mile downstream of the site's discharge point(s).

- viii. locations where stormwater discharges from the site directly to a surface water body or a municipal separate storm sewer system;
 - ix. vehicle wash areas; and
 - x. designated points on the site where vehicles will exit onto paved roads (for instance, this applies to construction transition from unstable dirt areas to exterior paved roads).
- Where the amount of information required to be included on the map would result in a single map being difficult to read and interpret, the operator shall develop a series of maps that collectively include the required information.
- (h) the location and description of support activities authorized under the permittee's NOI, including asphalt plants, concrete plants, and other activities providing support to the construction site that is authorized under this general permit;
 - (i) the name of receiving waters at or near the site that may be disturbed or that may receive discharges from disturbed areas of the project;
 - (j) a copy of this TPDES general permit (an electronic copy of this TPDES general permit or a current link to this TPDES general permit on the TCEQ webpage is acceptable);
 - (k) the NOI and the acknowledgement of provisional and non-provisional authorization for primary operators of large construction sites, and the TCEQ site notice for small construction sites and for secondary operators of large construction sites;
 - (l) if signatory authority is delegated by an authorized representative, then a copy of the formal notification to TCEQ, as required by 30 TAC 305.128 relating to Signatories to Reports must be filed in the SWP3 and made available for review upon request by TCEQ or local MS4 Operator. For primary operators of large construction activities, the formal notification to TCEQ must be submitted either electronically through

STEERS, TCEQ's electronic reporting system, or, if qualifying for an electronic reporting waiver, by paper on a Delegation of Signatories form. For operators or small construction activities, the formal notification to TCEQ must be submitted by paper on a Delegation of Signatories form.

- (m) stormwater and allowable non-stormwater discharge locations, including storm drain inlets on site and in the immediate vicinity of the construction site where construction support activities will occur; and
 - (n) locations of all pollutant-generating activities at the construction site and where construction support activities will occur, such as the following: Paving operations; concrete, paint and stucco washout and water disposal; solid waste storage and disposal; and dewatering operations.
2. A description of the BMPs that will be used to minimize pollution in runoff.

The description must identify the general timing or sequence for installation and implementation. At a minimum, the description must include the following components:

(a) General Requirements

- i. Erosion and sediment controls must be designed to retain sediment on-site to the extent practicable with consideration for local topography, soil type, and rainfall.
- ii. Control measures must be properly selected, installed, and maintained according to good engineering practices, and the manufacturer's or designer's specifications.
- iii. Controls must be developed to minimize the offsite transport of litter, construction debris, construction materials, and other pollutants required of Part IV.D.

(b) Erosion Control and Stabilization Practices

The SWP3 must include a description of temporary and permanent erosion control and stabilization practices for the construction site, where small or large construction activity will occur. The erosion control and stabilization practices selected by the permittee must be compliant with the requirements for sediment and erosion control, located in Part IV. of this permit. The description of the SWP3 must also include a schedule of when the practices will be implemented. Site plans must ensure that existing vegetation at the construction site is preserved where it is possible.

- i. Erosion control and stabilization practices may include but are not limited to: establishment of temporary or permanent vegetation, mulching, geotextiles, sod stabilization, vegetative buffer strips, protection of existing trees and vegetation, slope texturing, temporary velocity dissipation devices, flow diversion mechanisms, and other similar measures.
- ii. The following records must be maintained and either attached to or referenced in the SWP3, and made readily available upon request to the parties listed in Part III.D.1 of this general permit:
 - (A) the dates when major grading activities occur;
 - (B) the dates when construction activities temporarily or permanently cease on a portion of the site; and
 - (C) the dates when stabilization measures are initiated.
- iii. Erosion control and stabilization measures must be initiated immediately in portions of the site where construction activities have temporarily ceased and will not resume for a period exceeding fourteen (14) calendar days. Stabilization

measures that provide a protective cover must be initiated immediately in portions of the site where construction activities have permanently ceased. The term “immediately” is used to define the deadline for initiating stabilization measures. In the context of this requirement, “immediately” means as soon as practicable, but no later than the end of the next work day, following the day when the earth-disturbing activities have temporarily or permanently ceased. Except as provided in (A) through (D) below, these measures must be completed as soon as practicable, but no more than fourteen (14) calendar days after the initiation of soil stabilization measures:

- (A) where the immediate initiation of vegetative stabilization measures after construction activity has temporarily or permanently ceased due to frozen conditions, non-vegetative controls must be implemented until thawing conditions (as defined in Part I.B. of this general permit) are present, and vegetative stabilization measures can be initiated as soon as practicable.
 - (B) in arid areas, semi-arid areas, or drought-stricken areas, as they are defined in Part I.B. of this general permit, where the immediate initiation of vegetative stabilization measures after construction activity has temporarily or permanently ceased or is precluded by arid conditions, other types of erosion control and stabilization measures must be initiated at the site as soon as practicable. Where vegetative controls are infeasible due to arid conditions, and within fourteen (14) calendar days of a temporary or permanent cessation of construction activity in any portion of the site, the operator shall immediately install non-vegetative erosion controls in areas of the construction site where construction activity is complete or has ceased. If non-vegetative controls are infeasible, the operator shall install temporary sediment controls as required in Part III.F.2.(b)iii.(C) below.
 - (C) in areas where non-vegetative controls are infeasible, the operator may alternatively utilize temporary perimeter controls. The operator must document in the SWP3 the reason why stabilization measures are not feasible, and must demonstrate that the perimeter controls will retain sediment on site to the extent practicable. The operator must continue to inspect the BMPs at the frequencies established in Part III.F.8.(c) for unstabilized sites.
 - (D) the requirement for permittees to initiate stabilization is triggered as soon as it is known with reasonable certainty that construction activity at the site or in certain areas of the site will be stopped for 14 or more additional calendar days. If the initiation or completion of vegetative stabilization is prevented by circumstances beyond the control of the permittee, the permittee must employ and implement alternative stabilization measures immediately. When conditions at the site changes that would allow for vegetative stabilization, then the permittee must initiate or complete vegetative stabilization as soon as practicable.
- iv. Final stabilization must be achieved prior to termination of permit coverage.
 - v. TCEQ does not expect that temporary or permanent stabilization measures to be applied to areas that are intended to be left un-vegetated or un-stabilized following construction (e.g., dirt access roads, utility pole pads, areas being used for storage of vehicles, equipment, or materials).

(c) Sediment Control Practices

The SWP₃ must include a description of any sediment control practices used to remove eroded soils from stormwater runoff, including the general timing or sequence for implementation of controls. Controls selected by the permittee must be compliant with the requirements in Part IV. of this permit.

i. Sites With Drainage Areas of Ten (10) or More Acres

(A) Sedimentation Basin(s) or Impoundments

- (1) A sedimentation basin or similar impoundment is required, where feasible, for a common drainage location that serves an area with ten (10) or more acres disturbed at one time. A sedimentation basin or impoundment may be temporary or permanent, and must provide sufficient storage to contain a calculated volume of runoff from a 2-year, 24-hour storm from each disturbed acre drained. When calculating the volume of runoff from a 2-year, 24-hour storm event, it is not required to include the flows from offsite areas and flow from onsite areas that are either undisturbed or have already undergone permanent stabilization, if these flows are diverted around both the disturbed areas of the site and the sediment basin or similar impoundment. Capacity calculations shall be included in the SWP₃. Sedimentation basins must be designed for and appropriate for controlling runoff at the site and existing detention or retention ponds at the site may not be appropriate.
- (2) Where rainfall data is not available, or a calculation cannot be performed, the sedimentation basin must provide at least 3,600 cubic feet of storage per acre drained until final stabilization of the site.
- (3) If a sedimentation basin or impoundment is not feasible, then the permittee shall provide equivalent control measures until final stabilization of the site. In determining whether installing a sediment basin or impoundment is feasible, the permittee may consider factors such as site soils, slope, available area, public safety, precipitation patterns, site geometry, site vegetation, infiltration capacity, geotechnical factors, depth to groundwater, and other similar considerations. The permittee shall document the reason that the sediment basins or impoundments are not feasible, and shall utilize equivalent control measures, which may include a series of smaller sediment basins or impoundments.
- (4) Unless infeasible, when discharging from sedimentation basins and impoundments, the permittee shall utilize outlet structures that withdraw water from the surface.

(B) Perimeter Controls: At a minimum, silt fences, vegetative buffer strips, or equivalent sediment controls are required for all down slope boundaries of the construction area, and for those side slope boundaries deemed appropriate as dictated by individual site conditions.

ii. Controls for Sites with Drainage Areas Less than Ten (10) Acres:

(A) Sediment traps and sediment basins may be used to control solids in stormwater runoff for drainage locations serving less than ten (10) acres. At a minimum, silt fences, vegetative buffer strips, or equivalent sediment controls are required for all down slope boundaries of the construction area, and for those side slope boundaries deemed appropriate as dictated by individual site conditions.

- (B) Alternatively, a sediment basin that provides storage for a calculated volume of runoff from a 2-year, 24-hour storm from each disturbed acre drained may be utilized. Where rainfall data is not available or a calculation cannot be performed, a temporary or permanent sediment basin providing 3,600 cubic feet of storage per acre drained may be provided. If a calculation is performed, then the calculation shall be included in the SWP₃.
- (C) If sedimentation basins or impoundments are used, the permittee shall comply with the requirements in Part IV.F. of this general permit.

3. Description of Permanent Stormwater Controls

A description of any stormwater control measures that will be installed during the construction process to control pollutants in stormwater discharges that may occur after construction operations have been completed must be included in the SWP₃. Permittees are responsible for the installation and maintenance of stormwater management measures, as follows:

- (a) permittees authorized under the permit for small construction activities are responsible for the installation and maintenance of stormwater control measures prior to final stabilization of the site; or
- (b) permittees authorized under the permit for large construction activities are responsible for the installation and maintenance of stormwater control measures prior to final stabilization of the site and prior to submission of an NOT.

4. Other Required Controls and BMPs

- (a) Permittees shall minimize, to the extent practicable, the off-site vehicle tracking of sediments and dust. The SWP₃ shall include a description of controls utilized to control the generation of pollutants that could be discharged in stormwater from the site.
- (b) The SWP₃ must include a description of construction and waste materials expected to be stored on-site and a description of controls to minimize pollutants from these materials.
- (c) The SWP₃ must include a description of potential pollutant sources in discharges of stormwater from all areas of the construction site where construction activity, including construction support activities, will be located, and a description of controls and measures that will be implemented at those sites to minimize pollutant discharges.
- (d) Permittees shall place velocity dissipation devices at discharge locations and along the length of any outfall channel (i.e., runoff conveyance) to provide a non-erosive flow velocity from the structure to a water course, so that the natural physical and biological characteristics and functions are maintained and protected.
- (e) Permittees shall design and utilize appropriate controls in accordance with Part IV. of this permit to minimize the offsite transport of suspended sediments and other pollutants if it is necessary to pump or channel standing water from the site.
- (f) Permittees shall ensure that all other required controls and BMPs comply with all of the requirements of Part IV. of this general permit.
- (g) For demolition of any structure with at least 10,000 square feet of floor space that was built or renovated before January 1, 1980, and the receiving waterbody is impaired for polychlorinated biphenyls (PCBs):
 - i. implement controls to minimize the exposure of PCB-containing building materials, including paint, caulk, and pre-1980 fluorescent lighting fixtures to precipitation and to stormwater; and

- ii. ensure that disposal of such materials is performed in compliance with applicable state, federal, and local laws.
5. Documentation of Compliance with Approved State and Local Plans
 - (a) Permittees must ensure that the SWP3 is consistent with requirements specified in applicable sediment and erosion site plans or site permits, or stormwater management site plans or site permits approved by federal, state, or local officials.
 - (b) SWP3s must be updated as necessary to remain consistent with any changes applicable to protecting surface water resources in sediment erosion site plans or site permits, or stormwater management site plans or site permits approved by state or local official for which the permittee receives written notice.
 - (c) If the permittee is required to prepare a separate management plan, including but not limited to a WPAP or Contributing Zone Plan in accordance with 30 TAC Chapter 213 (related to the Edwards Aquifer), then a copy of that plan must be either included in the SWP3 or made readily available upon request to authorized personnel of the TCEQ. The permittee shall maintain a copy of the approval letter for the plan in its SWP3.
6. Maintenance Requirements
 - (a) All protective measures identified in the SWP3 must be maintained in effective operating condition. If, through inspections or other means, as soon as the permittee determines that BMPs are not operating effectively, then the permittee shall perform maintenance as necessary to maintain the continued effectiveness of stormwater controls, and prior to the next rain event if feasible. If maintenance prior to the next anticipated storm event is impracticable, the reason shall be documented in the SWP3 and maintenance must be scheduled and accomplished as soon as practicable. Erosion and sediment controls that have been intentionally disabled, run-over, removed, or otherwise rendered ineffective must be replaced or corrected immediately upon discovery.
 - (b) If periodic inspections or other information indicates a control has been used incorrectly, is performing inadequately, or is damaged, then the operator shall replace or modify the control as soon as practicable after making the discovery.
 - (c) Sediment must be removed from sediment traps and sedimentation ponds no later than the time that design capacity has been reduced by 50%. For perimeter controls such as silt fences, berms, etc., the trapped sediment must be removed before it reaches 50% of the above-ground height.
 - (d) If sediment escapes the site, accumulations must be removed at a frequency that minimizes off-site impacts, and prior to the next rain event, if feasible. If the permittee does not own or operate the off-site conveyance, then the permittee shall work with the owner or operator of the property to remove the sediment.
7. Observation and Evaluation of Dewatering Controls Pursuant to Part IV.C. of this General Permit
 - (a) Personnel provided by the permittee must observe and evaluate dewatering controls at a minimum of once per day on the days where dewatering discharges from the construction site occur. Personnel conducting these evaluations must be knowledgeable of this general permit, the construction activities at the site, and the SWP3 for the site. Personnel conducting these evaluations are not required to have signatory authority for reports under 30 TAC § 305.128 (relating to Signatories to Reports).

(b) Requirements for Observations and Evaluations

- i. A report summarizing the scope of any observation and evaluation must be completed within 24-hours following the evaluation. The report must also include, at a minimum, the following:
 - (A) date of the observations and evaluation;
 - (B) name(s) and title(s) of personnel making the observations and evaluation;
 - (C) approximate times that the dewatering discharge began and ended on the day of evaluation, or if the dewatering discharge is a continuous discharge that continues after normal business hours, indicate that the discharge is continuous (this information can be reported by personnel initiating the dewatering discharge);
 - (D) estimates of the rate (in gallons per day) of discharge on the day of evaluation;
 - (E) whether or not any indications of pollutant discharge were observed at the point of discharge (e.g., foam, oil sheen, noticeable odor, floating solids, suspended sediments, or other obvious indicators of stormwater pollution); and
 - (F) major observations, including: the locations of where erosion and discharges of sediment or other pollutants from the site have occurred; locations of BMPs that need to be maintained; locations of BMPs that failed to operate as designed or proved inadequate for a particular location; and locations where additional BMPs are needed.
- ii. Actions taken as a result of evaluations, including the date(s) of actions taken, must be described within, and retained as a part of, the SWP3. Reports must identify any incidents of non-compliance. Where a report does not identify any incidents of non-compliance, the report must contain a certification that the facility or site is in compliance with the SWP3 and this permit. The report must be retained as part of the SWP3 and signed by the person and in the manner required by 30 TAC § 305.128 (relating to Signatories to Reports).
- iii. The names and qualifications of personnel making the evaluations for the permittee may be documented once in the SWP3 rather than being included in each report.

8. Inspections of All Controls

- (a) Personnel provided by the permittee must inspect disturbed areas (cleared, graded, or excavated) of the construction site that do not meet the requirements of final stabilization in this general permit, all locations where stabilization measures have been implemented, areas of construction support activity covered under this permit, stormwater controls (including pollution prevention controls) for evidence of, or the potential for, the discharge of pollutants, areas where stormwater typically flows within the construction site, and points of discharge from the construction site.
 - i. Personnel conducting these inspections must be knowledgeable of this general permit, the construction activities at the site, and the SWP3 for the site.
 - ii. Personnel conducting these inspections are not required to have signatory authority for inspection reports under 30 TAC § 305.128 (relating to Signatories to Reports).

(b) Requirements for Inspections

- i. Inspect all stormwater controls (including sediment and erosion control measures identified in the SWP₃) to ensure that they are installed properly, appear to be operational, and minimizing pollutants in discharges, as intended.
- ii. Identify locations on the construction site where new or modified stormwater controls are necessary.
- iii. Check for signs of visible erosion and sedimentation that can be attributed to the points of discharge where discharges leave the construction site or discharge into any surface water in the state flowing within or adjacent to the construction site.
- iv. Identify any incidents of noncompliance observed during the inspection.
- v. Inspect locations where vehicles enter or exit the site for evidence of off-site sediment tracking.
- vi. If an inspection is performed when discharges from the construction site are occurring: identify all discharge points at the site, and observe and document the visual quality of the discharge (i.e., color, odor, floating, settled, or suspended solids, foam, oil sheen, and other such indicators of pollutants in stormwater).
- vii. Complete any necessary maintenance needed, based on the results of the inspection and in accordance with the requirements listed in Part III.F.6. above.

(c) Inspection frequencies:

- i. Inspections of construction sites must be conducted at least once every fourteen (14) calendar days and within 24 hours of the end of a storm event of 0.5 inches or greater, unless as otherwise provided below in Part III.F.8.(c)ii. – v. below.
 - (A) If a storm event produces 0.5 inches or more of rain within a 24-hour period (including when there are multiple, smaller storms that alone produce less than 0.5 inches but together produce 0.5 inches or more in 24 hours), you are required to conduct one inspection within 24 hours of when 0.5 inches of rain or more has fallen. When the 24-hour inspection time frame occurs entirely outside of normal working hours, you must conduct an inspection by no later than the end of the next business day.
 - (B) If a storm event produces 0.5 inches or more of rain within a 24-hour period on the first day of a storm and continues to produce 0.5 inches or more of rain on subsequent days, you must conduct an inspection within 24 hours of the first day of the storm and within 24 hours after the last day of the storm that produces 0.5 inches or more of rain (i.e., only two (2) inspections would be required for such a storm event). When the 24-hour inspection time frame occurs entirely outside of normal working hours, you must conduct an inspection by no later than the end of the next business day.
- ii. Inspection frequencies must be conducted at least once every month in areas of the construction site that meet final stabilization or have been temporarily stabilized.
- iii. Inspection frequencies for construction sites, where runoff is unlikely due to the occurrence of frozen conditions at the site, must be conducted at least once every month until thawing conditions begin to occur (see definitions for thawing conditions in Part I.B.). The SWP₃ must also contain a record of the approximate beginning and ending dates of when frozen conditions occurred at the site, which resulted in inspections being conducted monthly, while those

conditions persisted, instead of at the interval of once every fourteen (14) calendar days and within 24 hours of the end of a storm event of 0.5 inches or greater.

- iv. In arid, semi-arid, or drought-stricken areas, inspections must be conducted at least once every month and within 24 hours after the end of a storm event of 0.5 inches or greater. The SWP3 must also contain a record of the total rainfall measured, as well as the approximate beginning and ending dates of when drought conditions occurred at the site, which resulted in inspections being conducted monthly, while those conditions persisted, instead of at the interval of once every fourteen (14) calendar days and within 24 hours of the end of a storm event of 0.5 inches or greater.
 - v. As an alternative to the inspection schedule in Part III.F.8.(c)i. above, the SWP3 may be developed to require that these inspections will occur at least once every seven (7) calendar days. If this alternative schedule is developed, then the inspection must occur regardless of whether or not there has been a rainfall event since the previous inspection.
 - vi. The inspection procedures described in Part III.F.8.(c)i. – v above can be performed at the frequencies and under the applicable conditions indicated for each schedule option, provided that the SWP3 reflects the current schedule and that any changes to the schedule are made in accordance with the following provisions: the inspection frequency schedule can only be changed a maximum of once per calendar month and implemented within the first five (5) business days of a calendar month; and the reason for the schedule change documented in the SWP3 (e.g., end of “dry” season and beginning of “wet” season).
- (d) Utility line installation, pipeline construction, and other examples of long, narrow, linear construction activities may provide inspection personnel with limited access to the areas described in Part III.F.8.(a) above.
- i. Inspection of linear construction sites could require the use of vehicles that could compromise areas of temporary or permanent stabilization, cause additional disturbance of soils, and result in the increase the potential for erosion. In these circumstances, controls must be inspected at least once every fourteen (14) calendar days and within 24 hours of the end of a storm event of 0.5 inches or greater, but representative inspections may be performed.
 - ii. For representative inspections, personnel must inspect controls along the construction site for 0.25 mile above and below each access point where a roadway, undisturbed right-of-way, or other similar feature intersects the construction site and allows access to the areas described in Part III.F.8.(a) above. The conditions of the controls along each inspected 0.25-mile portion may be considered as representative of the condition of controls along that reach extending from the end of the 0.25-mile portion to either the end of the next 0.25-mile inspected portion, or to the end of the project, whichever occurs first.

As an alternative to the inspection schedule described in Part III.F.8.(c)i. above, the SWP3 may be developed to require that these inspections will occur at least once every seven (7) calendar days. If this alternative schedule is developed, the inspection must occur regardless of whether or not there has been a rainfall event since the previous inspection.

- iii. the SWP3 for a linear construction site must reflect the current inspection schedule. Any changes to the inspection schedule must be made in accordance with the following provisions:
 - (A) the schedule may be changed a maximum of one time each month;

- (B) the schedule change must be implemented at the beginning of a calendar month, and
 - (C) the reason for the schedule change must be documented in the SWP3 (e.g., end of “dry” season and beginning of “wet” season).
- (e) Adverse Conditions.
- Requirements for inspections may be temporarily suspended for adverse conditions. Adverse conditions are conditions that are either dangerous to personnel (e.g., high wind, excessive lightning) or conditions that prohibit access to the site (e.g., flooding, freezing conditions). Adverse conditions that result in the temporary suspension of a permit requirement to inspect must be documented and included as part of the SWP3. Documentation must include:
- i. the date and time of the adverse condition,
 - ii. names of personnel that witnessed the adverse condition, and
 - iii. a narrative for the nature of the adverse condition.
- (f) In the event of flooding or other adverse conditions which prohibit access to the inspection sites, inspections must be conducted as soon as access is practicable. Inspection Reports.
- i. A report summarizing the scope of any inspection must be completed within 24-hours following the inspection. The report must also include the date(s) of the inspection and major observations relating to the implementation of the SWP3. Major observations in the report must include: the locations of where erosion and discharges of sediment or other pollutants from the site have occurred; locations of BMPs that need to be maintained; locations of BMPs that failed to operate as designed or proved inadequate for a particular location; and locations where additional BMPs are needed.
 - ii. Actions taken as a result of inspections, including the date(s) of actions taken, must be described within, and retained as a part of, the SWP3. Reports must identify any incidents of non-compliance. Where a report does not identify any incidents of non-compliance, the report must contain a certification that the facility or site is in compliance with the SWP3 and this permit. The report must be retained as part of the SWP3 and signed by the person and in the manner required by 30 TAC § 305.128 (relating to Signatories to Reports).
 - iii. The names and qualifications of personnel making the inspections for the permittee may be documented once in the SWP3 rather than being included in each report.
- (g) The SWP3 must be modified based on the results of inspections, as necessary, to better control pollutants in runoff. Revisions to the SWP3 must be completed within seven (7) calendar days following the inspection. If existing BMPs are modified or if additional BMPs are necessary, an implementation schedule must be described in the SWP3 and wherever possible those changes implemented before the next storm event. If implementation before the next anticipated storm event is impracticable, these changes must be implemented as soon as practicable. If necessary, modify your site map to reflect changes to your stormwater controls that are no longer accurately reflected on the current site map.
9. The SWP3 must identify and ensure the implementation of appropriate pollution prevention measures for all eligible non-stormwater components of the discharge, as listed in Part II.A.3. of this permit.
10. The SWP3 must include the information required in Part III.B. of this general permit.

11. The SWP3 must include pollution prevention procedures that comply with Part IV.D. of this general permit.

Part IV. Erosion and Sediment Control Requirements Applicable to All Sites

Except as provided in 40 CFR §§ 125.30-125.32, any discharge regulated under this general permit, with the exception of sites that obtained waivers based on low rainfall erosivity, must achieve, at a minimum, the following effluent limitations representing the degree of effluent reduction attainable by application of the best practicable control technology currently available (BPT). The BPT are also required by and must satisfy the Effluent Limitations Guideline (ELG) permitting requirement for application of 40 CFR § 450.24 New Source Performance Standards (NSPS), 40 CFR § 450.22 Best Available Technology Economically Achievable (BAT), and 40 CFR § 450.23 Best Conventional Pollutant Control Technology (BCT).

Section A. Erosion and Sediment Controls

Design, install, and maintain effective erosion controls and sediment controls to minimize the discharge of pollutants. At a minimum, such controls must be designed, installed, and maintained to:

1. control stormwater volume and velocity within the site to minimize soil erosion in order to minimize pollutant discharges;
2. control stormwater discharges, including both peak flowrates and total stormwater volume, to minimize channel and streambank erosion and scour in the immediate vicinity of discharge point(s);
3. minimize the amount of soil exposed during construction activity;
4. minimize the disturbance of steep slopes;
5. minimize sediment discharges from the site. The design, installation, and maintenance of erosion and sediment controls must address factors such as the amount, frequency, intensity and duration of precipitation, the nature of resulting stormwater runoff, and soil characteristics, including the range of soil particle sizes expected to be present on the site;
6. provide and maintain appropriate natural buffers around surface water in the state. Direct stormwater to vegetated areas and maximize stormwater infiltration to reduce pollutant discharges, unless infeasible. If providing buffers is infeasible, the permittee shall document the reason that natural buffers are infeasible and shall implement additional erosion and sediment controls to reduce sediment load;
7. preserve native topsoil at the site, unless the intended function of a specific area of the site dictates that the topsoil be disturbed or removed, or it is infeasible; and
8. minimize soil compaction. In areas of the construction site where final vegetative stabilization will occur or where infiltration practices will be installed, either:
 - (a) restrict vehicle and equipment use to avoid soil compaction; or
 - (b) prior to seeding or planting areas of exposed soil that have been compacted, use techniques that condition the soils to support vegetative growth, if necessary and feasible.

Minimizing soil compaction is not required where the intended function of a specific area of the site dictates that it be compacted.

9. TCEQ does not consider stormwater control features (e.g., stormwater conveyance channels, storm drain inlets, sediment basins) to constitute "surface water" for the purposes of triggering the buffer requirement in Part IV.A.(6) above.

Section B. Soil Stabilization

Stabilization of disturbed areas must, at a minimum, be initiated immediately whenever any clearing, grading, excavating, or other earth disturbing activities have permanently ceased on any portion of the site, or temporarily ceased on any portion of the site and will not resume for a period exceeding fourteen (14) calendar days. In the context of this requirement, “immediately” means as soon as practicable, but no later than the end of the next workday, following the day when the earth-disturbing activities have temporarily or permanently ceased. Temporary stabilization must be completed no more than fourteen (14) calendar days after initiation of soil stabilization measures, and final stabilization must be achieved prior to termination of permit coverage. In arid, semi-arid, and drought-stricken areas where initiating vegetative stabilization measures immediately is infeasible, alternative non-vegetative stabilization measures must be employed as soon as practicable. Refer to Part III.F.2.(b) for complete erosion control and stabilization practice requirements. In limited circumstances, stabilization may not be required if the intended function of a specific area of the site necessitates that it remain disturbed.

Section C. Dewatering

Discharges from dewatering activities, including discharges from dewatering of trenches and excavations, are prohibited, unless managed by appropriate controls to address sediment and prevent erosion. Operators must observe and evaluate the dewatering controls once per day while the dewatering discharge occurs as described in Part III.F.7. of this general permit.

Section D. Pollution Prevention Measures

Design, install, implement, and maintain effective pollution prevention measures to minimize the discharge of pollutants. At a minimum, such measures must be designed, installed, implemented, and maintained to:

1. minimize the discharge of pollutants from equipment and vehicle washing, wheel wash water, and other wash waters. Wash waters must be treated in a sediment basin or alternative control that provides equivalent or better treatment prior to discharge;
2. minimize the exposure of building materials, building products, construction wastes, trash, landscape materials, fertilizers, pesticides, herbicides, detergents, sanitary waste, and other materials present on the site to precipitation and to stormwater;
3. minimize the exposure of waste materials by closing waste container lids at the end of the workday and during storm events. For waste containers that do not have lids, where the container itself is not sufficiently secure enough to prevent the discharge of pollutants absent a cover and could leak, the permittee must provide either a cover (e.g., a tarp, plastic sheeting, temporary roof) to minimize exposure of wastes to precipitation, stormwater, and wind, or a similarly effective means designed to minimize the discharge of pollutants (e.g., secondary containment). Minimization of exposure is not required in cases where the exposure to precipitation and to stormwater will not result in a discharge of pollutants, or where exposure of a specific material or product poses little risk of stormwater contamination (such as final products and materials intended for outdoor use);
4. minimize exposure of wastes by implementing good housekeeping measures. Wastes must be cleaned up and disposed of in designated waste containers on days of operation at the site. Wastes must be cleaned up immediately if containers overflow;

5. minimize the discharge of pollutants from spills and leaks and implement chemical spill and leak prevention and response procedures. Where a leak, spill, or other release containing a hazardous substance or oil in an amount equal to or in excess of a reportable quantity established under either 40 CFR Part 110, 40 CFR Part 117, or 40 CFR Part 302 occurs during a 24-hour period, you must notify the National Response Center (NRC) at (800) 424-8802 in accordance with the requirements of 40 CFR Part 110, 40 CFR Part 117, and 40 CFR Part 302 as soon as you have knowledge of the release. You must also, within seven (7) calendar days of knowledge of the release, provide a description of the release, the circumstances leading to the release, and the date of the release; and
6. minimize exposure of sanitary waste by positioning portable toilets so that they are secure and will not be tipped or knocked over, and so that they are located away from surface water in the state and stormwater inlets or conveyances.

Section E. Prohibited Discharges

The following discharges are prohibited:

1. wastewater from wash out of concrete, unless managed by an appropriate control;
2. wastewater from wash out and cleanout of stucco, paint, form release oils, curing compounds and other construction materials;
3. fuels, oils, or other pollutants used in vehicle and equipment operation and maintenance;
4. soaps or solvents used in vehicle and equipment washing; and
5. toxic or hazardous substances from a spill or other release.

Section F. Surface Outlets

When discharging from basins and impoundments, utilize outlet structures that withdraw water from the surface, unless infeasible. If infeasible, the permittee must provide documentation in the SWP3 to support the determination, including the specific conditions or time periods when this exception will apply.

Part V. Stormwater Runoff from Concrete Batch Plants

Discharges of stormwater runoff from concrete batch plants present at regulated construction sites and operated as a construction support activity may be authorized under the provisions of this general permit, provided that the following requirements are met for concrete batch plant(s) authorized under this permit. Only the discharges of stormwater runoff and non-stormwater from concrete batch plants that meet the requirements of a construction support activity can be authorized under this permit (see the requirements for “Non-Stormwater Discharges” in Part II.A.3. and “Discharges of Stormwater Associated with Construction Support Activity” in Part II.A.2.).

If discharges of stormwater runoff or non-stormwater from concrete batch plants are not authorized under this general permit, then discharges must be authorized under an alternative general permit or individual permit [see the requirement in Part II.A.2.(c)].

This permit does not authorize the discharge or land disposal of any wastewater from concrete batch plants at regulated construction sites. Authorization for these wastes must be obtained under an individual permit or an alternative general permit.

Section A. Benchmark Sampling Requirements

1. Operators of concrete batch plants authorized under this general permit shall sample the stormwater runoff from the concrete batch plants according to the requirements of this section of this general permit, and must conduct evaluations on the effectiveness of the SWP3 based on the following benchmark monitoring values:

Table 1. Benchmark Parameters

Benchmark Parameter	Benchmark Value	Sampling Frequency	Sample Type
Oil and Grease (*1)	15 mg/L	1/quarter (*2) (*3)	Grab (*4)
Total Suspended Solids (*1)	50 mg/L	1/quarter (*2) (*3)	Grab (*4)
pH	6.0 – 9.0 Standard Units	1/quarter (*2) (*3)	Grab (*4)
Total Iron (*1)	1.3 mg/L	1/quarter (*2) (*3)	Grab (*4)

(*1) All analytical results for these parameters must be obtained from a laboratory that is accredited based on rules located in 30 TAC § 25.4 (a) or through the National Environmental Laboratory Accreditation Program (NELAP). Analysis must be performed using sufficiently sensitive methods for analysis that comply with the rules located in 40 CFR §§ 136.1(c) and 122.44(i)(1)(iv).

(*2) When discharge occurs. Sampling is required within the first 30 minutes of discharge. If it is not practicable to take the sample, or to complete the sampling, within the first 30 minutes, sampling must be completed within the first hour of discharge. If sampling is not completed within the first 30 minutes of discharge, the reason must be documented and attached to all required reports and records of the sampling activity.

(*3) Sampling must be conducted at least once during each of the following periods. The first sample must be collected during the first full quarter that a stormwater discharge occurs from a concrete batch plant authorized under this general permit.

January through March

April through June

July through September

October through December

For projects lasting less than one full quarter, a minimum of one sample shall be collected, provided that a stormwater discharge occurred at least once following submission of the NOI or following the date that automatic authorization was obtained under Part II.E.2., and prior to terminating coverage.

(*4) A grab sample shall be collected from the stormwater discharge resulting from a storm event that is at least 0.1 inches of measured precipitation that occurs at least 72 hours from the previously measurable storm event. The sample shall be collected downstream of the concrete batch plant, and where the discharge exits any BMPs utilized to handle the runoff from the batch plant, prior to commingling with any other water authorized under this general permit.

2. The permittee must compare the results of sample analyses to the benchmark values above, and must include this comparison in the overall assessment of the SWP3's effectiveness. Analytical results that exceed a benchmark value are not a violation of this permit, as these values are not numeric effluent limitations. Results of analyses are indicators that modifications of the SWP3 should be assessed and may be necessary to protect water quality. The operator must investigate the cause for each exceedance and must document the results of this investigation in the SWP3 by the end of the quarter following the sampling event.

The operator's investigation must identify the following:

- (a) any additional potential sources of pollution, such as spills that might have occurred;
- (b) necessary revisions to good housekeeping measures that are part of the SWP3;
- (c) additional BMPs, including a schedule to install or implement the BMPs; and
- (d) other parts of the SWP3 that may require revisions in order to meet the goal of the benchmark values.

Background concentrations of specific pollutants may also be considered during the investigation. If the operator is able to relate the cause of the exceedance to background concentrations, then subsequent exceedances of benchmark values for that pollutant may be resolved by referencing earlier findings in the SWP3. Background concentrations may be identified by laboratory analyses of samples of stormwater run-on to the permitted facility, by laboratory analyses of samples of stormwater run-off from adjacent non-industrial areas, or by identifying the pollutant is a naturally occurring material in soils at the site.

Section B. Best Management Practices (BMPs) and SWP3 Requirements

Minimum SWP3 Requirements – The following are required in addition to other SWP3 requirements listed in this general permit, which include, but are not limited to the applicable requirements located in Part III.F.8. of this general permit, as follows:

1. Description of Potential Pollutant Sources – The SWP3 must provide a description of potential sources (activities and materials) that can cause, have a reasonable potential to cause or contribute to a violation of water quality standards or have been found to cause, or contribute to, the loss of a designated use of surface water in the state in stormwater discharges associated with concrete batch plants authorized under this permit. The SWP3 must describe the implementation of practices that will be used to minimize to the extent practicable the discharge of pollutants in stormwater discharges associated with industrial activity and non-stormwater discharges (described in Part II.A.3. of this general permit), in compliance with the terms and conditions of this general permit, including the protection of water quality, and must ensure the implementation of these practices.

The following must be developed, at a minimum, in support of developing this description:

- (a) Drainage – The site map must include the following information:
 - i. the location of all outfalls for stormwater discharges associated with concrete batch plants that are authorized under this permit;
 - ii. a depiction of the drainage area and the direction of flow to the outfall(s);
 - iii. structural controls used within the drainage area(s);

- iv. the locations of the following areas associated with concrete batch plants that are exposed to precipitation: vehicle and equipment maintenance activities (including fueling, repair, and storage areas for vehicles and equipment scheduled for maintenance); areas used for the treatment, storage, or disposal of wastes; liquid storage tanks; material processing and storage areas; and loading and unloading areas; and
 - v. the locations of the following: any bag house or other dust control device(s); recycle/sedimentation pond, clarifier or other device used for the treatment of facility wastewater (including the areas that drain to the treatment device); areas with significant materials; and areas where major spills or leaks have occurred.
- (b) Inventory of Exposed Materials – A list of materials handled at the concrete batch plant that may be exposed to stormwater and precipitation and that have a potential to affect the quality of stormwater discharges associated with concrete batch plants that are authorized under this general permit.
- (c) Spills and Leaks – A list of significant spills and leaks of toxic or hazardous pollutants that occurred in areas exposed to stormwater and precipitation and that drain to stormwater outfalls associated with concrete batch plants authorized under this general permit must be developed, maintained, and updated as needed.
- (d) Sampling Data – A summary of existing stormwater discharge sampling data must be maintained, if available.
2. Measures and Controls – The SWP3 must include a description of management controls to regulate pollutants identified in the SWP3’s “Description of Potential Pollutant Sources” from Part V.B.1. of this permit, and a schedule for implementation of the measures and controls. This must include, at a minimum:
- (a) Good Housekeeping – Good housekeeping measures must be developed and implemented in the area(s) associated with concrete batch plants.
 - i. Operators must prevent or minimize the discharge of spilled cement, aggregate (including sand or gravel), settled dust, or other significant materials from paved portions of the site that are exposed to stormwater. Measures used to minimize the presence of these materials may include regular sweeping or other equivalent practices. These practices must be conducted at a frequency that is determined based on consideration of the amount of industrial activity occurring in the area and frequency of precipitation, and shall occur at least once per week when cement or aggregate is being handled or otherwise processed in the area.
 - ii. Operators must prevent the exposure of fine granular solids, such as cement, to stormwater. Where practicable, these materials must be stored in enclosed silos, hoppers or buildings, in covered areas, or under covering.
 - (b) Spill Prevention and Response Procedures – Areas where potential spills that can contribute pollutants to stormwater runoff and precipitation, and the drainage areas from these locations, must be identified in the SWP3. Where appropriate, the SWP3 must specify material handling procedures, storage requirements, and use of equipment. Procedures for cleaning up spills must be identified in the SWP3 and made available to the appropriate personnel.
 - (c) Inspections – Qualified facility personnel (i.e., a person or persons with knowledge of this general permit, the concrete batch plant, and the SWP3 related to the concrete batch plant(s) for the site) must be identified to inspect designated equipment and areas of the facility specified in the SWP3. Personnel conducting these inspections are not required to have signatory authority for inspection reports under 30 TAC § 305.128. Inspections of facilities in operation must be performed

once every seven (7) days. Inspections of facilities that are not in operation must be performed at a minimum of once per month. The current inspection frequency being implemented at the facility must be recorded in the SWP3. The inspection must take place while the facility is in operation and must, at a minimum, include all areas that are exposed to stormwater at the site, including material handling areas, above ground storage tanks, hoppers or silos, dust collection/containment systems, truck wash down and equipment cleaning areas. Follow-up procedures must be used to ensure that appropriate actions are taken in response to the inspections. Records of inspections must be maintained and be made readily available for inspection upon request.

- (d) Employee Training – An employee training program must be developed to educate personnel responsible for implementing any component of the SWP3, or personnel otherwise responsible for stormwater pollution prevention, with the provisions of the SWP3. The frequency of training must be documented in the SWP3, and at a minimum, must consist of one (1) training prior to the initiation of operation of the concrete batch plant.
 - (e) Record Keeping and Internal Reporting Procedures – A description of spills and similar incidents, plus additional information that is obtained regarding the quality and quantity of stormwater discharges, must be included in the SWP3. Inspection and maintenance activities must be documented and records of those inspection and maintenance activities must be incorporated in the SWP3.
 - (f) Management of Runoff – The SWP3 shall contain a narrative consideration for reducing the volume of runoff from concrete batch plants by diverting runoff or otherwise managing runoff, including use of infiltration, detention ponds, retention ponds, or reusing of runoff.
3. Comprehensive Compliance Evaluation – At least once per year, one or more qualified personnel (i.e., a person or persons with knowledge of this general permit, the concrete batch plant, and the SWP3 related to the concrete batch plant(s) for the site) shall conduct a compliance evaluation of the plant. The evaluation must include the following:
- (a) visual examination of all areas draining stormwater associated with regulated concrete batch plants for evidence of, or the potential for, pollutants entering the drainage system. These include, but are not limited to: cleaning areas, material handling areas, above ground storage tanks, hoppers or silos, dust collection/containment systems, and truck wash down and equipment cleaning areas. Measures implemented to reduce pollutants in runoff (including structural controls and implementation of management practices) must be evaluated to determine if they are effective and if they are implemented in accordance with the terms of this permit and with the permittee's SWP3. The operator shall conduct a visual inspection of equipment needed to implement the SWP3, such as spill response equipment.
 - (b) based on the results of the evaluation, the following must be revised as appropriate within two (2) weeks of the evaluation: the description of potential pollutant sources identified in the SWP3 (as required in Part V.B.1., "Description of Potential Pollutant Sources"); and pollution prevention measures and controls identified in the SWP3 (as required in Part V.B.2., "Measures and Controls"). The revisions may include a schedule for implementing the necessary changes.
 - (c) the permittee shall prepare and include in the SWP3 a report summarizing the scope of the evaluation, the personnel making the evaluation, the date(s) of the evaluation, major observations relating to the implementation of the SWP3, and actions taken in response to the findings of the evaluation. The report must identify any incidents of noncompliance. Where the report does not identify incidences of noncompliance, the report must contain a statement that the evaluation did not identify any

incidence(s), and the report must be signed according to 30 TAC § 305.128 (relating to Signatories to Reports).

- (d) the Comprehensive Compliance Evaluation may substitute for one of the required inspections delineated in Part V.B.2.(c) of this general permit.

Section C. Prohibition of Wastewater Discharges

Wastewater discharges associated with concrete production including wastewater disposal by land application are not authorized under this general permit. These wastewater discharges must be authorized under an alternative TCEQ water quality permit or otherwise disposed of in an authorized manner. Discharges of concrete truck wash out at construction sites may be authorized if conducted in accordance with the requirements of Part VI of this general permit.

Part VI. Concrete Truck Wash Out Requirements

This general permit authorizes the land disposal of wash out from concrete trucks at construction sites regulated under this general permit, provided the following requirements are met. Any discharge of concrete production wastewater to surface water in the state must be authorized under a separate TCEQ general permit or individual permit.

- A.** Discharge of concrete truck wash out water to surface water in the state, including discharge to storm sewers, is prohibited by this general permit.
- B.** Concrete truck wash out water shall be disposed in areas at the construction site where structural controls have been established to prevent discharge to surface water in the state, or to areas that have a minimal slope that allow infiltration and filtering of wash out water to prevent discharge to surface water in the state. Structural controls may consist of temporary berms, temporary shallow pits, temporary storage tanks with slow rate release, or other reasonable measures to prevent runoff from the construction site.
- C.** Wash out of concrete trucks during rainfall events shall be minimized. The discharge of concrete truck wash out water is prohibited at all times, and the operator shall insure that its BMPs are sufficient to prevent the discharge of concrete truck wash out as the result of rainfall or stormwater runoff.
- D.** The disposal of wash out water from concrete trucks, made under authorization of this general permit must not cause or contribute to groundwater contamination.
- E.** If a SWP3 is required to be implemented, the SWP3 shall include concrete wash out areas on the associated site map.

Part VII. Retention of Records

The permittee must retain the following records for a minimum period of three (3) years from the date that a NOT is submitted as required in Part II.F.1. and 2. of this permit. For activities in which an NOT is not required, records shall be retained for a minimum period of three (3) years from the date that the operator terminates coverage under Section II.F.3. of this permit. Records include:

- A.** a copy of the SWP3;
- B.** all reports and actions required by this permit, including a copy of the TCEQ construction site notice;
- C.** all data used to complete the NOI, if an NOI is required for coverage under this general permit; and
- D.** all records of submittal of forms submitted to the operator of any MS4 receiving the discharge and to the secondary operator of a large construction site, if applicable.

Part VIII. Standard Permit Conditions

- A.** The permittee has a duty to comply with all permit conditions. Failure to comply with any permit condition is a violation of the permit and statutes under which it was issued (CWA and TWC), and is grounds for enforcement action, for terminating, revoking and reissuance, or modification, or denying coverage under this general permit, or for requiring a discharger to apply for and obtain an individual TPDES permit, based on rules located in TWC § 23.086, 30 TAC § 305.66, and 40 CFR § 122.41 (a).
- B.** Authorization under this general permit may be modified, suspended, revoked and reissued, terminated or otherwise suspended for cause, based on rules located in TWC § 23.086, 30 TAC § 305.66, and 40 CFR § 122.41(f). Filing a notice of planned changes or anticipated non-compliance by the permittee does not stay any permit condition. The permittee must furnish to the executive director, upon request and within a reasonable time, any information necessary for the executive director to determine whether cause exists for modifying, revoking and reissuing, terminating or, otherwise suspending authorization under this permit, based on rules located in TWC § 23.086, 30 TAC § 305.66, and 40 CFR § 122.41 (h). Additionally, the permittee must provide to the executive director, upon request, copies of all records that the permittee is required to maintain as a condition of this general permit.
- C.** It is not a defense for a discharger in an enforcement action that it would have been necessary to halt or reduce the permitted activity to maintain compliance with the permit conditions.
- D.** Inspection and entry shall be allowed under TWC Chapters 26-28, Texas Health and Safety Code §§ 361.032-361.033 and 361.037, and 40 CFR § 122.41(i). The statement in TWC § 26.014 that commission entry of a facility shall occur according to an establishment's rules and regulations concerning safety, internal security, and fire protection is not grounds for denial or restriction of entry to any part of the facility or site, but merely describes the commission's duty to observe appropriate rules and regulations during an inspection.
- E.** The discharger is subject to administrative, civil, and criminal penalties, as applicable, under TWC Chapter 7 for violations including but not limited to the following:
1. negligently or knowingly violating the federal CWA §§ 301, 302, 306, 307, 308, 318, or 405, or any condition or limitation implementing any sections in a permit issued under CWA § 402, or any requirement imposed in a pretreatment program approved under CWA §§ 402(a)(3) or 402(b)(8);
 2. knowingly making any false statement, representation, or certification in any record or other document submitted or required to be maintained under a permit, including monitoring reports or reports of compliance or noncompliance; and
 3. knowingly violating CWA §303 and placing another person in imminent danger of death or serious bodily injury.
- F.** All reports and other information requested by the executive director must be signed by the person and in the manner required by 30 TAC § 305.128 (relating to Signatories to Reports).
- G.** Authorization under this general permit does not convey property or water rights of any sort and does not grant any exclusive privilege.
- H.** The permittee shall take all reasonable steps to minimize or prevent any discharge in violation of this permit that has a reasonable likelihood of adversely affecting human health or the environment.

- I.** The permittee shall at all times properly operate and maintain all facilities and systems of treatment and control (and related appurtenances) that are installed or used by the permittee to achieve compliance with the conditions of this permit. Proper operation and maintenance also includes adequate laboratory controls and appropriate quality assurance procedures. This provision requires the operation of back-up or auxiliary facilities or similar systems that are installed by a permittee only when the operation is necessary to achieve compliance with the conditions of the permit.
- J.** The permittee shall comply with the monitoring and reporting requirements in 40 CFR § 122.41(j) and (l), as applicable.
- K.** Analysis must be performed using sufficiently sensitive methods for analysis that comply with the rules located in 40 CFR §§ 136.1(c) and 122.44(i)(1)(iv).

Part IX. Fees

- A.** A fee of must be submitted along with the NOI:
 - 1. \$225 if submitting an NOI electronically, or
 - 2. \$325 if submitting a paper NOI.
- B.** Fees are due upon submission of the NOI. An NOI will not be declared administratively complete unless the associated fee has been paid in full.
- C.** No separate annual fees will be assessed for this general permit. The Water Quality Annual Fee has been incorporated into the NOI fees as described above.

Appendix A: Automatic Authorization

Periods of Low Erosion Potential by County – Eligible Date Ranges

Andrews: Nov. 15 - Apr. 30	Foard: Dec. 15 - Feb. 14
Archer: Dec. 15 - Feb. 14	Gaines: Nov. 15 - Apr. 30
Armstrong: Nov. 15 - Apr. 30	Garza: Nov. 15 - Apr. 30
Bailey: Nov. 1 - Apr. 30, or Nov. 15 - May 14	Glasscock: Nov. 15 - Apr. 30
Baylor: Dec. 15 - Feb. 14	Hale: Nov. 15 - Apr. 30
Borden: Nov. 15 - Apr. 30	Hall: Feb. 1 - Mar. 30
Brewster: Nov. 15 - Apr. 30	Hansford: Nov. 15 - Apr. 30
Briscoe: Nov. 15 - Apr. 30	Hardeman: Dec. 15 - Feb. 14
Brown: Dec. 15 - Feb. 14	Hartley: Nov. 15 - Apr. 30
Callahan: Dec. 15 - Feb. 14	Haskell: Dec. 15 - Feb. 14
Carson: Nov. 15 - Apr. 30	Hockley: Nov. 1 - Apr. 14, or Nov. 15 - Apr. 30
Castro: Nov. 15 - Apr. 30	Howard: Nov. 15 - Apr. 30
Childress: Dec. 15 - Feb. 14	Hudspeth: Nov. 1 - May 14
Cochran: Nov. 1 - Apr. 30, or Nov. 15 - May 14	Hutchinson: Nov. 15 - Apr. 30
Coke: Dec. 15 - Feb. 14	Irion: Dec. 15 - Feb. 14
Coleman: Dec. 15 - Feb. 14	Jeff Davis: Nov. 1 - Apr. 30 or Nov. 15 - May 14
Collingsworth: Jan. 1 - Mar. 30, or Dec. 1 - Feb. 28	Jones: Dec. 15 - Feb. 14
Concho: Dec. 15 - Feb. 14	Kent: Nov. 15 - Jan. 14 or Feb. 1 - Mar. 30
Cottle: Dec. 15 - Feb. 14	Kerr: Dec. 15 - Feb. 14
Crane: Nov. 15 - Apr. 30	Kimble: Dec. 15 - Feb. 14
Crockett: Nov. 15 - Jan. 14, or Feb. 1 - Mar. 30	King: Dec. 15 - Feb. 14
Crosby: Nov. 15 - Apr. 30	Kinney: Dec. 15 - Feb. 14
Culberson: Nov. 1 - May 14	Knox: Dec. 15 - Feb. 14
Dallam: Nov. 1 - Apr. 14, or Nov. 15 - Apr. 30	Lamb: Nov. 1 - Apr. 14, or Nov. 15 - Apr. 30
Dawson: Nov. 15 - Apr. 30	Loving: Nov. 1 - Apr. 30, or Nov. 15 - May 14
Deaf Smith: Nov. 15 - Apr. 30	Lubbock: Nov. 15 - Apr. 30
Dickens: Nov. 15 - Jan. 14, or Feb. 1 - Mar. 30	Lynn: Nov. 15 - Apr. 30
Dimmit: Dec. 15 - Feb. 14	Martin: Nov. 15 - Apr. 30
Donley: Jan. 1 - Mar. 30, or Dec. 1 - Feb. 28	Mason: Dec. 15 - Feb. 14
Eastland: Dec. 15 - Feb. 14	Maverick: Dec. 15 - Feb. 14
Ector: Nov. 15 - Apr. 30	McCulloch: Dec. 15 - Feb. 14
Edwards: Dec. 15 - Feb. 14	Menard: Dec. 15 - Feb. 14
El Paso: Jan. 1 - Jul. 14, or May 15 - Jul. 31, or Jun. 1 - Aug. 14, or Jun. 15 - Sept. 14, or Jul. 1 - Oct. 14, or Jul. 15 - Oct. 31, or Aug. 1 - Apr. 30, or Aug. 15 - May 14, or Sept. 1 - May 30, or Oct. 1 - Jun. 14, or Nov. 1 - Jun. 30, or Nov. 15 - Jul. 14	Midland: Nov. 15 - Apr. 30
Fisher: Dec. 15 - Feb. 14	Mitchell: Nov. 15 - Apr. 30
Floyd: Nov. 15 - Apr. 30	Moore: Nov. 15 - Apr. 30
	Motley: Nov. 15 - Jan. 14, or Feb. 1 - Mar. 30
	Nolan: Dec. 15 - Feb. 14
	Oldham: Nov. 15 - Apr. 30

Construction General Permit

TPDES General Permit No. TXR150000
Appendix A

Parmer: Nov. 1 - Apr. 14, or Nov. 15 - Apr. 30
Pecos: Nov. 15 - Apr. 30
Potter: Nov. 15 - Apr. 30
Presidio: Nov. 1 - Apr. 30, or Nov. 15 - May 14
Randall: Nov. 15 - Apr. 30
Reagan: Nov. 15 - Apr. 30
Real: Dec. 15 - Feb. 14
Reeves: Nov. 1 - Apr. 30, or Nov. 15 - May 14
Runnels: Dec. 15 - Feb. 14
Schleicher: Dec. 15 - Feb. 14
Scurry: Nov. 15 - Apr. 30
Shackelford: Dec. 15 - Feb. 14
Sherman: Nov. 15 - Apr. 30
Stephens: Dec. 15 - Feb. 14
Sterling: Nov. 15 - Apr. 30
Stonewall: Dec. 15 - Feb. 14
Sutton: Dec. 15 - Feb. 14

Swisher: Nov. 15 - Apr. 30
Taylor: Dec. 15 - Feb. 14
Terrell: Nov. 15 - Apr. 30
Terry: Nov. 15 - Apr. 30
Throckmorton: Dec. 15 - Feb. 14
Tom Green: Dec. 15 - Feb. 14
Upton: Nov. 15 - Apr. 30
Uvalde: Dec. 15 - Feb. 14
Val Verde: Nov. 15 - Jan. 14, or Feb. 1 - Mar. 30
Ward: Nov. 1 - Apr. 14, or Nov. 15 - Apr. 30
Wichita: Dec. 15 - Feb. 14
Wilbarger: Dec. 15 - Feb. 14
Winkler: Nov. 1 - Apr. 30, or Nov. 15 - May 14
Yoakum: Nov. 1 - Apr. 30, or Nov. 15 - May 14
Young: Dec. 15 - Feb. 14
Wheeler: Jan. 1 - Mar. 30, or Dec. 1 - Feb. 28
Zavala: Dec. 15 - Feb. 14

Appendix B: Storm Erosivity (EI) Zones in Texas

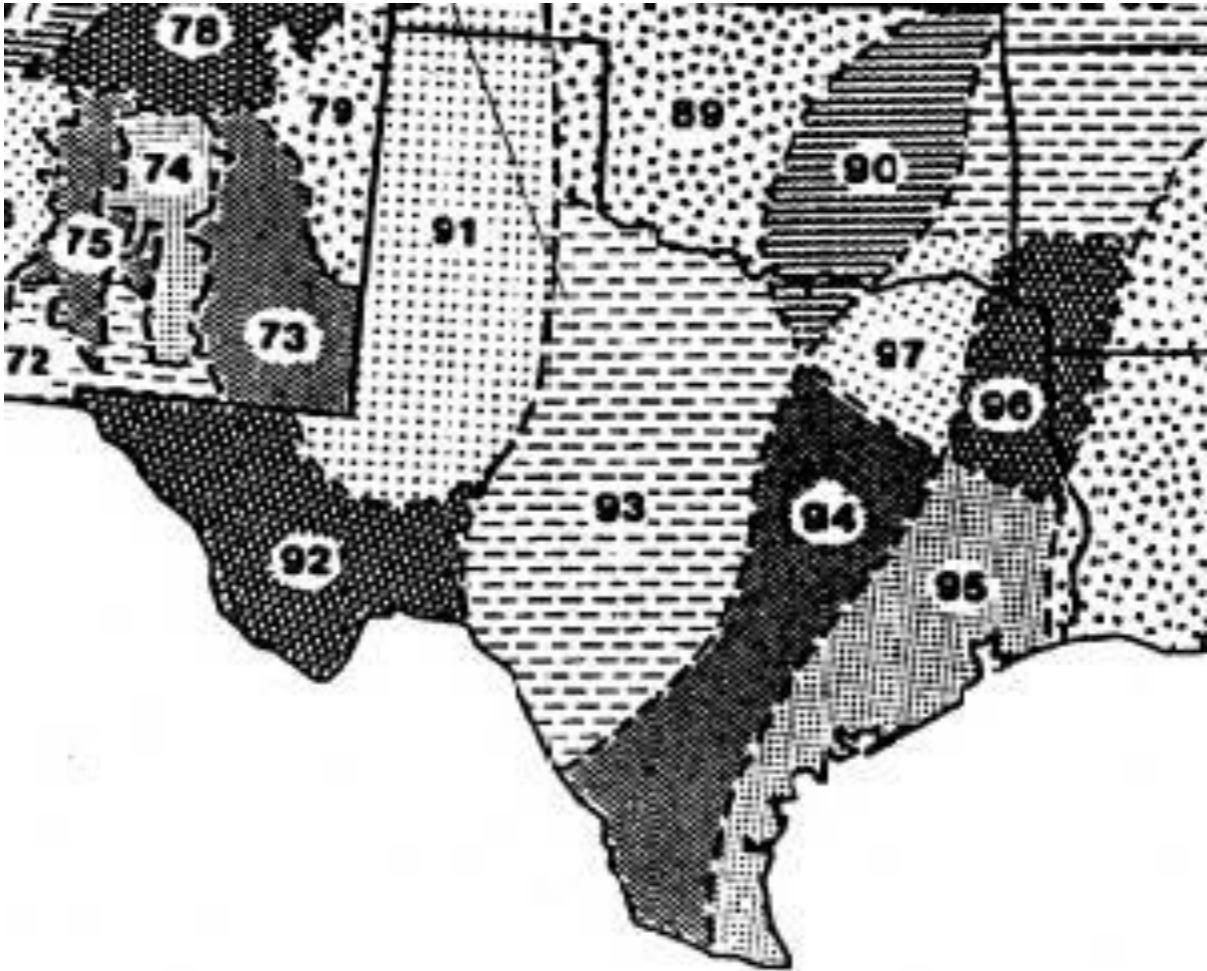

Figure B. EI Distribution Zones

Adapted from Chapter 2 of USDA Agriculture Handbook 703: "Predicting Soil Erosion by Water: A Guide to Conservation Planning With the Revised Universal Soil Loss Equation (RUSLE)," U.S. Department of Agriculture, Agricultural Research Service

Appendix C: Isoerodent Map

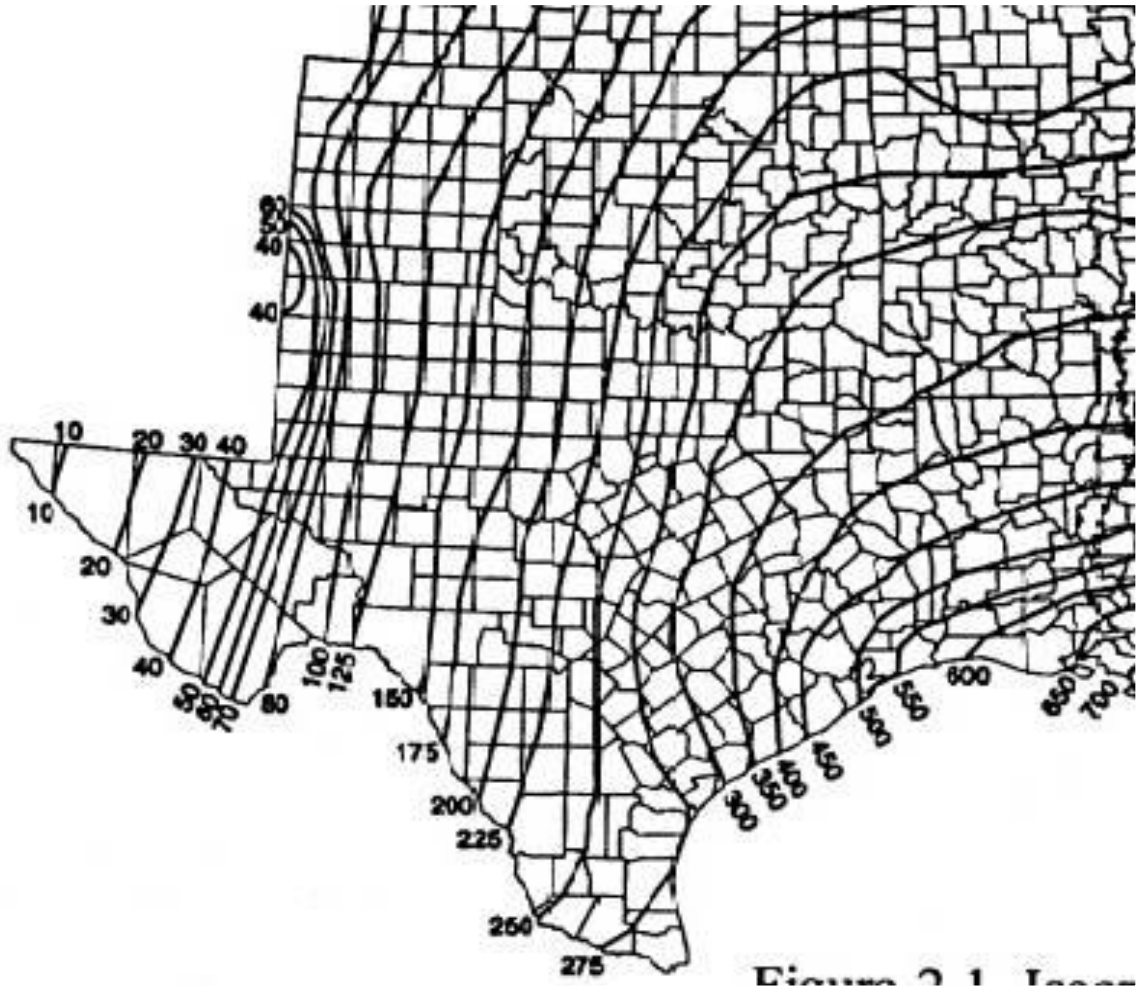

Figure C. Isoerodent Map of Texas. Units are hundreds ft*tonf*in/(ac*h*yr)⁻¹

Adapted from Chapter 2 of USDA Agriculture Handbook 703: "Predicting Soil Erosion by Water: A Guide to Conservation Planning With the Revised Universal Soil Loss Equation (RUSLE)," U.S. Department of Agriculture, Agricultural Research Service

Appendix D: Erosivity Indices for EI Zones in Texas

Table D. EI as percentage of average annual computed selected geographic areas (EI number) by date period (month/day).

Date Periods* (Month/Day)

EI #	1/1	1/16	1/31	2/15	3/1	3/16	3/31	4/15	4/30	5/15	5/30	6/14	6/29	7/14	7/29	8/13	8/28	9/12	9/27	10/12	10/27	11/11	11/26	12/11	12/31
89	0	1	1	2	3	4	7	2	8	27	38	48	55	62	69	76	83	90	94	97	98	99	100	100	100
90	0	1	2	3	4	6	8	13	21	29	37	46	54	60	65	69	74	81	87	92	95	97	98	99	100
91	0	0	0	0	1	1	1	2	6	16	29	39	46	53	60	67	74	81	88	95	99	99	100	100	100
92	0	0	0	0	1	1	1	2	6	16	29	39	46	53	60	67	74	81	88	95	99	99	100	100	100
93	0	1	1	2	3	4	6	8	13	25	40	49	56	62	67	72	76	80	85	91	97	98	99	99	100
94	0	1	2	4	6	8	10	15	21	29	38	47	53	57	61	65	70	76	83	88	91	94	96	98	100
95	0	1	3	5	7	9	11	14	18	27	35	41	46	51	57	62	68	73	79	84	89	93	96	98	100
96	0	2	4	6	9	12	17	23	30	37	43	49	54	58	62	66	70	74	78	82	86	90	94	97	100
97	0	1	3	5	7	10	14	20	28	37	48	56	61	64	68	72	77	81	86	89	92	95	98	99	100
106	0	3	6	9	13	17	21	27	33	38	44	49	55	61	67	71	75	78	81	84	86	90	94	97	100

*Each period begins on the date listed in the table above and lasts until the day before the following period. The final period begins on December 11 and ends on December 31.

Table adapted from Chapter 2 of USDA Agriculture Handbook 703: "Predicting Soil Erosion by Water: A Guide to Conservation Planning With the Revised Universal Soil Loss Equation (RUSLE)," U.S. Department of Agriculture, Agricultural Research Service.

APPENDIX H

SITE NOTICE, NOTICE OF INTENT, NOTICE OF
CHANGE AND NOTICE OF TERMINATION
FORMS

Operator Notes

Construction Site Notice

The construction site notice located in Appendix H should be posted along with a signed copy of the Notice of Intent is applicable. The site notice must be located where it is safely and readily available for viewing by the general public, local, state, and federal authorities prior to commencing construction.

Notice of Intent (NOI)

The TPDES General Permit TXR 150000 requires that a NOI be submitted electronically before construction activities begin. The NOI is essentially an application and contains items such as important information about your site, including site location, owner information, operator (general contractor) information, receiving water(s), and a brief description of the project.

TCEQ has developed a form to be used by industrial facilities and construction activities when they submit NOIs. This form indicates all the information that you are required to provide and must be used in order for the NOI to be processed correctly.

Primary Operators

Please note that both Owners and Contractors can meet the definition of being a “primary operator.”

Primary operators must submit a NOI at least seven days prior to commencing construction activities, or if utilizing electronic submittal, prior to commencing construction activities.

If an additional primary operator is added after the initial NOI is submitted, the new primary operator must submit an electronic NOI prior to assuming operational control.

If the primary operator changes after the initial NOI is submitted, the new primary operator must submit an electronic NOI at least ten days before assuming operational control.

All primary operators must post a copy of the signed NOI at the construction site in allocation where it is readily available for viewing by the general public, local, state, and federal authorities prior to commencing construction activities. A copy of the signed NOI must be submitted to the operator of any MS4 receiving the discharge and to any secondary operator, at least seven days prior to commencing construction activities. A list of the MS4 operators receiving a copy of the NOI is located in Appendix H.

Secondary Operators

Secondary operators are not required to submit a NOI, provided that another operator(s) at the site has submitted a NOI, or is required to submit a NOI and the secondary operator has provided notification to the operator(s) of the need to obtain coverage under the permit. Please refer to the general permit for more information.

NOI Fees

Please note the fees associated with NOI submission:

- \$325 if submitting a paper NOI, or
- \$225 if submitting an electronic NOI.

No separate annual fees will be assessed. The Water Quality Annual fee has been incorporated into the NOI fees.

It is anticipated that there will be projects where more than one entity (e.g., the owner, developer, or general contractor) will need to submit an NOI so that the requirements for an operator are met. In this case, those persons will share the Storm Water Pollution Plan, and the submittal of the NOI and the TPDES Permit Number will need to be recorded in the NOI log located in Appendix F.

Please refer to the general permit and NOI form instructions for more information.



LARGE CONSTRUCTION SITE NOTICE

FOR THE
Texas Commission on Environmental Quality (TCEQ)
Stormwater Program
TPDES GENERAL PERMIT TXR150000

“PRIMARY OPERATOR” NOTICE

This notice applies to construction sites operating under Part I.I.E.3. of the TPDES General Permit Number TXR150000 for discharges of stormwater runoff from construction sites equal to or greater than five acres, including the larger common plan of development. The information on this notice is required in Part III.D.2. of the general permit. Additional information regarding the TCEQ stormwater permit program may be found on the internet at:

<https://www.tceq.texas.gov/permitting/stormwater/construction>

Site-Specific TPDES Authorization Number:	
Operator Name:	
Contact Name and Phone Number:	
Project Description: <i>Physical address or description of the site's location, and estimated start date and projected end date, or date that disturbed soils will be stabilized.</i>	
Location of Stormwater Pollution Prevention Plan:	



LARGE CONSTRUCTION SITE NOTICE

FOR THE
Texas Commission on Environmental Quality (TCEQ)
Storm Water Program
TPDES GENERAL PERMIT TXR150000
“SECONDARY OPERATOR” NOTICE

This notice applies to secondary operators of construction sites operating under Part II.E.3. of the TPDES General Permit Number TXR150000 for discharges of storm water runoff from construction sites equal to or greater than five acres, including the larger common plan of development. The information on this notice is required in Part III.D.2. of the general permit. Additional information regarding the TCEQ storm water permit program may be found on the internet at:

http://www.tceq.state.tx.us/nav/permits/sw_permits.html

Site-Specific TPDES Authorization Number:	TXR150000
Operator Name:	
Contact Name and Phone Number:	
Project Description: <i>Physical address or description of the site's location, and estimated start date and projected end date, or date that disturbed soils will be stabilized.</i>	
Location of Storm Water Pollution Prevention Plan (SWP3):	

For Large Construction Activities Authorized Under Part II.E.3. (Obtaining Authorization to Discharge) the following certification must be completed:

I _____ (Typed or Printed Name Person Completing This Certification) certify under penalty of law that I have read and understand the eligibility requirements for claiming an authorization under Part II.E.3. of TPDES General Permit TXR150000 and agree to comply with the terms of this permit. A storm water pollution prevention plan has been developed and will be implemented prior to construction, according to permit requirements. A copy of this signed notice is supplied to the operator of the MS4 if discharges enter an MS4. I am aware there are significant penalties for providing false information or for conducting unauthorized discharges, including the possibility of fine and imprisonment for knowing violations.

Signature and Title _____ Date _____

Date Notice Removed

MS4 operator notified per Part II.F.3.



Notice of Change (NOC) to an Authorization for Stormwater Discharges Associated With Construction Activity under TPDES General Permit TXR150000

IMPORTANT – Please read the following information and [INSTRUCTIONS](#) before filling out this form

ePERMITS: Sign up now for online NOC: <https://www3.tceq.texas.gov/steers/index.cfm>

This form will be returned for any of the following reasons:

- 1) The permit number is not provided, is invalid, or is no longer active,
- 2) Wet ink signature of person meeting signatory requirements is not provided,
- 3) The current permittee is not the applicant, and;
- 4) A requested change in operator name is not a legal name change.

This form cannot be used for a change in operator. Refer to your general permit for Information.

What is the permit number of the authorization to be changed?

TXR15 _____ or TXRCW _____

1) APPLICANT INFORMATION

a) What is the full Legal Name of the current operator as on the authorization?

b) What is the Customer Number (CN) assigned to this operator? You may search for your CN at: <http://www.tceq.texas.gov/goto/cr-customer>

CN _____

c) What is the name and title of the person signing the application? The person must be an executive official meeting signatory requirements in TAC §305.44(a).

Prefix (Mr. Ms Miss): _____

First/Last Name: _____ Suffix: _____

Title: _____ Credential: _____

d) What is the Regulated Entity Reference Number (RN) assigned to this site?

RN _____

2) APPLICATION CONTACT

If TCEQ needs additional information regarding this application, who should be contacted?

Prefix (Mr. Ms. Miss): _____
First/Last Name: _____ Suffix: _____ Title: _____
Credential: _____
Organization Name: _____ Phone Number: _____ Ext: _____ Fax Number: _____ E-mail: _____
Mailing Address: _____ Internal Routing (Mail Code, Etc.): _____ City: _____
State: _____ ZIP Code: _____
Mailing Information if outside USA:
Territory: _____ Country Code: _____ Postal Code: _____

3) REQUESTED CHANGE TO PERMITTED INFORMATION

What information has changed or needs to be corrected? Check one or more of the following options and enter the new information below.

Operator legal name change with Texas Secretary of State (TX SOS).

Go to sections a) and b) as applicable.

Note: Permits are not transferable. If a change in entity has occurred, this NOC will not be processed.

Address and contact information for the Operator. Fill out section b).

Site Information (Regulated Entity). Fill out section c).

Note: Permits under a general permit are site specific. If a change in site location has occurred, this NOC will not be processed.

General characteristics relating to the regulated activity. Fill out section d).

a) Operator Legal Name Change

1. What is the NEW active Legal Name with TX SOS or on other legal document?

New Legal Name: _____

2. What is the TX SOS Filing Number for us to confirm this official name change?

This is only applicable to Limited Partnerships or Corporations.

TX SOS Filing number: _____

b) Address and Contact Information for the Operator

Verify mailing addresses with USPS:

<https://tools.usps.com/go/ZipLookupAction!input.action>

Prefix (Mr. Ms. Miss): _____
First/Last Name: _____ Suffix: _____ Title: _____
Credential: _____ Organization Name: _____
Phone Number: _____ Ext: _____ Fax Number: _____ E-mail: _____
Mailing Address: _____

Internal Routing (Mail Code, Etc.): _____ City:
State: _____ ZIP Code: _____ Mailing Information if outside USA:
Territory: _____ Country Code: _____ Postal Code: _____

c) Regulated Entity (Site) Information Correction

1. Is this a change to the location of the permitted activity?
Yes – This NOC will not be processed since the authorizations are site specific.

No – Continue with NOC form.

2. Corrected Name of Project or Site :

3. Updated Physical Address (new 911 address):
Street Number: _____ Street Name: _____
City: _____ State: _____ ZIP Code: _____

4. Corrected location access description, if no physical address (street number/street name):

5. Corrected Latitude: _____ N

6. Corrected Longitude: _____ W

7. Corrected County (Counties if >1):

d) Change in General Characteristics Provided on Original Form. Identify the specific change and provide the updates information. If an attachment is needed, please reference it below:

4) OPERATOR CERTIFICATION

I, _____
Typed or printed name *Title*

certify under penalty of law that this document and all attachments were prepared under my direction or supervision in accordance with a system designed to assure that qualified personnel properly gather and evaluate the information submitted. Based on my inquiry of the person or persons who manage the system, or those persons directly responsible for gathering the information, the information submitted is, to the best of my knowledge and belief, true, accurate, and complete. I am aware there are significant penalties for submitting false information, including the possibility of fine and imprisonment for knowing violations.

I further certify that I am authorized under 30 Texas Administrative Code §305.44 to sign and submit this document, and can provide documentation in proof of such authorization upon request.

Signature: _____ Date: _____
(Use blue ink)

Notice of Change (NOC) for Stormwater Discharges Associated with Construction Activity under TPDES General Permit TXR150000

General Information and Instructions

GENERAL INFORMATION

Where to Send the NOC:

BY REGULAR U.S. MAIL

Texas Commission on Environmental Quality
Stormwater Processing Center (MC-228)
P.O. Box 13087
Austin, Texas 78711-3087

BY OVERNIGHT/EXPRESS MAIL

Texas Commission on Environmental Quality
Stormwater Processing Center (MC-228)
12100 Park 35 Circle
Austin, TX 78753

TCEQ Contact list:

Application – status and form questions:	512/245-0130, swpermit@tceq.texas.gov
Technical questions:	512/239-4671, swgp@tceq.texas.gov
Environmental Law Division:	512/239-0600
Records Management - obtain copies of forms:	512/239-0900
Reports from databases (as available):	512/239-DATA (3282)
Cashier's office:	512/239-0357 or 512/239-0187

NOC Process:

1. Administrative Review: The form will be reviewed to ensure the request is from the permittee (operator) on the authorization, the permit is active and initial coverage was acknowledged. Each item on the form will be reviewed for a complete response. In addition, the operator's legal name change must be verified with Texas Secretary of State (if applicable). The address(s) on the form must be verified with the US Postal Service (USPS) as an address receiving regular mail delivery. Never give an overnight/express mailing address. If an item is incomplete or not verifiable, the operator may be notified by letter, phone call or email. In some instances as noted at the beginning of the form, the request may simply be returned.

2. NOC Confirmation: An updated Acknowledgment Certificate will be mailed to the operator only if the NOC is to change information provided on the acknowledgment certificate. The original coverage effective date will not change.

General Permit (Your Permit) and Forms

You may view and print your general permit on the TCEQ web site <http://www.tceq.texas.gov>. Search using key word TXR150000. General Permit Forms (NOI, NOT, and NOC) and instructions are available on the TCEQ web site <http://www.tceq.texas.gov>.

Change in Operator

An authorization under the general permit is not transferable. If the operator of the regulated entity changes, the present permittee must submit a NOT and the new operator must submit a NOI. The NOI must be submitted not later than 10 days prior to the change in Operator status. Note that the NOT is effective on the postmarked date. It may be necessary to not terminate the existing permit until coverage by the new entity is confirmed.

TCEQ Central Registry Core Data Form

The Core Data Form has been incorporated into this form. Do not send a Core Data Form to TCEQ. You can find the information on the Central Registry web site at <http://www15.tceq.texas.gov/crpub/>.

You can search by the Regulated Entity (RN), Customer Number (CN) or Name (Permittee), or by your permit number under the search field labeled *Additional ID*.

The Customer (Permittee) is responsible for providing consistent information to the TCEQ, and for updating all CN and RN data for all associated authorizations as changes occur. For General Permits, a Notice of Change form must be submitted to the program area for approval to update the CN and RN data in central registry.

INSTRUCTIONS FOR FILLING OUT THE NOC FORM

1) APPLICANT INFORMATION

a) Legal Name. Provide the current legal name of the permittee, as on the permit.

b) Customer Number (CN). TCEQ's Central Registry will assign each customer a number that begins with CN, followed by nine digits. You may search for your CN at: <http://www.tceq.texas.gov/goto/cr-customer>.

If the name(s) provided do not match the current permittee name(s), this form will be returned. It is the responsibility of the permittee(s) to comply with the general permit.

Note: If a change is being made to the CN and the CN has other TCEQ authorization types, it is the entity's responsibility to update those authorizations at the same time. If an authorization has been cancelled or terminated, the name cannot be changed on the permit. Because of this, a new CN may be issued for the new name.

c) Person Signing this Application. Provide the name and title of the person signing the application. The person must be an executive official meeting signatory requirements in TAC §305.44.

d) Regulated Entity Reference Number (RN). This is a number issued by TCEQ's Central Registry to sites (a location where a regulated activity occurs) regulated by TCEQ. This is not a permit number, registration number, or license number. Search for your RN: <http://www.tceq.texas.gov/goto/cr-searchrn>.

If the site has changed or the information provided indicates a new location, this form will be returned. It is the responsibility of the permittee to comply with the general permit.

2) APPLICATION CONTACT

Provide the name, title and contact information of the person that TCEQ can contact for additional information regarding this application.

3) REQUESTED CHANGE TO PERMITTED INFORMATION

Check one or more of the available options indicating the information in the form that is to be updated. Provide the updated information in 3 a) for Legal Name Change, 3 b) for Address and Contact Information Change, 3 c) for Regulated Entity Site Information Change, or 3 d) for General Characteristics Change, as applicable.

a) Legal Name Change. Provide the new legal name. If the entity is a Limited Partnership or Corporation, the name change must be verifiable with Texas Secretary of State. The TX SOS filing number must be provided to verify only a name change occurred. You may contact the SOS at 512/463-5555, for more information related to filing in Texas. If filed in the county where doing business, provide a copy of the legal documents showing the legal name change.

Legal name changes of a Corporation and Limited Partnership will be verified with Texas Secretary of State. If the entity is filed as a new entity with a new filing number, then the change cannot be made through a NOC. The permits are not transferable. If the operator changes, the old entity must terminate their permit and the new entity must submit a form for a new permit.

b) Address and Contact Information Change. Indicate the type of address and contact information that has changed from the original NOI or last NOC submitted to TCEQ.

Verify mailing addresses with USPS <https://tools.usps.com/go/ZipLookupAction!input.action> for regular mail delivery (not overnight express mail). If you find that the address is not verifiable please indicate the address is used by the USPS for regular mail delivery. Failure to provide a valid mailing address will delay or prohibit us from updating the permit.

Please note that address updates relating to a general permit authorization can ONLY be made through a Notice of Change. Address changes submitted through any other form cannot be processed.

c) Regulated Entity Site Information Change. The NOC form is only for use to update or correct information submitted on the original application or last NOC for the authorization. The authorization under a general permit is site specific. If this change is related to a new location, a Notice of Change will not be processed.

Provide the updated site name, updated site addresses, corrected latitude and longitude, and/or corrected county, as applicable to your NOC request. A new physical address for an existing location is usually the result of a newly assigned 911 address for emergencies.

If providing a corrected latitude and longitude, enter the latitude and longitude of the site in degrees, minutes, and seconds or decimal form. For help obtaining the latitude and longitude, go to <http://www.tceq.texas.gov/gis/sqmaview.html> or <http://msrmaps.com/advfind.aspx>.

d) Change in General Characteristics Provided on Original Form

Describe any other change that is not addressed through any question in this section of the application.

4) OPERATOR CERTIFICATION

The certification must bear an original signature of a person meeting the signatory requirements specified under 30 Texas Administrative Code (TAC) §305.44.

IF YOU ARE A CORPORATION:

The regulation that controls who may sign an NOI or similar form is 30 Texas Administrative Code §305.44(a) (see below). According to this code provision, any corporate representative may sign an NOI or similar form so long as the authority to sign such a document has been delegated to that person in accordance with corporate procedures. By signing the NOI or similar form, you are certifying that such authority has been delegated to you. The TCEQ may request documentation evidencing such authority.

IF YOU ARE A MUNICIPALITY OR OTHER GOVERNMENT ENTITY:

The regulation that controls who may sign an NOI or similar form is 30 Texas Administrative Code §305.44(a) (see below). According to this code provision, only a ranking elected official or principal executive officer may sign an NOI or similar form. Persons such as the City Mayor or County Commissioner will be considered ranking elected officials. In order to identify the principal executive officer of your government entity, it may be beneficial to consult your city charter, county or city ordinances, or the Texas statute(s) under which your government entity was formed. An NOI or similar document that is signed by a government official who is not a ranking elected official or principal executive officer does not conform to §305.44(a)(3). The signatory requirement may not be delegated to a government representative other than those identified in the regulation. By signing the NOI or similar form, you are certifying that you are either a ranking elected official or principal executive officer as required by the administrative code. Documentation demonstrating your position as a ranking elected official or principal executive officer may be requested by the TCEQ.

If you have any questions or need additional information concerning the signatory requirements discussed above, please contact the Texas Commission on Environmental Quality's Environmental Law Division at 512/239-0600.

30 Texas Administrative Code

§305.44. Signatories to Applications

(a) All applications shall be signed as follows.

(1) For a corporation, the application shall be signed by a responsible corporate officer. For purposes of this paragraph, a responsible corporate officer means a president, secretary, treasurer, or vice-president of the corporation in charge of a principal business function, or any other person who performs similar policy or decision-making functions for the corporation; or the manager of one or more manufacturing, production, or operating facilities employing more than 250 persons or having gross annual sales or expenditures exceeding \$25 million (in second-quarter 1980 dollars), if authority to sign documents has been assigned or delegated to the manager in accordance with corporate procedures. Corporate procedures governing authority to sign permit or post-closure order applications may provide for assignment or delegation to applicable corporate positions rather than to specific individuals.

(2) For a partnership or sole proprietorship, the application shall be signed by a general partner or the proprietor, respectively.

(3) For a municipality, state, federal, or other public agency, the application shall be signed by either a principal executive officer or a ranking elected official. For purposes of this paragraph, a principal executive officer of a federal agency includes the chief executive officer of the agency, or a senior executive officer having responsibility for the overall operations of a principal geographic unit of the agency (e.g., regional administrator of the EPA).



Notice of Termination (NOT) for Authorizations under TPDES General Permit TXRo50000

ePermits: This form is available on our online permitting system.

Sign up for online permitting at: <https://www3.tceq.texas.gov/steers/>

What is the authorization number to be terminated?

TXR05 _____ or TXRNE _____

Section 1. OPERATOR (Permittee)

a) What is the Customer Number (CN) issued to this entity?

CN _____

b) What is the Legal Name of the current operator?

c) Provide the contact information for the Operator (Responsible Authority).

Prefix (Mr. Ms. or Miss): _____

First and Last Name: _____ Suffix: _____

Title: _____ Credentials: _____

Phone Number: _____ Fax Number: _____

Email: _____

Mailing Address: _____

City, State, and Zip Code: _____

Country Mailing Information, if outside USA: _____

Section 2. APPLICATION CONTACT

This is the person TCEQ will contact if additional information is needed regarding this application.

Is the application contact the same as the operator identified above? Yes No

If Yes, go to Section 3.

If No, complete section below

Prefix (Mr. Ms. or Miss): [redacted]
First and Last Name: [redacted] Suffix: [redacted]
Title: [redacted] Credentials: [redacted]
Phone Number: [redacted] Fax Number: [redacted]
Email: [redacted]
Mailing Address: [redacted]
City, State, and Zip Code: [redacted]
Country Mailing Information, if outside USA: [redacted]

Section 3. REGULATED ENTITY (RE) INFORMATION ON PROJECT OR SITE

- a) TCEQ issued RE Reference Number (RN): RN [redacted]
- b) Name of project or site as known by the local community: [redacted]
- c) County, or counties if more than 1: [redacted]
- d) Latitude: [redacted] Longitude: [redacted]
- e) Site Address/Location:

If the site has a physical address such as 12100 Park 35 Circle, Austin, TX 78753, complete Section 3A.

If the site does not have a physical address, provide a location description in Section 3B.
Example: located on the north side of FM 123, 2 miles west of the intersection of FM 123 and Highway 1.

Section 3A: Physical Address of Project or Site:

Street Number and Name: [redacted]
City, State, and Zip Code: [redacted]

Section 3B: Site Location Description:

Location description: [redacted]
[redacted]

City where the site is located or, if not in a city, what is the nearest city: [redacted]
Zip Code where the site is located: [redacted]

Section 4. REASON FOR TERMINATION

Check the reason for termination:

- There is no longer any industrial activity at this site that is regulated under the general permit.
- The facility is now under the control of a new Operator.
- The planned industrial activity has been canceled.
- The discharge is now authorized under an alternate TPDES permit.
- The activity is now authorized under an alternate Notice of Intent.

Section 5. CERTIFICATION

Signatory Name: _____

Signatory Title: _____

I certify under penalty of law that this document and all attachments were prepared under my direction or supervision in accordance with a system designed to assure that qualified personnel properly gather and evaluate the information submitted. Based on my inquiry of the person or persons who manage the system, or those persons directly responsible for gathering the information, the information submitted is, to the best of my knowledge and belief, true, accurate, and complete. I am aware there are significant penalties for submitting false information, including the possibility of fine and imprisonment for knowing violations.

I further certify that I am authorized under 30 Texas Administrative Code §305.44 to sign and submit this document, and can provide documentation in proof of such authorization upon request.

Signature (use blue ink): _____

Date: _____

Instructions for Notice of Termination (NOT) for Authorizations under TPDES General Permit TXR050000

GENERAL INFORMATION

Where to Send the Notice of Termination (NOT):

BY REGULAR U.S. MAIL:

Texas Commission on Environmental Quality
Stormwater Processing Center (MC-228)
P.O. Box 13087
Austin, Texas 78711-3087

BY OVERNIGHT/EXPRESS MAIL:

Texas Commission on Environmental Quality
Stormwater Processing Center (MC-228)
12100 Park 35 Circle
Austin, TX 78753

TCEQ Contact List:

Application status and form questions:	512-239-3700, swpermit@tceq.texas.gov
Technical questions:	512-239-4671, swgp@tceq.texas.gov
Environmental Law Division:	512-239-0600
Records Management - obtain copies of forms:	512-239-0900
Reports from databases (as available):	512-239-DATA (3282)
Cashier's office:	512-239-0357 or 512-239-0187

Notice of Termination Process:

A Notice of Termination is **effective on the date postmarked for delivery to TCEQ.**

When your NOT is received by the program, the form will be processed as follows:

- 1) **Administrative Review:** The form will be reviewed to confirm the following:
 - the permit number is provided
 - the permit is active and has been approved
 - the entity terminating the permit is the current permittee
 - the site information matches the original permit record
 - the form has the required original signature with title and date
- 2) **Notice of Deficiency:** If an item is incomplete or not verifiable as indicated above, a phone call will be made to the applicant to clear the deficiency. A letter will not be sent to the permittee if unable to process the form.
- 3) **Confirmation of Termination:** A Notice of Termination Confirmation letter will be mailed to the operator.

Change in Operator:

An authorization under the general permit is not transferable. If the operator of the regulated entity changes, the present permittee must submit a Notice of Termination and the new operator must submit a Notice of Intent. The NOT and NOI must be submitted not later than 10 days prior to the change in Operator status.

Annual Water Quality Fee:

This fee is assessed to permittees with an active authorization under the general permit on September 1 of each year. The designated billing contact will receive an invoice for payment of the annual fee in November of each year. The payment will be due 30 days from the invoice date. A 5% penalty will be assessed if the payment is not received by TCEQ by the due date. Annual fee assessments cannot be waived as long as the authorization under the general permit is active on September 1.

It is important for the permittees to submit a NOT when coverage under the general permit is no longer required. A NOT is effective on the postmarked date of mailing the form to TCEQ. It is recommended that the NOT be mailed using a method that documents the date mailed and received by TCEQ.

INSTRUCTIONS FOR FILLING OUT THE FORM

The majority of permit information related to the current operator and regulated entity are available at the following website: http://www2.tceq.texas.gov/wq_dpa/index.cfm.

Section 1. Operator (Current Permittee):

- a) Customer Number (CN)
TCEQ's Central Registry assigns each customer a number that begins with CN, followed by nine digits. This is not a permit number, registration number, or license number. The Customer Number, for the current permittee, is available at the following website: http://www2.tceq.texas.gov/wq_dpa/index.cfm.
- b) Legal Name of Operator
The operator must be the same entity as previously submitted on the original Notice of Intent for the permit number provided. The current operator name, as provided on the current authorization, is available at the following website: http://www2.tceq.texas.gov/wq_dpa/index.cfm.
- c) Contact Information for the Operator (Responsible Authority)
Provide information for person signing the NOT application in the Certification section. This person is also referred to as the Responsible Authority.

Provide a complete mailing address for receiving mail from the TCEQ. Update the address if different than previously submitted for the Notice of Intent or Notice of Change. The mailing address must be recognized by the US Postal Service. You may verify the address on the following website: <https://tools.usps.com/go/ZipLookupAction!input.action>.

The phone number should provide contact to the operator.

The fax number and e-mail address are optional and should correspond to the operator.

Section 2. Application Contact:

Provide the name, title and contact information of the person that TCEQ can contact for additional information regarding this application.

Section 3. Regulated Entity (RE) Information on Project or Site:

- a) Regulated Entity Reference Number (RN)
A number issued by TCEQ's Central Registry to sites where an activity regulated by TCEQ. This is not a permit number, registration number, or license number. The Regulated Entity Reference Number is available at the following website:
http://www2.tceq.texas.gov/wq_dpa/index.cfm.
- b) Name of the Project or Site
Provide the name of the site as known by the public in the area where the site is located.
- c) County
Identify the county or counties in which the regulated entity is located.
- d) Latitude and Longitude
Enter the latitude and longitude of the site in degrees, minutes, and seconds or decimal form. The latitude and longitude as provided on the current authorization is available at the following website: http://www2.tceq.texas.gov/wq_dpa/index.cfm.
- e) Site/Project (RE) Physical Address/Location Information
The physical address/location information, as provided on the current authorization, is available at the following website: http://www2.tceq.texas.gov/wq_dpa/index.cfm.

Section 3A. If a site has an address that includes a street number and street name, enter the complete address for the site. If the physical address is not recognized as a USPS delivery address, you may need to validate the address with your local police (911 service) or through an online map site used to locate the site. Please confirm this to be a complete and valid address. Do not use a rural route or post office box for a site location.

Section 3B. If a site does not have an address that includes a street number and street name, provide a complete written location description. For example: "The site is located on the north side of FM 123, 2 miles west of the intersection of FM 123 and Highway 1."

Provide the city (or nearest city) and Zip Code of the facility location.

Section 4. Reason for Termination:

The Notice of Termination form is only for use to terminate the authorization (permit). The Permittee must indicate the specific reason for terminating by checking one of the options. If the reason is not listed then provide an attachment that explains the reason for termination.

Please read your general permit carefully to determine when to terminate your permit. Permits will not be reactivated after submitting a termination form. The termination is effective on the date postmarked for delivery to TCEQ.

Section 5. Certification:

The certification must bear an original signature of a person meeting the signatory requirements specified under 30 Texas Administrative Code §305.44.

IF YOU ARE A CORPORATION:

The regulation that controls who may sign an application form is 30 Texas Administrative Code §305.44(a), which is provided below. According to this code provision, any corporate representative may sign an NOI or similar form so long as the authority to sign such a document

has been delegated to that person in accordance with corporate procedures. By signing the NOI or similar form, you are certifying that such authority has been delegated to you. The TCEQ may request documentation evidencing such authority.

IF YOU ARE A MUNICIPALITY OR OTHER GOVERNMENT ENTITY:

The regulation that controls who may sign an NOI or similar form is 30 Texas Administrative Code §305.44(a), which is provided below. According to this code provision, only a ranking elected official or principal executive officer may sign an NOI or similar form. Persons such as the City Mayor or County Commissioner will be considered ranking elected officials. In order to identify the principal executive officer of your government entity, it may be beneficial to consult your city charter, county or city ordinances, or the Texas statutes under which your government entity was formed. An NOI or similar document that is signed by a government official who is not a ranking elected official or principal executive officer does not conform to §305.44(a) (3). The signatory requirement may not be delegated to a government representative other than those identified in the regulation. By signing the NOI or similar form, you are certifying that you are either a ranking elected official or principal executive officer as required by the administrative code. Documentation demonstrating your position as a ranking elected official or principal executive officer may be requested by the TCEQ.

If you have any questions or need additional information concerning the signatory requirements discussed above, please contact the Texas Commission on Environmental Quality's Environmental Law Division at 512-239-0600.

30 TEXAS ADMINISTRATIVE CODE §305.44. SIGNATORIES TO APPLICATIONS

(a) All applications shall be signed as follows.

(1) For a corporation, the application shall be signed by a responsible corporate officer. For purposes of this paragraph, a responsible corporate officer means a president, secretary, treasurer, or vice-president of the corporation in charge of a principal business function, or any other person who performs similar policy or decision-making functions for the corporation; or the manager of one or more manufacturing, production, or operating facilities employing more than 250 persons or having gross annual sales or expenditures exceeding \$25 million (in second-quarter 1980 dollars), if authority to sign documents has been assigned or delegated to the manager in accordance with corporate procedures. Corporate procedures governing authority to sign permit or post-closure order applications may provide for assignment or delegation to applicable corporate positions rather than to specific individuals.

(2) For a partnership or sole proprietorship, the application shall be signed by a general partner or the proprietor, respectively.

(3) For a municipality, state, federal, or other public agency, the application shall be signed by either a principal executive officer or a ranking elected official. For purposes of this paragraph, a principal executive officer of a federal agency includes the chief executive officer of the agency, or a senior executive officer having responsibility for the overall operations of a principal geographic unit of the agency (e.g., regional administrator of the EPA).

APPENDIX I

RECORD OF TEMPORARY/PERMANENT CEASING OF CONSTRUCTION ACTIVITIES

Record of Temporary/Permanent Ceasing of Construction Activities

Project Activity Area	Date Activities Ceased	Temporary* or Permanent	Date Soil Stabilization Implemented	Date Activities Resumed	Initials

* "Temporarily Ceased" means inactive for less than 21 consecutive days.

APPENDIX J

DELEGATION OF SIGNATORIES

Executive Director
Texas Commission on Environmental Quality
Storm Water and Pretreatment Team
P.O. Box 13087, MC-148
Austin, TX 78711-3087

Subject: Delegation of Signatories to Reports

Facility/Company/Site Name: LEMON CREEK RANCH MULTIFAMILY - ALLEN HARRISON
TPDES Permit Number: _____

Dear Executive Director:

This letter serves to designate the following people or positions as authorized personnel for signing reports, storm water pollution prevention plans, certifications or other information requested by the Executive Director or required by the general permit, as set forth by 30 TAC §305.128 (see page 2).

Name or Position	LEMON CREEK VEP, CURRENT PROPERTY OWNER
Name or Position	ALLEN HARRISON CO., MULTI-FAMILY DEVELOPER
Name or Position	
Name or Position	

I understand that this authorization does not extend to the signing of a Notice of Intent for obtaining coverage under a storm water general permit.

By signing this authorization, I confirm that I meet the requirements to make such a designation as set forth in 30 TAC §305.44 (see page 2).

Sincerely,

Name

Title

Date

RELEVANT PROVISIONS

305.128(a) All reports requested by permits and other information requested by the executive director shall be signed by a person described in §305.44(a) of this title (relating to Signatories to Applications) or by a duly authorized representative of that person. A person is a duly authorized representative only if:

(1) the authorization is made in writing by a person described in §305.44(a) of this title (relating to Signatories to Applications);

(2) the authorization specifies either an individual or a position having responsibility for the overall operation of the regulated facility or activity or for environmental matters for the applicant, such as the position of plant manager, operator of a well or well field, environmental manager, or a position of equivalent responsibility. (A duly authorized representative may thus be either a named individual or any individual occupying a named position); and

(3) the written authorization is submitted to the executive director.

(b) If an authorization under this section is no longer accurate because of a change in individuals or position, a new authorization satisfying the requirements of this section must be submitted to the executive director prior to or together with any reports, information, or applications to be signed by an authorized representative.

(c) Any person signing a report required by a permit shall make the certification set forth in §305.44(b) of this title (relating to Signatories to Applications).

305.44(a) All applications shall be signed as follows.

(1) For a corporation, the application shall be signed by a responsible corporate officer. For purposes of this paragraph, a responsible corporate officer means a president, secretary, treasurer, or vice-president of the corporation in charge of a principal business function, or any other person who performs similar policy or decision-making functions for the corporation; or the manager of one or more manufacturing, production, or operating facilities employing more than 250 persons or having gross annual sales or expenditures exceeding \$25 million (in second-quarter 1980 dollars), if authority to sign documents has been assigned or delegated to the manager in accordance with corporate procedures. Corporate procedures governing authority to sign permit or post-closure order applications may provide for assignment or delegation to applicable corporate positions rather than to specific individuals.

(2) For a partnership or sole proprietorship, the application shall be signed by a general partner or the proprietor, respectively.

(3) For a municipality, state, federal, or other public agency, the application shall be signed by either a principal executive officer or a ranking elected official. For purposes of this paragraph, a principal executive officer of a federal agency includes the chief executive officer of the agency, or a senior executive officer having responsibility for the overall operations of a principal geographic unit of the agency (e.g., regional administrator of the EPA).

(b) A person signing an application shall make the following certification: "I certify under penalty of law that this document and all attachments were prepared under my direction or supervision in accordance with a system designed to assure that qualified personnel properly gather and evaluate the information submitted. Based on my inquiry of the person or persons who manage the system, or those persons directly responsible for gathering the information, the information submitted is, to the best of my knowledge and belief, true, accurate, and complete. I am aware there are significant penalties for submitting false information, including the possibility of fine and imprisonment for knowing violations."

APPENDIX K

MATERIAL MANAGEMENT PRACTICES

MATERIAL MANAGEMENT PRACTICES

The following are the material management practices that will be used to reduce risk of spills or other accidental exposure of materials and substances to storm water runoff:

1. Good Housekeeping: The following good housekeeping practices will be followed onsite during the construction project:
 - An effort will be made to store only enough product required to do the job.
 - All materials stored on-site will be stored in a neat, orderly manner in their appropriate containers and, if possible, under a roof or other enclosure.
 - Products will be kept in their original containers with the original manufacturer's label.
 - Substances will not be mixed with one another unless recommended by the manufacturer.
 - Whenever possible, all of a product will be used up before disposing of the container.
 - Manufacturers' recommendations for proper use and disposal will be followed.
 - Designated areas for equipment maintenance and repair (control of oil, grease and fuel spills).
 - Waste receptacles with regular collection for litter and construction debris.
 - Equipment washdown area on-site with appropriate control of wash waters (including concrete truck wash down).
 - Protected storage areas for chemicals, paints, solvents, fertilizers and other potentially toxic materials.
 - Adequately maintained sanitary facilities.
 - Proper control of raw materials stored on-site (for example, sand, aggregate and cement used in the manufacture of concrete or stockpiles of topsoil).
 - Street sweeping or cleaning.
 - Removal of inlet protection barriers during major rainfall events if flooding occurs and verification that reinforced filter fabric fences are in proper condition prior to all rainfall events.
 - The site superintendent will ensure proper use and disposal of materials onsite.
2. Hazardous Products: The following practices are used to reduce the risks associated with hazardous materials.
 - Products will be kept in original containers unless they are not re-sealable.
 - Paints, solvents, fertilizer, fuel (small containers), and other stored chemical substances will be kept within an enclosure to protect the containers and the floor of the enclosure, from wind, precipitation, and storm water runoff.
 - Fuel storage and filling areas will be bermed off to provide collection of any spills and prevent exposure to storm water runoff.
 - Original labels and Material Safety Data Sheets (MSDS) will be retained on-site and available for review by workers.
 - If surplus product must be disposed of, manufacturers' or local and State recommended methods for proper disposal will be followed.

PRODUCT SPECIFIC PRACTICES

The following product specific practices will be followed onsite:

1. Petroleum Products: All onsite vehicles will be monitored for leaks and receive regular preventive maintenance to reduce the chance of leakage. Petroleum products will be stored in tightly sealed containers, which are clearly labeled. Any asphalt substances used onsite will be applied according to the manufacturer's recommendations.
2. Fertilizers: Fertilizers used will be applied only in the minimum amounts recommended by the manufacturer. Storage will be in a covered shed.
3. Paints: All containers will be tightly sealed and stored when not required for use. Excess paint will not be discharged to the storm sewer system but will be properly disposed of according to manufacturers' instructions or State and local regulations.
4. Concrete Trucks: Discharges of concrete truck wash out at construction sites may be authorized if conducted in accordance with the requirements of Part V of the general permit.

SPILL CONTROL PRACTICES

In addition to the good housekeeping and material management practices discussed in the previous sections of this plan, the following practices will be followed for spill prevention and cleanup:

- Manufacturers' recommended methods for spill cleanup will be maintained on-site in the material data sheets (MSDS) and site personnel will be made aware of the procedures and the location of the information and cleanup supplies.
- Materials and equipment necessary for spill cleanup will be kept in the material storage area onsite. Equipment and materials will include but not be limited to brooms, dust pans, mops, rags, gloves, goggles, kitty litter, sand, sawdust and plastic and metal trash containers specifically for this purpose.
- All spills will be cleaned up immediately after discovery.
- The spill area will be kept well ventilated and personnel will wear appropriate protective clothing to prevent injury from contact with a hazardous substance.
- Contact the MS4 Operator, TCEQ (800-832-8224), and the National Response Center (800-424-8802) to inform of any spill of toxic or hazardous material regardless of the size.

The spill prevention plan will be adjusted to include measures to prevent this type of spill from recurring and how to clean up the spill if there is another one. A description of the spill, what caused it, and the cleanup measures will also be included.

APPENDIX L

NON-STORM WATER DISCHARGE INVENTORY

NON-STORM WATER DISCHARGE INVENTORY

Mark the materials or substances listed below expected to be present onsite during construction:

- | | | |
|--|--|--|
| <input checked="" type="checkbox"/> Concrete | <input type="checkbox"/> Detergents | <input checked="" type="checkbox"/> Paints (enamel/latex) |
| <input checked="" type="checkbox"/> Metal Studs | <input type="checkbox"/> Fuels | <input checked="" type="checkbox"/> Lubricants |
| <input checked="" type="checkbox"/> Fertilizers | <input checked="" type="checkbox"/> Petroleum Based Products | <input checked="" type="checkbox"/> Cleaning Solvents |
| <input checked="" type="checkbox"/> Masonry Block | <input checked="" type="checkbox"/> Electrical Equipment and Materials | <input checked="" type="checkbox"/> Asphalt and Asphalt Related Products |
| <input type="checkbox"/> Tar | <input checked="" type="checkbox"/> Roof Shingles | <input checked="" type="checkbox"/> Wood |
| <input checked="" type="checkbox"/> Steel Products | <input type="checkbox"/> _____ | <input type="checkbox"/> _____ |
| <input type="checkbox"/> _____ | <input type="checkbox"/> _____ | <input type="checkbox"/> _____ |

AUTHORIZED NON STORMWATER DISCHARGES ANTICIPATED DURING THE PROJECT

Mark the following non-storm water discharges expected to occur from the site during the construction period (refer to general permit in Appendix G for additional information):

- discharges from firefighting activities,
- uncontaminated fire hydrant flushings, which include flushings from systems that utilize potable water, surface water, or groundwater that does not contain additional pollutants,
- water from the routine external washing of vehicles, the external portion of buildings or structures, and pavement, where detergents and soaps are not used and where spills or leaks of toxic or hazardous materials have not occurred and where the purpose is to remove mud, dirt, or dust,
- uncontaminated water used to control dust,
- potable water sources including waterline flushings,
- uncontaminated air conditioning condensate,
- uncontaminated ground water or spring water, including foundation or footing drains where flows are not contaminated with industrial materials such as solvents,
- lawn watering and similar irrigation drainage,
- runoff from concrete batch plants (refer to Part IV of general permit),
- concrete truck wash out (refer to Part V of general permit).

APPENDIX N

SEDIMENTATION BASIN INFORMATION AND CALCULATIONS

Sites With Drainage Areas of Ten or More Acres

A sedimentation basin is required, where feasible, for a common drainage location that serves an area with ten (10) or more acres disturbed at one time.

A sedimentation basin may be temporary or permanent, and must provide sufficient storage to contain a calculated volume of runoff from a 2-year, 24-hour storm from each disturbed acre drained. When calculating the volume of runoff from a 2-year, 24-hour storm event, it is not required to include the flows from offsite areas and flow from onsite areas that are either undisturbed or have already undergone permanent stabilization, if these flows are diverted around both the disturbed areas of the site and the sediment basin. Capacity calculations shall be included in Appendix N of this SWP3.

Where rainfall data is not available or a calculation cannot be performed, the sedimentation basin must provide at least 3,600 cubic feet of storage per acre drained until final stabilization of the site.

If a sedimentation basin is not feasible, then the permittee shall provide equivalent control measures until final stabilization of the site. In determining whether installing a sediment basin is feasible, the permittee may consider factors such as site soils, slope, available area, public safety, precipitation patterns, site geometry, site vegetation, infiltration capacity, geotechnical factors, depth to groundwater, and other similar considerations. The permittee shall document the reason that the sediment basins are not feasible, and shall utilize equivalent control measures, which may include a series of smaller sediment basins.

Sites With Drainage Areas Less than Ten Acres

Sediment traps and sediment basins may be used to control solids in storm water runoff for drainage locations serving less than ten (10) acres.

Alternatively, a sediment basin that provides storage for a calculated volume of runoff from a 2-year, 24-hour storm from each disturbed acre drained may be utilized. Where rainfall data is not available or a calculation cannot be performed, a temporary or permanent sediment basin providing 3,600 cubic feet of storage per acre drained may be provided. If a calculation is performed, then the calculation shall be included in Appendix N of this SWP3.

APPENDIX O

LOCAL REQUIREMENTS

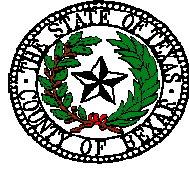

**INFRASTRUCTURE SERVICES DEPARTMENT
ENVIRONMENTAL SERVICES DIVISION**

233 N. Pecos – La Trinidad, Suite 420

San Antonio, TX 78207

(210) 335-6700 (voice) (210) 335-6713 (fax)

To: Permit Applicant

From: Bexar County Storm Water Department .

Dear Applicant,

Please read the Site Development Permit Application carefully due to changes that have been made to the application. Please fill out each part of the permit on page 1 to the best of your knowledge and read page 2 to comply with the requirements of the TCEQ TPDES General Permit, the Bexar County Storm Water Quality Site Development Permit and inspection process. If you require assistance please call us at 335-6700.

Thank You,

Andrew Winter P.E.
Environmental Engineer

DIVISION 5. - PROHIBITED DISCHARGES INTO THE MUNICIPAL SEPARATE STORM SEWER SYSTEM

Subdivision A. - General MS4 Protections

Sec. 34-701. - Definitions.

The following terms shall have the following meanings for the purpose of this division:

- (a) *The San Antonio Municipal Separate Storm Sewer System (MS4)*. The system of conveyances, including but not limited to, roads with drainage systems, municipal streets, catch basins, curbs, gutters, ditches, creeks, streams, tributaries, man-made channels, or storm drains, which:
 - (1) Provide collection or conveyance of stormwater, rain water, flood water, or other surface water; and
 - (2) Are located on public property; and
 - (3) Are not designed and intended to be part of the collection system of a sanitary sewer system utilized by a publicly owned treatment works (POTW) as defined in Title 40 C.F.R. 122.2.
- (b) *Brush cuttings, clippings*. All herbaceous materials, including lawn trimmings and leaves.
- (c) *Household hazardous waste*. Waste from materials utilized for residential or housekeeping purposes containing regulated substances which either singularly or by its interaction with other wastes or by its accumulation in the MS4 becomes injurious or potentially injurious to human, plant, or animal life, or property. For purposes of this division household hazardous wastes include but are not limited to paint, paint thinners, paint solvents, beaches, and drain cleaners.
- (d) *Pesticide*. Any substance or mixture of substances intended for preventing, destroying, repelling, or mitigating any pest, and/or any substance or mixture of substances intended for use as a plant regulator, defoliant, or desiccant.
- (e) *Rubbish*. Inorganic solid waste including paper, rags, cartons, wood, excelsior, furniture, rubber, plastics, glass, crockery, tin and aluminum cans, metal furniture, and other like materials.

(Ord. No. 80574, § 16, 8-4-94)

Sec. 34-702. - Prohibited discharges into the MS4.

- (a) It shall be a violation of this division for any person to deposit, throw, drain, discharge, cause or allow to be deposited, thrown, drained or discharged, or otherwise cause to be injected into the MS4, or any storm sewer manhole, catch basin, private drain, ditch, street, gutter, creek, stream, tributary, or any other drainage device which connects with or drains into the MS4, any of the following described materials or substances within the corporate limits of the City of San Antonio:
- (1) Any acid waste materials;
 - (2) Any alkaline waste materials;
 - (3) Any water or waste containing free-floating, or insoluble oil;
 - (4) Any gasoline, naphtha, fuel oil, mineral oil or other flammable or explosive liquid, solid or gas;
 - (5) Any noxious, malodorous, poisonous, or reactive substance which, either singularly or by interaction with other substances, or by its accumulation in the MS4 becomes injurious or potentially injurious to human, plant or animal life, or property; or
 - (6) Any domestic wastewater or industrial wastewater as defined in Article V, Division 3 of this chapter.
- (b) It shall be a defense to prosecution under this section that such person was authorized to commit any act under a valid permit from the Texas Natural Resource Conservation Commission or the United States Environmental Protection Agency, which would otherwise constitute a violation at the time of commission.

Commentary: It is the intent of this division to prohibit indiscriminate discharging to the MS4; such indiscriminate discharging includes dumping or releasing of any accumulations of process materials, washing or cleaning materials or other wastes into the MS4. It is also the intent to eliminate improper storage or handling of dangerous, hazardous, or otherwise harmful materials in such a manner as to cause or allow their discharge into the MS4. However, these regulations are not intended to prohibit discharge of non-contaminated and non-polluting water, such as fire hydrant flushing, runoff from fire fighting, non-chlorinated swimming pool or hot tub drainage, uncontaminated pumped groundwater, discharges from potable water sources, non-contact cooling waters, ventilation and air conditioning condensation water that POTWs require to be discharged to separate storm sewers rather than to sanitary sewers, etc.

(Ord. No. 80574, § 16, 8-4-94)

Sec. 34-703. - Placing brush cuttings, clippings, and/or rubbish into the MS4.

- (a) It shall be a violation of this division for any person to deposit, discard or dump, or cause or allow to be deposited, discarded or dumped any brush cuttings, clippings, or rubbish within the MS4.
- (b) It shall be a violation of this division for any person to place or cause or allow to be placed or dropped, brush cuttings, clippings, and/or rubbish within any street in the corporate limits of the city in such a manner that the same may be washed by the flow of water into the MS4.

Commentary: It is the intent of this section to restrict placement of rubbish, brush, lawn clippings or leaves, etc. into the MS4. It is also the intent to require that during certain seasons when leaves are shed that these materials are removed properly and prevented from collecting in mass quantities in the streets or MS4. It is recognized that from time to time during certain seasons or during normal yard maintenance, leaves, clippings, etc. will fall into the streets.

(Ord. No. 80574, § 16, 8-4-94)

Sec. 34-704. - Placing household hazardous wastes into the MS4.

- (a) It shall be a violation of this division for any person to place, or cause or allow to be placed, a household hazardous waste within the MS4.
- (b) It shall be a violation of this division for any person to place, or cause or allow to be placed, a household hazardous waste within any street in the corporate limits of the city in such a manner that the same may be washed by the flow of water into the MS4.

Commentary: The intent of this ordinance is to prohibit those conducting household activities such as cleaning, renovating, painting, auto repair, and other similar activities which utilize household hazardous wastes from discarding such wastes into the MS4, or from performing any activity that would result in the contamination of the MS4 with such household hazardous wastes.

(Ord. No. 80574, § 16, 8-4-94)

Sec. 34-705. - Prohibiting the improper use of pesticides in order to keep them from entering the MS4.

- (a) It shall be a violation of this division for any person to cause or allow a pesticide to enter into the MS4.

- (b) It shall be a violation of this division for any person to utilize a pesticide in a manner inconsistent with the proper usage set out in the labelling for such pesticide in accordance with the Federal Insecticide, Fungicide, and Rodenticide Act (FIFRA).
- (c) It shall be a violation of this division for any person to utilize a pesticide which is not properly labelled in accordance with FIFRA.
- (d) It shall be a defense to prosecution under this section that the person accused of such violation utilized a pesticide in accordance with the requirements of FIFRA in a manner consistent with its labelling. The term "labelling" pursuant to Section 136 of FIFRA means all labels and all other written, printed or graphic matter:
 - (1) Accompanying the pesticide or device at any time; or
 - (2) To which reference is made on the label or in literature accompanying the pesticide or device except to current official publications of the Environmental Protection Agency, the United States Departments of Agriculture and Interior, the Department of Health and Human Services, state experiment stations, state agricultural colleges, and other federal or state institutions or agencies authorized by law to conduct research in the field of pesticides.

Commentary: It is recognized that excess pesticides will migrate into the MS4 even under normal and proper usage. It is the intent of this ordinance to restrict the usage of those chemicals to the manner deemed appropriate by their manufacturer and consistent with FIFRA.

(Ord. No. 80574, § 16, 8-4-94)

Sec. 34-706. - Authority to enforce outside the city limits.

- (a) Pursuant to the authority granted under Section 401.002 V.T.C.A. Local Government Code, a prohibited act or discharge identified in sections 34-702 through 34-705 hereof shall be enforceable outside the city limits if the prohibited act or discharge:
 - (1) Causes or contributes to the pollution of a stream, drain or tributary which provides a source of recharge water for the Edwards Aquifer; or
 - (2) Causes harm to, pollutes, or is in any way contrary to the protection of any watershed which drains into the MS4.
- (b)

It shall be a defense to prosecution under this section that a person was authorized to commit the prohibited discharges set out in section 34-702 herein, under a valid permit from the Texas Natural Resource Conservation Commission or the United States Environmental Protection Agency.

(Ord. No. 80574, § 16, 8-4-94)

Sec. 34-707. - Authority to enforce within 5,000 feet outside the city limits.

- (a) Committing a prohibited act or discharge, as set out in sections 34-702 through 34-705 herein, within five thousand (5,000) feet outside the corporate limits of the City of San Antonio is found to be contrary to the public health and welfare and is hereby deemed and declared to be a nuisance pursuant to Section 217.042 of the Local Government Code.
- (b) It shall be a defense to prosecution under this section that a person was authorized to commit the prohibited discharges set out in sections 34-702 through 34-705 herein under a valid permit from the Texas Natural Resource Conservation Commission or the United States Environmental Protection Agency.

(Ord. No. 80574, § 16, 8-4-94)

Sec. 34-708. - Criminal penalty.

- (a) A conviction for violation of this division shall constitute a class C misdemeanor. A person convicted of a violation of this division shall be fined a minimum amount of not less than two hundred dollars (\$200.00) per violation and a maximum amount of not more than two thousand dollars (\$2,000.00) per violation. Each violation of a particular section of this division shall constitute a separate offense, and each day an offense continues shall be considered a new violation for purposes of enforcing this division. A culpable mental state is not required to prove an offense under this ordinance.
- (b) The president/CEO of SAWS is hereby authorized to designate qualified SAWS personnel to serve notices of violations of this section and to take all necessary actions to file a complaint with the municipal prosecutor's office.

(Ord. No. 80574, § 16, 8-4-94)

Sec. 34-709. - Civil penalty.

A civil penalty in an amount not to exceed five thousand dollars (\$5,000.00) per violation of this division may be imposed. Each violation of a particular section of this division shall constitute a separate offense, and each day such an offense continues shall be considered a new violation for purposes of enforcing this division.

(Ord. No. 80574, § 16, 8-4-94)

Sec. 34-710. - Additional enforcement remedies.

- (a) In addition to any other remedies provided by this division, the City of San Antonio and SAWS may, at any time, seek legal and/or equitable remedies or may file charges against any person, corporation, or other entity believed to be in violation of this division. In furtherance thereof, the SAWS legal department is hereby authorized and instructed to commence any action, in law or in equity, including the filing of charges for the purpose of enforcing this division.
- (b) The use of negotiated civil settlements or other methods of alternative dispute resolution to reach a civil settlement is hereby authorized; provided that the civil penalty imposed by any such agreement or settlement is of a sufficient amount in relation to the violations to which they provide a sanction.

(Ord. No. 80574, § 16, 8-4-94)

Sec. 34-711. - Conflict.

No provision of this division is intended to, nor shall any part or portion hereof be construed, so as to conflict with the Texas Water Code.

(Ord. No. 80574, § 16, 8-4-94)

Sec. 34-712. - Severability.

If any provision of this division or the application thereof to any person or circumstance shall be held to be void or invalid for any reason, the remainder of this division and the application of such provision to other persons and circumstances shall nevertheless be valid, and the city council hereby declares that this division would have been enacted without such invalid provision.

(Ord. No. 80574, § 16, 8-4-94)

Secs. 34-713—34-800. - Reserved.

Subdivision B. - Stormwater Compliance for Construction Activity

Sec. 34-801. - Statement of purpose.

The intent of the ordinance from which this subdivision derives, creating subdivision B, is to satisfy conditions imposed by the City's Texas Pollutant Discharge Elimination System (TPDES) Permit issued by the Texas Commission on Environmental Quality (TCEQ).

All construction addressed by the ordinance from which this subdivision derives is intended to conform to best management practices. Applicable best management practices (BMP) are presently outlined in the Texas Commission on Environmental Quality (TCEQ) Technical Guidance On Best Management Practices, June 1999, Document No. RG-348 (Revised July 2005). The TCEQ guidance may be updated by the agency or revised by the city for integration into the city's technical guidance manual for local construction activity. All these sources are merely recommended guidance and examples for responsible parties. Choice of techniques is at the option of the responsible party.

(Ord. No. 94002, § 1, 5-24-01; Ord. No. 2014-06-19-0472, § 1(Exh. A), 6-19-14)

Sec. 34-802. - Definitions.

When used in this subdivision B, the following terms shall have the following meanings:

Best management practices (BMP): A technique or series of structural and non-structural techniques and practices which, when used in an erosion control plan or considered as part of a construction site's housekeeping efforts, are proven to be effective in controlling construction-related runoff, erosion, sedimentation, and associated pollutants. Applicable BMP's can be found in TCEQ approved BMP Guidance manuals.

Construction activity: Clearing, grading or filling of land, dozing or mechanical removal of trees which dozing or mechanical removal disturbs the soil, excavation for installation of utility lines, streets, drainage facilities, and site preparation for housing and commercial development, as well as on-going construction activities which produce waste products. Land being modified by either excavation or fill of material upon an existing mantle of soils is considered a construction activity and subject to the terms of this Ordinance unless otherwise permitted under a Multi-

sector Industrial Storm Water Permit. Prior to any modification to an existing mantle soil grade the owner of the property must meet City requirements for grading and drainage applicable to property modifications.

Director of public works: The director of public works of the City of San Antonio, including his/her designees.

EPA: The United States Environmental Protection Agency.

Erosion: The wearing away of the ground surface as a result of the movement of wind, water and/or ice.

Extraterritorial jurisdiction (ETJ): The un-incorporated area contiguous to corporate boundaries of the city that is located within five (5) miles of those boundaries, defined by the Texas Local Government Code and as such Code may be amended. Applicable limits of the ETJ, for enforcement purposes of this subdivision, are only those areas within the first five thousand (5,000) feet of San Antonio's corporate boundaries within the ETJ.

Final inspection: Occurs after responsible party meets definition of final stabilization and files a Notice of Termination (NOT) form, if required by state or federal law, at which time SAWS will conduct a final inspection to verify both compliance with final stabilization and removal of the temporary BMP's from the site has occurred. Final inspections will be required at both small construction sites and large construction Sites. Secondary operators are required to complete site notices and complete a NOT form as required under the TPDES permit.

Final stabilization: Reference to standards in the TCEQ TPDES general permit for storm water discharges for construction activities concerning development acreage that:

- (1) Where state or federally regulated development acreage is concerned, all soil disturbing activities at the site have been completed, and a uniform perennial vegetative cover, with a density of seventy (70) percent of the native background vegetative cover for the area has been established on all unpaved areas and areas not covered by permanent structures or equivalent permanent stabilization measures have been employed and
- (2) Where local, individual lots associated with residential or commercial construction are concerned, by either (a) the responsible party complying with cover requirements guided by federal or state standards recited above,

or (b) the responsible party establishing temporary stabilization including perimeter controls and informing the home buyer or commercial purchaser in writing of the need for and benefits of final stabilization.

Grade: The vertical location of the ground surface.

Grading: Any land disturbance or land fill, or combination thereof including land development, fill material sites or demolition sites.

Improved: Altered by man-made conditions.

Land disturbance/land-disturbing activities: Any moving or-removing or filling by manual or mechanical means of the soil mantle or top six (6) inches of soil, whichever is shallower, including but not limited to excavations. Any planned disturbance of an existing land grade (fill or excavation) is considered a land disturbing activity. Prior to any modifications to existing mantle soil grade, the owner of the property must meet City requirements for grading and drainage on property modifications.

Land fill: Any human activity involving the disposition of soil, earth, or other earthen or aggregate materials.

Municipal separate storm sewer system (MS4): All natural and man-made collection and conduit facilities within the corporate limits of the city and within applicable limits of its extraterritorial jurisdiction, and for which MS4 protection the City of San Antonio has been issued a Texas Pollutant Discharge Elimination System (TPDES) Permit by TCEQ, which collection and conduit facilities constitute a system of conveyances, including but not limited to, roads with drainage systems, municipal streets, catch basins, curbs, gutters, ditches, creeks, streams, tributaries, man-made channels, or storm drains, which provide collection or conveyance of storm water, rain water, flood water, or other surface water, and may be located on public property, drainage easements, or other property, and are not designated and intended to be part of the collection system of a sanitary sewer system utilized by a publicly owned treatment works (POTW) as defined by federal regulation at 40 CFR 122.2.

NOI: Notice of intent filed by a responsible party with EPA or TCEQ. This NOI is required under state regulation for certain construction activity. The NOI is part of the state general permit process for construction activity concerning projects or runoff deemed to potentially impact waters of the State of Texas and of the United States of America.

NOT: Notice of termination. The notice required by the EPA or TCEQ for permitted projects within the jurisdiction of either agency, which notice verifies "final stabilization" of the site has been achieved, as described above; EPA form 3510-7 terminating coverage under the TPDES general permit or corresponding TCEQ form for the TPDES Texas Pollutant Discharge Elimination System general permit.

NPDES: National pollutant discharge elimination system.

Ordinance: This ordinance in its entirety, pertaining to new subdivision B, under article VI, Division 5, chapter 34, Code of Ordinances of the City of San Antonio.

Person: Any individual, partnership, co-partnership, firm, company, corporation, association, joint stock company, trust, estate, governmental entity, or any other legal entity, or the legal representatives, agents, or assigns thereof.

Pollutant: Any substance introduced into the environment that adversely affects a resource. Pollutant includes, but is not limited to, soil, soil material, sediment, human waste, other wastes and debris generated at construction sites.

Qualified Inspector: Person with credible certification or training or skills such as Certified Erosion, Sedimentation and Storm Water Inspector (CESSWI) or certified inspector of Sediment and Erosion Control (CISEC) or equal certification program or as may be required by the State of Texas that demonstrates proficiency in evaluating, interpreting and implementing Best Management Practices and elements of a Storm Water Pollution Prevention Plan (SWPPP). Additionally, a Qualified Inspector must receive a certificate of completion to the SAWS TPDES Inspector Training Workshop.

Responsible party: Any person or legal entity, individual or corporate, including an owner, operator, contractor, or subcontractor, any or all of whom may be engaged in, consent to, or actually perform a construction project or construction activity.

SAWS: The San Antonio Water System, a municipally owned utility, a co-permittee to the city's MS4 Permit and one of the city's enforcement and compliance arms for water quality, pollution control and prevention.

Sediment: Earth material deposited by water or wind.

Site: The location of construction activity, subject of this subdivision B, being within the corporate limits of the city and within the first five thousand (5,000) feet, outside such limits, within the ETJ.

Soil and/or soil material: Naturally occurring superficial deposits of earth mantle overlaying bedrock or clay; any naturally occurring surface deposit of sand, gravel, silt, clay, or any mixture thereof.

Storm water: Storm water runoff, snow melt runoff, and surface runoff and drainage, as per TPDES Permit Construction General Permit No.TXR1500000.

SWPPP: Storm Water Pollution Prevention Plan: The state or federally required plan for identifying and implementing appropriate measures to reduce pollutants in storm water discharges into the city's municipal separate storm water sewer systems (MS4), which pollutants include eroded sediments. Protective measures include, but are not limited to, natural and man-made collection components, good house-keeping for site maintenance, and other common sense actions, all frequently referred to as best management practices (BMP).

TCEQ: Texas Commission on Environmental Quality.

Unimproved: Natural conditions, unaltered.

Water Pollution Abatement Plan (WPAP): The State required plan that is described in 30 Texas Administrative Code, chapter 213 for identifying and implementing appropriate measures to reduce pollutants in Storm Water Discharges into identified sensitive areas of the Edwards Aquifer. The TCEQ TPDES Construction General Permit TXR150000, page 12, Item 5 " Discharge to the Edwards Aquifer Recharge Zone" identifies the requirement of protective measures of the Edwards Aquifer.

(Ord. No. 94002, § 1, 5-24-01; Ord. No. 2014-06-19-0472, § 1(Exh. A), 6-19-14)

Sec. 34-803. - Applicability of Subdivision B entitled "Storm Water Compliance for Construction Activity," and declaration of nuisance for violation.

Within the corporate limits of the city and within applicable limits of the city's extraterritorial jurisdiction (ETJ), no person shall perform construction activity that violates provisions of this subdivision. Construction activity in violation of this subdivision is hereby declared unlawful.

Violations committed within the corporate limits and within five thousand (5,000) feet outside the city's corporate limits shall also constitute public nuisance, as further provided below at section 34-809, Violations of any provision of this subdivision within the city's corporate limits shall be deemed a criminal Class C misdemeanor. Violations of any provision of this subdivision within the city's corporate limits or any part of the applicable ETJ shall be further subject to a civil enforcement option, more particularly described in section 34-808 (b) below.

Some of the requirements of this subdivision may be generally characterized as good house-keeping protocols, those expected to be employed by a reasonably prudent contractor, operator, owner, or other person having responsibilities for various activities on a construction site. Where state or federal permits require the site operator, owner, or other responsible party, to make a storm water pollution prevention plan (SWPPP), such plans must be readily available on the site for city inspection.

(Ord. No. 94002, § 1, 5-24-01; Ord. No. 2014-06-19-0472, § 1(Exh. A), 6-19-14)

Sec. 34-804. - General prohibition against construction pollution of the municipal separate storm sewer; measurable volumes for violation; required TCEQ TPDES permit; SWPPP and WPAP (as applicable).

- (a) It is unlawful for any person to engage in construction activity which activity results in a measurable volume of sediment, soils, soils material, or pollutants entering the city's municipal separate storm sewer system (MS4).
- (b) "Measurable volume" of sediment, soil, soil material, or pollutant, for purposes of determining a violation, shall be such volume as is capable of being truly and correctly depicted in a photograph, motion picture, or video recording of the sediment, soil, soil material, or pollutant in question.
- (c) Nothing in this section shall diminish or change the general prohibitions against MS4 pollution found in section 34-702, subdivision A, Division 5, of this chapter 34, Prohibited discharges into the municipal separate storm sewer system. SAWS shall continue to exercise all enforcement powers set out in this chapter 34, and to gather such evidence as may include, but not be limited to, samples and analysis appropriate to enforcement of chapter 34 provisions.
- (d) The responsible party shall use best management practices (BMP) to prevent sediment, soils, soils materials, and pollutants from entering the city's MS4.
- (e)

It is unlawful for any person to engage in construction activity without employing BMP necessary to protect the city's MS4 from run-off or other media capable of transporting sediment, soil, soil material, and pollutants into the city's MS4.

- (f) The responsible party shall post at the main entrance of the site all operator notices including without limitation, such as notice of construction, construction site notice, contact information and WPAP notice of construction (as examples).
- (g) Portions of the Edwards Aquifer Recharge Zone and Edwards Aquifer Contributing Zone within the city extraterritorial jurisdiction shall be considered inclusive in this section.
- (h) The operator shall have available and maintain on the construction site a copy of the SWPPP and where applicable, the WPAP.
- (i) It is unlawful for any person to engage in construction activity without a complete SWPPP (as defined in TCEQ TXR 150000 or WPAP (as applicable) available on the construction site

(Ord. No. 94002, § 1, 5-24-01; Ord. No. 2014-06-19-0472, § 1(Exh. A), 6-19-14)

Sec. 34-805. - Additional federal and state requirements generally applicable to responsible parties associated with TPDES Regulated Projects: proper custody of federal or state storm water pollution prevention plans (SWPPP); applicable to parties required to provide TPDES notice of intent (NOI) or Small Construction Site Notice (CSN) to EPA or TCEQ and San Antonio Water System (SAWS); requirement to post TPDES Notices at site; requirement to make SWPPP available to city inspector; copy of Notice of Termination (NOT) or small construction site or large construction site secondary operator completed site notices required by TCEQ or SAWS.

- (a) Concerning projects for which the EPA or TCEQ or the City have permitting authority, the responsible party shall post at the site, as required by federal or state regulations, a true and correct copy of the NOI, Permit Number, large construction site notice or small construction site notice. A copy of the NOI, Permit number, large construction site notice or small construction site notice and the WPAP Notice of construction shall also be sent to SAWS resource protection and compliance department at the same time it is sent to EPA or TCEQ when applicable.
- (b) The responsible party shall have available for city inspection, on site, the storm water pollution prevention plan (SWPPP) imposed by EPA or TCEQ, when the site in question is subject to such plans imposed by federal or state law.

- (c) The responsible party shall make the SWPPP available to the city inspector, on reasonable request made during normal working hours.
- (d) Failure, refusal, or inability to provide such plan for inspection, when the plan is required under state or federal law, constitutes a violation of this subdivision.
- (e) It shall be unlawful for any person to engage in construction activity in violation of the elements of an applicable SWPPP and applicable WPAP.
- (f) The responsible party shall provide SAWS a true and correct copy of any notice of termination (NOT), small construction site completed site notice or large construction site secondary operator completed site notice necessary to close out a project regulated by EPA or TCEQ. This copy shall be sent to SAWS, to the attention of SAWS resource protection and compliance department, at the time it is sent to EPA or TCEQ.
- (g) Where permanent improvements have been constructed, the final inspection shall verify whether or not the "final stabilization" criteria have been met.
- (h) Where no permanent improvements are planned, temporary BMPs shall continue to be maintained until site has reached final stabilization.
- (i) A site shall continue to be regulated and maintain an open, active permit until final stabilization is achieved; and, where applicable to state and federally regulated sites, until a "notice of termination" (NOT) or small construction site completed site notice or large construction site secondary operator completed site notice has been filed. A copy of the NOT, if applicable, will also be filed with the SAWS as described above at subsection (t).
- (k) Where the site has met final stabilization requirements, but the controls or measures implemented thereafter fail, each discharge of construction related contamination by the responsible party shall constitute a violation of this subdivision B.
- (l) Removal of temporary BMPs shall be required after the site achieves final stabilization.
- (m) The responsible party shall have available for City inspection on the construction site, a true copy of an approved master plan of development.
- (n) The responsible party shall have available on the construction site the water pollution abatement plan (WPAP) and WPAP approval notice imposed by TCEQ when the site in question is subject to such plans required by TCEQ in 30 Texas Administrative Code, Chapter 213.

- (o) The responsible party shall have available for city inspection all records and documents required by the EPA or TCEQ SWPPP and TCEQ WPAP (as applicable).
- (p) All SWPPP documents shall be designed and signed by a licensed professional engineer (Texas) with competence in this area as required by Texas Engineering Practice Act, Section 137, or a certified professional in erosion and sedimentation control (CPESC), or other registered/certified professional with competence in this area (such as a landscape architect) or as required by the State of Texas TCEQ.
- (q) To assure continued effective compliance with best management practice methodology on the construction/development site, the owner and/or engineer or certified inspector such as CPESC, certified erosion, sediment and storm water inspector (CESSWI) or certified inspector of sediment and erosion control (CISEC) or other equal certification as may be required by the State of Texas, (hereafter referred to as owner's representative) shall conduct ongoing inspections of all erosion/sedimentation controls and direct the person or firm responsible for maintenance to make any repairs or modifications necessary within 48 hours of the initial notification.

(Ord. No. 94002, § 1, 5-24-01; Ord. No. 2014-06-19-0472, § 1(Exh. A), 6-19-14)

Sec. 34-806. - Best management practices (BMP) guidelines; compliance with this subdivision should not be relied upon by the regulated community to automatically effect compliance with what may be more stringent federal or state regulations pertaining to EPA/TNRCC TCEQ permitted construction sites; explanation of federal jurisdiction.

- (a) BMP applications recommended to responsible parties are those techniques described in TCEQ's "Technical Guidance on Best Management Practices," document no. RG-348, Revised July- 2005, as such document may be updated and revised, or when available, the city's technical guidance manual for construction activity.
- (b) Responsible parties are advised that the city's recognition of BMP and other good house-keeping protocols are not necessarily synonymous with federal standards directly associated with EPA's construction general permit for other construction sites regulated under federal law or the TCEQ's construction general permit. Some sites will be federally regulated construction sites while most construction sites will be permitted by the State of Texas under guidelines similar to those of EPA. Responsible parties whose projects of scale fall within state or federal parameters

are responsible to EPA or TCEQ to fulfill requirements that may differ from or may be more stringent than the provisions of this article applying to local, individual construction sites of a scale not regulated by state or federal authorities.

- (c) In contrast, the purpose of this subdivision and its requirements for BMP are to satisfy the city's own state permit which specifically requires the city to adopt a construction site regulation. Consequently, the intent of this subdivision is to protect MS4 from pollutants generated from local construction sites. Federal and state jurisdiction to support this directive is found in the conduit of urban runoff traversing the San Antonio area into rivers, streams, and especially bays regulated as "waters of the United States of America" and "waters of the State of Texas". Hence, storm water generated in the area of San Antonio may enter into and impact state and federal waters.

(Ord. No. 94002, § 1, 5-24-01; Ord. No. 2014-06-19-0472, § 1(Exh. A), 6-19-14)

Sec. 34-807. - Enforcement procedures.

- (a) The director of public works may designate additional field enforcement staff to supplement SAWS resource protection and compliance department staff, here designated and referred to above and hereafter as city inspectors (inspectors).
- (b) Upon observation of an alleged violation or condition an inspector believes constitutes a violation of this subdivision, the inspector shall issue a field correction notice (FCN) to a responsible party. The field correction notice shall be personally delivered to a responsible party, if such person is available on site; or, in the absence of such person, shall be posted at the construction site and mailed by U.S. Mail or by electronic e-mail. Field correction notices shall afford two (2) 24-hour periods to correct the violation alleged. The first 24-hour period should be used to remediate and remove the offending material, if any, from the city's MS4, or obtain and post permit documents and/or provide a copy of a complete SWPPP and WPAP (as applicable). A second 24-hour grace period shall follow immediately to allow the responsible party to appropriately install or repair corrective BMP which was lacking or failed to protect city property.
- (c) If the violation is cured within forty-eight (48) hours, as described above, no further city action is required.
- (d) If correction is not made timely, the inspector may issue a stop work order.
- (e)

If a stop work order is not honored at the site and/or corrective action is not timely accomplished to protect the city's MS4, citations may be issued or civil injunctive remedies with appropriate penalties may be pursued.

- (f) Additional or cumulative enforcement action may be taken as the seriousness of the alleged pollutant encroachment in the MS4 may warrant.
- (g) Additional compliance time may be afforded, if within the judgment and discretion of the inspector, municipal obligations to environmental health and safety and municipal stormwater compliance obligations to enforcement agencies are not compromised.
- (h) Upon observation of an alleged violation or condition an inspector believes constitutes a violation of a water pollution abatement plan within the Edwards Aquifer Recharge Zone, the inspector shall have the authority to issue a field correction notice (FCN) to a responsible party. Delivery of the FCN shall be in accordance with the process as identified in paragraph (b) of this section. The field correction notice shall require immediate correction of the violation alleged or within 24 hours of observation of alleged violation as specified and documented by the inspector on the FCN. If correction is not made timely, the inspector may issue a Stop Work Order.

(Ord. No. 94002, § 1, 5-24-01; Ord. No. 2014-06-19-0472, § 1(Exh. A), 6-19-14)

Sec. 34-808. - Criminal and civil enforcement.

- (a) A penalty is hereby established whereby any person who shall violate any provision of this subdivision shall be deemed to be guilty of a misdemeanor and shall upon conviction be fined a minimum amount of not less than two hundred dollars (\$200.00) per violation and a maximum amount of not more than two thousand dollars (\$2,000.00) per violation. Each day of violation shall constitute a separate offense for purposes of the enforcement of this subdivision.
- (b) The city attorney has authority to pursue all legal, equitable, and criminal remedies appropriate to enforce all provisions of this subdivision, including, but not limited to, authority under the Texas Local Government Code, chapter 54, providing for injunctive relief and court imposed civil penalties up to five thousand dollars (\$5,000.00) a day for violation of ordinances relating to discharge of a pollutant into a storm sewer system controlled by a municipality.
- (c)

Upon the written direction of the director of public works, advising of an alleged violation of any section of this subdivision, the city attorney, pursuant to subsection (d) above, is authorized to petition any court of competent jurisdiction for an injunction to enjoin the continuance of such violation and to secure any and all civil penalties within the jurisdiction of the appropriate court. This remedy shall be cumulative of and to all other enforcement remedies available to the city.

- (d) The authority set out above shall in no way diminish the authority and responsibility of the city attorney to diligently prosecute violations of this subdivision through the municipal prosecutor's office.
- (e) The SAWS is a co-permittee, under the federal permit, and a contractual enforcement arm of the city. In consultation with the city attorney, SAWS legal officers may exercise all or specific enforcement options enumerated in this subdivision B on behalf of the city.

(Ord. No. 94002, § 1, 5-24-01; Ord. No. 2014-06-19-0472, § 1(Exh. A), 6-19-14)

Sec. 34-809. - Declaration of nuisance within applicable limits of the city's ETJ; city's authority to enforce within five thousand (5,000) feet outside the city limits.

Under authority of the Texas Local Government Code, section 217.042 (a) (b), noncompliance with provisions of this subdivision B, or violation of its provisions, is here declared a nuisance and by authority of the enabling statute such declaration of nuisance extends to and shall be applicable within both the corporate limits of the city and within five thousand (5,000) feet outside the limits. Accordingly, summary abatement authority rests in the city's enforcement officials when imminent threat to the public health, safety, or welfare may arise.

(Ord. No. 94002, § 1, 5-24-01; Ord. No. 2014-06-19-0472, § 1(Exh. A), 6-19-14)

Secs. 34-810—34-849. - Reserved.

Subdivision C. - Storm Water Compliance for Industrial and Commercial Activities^[15]

Sec. 34-850. - General provisions.

(1)

Purpose. This subdivision sets forth requirements for all facilities discharging to the San Antonio Municipal Separate Storm Sewer System (MS4) and those facilities required maintain a Texas Pollutant Discharge Elimination System (TPDES) Multi-Sector General Permit (MSGP) for Industrial Storm Water Discharges.

- (2) *Administration.* Pursuant to the TPDES Permit No. WQ0004284000 issued to the City of San Antonio, San Antonio Water System (SAWS) and the Texas Department of Transportation requiring the establishment of an Industrial and High Risk Runoff Program SAWS shall have responsibility for administering, implementing, and enforcing the Industrial Inspection Program as outlined in the San Antonio Storm Water Management Plan and established by this subdivision.
- (3) *Objectives:* The objective of this subdivision is to prevent the introduction of pollutants to the maximum extent practicable into the MS4 from industrial and/or commercial facilities, including but not limited to those regulated categories that must maintain a TPDES discharge permit. All facilities that discharge storm water defined as being "associated with industrial activity" under provisions of Section 402 of the Clean Water Act and Chapter 26 of the Texas Water Code that discharge directly to waters of the state, the United States, or through a municipal separate storm sewer system are required to obtain either a MSGP or obtain a conditional No Exposure Exclusion (NEC) from permit requirements from the TCEQ.

(Ord. No. 2014-06-19-0472, § 1(Exh. A), 6-19-14)

Sec. 34-851. - MSGP permit required.

The following facilities are required to obtain MSGP permit coverage and provide a copy to SAWS:

- (a) Those facilities operating under the Industrial Sectors of the MSGP, and
- (b) SAWS may require that an industrial or commercial facility not specifically referenced by the North American Industry Classification System to comply with SWP3 requirements of the MSGP in order to control to the maximum extent practicable the discharge of pollutants of concern into the MS4.

(Ord. No. 2014-06-19-0472, § 1(Exh. A), 6-19-14)

Sec. 34-852. - Conditional no exposure certification.

Facilities regulated under the industrial activities described by one or more sectors of the MSGP may be excluded from permit requirements if there is no exposure of industrial materials or activities to precipitation or runoff. To qualify for this conditional exclusion from permit requirements, the operator must apply to the TCEQ for the NEC permit exclusion and provide certification that those regulated industrial activities and materials mobilized by storm water are isolated from storm water and storm water runoff by storm resistant shelters (as defined in the MSGP). Facilities that qualify for this exclusion shall provide a copy of the NEC to SAWS upon request. Facilities that operate under a conditional NEC exclusion are subject to inspection to verify compliance. Facilities that previously qualified for a NEC and have made changes in their industrial process resulting in exposure must obtain a MSGP to discharge storm water associated with industrial activities.

(Ord. No. 2014-06-19-0472, § 1(Exh. A), 6-19-14)

Sec. 34-853. - Storm water pollution prevention plan requirements.

- (1) SWP3 Components. Each facility requiring a MSGP Permit shall develop and implement a Storm Water Pollution Prevention Plan (SWP3) prior to submitting a Notice of Intent to the TCEQ for MSGP permit coverage. The SWP3 must be maintained onsite or made readily available for review by SAWS upon request. The SWP3 shall include all elements identified in the MSGP language and continuously meet the criteria including any SWP3 updates and Best Management Practices (BMPs) maintenance as necessary to control discharge of pollutants. The SWP3 shall be developed to identify actual and potential sources of pollution that may reasonably be expected to affect the quality of storm water discharges from the facility. The SWP3 shall establish BMPs and any necessary structural control necessary to reduce or eliminate pollutants from the facility's storm water discharge. The SWP3 shall describe how such practices are appropriate for the facility and how each will effectively prevent or lessen pollution.
- (2) Sampling criteria. Each regulated facility shall take the appropriate samples at the frequency prescribed in the current MSGP. These storm water samples include but are not limited to: effluent limitations for hazardous metals, benchmark sampling and any sector specific sampling required under the MSGP.
- (3)

Industrial and/or commercial facilities determined to potentially contribute pollutant loading to the MS4 may be required to perform additional monitoring as outlined by the TCEQ Municipal TPDES Permit to validate improvements to the BMPs and changes in the SWP3. This additional sampling can include, but is not limited to:

- Any pollutant limited in an existing TPDES permit for the facility
- Oil and Grease (O/G)
- Chemical Oxygen Demand (COD)
- pH
- Biochemical Oxygen Demand (BOD5)
- Total Suspended Solids (TSS)
- Phosphorus (P)
- Total Kjeldahl Nitrogen (TKN)
- Nitrate plus Nitrite Nitrogen
- Ammonia-nitrogen
- Temperature
- Total Organic Carbon (TOC)
- E. Coli and Fecal Coliform

(4) The SWP3 and monitoring data must be submitted to SAWS upon request.

(Ord. No. 2014-06-19-0472, § 1(Exh. A), 6-19-14)

Sec. 34-854. - Inspection and entry.

SAWS shall have the right to inspect the facilities of any industrial user to ascertain whether the purposes of this subdivision are being met and all applicable requirements are being fulfilled. Industrial users and their employees shall allow SAWS representatives displaying proper identification ready access to the premises at all reasonable times for the purpose of: inspecting industrial operations and processes, examination and reproduction of business records pertinent to storm water quality, including hazardous and non-hazardous waste manifests and where applicable, making photographic documentation and obtaining other information necessary to ascertain whether the information submitted is current, and to assess compliance by permittees with storm water permit requirements. Failure to allow access or impeding an investigation will be considered a violation of this subdivision. In the event SAWS reasonably believes discharges

from a property into the MS4 may cause an imminent and substantial threat to human health or the environment, an inspection may take place at any time without notice to the owner of the property or a representative on-site.

(Ord. No. 2014-06-19-0472, § 1(Exh. A), 6-19-14)

Sec. 34-855. - Falsifying information.

- (1) It is a violation of this subdivision to knowingly make any false statement, representation or certification in any application, record, report, plan, or other document filed or required to be maintained pursuant to this subdivision or pursuant to any condition or provision of an industrial storm water discharge permit.
- (2) It is a violation of this subdivision to tamper with, interfere with the operation of, or knowingly render inoperable any monitoring, sampling or surveillance devices or to improperly impede an inspection procedure required or authorized under this subdivision and/or any industrial discharge permit. In addition to any civil or criminal liability that may be imposed for a violation of this subdivision, a person who damages equipment used or necessary for monitoring compliance with an industrial discharge permit and/or this subdivision, shall also be liable for the cost associated with replacing or repairing such equipment.

(Ord. No. 2014-06-19-0472, § 1(Exh. A), 6-19-14)

Sec. 34-856. - Enforcement and penalties.

- (1) *Violations.* The commission of any act that is prohibited by this subdivision or the failure to perform any act that is required by this subdivision is a violation of this subdivision. SAWS may require that a compliance meeting be held prior to implementing legal action to enforce the provisions of this subdivision; however, such a meeting shall not be a bar against or a prerequisite for taking any enforcement action.
- (2) *Penalties for violations.*
 - (a)

Criminal. A conviction for a violation of this subdivision shall constitute a Class C misdemeanor. A person convicted of a violation of this subdivision shall be fined a minimum amount of not less than two hundred dollars (\$200.00) per violation and a maximum amount of not more than two thousand dollars (\$2,000.00) per violation.

Each violation of this subdivision shall constitute a separate offense, and each day an offense continues shall be considered a new violation for purposes of enforcing this subdivision.

(b) *Civil.* A civil penalty in an amount not to exceed five thousand dollars (\$5,000.00) per violation of this subdivision may be imposed. Each violation of this subdivision shall constitute a separate violation, and each day such violation continues shall be considered a new violation for purposes of enforcing this subdivision, and calculating the amount of civil penalties.

(3) *Additional remedies.* In addition to the penalties for violations that may be imposed pursuant to this subdivision, SAWS may commence actions for any other legal and/or equitable relief or for the imposition of civil penalties authorized by any applicable law, statute, ordinance, or regulation.

(Ord. No. 2014-06-19-0472, § 1(Exh. A), 6-19-14)

AN ORDINANCE **20 14 - 0 6 - 1 9 - 0 4 7 2**

AMENDING CHAPTER 34, ARTICLE III, DIVISION 4; ARTICLE V, DIVISIONS 3 AND 5; AND ARTICLE VI, DIVISIONS 2 AND 3 OF THE SAN ANTONIO CITY CODE FOR THE PURPOSE OF UPDATING PROGRAM REQUIREMENTS TO REDUCE OR ELIMINATE THE DISCHARGE OF HARMFUL POLLUTANTS INTO THE SAWS SANITARY SEWER SYSTEM AND THE CITY'S STORM WATER SYSTEM IN COMPLIANCE WITH CURRENT STATE AND FEDERAL REGULATIONS.

* * * * *

WHEREAS, the federal Clean Water Act (33 U.S.C §§1251, et. seq.) includes regulations applicable to publicly owned treatment works (POTWs) which are administered by the United States Environmental Protection Agency (EPA) (40 C.F.R. Pts. 403 and 122) implementing the National Pollutants Discharge Elimination System (NPDES); and

WHEREAS, POTWs collect domestic sources of wastewater from homes, commercial buildings, and industrial facilities and transport it via collection pipes to treatment plants in order to remove harmful organisms and other contaminants from the sewer sludge so it can be discharged safely into receiving streams and rivers; and

WHEREAS, POTWs also receive nondomestic wastewater from industrial users (IUs) which may pass through or interfere with the treatment process and contaminate sewer sludge; and

WHEREAS, the EPA has established the National Pretreatment Program as part of the NPDES regulations outlining responsibilities of federal, state, and local governments to implement Pretreatment Standards applicable to IUs to control nondomestic industrial pollutants that may contaminate sewer effluent discharged into streams and rivers; and

WHEREAS, the objectives of the National Pretreatment Program are achieved by applying and enforcing three types of discharge standards:

- Prohibited Discharge Standards – prohibit the discharge of any industrial pollutants to a POTW that cause pass through or interfere with the sewer treatment process.
- Categorical Pretreatment Standards – limit industrial pollutants discharged in wastewater to the POTW from specific industrial categories.
- Local Limits – prohibit the discharge of specific industrial pollutants based on the specific needs and capabilities of the POTW.

WHEREAS, the Texas Commission on Environmental Quality (TCEQ) is charged with administration of the Texas Pollutant Discharge Elimination System (TPDES) pursuant to Texas Water Code – Chapter 26 (TCEQ general regulatory authority), 30 T.A.C. Chapter 315 (implementation of EPA Pretreatment Program), and Texas Health & Safety Code – Chapter 361 and 30 T.A.C. Chapter 312 (Implementation of EPA Sewer Sludge Program).

WHEREAS the San Antonio Water System (SAWS) sanitary sewer system and the City of San Antonio (City) storm water system are separate qualifying POTWs subject to the National Pretreatment Program as implemented by the EPA and TCEQ; and

WHEREAS, the City's storm water system is managed by the Transportation and Capital Improvements Department (TCI) which is assisted by SAWS in meeting regulatory compliance requirements associated with its Municipal Separate Storm System (MS4) Program; and

WHEREAS, there is a need and desire to update local storm water and sewer environmental protection regulations found in Chapter 34 of the City Code in order to bring them into compliance with the National Pretreatment Program based on current state and federal standards; and

WHEREAS, SAWS and TCI staff recommend updates to Chapter 34 of the San Antonio City Code as follows:

1. Article III, Division 4 – Rates and Charges
 - o Clarification to Industrial Waste Surcharge Formula
2. Article V, Division 3 – Industrial Waste
 - o Incorporating TCEQ pretreatment regulations and updating the Industrial Waste permitting program to incorporate the changes
3. Article V, Division 5 – Fats, Oils and Grease
 - o Correct reference to Chapter 10 of the Plumbing Code
 - o Allows for correct disposal of Grease trap waste from self-cleaning for interceptors with a capacity of less than 100 gallons
4. Article VI, Division 5 Subdivision B – Storm Water Compliance for Construction Activity
 - o Incorporates changes to the TCEQ Construction General Permit
 - Updates language to cover construction projects 1 acre and larger or part of a planned development and includes fill sites under the definition requiring incorporation of Best Management Practices to control erosion
 - Updates requirements for development of Storm Water Pollution Prevention Plans
 - Updates requirements for inspection of projects
 - Incorporates efficiencies to streamline inspections of sites that have both storm water requirements and are located over the EARZ and subject to Water Pollution Abatement Plans
5. Article VI, Division 5 subdivision C – Storm Water Compliance for Industrial & Commercial activities
 - o Incorporates an addition Subdivision to regulate Industrial facilities under TCEQ Multi-sector Industrial Storm Water permit
6. Article VI, Division 2 -Wells
 - o Corrects water well permit fees to reflect the current charges
 - o Adds definitions to provide clarifications
 - o Adds an expiration date for water well drilling permits

NOW THEREFORE, BE IT ORDAINED BY THE CITY COUNCIL OF THE CITY OF SAN ANTONIO:

SECTION 1. The amendments to Chapter 34, Article III, Division 4; Article V, Divisions 3 and 5; and Article IV, Divisions 2 and 5 of the San Antonio Municipal Code attached as Exhibit A, are hereby approved, adopted, and incorporated into this Ordinance for all purposes.

SECTION 2. The City Council directs the City Clerk to amend the City Code as authorized in this Ordinance by submitting the revised Chapter 34 provisions to the Municipal Code Corporation as attached in **Exhibit A**.

SECTION 3. The recitals set out above are fully incorporated into this Ordinance.

SECTION 4. This Ordinance shall become effective immediately upon the passage by eight (8) votes of the City Council and if passed upon fewer than eight (8) votes after the tenth (10th) day after passage. The revisions to Chapter 34 of the San Antonio Municipal Code, as found in Exhibit A, will become effective upon passage of this Ordinance.

PASSED AND APPROVED, this 19th day of June, 2014.



M A Y O R
Julian Castro

ATTEST:

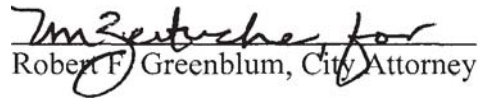

Leticia M. Vacek, City Clerk

APPROVED AS TO FORM:



Robert F. Greenblum, City Attorney

Agenda Item:	37 (in consent vote: 6, 7, 8, 9, 10, 11, 12, 13, 14, 16, 18, 19, 20, 21, 24, 27, 28, 29, 30, 31, 32, 35, 36, 37, 38A, 38B, 39A, 39B, 40A, 40B, 40C)
Date:	06/19/2014
Time:	10:29:56 AM
Vote Type:	Motion to Approve
Description:	An Ordinance updating Chapter 34 of the City Code (Water & Sewer) so that management of the City's Sanitary Sewer and Storm Water System continues to be in compliance with the Federal Clean Water Act and the Texas Commission on Environmental Quality requirements. [Peter Zaroni, Deputy City Manager; Mike Frisbie, Director, Transportation and Capital Improvements]
Result:	Passed

Voter	Group	Not Present	Yea	Nay	Abstain	Motion	Second
Julian Castro	Mayor		x				
Diego Bernal	District 1		x				
Ivy R. Taylor	District 2		x				
Rebecca Viagran	District 3		x				
Rey Saldana	District 4		x				
Shirley Gonzales	District 5		x				
Ray Lopez	District 6		x				x
Cris Medina	District 7		x				
Ron Nirenberg	District 8		x			x	
Joe Krier	District 9		x				
Michael Gallagher	District 10		x				

PART II- CODE
Chapter 34- WATER AND SEWERS
ARTICLE VI. - WATER QUALITY CONTROL AND POLLUTION PREVENTION
DIVISION 5. - PROHIBITED DISCHARGES INTO THE MUNICIPAL SEPARATE STORM SEWER SYSTEM

Subdivision B. - Stormwater Compliance for Construction Activity

Sec. 34-801. - Statement of purpose.

Sec. 34-802. - Definitions.

Sec. 34-803. - Applicability of Subdivision B entitled "Storm Water Compliance for Construction Activity," and declaration of nuisance for violation; no culpable mental state required.

Sec. 34-804. - General prohibition against construction pollution of the municipal separate storm sewer; measurable volumes for violation.

Sec. 34-805. - Additional federal and state requirements generally applicable to responsible parties associated with one (1) acre or larger projects: proper custody of federal or state storm water pollution prevention plans (SWPPP); applicable to parties required to provide notice of intent (NOI) to EPA or TCEQ; requirement to post NOI at site; requirement to make SWPPP and WPAP (as applicable) available to city inspector; copy of notice of termination required by EPA or TCEQ.

Sec. 34-806. - Best management practices (BMP) guidelines; compliance with this subdivision should not be relied upon by the regulated community to automatically effect compliance with what may be more stringent federal or state regulations pertaining to EPA/ TCEQ permitted construction sites; explanation of federal jurisdiction.

Sec. 34-807. - Enforcement procedures.

Sec. 34-808. - Criminal and civil enforcement.

Sec. 34-809. - Declaration of nuisance within applicable limits of the city's ETJ; city's authority to enforce within five thousand (5,000) feet outside the city limits.

Secs. 34-810-34-900. - Reserved.

Sec. 34-801. - Statement of purpose.

The intent of the ordinance from which this subdivision derives, creating subdivision B, is to satisfy conditions imposed by the City's Texas Pollutant Discharge Elimination System (TPDES) Permit issued by the Texas Commission on Environmental Quality (TCEQ).

All construction addressed by the ordinance from which this subdivision derives is intended to conform to Best Management Practices. Applicable Best Management Practices (BMP) are presently outlined in the Texas Commission on Environmental Quality (TCEQ) Technical Guidance On Best Management Practices, June 1999, Document No. RG-348 (Revised July 2005). The TCEQ guidance may be updated by the agency or revised by the City of San Antonio for integration into the City's technical guidance manual for local construction activity. All these sources are merely recommended guidance and examples for responsible parties. Choice of techniques is at the option of the responsible party.

(Ord. No. 94002, § 1, 5-24-01)

PART II-CODE

Chapter 34 - WATER AND SEWERS

ARTICLE VI. - WATER QUALITY CONTROL AND POLLUTION PREVENTION

DIVISION 5. - PROHIBITED DISCHARGES INTO THE MUNICIPAL SEPARATE STORM SEWER SYSTEM

Sec. 34-802. - Definitions.

When used in this Subdivision B, the following terms shall have the following meanings:

Best Management Practices (BMP): A technique or series of structural and non-structural techniques and practices which, when used in an erosion control plan or considered as part of a construction site's housekeeping efforts, are proven to be effective in controlling construction-related runoff, erosion, sedimentation, and associated pollutants. Applicable BMP's can be found in TCEQ approved BMP Guidance manuals.

Construction activity: Clearing, grading or filling of land, dozing or mechanical removal of trees which dozing or mechanical removal disturbs the soil, excavation for installation of utility lines, streets, drainage facilities, and site preparation for housing and commercial development, as well as on-going construction activities which produce waste products. Land being modified by either excavation or fill of material upon an existing mantle of soils is considered a construction activity and subject to the terms of this Ordinance unless otherwise permitted under a Multi-sector Industrial Storm Water Permit. Prior to any modification to an existing mantle soil grade the owner of the property must meet City requirements for grading and drainage applicable to property modifications.

Director of public works: The Director of Public Works of the City of San Antonio, including his/her designees.

EPA: The United States Environmental Protection Agency.

Erosion: the wearing away of the ground surface as a result of the movement of wind, water and/or ice.

Extraterritorial jurisdiction (ETJ): The un-incorporated area contiguous to corporate boundaries of the city that is located within five (5) miles of those boundaries, defined by the Texas Local Government Code and as such Code may be amended. Applicable limits of the ETJ, for enforcement purposes of this subdivision, are only those areas within the first five thousand (5,000) feet of San Antonio's corporate boundaries within the ETJ.

Final inspection: Occurs after responsible party meets definition of final stabilization and files a Notice of Termination (NOT) form, if required by state or federal law, at which time SAWS will conduct a final inspection to verify both compliance with final stabilization and removal of the temporary BMP's from the site has occurred. Final inspections will be required at both small Construction Sites and Large Construction Sites. Secondary Operators are required to complete Site Notices and complete a NOT form as required under the TPDES permit.

Final stabilization: Reference to standards in the TCEQ TPDES General Permit for Storm Water Discharges for Construction Activities concerning development acreage that: (1) where state or federally regulated development acreage is concerned, all soil disturbing activities at the site have been completed, and a uniform perennial vegetative cover, with a density of seventy (70) percent of the native background vegetative cover for the area has been established on all unpaved areas and areas not covered by permanent structures or equivalent permanent stabilization measures have been employed and (2) where local, individual lots associated with residential or commercial construction are concerned, by

PART II- CODE

Chapter 34- WATER AND SEWERS

ARTICLE VI. - WATER QUALITY CONTROL AND POLLUTION PREVENTION

DIVISION 5. - PROHIBITED DISCHARGES INTO THE MUNICIPAL SEPARATE STORM SEWER SYSTEM

either (a) the responsible party complying with cover requirements guided by federal or state standards recited above, or (b) the responsible party establishing temporary stabilization including perimeter controls and informing the home buyer or commercial purchaser in writing of the need for and benefits of final stabilization.

Grade: The vertical location of the ground surface.

Grading: Any land disturbance or land fill, or combination thereof including land development, fill material sites or demolition sites.

Improved: Altered by man-made conditions.

Land disturbance/land-disturbing activities: Any moving or removing or filling by manual or mechanical means of the soil mantle or top six (6) inches of soil, whichever is shallower, including but not limited to excavations. Any planned disturbance of an existing land grade (fill or excavation) is considered a land disturbing activity. Prior to any modifications to existing mantle soil grade, the owner of the property must meet City requirements for grading and drainage on property modifications.

Land fill: Any human activity involving the disposition of soil, earth, or other earthen or aggregate materials.

Municipal separate storm sewer system (MS4): All natural and man-made collection and conduit facilities within the corporate limits of the City of San Antonio and within applicable limits of its extraterritorial jurisdiction, and for which MS4 protection the City of San Antonio has been issued a Texas Pollutant Discharge Elimination System (TPDES) Permit by TCEQ, which collection and conduit facilities constitute a system of conveyances, including but not limited to, roads with drainage systems, municipal streets, catch basins, curbs, gutters, ditches, creeks, streams, tributaries, man-made channels, or storm drains, which provide collection or conveyance of storm water, rain water, flood water, or other surface water, and may be located on public property, drainage easements, or other property, and are not designated and intended to be part of the collection system of a sanitary sewer system utilized by a publicly owned treatment works (POTW) as defined by federal regulation at 40 CFR 122.2.

NOI: Notice of intent filed by a responsible party with EPA or TCEQ. This NOI is required under state regulation for certain construction activity. The NOI is part of the state general permit process for construction activity concerning projects or runoff deemed to potentially impact waters of the State of Texas and of the United States of America.

NOT: Notice of termination. The notice required by the EPA or TCEQ for permitted projects within the jurisdiction of either agency, which notice verifies "final stabilization" of the site has been achieved, as described above; EPA form 3510-7 terminating coverage under the TPDES general permit or corresponding TCEQ form for the TPDES Texas Pollutant Discharge Elimination System general permit.

NPDES: National pollutant discharge elimination system.

Ordinance: This ordinance in its entirety, pertaining to new Subdivision B, under Article VI, Division 5,

PART II-CODE

Chapter 34 - WATER AND SEWERS

ARTICLE VI. - WATER QUALITY CONTROL AND POLLUTION PREVENTION

DIVISION 5. - PROHIBITED DISCHARGES INTO THE MUNICIPAL SEPARATE STORM SEWER SYSTEM

Chapter 34, Code of Ordinances of the City of San Antonio.

Person: Any individual, partnership, co-partnership, firm, company, corporation, association, joint stock company, trust, estate, governmental entity, or any other legal entity, or the legal representatives, agents, or assigns thereof.

Pollutant: Any substance introduced into the environment that adversely affects a resource. Pollutant includes, but is not limited to, soil, soil material, sediment, human waste, other wastes and debris generated at construction sites.

Qualified Inspector: Person with credible certification or training or skills such as Certified Erosion, Sedimentation and Storm Water Inspector (CESSWI) or Certified Inspector of Sediment and Erosion Control (CISEC) or equal certification program or as may be required by the State of Texas that demonstrates proficiency in evaluating, interpreting and implementing Best Management Practices and elements of a Storm Water Pollution Prevention Plan (SWPPP). Additionally, a Qualified Inspector must receive a certificate of completion to the SAWS TPDES Inspector Training Workshop.

Responsible party: Any person or legal entity, individual or corporate, including an owner, operator, contractor, or subcontractor, any or all of whom may be engaged in, consent to, or actually perform a construction project or construction activity.

SAWS: The San Antonio Water System, a municipally owned utility, a co-permittee to the City's MS4 Permit and one of the city's enforcement and compliance arms for water quality, pollution control and prevention.

Sediment: Earth material deposited by water or wind.

Site: The location of construction activity, subject of this Subdivision B, being within the corporate limits of the city and within the first five thousand (5,000) feet, outside such limits, within the ETJ.

Soil and/or soil material: Naturally occurring superficial deposits of earth mantle overlaying bedrock or clay; any naturally occurring surface deposit of sand, gravel, silt, clay, or any mixture thereof.

Storm water: Storm water runoff, snow melt runoff, and surface runoff and drainage, as per TPDES Permit Construction General Permit No. TXR1500000.

SWPPP: Storm Water Pollution Prevention Plan: The state or federally required plan for identifying and implementing appropriate measures to reduce pollutants in storm water discharges into the city's municipal separate storm water sewer systems (MS4), which pollutants include eroded sediments. Protective measures include, but are not limited to, natural and man-made collection components, good house-keeping for site maintenance, and other common sense actions, all frequently referred to as best management practices (BMP).

TCEQ: Texas Commission on Environmental Quality.

Unimproved: Natural conditions, unaltered.

PART II- CODE

Chapter 34- WATER AND SEWERS

ARTICLE VI. - WATER QUALITY CONTROL AND POLLUTION PREVENTION

DIVISION 5. - PROHIBITED DISCHARGES INTO THE MUNICIPAL SEPARATE STORM SEWER SYSTEM

Water Pollution Abatement Plan (WPAP): The State required plan that is described in 30 Texas Administrative Code, Chapter 213 for identifying and implementing appropriate measures to reduce pollutants in Storm Water Discharges into identified sensitive areas of the Edwards Aquifer. The TCEQ TPDES Construction General Permit TXR150000, page 12, Item 5 "Discharge to the Edwards Aquifer Recharge Zone" identifies the requirement of protective measures of the Edwards Aquifer.

(Ord. No. 94002, § 1, 5-24-01)

Sec. 34-803. - Applicability of Subdivision B entitled "Storm Water Compliance for Construction Activity," and declaration of nuisance for violation.

Within the corporate limits of the city and within applicable limits of the city's extraterritorial jurisdiction (ETJ), no person shall perform construction activity that violates provisions of this subdivision. Construction activity in violation of this subdivision is hereby declared unlawful.

Violations committed within the corporate limits and within five thousand (5,000) feet outside the city's corporate limits shall also constitute public nuisance, as further provided below at Sec. 34-809, Violations of any provision of this subdivision within the City's corporate limits shall be deemed a criminal Class C misdemeanor. Violations of any provision of this subdivision within the city's corporate limits or any part of the applicable ETJ shall be further subject to a civil enforcement option, more particularly described in Sec. 34-808 (b) below.

Some of the requirements of this subdivision may be generally characterized as good house-keeping protocols, those expected to be employed by a reasonably prudent contractor, operator, owner, or other person having responsibilities for various activities on a construction site. Where state or federal permits require the site operator, owner, or other responsible party, to make a storm water pollution prevention plan (SWPPP), such plans must be readily available on the site for city inspection.

(Ord. No. 94002, § 1, 5-24-01)

Sec. 34-804. - General prohibition against construction pollution of the municipal separate storm sewer; measurable volumes for violation; required TCEQ TPDES Permit; SWPPP and WPAP (as applicable).

(a) It is unlawful for any person to engage in construction activity which activity results in a measurable volume of sediment, soils, soils material, or pollutants entering the city's municipal separate storm sewer system (MS4).

(b) "Measurable volume" of sediment, soil, soil material, or pollutant, for purposes of determining a violation, shall be such volume as is capable of being truly and correctly depicted in a photograph, motion picture, or video recording of the sediment, soil, soil material, or pollutant in question.

(c) Nothing in this section shall diminish or change the general prohibitions against MS4 pollution found in section 34-702, Subdivision A, Division 5, of this Chapter 34, Prohibited discharges into the municipal separate storm sewer system. SAWS shall continue to exercise all enforcement powers set out in this Chapter 34, and to gather such evidence as may include, but not be limited to, samples and analysis

PART II-CODE

Chapter 34 - WATER AND SEWERS

ARTICLE VI. - WATER QUALITY CONTROL AND POLLUTION PREVENTION

DIVISION 5. - PROHIBITED DISCHARGES INTO THE MUNICIPAL SEPARATE STORM SEWER SYSTEM

appropriate to enforcement of Chapter 34 provisions.

(d) The responsible party shall use best management practices (BMP) to prevent sediment, soils, soils materials, and pollutants from entering the city's MS4.

(e) It is unlawful for any person to engage in construction activity without employing BMP necessary to protect the city's MS4 from run-off or other media capable of transporting sediment, soil, soil material, and pollutants into the city's MS4.

(f) The Responsible Party shall post at the main entrance of the site all operator notices including without limitation, such as Notice of Construction, Construction Site Notice, Contact Information and WPAP Notice of Construction (as examples).

(g) Portions of the Edwards Aquifer Recharge Zone and Edwards Aquifer Contributing Zone within the City of San Antonio extraterritorial jurisdiction shall be considered inclusive in this Section.

(h) The operator shall have available and maintain on the construction site a copy of the SWPPP and where applicable, the WPAP.

(i) It is unlawful for any person to engage in construction activity without a complete SWPPP (as defined in TCEQ TXR 150000 or WPAP (as applicable) available on the construction site

(Ord. No. 94002, § 1, 5-24-01)

Sec. 34-805. - Additional federal and state requirements generally applicable to responsible parties associated with TPDES Regulated Projects: proper custody of federal or state storm water pollution prevention plans (SWPPP); applicable to parties required to provide TPDES notice of intent (NOI) or Small Construction Site Notice (CSN) to EPA or TCEQ and San Antonio Water System (SAWS); requirement to post TPDES Notices at site; requirement to make SWPPP available to city inspector; copy of Notice of Termination (NOT) or Small Construction Site or Large Construction Site Secondary Operator completed site notices required by TCEQ or SAWS.

(a) Concerning projects for which the EPA or TCEQ or the City have permitting authority, the responsible party shall post at the site, as required by federal or state regulations, a true and correct copy of the NOI, Permit Number, Large Construction Site Notice or Small Construction Site Notice. A copy of the NOI, Permit Number, Large Construction Site Notice or Small Construction Site Notice and the WPAP Notice of Construction shall also be sent to SAWS Resource Protection and Compliance Department at the same time it is sent to EPA or TCEQ when applicable.

(b) The responsible party shall have available for city inspection, on site, the storm water pollution prevention plan (SWPPP) imposed by EPA or TCEQ, when the site in question is subject to such plans imposed by federal or state law.

(c) The responsible party shall make the SWPPP available to the city inspector, on reasonable request made during normal working hours.

PART II- CODE

Chapter 34 - WATER AND SEWERS

ARTICLE VI. - WATER QUALITY CONTROL AND POLLUTION PREVENTION

DIVISION 5. - PROHIBITED DISCHARGES INTO THE MUNICIPAL SEPARATE STORM SEWER SYSTEM

- (d) Failure, refusal, or inability to provide such plan for inspection, when the plan is required under state or federal law, constitutes a violation of this subdivision.
- (e) It shall be unlawful for any person to engage in construction activity in violation of the elements of an applicable SWPPP and applicable WPAP.
- (t) The responsible party shall provide SAWS a true and correct copy of any notice of termination (NOT), Small Construction Site completed site notice or Large Construction Site Secondary Operator completed site notice necessary to close out a project regulated by EPA or TCEQ. This copy shall be sent to SAWS, to the attention of SAWS Resource Protection and Compliance Department, at the time it is sent to EPA or TCEQ.
- (g) Where permanent improvements have been constructed, the final inspection shall verify whether or not the "final stabilization" criteria have been met.
- (h) Where no permanent improvements are planned, temporary BMPs shall continue to be maintained until site has reached final stabilization.
- (i) A site shall continue to be regulated and maintain an open, active permit until final stabilization is achieved; and, where applicable to state and federally regulated sites, until a "notice of termination" (NOT) or Small Construction Site completed site notice or Large Construction Site Secondary Operator completed site notice has been filed. A copy of the NOT, if applicable, will also be filed with the SAWS as described above at subsection (t).
- (k) Where the site has met final stabilization requirements, but the controls or measures implemented thereafter fail, each discharge of construction related contamination by the responsible party shall constitute a violation of this subdivision B.
- (k) Removal of temporary BMPs shall be required after the site achieves final stabilization.
- (l) The responsible party shall have available for City inspection on the construction site, a true copy of an approved master plan of development.
- (m) The Responsible Party shall have available on the construction site the Water Pollution Abatement Plan (WPAP) and WPAP Approval Notice imposed by TCEQ when the site in question is subject to such plans required by TCEQ in 30 Texas Administrative Code, Chapter 213.
- (n) The Responsible Party shall have available for City inspection all records and documents required by the EPA or TCEQ SWPPP and TCEQ WPAP (as applicable).
- (o) All SWPPP documents shall be designed and signed by a Licensed Professional Engineer (Texas) with competence in this area as required by Texas Engineering Practice Act, Section 137, or a Certified Professional in Erosion and Sedimentation Control (CPESC), or other registered/certified professional with competence in this area (such as a landscape architect) or as required by the State of Texas TCEQ.

PART II-CODE

Chapter 34 - WATER AND SEWERS

ARTICLE VI. - WATER QUALITY CONTROL AND POLLUTION PREVENTION

DIVISION 5. - PROHIBITED DISCHARGES INTO THE MUNICIPAL SEPARATE STORM SEWER SYSTEM

(p) To assure continued effective compliance with best management practice methodology on the construction/development site, the owner and/or engineer or certified inspector such as CPESC, Certified Erosion, Sediment and Storm Water Inspector (CESSWI) or Certified Inspector of Sediment and Erosion Control (CISEC) or other equal certification as may be required by the State of Texas, (hereafter referred to as owner's representative) shall conduct ongoing inspections of all erosion/sedimentation controls and direct the person or firm responsible for maintenance to make any repairs or modifications necessary within 48 hours of the initial notification.

(Ord. No. 94002, § 1, 5-24-01)

Sec. 34-806. - Best management practices (BMP) guidelines; compliance with this subdivision should not be relied upon by the regulated community to automatically effect compliance with what may be more stringent federal or state regulations pertaining to EPA/TNRCC TCEQ permitted construction sites; explanation of federal jurisdiction.

(a) BMP applications recommended to responsible parties are those techniques described in TCEQ's "Technical Guidance on Best Management Practices," document no. RG-348, Revised July- 2005, as such document may be updated and revised, or when available, the city's Technical Guidance Manual for Construction Activity.

(b) Responsible parties are advised that the city's recognition of BMP and other good house-keeping protocols are not necessarily synonymous with federal standards directly associated with EPA's Construction General Permit for other construction sites regulated under federal law or the TCEQ's Construction General Permit. Some sites will be federally regulated construction sites while most construction sites will be permitted by the State of Texas under guidelines similar to those of EPA. Responsible parties whose projects of scale fall within state or federal parameters are responsible to EPA or TCEQ to fulfill requirements that may differ from or may be more stringent than the provisions of this ordinance applying to local, individual construction sites of a scale not regulated by state or federal authorities.

(c) In contrast, the purpose of this subdivision and its requirements for BMP are to satisfy the City's own State permit which specifically requires the City to adopt a construction site regulation. Consequently, the intent of this subdivision is to protect MS4 from pollutants generated from local construction sites. Federal and State jurisdiction to support this directive is found in the conduit of urban runoff traversing the San Antonio area into rivers, streams, and especially bays regulated as "waters of the United States of America" and "waters of the State of Texas". Hence, storm water generated in the area of San Antonio may enter into and impact state and federal waters.

(Ord. No. 94002, § 1, 5-24-01)

Sec. 34-807. - Enforcement procedures.

(a) The director of public works may designate additional field enforcement staff to supplement SAWS Resource Protection and Compliance Department staff, here designated and referred to above and hereafter as city inspectors (inspectors).

PART II- CODE

Chapter 34- WATER AND SEWERS

ARTICLE VI. - WATER QUALITY CONTROL AND POLLUTION PREVENTION

DIVISION 5. - PROHIBITED DISCHARGES INTO THE MUNICIPAL SEPARATE STORM SEWER SYSTEM

- (b) Upon observation of an alleged violation or condition an inspector believes constitutes a violation of this subdivision, the Inspector shall issue a Field Correction Notice (FCN) to a responsible party. The Field Correction Notice shall be personally delivered to a responsible party, if such person is available on site; or, in the absence of such person, shall be posted at the construction site and mailed by U.S. Mail or by electronic e-mail. Field Correction Notices shall afford two (2) 24-hour periods to correct the violation alleged. The first 24-hour period should be used to remediate and remove the offending material, if any, from the city's MS4, or obtain and post permit documents and/or provide a copy of a complete SWPPP and WPAP (as applicable). A second 24-hour grace period shall follow immediately to allow the responsible party to appropriately install or repair corrective BMP which was lacking or failed to protect city property.
- (c) If the violation is cured within forty-eight (48) hours, as described above, no further city action is required.
- (d) If correction is not made timely, the inspector may issue a stop work order.
- (e) If a stop work order is not honored at the site and/or corrective action is not timely accomplished to protect the city's MS4, citations may be issued or civil injunctive remedies with appropriate penalties may be pursued.
- (f) Additional or cumulative enforcement action may be taken as the seriousness of the alleged pollutant encroachment in the MS4 may warrant.
- (g) Additional compliance time may be afforded, if within the judgment and discretion of the inspector, municipal obligations to environmental health and safety and municipal stormwater compliance obligations to enforcement agencies are not compromised.
- (h) Upon observation of an alleged violation or condition an inspector believes constitutes a violation of a Water Pollution Abatement plan within the Edwards Aquifer Recharge Zone, the Inspector shall have the authority to issue a Field Correction Notice (FCN) to a responsible party. Delivery of the FCN shall be in accordance with the process as identified in paragraph (b) of this Section. The Field Correction Notice shall require immediate correction of the violation alleged or within 24 hours of observation of alleged violation as specified and documented by the Inspector on the FCN. If correction is not made timely, the Inspector may issue a Stop Work Order.

(Ord. No. 94002, § 1, 5-24-01)

Sec. 34-808. - Criminal and civil enforcement.

- (a) A penalty is hereby established whereby any person who shall violate any provision of this subdivision shall be deemed to be guilty of a misdemeanor and shall upon conviction be fined a minimum amount of not less than two hundred dollars (\$200.00) per violation and a maximum amount of not more than two thousand dollars (\$2,000.00) per violation. Each day of violation shall constitute a separate offense for purposes of the enforcement of this subdivision.
- (b) The city attorney has authority to pursue all legal, equitable, and criminal remedies appropriate to

PART II-CODE

Chapter 34 - WATER AND SEWERS

ARTICLE VI. - WATER QUALITY CONTROL AND POLLUTION PREVENTION

DIVISION 5. - PROHIBITED DISCHARGES INTO THE MUNICIPAL SEPARATE STORM SEWER SYSTEM

enforce all provisions of this subdivision, including, but not limited to, authority under the Texas Local Government Code, Chapter 54, providing for injunctive relief and court imposed civil penalties up to five thousand dollars (\$5,000.00) a day for violation of ordinances relating to discharge of a pollutant into a storm sewer system controlled by a municipality.

(c) Upon the written direction of the director of public works, advising of an alleged violation of any section of this subdivision, the city attorney, pursuant to subsection (d) above, is authorized to petition any court of competent jurisdiction for an injunction to enjoin the continuance of such violation and to secure any and all civil penalties within the jurisdiction of the appropriate court. This remedy shall be cumulative of and to all other enforcement remedies available to the city.

(d) The authority set out above shall in no way diminish the authority and responsibility of the city attorney to diligently prosecute violations of this subdivision through the municipal prosecutor's office.

(e) The SAWS is a co-permittee, under the federal permit, and a contractual enforcement arm of the City of San Antonio. In consultation with the city attorney, SAWS legal officers may exercise all or specific enforcement options enumerated in this subdivision B on behalf of the city.

(Ord. No. 94002, § 1, 5-24-01)

Sec. 34-809. - Declaration of nuisance within applicable limits of the city's ETJ; city's authority to enforce within five thousand (5,000) feet outside the city limits.

Under authority of the Texas Local Government Code, Sec. 217.042 (a) (b), noncompliance with provisions of this subdivision B, or violation of its provisions, is here declared a nuisance and by authority of the enabling statute such declaration of nuisance extends to and shall be applicable within both the corporate limits of the city and within five thousand (5,000) feet outside the limits. Accordingly, summary abatement authority rests in the city's enforcement officials when imminent threat to the public health, safety, or welfare may arise.

(Ord. No. 94002, § 1, 5-24-01)

Secs. 34-810-34-900. - Reserved.

APPENDIX P

CONCRETE BATCH PLANT RECORDS

If applicable, Operator must maintain Concrete Batch Plant records, as required by the general permit in this section.