

**ORGANIZED SEWAGE COLLECTION SYSTEM PLAN
FOR
LANDMARK NORTH-WEST**

October 19, 2023

MBC Job. No. 30371-0976

PREPARED BY:

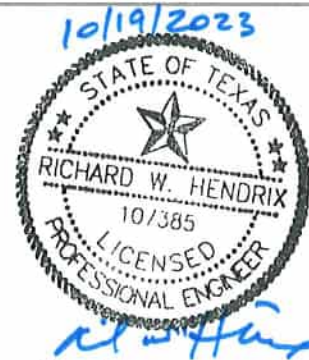
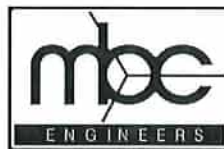

**MACINA · BOSE · COPELAND AND ASSOCIATES, INC.
dba MBC Engineers
Texas Registered Engineering Firm F-784 | SBE Certified #214046463
TBPLS Firm Registration No. 10011700
1035 Central Parkway North | San Antonio, Texas 78232
(210) 545-1122 Phone | (210) 545-9302 Fax
www.mbcengineers.com**

Texas Commission on Environmental Quality

Edwards Aquifer Application Cover Page

Our Review of Your Application

The Edwards Aquifer Program staff conducts an administrative and technical review of all applications. The turnaround time for administrative review can be up to 30 days as outlined in 30 TAC 213.4(e). Generally administrative completeness is determined during the intake meeting or within a few days of receipt. The turnaround time for technical review of an administratively complete Edwards Aquifer application is 90 days as outlined in 30 TAC 213.4(e). Please know that the review and approval time is directly impacted by the quality and completeness of the initial application that is received. In order to conduct a timely review, it is imperative that the information provided in an Edwards Aquifer application include final plans, be accurate, complete, and in compliance with [30 TAC 213](#).

Administrative Review

1. [Edwards Aquifer applications](#) must be deemed administratively complete before a technical review can begin. To be considered administratively complete, the application must contain completed forms and attachments, provide the requested information, and meet all the site plan requirements. The submitted application and plan sheets should be final plans. Please submit one full-size set of plan sheets with the original application, and half-size sets with the additional copies.

To ensure that all applicable documents are included in the application, the program has developed tools to guide you and web pages to provide all forms, checklists, and guidance. Please visit the below website for assistance: <http://www.tceq.texas.gov/field/eapp>.

2. This Edwards Aquifer Application Cover Page form (certified by the applicant or agent) must be included in the application and brought to the administrative review meeting.
3. Administrative reviews are scheduled with program staff who will conduct the review. Applicants or their authorized agent should call the appropriate regional office, according to the county in which the project is located, to schedule a review. The average meeting time is one hour.
4. In the meeting, the application is examined for administrative completeness. Deficiencies will be noted by staff and emailed or faxed to the applicant and authorized agent at the end of the meeting, or shortly after. Administrative deficiencies will cause the application to be deemed incomplete and returned.

An appointment should be made to resubmit the application. The application is re-examined to ensure all deficiencies are resolved. The application will only be deemed administratively complete when all administrative deficiencies are addressed.

5. If an application is received by mail, courier service, or otherwise submitted without a review meeting, the administrative review will be conducted within 30 days. The applicant and agent will be contacted with the results of the administrative review. If the application is found to be administratively incomplete, it can be retrieved from the regional office or returned by regular mail. If returned by mail, the regional office may require arrangements for return shipping.
6. If the geologic assessment was completed before October 1, 2004 and the site contains “possibly sensitive” features, the assessment must be updated in accordance with the *Instructions to Geologists* (TCEQ-0585 Instructions).

Technical Review

1. When an application is deemed administratively complete, the technical review period begins. The regional office will distribute copies of the application to the identified affected city, county, and groundwater conservation district whose jurisdiction includes the subject site. These entities and the public have 30 days to provide comments on the application to the regional office. All comments received are reviewed by TCEQ.
2. A site assessment is usually conducted as part of the technical review, to evaluate the geologic assessment and observe existing site conditions. The site must be accessible to our staff. The site boundaries should be

clearly marked, features identified in the geologic assessment should be flagged, roadways marked and the alignment of the Sewage Collection System and manholes should be staked at the time the application is submitted. If the site is not marked the application may be returned.

3. We evaluate the application for technical completeness and contact the applicant and agent via Notice of Deficiency (NOD) to request additional information and identify technical deficiencies. There are two deficiency response periods available to the applicant. There are 14 days to resolve deficiencies noted in the first NOD. If a second NOD is issued, there is an additional 14 days to resolve deficiencies. If the response to the second notice is not received, is incomplete or inadequate, or provides new information that is incomplete or inadequate, the application must be withdrawn or will be denied. Please note that because the technical review is underway, whether the application is withdrawn or denied **the application fee will be forfeited.**
4. The program has 90 calendar days to complete the technical review of the application. If the application is technically adequate, such that it complies with the Edwards Aquifer rules, and is protective of the Edwards Aquifer during and after construction, an approval letter will be issued. Construction or other regulated activity may not begin until an approval is issued.

Mid-Review Modifications

It is important to have final site plans prior to beginning the permitting process with TCEQ to avoid delays.

Occasionally, circumstances arise where you may have significant design and/or site plan changes after your Edwards Aquifer application has been deemed administratively complete by TCEQ. This is considered a “Mid-Review Modification”. Mid-Review Modifications may require redistribution of an application that includes the proposed modifications for public comment.

If you are proposing a Mid-Review Modification, two options are available:

- If the technical review has begun your application can be denied/withdrawn, your fees will be forfeited, and the plan will have to be resubmitted.
- TCEQ can continue the technical review of the application as it was submitted, and a modification application can be submitted at a later time.

If the application is denied/withdrawn, the resubmitted application will be subject to the administrative and technical review processes and will be treated as a new application. The application will be redistributed to the affected jurisdictions.

Please contact the regional office if you have questions. If your project is located in Williamson, Travis, or Hays County, contact TCEQ’s Austin Regional Office at 512-339-2929. If your project is in Comal, Bexar, Medina, Uvalde, or Kinney County, contact TCEQ’s San Antonio Regional Office at 210-490-3096

Please fill out all required fields below and submit with your application.

1. Regulated Entity Name: Landmark North-West				2. Regulated Entity No.: 106376296					
3. Customer Name: IH10/Loop 1604 Partners, Ltd.				4. Customer No.: 603349507					
5. Project Type: (Please circle/check one)	<input checked="" type="radio"/> New	Modification		Extension		Exception			
6. Plan Type: (Please circle/check one)	<input type="checkbox"/> WPAP	<input type="checkbox"/> CZP	<input checked="" type="checkbox"/> SCS	<input type="checkbox"/> UST	<input type="checkbox"/> AST	<input type="checkbox"/> EXP	<input type="checkbox"/> EXT	Technical Clarification	Optional Enhanced Measures
7. Land Use: (Please circle/check one)	<input type="checkbox"/> Residential		<input checked="" type="checkbox"/> Non-residential		8. Site (acres):		7.98		
9. Application Fee:	\$650.00		10. Permanent BMP(s):			Sedimentation/Filtration Pond (existing)			
11. SCS (Linear Ft.):	930		12. AST/UST (No. Tanks):			N/A			
13. County:	Bexar		14. Watershed:			Upper Leon Creek			

Application Distribution

Instructions: Use the table below to determine the number of applications required. One original and one copy of the application, plus additional copies (as needed) for each affected incorporated city, county, and groundwater conservation district are required. Linear projects or large projects, which cross into multiple jurisdictions, can require additional copies. Refer to the “Texas Groundwater Conservation Districts within the EAPP Boundaries” map found at:

http://www.tceq.texas.gov/assets/public/compliance/field_ops/eapp/EAPP%20GWCD%20map.pdf

For more detailed boundaries, please contact the conservation district directly.

Austin Region			
County:	Hays	Travis	Williamson
Original (1 req.)	—	—	—
Region (1 req.)	—	—	—
County(ies)	—	—	—
Groundwater Conservation District(s)	<input type="checkbox"/> Edwards Aquifer Authority <input type="checkbox"/> Barton Springs/ Edwards Aquifer <input type="checkbox"/> Hays Trinity <input type="checkbox"/> Plum Creek	<input type="checkbox"/> Barton Springs/ Edwards Aquifer	NA
City(ies) Jurisdiction	<input type="checkbox"/> Austin <input type="checkbox"/> Buda <input type="checkbox"/> Dripping Springs <input type="checkbox"/> Kyle <input type="checkbox"/> Mountain City <input type="checkbox"/> San Marcos <input type="checkbox"/> Wimberley <input type="checkbox"/> Woodcreek	<input type="checkbox"/> Austin <input type="checkbox"/> Bee Cave <input type="checkbox"/> Pflugerville <input type="checkbox"/> Rollingwood <input type="checkbox"/> Round Rock <input type="checkbox"/> Sunset Valley <input type="checkbox"/> West Lake Hills	<input type="checkbox"/> Austin <input type="checkbox"/> Cedar Park <input type="checkbox"/> Florence <input type="checkbox"/> Georgetown <input type="checkbox"/> Jerrell <input type="checkbox"/> Leander <input type="checkbox"/> Liberty Hill <input type="checkbox"/> Pflugerville <input type="checkbox"/> Round Rock

San Antonio Region					
County:	Bexar	Comal	Kinney	Medina	Uvalde
Original (1 req.)	<u>X</u>	—	—	—	—
Region (1 req.)	<u>X</u>	—	—	—	—
County(ies)	<u>X</u>	—	—	—	—
Groundwater Conservation District(s)	<input checked="" type="checkbox"/> Edwards Aquifer Authority <input type="checkbox"/> Trinity-Glen Rose	<input type="checkbox"/> Edwards Aquifer Authority	<input type="checkbox"/> Kinney	<input type="checkbox"/> EAA <input type="checkbox"/> Medina	<input type="checkbox"/> EAA <input type="checkbox"/> Uvalde
City(ies) Jurisdiction	<input type="checkbox"/> Castle Hills <input type="checkbox"/> Fair Oaks Ranch <input type="checkbox"/> Helotes <input type="checkbox"/> Hill Country Village <input type="checkbox"/> Hollywood Park <input checked="" type="checkbox"/> San Antonio (SAWS) <input type="checkbox"/> Shavano Park	<input type="checkbox"/> Bulverde <input type="checkbox"/> Fair Oaks Ranch <input type="checkbox"/> Garden Ridge <input type="checkbox"/> New Braunfels <input type="checkbox"/> Schertz	NA	<input type="checkbox"/> San Antonio ETJ (SAWS)	NA

I certify that to the best of my knowledge, that the application is complete and accurate. This application is hereby submitted to TCEQ for administrative review and technical review.

Richard W. Hendrix

Print Name of Customer/Authorized Agent	
Signature of Customer/Authorized Agent	Date

Richard W. Hendrix

10/19/2023

FOR TCEQ INTERNAL USE ONLY			
Date(s) Reviewed:		Date Administratively Complete:	
Received From:		Correct Number of Copies:	
Received By:		Distribution Date:	
EAPP File Number:		Complex:	
Admin. Review(s) (No.):		No. AR Rounds:	
Delinquent Fees (Y/N):		Review Time Spent:	
Lat./Long. Verified:		SOS Customer Verification:	
Agent Authorization Complete/Notarized (Y/N):		Fee Check:	Payable to TCEQ (Y/N):
Core Data Form Complete (Y/N):			Signed (Y/N):
Core Data Form Incomplete Nos.:			Less than 90 days old (Y/N):

– **General Information Form (TCEQ-0587)**

Attachment A - Road Map

Attachment B - USGS / Edwards Recharge Zone Map

Attachment C - Project Description

General Information Form

Texas Commission on Environmental Quality

For Regulated Activities on the Edwards Aquifer Recharge and Transition Zones and Relating to 30 TAC §213.4(b) & §213.5(b)(2)(A), (B) Effective June 1, 1999

To ensure that the application is administratively complete, confirm that all fields in the form are complete, verify that all requested information is provided, consistently reference the same site and contact person in all forms in the application, and ensure forms are signed by the appropriate party.

Note: Including all the information requested in the form and attachments contributes to more streamlined technical reviews.

Signature

To the best of my knowledge, the responses to this form accurately reflect all information requested concerning the proposed regulated activities and methods to protect the Edwards Aquifer. This **General Information Form** is hereby submitted for TCEQ review. The application was prepared by:

Print Name of Customer/Agent: Richard W. Hendrix, P.E.

Date: 10/19/2023

Signature of Customer/Agent:



Project Information

1. Regulated Entity Name: Landmark North-West
2. County: Bexar County
3. Stream Basin: Upper Leon Creek
4. Groundwater Conservation District (If applicable): _____
5. Edwards Aquifer Zone:
 - Recharge Zone
 - Transition Zone
6. Plan Type:
 - WPAP
 - SCS
 - Modification
 - AST
 - UST
 - Exception Request

7. Customer (Applicant):

Contact Person: Benjamin Dreszer

Entity: IH10/Loop 1604 Partners, LTD.

Mailing Address: 10003 N.W. Military Hwy, Suite 2205

City, State: San Antonio, Texas

Zip: 78231

Telephone: (210) 593-0777

FAX: (210) 593-0780

Email Address: benjamin@fulcrumsa.com

8. Agent/Representative (If any):

Contact Person: Richard W. Hendrix, P.E.

Entity: Macina, Bose, Copeland & Associates, Inc.

Mailing Address: 1035 Central Parkway N.

City, State: San Antonio, TX

Zip: 78232

Telephone: (210) 545-1122

FAX: (210) 545-9302

Email Address: rhendrix@mbcengineers.com

9. Project Location:

The project site is located inside the city limits of San Antonio.

The project site is located outside the city limits but inside the ETJ (extra-territorial jurisdiction) of _____.

The project site is not located within any city's limits or ETJ.

10. The location of the project site is described below. The description provides sufficient detail and clarity so that the TCEQ's Regional staff can easily locate the project and site boundaries for a field investigation.

The site is located on the southeast side of IH 10 and Loop 1604 interchange within the Upper Leon Creek watershed.

11. **Attachment A – Road Map.** A road map showing directions to and the location of the project site is attached. The project location and site boundaries are clearly shown on the map.

12. **Attachment B - USGS / Edwards Recharge Zone Map.** A copy of the official 7 ½ minute USGS Quadrangle Map (Scale: 1" = 2000') of the Edwards Recharge Zone is attached. The map(s) clearly show:

Project site boundaries.

USGS Quadrangle Name(s).

Boundaries of the Recharge Zone (and Transition Zone, if applicable).

Drainage path from the project site to the boundary of the Recharge Zone.

13. **The TCEQ must be able to inspect the project site or the application will be returned.** Sufficient survey staking is provided on the project to allow TCEQ regional staff to locate the boundaries and alignment of the regulated activities and the geologic or manmade features noted in the Geologic Assessment.

Survey staking will be completed by this date: TBD

14. **Attachment C – Project Description.** Attached at the end of this form is a detailed narrative description of the proposed project. The project description is consistent throughout the application and contains, at a minimum, the following details:

- Area of the site
- Offsite areas
- Impervious cover
- Permanent BMP(s)
- Proposed site use
- Site history
- Previous development
- Area(s) to be demolished

15. Existing project site conditions are noted below:

- Existing commercial site
- Existing industrial site
- Existing residential site
- Existing paved and/or unpaved roads
- Undeveloped (Cleared)
- Undeveloped (Undisturbed/Uncleared)
- Other: _____

Prohibited Activities

16. I am aware that the following activities are prohibited on the Recharge Zone and are not proposed for this project:

- (1) Waste disposal wells regulated under 30 TAC Chapter 331 of this title (relating to Underground Injection Control);
- (2) New feedlot/concentrated animal feeding operations, as defined in 30 TAC §213.3;
- (3) Land disposal of Class I wastes, as defined in 30 TAC §335.1;
- (4) The use of sewage holding tanks as parts of organized collection systems; and
- (5) New municipal solid waste landfill facilities required to meet and comply with Type I standards which are defined in §330.41(b), (c), and (d) of this title (relating to Types of Municipal Solid Waste Facilities).
- (6) New municipal and industrial wastewater discharges into or adjacent to water in the state that would create additional pollutant loading.

17. I am aware that the following activities are prohibited on the Transition Zone and are not proposed for this project:

- (1) Waste disposal wells regulated under 30 TAC Chapter 331 (relating to Underground Injection Control);

- (2) Land disposal of Class I wastes, as defined in 30 TAC §335.1; and
- (3) New municipal solid waste landfill facilities required to meet and comply with Type I standards which are defined in §330.41 (b), (c), and (d) of this title.

Administrative Information

18. The fee for the plan(s) is based on:

- For a Water Pollution Abatement Plan or Modification, the total acreage of the site where regulated activities will occur.
- For an Organized Sewage Collection System Plan or Modification, the total linear footage of all collection system lines.
- For a UST Facility Plan or Modification or an AST Facility Plan or Modification, the total number of tanks or piping systems.
- A request for an exception to any substantive portion of the regulations related to the protection of water quality.
- A request for an extension to a previously approved plan.

19. Application fees are due and payable at the time the application is filed. If the correct fee is not submitted, the TCEQ is not required to consider the application until the correct fee is submitted. Both the fee and the Edwards Aquifer Fee Form have been sent to the Commission's:

- TCEQ cashier
- Austin Regional Office (for projects in Hays, Travis, and Williamson Counties)
- San Antonio Regional Office (for projects in Bexar, Comal, Kinney, Medina, and Uvalde Counties)

20. Submit one (1) original and one (1) copy of the application, plus additional copies as needed for each affected incorporated city, groundwater conservation district, and county in which the project will be located. The TCEQ will distribute the additional copies to these jurisdictions. The copies must be submitted to the appropriate regional office.

21. No person shall commence any regulated activity until the Edwards Aquifer Protection Plan(s) for the activity has been filed with and approved by the Executive Director.

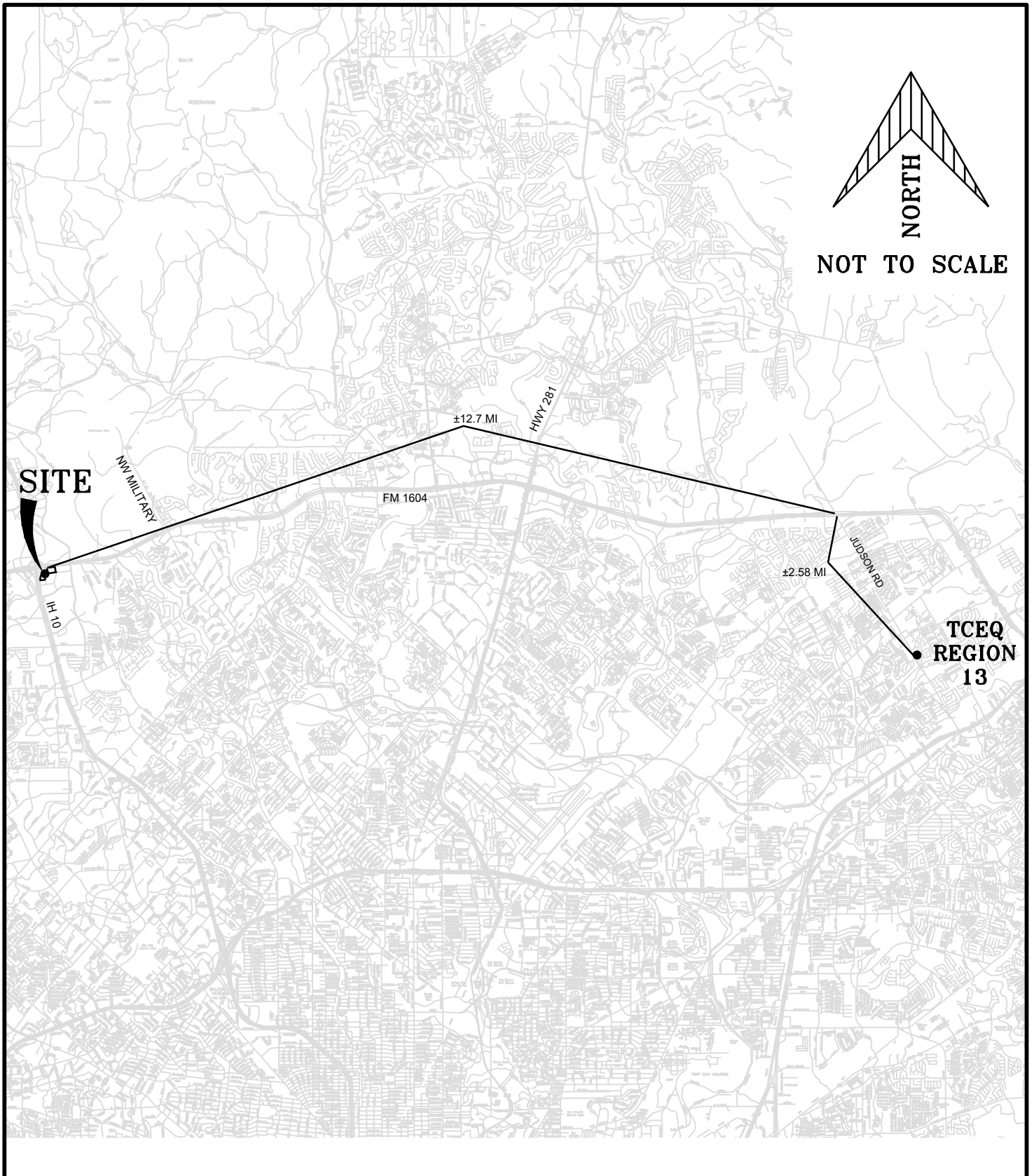

1035 Central Parkway North
 San Antonio, Texas 78232
 (210) 545-1122 FAX (210) 545-9302
 TEXAS REGISTERED ENGINEERING FIRM F-784

LANDMARK NORTH-WEST
SAN ANTONIO, TEXAS
ROAD MAP

DESIGN RH
 DRAWN RH
 CHECKED RH
 DATE AUGUST 2023
 JOB NO. 0976-30371
ATTACHMENT A

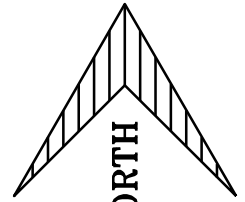
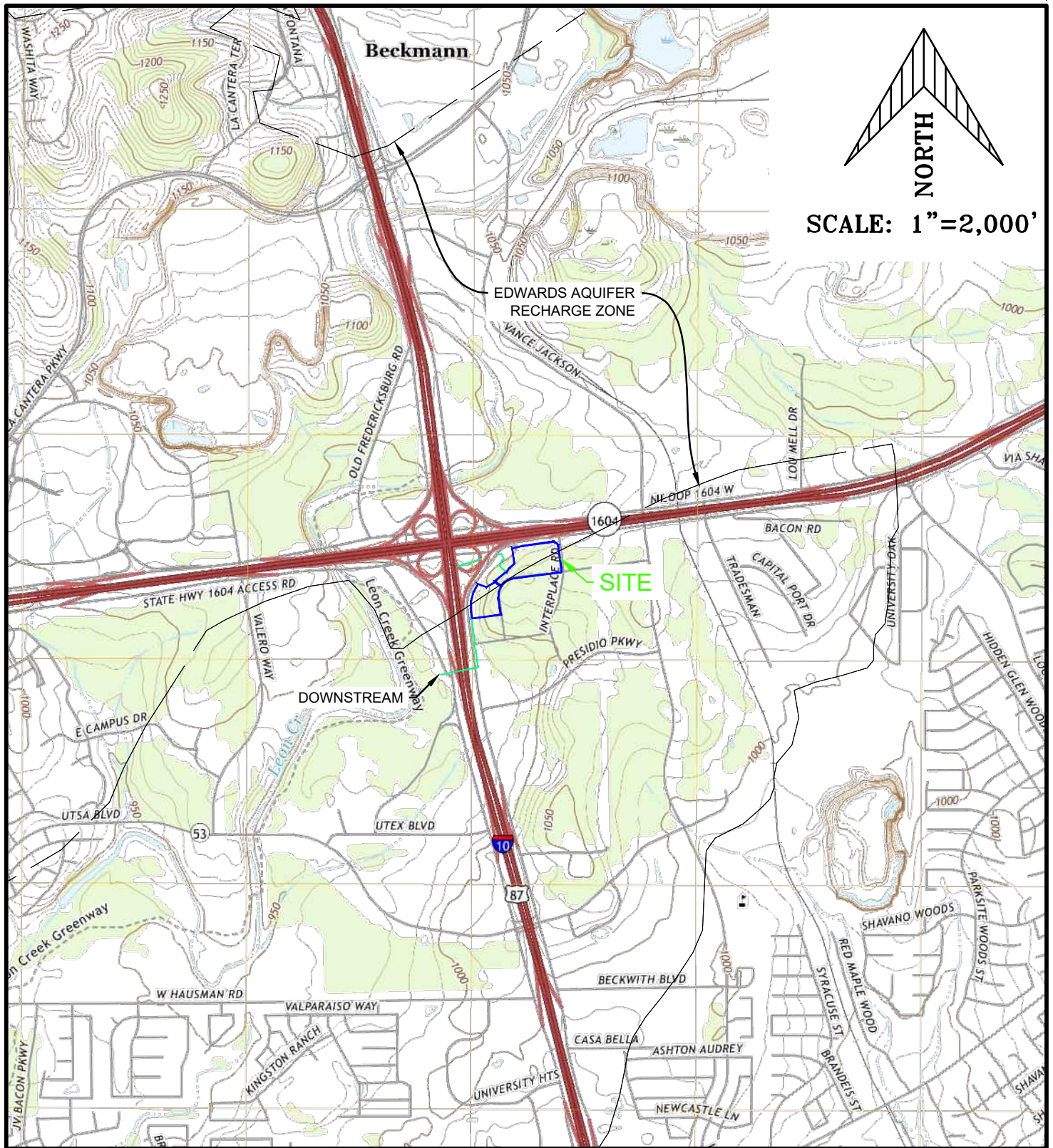

SCALE: 1"=2,000'

USGS QUAD: CASTLE HILLS

**LANDMARK NORTH-WEST
 ANTHEM PARKWAY
 SAN ANTONIO, TEXAS
 USGS EXHIBIT**

DESIGN	_____	RH
DRAWN	_____	RH
CHECKED	_____	DLA
DATE	_____	AUGUST 2023
JOB NO.	_____	30371/0976
EXHIBIT - C		



1035 Central Parkway North
 San Antonio, Texas 78232
 (210) 545-1122 FAX (210) 545-9302
 TEXAS REGISTERED ENGINEERING FIRM F-784

FORM 0587 ATTACHMENT

ATTACHMENT “C” - Project Description

Landmark North-West is a 12.139-acre tract of land to be developed. The development will include multiple office/retail buildings and associated parking. The entire 35.45 acres site is located in both the Recharge Zone and the Contributing Zone within the Transition Zone within the Upper Leon Creek Watershed. The site is located at the southeast corner of the IH-10 and Loop 1604 interchange.

Existing Conditions

The site currently has numerous live oak and cedar trees, along with typical underbrush associated with this type of terrain. The existing water quality pond was designed for ultimate development conditions that is located within the recharge zone. There are two existing asphalt roads, one located to the east and the other located directly south of the project site, several office buildings and apartments with associated parking.

Existing Drainage Conditions

The \pm 11.3952 acres north portion of the \pm 35.45 acres watershed located within or drains towards the recharge zone in the northwest/northeast direction with slopes ranging between 5.0% minimum to 8.1% maximum. The remaining \pm 19.1228 acres watershed located outside of the recharge zone, but within the contributing zone within the transition zone drains towards the southwest/southeast with slopes ranging a minimum of 4.0% to a maximum of 5.4% away from the recharge zone. Currently the existing developed area contributes \pm 14.26 acres of impervious cover to the overall \pm 35.45 project site.

Future Development

The existing water quality pond as mentioned before was designed for ultimate development conditions of the \pm 35.45 acres, as the remaining undeveloped portions of the site are planned for development at the client's discretion.

The Sewer Collection System construction will consist of 385 linear feet of private sanitary sewer main (size: 8”), 315 linear feet of private force main (size 6”) and 230 linear feet of private sanitary sewer lateral (size: 6”). The private sewer main will be connected to an existing public sewer system that is located south of the subject tract. The existing 8” main is located within an existing sewer easement on private property.

The overall tract that the sewer collection system will serve is approximately 12.139 acres and is located within the Edwards Aquifer Recharge Zone and Transition Zone. The “site area” which is considered a 100’ envelope around the proposed sewer alignment is approximately 2.5 acres.

This project is located within the city limits of San Antonio and San Antonio Water Systems (SAWS) will supply potable water to the project. Approximately 21,900 gallons per day of domestic wastewater is estimated to be generated by this development and will be discharged

into the proposed SCS. This daily flow value accounts for the peak flow and external contributions as required by the San Antonio Water System Utility Service Regulations 11.3.1. Wastewater is disposed of by conveyance to the existing Steven M. Clouse Water Recycling Center operated by SAWS.

– **Geologic Assessment Form (TCEQ-0585)**

Attachment A - Geologic Assessment Table (TCEQ-0585-Table)

Comments to the Geologic Assessment Table

Attachment B - Soil Profile and Narrative of Soil Units

Attachment C - Stratigraphic Column

Attachment D - Narrative of Site Specific Geology

Site Geologic Map(s)

Table or list for the position of features' latitude/longitude (if mapped using GPS)



GEOLOGIC ASSESSMENT (WPAP)

LANDMARK TRACT ***SOUTHWEST CORNER OF I.H. 10 AND LOOP 1604*** ***SAN ANTONIO, TEXAS***

FROST GEOSCIENCES, INC. PROJECT NO.: FGS-E15146
MAY 21, 2015

Prepared exclusively for

I.H. 10/Loop 1604 Partners, LTD
10003 N.W. Military Highway, Suite 2205
San Antonio, Texas 78231

Frost GeoSciences

Geotechnical ▪ Construction Materials
Geologic ▪ Environmental

Frost GeoSciences

Geotechnical • Construction Materials
Geologic • Environmental

Frost Geosciences, Inc.
13402 Western Oak
Helotes, Texas 78023
Office (210)-372-1315
Fax (210)-372-1318
www.frostgeosciences.com
TBPE Firm Registration # F-9227
TBPG Firm Registration # 50040

May 21, 2015

I.H. 10/Loop 1604 Partners, LTD
10003 N.W. Military Highway, Suite 2205
San Antonio, Texas 78231

Attn: Senior Geologist

SUBJECT:

Geologic Assessment (WPAP)
for the Regulated Activities / Development on the
Edwards Aquifer Recharge / Transition Zone
Landmark Tract
Southwest Corner of I.H. 10 and Loop 1604
San Antonio, Texas
FGS Project N^o FGS-EI5146

Dear Senior Geologist:

Frost GeoSciences, Inc., (FGS) is pleased to submit the enclosed Geologic Assessment completed for the above referenced Site as it relates to 30 TAC §213.5(b)(3), effective September 11, 2003. Our investigation was conducted, and this report was prepared in general accordance with the "Instructions to Geologists", TCEQ-0585-Instructions (Rev. 10-1-04).

If you have any questions regarding this report, or if Frost GeoSciences, Inc. may be of additional assistance to you on this project, please feel free to call our office. It has been a pleasure to work with you and we wish to thank you for the opportunity to be of service to you on this project. We look forward to being of continued service.

We appreciate the opportunity to perform these services for I.H. 10/Loop 1604 Partners, LTD. Please contact the undersigned if you have questions regarding this report.

Respectfully submitted,
Frost GeoSciences, Inc.

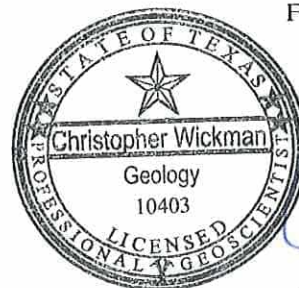

Chris Wickman, P.G.
Senior Geologist

Copies Submitted: (6) Senior Geologist; I.H. 10/Loop 1604 Partners, LTD
(1) Electronic (pdf) Copy

TABLE OF CONTENTS

GEOLOGIC ASSESSMENT.....1

STRATIGRAPHIC COLUMN..... 4

LOCATION..... 6

METHODOLOGY 6

RESEARCH & OBSERVATIONS..... 7

 7.5 Minute Quadrangle Map Review 7

 Recharge/Transition Zone..... 7

 100-Year Floodplain..... 7

 Soils..... 7

 Narrative Description of the Site Geology 8

BEST MANAGEMENT PRACTICES 10

DISCLAIMER 10

REFERENCES 11

APPENDIX A - Site Location Figures

 Figure 1: Site Layout

 Figure 2: Street Map

 Figure 3: USGS Topographic Map

 Figure 4: Bexar County Watersheds Map

 Figure 5: Official Edwards Aquifer Recharge Zone Map

 Figure 6: FEMA Flood Map

 Figure 7: USDA Soil Survey Aerial Photograph, 1 inch = 500 feet

 Figure 8A: U.S. Geological Survey, Water Resources Investigation # 4030-95

 Figure 8B: Geologic Map of the New Braunfels, TX 30 X 60 Minute Quadrangle

 Figure 9: 2014 Aerial Photograph, 1 inch = 500 feet

 Figure 10: 2014 Aerial Photograph with PRFs, 1 inch = 200 feet

APPENDIX B - Site Photographs

APPENDIX C - Site Geologic Map

Geologic Assessment

Texas Commission on Environmental Quality

For Regulated Activities on The Edwards Aquifer Recharge/transition Zones and Relating to 30 TAC §213.5(b)(3), Effective June 1, 1999

To ensure that the application is administratively complete, confirm that all fields in the form are complete, verify that all requested information is provided, consistently reference the same site and contact person in all forms in the application, and ensure forms are signed by the appropriate party.

Note: Including all the information requested in the form and attachments contributes to more streamlined technical reviews.

Signature

To the best of my knowledge, the responses to this form accurately reflect all information requested concerning the proposed regulated activities and methods to protect the Edwards Aquifer. My signature certifies that I am qualified as a geologist as defined by 30 TAC Chapter 213.

Print Name of Geologist: Chris Wickman

Telephone: (210) 372-1315

Date: May 21, 2015

Fax: (210) 372-1318

Representing: Frost Geosciences, Inc. License #50040 (Name of Company and TBPG or TBPE registration number)

Signature of Geologist:

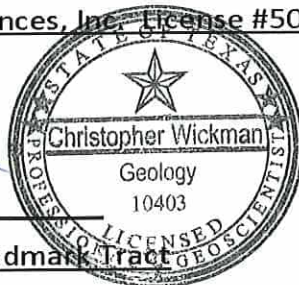

Regulated Entity Name: Landmark Tract

Project Information

1. Date(s) Geologic Assessment was performed: May 19, 2015

2. Type of Project:

WPAP
 SCS

AST
 UST

3. Location of Project:

Recharge Zone
 Transition Zone
 Contributing Zone within the Transition Zone

4. **Attachment A - Geologic Assessment Table.** Completed Geologic Assessment Table (Form TCEQ-0585-Table) is attached.
5. Soil cover on the project site is summarized in the table below and uses the SCS Hydrologic Soil Groups* (Urban Hydrology for Small Watersheds, Technical Release No. 55, Appendix A, Soil Conservation Service, 1986). If there is more than one soil type on the project site, show each soil type on the site Geologic Map or a separate soils map.

Table 1 - Soil Units, Infiltration Characteristics and Thickness

Soil Name	Group*	Thickness(feet)
Crawford & Bexar stony soils	D	0 - 1
Patrick soils	B	0 - 1.5
Tarrant soils	C	0 - 1

* Soil Group Definitions (Abbreviated)

- A. Soils having a high infiltration rate when thoroughly wetted.
- B. Soils having a moderate infiltration rate when thoroughly wetted.
- C. Soils having a slow infiltration rate when thoroughly wetted.
- D. Soils having a very slow infiltration rate when thoroughly wetted.

6. **Attachment B – Stratigraphic Column.** A stratigraphic column showing formations, members, and thicknesses is attached. The outcropping unit, if present, should be at the top of the stratigraphic column. Otherwise, the uppermost unit should be at the top of the stratigraphic column.
7. **Attachment C – Site Geology.** A narrative description of the site specific geology including any features identified in the Geologic Assessment Table, a discussion of the potential for fluid movement to the Edwards Aquifer, stratigraphy, structure(s), and karst characteristics is attached.
8. **Attachment D – Site Geologic Map(s).** The Site Geologic Map must be the same scale as the applicant's Site Plan. The minimum scale is 1": 400'
 Applicant's Site Plan Scale: 1" = 50'
 Site Geologic Map Scale: 1" = 50'
 Site Soils Map Scale (if more than 1 soil type): 1" = 500'
9. Method of collecting positional data:
 - Global Positioning System (GPS) technology.
 - Other method(s). Please describe method of data collection: 2014 Aerial Photograph
10. The project site and boundaries are clearly shown and labeled on the Site Geologic Map.
11. Surface geologic units are shown and labeled on the Site Geologic Map.

12. Geologic or manmade features were discovered on the project site during the field investigation. They are shown and labeled on the Site Geologic Map and are described in the attached Geologic Assessment Table.
- Geologic or manmade features were not discovered on the project site during the field investigation.
13. The Recharge Zone boundary is shown and labeled, if appropriate.
14. All known wells (test holes, water, oil, unplugged, capped and/or abandoned, etc.): If applicable, the information must agree with Item No. 20 of the WPAP Application Section.
- There are _____ (#) wells present on the project site and the locations are shown and labeled. (Check all of the following that apply.)
- The wells are not in use and have been properly abandoned.
- The wells are not in use and will be properly abandoned.
- The wells are in use and comply with 16 TAC Chapter 76.
- There are no wells or test holes of any kind known to exist on the project site.

Administrative Information

15. Submit one (1) original and one (1) copy of the application, plus additional copies as needed for each affected incorporated city, groundwater conservation district, and county in which the project will be located. The TCEQ will distribute the additional copies to these jurisdictions. The copies must be submitted to the appropriate regional office.

STRATIGRAPHIC COLUMN

[Hydrogeologic subdivisions modified from Maclay and Small (1976); groups, formations, and members modified from Rose (1972); lithology modified from Dunham (1962); and porosity type modified from Choquette and Pray (1970). CU, confining unit; AQ, aquifer]

Hydrogeologic subdivision	Group, formation, or member	Hydro-logic function	Thickness (feet)	Lithology	Field identification	Cavern development	Porosity/permeability type																	
Upper Cretaceous	Upper confining units	Eagle Ford Group	CU	30 – 50	Brown, flaggy shale and argillaceous limestone	Thin flagstones; petroliferous	None	Primary porosity lost/ low permeability																
		Buda Limestone	CU	40 – 50	Buff, light gray, dense mudstone	Porcelaneous limestone with calcite-filled veins	Minor surface karst	Low porosity/low permeability																
		Del Rio Clay	CU	40 – 50	Blue-green to yellow-brown clay	Fossiliferous; <i>Ilymatogyra arietina</i>	None	None/primary upper confining unit																
Lower Cretaceous	Edwards aquifer	Georgetown Formation	Karst AQ; not karst CU	2 – 20	Reddish-brown, gray to light tan marly limestone	Marker fossil; <i>Waconella wacoensis</i>	None	Low porosity/low permeability																
									Person Formation	Cyclic and marine members, undivided	AQ	80 – 90	Mudstone to packstone; <i>mitolid</i> grainstone; chert	Thin graded cycles; massive beds to relatively thin beds; crossbeds	Many subsurface; might be associated with earlier karst development	Laterally extensive; both fabric and not fabric/water-yielding								
		Leached and collapsed members, undivided	AQ	70 – 90	Crystalline limestone; mudstone to grainstone; chert; collapsed breccia	Bioturbated iron-stained beds separated by massive limestone beds; stromatolitic limestone	Extensive lateral development; large rooms	Majority not fabric/one of the most permeable																
																	Regional dense member	CU	20 – 24	Dense, argillaceous mudstone	Wispy iron-oxide stains	Very few; only vertical fracture enlargement	Not fabric/low permeability; vertical barrier	
		Kainer Formation	Grainstone member	AQ	50 – 60	<i>Mitolid</i> grainstone; mudstone to wackestone; chert	White crossbedded grainstone	Few																Not fabric/ recrystallization reduces permeability
																	Kirschberg evaporite member	AQ	50 – 60	Highly altered crystalline limestone; chalky mudstone; chert	Boxwork voids, with neospar and travertine frame	Probably extensive cave development	Majority fabric/one of the most permeable	
		Basal nodular member	Karst AQ; not karst CU	50 – 60	Shaly, nodular limestone; mudstone and <i>mitolid</i> grainstone	Massive, nodular and mottled, <i>Exogyra texana</i>	Large lateral caves at surface; a few caves near Cibolo Creek	Fabric; stratigraphically controlled/large conduit flow at surface; no permeability in subsurface																
									Lower confining unit	Upper member of the Glen Rose Limestone	CU; evaporite beds AQ	350 – 500	Yellowish tan, thinly bedded limestone and marl	Stair-step topography; alternating limestone and marl	Some surface cave development	Some water production at evaporite beds/relatively impermeable								

GEOLOGIC ASSESSMENT TABLE

PROJECT NAME: Landmark Tract

PROJECT NUMBER: FGS-E15146

LOCATION			FEATURE CHARACTERISTICS										EVALUATION			PHYSICAL SETTING				
1A	1B*	1C*	2A	2B	3	4			5	5A	6	7	8A	8B	9	10	11	12		
FEATURE ID	LATITUDE	LONGITUDE	FEATURE TYPE	POINTS	FORMATIO N	DIMENSIONS (FEET)			TREND (DEGREES)	DOM	DENSITY (NO/FT)	APERTURE (FEET)	INFILL	RELATIVE INFILTRATION RATE	TOTAL	SENSITIVITY	CATCHMENT AREA (ACRES)	TOPOGRAPHY		
						X	Y	Z								<40	>1.6	>1.6		
S-1	29° 35' 25.48"	-98° 35' 40.16"	F	20	Kep/Kbu	-	-	-	-	-	10	-	-	7	27	27	YES		HILLSIDE	

Datum: NAD 27

2A TYPE	TYPE	2B POINTS
C	Cave	30
SC	Solution cavity	20
SF	Solution-enlarged fracture(s)	20
F	Fault	20
O	Other natural bedrock features	5
MB	Manmade feature in bedrock	30
SW	Swallow hole	30
SH	Sinkhole	20
CD	Non-karst closed depression	5
Z	Zone, clustered or aligned features	30

8A INFILLING	DESCRIPTION
N	None, exposed bedrock
C	Coarse - cobbles, breakdown, sand, gravel
O	Loose or soft mud or soil, organics, leaves, sticks, dark colors
F	Fines, compacted clay-rich sediment, soil profile, gray or red colors
V	Vegetation. Give details in narrative description
FS	Flowstone, cements, cave deposits
X	Other materials

12 TOPOGRAPHY	DESCRIPTION
	Cliff, Hilltop, Hillside, Floodplain, Streambed

I have read, I understand, and I have followed the Texas Commission on Environmental Quality's Instructions to Geologists. The information presented here complies with that document and is a true representation of the conditions observed in the field. My signature certifies that I am qualified as a geologist as defined by 30 TAC 213.



Chris Wickman, P.G.

Date May 21, 2015

LOCATION

The Site is located in the southeastern corner of the intersection of Loop 1604 and Interstate Highway 10 (I.H. 10) in San Antonio, Texas. An overall view of the area is shown on copies of the site plan, a street map, the U.S.G.S. Topographic Map, the Bexar County Watersheds Map, the Official Edwards Aquifer Recharge Zone Map, the FIRM Map, the Bureau of Economic Geology Geologic Map of the New Braunfels, Texas 30 X 60 Minute Quadrangle, U.S. Geological Survey Water Resources Investigations 95-4030 Map, a 2014 aerial photograph at a scale of 1"=500', a 2014 aerial photograph at a scale of 1"=200', and a 1962 aerial photograph at a scale of 1"=500', Figures 1 through 10 in Appendix A.

METHODOLOGY

The Geologic Assessment was performed by Mr. Chris Wickman, P.G., Senior Geologist with Frost GeoSciences, Inc. Mr. Wickman is a Licensed Professional Geoscientist in the State of Texas (License # 10403).

Frost GeoSciences, Inc. researched the geology of the area east of the intersection of Loop 1604 and I.H. 10. The research included, but was not limited to, the Geologic Atlas of Texas, San Antonio Sheet, FEMA maps, Edwards Aquifer Recharge Zone Maps, U.S.G.S. 7.5 Minute Quadrangle Maps, the Bureau of Economic Geology-Geologic Atlas of Texas, the Geologic Map of the New Braunfels, Texas 30 X 60 Minute Quadrangle, the U.S.G.S. Water-Resources Investigations Report 95-4030, and the U.S.D.A. Soil Survey of Bexar County, Texas.

After reviewing the available information, a field investigation was performed to identify any geologic or man-made potential recharge features (PRFs). A transect spacing of approximately 50 feet, or less depending on vegetation thickness, was used to inspect the project area. A 2014 aerial photograph, in conjunction with a hand held Garmin GPS 72H Global Positioning System with an Estimated Potential Error ranging from 10 to 14 feet, was used to navigate around the property and identify the locations of PRFs, as recommended in the "Instructions to Geologists", TCEQ-0585-Instructions (Rev. 10-1-04). The locations of any PRFs noted in the field were marked with blue and white flagging. The flagging is numbered with the same PRF I.D. # that is used on the Site Geologic Map. The Site Geologic Map, indicating the limits of the Site, and the locations of PRFs and rock outcrops noted on the Site, is included in Appendix C. A copy of a 2014 Aerial Photograph at an approximate scale of 1"=200' indicating the limits of the Site, and the locations of potential recharge features and rock outcrops noted on the Site, is included on Figure 10 in Appendix A. The Geologic Assessment Form TCEQ-0585, (Rev. 10-1-10), Stratigraphic Column, and the Geologic Assessment Table have been filled with the appropriate information for this Site and are included on pages 1-5 of this report.

RESEARCH & OBSERVATIONS**7.5 Minute Quadrangle Map Review**

According to the U.S.G.S. 7.5 Minute Quadrangle Map, Castle Hills, Texas Sheet (1992), the elevation across the Site ranges from 990 to 1040 feet above mean sea level. The Site has a total relief of approximately 50 feet. The topographic map depicts the Site as undeveloped wooded land. Runoff from the Site flows to the north and northwest into Leon Creek. The intersection of Loop 1604 and I.H. 10 is located immediately northwest of the Site. A copy of the U.S.G.S. 7.5 Minute Quadrangle Map indicating the location of the Site is included on Figure 3 in Appendix A. According to the Bexar County Watersheds Map (2003), the Site is located within the Upper Leon Creek Watershed Area. A copy of the Bexar County Watersheds Map indicating the location of the Site is included on Figure 4 in Appendix A.

Recharge/Transition Zone

According to the Edwards Underground Water District Reference Map, (March 1988), the Official Edwards Aquifer Recharge Zone Map, Bulverde, Texas Sheet (1996) and the Edwards Aquifer Authority, Recharge Zone and Contributing Zone Map (1999), the Site is located within the Contributing and Recharge Zones of the Edwards Aquifer. A copy of the Edwards Aquifer Authority, Edwards Aquifer Recharge Zone and Contributing Zone Map, Castle Hills, Texas Quadrangle (1999) indicating the location of the Site is included on Figure 5 in Appendix A.

100-Year Floodplain

The Federal Emergency Management Agency (FEMA) Flood Insurance Rate Map for the Bexar County, Texas, Community Panel Number 48029C0230G (Revised September 29, 2010) was reviewed to determine if the Site is located in areas prone to flooding. A review of the above mentioned Panel Number indicated that the Site is located within "Zone X". According to the Panel Legend, Zone X represents areas determined to be outside the 0.2% annual chance floodplain. A copy of the above referenced FIRM panel indicating the location of the Site is included on Figure 6 in Appendix A.

Soils

According to the United States Department of Agriculture, Soil Conservation Service, Soil Survey of Bexar County, Texas, issued (1966), the Site is located on the Crawford and Bexar stony soils (Cb), Patrick Soils, 1 to 3 percent slopes (PaB) and the Tarrant Association (TaB). A copy of the 1962 aerial photo (approximate scale: 1"=500') from the U.S.D.A. Soil Survey of Bexar County, Texas indicating the location of the Site and the soil types is included on Figure 7 in Appendix A.

The Crawford and Bexar Stony Soils (Cb) are very dark grayish brown to reddish brown clay. They are stony clay in texture and are shallow to moderately deep over hard limestone. These soils are extensive in the northern part of the county. The surface layer is noncalcareous, about 8 inches thick, and very dark grayish brown or very dark brown. It has fine, subangular blocky and granular structure. When moist, this layer is very firm but breaks easily to a mass of fine clods. When dry, it is very hard and contains many large cracks. Angular fragments of chert and limestone are common.

These fragments may range in size from a quarter of an inch to 24 inches in diameter. The subsurface layer is dense, angular blocky clay. This layer is neutral or slightly acidic, but it may be limy in the lower parts. It is about 26 inches thick and either overlies a thin layer of yellowish red to pale brown, limy clay or, if the limy layer is lacking, rests on hard, fractured limestone. Crawford soils are naturally well drained. Internal drainage and permeability vary according to moisture content. Water moves rapidly when the soil is dry and cracked, but very slowly when the soil is wet. This soil has a USDA Texture Classification of Cherty Clay Loam to Loam. The Unified Classification is CG or CL. The AASHTO Classification is A-2, A-4, or A-6. This soil has an average permeability from 1.0 to 1.5 inches/hour.

Patrick soils, 1 to 3 percent slopes make up the most extensive acreage of Patrick soils mapped in the county. They are in the northern part and occur as nearly level to gently sloping terraces along streams that drain the limestone prairies. The terraces are 3 to 30 feet above the present streambeds. Areas of these soils are mostly long and narrow, or from 200 to 1,500 feet in width. The surface layer is clay loam, gravelly clay loam, silty clay or light clay and is about 12 inches thick. The subsurface layer, about 5 inches thick is brown clay loam, loam or light clay. This layer has granular structure. It is moderately permeable, firm to friable when moist and calcareous. Unless protected, the soils are susceptible to water erosion. This soil has a USDA Texture Classification of gravel bed containing loamy soil material. The Unified Classification is Gm or GC. The AASHTO Classification is A-2. This soil has an average permeability from 2.0 to 5.0+ inches/hour

The Tarrant Association consists of stony soils that are very shallow, dark colored, and gently undulating to steep. The Tarrant Association occurs on the limestone prairies in the northern third of the county. The surface layer is very dark grayish brown, calcareous clay loam and is about 10 inches thick. It has moderate, fine, subangular blocky structure. This layer is crumbly and friable when moist. Limestone fragments that range from a quarter of an inch to 24 inches in diameter cover about 35 percent of the surface. The subsurface layer, about 8 inches thick, is hard fractured limestone. The cracks and spaces are filled with dark grayish brown clay loam. The bedrock is hard limestone. Tarrant soils have rapid surface drainage and good internal drainage. The capacity to hold water is low. Natural fertility is high. Water erosion is a hazard. This soil has a USDA Texture Classification of Clay Loam. The Unified Classification is CL or CH. The AASHTO Classification is A-7. This soil has an average permeability from 1.0 to 1.5 inches/hour.

Narrative Description of the Site Geology

Based on a visual inspection of the ground surface, the overall potential for fluid flow from the Site into the Edwards Aquifer appears to be low. The locations of the PRFs are identified on the 2014 aerial photograph on Figure 10 in Appendix A, and on the Site Geologic Map provided in Appendix C. Color photos of the Site and some of the PRFs are included in Appendix B.

The Site is covered by moderately dense stand of vegetative cover with numerous open grassy areas. Selective clearing was observed in the northeastern portion of the Site with areas of spread mulch covering the ground surface. The spread mulch obscured the ground surface in these areas of the northeastern portion of the Site. Site visit photos indicating the condition of the property at the time of the on-site inspection are included in Appendix B. Overall vegetation on the Site consists of live oak (*Quercus virginiana*) cedar elm (*Ulmus crassifolia*), with Texas persimmon (*Diospyros texana*), agarita (*Berberis trifoliolata*), yucca (*Yucca treculeana*), and prickly pear cactus (*Opuntia lindheimeri*). The variations in the vegetative cover on the property are visible in the 2014 aerial photo on Figures 9 and 10 in Appendix A. A copy of the site layout indicating the boundary of the Site and the elevations is included on the Site Geologic Map in Appendix C of this report.

No obvious visual indications of PRFs were identified on the Site at the time of the site inspection. However, based on a review of the Site location depicted on the Geologic Map of the New Braunfels, Texas 30 X 60 Minute Quadrangle, the boundary of the contributing zone and the recharge zone is identified as and inferred fault. The inferred fault identified on the Geologic Map of the New Braunfels, Texas 30 X 60 Minute Quadrangle is labeled S-1 on the Site Geologic Map included with this report. This fault is the boundary between the Edwards aquifer recharge zone and the contributing zone. No obvious visual indications of this fault were observed on the Site at the time of the site inspection. According to the Geologic Map of the New Braunfels, Texas 30 X 60 Minute Quadrangle, the upwardly displaced formation to the north and northwest of the inferred fault is the Edwards Person Limestone and downwardly displaced formations to the southeast of the fault, are the Buda Limestone, Del Rio Clay and the Eagle Ford Formation. Frost GeoSciences, Inc. rates this feature as low on Figure 1 of the TCEQ-0585-Instructions (Rev. 10-01-04). The feature scores a 27 on the sensitivity scale, column 10 in the Geologic Assessment Table on Page 4 of this report. Frost GeoSciences, Inc. does consider this to be a sensitive feature.

According to the U.S. Geological Survey Water Resources Investigations, 95-4030 (WRI), and the Geologic Map of the New Braunfels, Texas 30 X 60 Minute Quadrangle, the Site is located on the Eagle Ford Group, Buda Limestone, Del Rio Clay and the Edwards limestone. According to the Geologic Map of the New Braunfels, Texas 30 x 60 Minute Quadrangle a very small area of Edwards limestone is located in the north and northeastern portions of the Site. The WRI map does not indicate Edwards limestone present on the Site. A copy of the WRI map and the Geologic Map of the New Braunfels, Texas 30 X 60 Minute Quadrangle are included on Figures 8A and 8B in Appendix A. A copy of the Stratigraphic Column highlighting the outcropping formations is included on Page 3 of this report.

The Eagle Ford Group consists of compact, silty shale containing fossil fish teeth and bones in the upper part. The middle part is a silty flaggy limestone grading to a medium gray calcareous siltstone. This part will weather to a pale yellowish brown. The lower part consists of dark gray calcareous shale. Overall thickness of the Eagle Ford Group ranges from 25 to 65 feet.

The Buda Limestone consists of buff to light gray dense mudstone to porcelaneous limestone with calcite filled veins. This formation develops minor surface karst. Overall thickness ranges from 40 to 50 feet.

The Del Rio Clay is the upper confining unit of the Edwards Aquifer and consists of blue-green to yellow-brown clay. This formation is fossiliferous with abundant *Ilymatogyra arietina*. This formation generally does not develop karst features. Overall thickness ranges from 40 to 50 feet.

The Edwards Limestone outcrops in the northwestern portion of the Site and is faulted out by a fault bearing N 70O. This has displaced Buda Limestone and the underlying Del Rio Clay along the south side of the fault. The Eagle Ford Formation is located in the northeastern and eastern portions of the Site as it sits on top of the Buda Limestone.

According to the site plan provided by MBC Engineers, the surveyed elevations on the Site range from 983 to 1035 feet. According to this survey, the total relief on the Site is approximately 52 feet. A copy of the site plan indicating the boundary of the Site and the elevations is included on the Site Plan on Figure 1 in Appendix A and the Site Geologic Map in Appendix C of this report.

BEST MANAGEMENT PRACTICES

Based on a visual inspection of the ground surface, the overall potential for fluid flow from the Site into the Edwards Aquifer appears to range from low to moderate. The potential always exists to encounter solution cavities within the subsurface during excavating activities. Frost GeoSciences, Inc. is of the opinion that it is very important for construction personnel to be informed of the potential to encounter cavities in the subsurface that lack a surface expression. Construction personnel should also be informed of the proper protocol to follow in the event a karst feature is encountered during the development of the Site.

DISCLAIMER

This report has been prepared in general accordance with the "Instructions to Geologists", TCEQ-0585-Instructions (Rev. 10-1-04) by a Licensed Texas Professional Geoscientist. All areas of the Site were carefully inspected for features that could contribute to the recharge of the Edwards Aquifer, however, this survey cannot preclude the presence of subsurface karst features that lack surface expression. This report is not intended to be a definitive investigation of all possible geologic or karst features at this site. All conclusions, opinions, and recommendations for Best Management Practices (BMP's) in this report are based on information obtained while researching the project, and on the site conditions at the time of our field investigation.

This report has been prepared for the exclusive use of I.H. 10/Loop 1604 Partners, LTD. This report is based on available known records, a visual inspection of the Site, and the work generally accepted for a Geologic Assessment for Regulated Activities / Developments on the Edwards Aquifer Recharge / Transition Zone, relating to 30 TAC §213.5(b)(3), effective June 1, 1999.

REFERENCES

1. USGS - 7.5 Minute Topographic Quadrangle of Castle Hills, Texas, 1992
2. Edwards Underground Water District Reference Map, March 1988
3. Official Edwards Aquifer Recharge Zone Map, Castle Hills, Texas, 1992
4. Stein, W.G. and Ozuna, G.B., 1995, Geologic Framework and Hydrogeologic Characteristics of the Edwards Aquifer Recharge Zone, Bexar County, Texas, U.S. Geological Survey Water Resources Investigations 95-4030.
5. Barnes, V.L., 1983, Geologic Atlas of Texas Sheet, Bureau of Economic Geology and University of Texas at Austin, Geologic Atlas of Texas.
6. Federal Emergency Management Agency, Federal Insurance Administration, National Flood Insurance Program, Flood Insurance Map, Community Panel Number 48029C0230G, dated September 29, 2010.
7. United States Department of Agriculture Soil Conservation Service Soil Survey of Bexar County 1962.
8. TCEQ-0585-Instructions (Rev. 10-1-04), "Instructions to Geologists for Geologic Assessments on the Edwards Aquifer Recharge/Transition Zone".
9. Collins, Edward, W., 2000, Geologic Map of the New Braunfels 30 X 60 Minute Quadrangle, Bureau of Economic Geology, The University of Texas at Austin, Texas.
10. San Antonio Water Systems, Bexar County Watersheds Map, 2004.

APPENDIX A
SITE LOCATION FIGURES

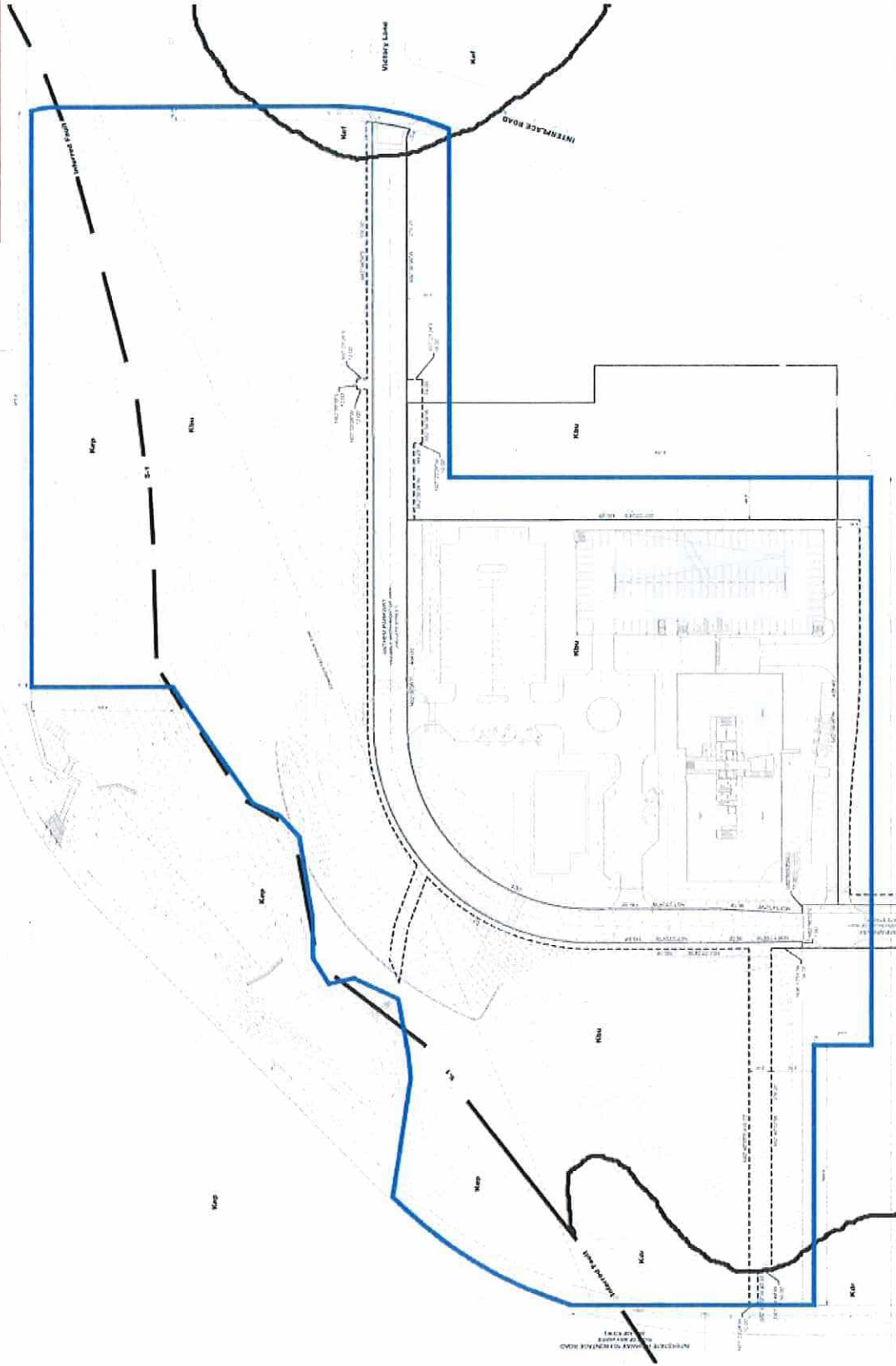

PROJECT NAME:
 Geologic Site Assessment (SCS)
 for Regulated Activities / Development on the
 Edwards Aquifer Recharge / Transition Zone
 Landmark Tract
 San Antonio, Texas

Site Layout

PROJECT NO.: FGS-EI5146

DATE: May 21, 2015

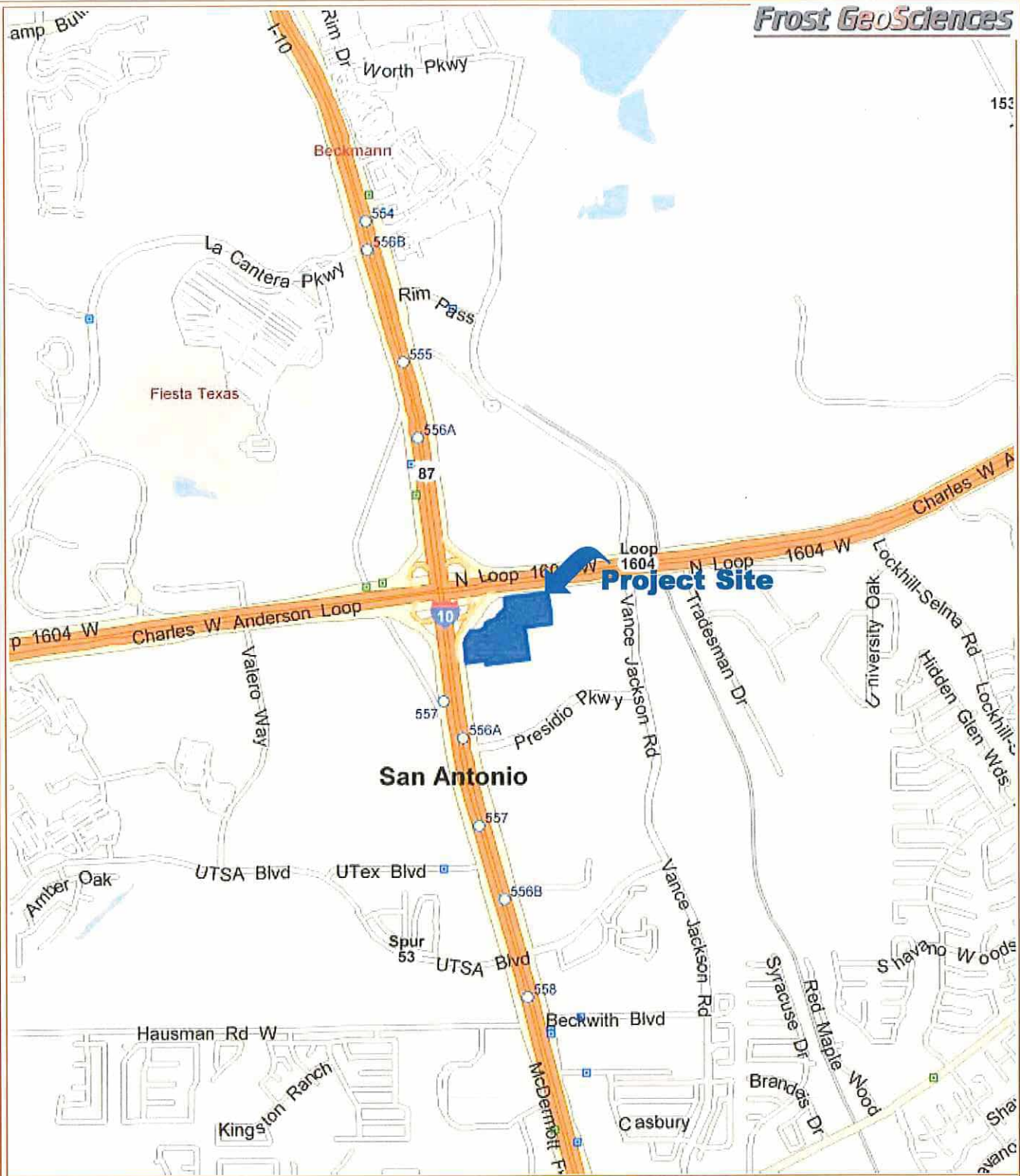

PROJECT NAME:

Geologic Site Assessment (WPAP)
 for Regulated Activities / Development on the
 Edwards Aquifer Recharge / Transition Zone
 Landmark Tract
 San Antonio, Texas

Street Map

PROJECT NO.:

FGS-E15146

DATE:

May 21, 2015

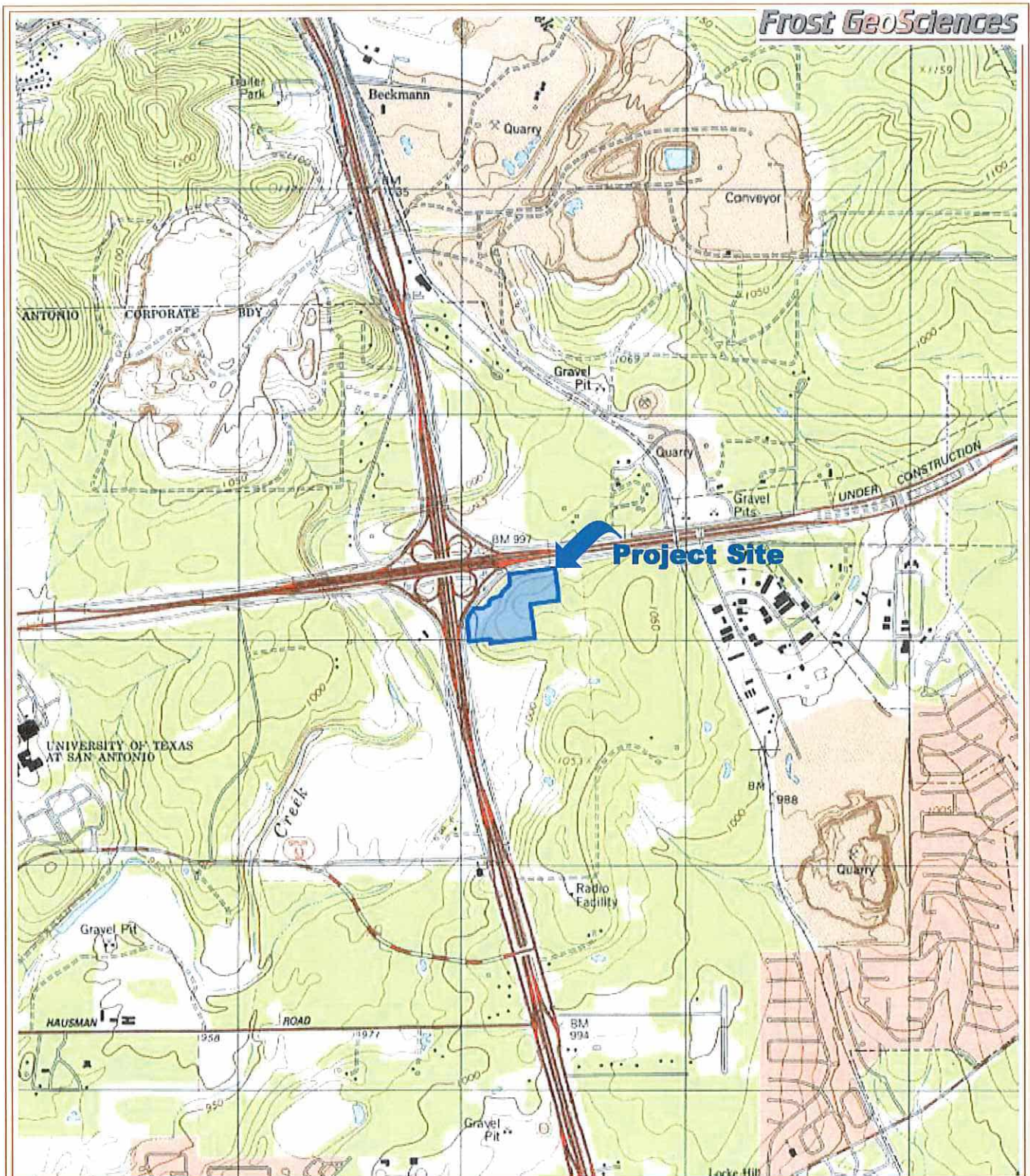

PROJECT NAME:

Geologic Site Assessment (WPAP)
for Regulated Activities / Development on the
Edwards Aquifer Recharge / Transition Zone
Landmark Tract
San Antonio, Texas

U.S.G.S. 7.5 Minute Quadrangle Map
Castle Hills, Texas Sheet (1992)

PROJECT NO.:

FGS-E15146

DATE:

May 21, 2015

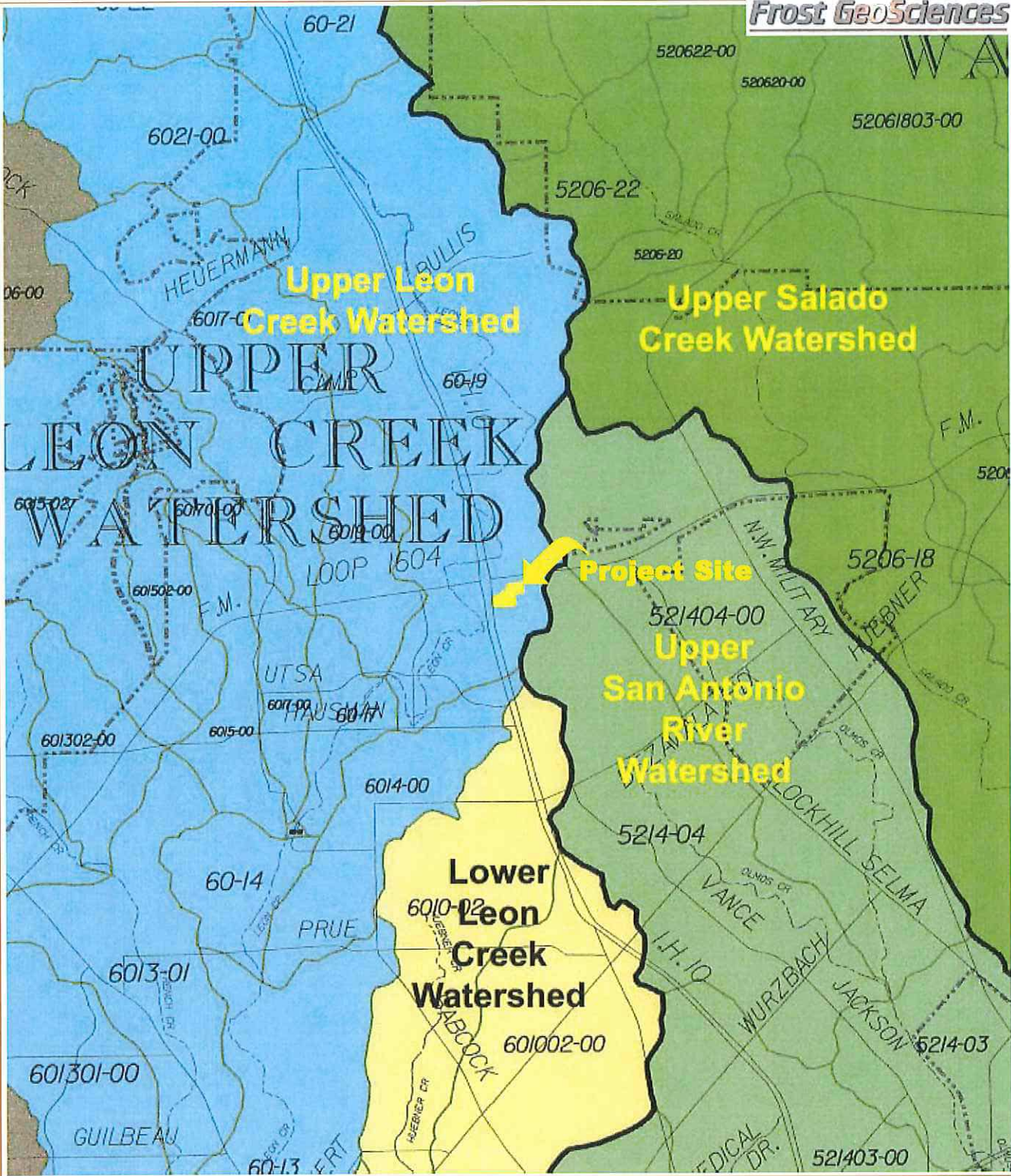

PROJECT NAME:

Geologic Site Assessment (WPAP)
for Regulated Activities / Development on the
Edwards Aquifer Recharge / Transition Zone
Landmark Tract
San Antonio, Texas

Bexar County Watersheds Map
San Antonio Water Systems (2004)

PROJECT NO.:

FGS-E15146

DATE:

May 21, 2015

Re

Recharge Zone

Project Site

Contributing Zone

PROJECT NAME:

Geologic Site Assessment (WPAP)
for Regulated Activities / Development on the
Edwards Aquifer Recharge / Transition Zone
Landmark Tract
San Antonio, Texas

AA-Edwards Aquifer Recharge and Contributing
Zone Map, Castle Hills, Texas Quadrangle (1999)

PROJECT NO.:

FGS-E15146

DATE:

May 21, 2015

City of San Antonio
Extraterritorial Jurisdiction
480035

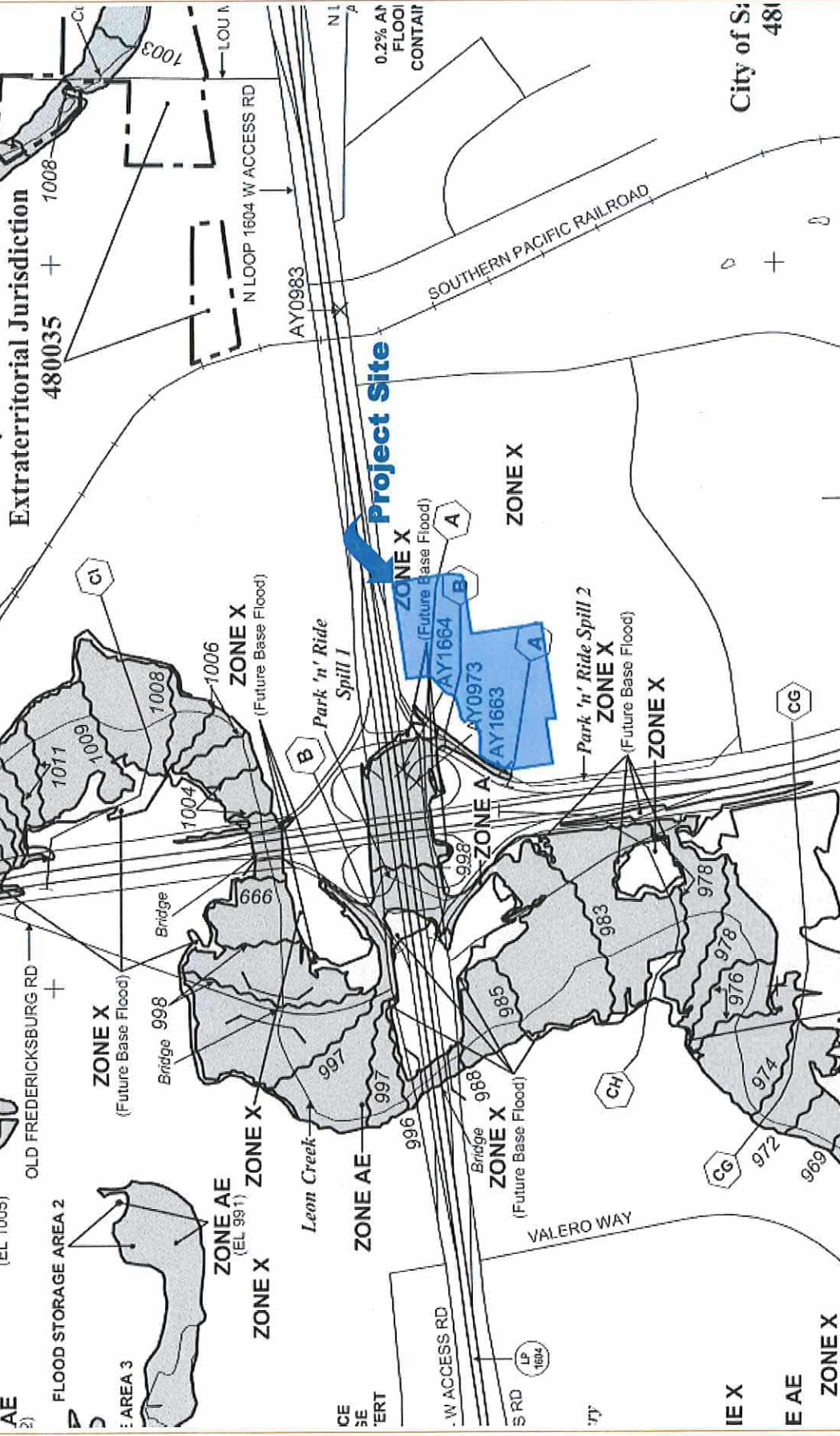

City of San Antonio
481

PROJECT NAME:
Geologic Site Assessment (WPAP)
for Regulated Activities / Development on the
Edwards Aquifer Recharge / Transition Zone
Landmark Tract
San Antonio, Texas

Flood Insurance Rate Map (FIRM)
Community Panel # 48029C0230G (9/29/2010)

PROJECT NO.: FGS-EI5146

DATE: May 21, 2015

FIGURE 6

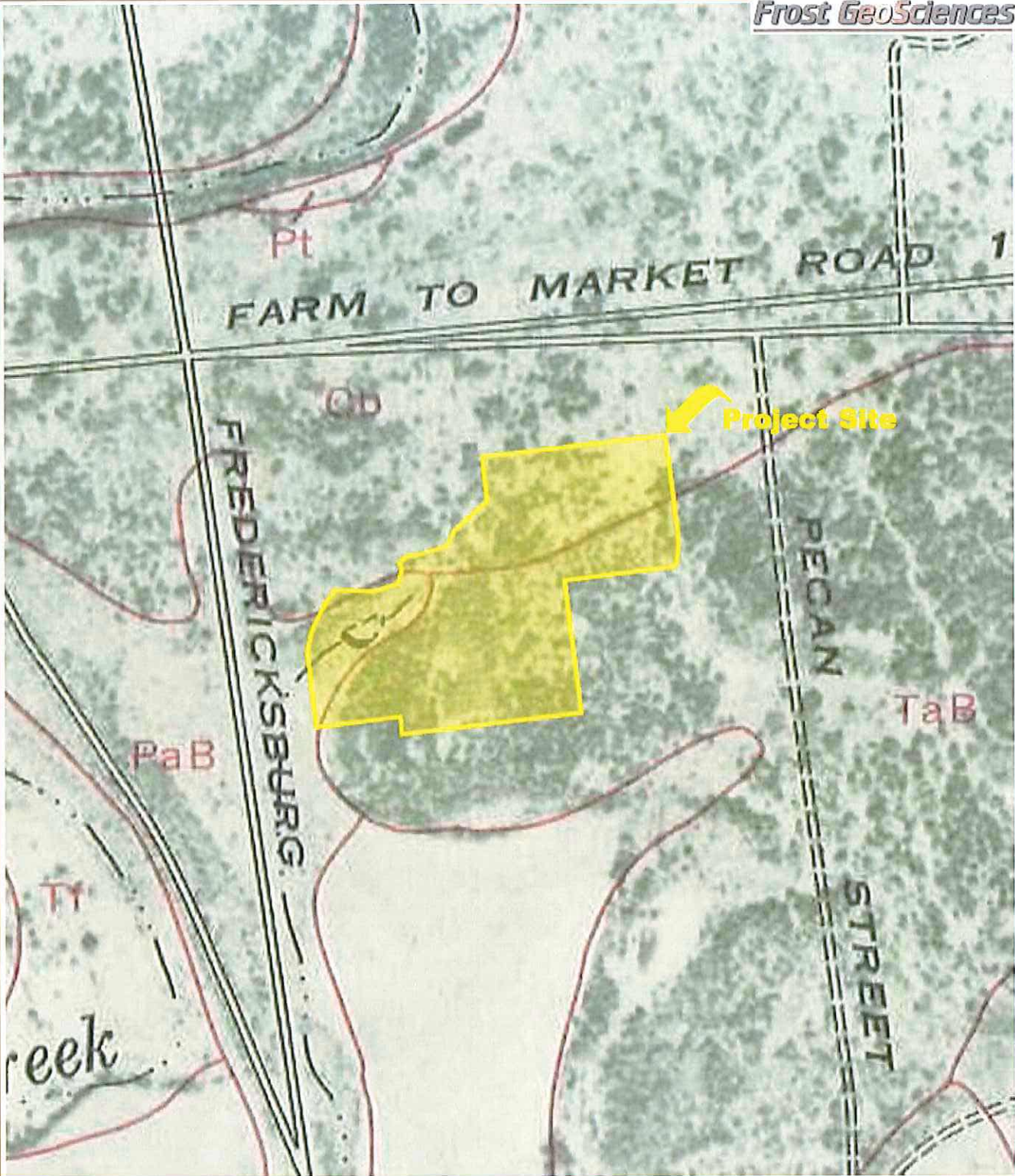

PROJECT NAME:

Geologic Site Assessment (WPAP)
for Regulated Activities / Development on the
Edwards Aquifer Recharge / Transition Zone
Landmark Tract
San Antonio, Texas

1962 Aerial Photograph
U.S.D.A. Soil Survey of Bexar County, Texas

PROJECT NO.:

FGS-E15146

DATE:

May 21, 2014

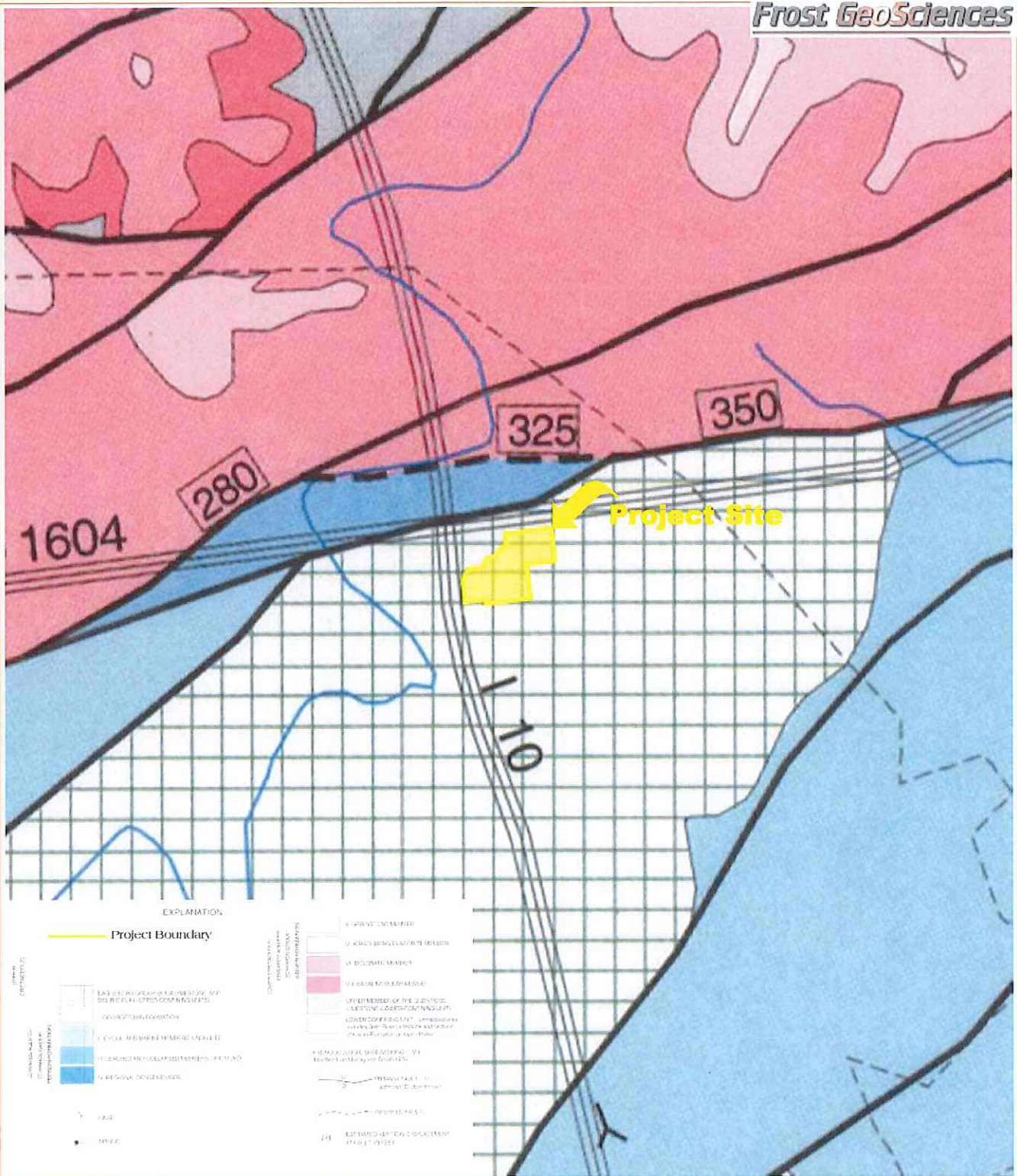

PROJECT NAME:
 Geologic Site Assessment (WPAP)
 for Regulated Activities / Development on the
 Edwards Aquifer Recharge / Transition Zone
 Landmark Tract
 San Antonio, Texas

United States Geologic Survey
 Water Resources Investigations #4030-95
 Geologic Map of Bexar County, Texas

PROJECT NO.:
 FGS-EI5146

DATE:
 May 21, 2015

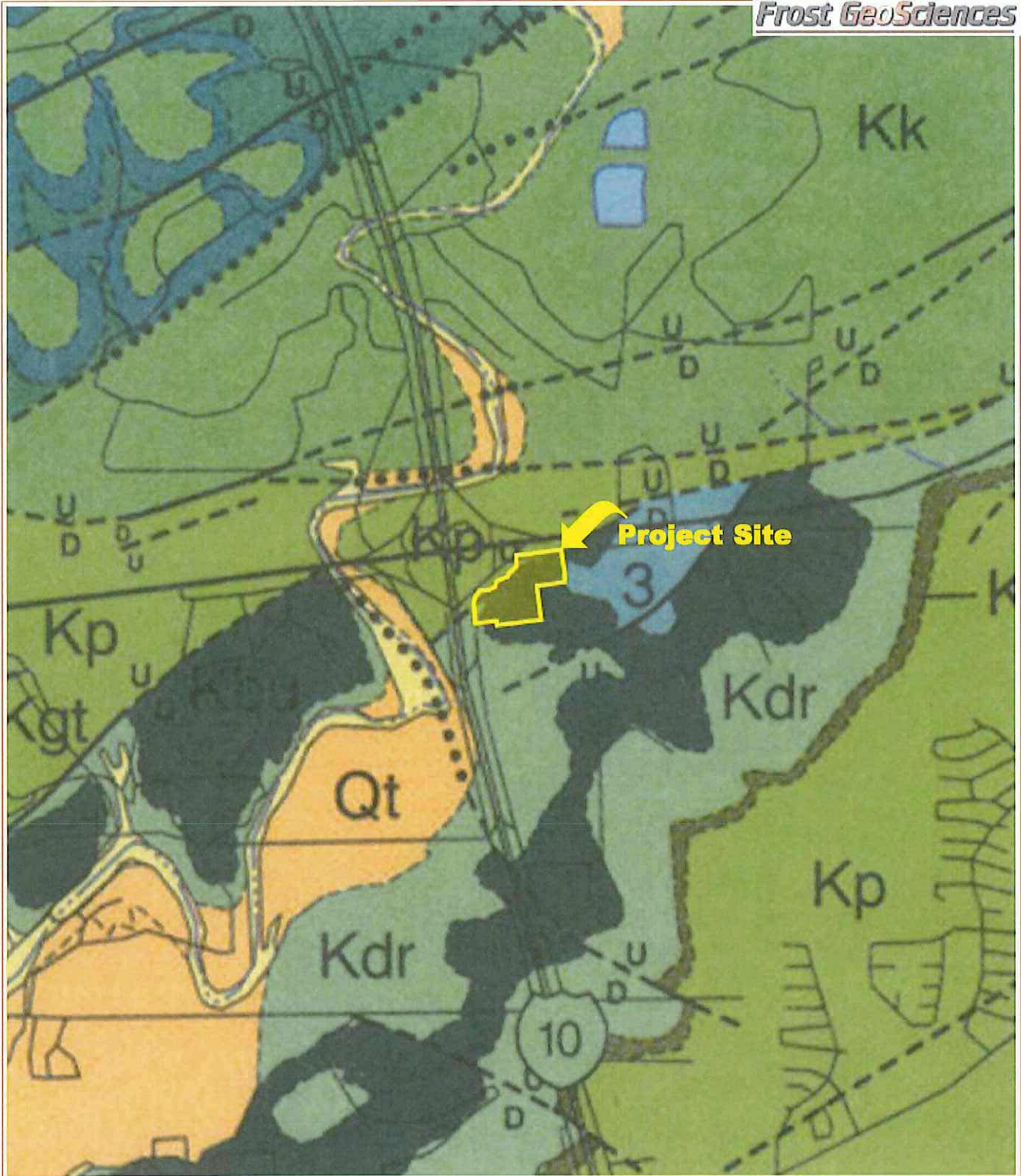

PROJECT NAME:
Geologic Site Assessment (WPAP)
for Regulated Activities / Development on the
Edwards Aquifer Recharge / Transition Zone
Landmark Tract
San Antonio, Texas

Bureau of Economic Geology
Geologic Map of the New Braunfels, Texas
30 X 60 Minute Quadrangle (2000)

PROJECT NO.:
FGS-E15146

DATE:
May 21, 2015



PROJECT NAME:

Geologic Site Assessment (WPAP)
for Regulated Activities / Development on the
Edwards Aquifer Recharge / Transition Zone
Landmark Tract
San Antonio, Texas

2014 Aerial Photograph
National Agricultural Imagery Program

PROJECT NO.:

FGS-E15146

DATE:

May 21, 2015

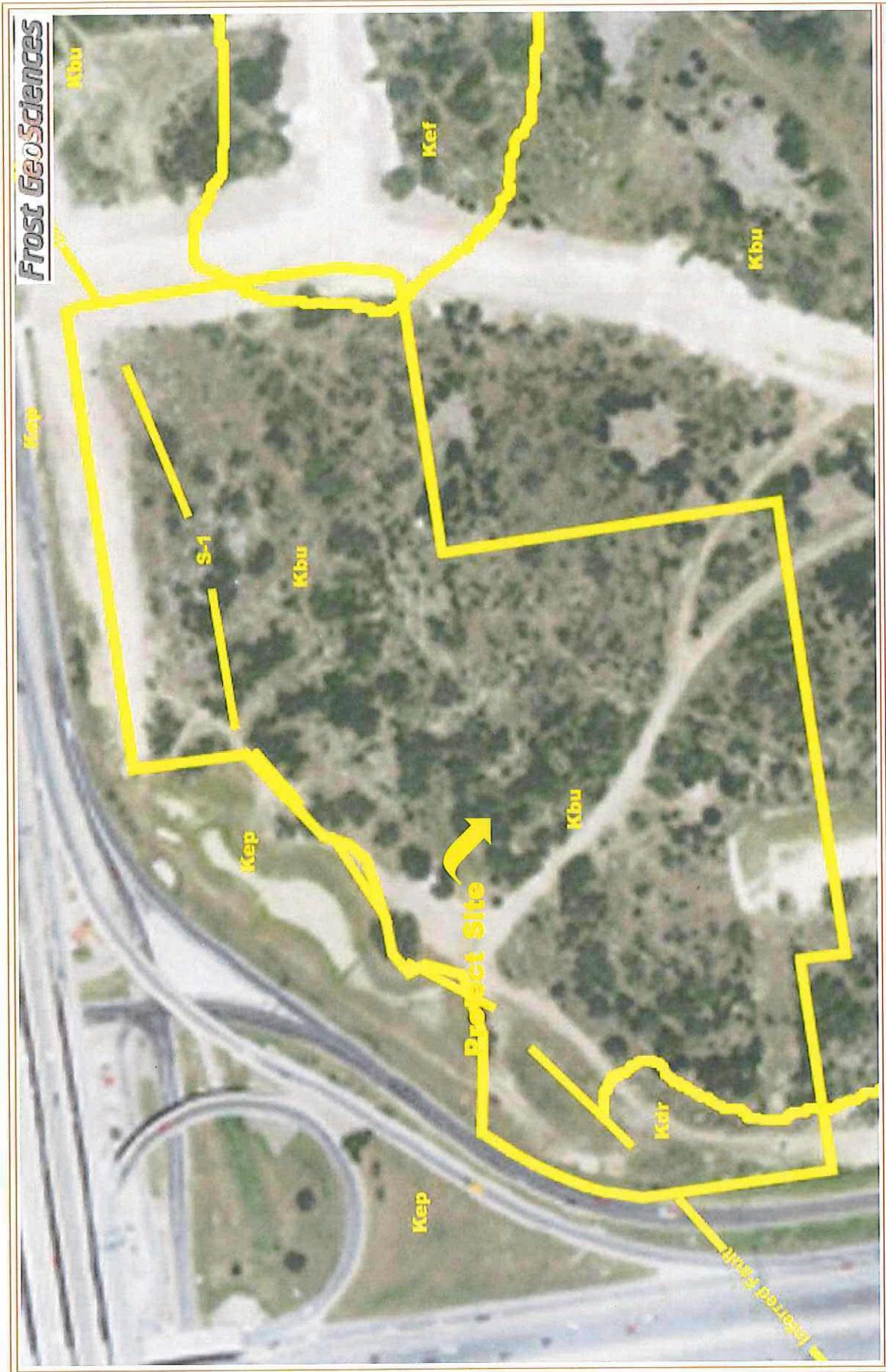

PROJECT NAME:
 Geologic Site Assessment (SCS)
 for Regulated Activities / Development on the
 Edwards Aquifer Recharge / Transition Zone
 Landmark Tract
 San Antonio, Texas

PROJECT NO.: FGS-E15146
DATE: May 21, 2015

APPENDIX B
SITE PHOTOGRAPHS

FGS Project N° FGS-EI5146



Photo #1 – Typical view of the vegetative cover observed in the southwestern portion of the Site.



Photo #2 – Typical view of the vegetative cover observed in the southwestern portion of the Site.



Photo #3 – Typical view of the vegetative cover observed in the central portion of the Site.



Photo #4 – Typical view of the vegetative cover observed in the central portion of the Site.



Photo #5 – Typical view of the vegetative cover observed in the southeastern portion of the Site.



Photo #6 – Typical view of the vegetative cover observed in the southeastern portion of the Site.



Photo #7 – Typical view of the vegetative cover observed in the northeastern portion of the Site.



Photo #8 – Typical view of the vegetative cover observed in the northeastern portion of the Site.



Photo #9 – Typical view of the vegetative cover observed in the eastern portion of the Site.



Photo #10 – Typical view of the vegetative cover observed in the eastern portion of the Site.

APPENDIX C

SITE GEOLOGIC MAP

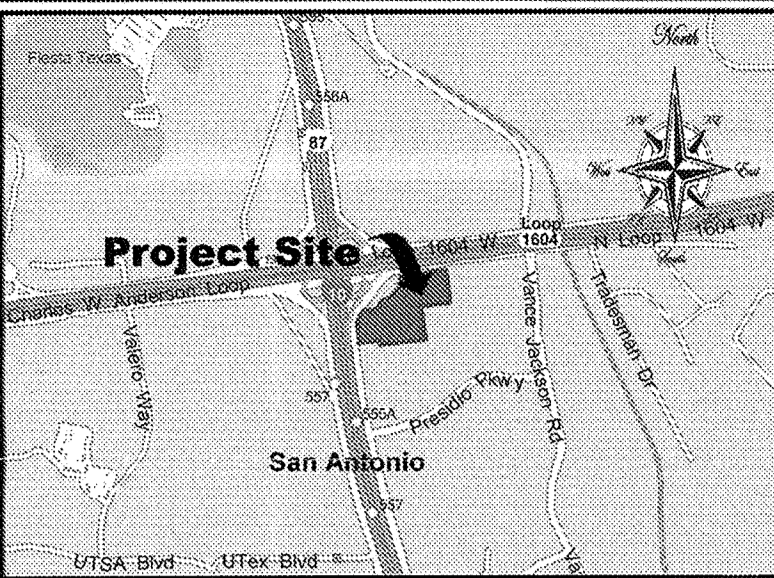

Location Map

Legend

- Fill - Fill Material
- Qal - Alluvium
- Kau - Austin Chalk
- Kef - Eagle Ford Shale
- Kbu - Buda Limestone
- Kdr - Del Rio Clay
- Kgt - Georgetown Limestone
- Kep - Edwards Person Limestone
- Kek - Edwards Kainer Limestone
- Kgr - Glen Rose Formation
- S-# - Potential Recharge Feature (PRF)
- - - - - Formation Contact
- - - - - Inferred Fault

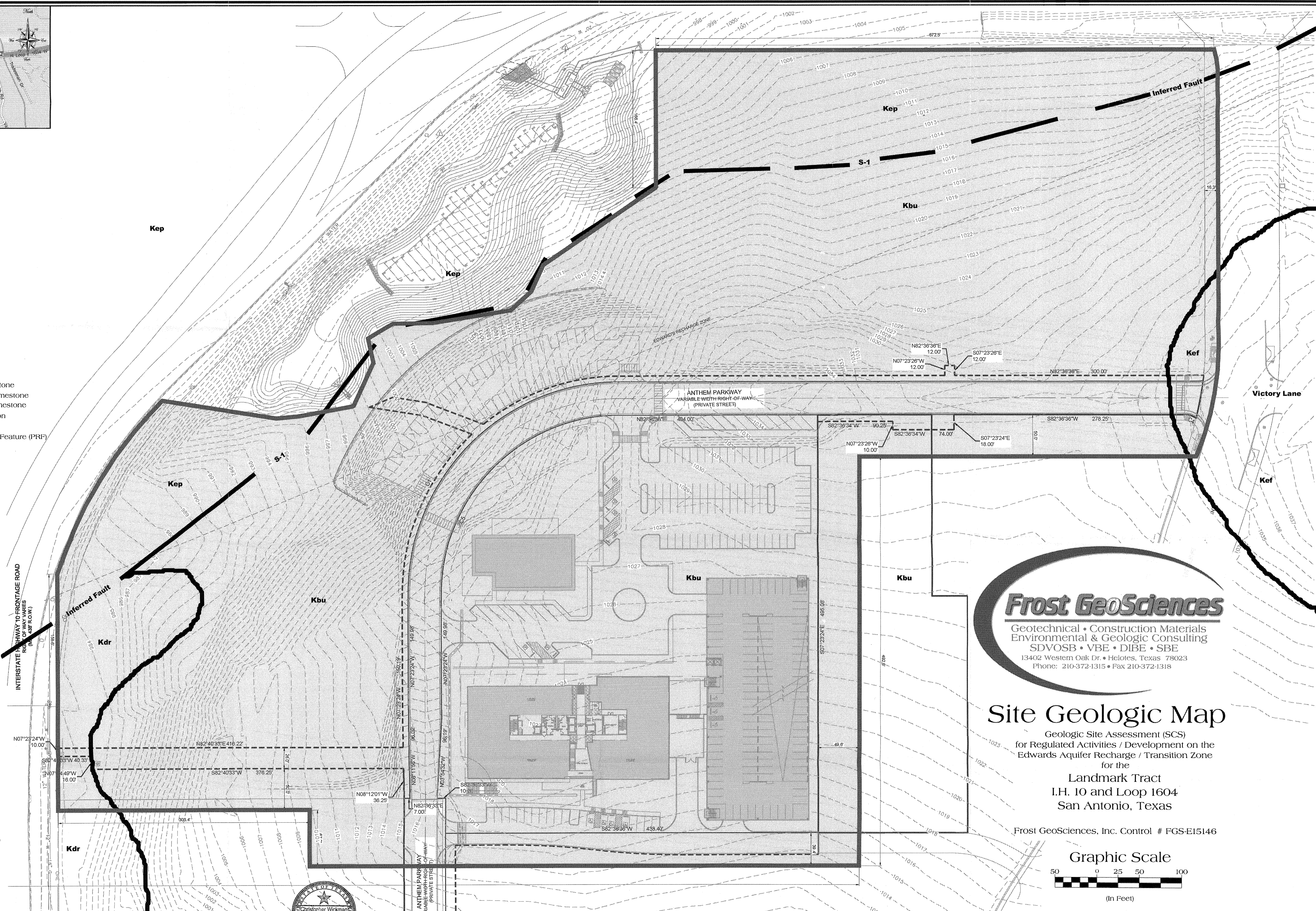

Frost GeoSciences
 Geotechnical • Construction Materials
 Environmental & Geologic Consulting
 SDVOSB • VBE • DIBE • SBE
 13402 Western Oak Dr. • Helotes, Texas 78023
 Phone: 210-372-1315 • Fax 210-372-1318

Site Geologic Map

Geologic Site Assessment (SCS)
 for Regulated Activities / Development on the
 Edwards Aquifer Recharge / Transition Zone
 for the
 Landmark Tract
 I.H. 10 and Loop 1604
 San Antonio, Texas

Frost GeoSciences, Inc. Control # FGS-EI5146

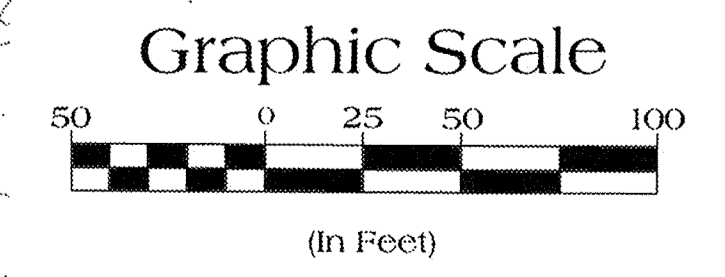

1 inch = 50 feet
 Representative Fraction 1:600
 Contour Interval - 1 foot

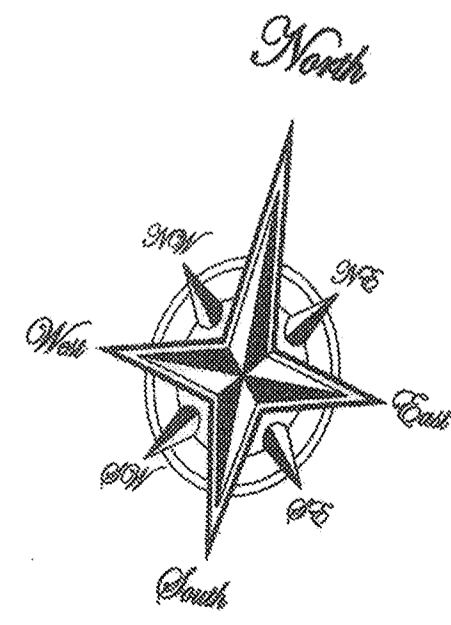

Signature of Texas Licensed Geologist
 Chris Wickman, P.G. Lic. # 10403

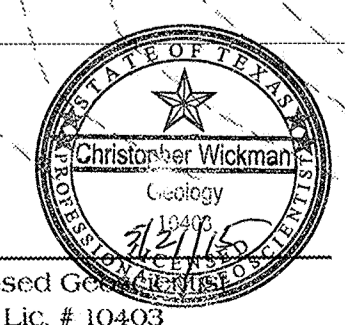

Fault Information Obtained From:
 Bureau of Economic Geology, Geologic Atlas of Texas, San Antonio Sheet (1983)
 U.S. Geological Survey, Water Resources Investigations Report
 Geologic Map of the New Braunfels, Texas 30 X 60 Minute Quadrangle (2000)

Floodplain Information Obtained From
 FIRMs: Flood Insurance Rate Map
 Bexar County, Texas: Panel # 48029C0230G, Revised 9/29/2010

– **Organized Sewage Collection System Plan (TCEQ-0582)**

Attachment A – SCS Engineering Design Report

Attachment B – Justification and Calculations for Deviation in Straight Alignment Without Manholes

Attachment C – Justification for Variance from Maximum Manhole Spacing

Attachment D – Calculations for Slopes for Flows Greater Than 10.0 Feet Per Second

Site Plan

Final Plan and Profile Sheets

Organized Sewage Collection System Application

Texas Commission on Environmental Quality

For Regulated Activities on the Edwards Aquifer Recharge Zone and Relating to 30 TAC §213.5(c), Effective June 1, 1999

To ensure that the application is administratively complete, confirm that all fields in the form are complete, verify that all requested information is provided, consistently reference the same site and contact person in all forms in the application, and ensure forms are signed by the appropriate party.

Note: Including all the information requested in the form and attachments contributes to more streamlined technical reviews.

Regulated Entity Name: Landmark North - West

1. **Attachment A – SCS Engineering Design Report.** This Engineering Design Report is provided to fulfill the requirements of 30 TAC Chapter 217, including 217.10 of Subchapter A, §§217.51 – 217.70 of Subchapter C, and Subchapter D as applicable, and is required to be submitted with this SCS Application Form.

Customer Information

2. The entity and contact person responsible for providing the required engineering certification of testing for this sewage collection system upon completion (including private service connections) and every five years thereafter to the appropriate TCEQ region office pursuant to 30 TAC §213.5(c) is:

Contact Person: Benjamn Dreszer

Entity: IH10/Loop 1604 Partners, LTD.

Mailing Address: 10003 NW Military Hwy, Suite 2205

City, State: San Antonio, Texas

Zip: 78231

Telephone: (210) 593-0777

Fax: (210) 593-0780

Email Address: benjamin@fulcrumsa.com

The appropriate regional office must be informed of any changes in this information within 30 days of the change.

3. The engineer responsible for the design of this sewage collection system is:

Contact Person: Richard Hendrix, P.E.

Texas Licensed Professional Engineer's Number: 107385

Entity: MBC Engineers

Mailing Address: 1035 Central Parkway North

City, State: San Antonio, Texas

Zip: 78232

Telephone: (210) 545-1122

Fax: (210) 545-9302

Email Address: rhendrix@mbcengineers.com

Project Information

4. Anticipated type of development to be served (estimated future population to be served, plus adequate allowance for institutional and commercial flows):

- Residential: Number of single-family lots: _____
 Multi-family: Number of residential units: _____
 Commercial
 Industrial
 Off-site system (not associated with any development)
 Other: _____

5. The character and volume of wastewater is shown below:

100% Domestic 21,900 gallons/day
N/A% Industrial 0 gallons/day
N/A% Commingled 0 gallons/day
 Total gallons/day: 21,900

6. Existing and anticipated infiltration/inflow is 2,370 gallons/day. This will be addressed by: storm and roof drains, etc. will not be connected to the SCS, construction of the SCS will not be below groundwater level and manholes will be watertight. Per SAWS USR 113.1, in sizing wastewater mains external contributions must be counted 300 gallons/acre.

7. A Water Pollution Abatement Plan (WPAP) is required for construction of any associated commercial, industrial or residential project located on the Recharge Zone.

- The WPAP application for this development was approved by letter dated _____. A copy of the approval letter is attached.
 The WPAP application for this development was submitted to the TCEQ on August 4, 2023, but has not been approved.
 A WPAP application is required for an associated project, but it has not been submitted.
 There is no associated project requiring a WPAP application.

8. Pipe description:

Table 1 - Pipe Description

<i>Pipe Diameter(Inches)</i>	<i>Linear Feet (1)</i>	<i>Pipe Material (2)</i>	<i>Specifications (3)</i>
8"		PVC, SDR 26, CL 115	ASTM D-3034
8"	385	PVC, SDR 26, CL 160	ASTM D-2241
6"		PVC, SDR 26, CL 115	ASTM D-3034
6"	230	PVC, SDR 26, CL 160	ASTM D-2241
4"	315	PVC, SDR 26, CL 160	ASTM D-2241

Total Linear Feet: 930

(1) Linear feet - Include stub-outs and double service connections. Do not include private service laterals.

- (2) Pipe Material - If PVC, state SDR value.
 - (3) Specifications - ASTM / ANSI / AWWA specification and class numbers should be included.
9. The sewage collection system will convey the wastewater to the Steven M. Clouse (name) Treatment Plant. The treatment facility is:

- Existing
- Proposed

10. All components of this sewage collection system will comply with:

- The City of San Antonio (SAWS) standard specifications.
- Other. Specifications are attached.

11. No force main(s) and/or lift station(s) are associated with this sewage collection system.
- A force main(s) and/or lift station(s) is associated with this sewage collection system and the **Lift Station/Force Main System Application** form (TCEQ-0624) is included with this application.

Alignment

12. There are no deviations from uniform grade in this sewage collection system without manholes and with open cut construction.
13. There are no deviations from straight alignment in this sewage collection system without manholes.
- Attachment B - Justification and Calculations for Deviation in Straight Alignment without Manholes.** A justification for deviations from straight alignment in this sewage collection system without manholes with documentation from pipe manufacturer allowing pipe curvature is attached.
- For curved sewer lines, all curved sewer line notes (TCEQ-0596) are included on the construction plans for the wastewater collection system.

Manholes and Cleanouts

14. Manholes or clean-outs exist at the end of each sewer line(s). These locations are listed below: (Please attach additional sheet if necessary)

Table 2 - Manholes and Cleanouts

<i>Line</i>	<i>Shown on Sheet</i>	<i>Station</i>	<i>Manhole or Clean-out?</i>
Line 'A'	Of	1+00.00	Manhole
Line 'A'	Of	1+87.15	Manhole
Lateral	Of	3+33.08	Cleanout
	Of		
	Of		
	Of		

<i>Line</i>	<i>Shown on Sheet</i>	<i>Station</i>	<i>Manhole or Clean-out?</i>
	Of		
	Of		
	Of		
	Of		

15. Manholes are installed at all Points of Curvature and Points of Termination of a sewer line.
16. The maximum spacing between manholes on this project for each pipe diameter is no greater than:

Pipe Diameter (inches)	Max. Manhole Spacing (feet)
6 - 15	500
16 - 30	800
36 - 48	1000
≥54	2000

- Attachment C – Justification for Variance from Maximum Manhole Spacing.** The maximum spacing between manholes on this project (for each pipe diameter used) is greater than listed in the table above. A justification for any variance from the maximum spacing is attached, and must include a letter from the entity which will operate and maintain the system stating that it has the capability to maintain lines with manhole spacing greater than the allowed spacing.
17. All manholes will be monolithic, cast-in-place concrete.
- The use of pre-cast manholes is requested for this project. The manufacturer's specifications and construction drawings, showing the method of sealing the joints, are attached.

Site Plan Requirements

Items 18 - 25 must be included on the Site Plan.

18. The Site Plan must have a minimum scale of 1" = 400'.
Site Plan Scale: 1" = 50'.
19. The Site Plan must include the sewage collection system general layout, including manholes with station numbers, and sewer pipe stub outs (if any). Site plan must be overlain by topographic contour lines, using a contour interval of not greater than ten feet and showing the area within both the five-year floodplain and the 100-year floodplain of any drainage way.
20. Lateral stub-outs:
- The location of all lateral stub-outs are shown and labeled.

- No lateral stub-outs will be installed during the construction of this sewer collection system.

21. Location of existing and proposed water lines:

- The entire water distribution system for this project is shown and labeled.
- If not shown on the Site Plan, a Utility Plan is provided showing the entire water and sewer systems.
- There will be no water lines associated with this project.

22. 100-year floodplain:

- After construction is complete, no part of this project will be in or cross a 100-year floodplain, either naturally occurring or manmade. (Do not include streets or concrete-lined channels constructed above of sewer lines.)
- After construction is complete, all sections located within the 100-year floodplain will have water-tight manholes. These locations are listed in the table below and are shown and labeled on the Site Plan. (Do not include streets or concrete-lined channels constructed above sewer lines.)

Table 3 - 100-Year Floodplain

<i>Line</i>	<i>Sheet</i>	<i>Station</i>
N/A	of	to
	of	to
	of	to
	of	to

23. 5-year floodplain:

- After construction is complete, no part of this project will be in or cross a 5-year floodplain, either naturally occurring or man-made. (Do not include streets or concrete-lined channels constructed above sewer lines.)
- After construction is complete, all sections located within the 5-year floodplain will be encased in concrete or capped with concrete. These locations are listed in the table below and are shown and labeled on the Site Plan. (Do not include streets or concrete-lined channels constructed above sewer lines.)

Table 4 - 5-Year Floodplain

<i>Line</i>	<i>Sheet</i>	<i>Station</i>
N/A	of	to
	of	to
	of	to
	of	to

- 24. Legal boundaries of the site are shown.

25. The **final plans and technical specifications** are submitted for the TCEQ's review. Each sheet of the construction plans and specifications are dated, signed, and sealed by the Texas Licensed Professional Engineer responsible for the design on each sheet.

Items 26 - 33 must be included on the Plan and Profile sheets.

26. All existing or proposed water line crossings and any parallel water lines within 9 feet of sewer lines are listed in the table below. These lines must have the type of pressure rated pipe to be installed shown on the plan and profile sheets. Any request for a variance from the required pressure rated piping at crossings must include a variance approval from 30 TAC Chapter 290.

There will be no water line crossings.

There will be no water lines within 9 feet of proposed sewer lines.

Table 5 - Water Line Crossings

<i>Line</i>	<i>Station or Closest Point</i>	<i>Crossing or Parallel</i>	<i>Horizontal Separation Distance</i>	<i>Vertical Separation Distance</i>
Line 'A'	1+43.99	Crossing		5.99'

27. Vented Manholes:

No part of this sewer line is within the 100-year floodplain and vented manholes are not required by 30 TAC Chapter 217.

A portion of this sewer line is within the 100-year floodplain and vented manholes will be provided at less than 1500 foot intervals. These water-tight manholes are listed in the table below and labeled on the appropriate profile sheets.

A portion of this sewer line is within the 100-year floodplain and an alternative means of venting shall be provided at less than 1500 feet intervals. A description of the alternative means is described on the following page.

A portion of this sewer line is within the 100-year floodplain; however, there is no interval longer than 1500 feet located within. No vented manholes will be used.

Table 6 - Vented Manholes

<i>Line</i>	<i>Manhole</i>	<i>Station</i>	<i>Sheet</i>
N/A			

<i>Line</i>	<i>Manhole</i>	<i>Station</i>	<i>Sheet</i>

28. Drop manholes:

- There are no drop manholes associated with this project.
- Sewer lines which enter new or existing manholes or "manhole structures" higher than 24 inches above the manhole invert are listed in the table below and labeled on the appropriate profile sheets. These lines meet the requirements of 30 TAC §217.55(l)(2)(H).

Table 7 - Drop Manholes

<i>Line</i>	<i>Manhole</i>	<i>Station</i>	<i>Sheet</i>
N/A			

29. Sewer line stub-outs (For proposed extensions):

- The placement and markings of all sewer line stub-outs are shown and labeled.
- No sewer line stub-outs are to be installed during the construction of this sewage collection system.

30. Lateral stub-outs (For proposed private service connections):

- The placement and markings of all lateral stub-outs are shown and labeled.
- No lateral stub-outs are to be installed during the construction of this sewage collection system.

31. Minimum flow velocity (From Appendix A)

- Assuming pipes are flowing full; all slopes are designed to produce flows equal to or greater than 2.0 feet per second for this system/line.

32. Maximum flow velocity/slopes (From Appendix A)

- Assuming pipes are flowing full, all slopes are designed to produce maximum flows of less than or equal to 10 feet per second for this system/line.
- Attachment D – Calculations for Slopes for Flows Greater Than 10.0 Feet per Second.** Assuming pipes are flowing full, some slopes produce flows which are greater than 10 feet per second. These locations are listed in the table below. Calculations are attached.

Table 8 - Flows Greater Than 10 Feet per Second

<i>Line</i>	<i>Profile Sheet</i>	<i>Station to Station</i>	<i>FPS</i>	<i>% Slope</i>	<i>Erosion/Shock Protection</i>
N/A					

33. Assuming pipes are flowing full, where flows are ≥ 10 feet per second, the provisions noted below have been made to protect against pipe displacement by erosion and/or shock under 30 TAC §217.53(l)(2)(B).

- Concrete encasement shown on appropriate Plan and Profile sheets for the locations listed in the table above.
- Steel-reinforced, anchored concrete baffles/retards placed every 50 feet shown on appropriate Plan and Profile sheets for the locations listed in the table above.
- N/A

Administrative Information

34. The final plans and technical specifications are submitted for TCEQ review. Each sheet of the construction plans and specifications are dated, signed, and sealed by the Texas Licensed Professional Engineer responsible for the design on each sheet.
35. Standard details are shown on the detail sheets, which are dated, signed, and sealed by the Texas Licensed Professional Engineer, as listed in the table below:

Table 9 - Standard Details

<i>Standard Details</i>	<i>Shown on Sheet</i>
Lateral stub-out marking [Required]	N/A of
Manhole, showing inverts comply with 30 TAC §217.55(l)(2) [Required]	S5.00 of
Alternate method of joining lateral to existing SCS line for potential future connections [Required]	N/A of
Typical trench cross-sections [Required]	S5.02 of
Bolted manholes [Required]	S5.00 of
Sewer Service lateral standard details [Required]	S5.01 of
Clean-out at end of line [Required, if used]	S5.01 of
Baffles or concrete encasement for shock/erosion protection [Required, if flow velocity of any section of pipe >10 fps]	N/A of
Detail showing Wastewater Line/Water Line Crossing [Required, if crossings are proposed]	S5.00 of
Mandrel detail or specifications showing compliance with 30 TAC §217.57(b) and (c) [Required, if Flexible Pipe is used]	S5.01 of

<i>Standard Details</i>	<i>Shown on Sheet</i>
Drop manholes [Required, if a pipe entering a manhole is more than 24 inches above manhole invert]	N/A of

- 36. All organized sewage collection system general construction notes (TCEQ-0596) are included on the construction plans for this sewage collection system.
- 37. All proposed sewer lines will be sufficiently surveyed/staked to allow an assessment prior to TCEQ executive director approval. If the alignments of the proposed sewer lines are not walkable on that date, the application will be deemed incomplete and returned.
 - Survey staking was completed on this date: TBD
- 38. Submit one (1) original and one (1) copy of the application, plus additional copies as needed for each affected incorporated city, groundwater conservation district, and county in which the project will be located. The TCEQ will distribute the additional copies to these jurisdictions. The copies must be submitted to the appropriate regional office.
- 39. Any modification of this SCS application will require TCEQ approval, prior to construction, and may require submission of a revised application, with appropriate fees.

Signature

To the best of my knowledge, the responses to this form accurately reflect all information requested concerning the proposed regulated activities and methods to protect the Edwards Aquifer. This **Organized Sewage Collection System Application** is hereby submitted for TCEQ review and executive director approval. The system was designed in accordance with the requirements of 30 TAC §213.5(c) and 30 TAC §217 and prepared by:

Print Name of Licensed Professional Engineer: Richard Hendrix, P.E.

Date: 10/19/2023

Place engineer's seal here:



Signature of Licensed Professional Engineer

R.W. Hendrix

Appendix A-Flow Velocity Table

Flow Velocity (Flowing Full) All gravity sewer lines on the Edwards Aquifer Recharge Zone shall be designed and constructed with hydraulic slopes sufficient to give a velocity when flowing full of not less than 2.0 feet per second, and not greater than 10 feet per second. The grades shown in the following table are based on Manning's formula and an n factor of 0.013 and shall be the minimum and maximum acceptable slopes unless provisions are made otherwise.

Table 10 - Slope Velocity

Pipe Diameter(Inches)	% Slope required for minimum flow velocity of 2.0 fps	% Slope which produces flow velocity of 10.0 fps
6	0.50	12.35
8	0.33	8.40
10	0.25	6.23
12	0.20	4.88
15	0.15	3.62
18	0.11	2.83
21	0.09	2.30
24	0.08	1.93
27	0.06	1.65
30	0.055	1.43
33	0.05	1.26
36	0.045	1.12
39	0.04	1.01
>39	*	*

*For lines larger than 39 inches in diameter, the slope may be determined by Manning's formula (as shown below) to maintain a minimum velocity greater than 2.0 feet per second when flowing full and a maximum velocity less than 10 feet per second when flowing full.

$$v = \frac{1.49}{n} \times R_h^{0.67} \times \sqrt{S}$$

Figure 1 - Manning's Formula

Where:

v = velocity (ft/sec)

n = Manning's roughness coefficient (0.013)

R_h = hydraulic radius (ft)

S = slope (ft/ft)

FORM 0582 ATTACHMENT

ATTACHMENT “A” – SCS Engineering Design Report

Please see SCS Engineering Design Report included in the SCS Plan

ATTACHMENT “B” – Justification and Calculations for Deviation in Straight Alignment Without Manholes

Not Applicable

ATTACHMENT “C” – Justification for Variance from Maximum Manhole Spacing

Not Applicable

ATTACHMENT “D” – Calculations for Slopes for Flows Greater Than 10.0 Feet Per Second

Not Applicable

TABLE OF CONTENTS

<u>PROJECT INFORMATION</u>	2
<u>GRAVITY SANITARY SEWER PIPING: FLOW & CAPACITY ANALYSIS</u>	2
<u>Odor Control</u>	3
<u>Flow Calculation</u>	3
<u>Capacity Calculation</u>	3
<u>Conclusion</u>	5
<u>GENERAL STRUCTURAL COMPONENTS</u>	6
<u>Project Materials (Pipe and Joints):</u>	6
<u>Project Materials (Bedding):</u>	6
<u>Project Materials (Manholes):</u>	7
<u>Project Materials (Manhole Covers):</u>	7
<u>Minimum and Maximum Slopes</u>	7
<u>Backfill</u>	7
<u>Trenching</u>	8
<u>Minimum and Maximum Trench Width</u>	8
<u>Corrosion Prevention</u>	8
<u>Manholes (General)</u>	8
<u>Manholes (Inverts)</u>	9
<u>Manholes (Ventilation)</u>	9
<u>FLEXIBLE PIPE COMPUTATIONS</u>	9
<u>Live Load Calculations</u>	9
<u>Buckling Pressure Calculations</u>	9
<u>Allowable Buckling Pressure:</u>	9
<u>Pressure Under Installed Conditions</u>	11
<u>Wall Crushing Calculations</u>	11
<u>Installation Temperature Effects</u>	12
<u>Tensile Strength</u>	12
<u>Strain</u>	12
<u>Modulus of Soil Reaction</u>	12
<u>Zeta Calculation</u>	13
<u>Pipe Stiffness</u>	14
<u>Deflection</u>	14

**LANDMARK NORTH - WEST RETAIL – SEWER COLLECTION SYSTEM
ENGINEERING REPORT**

This Engineering Design Report has been prepared to comply with the Texas Commission on Environmental Quality’s Design Criteria for Domestic Wastewater Systems (30 TAC 217), and regulations over the Edwards Aquifer Recharge Zone (30 TAC 213). Please note that throughout this application, the more stringent of SAWS or TCEQ regulations shall apply.

PROJECT INFORMATION

The proposed site is located southeast of the intersection of IH 10 and Loop 1604 within the overall Landmark development. The Landmark North-West Sewer Collection System construction will consist of 385 linear feet of private sanitary sewer main (size: 8”), 315 linear feet of private force main (size 6”) and 230 linear feet of private sanitary sewer lateral (size: 6”). The public sewer main will be connected to an existing public sewer system that is located south of the subject tract. The existing 8” main is located within an existing sewer easement on private property.

The overall tract which the sewer collection system will serve is approximately 12.139 acres and a portion of the overall site is located within the Edwards Aquifer Recharge Zone. The “site area” which is considered to be a 100’ envelope around the proposed sewer alignment is approximately 2.5 acres.

This project is located within the city limits of San Antonio and San Antonio Water Systems (SAWS) will supply potable water to the project. Approximately 21,900 gallons per day of domestic wastewater is estimated to be generated by this development and will be discharged into the proposed SCS. This daily flow value accounts for the peak flow and external contributions as required by the San Antonio Water System Utility Service Regulations 11.3.1. Wastewater is disposed of by conveyance to the existing Steven M. Clouse Water Recycling Center operated by SAWS.

Please refer to the overall site plan of the attached sewer plans, which show the proposed service area and its topographic features. There are no current plans for future expansion at this time. For information regarding the capability of the existing system and facilities to handle this increased flow, please see copy of the SAWS Utility Service Agreement (USA) attached. This system is designed to have a minimum structural life of 50 years. Safety considerations are the responsibility of the contractor. Refer to SAWS Item Nos. 550 and 902 for construction safety information. Safety protection shall be accomplished in accordance with the most recent requirements of the Occupational Safety and Health Administration Standards and Interpretations.

GRAVITY SANITARY SEWER PIPING: FLOW & CAPACITY ANALYSIS

Basis for average flow used for design of collection system (**check one or more**):

Per Capita Contributions: _____

Service Connections: _____

Land Area and Use: $\sqrt{\hspace{1.5cm}}$

**LANDMARK NORTH - WEST RETAIL – SEWER COLLECTION SYSTEM
ENGINEERING REPORT**

Fixture Analysis: _____

Odor Control

Odor Control is not necessary on this project throughout its expected 50-year life cycle as it is a gravity line and there will be no conditions where sewage is standing and will become septic.

Flow Calculation

Peaking Factor used for design: 2.5

Peaking Factor is based on: SAWS Specifications for peak dry weather flow (from SAWS USR 11.3.1)

Please note that capacities are determined using Manning's equation for pipes flowing full with an "n" value of 0.013. A reference for Manning's Equation can be found in "The Uni-Bell Handbook of PVC Pipe: Design and Construction".

Per SAWS EDU Calculation Sheet:

60 EDUS

$$\begin{aligned} 1 \text{ EDU} &= 200 \text{ gallons per day (average sewage flow)} \\ &= 500 \text{ gallons per day (peak flow)} \end{aligned}$$

Per SAWS USR 11.3.1, in sizing wastewater mains external contributions must be accounted by including 600 gallons per acre served for inflow and infiltration.

Inflow & Infiltration = 7.903 acres x 600 gallon/acre = 4,740 gallons

$$\text{Total EDUs} = \underline{60} \text{ EDUs}$$

$$\text{Avg. Flow} = \underline{60} \text{ EDUs} \times (200 \text{ gpd/EDU}) = \underline{12,000} \text{ gpd} + \underline{4,740} \text{ gpd} = \underline{11.63} \text{ gpm}$$

$$\text{Peak Flow} = \underline{60} \text{ EDUs} \times (500 \text{ gpd/EDU}) = \underline{30,000} \text{ gpd} + \underline{4,740} \text{ gpd} = \underline{24.13} \text{ gpm}$$

Capacity Calculation

Characteristics of 8" ASTM D3034, Class 115, SDR 26, PVC Sewer Pipe:

Nominal Size = 8"

Outer Diameter (D_o) = 8.40"

Minimum Wall Thickness (t) = 0.323"

Inner Diameter (D_i) = 7.75"

Characteristics of 8" ASTM 2241, SDR 26, PVC Sewer Pipe:

Nominal Size = 8"

Outer Diameter (D_o) = 8.625"

**LANDMARK NORTH - WEST RETAIL – SEWER COLLECTION SYSTEM
ENGINEERING REPORT**

Minimum Wall Thickness (t) = 0.332"

Inner Diameter (D_i) = 7.961"

Manning's Equation:

$$Q = (k/n)(A)(R^{2/3})(S^{1/2})$$

$$v = Q/A$$

Where:

Q = Discharge (cfs)

k = Constant [(1.49 ft^{1/3})/sec.]

n = Manning's roughness coefficient (unitless)

A = Flow area (ft²)

R = Hydraulic Radius (ft)

= A/P = Cross sectional area of flow (ft²)/Wetted perimeter (ft.)

S = Slope (ft/ft)

v = Velocity of flow (ft/s)

$n = 0.013$ [as required by 30 TAC 213.53 A (i)]

Calculations for 8" ASTM D3034, SDR 26, PVC Sewer Pipe:

$$A = \pi(D_i^2)/4 = \pi(7.75 \text{ in})^2/4 = 47.17 \text{ in}^2 = 0.33 \text{ ft}^2$$

$$P = \pi(D_i) = \pi(7.75 \text{ in}) = 24.35 \text{ in} = 2.03 \text{ ft}$$

$$R = A/P = 0.33 \text{ ft}^2/2.03 \text{ ft} = 0.16 \text{ ft}$$

$$S = 0.004$$

$$Q = [(1.49 \text{ ft}^{1/3}/\text{sec})/0.013](0.33 \text{ ft}^2)(0.16 \text{ ft})^{2/3}(0.004)^{1/2}$$

$$Q = 0.705 \text{ cfs} = 316 \text{ gpm} = Q_{full}$$

$$v = 0.705 \text{ cfs}/0.33 \text{ ft}^2 = \mathbf{2.14 \text{ ft/s}}$$

$$Q_{max} = 0.705 \text{ cfs} (0.90)(7.48 \text{ gallons/1 cf})(60 \text{ sec/1 min.}) = \mathbf{284.8 \text{ gpm}}$$

Calculations for 8" ASTM 2241, SDR 26, PVC Sewer Pipe:

$$A = \pi(D_i^2)/4 = \pi(7.961 \text{ in})^2/4 = 49.78 \text{ in}^2 = 0.35 \text{ ft}^2$$

$$P = \pi(D_i) = \pi(7.961 \text{ in}) = 25.01 \text{ in} = 2.08 \text{ ft}$$

$$R = A/P = 0.35 \text{ ft}^2/2.08 \text{ ft} = 0.17 \text{ ft}$$

$$S = 0.004$$

$$Q = [(1.49 \text{ ft}^{1/3}/\text{sec})/0.013](0.35 \text{ ft}^2)(0.17 \text{ ft})^{2/3}(0.004)^{1/2}$$

$$Q = 0.779 \text{ cfs} = 349.6 \text{ gpm} = Q_{full}$$

**LANDMARK NORTH - WEST RETAIL – SEWER COLLECTION SYSTEM
ENGINEERING REPORT**

$$v = 0.87 \text{ cfs}/0.35 \text{ ft}^2 = \mathbf{2.49 \text{ ft/s}}$$

$$Q_{max} = 0.779 \text{ cfs} (0.90)(7.48 \text{ gallons}/1 \text{ cf})(60 \text{ sec}/1 \text{ min.}) = \mathbf{314.6 \text{ gpm}}$$

Velocity Calculation

$$V = (1.49/n)(R^{2/3})(S^{1/2})$$

Calculations for 8" ASTM D3034, SDR 26, PVC Sewer Pipe:

$$A = \pi(D_i^2)/4 = \pi(7.75 \text{ in})^2/4 = 47.17 \text{ in}^2 = 0.33 \text{ ft}^2$$

$$P = \pi(D_i) = \pi(7.75 \text{ in}) = 24.35 \text{ in} = 2.03 \text{ ft}$$

$$R = A/P = 0.33 \text{ ft}^2/2.03 \text{ ft} = 0.16 \text{ ft}$$

$$S = 0.08$$

$$V = [(1.49 \text{ ft}^{1/3}/\text{sec})/0.013] (0.16 \text{ ft})^{2/3} (0.08)^{1/2}$$

$$v = \mathbf{9.55 \text{ ft/s}}$$

$$V_{max} = \mathbf{9.55 \text{ ft/s} < 10 \text{ ft/s (allowable)}}$$

Calculations for 8" ASTM 2241, SDR 26, PVC Sewer Pipe:

$$A = \pi(D_i^2)/4 = \pi(7.961 \text{ in})^2/4 = 49.78 \text{ in}^2 = 0.35 \text{ ft}^2$$

$$P = \pi(D_i) = \pi(7.961 \text{ in}) = 25.01 \text{ in} = 2.08 \text{ ft}$$

$$R = A/P = 0.35 \text{ ft}^2/2.08 \text{ ft} = 0.17 \text{ ft}$$

$$S = 0.08$$

$$V = [(1.49 \text{ ft}^{1/3}/\text{sec})/0.013] (0.17 \text{ ft})^{2/3} (0.08)^{1/2}$$

$$v = \mathbf{9.95 \text{ ft/s}}$$

$$V_{max} = \mathbf{9.95 \text{ ft/s} < 10.0 \text{ ft/s (allowable)}}$$

Nominal Main Size (in)	Outer Diameter (in)	Minimum Slope	Area (ft ²)	Hydraulic Radius (A/P)	R ^{2/3}	S ^{1/2}	Q-Full (cfs)	Max Pipe (%)	Velocity (ft/s)	Q-Max (gpm)
8	8.40	0.004	0.33	0.16	0.29	0.063	0.705	90	2.49	284.8
8	8.625	0.004	0.35	0.17	0.31	0.063	0.779	90	2.14	314.6

Conclusion

The proposed 8" pipe with a minimum slope of 0.4% both have sufficient capacity to convey the projected average and peak flows.

GENERAL STRUCTURAL COMPONENTS

Project Materials (Pipe and Joints):

Nominal Pipe Diameter (in)	Linear Feet	Pipe Material	National Standard Specification for Pipe Material	National Standard for Pipe Joints
<i>8</i>	<i>385</i>	<i>PVC SDR 26</i>	<i>ASTM 2241</i>	<i>ASTM D3139</i>

Note: Section 217.53 (j)(4) requires a minimum pipe diameter of 6 inches for all gravity sanitary sewer collection system piping.

Watertight, size on size resilient connectors conforming to ASTM C-923 have been specified for connecting pipe to manholes. See SAWS Standard Specification for Construction Detail DD-852-01.

Where a collection system parallels a water supply pipe and a nine-foot separation distance cannot be achieved, Section 217.53 (d)(3)(A)(i) requires a collection system pipe be constructed of cast iron, ductile iron, or PVC meeting ASTM specifications with at least a 150 pounds per square inch (psi) rating for both the pipe and joints. The proposed project will comply with these requirements.

Where a collection system pipe crosses a water supply line and a nine-foot separation distance cannot be achieved, Section 217.53(d)(3)(B)(i) requires the collection system pipe be constructed of cast iron, ductile iron, or PVC with a minimum pressure rating of 150 psi. The proposed project will comply with this requirement and that of 30 TAC 217.53(d)(3)(B)(iii).

Project Materials (Bedding):

The specified bedding will comply with ASTM D-2321 Class IA, IB, II or III for materials and densification. A minimum of 6 inches of bedding is required for all pipe.

Pipe Diameter (in)	Pipe Material	Bedding Class
<i>8</i>	<i>PVC</i>	<i>Class IA & Class III</i>

The selection of bedding class is based on SAWS detail DD-804-01 for sanitary sewer pipe laid in a trench. Initial backfill for the pipe sizes shown above will be Class IA. Secondary backfill will be Class III. See Table 1 of ASTM D2323-05 “Classes of Embedment and Backfill Material” in Appendix B.

**LANDMARK NORTH - WEST RETAIL – SEWER COLLECTION SYSTEM
ENGINEERING REPORT**

Project Materials (Manholes):

Section 217.55 (f) prohibits the use of bricks to adjust a manhole cover to grade or construct a manhole. The proposed project will comply with this requirement.

The inside diameter of a manhole must be no less than 48 inches.

Section 217.55 (n) requires watertight, size-on-size resilient connectors that allow for differential settlement and must conform to American Society for Testing and Materials C-923. The proposed project complies with this requirement.

Under 30 TAC 213.5(C)(3)(A), all manholes over the Recharge Zone must be watertight, with watertight rings and covers. The proposed project complies with this requirement.

The materials specified for manhole construction are **precast concrete**.

Project Materials (Manhole Covers):

Manhole covers must be constructed of impervious materials. If personnel entry is required, a minimum 30-inch diameter clear opening must be provided. Inclusion of steps in a manhole is prohibited. If a manhole must be located within a 100-year flood plain then a means of preventing inflow is required. A manhole cover that is located in a roadway must meet or exceed the American Association of State Highways and Transportation Officials Standard M-306 for load bearing.

Under 30 TAC 213.5 (c)(3)(A), all manholes over the Edwards Aquifer Recharge Zone must be watertight, with watertight rings and covers. This proposed project complies with this requirement.

Minimum and Maximum Slopes

Note: All pipes are designed with a slope that will provide a velocity of at least 2 ft/s flowing full, as calculated using Manning's equation with an "n" value of 0.013. Concrete encasement is provided where flows greater than 10 ft/s are produced.

The following are the minimum and maximum slopes for each pipe diameter:

Pipe Diameter: 8" Min. Slope: 0.500% Max. Slope: 1.000% (Allowable Min. 0.33% - Max. 8.40%)

Backfill

Note: The backfill will be free of stones greater than 6 inches in diameter and free of organic or any other unstable material. See SAWS Item No. 804 for additional specifications.

**LANDMARK NORTH - WEST RETAIL – SEWER COLLECTION SYSTEM
ENGINEERING REPORT**

Trenching

Note: The trench width will be minimized while still allowing adequate width for proper compaction of backfill, and while still ensuring that at least 6 inches of backfill exists below and on each side of the pipe. The trench walls will be vertical to at least one foot above the pipe.

Trenching will occur over the Recharge Zone and will comply with 30 TAC 213.5.

Minimum and Maximum Trench Width

Based on SAWS Standard Drawing DD-804-01 and 30 TAC 217.54:

Pipe Diameter: 8" Min. Trench Width: 23" Max. Trench Width: 33"

These trench widths account for the bell diameter.

Corrosion Prevention

Proposed collection system components (pipes, manholes, etc.) will not be susceptible to deterioration through the corrosive effects of an anaerobic sewage environment for the duration of the 50-year design life cycle as there will be no conditions where the sewer will become septic and the development of hydrogen sulfide would cause corrosion.

Manholes (General)

Note: Manholes are provided at all changes in size, grade or alignment of pipe, at the intersection of all pipes and at the end of all lines that may be extended at a future date. A clean-out with watertight plugs may be installed instead of a manhole if no extensions are anticipated. Clean outs must pass all testing requirements outlined for gravity collection pipes.

The project complies with the maximum manhole spacing allowed by the TCEQ:

Pipe Diameter (in)	Max. Manhole Spacing (ft)
6 - 15	500
18 - 30	800
36 - 48	1000
54 or larger	2000

Manhole Spacing:

Pipe Diameter: 8" Max. Spacing: 309.53L.F.

Manholes (Inverts)

The bottom of a manhole must contain a U-shaped channel which is a smooth continuation of the inlet and outlet pipes. The bench above the channel must be sloped a minimum of 0.5 inches per foot. See SAWS detail DD-852-01 which complies with these requirements. Note, a manhole connected to a pipe less than 15 inches in diameter must have a channel depth equal to at least half the largest pipe's diameter.

Manholes (Ventilation)

No part of this sewer line is within the 100-year floodplain and vented manholes are not required by 30 TAC 217.

FLEXIBLE PIPE COMPUTATIONS

Please note, all flexible pipe computations are based on engineering principles and practices for the design of buried PVC pipe systems. Equations used can be found in “The Uni-Bell PVC Pipe Association Handbook of PVC Pipe: Design and Construction” or the “Buried Pipe Design, 3rd Edition” by Moser. Please note, the equations used may be in a different format than shown in in these books. Throughout this application “160 psi” pipe refers to the pressure rating of the ASTM 2241, Class 160, SDR 26 pipe used at water/sewer crossings.

Live Load Calculations

No influence of live loads on the performance of the SCS is anticipated. The average burial depth for this line is such that the influence of live loads is negligible.

Buckling Pressure Calculations

The value of h_w in these calculations refers specifically to perched groundwater over the pipe. Based on the topographical conditions for this site did not encounter ground water at the depths of the proposed sewer line construction. Therefore, a value of $h_w=0$ will be assumed for these calculations.

The value of H for use in these calculations is twenty (20) feet as it exceeds the maximum burial depth for this line (12.3 ft). The value of γ_s equals 143 pcf is a conservative value based on a dry unit weight of 135 pcf and moisture content of 6%. This value is conservative as it corresponds to saturated unit weights of commonly used backfill materials.

Allowable Buckling Pressure:

$$q_a = 0.4 * \sqrt[2]{32 * R_w * B' * E_b * (E * I / D^3)} \quad (\text{Equation 1})$$

**LANDMARK NORTH - WEST RETAIL – SEWER COLLECTION SYSTEM
ENGINEERING REPORT**

$$q_a = 0.4 * \sqrt[2]{32 * 1.0 * 0.48 * 1000 * (400,000 * 0.003 / 8.08^3)} = 74.77 \text{ psi (8" PVC SDR 26, ASTM 3034)}$$

$$q_a = 0.4 * \sqrt[2]{32 * 1.0 * 0.48 * 1000 * (400,000 * 0.003 / 8.29^3)} = 71.95 \text{ psi (8" PVC SDR 26, ASTM 2241)}$$

$$R_w = 1 - 0.33 * (h_w / h) \quad (\text{Equation 2})$$

$$R_w = 1 - 0.33 * (0 / 240) = 1.0$$

$$B' = \frac{I}{1 + 4 * e^{-0.065H}} \quad (\text{Equation 3})$$

$$B' = \frac{I}{1 + 4 * e^{-0.065(20)}} = 0.48$$

$$I = (t^3 / 12) * (\text{inches}^4 / \text{linear inch}) \quad (\text{Equation 4})$$

$$I = (0.323^3 / 12) = 0.003 \text{ in}^3 \text{ (8" PVC, SDR 26, ASTM 3034)}$$

$$I = (0.332^3 / 12) = 0.003 \text{ in}^3 \text{ (8" PVC, SDR 26, ASTM 2241)}$$

$$D = D_o - t \quad (\text{Equation 5})$$

$$D = 8.40 \text{ inches} - 0.323 \text{ inches} = 8.08 \text{ inches (8" PVC, SDR 26, ASTM 3034)}$$

$$D = 8.625 \text{ inches} - 0.332 \text{ inches} = 8.29 \text{ inches (8" PVC, SDR 26, ASTM 2241)}$$

Where:

- q_a = allowable buckling pressure, pounds per square inch (psi)
- h = height of soil surface above top of pipe in inches (in) **[20 feet or 240 inches]**
- h_w = height of water surface above top of pipe in inches (in)
- R_w = Water buoyancy factor. If h_w = 0, R_w = 1. If 0 ≤ h_w ≤ h (groundwater elevation is between the top of the pipe and the ground surface), calculate R_w with Equation 2
- H = Depth of burial in feet (ft) from ground surface to crown of pipe.
- B' = Empirical coefficient of elastic support
- E_b = modulus of soil reaction for the bedding material (psi)
- E = modulus of elasticity of the pipe material (psi)
- I = moment of inertia of the pipe wall cross section per linear inch of pipe, inch⁴/lineal inch = inch³. For solid wall pipe, "I" can be calculated with Equation 4

**LANDMARK NORTH - WEST RETAIL – SEWER COLLECTION SYSTEM
ENGINEERING REPORT**

- t = pipe structural wall thickness (in)
D = mean pipe diameter (in)
D_o = pipe outer diameter (in)

Pressure Under Installed Conditions

$$q_p = \gamma_w * h_w + R_w * (W_c / D) + L_l \quad (\text{Equation 6})$$

$$q_p = (0.0361 * 0) + 1.0 * (166.89 / 8.08) + 0 = 20.65 \text{ psi (8" PVC SDR 26, ASTM 3034)}$$

$$q_p = 0.0361 * 0 + 1.0 * (171.24 / 8.29) + 0 = 20.66 \text{ psi (8" PVC SDR 26, ASTM 2241)}$$

Where:

- q_p = pressure applied to pipe under installed conditions (psi)
γ_w = 0.0361 pounds per cubic inch (pci), specific weight of water
W_c = vertical soil load on the pipe per unit length in pounds per linear inch (lb/in)
L_l = Live load

$$W_c = \gamma_s * H * (D + t) / 144 \quad (\text{Equation 7})$$

$$W_c = 143 * 20 * (8.08 + 0.323) / 144 = 166.89 \text{ lb/in (8" PVC SDR 26, ASTM 3034)}$$

$$W_c = 143 * 20 * (8.29 + 0.332) / 144 = 171.24 \text{ lb/in (8" PVC SDR 26, ASTM 2241)}$$

- γ_s = specific weight of soil in pounds per cubic foot (pcf)
D = mean pipe diameter (in)

Pipe Diameter: 8" (ASTM 3034) Pipe Material: PVC, SDR 26 q_a: 74.77 q_p: 20.65

Pipe Diameter: 8" (ASTM 2241) Pipe Material: PVC, SDR 26 q_a: 71.77 q_p: 20.66

Since q_a ≥ q_p, the specified pipe is acceptable for the proposed installation.

Wall Crushing Calculations

No concrete encased flexible pipe is proposed on this project; therefore, calculations are not required.

$$H = (24 * P_c * A) / (\gamma_s * D_o) \quad (\text{Equation 8})$$

$$A = t(\text{in}) \times 12(\text{in} / \text{ft}) \quad (\text{Equation 9})$$

- D_o = outside pipe diameter, in.

**LANDMARK NORTH - WEST RETAIL – SEWER COLLECTION SYSTEM
ENGINEERING REPORT**

- P_c = compressive stress or hydrostatic design basis (HDB). For typical PVC pipe assume 4,000 psi.
For any other pipe material the HDB must be supplied by the pipe manufacturer.
- A = surface area of the pipe wall, in.²/ft [conversion factor of 12 applied to change from ft. to in.]
- γ_s = specific weight of soil in pounds per cubic foot (pcf)
- H = Depth of burial in feet (ft) from ground surface to crown of pipe.
- 24 = conversions and coefficients

Installation Temperature Effects

Flexible pipe will be installed under favorable ambient conditions, per pipe manufacturer’s specifications.

Tensile Strength

The information below is from “The Uni-Bell Handbook of PVC Pipe: Design and Construction” Table 2.1 pages 14-15. This applies to all PVC SDR-26 pipe.

Pipe Material: PVC SDR-26 Tensile Strength: 7,000 Cell Class (PVC only) 12454

Strain

The conditions of this installation are such that strain-related failure will not be a problem. Strain is generally not a performance-limiting factor for buried PVC pipe or a design-limiting criterion for PVC pipes according to the Uni-Bell Handbook of PVC Pipe (Chapter VII, Pages 255 and 257). As pipe deflection will be below 5%, strain-related failure is not anticipated.

Modulus of Soil Reaction

The modulus of soil reaction for the bedding material, E_b , is 1,000 psi.

This value was determined using “Table 1: Classes of Embedment and Backfill Materials” from ASTM D2321-05 and “Average Values of Modulus of Soil Reaction, E” Table 7.3 from “The Uni-Bell Handbook of PVC Pipe: Design and Construction” attached at the end of Appendix B. Based on SAWS detail DD-804-01, Class III material was chosen. As the secondary backfill (Class III) has a lower Modulus of Soil Reaction than initial backfill (Class IA), its value was used in the calculations that follow. Class III on Table 1 corresponds to coarse-grained soils with fines (GM, SM or SC). On Table 7.3, coarse-grained soils with fines at a slight compaction have an E' equal to 400 psi.

The modulus of soil reaction for the in-situ soil, E'_n , is 1,000 psi

This value was determined using “Table 1: Classes of Embedment and Backfill Materials” from ASTM D 2321-05 and “Average Values of Modulus of Soil Reaction, E” Table 7.3 from “The Uni-Bell Handbook of PVC Pipe:

**LANDMARK NORTH - WEST RETAIL – SEWER COLLECTION SYSTEM
ENGINEERING REPORT**

Design and Construction” attached at the end of Appendix B. Based on SAWS detail DD-804-01, Class IA material was chosen, which includes crushed rock as shown on Table 1. Compacted crushed rock on Table 7.3 has an E' equal to 3,000 psi.

Values in Table 7.3 are based on empirical data and derived from laboratory and field tests for buried pipe.

Bedding to in-situ soil modulus of soil reaction ratio = $E_b/E'_n = \underline{1,000 \text{ psi}/1,000 \text{ psi} = 1.0}$

Zeta Calculation

Where native soil is significantly weaker than bedding material, or where predicted deflection approaches 5%, the effect of native soil must be quantified using Leonhardt's Zeta factor. If the ratio of bedding modulus to soil modulus is not equal to 1.0, a zeta factor must be calculated by using the equations below, where zeta is a factor which corrects for the effect of in-situ soil on pipe stability (Uni-Bell Handbook of Pipe, page 267). To calculate zeta, directly use the formulas below. The calculations that are done to determine the zeta factors for the different pipe diameters must be included with this submittal.

$$zeta = \frac{1.44}{f + (1.44 - f) * (E_b / E'_n)} \quad (\text{Equation 10})$$

$$zeta = \frac{1.44}{1.19 + (1.44 - 1.19) * (1.0)} = 1.0 \text{ (8" PVC SDR 26, ASTM 3034)}$$

$$zeta = \frac{1.44}{1.17 + (1.44 - 1.17) * (1.0)} = 1.0 \text{ (8" PVC SDR 26, ASTM 2241)}$$

$$f = \frac{b / d_a - 1}{1.154 + 0.444 * (b / d_a - 1)} \quad (\text{Equation 11})$$

$$f = \frac{33/8.40 - 1}{1.154 + 0.444 * (33/8.40 - 1)} = 1.19 \text{ (8" PVC SDR 26, ASTM 3034)}$$

$$f = \frac{33/8.625 - 1}{1.154 + 0.444 * (33/8.625 - 1)} = 1.17 \text{ (8" PVC SDR 26, ASTM 2241)}$$

Where:

f = pipe/trench width coefficient

b = trench width (in)

**LANDMARK NORTH - WEST RETAIL – SEWER COLLECTION SYSTEM
ENGINEERING REPORT**

- d_a = pipe diameter (in)
- E_b = modulus of soil reaction for the bedding material (psi)
- E'_n = modulus of soil reaction for the in-situ soil (psi)

Pipe Diameter: 8"(115 psi) Trench Width: 33" Zeta: 1.0
 Pipe Diameter: 8" (160 psi) Trench Width: 33" Zeta: 1.0

Pipe Stiffness

Ps is based on National Reference Standards and manufacturer’s data. Please see Table 7.1 of the “The Uni-Bell Handbook of PVC Pipe: Design and Construction” listing the pipe stiffness of 8" PVC SDR 26, 1160 psi as E = 400,000 psi.

Pipe Diameter: 8" Pipe Material: PVC SDR 26Ps: 115 psi
 Pipe Diameter: 8" Pipe Material: PVC SDR 26Ps: 160 psi

Deflection

Using the Modified Iowa Equation, referenced and published by the Uni-Bell PVC Pipe association and found at <http://www.uni-bell.org/faq.html>, and Equation 14 of Deflection: The Pipe/Soil Mechanism UNI-TR-1-97, Uni-Bell PVC Pipe Association Pgs 17, the predicated pipe deflection can be calculated.

Where

- $\% \Delta Y/D$ = Predicted % vertical deflection under load
- ΔY = Change in vertical pipe diameter under load
- P = Prism Load, psi
- K = Bedding angle constant, Assumed to = 0.096
- W' = Live Load, psi = 0
- DR = Dimension Ration = $\frac{D_o}{t}$ = $\frac{8.40}{0.323}$ = 26(8" PVC, SDR26, ASTM3034)
 = $\frac{8.625}{0.332}$ = 25.98(8" PVC, SDR26, ASTM2241)

Use DR=26

- E = Modulus of tensile elasticity of the pipe material, psi
- E' = Modulus of Soil Reaction (zeta x E_b) = 1000.00
- D_L = Deflection Lag Factor = 1.5

And using the Modified Iowa Equation:

LANDMARK NORTH - WEST RETAIL – SEWER COLLECTION SYSTEM
ENGINEERING REPORT

$$\Delta Y/D(\%) = \frac{(D_s K P + K W) * 100}{[2E/3(DR-1)3] + 0.061E'} \quad (\text{Equation 12})$$

Where Prism Load $P = \frac{\gamma_s * H}{144}$

$$P = \frac{143 * 20}{144} = 19.86 (\text{Equation 3})$$

$$\Delta Y/D(\%) = \frac{[(1.5 * 0.096 * 19.86) + (0)] * 100}{\left[\frac{800000}{46875}\right] + [0.061 * 100000]} = 3.66\%$$

A deflection lag factor of 1.0 is typical for new pipes. Over the life of the pipe, the pipe will tend to deflect. Therefore, 1.5 is a conservation factor for the 50 year life.

	Type of Pipe Material	P _s (psi)	Zeta Factor Assumed or Calculated	E _b (psi)	% Deflection
Pipe Diameter 1	8" PVC SDR 26	115	1.0	1000	3.66%
Pipe Diameter 2	8" PVC SDR 26	160	1.0	1000	3.66%

All pipes proposed for this project have a maximum predicted deflection of less than 5.0%

Safety Considerations

Contractor should follow all safety measure as applicable. There will no sewage from the site until the sewer collection system tested and accepted by San Antonio Water Systems.
Contractor should coordinate with the San Antonio Water Systems construction inspector for tie-in to the existing manhole on time of temporary rerouting of the sewer collection system.

Signature, Seal and Date of the Texas Professional Engineer Below:



Texas Commission on Environmental Quality Organized Sewage Collection System General Construction Notes

Edwards Aquifer Protection Program Construction Notes - Legal Disclaimer

The following listed "construction notes" are intended to be advisory in nature only and do not constitute an approval or conditional approval by the Executive Director...

- 1. This Organized Sewage Collection System (SCS) must be constructed in accordance with 30 Texas Administrative Code (TAC) §213.5(c)...

executive director has reviewed and approved the methods proposed to protect the sensitive feature and the Edwards Aquifer from any potentially adverse impacts to water quality while maintaining the structural integrity of the line.

- 7. Sewer lines located within or crossing the 5-year floodplain of a drainage way will be protected from inundation and stream velocities which could cause erosion and scouring of backfill...

The diameter of the manholes must be a minimum of four feet and the manhole for entry must have a minimum clear opening diameter of 30 inches.

- 10. Where water lines and new sewer line are installed with a separation distance closer than nine feet (i.e., water lines crossing wastewater lines, water lines paralleling wastewater lines, or water lines next to manholes) the installation must meet the requirements of 30 TAC §217.53(d) (Pipe Design) and 30 TAC §290.44(e) (Water Distribution)...

If pipe flexure is proposed, the following method of preventing deflection of the joint must be used: N/A

Specific care must be taken to ensure that the joint is placed in the center of the trench and properly bedded in accordance with 30 TAC §217.54.

- 12. New sewage collection system lines must be constructed with stub outs for the connection of anticipated extensions. The location of such stub outs must be marked on the ground such that their location can be easily determined at the time of connection of the extensions...

If no stub-out is present an alternate method of joining laterals is shown in the detail on Plan Sheet C12.08. (For potential future laterals).

The private service lateral stub-outs must be installed as shown on the plan and profile sheets on Plan Sheet C12.02 - C12.06 and marked after backfilling as shown in the detail on Plan Sheet C12.08.

- 13. Trenching, bedding and backfill must conform with 30 TAC §217.54. The bedding and backfill for flexible pipe must comply with the standards of ASTM D-2321, Classes IA, IB, II or III.

All sewer lines must be tested in accordance with 30 TAC §217.57. The engineer must retain copies of all test results which must be made available to the executive director upon request.

- (a) For a collection system pipe that will transport wastewater by gravity flow, the design must specify an infiltration and exfiltration test or a low-pressure air test. A test must conform to the following requirements: (1) Low Pressure Air Test: (A) A low pressure air test must follow the procedures described in American Society For Testing And Materials (ASTM) C-828, ASTM C-924, or ASTM F-1417...

Equation C.3 T = (0.085 * D * K) / Q

Where:

- T = time for pressure to drop 1.0 pound per square inch gauge in seconds
K = 0.000419 X D X L, but not less than 1.0
D = average inside pipe diameter in inches

- L = length of line of same size being tested, in feet
Q = rate of loss, 0.0015 cubic feet per minute per square foot internal surface
(C) Since a K value of less than 1.0 may not be used, the minimum testing time for each pipe diameter is shown in the following Table C.3:

Table with 4 columns: Pipe Diameter (inches), Minimum Time (seconds), Maximum Length for Minimum Time (feet), Time for Longer Length (seconds/foot)

- (D) An owner may stop a test if no pressure loss has occurred during the first 25% of the calculated testing time.
(E) If any pressure loss or leakage has occurred during the first 25% of a testing period, then the test must continue for the entire test duration as outlined above or until failure.
(F) Wastewater collection system pipes with a 27 inch or larger average inside diameter may be air tested at each joint instead of following the procedure outlined in this section.

the infiltration or exfiltration to an amount within the limits specified. An owner shall retest a pipe following a remediation action.

- (b) If a gravity collection pipe is composed of flexible pipe, deflection testing is also required. The following procedures must be followed: (1) For a collection pipe with inside diameter less than 27 inches, deflection measurement requires a rigid mandrel. (A) Mandrel Sizing: (i) A rigid mandrel must have an outside diameter (OD) not less than 95% of the base inside diameter (ID) or average ID of a pipe...

- 16. All manholes must be tested to meet or exceed the requirements of 30 TAC §217.58. (a) All manholes must pass a leakage test. (b) An owner shall test each manhole (after assembly and backfilling) for leakage, separate and independent of the collection system pipes...

- 17. All private service laterals must be inspected and certified in accordance with 30 TAC §213.5(c)(3)(i). After installation of and, prior to covering and connecting a private service lateral to an existing organized sewage collection system...

Table with 2 columns: Austin Regional Office (12100 Park 35 Circle, Building A, Austin, Texas 78753-1808) and San Antonio Regional Office (14250 Judson Road, San Antonio, Texas 78233-4480)

THESE GENERAL CONSTRUCTION NOTES MUST BE INCLUDED ON THE CONSTRUCTION PLANS PROVIDED TO THE CONTRACTOR AND ALL SUBCONTRACTORS.



PRIMARY CONTACT: RICHARD HENDRIX, P.E.

MACINA • BOSE • COPELAND & ASSOC., INC. CONSULTING ENGINEERS AND LAND SURVEYORS 1035 Central Parkway North, San Antonio, Texas 78232 (210) 545-1122 Fax (210) 545-9502 www.mbcengineers.com FIRM REGISTRATION NUMBER: T.B.P.E. F-784 & T.B.P.L.S. 10011700

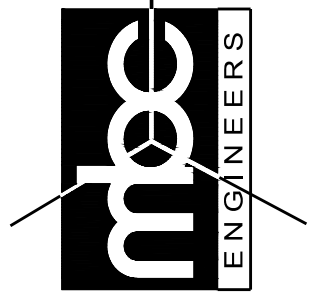

LANDMARK NORTH SITE WORK AND UTILITY IMPROVEMENTS SAN ANTONIO, TEXAS SCS NOTES

Table with columns: REVISIONS (DATE, NO.), DESCRIPTION, BY

Table with columns: PLAT IDW (080586), APPR (RH), DESIGN (GM), DRAWN (DLA), CHECKED (DLA), DATE (03/21/2023), JOB NO. (30371-0976)

S2.00

**Texas Commission on Environmental Quality
 Lift Station and Force Main
 General Construction Notes**

Edwards Aquifer Protection Program Construction Notes – Legal Disclaimer

The following listed "construction notes" are intended to be advisory in nature only and do not constitute an approval or conditional approval by the Executive Director (ED), nor do they constitute a comprehensive listing of rules or conditions to be followed during construction. Further actions may be required to achieve compliance with TCEQ regulations found in Title 30, Texas Administrative Code (TAC), Chapters 213 and 217, as well as local ordinances and regulations providing for the protection of water quality. Additionally, nothing contained in the following listed "construction notes" restricts the powers of the ED, the commission or any other governmental entity to prevent, correct, or curtail activities that result or may result in pollution of the Edwards Aquifer or hydrologically connected surface waters. The holder of any Edwards Aquifer Protection Plan containing "construction notes" is still responsible for compliance with Title 30, TAC, Chapters 213 or any other applicable TCEQ regulation, as well as all conditions of an Edwards Aquifer Protection Plan through all phases of plan implementation. Failure to comply with any condition of the ED's approval, whether or not in contradiction of any "construction notes," is a violation of TCEQ regulations and any violation is subject to administrative rules, orders, and penalties as provided under Title 30, TAC § 213.10 (relating to Enforcement). Such violations may also be subject to civil penalties and injunction. The following listed "construction notes" in no way represent an approved exception by the ED to any part of Title 30 TAC, Chapters 213 and 217, or any other TCEQ applicable regulation

1. This lift station and/or force main must be constructed in accordance with 30 Texas Administrative Code (TAC) §213.5(c), the Texas Commission on Environmental Quality (TCEQ) Edwards Aquifer Rules, and any local government standard specifications.
2. Any modification to the activities described in the referenced Lift Station/Force Main (LSFM) System application following the date of approval may require the submittal of a LSFM System application to modify this approval, including the payment of appropriate fees and all information necessary for its review and approval.
3. A written notice of construction must be submitted to the presiding TCEQ regional office at least 48 hours prior to the start of any regulated activities. This notice must include:
 - the name of the approved project;
 - the activity start date; and
 - the contact information of the prime contractor.
4. Upon completion of any lift station excavation, a geologist must certify that the excavation has been inspected for the presence of sensitive features. The certification must be signed, sealed, and dated by the geologist preparing the certification. Certification that the excavation has been inspected must be submitted to the appropriate regional office.
 - If sensitive feature(s) are identified, all regulated activities near the sensitive feature must be suspended immediately and may not proceed until the executive director has reviewed and approved the methods proposed to protect any sensitive feature and the Edwards Aquifer from potentially adverse impacts to water quality from the lift station.
 - Construction may continue if the geologist certifies that no sensitive feature or features were present.
5. If any sensitive features are discovered during the wastewater line trenching activities, all regulated activities near the sensitive feature must be suspended immediately. The applicant must immediately notify the appropriate regional office of the TCEQ of the feature discovery. A geologist's assessment of the location and extent of the feature discovered must be reported to that regional office in writing within two working days. The applicant must submit a plan for ensuring the structural integrity of the sewer line or for modifying the proposed collection system alignment around the feature. The regulated activities near the sensitive feature may not proceed until the executive director has reviewed and approved the methods proposed to protect the sensitive feature and the Edwards Aquifer from any potentially

- adverse impacts to water quality while maintaining the structural integrity of the line.
6. All force main lines must be tested in accordance with 30 TAC §217.68. Testing method will be:
 - A pressure test must use 50 pounds per square inch above the normal operating pressure of a force main.
 - A temporary valve for pressure testing may be installed near the discharge point of a force main and removed after a test is successfully completed.
 - A pump isolation valve may be used as an opposite termination point.
 - A test must involve filling a force main with water.
 - A pipe must hold the designated test pressure for a minimum of 4.0 hours.
 - The leakage rate must not exceed 10.0 gallons per inch diameter per mile of pipe per day.

Austin Regional Office
 12100 Park 35 Circle, Building A
 Austin, Texas 78753-1808
 Phone (512) 339-2929
 Fax (512) 339-3795

San Antonio Regional Office
 14250 Judson Road
 San Antonio, Texas 78233-4480
 Phone (210) 490-3096
 Fax (210) 545-4329

THESE LIFT STATION AND FORCE MAINS CONSTRUCTION NOTES MUST BE INCLUDED ON THE CONSTRUCTION PLANS PROVIDED TO THE CONTRACTOR AND ALL SUBCONTRACTORS.

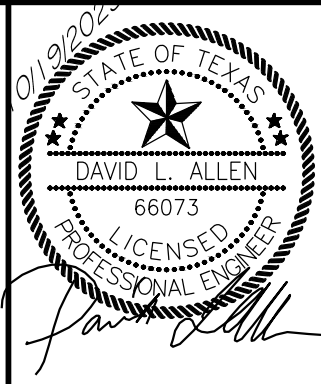

PRIMARY CONTACT:
 RICHARD HENDRIX, P.E.

MACINA • BOSE • COPELAND & ASSOC., INC.
 CONSULTING ENGINEERS AND LAND SURVEYORS
 1035 Central Parkway North, San Antonio, Texas 78232
 (210) 545-1122 Fax (210) 545-9902 www.mbcengineering.com
 FIRM REGISTRATION NUMBER: T.B.P.E. F-784 & T.B.P.L.S. 10011700

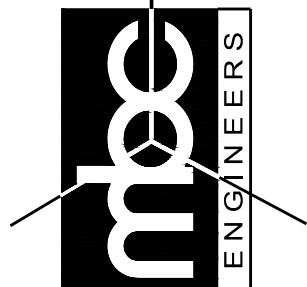

**LANDMARK NORTH
 SITE WORK AND UTILITY IMPROVEMENTS
 SAN ANTONIO, TEXAS
 LIFT STATION NOTES**

REVISIONS:	DATE	NO.	DESCRIPTION	BY

PLAT ID# 080586
 APP# _____
 DESIGN RH
 DRAWN GM
 CHECKED DLA
 DATE 03/21/2023
 JOB NO. 30371-0976

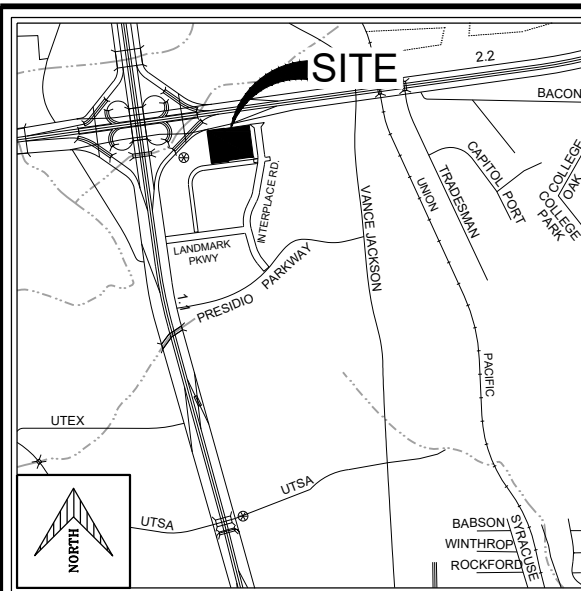

TRENCH EXCAVATION SAFETY PROTECTION
 CONTRACTOR AND/OR CONTRACTORS INDEPENDENTLY RETAINED EMPLOYEE OR STRUCTURAL DESIGN/GEOTECHNICAL/SAFETY EQUIPMENT CONSULTANT, IF ANY, SHALL REVIEW THESE PLANS AND ANY AVAILABLE GEOTECHNICAL INFORMATION AND THE ANTICIPATED INSTALLATION SITES WITHIN THE PROJECT WORK AREA IN ORDER TO IMPLEMENT CONTRACTOR'S TRENCH EXCAVATION SAFETY PROTECTION SYSTEMS, PROGRAMS AND/OR PROCEDURES FOR THE PROJECT DESCRIBED IN THE CONTRACT DOCUMENTS. THE CONTRACTOR'S IMPLEMENTATION OF THESE SYSTEMS, PROGRAMS AND/OR PROCEDURES SHALL PROVIDE FOR ADEQUATE TRENCH EXCAVATION SAFETY PROTECTION THAT COMPLY WITH AS A MINIMUM OSHA STANDARDS FOR TRENCH EXCAVATIONS. SPECIFICALLY, CONTRACTOR AND/OR CONTRACTORS INDEPENDENTLY RETAINED EMPLOYEE OR SAFETY CONSULTANT SHALL IMPLEMENT A TRENCH SAFETY PROGRAM IN ACCORDANCE WITH OSHA STANDARDS GOVERNING THE PRESENCE AND ACTIVITIES OF INDIVIDUALS WORKING IN AND AROUND TRENCH EXCAVATION.

IT IS THE CONTRACTOR'S RESPONSIBILITY TO PROPERLY PLAN AND CONSIDER EXISTING AND PROPOSED DRAINAGE PATTERNS DURING THE CONSTRUCTION OF THE PROJECT. IN ORDER TO ACCOMPLISH THIS, IT MAY BE NECESSARY TO PHASE THE GRADING, CONSTRUCT TEMPORARY BERMS AND SWALES WHILE FACTORING IN SURROUNDING CONDITIONS TO PROPERLY DIRECT AND CONTROL SURFACE RUNOFF. ADDITIONALLY, THE CONTRACTOR SHOULD TAKE INTO ACCOUNT THE TIMING OF CONSTRUCTING PONDS, CHANNELS AND STORM DRAINAGE SYSTEMS.

NOTE: BACKFLOW PREVENTION DEVICES SHALL BE PROVIDED AS DEPICTED OR NOTED ON THE PLANS FOR FIRE LINES, IRRIGATION LINES AND IN SOME CASES DOMESTIC LINES. REFERENCE IRRIGATION PLANS AND THE MEP PLANS FOR ADDITIONAL INFORMATION CONCERNING THESE DEVICES. IN THE EVENT BACKFLOW PREVENTERS ARE NOT CLEARLY SHOWN, CONTRACTOR IS TO CONTACT THE ENGINEER AND REQUEST CLARIFICATION. ON MULTIFAMILY PROJECT BACKFLOW PREVENTION IS REQUIRED WITHIN THE BUILDINGS FOR THE FIRE SYSTEM.

COMPACTION NOTES:
 THE CONTRACTOR SHALL BE RESPONSIBLE FOR MEETING 98% COMPACTION ON ALL TRENCH BACKFILL AND PAYING FOR THE TESTS TO BE PERFORMED BY A THIRD PARTY. COMPACTION TESTS WILL BE DONE AT ONE LOCATION POINT RANDOMLY SELECTED OR AS INDICATED BY THE SAWS INSPECTOR/TEST ADMINISTRATOR PER EACH 12 INCH LOOSE LIFT PER 400 LINEAR FEET AT A MINIMUM PERMITS AND/OR WILL NOT BE ACCEPTED AND FINALIZED BY SAWS WITHOUT THIS REQUIREMENT BEING MET AND VERIFIED BY PROVIDING ALL NECESSARY DOCUMENTED TEST RESULTS.

NOTE: THE CONTRACTOR SHALL INCLUDE IN THE BID THE TRAFFIC AND PEDESTRIAN CONTROL PLANS, DESIGN, AND THE IMPLEMENTATION OF CONTROL DEVICES AS REQUIRED FOR CONSTRUCTION. CONTRACTOR SHALL SEQUENCE CONSTRUCTION SO THAT BUSINESSES HAVE SUITABLE MEANS OF VEHICULAR AND PEDESTRIAN ACCESS.

STREET CUT NOTE
 ALL ASPHALT DAMAGED DURING CONSTRUCTION SHALL BE SAW CUT STRAIGHT AND REPAIRED WITH 3" HMAC TYPE C ASPHALT AND 10" OF ASPHALT TREATED BASE.

NOTE: CONTRACTOR TO LOCATE AND FIELD VERIFY ALL EXISTING UTILITIES INCLUDING, BUT NOT LIMITED TO, WATER LINES, GAS LINES, SEWER LINES AND ELECTRIC LINES.

FEMA 100 YR FLOODPLAIN (EFFECTIVE 09-29-2010)

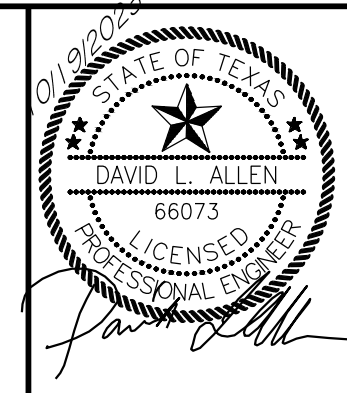
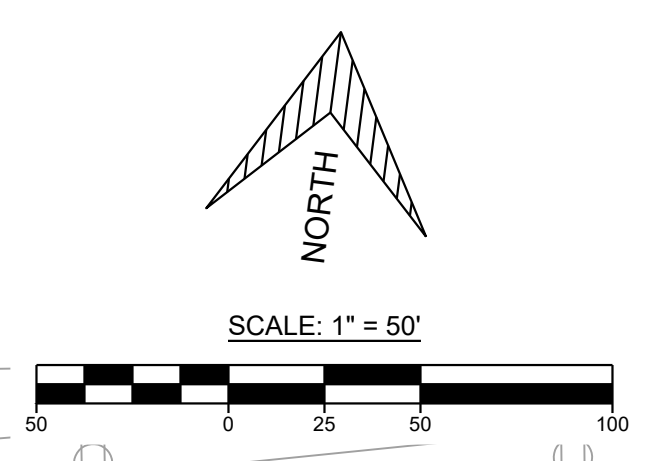
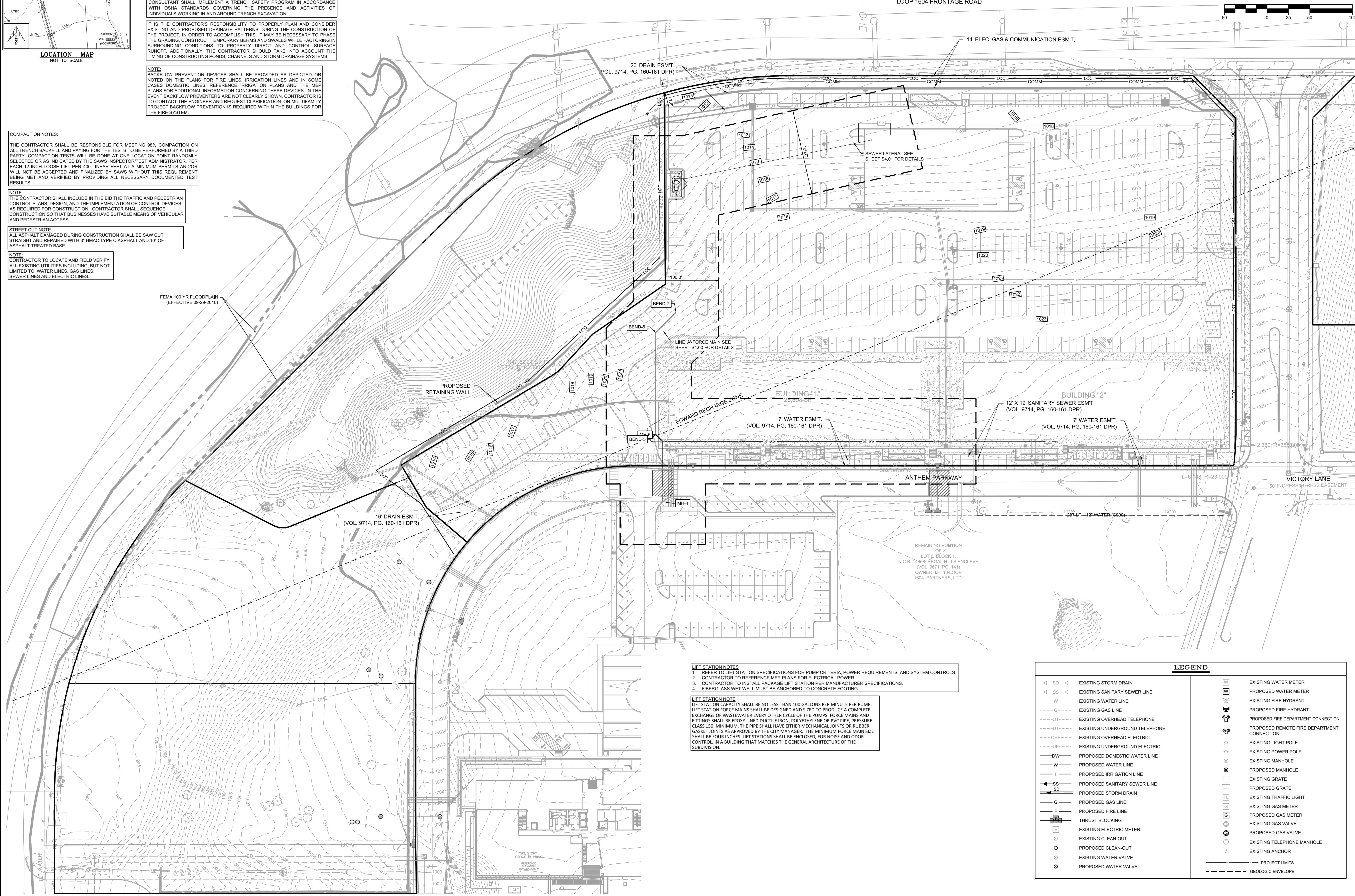

PRIMARY CONTACT:
 RICHARD HENDRIX, P.E.

MACINA • BOSE • COPELAND & ASSOC., INC.
 CONSULTING ENGINEERS AND LAND SURVEYORS
 1035 Central Parkway North, San Antonio, Texas 78232
 (210) 545-1122 Fax (210) 545-9302 www.mbcengineers.com
 FIRM REGISTRATION NUMBER: T.B.P.E. F-784 & T.B.L.S. 10011700

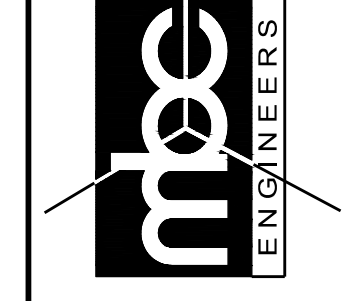

LANDMARK NORTH
 SITE WORK AND UTILITY IMPROVEMENTS
 SAN ANTONIO, TEXAS
 OVERALL SEWER PLAN

Date: 03-19-2023, 10:34am User: D:\mhadak Layout OVERALL SEWER PLAN File: P:\076\0307\Final\mhadak\Design\Site\Overall Sewer\Overall Sewer Plan.dwg Layout name: OVERALL SEWER PLAN

LIFT STATION NOTES
 1. REFER TO LIFT STATION SPECIFICATIONS FOR PUMP CRITERIA, POWER REQUIREMENTS, AND SYSTEM CONTROLS.
 2. CONTRACTOR TO REFERENCE MEP PLANS FOR ELECTRICAL POWER.
 3. CONTRACTOR TO INSTALL PACKAGE LIFT STATION PER MANUFACTURER SPECIFICATIONS.
 4. FIBERGLASS WET WELL MUST BE ANCHORED TO CONCRETE FOOTING.

LIFT STATION NOTE
 LIFT STATION CAPACITY SHALL BE NO LESS THAN 100 GALLONS PER MINUTE PER PUMP. LIFT STATION FORCE MAINS SHALL BE DESIGNED AND SIZED TO PRODUCE A COMPLETE EXCHANGE OF WASTEWATER EVERY OTHER CYCLE OF THE PUMPS. FORCE MAINS AND FITTINGS SHALL BE EPDM LINED DUCTILE IRON, POLYETHYLENE OR PVC PIPE, PRESSURE CLASS 150, MINIMUM. THE PIPE SHALL HAVE EITHER MECHANICAL JOINTS OR RUBBER GASKET JOINTS AS APPROVED BY THE CITY MANAGER. THE MINIMUM FORCE MAIN SIZE SHALL BE FOUR INCHES. LIFT STATIONS SHALL BE ENCLOSED FOR NOISE AND ODOR CONTROL, IN A BUILDING THAT MATCHES THE GENERAL ARCHITECTURE OF THE SUBDIVISION.

LEGEND			
—SD—	EXISTING STORM DRAIN	⊞	EXISTING WATER METER
—SS—	EXISTING SANITARY SEWER LINE	⊞	PROPOSED WATER METER
—W—	EXISTING WATER LINE	⊞	EXISTING FIRE HYDRANT
—G—	EXISTING GAS LINE	⊞	PROPOSED FIRE HYDRANT
—OT—	EXISTING OVERHEAD TELEPHONE	⊞	PROPOSED FIRE DEPARTMENT CONNECTION
—UT—	EXISTING UNDERGROUND TELEPHONE	⊞	PROPOSED REMOTE FIRE DEPARTMENT CONNECTION
—OHE—	EXISTING OVERHEAD ELECTRIC	⊞	EXISTING LIGHT POLE
—UE—	EXISTING UNDERGROUND ELECTRIC	⊞	EXISTING POWER POLE
—DW—	PROPOSED DOMESTIC WATER LINE	⊞	EXISTING MANHOLE
—W—	PROPOSED WATER LINE	⊞	PROPOSED MANHOLE
—I—	PROPOSED IRRIGATION LINE	⊞	EXISTING GRATE
—SS—	PROPOSED SANITARY SEWER LINE	⊞	PROPOSED GRATE
—SD—	PROPOSED STORM DRAIN	⊞	EXISTING TRAFFIC LIGHT
—G—	PROPOSED GAS LINE	⊞	EXISTING GAS METER
—F—	PROPOSED FIRE LINE	⊞	PROPOSED GAS METER
—TB—	THRUST BLOCKING	⊞	EXISTING GAS VALVE
⊞	EXISTING ELECTRIC METER	⊞	PROPOSED GAS VALVE
⊞	EXISTING CLEAN-OUT	⊞	EXISTING TELEPHONE MANHOLE
⊞	PROPOSED CLEAN-OUT	⊞	EXISTING ANCHOR
⊞	EXISTING WATER VALVE	⊞	PROJECT LIMITS
⊞	PROPOSED WATER VALVE	⊞	GEOLOGIC ENVELOPE

REVISIONS:	DATE	DESCRIPTION

PLAT DW: 080586
 APPR: RH
 DESIGN: GM
 DRAWN: DLA
 CHECKED: DLA
 DATE: 03/21/2023
 JOB NO.: 30371-0976

\$3.00

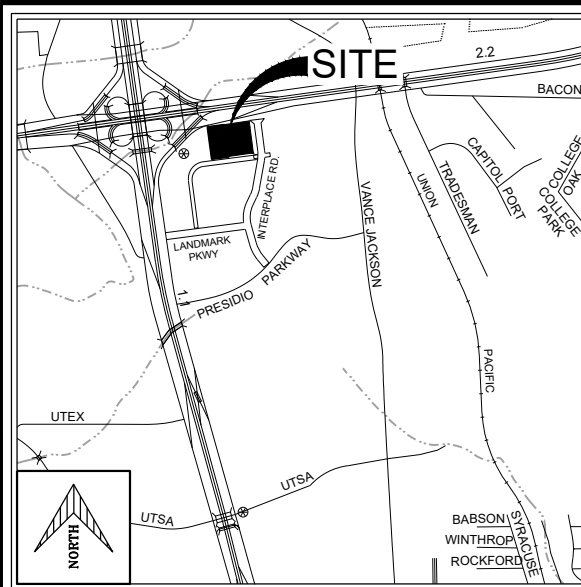

NOTE:
REFERENCE GENERAL NOTES ON SHEET C02.00
PRIOR TO BID AND CONSTRUCTION

- NOTES:
1. ALL GRAVITY SANITARY SEWER LINES SHALL CONFORM TO ASTM D 3034, PVC SDR 26 WITH ASTM 5212 JOINTS. GRAVITY SANITARY SEWER LINES CROSSING POTABLE WATER LINES SHALL CONFORM TO 30TAC217.53(d).
 2. CONTRACTOR TO VERIFY ALL WASTEWATER LINE GRADE AND ALIGNMENTS AT NO GREATER THAN 50' INTERVALS.
 3. PIPE STATIONING AND LINEAR FOOTAGE IS FROM CENTER OF MANHOLE TO CENTER OF MANHOLE. PIPE SLOPE IS CALCULATED FROM INSIDE FACE OF MANHOLE TO INSIDE FACE OF MANHOLE.
 4. ALL PUBLIC AND PRIVATE WASTEWATER SERVICE LINES TO BE SDR 26 PVC.
 5. ALL FORCE MAIN LINES TO BE SDR 21 PVC.
 6. CONTRACTOR TO INSTALL AIR RELEASE VALVES AT HIGH POINTS ON FORCE MAIN.
 7. ALL FORCE MAIN BENDS SHALL BE SWEEPING BENDS.

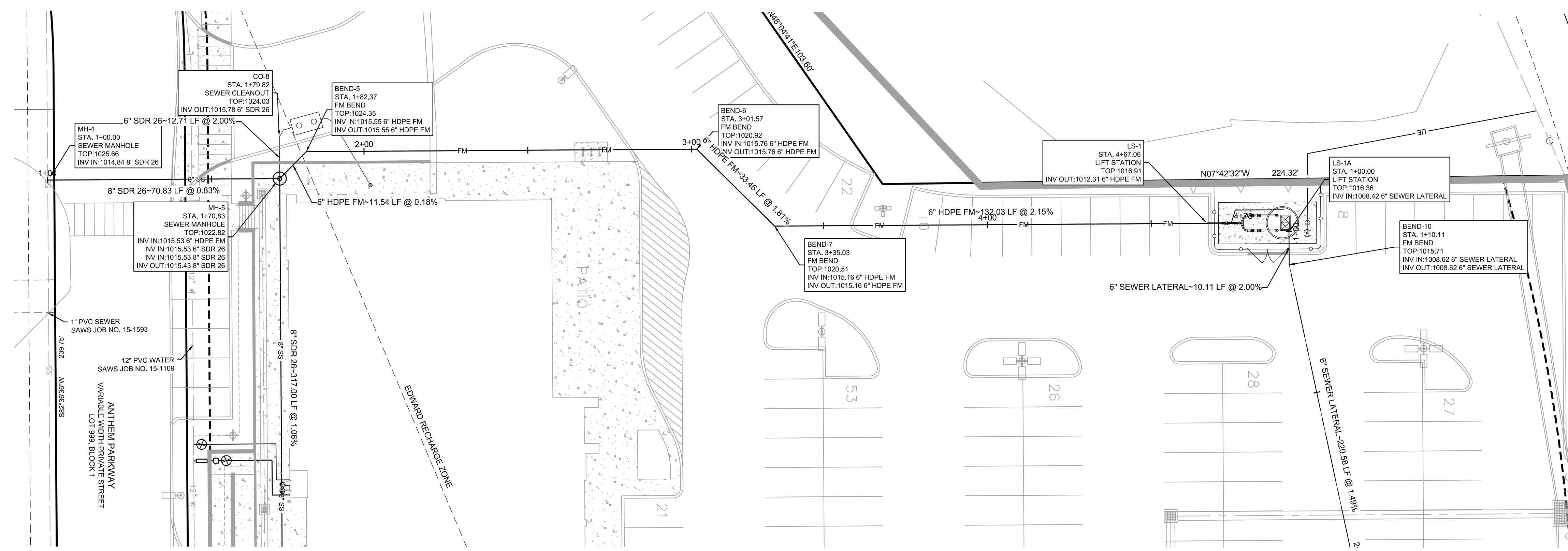
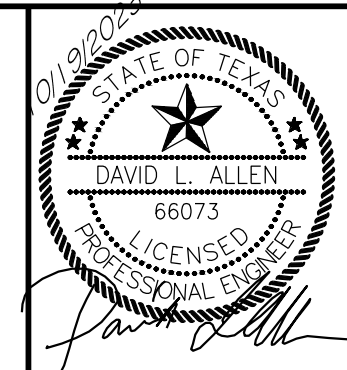
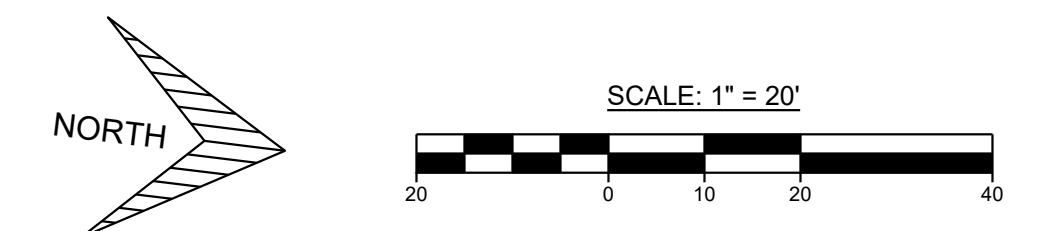

SCALE:
HORIZONTAL 1"=20'
VERTICAL 1"=5'

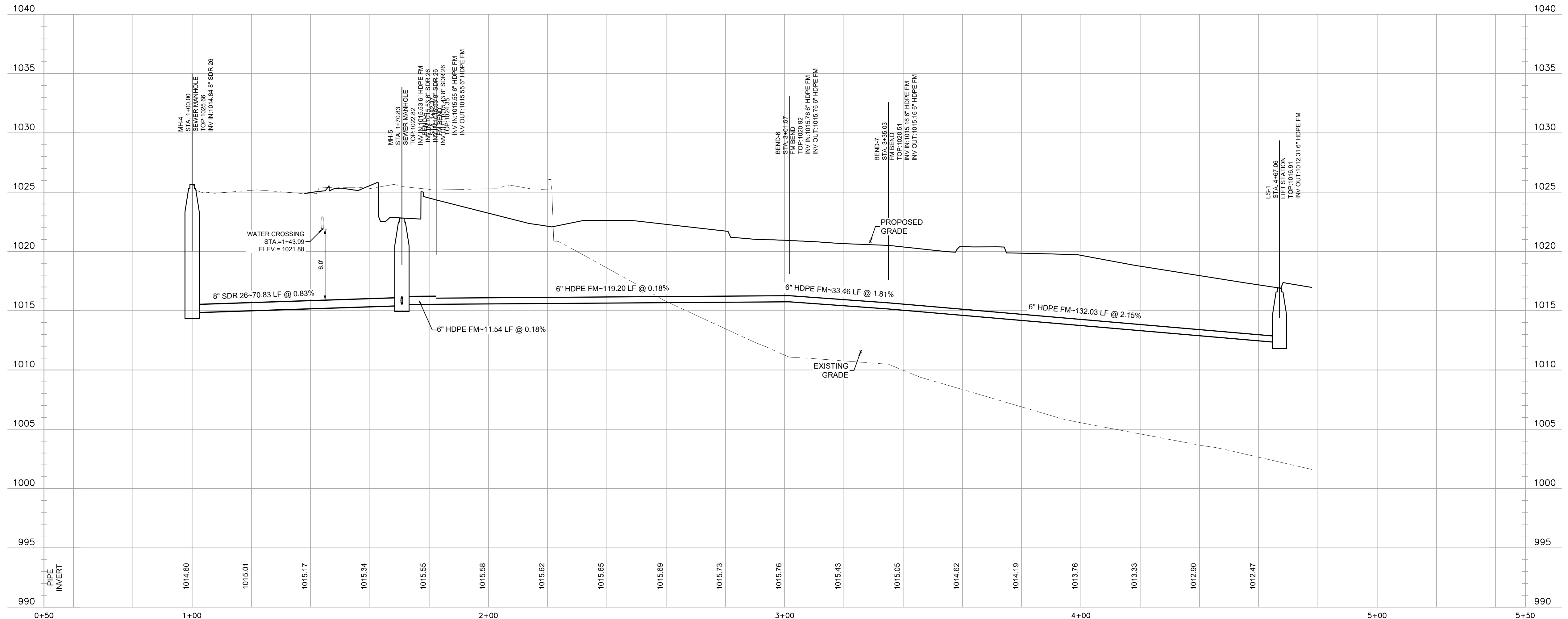

Date: 03/19/2023, 10:34am User: D:\hondax Layout\LINE 'A'-FORCE MAIN P&P File: P:\076\30371\Fulcrum\landmark\Design\trac\Design\Drawn\North-West\Tmads\SCS - sewerhigh-sewer-plan and profile-30371.dwg Layout name: LINE 'A'-FORCE MAIN P&P

PRIMARY CONTACT:
RICHARD HENDRIX, P.E.

MACINA • BOSE • COPELAND & ASSOC., INC.
CONSULTING ENGINEERS AND LAND SURVEYORS
1035 Central Parkway North, San Antonio, Texas 78232
(210) 545-1122 Fax (210) 545-9302 www.mbcengineers.com
FIRM REGISTRATION NUMBER: T.B.P.E. F-784 & T.B.P.L.S. 10011700

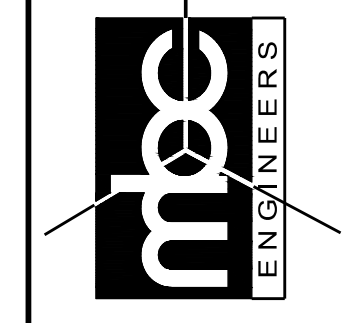

LANDMARK NORTH
SITE WORK AND UTILITY IMPROVEMENTS
SAN ANTONIO, TEXAS
LINE 'A'-FORCE MAIN P&P

REVISIONS:	DATE	DESCRIPTION	BY

PLAT ID# 080586
APP# RH
DESIGN# GM
DRAWN# DLA
CHECKED# DLA
DATE 03/21/2023
JOB NO. 30371-0976

S4.00

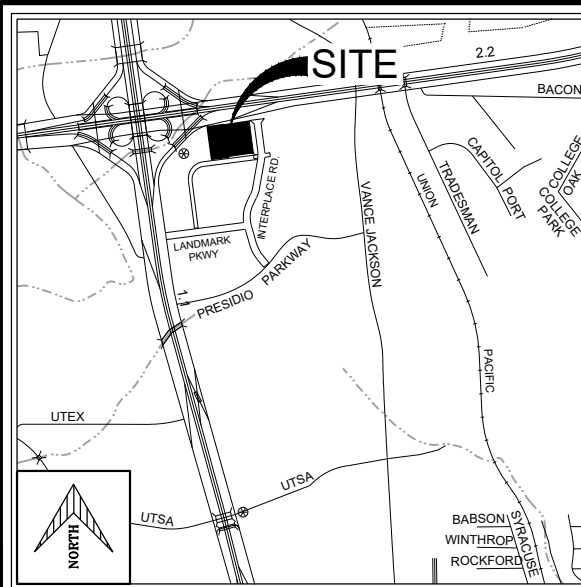

NOTE:
REFERENCE GENERAL NOTES ON SHEET C02.00
PRIOR TO BID AND CONSTRUCTION

- NOTES:
1. ALL GRAVITY SANITARY SEWER LINES SHALL CONFORM TO ASTM D 3034, PVC SDR 26 WITH ASTM 5212 JOINTS. GRAVITY SANITARY SEWER LINES CROSSING POTABLE WATER LINES SHALL CONFORM TO 30TAC217.53(d).
 2. CONTRACTOR TO VERIFY ALL WASTEWATER LINE GRADE AND ALIGNMENTS AT NO GREATER THAN 50' INTERVALS.
 3. PIPE STATIONING AND LINEAR FOOTAGE IS FROM CENTER OF MANHOLE TO CENTER OF MANHOLE. PIPE SLOPE IS CALCULATED FROM INSIDE FACE OF MANHOLE TO INSIDE FACE OF MANHOLE.
 4. ALL PUBLIC AND PRIVATE WASTEWATER SERVICE LINES TO BE SDR 26 PVC.
 5. ALL FORCE MAIN LINES TO BE SDR 21 PVC.
 6. CONTRACTOR TO INSTALL AIR RELEASE VALVES AT HIGH POINTS ON FORCE MAIN.
 7. ALL FORCE MAIN BENDS SHALL BE SWEEPING BENDS.

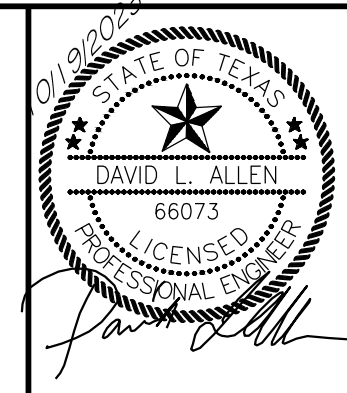
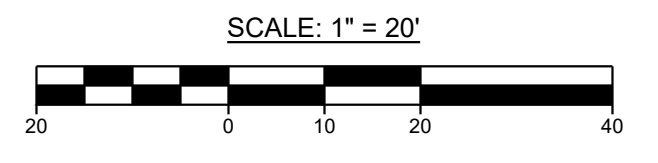
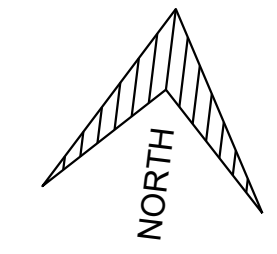

PRIMARY CONTACT:
RICHARD HENDRIX, P.E.

MACINA • BOSE • COPELAND & ASSOC., INC.
CONSULTING ENGINEERS AND LAND SURVEYORS
1035 Central Parkway North, San Antonio, Texas 78232
(210) 545-1122 Fax (210) 545-9302 www.mbcengineering.com
FIRM REGISTRATION NUMBER: T.B.P.E. F-784 & T.B.P.L.S. 10011700

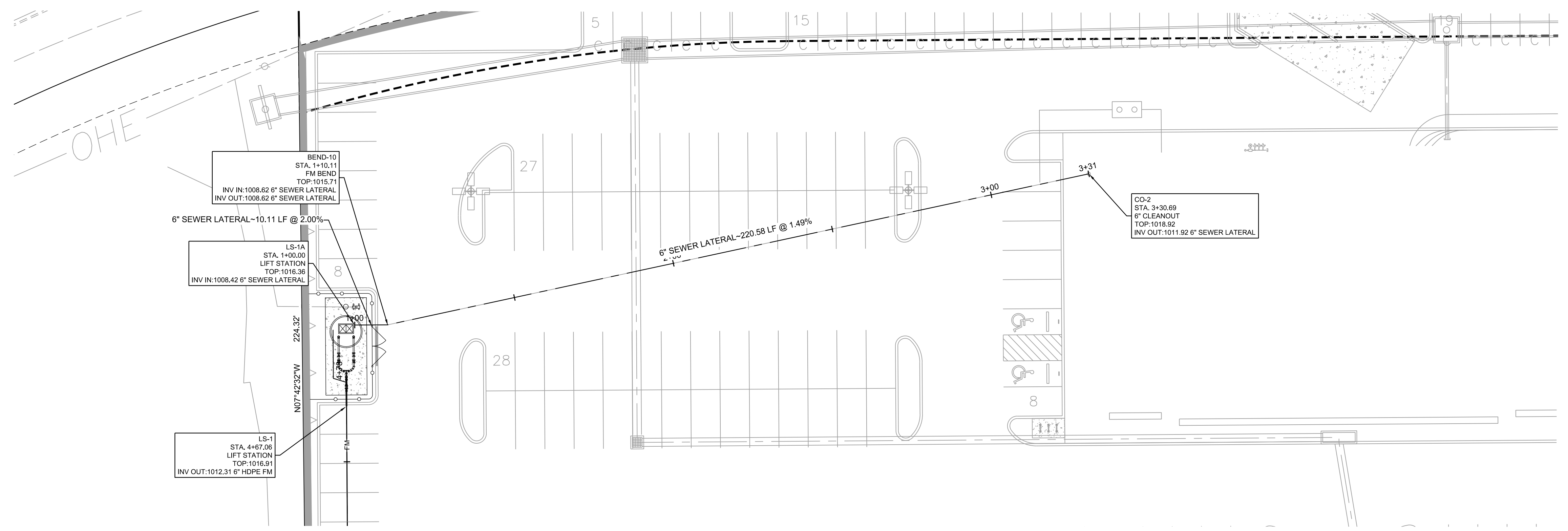
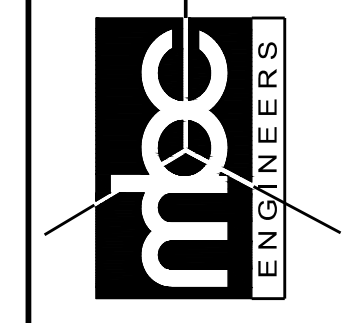

SCALE:
HORIZONTAL 1"=20'
VERTICAL 1"=5'

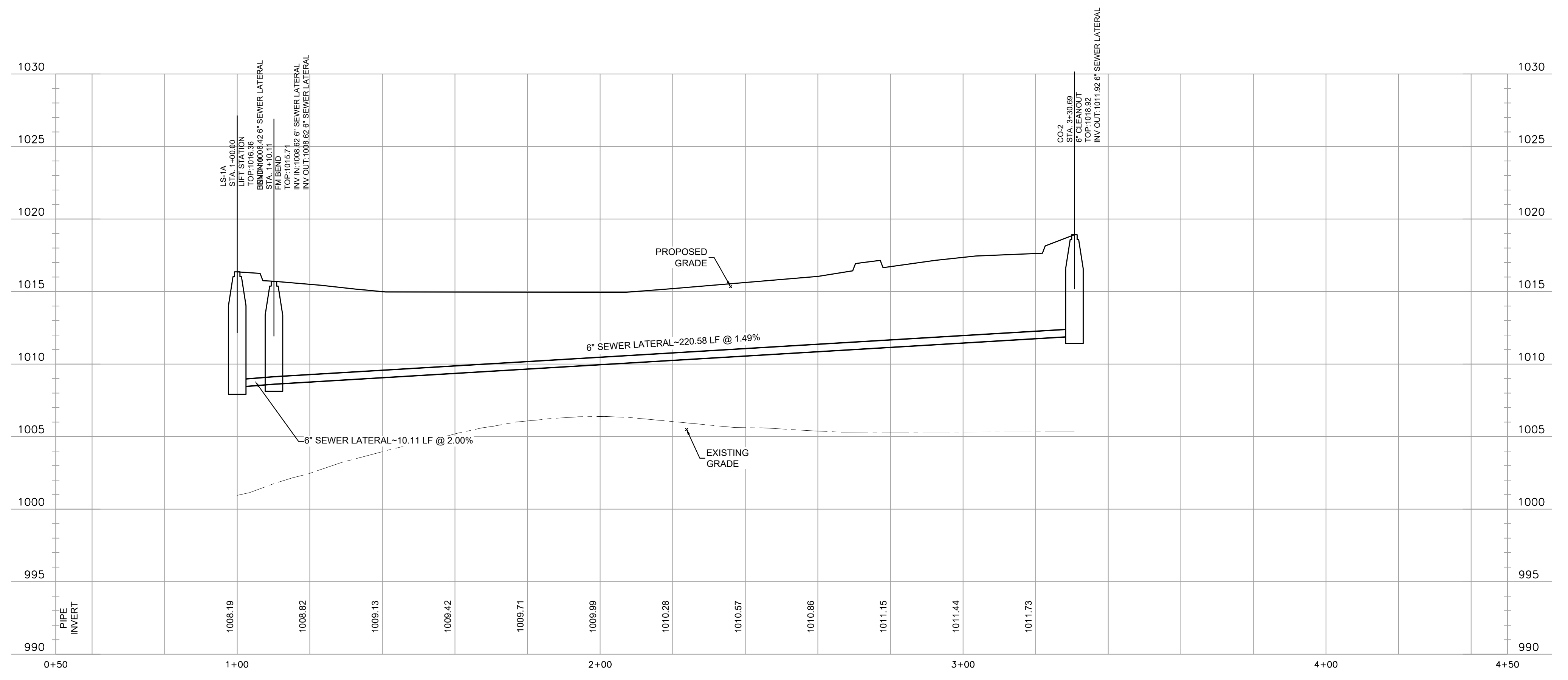

Date: 08-19-2023, 10:35am User: D:\hmdxk Layout: SEWER LATERAL P&P File: P:\076\30371-Fulcrum\landmark\Design\trac\Design\Drawn\North-West\TmdxSCS - sewerhigh-sewer-plan and profile-30371.dwg Layout name: SEWER LATERAL P&P

LANDMARK NORTH
SITE WORK AND UTILITY IMPROVEMENTS
SAN ANTONIO, TEXAS
SEWER LATERAL P&P

REVISIONS:	DATE	DESCRIPTION	BY

PLAT ID# 080586
APP: _____
DESIGN: RH
DRAWN: GM
CHECKED: DLA
DATE: 03/21/2023
JOB NO: 30371-0976

S4.01

NOTE:
REFERENCE GENERAL NOTES ON SHEET C02.00
PRIOR TO BID AND CONSTRUCTION

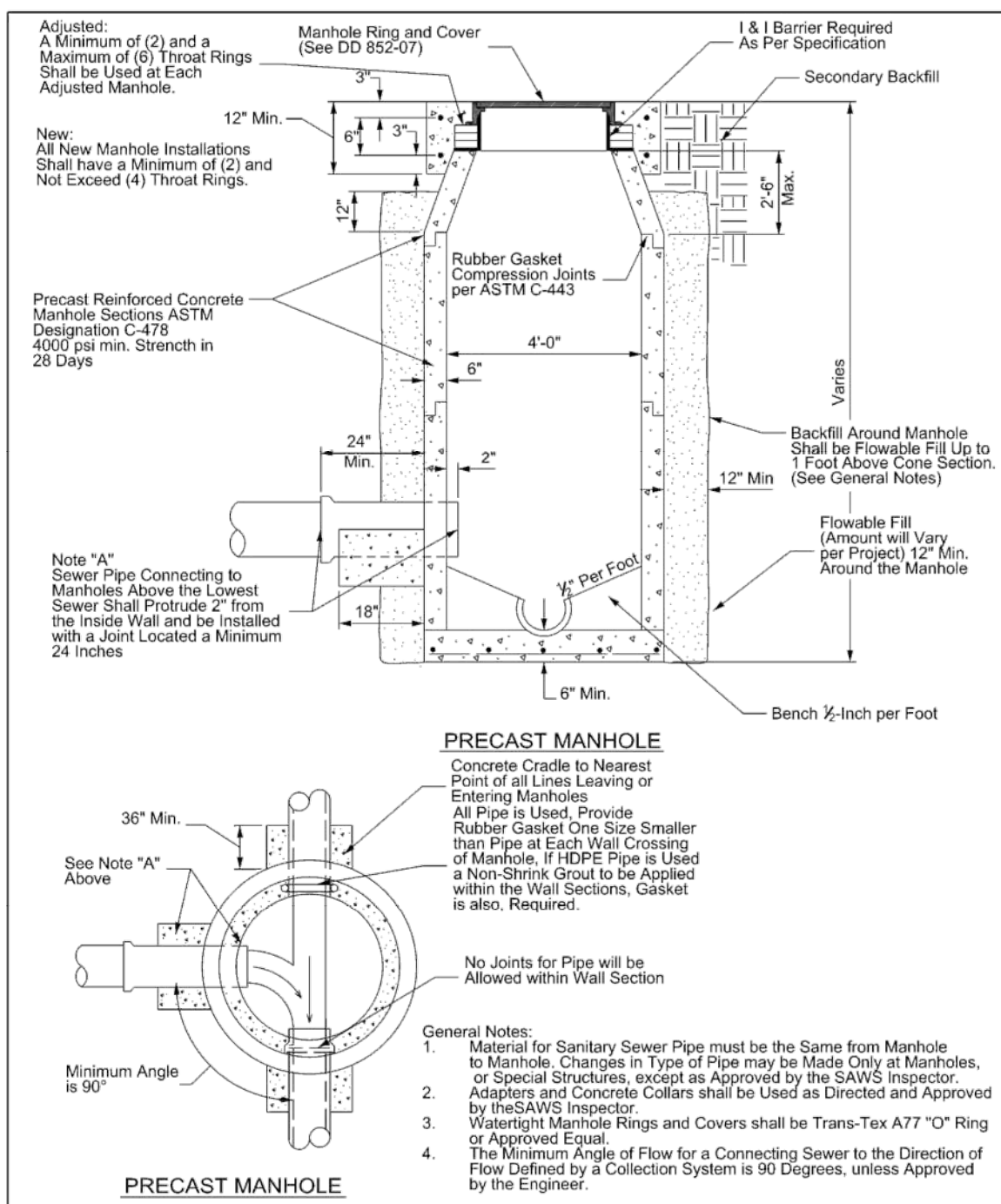

PROPERTY OF SAN ANTONIO WATER SYSTEM SAN ANTONIO, TEXAS	STANDARD PRECAST MANHOLE	APPROVED MAY 2013	REVISED AUG 2019
		DD-852-01	
		SHEET 1 OF 2	

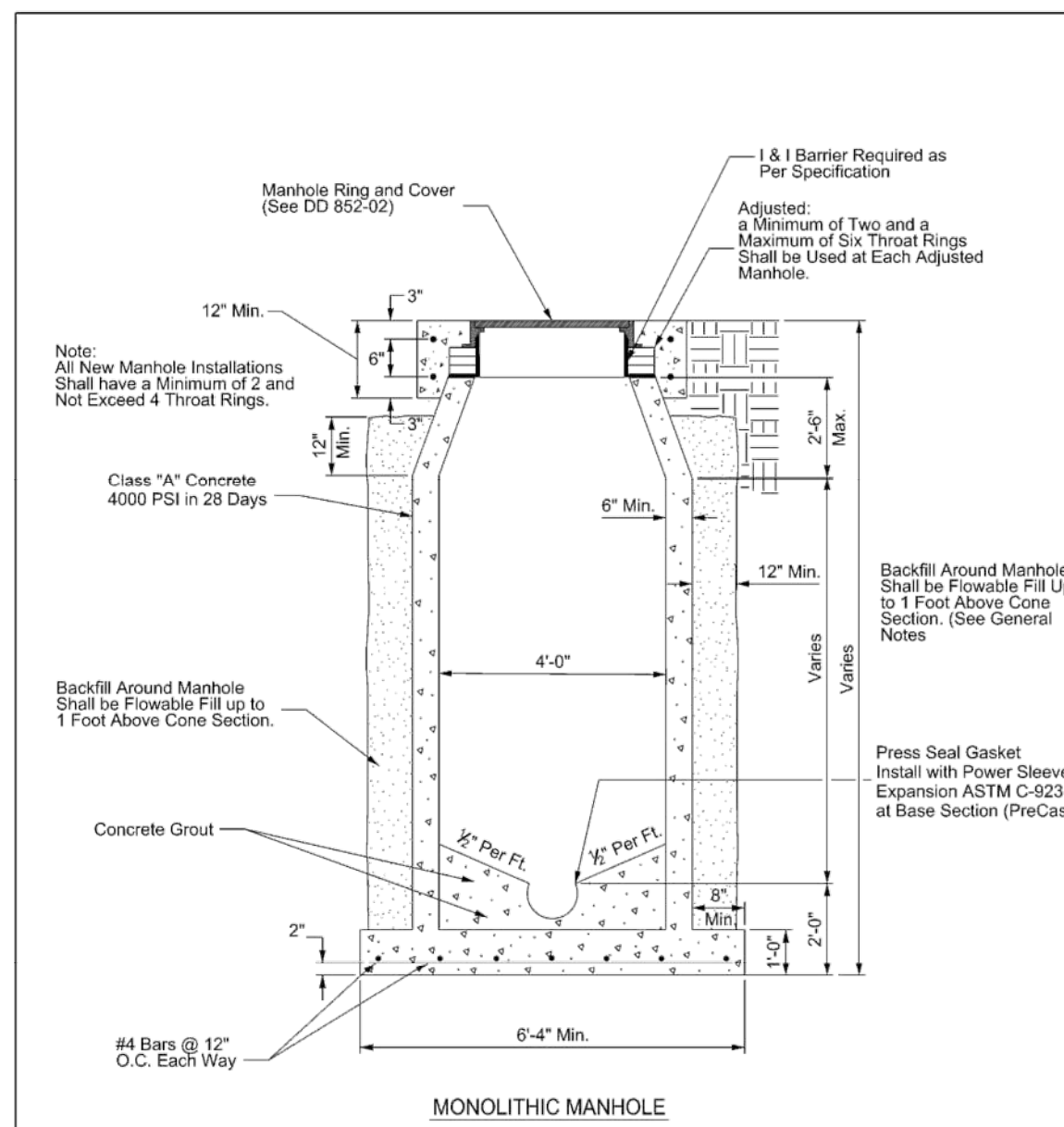

PROPERTY OF SAN ANTONIO WATER SYSTEM SAN ANTONIO, TEXAS	STANDARD MONOLITHIC MANHOLE	APPROVED MARCH 2008	REVISED AUG 2019
		DD 852-01	
		SHEET 2 OF 2	

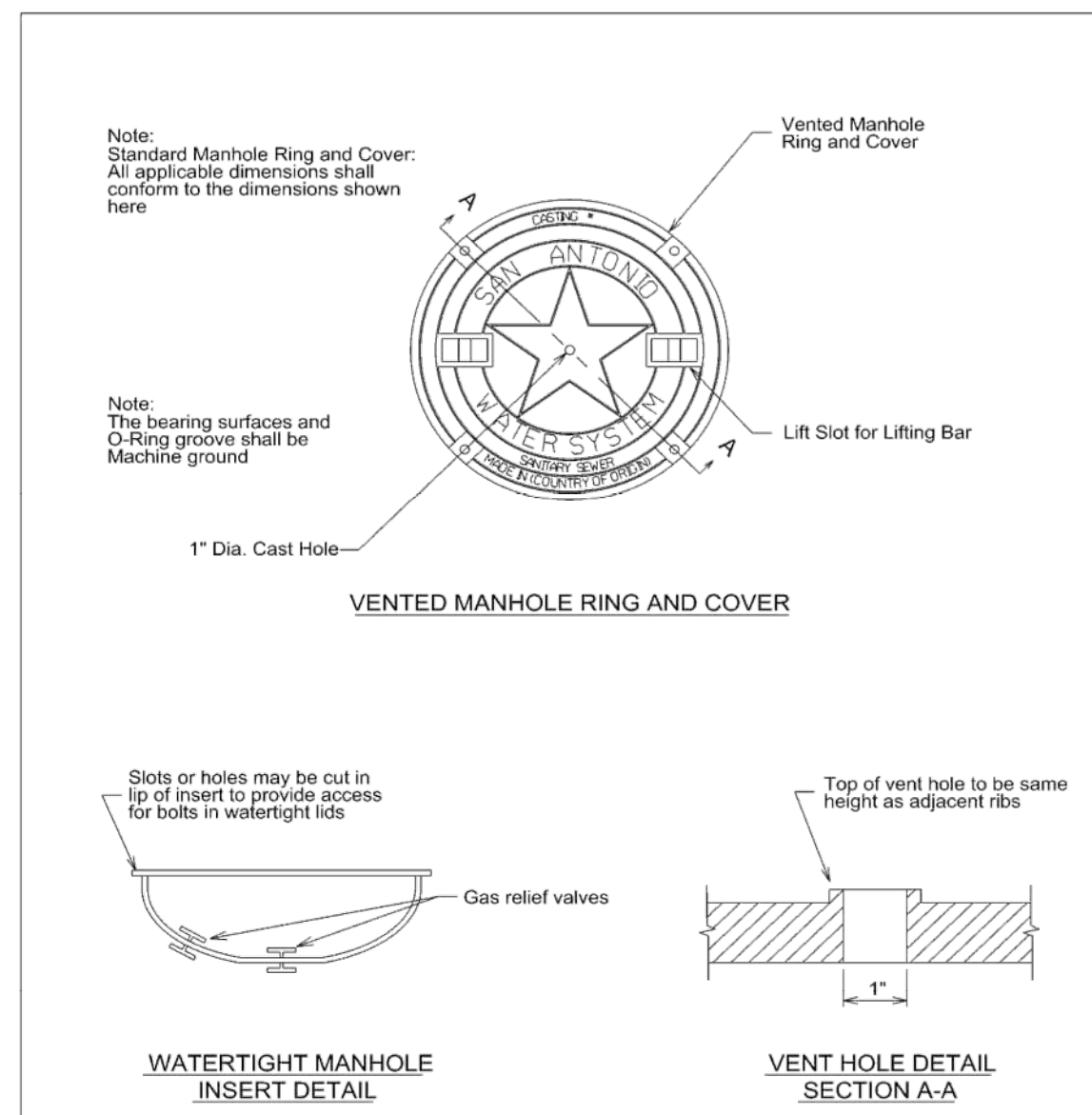

PROPERTY OF SAN ANTONIO WATER SYSTEM SAN ANTONIO, TEXAS	VENTED MANHOLE RING AND COVER DETAIL	APPROVED JANUARY 2005	REVISED AUG 2019
		DD-852-02	
		SHEET 1 OF 1	

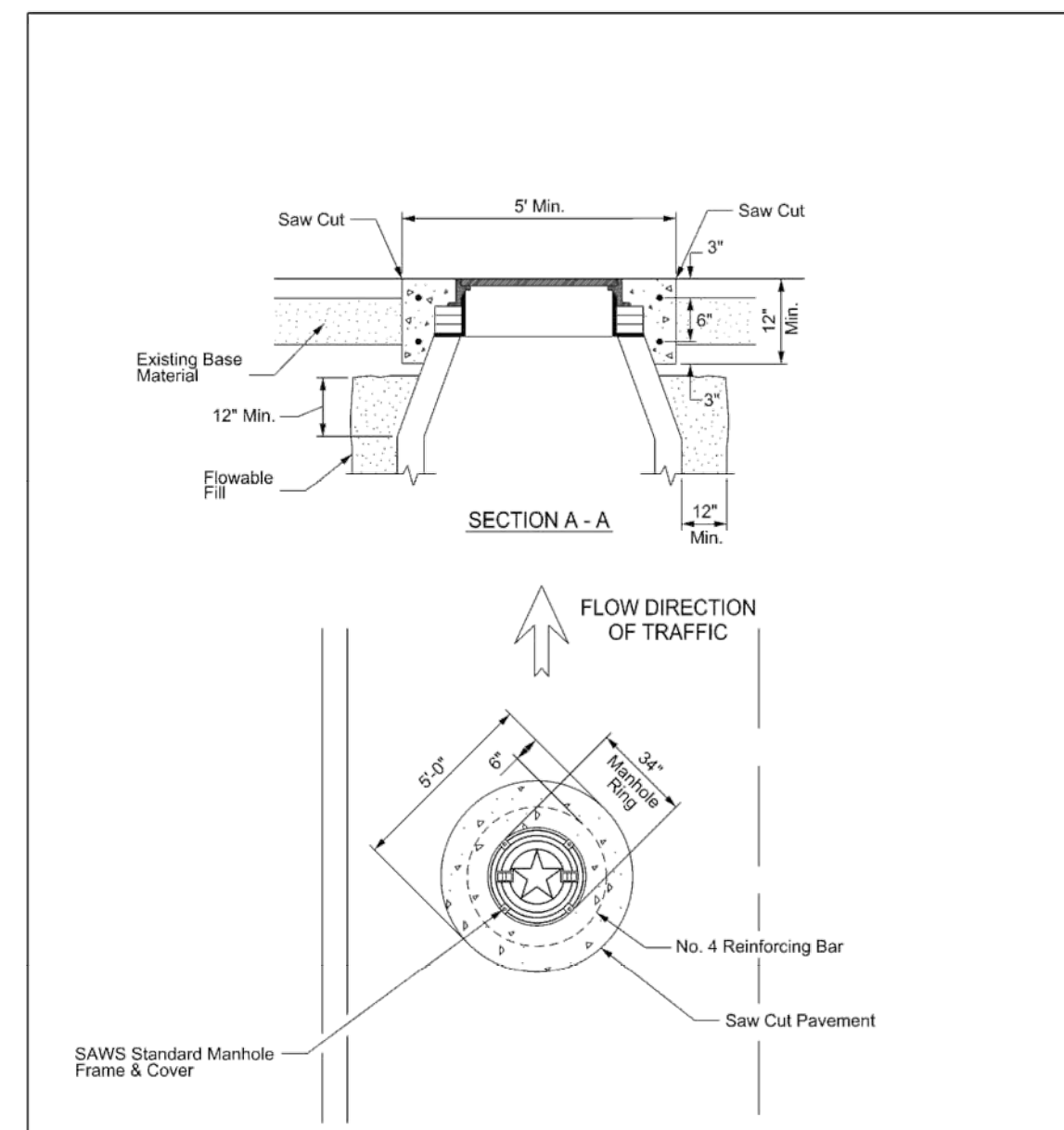

PROPERTY OF SAN ANTONIO WATER SYSTEM SAN ANTONIO, TEXAS	MANHOLE RING ENCASEMENT DETAIL	APPROVED AUGUST 2009	REVISED AUG 2019
		DD 852-03	
		SHEET 1 OF 2	

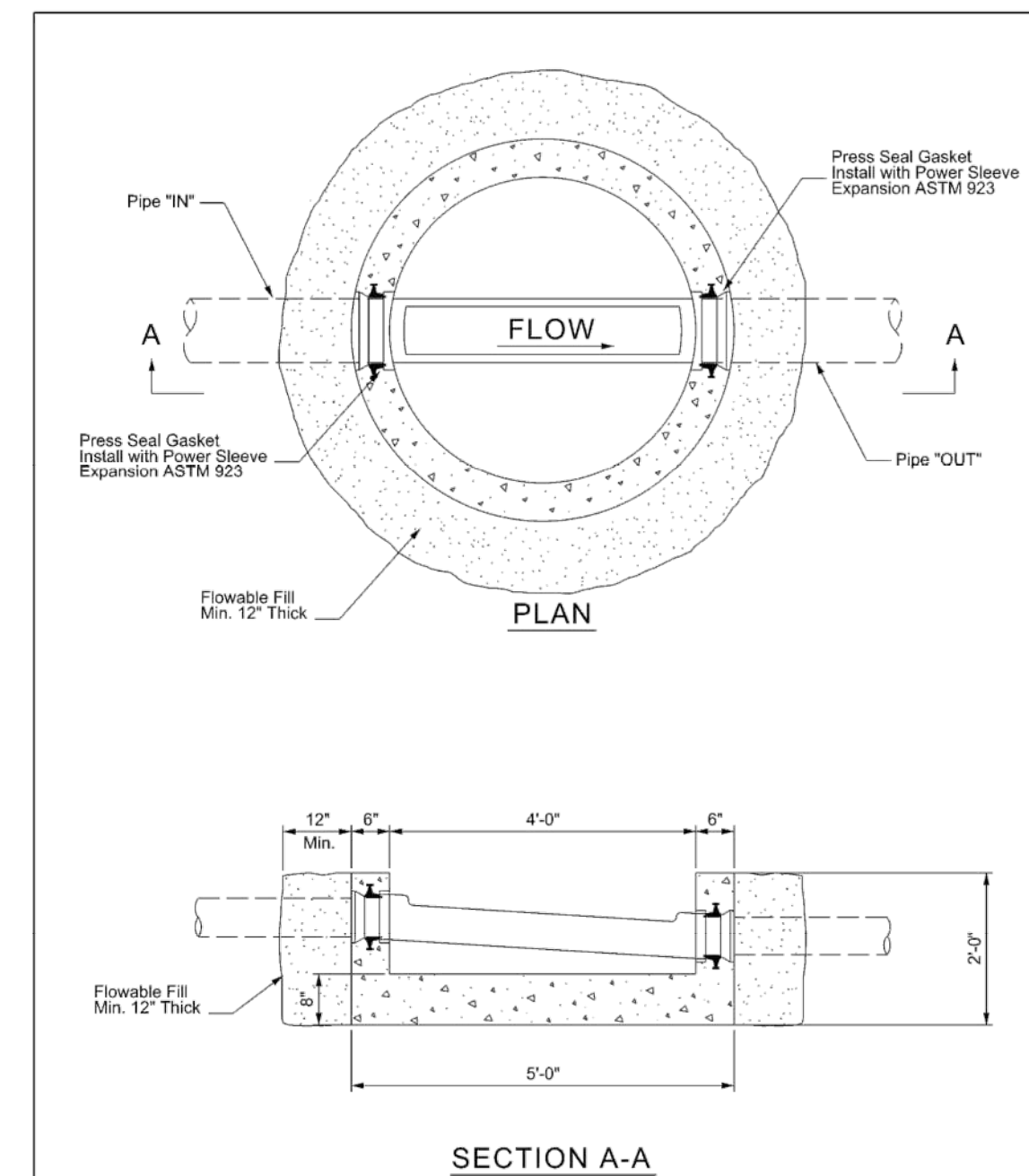

PROPERTY OF SAN ANTONIO WATER SYSTEM SAN ANTONIO, TEXAS	PRECAST MANHOLE BASE STRAIGHT THROUGH	APPROVED MARCH 2008	REVISED AUG 2019
		DD-852-05	
		SHEET 1 OF 1	

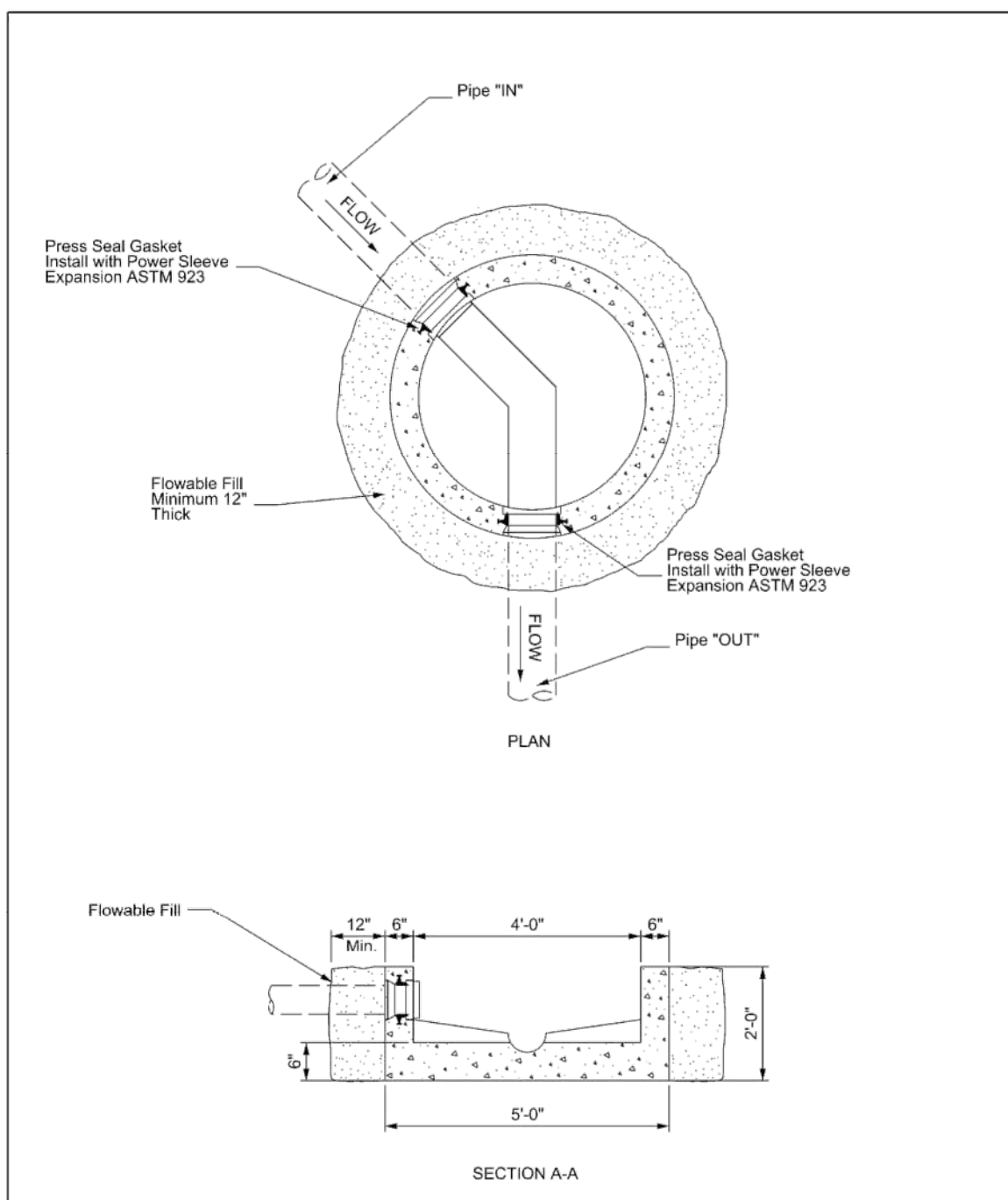

PROPERTY OF SAN ANTONIO WATER SYSTEM SAN ANTONIO, TEXAS	PRECAST MANHOLE BASE 45° ANGLE	APPROVED MARCH 2008	REVISED AUG 2019
		DD-852-06	
		SHEET 1 OF 1	

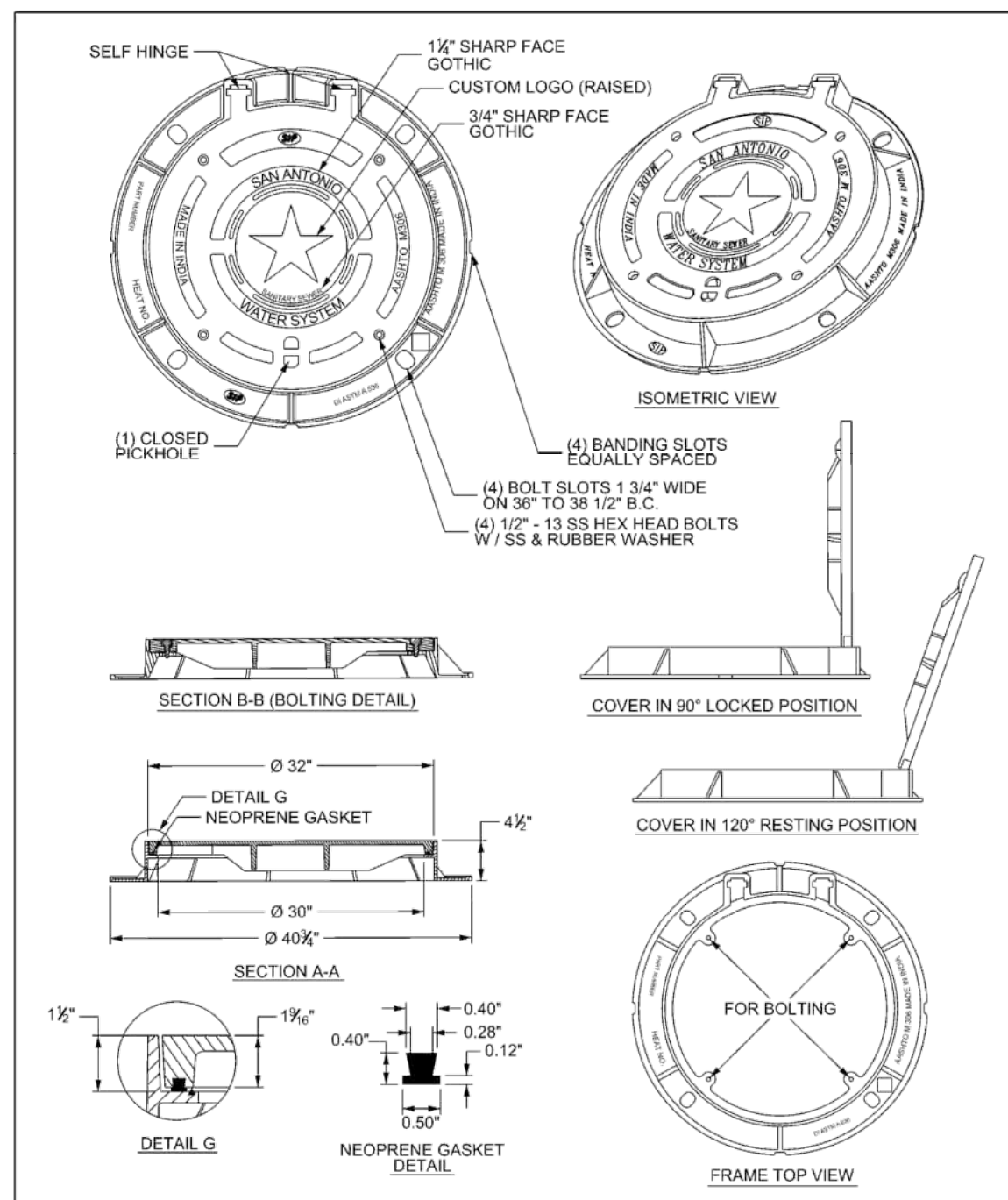

PROPERTY OF SAN ANTONIO WATER SYSTEM SAN ANTONIO, TEXAS	30" MANHOLE RING AND COVER DETAIL	APPROVED MARCH 2008	REVISED AUG 2019
		DD 852-07	
		SHEET 1 OF 5	

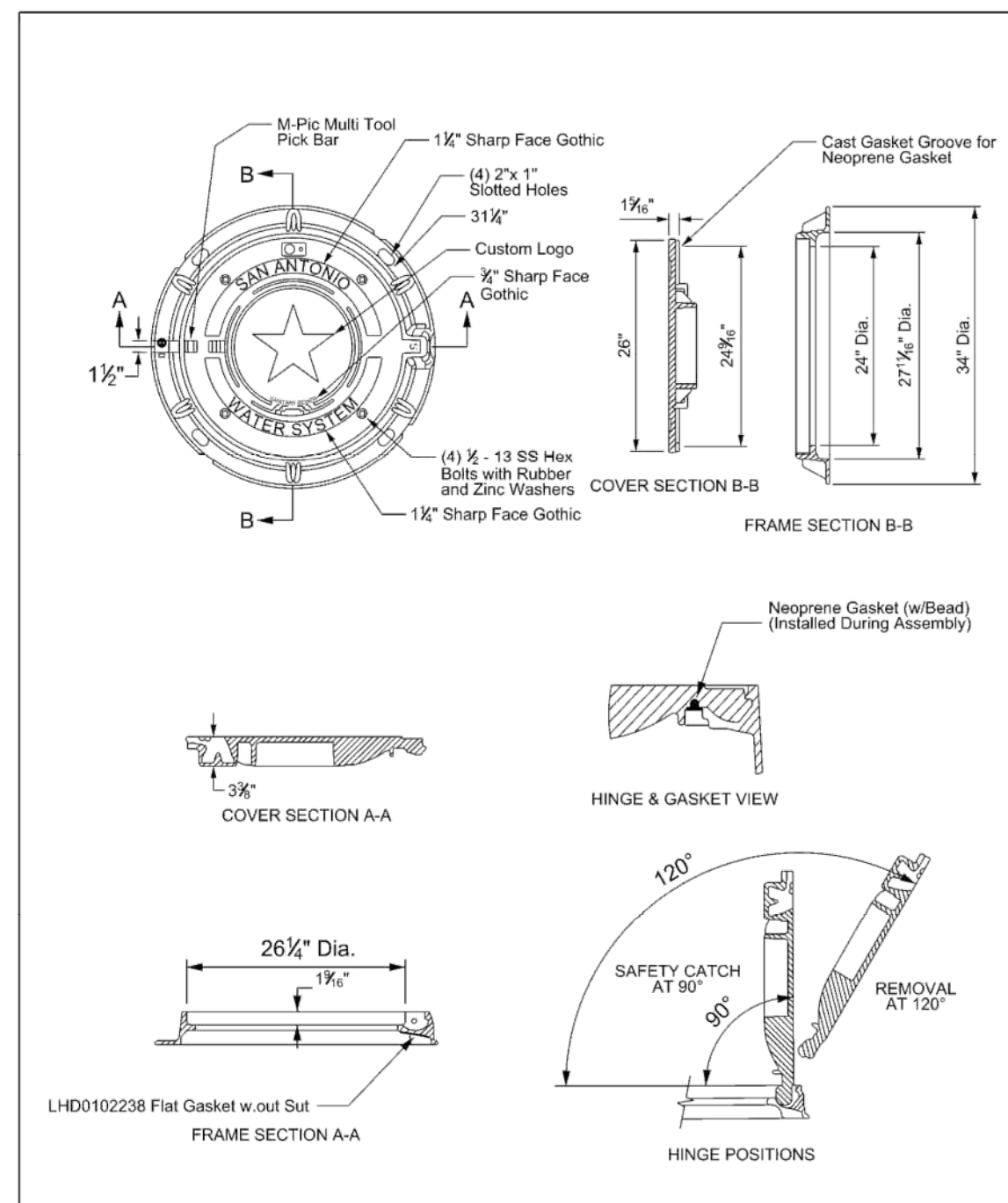

PROPERTY OF SAN ANTONIO WATER SYSTEM SAN ANTONIO, TEXAS	MANHOLE RING AND COVER DETAIL	APPROVED MARCH 2008	REVISED AUG 2019
		DD 852-07	
		SHEET 2 OF 5	

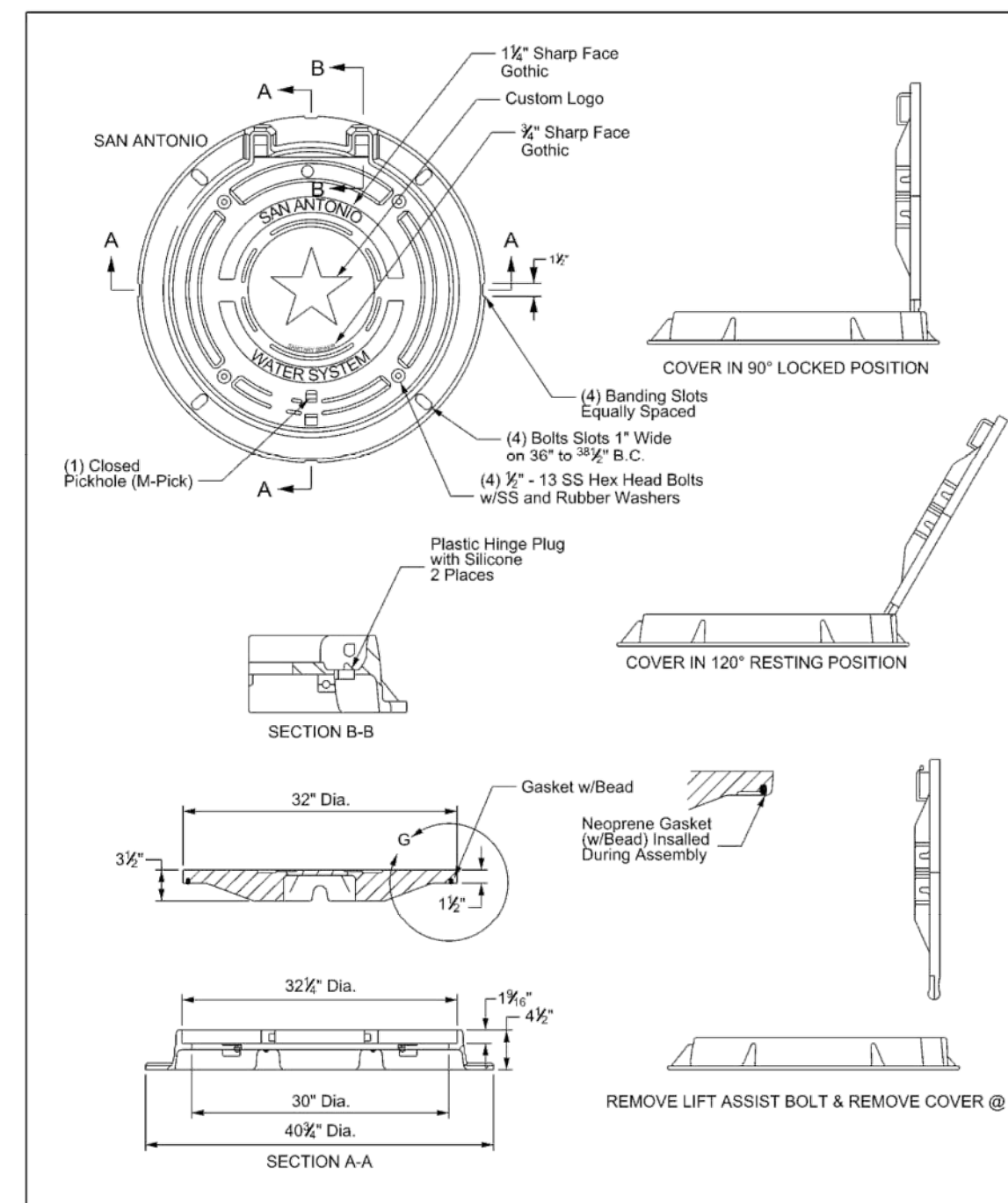

PROPERTY OF SAN ANTONIO WATER SYSTEM SAN ANTONIO, TEXAS	MANHOLE RING AND COVER DETAIL	APPROVED MARCH 2008	REVISED AUG 2019
		DD 852-07	
		SHEET 3 OF 5	

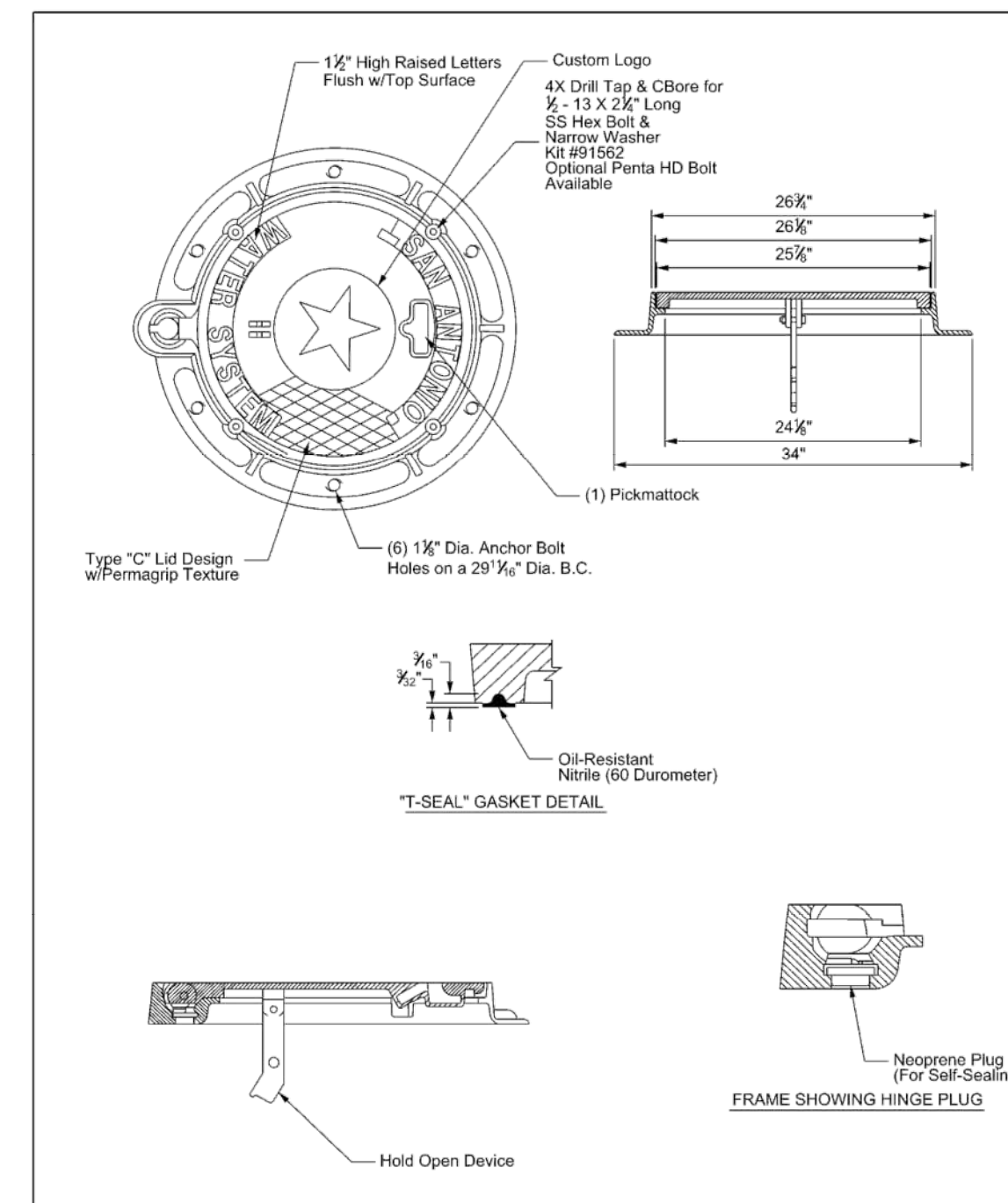

PROPERTY OF SAN ANTONIO WATER SYSTEM SAN ANTONIO, TEXAS	MANHOLE RING AND COVER DETAIL	APPROVED MARCH 2008	REVISED AUG 2019
		DD 852-07	
		SHEET 4 OF 5	

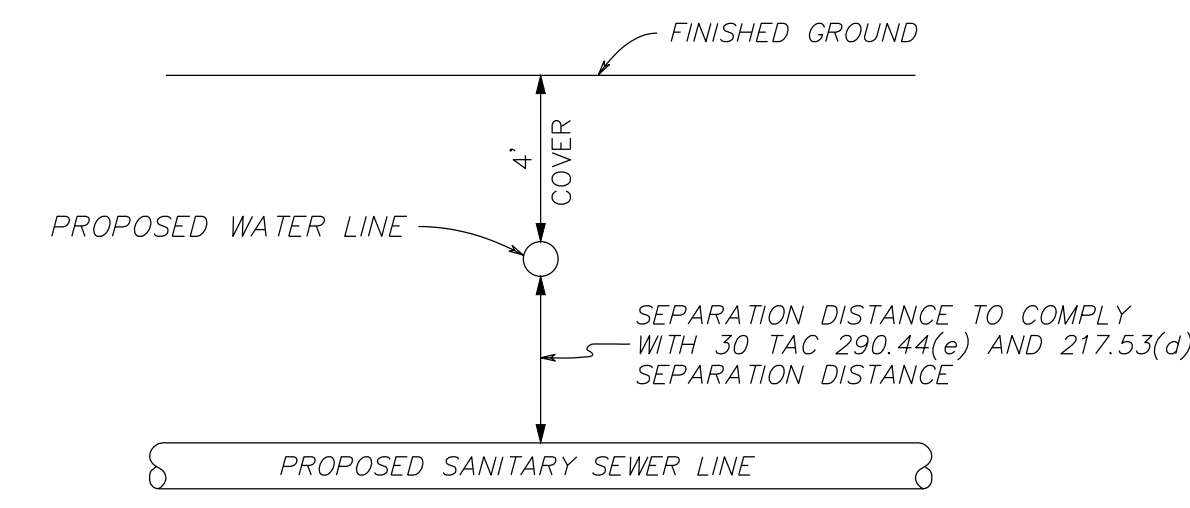

TYPICAL SANITARY SEWER/WATER CROSSING DETAIL
SEE SEWER PLAN AND PROFILES FOR ACTUAL LOCATION OF SEWER/WATER LINE CROSSING

NOTE: A 20' SEGMENT OF PRESSURE RATED SANITARY SEWER PIPE, SDR-26 ASTM D-2241, SHALL BE CENTERED AT EVERY WATER CROSSING.

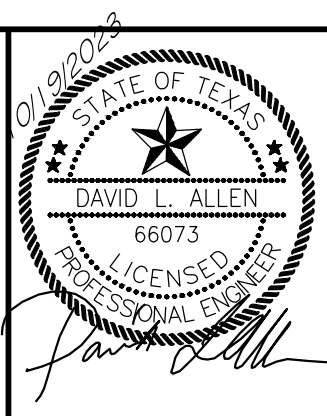

MACINA • BOSE • COPELAND & ASSOC., INC.
CONSULTING ENGINEERS AND LAND SURVEYORS
1035 Central Parkway North, San Antonio, Texas 78232
(210) 545-1122 Fax (210) 545-9302 www.mbcengineering.com
FIRM REGISTRATION NUMBER: T.B.P.E. F-784 & T.B.P.L.S. 10011700

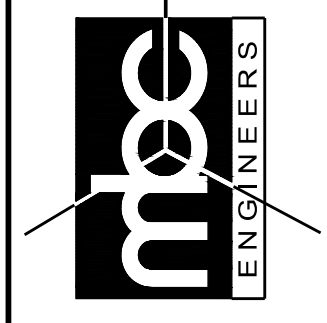

LANDMARK NORTH
SITE WORK AND UTILITY IMPROVEMENTS
SAN ANTONIO, TEXAS
SANITARY SEWER DETAILS

BY	
DESCRIPTION	
No.	
REVISIONS:	
DATE	
PLAT ID#	080586
APP#	RH
DESIGN	GM
DRAWN	DLA
CHECKED	DLA
DATE	03/21/2023
JOB NO.	30371-0976

\$5.00

NOTE:
REFERENCE GENERAL NOTES ON SHEET C02.00
PRIOR TO BID AND CONSTRUCTION

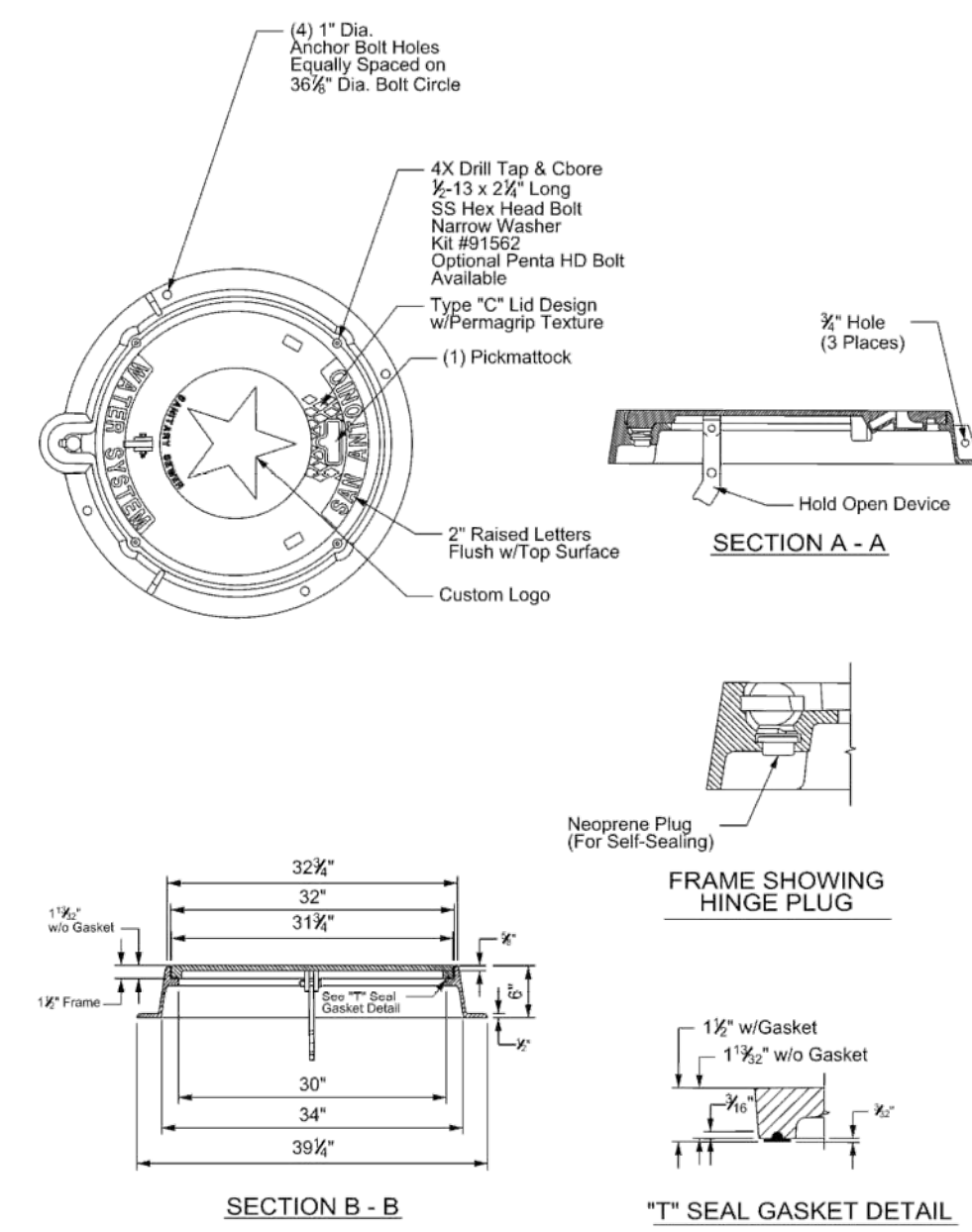

PROPERTY OF SAN ANTONIO WATER SYSTEM SAN ANTONIO, TEXAS	MANHOLE RING AND COVER DETAIL	APPROVED MARCH 2008	REVISED AUG 2019	DD-852-07	SHEET 5 OF 5
---	----------------------------------	------------------------	---------------------	-----------	-----------------

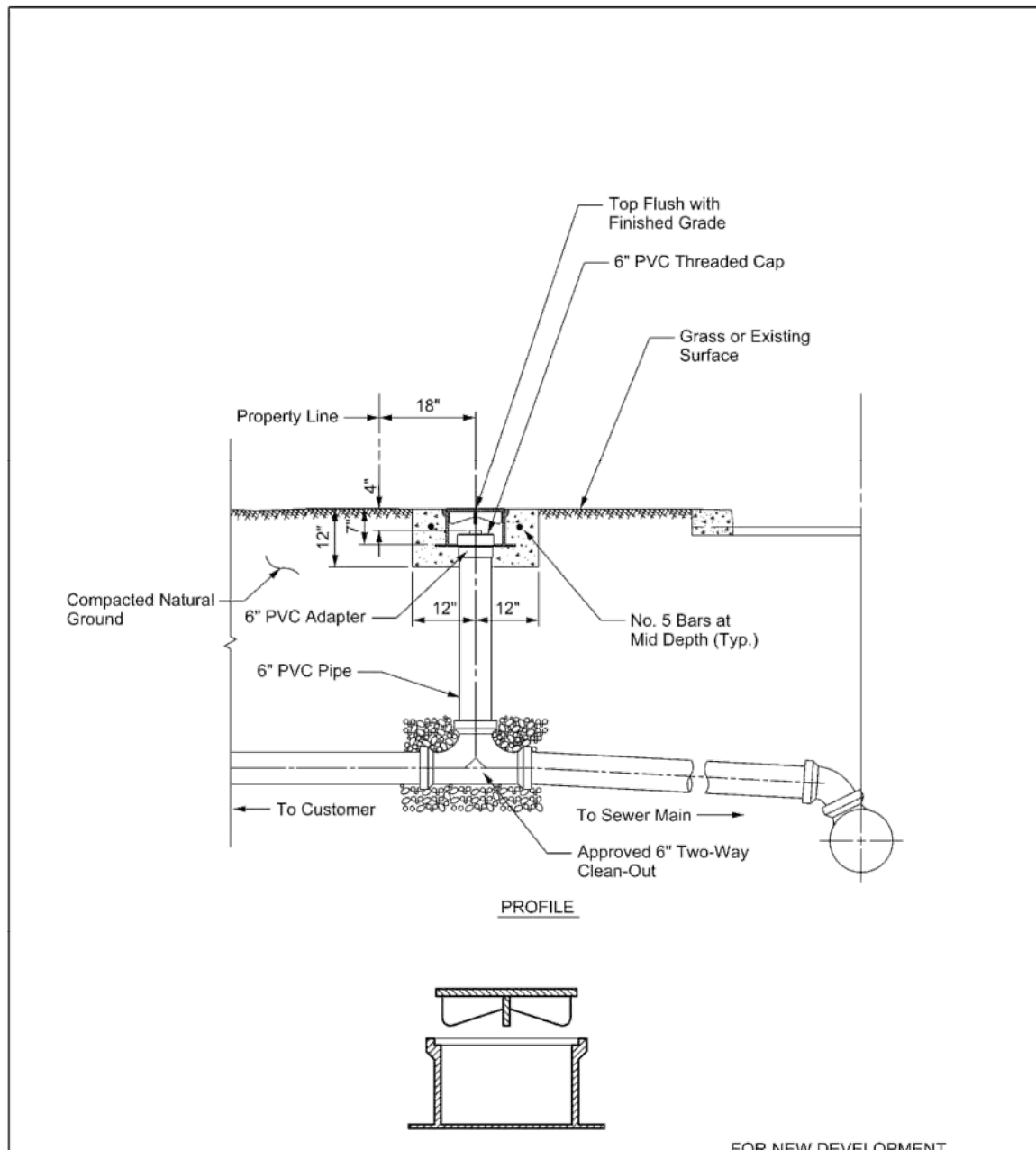

PROPERTY OF SAN ANTONIO WATER SYSTEM SAN ANTONIO, TEXAS	TYPICAL CLEANOUT DETAIL	APPROVED MARCH 2008	REVISED AUG 2019	DD-854-02	SHEET 1 OF 3
---	-------------------------	------------------------	---------------------	-----------	-----------------

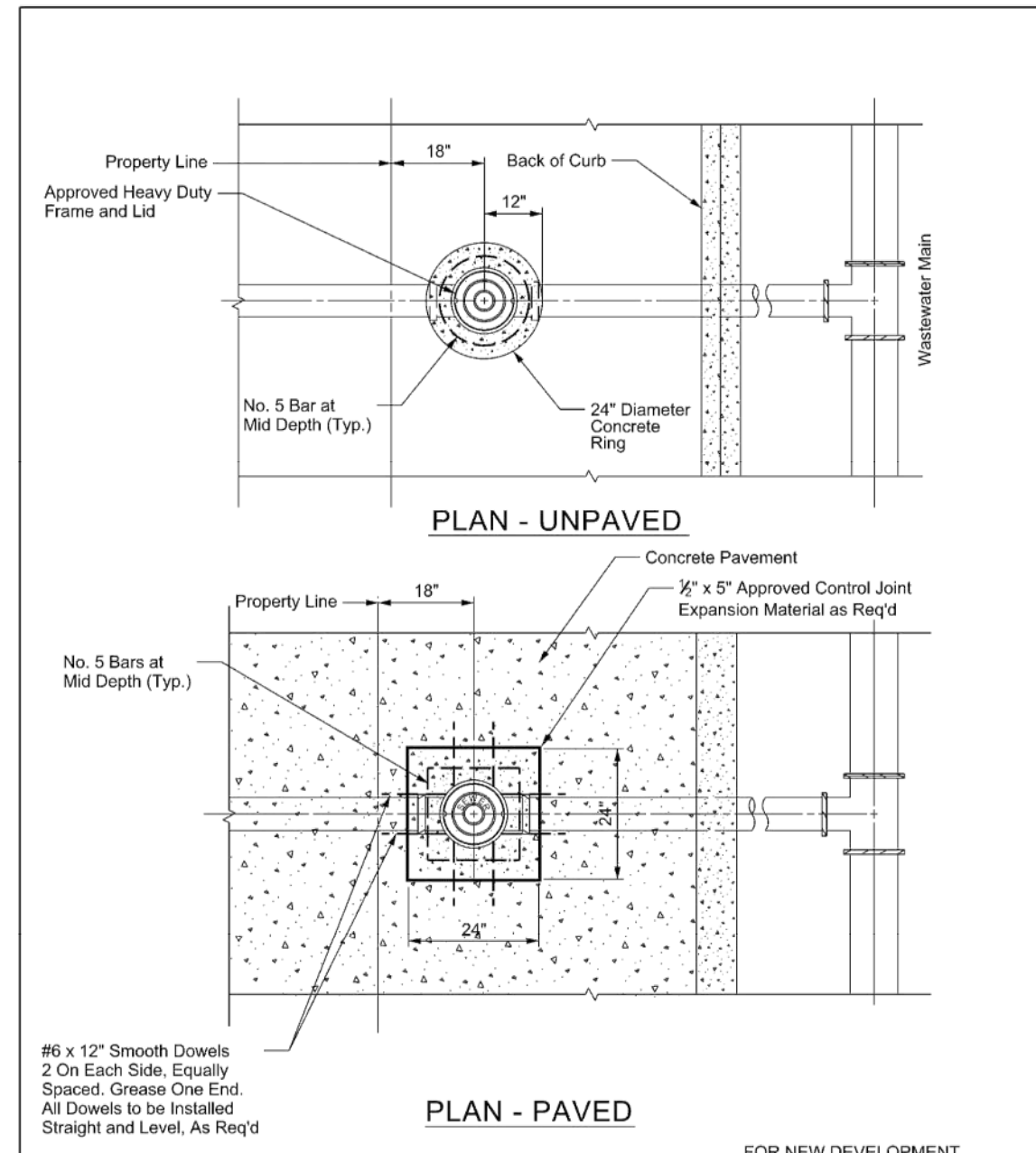

PROPERTY OF SAN ANTONIO WATER SYSTEM SAN ANTONIO, TEXAS	TYPICAL CLEANOUT DETAIL	APPROVED MARCH 2008	REVISED AUG 2019	DD-854-02	SHEET 2 OF 3
---	-------------------------	------------------------	---------------------	-----------	-----------------

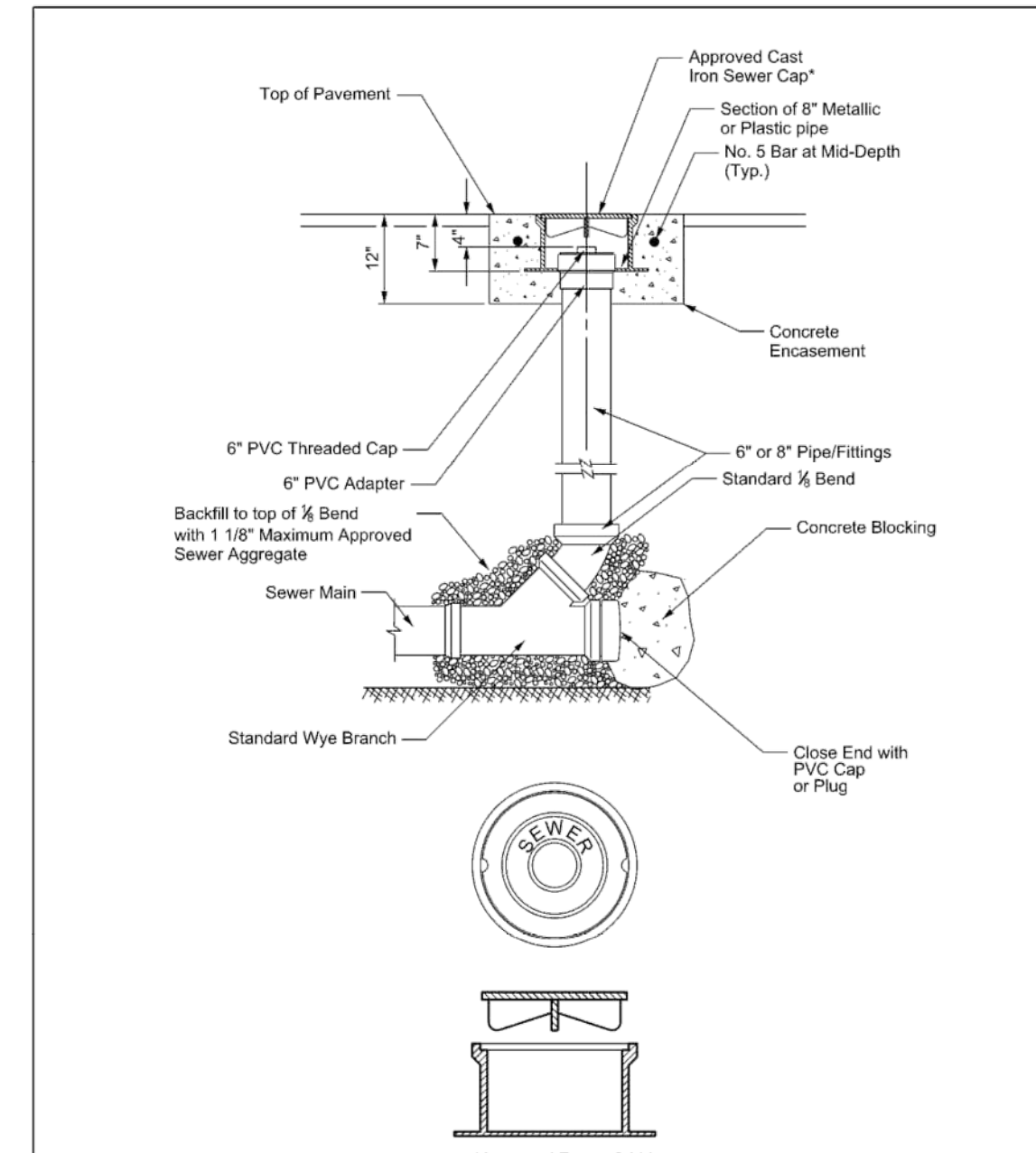

PROPERTY OF SAN ANTONIO WATER SYSTEM SAN ANTONIO, TEXAS	TYPICAL CLEANOUT DETAIL (ON DEAD-END MAIN)	APPROVED MARCH 2008	REVISED AUG 2019	DD-854-02	SHEET 3 OF 3
---	---	------------------------	---------------------	-----------	-----------------

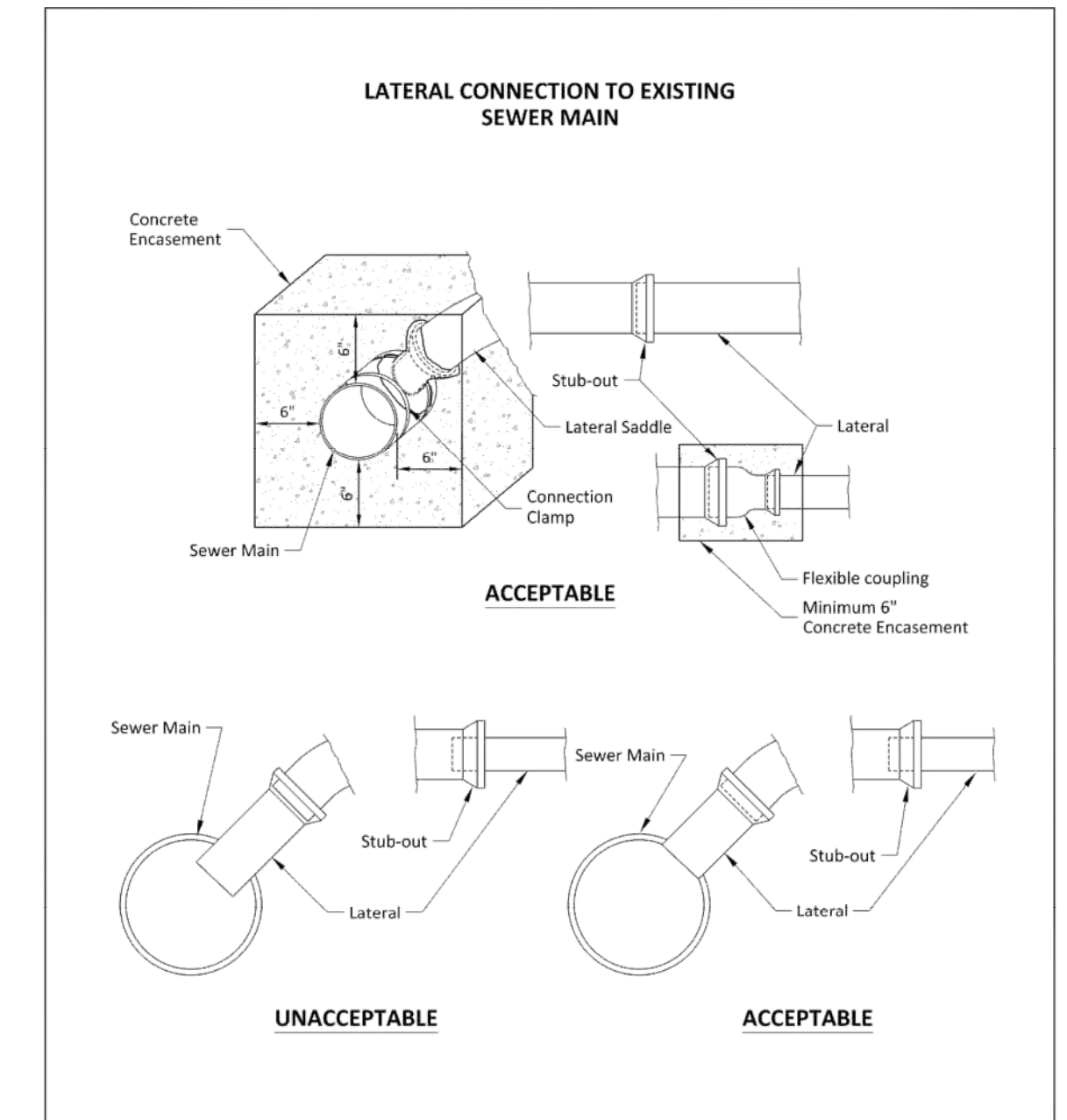

PROPERTY OF SAN ANTONIO WATER SYSTEM SAN ANTONIO, TEXAS	LATERAL CONNECTION	APPROVED MARCH 2008	REVISED December 2018	DD-854-03	SHEET 1 OF 1
---	--------------------	------------------------	--------------------------	-----------	-----------------

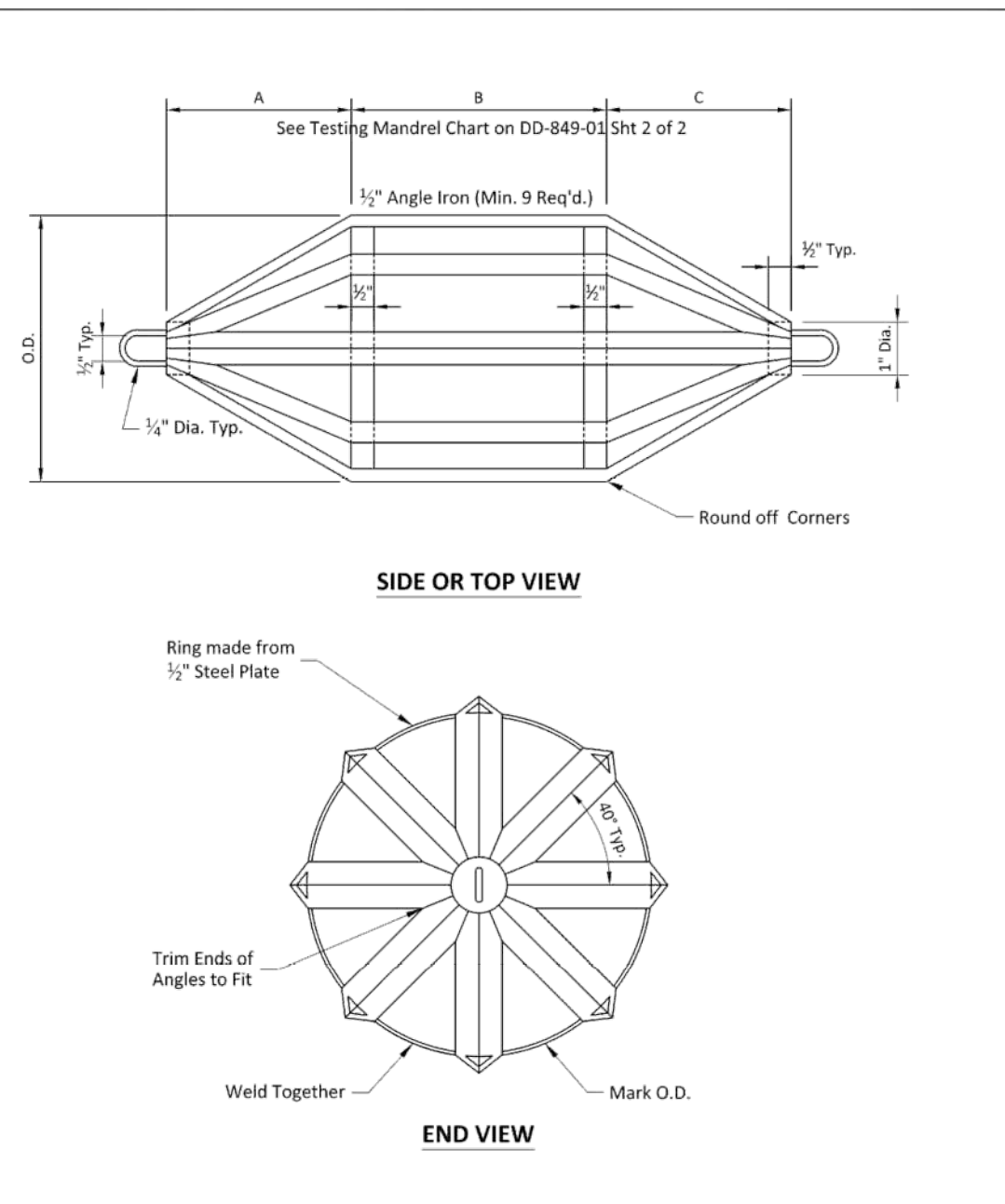

Note:
All Mandrels must be Approved by SAWS Construction Inspection
Dept. and Stamped before Use.

PROPERTY OF SAN ANTONIO WATER SYSTEM SAN ANTONIO, TEXAS	GO, NO GO DEFLECTION TESTING MANDREL	APPROVED March 2008	REVISED December 2019	DD-849-01	SHEET 1 OF 2
---	---	------------------------	--------------------------	-----------	-----------------

SIZE	MANDREL O.D.		RING O.D.
	A	B*	
6"	4.0"	4.5"	5.50
8"	5.5"	6"	7.37
10"	7.0"	7.5"	9.21
12"	8.0"	9"	10.96
15"	10.0"	11"	13.42
18"	12.0"	13.5"	
21"	14.0"	16"	
24"	16.0"	18"	
27"	18.0"	20"	

*Minimum Length

CHART

Notes:
PVC Pipes and Fittings 6" to 15" in Diameter shall Conform to ASTM D-2241
PVC Pipes and Fittings 18" to 27" in Diameter shall Conform to ASTM F-679

This information is provided as a reference. All deflection testing shall be done in accordance
with TCEQ Capter 217.

PROPERTY OF SAN ANTONIO WATER SYSTEM SAN ANTONIO, TEXAS	GO, NO GO DEFLECTION TESTING MANDREL CHART	APPROVED March 2008	REVISED December 2019	DD-849-01	SHEET 2 OF 2
---	---	------------------------	--------------------------	-----------	-----------------

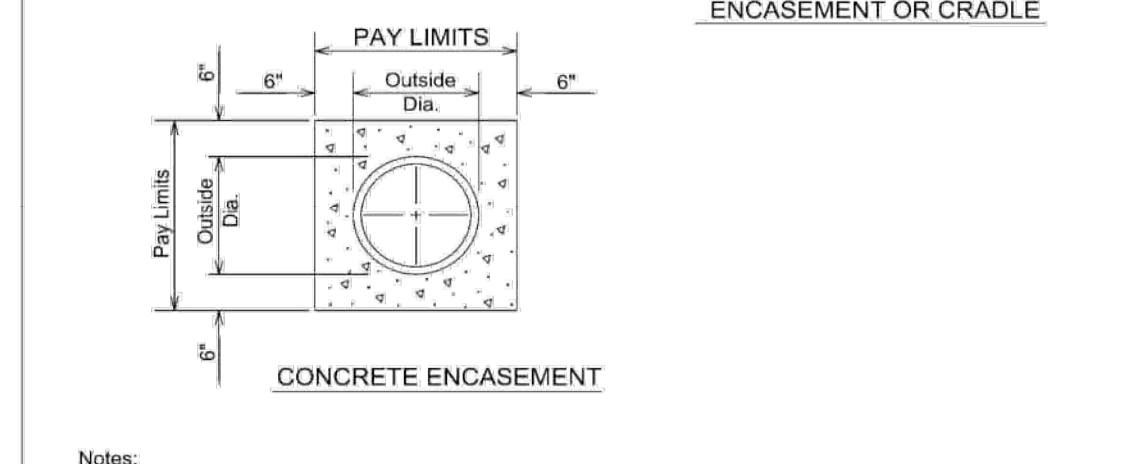
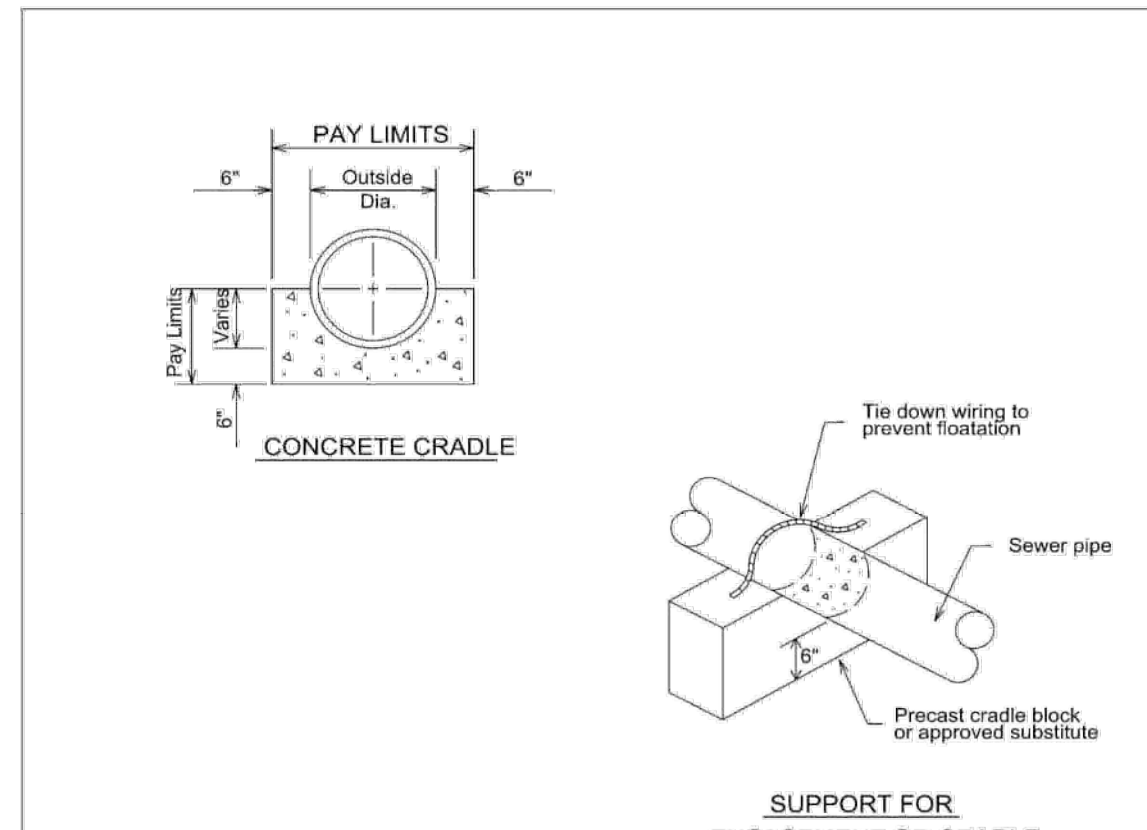

Notes:
1) All concrete encasement shall be poured at a plane 6" above the pipe between excavated trench walls.
2) All sewer pipe with less than 3" of cover to subgrade shall be concrete encased.
3) All Force mains shall be provided with thrust blocks, where changes in direction occur, at Tees, Bends,
Crosses, changes in size, stops, or as directed by SAWS.

PROPERTY OF SAN ANTONIO WATER SYSTEM SAN ANTONIO, TEXAS	TYPICAL CONCRETE ENCASEMENT DETAILS	APPROVED March 2008	REVISED AUG 2019	DD-858-01	SHEET 1 OF 1
---	--	------------------------	---------------------	-----------	-----------------

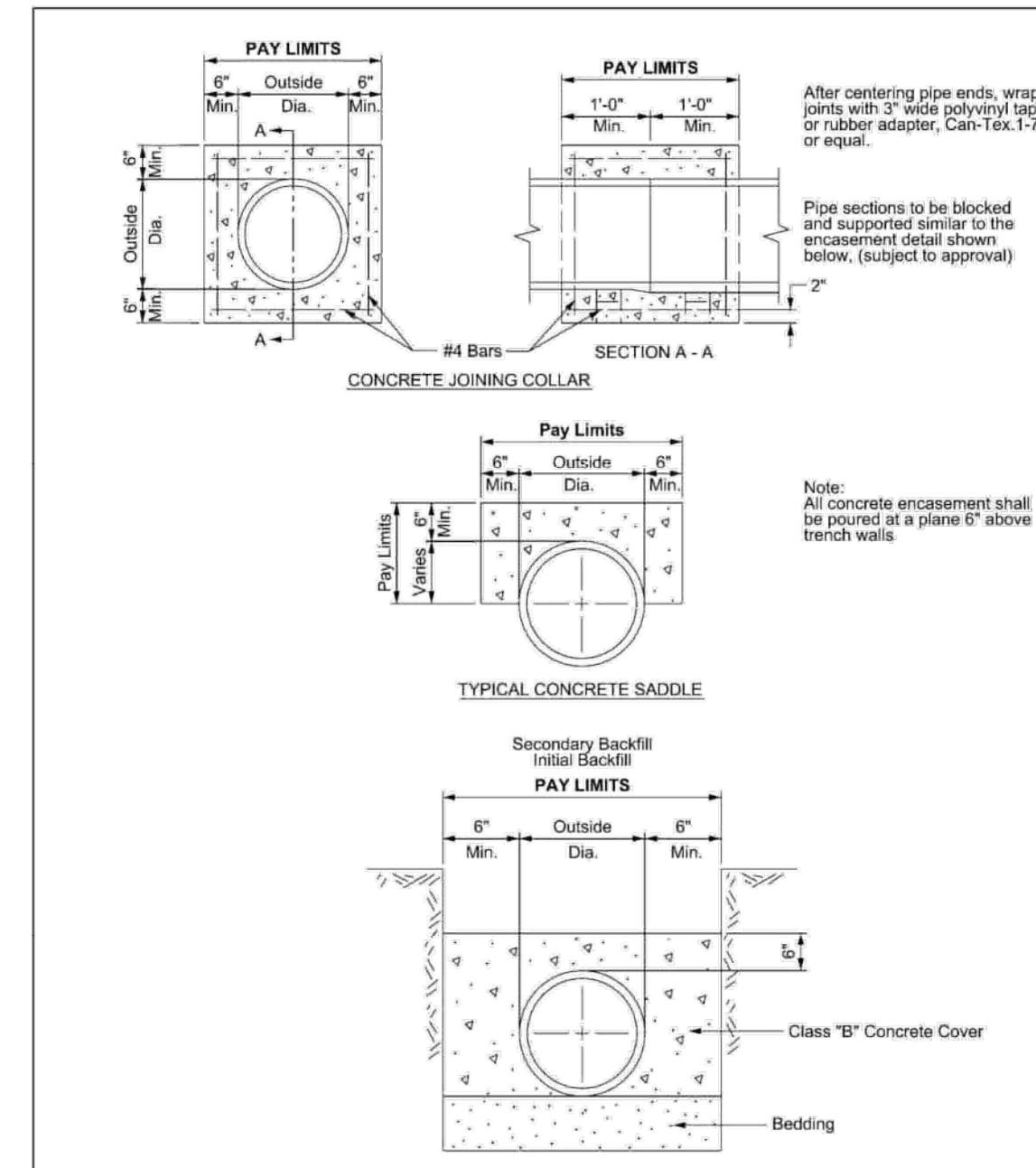

Notes:
1) All concrete encasement shall be poured at a plane 6" above the pipe between excavated trench walls.
2) All sewer pipe with less than 3" of cover to subgrade shall be concrete encased.
3) All Force mains shall be provided with thrust blocks, where changes in direction occur, at Tees, Bends,
Crosses, changes in size, stops, or as directed by SAWS.

PROPERTY OF SAN ANTONIO WATER SYSTEM SAN ANTONIO, TEXAS	TYPICAL CONCRETE DETAILS	APPROVED MARCH 2008	REVISED AUG 2019	DD-858-02	SHEET 1 OF 1
---	-----------------------------	------------------------	---------------------	-----------	-----------------

- NOTES:
- ALL PRUNING TO BE DONE SHOULD BE REVIEWED AND APPROVED BY THE SAWS INSPECTOR.
 - ALL TREE CUTS TO BE TREATED WITH AN APPROVED ASPHALTIC SEALING COMPOUND.
 - MAKE CUTS WITH SHARP INSTRUMENTS FLUSH AT COLLAR OF BRANCH, NOT AT TRUNK.
 - REMOVE TRIMMINGS FROM SITE.
 - ALL TREES IMPACTED BY EXCAVATION OR BORING SHALL BE FERTILIZED BY SOIL INJECTION IN A PATTERN BEGINNING 6 FEET FROM BASE OF TREE TO 10 FEET BEYOND THE DRIPLINE. INJECTIONS TO BE 12-18 INCHES DEEP APPROXIMATELY 3 FEET APART SO THAT 50 GALLONS OF MATERIAL IS DISTRIBUTED UNIFORMLY FOR EVERY 1000 SQUARE FEET OF ROOT AREA.

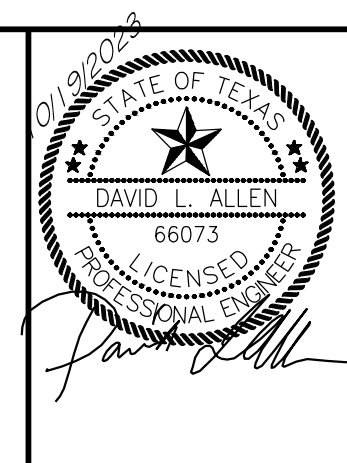
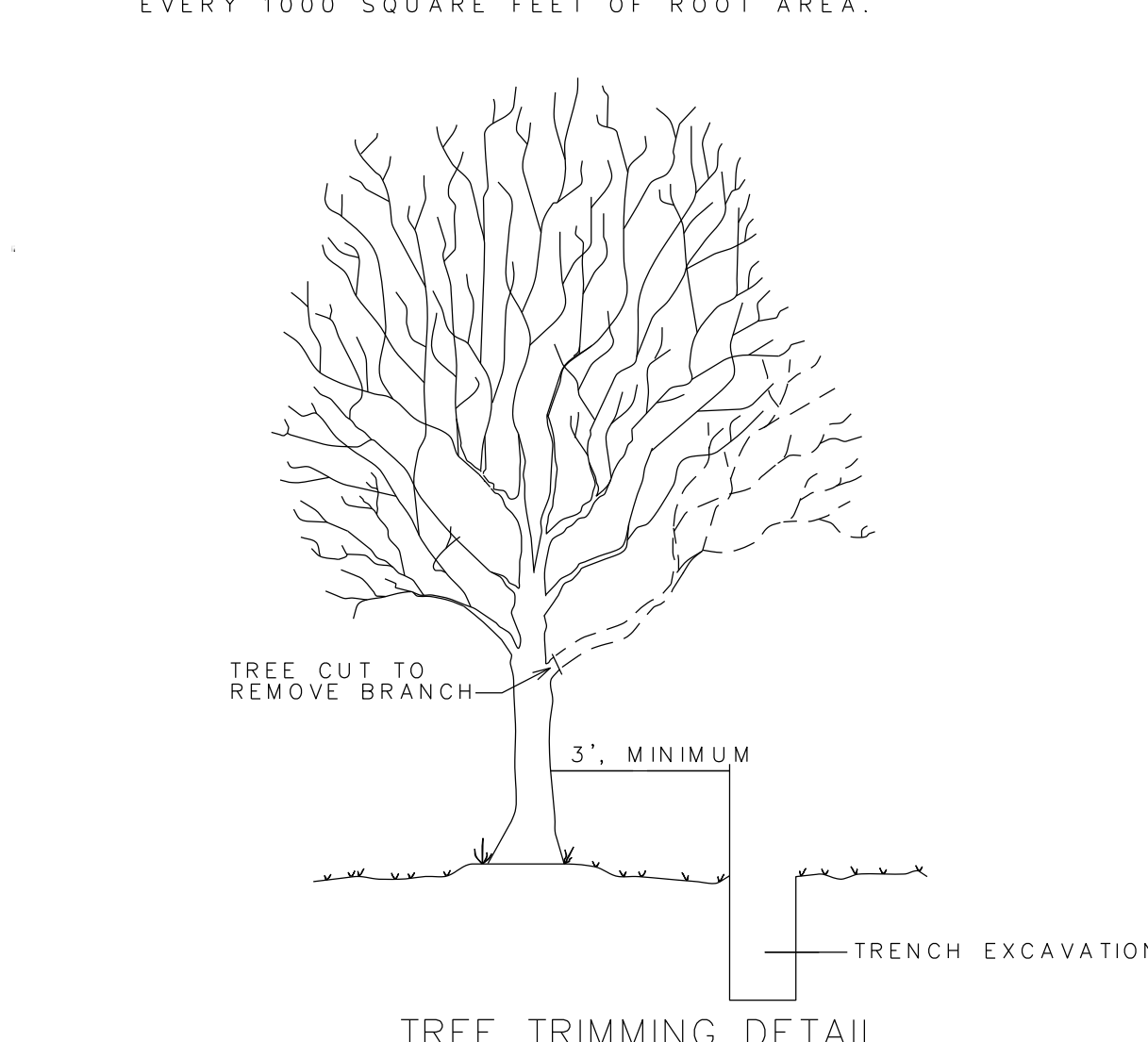

MACINA • BOSE • COPELAND & ASSOC., INC.
CONSULTING ENGINEERS AND LAND SURVEYORS
1035 Central Parkway North, San Antonio, Texas 78232
(210) 545-1122 Fax (210) 545-9002 www.mbcengineering.com
FIRM REGISTRATION NUMBER: T.B.P.E. F-784 & T.B.P.L.S. 10011700

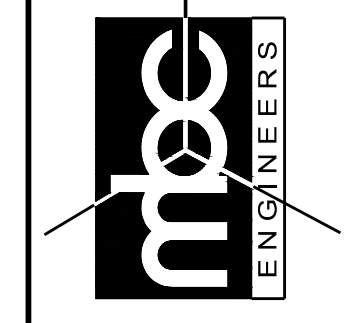

LANDMARK NORTH
SITE WORK AND UTILITY IMPROVEMENTS
SAN ANTONIO, TEXAS
SANITARY SEWER DETAILS - 2

REVISIONS:	DATE	DESCRIPTION
No.		
DATE		
DATE		

PLAT ID#	080586
APP#	RH
DESIGN	GM
DRAWN	DLA
CHECKED	
DATE	03/21/2023
JOB NO.	30371-0976

S5.01

Date: 03-19-2023, 10:35am User: D:\hndock Layout: SANITARY SEWER DETAILS - 2 File: P:\076\03071-Fulcrum_Landmark\Design\Drawings\Sanitary Sewer Details - 2.dwg Layout name: SANITARY SEWER DETAILS - 2

NOTE:
REFERENCE GENERAL NOTES ON SHEET C02.00
PRIOR TO BID AND CONSTRUCTION

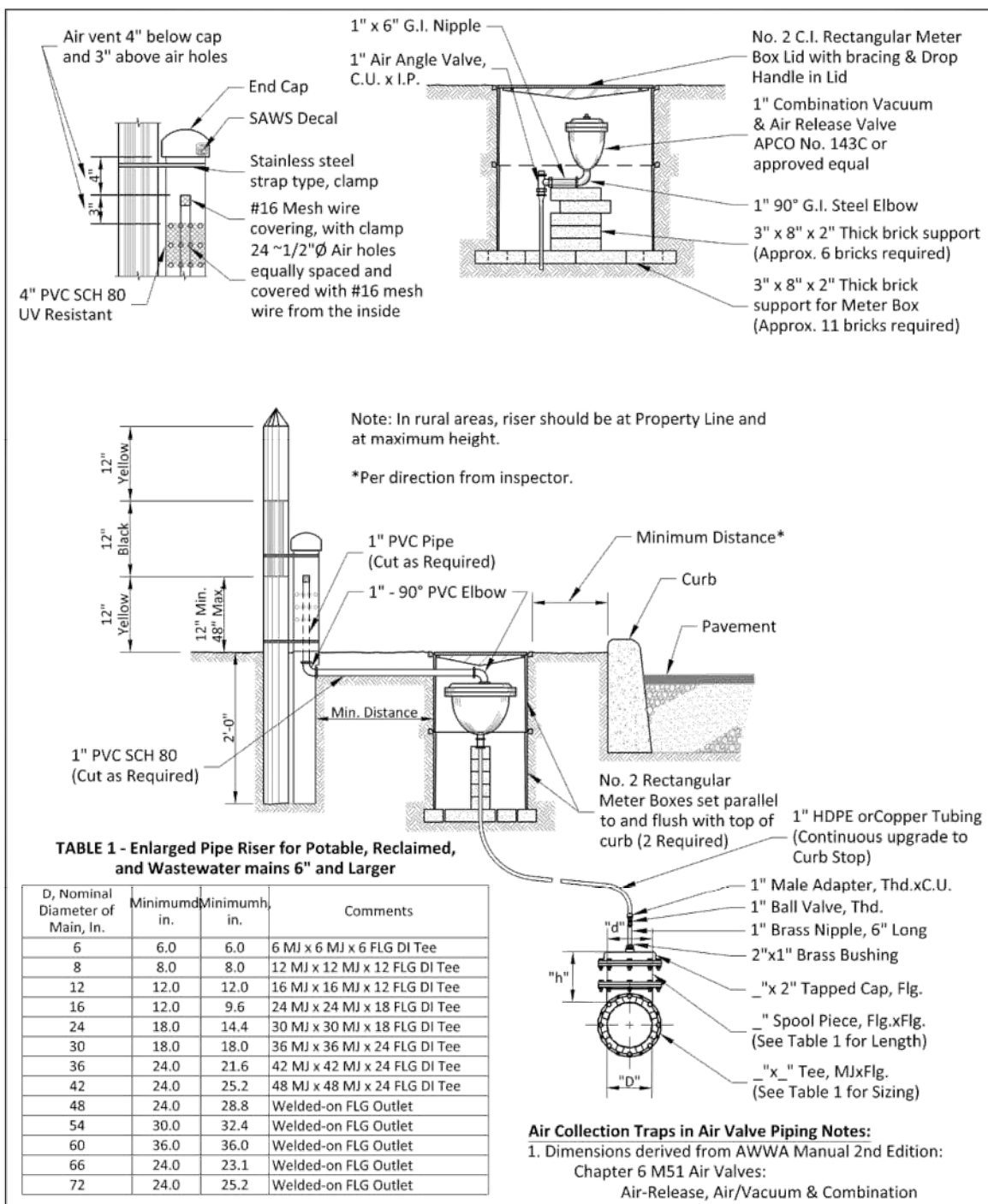

TABLE 1 - Enlarged Pipe Riser for Potable, Reclaimed, and Wastewater mains 6" and Larger

D, Nominal Diameter of Main, in.	Minimum Diameter, in.	Comments
6	6.0	6 MI x 6 MI x 6 FIG DI Tee
8	8.0	12 MI x 12 MI x 12 FIG DI Tee
12	12.0	18 MI x 18 MI x 18 FIG DI Tee
16	12.0	24 MI x 24 MI x 18 FIG DI Tee
24	18.0	30 MI x 30 MI x 18 FIG DI Tee
30	18.0	36 MI x 36 MI x 24 FIG DI Tee
36	24.0	42 MI x 42 MI x 24 FIG DI Tee
42	24.0	48 MI x 48 MI x 24 FIG DI Tee
48	24.0	48 MI x 48 MI x 24 FIG DI Tee
54	30.0	Welded-on FIG Outlet
60	36.0	Welded-on FIG Outlet
66	24.0	Welded-on FIG Outlet
72	24.0	Welded-on FIG Outlet

PROPERTY OF SAN ANTONIO WATER SYSTEM, SAN ANTONIO, TEXAS. INSTALLATION OF 1" AIR RELEASE VALVE. DD-846-01. SHEET 1 OF 1.

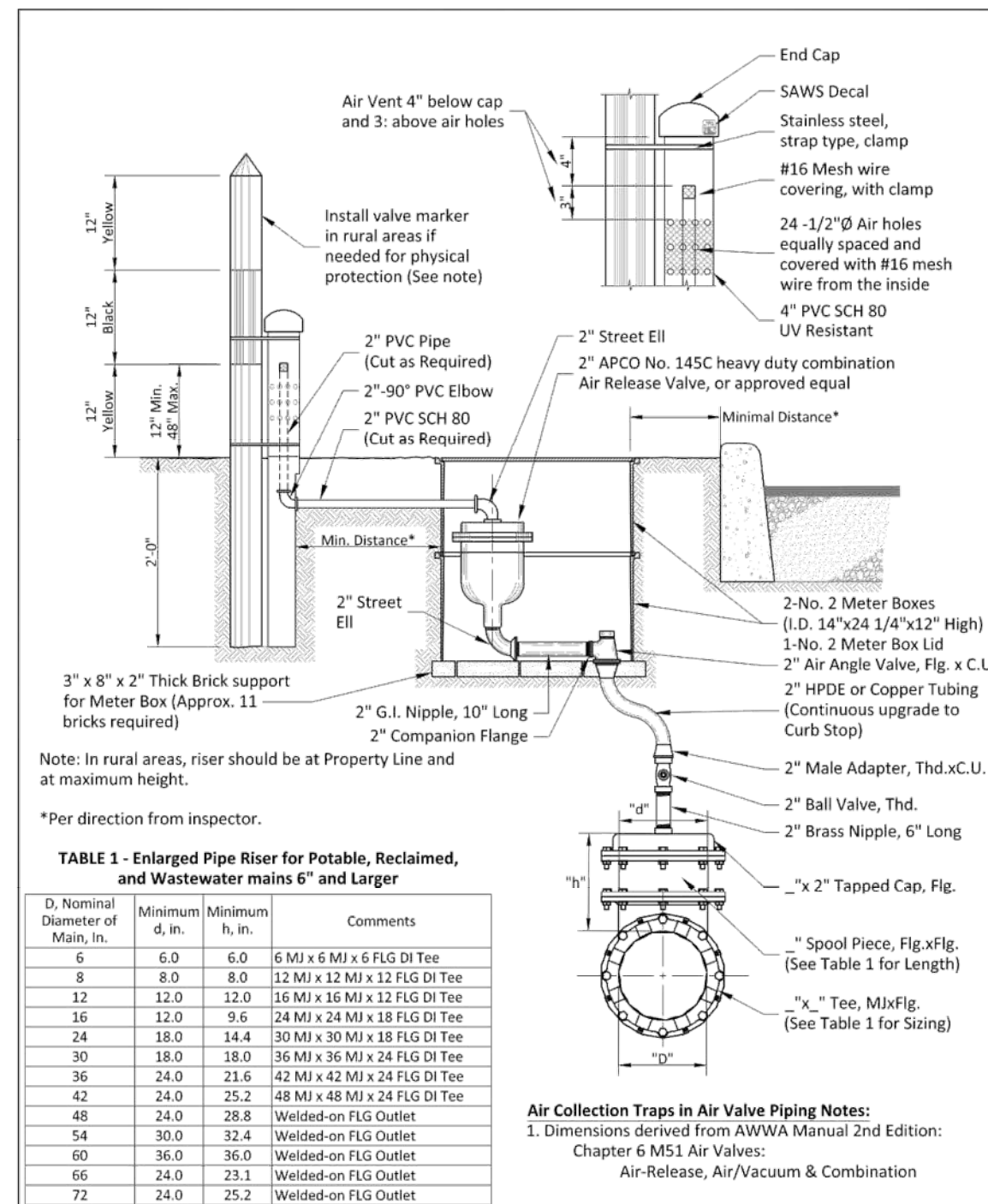
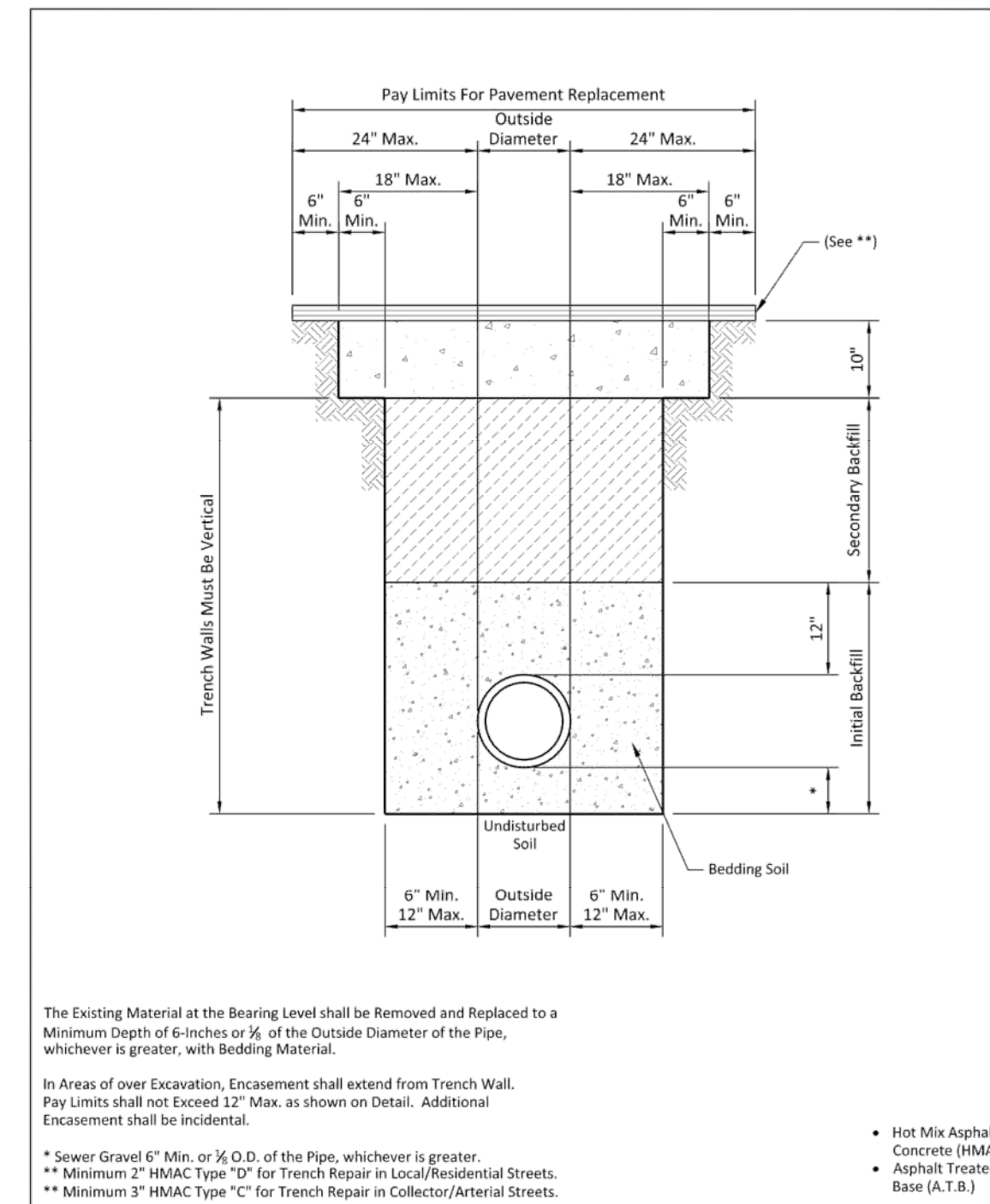

TABLE 1 - Enlarged Pipe Riser for Potable, Reclaimed, and Wastewater mains 6" and Larger

D, Nominal Diameter of Main, in.	Minimum Diameter, in.	Comments
6	6.0	6 MI x 6 MI x 6 FIG DI Tee
8	8.0	12 MI x 12 MI x 12 FIG DI Tee
12	12.0	18 MI x 18 MI x 18 FIG DI Tee
16	12.0	24 MI x 24 MI x 18 FIG DI Tee
24	18.0	30 MI x 30 MI x 18 FIG DI Tee
30	18.0	36 MI x 36 MI x 24 FIG DI Tee
36	24.0	42 MI x 42 MI x 24 FIG DI Tee
42	24.0	48 MI x 48 MI x 24 FIG DI Tee
48	24.0	48 MI x 48 MI x 24 FIG DI Tee
54	30.0	Welded-on FIG Outlet
60	36.0	Welded-on FIG Outlet
66	24.0	Welded-on FIG Outlet
72	24.0	Welded-on FIG Outlet

PROPERTY OF SAN ANTONIO WATER SYSTEM, SAN ANTONIO, TEXAS. INSTALLATION OF 2" AIR RELEASE VALVE. DD-846-02. SHEET 1 OF 1.



Pay Limits For Pavement Replacement

Outside Diameter	24" Max.	18" Max.	18" Max.	6" Min.	6" Min.
6" Min.	18" Max.	18" Max.	18" Max.	6" Min.	6" Min.

PROPERTY OF SAN ANTONIO WATER SYSTEM, SAN ANTONIO, TEXAS. SANITARY SEWER PIPE LAID IN TRENCH. DD-804-01. SHEET 1 OF 1.

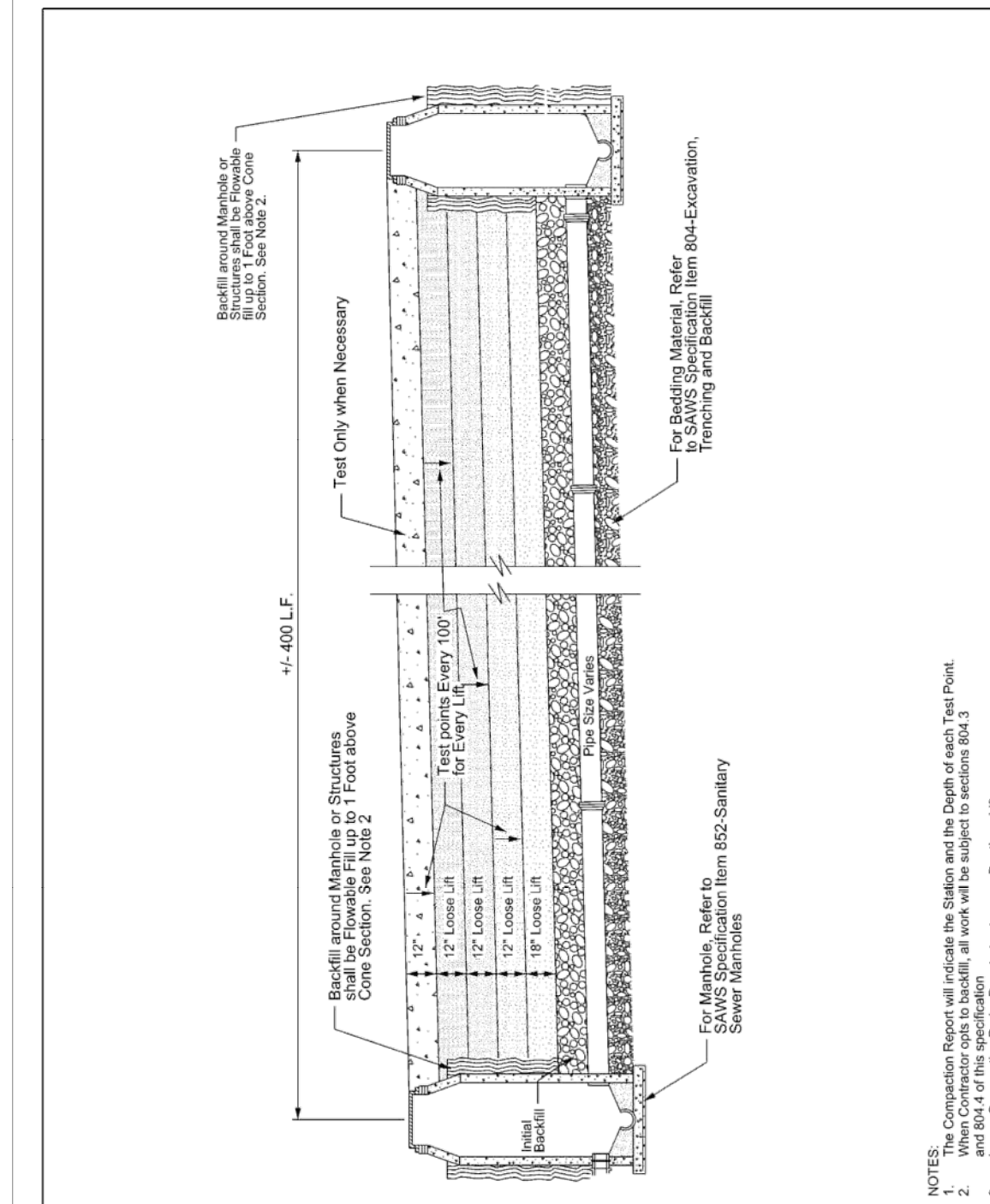

Pay Limits For Pavement Replacement

Outside Diameter	24" Max.	18" Max.	18" Max.	6" Min.	6" Min.
6" Min.	18" Max.	18" Max.	18" Max.	6" Min.	6" Min.

PROPERTY OF SAN ANTONIO WATER SYSTEM, SAN ANTONIO, TEXAS. TRENCH COMPACTION DETAIL. DD 804-02. SHEET 1 OF 1.

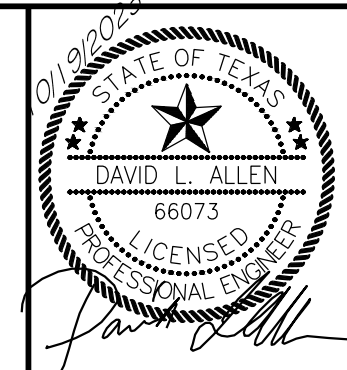

MACINA • BOSE • COPELAND & ASSOC., INC.
CONSULTING ENGINEERS AND LAND SURVEYORS
1035 Central Parkway North, San Antonio, Texas 78232
(210) 545-1122 Fax (210) 545-9002 www.mbcengineers.com
FIRM REGISTRATION NUMBER: T.B.P.E. F-784 & T.B.P.L.S. 10011700

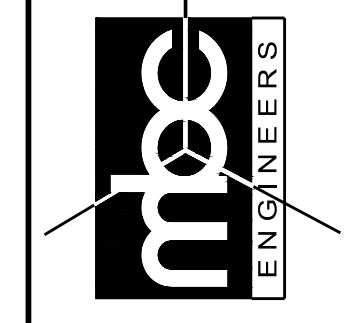

LANDMARK NORTH
SITE WORK AND UTILITY IMPROVEMENTS
SAN ANTONIO, TEXAS
SANITARY SEWER DETAILS - 3

REVISIONS:	DATE	DESCRIPTION

PLAT ID# 080586
APR _____
DESIGN RH
DRAWN GM
CHECKED DLA
DATE 03/21/2023
JOB NO. 30371-0976

S5.02

– **Lift Station / Force Main System Application Form (TCEQ-0624)**

Attachment A – Engineering Design Report

Site Plan

Final Plan and Profile Sheets

Lift Station/Force Main System Application

Texas Commission on Environmental Quality

for Regulated Activities On the Edwards Aquifer Recharge Zone and Relating to 30 TAC §213.5(c)(3)(B)and(c), Effective June 1, 1999

To ensure that the application is administratively complete, confirm that all fields in the form are complete, verify that all requested information is provided, consistently reference the same site and contact person in all forms in the application, and ensure forms are signed by the appropriate party.

Note: Including all the information requested in the form and attachments contributes to more streamlined technical reviews.

Regulated Entity Name: Landmark North - West

Customer Information

(If different than customer information provided on core data form)

1. The person(s) responsible for providing the engineering certification to the TCEQ pursuant to 30 TAC §213.5(f)(2)(C) during construction and 30 TAC §213.5 (c)(3)(D) upon completion of construction is:

Contact Person: Benjamin Dreszer

Entity: IH10/Loop 1604 Partners, LTD.

Mailing Address: 10003 NW Military Hwy, Suite 2205

City, State: San Antonio, Texas

Zip: 78231

Telephone: (210) 593-0777

Fax: (210) 593-0780

Email Address: benjamin@fulcrumsa.com

2. The engineer responsible for the design of this lift station and force main:

Contact Person: Richard Hendrix, P.E.

Entity: MBC Engineers

Mailing Address: 1035 Central Parkway North

City, State: San Antonio, Texas

Zip: 78232

Telephone: (210) 545-1122

Fax: (210) 545-9302

Email Address: rhendrix@mbcengineers.com

Texas Licensed Professional Engineer's Serial Number: 107385

Project Information

3. This project is for the construction or replacement of:

Lift Station only.

- Lift Station and Force Main system.
- Lift Station, Force Main, and Gravity system.

4. The sewage collection system will convey the wastewater to the Steven M. Clouse (name) Treatment Plant. The treatment facility is:

- Existing
- Proposed

5. All components of this lift station/force main system will comply with:

- The City of San Antonio (SAWS) standard specifications.
- Other. Specifications are attached.

Site Plan Requirements

Items 6-14 must be included on the Site Plan.

- 6. The Site Plan must have a minimum scale of 1" = 400'.
Site Plan Scale: 1" = 20'.
- 7. Lift station/force main system layout meets all requirements of 30 TAC Chapter 217.
- 8. Geologic or Manmade Features:
 - No geologic or manmade features were identified in the Geologic Assessment.
 - All geologic or manmade features identified in the Geologic Assessment (caves, solution openings, sinkholes, fractures, joints, porous zones, etc.) which exist at the site of the proposed lift station and along the path(s) or within **50 feet of each side** of a proposed force main line are shown on the Site Plan and are listed in the table below. Designs used to protect the integrity of the sewer line crossing each feature are described and labeled on the attached page. A detailed design drawing for each feature is shown on Plan Sheet _____ of _____.
 - No Geologic Assessment is required for this project.

Table 1 - Geologic or Manmade Features

<i>Line</i>	<i>Station to Station</i>	<i>Type of Feature</i>
N/A	to	
	to	
	to	
	to	
	to	
	to	
	to	
	to	

9. Existing topographic contours are shown and labeled. The contour interval is 1 feet. (Contour interval must not be greater than 5 feet).
10. Finished topographic contours are shown and labeled. The contour interval is 1 feet. (Contour interval must not be greater than 5 feet).
- Finished topographic contours will not differ from the existing topographic configuration and are not shown.

11. 100-year floodplain boundaries

- Some part(s) of the project site is located within the 100-year floodplain. The floodplain is shown and labeled.
- No part of the project site is located within the 100-year floodplain.

The 100-year floodplain boundaries are based on the following specific (including date of material) sources(s): _____

12. 5-year floodplain:

- After construction is complete, no part of this project will be in or cross a 5-year floodplain, either naturally occurring or manmade. (Do not include streets or concrete-lined channels constructed above sewer lines.)
- After construction is complete, all sections of the force main located within the 5-year floodplain will be encased in concrete or capped with concrete. These locations are listed in the table below and are shown and labeled on the Site Plan. (Do not include streets or concrete-lined channels constructed above sewer lines.)

Table 2 - 5-Year Floodplain

<i>Line</i>	<i>Sheet</i>	<i>Station to Station</i>
N/A	of	to
	of	to
	of	to
	of	to

13. All known wells (oil, water, unplugged, capped and/or abandoned, test holes, etc.):

If applicable, this must agree with Item No. 15 on the Geologic Assessment Form.

- There are _____ (#) wells present on the project site and the locations are shown and labeled. (Check all of the following that apply)
- The wells are not in use and have been properly plugged.
- The wells are not in use and will be properly plugged.
- The wells are in use and comply with 16 TAC Chapter 76.

There are no wells or test holes of any kind known to exist on the project site.

14. Legal boundaries of the site are shown.

Plan and Profile Sheets

The construction drawings and technical specifications will not be considered for review unless they are the **final plans and technical specifications** which will be used by the contractor for bidding and construction.

Items 15 – 18 must be included on the Plan and Profile sheets.

15. The equipment installation construction plans must have a minimum scale of 1" = 10'.
Plan sheet scale: 1" = 20 '.
16. Locations, descriptions and elevations of all required equipment and piping for the lift station and force main are shown and labeled.
17. Air Release/Vacuum Valves will be provided at all peaks in elevation of the proposed force main. These locations are listed in the table below and labeled on the appropriate plan and profile sheets.

Table 3 - Air Release/Vacuum Valves

<i>Line</i>	<i>Station</i>	<i>Sheet</i>
		of
		of
		of
		of
		of
		of

18. The **final plans and technical specifications** are submitted for the TCEQ's review. Each sheet of the construction plans and specifications are dated, signed, and sealed by the Texas Licensed Professional Engineer responsible for the design on each sheet.
19. **Attachment A - Engineering Design Report.** An engineering design report with the following required items is attached:
 - The report is dated, signed, and sealed by a Texas Licensed Professional Engineer.
 - Calculations for sizing system.
 - Pump head calculations, including, but not limited to, system head and pump capacity curves, head loss calculations, and minimum and maximum static head C values for normal and peak operational conditions.
 - 100-year and 25-year flood considerations.
 - Total lift station pumping capacity with the largest pump out of service.
 - Type of pumps, including standby units.
 - Type of pump controllers, including standby air supply for bubbler controllers, as applicable.

- Pump cycle time.
- Type of wet well ventilation; include number of air changes for mechanical ventilation.
- Minimum and maximum flow velocities for the force main.
- Lift station security.
- Lift station emergency provisions and reliability.

Administrative Information

- 20. Upon completion of the wet well excavation, a geologist must certify that the excavation was inspected for the presence of sensitive features and submit the signed, sealed, and dated certification to the appropriate regional office.
- 21. The TCEQ Lift Stations and Force Mains General Construction Notes (TCEQ-0591) are included on the General Notes Sheet of the Final Construction Plans for this lift station and/or force main system.
- 22. Submit one (1) original and one (1) copy of the application, plus additional copies as needed for each affected incorporated city, groundwater conservation district, and county in which the project will be located. The TCEQ will distribute the additional copies to these jurisdictions. The copies must be submitted to the appropriate regional office.
- 23. Any modification of this lift station/force main system application will require TCEQ approval, prior to construction, and may require submission of a revised application, with appropriate fees.

Signature

To the best of my knowledge, the responses to this form accurately reflect all information requested concerning the proposed regulated activities and methods to protect the Edwards Aquifer. This **Lift Station/Force Main System Application** is hereby submitted for TCEQ review and executive director approval. The system was designed in accordance with the requirements of 30 TAC §213.5(c)(3)(C) and 30 TAC Chapter 217, and prepared by:

Print Name of Licensed Professional Engineer: Richard Hendrix, P.E.

Place engineer's seal here:



Date: 10/19/2023

Signature of Licensed Professional Engineer

Richard W. Hendrix

TABLE OF CONTENTS

INTRODUCTION2

PUMP STATION AND FORCE MAIN DESIGN CALCULATIONS2

Average Dry Weather Flow3

Peak Dry Weather Flow3

Minimum Pump Requirements3

Storage Requirements5

Buoyancy Calculations5

Pump Cycle Time.....6

Lift Station Security6

LANDMARK NORTH - WEST RETAIL – LIFT STATION ENGINEERING REPORT

This Engineering Design Report has been prepared to comply with the Texas Commission on Environmental Quality's Design Criteria for Domestic Wastewater Systems (30 TAC 217), and regulations over the Edwards Aquifer Recharge Zone (30 TAC 213). Please note that throughout this application, the more stringent of SAWS or TCEQ regulations shall apply.

INTRODUCTION

The proposed site is located southeast of the intersection of IH 10 and Loop 1604 within the overall Landmark development. The lift station will not be located within the 100-year floodplain per FEMA FIRM panel no. 48029C0230G dated September 29, 2010. The Landmark North-West Lift Station construction will consist of a private lift station designed to serve 8,490 square feet of restaurant space. The lift station will be pumped through 315 linear feet of private force main (size 6") and will connect to a proposed sanitary sewer manhole located just outside of the Edwards Aquifer Recharge Zone. The public sewer main will be connected to an existing public sewer system that is located south of the subject tract. The existing 8" main is located within an existing sewer easement on private property.

The overall tract that the sewer collection system will serve is approximately 12.139 acres and a portion of the overall site is located within the Edwards Aquifer Recharge Zone. The "site area" which is considered a 100' envelope around the proposed sewer alignment is approximately 2.5 acres.

This project is located within the city limits of San Antonio and San Antonio Water Systems (SAWS) will supply potable water to the project. Approximately 5,940 gallons per day of domestic wastewater is estimated to be generated by the restaurant and will be discharged into the proposed SCS submitted concurrently with the lift station. This daily flow value accounts for the peak flow and external contributions as required by the San Antonio Water System Utility Service Regulations 11.3.1. Wastewater is disposed of by conveyance to the existing Steven M. Clouse Water Recycling Center operated by SAWS.

Please refer to the overall site plan of the attached sewer plans, which show the proposed service area and its topographic features. There are no current plans for future expansion at this time. For information regarding the capability of the existing system and facilities to handle this increased flow, please see copy of the SAWS Utility Service Agreement (USA) attached. This system is designed to have a minimum structural life of 50 years. Safety considerations are the responsibility of the contractor. Refer to SAWS Item Nos. 550 and 902 for construction safety information. Safety protection shall be accomplished in accordance with the most recent requirements of the Occupational Safety and Health Administration Standards and Interpretations.

PUMP STATION AND FORCE MAIN DESIGN CALCULATIONS

Basis for average flow used for design of collection system (**check one or more**):

**LANDMARK NORTH - WEST RETAIL – LIFT STATION
ENGINEERING REPORT**

Average Dry Weather Flow

Thirty (30) EDU will flow to the lift station from the 8,570 sf restaurant space. For each EDU, the average daily flow is 200 gallons per day. This yields an average daily flow into the lift station of 6,000 gallons per day (gpd) (30 EDU x 200 gpd). Dividing by 1,440 minutes/day gives a flow of 4.17 gallons per minute (gpm).

Peak Dry Weather Flow

Peaking Factor used for design: 2.5

Peaking Factor is based on: SAWS Specifications for peak dry weather flow (from SAWS USR 11.3.1)

In order to determine peak flows for the collection system, the peaking factor of 2.5 is applied to the average daily flow. This yields a peak flow of 15,000 gpd (30 EDU x 200 gpd x 2.5). Dividing by 1,440 minutes/day gives a flow of 10.42 gpm.

Peak Wet Weather Flow

In order to determine peak wet weather flow, a component must be added to the peak dry weather flow to account for inflow and infiltration to the collection system. This inflow and infiltration is computed based on the SAWS value of 600 gpd per acre of land in the service area. The service area for the proposed lift station is approximately 7.9 acres. This give an inflow and infiltration flow of 4,740 gpd (7.9 acres x 600 gallons/day/acre). Adding this to the peak dry weather flow of 15,000 gpd gives a daily peak wet weather flow of 19,740 gpd. Dividing by 1,440 minutes/day gives a flow of 13.71 gpm.

Minimum Dry Weather Flow

The minimum dry weather flow is used to determine the maximum detention time in the wet well. The formula for computing the minimum dry weather flow (as given in the SAWS Lift Station Design Guidelines) is:

$$MDWF = (0.2 \times (0.0144 \times ADF)^{.198}) \times ADF,$$

where MDWF is the minimum dry weather flow and ADF is the average dry weather flow. Using the above equation and an average dry weather flow of 4.17 gpm gives a value of 0.48 gpm for the minimum dry weather flow.

Minimum Pump Requirements

For a lift station with a peak flow of less than 120 gpm the pump must be submersible and include a grinder. Since only one pump will be installed in the proposed lift station, it must be capable of handling the peak wet weather flow at the required total dynamic head.

The total dynamic head (TDH) can be described by the following equation:

$$TDH = H_s + L_f + L_m$$

**LANDMARK NORTH - WEST RETAIL – LIFT STATION
ENGINEERING REPORT**

where H_s is the static head, L_f is the loss due to friction in the force main pipe and L_m is the minor loss in the force main pipe. The static head can be described by the following equation:

$$H_s = E_H - E_L$$

Where E_H is the maximum elevation of the proposed force main and the E_L is the low water elevation of the wet well. Per TCEQ Regulations (Chapter 317.3 (c)(4)), a static head must be computed using two different low water elevations. The “All Pump Off” Elevation (E_{L1}) and the “First Pump On” Elevation (E_{L2}) will be used to compute the two required static heads.

The frictional losses in the force main pipe can be described by the following equation:

$$L_f = L \times ((2.313 \times Q) / (C \times D^{2.63}))^{1.85}$$

where:

- L = length of force main, feet
- Q = flow, cubic feet per second
- C = Hazen-Williams factor of the pipe
- D = diameter of the force main, feet

Per TCEQ Regulations (Chapter 317.3 (c)(4)), the losses due to the friction must be computed using a C value of 100 (C_1) and 140 (C_2). This will produce two L_f values, L_{f1} and L_{f2} .

The minor losses in the force main pipe can be described by the following equation:

$$L_M = (Kv^2) / (2g)$$

where:

- K = headloss coefficient for the minor losses
- v = velocity in the force main ($Q / (\pi(D/2)^2)$), feet per second
- g = gravitational constant (32.2 ft²/sec)

Thus, the equation for determining TDH can be written as follows:

$$TDH = E_H - E_L + L \times ((2.313 \times Q) / (C \times D^{2.63}))^{1.85} + (Kv^2) / (2g) \times (Q / (\pi(D/2)^2))$$

Using the two different low water elevations (E_{L1} and E_{L2}) and two different C values (C_1 and C_2), four different combinations of these values can be used and four different TDH values will be determined. Table 2 contains the remaining variables from the TDH equation, the four different combinations of EL and C values and the four resulting TDH values.

Appendix C contains pump curves and supporting information for Liberty Pump LGV02 2.5 Hp grinder pump. The pump curve is based on the information supplied by Smith Pump Company.

LANDMARK NORTH - WEST RETAIL – LIFT STATION ENGINEERING REPORT

Based on the pump curve supplied by Smith Pump Company, the design point for the Landmark North – West Retail Lift Station will have a flow of 52 gpm and a dynamic head of 15 feet. This value exceeds the maximum daily inflow and is therefore sufficient to serve the required area.

Net Positive Suction Head (NPSH)

NPSH calculations are not critical for submersible pumps. Since the Landmark North – West Retail Lift Station will use a Liberty Pump LGV02 submersible grinder pump, NPSH calculations are not required.

Velocity in Force Main

The force main proposed for this project is a 3-inch PVC ASTM D2241, SDR 26, Class 160 force main. The velocity (v) in the force main can be described by the following equation:

$$V = Q/A$$

where:

Q = flow in the force main, cubic feet per second

A = area of the force main [$\pi(D/2)^2$], square feet

For the proposed 3-inch force main, the area of the pipe is 0.049 square feet ($A = \pi(D/2)^2$). Converting the design flow of 52 gpm to cubic feet per second gives a flow of 0.116 cfs (52 gpm / (7.480519 gallons/cubic foot x 60 seconds/minute)). This yields a velocity in the force main of 2.36 feet per second. Note that this is within the allowable range of 3 to 6 feet per second.

Storage Requirements

The required wet well volume (volume between the “First Pump On” elevation and the “All Pumps Off” elevation) is governed by TCEQ Regulations (Chapter 317.3 (b)(4)(B)) which states that submersible pumps must not be required to start more than 10 times per hour. This rule can be described by the following equation:

$$V_r = (\text{Pump GPM} \times T)$$

where V_r is the required volume in gallons and T is 6 minutes for submersible pumps (if the pump runs for six minutes each time it starts, it cannot be required to start more than ten times in any given hour).

Using the operating flow of 52 gpm, the required volume in gallons for the Landmark North – West Retail Lift Station wet well is 312 gallons. Using a 6’ diameter wet well gives a necessary depth of 1.47 feet between the “First Pump On” and the “All Pumps Off” elevations.

Buoyancy Calculations

The SAWS Lift Station Guidelines (Rule J.2.C.9) require that a buoyancy check be completed for all wet wells. It must be shown that the weight of the wet well, pumps and concrete slabs is greater than the maximum buoyancy force that the system can encounter. The force of buoyancy (FB) can be described by the following equation:

**LANDMARK NORTH - WEST RETAIL – LIFT STATION
ENGINEERING REPORT**

$$F_B = W_G \pi (D/2)^2 d$$

Where:

W_G = specific weight of water (approximately 62.4 lbs/ft³)

D = diameter of the wet well, feet

d = empty depth of the wet well, feet.

The empty depth of the wet well can be determined by subtracting the “All Pumps Off” elevation from the top elevation of the wet well. This will give the maximum possible volume of empty wet well and therefore yields the largest possible buoyancy force that the system could be subject to.

The buoyancy force is 24,877 lb. The lift station is comprised of several components whose weight will counteract the buoyancy force. These components are the weight of the concrete slabs that constitute the top and bottom of the wet well; the weight of the fiberglass wet well, the weight of the stored sewage and the weight of the soil above the foundation of the wet well, etc.

Pump Cycle Time

The 2.5 Hp grinder pump will have a cycle time of 6 minutes. Based on calculations provided by Smith Pump Company, the 18” spacing between the Pump Off Float and Lead Pump Float the pump cycle will be 9.8 starts as a worst case.

Lift Station Security

The private lift station will be enclosed within a perimeter security fence. The 8’ tall fence will have an access gate for maintenance. The intruder resistant fencing will be constructed with a combination of wood and masonry to match the general architecture of the surrounding retail center. The lift station will have security lighting.

Signature, Seal and Date of the Texas Professional Engineer Below:



**Edwards Aquifer Recharge Zone
San Antonio**

PUMP CYCLE CALCULATOR



INPUT DATA

Wet Well Diameter (in)	36
Pump Down Distance (in)	18
Working Volume (gal)	79
Average Pump Flow (gpm)	52
Surcharge Volume (if applicable*)	0
Lift Station Inflow Rate (gpm)	5

	10	15	20	25	30	35	40	45	50	55
--	----	----	----	----	----	----	----	----	----	----

CALCULATED RESULTS @ ABOVE INFLOW GPM

Working Volume Fill Time (Storage Time) (min)	15.9	7.9	5.3	4.0	3.2	2.6	2.3	2.0	1.8	1.6	1.4
Pump Run Time without Inflow (min)	1.5	1.5	1.5	1.5	1.5	1.5	1.5	1.5	1.5	1.5	1.5
Pump Run Time with Inflow (min)	1.7	1.9	2.1	2.5	2.9	3.6	4.7	6.6	11.3	39.7	-26.4
Pump Run Time + Refill Time (Cycle Time) (min)	17.6	9.8	7.4	6.4	6.1	6.2	6.9	8.6	13.1	41.2	-25.0
Starts / HR with Inflow	3.4	6.1	8.1	9.3	9.8	9.6	8.7	7.0	4.6	1.5	-2.4

* If a surcharge volume is entered, it will be added to Pump Down Volume and included in all calculations.

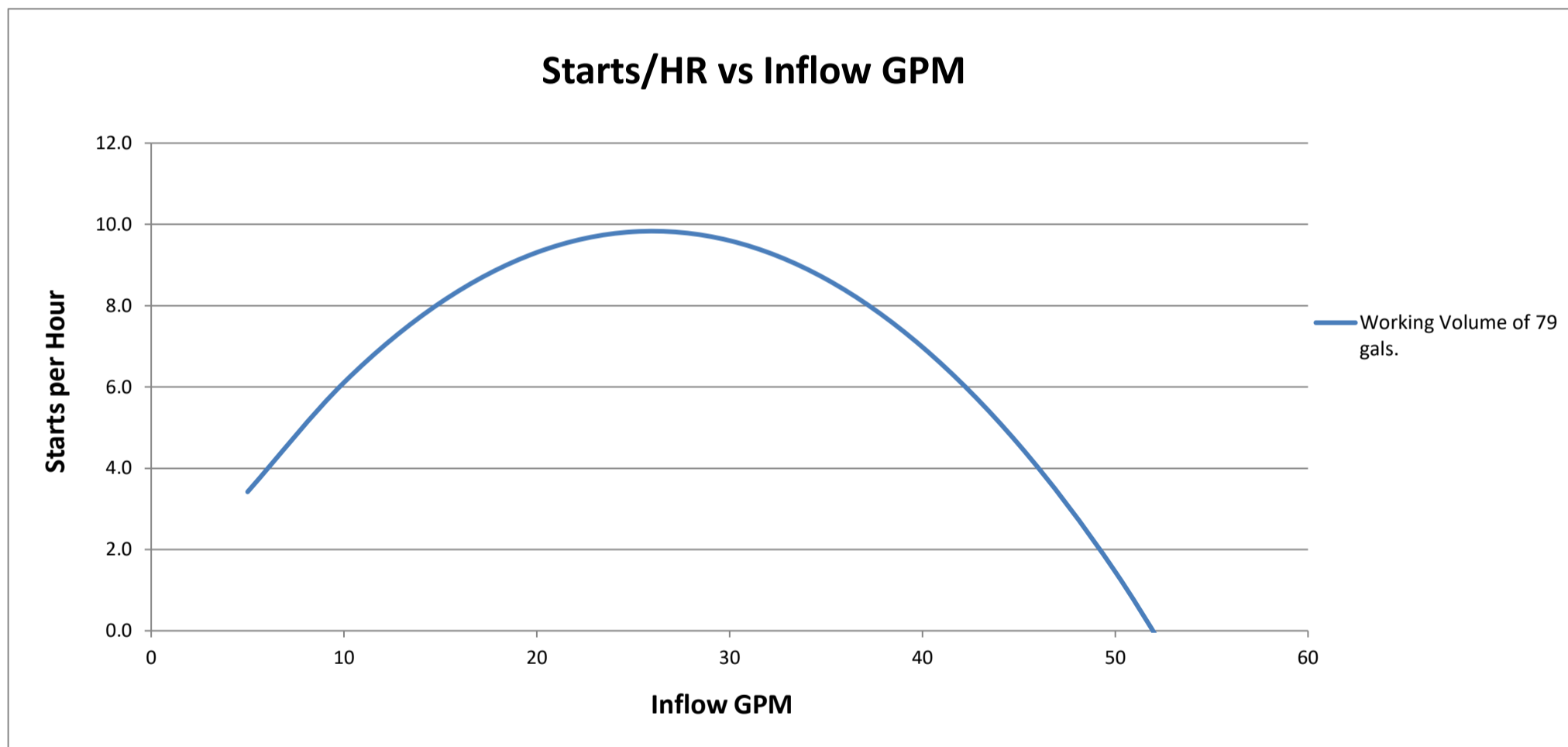

Conclusion:

If the OFF float and LEAD float are spaced 18 inches apart, the pump cycle will be 9.8 starts per hour at worst case inflow rate.

The submersible pump manufacturer will allow around 10 starts per hour maximum for a pump this size for proper heat dissipation.

Lift Station Basin and Float Setting Elevations

Edwards Aquifer Recharge Zone
San Antonio

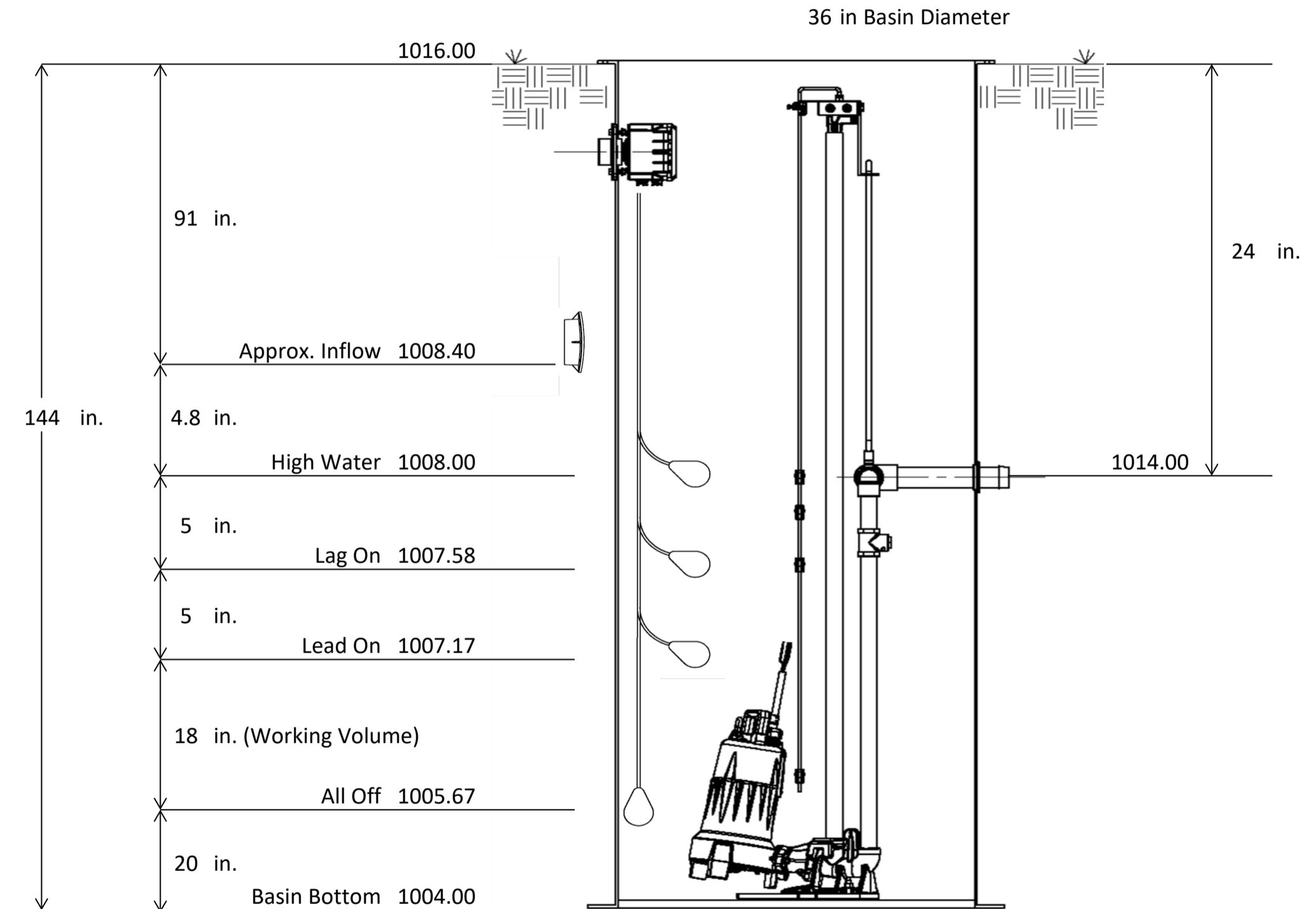

(This drawing is not to scale)

Liberty Pumps®

Engineered **Products**



LGV02-Series LGH02-Series Grinder

2.5_{hp}

Ordinary Location

60 Hz

Features

- Patented V-Slice® Cutter Technology
- High flow and High head models
- 1-1/4" Discharge
- Stainless steel impeller
- One-piece uni-body casting
- Quick-connect power cord
- External capacitor (requires panel)



Technical Data



Performance Curve



Dimensional Data



Specifications and Construction

Patent: See
www.LibertyPumps.com/LEP/patents



Proudly built in the USA with
US and global components



LGV High Volume

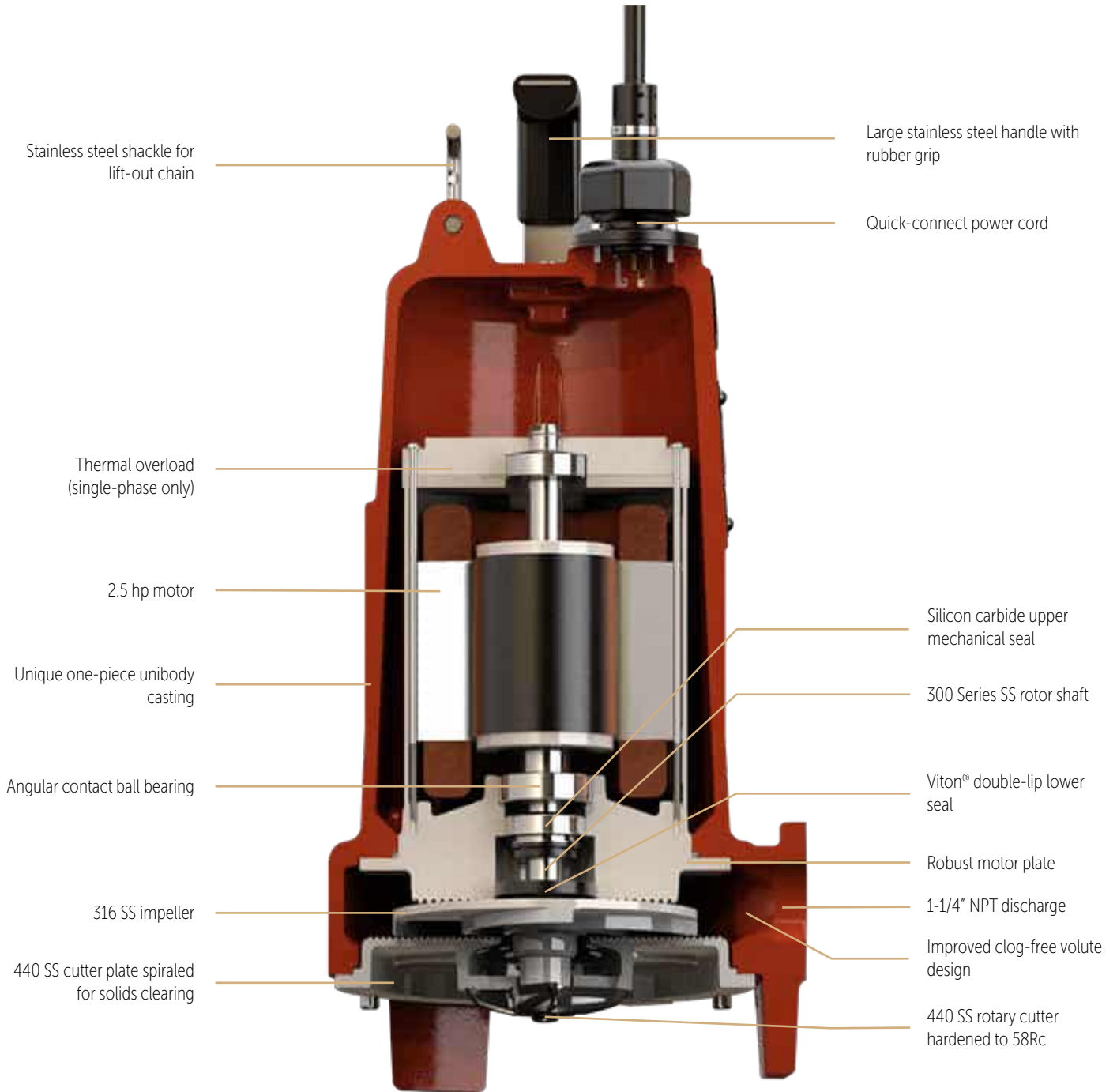

Patent: See
www.LibertyPumps.com/LEP/patents

LGH High Head

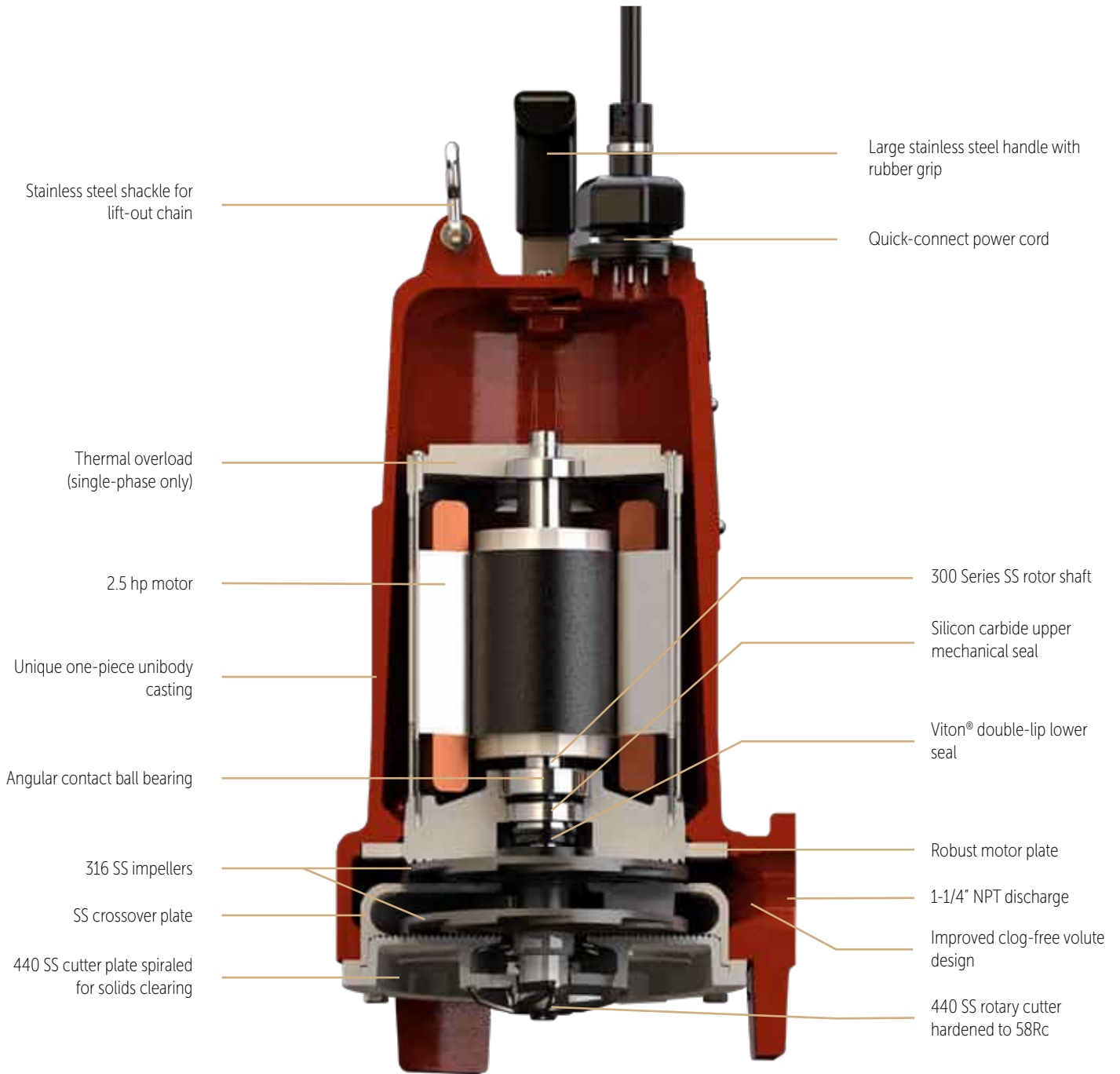

Patent: See
www.LibertyPumps.com/LEP/patents

Model Number	LGH028	LGH022	LGH023	LGH024	LGH025	LGV028	LGV022	LGV023	LGV024	LGV025
HP	2.5	2.5	2.5	2.5	2.5	2.5	2.5	2.5	2.5	2.5
Volts	200	230	200/230	460	575	200	230	200/230	460	575
Phase	1	1	3	3	3	1	1	3	3	3
Hz	60	60	60	60	60	60	60	60	60	60
RPM	3450	3450	3450	3450	3450	3450	3450	3450	3450	3450
FLA	20	20	13.7	6.9	5.5	18.5	17	12.5	6.5	5
SFA	20	20	13.7	6.9	5.5	18.5	17	12.5	6.5	5
LRA	71.2	70	59.2	27.3	24	66.1	70	59.2	27.3	24
Max kW Input	3.9	4	4.3	4.3	4.3	3.3	3.7	3.5	3.4	3.4
Service Factor	1	1	1	1	1	1	1	1	1	1
Power Factor	.99	.99	.84	.82	.84	.99	.99	.89	.77	.76
KVA Code	G	H	L	L	P	G	H	L	L	P
Std. Impeller Diameter (in)	5.86	5.86	5.86	5.86	5.86	5.95	5.95	5.95	5.95	5.95
Shut-Off Head (ft)	185	185	185	185	185	110	110	110	110	110
Power Cord Type & Diameter	12/4 SOOW	12/4 SOOW	12/4 SOOW	12/4 SOOW	12/4 SOOW	12/4 SOOW	12/4 SOOW	12/4 SOOW	12/4 SOOW	12/4 SOOW

Motor Insulation Class	1-phase - F 155°C 3-phase - B 130°C
Max Stator Temp	1-phase - 135°C 3-phase - 125°C
Impeller Type	Open
Impeller Material	316 Stainless Steel
Power Cord Length (Options)	25, 35, 50 ft
Quick-connect Cords	Standard
Upper Seal Material	Silicon Carbide/Silicon Carbide HNBR Elastomers
Lower Seal Material	Double Lip Seal Viton Elastomers
Max Water Temp for Continuous Duty	40°C
Min Fluid Level for Continuous Operation	Motor Housing Fully Submerged
Shaft Material	303 Stainless Steel
Fastener Material	Stainless Steel
O-Ring Elastomers	Buna-N

Upper Bearing	Radial Ball
Lower Bearing	Angular Contact Ball
Oil Type	ISO VG10 Turbine Oil
Max Submersion Depth	10 ft less than selected cord length (not to exceed 40 ft)
Discharge	1.25 in FNPT
Protective External Finish	Epoxy Powder Coat
Seal Fail Detection	No
Thermal Protection	1-phase - Direct Acting, 135°C 3-phase - none
Motor Enclosure Material	Class 25 Cast Iron
Volute Material	Class 25 Cast Iron
Cuts Per Minute	372,600
Cutter Material	440 Stainless Steel
Certifications	CSA Certified to CSA and UL® Standards CAN/CSA C22.2 No. 108.14 ANSI/UL 778 6th Ed

Note: Single-phase motors are capacitor type. Liberty Pumps control panel or capacitor kits are recommended for proper operation and warranty. Consult Factory for part numbers

Specifications are subject to change without notice.

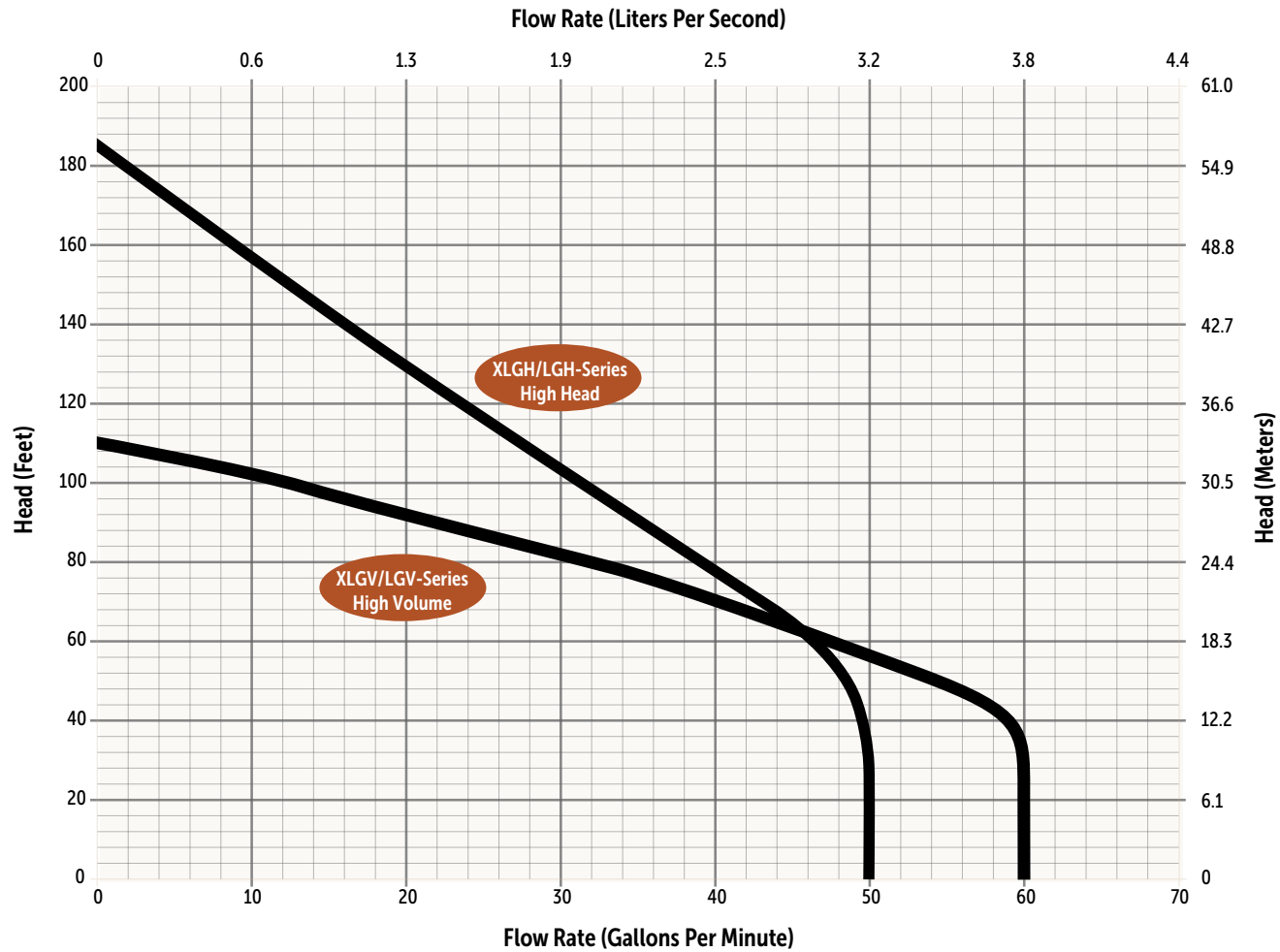

*Pumps must operate within the proper range shown on the performance chart. It is the responsibility of the end user to ensure this requirement is met. Pumps operating outside the recommended range are prone to damage, excessive vibration, cavitation, poor efficiency, and will exceed nameplate amperage.

Specifications are subject to change without notice.

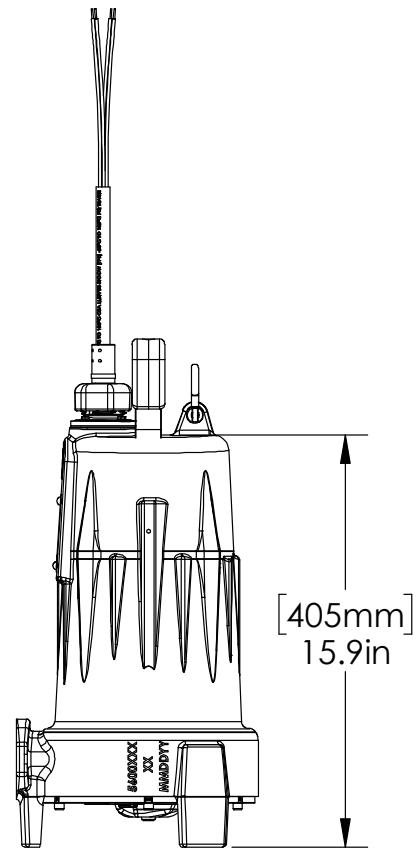
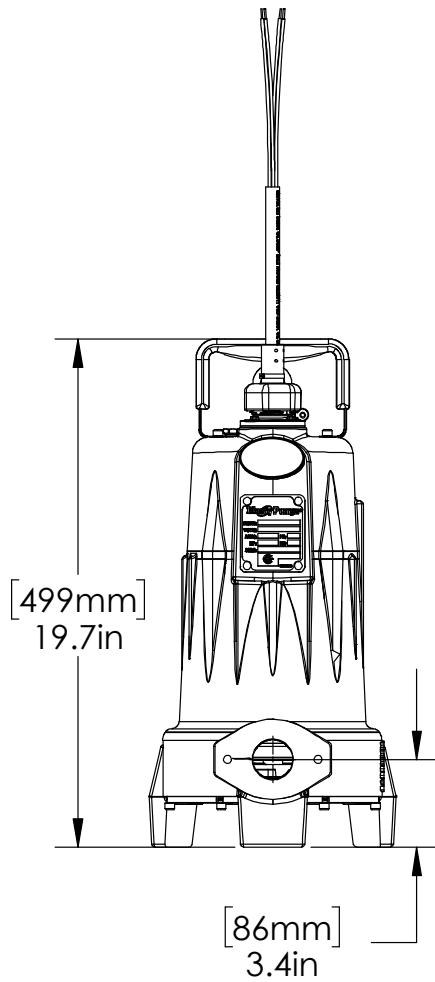
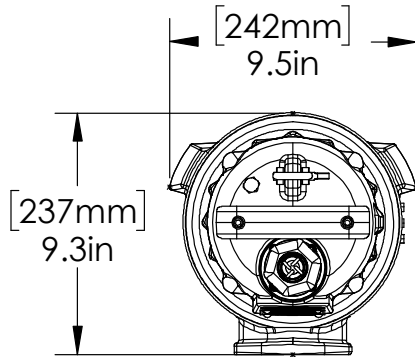

Specifications are subject to change without notice.



Standard Panel

STANDARD PANEL - SIMPLEX & DUPLEX

- Across-the-line magnetic contactor(s)
- Test/Auto switch(es)
- Terminal block
- Green pump run light(s)
- Alarm horn
- Red alarm indicator light or beacon
- Alarm silence and test switches
- Auxiliary contacts



GR20-Series

GR20-SERIES

- Single guide pipe design with auto-align feature
- Powder coated for corrosion resistance
- Heavy nitrile sealing grommet
- Includes: mating flange, upper rail support bracket, stainless steel bolts and sealing grommet
- All cast iron
- 1-1/4" guide pipe threads FNPT
- 1-1/4" discharge threads FNPT



G90-Series

G90-SERIES

- Fits 2.5 hp Omnivore® Series Grinders
- Provides vertical discharge for non-guide rail installations
- 1-1/4" female threaded outlet
- Heavy cast iron construction
- Powder coated for corrosion resistance
- Includes sealing grommet and stainless steel bolts

GENERAL

The contractor shall provide labor, material, equipment, and incidentals required to provide _____ (QTY) sewage grinder pumps as specified herein. The pump models covered in this specification are high head models LGH028, LGH022, LGH023, LGH024, LGH025 and high volume models LGV028, LGV022, LGV023, LGV024, LGV025 grinder pumps. The pump furnished for this application shall be model _____ as manufactured by Liberty Pumps.

OPERATING CONDITIONS

Each submersible pump shall be rated at 2.5 hp, _____ Volts, _____ phase, 60 Hz, 3450 RPM. The unit shall produce _____ GPM at _____ feet of total dynamic head.

The submersible pump shall be capable of handling residential and commercial sewage and grinding it to a fine slurry, enabling it to be pumped over long distances in pipelines as small as 2" in diameter. The LGH02-Series submersible pump shall have a shut-off head of 185 feet and a max flow of 50 GPM @ 10 feet of total dynamic head. The LGV02-Series submersible pump shall have a shut-off head of 110 feet and a max flow of 60 GPM @ 10 feet of total dynamic head.

CONSTRUCTION

Each centrifugal sewage grinder pump shall be equal to the Certified LGH02/LGV02-Series pumps as manufactured by Liberty Pumps, Bergen NY. The casting enclosing the motor shall be constructed of class 25 cast iron. The motor housing shall be oil-filled to dissipate heat. Air-filled motors shall not be considered equal since they do not properly dissipate heat from the motor. Mating parts shall be machined and sealed with a Buna-N O-ring. All fasteners exposed to the process fluid shall be stainless steel. The motor shall be protected on the top side with a sealed cast iron cord entry plate, which is potted to prevent water from entering through the cord. The motor shall be protected on the lower side with a dual seal arrangement. The first seal shall be a double lip seal molded in elastomeric rubber. The second (main) seal shall be a unitized hard face silicon carbide seal with stainless steel housings and spring. The upper and lower bearings shall be capable of handling all radial thrust loads. The lower bearing shall have the additional ability to handle the downward axial thrust produced by the impeller and cutters by design of angular contact roller races. The pump housing shall be of a concentric design thereby equalizing the pressure forces inside the housing that will extend the service life of the seals and bearings. Additionally, there shall be no cutwater in the housing volute in order to discourage the entrapment of flowing debris. The pump shall be furnished with stainless steel handle having a nitrile grip.

POWER AND CONTROL CORD

The submersible pump shall be supplied with 25, 35, or 50 feet of a multi-conductor cord of type SOOW. These type SOOW power cords carry a voltage rating of 600 V, a temperature rating of 90°C, have oil-resistant insulation, are water- and weather-resistant, UL listed, and CSA approved.

The power cord shall be sized for the rated full load amps of the pump for continuous duty in accordance with the NEC®.

Standard Quick-connect cord shall offer quick cord replacement without the need to send the entire pump to an authorized repair facility. This shall also allow for pump maintenance without disturbing electrical boxes or control panels.

MOTOR

The motor shall be oil-filled, Class F (1-phase)/Class B (3-phase) insulated, and rated for continuous duty. Since air-filled motors are not capable of dissipating heat efficiently, they shall not be considered equal.

1-phase pump motors shall be capacitor start/capacitor run and have an integral thermal overload switch in the windings for protecting the motor. 3-phase motors shall be used with an appropriate controller with integral overload protection. On all 1-phase models, the capacitor circuit and start relay shall be mounted in a correctly sized control panel.

1-phase motor(s) copper stator windings shall be insulated with moisture-resistant Class F insulation materials, rated for 155°C. The maximum continuous temperature of pumped liquids shall be 40°C. The winding operating temperature at rated horsepower and service factor shall be a maximum of 135°C @ 40°C ambient.

3-phase motor(s) copper stator windings shall be insulated with moisture-resistant Class B insulation materials, rated for 130°C. The maximum continuous temperature of pumped liquids shall be 40°C. The winding operating temperature at rated horsepower and service factor shall be a maximum of 125°C @ 40°C ambient.

BEARINGS AND SHAFT

The shaft shall be supported by two ball bearings. The top bearing shall be a single ball/race type bearing and the lower bearing shall be an angular contact ball bearing designed to handle the radial and axial forces incurred by pumping/grinding. Both bearings shall be permanently lubricated by the oil that fills the motor housing. Pump designs requiring scheduled bearing maintenance shall not be considered equal. Pumps with single row lower bearings or sleeve bearings shall not be considered equal. The bearing system shall be designed to enable proper cutter alignment from shutoff head to maximum load at 185 ft of TDH.

The motor shaft shall be made of 303 stainless steel. The shaft shall be designed to withstand the maximum torque and radial loads present during start-up and normal operation. Shafts of carbon steel or chrome-plated shafts shall not be considered equal.

SEALS

The pump shall have a dual seal arrangement consisting of a lower and upper seal to protect the motor from the pumping liquid. The lower seal shall be a rubber molded double lip seal with Viton elastomers, designed to exclude foreign material away from the main upper seal. The upper seal shall be a unitized silicon carbide hard face seal with stainless steel housings and spring. The motor plate/housing interface shall be sealed with a Buna-N O-ring.

CUTTER MECHANISM

The cutter and plate shall consist of hardened 440 stainless steel with a Rockwell C hardness of 58Rc. The stationary cutter plate shall have specially designed orifices through it, which enable the slurry to flow through the pump housing at an equalized pressure and velocity. The stationary cutter plate shall feature patented V-Slice® Cutter Technology. This superior cutting system consists of V shapes to maximize cutting action and arc shape exclusion slots to outwardly eject debris from under the rotary cutter. The rotary cutter shall have (4) blades and be designed with a recessed area behind the cutting edge to prevent the accumulation and binding of any material between rotary cutter and the stationary cutter plate. The cutter shall be capable of over 300,000 cuts per minute. The cutting system shall incorporate close tolerances for optimum performance. Ring or radial cutters, or those that grind on the outside circumference of shall not be considered equal.

IMPELLER

The impeller shall be 316 Stainless Steel. The impeller shall be keyed and bolted onto the motor shaft.

CONTROL PANEL

All LGH02/LGV02-Series pumps require a control panel. The control panel shall be equipped with circuit breakers and adjustable overload devices to protect against excess current or electrical problems. This device shall be sized appropriately for the pump model(s) being controlled.

The control panel for 1-phase models shall include a motor start circuit that automatically engages and disengages the start windings of the 1-phase motor. The motor start circuit shall consist of a properly sized relay which engages and disengages the motor start windings. A solid state start switch shall monitor start winding voltage and shall control the aforementioned relay. The start and run capacitors shall be properly sized per the motor specifications. A bleed resistor shall be used on the start capacitor to avoid unwanted voltage spikes during startup.

QUALITY CONTROL

The pump shall be manufactured in an ISO® 9001 certified facility. Manufactured in the USA with US and global components.

SUPPORT

The pump shall have cast iron support legs, enabling it to be a freestanding unit. The legs shall be high enough to allow solids and long stringy debris to enter the pump inlet.

PROTECTIVE FINISH

The exterior of the casting shall be protected with corrosion-resistant baked-on epoxy powder coat.

TESTING

The pump shall have a ground continuity check and undergo a hi-pot test for electrical integrity, moisture content, and insulation defects. The motor housing shall be pressurized, and an air leak decay test performed to ensure integrity of the assembled unit. The pump shall be run, voltage and current monitored, and checked for noise or other malfunction. Certified performance testing is available upon request.

APPLICATIONS

- Municipal Engineered Lift Stations
- Storm Water Removal
- Wastewater Transfer
- Industrial Wastewater
- Treatment Plants

MATERIAL FEATURES PUMP:

- Grinder - High Head or High Volume
- Discharge - Horizontal, 1.25" FNPT
- Seals - Dual, Upper - Silicon Carbide/Silicon Carbide with HNBR Elastomers; Lower - Double Lip Seal with Viton Elastomers
- Construction - Cast Iron ASTM A48, Class 25A, 25,000# Tensile Strength, Protected with a Corrosion-Resistant Baked-on Epoxy Powder Coating
- Hardware - Stainless Steel
- O-ring Seals - Buna-N
- Impeller - 316 Stainless Steel
- Cutter and Cutter Plate - Hardened 440 Stainless Steel
- Cuts per minute - 372,600
- Thermal Sensors (1-phase only)
- Optional:
 - Cable Length Options (feet) - 25, 35, 50



Engineered **Products**

MOTOR:

- 1-Phase - 200, 230 Volt, 3450 RPM
- 3-Phase - 200/230, 460, 575 Volt, 3450 RPM
- Oil-filled Motor Housing
- Continuous Duty Operation
- Bearings
 - Upper - Radial Ball
 - Lower - Angular Contact Ball

LIMITED WARRANTY

Liberty Pumps, Inc. warrants that pumps of its Engineered Product line are free from all factory defects in material and workmanship for a period of 18 months from the date of installation or 24 months from the date of manufacture, whichever occurs first, and provided that such products are used in compliance with their intended applications as set forth in the Liberty Engineered Products specifications and technical manuals. The date of installation shall be determined by a completed pump start-up report and warranty registration form.

A pump startup report, filled out by a qualified installer, is required for warranty to take effect. The report must be submitted within 30 days from the installation date and submitted through the Liberty Pumps website. During the warranty period, the manufacturer's obligation, and at its discretion, shall be limited to the repair or replacement of any parts found by the manufacturer to be defective, provided the product is returned freight prepaid to the manufacturer or its authorized service center, and provided that none of the following warranty-voiding characteristics are evident:

The manufacturer shall not be liable under this Warranty if the product has not been properly installed or maintained in accordance with the printed instructions provided; if it has been disassembled, modified, abused or tampered with; if the pump discharge has been reduced in size; if the pump has been used in water temperatures above those shown in the specifications; if the thermal overload(s) and seal moisture probe(s) have not been properly connected (where equipped); if the pump has been used in water containing sand, lime, cement, gravel or other abrasives; if the product has been used to pump chemicals or hydrocarbons; if the product has been moved from its original installation location, or if the label bearing the serial and code number has been removed.

Liberty Pumps, Inc. shall not be liable for any loss, damage or expenses resulting from installation or use of its products, or for consequential damages, including field labor costs, travel expenses, rental equipment, costs of removal, reinstallation or transportation to and from the factory or an authorized Liberty Pumps repair facility.

There is no other express warranty. All implied warranties, including those of merchantability and fitness for a particular purpose, are limited to 18 months from the date of installation or 24 months from the manufacturing date. This Warranty contains the exclusive remedy of the purchaser, and, where permitted, liability for consequential or incidental damages under any and all warranties are excluded.

Specifications are subject to change without notice.

Landmark North Restaurant Pad
 Lift Station Design
 MBC Project Number 30371/0976

Wet Well Sizing

Ground Elevation	1016	ft			PWWF	Peak inflow	13.71	gpm
Sewer Into Well	1008.4	ft				Response time	1.5	hours
Emergency Volume	375.3	gal				Pump Cycle	6	min
Working Volume	420	gal				Flow out	70	gpm
Wet Depth	0.5	ft			ADWF	Avg Daily Weather Flow	4.17	gpm
Well Diameter	6	5	4	3				
Emergency Depth	1.78	2.56	3.99	7.10				
Working Depth	1.99	2.86	4.47	7.95				
TOTAL DEPTH	10.10	11.00	12.60	16.10				
INVERT OF WELL	1005.90	1005.00	1003.40	999.90				

LIFT STATION DESIGN SEWER DEMAND CONTRIBUTION

Population Calculations

Lift Station #1 8570 sf of restaurant space
 0.035 seats per sf of restaurant space
 300 number of seats

Total Number of Seats	300
------------------------------	------------

SAWS Design Criteria

1 EDU = 200 Gal / Day
 1 seat = 20 Gal / Day
 Number of EDUs = 30

Development Size 7.9 Acres
 Inflow and Infiltration = 600 Gal/ Acre*Day

Calculations

Total Avg Dry Weather Flow (F) - 6,000 Gal/day or 4.17 gpm

Peaking Factor (Mp =) 2.50 Unitless

Min. Flow Factor (Mm =) 0.11 Unitless

$$Mm = 0.2 * (0.0144 * F)^{0.198}$$

Minimum Dry Weather Flow - 687.47 Gal/day or 0.48 gpm

Peak Dry Weather Flow - 15,000 Gal/day 10.42 gpm

I&I Contribution - 4,740 Gals/Day or 3.29 gpm

Total Peak Wet Weather Flow - 19,740 Gal/ Day or 13.71 gpm

70 gpm - Total pump flow

Lift Station Firm Capacity - 0.020 MGD

Selected Force Main Diameter - 3.0 Inches

Force Main Velocity Check - 3.18 Feet/ Sec

Meets SAWS criteria of
 3-6 fps at ultimate development

LIFT STATION DESIGN WET WELL SIZING

Lift Station Size Design Criteria

Pump HP From Manufacture:	2.5 HP		
Cycle Time	6 Minutes		
Ground Elevation @ Proposed Wetwell:	1016.00	Feet	
Water Elevation w/in Wetwell:	999.90	Feet	Pump Off should be 6-inch above pump casing
Elevation of Floor of Proposed Wetwell:	998.40	Feet	
Flow Line of Gravity Line	1008.40		
High Level Alarm	1007.90	Feet	1-ft higher than highest pump on, 1-ft lower than flow line
Low Level Alarm	999.40	Feet	
Minimum Vol Between Pump On/ Off	105.00	Gallons	14.04 cu.ft.
Lead Pump On (Pump 1) =	1,003.40		
Pump Off (Pump 1 off) =	1,001.90		
Elev. Change =	1.50	ft	Pump On/Pump Of Distance
Wet Well Dia. =	6.00	ft	
Wet Well Usable Volume =	42.41	ft ³	317.3 Gallons Volume is Good
Retention Time (Min 20 Minutes)	120.00	minutes	(Longest outage period assume Peak flow)
Retention Storage Required =	500	Gallons	@ 4.17 gpm (peak flow)
Storage between lead/lag =	183	Gallons	(Retention Storage-Minimum Vol between lead/lag)
Second Pump On	1,007.40	ft	
Total Storage	155.51	ft ³	1,163.4 Gallons Volume is Good
Total Effective Storage	183.69	ft ³	1,374.2 Gallons

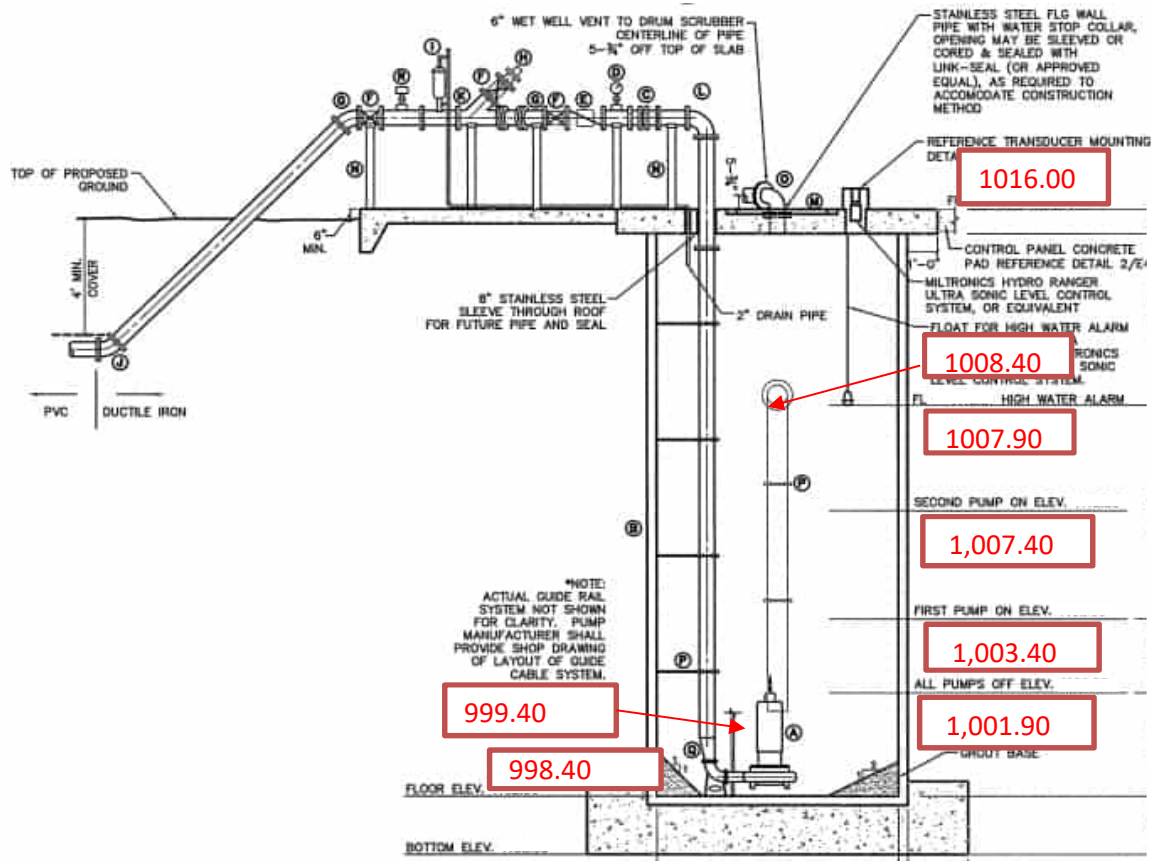

LIFT STATION DESIGN WET WELL SIZING

Lift Station Peak Flow (Pump) = 70.00 gpm

Lift Station Detention Time Calculations

MAX. WET WEATHER	19,740.00 Gal/day	or	13.71 gpm
Time to fill Wet Well (t_f) =	23.1 Min		
Time to empty Wet Well (t_e) =	5.6 Min		
Total Detention Time (T_d) =	28.78 Min		
MAX. DRY WEATHER	15,000.00 Gal/day	or	10.42 gpm
Time to fill Wet Well (t_f) =	30.459 Min		
Time to empty Wet Well (t_e) =	5.325 Min		
Total Detention Time (T_d) =	35.78 Min		
AVG. DRY WEATHER	6,000.00 Gal/day	or	4.17 gpm
Time to fill Wet Well (t_f) =	76.147 Min		
Time to empty Wet Well (t_e) =	4.819 Min		
Total Detention Time (T_d) =	80.97 Min		
MIN. DRY WEATHER	687.47 Gal/day	or	0.48 gpm
Time to fill Wet Well (t_f) =	664.585 Min		
Time to empty Wet Well (t_e) =	4.564 Min		
Total Detention Time (T_d) =	669.15 Min		

Force Main Detention Time Calculations

Length of Force Main =	350.00 ft
Velocity in Force Main (V_{fm}) =	3.18 feet/sec
Volume of Wet Well =	317.28 gal
Pump Cycle Time (PCT) =	304.59 min

$$T_{flush} = (t_f + t_e) * \frac{FMlength}{(PCT/2) * V_{fm} * (60s/min)}$$

T_{flush} = Time to flush Force Main - 0.98 min

Total Detention Time 670.12 Per SAWS Code - No Odor Control is Required.

LIFT STATION DESIGN NET POSITIVE SUCTION HEAD SUCTION SPECIFIC SPEED

Net Positive Suction Head Comparison (Pump - Available)

NPSH from Pump Manufacture	0 feet	
Elevation of Lift Station	1016.00	Altitude in feet
Barometric Pressure (P _B =)	28.86	
Static Suction Head in Feet (H _S =)	1	
Vapor Pressure (P _V =)	0.2563	
Friction Loss in Feet (H _{FS} =)	0.5	
NPSH _A = P _B +H _S -P _V -H _{FS}	29.1037	
NPSH _A - NPSH _{PUMP} =	29.1037	NPSH _A Should be greater than NPSH _{PUMP} =

Suction Specific Speed

$$SSS = \frac{RPM * PUMP^{0.5}}{NPSH^{0.75}}$$

Shaft Rotations	1750 RPMs	
Suction Specific Speed (SSS=)	1168.5 RPMs	(Maintain below 9000)

Stiffness Ration

Distance from Impeller (L=)	1 inches	
Diameter of Shaft (D=)	1 inches	
Stiffness Ration (SR =)	1	The stiffness shall not exceed 60.

$$S_R = \frac{L^3}{D^4}$$

LIFT STATION DESIGNS ENERGY CALCULATIONS

<u>Water Horsepower</u>	<u>Theoretical</u>	<u>Pump Manufacture</u>
Pump Flow (Q=)	70 gpm	$P = \frac{(Q)(h)(8.34 \frac{lb}{gal})}{33,000 ft - lb min/hp}$
Head (h =)	21.7 ft	
Horsepower (P=)	0.38 HP	

<u>Brake Horsepower</u>		
Pump efficient	0.391	0.504
Break Horsepower (Bhp =)	0.98	4.96

<u>Electrical Horsepower</u>		
Motor Efficiency	0.85	0.79
Electrical (Ehp =)	1.15 Ehp	6.28 Ehp

<u>Power Consumption</u>		
Power Required in Kilowatts =	0.860591558 Kilowatts	4.684046614
Pump 1 Run Times	0.71 Hours	0.71 Hours
Pump 2 Run Times	0.71 Hours	0.71 Hours
Daily Power Consumption	1.23 kWh Per Day	6.69 kWh Per Day

<u>Estimate Cost for Power Consumption</u>		
Cost Per Kilowat	\$ 0.06	\$ 0.06
Time in Service	22436.85 days	122119.79
Cost of power over the life of the station	\$ 1,346.21	\$ 7,327.19 kWh Per Day

LIFT STATION DESIGN WATER HAMMER/ SURGE ANALYSIS

Surge Analysis

Pump Flow = 70.00 gpm
Velocity in Pipe (v) = 3.18 fps
Operating Pressure = 11.17 psi

Pipe Material = C-900 PVC
Length of Pipe = 350.00 feet
Dia. Of Pipe = 4 in
Pipe A Thickness = 0.25 in

Young's Modulus of PVC (E) = 400000 psi
Bulk Modulus (Y) = 300000 psi
Spec. Weight of Water (w) = 62.4 psf

Find pressure wave velocity (a):

$$a = 12 \div \left\{ \frac{w}{g} \left(\frac{1}{k} + \frac{d}{E * t} \right) \right\}^{0.5}$$

a = 1310 fps for PVC

Find max surge pressure (P):

$$P = \frac{a * v}{2.31 * g} + \text{Operating Pressure}$$

P = 67.11 psi for PVC (pressure rated for 315 psi)

LIFT STATION DESIGN TOTAL DYNAMIC DESIGN

Ground Elevation of Existing Force Main Outfall Manhole:	1022.82	ft
Depth to Outfall Manhole Flowline (ft.):	7.39	ft
Man Hole Flowline Elevation:	1015.43	ft
Additional Head	0	
Static Head + Additional Head (ft.):	17.03	ft

Friction Head

Proposed Force Main: A" Diameter PVC Force Main		
Pipe Diameter (in.):	3	
Length of Force Main from Tie-In Point to Outfall (ft.):	350	
"C" Value:	100	140

Proposed Station Piping		
Pipe Diameter (in.):	3	
Length of Station Piping from Proposed Pumps to Proposed Force Main (ft.):	36	
"C" Value:	100	140

<u>Minor Losses</u>	# of Fittings (One Pump in Service)	# of Fittings	# of Fittings/Pump	# of Fittings/Force Main	Loss Coeff.
Lift Station					
Discharge Elbow Pump (4"):			1		0.9
90 Degree Bend out of Wetwell (4"):			2		0.9
Swing Check Valve (4"):			1		2.3
Tees at Header (4" x 4"):			0		1.8
Plug Valve (4"):			3		0.19
Force Main					
90 Degree Bend	1			1	0.9
45 Degree Bend	1			1	0.37
22.5 Degree Bend	0			0	0.15
11.25 Degree Bend	0			0	0.1
Gate Valve (Fully Open)	1			1	0.19
Discharge at Manhole:	1			1	1

**LIFT STATION DESIGN
 TOTAL DYNAMIC DESIGN**

Losses

Note: Number of Bends in Force Main are approximate

C = 100 for Station Piping, C = 100 for Proposed A" Force Main

Average Flow = 4 gpm		Peak Wet Flow = 14 gpm		Flow	Minor	
Flow (GPM)	Static Head (ft.)	Friction Head (ft.)	Velocity (fps)		Losses (ft.)	T.D.H. (ft.)
0	17.03	0	0		0	17.03
20	17.03	1.0	0.9		0.1	18.08
40	17.03	3.5	1.8		0.3	20.84
60	17.03	7.5	2.7		0.6	25.13
80	17.03	12.7	3.6	FLOW	1.1	30.86
100	17.03	19.2	4.5		1.8	37.99
120	17.03	26.9	5.4		2.6	46.47
140	17.03	35.7	6.4		3.5	56.27
160	17.03	45.8	7.3		4.6	67.36
180	17.03	56.9	8.2		5.8	79.71
200	17.03	69.2	9.1		7.1	93.31
220	17.03	82.5	10.0		8.6	108.14
240	17.03	96.9	10.9		10.3	124.19
260	17.03	112.4	11.8		12.0	141.43
280	17.03	128.9	12.7		14.0	159.87

C = 140 for Station Piping, C = 140 for Proposed A" Force Main

Average Flow = 4 gpm		Peak Wet Flow = 14 gpm		Flow	Minor	
Flow (GPM)	Static Head (ft.)	Friction Head (ft.)	Velocity (fps)		Losses (ft.)	T.D.H. (ft.)
0	17.03	0	0		0	17.03
20	17.03	0.5	0.9		0.1	17.63
40	17.03	1.9	1.8		0.3	19.20
60	17.03	4.0	2.7		0.6	21.67
80	17.03	6.8	3.6	FLOW	1.1	24.98
100	17.03	10.3	4.5		1.8	29.11
120	17.03	14.4	5.4		2.6	34.02
140	17.03	19.2	6.4		3.5	39.70
160	17.03	24.6	7.3		4.6	46.15
180	17.03	30.5	8.2		5.8	53.34
200	17.03	37.1	9.1		7.1	61.27
220	17.03	44.3	10.0		8.6	69.92
240	17.03	52.0	10.9		10.3	79.29
260	17.03	60.3	11.8		12.0	89.37
280	17.03	69.2	12.7		14.0	100.15
300	17.03	78.6	13.6		16.0	111.63

LIFT STATION DESIGN ODOR CONTROL

Hydrogen Sulfide Production

Initial Sulfide Production

Longest Stretch of Gravity line	230 LF	
Diameter of Gravity Line	6 inches	
Average Velocity	3 fps	
Anticipate BOD ₅	250 mg/l	Source Metcalf & Eddy, 4th Edition
Anticipate Initial Sulfide Concentration	0.06 mg/l	

Force Main Retention Time

Force Main Length	350 LF	350
Average Flow	0.006 MGD	0.18
Force Main Diameter	3 inches	3
Force Main Retention Time	30.827 min	1.02757

Sulfide Production

Temperature Avg Summer High	36 Celsius	Source Weather Channel
Temperature Avg. Winter Low	5 Celsius	Source Weather Channel

Effective BOD @ Summer High=	738.041 mg/l
Effective BOD @ Winter Low=	90.6115 mg/l

Sulfide (Summer High)	7.87 mg/l	or	0.3937 Pounds per Day
Sulfide (Winter Low)	1.02 mg/l	or	0.05081 Pounds per Day

Ferrous Sulfate Production

Assume Pencco's Ferrous Sulfate:PH>4

Dosage guidelines per Manufacture is 1 lb of H₂S requires 3.2 gallons of Ferrous Sulfate solution

Reducton of Sulfide Concentration to	0.5 mg/l	will produce the following revised Sulfide concentrations
Summer Production of sulfide	7.37 mg/l	or 0.36868 Pounds per Day
Winter Production of sulfide	0.52 mg/l	or 0.02579 Pounds per Day

Per Manufactures recommendation, the following Ferrous Sulfate is required for each season

Summer Day	1.17979 gallons per day	Meter Pump Size	0.04916 Gallons Per Hours
Winter Day	0.08254 gallons per day	Meter Pump Size	0.00344 Gallons Per Hours

Storage Time	90 Days	
Assume 60 Day Storage volume	106.181 Gallons	
Mini Bulk Tanks	500 Gallons Assume Norwesco Storage Containers with stand	
Diameter	48 in Polyethylene Cone Stand	32 in
Height	73 in Fill Opening	16 in
	Drain	2 in
Part No.	40150	

Containment Storage Required	66.84 ft ³
Inside Length	5
Inside Width	5
Height	2
Volume - Minus Tank Footprint	24.88 ft ³

Landmark North Restaurant Pad Liftstation System Curve 4" C -100

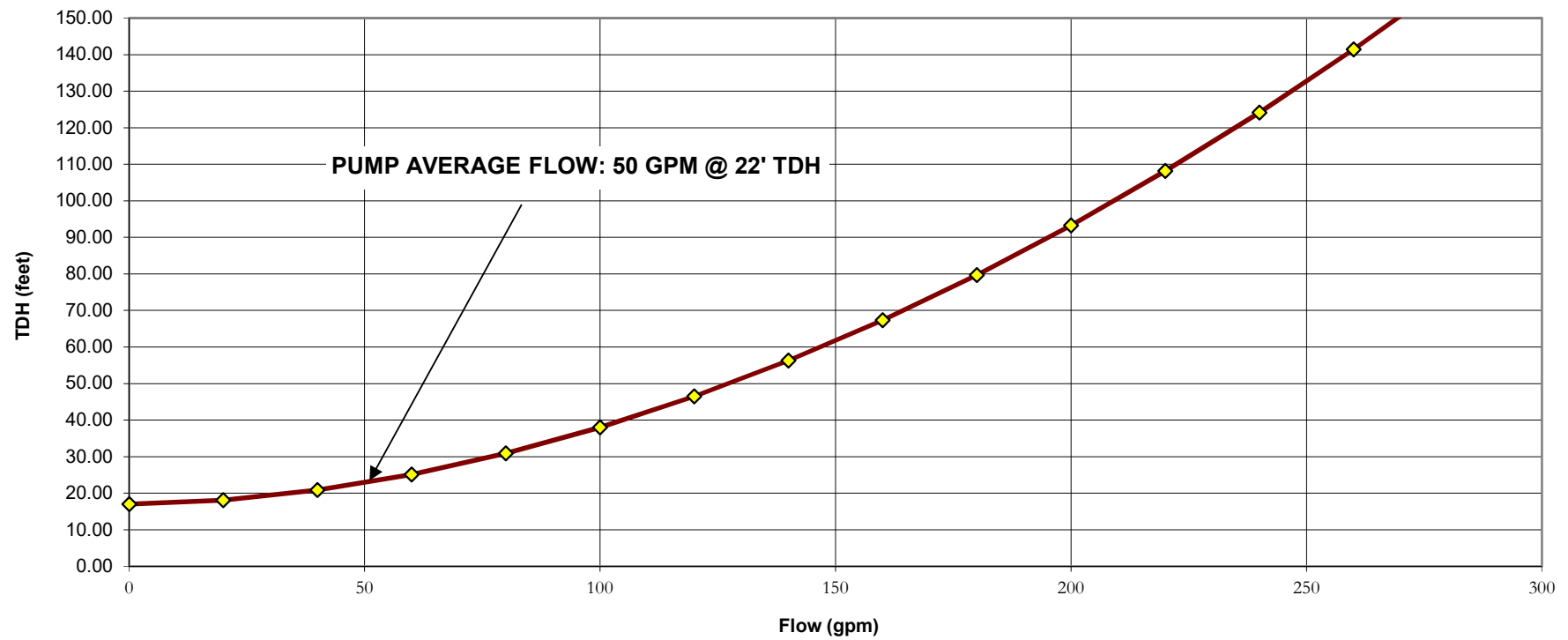

Landmark North Restaurant Pad Liftstation System Curve 4" C -140

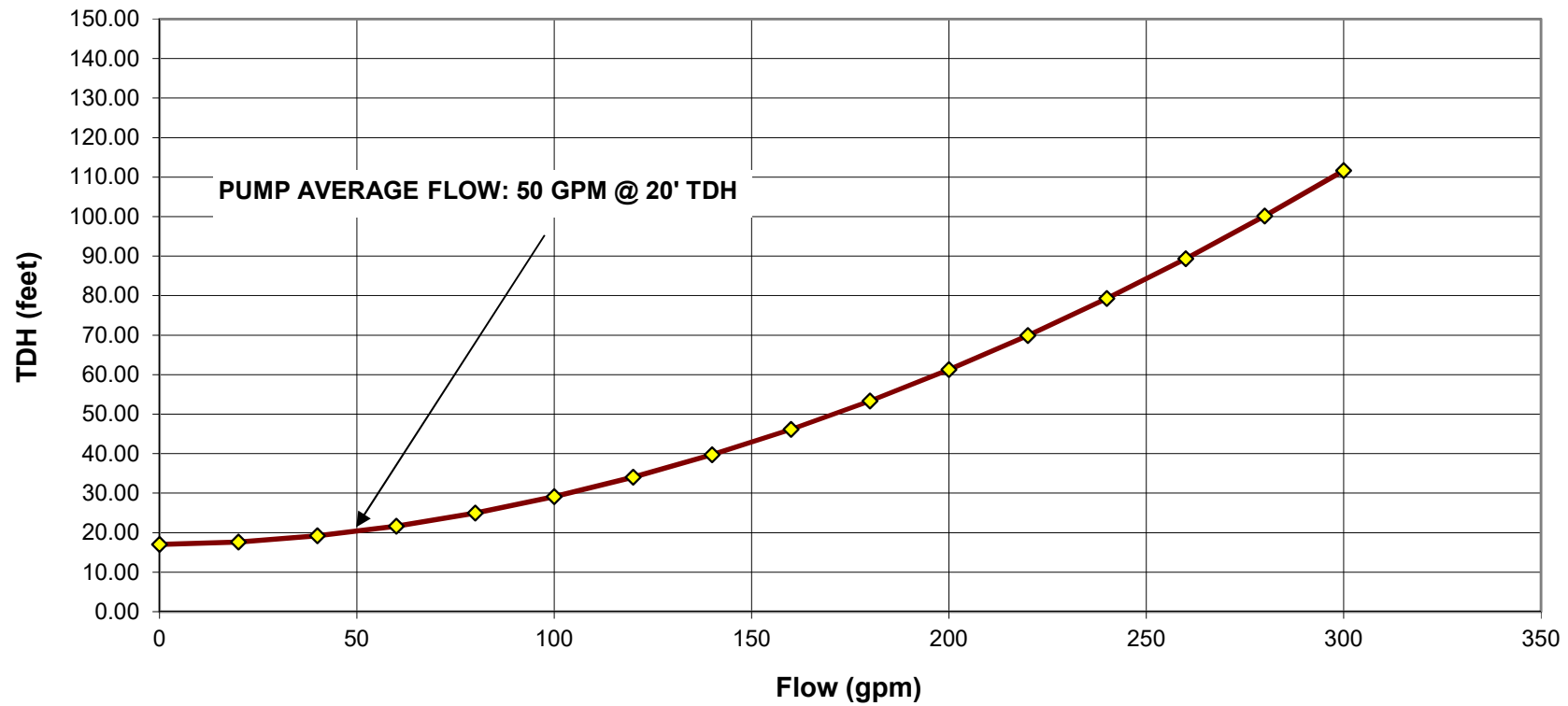

LIFT STATION DESIGN BOUYANCY CALCULATIONS WET WELL

Given

Diameter of Wet Well = 6.00 Feet
Diameter of concrete Base 8.00 Feet

Assume empty wet well weight with no liquids, pump, piping or other appurtenances adding to the weight

Forces Down must exceed Forces Up
Factor of Safety 2.00

Forces Down Weight of Soil Acting on Concrete Base + Weight of Concrete Base
Assume the unit weight of concrete is 150 pcf and the unit weight of submerged concrete is 87.6 pcf

Weight of Concrete 150 lbs/cuft
Weight of Concrete Submerged 87.6 lbs/cuft
Wt of Concrete (submerged) 8802.05 lbs

Unit Weight of Soil (DRY) 99 lbs/cuft
Unit Weight of Soil (sat) 130.00 lbs/cuft
Wt of Soil acting on Concrete Base 2857.40 lbs

Forces Up	Area of Wet Well* Unit weight of water :	4702.464 Lbs Up
Total Forces Down =	11659.45 lbs Down	

NO ADDITIONAL ANTI-FLOTATION DEVICES NEEDED

**LIFT STATION DESIGN
BOUYANCY CALCULATIONS
PIPE**

	FORCES DOWN											FORCES UP		ANALYSIS 1		ANALYSIS 2						
	Ws						Wp			Wc		WE	FS	CONDITION 1 - NO FILL		CONDITION 2 - FILL						
	OUTSIDE DIA. (FEET)	UNIT WT. SOIL DRY (PCF)	UNIT WT. SOIL SAT. (PCF)	HT. OF WATER ABOVE PIPE (FEET)	HT. OF SOIL ABOVE PIPE (FEET)	Ws (LBS/ FT)	SDR	LENGTH (FEET)	WT. OF PIPE PER L.F. Wp (LBS/ FT)	UNIT WT. OF W.W. (PCF)	Wc (LBS/ FT)	CONCRETE ENCASEMENT NEEDED (PCF)	FACTOR OF SAFETY	UNIT WT. OF WATER (PCF)	Fup	FDN	FUP	FDN	FUP			
4-FORCE MAIN	0.35	99	130	2	3	48.38	14	14	1.4	1.4	62.4	21.78	NONE	2	62.4	6.05	23.18	>	12.09	71.57	>	12.09
	0.35	99	130	2.5	4	60.26	14	14	1.4	1.4	62.4	21.78	NONE	2	62.4	6.05	23.18	>	12.09	83.44	>	12.09
	0.35	99	130	3	5	72.13	14	14	1.4	1.4	62.4	21.78	NONE	2	62.4	6.05	23.18	>	12.09	95.31	>	12.09
	0.35	99	130	3.5	6	84.00	14	14	1.4	1.4	62.4	21.78	NONE	2	62.4	6.05	23.18	>	12.09	107.18	>	12.09
	0.35	99	130	4	7	95.87	14	14	1.4	1.4	62.4	21.78	NONE	2	62.4	6.05	23.18	>	12.09	119.05	>	12.09
	0.35	99	130	4.5	8	107.75	14	14	1.4	1.4	62.4	21.78	NONE	2	62.4	6.05	23.18	>	12.09	130.93	>	12.09
	0.35	99	130	5	9	119.62	14	14	1.4	1.4	62.4	21.78	NONE	2	62.4	6.05	23.18	>	12.09	142.80	>	12.09
	0.35	99	130	6	10	143.36	14	14	1.4	1.4	62.4	21.78	NONE	2	62.4	6.05	23.18	>	12.09	166.54	>	12.09
6-INCH PVC GRAVITY PROPOSED	0.52	99	130	3	3	108.03	26	14	3.11	3.11	62.4	21.78	NONE	2	62.4	13.40	24.89	<	26.80	132.92	>	26.80
	0.52	99	130	4	4	143.38	26	14	3.11	3.11	62.4	21.78	NONE	2	62.4	13.40	24.89	<	26.80	168.27	>	26.80
	0.52	99	130	5	5	178.73	26	14	3.11	3.11	62.4	21.78	NONE	2	62.4	13.40	24.89	<	26.80	203.62	>	26.80
	0.52	99	130	6	6	214.08	26	14	3.11	3.11	62.4	21.78	NONE	2	62.4	13.40	24.89	<	26.80	238.97	>	26.80
	0.52	99	130	7	7	249.43	26	14	3.11	3.11	62.4	21.78	NONE	2	62.4	13.40	24.89	<	26.80	274.32	>	26.80
	0.52	99	130	8	8	284.78	26	14	3.11	3.11	62.4	21.78	NONE	2	62.4	13.40	24.89	<	26.80	309.67	>	26.80
	0.52	99	130	9	9	320.13	26	14	3.11	3.11	62.4	21.78	NONE	2	62.4	13.40	24.89	<	26.80	345.02	>	26.80
	0.52	99	130	10	10	355.48	26	14	3.11	3.11	62.4	21.78	NONE	2	62.4	13.40	24.89	<	26.80	380.37	>	26.80
8-INCH PVC GRAVITY PROPOSED	1.03	99	130	2	1.5	147.58	26	14	5.63	5.63	62.4	21.78	NONE	2	62.4	52.41	27.41	<	104.83	174.99	>	104.83
	1.03	99	130	2.1	2	154.57	26	14	5.63	5.63	62.4	21.78	NONE	2	62.4	52.41	27.41	<	104.83	181.98	>	104.83
	1.03	99	130	2.2	2.5	161.56	26	14	5.63	5.63	62.4	21.78	NONE	2	62.4	52.41	27.41	<	104.83	188.97	>	104.83
	1.03	99	130	2.3	3	168.55	26	14	5.63	5.63	62.4	21.78	NONE	2	62.4	52.41	27.41	<	104.83	195.96	>	104.83
	1.03	99	130	2.4	3.5	175.54	26	14	5.63	5.63	62.4	21.78	NONE	2	62.4	52.41	27.41	<	104.83	202.95	>	104.83
	1.03	99	130	2.5	4	182.53	26	14	5.63	5.63	62.4	21.78	NONE	2	62.4	52.41	27.41	<	104.83	209.94	>	104.83
	1.03	99	130	3	4.5	217.49	26	14	5.63	5.63	62.4	21.78	NONE	2	62.4	52.41	27.41	<	104.83	244.90	>	104.83
	1.03	99	130	3.5	5	252.44	26	14	5.63	5.63	62.4	21.78	NONE	2	62.4	52.41	27.41	<	104.83	279.85	>	104.83
1.03	99	130	4	6	287.40	26	14	5.63	5.63	62.4	21.78	NONE	2	62.4	52.41	27.41	<	104.83	314.81	>	104.83	

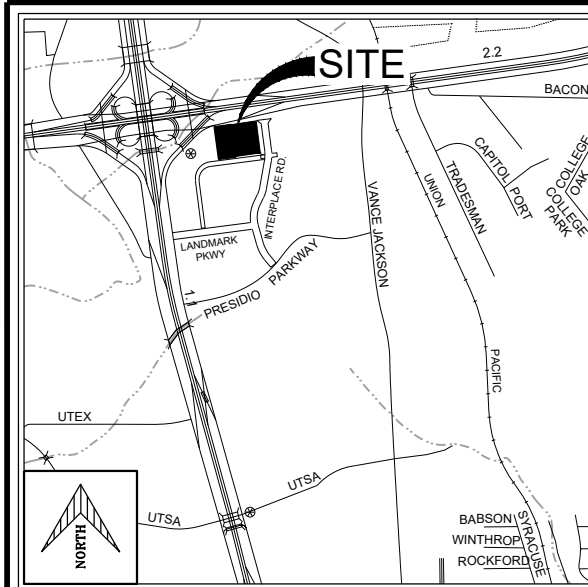

NOTE: REFERENCE GENERAL NOTES ON SHEET C02.00 PRIOR TO BID AND CONSTRUCTION

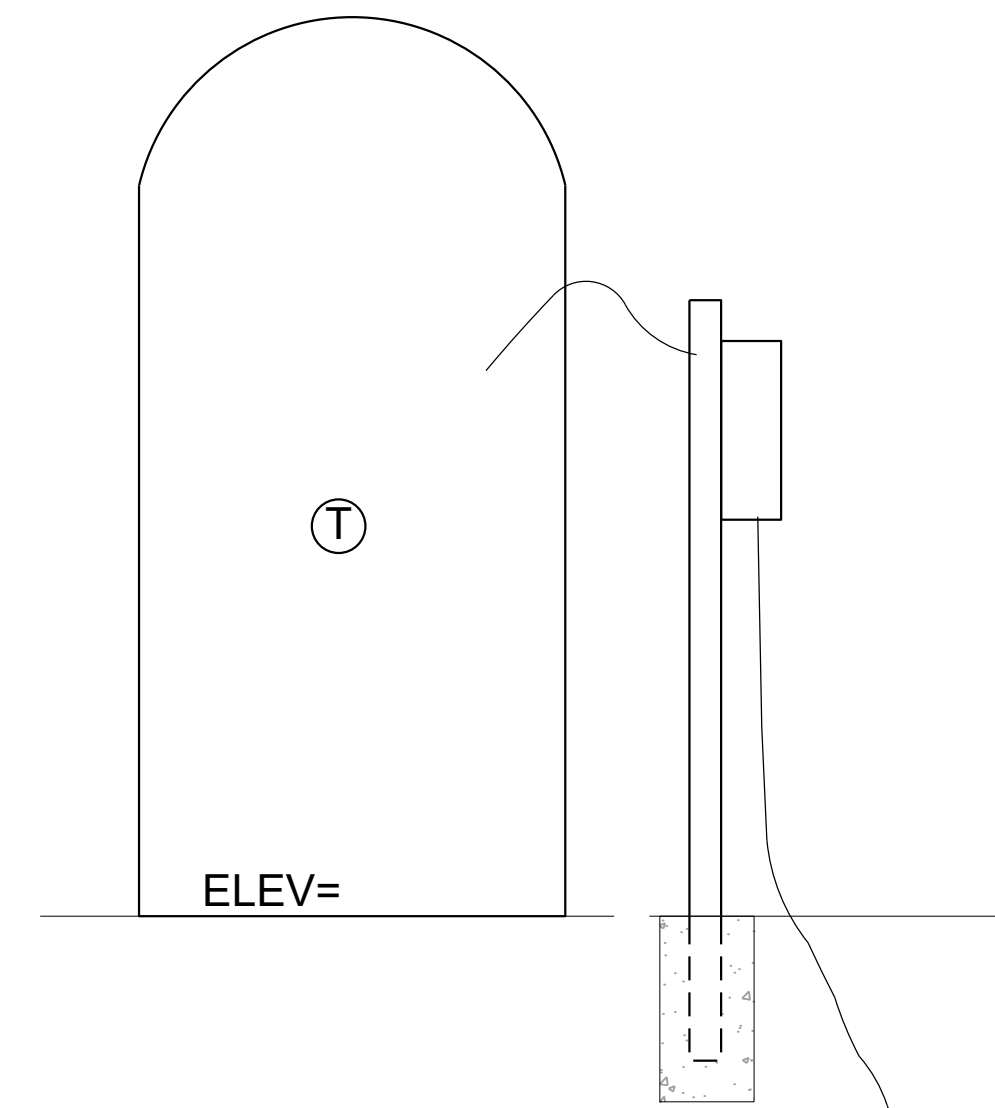
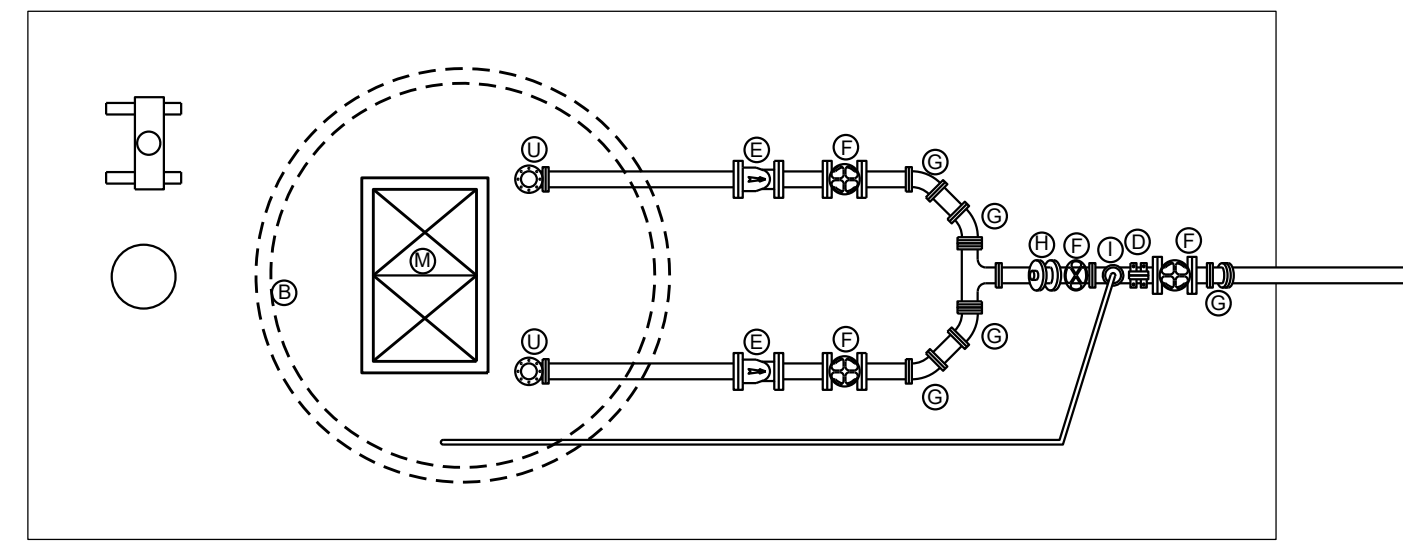

ODOR CONTROL UNIT
(FOR REFERENCE ONLY)

EQUIPMENT/FITTING LIST

MARK	DESCRIPTION	QUANTITY
A	SUBMERSIBLE PUMP W/ SEALING FLANGE ADAPTER AND STAINLESS STEEL LIFTING CHAINS	2
B	6' DIA. FIBERGLASS WETWELL, REF SPECIFICATIONS	1
C	4" RESTRAINED MECHANICAL JOINT COUPLING	3
D	PRESSURE GAUGE W/ RANGE OF 0-200 PSI (SHALL BE MOUNTED ON A BALL VALVE FOR ISOLATION)	2
E	4" SWING CHECK VALVE WITH EXTERNAL ARM	3
F	4" GATE VALVE	6
G	4" 45° BEND	6
H	4" EMERGENCY BY-PASS W/MALE QUICK COUPLER/ PIG LAUNDRY STATION.	1
I	2" AIR RELEASE VALVE AND PIPING	1
J	WEATHERPROOF PUMPING PANEL AND CONTROL BOX	1
L	4"x4" MJ WYE	2
M	36" x 60" DOUBLE LEAF ACCESS HATCH	1
N	NOT USED	1
O	4"x4" MJ CROSS	1
P	PRESSURE TRANSDUCER	1
Q	NOT USED	1
R	NOT USED	1
S	4" D.I. GOOSENECK VENT WITH SCREEN TO PREVENT THE ENTRANCE OF INSECTS TO THE WET WELL. MINIMUM 18" HIGHER THAN THE SLAB	1
T	35 GALLON ODOR CONTROL DOSING SYSTEM. LOCATION SET BY CONTRACTOR, CLOSE TO CONTROLLER.	1
U	CLEAN OUT TREE	3
V	SURGE RELIEF VALVE	1

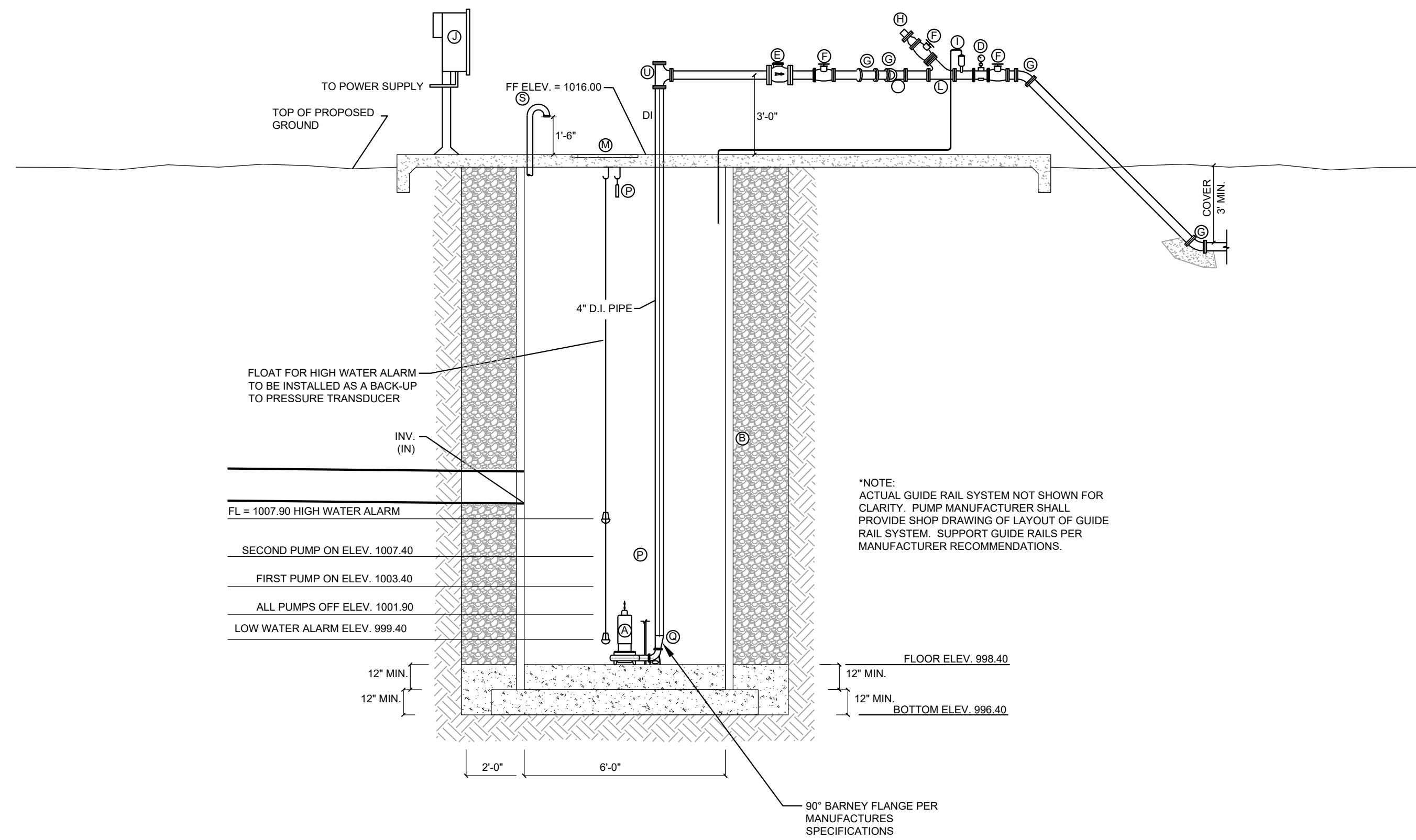

- LIFT STATION GENERAL NOTES:**
- SAWS DESIGN GUIDELINES SHALL GOVERN MATERIAL AND METHODS USED TO DO THIS WORK.
 - ALL LIFT STATION PIPING SHALL BE DUCTILE IRON PIPE (CLASS 50) WITH THRUST BLOCKS ON ALL UNDERGROUND BENDS OR APPROVED EQUAL.
 - ALL DUCTILE IRON COMPONENTS SHALL BE EPOXY LINED AND RATED FOR PRESSURIZED WASTEWATER SERVICE.
 - PROVIDE AIR RELEASE VALVES AT NECESSARY HIGH POINT ON THE PROPOSED FORCE MAIN.
 - SANITARY SEWER FORCE MAIN SHALL BE HDPE DR11.
 - CHECK VALVES AND GATE VALVES SHALL BE RATED FOR PRESSURIZED WASTEWATER SERVICE.
 - ALL LIFT STATION PIPING SHALL BE PROVIDED WITH PIPE SUPPORTS.
 - THE CONTRACTOR SHALL FURNISH AND INSTALL TWO (2) PUMPS, ALL PIPING, CONTROLS, ALARM SYSTEMS, AND RELATED APPURTENANCES FOR ALL PUMPS. THE CONTRACTOR SHALL DO SO ACCORDING TO THE MANUFACTURERS AND PROJECT SPECIFICATIONS.
 - THE CONTRACTOR SHALL INSTALL TWO (2) PLUG OUTLETS (115 VOLT WEATHERPROOF) AT CONTROL PANEL.
 - POWER SERVICE TO CONTROL PANEL SHALL BE UNDERGROUND AND IN CONDUITS TO ACCOMMODATE THREE PHASE ELECTRICAL POWER.
 - AN AUDIO-VISUAL ALARM SYSTEM (RED FLASHING LIGHT AND HORN) SHALL BE PROVIDED FOR ALL LIFT STATIONS. THESE ALARM SYSTEMS SHOULD BE TELEMETERED TO A FACILITY WHERE 24 HOUR ATTENDANCE IS AVAILABLE. THE ALARM SYSTEM SHALL BE ACTIVATED IN CASE OF POWER OUTAGE, PUMP FAILURE OR SPECIFIED HIGH WATER LEVEL.
 - ALL WORK REQUIRED FOR THE LIFT STATION SHALL BE IN ACCORDANCE WITH PROJECT SPECIFICATIONS. ALL MATERIALS, PUMPS, PIPING, CONTROLS ETC. SHALL BE APPROVED BY THE ENGINEER.
 - THE CONTRACTOR SHALL INSTALL TELEPHONE FOR AUTO DIALER.
 - ALL EXTERIOR METAL SURFACES INCLUDING PIPING SHALL RECEIVE ONE COAT OF APPROVED RED LEAD ZINC BASE PRIMER AND ONE COAT OF HIGH GRADE ALUMINUM PAINT.
 - THE CONTRACTOR SHALL MAINTAIN A MINIMUM OF 4' OF COVER FOR ALL FORCE MAIN.
 - LIFT STATION FENCING SHALL BE MINIMUM 6 FEET AND IN ACCORDANCE WITH CITY OF SAN ANTONIO STANDARDS.
 - ANY QUESTIONS FROM THE CONTRACTOR SHALL BE DIRECTED TO THE ENGINEER AS SHOWN ON THE LOGO FOR THE LIFT STATION PLANS.
 - 12" ALL WEATHER ACCESS SHALL BE PROVIDED TO THE LIFT STATION.
 - CONTRACTOR TO PROVIDE A MANUAL TRANSFER SWITCH AND QUICK CONNECTION FOR A PORTABLE GENERATOR.
 - PORTABLE GENERATOR TO BE STORED IN CLOSE PROXIMITY TO THE LIFT STATION.

- LIFT STATION NOTES**
- REFER TO LIFT STATION SPECIFICATIONS FOR PUMP CRITERIA, POWER REQUIREMENTS, AND SYSTEM CONTROLS.
 - CONTRACTOR TO REFERENCE MEP PLANS FOR ELECTRICAL POWER.
 - CONTRACTOR TO INSTALL PACKAGE LIFT STATION PER MANUFACTURER SPECIFICATIONS.
 - FIBERGLASS WET WELL MUST BE ANCHORED TO CONCRETE FOOTING.

Date: 03/19/2023, 10:32am User: D:\mehdiz Layout: LIFT STATION DETAILS File: P:\09\03071-Fulcrum\landmark\Design\30371.dwg Layout name: LIFT STATION DETAILS

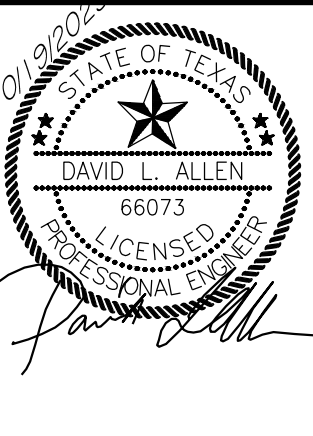

PRIMARY CONTACT: RICHARD HENDRIX, P.E.

MACINA • BOSE • COPELAND & ASSOC., INC.
CONSULTING ENGINEERS AND LAND SURVEYORS
1035 Central Parkway North, San Antonio, Texas 78232
(210) 545-1122 Fax (210) 545-9002 www.mbcengineers.com
FIRM REGISTRATION NUMBER: T.B.P.E. F-784 & T.B.P.L.S. 10011700

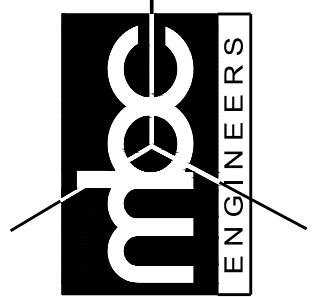

LANDMARK NORTH
SITE WORK AND UTILITY IMPROVEMENTS
SAN ANTONIO, TEXAS
LIFT STATION DETAILS

REVISIONS:	DATE	DESCRIPTION

PLAT ID# 080586
APP# _____
DESIGN# RH
DRAWN# GM
CHECKED# DLA
DATE 03/21/2023
JOB NO. 30371-0976

C10.07

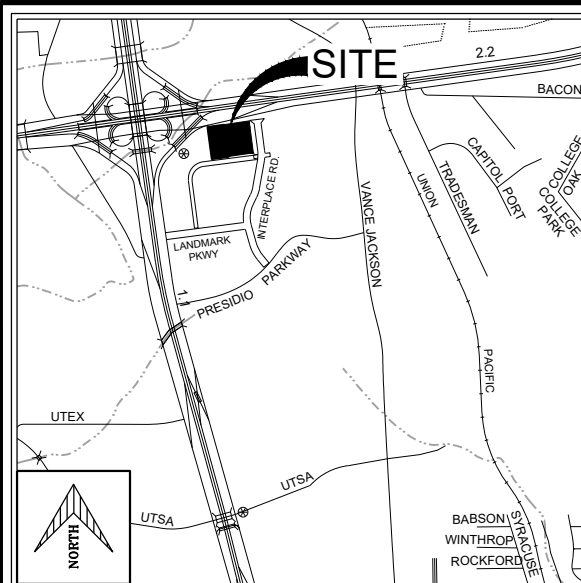

NOTE:
REFERENCE GENERAL NOTES ON SHEET C02.00
PRIOR TO BID AND CONSTRUCTION

IT IS THE CONTRACTOR'S RESPONSIBILITY TO PROPERLY PLAN AND CONSIDER EXISTING AND PROPOSED DRAINAGE PATTERNS DURING THE CONSTRUCTION OF THE PROJECT. IN ORDER TO ACCOMPLISH THIS, IT MAY BE NECESSARY TO PHASE THE GRADING, CONSTRUCT TEMPORARY BERMS AND SWALES WHILE FACTORING IN SURROUNDING CONDITIONS TO PROPERLY DIRECT AND CONTROL SURFACE RUNOFF. ADDITIONALLY, THE CONTRACTOR SHOULD TAKE INTO ACCOUNT THE TIMING OF CONSTRUCTING PONDS, CHANNELS AND STORM DRAINAGE SYSTEMS.

LIFT STATION NOTES:

- ALL ISOLATION VALVES SHALL BE RESILIENT WEDGE GATE VALVES
- ALL CHECK VALVES TO BE LEVER AND WEIGHT SWING CHECK VALVES WITH EXTERNAL ARM
- ALL RESTRAINED FLEXIBLE JOINTS SHALL USE MJ SSB DUCTILE IRON CLASS 350 FITTINGS WITH UNIFLANGE 1400 SERIES RESTRAINTS. ALL UNRESTRAINED FLEXIBLE JOINTS SHALL USE SMITH BLAIR TYPE 441
- THE PUMP CONTROL PANEL SHALL BE CITY OF BOERNE APPROVED AND SHALL BE PLACED SLIGHTLY OFF-CENTER OF WET WELL
- PULL BOXES ARE TO BE MOUNTED ON TOP OF THE WET WELL. THE WET WELL VENT IS TO BE PLACED ADJACENT TO THE PULL BOX, AND BOTH THE PULL BOX AND VENT SHALL BE LOCATED OPPOSITE THE VALVE SLAB
- WET WELL DOOR HINGES SHALL BE PLACED ON THE SAME SIDE AS THE CONTROL SOT THAT THE DOOR OPENS TOWARD THE CONTROL PANEL
- A SAFETY NET SHALL BE INSTALLED BENEATH THE WET WELL DOOR OPENING
- AN ANTIFREEZE AND BFD HOSE BIB SHALL BE INSTALLED INSIDE THE FENCED AREA
- THE WATER LINE SERVING THE LIFT STATION SHALL HAVE AN R/FZ - ABOVE GROUND IN AN INSULATED ENCLOSURE (HOT BOX OR EQUAL)
- NO 90-DEGREE BENDS SHALL BE INSTALLED ON THE FORCE MAIN
- THERE SHALL NOT BE ANY TRANSFORMS, GENERATOR PAD, CONTROL OR ANY STRUCTURE INSTALLED WITHIN 5-FT OF THE FORCE MAIN
- SUBSURFACE DRAINAGE ENTERING THE WET WELL THROUGH PIPE TRENCHES SHALL BE ADDRESSED. CONCRETE RETARDS PLACED ON THE PIPE OR A FRENCH DRAIN SYSTEM MAY BE USED
- ELECTRICAL TRANSFORMER PADS ARE TO BE A 4-FT X 4-FT W/METER PAD AND SHALL BE PLACED OUTSIDE OF THE FENCE AREA
- PORTABLE BACKUP GENERATOR SHALL BE LOCATED WITHIN 15-FT OF THE LIFT STATION
- POSITIVE DRAINAGE AROUND THE WET WELL SHALL BE MAINTAINED. THE SLAB ELEVATIONS OF THE WET WELL AND VALVE VAULT SHALL BE 8-INCHES ABOVE THE SURROUNDING GRADE. THE ELEVATION OF THE WET WELL AND VALVE VAULT SHALL BE THE SAME WHENEVER POSSIBLE. A 2-PERCENT CROSS SLOPE SHALL BE USED ON THE CONCRETE SLABS
- PRIOR TO POURING CONCRETE AROUND THE WET WELL AND VALVE SLAB, THE CONTRACTOR SHALL TAKE STANDARD PROTECTOR DENSITIES AND SUBMIT THE RESULTS TO THE INSPECTOR FOR APPROVAL
- THE SECURITY FENCE GATE SHALL HAVE THE LOCKING MECHANISM ON THE LEFT GATE FACING THE LIFT STATION
- PORTABLE GENERATOR MUST CAPABLE OF OPERATING BOTH PUMPS @ THE SAME TIME

- CONTRACTOR TO CONSTRUCT LIFT STATION IN ACCORDANCE WITH PRIVATE L.S. CRITERIA OVER THE EDWARDS AQUIFER RECHARGE ZONE.
- CONFIGURATIONS AND DIMENSIONS SHOWN ARE BASED ON THE EQUIPMENT SPECIFIED. THE CONTRACTOR SHALL VERIFY THE LAYOUT AND ALL DIMENSIONS PRIOR TO CONSTRUCTION. THE CONTRACTOR SHALL SUBMIT, TO THE ENGINEER, SHOP DRAWINGS SHOWING THE FINAL LAYOUT AND DIMENSIONS PRIOR TO CONSTRUCTION.
- REFERENCE SPECIFICATIONS FOR LIFT STATION EQUIPMENT.
- EPOXY GROUT SEAL PIPING GOING THROUGH CONCRETE WET WELL WALLS.
- VENT PIPE SHALL BE STAINLESS STEEL AND INSTALLED W/ A STAINLESS STEEL INSECT SCREEN. THE OPENING SHALL BE 18" ABOVE THE ENCLOSED AREA
- ALL COUPLINGS SHALL BE EPOXY COATED STEEL AND SHALL BE DRESSER, SMITH-BLAIR, OR EQUAL. COUPLINGS SHALL BE RESTRAINED WITH A THRUST HARNESS DESIGNED IN ACCORDANCE WITH AWWA M-11.
- INSTALL ISOLATION KITS BETWEEN DISSIMILAR METAL PIPING.
- ALL CONCRETE SURFACES WITHIN THE LIFT STATION SHALL BE SEALED WITH A COATING SYSTEM AS DESCRIBED WITHIN THE SPECIFICATIONS. APPLY COATING IN ACCORDANCE WITH THE MANUFACTURER'S INSTRUCTIONS AND CITY OF BOERNE CRITERIA MANUAL FOR SURFACE PREPARATION AND APPLICATION TO ALL INTERIOR CONCRETE SURFACES.
- ALL DUCTILE IRON PIPING SHALL BE RATED FOR A WORKING PRESSURE OF 350 PSI. ALL DUCTILE IRON PIPING INSTALLED ABOVE GROUND SHALL BE FLANGED.
- ALL EXPOSED METAL AND PIPING WITHIN THE WET WELL SHALL BE GRADE 316 STAINLESS STEEL. ALL STAINLESS STEEL PIPING SHALL BE RATED FOR A WORKING PRESSURE OF 250 PSI.
- ALL FITTINGS BETWEEN DUCTILE IRON PIPE SHALL BE RESTRAINED WITH MEGALUG FITTINGS AS MANUFACTURED BY EBAA IRON INC., OR APPROVED EQUAL.
- CONTRACTOR SHALL PROVIDE STRUCTURAL DESIGN OF WET WELL AND SUBMIT TO ENGINEER FOR REVIEW.
- WET WELL EXCAVATION METHODS SHALL BE SUBMITTED TO THE ENGINEER.
- ALL PIPES, VALVES, FLANGES, AND FITTINGS OUTSIDE THE WET WELL SHALL RECEIVE AFTER INSTALLATION A 100% SOLIDS EPOXY SYSTEM WITH A TOP COAT SYSTEM OF URETHANE. COLOR SHALL BE GREY PANTONE #431-U
- CONTRACTOR SHALL ALUMINUM INSTALL SAFETY GRATE UNDER WET WELL ACCESS HATCH
- THE FIRST RUNG OFF THE VAULT FLOOR SHALL BE INSTALLED 17" FROM CENTER OF RUNG ABOVE FINISHED FLOOR ELEVATION. CONTRACTOR TO VERIFY ALL LENGTHS AND DIMENSIONS PRIOR TO FABRICATION.

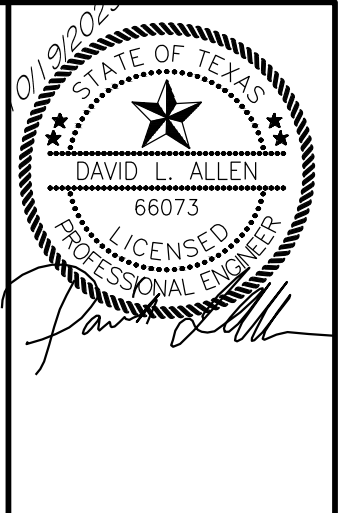

PRIMARY CONTACT:
RICHARD HENDRIX, P.E.

MACINA • BOSE • COPELAND & ASSOC., INC.
CONSULTING ENGINEERS AND LAND SURVEYORS
1035 Central Parkway North, San Antonio, Texas 78232
(210) 545-1122 Fax (210) 545-9002 www.mbcengineers.com
FIRM REGISTRATION NUMBER: T.B.P.E. F-784 & T.B.P.L.S. 10011700

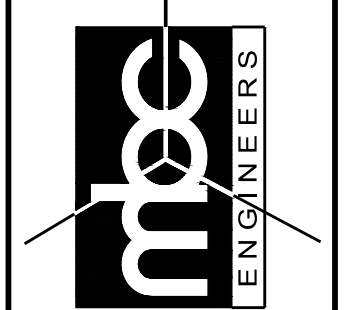

LANDMARK NORTH
SITE WORK AND UTILITY IMPROVEMENTS
SAN ANTONIO, TEXAS
LIFT STATION DETAILS - 2

**Edwards Aquifer Recharge Zone
San Antonio**

PUMP CYCLE CALCULATOR

INPUT DATA

- Wet Well Diameter (in) _____
- Pump Down Distance (in) _____
- Working Volume (gal) _____
- Average Pump Flow (gpm) _____
- Surcharge Volume (if applicable*) _____
- Lift Station Inflow Rate (gpm) _____

	72
Wet Well Diameter (in)	18
Pump Down Distance (in)	79
Working Volume (gal)	52
Average Pump Flow (gpm)	0
Surcharge Volume (if applicable*)	5
Lift Station Inflow Rate (gpm)	10
	15
	20
	25
	30
	35
	40
	45
	50
	55



CALCULATED RESULTS @ ABOVE INFLOW GPM

- Working Volume Fill Time (Storage Time) (min) _____
- Pump Run Time without Inflow (min) _____
- Pump Run Time with Inflow (min) _____
- Pump Run Time + Refill Time (Cycle Time) (min) _____
- Starts / HR with Inflow _____

15.9	7.9	5.3	4.0	3.2	2.6	2.3	2.0	1.8	1.6	1.4
1.5	1.5	1.5	1.5	1.5	1.5	1.5	1.5	1.5	1.5	1.5
1.7	1.9	2.1	2.5	2.9	3.6	4.7	6.6	11.3	39.7	-26.4
17.6	9.8	7.4	6.4	6.1	6.2	6.9	8.6	13.1	41.2	-25.0
3.4	6.1	8.1	9.3	9.8	9.6	8.7	7.0	4.6	1.5	-2.4

* If a surcharge volume is entered, it will be added to Pump Down Volume and included in all calculations.

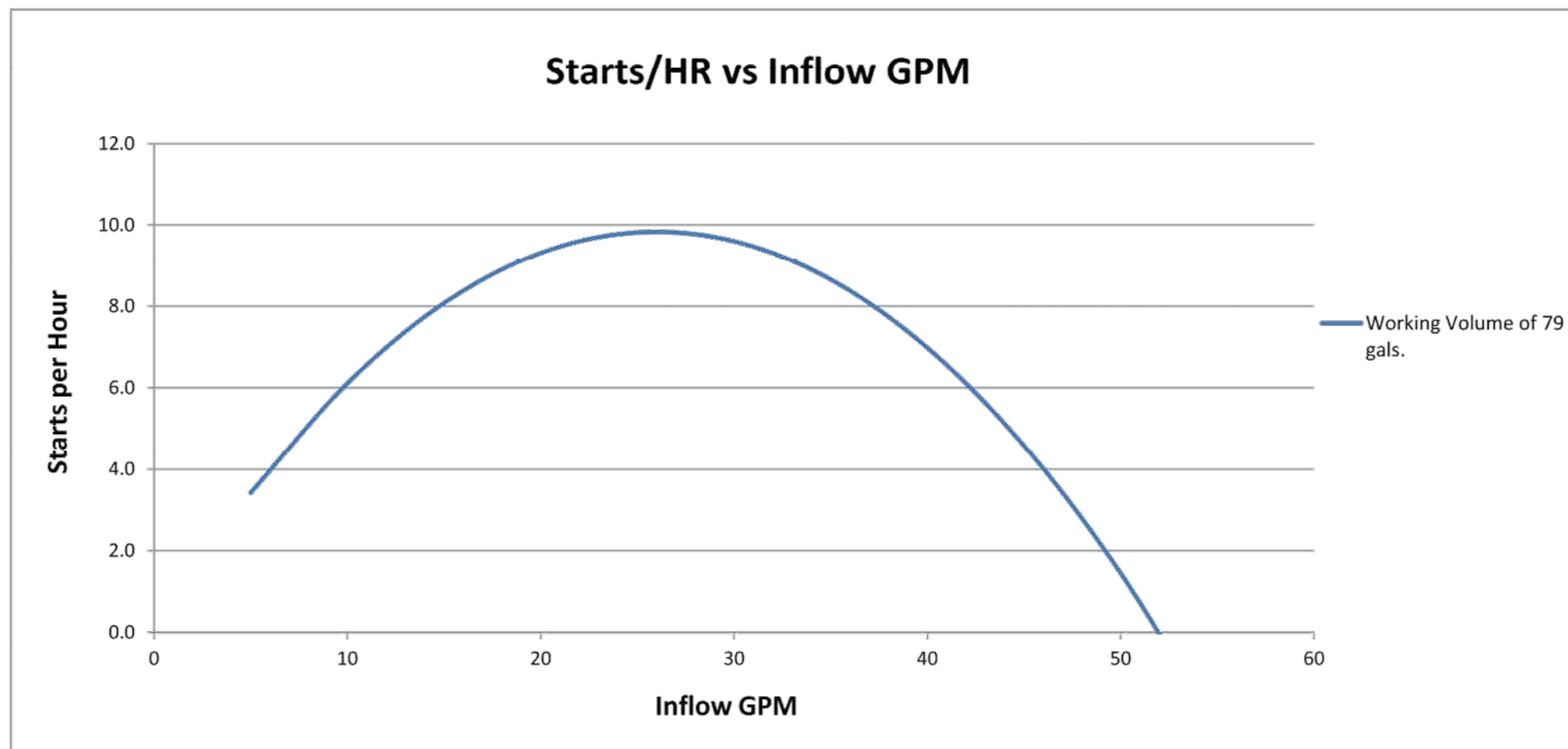

Conclusion:

If the OFF float and LEAD float are spaced 18 inches apart, the pump cycle will be 9.8 starts per hour at worst case inflow rate.

The submersible pump manufacturer will allow around 10 starts per hour maximum for a pump this size for proper heat dissipation.

PUMP PERFORMANCE CRITERIA

- a. Capacity (GPM) ----- 60
- b. Maximum TDH (FT) ----- 15
- c. Maximum Pump Speed (RPM) ----- 3450
- d. Minimum Efficiency (%) ----- 34
- e. Minimum Submergence Depth (FT) ----- 1.5
- f. Minimum Motor Size (HP) ----- 2.5

Lift Station Basin and Float Setting Elevations

**Edwards Aquifer Recharge Zone
San Antonio**

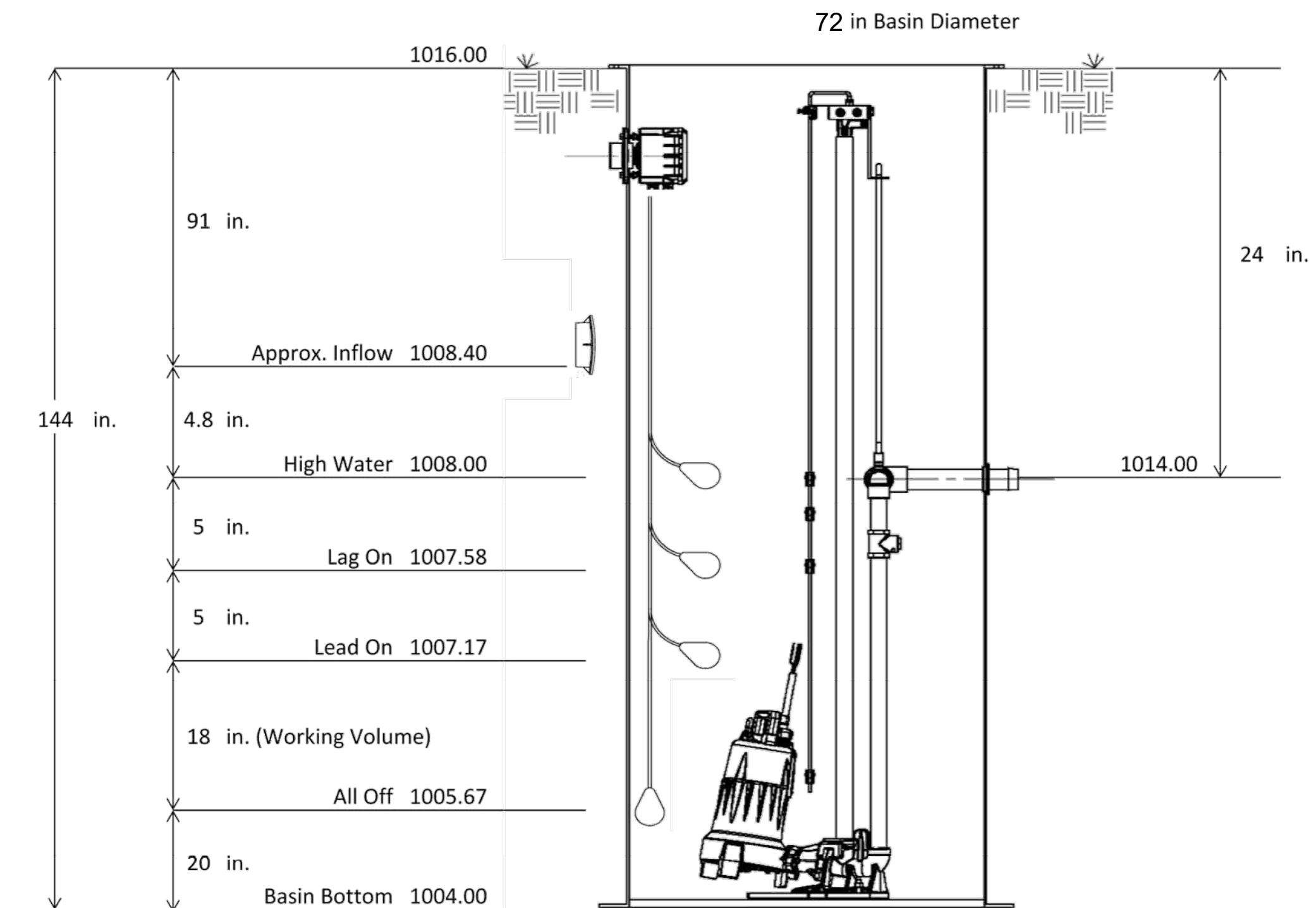

(This drawing is not to scale)

REVISIONS:	DATE	BY	DESCRIPTION

PLAT ID#	080586
APP#	
DESIGN	RH
DRAWN	GM
CHECKED	DLA
DATE	03/21/2023
JOB NO.	30371-0976

C10.08

– **Temporary Stormwater Section (TCEQ-0602)**

Attachment A - Spill Response Actions

Attachment B - Potential Sources of Contamination

Attachment C - Sequence of Major Activities

Attachment D - Temporary Best Management Practices and Measures

Attachment E - Request to Temporarily Seal a Feature, if sealing a feature

Attachment F - Structural Practices

Attachment G - Drainage Area Map

Attachment H - Temporary Sediment Pond(s) Plans and Calculations

Attachment I - Inspection and Maintenance for BMPs

Attachment J - Schedule of Interim and Permanent Soil Stabilization Practices

Temporary Stormwater Section

Texas Commission on Environmental Quality

for Regulated Activities on the Edwards Aquifer Recharge Zone and Relating to 30 TAC §213.5(b)(4)(A), (B), (D)(I) and (G); Effective June 1, 1999

To ensure that the application is administratively complete, confirm that all fields in the form are complete, verify that all requested information is provided, consistently reference the same site and contact person in all forms in the application, and ensure forms are signed by the appropriate party.

Note: Including all the information requested in the form and attachments contributes to more streamlined technical reviews.

Signature

To the best of my knowledge, the responses to this form accurately reflect all information requested concerning the proposed regulated activities and methods to protect the Edwards Aquifer. This **Temporary Stormwater Section** is hereby submitted for TCEQ review and executive director approval. The application was prepared by:

Print Name of Customer/Agent: Richard W. Hendrix, P.E.

Date: 10/19/2023

Signature of Customer/Agent:



Regulated Entity Name: Landmark North-West

Project Information

Potential Sources of Contamination

Examples: Fuel storage and use, chemical storage and use, use of asphaltic products, construction vehicles tracking onto public roads, and existing solid waste.

1. Fuels for construction equipment and hazardous substances which will be used during construction:

The following fuels and/or hazardous substances will be stored on the site: _____

These fuels and/or hazardous substances will be stored in:

- Aboveground storage tanks with a cumulative storage capacity of less than 250 gallons will be stored on the site for less than one (1) year.

- Aboveground storage tanks with a cumulative storage capacity between 250 gallons and 499 gallons will be stored on the site for less than one (1) year.
- Aboveground storage tanks with a cumulative storage capacity of 500 gallons or more will be stored on the site. An Aboveground Storage Tank Facility Plan application must be submitted to the appropriate regional office of the TCEQ prior to moving the tanks onto the project.
- Fuels and hazardous substances will not be stored on the site.
- 2. **Attachment A - Spill Response Actions.** A site specific description of the measures to be taken to contain any spill of hydrocarbons or hazardous substances is attached.
- 3. Temporary aboveground storage tank systems of 250 gallons or more cumulative storage capacity must be located a minimum horizontal distance of 150 feet from any domestic, industrial, irrigation, or public water supply well, or other sensitive feature.
- 4. **Attachment B - Potential Sources of Contamination.** A description of any activities or processes which may be a potential source of contamination affecting surface water quality is attached.

Sequence of Construction

- 5. **Attachment C - Sequence of Major Activities.** A description of the sequence of major activities which will disturb soils for major portions of the site (grubbing, excavation, grading, utilities, and infrastructure installation) is attached.
 - For each activity described, an estimate (in acres) of the total area of the site to be disturbed by each activity is given.
 - For each activity described, include a description of appropriate temporary control measures and the general timing (or sequence) during the construction process that the measures will be implemented.
- 6. Name the receiving water(s) at or near the site which will be disturbed or which will receive discharges from disturbed areas of the project: Leon Creek

Temporary Best Management Practices (TBMPs)

Erosion control examples: tree protection, interceptor swales, level spreaders, outlet stabilization, blankets or matting, mulch, and sod. Sediment control examples: stabilized construction exit, silt fence, filter dikes, rock berms, buffer strips, sediment traps, and sediment basins. Please refer to the Technical Guidance Manual for guidelines and specifications. All structural BMPs must be shown on the site plan.

- 7. **Attachment D – Temporary Best Management Practices and Measures.** TBMPs and measures will prevent pollution of surface water, groundwater, and stormwater. The construction-phase BMPs for erosion and sediment controls have been designed to retain sediment on site to the extent practicable. The following information is attached:

- A description of how BMPs and measures will prevent pollution of surface water, groundwater or stormwater that originates upgradient from the site and flows across the site.
 - A description of how BMPs and measures will prevent pollution of surface water or groundwater that originates on-site or flows off site, including pollution caused by contaminated stormwater runoff from the site.
 - A description of how BMPs and measures will prevent pollutants from entering surface streams, sensitive features, or the aquifer.
 - A description of how, to the maximum extent practicable, BMPs and measures will maintain flow to naturally-occurring sensitive features identified in either the geologic assessment, TCEQ inspections, or during excavation, blasting, or construction.
8. The temporary sealing of a naturally-occurring sensitive feature which accepts recharge to the Edwards Aquifer as a temporary pollution abatement measure during active construction should be avoided.
- Attachment E - Request to Temporarily Seal a Feature.** A request to temporarily seal a feature is attached. The request includes justification as to why no reasonable and practicable alternative exists for each feature.
 - There will be no temporary sealing of naturally-occurring sensitive features on the site.
9. **Attachment F - Structural Practices.** A description of the structural practices that will be used to divert flows away from exposed soils, to store flows, or to otherwise limit runoff discharge of pollutants from exposed areas of the site is attached. Placement of structural practices in floodplains has been avoided.
10. **Attachment G - Drainage Area Map.** A drainage area map supporting the following requirements is attached:
- For areas that will have more than 10 acres within a common drainage area disturbed at one time, a sediment basin will be provided.
 - For areas that will have more than 10 acres within a common drainage area disturbed at one time, a smaller sediment basin and/or sediment trap(s) will be used.
 - For areas that will have more than 10 acres within a common drainage area disturbed at one time, a sediment basin or other equivalent controls are not attainable, but other TBMPs and measures will be used in combination to protect down slope and side slope boundaries of the construction area.
 - There are no areas greater than 10 acres within a common drainage area that will be disturbed at one time. A smaller sediment basin and/or sediment trap(s) will be used in combination with other erosion and sediment controls within each disturbed drainage area.

- There are no areas greater than 10 acres within a common drainage area that will be disturbed at one time. Erosion and sediment controls other than sediment basins or sediment traps within each disturbed drainage area will be used.
11. **Attachment H - Temporary Sediment Pond(s) Plans and Calculations.** Temporary sediment pond or basin construction plans and design calculations for a proposed temporary BMP or measure have been prepared by or under the direct supervision of a Texas Licensed Professional Engineer. All construction plans and design information must be signed, sealed, and dated by the Texas Licensed Professional Engineer. Construction plans for the proposed temporary BMPs and measures are attached.
- N/A
12. **Attachment I - Inspection and Maintenance for BMPs.** A plan for the inspection of each temporary BMP(s) and measure(s) and for their timely maintenance, repairs, and, if necessary, retrofit is attached. A description of the documentation procedures, recordkeeping practices, and inspection frequency are included in the plan and are specific to the site and/or BMP.
13. All control measures must be properly selected, installed, and maintained in accordance with the manufacturer's specifications and good engineering practices. If periodic inspections by the applicant or the executive director, or other information indicate a control has been used inappropriately, or incorrectly, the applicant must replace or modify the control for site situations.
14. If sediment escapes the construction site, off-site accumulations of sediment must be removed at a frequency sufficient to minimize offsite impacts to water quality (e.g., fugitive sediment in street being washed into surface streams or sensitive features by the next rain).
15. Sediment must be removed from sediment traps or sedimentation ponds not later than when design capacity has been reduced by 50%. A permanent stake will be provided that can indicate when the sediment occupies 50% of the basin volume.
16. Litter, construction debris, and construction chemicals exposed to stormwater shall be prevented from becoming a pollutant source for stormwater discharges (e.g., screening outfalls, picked up daily).

Soil Stabilization Practices

Examples: establishment of temporary vegetation, establishment of permanent vegetation, mulching, geotextiles, sod stabilization, vegetative buffer strips, protection of trees, or preservation of mature vegetation.

17. **Attachment J - Schedule of Interim and Permanent Soil Stabilization Practices.** A schedule of the interim and permanent soil stabilization practices for the site is attached.

18. Records must be kept at the site of the dates when major grading activities occur, the dates when construction activities temporarily or permanently cease on a portion of the site, and the dates when stabilization measures are initiated.
19. Stabilization practices must be initiated as soon as practicable where construction activities have temporarily or permanently ceased.

Administrative Information

20. All structural controls will be inspected and maintained according to the submitted and approved operation and maintenance plan for the project.
21. If any geologic or manmade features, such as caves, faults, sinkholes, etc., are discovered, all regulated activities near the feature will be immediately suspended. The appropriate TCEQ Regional Office shall be immediately notified. Regulated activities must cease and not continue until the TCEQ has reviewed and approved the methods proposed to protect the aquifer from any adverse impacts.
22. Silt fences, diversion berms, and other temporary erosion and sediment controls will be constructed and maintained as appropriate to prevent pollutants from entering sensitive features discovered during construction.

FORM 0602 ATTACHMENTS

ATTACHMENT “A” - SPILL RESPONSE

In the event of a spill involving hydrocarbons or other hazardous substances, the contractor will immediately notify TCEQ (at 210-490-3096) and the engineer (210 545-1122) explaining the type and nature of the spill. The contractor shall be required to maintain a sufficient stockpile of sand material in the staging area. This sand material shall be used to immediately isolate and provide containment of the spill by constructing dikes. Furthermore, this sand material shall act as an absorbent material that can be disposed of offsite and out of the Recharge Zone during cleanup operations. All contaminated soils resulting from an accidental release will be required to be removed and disposed of in accordance with all local, state, and federal regulations.

The objective of this attachment is to describe measures to prevent or reduce the discharge of pollutants to drainage systems or watercourses from leaks and spills by reducing the chance for spills, stopping the source of spills, containing and cleaning up spills, properly disposing of spill materials, and training employees. The following steps will help reduce the storm water impacts of leaks and spills:

Education

(1) Be aware that different materials pollute in different amounts. Make sure that each employee knows what a “significant spill” is for each material they use, and what is the appropriate response for “significant” and “insignificant” spills. Employees should also be aware of when spill must be reported to the TCEQ. Information is available in 30 TAC 327.4 and 40 CFR 302.4.

(2) Educate employees and subcontractors on potential dangers to humans and the environment from spills and leaks.

(3) Hold regular meetings to discuss and reinforce appropriate disposal procedures (incorporate into regular safety meetings).

(4) Establish a continuing education program to indoctrinate new employees.

(5) Have contractor’s superintendent or representative oversee and enforce proper spill prevention and control measures.

General Measures

(1) To the extent that the work can be accomplished safely, spills of oil, petroleum products, and substances listed under 40 CFR parts 110,117, and 302, and sanitary and septic wastes should be contained and cleaned up immediately.

- (2) Store hazardous materials and wastes in covered containers and protect from vandalism.
- (3) Place a stockpile of spill cleanup materials where it will be readily accessible.
- (4) Train employees in spill prevention and cleanup.
- (5) Designate responsible individuals to oversee and enforce control measures.
- (6) Spills should be covered and protected from storm-water runoff during rainfall to the extent that it doesn't compromise clean-up activities.
- (7) Do not bury or wash spills with water.
- (8) Store and dispose of used clean up materials, contaminated materials, and recovered spill material that is no longer suitable for the intended purpose in conformance with the provisions in applicable BMPs.
- (9) Do not allow water used for cleaning and decontamination to enter storm drains or watercourses. Collect and dispose of contaminated water in accordance with applicable regulations.
- (10) Contain water overflow or minor water spillage and do not allow it to discharge into drainage facilities or watercourses.
- (11) Place Material Safety Data Sheets (MSDS), as well as proper storage, cleanup, and spill reporting instructions for hazardous materials stored or used on the project site in an open, conspicuous, and accessible location.
- (12) Keep waste storage areas clean, well-organized, and equipped with ample cleanup supplies as appropriate for the materials being stored. Perimeter controls, containment structures, covers, and liners should be repaired or replaced as needed to maintain proper function.

Cleanup

- (1) Clean up leaks and spills immediately.
- (2) Use a rag for small spills on paved surfaces, a damp mop for general cleanup, and absorbent material for larger spills. If the spilled material is hazardous, then the used cleanup materials are also hazardous and must be disposed of as hazardous waste.
- (3) Never hose down or bury dry material spills. Clean up as much of the material as possible and dispose of properly. See the waste management BMPs in this section for specific information.

Minor Spills

- (1) Minor spills typically involve small quantities of oil, gasoline, paint, etc. which can be controlled by the first responder at the discovery of the spill.
- (2) Use absorbent materials on small spills rather than hosing down or burying the spill.
- (3) Absorbent materials should be promptly removed and disposed of properly.
- (4) Follow the practice below for a minor spill:
- (5) Contain the spread of the spill.
- (6) Recover spilled materials.
- (7) Clean the contaminated area and properly dispose of contaminated materials.

Semi-Significant Spills

Semi-significant spills still can be controlled by the first responder along with the aid of other personnel such as laborers and the foreman, etc. This response may require the cessation of all other activities.

Spills should be cleaned up immediately:

- (1) Contain spread of the spill.
- (2) Notify the project foreman immediately.
- (3) If the spill occurs on paved or impermeable surfaces, clean up using "dry" methods (absorbent materials, cat litter and/or rags). Contain the spill by encircling with absorbent materials and do not let the spill spread widely.
- (4) If the spill occurs in dirt areas, immediately contain the spill by constructing an earthen dike. Dig up and properly dispose of contaminated soil.
- (5) If the spill occurs during rain, cover spill with tarps or other material to prevent contaminating runoff.

Significant/Hazardous Spills

For significant or hazardous spills that are in reportable quantities:

- (1) Notify the TCEQ by telephone as soon as possible and within 24 hours at 512-339-2929 (Austin) or 210-490-3096 (San Antonio) between 8 AM and 5 PM.

After hours, contact the Environmental Release Hotline at 1-800-832-8224. It is the contractor's responsibility to have all emergency phone numbers at the construction site.
(2) For spills of federal reportable quantities, in conformance with the requirements in 40 CFR parts 110,119, and 302, the contractor should notify the National Response Center at (800) 424-8802.

(3) Notification should first be made by telephone and followed up with a written report.

(4) The services of a spills contractor or a Haz-Mat team should be obtained immediately. Construction personnel should not attempt to clean up until the appropriate and qualified staffs have arrived at the job site.

(5) Other agencies which may need to be consulted include, but are not limited to, the City Police Department, County Sheriff Office, Fire Departments, etc.

More information on spill rules and appropriate responses is available on the TCEQ website at: http://www.tnrcc.state.tx.us/enforcement/emergency_response.html

Vehicle and Equipment Maintenance

(1) If maintenance must occur on-site, use a designated area and a secondary containment, located away from drainage courses, to prevent the run-on of storm-water and the runoff of spills.

(2) Regularly inspect onsite vehicles and equipment for leaks and repair immediately

(3) Check incoming vehicles and equipment (including delivery trucks, employee, and subcontractor vehicles) for leaking oil and fluids. Do not allow leaking vehicles or equipment onsite.

(4) Always use secondary containment, such as a drain pan or drop cloth, to catch spills or leaks when removing or changing fluids.

(5) Place drip pans or absorbent materials under paving equipment when not in use.

(6) Use absorbent materials on small spills rather than hosing down or burying the spill. Remove the absorbent materials promptly and dispose of properly.

(7) Promptly transfer used fluids to the proper waste or recycling drums. Don't leave full drip pans or other open containers lying around.

(8) Oil filters disposed of in trashcans or dumpsters can leak oil and pollute storm-water. Place the oil filter in a funnel over a waste oil-recycling drum to drain excess oil before disposal. Oil filters can also be recycled. Ask the oil supplier or recycler about recycling oil filters.

(9) Store cracked batteries in a non-leaking secondary container. Do this with all cracked batteries even if you think all the acid has drained out. If you drop a battery, treat it as if it is cracked. Put it into the containment area until you are sure it is not leaking.

Vehicle and Equipment Fueling

(1) If fueling must occur on site, use designated areas, located away from drainage courses, to prevent the run-on of storm-water and the runoff of spills.

(2) Discourage “topping off” of fuel tanks.

(3) Always use secondary containment, such as a drain pan, when fueling to catch spills/leaks.

ATTACHMENT “B” – POTENTIAL SOURCES OF CONTAMINATION

Other potential sources are:

1. Oil and gasoline leaks from construction equipment.
2. Vehicles tracking in and out of the project.
3. Asphaltic paving and associated materials.
4. Minor leakage or spillage of paints, lacquers, solvents, etc., used in conjunctions with building construction which may occur simultaneously with infrastructure construction.
5. Leakage from self-contained portable toilet facilities.

ATTACHMENT “C” – SEQUENCE OF MAJOR ACTIVITIES

1. Install all Temporary BMP’s (rock berms and silt fencing), construction entrance, and tree protection for on-site construction. (8.5 acres)
2. Clear site of brush, trees and any existing debris & prepare area for construction (8.0 acres)
3. Excavate and fill site as dictated by the grading plan (8.0 acres)
4. Construct underground storm drains to route runoff to BMP’s (4.5 acres)
5. Install inlet protection on all curb and grate inlets (4.5 acres)
6. Construct building pads (0.84 acres)
7. Install utilities; sewer laterals, water services, and underground electric (4.50 acres)
8. Construct Building (0.84 acres)
9. Fine grade site (8.0 acres)
10. Construct paved surfaces; concrete parking areas & sidewalks (5.0 acres)
11. Install landscaping (1.5 acres)
12. Remove any left-over debris after construction (8.0 acres)
13. Remove temporary BMPs (8.5 acres)

ATTACHMENT “D” - Temporary Best Management Practices

A) There is no up-gradient water flowing onto the site. Underground storm drain systems are proposed to take the treated and untreated run-off through site. The run-off will then discharge through outfall structures and be allowed to flow toward Leon Creek north of the site.

B) All contractors, subcontractors, and builders shall endeavor to avoid the pollution of runoff water by using “best management practices” and reasonable foresight to avoid contact between runoff water and polluting materials.

Some best management practices to which all parties are expected to conform are as follows:

1. Prior to the beginning of the work listed in “Attachment C”, the contractor will install the sediment control barriers as specified on the separate “Temporary Pollution Abatement Plan” which is attached at the end of this section. These barriers (silt fences, etc.) will be maintained during the entire time construction is in progress. Thus erodible material and pollution that might be generated during construction will be intercepted by these same barriers.
2. The installation of a stabilized construction entrance/exit(s) and a construction staging area to reduce the dispersion of sediment from the site.
3. The silt fences specified on the “Temporary Pollution Abatement Plan” were positioned to be down-gradient of all construction zones. Thus, with proper installation and maintenance these barriers shall be effective in preventing potentially contaminated runoff from leaving the site.
4. The general contractor shall develop a written plan to control the generation of dust during construction phase and submit it to the developer.
5. Builders and their contractors shall clean equipment only onto areas protected by their silt fences or dikes. Set forth in the TBMP’s plan is a location where a “Concrete Truck Washout Pit” will be constructed. The builder shall inform his concrete supplier that this Washout Pit is the only point in the project where washout and waste concrete mix may be discharged.
6. Stockpiles of erodible material (topsoil, sand, etc.) shall be placed in areas only protected by silt fences or other erosion barriers.
7. All contractors shall provide self-contained toilet facilities for their employees.
8. Chemicals, solvents, paints, and other potentially toxic materials must be stored in such a manner that they are protected from rainfall and surface runoff water.

9. All contractors shall provide waste receptacles at locations convenient to their construction area; to protect from leaching by rainfall; and provide regular collection.

C) Temporary measures installed onsite are intended to provide a method of slowing the flow of runoff from the construction site in order to allow sediment and suspended solids to settle out of the runoff. By containing the sediment and solids within the site, they will not enter the aquifer, sensitive features, or surface streams downgradient of the site.

D) BMP measures utilized in this plan are intended to allow stormwater to continue downstream after passing through the BMP's. This will allow stormwater runoff to continue downgradient to streams or features that may exist downstream of the site.

If any sensitive features are discovered during construction, all regulated activities near the sensitive feature shall be suspended. The TCEQ Regional office will be notified immediately and a plan will be submitted to TCEQ for treatment of the feature. See note 3 of TCEQ WPAP General Construction Notes.

San Antonio Regional Office 14250 Judson Road San Antonio, Texas 78233-4480 Phone (210) 490-3096 Fax (210) 545-4329	State of Texas Spill-Reporting Hotline (800) 832-8224 Bexar County Storm Water Quality (210) 335-6663
---	--

ATTACHMENT “E” – Request to Temporarily Seal a Feature

Not Applicable

ATTACHMENT “F” – Structural Practices

The following measures will be installed as part of the site preparation activities:

- Erection of silt fences along the downgradient boundary of construction activities.
- Inlet protection will be installed.
- Stabilized construction entrance/exit(s) will be installed.
- A construction staging area will be designated.
- Concrete truck washout pit(s) will be installed where required to facilitate controlled disposal of concrete truck washout.

ATTACHMENT “G” – Drainage Area Map

Please reference the attached drawing illustrating the proposed drainage areas and sub-areas. Other erosion controls within each disturbed area will be used, such as silt fencing and inlet protection.

ATTACHMENT “H”- Temporary Sediment Pond Plans and Calculations

Not Applicable. No areas greater than 10 acres with a common drainage area will be disturbed at one time. A sedimentation/filtration pond exists on-site and has been designed for ultimate development of the overall drainage area.

ATTACHMENT “I” – Inspection and Maintenance

All TBMP’S shall be inspected by the contractor on a weekly basis and after all substantial rain events. The contractor shall keep records of all inspections that were made. Also the contractor shall repair or replace any damaged or dysfunctional TBMP’s. The contractor shall insure that all TBMP’s are maintained and inspected according to TCEQ’s Technical Guidance Manual.

Inspection and Maintenance shall include but is not limited to:

For the Construction Entrance:

- The contractor shall maintain the entrance in a condition which will prevent tracking or flowing of sediment onto public right-of-way. This may require periodic top dressing with additional stone as conditions demand and repair and/or cleanout of any measures used to trap sediment.
- The contractor shall immediately remove any and all sediment spilled, dropped, washed or tracked onto public rights-of-way.
- When necessary, the contractor shall clean wheels to remove sediment prior to entrance onto public rights-of-way.
- When washing is required, it should be done on an area stabilized with crushed stone that drains into an approved sediment trap or sediment basin.
- The contractor shall prevent all sediment from entering any storm drain, ditch, or water course by using approved methods.

For Silt Fencing:

- The contractor shall inspect all silt fencing weekly and after any rainfall for sediment accumulation, torn fabric and crushed or collapsed sections throughout the duration of construction.
- Sediment shall be removed when sediment buildup reaches 6 inches, or a second line of fencing shall be installed parallel to the original fence.
- Torn fabric shall be replaced by the contractor; a second line of fencing shall be erected parallel to the torn section if replacement is not feasible.
- Contractor shall replace or repair any fence sections crushed or collapsed during the course of construction. Silt fence may be relocated by the contractor to a location where it will provide equal protection should the original/planned installation obstruct vehicular access to the site.

- When construction is complete, the sediment should be disposed of in a manner that will not cause additional siltation and the prior location of the silt fence should be re-vegetated. The fence itself should be disposed of in an approved landfill.

For Rock Berms:

- The contractor shall inspect all rock berms weekly and after any rainfall for sediment accumulation, debris building up, or damage throughout the duration of construction.
- Sediment and other debris shall be removed when sediment buildup reaches 6 inches. The accumulated silt and debris shall be disposed in an approved manner that will not cause any additional siltation.
- The contractor to repair any loose wire sheathing.
- The contractor shall reshape the berm as needed during inspection throughout the duration of construction.
- The contractor shall replace the berm when the structure ceases to function as intended due to silt accumulation among the rocks, washout, construction traffic damage, etc.
- The rock berm shall remain in place until all upstream areas are stabilized and accumulated silt removed.

For Grate and Curb Inlet Protection:

- The contractor shall inspect all inlet protection weekly and after any rainfall for sediment accumulation, debris building up, or damage throughout the duration of construction. Repair or replacement should be made promptly as needed by the contractor.
- Sediment and other debris shall be removed when sediment buildup reaches 3 inches. The removed sediment shall be deposited in a suitable area and in such a manner that it will not erode.
- The contractor shall check placement of inlet protection measures to prevent gaps between these measures and the curb.
- The contractor shall inspect the filter fabric and patch or replace if torn or missing.
- Records will be kept with the construction site Superintendent of all inspection and maintenance actions. See maintenance record chart next on the next page.

For Concrete Washout Pit

- The contractor shall inspect all concrete washout pits weekly and after any rainfall.
- Contractor shall ensure that all excess concrete is being washed out into the designated washout pits only.
- The hardened concrete shall be disposed of when the pit is no longer required and when it becomes full.

General

- Records will be kept with the construction site superintendent of all inspections and maintenance actions. See the attached maintenance record chart.
- Litter, construction debris, and construction chemicals exposed to storm water shall be prevented from becoming a pollutant source for storm water discharges (e.g., screening outfalls, picked up daily).
- If sediment escapes the construction site, off site accumulations of sediment must be removed at a frequency sufficient to minimize offsite impacts to water quality (e.g., fugitive sediment in street being washed into surface streams or sensitive features by the next rain).

Temporary Stormwater Section Attachment "I" continued

ITEM #	DATE	DESCRIPTION OF ACTION(S) TAKEN	INITIALS

ATTACHMENT “J” – Interim and Permanent Soil Stabilization

Interim on-site stabilization measures, which are continuous, will include minimizing soil disturbances by exposing only the smallest practical area of land required for the shortest period of time and maximizing use of natural vegetation. As soon as practical, all disturbed soil will be stabilized as per project specifications in accordance with pages 1-35 to 1-60 of TCEQ's Technical Guidance Manual (TGM) RG-348 (2005).

Stabilization measures will be initiated as soon as practicable in portions of the site where construction activities have temporarily or permanently ceased, and except as provided below, will be initiated no more than fourteen (14) days after the construction activity in that portion of the site has temporarily or permanently ceased. Where construction activity on a portion of the site is temporarily ceased, and earth disturbing activities will be resumed within twenty-one (21) days, temporary stabilization measures do not have to be initiated on that portion of site. In areas experiencing droughts where the initiation of stabilization measures by the 14th day after construction activity has temporarily or permanently ceased is precluded by seasonably arid conditions, stabilization measures must be initiated as soon as practicable.

The site shall be stabilized with sod and/or seed upon the completion of construction. If construction is to temporarily cease and temporary stabilization is required as noted above, the exposed soil shall be stabilized by mulch until construction resumes.

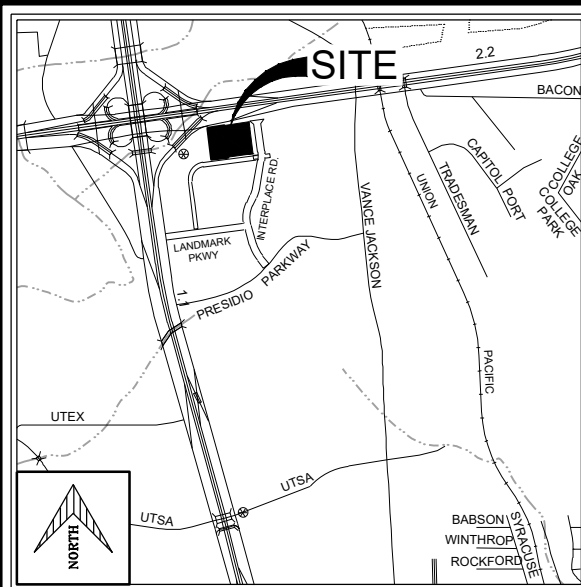

HYDROLOGY CALCULATIONS

Inlet/Study Point	Structure/Description	Contributing Area (acres)	C _w *	Overland Flow (Equation 3-3, TR-55)					Shallow Concentrated Flow (Figure 3-1, TR-55)				Channel Flow			Total Time of Conc. (min)	15-MINUTE UNIT HYDROGRAPHS (FHWA Exhibit 14)									
				Surface Condition	n	P ₂ (in)	L (ft)	S (ft/ft)	T ₁ (min)	Surface	L (ft)	S (ft/ft)	T _{1c} (min)	L (ft)	V (ft/s)		T _{cb} (min)	T _c (min)	I ₁ (in/hr)	I ₅ (in/hr)	I ₁₅ (in/hr)	I ₃₀ (in/hr)	Q ₁ (cfs)	Q ₅ (cfs)	Q ₁₅ (cfs)	Q ₃₀ (cfs)
Proposed/Ultimate Conditions																										
1a1	Prop. Storm Drain	A1-A2	21.82	0.88	Bermudagrass	0.41	3.96	40	0.02	9.5	Paved	335	0.019	2.0	1615	6	4.5	16	3.50	5.10	7.07	8.79	67.2	97.9	135.8	168.8
1a2	Prop. Storm Drain	A1-A3	26.39	0.89	Bermudagrass	0.41	3.96	40	0.02	9.5	Paved	335	0.019	2.0	2995	6	5.8	17	3.39	4.94	6.84	8.50	79.7	116.0	160.7	199.6
1b1	Prop. Storm Drain	B1	1.57	0.91	Bermudagrass	0.41	3.96	30	0.02	7.5	Paved	715	0.014	5.0	0	6	0.0	13	3.84	5.66	7.89	9.85	5.5	8.1	11.3	14.1
1b2	Prop. Storm Drain	B1-B2	2.46	0.86	Bermudagrass	0.41	3.96	30	0.02	7.5	Paved	715	0.014	5.0	155	6	0.4	13	3.84	5.66	7.89	9.85	8.1	12.0	16.7	20.8
1c	Prop. Storm Drain	C1	1.90	0.75	Bermudagrass	0.41	3.96	20	0.02	5.4	Unpaved	70	0.02	0.5	250	6	0.7	7	4.78	7.11	9.95	12.49	6.8	10.1	14.2	17.8
1	Exist. TxDOT Culvert "A1"	A1-A4, B1-B2, C1	33.65	0.86	Bermudagrass	0.41	3.96	40	0.02	9.5	Paved	335	0.019	2.0	2990	6	6.6	18	3.30	4.80	6.63	8.24	95.5	138.9	191.9	238.5
2	Exist. 4-way Inlet	D1-D2	3.02	0.87	Bermudagrass	0.41	3.96	30	0.02	7.5	Paved	465	0.05	1.7	450	6	1.3	11	4.10	6.08	8.50	10.64	12.9	19.1	26.8	33.5

PREVIOUSLY APPROVED DESIGN

Area (acres)	Q ₁₅ (cfs)	Q ₃₀ (cfs)
-	-	-
-	-	-
-	-	-
46.1	205	239
3.99	27.0	35.7

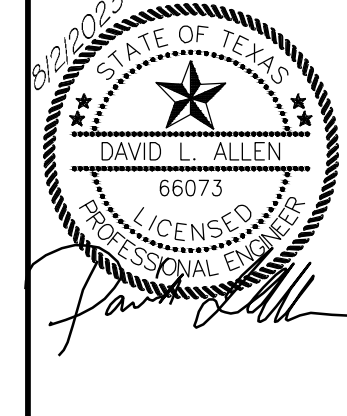
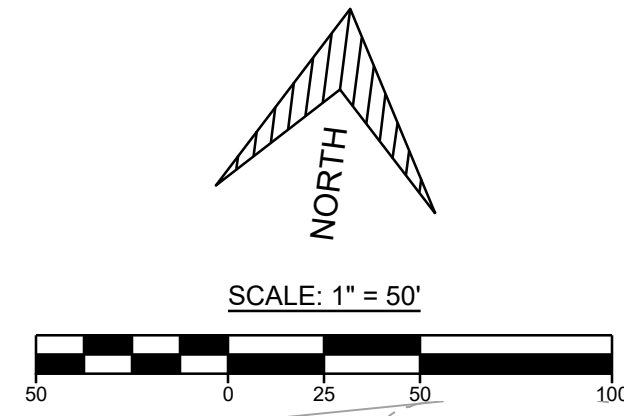

*Ref. weighted runoff coefficient calculations

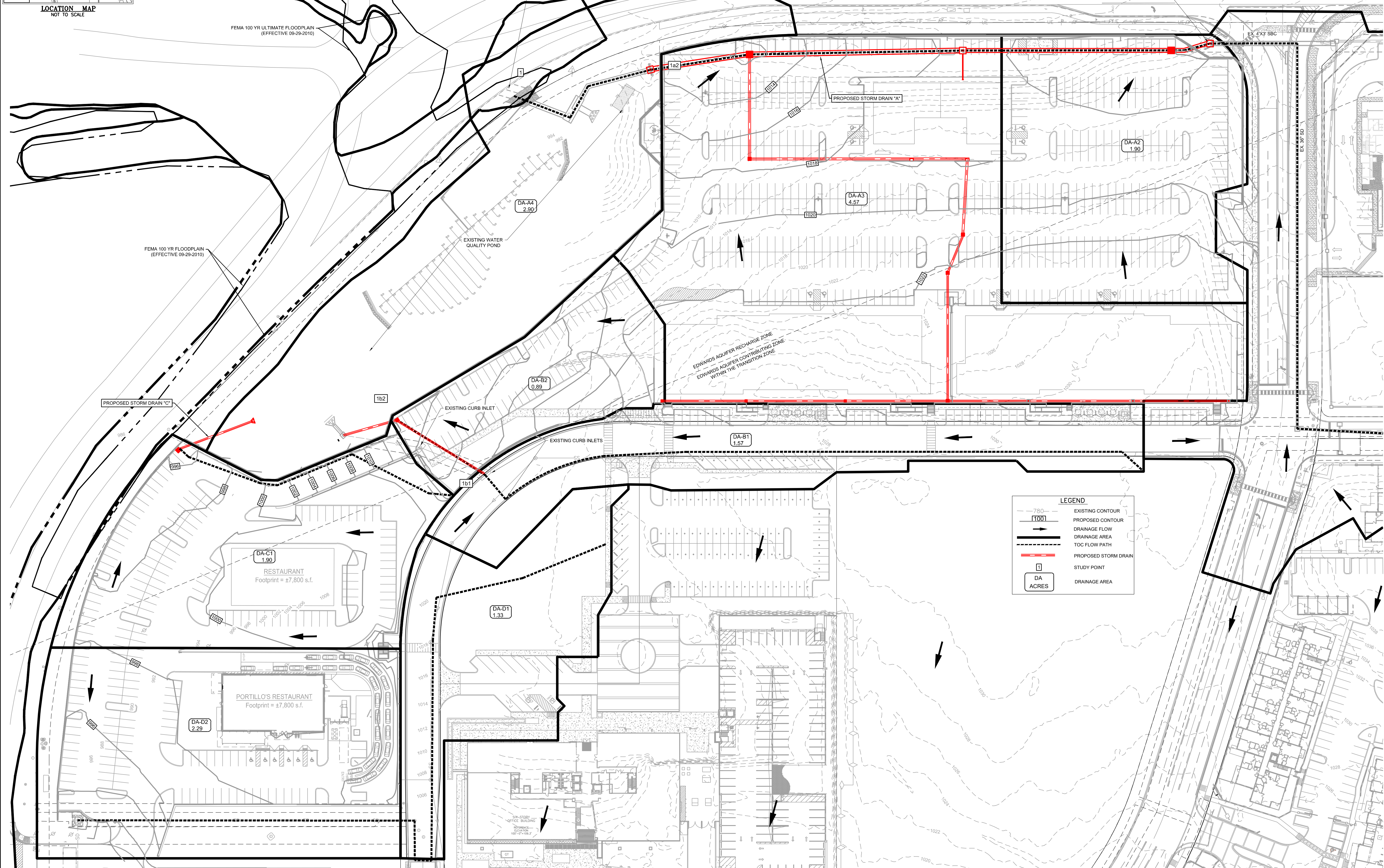

LEGEND

- - - - - EXISTING CONTOUR
- — — — — PROPOSED CONTOUR
- DRAINAGE FLOW
- ▭ DRAINAGE AREA
- — — — — TOC FLOW PATH
- — — — — PROPOSED STORM DRAIN
- STUDY POINT
- ▭ DA ACRES
- ▭ DRAINAGE AREA

PRIMARY CONTACT: RICHARD HENDRIX, P.E.

MACINA • BOSE • COPELAND & ASSOC., INC.
 CONSULTING ENGINEERS AND LAND SURVEYORS
 1035 Central Parkway North, San Antonio, Texas 78232
 (210) 545-1122 Fax (210) 545-9302 www.mbcengineers.com
 FIRM REGISTRATION NUMBER: T.B.P.E. F-784 & T.B.P.L.S. 10011700

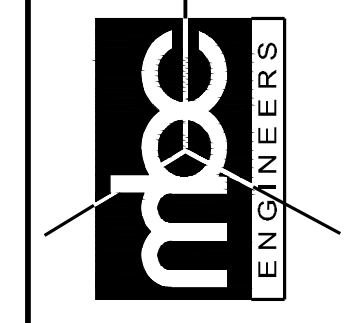

**LANDMARK NORTH & WEST
 SAN ANTONIO, TEXAS
 PROPOSED/ULTIMATE CONDITIONS
 DRAINAGE AREA MAP**

REVISIONS:	DATE	DESCRIPTION

PLAT ID#	APR	DESIGN	DRAWN	CHECKED	DATE	JOB NO.

Date: Aug 02, 2023, 8:02am User: r.hendrix Layout: DAM File: P:\076\03071-Fulcrum\landmark\Design\30371.dwg Layout name: DAM

- **Agent Authorization Form (TCEQ-0599), if application submitted by agent**

Agent Authorization Form
For Required Signature
Edwards Aquifer Protection Program
Relating to 30 TAC Chapter 213
Effective June 1, 1999

I Benjamin Dreszer,
Print Name

Partner,
Title - Owner/President/Other

of I.H. 10/ Loop 1604 Partners, LTD.,
Corporation/Partnership/Entity Name

have authorized Richard W. Hendrix, P.E.
Print Name of Agent/Engineer

of MBC Engineers, Inc.
Print Name of Firm

to represent and act on the behalf of the above named Corporation, Partnership, or Entity for the purpose of preparing and submitting this plan application to the Texas Commission on Environmental Quality (TCEQ) for the review and approval consideration of regulated activities.

I also understand that:

1. The applicant is responsible for compliance with 30 Texas Administrative Code Chapter 213 and any condition of the TCEQ's approval letter. The TCEQ is authorized to assess administrative penalties of up to \$10,000 per day per violation.
2. For those submitting an application who are not the property owner, but who have the right to control and possess the property, additional authorization is required from the owner.
3. Application fees are due and payable at the time the application is submitted. The application fee must be sent to the TCEQ cashier or to the appropriate regional office. The application will not be considered until the correct fee is received by the commission.
4. A notarized copy of the Agent Authorization Form must be provided for the person preparing the application, and this form must accompany the completed application.
5. No person shall commence any regulated activity on the Edwards Aquifer Recharge Zone, Contributing Zone or Transition Zone until the appropriate application for the activity has been filed with and approved by the Executive Director.

SIGNATURE PAGE:

[Handwritten Signature]
Applicant's Signature

7/27/28
Date

THE STATE OF Texas §

County of Bexar §

BEFORE ME, the undersigned authority, on this day personally appeared Benjamin Dresler known to me to be the person whose name is subscribed to the foregoing instrument, and acknowledged to me that (s)he executed same for the purpose and consideration therein expressed.

GIVEN under my hand and seal of office on this 27th day of July 2023

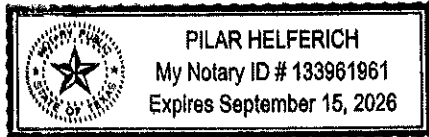

[Handwritten Signature]
NOTARY PUBLIC

PILAR HELFERICH
Typed or Printed Name of Notary

MY COMMISSION EXPIRES: 9/15/2026

- **Application Fee Form (TCEQ-0574)**
- **Check Payable to the “Texas Commission on Environmental Quality”**

Application Fee Form

Texas Commission on Environmental Quality

Name of Proposed Regulated Entity: Landmark North-West

Regulated Entity Location: Southeast corner of Loop 1604 & I.H. 10

Name of Customer: IH10/Loop 1604 Partners, LTD.

Contact Person: Benjamin Dreszer

Phone: (210) 593-0777

Customer Reference Number (if issued): CN 603349507

Regulated Entity Reference Number (if issued): RN 106376296

Austin Regional Office (3373)

Hays

Travis

Williamson

San Antonio Regional Office (3362)

Bexar

Medina

Uvalde

Comal

Kinney

Application fees must be paid by check, certified check, or money order, payable to the **Texas Commission on Environmental Quality**. Your canceled check will serve as your receipt. **This form must be submitted with your fee payment.** This payment is being submitted to:

Austin Regional Office

San Antonio Regional Office

Mailed to: TCEQ - Cashier

Overnight Delivery to: TCEQ - Cashier

Revenues Section

12100 Park 35 Circle

Mail Code 214

Building A, 3rd Floor

P.O. Box 13088

Austin, TX 78753

Austin, TX 78711-3088

(512)239-0357

Site Location (Check All That Apply):

Recharge Zone

Contributing Zone

Transition Zone

Type of Plan	Size	Fee Due
Water Pollution Abatement Plan, Contributing Zone Plan: One Single Family Residential Dwelling	Acres	\$
Water Pollution Abatement Plan, Contributing Zone Plan: Multiple Single Family Residential and Parks	Acres	\$
Water Pollution Abatement Plan, Contributing Zone Plan: Non-residential	Acres	\$
Sewage Collection System	930 L.F.	\$ 650.00
Lift Stations without sewer lines	Acres	\$
Underground or Aboveground Storage Tank Facility	Tanks	\$
Piping System(s)(only)	Each	\$
Exception	Each	\$
Extension of Time	Each	\$

Signature: 

Date: 10/19/2023

Application Fee Schedule

Texas Commission on Environmental Quality

Edwards Aquifer Protection Program 30 TAC Chapter 213 (effective 05/01/2008)

Water Pollution Abatement Plans and Modifications

Contributing Zone Plans and Modifications

<i>Project</i>	<i>Project Area in Acres</i>	<i>Fee</i>
One Single Family Residential Dwelling	< 5	\$650
Multiple Single Family Residential and Parks	< 5	\$1,500
	5 < 10	\$3,000
	10 < 40	\$4,000
	40 < 100	\$6,500
	100 < 500	\$8,000
	≥ 500	\$10,000
Non-residential (Commercial, industrial, institutional, multi-family residential, schools, and other sites where regulated activities will occur)	< 1	\$3,000
	1 < 5	\$4,000
	5 < 10	\$5,000
	10 < 40	\$6,500
	40 < 100	\$8,000
	≥ 100	\$10,000

Organized Sewage Collection Systems and Modifications

<i>Project</i>	<i>Cost per Linear Foot</i>	<i>Minimum Fee- Maximum Fee</i>
Sewage Collection Systems	\$0.50	\$650 - \$6,500

Underground and Aboveground Storage Tank System Facility Plans and Modifications

<i>Project</i>	<i>Cost per Tank or Piping System</i>	<i>Minimum Fee- Maximum Fee</i>
Underground and Aboveground Storage Tank Facility	\$650	\$650 - \$6,500

Exception Requests

<i>Project</i>	<i>Fee</i>
Exception Request	\$500

Extension of Time Requests

<i>Project</i>	<i>Fee</i>
Extension of Time Request	\$150

– **Core Data Form (TCEQ-10400)**



TCEQ Core Data Form

For detailed instructions on completing this form, please read the Core Data Form Instructions or call 512-239-5175.

SECTION I: General Information

1. Reason for Submission (If other is checked please describe in space provided.)		
<input type="checkbox"/> New Permit, Registration or Authorization (Core Data Form should be submitted with the program application.)		
<input type="checkbox"/> Renewal (Core Data Form should be submitted with the renewal form)		<input checked="" type="checkbox"/> Other SCS / Lift Station
2. Customer Reference Number (if issued)	Follow this link to search for CN or RN numbers in Central Registry**	3. Regulated Entity Reference Number (if issued)
CN 603349507		RN 106376296

SECTION II: Customer Information

4. General Customer Information		5. Effective Date for Customer Information Updates (mm/dd/yyyy)	
<input type="checkbox"/> New Customer <input checked="" type="checkbox"/> Update to Customer Information <input type="checkbox"/> Change in Regulated Entity Ownership <input type="checkbox"/> Change in Legal Name (Verifiable with the Texas Secretary of State or Texas Comptroller of Public Accounts)			
<i>The Customer Name submitted here may be updated automatically based on what is current and active with the Texas Secretary of State (SOS) or Texas Comptroller of Public Accounts (CPA).</i>			
6. Customer Legal Name (If an individual, print last name first: eg: Doe, John)		<i>If new Customer, enter previous Customer below:</i>	
IH 10/Loop 1604 Partners, LTD			
7. TX SOS/CPA Filing Number	8. TX State Tax ID (11 digits)	9. Federal Tax ID (9 digits)	10. DUNS Number (if applicable)
		260437282	
11. Type of Customer:	<input checked="" type="checkbox"/> Corporation	<input type="checkbox"/> Individual	Partnership: <input type="checkbox"/> General <input type="checkbox"/> Limited
Government: <input type="checkbox"/> City <input type="checkbox"/> County <input type="checkbox"/> Federal <input type="checkbox"/> Local <input type="checkbox"/> State <input type="checkbox"/> Other	<input type="checkbox"/> Sole Proprietorship	<input type="checkbox"/> Other:	
12. Number of Employees		13. Independently Owned and Operated?	
<input checked="" type="checkbox"/> 0-20 <input type="checkbox"/> 21-100 <input type="checkbox"/> 101-250 <input type="checkbox"/> 251-500 <input type="checkbox"/> 501 and higher		<input checked="" type="checkbox"/> Yes <input type="checkbox"/> No	
14. Customer Role (Proposed or Actual) – as it relates to the Regulated Entity listed on this form. Please check one of the following			
<input type="checkbox"/> Owner <input type="checkbox"/> Operator <input checked="" type="checkbox"/> Owner & Operator <input type="checkbox"/> Other: <input type="checkbox"/> Occupational Licensee <input type="checkbox"/> Responsible Party <input type="checkbox"/> VCP/BSA Applicant			
15. Mailing Address:	10003 NW Military Hwy, Suite 2205		
City	San Antonio	State	TX
ZIP	78231	ZIP + 4	1890
16. Country Mailing Information (if outside USA)		17. E-Mail Address (if applicable)	
18. Telephone Number	19. Extension or Code	20. Fax Number (if applicable)	

SECTION III: Regulated Entity Information**21. General Regulated Entity Information** (If "New Regulated Entity" is selected, a new permit application is also required.)

New Regulated Entity Update to Regulated Entity Name Update to Regulated Entity Information

The Regulated Entity Name submitted may be updated, in order to meet TCEQ Core Data Standards (removal of organizational endings such as Inc, LP, or LLC).

22. Regulated Entity Name (Enter name of the site where the regulated action is taking place.)

Landmark North-West

23. Street Address of the Regulated Entity:(No PO Boxes)

City	San Antonio	State	TX	ZIP	78249	ZIP + 4	
-------------	-------------	--------------	----	------------	-------	----------------	--

24. County

Bexar

If no Street Address is provided, fields 25-28 are required.

25. Description to**Physical Location:**

Southeast corner of the intersection of Loop 1604 and IH 10

26. Nearest City**State****Nearest ZIP Code**

San Antonio

TX

78249

Latitude/Longitude are required and may be added/updated to meet TCEQ Core Data Standards. (Geocoding of the Physical Address may be used to supply coordinates where none have been provided or to gain accuracy).

27. Latitude (N) In Decimal:

29.587977

28. Longitude (W) In Decimal:

-98.593959

Degrees

Minutes

Seconds

Degrees

Minutes

Seconds

29

35

16.7166

-98

35

38.2518

29. Primary SIC Code**30. Secondary SIC Code****31. Primary NAICS Code****32. Secondary NAICS Code**

(4 digits)

(4 digits)

(5 or 6 digits)

(5 or 6 digits)

8748

531120

33. What is the Primary Business of this entity? (Do not repeat the SIC or NAICS description.)

Commercial retail business

34. Mailing

10003 NW Military Hwy, Suite 2205

Address:

City	San Antonio	State	TX	ZIP	78231	ZIP + 4	1890
-------------	-------------	--------------	----	------------	-------	----------------	------

35. E-Mail Address:

benjamin@fulcrumsa.com

36. Telephone Number**37. Extension or Code****38. Fax Number** (if applicable)

(210) 593-777

() -

39. TCEQ Programs and ID Numbers Check all Programs and write in the permits/registration numbers that will be affected by the updates submitted on this form. See the Core Data Form instructions for additional guidance.

<input type="checkbox"/> Dam Safety	<input type="checkbox"/> Districts	<input checked="" type="checkbox"/> Edwards Aquifer	<input type="checkbox"/> Emissions Inventory Air	<input type="checkbox"/> Industrial Hazardous Waste
<input type="checkbox"/> Municipal Solid Waste	<input type="checkbox"/> New Source Review Air	<input type="checkbox"/> OSSF	<input type="checkbox"/> Petroleum Storage Tank	<input type="checkbox"/> PWS
<input type="checkbox"/> Sludge	<input type="checkbox"/> Storm Water	<input type="checkbox"/> Title V Air	<input type="checkbox"/> Tires	<input type="checkbox"/> Used Oil
<input type="checkbox"/> Voluntary Cleanup	<input checked="" type="checkbox"/> Wastewater	<input type="checkbox"/> Wastewater Agriculture	<input type="checkbox"/> Water Rights	<input type="checkbox"/> Other:

SECTION IV: Preparer Information

40. Name:	Richard Hendrix	41. Title:	Project Manager
42. Telephone Number	43. Ext./Code	44. Fax Number	45. E-Mail Address
(210) 545-1122		(210) 545-9302	rhendrix@mbcengineers.com

SECTION V: Authorized Signature

46. By my signature below, I certify, to the best of my knowledge, that the information provided in this form is true and complete, and that I have signature authority to submit this form on behalf of the entity specified in Section II, Field 6 and/or as required for the updates to the ID numbers identified in field 39.

Company:	MBC Engineers	Job Title:	Project Manager
Name (In Print):	Richard Hendrix	Phone:	(210) 545- 1122
Signature:		Date:	10/19/2023