

# **ORGANIZED SEWER COLLECTION SYSTEM**

**ESTANCIA RANCH, UNIT 3**

**PREPARED FOR**

MERITAGE HOMES OF TEXAS, LLC

*NOVEMBER 2023*



*ESTANCIA RANCH*  
*UNIT 3*

ORGANIZED SEWAGE COLLECTION SYSTEM (SCS)

**PREPARED FOR:**

MERITAGE HOMES OF TEXAS, LLC  
2722 W. BITTERS ROAD, SUITE 200  
SAN ANTONIO, TX 78248

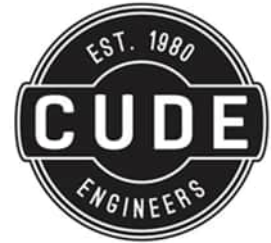

September 20, 2023

Texas Commission on Environmental Quality – San Antonio Region  
14250 Judson Rd.  
San Antonio, TX 78233-4480

Re: Estancia Ranch, Unit 3  
Organized Sewage Collection System Application

To Whom It May Concern:

Please find the attached original (1) and one (1) copy of the Estancia Ranch, Unit 3 Organized Sewage Collection System Plan application submittal. This application has been prepared to be consistent with the Texas Commission on Environmental Quality (30 TAC 213) and its current policies for development over the Edwards Aquifer Recharge Zone.

The appropriate review fee in the amount of \$650.00 is included herein. If you should have any questions regarding the contained information, please do not hesitate to contact our office.

Sincerely,

A handwritten signature in blue ink, appearing to read "A. Lowry", is positioned above the printed name.

Andrew R. Lowry, P.E.  
Associate

# Organized Sewage Collection System Plan Checklist

- **Edwards Aquifer Application Cover Page (TCEQ-20705)**
- **General Information Form (TCEQ-0587)**
  - Attachment A - Road Map
  - Attachment B - USGS / Edwards Recharge Zone Map
  - Attachment C - Project Description
- **Geologic Assessment Form (TCEQ-0585)**
  - Attachment A - Geologic Assessment Table (TCEQ-0585-Table)
  - Attachment B - Stratigraphic Column
  - Attachment C - Site Geology
  - Attachment D - Site Geologic Map(s)
- **Organized Sewage Collection System Plan (TCEQ-0582)**
  - Attachment A - SCS Engineering Design Report
  - Attachment B - Justification and Calculations for Deviation in Straight Alignment Without Manholes
  - Attachment C - Justification for Variance from Maximum Manhole Spacing
  - Attachment D – Calculations for Slopes for Flows Greater Than 10.0 Feet Per Second Site Plan
  - Final Plan and Profile Sheets
- **Lift Station / Force Main System Application (TCEQ-0624) if applicable**
  - Attachment A - Engineering Design Report
  - Site Plan
  - Final Plan and Profile Sheets
- **Temporary Stormwater Section (TCEQ-0602)**
  - Attachment A - Spill Response Actions
  - Attachment B - Potential Sources of Contamination
  - Attachment C - Sequence of Major Activities
  - Attachment D - Temporary Best Management Practices and Measures
  - Attachment E - Request to Temporarily Seal a Feature (if requested)
  - Attachment F - Structural Practices
  - Attachment G - Drainage Area Map
  - Attachment H - Temporary Sediment Pond(s) Plans and Calculations
  - Attachment I - Inspection and Maintenance for BMPs
  - Attachment J - Schedule of Interim and Permanent Soil Stabilization Practices
- **Agent Authorization Form (TCEQ-0599), if application submitted by agent**
- **Application Fee Form (TCEQ-0574)**

- **Check Payable to the “Texas Commission on Environmental Quality”**
- **Core Data Form (TCEQ-10400)**

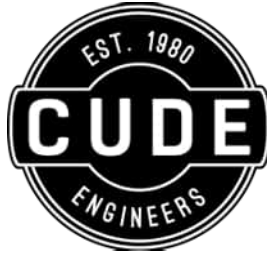

## ESTANCIA RANCH, UNIT 3

### *EDWARDS AQUIFER APPLICATION COVER PAGE (TCEQ-20705)*

# Texas Commission on Environmental Quality

## Edwards Aquifer Application Cover Page

---

### Our Review of Your Application

**The Edwards Aquifer Program staff conducts an administrative and technical review of all applications. The turnaround time for administrative review can be up to 30 days as outlined in 30 TAC 213.4(e). Generally administrative completeness is determined during the intake meeting or within a few days of receipt. The turnaround time for technical review of an administratively complete Edwards Aquifer application is 90 days as outlined in 30 TAC 213.4(e). Please know that the review and approval time is directly impacted by the quality and completeness of the initial application that is received. In order to conduct a timely review, it is imperative that the information provided in an Edwards Aquifer application include final plans, be accurate, complete, and in compliance with [30 TAC 213](#).**

### Administrative Review

1. [Edwards Aquifer applications](#) must be deemed administratively complete before a technical review can begin. To be considered administratively complete, the application must contain completed forms and attachments, provide the requested information, and meet all the site plan requirements. The submitted application and plan sheets should be final plans. Please submit one full-size set of plan sheets with the original application, and half-size sets with the additional copies.

To ensure that all applicable documents are included in the application, the program has developed tools to guide you and web pages to provide all forms, checklists, and guidance. Please visit the below website for assistance: <http://www.tceq.texas.gov/field/eapp>.

2. This Edwards Aquifer Application Cover Page form (certified by the applicant or agent) must be included in the application and brought to the administrative review meeting.
3. Administrative reviews are scheduled with program staff who will conduct the review. Applicants or their authorized agent should call the appropriate regional office, according to the county in which the project is located, to schedule a review. The average meeting time is one hour.
4. In the meeting, the application is examined for administrative completeness. Deficiencies will be noted by staff and emailed or faxed to the applicant and authorized agent at the end of the meeting, or shortly after. Administrative deficiencies will cause the application to be deemed incomplete and returned.

An appointment should be made to resubmit the application. The application is re-examined to ensure all deficiencies are resolved. The application will only be deemed administratively complete when all administrative deficiencies are addressed.

5. If an application is received by mail, courier service, or otherwise submitted without a review meeting, the administrative review will be conducted within 30 days. The applicant and agent will be contacted with the results of the administrative review. If the application is found to be administratively incomplete, it can be retrieved from the regional office or returned by regular mail. If returned by mail, the regional office may require arrangements for return shipping.
6. If the geologic assessment was completed before October 1, 2004 and the site contains “possibly sensitive” features, the assessment must be updated in accordance with the *Instructions to Geologists* (TCEQ-0585 Instructions).

### Technical Review

1. When an application is deemed administratively complete, the technical review period begins. The regional office will distribute copies of the application to the identified affected city, county, and groundwater conservation district whose jurisdiction includes the subject site. These entities and the public have 30 days to provide comments on the application to the regional office. All comments received are reviewed by TCEQ.
2. A site assessment is usually conducted as part of the technical review, to evaluate the geologic assessment and observe existing site conditions. The site must be accessible to our staff. The site boundaries should be

clearly marked, features identified in the geologic assessment should be flagged, roadways marked and the alignment of the Sewage Collection System and manholes should be staked at the time the application is submitted. If the site is not marked the application may be returned.

3. We evaluate the application for technical completeness and contact the applicant and agent via Notice of Deficiency (NOD) to request additional information and identify technical deficiencies. There are two deficiency response periods available to the applicant. There are 14 days to resolve deficiencies noted in the first NOD. If a second NOD is issued, there is an additional 14 days to resolve deficiencies. If the response to the second notice is not received, is incomplete or inadequate, or provides new information that is incomplete or inadequate, the application must be withdrawn or will be denied. Please note that because the technical review is underway, whether the application is withdrawn or denied **the application fee will be forfeited**.
4. The program has 90 calendar days to complete the technical review of the application. If the application is technically adequate, such that it complies with the Edwards Aquifer rules, and is protective of the Edwards Aquifer during and after construction, an approval letter will be issued. Construction or other regulated activity may not begin until an approval is issued.

**Mid-Review Modifications**

It is important to have final site plans prior to beginning the permitting process with TCEQ to avoid delays.

Occasionally, circumstances arise where you may have significant design and/or site plan changes after your Edwards Aquifer application has been deemed administratively complete by TCEQ. This is considered a “Mid-Review Modification”. Mid-Review Modifications may require redistribution of an application that includes the proposed modifications for public comment.

If you are proposing a Mid-Review Modification, two options are available:

- If the technical review has begun your application can be denied/withdrawn, your fees will be forfeited, and the plan will have to be resubmitted.
- TCEQ can continue the technical review of the application as it was submitted, and a modification application can be submitted at a later time.

If the application is denied/withdrawn, the resubmitted application will be subject to the administrative and technical review processes and will be treated as a new application. The application will be redistributed to the affected jurisdictions.

Please contact the regional office if you have questions. If your project is located in Williamson, Travis, or Hays County, contact TCEQ’s Austin Regional Office at 512-339-2929. If your project is in Comal, Bexar, Medina, Uvalde, or Kinney County, contact TCEQ’s San Antonio Regional Office at 210-490-3096

Please fill out all required fields below and submit with your application.

<b>1. Regulated Entity Name:</b> Estancia Ranch, Unit 3				<b>2. Regulated Entity No.:</b>					
<b>3. Customer Name:</b> Meritage Homes of Texas, LLC				<b>4. Customer No.:</b> 603298068					
<b>5. Project Type:</b> (Please circle/check one)	New		Modification			Extension		Exception	
<b>6. Plan Type:</b> (Please circle/check one)	WPAP	CZP	SCS	UST	AST	EXP	EXT	Technical Clarification	Optional Enhanced Measures
<b>7. Land Use:</b> (Please circle/check one)	Residential		Non-residential			<b>8. Site (acres):</b>		65.64	
<b>9. Application Fee:</b>	\$1,353.36		<b>10. Permanent BMP(s):</b>			N/A			
<b>11. SCS (Linear Ft.):</b>	2,706.71		<b>12. AST/UST (No. Tanks):</b>			N/A			
<b>13. County:</b>	Bexar		<b>14. Watershed:</b>			Cibolo Creek			



# Application Distribution

Instructions: Use the table below to determine the number of applications required. One original and one copy of the application, plus additional copies (as needed) for each affected incorporated city, county, and groundwater conservation district are required. Linear projects or large projects, which cross into multiple jurisdictions, can require additional copies. Refer to the “Texas Groundwater Conservation Districts within the EAPP Boundaries” map found at:

[http://www.tceq.texas.gov/assets/public/compliance/field\\_ops/eapp/EAPP%20GWCD%20map.pdf](http://www.tceq.texas.gov/assets/public/compliance/field_ops/eapp/EAPP%20GWCD%20map.pdf)

For more detailed boundaries, please contact the conservation district directly.

<b>Austin Region</b>			
<b>County:</b>	<b>Hays</b>	<b>Travis</b>	<b>Williamson</b>
Original (1 req.)	—	—	—
Region (1 req.)	—	—	—
County(ies)	—	—	—
Groundwater Conservation District(s)	<input type="checkbox"/> Edwards Aquifer Authority <input type="checkbox"/> Barton Springs/ Edwards Aquifer <input type="checkbox"/> Hays Trinity <input type="checkbox"/> Plum Creek	<input type="checkbox"/> Barton Springs/ Edwards Aquifer	NA
City(ies) Jurisdiction	<input type="checkbox"/> Austin <input type="checkbox"/> Buda <input type="checkbox"/> Dripping Springs <input type="checkbox"/> Kyle <input type="checkbox"/> Mountain City <input type="checkbox"/> San Marcos <input type="checkbox"/> Wimberley <input type="checkbox"/> Woodcreek	<input type="checkbox"/> Austin <input type="checkbox"/> Bee Cave <input type="checkbox"/> Pflugerville <input type="checkbox"/> Rollingwood <input type="checkbox"/> Round Rock <input type="checkbox"/> Sunset Valley <input type="checkbox"/> West Lake Hills	<input type="checkbox"/> Austin <input type="checkbox"/> Cedar Park <input type="checkbox"/> Florence <input type="checkbox"/> Georgetown <input type="checkbox"/> Jerrell <input type="checkbox"/> Leander <input type="checkbox"/> Liberty Hill <input type="checkbox"/> Pflugerville <input type="checkbox"/> Round Rock

<b>San Antonio Region</b>					
<b>County:</b>	<b>Bexar</b>	<b>Comal</b>	<b>Kinney</b>	<b>Medina</b>	<b>Uvalde</b>
Original (1 req.)	✓	—	—	—	—
Region (1 req.)	✓	—	—	—	—
County(ies)	✓	—	—	—	—
Groundwater Conservation District(s)	<input checked="" type="checkbox"/> Edwards Aquifer Authority <input type="checkbox"/> Trinity-Glen Rose	<input type="checkbox"/> Edwards Aquifer Authority	<input type="checkbox"/> Kinney	<input type="checkbox"/> EAA <input type="checkbox"/> Medina	<input type="checkbox"/> EAA <input type="checkbox"/> Uvalde
City(ies) Jurisdiction	<input type="checkbox"/> Castle Hills <input type="checkbox"/> Fair Oaks Ranch <input type="checkbox"/> Helotes <input type="checkbox"/> Hill Country Village <input type="checkbox"/> Hollywood Park <input checked="" type="checkbox"/> San Antonio (SAWS) <input type="checkbox"/> Shavano Park	<input type="checkbox"/> Bulverde <input type="checkbox"/> Fair Oaks Ranch <input type="checkbox"/> Garden Ridge <input type="checkbox"/> New Braunfels <input type="checkbox"/> Schertz	NA	<input type="checkbox"/> San Antonio ETJ (SAWS)	NA

I certify that to the best of my knowledge, that the application is complete and accurate. This application is hereby submitted to TCEQ for administrative review and technical review.

Andrew R. Lowry, P.E.

Print Name of Customer/Authorized Agent

10/30/23

Signature of Customer/Authorized Agent

Date

**\*\*FOR TCEQ INTERNAL USE ONLY\*\***

Date(s) Reviewed:		Date Administratively Complete:	
Received From:		Correct Number of Copies:	
Received By:		Distribution Date:	
EAPP File Number:		Complex:	
Admin. Review(s) (No.):		No. AR Rounds:	
Delinquent Fees (Y/N):		Review Time Spent:	
Lat./Long. Verified:		SOS Customer Verification:	
Agent Authorization Complete/Notarized (Y/N):		Fee Check:	Payable to TCEQ (Y/N):
Core Data Form Complete (Y/N):			Signed (Y/N):
Core Data Form Incomplete Nos.:			Less than 90 days old (Y/N):

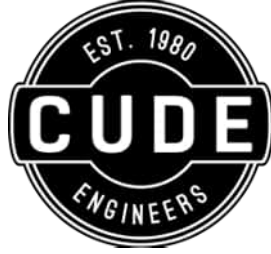

## ESTANCIA RANCH, UNIT 3

### *GENERAL INFORMATION SECTION (TCEQ-0587)*

# General Information Form

## Texas Commission on Environmental Quality

For Regulated Activities on the Edwards Aquifer Recharge and Transition Zones and Relating to 30 TAC §213.4(b) & §213.5(b)(2)(A), (B) Effective June 1, 1999

**To ensure that the application is administratively complete, confirm that all fields in the form are complete, verify that all requested information is provided, consistently reference the same site and contact person in all forms in the application, and ensure forms are signed by the appropriate party.**

**Note: Including all the information requested in the form and attachments contributes to more streamlined technical reviews.**

## Signature

To the best of my knowledge, the responses to this form accurately reflect all information requested concerning the proposed regulated activities and methods to protect the Edwards Aquifer. This **General Information Form** is hereby submitted for TCEQ review. The application was prepared by:

Print Name of Customer/Agent: Andrew R. Lowry, P.E.

Date: 9/20/2023

Signature of Customer/Agent:

 10/30/23

## Project Information

1. Regulated Entity Name: Estancia Ranch, Unit 3
2. County: Bexar
3. Stream Basin: Cibolo Creek
4. Groundwater Conservation District (If applicable): Edwards Aquifer
5. Edwards Aquifer Zone:
  - Recharge Zone
  - Transition Zone
6. Plan Type:
  - WPAP
  - SCS
  - Modification
  - AST
  - UST
  - Exception Request

7. Customer (Applicant):

Contact Person: Brian Otto

Entity: Meritage Homes of Texas, L.L.C.

Mailing Address: 2722 W. Bitters Rd., Suite 200

City, State: San Antonio, TX

Telephone: 210-260-6069

Email Address: brian.otto@meritagehomes.com

Zip: 78248

FAX: \_\_\_\_\_

8. Agent/Representative (If any):

Contact Person: Andrew R. Lowry, P.E.

Entity: Cude Engineers

Mailing Address: 4122 Pond Hill Rd., Suite 101

City, State: San Antonio, TX

Telephone: 210-681-2951

Email Address: alowry@cudeengineers.com

Zip: 78231

FAX: 210-523-7112

9. Project Location:

The project site is located inside the city limits of \_\_\_\_\_.

The project site is located outside the city limits but inside the ETJ (extra-territorial jurisdiction) of the City of San Antonio.

The project site is not located within any city's limits or ETJ.

10.  The location of the project site is described below. The description provides sufficient detail and clarity so that the TCEQ's Regional staff can easily locate the project and site boundaries for a field investigation.

The proposed project Estancia Ranch is located in the northeast corner of the Blanco Rd. and Specht Rd. intersection.

11.  **Attachment A – Road Map.** A road map showing directions to and the location of the project site is attached. The project location and site boundaries are clearly shown on the map.

12.  **Attachment B - USGS / Edwards Recharge Zone Map.** A copy of the official 7 ½ minute USGS Quadrangle Map (Scale: 1" = 2000') of the Edwards Recharge Zone is attached. The map(s) clearly show:

Project site boundaries.

USGS Quadrangle Name(s).

Boundaries of the Recharge Zone (and Transition Zone, if applicable).

Drainage path from the project site to the boundary of the Recharge Zone.

13.  **The TCEQ must be able to inspect the project site or the application will be returned.** Sufficient survey staking is provided on the project to allow TCEQ regional staff to locate the boundaries and alignment of the regulated activities and the geologic or manmade features noted in the Geologic Assessment.

Survey staking will be completed by this date: Upon TCEQ request.

14.  **Attachment C – Project Description.** Attached at the end of this form is a detailed narrative description of the proposed project. The project description is consistent throughout the application and contains, at a minimum, the following details:

- Area of the site
- Offsite areas
- Impervious cover
- Permanent BMP(s)
- Proposed site use
- Site history
- Previous development
- Area(s) to be demolished

15. Existing project site conditions are noted below:

- Existing commercial site
- Existing industrial site
- Existing residential site
- Existing paved and/or unpaved roads
- Undeveloped (Cleared)
- Undeveloped (Undisturbed/Uncleared)
- Other: \_\_\_\_\_

### ***Prohibited Activities***

16.  I am aware that the following activities are prohibited on the Recharge Zone and are not proposed for this project:

- (1) Waste disposal wells regulated under 30 TAC Chapter 331 of this title (relating to Underground Injection Control);
- (2) New feedlot/concentrated animal feeding operations, as defined in 30 TAC §213.3;
- (3) Land disposal of Class I wastes, as defined in 30 TAC §335.1;
- (4) The use of sewage holding tanks as parts of organized collection systems; and
- (5) New municipal solid waste landfill facilities required to meet and comply with Type I standards which are defined in §330.41(b), (c), and (d) of this title (relating to Types of Municipal Solid Waste Facilities).
- (6) New municipal and industrial wastewater discharges into or adjacent to water in the state that would create additional pollutant loading.

17.  I am aware that the following activities are prohibited on the Transition Zone and are not proposed for this project:

- (1) Waste disposal wells regulated under 30 TAC Chapter 331 (relating to Underground Injection Control);
- (2) Land disposal of Class I wastes, as defined in 30 TAC §335.1; and

- (3) New municipal solid waste landfill facilities required to meet and comply with Type I standards which are defined in §330.41 (b), (c), and (d) of this title.

### ***Administrative Information***

18. The fee for the plan(s) is based on:

- For a Water Pollution Abatement Plan or Modification, the total acreage of the site where regulated activities will occur.
  - For an Organized Sewage Collection System Plan or Modification, the total linear footage of all collection system lines.
  - For a UST Facility Plan or Modification or an AST Facility Plan or Modification, the total number of tanks or piping systems.
  - A request for an exception to any substantive portion of the regulations related to the protection of water quality.
  - A request for an extension to a previously approved plan.
19.  Application fees are due and payable at the time the application is filed. If the correct fee is not submitted, the TCEQ is not required to consider the application until the correct fee is submitted. Both the fee and the Edwards Aquifer Fee Form have been sent to the Commission's:
- TCEQ cashier
  - Austin Regional Office (for projects in Hays, Travis, and Williamson Counties)
  - San Antonio Regional Office (for projects in Bexar, Comal, Kinney, Medina, and Uvalde Counties)
20.  Submit one (1) original and one (1) copy of the application, plus additional copies as needed for each affected incorporated city, groundwater conservation district, and county in which the project will be located. The TCEQ will distribute the additional copies to these jurisdictions. The copies must be submitted to the appropriate regional office.
21.  No person shall commence any regulated activity until the Edwards Aquifer Protection Plan(s) for the activity has been filed with and approved by the Executive Director.

Estancia Ranch, Unit 3  
Organized Sewage Collection System Plan





**ATTACHMENT A – ROAD MAP**

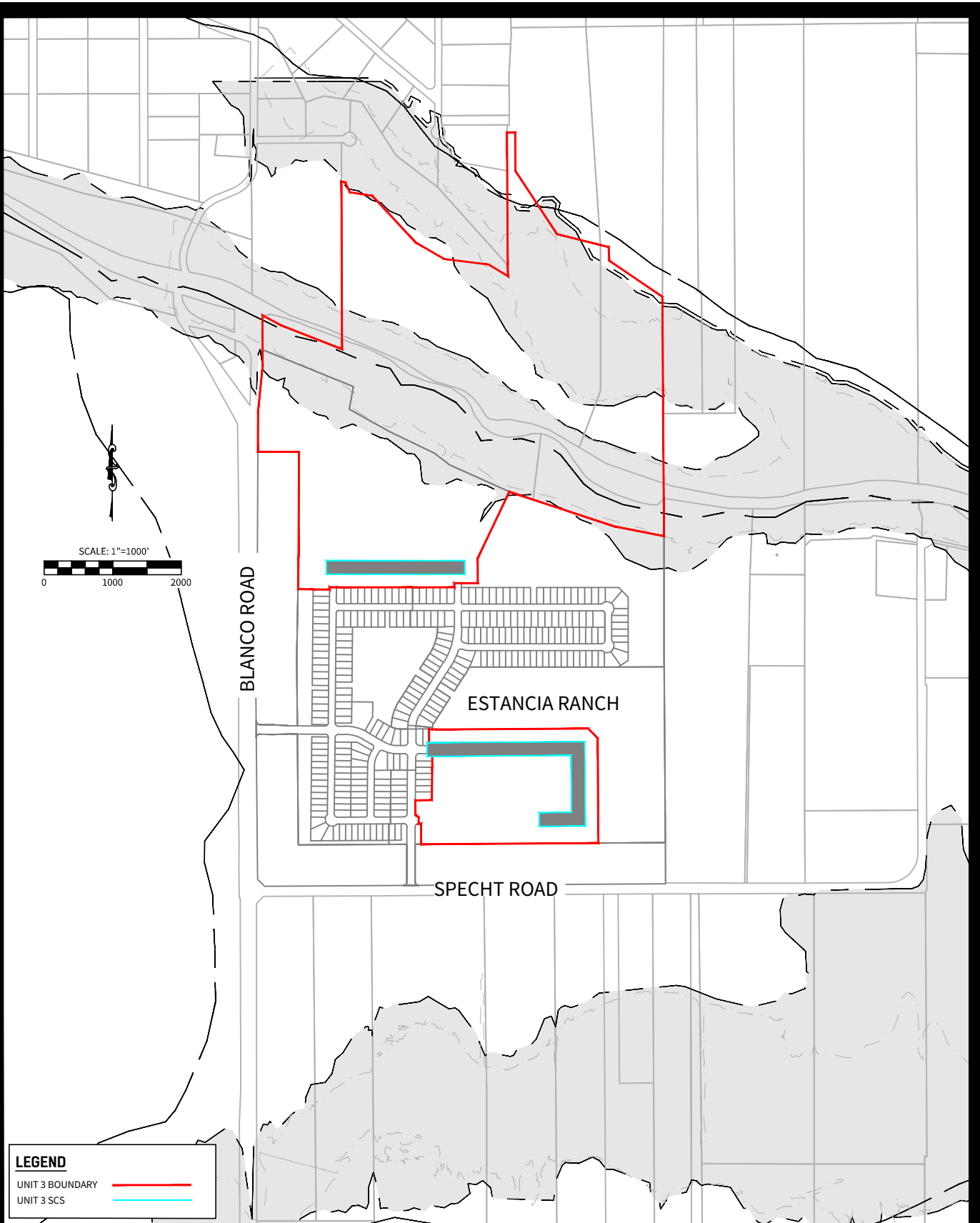

P:\03473\010\1-Document\Booklets\_SCS\_CAD\Road\_Map.dwg 2023/09/21 9:57am rtdiano



LEGEND	
UNIT 3 BOUNDARY	
UNIT 3 SCS	

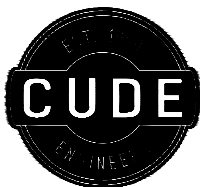

CUDE ENGINEERS  
 4122 POND HILL RD. • SUITE 101  
 SAN ANTONIO, TEXAS 78231  
 TEL 210.681.2951 • FAX 210.523.7112  
 WWW.CUDEENGINEERS.COM  
 TBPE REGISTERED ENGINEERING  
 FIRM #455

## ESTANCIA RANCH SUBDIVISION UNIT 3 SCS

ATTACHMENT A - ROAD MAP

DATE: 9/21/23

JOB NO.: 03473.010

REPRODUCTION OF THE ORIGINAL SIGNED AND SEALED PLAN AND/OR ELECTRONIC MEDIA MAY HAVE BEEN INADVERTENTLY ALTERED. CONTRACTOR IS RESPONSIBLE FOR VERIFYING THE SCALE OF THE DOCUMENT AND CONTACTING CUDE ENGINEERS TO VERIFY DISCREPANCIES PRIOR TO CONSTRUCTION.



## ATTACHMENT B – USGS / EDWARDS RECHARGE ZONE MAP

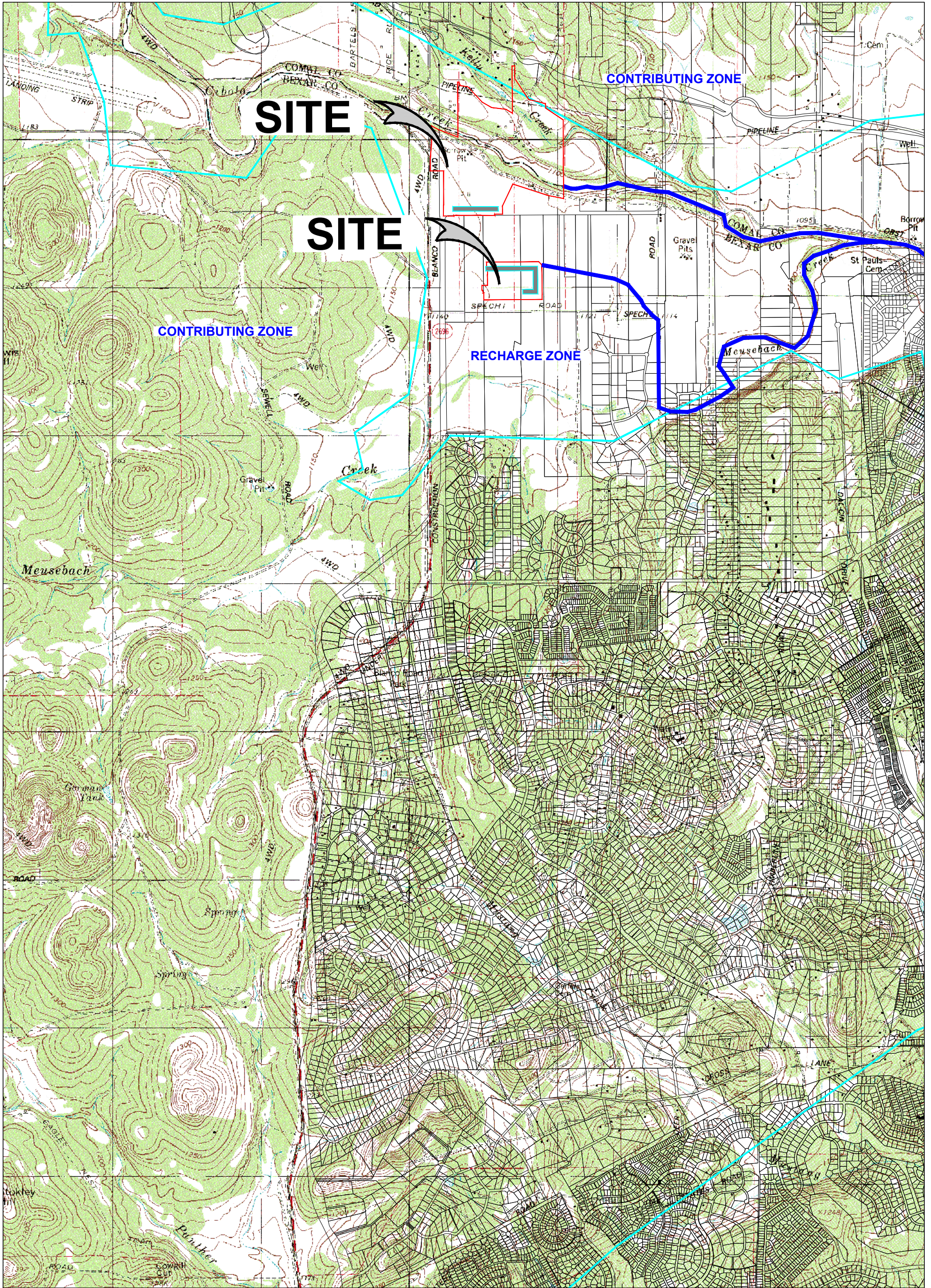

- UNIT 3 SCS
  - SITE BOUNDARY
  - CONTRIBUTING/RECHARGE ZONE LIMIT LINES
  - DRAINAGE FLOW PATH
- CAMP BULLIS NE QUADRANGLE  
 BULVERDE NW QUADRANGLE

SCALE: 1" = 2000'  
 USGS/EDWARDS RECHARGE ZONE MAP  
 ATTACHMENT B  
 SHEET 1 OF 1

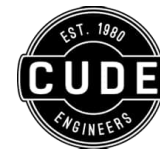

## ATTACHMENT C – PROJECT DESCRIPTION

The proposed ultimate single family residential development encompasses 271.88 acres of undeveloped land located in the northeast corner of Blanco Rd. and Specht Rd. intersection. This development will consist of the construction of 420 residential homes, street infrastructure, drainage facilities, gravity sewer infrastructure, water facilities and utility infrastructure. The site is located within City of San Antonio ETJ, Bexar County and Comal County, Texas. A portion of the site is located within the current limits of the DFIRM 1% annual chance floodplain. All of the site is located within the Edwards Aquifer Recharge Zone.

The proposed Unit 3 single family residential development encompasses 65.64 acres of undeveloped land. The Unit 3 development will consist of the construction of 152 residential homes, street infrastructure, drainage facilities, gravity sewer infrastructure, water facilities and utility infrastructure.

Access to the site will be provided along Blanco Rd. and Specht Rd. The site has access to existing utilities such as electric, sewer, and water service lines. The location of the existing improvements is shown on the boundary survey included in this report.

The subdivision will be platted through three subdivision units. This submittal is for the third unit and will be serviced by 2,706.71 linear feet of 8 in. diameter sanitary sewer SDR 26 PVC pipe. The sanitary sewer provider as well as the water purveyor for this site will be San Antonio Water System (SAWS). The Dos Rios Water Recycling Center will ultimately receive this site's wastewater for treatment and disposal. A Water Pollution Abatement Plan has been approved. Recharge Zone features can be found in the geologic site assessment found in the next portion of the report.

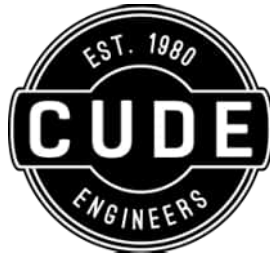

## ESTANCIA RANCH, UNIT 3

### *GEOLOGIC ASSESSMENT SECTION (TCEQ-0585)*



GEOLOGIC ASSESSMENT FOR ESTANCIA  
RANCH SUBDIVISION UNIT 3 SEWAGE  
COLLECTION SYSTEM, SAN ANTONIO, TEXAS

OCTOBER 2023

PREPARED FOR

**Meritage Homes of Texas LLC.**

PREPARED BY

**SWCA Environmental Consultants**

Texas Board of Professional Geoscientists, Firm Registration No. 50159

# GEOLOGIC ASSESSMENT FOR ESTANCIA RANCH SUBDIVISION UNIT 3 SEWAGE COLLECTION SYSTEM, SAN ANTONIO, TEXAS

Prepared for

**Meritage Homes of Texas, LLC.**  
2722 W. Bitters Road Ste 200  
San Antonio, Texas 78249



Prepared by

**SWCA Environmental Consultants**  
Texas Board of Professional Geoscientists, Firm Registration No. 50159  
4949 N. Loop 1604 W., Suite 235  
San Antonio, Texas 78249  
(210) 877-2847  
[www.swca.com](http://www.swca.com)

SWCA Project No. 84734

October 2023

## CONTENTS

<b>1</b>	<b>Introduction</b> .....	<b>1</b>
<b>2</b>	<b>Methodology</b> .....	<b>1</b>
<b>3</b>	<b>Results</b> .....	<b>3</b>
3.1	Project Area Overview .....	3
3.2	Soils .....	3
3.3	Geology .....	5
3.4	Hydrogeologic Assessment .....	5
3.5	Feature Descriptions .....	5
<b>4</b>	<b>Literature Cited</b> .....	<b>6</b>

## Appendices

Appendix A	Texas Commission on Environmental Quality (TCEQ) Forms
Appendix B	Site Photographs

## Figures

Figure 1.	Project location map. ....	2
Figure 2.	Soils map. ....	4

## Tables

Table 1.	Soil Map Units Within the Project Area .....	3
----------	--	---



# 1 INTRODUCTION

This narrative Geologic Assessment accompanies Texas Commission on Environmental Quality (TCEQ) Geologic Assessment Form TCEQ-0585 completed for the proposed Estancia Ranch Subdivision Unit 3 Sewage Collection System (SCS) (project). The project is approximately 2,700 linear feet of proposed sanitary sewer lines that will be tied into an existing sanitary sewage collection system (project site). The project area occurs within northern Bexar County, Texas (Figure 1).

# 2 METHODOLOGY

SWCA Environmental Consultants (SWCA) scientists studied records pertaining to reported caves in the project area and gathered information related to documented caves in the project vicinity prior to conducting field work. Relevant information sources include:

- Internal SWCA data;
- ESRI® ArcGIS® Online Basemap Map Services;
- U.S. Geological Survey (2019) 7.5-minute topographic digital raster graphics;
- Geologic maps (Barnes 1974; Collins 1994);
- The Caves of Bexar County (Veni 1985); and
- Mapped fault lines (Collins 1994).

An SWCA geoscientist conducted a field survey on October 3, 2023. The pedestrian survey was completed by walking parallel transects spaced approximately 30 to 50 feet apart, as directed by the TCEQ in the Instructions to Geologists for Geologic Assessments on the Edwards Aquifer Recharge/Transition Zones (Rev. 10-01-04). Closer spacing was used where vegetation inhibited observation. SWCA scientists carefully examined all potential karst features, including depressions, holes, and animal burrows, for subsurface extent evidence. SWCA used several techniques for this effort, including probing with a digging implement to determine the thickness and consistency of fill material and feeling for air flow which may indicate the presence of a sub-surface void space. Other techniques included recording notable features and site characteristics, such as vegetation types or semi-circular burrow mounds produced by small mammal activity.

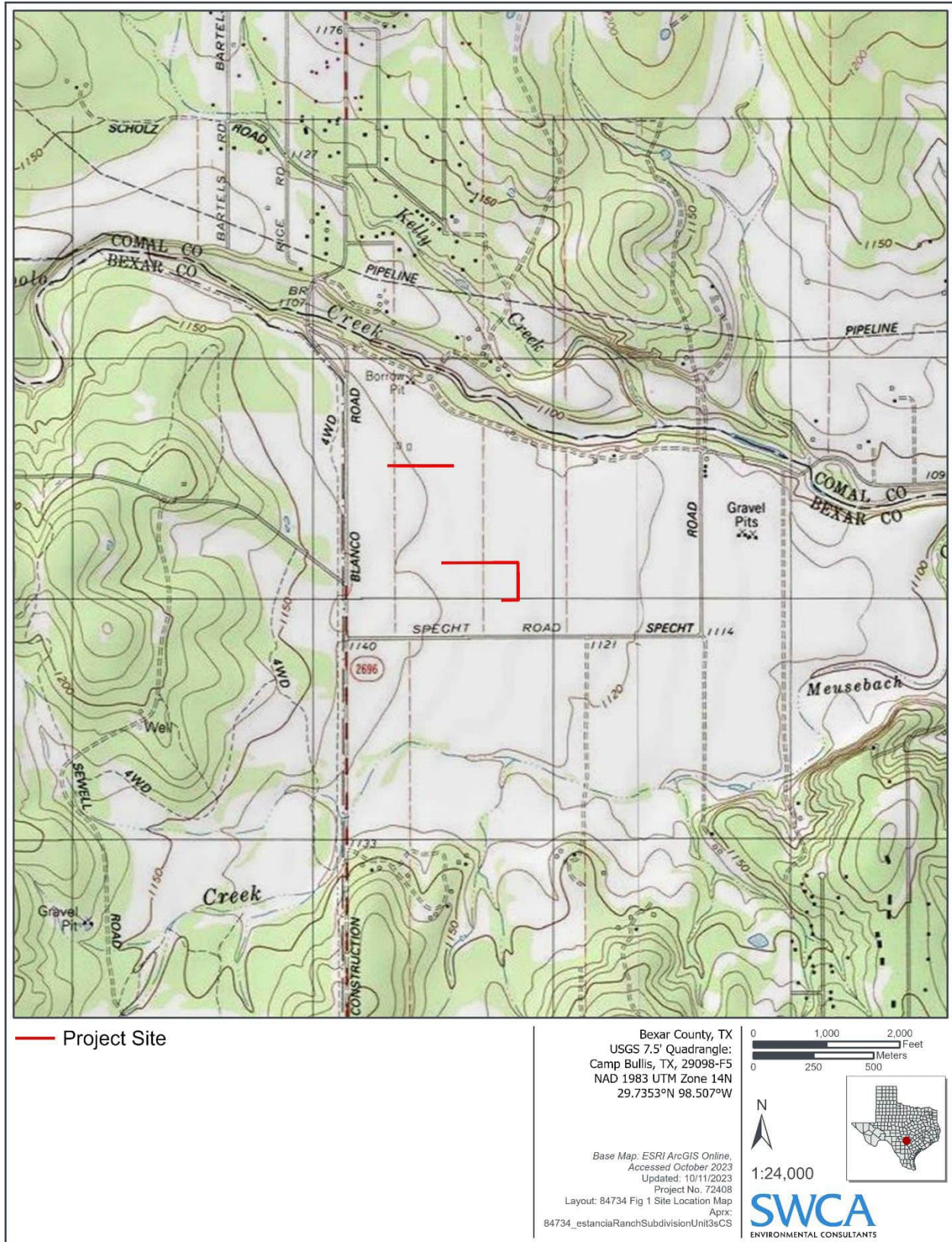

Figure 1. Project location map.

### 3 RESULTS

#### 3.1 PROJECT AREA OVERVIEW

The project site occurs within the Edwards Aquifer Recharge Zone (EARZ), which is in the northern segment of the Edwards Aquifer (TCEQ 2023). Topography within and surrounding the project area slopes from the southwest to the northeast. Ground elevation within the project area ranges from ±1120 to ±1140 feet above mean sea level (USGS 2019).

The project site is approximately 2,700 linear feet of proposed sanitary sewer lines that will be tied into an existing sanitary sewage collection system. The project site consists of rural land that had been cleared for a proposed housing development. The project site is located within the Cibolo Creek watershed of the Brazos River Basin. Surface water in the project site generally flows north into Cibolo Creek, located approximately 0.2 miles north, flowing east.

#### 3.2 SOILS

The Natural Resources Conservation Service (2023) identified two soil units within the project area (Figure 2). Table 1 provides additional details for these soil units. Figure 2 displays the limits of the soil units.

**Table 1. Soil Map Units Within the Project Area**

Soil Map Unit Name	Soil Description	Soil Group
Anhalt clay, 0 to 2 percent slopes (Ca)	Clayey residuum weathered from limestone	D
Lewisville silty clay, 1 to 3 percent slopes (LVA)	Calcareous clayey residuum weathered from mudstone	B

Group B. Soils have a moderate infiltration rate when thoroughly wet. These consist chiefly of moderately deep or deep, moderately well drained or well drained soils that have moderately fine texture to moderately coarse texture. These soils have a moderate rate of water transmission.

Group D. Soils have a very slow infiltration rate (high runoff potential) when thoroughly wet. These consist chiefly of clays that have a high shrink-swell potential, soils that have a high water table, soils that have a claypan or clay layer at or near the surface, and soils that are shallow over nearly impervious material. These soils have a very slow rate of water transmission.

Source: NRCS (2023).



Figure 2. Soils map.

### **3.3 GEOLOGY**

The project site occurs along the Balcones Fault Zone (BFZ) within the Edwards Aquifer Recharge Zone (TCEQ 2023). Structural down-warping occurred with the Gulf of Mexico's ancestral formation during the middle Tertiary. The earth's crust was stretched in response, and the BFZ formed along a zone of weakness, which currently marks the boundary between the Edwards Plateau and the Gulf Coastal Plain in central Texas. The BFZ is characterized by a series of northeast-trending, predominantly normal, nearly vertical, en echelon faults. No faults are mapped crossing the project area.

Rock outcropping on the project area is Cretaceous in age and consists of Quaternary fluvial deposits overlying the lower member of the Glen Rose Formation (Attachment D). The geology of the project site has been mapped recently at a useful scale by Collins (1994) and SWCA finds this interpretation of the geology to be generally accurate. A Stratigraphic Column is included as Attachment B within Appendix A.

Recharge into the Edwards Aquifer primarily occurs in areas where the Edwards Group and Georgetown Formation are exposed at the surface. Most recharge is from direct infiltration via precipitation and streamflow loss. Recharge occurs predominantly along secondary porosity features such as faults, fractures, and karst features (caves, solution cavities, sinkholes, etc.). Karst features are commonly formed along joints, fractures, and within bedding plane surfaces in the Edwards Group and Georgetown Formation. Although neither the Georgetown nor Edwards Group are exposed at or near the project site, portions of Cibolo Creek are included within the Edwards Aquifer Recharge Zone, because some evidence suggests water recharging the lower member of the Glen Rose Formation along Cibolo Creek indirectly recharges the Edwards Aquifer downstream where faults juxtapose the Glen Rose Formation and Edwards Group.

### **3.4 HYDROGEOLOGIC ASSESSMENT**

The overall potential for fluid migration to the Edwards Aquifer within the project site appears relatively low compared to background infiltration rates due to lack of geologic features. The depth to water in the vicinity of the project area has been measured at 62 feet below ground surface in nearby Trinity Aquifer well (State ID No. 6820307) (TWDB 2023). No wells were observed within the project site boundary.

The gentle contours shown on Appendix A, Attachment D suggest runoff from rainfall reaching the undisturbed portions of the project area will flow downslope in the form of sheet flow until collecting in Cibolo Creek, located approximately 0.2 miles north.

### **3.5 FEATURE DESCRIPTIONS**

**S-1** is a manmade feature in bedrock consisting of an existing sewage collection system. The trench for the sanitary sewer line was excavated into alluvium but might have penetrated underlying bedrock. The trench was then likely backfilled with a mixture of fine and coarse material that may be more permeable than surrounding undisturbed areas. The existing sewage collection system primarily lies beneath pavement, except for where the connection will be made, which will also be covered by pavement after construction is complete. Therefore, the probability of rapid infiltration is low.

**S-2** is a manmade feature in bedrock consisting of an existing sewage collection system. The trench for the sanitary sewer line was excavated into alluvium but might have penetrated underlying bedrock. The trench was then likely backfilled with a mixture of fine and coarse material that may be more permeable than surrounding undisturbed areas. The existing sewage collection system primarily lies beneath pavement, except for where the connection will be made, which will also be covered by pavement after construction is complete. Therefore, the probability of rapid infiltration is low.

## **4 LITERATURE CITED**

- Blome, C.D., Faith, J.R., Pedraza, D.E, Ozuna, G.B, Cole, J.C., Clark, A.K., Small, T.A., and Morris, R.R. 2005. Geologic Map of the Edwards Aquifer Recharge Zone, South-Central Texas. U.S. Geological Survey SIM-2873. Scale 1:200,000.
- Collins, E. 1994. Geologic Map of the Camp Bullis Quadrangle, Texas. University of Texas at Austin, Bureau of Economic Geology, Open-File Map OFM0016. Scale 1:24,000.
- Natural Resource Conservation Service (NRCS). 20232. Soil Survey Staff, Natural Resources Conservation Service, United States Department of Agriculture. Web Soil Survey. Available at: <http://websoilsurvey.nrcs.usda.gov/>. Accessed October 2023.
- Texas Commission on Environmental Quality. 2023. Edwards Aquifer Viewer v3.8. Available at: <http://tceq.maps.arcgis.com/apps/webappviewer/index.html?id=2e5afa3ba8144c30a49d3dc1ab49edcd>. Accessed October 2023.
- Texas Water Development Board (TWDB). 2023. Water Data Interactive, interactive GIS database. Available at: <http://www2.twdb.texas.gov/apps/waterdatainteractive/groundwaterdataviewer>. Accessed October 2023.
- Veni, G. 1988. *The Caves of Bexar County, Second Edition*. The Texas Memorial Museum, University of Texas, Austin, Texas.

## **APPENDIX A**

### **Texas Commission on Environmental Quality (TCEQ) Forms**

# Geologic Assessment

## Texas Commission on Environmental Quality

For Regulated Activities on The Edwards Aquifer Recharge/transition Zones and Relating to 30 TAC §213.5(b)(3), Effective June 1, 1999

**To ensure that the application is administratively complete, confirm that all fields in the form are complete, verify that all requested information is provided, consistently reference the same site and contact person in all forms in the application, and ensure forms are signed by the appropriate party.**

**Note: Including all the information requested in the form and attachments contributes to more streamlined technical reviews.**

## Signature

To the best of my knowledge, the responses to this form accurately reflect all information requested concerning the proposed regulated activities and methods to protect the Edwards Aquifer. My signature certifies that I am qualified as a geologist as defined by 30 TAC Chapter 213.

Print Name of Geologist: Philip Pearce P.G.

Telephone: 210.877.2847

Date: 10-23-23

Fax: 210.877.2848

Representing: SWCA Environmental Consultants (TBPG Firm Registration #50159) (Name of Company and TBPG or TBPE registration number)

Signature of Geologist:



**Regulated Entity Name:** Estancia Ranch Subdivision Unit 3 Sewage Collection System

## Project Information

1. Date(s) Geologic Assessment was performed: October 3, 2023

2. Type of Project:

WPAP

SCS

AST

UST

3. Location of Project:

Recharge Zone

Transition Zone

Contributing Zone within the Transition Zone





4.  **Attachment A - Geologic Assessment Table.** Completed Geologic Assessment Table (Form TCEQ-0585-Table) is attached.
5.  Soil cover on the project site is summarized in the table below and uses the SCS Hydrologic Soil Groups\* (Urban Hydrology for Small Watersheds, Technical Release No. 55, Appendix A, Soil Conservation Service, 1986). If there is more than one soil type on the project site, show each soil type on the site Geologic Map or a separate soils map.

**Table 1 - Soil Units, Infiltration Characteristics and Thickness**

Soil Name	Group*	Thickness(feet)
Anhalt clay, 0 to 2 percent slopes (Ca)	D	6-7
Lewisville silty clay, 1 to 3 percent slopes (LvA)	B	0-2

Soil Name	Group*	Thickness(feet)

*\* Soil Group Definitions (Abbreviated)*

- A. Soils having a high infiltration rate when thoroughly wetted.
- B. Soils having a moderate infiltration rate when thoroughly wetted.
- C. Soils having a slow infiltration rate when thoroughly wetted.
- D. Soils having a very slow infiltration rate when thoroughly wetted.

6.  **Attachment B – Stratigraphic Column.** A stratigraphic column showing formations, members, and thicknesses is attached. The outcropping unit, if present, should be at the top of the stratigraphic column. Otherwise, the uppermost unit should be at the top of the stratigraphic column.
7.  **Attachment C – Site Geology.** A narrative description of the site specific geology including any features identified in the Geologic Assessment Table, a discussion of the potential for fluid movement to the Edwards Aquifer, stratigraphy, structure(s), and karst characteristics is attached.
8.  **Attachment D – Site Geologic Map(s).** The Site Geologic Map must be the same scale as the applicant's Site Plan. The minimum scale is 1": 400'  
 Applicant's Site Plan Scale: 1" = 200'  
 Site Geologic Map Scale: 1" = 200'  
 Site Soils Map Scale (if more than 1 soil type): 1" = 416'
9. Method of collecting positional data:
  - Global Positioning System (GPS) technology.
  - Other method(s). Please describe method of data collection: \_\_\_\_\_

10.  The project site and boundaries are clearly shown and labeled on the Site Geologic Map.
11.  Surface geologic units are shown and labeled on the Site Geologic Map.
12.  Geologic or manmade features were discovered on the project site during the field investigation. They are shown and labeled on the Site Geologic Map and are described in the attached Geologic Assessment Table.
- Geologic or manmade features were not discovered on the project site during the field investigation.
13.  The Recharge Zone boundary is shown and labeled, if appropriate.
14. All known wells (test holes, water, oil, unplugged, capped and/or abandoned, etc.): If applicable, the information must agree with Item No. 20 of the WPAP Application Section.
- There are \_\_\_\_\_ (#) wells present on the project site and the locations are shown and labeled. (Check all of the following that apply.)
- The wells are not in use and have been properly abandoned.
- The wells are not in use and will be properly abandoned.
- The wells are in use and comply with 16 TAC Chapter 76.
- There are no wells or test holes of any kind known to exist on the project site.

### ***Administrative Information***

15.  Submit one (1) original and one (1) copy of the application, plus additional copies as needed for each affected incorporated city, groundwater conservation district, and county in which the project will be located. The TCEQ will distribute the additional copies to these jurisdictions. The copies must be submitted to the appropriate regional office.

**ATTACHMENT A**  
**Geologic Assessment Table**

GEOLOGIC ASSESSMENT TABLE										PROJECT NAME: Estancia Ranch Subdivision Unit 3 SCS									
LOCATION			FEATURE CHARACTERISTICS										EVALUATION		PHYSICAL SETTING				
1A	1B*	1C*	2A	2B	3	4			5	5A	6	7	8A	8B	9	10	11		12
FEATURE ID	LATITUDE	LONGITUDE	FEATURE TYPE	POINTS	FORMATION	DIMENSIONS (FEET)			TREND (DEGREES)	DENSITY (NO/FT)	APERTURE (FEET)	INFILL	RELATIVE INFILTRATION RATE	TOTAL	SENSITIVITY		CATCHMENT AREA (ACRES)	TOPOGRAPHY	
						X	Y	Z		10						<40	≥40	<1.6	≥1.6
S-1	29.732070°	-98.506132°	MB	30	Kgrl		50		-	0		X	5	35	X		X		Hillside
S-2	29.737113°	-98.511000°	MB	30	Kgrl		50		-	0		X	5	35	X		X		Hillside

\* DATUM: Geographic Latitude Longitude Decimal Degrees NAD83

2A TYPE	TYPE	2B POINTS
C	Cave	30
SC	Solution cavity	20
SF	Solution-enlarged fracture(s)	20
F	Fault	20
O	Other natural bedrock features	5
MB	Manmade feature in bedrock	30
SW	Swallow hole	30
SH	Sinkhole	20
CD	Non-karst closed depression	5
Z	Zone, clustered or aligned features	30

8A INFILLING	
N	None, exposed bedrock
C	Coarse - cobbles, breakdown, sand, gravel
O	Loose or soft mud or soil, organics, leaves, sticks, dark colors
F	Fines, compacted clay-rich sediment, soil profile, gray or red colors
V	Vegetation. Give details in narrative description
FS	Flowstone, cements, cave deposits
X	Other materials

12 TOPOGRAPHY
Cliff, Hilltop, Hillside, Drainage, Floodplain, Streambed

I have read, I understood, and I have followed the Texas Commission on Environmental Quality's Instructions to Geologists. The information presented here complies with that document and is a true representation of the conditions observed in the field. My signature certifies that I am qualified as a geologist as defined by 30 TAC Chapter 213.



Date 10-23-2023

Sheet 1 of 1



**ATTACHMENT B**  
**Stratigraphic Column**

**Stratigraphic Column**

Note: The shaded areas represent the lithology that outcrops on the property.<sup>1</sup>

Upper Cretaceous	Upper Confining Units		Navarro and Taylor Groups, undivided; 600 feet thick		
			Austin Group; 130-150 feet thick		
			Eagle Ford Group; 30-50 feet thick		
			Buda Limestone; 40-50 feet thick		
			Del Rio Clay; 40-50 feet thick		
Lower Cretaceous	I II III IV V VI VII VIII	Edwards Aquifer	Edwards Group	Georgetown Formation	10-40 feet thick
				Person Formation; 170-200 feet thick	Cyclic and Marine member, undivided
					Leached and Collapsed member, undivided
					Regional Dense member
				Kainer Formation; 260-310 feet thick	Grainstone member
					Kirschberg Evaporite member
					Dolomitic member
					Basal Nodular member
	Lower Confining Units		Upper member of Glen Rose Formation; 350-500 feet thick		
			Lower member of Glen Rose Formation; 350-500 feet thick		

<sup>1</sup> Blome, C.D., Faith, J.R., Pdraza, D.E, Ozuna, G.B, Cole, J.C., Clark, A.K., Small, T.A., and Morris, R.R. 2005. Geologic map of the Edwards aquifer recharge zone, south-central-Texas. U.S. Geological Survey SIM-2873. Scale 1:200,000.

**ATTACHMENT C**  
**Narrative Description of Site Geology**

## **NARRATIVE DESCRIPTION OF GEOLOGY**

### **Structure and Stratigraphy**

The project site occurs along the Balcones Fault Zone (BFZ) within the Edwards Aquifer Recharge Zone (TCEQ 2023). Structural down-warping occurred with the Gulf of Mexico's ancestral formation during the middle Tertiary. The earth's crust was stretched in response, and the BFZ formed along a zone of weakness, which currently marks the boundary between the Edwards Plateau and the Gulf Coastal Plain in central Texas. The BFZ is characterized by a series of northeast-trending, predominantly normal, nearly vertical, en echelon faults. No faults are mapped crossing the project area. The predominant trend for the project site is approximately N55°E, based on the trend of a fault located to the northeast.

Rock outcropping on the project area is Cretaceous in age and consists of Quaternary fluvial deposits overlying the lower member of the Glen Rose Formation (Kg1) (Attachment D), which is cave bearing. Caves within the Kg1 are a combination of vadose formed shafts and phreatic formed rooms and conduits. The geology of the project site has been mapped recently at a useful scale by Collins (1994) and SWCA finds this interpretation of the geology to be generally accurate. A Stratigraphic Column is included as Attachment B within Appendix A.

### **Hydrogeologic Assessment**

Recharge into the Edwards Aquifer primarily occurs in areas where the Edwards Group and Georgetown Formation are exposed at the surface. Most recharge is from direct infiltration via precipitation and streamflow loss. Recharge occurs predominantly along secondary porosity features such as faults, fractures, and karst features (caves, solution cavities, sinkholes, etc.). Karst features are commonly formed along joints, fractures, and within bedding plane surfaces in the Edwards Group and Georgetown Formation. Although neither the Georgetown nor Edwards Group are exposed at or near the project site, portions of Cibolo Creek are included within the Edwards Aquifer Recharge Zone, because some evidence suggests water recharging the lower member of the Glen Rose Formation along Cibolo Creek indirectly recharges the Edwards Aquifer downstream where faults juxtapose the Glen Rose Formation and Edwards Group.

The overall potential for fluid migration to the Edwards Aquifer within the project site appears relatively low compared to background infiltration rates due lack of geologic features. The depth to water in the vicinity of the project area has been measured at 62 feet below ground surface in nearby Trinity Aquifer well (State ID No. 6820307) (TWDB 2023). No wells were observed within the project site boundary.

The gentle contours shown on Appendix A, Attachment D suggest runoff from rainfall reaching the undisturbed portions of the project area will flow downslope in the form of sheet flow until collecting in Cibolo Creek, located approximately 0.2 miles north.

### **Feature Descriptions**

Feature S-1 is a manmade feature in bedrock consisting of an existing sewage collection system. The trench for the sanitary sewer line was excavated into alluvium but might have penetrated underlying bedrock. The trench was then likely backfilled with a mixture of fine and coarse material that may be more permeable than surrounding undisturbed areas. The existing sewage collection system lies primarily beneath pavement, except for where the connection will be made, which will also be covered by pavement after construction is complete. Therefore, the probability of rapid infiltration is low.



Feature S-2 is a manmade feature in bedrock consisting of an existing sewage collection system. The trench for the sanitary sewer line was excavated into alluvium but might have penetrated underlying bedrock. The trench was then likely backfilled with a mixture of fine and coarse material that may be more permeable than surrounding undisturbed areas. The existing sewage collection system lies primarily beneath pavement, except for where the connection will be made, which will also be covered by pavement after construction is complete. Therefore, the probability of rapid infiltration is low.

**ATTACHMENT D**  
**Site Geologic Map**

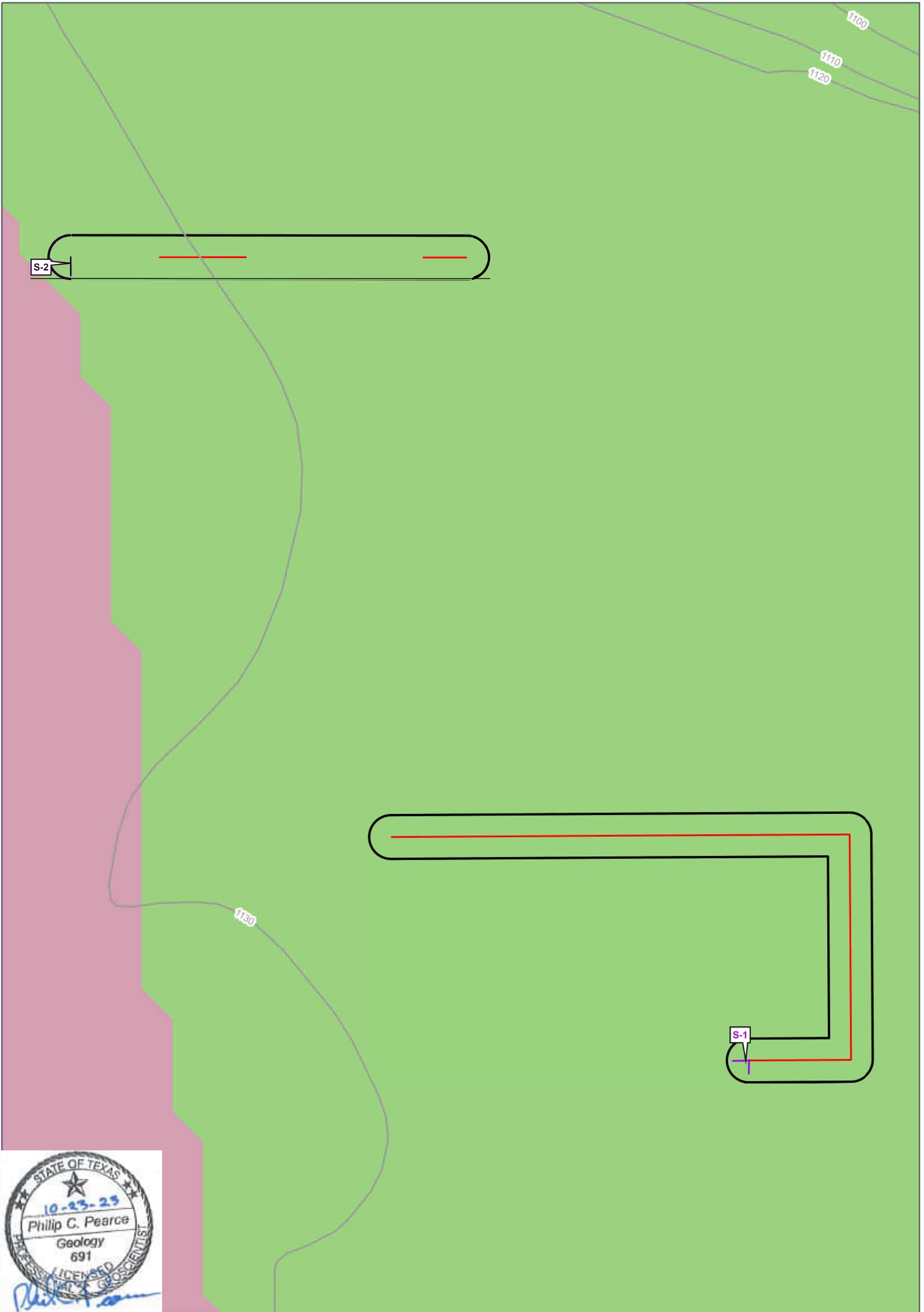

ESTANCIA RANCH SUBDIVISION  
UNIT 3 SCS GEOLOGIC  
ASSESSMENT  
**Site Geologic Map**

- Estancia Ranch Unit 3 SCS
- Existing Sewer Line
- USGS Contour Line
- 100-ft Wide Envelope
- Kgrl - Lower Glen Rose Formation
- Qt - Quaternary Fluvial Terrace Deposits

Bexar County, TX  
USGS 7.5' Quadrangle:  
Camp Bullis, TX, 29098-F5  
NAD 1983 UTM Zone 14N  
29.7346°N 98.5082°W

0 100 200  
0 25 50  
Meters  
Feet

N

1:2,400

Base Map: ESRI ArcGIS Online, accessed October 2023  
Updated: 10/13/2023  
Project No. 84734  
Layout: 84734 Geologic Map 11x17  
Aprx: 84734\_estanciaRanchSubdivisionUnit3sCS

**SWCA**  
ENVIRONMENTAL CONSULTANTS

## **APPENDIX B**

### **Photographic Log**

Estancia Ranch Unit 3 SCS Geologic Assessment



Photograph 1. Proposed SCS right-of-way.



Photograph 2. Proposed SCS right-of-way.

Estancia Ranch Unit 3 SCS Geologic Assessment



Photograph 3. Existing sewer line S-2.



Photograph 4. Existing sewer line S-1.

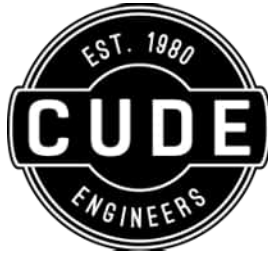

## ESTANCIA RANCH, UNIT 3

# *ORGANIZED SEWAGE COLLECTION SYSTEM PLAN (TCEQ-0582)*

# Organized Sewage Collection System Application

## Texas Commission on Environmental Quality

For Regulated Activities on the Edwards Aquifer Recharge Zone and Relating to 30 TAC §213.5(c), Effective June 1, 1999

***To ensure that the application is administratively complete, confirm that all fields in the form are complete, verify that all requested information is provided, consistently reference the same site and contact person in all forms in the application, and ensure forms are signed by the appropriate party.***

***Note: Including all the information requested in the form and attachments contributes to more streamlined technical reviews.***

**Regulated Entity Name:** Estancia Ranch, Unit 3

1.  **Attachment A – SCS Engineering Design Report.** This Engineering Design Report is provided to fulfill the requirements of 30 TAC Chapter 217, including 217.10 of Subchapter A, §§217.51 – 217.70 of Subchapter C, and Subchapter D as applicable, and is required to be submitted with this SCS Application Form.

## Customer Information

2. The entity and contact person responsible for providing the required engineering certification of testing for this sewage collection system upon completion (including private service connections) and every five years thereafter to the appropriate TCEQ region office pursuant to 30 TAC §213.5(c) is:

Contact Person: Brian Otto

Entity: Meritage Homes of Texas, L.L.C.

Mailing Address: 2722 W. Bitters Rd., Suite 200

City, State: San Antonio, TX

Zip: 78248

Telephone: 210-260-6069

Fax: \_\_\_\_\_

Email Address: brian.otto@meritagehomes.com

***The appropriate regional office must be informed of any changes in this information within 30 days of the change.***

3. The engineer responsible for the design of this sewage collection system is:

Contact Person: Andrew R. Lowry, P.E.

Texas Licensed Professional Engineer's Number: 123410

Entity: Cude Engineers

Mailing Address: 4122 Pond Hill Rd., Suite 101

City, State: San Antonio, TX

Zip: 78231

Telephone: 210-681-2951

Fax: 210-523-7112

Email Address: alowry@cudeengineers.com



## Project Information

4. Anticipated type of development to be served (estimated future population to be served, plus adequate allowance for institutional and commercial flows):

- Residential: Number of single-family lots: 152  
 Multi-family: Number of residential units: \_\_\_\_\_  
 Commercial  
 Industrial  
 Off-site system (not associated with any development)  
 Other: \_\_\_\_\_

5. The character and volume of wastewater is shown below:

<u>100</u> % Domestic	<u>100,800</u> gallons/day
_____% Industrial	____ gallons/day
_____% Commingled	____ gallons/day
Total gallons/day: <u>29,040</u>	

6. Existing and anticipated infiltration/inflow is 29,040 gallons/day. This will be addressed by: Sufficient capacity in the main has been accounted for based on the additional anticipated inflow / infiltration for the drainage shed to the proposed and future service areas. Periodic monitoring of manhole exfiltration will be determined by a hydrostatic exfiltration test or manhole vacuum test. Sanitary sewer lines will be periodically monitored using a low pressure air test in accordance with ASTM C-828 or ASTM F-1417. If the quantity of infiltration (if sanitary sewer pipes are installed below groundwater) or exfiltration exceeds the maximum specified amount per TCEQ Design Criteria for Wastewater Systems, Chapter 217.57(a)(2)(C), remedial action shall be undertaken in order to reduce the infiltration or exfiltration to an amount within specified limits. The owner shall retest sanitary sewer facilities to confirm the remedial action was successful.

7. A Water Pollution Abatement Plan (WPAP) is required for construction of any associated commercial, industrial or residential project located on the Recharge Zone.

- The WPAP application for this development was approved by letter dated July 16, 2020. A copy of the approval letter is attached.  
 The WPAP application for this development was submitted to the TCEQ on \_\_\_\_\_, but has not been approved.  
 A WPAP application is required for an associated project, but it has not been submitted.  
 There is no associated project requiring a WPAP application.

8. Pipe description:

**Table 1 - Pipe Description**

<i>Pipe Diameter(Inches)</i>	<i>Linear Feet (1)</i>	<i>Pipe Material (2)</i>	<i>Specifications (3)</i>
8	2,706.71	PVC SDR-26	ASTM D-3034

<i>Pipe Diameter(Inches)</i>	<i>Linear Feet (1)</i>	<i>Pipe Material (2)</i>	<i>Specifications (3)</i>

**Total Linear Feet: 2,706.71**

- (1) Linear feet - Include stub-outs and double service connections. Do not include private service laterals.
- (2) Pipe Material - If PVC, state SDR value.
- (3) Specifications - ASTM / ANSI / AWWA specification and class numbers should be included.

9. The sewage collection system will convey the wastewater to the Dos Rios (name) Treatment Plant. The treatment facility is:

- Existing
- Proposed

10. All components of this sewage collection system will comply with:

- The City of San Antonio standard specifications.
- Other. Specifications are attached.

11.  No force main(s) and/or lift station(s) are associated with this sewage collection system.
- A force main(s) and/or lift station(s) is associated with this sewage collection system and the **Lift Station/Force Main System Application** form (TCEQ-0624) is included with this application.

### ***Alignment***

12.  There are no deviations from uniform grade in this sewage collection system without manholes and with open cut construction.
13.  There are no deviations from straight alignment in this sewage collection system without manholes.
- Attachment B - Justification and Calculations for Deviation in Straight Alignment without Manholes.** A justification for deviations from straight alignment in this sewage collection system without manholes with documentation from pipe manufacturer allowing pipe curvature is attached.
  - For curved sewer lines, all curved sewer line notes (TCEQ-0596) are included on the construction plans for the wastewater collection system.

### ***Manholes and Cleanouts***

14.  Manholes or clean-outs exist at the end of each sewer line(s). These locations are listed below: (Please attach additional sheet if necessary)

**Table 2 - Manholes and Cleanouts**

<i>Line</i>	<i>Shown on Sheet</i>	<i>Station</i>	<i>Manhole or Clean-out?</i>
B	C29 Of C29	24+79.61	Manhole
H	C30 Of C30	3+33.98	Manhole
H	C30 Of C30	5+98.84	Manhole
H	C30 Of C30	8+48.84	Manhole
H	C31 Of C31	13+48.84	Manhole
H	C31 Of C31	18+98.12	Manhole
	Of		
	Of		
	Of		
	Of		

15.  Manholes are installed at all Points of Curvature and Points of Termination of a sewer line.
16.  The maximum spacing between manholes on this project for each pipe diameter is no greater than:

<b>Pipe Diameter (inches)</b>	<b>Max. Manhole Spacing (feet)</b>
6 - 15	500
16 - 30	800
36 - 48	1000
≥54	2000

- Attachment C – Justification for Variance from Maximum Manhole Spacing.** The maximum spacing between manholes on this project (for each pipe diameter used) is greater than listed in the table above. A justification for any variance from the maximum spacing is attached, and must include a letter from the entity which will operate and maintain the system stating that it has the capability to maintain lines with manhole spacing greater than the allowed spacing.
17.  All manholes will be monolithic, cast-in-place concrete.
- The use of pre-cast manholes is requested for this project. The manufacturer's specifications and construction drawings, showing the method of sealing the joints, are attached.

**Site Plan Requirements**

*Items 18 - 25 must be included on the Site Plan.*

18.  The Site Plan must have a minimum scale of 1" = 400'.  
 Site Plan Scale: 1" = 80'.

19.  The Site Plan must include the sewage collection system general layout, including manholes with station numbers, and sewer pipe stub outs (if any). Site plan must be overlain by topographic contour lines, using a contour interval of not greater than ten feet and showing the area within both the five-year floodplain and the 100-year floodplain of any drainage way.

20. Lateral stub-outs:

- The location of all lateral stub-outs are shown and labeled.
- No lateral stub-outs will be installed during the construction of this sewer collection system.

21. Location of existing and proposed water lines:

- The entire water distribution system for this project is shown and labeled.
- If not shown on the Site Plan, a Utility Plan is provided showing the entire water and sewer systems.
- There will be no water lines associated with this project.

22. 100-year floodplain:

- After construction is complete, no part of this project will be in or cross a 100-year floodplain, either naturally occurring or manmade. (Do not include streets or concrete-lined channels constructed above of sewer lines.)
- After construction is complete, all sections located within the 100-year floodplain will have water-tight manholes. These locations are listed in the table below and are shown and labeled on the Site Plan. (Do not include streets or concrete-lined channels constructed above sewer lines.)

**Table 3 - 100-Year Floodplain**

<i>Line</i>	<i>Sheet</i>	<i>Station</i>
	of	to
	of	to
	of	to
	of	to

23. 5-year floodplain:

- After construction is complete, no part of this project will be in or cross a 5-year floodplain, either naturally occurring or man-made. (Do not include streets or concrete-lined channels constructed above sewer lines.)
- After construction is complete, all sections located within the 5-year floodplain will be encased in concrete or capped with concrete. These locations are listed in the table below and are shown and labeled on the Site Plan. (Do not include streets or concrete-lined channels constructed above sewer lines.)

**Table 4 - 5-Year Floodplain**

<i>Line</i>	<i>Sheet</i>	<i>Station</i>

<i>Line</i>	<i>Sheet</i>	<i>Station</i>
	of	to
	of	to
	of	to
	of	to

24.  Legal boundaries of the site are shown.
25.  The **final plans and technical specifications** are submitted for the TCEQ's review. Each sheet of the construction plans and specifications are dated, signed, and sealed by the Texas Licensed Professional Engineer responsible for the design on each sheet.

**Items 26 - 33 must be included on the Plan and Profile sheets.**

26.  All existing or proposed water line crossings and any parallel water lines within 9 feet of sewer lines are listed in the table below. These lines must have the type of pressure rated pipe to be installed shown on the plan and profile sheets. Any request for a variance from the required pressure rated piping at crossings must include a variance approval from 30 TAC Chapter 290.
- There will be no water line crossings.
- There will be no water lines within 9 feet of proposed sewer lines.

**Table 5 - Water Line Crossings**

<i>Line</i>	<i>Station or Closest Point</i>	<i>Crossing or Parallel</i>	<i>Horizontal Separation Distance</i>	<i>Vertical Separation Distance</i>

27. Vented Manholes:
- No part** of this sewer line is within the 100-year floodplain and vented manholes are not required by 30 TAC Chapter 217.
- A portion** of this sewer line is within the 100-year floodplain and vented manholes will be provided at less than 1500 foot intervals. These water-tight manholes are listed in the table below and labeled on the appropriate profile sheets.

- A portion** of this sewer line is within the 100-year floodplain and an alternative means of venting shall be provided at less than 1500 feet intervals. A description of the alternative means is described on the following page.
- A portion** of this sewer line is within the 100-year floodplain; however, there is no interval longer than 1500 feet located within. No vented manholes will be used.

**Table 6 - Vented Manholes**

<i>Line</i>	<i>Manhole</i>	<i>Station</i>	<i>Sheet</i>

28. Drop manholes:

- There are no drop manholes associated with this project.
- Sewer lines which enter new or existing manholes or "manhole structures" higher than 24 inches above the manhole invert are listed in the table below and labeled on the appropriate profile sheets. These lines meet the requirements of 30 TAC §217.55(I)(2)(H).

**Table 7 - Drop Manholes**

<i>Line</i>	<i>Manhole</i>	<i>Station</i>	<i>Sheet</i>

29. Sewer line stub-outs (For proposed extensions):

- The placement and markings of all sewer line stub-outs are shown and labeled.
- No sewer line stub-outs are to be installed during the construction of this sewage collection system.

30. Lateral stub-outs (For proposed private service connections):

- The placement and markings of all lateral stub-outs are shown and labeled.
- No lateral stub-outs are to be installed during the construction of this sewage collection system.

31. Minimum flow velocity (From Appendix A)

- Assuming pipes are flowing full; all slopes are designed to produce flows equal to or greater than 2.0 feet per second for this system/line.

32. Maximum flow velocity/slopes (From Appendix A)

- Assuming pipes are flowing full, all slopes are designed to produce maximum flows of less than or equal to 10 feet per second for this system/line.
- Attachment D – Calculations for Slopes for Flows Greater Than 10.0 Feet per Second.** Assuming pipes are flowing full, some slopes produce flows which are greater than 10 feet per second. These locations are listed in the table below. Calculations are attached.

**Table 8 - Flows Greater Than 10 Feet per Second**

<i>Line</i>	<i>Profile Sheet</i>	<i>Station to Station</i>	<i>FPS</i>	<i>% Slope</i>	<i>Erosion/Shock Protection</i>

33. Assuming pipes are flowing full, where flows are  $\geq 10$  feet per second, the provisions noted below have been made to protect against pipe displacement by erosion and/or shock under 30 TAC §217.53(l)(2)(B).

- Concrete encasement shown on appropriate Plan and Profile sheets for the locations listed in the table above.
- Steel-reinforced, anchored concrete baffles/retards placed every 50 feet shown on appropriate Plan and Profile sheets for the locations listed in the table above.
- N/A

**Administrative Information**

- 34.  The final plans and technical specifications are submitted for TCEQ review. Each sheet of the construction plans and specifications are dated, signed, and sealed by the Texas Licensed Professional Engineer responsible for the design on each sheet.
- 35.  Standard details are shown on the detail sheets, which are dated, signed, and sealed by the Texas Licensed Professional Engineer, as listed in the table below:

**Table 9 - Standard Details**

<i>Standard Details</i>	<i>Shown on Sheet</i>
Lateral stub-out marking <b>[Required]</b>	C32 of C32
Manhole, showing inverts comply with 30 TAC §217.55(l)(2) <b>[Required]</b>	C32 of C32
Alternate method of joining lateral to existing SCS line for potential future connections <b>[Required]</b>	C32 of C32
Typical trench cross-sections <b>[Required]</b>	C32 of C32
Bolted manholes <b>[Required]</b>	C32 of C32

<b>Standard Details</b>	<b>Shown on Sheet</b>
Sewer Service lateral standard details <b>[Required]</b>	C32 of C32
Clean-out at end of line <b>[Required, if used]</b>	N/A of N/A
Baffles or concrete encasement for shock/erosion protection <b>[Required, if flow velocity of any section of pipe &gt;10 fps]</b>	N/A of N/A
Detail showing Wastewater Line/Water Line Crossing <b>[Required, if crossings are proposed]</b>	N/A of N/A
Mandrel detail or specifications showing compliance with 30 TAC §217.57(b) and (c) <b>[Required, if Flexible Pipe is used]</b>	C32 of C32
Drop manholes <b>[Required, if a pipe entering a manhole is more than 24 inches above manhole invert]</b>	N/A of N/A

36.  All organized sewage collection system general construction notes (TCEQ-0596) are included on the construction plans for this sewage collection system.
37.  All proposed sewer lines will be sufficiently surveyed/staked to allow an assessment prior to TCEQ executive director approval. If the alignments of the proposed sewer lines are not walkable on that date, the application will be deemed incomplete and returned.
- Survey staking was completed on this date: As requested by TCEQ staff.
38.  Submit one (1) original and one (1) copy of the application, plus additional copies as needed for each affected incorporated city, groundwater conservation district, and county in which the project will be located. The TCEQ will distribute the additional copies to these jurisdictions. The copies must be submitted to the appropriate regional office.
39.  Any modification of this SCS application will require TCEQ approval, prior to construction, and may require submission of a revised application, with appropriate fees.

## **Signature**

To the best of my knowledge, the responses to this form accurately reflect all information requested concerning the proposed regulated activities and methods to protect the Edwards Aquifer. This **Organized Sewage Collection System Application** is hereby submitted for TCEQ review and executive director approval. The system was designed in accordance with the requirements of 30 TAC §213.5(c) and 30 TAC §217 and prepared by:

Print Name of Licensed Professional Engineer: Andrew R. Lowry, P.E.

Date: 9/21/23

Place engineer's seal here:



Signature of Licensed Professional Engineer:



10/30/23

## Appendix A-Flow Velocity Table

**Flow Velocity (Flowing Full)** All gravity sewer lines on the Edwards Aquifer Recharge Zone shall be designed and constructed with hydraulic slopes sufficient to give a velocity when flowing full of not less than 2.0 feet per second, and not greater than 10 feet per second. The grades shown in the following table are based on Manning's formula and an n factor of 0.013 and shall be the minimum and maximum acceptable slopes unless provisions are made otherwise.

**Table 10 - Slope Velocity**

<b>Pipe Diameter(Inches)</b>	<b>% Slope required for minimum flow velocity of 2.0 fps</b>	<b>% Slope which produces flow velocity of 10.0 fps</b>
6	0.50	12.35
8	0.33	8.40
10	0.25	6.23
12	0.20	4.88
15	0.15	3.62
18	0.11	2.83
21	0.09	2.30
24	0.08	1.93
27	0.06	1.65
30	0.055	1.43
33	0.05	1.26
36	0.045	1.12
39	0.04	1.01
>39	*	*

*\*For lines larger than 39 inches in diameter, the slope may be determined by Manning's formula (as shown below) to maintain a minimum velocity greater than 2.0 feet per second when flowing full and a maximum velocity less than 10 feet per second when flowing full.*

$$v = \frac{1.49}{n} \times R_h^{0.67} \times \sqrt{S}$$

**Figure 1 - Manning's Formula**

Where:

*v* = velocity (ft/sec)

*n* = Manning's roughness coefficient  
(0.013)

*R<sub>h</sub>* = hydraulic radius (ft)

*S* = slope (ft/ft)

Estancia Ranch, Unit 3  
Organized Sewage Collection System Plan



## ATTACHMENT A – ENGINEERING DESIGN REPORT

# TCEQ Engineering Design Report

For

## **Estancia Ranch, Unit 3** Organized Sewage Collection System

**SEPTEMBER 21, 2023**

Prepared By:

**M.W. Cude Engineers, LLC**  
4122 Pond Hill Road, Suite 101  
San Antonio, Texas 78231  
TBPE Registration Number: 455



10/30/23

## TABLE OF CONTENTS

Table of Contents	2
PVC Pipe Standards	3
Proposed Type of Pipe	4
Flow Capacity Analysis	4
Minimum and Maximum Grades for Pipes	5
Minimum and Maximum Velocities for the Proposed System	5
Average Values for Modulus of Soil Reaction, E'	6
Pipe Bedding Class	7
Pipe Bedding Angle	8
Live Load Determination	8
Prism Load Determination	9
Buckling Pressure (Allowable)	10
Buckling Pressure (Installed Condition)	11
Wall Crushing Calculation	12
Deflection Analysis: Leonhardt's Zeta Factor	14
Pipe Stiffness	15
Predicted Pipe Deflection	16
Pipe Strain	17
TCEQ Pipe Bedding and Trenching Requirements	19
Manhole Specifications	21

## ATTACHMENTS

**Attachment A: Utility Service Agreement**

**Attachment B: General Utilities Wastewater Notes**

## **PVC PIPE STANDARDS**

The American Society for Testing and Materials (ASTM) also known as ASTM International (Reference: [www.astm.org](http://www.astm.org)) governs the manufacturing specifications for Polyvinyl Chloride (PVC) pipes, including the dimension ratio and water pressure allowable for use of each pipe, through its D-3034 standard. ASTM D-3034 lists its pipe dimensions and pipe classes using the “SDR” mark up, such as SDR-13.5, SDR-21, SDR-26 and SDR-41. The SDR refers to the standard dimension ratio (SDR) of the outside pipe diameter and the wall thickness. This project specifies the use of SDR-26 PVC pipe, which are to meet the ASTM pressure rating of greater than 115 psi and fall in the size category listed below. ASTM D-3034 standards must be meticulously adhered to by all PVC pipe manufacturers and is recognized as the standard during PVC pressure pipe testing and quality checks. Other in-depth information can be found published in Thermoplastic Pressure Pipe Design and Selection UNI-TR-7, by the Uni-Bell PVC Pipe Association.

SDR 26 Pipe Size Matrix (Per ASTM D-3034)			
Size (in)	O.D. (in)	Calc I.D. (in)	Thickness (in)
4	4.215	3.891	0.162
6	6.275	5.793	0.241
8	8.400	7.754	0.323
10	10.500	9.692	0.404
12	12.500	11.538	0.481
15	15.300	14.124	0.588

**PROPOSED TYPE OF PIPE**

**Type I, Grade I, Polyvinyl Chloride (PVC) Specifications:**

**Size of Pipe: 8.00 in.**

**SDR 26 Properties**

Pipe Compliance:	ASTM D-3034
Joint Compliance:	ASTM D-3212
Cell Classification:	12454
Minimum Tensile Strength (psi):	7,000
Minimum Modulus of Elasticity (psi):	400,000
Calculated Inner Diameter (in) = (Outer Diameter - 2t)	7.754
Outer Diameter (inch):	8.400
Wall Thickness (inch):	0.323
Mean Pipe Diameter (in) = (Outer Diameter - Thickness)	8.077
Approximate Trenching Width (feet):	2.70

**Minimum Pipe Depth (Cover) used (feet): 5.30**

**Maximum Pipe Depth (Cover) used (feet): 19.30**

**FLOW/CAPACITY ANALYSIS**

Proposed Waste Water Usage: **100,800.00 GPD**

$Q_{max}$  (As determined in Attachment A) = 0.156 CFS

$$Q_{full} = \frac{1.486}{n} \times A \times R^{\frac{2}{3}} \times \sqrt{S}$$

A = Cross-Sectional Area, (ft<sup>2</sup>) = 0.328

S = Slope, decimal, minimum used = 0.004

R<sub>h</sub> = hydraulic radius = 0.162

For the Specified Pipe at the Minimum Design Slope, the full flow is

$$Q_{full} = 0.703 \text{ CFS}$$

$$0.156 < 0.703$$

**Design meets TCEQ Guidelines**

**MINIMUM AND MAXIMUM GRADES FOR PIPES (30 TAC §217.53(1)(2)(A))**

Minimum and Maximum Pipe Slopes		
Size of Pipe	Minimum Slope (%)	Maximum Slope (%)
6	0.5	12.35
8	0.33	8.4
10	0.25	6.23
12	0.2	4.88
15	0.15	3.62
18	0.11	2.83
21	0.09	2.3
24	0.08	1.93
27	0.06	1.65
30	0.055	1.43
33	0.05	1.26
36	0.045	1.12
39	0.04	1.01
>39	*	*

\* For pipes larger than 39 inches in diameter, the slope is determined by Manning's formula to maintain a velocity greater than **2.0 feet per second** and less than **10.0 feet per second** when flowing full.

**MINIMUM AND MAXIMUM VELOCITY FOR THE PROPOSED SYSTEM:**

So, using 8.00 inch PVC Pipe:

$$V = \frac{1.49}{n} \times R_h^{0.67} \times \sqrt{S}$$

V = velocity (ft/sec) = (solve)  
 n = Manning's coefficient = 0.013  
 Calc. Inner Diameter (in) = 7.754  
 A = Cross-Sectional Area, ft<sup>2</sup> = 0.328  
 Wp = Wetted Perimeter, ft = 2.030  
 R<sub>h</sub> = hydraulic radius, A/Wp = 0.162  
 S = slope (ft/ft) = 0.004

Minimum Slope Used (%): **0.40**                      Maximum Slope Used (%): **3.05**

V<sub>min</sub> = 2.15 ft/sec                      V<sub>max</sub> = 5.93 ft/sec

**2.15** > **2.00** ft/sec                      **5.93** < **10.00** ft/sec

**Design meets TCEQ Guidelines**                      **Design meets TCEQ Guidelines**



**AVERAGE VALUES OF MODULUS OF SOIL REACTION, E'**

Soil type-pipe bedding material (Unified Classification System)	Dumped	E' for Degree of Compaction of Bedding, in pounds per square inch		
		Slight < 85% Proctor, < 40% relative density	Moderate 85% -95% Proctor, 40% -70% relative density	High, > 95% Proctor, > 70% relative density
(1)	(2)	(3)	(4)	(5)
Fine-grained Soils (LL> 50 <sub>s</sub> ) Soils with medium to high plasticity CH, MH, CH-MH	No data available; consult a competent soils engineer; Otherwise use E=0			
Fine-grained Soils (LL<50) Soils with medium to no plasticity, CL, ML, ML-CL, with less than 25% coarse-grained particles	50	200	400	1000
Fine-grained Soils (LL<50) Soils with medium to no plasticity, CL, ML, ML-CL, with more than 25% coarse-grained particles	100	400	1000	2000
Coarse-grained Soils with Fines GM, GC, SM, SC <sup>c</sup> contains more than 12% fines				
Coarse-grained Soils with Little or no Fines GW, GP, SW, SP <sup>c</sup> contains less than 12% fines	200	1000	2000	3000
Crushed Rock	1000	3000	3000	3000
Accuracy in Terms of Percentage Deflection	± 2	± 2	± 1	± 0.5

Taken from: Howard, Amster K. "Soil Reaction for Buried Flexible Pipe"  
U.S. Bureau of Reclamation, Denver, CO and the American Society of Civil Engineers.

**Modulus of Soil Reaction for the in-situ soil is determined to be = 2000 psi**

**PIPE BEDDING CLASS**

Taken from the American Society for Testing and Material (ASTM) D 2321 and American Association of State Highway and Transportation Officials (AASHTO) M43, and as published on Table 7, in Deflection: The Pipe/Soil Mechanism UNI-TR-1-97, Uni-Bell PVC Pipe Association, Pg 24.

Pipe Embedment Material						E', psi (kPa) for Degree of Embedment Compaction				
ASTM D 2321*		ASTM D 2487		AASHTO M43 Notation	Min. Std. Proctor Density (%)	Lift Placement Depth	Dumped	Slightly < 85%	Moderate 85% - 95%	High > 95%
Class	Description	Notation	Description							
IA	Open-graded, clean manufactured aggregates	N/A	Angular crushed stone or rock, crushed gravel, crushed slag; large voids with little or no fines	5 56	Dumped	18" (0.45 m)	1000 (6,900)	3000 (20,700)	3000 (20,700)	3000 (20,700)
IB	Dense-graded, clean manufactured, processed aggregates	N/A	Angular crushed stone or other Class IA material and stone/sand mixtures; little or no fines							
II	Clean, coarse-grained soils	GW	Well-graded gravel, gravel/sand mixtures; little or no fines	57 6 67	85%	12" (0.30 m)	N/R	1000 (6,900)	2000 (13,800)	3000 (20,700)
		GP	Poorly graded gravel, gravel/sand mixtures; little or no fines							
		SW	Well-graded sands, gravelly sands; little or no fines							
		SP	Poorly graded sands, gravelly sands; little or no fines							
III	Coarse-grained soils with fines	GM	Silty gravels, gravel/sand/silt mixtures	Gravel and sand with <10% fines	90%	9" (0.20 m)	N/R	N/R	1000 (6,900)	2000 (13,800)
		GC	Clayey gravels, gravel/sand/clay mixtures							
		SM	Silty sands, sand/silt mixtures							
		SC	Clayey sands, sand/clay mixtures							

**NOTE:**

Per TCEQ guidelines, a contractor is allowed to use ASTM D 2321 Bedding Class 1A, 1B, II, or III at no less than 85% percent compaction. To grant the contractor its ability to make the proper judgment of which bedding class to use, the calculations provided in this Engineering Design Report reflect the use of **Bedding Class III, at >95%** compaction, with an E' value of 2000 psi. This provides the “worst case” scenario for the SCS line. All other Bedding Class options will provide an improved value for the zeta factor as well as pipe deflection.

**For Bedding Class III, >95% Compaction,**

**$E_b = 2000$  psi**

## PIPE BEDDING ANGLE

As Published on Figure 8 and Table 5, in Deflection: The Pipe/Soil Mechanism UNI-TR-1-97, Uni-Bell PVC Pipe Association, Pgs 18-19.

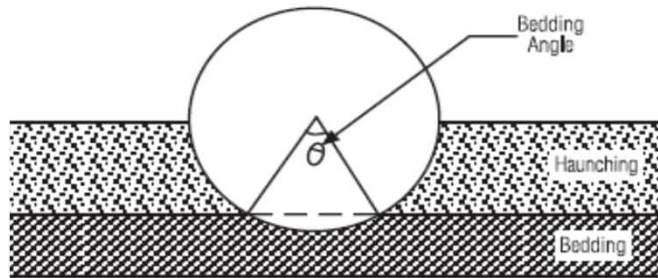

**Bedding Constant Values**

Bedding Angle, degrees	Bedding Constant
0	0.110
30	0.108
45	0.105
60	0.102
90	0.096
120	0.090
180	0.083

## LIVE LOAD DETERMINATION

Source: AASHTO H20 and E80 Loads and as Published on Table 4, in Deflection: The Pipe/Soil Mechanism UNI-TR-1-97, Uni-Bell PVC Pipe Association, Pg 14.

Height of Cover (ft)	Live Load Transferred to Pipe, lb/in <sup>2</sup>			Height of Cover (ft)	Live Load Transferred to Pipe, lb/in <sup>2</sup>		
	Highway H20 <sup>1</sup>	Railway E80 <sup>2</sup>	Airport <sup>3</sup>		Highway H20 <sup>1</sup>	Railway E80 <sup>2</sup>	Airport <sup>3</sup>
1	12.50			14	*	4.17	3.06
2	5.56	26.39	13.14	16	*	3.47	2.29
3	4.17	23.61	12.28	18	*	2.78	1.91
4	2.78	18.40	11.27	20	*	2.08	1.53
5	1.74	16.67	10.09	22	*	1.91	1.14
6	1.39	15.63	8.79	24	*	1.74	1.05
7	1.22	12.15	7.85	26	*	1.39	*
8	0.69	11.11	6.93	28	*	1.04	*
10	*	7.64	6.09	30	*	0.69	*
12	*	5.56	4.76	35	*	*	*
				40	*	*	*

<sup>1</sup> Simulates 20 ton truck + impact

<sup>2</sup> Simulates 80,000 lb/ft railway load + impact

<sup>3</sup> 180,000 lbs. dual tandem gear assembly, 26 inch spacing between tires and 66 inch center-to-center spacing between fore and aft tires under a rigid pavement 12 inches thick + impact.

\* Negligible live load influence

**PRISM LOAD DETERMINATION**

Also referred to as the ‘dead’ load, the prism load is the pressure acting on the pipe by the weight of the soil column above a given section of the pipe. The following prism load columns are industry standards as referenced from Table 3, Deflection: The Pipe/Soil Mechanism UNI-TR-1-97, Uni-Bell PVC Pipe Association, Pg 13.

Table 3 Prism Load Soil Pressure (lbs/in <sup>2</sup> )					
Height of Cover (ft)	Soil Unit Weight (lb/ft <sup>3</sup> )				
	100	110	120	125	130
1	0.69	0.76	0.83	0.87	0.90
2	1.39	1.53	1.67	1.74	1.81
3	2.08	2.29	2.50	2.60	2.71
4	2.78	3.06	3.33	3.47	3.61
5	3.47	3.82	4.17	4.34	4.51
6	4.17	4.58	5.00	5.21	5.42
7	4.86	5.35	5.83	6.08	6.32
8	5.56	6.11	6.67	6.94	7.22
9	6.25	6.88	7.50	7.81	8.13
10	6.94	7.64	8.33	8.68	9.03
11	7.64	8.40	9.17	9.55	9.93
12	8.33	9.17	10.00	10.42	10.83
13	9.03	9.93	10.83	11.28	11.74
14	9.72	10.69	11.67	12.15	12.64
15	10.42	11.46	12.50	13.02	13.54
16	11.11	12.22	13.33	13.89	14.44
17	11.81	12.99	14.17	14.76	15.35
18	12.50	13.75	15.00	15.63	16.25
19	13.19	14.51	15.83	16.49	17.15
20	13.89	15.28	16.67	17.36	18.06
21	14.58	16.04	17.50	18.23	18.96
22	15.28	16.81	18.33	19.10	19.86
23	15.97	17.57	19.17	19.97	20.76
24	16.67	18.33	20.00	20.83	21.67
25	17.36	19.10	20.83	21.70	22.57
26	18.06	19.86	21.67	22.57	23.47
27	18.75	20.63	22.50	23.44	24.38
28	19.44	21.39	23.33	24.31	25.28
29	20.14	22.15	24.17	25.17	26.18
30	20.83	22.92	25.00	26.04	27.08
31	21.53	23.68	25.83	26.91	27.99
32	22.22	24.44	26.67	27.78	28.89
33	22.92	25.21	27.50	28.65	29.79
34	23.61	25.97	28.33	29.51	30.69
35	24.31	26.74	29.17	30.38	31.60
36	25.00	27.50	30.00	31.25	32.50
37	25.69	28.26	30.83	32.12	33.40
38	26.39	29.03	31.67	32.99	34.31
39	27.08	29.79	32.50	33.85	35.21
40	27.78	30.56	33.33	34.72	36.11
41	28.47	31.32	34.17	35.59	37.01
42	29.17	32.08	35.00	36.46	37.92
43	29.86	32.85	35.83	37.33	38.82
44	30.56	33.61	36.67	38.19	39.72
45	31.25	34.38	37.50	39.06	40.63
46	31.94	35.14	38.33	39.93	41.53
47	32.64	35.90	39.17	40.80	42.43
48	33.33	36.67	40.00	41.67	43.33
49	34.03	37.43	40.83	42.53	44.24
50	34.72	38.19	41.67	43.40	45.14

Note that the Prism Loads are calculated based upon the Marston Theory of Loads, developed by Professor Anson Marston, circa 1913, and is calculated using the formula:

$$P = \frac{\gamma_s * H}{144}$$

This formula determines the earth load on a flexible pipe and is regarded as a conservative approach to determining the dead load placed upon a buried flexible pipe.

At maximum burial depth of 19.30 feet, prism load = 14.51 psi

**BUCKLING PRESSURE (ALLOWABLE)**

- Where:  $q_a$  = Allowable buckling pressure (psi)  
 $h$  = Height of soil above top of pipe (in) = 231.60 in  
 $H$  = Depth of burial, feet, from ground surface to top of pipe  
 $B'$  = Empirical coefficient of elastic support  
 $E_b$  = Modulus of soil reaction for the bedding material (psi)  
 $E$  = Modulus of elasticity of the pipe material (psi)  
 $I$  = Moment of inertia of the pipe, per linear inch of pipe (in<sup>3</sup>)  
 $t$  = Pipe wall thickness (in)  
 $D$  = Mean Pipe Diameter (in)  $D = 8.077$  in

Solving for the Empirical coefficient of elastic support, given by Luscher in 1966, as referenced on Pg 113 of Moser, A.P., Buried Pipe Design. 2nd Ed., McGraw-Hill:

$$B' = \frac{4(h^2 + Dh)}{1.5(2h + D)^2} \qquad I = \left(\frac{t^3}{12}\right) = \left(\frac{\text{inches}^3}{\text{in}_{\text{linear}}}\right) =$$

$$B' = \frac{222037}{333153} = 0.666 \qquad I = \frac{0.0337}{12} = 0.0028$$

Using the Allowable Buckling Pressure Equation as shown in Moser, A.P., Buried Pipe Design. 2nd Ed., McGraw-Hill, Pg 112, and an initial factor of safety (SF) of 2.5, the Allowable Buckling Pressure is then:

$$q_a = \frac{1}{FS} * \sqrt{32 * R_w * B' * E_b * \left(E * \frac{I}{D^3}\right)} \qquad \text{Where,}$$

$$R_w = 1 - 0.33(h_w / h)$$

$$q_a = \frac{1}{2.5} \sqrt{\left[ 32 \right] \left[ 1 \right] \left[ 0.666 \right] \left[ 2000 \right] \left[ 400000 \frac{0.0028}{526.93} \right]}$$

$$q_a = 120.62 \quad \text{psi}$$

## **BUCKLING PRESSURE (INSTALLED CONDITION)**

Where:	$q_p$	=	Pressure applied to pipe under installed conditions (psi)
	$\gamma_w$	=	Specific Weight of Water = 0.0361 (pci)
	$\gamma_s$	=	Specific Weight of Soil (pcf)
	$W_c$	=	Vertical Soil Load on the pipe per unit length (lb/in)
	$L_L$	=	Live load as determined from chart
	$hw$	=	Height of Groundwater above pipe, typically = 0
	$D$	=	Mean Pipe Diameter (in) $D = 8.077$ in
	$t$	=	Pipe Wall Thickness (in) $t = 0.323$ in

The Vertical Soil Load can be calculated using Equation 6.6 of Uni-Bell's Handbook of PVC Pipe , Ch VI Superimposed Loads on Buried Pipe, Pg 183

$$W_c = H \times \gamma_s \times (D + t)$$

Where:  $\gamma_s = 106.9$  Value taken from: **Geotechnical Report**

$$W_c = \left[ 19.30 \right] \left[ 12 \text{ in/ft} \right] \left[ 106.90 \right] \left[ \frac{1 \text{ ft}^3}{1728 \text{ in}^3} \right] \left[ 8.40 \right]$$

$$W_c = 120.35 \text{ lb/in}$$

At Max Pipe Depth (H) of 19.30 ft

Using the Equation on Pg 114 of Moser, A.P., Buried Pipe Design. 2nd Ed., McGraw-Hill, Pressure Applied to Pipe under installed conditions at its deepest installed depth (Note, since  $hw = 0$ , the Water Buoyancy Factor ( $R_w$ ) = 1) is calculated to be:

$$q_p = \gamma_w h_w + R_w \left( \frac{W_c + L_L}{D} \right) \quad \text{and } L_L = 0 \quad R_w = 1 - 0.33(h_w / h)$$

$$q_p = 0.0361 \times 0 + 1 \times \left[ \frac{120.35}{8.077} \right]$$

$$q_p = 14.90 \text{ psi}$$

**Note: The pressure applied to the pipe under installed conditions is less than the Allowable Buckling Pressure of the specified pipe, (i.e..  $q_a > q_p$ ) therefore the design is acceptable for installation.**

## WALL CRUSHING CALCULATION

Where:	$D_o$	=	outside pipe diameter, in.	=	8.4 in
	$P_c$	=	Compressive stress or hydrostatic design basis (HDB). For typical PVC pipe assume 4,000 psi. For any other pipe material the HDB must be supplied by the pipe manufacturer.		
	$A$	=	surface area of the pipe wall, in. <sup>2</sup> /ft	=	0.323 in. <sup>2</sup> /ft
	$\gamma_s$	=	specific weight of soil, pcf,	=	106.9 pcf
	$H$	=	Depth of burial (ft) from ground surface to crown of pipe		

Using the Wall Crushing and Wall Thrust equations, as referenced in Plastic Pipe Design Manual published by Vylon Pipe, Pg 14 the Wall Crushing due to compressive stress can be found using the following:

$$P_c = \frac{T}{A} \quad \text{where T, Thrust, is calculated as } T = \frac{P_y D}{2}$$

Substituting the Thrust equation into the Wall Crushing equation:

$$P_c = \frac{\frac{P_y D}{2}}{A} = \frac{P_y D}{2A}$$

From the Marston Equation determining the Prism Load Calculation (See previous section on Prism Load), substitute the equation for  $P_y$ :

$$P_c = \frac{\frac{\gamma_s * H}{144} D}{2A} \quad \text{Rearranging this equation, it becomes: } 2AP_c = \frac{\gamma_s * H}{144} D$$

$$\text{And simplifies to: } 288AP_c = \gamma_s HD$$

Note that the Surface Area of the Pipe Wall,  $A$ , is per unit length in inches<sup>2</sup> per foot, a conversion factor (from feet to inches) of 12 must be applied, therefore,

$$24AP_c = \gamma_s HD$$

Solving for  $H$ , the equation becomes:

$$H = \frac{24 * P_c * A}{\gamma_s * D_o}$$

*(Continued on next page)*

Using this equation, and converting all units, solve for “height” of the soil column, or in other words, the depth of burial of the PVC pipe:

$$H = \frac{[24][4000][0.323 \times 12]}{106.9 \times 8.4} = 414.38$$

$$H = 414.38 \text{ feet}$$

**Note: The resulting Wall Crushing will occur at a greater depth than the deepest burial depth of the proposed SCS lines, therefore pipe design is acceptable.**



## DEFLECTION ANALYSIS: LEONHARDT'S ZETA FACTOR

The Leonhardt's Zeta Factor Equation can be calculated using Equation 7.32 of Uni-Bell's Handbook of PVC Pipe , Ch VII Design of Buried PVC Pipe, Pg 268

Where: Do = Pipe Outer Diameter, in = 8.400  
B = Trench Width, in, = 32.40 in  
E<sub>b</sub> = Modulus of soil reaction, bedding material (psi) = 2000  
E'<sub>n</sub> = Modulus of soil reaction for the in-situ soil (psi) = 2000

$$zeta = \frac{1.44}{f + [1.44 - f] \times \left[ \frac{E_b}{E'_n} \right]}$$

where,

$$f = \frac{\frac{B}{Do} - 1}{1.154 + 0.444 \left[ \frac{B}{Do} - 1 \right]}$$

$$f = \frac{2.857143}{2.420571} = 1.18036$$

Substituting f into the zeta equation:

$$zeta = \frac{1.44}{\left[ 1.180 \right] + \left[ 0.260 \right] \times \left[ 1.000 \right]}$$

The Leonhardt Zeta factor is then determined as: **1.000**

**PIPE STIFFNESS (Figure: 30 TAC §217.53(k)(3))**

Using Equation B.1, as directed in 30 TAC §217.53(k)(3), to Calculate the Pipe Stiffness:

$$PS = C \times RSC \times \left( \frac{8.337}{D} \right)$$

Where: PS = Pipe Stiffness, for SDR-26 PVC (psi) = 11: **115** psi  
C = Conversion factor = 0.8  
RSC = Ring Stiffness Constant  
D = Mean Pipe Diameter (in), D = 8.077 in

The RSC can be supplied by the manufacturer or calculated by rearranging Equation B.1

$$RSC = \frac{PS}{C \times \left( \frac{8.337}{D} \right)}$$

$$RSC = \frac{115}{0.825752}$$

$$RSC = 139.267$$

**PREDICTED PIPE DEFLECTION**

Using the Modified Iowa Equation, referenced and published by the Uni-Bell PVC Pipe association and found at <http://www.uni-bell.org/faq.html>, and Equation 14 of Deflection: The Pipe/Soil Mechanism UNI-TR-1-97, Uni-Bell PVC Pipe Association Pgs 17, the predicted pipe deflection can be calculated.

- Where: %ΔY/D = Predicted % vertical deflection under load  
 P = Prism Load, psi  
 K = Bedding angle constant, Assumed to = 0.096  
 W' = Live Load, psi, = 0 At max depth (ft) : 19.30  
 DR = Dimension Ratio= 26  
 E = Modulus of tensile elasticity of the pipe material, psi  
 E' = Modulus of Soil Reaction (zeta x Eb) = 2000.00  
 D<sub>L</sub> = Deflection Lag Factor = 1.5

And using the Modified Iowa Equation:

$$(\%) \frac{\Delta Y}{D} = \frac{(D_L KP + KW') \times 100}{[2E / (3(DR - 1)^3)] + 0.061 E'}$$

Where, Prism Load,  $P = \frac{\gamma_s * H}{144}$

and/or from previous chart, prism load = 14.51 psi

The Predicted Deflection is determined as:

$$(\%) \frac{\Delta Y}{D} = \frac{[[[1.5 \times 1.393] + 0] \times 100]}{\left[ \frac{800000}{46875} \right] + [0.061 \times 2000.00]} = 1.50 \%$$

**NOTE:** 1.50 < 5%, therefore pipe design is acceptable

A deflection lag factor of 1.0 is typical for new pipes. Over the life of the pipe, the pipe will tend to deflect. Therefore, 1.5 is a conservative factor for the 50 year life.

**PIPE STRAIN**

Pipe strain is also known as the elongation of the pipe over the original length of the pipe. Under normal loading conditions of the PVC pipe, the variable that affects the elongation or straining of the pipe stems from either the flexure or deflection (i.e.. bending) of the pipe within the bedding material (i.e. increased or excessive pipe deflection causing the pipe to elongate) or hoop stress within the pipe wall. Please note that pipe strain is not generally known to be the limiting performance factor during pipe failure. For this system, pipe deflection is limited to 5% for a SDR 26 pipe. This 5% deflection value is the industry accepted value placing the pipe within its straining limits. Therefore, as the calculated deflection above is shown to be less than 5%, the pipe and bedding class used in this system is within the acceptable straining limits for this pipe.

However, total Pipe strain is calculated as the combination of the before mentioned hoop stress and the maximum strain due to deflection. Both items are calculated below using Equations 15 and 16 found in Deflection: the Pipe/Soil Mechanism, UNI-TR-1-97, Published by the Uni-Bell PVC Pipe Association (Pgs 28-30):

- Where:  $\epsilon_h$  = Maximum Pipe Strain due to Hoop Stress, in/in  
P = Pressure on the pipe (Live + Prism Loads), psi  
E = Modulus of Elasticity of the Pipe, psi  
t = Pipe Wall thickness (in) = 0.323  
D = Pipe Diameter, Outer (in) = 8.400

$$\epsilon_h = \frac{PD}{2tE}$$

Using the maximum cover for both live loads and prism loads as well as the previous unit weight of the soil:

$$\epsilon_h = \frac{[ 0.00 + 14.51 ] \times 8.400}{2 \times 0.323 \times 400,000} = 4.717E-04 \frac{\text{in}}{\text{in}}$$

*(Continued on following page)*

Where:  $\epsilon_f$  = Maximum Pipe Strain due to Ring Deflection, in/in  
 $\Delta Y$  = Change in vertical pipe diameter under load, in, (numerator in the deflection equation, but in decimal form)  
 $t$  = Pipe Wall thickness (in) = 0.323  
 $D$  = Pipe Diameter, Outer (in) = 8.400  
 $DR$  = Dimension Ratio, PVC Pipe = 26

$$\epsilon_f = \frac{t}{D} \left[ \frac{3\Delta Y / D}{1 - 2\Delta Y / D} \right] = \frac{1}{DR} \left[ \frac{3\Delta Y}{D - 2\Delta Y} \right]$$

$$\epsilon_f = \frac{0.323}{8.400} \times \frac{626.832}{8.400 - 417.888} = -0.05886 \frac{\text{in}}{\text{in}}$$

$$\epsilon_{total} = -0.0584 \frac{\text{in}}{\text{in}}$$

## **TCEQ PIPE BEDDING AND TRENCHING REQUIREMENTS (30 TAC 217.54)**

**\*\*These notes are provided in the Construction Documents on Plan Sheet C25\*\***

### **a. Pipe Embedment**

1. A rigid pipe must be laid with the adequate bedding, haunching, and initial backfill to support the anticipated load. The bedding classes that are allowed are A, B, or C, as described in American Society for Testing and Materials (ASTM) C 12, American National Standards Institute (ANSI) A 106.2, Water Environment Federation Manual of Practice No. 9 or American Society of Civil Engineers (ASCE) MOP 37.
2. A flexible pipe must be laid with the adequate bedding, haunching, and initial backfill to support the anticipated load. The bedding classes that are allowed are IA, IB, II, or III, as described in ASTM D-2321 or ANSI K65.171.
3. Debris, large clods, or stones that are greater than six inches in diameter, organic matter, or other unstable materials are prohibited as bedding, haunching, or initial backfill.
4. Backfill must not disturb the alignment of a collection system pipe.
5. If trenching encounters significant fracture, fault zones, caves, or solutional modification to the rock strata, an owner must halt construction until an engineer prepares a written report detailing how construction will accommodate these site conditions.

### **b. Compaction.**

1. Compaction of an embedment envelope must meet the manufacturer's recommendations for the collection system pipe used in a project.
2. Compaction of an embedment envelope must provide the modulus of soil reaction for the bedding material necessary to ensure a wastewater collection system pipe's structural integrity as required by §217.53 of this title (relating to Pipe Design).
3. The placement of the backfill above a pipe must not affect the structural integrity of a pipe.

### **c. Envelope Size.**

1. A minimum clearance of 6.0 inches below and on each side of the bell of all pipes to the trench walls and floor is required.
2. The embedment material used for haunching and initial backfill must be installed to a minimum depth of 12 inches above the crown of a pipe.

d. Trench Width.

1. The width of a trench must allow a pipe to be laid and jointed properly and must allow the backfill to be placed and compacted as needed.
2. The maximum and minimum trench width needed for safety and a pipe's structural integrity must be included in the report.
3. The width of a trench must be sufficient to properly and safely place and compact haunching materials.
4. The space between a pipe and a trench wall must be wider than the compaction equipment used in the pipe zone.

**TRENCH CROSS-SECTION (30 TAC 217.54)**

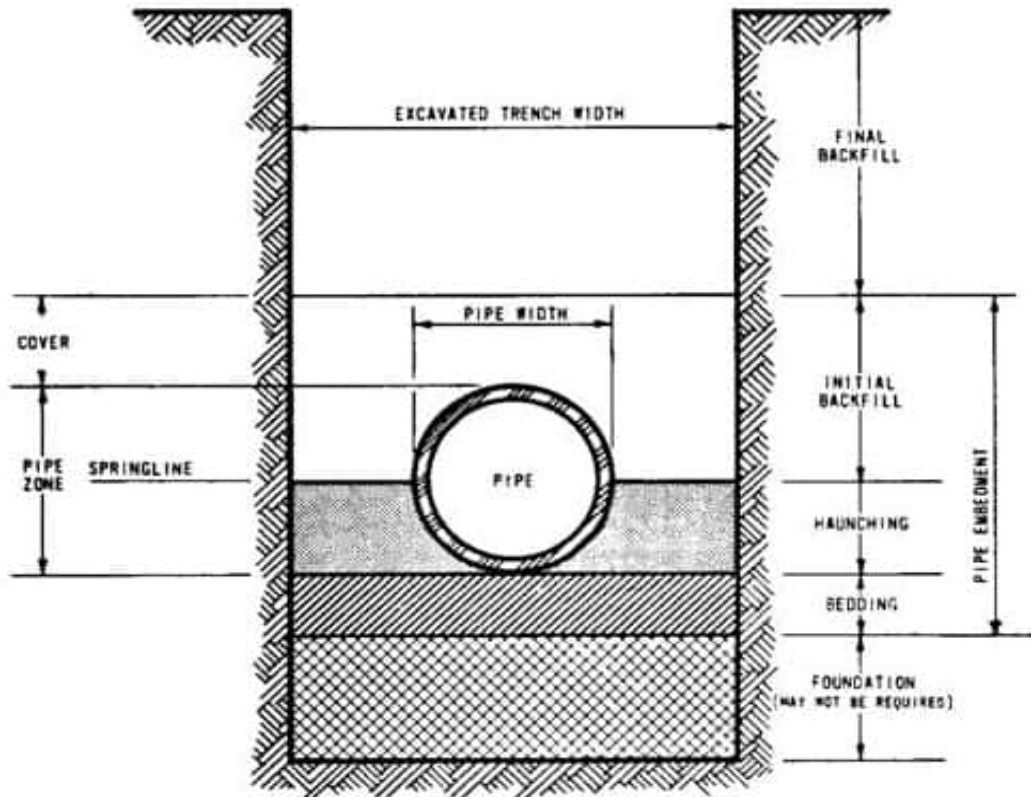

**NOTE:**

Trenching Details along with 30 TAC 217.54 are annotated in the Construction Documents/Plan Sheets on [Sheet C25](#).

## MANHOLE SPECIFICATIONS

### 30 TAC 217.55 Requirements with design comments:

- a. An owner must include manholes in a wastewater collection system at:
  1. All points of change in alignment, grade, or size;
  2. At the intersection of all pipes; and
  3. At the end of all pipes that may be extended at a future date.
- b. Manholes placed at the end of a wastewater collection system pipe that may be extended in the future must include pipe stub outs with plugs. **(Self explanatory, see item a above)**
- c. A clean-out with watertight plugs may be installed in lieu of a manhole at the end of a wastewater collection system pipe if no extensions are anticipated. **(Self explanatory, clean outs not used in-lieu of manholes)**
- d. Cleanout installations must pass all applicable testing requirements outlined for gravity collection pipes in §217.57 of this title (relating to Testing Requirements for Installation of Gravity Collection System Pipes). **(Self explanatory, see Item c above)**
- e.

A manhole must be made of monolithic, cast-in-place concrete, fiberglass, pre-cast concrete, high-density polyethylene, or equivalent material that provides adequate structural integrity. **See the Pre-Cast Manhole Details following these construction notes)**
- f. The use of bricks to adjust a manhole cover to grade or construct a manhole is prohibited. **(Self explanatory, See Details following these notes)**
- g. Manholes may be spaced no further apart than the distances specified in the following table for a wastewater collection system with straight alignment and uniform grades, unless a variance based on the availability of cleaning equipment that is capable of servicing greater distances is granted by the executive director. **(Manholes are spaced no greater than 400 L.F. per San Antonio Water Systems specifications)**

<b>Pipe Diameter</b>	<b>Maximum Manhole</b>
6-15	500
18-30	800
36-48	1000
54 or larger	2000



h. Tunnels are exempt from manhole spacing requirements because of construction constraints. **(Self explanatory and not applicable)**

- i. An intersection of three or more collection pipes must have a manhole. **(Self explanatory and maintained throughout the design of the SCS)**
- j. A manhole must not be located in the flow path of a watercourse, or in an area where ponding of surface water is probable. **(Self explanatory and maintained throughout the design of the SCS)**
- k. The inside diameter of a manhole must be no less than 48 inches. A manhole diameter must be sufficient to allow personnel and equipment to enter, exit, and work in the manhole and to allow proper joining of the collection system pipes in the manhole wall. **(See Manhole Details following these notes)**
- l. Manholes must meet the following requirements for covers, inlets, and bases.

- 1. Manhole Covers

- A.

- A manhole where personnel entry is anticipated requires at least a 30 inch diameter clear opening. **(Covers to have 32” Openings per SAWS Specifications and Notes on Sheet C33)**

- B. A manhole located within a 100-year flood plain must have a means of preventing inflow. **(Self explanatory but not applicable for this project)**

- C. A manhole cover construction must be constructed of impervious material. **(Self explanatory, See Manhole Details following these construction notes)**

- D. A manhole cover that is located in a roadway must meet or exceed the American Association of State Highways and Transportation Officials standard M-306 for load bearing. **(Self explanatory, See Manhole Details)**

- 2. Manhole Inverts

- A. The bottom of a manhole must contain a U-shaped channel that is a smooth continuation of the inlet and outlet pipes. **(Self explanatory, see SAWS Details Sheet C33)**

- B. A manhole connected to a pipe less than 15 inches in diameter must have a channel depth equal to at least half the largest pipe's diameter **(Self explanatory, see SAWS Details Sheet C33)**

- C. A manhole connected to a pipe at least 15 inches in diameter but not more than 24 inches in diameter must have a channel depth equal to at least three-fourths of the largest pipe's diameter **(Self explanatory, but not applicable for this project)**

- D. A manhole connected to a pipe greater than 24 inches in diameter must have a channel depth equal to at least the largest pipe's diameter **(Self explanatory, but not applicable for this project).**

- E. A manhole with pipes of different sizes must have the tops of the pipes at the same elevation and flow channels in the invert sloped on an even slope from pipe to pipe. **(Self explanatory and maintained throughout the design of the SCS)**
- F. A bench provided above a channel must slope at a minimum of 0.5 inch per foot. **(Self Explanatory)**
- G. An invert must be filleted to prevent solids from being deposited if a wastewater collection system pipe enters a manhole higher than 24 inches above a manhole invert. **(Self Explanatory, see SAWS Details Sheet C33 for a drop manhole)**
- H. A wastewater collection system pipe entering a manhole more than 24 inches above an invert must have a drop pipe. **(Self Explanatory, see SAWS Details Sheet C33 for a drop manhole)**
- m. The inclusion of steps in a manhole is prohibited. **(Self Explanatory, steps are not included in SAWS manhole Details)**
- n. Connections. A manhole-pipe connection must use watertight, size-on-size resilient connectors that allow for differential settlement and must conform to American Society for Testing and Materials C-923. **(Self Explanatory, see SAWS Details Sheet C33 and General Notes)**
- o. Venting. An owner must use an alternate means of venting if manholes are at more than 1,500 foot intervals and gasketed manhole covers are required for more than three manholes in sequence. Vents must meet the following requirements: **(Self Explanatory)**
  - 1. Vent design must minimize inflow;
  - 2. Vents must be located above a 100-year flood event elevation; and
  - 3. Tunnels must be vented in compliance with this subsection.
- p. Cleanouts. The size of a cleanout must be equal to the size of the wastewater collection system main. **(Self Explanatory)**

**Precast Manhole Information:**

**Hanson Pipe and Precast**

Hanson Building Products West  
 300 E John Carpenter Freeway  
 11th floor  
 Irving, TX 75062  
 972.653.5500

**San Antonio** Metro Area Contact:  
 210.661.2351  
 866.426.7661

**Precast Manholes**

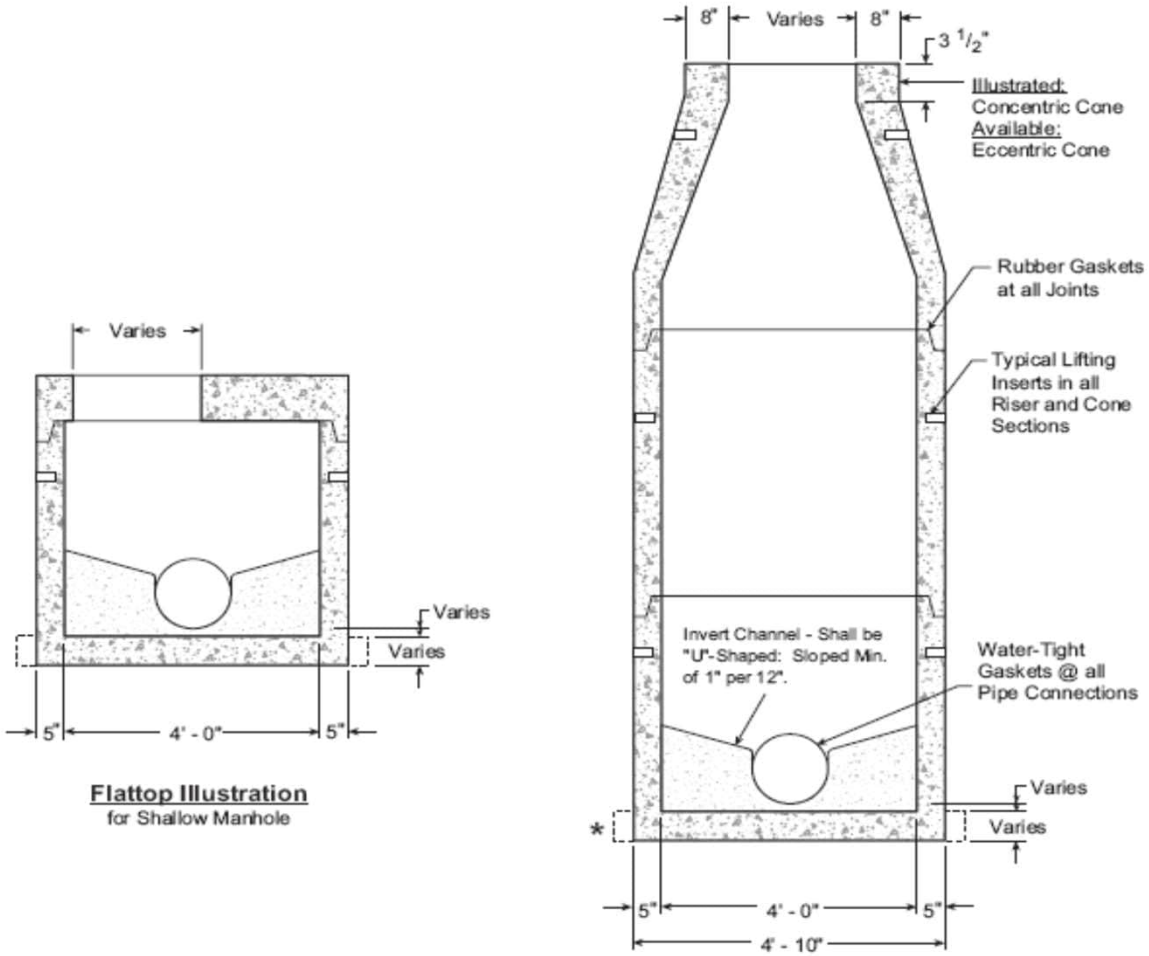

**Flattop Illustration**  
for Shallow Manhole

**Section View**  
4' I.D. Manhole - Regular Base  
with Reducing Cone

**Materials & Features**

HOLES AS SPECIFIED: Max diameter = 32"  
 CONCRETE: 5,000 PSI, 28 day strength.  
 REINFORCING: Meets or exceeds ASTM C478 requirements.  
 Average weight of 24" depth base w/8" invert = 4,500 lbs.  
 Estimated weight of riser and cone sections = 870 lbs. / vt. ft.

\* - Extended base is available to meet local requirements.

In the event a boot is loose contact your Hanson representative to resolve.

*"Manufactured to your specifications."*

**-No Scale-**  
 All dimensions subject to allowable specification tolerances.

TITLE	PLANT	STATE	SECTION/PAGE	DATE	
<b>4' I.D. Manhole</b> Regular Base w/ Reducing Cone	All Plants	TX	5.5	07-01-06	

## Precast Manholes

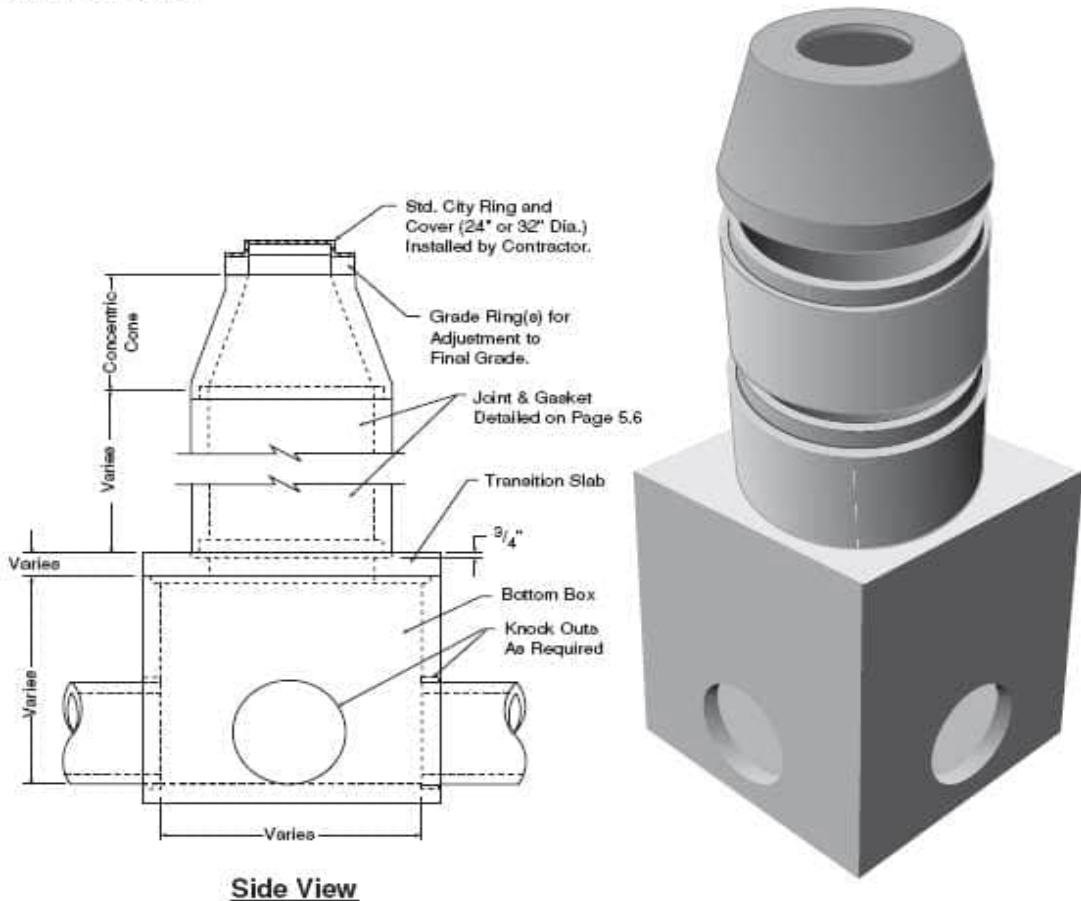

**Side View**

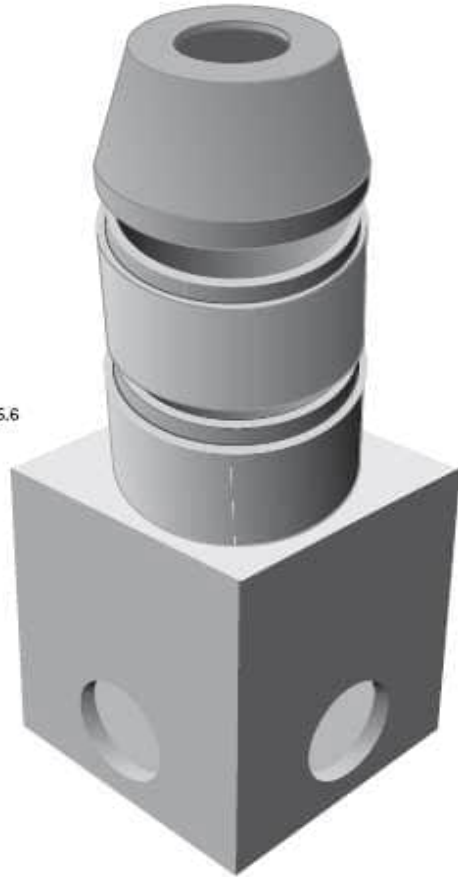

**Isometric View**

### Materials & Features

CONCRETE: 5,000 PSI in 28 days.  
 REINFORCING STEEL: per ASTM A-615 / A-185  
 REINFORCING to meet AASHTO HS 20-44 Loading.  
 BASE DESIGN EQUAL TO OR EXCEEDS ASTM C-357  
 RISER DESIGN EQUAL TO OR EXCEEDS ASTM C-478  
 In the event a boot is loose contact your Hanson representative to resolve.

-No Scale-  
 All dimensions subject to allowable specification tolerances.

TITLE	PLANT	STATE	SECTION/PAGE	DATE	
Type "C" Manhole	Houston San Antonio	TX	5.11	07-01-06	



## Precast Manholes

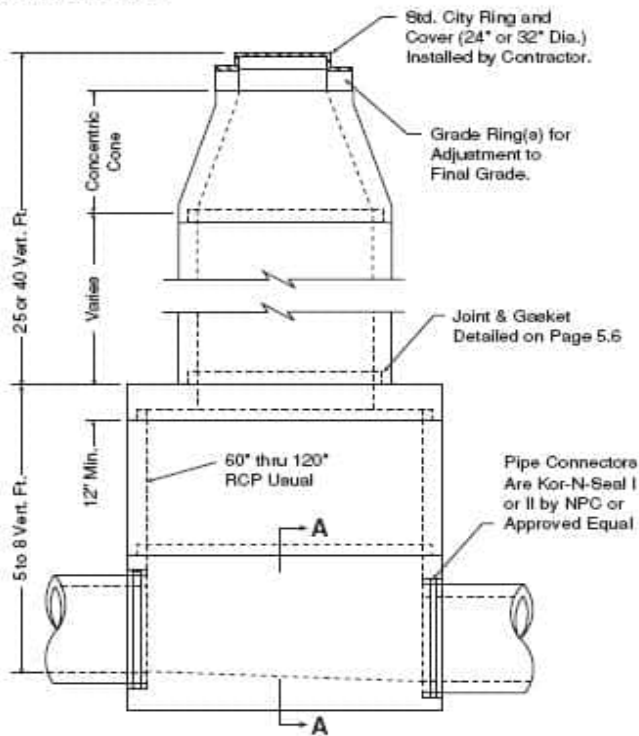

w/ Precast Base

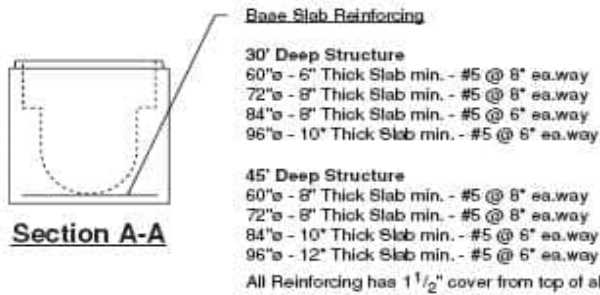

Section A-A



Isometric View

### Materials & Features

CONCRETE: 5,000 PSI in 28 days.  
 REINFORCING STEEL: per ASTM A-615, Grade 60.  
 REINFORCING to meet AASHTO HS 20-44 Loading.  
 DESIGN EQUAL TO OR EXCEEDS ASTM C-478  
 In the event a boot is loose contact your Hanson representative to resolve.

### Note:

- Inverts shall be specifically sized for connecting pipes; and shall be U-Shaped with the min. depth 3/4 of the largest pipe diameter.

-No Scale-  
 All dimensions subject to allowable specification tolerances.

TITLE	PLANT	STATE	SECTION/PAGE	DATE	
30 & 45 Ft. Depth 60" thru 96" Large Base Manhole	Houston San Antonio	TX	5.10	07-01-06	



## ENGINEERING DESIGN REPORT – SUPPLEMENT

This project will be constructed using SAWS Standard Specifications for Construction. These SAWS requirements are in strict accordance with 30 TAC requirements and comply with the latest provision of the “Excavation, Trenching, and Shoring of OSHA Safety and Health Regulations for Construction”. These standards outline regulations for testing and inspections to adhere to safety considerations as outlined in 30 TAC § 217.10(e)(13). It is not anticipated that odor control will be necessary based on the quantity of sewage flows generated with vented manholes planning to be installed. SAWS standards for providing odor control measures on lateral connections begin for main size exceeding 21 inches. Testing of hazardous fumes and toxic gases and locating existing underground utilities prior to digging reduces risks associated with explosions. Manhole entrances shall be a minimum of 30” wide to ensure no safety issues with entering and exiting the manholes. Working areas and trenches will be inspected prior to the start of each shift or after a rainfall event. OSHA standards outline access and egress to and from all trenches over 4 feet in depth.



Estancia Ranch, Unit 3  
Organized Sewage Collection System Plan



**ENGINEERING DESIGN REPORT**  
**ATTACHMENT A – UTILITY SERVICE AGREEMENT**

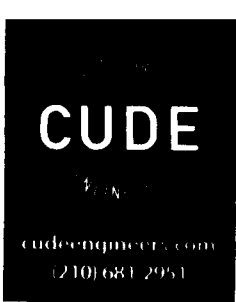

**UTILITY SERVICE AGREEMENT**

STATE OF TEXAS                   §  
  §  
COUNTY OF BEXAR               §

**Doc# 20210263974 09/22/2021 9:34AM Page 1 of 22 Lucy Adame-Clark, Bexar County Clerk**

This Utility Service Agreement (“Agreement”) is entered into by and between the San Antonio Water System Board of Trustees, through Resolution Number 2020-133, acting by and through its President/Chief Executive Officer (“SAWS”) and Meritage Homes of Texas, LLC (“Developer”) together the Parties (“Parties”).

**Recitals**

**Whereas**, Developer has requested that SAWS provide Water and Wastewater service (the “Services”) to an approximate 173.3-acre tract of land, (the “Specht Tract” or “Tract”), which is located inside SAWS water CCN, inside SAWS wastewater CCN, and does require SAWS’ financial participation in the development of infrastructure through oversizing or impact fee credits, therefore, Board action is required; and

**Whereas**, the Tract is located over the Edwards Aquifer Recharge or Contributing Zone, which is located within the 5-mile Awareness Zone of Camp Bullis, such Tract being more particularly described in Attachment VI hereto, as accepted by SAWS; and

**Whereas**, SAWS desires to provide the Services to the Developer pursuant to this Agreement, the SAWS Utility Service Regulations, and all applicable local, state, and federal regulations, as amended.

**Now Therefore, The Parties Hereto Agree To The Following Terms and Conditions:**

**1.00 Interpretation of Agreement.**

1.01 The Parties acknowledge that the Services contemplated by this Agreement shall be provided in accordance with the SAWS Utility Service Regulations, Design Criteria, Schedules, Attachments and Instruments thereto, as amended (together “USR”). In the event the specific terms of this Agreement are in conflict with the USR, the specific terms of this Agreement shall apply. The above notwithstanding, for the specific conflicting terms to prevail, the conflict must be expressly noted in the Agreement. The Parties further acknowledge that this Agreement is subject to future acts of the City Council of the City of San Antonio with respect to the adoption or amendment of impact fee ordinances/resolutions.

1.02 The Parties agree that the purpose of this Agreement is the reservation of the designated water supply and /or wastewater discharge capacity for the Tract. Any rights that the Developer claims arise under Chapter 245, Texas Local Government Code, that are related to this Agreement shall comply with the Unified Development Code Article IV, Division 1, Chapter 35-410 and applicable requirements in Article VII, Division 2 *Vested Rights*. If Developer intends to rely on this USA as its application for the purposes of vested rights under Chapter 245, then please contact

Development Services Department, Land Entitlement team at 210-207-1111 or 1901 S. Alamo, San Antonio, TX. 78204. In no event shall the Utility Service Regulations replace or conflict with the City's Unified Development Code, Article IV, Division 1, Chapter 35-410 and applicable requirements in Article VII, Division 2 *Vested Rights*.

**2.00 Obligation Conditioned.**

The obligation of SAWS to provide the Services is conditioned upon present rules, regulations and statutes of the United States of America and the State of Texas and any court order that directly affects the SAWS' Regional Water Production and Distribution System and/or Regional Wastewater Transportation and Treatment System and/or the utility infrastructure directly servicing the Tract. Developer acknowledges that if the rules, regulations and statutes of the United States of America and/or the State of Texas that are in effect upon the execution date of this Agreement are repealed, revised or amended to such an extent that SAWS becomes incapable of, or prevented from, providing the Services, then no liability of any nature is to be imposed upon SAWS as a result of SAWS' compliance with such legal or regulatory mandates. SAWS agrees that it will use its best efforts to prevent the enactment of such legal or regulatory mandates.

**3.00 Term.**

3.01 The term of this Agreement shall be seven (7) years from the Effective Date if the Developer complies with the requirements set out in G.C. 19.00 (attached) within the time period therein stated. This Agreement shall automatically expire if Developer fails to comply with the requirements of G.C. 19.00 within the time period therein provided. The term of this Agreement may be extended to fifteen (15) years from the Effective Date, if Developer complies with the requirements to extend the term set forth in G.C. 19.00 within the time period therein stated. Certain obligations of SAWS (described in Section 3.03 below) may survive the expiration of the term of this Agreement, to the extent that Developer has (i) paid all applicable impact fees for the Services at the then-current rate, and (ii) complied with all On-Site and Off-Site utility infrastructure requirements of this Agreement (described in the Special Conditions), including over-sizing requirements.

3.02 To the extent that SAWS' obligations do not survive the expiration of this Agreement, Developer understands and agrees that a new Utility Service Agreement must be entered into with SAWS to receive the Services for the development project that is the subject of this Agreement.

3.03 To the extent that Developer timely pays all applicable impact fees and complies with all On-Site and Off-Site utility infrastructure requirements prior to the expiration of this Agreement, the following obligations will survive expiration of this Agreement:

- (i) SAWS' recognition of the EDUs referenced as the subject of this agreement as Guaranteed Capacity.
- (ii) SAWS' continued recognition of impact fee credits previously earned by the Developer pursuant to Sections 15.8 and 15.9 of the USR.

- (iii) SAWS' continued provision of the Services to retail customers located in the Tract, so long as such customers pay for the services and comply with the regulations applicable to individual customers.

**4.00 Entire Agreement.**

The following documents attached hereto and incorporated herein are as fully a part of this Agreement as if herein repeated in full, together with this Agreement, comprise the Agreement in its entirety:

Attachment I:	General Conditions
Attachment II:	Special Conditions
Attachment III:	Description of Proposed Water and/or Wastewater Infrastructure
Attachment IV:	Board Summary & Recommendation and Resolution (if necessary)
Attachment V:	Developer Water and/or Wastewater Master Plan (if necessary)
Attachment VI:	Engineering Study Including Description of the Tract
Attachment VII:	Lift Station & Force Main Supplemental Agreement (if necessary)
Attachment VIII:	Water Recycling and Conservation Plan (if necessary)

Any of the above attachments that are created and submitted by the Developer as an attachment to this USA shall be limited to providing relevant engineering, planning or managing information for the purposes of setting aside or reserving water and/or wastewater service capacity as specified in the body of this USA, the General Conditions and the Special Conditions. Developer agrees that it will not attempt to rely on, and SAWS does not authorize, any of the contents of any attachments created and submitted by the Developer as a basis for claiming rights under Chapter 245 of the Texas Local Government Code, except as specifically required by Section 1.02 of this USA.

Developer understands that this Agreement, including, its General Conditions, Special Conditions and Attachments, is subject to the Texas Public Information Act; and, therefore, agrees that it will not claim that any of the information contained herein is subject to any third party exception under that Act.

**5.00 Developer's Obligations.**

The Developer acknowledges and agrees that the capacity provided by this Agreement runs with the land and shall be an appurtenance to the Tract. The Developer acknowledges that recordation of this Agreement in the Real Property Records of the County in which the Tract is located within three (3) years of the Effective Date of this Agreement is required; otherwise, this Agreement will automatically terminate. Developer shall record the Agreement and the delivery of a recorded copy to the Director within three (3) years of the Effective date of this Agreement or before any transfer of property or EDUs as specified in G.C. 20.00, whichever is sooner, is required. The Developer shall maintain records of EDU's remaining on the Tract pursuant to the approved Developer Master Plan. Developer shall provide SAWS with such records upon SAWS written request.

**6.00 Indemnity.**

**TO THE EXTENT ALLOWED BY LAW AND TEXAS CONSTITUTION, THE DEVELOPER FURTHER AGREES TO DEFEND, INDEMNIFY AND HOLD HARMLESS SAWS AND ITS SUCCESSOR AND ASSIGNS FROM THE CLAIMS OF THIRD PARTIES ARISING OUT OF SAWS' RECOGNITION OF THE TRANSFER OF CAPACITY UNDER THIS AGREEMENT TO DEVELOPER'S SUBSEQUENT PURCHASERS, SUCCESSORS AND ASSIGNS.**

**7.00 Notices.**

Any notice, request, demand, report, certificate or other instrument which may be required or permitted to be furnished to or served upon the parties shall be deemed sufficiently given or furnished or served if in writing and deposited in the United States mail, registered or certified, return receipt requested, addressed to such party at the address set forth below:

**IF TO SAN ANTONIO WATER SYSTEM:**

**SAN ANTONIO WATER SYSTEM  
POST OFFICE BOX 2449  
SAN ANTONIO, TEXAS 78298-2449  
ATTN: TRACEY B. LEHMANN, P.E., DIRECTOR, DEVELOPMENT ENGINEERING**

**IF TO DEVELOPER:**

**Meritage Homes of Texas, LLC  
2272 W Bitters Road, Suite 200  
San Antonio, TX 78248  
Attn: Brian Otto**

**8.00 Severability.**

If for any reason any one or more paragraph of this Agreement are held legally invalid, such judgment shall not prejudice, affect impair or invalidate the remaining paragraphs of the Agreement as a whole, but shall be confined to the specific sections, clauses, or paragraphs of this contract held legally invalid.

**9.00 Effective Date.**

The Effective Date of this Agreement shall be the date signed by the authorized representative of the San Antonio Water System.

**10.00 Ownership.**

By signing this Agreement the Developer represents and warrants that it is the owner of the Tract or has the authority of the Tract owner to develop the area. Any misrepresentation of authority or ownership by Developer shall make this Agreement voidable by SAWS. If the Developer does not own the Tract, then the Developer must provide documentation from the owner of the Tract to show that Developer has the proper authority to develop the Tract.

ACCEPTED AND AGREED TO IN ALL THINGS:

San Antonio Water System  
Signature: [Signature]  
Print Name: Robert R. Puente  
Title: President/Chief Executive Officer  
Date: 09-08-2021

Developer  
Signature: [Signature]  
Print Name: Brian Otto  
Title: Vice President of Land Acquisition and Development  
Date: 7-28-21

ACKNOWLEDGEMENTS

STATE OF TEXAS, COUNTY OF BEXAR

§

BEFORE ME, the undersigned Notary Public, on this day personally appeared Brian Otto known to me to be the person whose name is subscribed to the foregoing instrument and that he has executed the same as Vice President of Land Acquisition and Development for the purposes and consideration therein expressed and in the capacity therein stated.

GIVEN UNDER MY HAND AND SEAL OF OFFICE this 28<sup>th</sup> day of July, 2021.

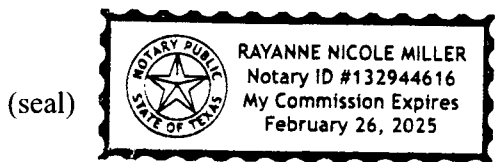

[Signature]  
Notary Public

STATE OF TEXAS, COUNTY OF BEXAR

§

BEFORE ME, the undersigned Notary Public, on this day personally appeared Robert R. Puente known to me to be the person whose name is subscribed to the foregoing instrument and that he has executed the same as President/CEO for the purposes and consideration therein expressed and in the capacity therein stated.

GIVEN UNDER MY HAND AND SEAL OF OFFICE this 9 day of September 2021.

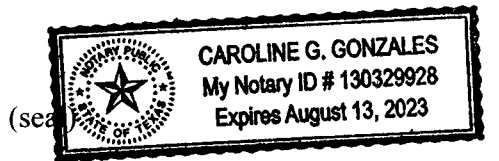

[Signature]  
Notary Public

**GENERAL CONDITIONS OF THE UTILITY SERVICE AGREEMENT**

**G.C.1.00 Definitions.**

**G.C.1.01 Developer.**

Owner of the tract, his subsequent purchasers, successors, and/or assigns.

**G.C.1.02 Director of Development Engineering.**

The Director of Development Engineering of the San Antonio Water System or his/her designated representative.

**G.C. 1.03 Definition of Terms.**

Unless defined in the Utility Service Agreement (the "Agreement"), the terms used in this General Conditions of the Utility Service Agreement (the "General Conditions") shall have the same definitions and meaning as those set out in Chapter 2, Definitions, of the Utility Service Regulations ("USR"). In the event a term is specifically defined in the General Conditions, and the definition is in conflict with that found in the USR, and such conflict is acknowledged in the General Conditions, the definition set out in the General Conditions shall apply.

**G.C.2.00 Required Submittals.**

If determined to be necessary by the Director of Development Engineering ("Director"), the Developer hereby agrees to submit the following documents prior to the execution of the Agreement: Developer Master Plan, Developer Utility Layout, Water Recycling and Conservation Plan, and Engineering Report. The Parties agree that such documents are included instruments to the Agreement. The submittal of such documents is a condition precedent to plat recordation and initiation of Services. Developer shall modify such documents as may be reasonably required by the Director. Such documents shall be updated as required by the Director and the USR.

**G.C.3.00 Dedication to SAWS.**

The Developer agrees to dedicate, grant, and convey to SAWS all rights, title and interest of Developer in both the Off-Site and On-Site utility infrastructure that the Developer is required to construct under the Special Conditions of the Utility Service Agreement (the "Special Conditions"), and to dedicate, grant, and convey to SAWS easements for such utility infrastructure. Upon written acceptance of Off-Site and On-Site utility infrastructure by SAWS, the infrastructure shall be owned, operated and maintained by SAWS.

**G.C.4.00 Design and Construction Requirements.**

The design and construction of all Off-Site and On-Site utility infrastructure shall, at a minimum, comply with the requirements established by SAWS, including the USR, the City of San Antonio, the County of Bexar, the State of Texas, and any agency thereof with jurisdiction, including but not limited to the Texas Commission on Environmental Quality and the Texas Department of Health. Off-Site and On-Site utility infrastructure shall be constructed under the inspection of SAWS. Provision of the Services to the Tract shall not commence until the Director has accepted and approved Off-Site and On-Site utility infrastructure in writing.

**G.C.5.00 Joint Venture Agreements.**

In the event the Developer enters into a Joint Venture Agreement covering the costs for supplying the Services to the Tract, the Developer shall send a copy of such agreement to the attention of the Director.

**G.C.6.00 Assignment.**

This Agreement may not be assigned in whole or in part; however, Developer may assign, convey or transfer EDU capacity ("EDU capacity transfer") to buyers of portions of the Tract in accordance with the terms in G.C. 20.00.

General Conditions of USA

USA-23714 Specht Tract

07/27/21, Page 1 of 4

Preparer's Initials 

**G.C.7.00 Event of Foreclosure.**

In the event Developer's interest in the Tract described in Attachment VI are extinguished by an act of foreclosure, and the foreclosing party has supplied sufficient evidence to SAWS that they are the successor in interest to the Tract as a result of such foreclosure, and that there are no lawsuits pending concerning the Tract, SAWS shall consider the foreclosing party a successor in interest if the foreclosing party executes a utility service agreement with SAWS after the Director determines that the execution of such an agreement will not be adverse to SAWS' interest.

**G.C.8.00 Payment for Provision of Utility Service.**

In the event payment for the Services provided to a subdivision plat within the Tract is not billed by SAWS, the amount of the monthly fees for the provision of the Services will be those charged to the various customer classifications as set by City Ordinances, with the billing and collection thereof on behalf of SAWS, being the responsibility of the billing utility purveyor. To facilitate this arrangement, Developer is to insert into any utility agreement with whatever utility purveyor is to bill for utility services to a subdivision plat within the Tract, a provision requiring said purveyor to enter into a Contract with SAWS to bill and collect SAWS' monthly utility services fees and transmit said fees to SAWS. The billing utility purveyor shall advise customers that delinquent non-payment of any of SAWS' fees will result in interruption and/or termination of the Services provided by SAWS, in accordance with applicable interruption and termination policies and procedures, as amended. SAWS shall not be obligated to provide the Services to any plat within the Tract unless and until the utility purveyor has executed a contract with SAWS to provide for the billing and collection of the Services provided by SAWS.

**G.C.9.00 Enforcement of Industrial Waste Ordinance if Required by SAWS.**

The Developer shall cause to be recorded in the Deed and Plat Records of the counties in which the Tract is located, a restrictive covenant covering the entire Tract. This restrictive covenant shall run with the land in the Tract described in Attachment VI. Such covenant shall contain language expressly granting to SAWS the right, should SAWS so elect, to enforce and or otherwise pursue to the extent provided at law or in equity, the provisions of the City's Industrial Waste Ordinance No. 57214, as amended or as may be amended (codified as Chapter 34, Article V, Division 3 of the City Code). SAWS' right shall include, to the extent provided at law or in equity, the right to inspection, sampling and monitoring of the collection system to assure ordinance compliance.

Recordation of the Covenant shall be a condition precedent for SAWS' provision of the Services to any portion of said Tract.

**G.C.10.00 Oversizing.**

Developer must pay for all mains and other utility facilities needed to serve the Tract. SAWS may require the installation of oversized water mains and wastewater mains and related facilities. SAWS' requirements for oversizing, if any, are set forth in the Special Conditions. SAWS will execute a trilateral contract with Developer and a contractor for the construction of oversized facilities. Contracts for the construction of oversized facilities must be competitively bid as required by law. All oversizing shall be done in accordance with the USR.

**G.C.11.00 Off-Site /On-Site Facilities.**

Developer shall construct and install all required Off-Site and On-Site utility infrastructure in accordance with the USR and Special Conditions, at no cost to SAWS. Any specific requirements related to the facilities are set forth in the Special Conditions.

**G.C.12.00 Impact Fee Payment.**

Developer agrees that the Agreement does not constitute an assessment of impact fees. Developer agrees to pay all applicable impact fees at the time and in the amount prescribed by ordinance or resolution of the City Council of the City of San Antonio and the USR, as amended. An estimate of the impact fees for the development Tract is provided in the Special Conditions. The estimate does not constitute an assessment of impact fees, and the amount of impact fees is subject to change by the City Council of the City of San Antonio as provided by law.



**G.C.13.00 SAWS' Obligation to Supply Service.**

To the extent that Developer pays all applicable impact fees and complies with all Off-Site and On-Site utility infrastructure requirements, Developer shall be entitled to the permanent use and benefit of the Services and is entitled to receive immediate service from any existing facilities with actual capacity to serve the development for which impact fees were paid, subject to compliance with other valid regulations. If, after collecting the impact fees, there is no actual capacity in existing facilities to provide the Services, SAWS will provide the Services within a reasonable period of time not to exceed five (5) years, as prescribed by Chapter 395 of the Local Government Code, as amended. In the event Services are required by Developer earlier than the five (5) year period, Developer and SAWS may agree that Developer may construct or finance the capital improvements or facility expansions required to provide Services, and the costs incurred or funds advanced will be credited against impact fees otherwise due from the new development or reimbursed to Developer from impact fees paid from other new developments that will use such capital improvements or facility expansions, which fees shall be collected and reimbursed to Developer at the time the other new development records its plat.

**G.C.14.00 Facility Design and Construction.**

The Developer shall design and construct all On-Site and Off-Site utility infrastructure described in the Special Conditions, including any oversizing, in accordance with the USR and all applicable local, state and federal requirements. Developer further recognizes that SAWS' approval in all respects as to facility right-of-way adequacy, location, size, grade and invert elevation is a condition precedent to any further obligation of SAWS. Specific design and construction requirements are set forth in the Special Conditions.

**G.C.15.00 Use of Capacity by SAWS.**

Developer understands that capacity in Off-Site and On-Site utility infrastructure resulting from the Agreement for the Tract may be utilized by SAWS for other tracts requesting service from SAWS. SAWS shall keep accurate records of the capacity provided to the Tract under the Agreement, whether Set-Aside or Guaranteed Capacity, and in no event will Developer be denied capacity as a result of SAWS' utilization of such capacity for another tract. Set-Aside capacity shall not survive the expiration of the Agreement.

**G.C.16.00 Utility Master Plan Requirements.**

The Developer will prepare a utility master plan, which details the water and/or wastewater systems for the Tract pursuant to the USR, as amended.

**G.C.17.00 Phased Utility Master Plans.**

If the Developer's water and/or wastewater systems are to be installed in phases or units, the Developer shall submit overall utility master plans to SAWS for review and approval. The overall utility master plan(s) shall be submitted before the first construction phase is submitted for plat approval. The overall utility master plan(s) shall show the development phases or units including the sequence and a timetable for build-out. The Developer shall also provide SAWS with a digital version of the proposed recorded plat, as submitted for plat recordation in a format acceptable to SAWS, for each phase or unit of the development project.

**G.C.18.00 Conformance of Plans to Utility Master Plan.**

All water and wastewater system facilities to serve the Tract shall be designed and constructed in conformance with the approved utility master plan. Changes in the water and wastewater system design shall be resubmitted to SAWS for written approval.

**G.C.19.00 Timing Requirements for Submission of Plans.**

Developer shall have three (3) years from the Effective Date of the Agreement to complete and submit the required utility master plan and to start construction of the Off-Site and On-Site utility infrastructure described in the Special Conditions. Developer agrees that the Agreement for the provision of Services shall automatically expire if Developer

has not submitted a utility master plan and started construction of required Off-Site and On-Site utility infrastructure within three (3) years of the Effective Date of the Agreement, and a new request for the Services must be submitted to SAWS, which SAWS will grant based on then existing policies and regulations. In the event Developer meets the above-mentioned requirements within the three (3) year period provided, the Agreement shall remain in effect for seven (7) years from the Effective Date. If Developer submits a revised Utility Master Plan in accordance with the USR prior to the expiration of the seven (7) year period, the Agreement for the provision of Services may be extended to a maximum term of fifteen (15) years from the Effective Date.

**G.C. 20.00 EDU Transfers.**

The transfer of EDU capacity outside the original boundaries of this Utility Service Agreement will not be allowed. The San Antonio Water System considers this Agreement to run with the land; however, EDU capacity transfers to subdivided tracts within the Tract of this Agreement are the responsibility of the Developer and approval of such transfers is not required by the San Antonio Water System. The Developer shall maintain an accounting of the EDU capacity that is used by the Developer and/or transferred after the effective date of this Agreement to portions of the Tract. If the Developer sells a portion of the Tract and transfers part of the EDU capacity contained in this Agreement, then that EDU capacity transfer must be included in the deed, bill of sale or instrument conveying the land and the Developer must require the buyer of the land who receives the allocated EDUs to record the instrument effectuating the transfer. Developer may file a Master Development Plan or an EDU Plan, prepared by an engineer, that shows specific EDU capacity allocations within the Tract and shall ensure that the Master Development Plan or EDU Plan is attached to this Agreement and properly recorded. SAWS will recognize the capacity allocations within the Master Development Plan or EDU Plan so long as those allocations are within the parameters of this Agreement. For properties that have areas of unplanned use, the demand will be calculated at four (4) EDUs per acre unless the engineering report specifies otherwise or there is not enough EDU capacity remaining for the Tract to allocate four (4) EDUs per acre.

In no event will the System be responsible to 3<sup>rd</sup> parties for providing water supply or wastewater discharge capacity beyond the total EDU capacity identified in this Agreement for the Tract. Developer expressly disclaims, releases and holds harmless SAWS from any liability, damages, costs or fees, and agrees to indemnify SAWS for any liability, including, costs and attorney's fees, associated with any dispute related to the transfer of all or a portion of EDU capacity approved for the Tract in this Utility Services Agreement.

**G.C. 21.00 Camp Bullis Awareness Zone.**

In the event that the Tract is located within, or partially within, the Camp Bullis Awareness Zone, the Developer acknowledges that certain lighting regulations may apply within at least a 3-mile radius of Camp Bullis, commonly referred to as down-lighting or dark sky lighting, and Developer will comply with those regulations. Developer agrees to comply with any local, state or federal law, rule or regulation related to the protection of the environment or endangered species, including but not limited to, any site assessments or surveys and notice to the United States Fish & Wildlife when required by law, rule or regulation. Developer acknowledges that any required assessment, survey or notice shall be current or updated as may be required by law, rule or regulation.

**G.C. 22.00 Written Project Information.**

The project associated with this Utility Service Agreement is described in the forms submitted by the applicant including but not limited to 1) a cover sheet clearly stating "USA Request" and the project name; 2) the Engineering Report; and 3) a legal description, metes and bounds description, or Master Development Plan (MDP), subdivision plat, or similar document of the Tract.

**SPECIAL CONDITIONS OF THE UTILITY SERVICE AGREEMENT**

**WATER SERVICE**

**S.C.1.00 Tract Location and Ultimate Demand.**

Specht Tract, a 173.3-acre tract outside the City of San Antonio limits, is located northeast of the intersection of Blanco Rd and Specht Rd, as shown in Attachment VI (the "Tract"). The Tract is located over the Edwards Aquifer Recharge or Contributing Zone and is located within the 5-mile Awareness Zone of Camp Bullis. The proposed Tract is located inside SAWS' water CCN, inside SAWS' wastewater CCN and does require SAWS' financial participation in the development of infrastructure through oversizing or impact fee credits, therefore, Board Action is required.

The ultimate demand from the proposed development, on SAWS' water infrastructure, shall not exceed 430 equivalent dwelling units (EDUs) of water supply.

**S.C.2.00 Infrastructure Requirements.**

Water Supply to the Tract will be from Pressure Zone (PZ) 1400. The flow capacity of a 12-inch main is required to supply water to the 173.3-acre Tract, in conformance with SAWS' Utility Service Regulations (USR).

The Developer shall construct a 12-inch (oversized to 16-inch) approach main from the existing 12-inch main (Job No. 13-5201) on W Borgfeld Dr, along W Borgfeld Dr, Old Blanco Rd, Blanco Rd, to the Tract and along Specht Rd.

The Developer will be required to install a pressure reducing valve (PRV) on the proposed 12-inch (oversized to 16-inch) approach main, per SAWS' USR, as shown in Attachment III. The final location of the PRV is to be determined by SAWS.

The Developer shall then construct a series of looped 8-inch and 12-inch mains throughout the Tract with no less than two (2) connections to the proposed 12-inch (oversized to 16-inch) border main along Specht Rd.

The Developer shall then connect services to the proposed series of looped 8-inch and 12-inch mains throughout the Tract.

**S.C. 3.00 SAWS Master Plan and Oversizing Requirements.**

SAWS' Water Infrastructure Plan and the anticipated growth in this area requires a 16-inch main between the existing 12-inch main (Job No. 13-5201) on W Borgfeld Dr and the southern boundary of the Tract. In conformance with SAWS' USR, SAWS shall require that approximately 9,700 feet of required 12-inch main, from the existing 12-inch main on W Borgfeld Dr to the southern boundary of the Tract, be oversized to a 16-inch main. The total estimated cost of the oversized main is \$2,017,600.00. The Developer's estimated share is 56.25%, a cost of \$1,134,900.00; and SAWS' estimated share is 43.75%, a cost of \$882,700.00.

SAWS' reimbursement to the Developer for the oversized water main construction costs will be calculated based on the incremental cost of the oversized construction. The Developer's cost sharing amount will be the greater of either (a) \$60.00 per linear foot or (b) the Developer's pro-rated share of the cost of the oversized main, excluding costs related to service connections. The Developer's pro-rated share will be based on the ratio of the pipe area using the nominal diameter of the required standard size main to the pipe area using the nominal diameter of the oversized main installed. This regulation is based on the current USR but is subject to change on future revisions.

**S.C.4.00 Impact Fee Credit Eligibility.**

The 16-inch main is an impact fee eligible Capital Improvement Project in the current impact fees study; hence, the Developer is eligible for impact fee credits for their share of the cost for the 16-inch main.

**S.C.5.00 Engineering Study Report and/or Pro-Rata Refund Eligibility.**

The engineering study report "Specht Tract, Utility Service Agreement Engineering Report", by Cude Engineers, dated December 2019 is included as Attachment VI.

**S.C.6.00 Developer On-Site and/or Off-Site Requirements.**

The Developer shall acquire any right-of-way or easements, and install all On-Site and Off-Site utility infrastructure required to serve the Tract in accordance with SAWS' USR, solely at the Developer's cost, unless otherwise stated in S.C.3.00 or S.C.4.00. Other On-Site requirements within the Tract will be determined at such time as the engineer submits an overall Utility Master Plan, and any subsequent revisions, for the Tract.

**S.C.7.00 Requirement to Install Approved Pressure Regulators and/or Booster Pumps.**

The entire Tract is below ground elevation of 1215 feet where the static pressure will theoretically exceed 80 psi. Any service connections within the Tract, at elevations lower than this ground elevation, shall require the installation of a Pressure Reducing Valve (PRV), on the customer(s) side of the meter, rated for a maximum working pressure of no less than 300 psi, prior to a SAWS meter being installed. Installation shall be in conformance with the current Plumbing Code with Local Amendments adopted by the City of San Antonio.

**S.C.8.00 Time for Water Impact Fee Assessment and Payment.**

Water Impact Fees will be assessed at the rates in effect at the time of plat recordation or the latest date allowed by law. Impact fees will be collected at either the time of plat recordation or connection to the SAWS' water system, at the discretion of the Developer.

**S.C.9.00 Water Impact Fee Estimates Based Upon Current Charges.**

Following is an estimate of impact fees for the provision of Services contemplated under the Agreement, which are based on current impact fee rates. This estimate shall not constitute an assessment of impact fees and impact fee rates are subject to change by the San Antonio City Council.

<b>Type of Impact Fee</b>	<b>EDUs</b>	<b>\$/EDUs</b>	<b>Current Total</b>
Flow Development	430	\$1,188	\$510,840
System Development Middle	430	\$1,014	\$436,020
Water Supply	430	\$2,706	\$1,163,580
<b>Total</b>			<b>\$2,110,440</b>

**S.C.10.00 Pro-Rata Charge Requirement.**

Developer shall be required to pay a Pro-Rata Charge pursuant to the USR, as amended, prior to connection to the SAWS water system if Developer is tying into a main that is subject to a pro-rata refund.

**SPECIAL CONDITIONS OF THE UTILITY SERVICE AGREEMENT**

**WASTEWATER SERVICE**

**S.C.1.00 Tract Location and Ultimate Demand.**

Specht Tract, a 173.3-acre tract outside the City of San Antonio limits, is located northeast of the intersection of Blanco Rd and Specht Rd, as shown in Attachment VI (the "Tract") and lies within SAWS' Upper Collection and Treatment Area (UCTA). The Tract is located over the Edwards Aquifer Recharge or Contributing Zone and is located within the 5-mile Awareness Zone of Camp Bullis. The proposed Tract is located inside SAWS' water CCN, inside SAWS' wastewater CCN and does require SAWS' financial participation in the development of infrastructure through oversizing or impact fee credits, therefore, Board Action is required.

The ultimate demand from the proposed development, on SAWS' wastewater infrastructure, shall not exceed 430 equivalent dwelling units (EDUs) of wastewater discharge.

**S.C.2.00 Infrastructure Requirements.**

The Tract is situated within SAWS' Upper Collection and Treatment Area (UCTA) and lies within the Indian Creek-Cibolo Creek Watershed. The capacity of an 8-inch gravity main at 0.40 percent minimum slope is required to provide wastewater service to the Tract, in conformance with SAWS' USR.

Phase 1:

Downstream Requirements

In order to serve demands for this Tract, the Developer will be required to make improvements to the existing Sterling Ridge Lift Station to accommodate the additional flow from this Tract, in conformance with SAWS' USR.

Upstream Requirements

The Developer may construct a lift station/force main system to serve the ultimate demand of 430 EDUs of total capacity, in accordance with SAWS' USR.

Upon SAWS acceptance of Job No. 17-1583 and completion of Phase I requirements, the Developer may connect a maximum of 250 EDUs of total capacity to the proposed lift station/force main system. In order to obtain any additional capacity beyond 250 EDUs, the Developer will be required to construct Phase II requirements.

Phase 2:

The Developer shall make improvements to the existing infrastructure downstream of the Sterling Ridge Lift Station. The improvements will require the replacement of approximately 400 LF of existing 8-inch gravity sewer main with an upsized 12-inch gravity sewer main, as shown in Attachment III.

After the construction of the aforementioned infrastructure, the Developer will be allowed to connect the remaining 180 EDUs total of capacity to the proposed lift station/force main system.

**S.C.3.00 SAWS Master Plan and Oversizing Requirements.**

N/A

**S.C.4.00 Impact Fee Credit Eligibility.**

N/A

**S.C.5.00 Engineering Study Report and/or Pro-Rata Refund Eligibility.**

The engineering study report "Specht Tract, Utility Service Agreement Engineering Report", by Cude Engineers, dated December 2019 is included as Attachment VI.

**S.C.6.00 Developer On-Site and/or Off-Site Requirements.**

The Developer will also be required to acquire any right-of-way and easements, install all On-Site and Off-Site utility infrastructure, and upgrade existing lift stations necessary to serve the Tract in accordance with SAWS' USR, solely at the Developer's cost, unless stated otherwise in S.C.3.00 or S.C.4.00. Other On-Site utility infrastructure requirements within the Tract will be determined at such time as the engineer submits an overall Utility Master Plan, and any subsequent revisions, for the Tract.

**S.C.7.00 Lift Stations and Force Mains.**

Lift stations and force mains are only allowed by prior written supplemental agreement with SAWS. Applicable fees, as set out in the supplemental agreement, must be paid in full prior to service connection. Whenever a lift station is proposed, a Present Value analysis of the lift station vs. gravity solutions, shall be included in the Engineering Report/Study in conformance with the requirements of SAWS' USR.

**S.C.8.00 Time for Wastewater Impact Fee Assessment and Payment.**

Wastewater Impact Fees will be assessed at the rates in effect at the time of plat recordation or the latest date allowed by law. Wastewater Impact Fees will be collected at either the time of plat recordation or connection to the SAWS wastewater system, at the discretion of the Developer.

**S.C.9.00 Wastewater Impact Fee Estimates Based Upon Current Charges.**

Following is an estimate of impact fees for the provision of Services contemplated under the Agreement, which are based on impact fee rates in effect as of the Effective Date of the Agreement. This estimate shall not constitute an assessment of impact fees and impact fee rates are subject to change by action of the San Antonio City Council as permitted by law.

Type of Impact Fee	EDUs	\$/EDUs	Current Total
Wastewater Collection Upper	430	\$2,800	\$1,204,000
Wastewater Treatment Dos Rios/Leon Creek	430	\$651	\$279,930
Total			\$1,483,930

**S.C.10.00 Pro-Rata Payment Fee Requirement.**

Developer shall be required to pay a pro-rata fee pursuant to the USR, as amended, prior to connection to the wastewater system, if Developer is tapping into a main that is subject to a pro-rata refund.



Attachment III:  
USA-23714  
"Specht Tract"  
Proposed Water Infrastructure Map  
173.3 Acres

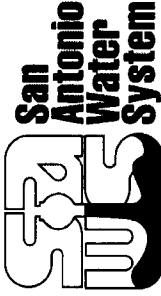

**Legend**

- Parcels Update
- USA Tract
- Existing Water Main
- Proposed PRV
- Proposed 12-inch (Oversized to 16-inch) Water Main

**Project Location**



**DISCLAIMER**  
The information on this map was prepared and is based on data provided to the City of San Antonio by the San Antonio Water System (SAWS). The information on this map is not intended to be used for any purpose other than the specific purpose for which it was prepared. The City of San Antonio and SAWS do not warrant the accuracy or completeness of the information on this map. The City of San Antonio and SAWS are not responsible for any errors or omissions on this map. The City of San Antonio and SAWS are not responsible for any damages, including consequential damages, arising from the use of this map. The City of San Antonio and SAWS are not responsible for any actions taken based on the information on this map. This disclaimer is intended to be read in conjunction with the other documents in this project file.

Tract is Located:  
-Over The Edwards Aquifer Recharge Zone  
-Within the 5-Mile Camp Bullis Awareness Zone  
-Within the 5-Mile JBSA Buffer Zone  
-Within the APZ

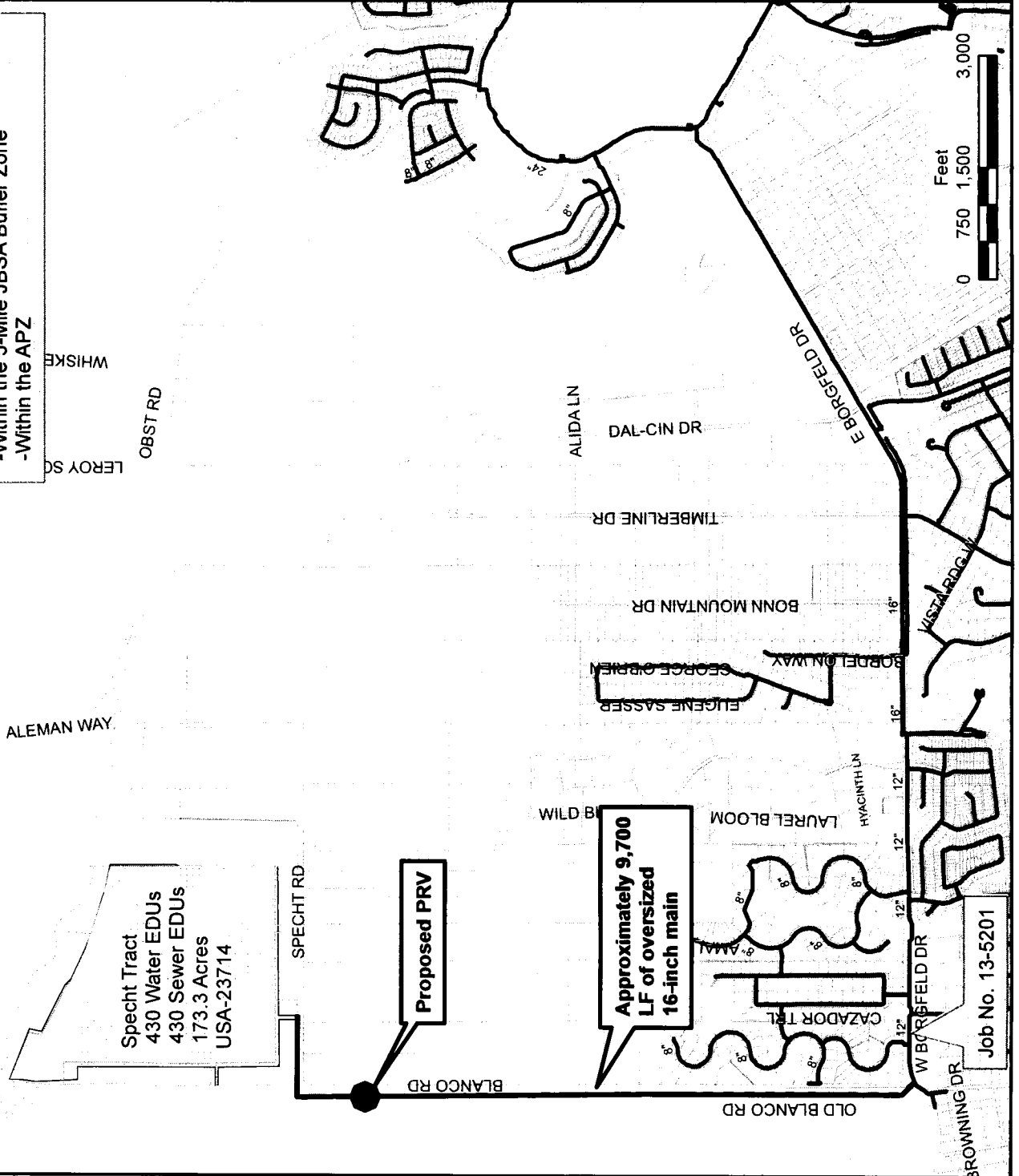

Attachment III:  
USA-23714  
"Specht Tract"  
Proposed Sewer Infrastructure Map  
173.3 Acres



**Legend**

Parcels Update  
USA Tract  
Existing Sewer Main  
Future Force Main  
Existing Lift Station  
Proposed Lift Station (Phase 1)  
Proposed Force Main (Phase 1)  
Proposed Upsized 12" Sewer Main (Phase 2)

**Project Location**

**DISCLAIMER:** THIS INFORMATION IS PROVIDED FOR YOUR INFORMATION ONLY. THE INFORMATION MAY BE USED FOR ANY PURPOSE, BUT THE USER ASSUMES ALL LIABILITY FOR THE ACCURACY OF THE INFORMATION. THE USER SHALL NOT BE HELD RESPONSIBLE FOR ANY ERRORS, OMISSIONS, OR INACCURACIES IN THE INFORMATION. THE USER SHALL BE RESPONSIBLE FOR OBTAINING ALL NECESSARY PERMITS AND APPROVALS FROM ALL APPLICABLE AGENCIES. THE USER SHALL BE RESPONSIBLE FOR OBTAINING ALL NECESSARY PERMITS AND APPROVALS FROM ALL APPLICABLE AGENCIES. THE USER SHALL BE RESPONSIBLE FOR OBTAINING ALL NECESSARY PERMITS AND APPROVALS FROM ALL APPLICABLE AGENCIES.

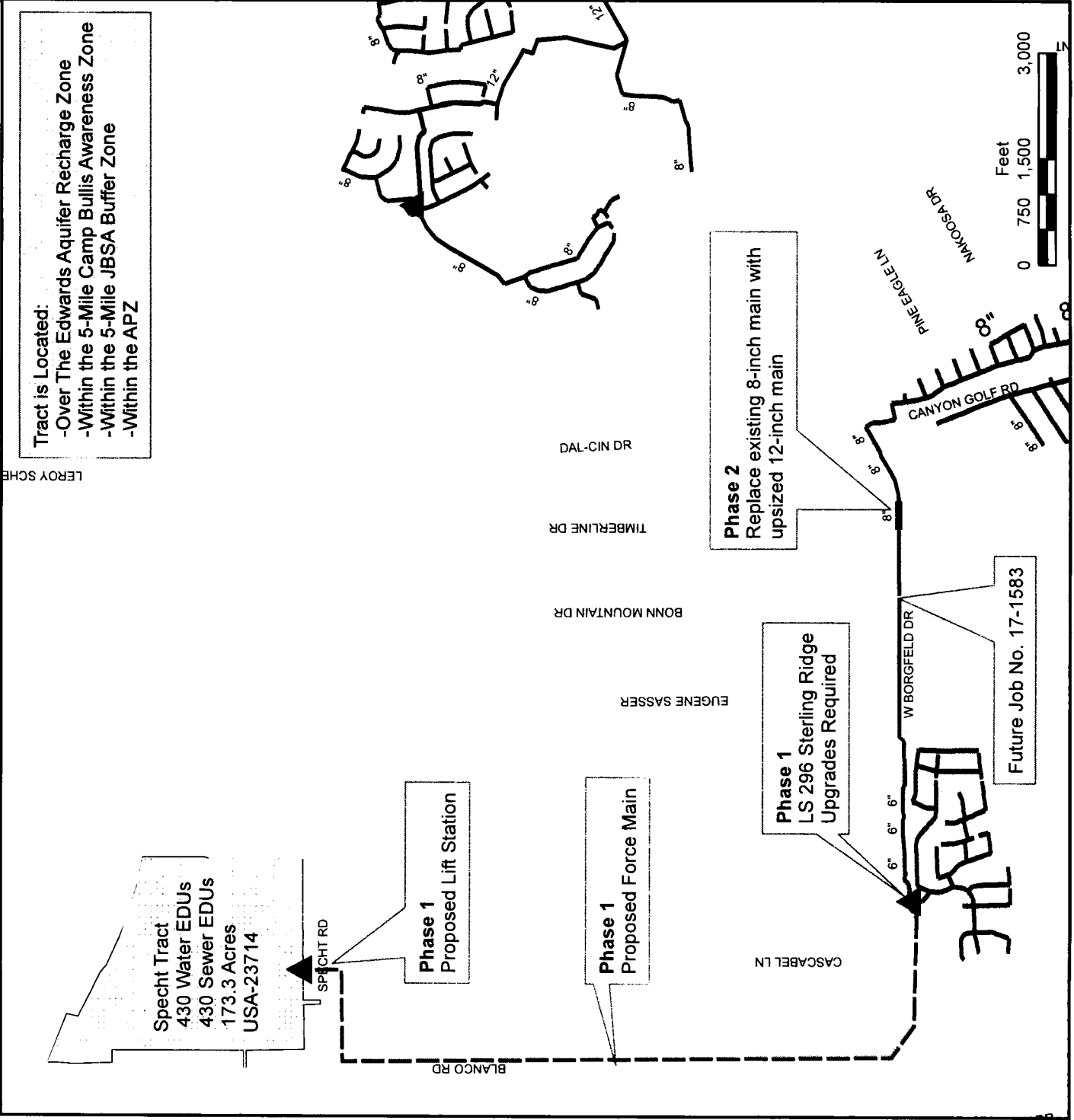

**LIFT STATION AND FORCE MAIN SUPPLEMENTAL AGREEMENT**

Specht Tract

It is expressly recognized that the tract may be situated in more than one drainage sub basin and that the Developer may seek approval to install on-site and/or off-site lift station/force main systems to serve the tract subject to prior approval by the Director of Development. Should Developer so elect and the Director of Development so concur, all systems shall be designed and constructed at Developer's total expense and at no cost to SAWS. The Developer may have the option of constructing gravity off-site lines so as to develop preferred gravity flows and eliminate the necessity for the lift station/force main systems, subject to prior approval by SAWS of all design, plans and construction of such systems. The Developer must prepare a present value analysis of the cost of constructing gravity mains compared to the cost of constructing and operating the lift station/force main system. The analysis must demonstrate that the cost of the gravity main option, including off-site easements, is more than three (3) times the cost of the lift station/force main system designed according to SAWS' Lift Station Guidelines including the applicable Lift Station Maintenance Fee in effect.

In the event that prerequisite approvals to install on-site and/or off-site lift station/force main system are secured by Developer, the Developer shall establish a fund to cover the annual maintenance fees for a 10 year period, as approved SAWS's Legal Department and the Vice President of Finance for each lift station/force main system constructed to serve any property within this tract. The creation and approval of said fund shall be a condition precedent for approval and release for recordation by SAWS of the plat of the properties for which the lift station/force main system shall be constructed to serve. This fund shall guarantee the entire payment of the current fee to SAWS for each lift station/force main system constructed to serve property within said tract for a period of ten (10) years following the post-construction acceptance date of each force main and lift station system. The Developer is required to pay a one-time life station maintenance fee of \$209,642 per lift station.

*This fee may be adjusted in the event that the System formally adopts a new lift station/force main system operation and maintenance fee schedule, in accordance with the current City of San Antonio's Unified Development Code Section 34-236.*

**ACCEPTED AND AGREED TO IN ALL THINGS:**

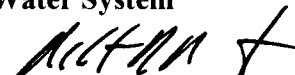
**San Antonio Water System**  
Signature:   
Print Name: Robert R. Puente  
Title: President/Chief Executive Officer  
Date: 9-15-21

**Developer**  
Signature:   
Print Name: Brian A. H.  
Title: Vice President of Land  
Date: 9/15/21

**RESOLUTION NO. 2020-133**

**OF THE SAN ANTONIO WATER SYSTEM BOARD OF TRUSTEES APPROVING UTILITY SERVICE AGREEMENTS TO PROVIDE WATER AND/OR WASTEWATER SERVICES TO THE SPECIFIED TRACTS OF LAND REQUIRING THE SAN ANTONIO WATER SYSTEM'S FINANCIAL PARTICIPATION IN THE DEVELOPMENT OF INFRASTRUCTURE THROUGH OVERSIZING AND/OR IMPACT FEE CREDITS AND/OR ARE LOCATED OUTSIDE THE SAN ANTONIO WATER SYSTEM'S WATER AND/OR WASTEWATER CERTIFICATE OF CONVENIENCE AND NECESSITY (CCN), SUBJECT TO THE EXPIRATION OF SUCH AGREEMENT IF NOT EXERCISED IN THIRTY-SIX MONTHS; FINDING THE RESOLUTION TO HAVE BEEN CONSIDERED PURSUANT TO THE LAWS GOVERNING OPEN MEETINGS; PROVIDING A SEVERABILITY CLAUSE; AND ESTABLISHING AN EFFECTIVE DATE**

**WHEREAS, the Developer Customer, specified in the table below, has requested the San Antonio Water System (the "System") to provide water and/or wastewater service(s), and has satisfied the requirements of the Board's Regulations for Developer Customer Applicant; and**

No.	Tract Name	Developer	Acres	W EDUs	WW EDUs	CoSA / CoSA ETJ / Outside	EARZ / CZ	JBSA	Board Reason	W CCN	WW CCN
1	Stevens Ranch Tract	Potranco 2013 Land, Ltd.	1,950	7,090	7,725	CoSA ETJ	OUTSIDE	N	CCN & IFC & OVR	Partially OUTSIDE	INSIDE
2	Specht Tract	Meritage Homes of Texas, LLC	173.30	430	430	CoSA ETJ	INSIDE	Y	IFC & OVR	INSIDE	INSIDE
3	Somerset Tract	Lennar Homes	68.75	362	362	CoSA	OUTSIDE	Y	OVR	INSIDE	INSIDE
4	Tuscan Oaks Tract	Lee Hagan Partnership, Ltd.	21.98	220	132	CoSA & CoSA ETJ	INSIDE	Y	OVR	INSIDE	INSIDE
5	Schuchart Tract	Chris Schuchart	1,198.90	4,700	4,700	Partially OUTSIDE	OUTSIDE	N	CCN & IFC & OVR	Partially OUTSIDE	Partially OUTSIDE
<b>Total</b>			<b>3,412.93</b>	<b>12,802</b>	<b>13,349</b>						

**WHEREAS, the Developer Customer's provisions to acquire water and/or wastewater services within the System's jurisdiction is generally illustrated in the attached Project Site Maps; and**

**WHEREAS**, the Developer Customer is obligated to pay the prescribed fees and to comply with other applicable requirements as set forth in the Regulations for Water and/or Wastewater Service; and

**WHEREAS**, the San Antonio Water System Board of Trustees desires (i) to approve the Utility Service Agreements and to provide water and/or wastewater services to tracts of land requiring the System's financial participation in the development of infrastructure through oversizing and/or impact fee credits and/or are located outside the System's water and/or wastewater Certificate of Convenience and Necessity, and (ii) to provide that the Utility Service Agreement will be honored for a period of thirty-six months, and that if not exercised during this period, the Utility Service Agreement will expire; now, therefore:

**BE IT RESOLVED BY THE SAN ANTONIO WATER SYSTEM BOARD OF TRUSTEES:**

1. That the System hereby approves the Utility Service Agreements and agrees to provide water and/or wastewater services to tracts of land requiring the System's financial participation in the development of infrastructure through oversizing and/or impact fee credits and/or are located outside the System's water and/or wastewater Certificate of Convenience and Necessity as generally illustrated in the attached Project Site Maps hereto, on a Developer Customer basis as provided for in the Board's Regulations, applicable amendments to the Regulations, and any other applicable federal, state or local regulations.
2. That the Utility Service Agreement shall be honored for a period of thirty-six months, and if not exercised during this thirty-six-month period, the Utility Service Agreement will expire.
3. It is officially found, determined and declared that the meeting at which this resolution is adopted was open to the public, and that public notice of the time, place and subject matter of the public business to be conducted at such meeting, including this resolution, was given to all as required by the Texas Codes Annotated, as amended, Title 5, Chapter 551, Government Code.
4. If any part, section, paragraph, sentence, phrase or word of this resolution is for any reason held to be unconstitutional, illegal, inoperative or invalid, or if any exception to or limitation upon any general provision herein contained is held to be unconstitutional, illegal, invalid or ineffective, the remainder of this resolution shall nevertheless stand effective and valid as if it had been enacted without the portion held to be unconstitutional, illegal, invalid or ineffective.
5. This resolution becomes effective immediately upon its passage

PASSED AND APPROVED this 9<sup>th</sup> day of June, 2020.

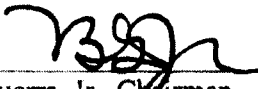
  
\_\_\_\_\_  
Berto Guerra, Jr., Chairman

ATTEST:

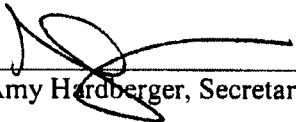
  
\_\_\_\_\_  
Amy Hardberger, Secretary

Attachments:  
Location Map  
Project Site Maps



\*VG-6-2021-20210263974\*

**File Information**

**FILED IN THE OFFICIAL PUBLIC RECORDS OF BEXAR COUNTY  
LUCY ADAME-CLARK, BEXAR COUNTY CLERK**

**Document Number:** 20210263974  
**Recorded Date:** September 22, 2021  
**Recorded Time:** 9:34 AM  
**Total Pages:** 22  
**Total Fees:** \$106.00

**\*\* THIS PAGE IS PART OF THE DOCUMENT \*\***

**\*\* Do Not Remove \*\***

Any provision herein which restricts the sale or use of the described real property because of race is invalid and unenforceable under Federal law

STATE OF TEXAS, COUNTY OF BEXAR

I hereby Certify that this instrument was FILED in File Number Sequence on this date and at the time stamped hereon by me and was duly RECORDED in the Official Public Record of Bexar County, Texas on:  
9/22/2021 9:34 AM



*Lucy Adame-Clark*  
Lucy Adame-Clark  
Bexar County Clerk

Estancia Ranch, Unit 3  
Organized Sewage Collection System Plan



**ENGINEERING DESIGN REPORT**  
**ATTACHMENT B – GENERAL UTILITIES WASTEWATER NOTES**



**Texas Commission on Environmental Quality  
Organized Sewage Collection System  
General Construction Notes**

**Edwards Aquifer Protection Program Construction Notes – Legal Disclaimer**

*The following/listed “construction notes” are intended to be advisory in nature only and do not constitute an approval or conditional approval by the Executive Director, nor do they constitute a comprehensive listing of rules or conditions to be followed during construction. Further actions may be required to achieve compliance with TCEQ regulations found in Title 30, Texas Administrative Code, Chapters 213 and 217, as well as local ordinances and regulations providing for the protection of water quality. Additionally, nothing contained in the following/listed “construction notes” restricts the powers of the Executive Director, the commission or any other governmental entity to prevent, correct, or curtail activities that result or may result in pollution of the Edwards Aquifer or hydrologically connected surface waters. The holder of any Edwards Aquifer Protection Plan containing “construction notes” is still responsible for compliance with Title 30, Texas Administrative Code, Chapters 213 or any other applicable TCEQ regulation, as well as all conditions of an Edwards Aquifer Protection Plan through all phases of plan implementation. Failure to comply with any condition of the Executive Director’s approval, whether or not in contradiction of any “construction notes,” is a violation of TCEQ regulations and any violation is subject to administrative rules, orders, and penalties as provided under Title 30, Texas Administrative Code § 213.10 (relating to Enforcement). Such violations may also be subject to civil penalties and injunction. The following/listed “construction notes” in no way represent an approved exception by the Executive Director to any part of Title 30 Texas Administrative Code, Chapters 213 and 217, or any other TCEQ applicable regulation.*

1. This Organized Sewage Collection System (SCS) must be constructed in accordance with 30 Texas Administrative Code (TAC) §213.5(c), the Texas Commission on Environmental Quality’s (TCEQ) Edwards Aquifer Rules and any local government standard specifications.
2. All contractors conducting regulated activities associated with this proposed regulated project must be provided with copies of the SCS plan and the TCEQ letter indicating the specific conditions of its approval. During the course of these regulated activities, the contractors must be required to keep on-site copies of the plan and the approval letter.
3. A written notice of construction must be submitted to the presiding TCEQ regional office at least 48 hours prior to the start of any regulated activities. This notice must include:
  - the name of the approved project;
  - the activity start date; and
  - the contact information of the prime contractor.
4. Any modification to the activities described in the referenced SCS application following the date of approval may require the submittal of an SCS application to modify this approval, including the payment of appropriate fees and all information necessary for its review and approval.
5. Prior to beginning any construction activity, all temporary erosion and sedimentation (E&S) control measures must be properly installed and maintained in accordance with the manufacturers specifications. These controls must remain in place until the disturbed areas have been permanently stabilized.
6. If any sensitive features are discovered during the wastewater line trenching activities, all regulated activities near the sensitive feature must be suspended immediately. The applicant must immediately notify the appropriate regional office of the TCEQ of the feature discovered. A geologist’s assessment of the location and extent of the feature discovered must be reported to that regional office in writing and the applicant must submit a plan for ensuring the structural integrity of the sewer line or for modifying the proposed collection system alignment around the feature. The regulated activities near the sensitive feature may not proceed until the

executive director has reviewed and approved the methods proposed to protect the sensitive feature and the Edwards Aquifer from any potentially adverse impacts to water quality while maintaining the structural integrity of the line.

7. Sewer lines located within or crossing the 5-year floodplain of a drainage way will be protected from inundation and stream velocities which could cause erosion and scouring of backfill. The trench must be capped with concrete to prevent scouring of backfill, or the sewer lines must be encased in concrete. All concrete shall have a minimum thickness of 6 inches.
8. Blasting procedures for protection of existing sewer lines and other utilities will be in accordance with the National Fire Protection Association criteria. Sand is not allowed as bedding or backfill in trenches that have been blasted. If any existing sewer lines are damaged, the lines must be repaired and retested.
9. All manholes constructed or rehabilitated on this project must have watertight size on size resilient connectors allowing for differential settlement. If manholes are constructed within the 100-year floodplain, the cover must have a gasket and be bolted to the ring. Where gasketed manhole covers are required for more than three manholes in sequence or for more than 1500 feet, alternate means of venting will be provided. Bricks are not an acceptable construction material for any portion of the manhole.

The diameter of the manholes must be a minimum of four feet and the manhole for entry must have a minimum clear opening diameter of 30 inches. These dimensions and other details showing compliance with the commission's rules concerning manholes and sewer line/manhole inverts described in 30 TAC §217.55 are included on Plan Sheet C32 of C32.

It is suggested that entrance into manholes in excess of four feet deep be accomplished by means of a portable ladder. The inclusion of steps in a manhole is prohibited.

10. Where water lines and new sewer line are installed with a separation distance closer than nine feet (i.e., water lines crossing wastewater lines, water lines paralleling wastewater lines, or water lines next to manholes) the installation must meet the requirements of 30 TAC §217.53(d) (Pipe Design) and 30 TAC §290.44(e) (Water Distribution).
11. Where sewers lines deviate from straight alignment and uniform grade all curvature of sewer pipe must be achieved by the following procedure which is recommended by the pipe manufacturer: N/A.

If pipe flexure is proposed, the following method of preventing deflection of the joint must be used: N/A.

Specific care must be taken to ensure that the joint is placed in the center of the trench and properly bedded in accordance with 30 TAC §217.54.

12. New sewage collection system lines must be constructed with stub outs for the connection of anticipated extensions. The location of such stub outs must be marked on the ground such that their location can be easily determined at the time of connection of the extensions. Such stub outs must be manufactured wyes or tees that are compatible in size and material with both the sewer line and the extension. At the time of original construction, new stub-outs must be constructed sufficiently to extend beyond the end of the street pavement. All stub-outs must be sealed with a manufactured cap to prevent leakage. Extensions that were not anticipated at the time of original construction or that are to be connected to an existing sewer line not furnished with stub outs must be connected using a manufactured saddle and in

accordance with accepted plumbing techniques.

If no stub-out is present an alternate method of joining laterals is shown in the detail on Plan Sheet C32 of C32. (For potential future laterals).

The private service lateral stub-outs must be installed as shown on the plan and profile sheets on Plan Sheet C27 to C31 and marked after backfilling as shown in the detail on Plan Sheet C32 of C32.

13. Trenching, bedding and backfill must conform with 30 TAC §217.54. The bedding and backfill for flexible pipe must comply with the standards of ASTM D-2321, Classes IA, IB, II or III. Rigid pipe bedding must comply with the requirements of ASTM C 12 (ANSI A 106.2) classes A, B or C.
14. Sewer lines must be tested from manhole to manhole. When a new sewer line is connected to an existing stub or clean-out, it must be tested from existing manhole to new manhole. If a stub or clean-out is used at the end of the proposed sewer line, no private service attachments may be connected between the last manhole and the cleanout unless it can be certified as conforming with the provisions of 30 TAC §213.5(c)(3)(E).
15. All sewer lines must be tested in accordance with 30 TAC §217.57. The engineer must retain copies of all test results which must be made available to the executive director upon request. The engineer must certify in writing that all wastewater lines have passed all required testing to the appropriate regional office within 30 days of test completion and prior to use of the new collection system. Testing method will be:
  - (a) For a collection system pipe that will transport wastewater by gravity flow, the design must specify an infiltration and exfiltration test or a low-pressure air test. A test must conform to the following requirements:
    - (1) *Low Pressure Air Test.*
      - (A) A low pressure air test must follow the procedures described in American Society For Testing And Materials (ASTM) C-828, ASTM C-924, or ASTM F-1417 or other procedure approved by the executive director, except as to testing times as required in Table C.3 in subparagraph (C) of this paragraph or Equation C.3 in subparagraph (B)(ii) of this paragraph.
      - (B) For sections of collection system pipe less than 36 inch average inside diameter, the following procedure must apply, unless a pipe is to be tested as required by paragraph (2) of this subsection.
        - (i) A pipe must be pressurized to 3.5 pounds per square inch (psi) greater than the pressure exerted by groundwater above the pipe.
        - (ii) Once the pressure is stabilized, the minimum time allowable for the pressure to drop from 3.5 psi gauge to 2.5 psi gauge is computed from the following equation:

Equation C.3

$$T = \frac{0.085 \times D \times K}{Q}$$

Where:

- T = time for pressure to drop 1.0 pound per square inch gauge in seconds  
K = 0.000419 X D X L, but not less than 1.0

- D = average inside pipe diameter in inches
- L = length of line of same size being tested, in feet
- Q = rate of loss, 0.0015 cubic feet per minute per square foot internal surface

(C) Since a K value of less than 1.0 may not be used, the minimum testing time for each pipe diameter is shown in the following Table C.3:

Pipe Diameter ( <i>inches</i> )	Minimum Time ( <i>seconds</i> )	Maximum Length for Minimum Time ( <i>feet</i> )	Time for Longer Length ( <i>seconds/foot</i> )
6	340	398	0.855
8	454	298	1.520
10	567	239	2.374
12	680	199	3.419
15	850	159	5.342
18	1020	133	7.693
21	1190	114	10.471
24	1360	100	13.676
27	1530	88	17.309
30	1700	80	21.369
33	1870	72	25.856

- (D) An owner may stop a test if no pressure loss has occurred during the first 25% of the calculated testing time.
  - (E) If any pressure loss or leakage has occurred during the first 25% of a testing period, then the test must continue for the entire test duration as outlined above or until failure.
  - (F) Wastewater collection system pipes with a 27 inch or larger average inside diameter may be air tested at each joint instead of following the procedure outlined in this section.
  - (G) A testing procedure for pipe with an inside diameter greater than 33 inches must be approved by the executive director.
- (2) *Infiltration/Exfiltration Test.*
- (A) The total exfiltration, as determined by a hydrostatic head test, must not exceed 50 gallons per inch of diameter per mile of pipe per 24 hours at a minimum test head of 2.0 feet above the crown of a pipe at an upstream manhole.
  - (B) An owner shall use an infiltration test in lieu of an exfiltration test when pipes are installed below the groundwater level.
  - (C) The total exfiltration, as determined by a hydrostatic head test, must not exceed 50 gallons per inch diameter per mile of pipe per 24 hours at a minimum test head of two feet above the crown of a pipe at an upstream manhole, or at least two feet above existing groundwater level, whichever is greater.
  - (D) For construction within a 25-year flood plain, the infiltration or exfiltration must not exceed 10 gallons per inch diameter per mile of pipe per 24 hours at the same minimum test head as in subparagraph (C) of this paragraph.

- (E) If the quantity of infiltration or exfiltration exceeds the maximum quantity specified, an owner shall undertake remedial action in order to reduce the infiltration or exfiltration to an amount within the limits specified. An owner shall retest a pipe following a remediation action.
- (b) If a gravity collection pipe is composed of flexible pipe, deflection testing is also required. The following procedures must be followed:
  - (1) For a collection pipe with inside diameter less than 27 inches, deflection measurement requires a rigid mandrel.
    - (A) *Mandrel Sizing.*
      - (i) A rigid mandrel must have an outside diameter (OD) not less than 95% of the base inside diameter (ID) or average ID of a pipe, as specified in the appropriate standard by the ASTMs, American Water Works Association, UNI-BELL, or American National Standards Institute, or any related appendix.
      - (ii) If a mandrel sizing diameter is not specified in the appropriate standard, the mandrel must have an OD equal to 95% of the ID of a pipe. In this case, the ID of the pipe, for the purpose of determining the OD of the mandrel, must equal be the average outside diameter minus two minimum wall thicknesses for OD controlled pipe and the average inside diameter for ID controlled pipe.
      - (iii) All dimensions must meet the appropriate standard.
    - (B) *Mandrel Design.*
      - (i) A rigid mandrel must be constructed of a metal or a rigid plastic material that can withstand 200 psi without being deformed.
      - (ii) A mandrel must have nine or more odd number of runners or legs.
      - (iii) A barrel section length must equal at least 75% of the inside diameter of a pipe.
      - (iv) Each size mandrel must use a separate proving ring.
    - (C) *Method Options.*
      - (i) An adjustable or flexible mandrel is prohibited.
      - (ii) A test may not use television inspection as a substitute for a deflection test.
      - (iii) If requested, the executive director may approve the use of a deflectometer or a mandrel with removable legs or runners on a case-by-case basis.
  - (2) For a gravity collection system pipe with an inside diameter 27 inches and greater, other test methods may be used to determine vertical deflection.
  - (3) A deflection test method must be accurate to within plus or minus 0.2% deflection.
  - (4) An owner shall not conduct a deflection test until at least 30 days after the final backfill.
  - (5) Gravity collection system pipe deflection must not exceed five percent (5%).
  - (6) If a pipe section fails a deflection test, an owner shall correct the problem and conduct a second test after the final backfill has been in place at least 30 days.

16. All manholes must be tested to meet or exceed the requirements of 30 TAC §217.58.

- (a) All manholes must pass a leakage test.

- (b) An owner shall test each manhole (after assembly and backfilling) for leakage, separate and independent of the collection system pipes, by hydrostatic exfiltration testing, vacuum testing, or other method approved by the executive director.

(1) Hydrostatic Testing.

- (A) The maximum leakage for hydrostatic testing or any alternative test methods is 0.025 gallons per foot diameter per foot of manhole depth per hour.
- (B) To perform a hydrostatic exfiltration test, an owner shall seal all wastewater pipes coming into a manhole with an internal pipe plug, fill the manhole with water, and maintain the test for at least one hour.
- (C) A test for concrete manholes may use a 24-hour wetting period before testing to allow saturation of the concrete.

(2) Vacuum Testing.

- (A) To perform a vacuum test, an owner shall plug all lift holes and exterior joints with a non-shrink grout and plug all pipes entering a manhole.
- (B) No grout must be placed in horizontal joints before testing.
- (C) Stub-outs, manhole boots, and pipe plugs must be secured to prevent movement while a vacuum is drawn.
- (D) An owner shall use a minimum 60 inch/lb torque wrench to tighten the external clamps that secure a test cover to the top of a manhole.
- (E) A test head must be placed at the inside of the top of a cone section, and the seal inflated in accordance with the manufacturer's recommendations.
- (F) There must be a vacuum of 10 inches of mercury inside a manhole to perform a valid test.
- (G) A test does not begin until after the vacuum pump is off.
- (H) A manhole passes the test if after 2.0 minutes and with all valves closed, the vacuum is at least 9.0 inches of mercury.

17. All private service laterals must be inspected and certified in accordance with 30 TAC §213.5(c)(3)(I). After installation of and, prior to covering and connecting a private service lateral to an existing organized sewage collection system, a Texas Licensed Professional Engineer, Texas Registered Sanitarian, or appropriate city inspector must visually inspect the private service lateral and the connection to the sewage collection system, and certify that it is constructed in conformity with the applicable provisions of this section. The owner of the collection system must maintain such certifications for five years and forward copies to the appropriate regional office upon request. Connections may only be made to an approved sewage collection system.

Austin Regional Office 12100 Park 35 Circle, Building A Austin, Texas 78753-1808 Phone (512) 339-2929 Fax (512) 339-3795	San Antonio Regional Office 14250 Judson Road San Antonio, Texas 78233-4480 Phone (210) 490-3096 Fax (210) 545-4329
--	---

**THESE GENERAL CONSTRUCTION NOTES MUST BE INCLUDED ON THE CONSTRUCTION PLANS PROVIDED TO THE CONTRACTOR AND ALL SUBCONTRACTORS.**



**ATTACHMENT B – JUSTIFICATION & CALCULATIONS FOR DEVIATION IN STRAIGHT  
ALIGNMENT WITHOUT MANHOLES**  
NOT APPLICABLE



**ATTACHMENT C – JUSTIFICATION FOR VARIANCE FROM MANHOLE SPACING**  
NOT APPLICABLE





**ATTACHMENT D – EXPLANATION OF SLOPES FOR FLOWS GREATER THAN 10.0 FEET  
PER SECOND**  
NOT APPLICABLE



## ATTACHMENT E – SITE PLAN

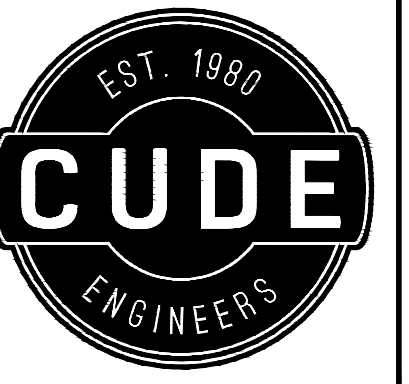

4122 Pond Hill Road, Suite 101  
San Antonio, Texas 78231  
P:(210) 681.2951 F:(210) 523.7112

**ESTANCIA RANCH SUBDIVISION  
UNIT 3**  
SEWAGE COLLECTION SYSTEM  
SITE PLAN

DATE  
09/21/2023  
PROJECT NO.  
03473.010  
DRAWN BY  
CG/TC/D/XV  
CHECKED BY  
XV/AL

NO.	DATE	REVISIONS
1		
2		
3		
4		
5		
6		
7		
8		
9		

STATE OF TEXAS  
  
**ANDREW R. LOWRY**  
 PROFESSIONAL ENGINEER  
 10/30/23  
**CUDE ENGINEERS**  
 TBPE No. 455  
 TBPLS No. 10048500

**C1.00**

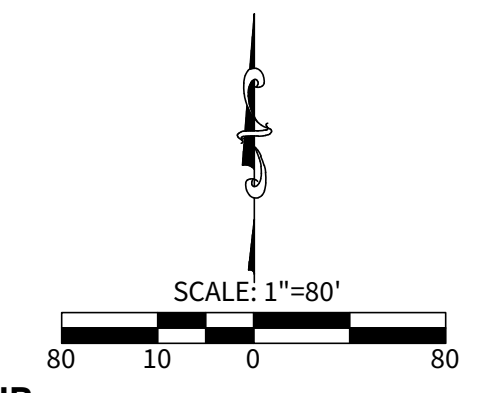

**LEGEND**

OVERALL UNIT BOUNDARY	---
EXISTING 2' CONTOUR	- - - - -
EXISTING 10' CONTOUR	- - - - -
EXISTING WATER LINE	—●—
EXISTING SEWER LINE	—●—
EXISTING MANHOLE	●
PROPOSED WATER LINE	—●—
PROPOSED SEWER MAIN	—●—
PROPOSED MANHOLE	●
50' ENVELOPE	- - - - -
SEWER LATERAL & WATER MAIN CROSSING	○

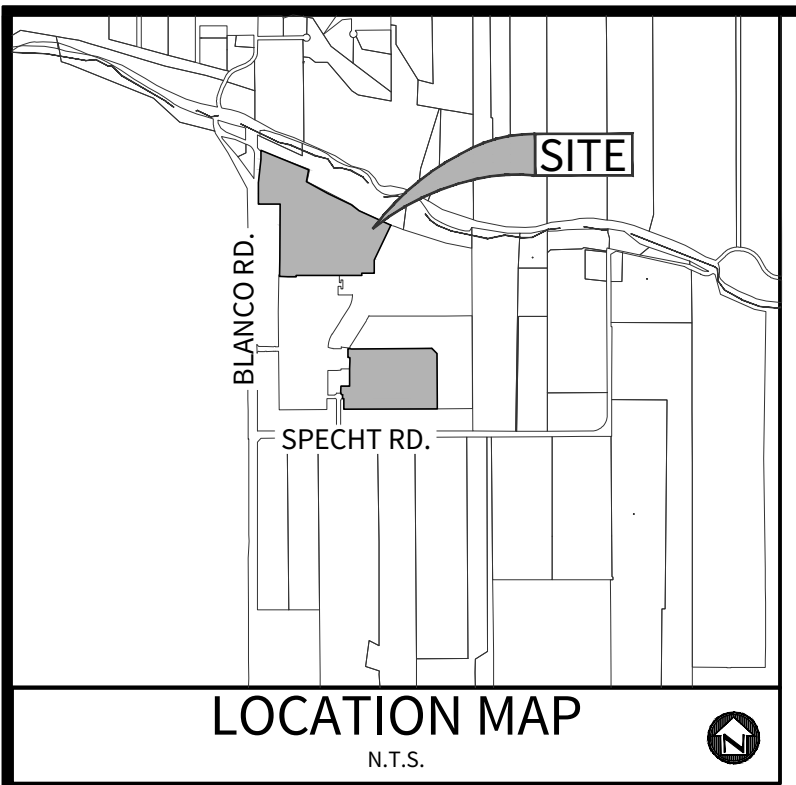

**OWNER/DEVELOPER:**  
 MERITAGE HOMES OF TEXAS, L.L.C.  
 CONTACT PERSON: TONDA ALEXANDER  
 2722 WEST BITTERS ROAD, SUITE 200  
 SAN ANTONIO, TX 78231  
 TEL: (210) 298-4294

**CIVIL ENGINEER:**  
 M.W. CUDE ENGINEERS, L.L.C.  
 CONTACT PERSON: ANDREW R. LOWRY, P.E.  
 4122 POND HILL ROAD, SUITE 101  
 SAN ANTONIO, TX 78231  
 TEL: (210) 681-2951  
 FAX: (210) 523-7112

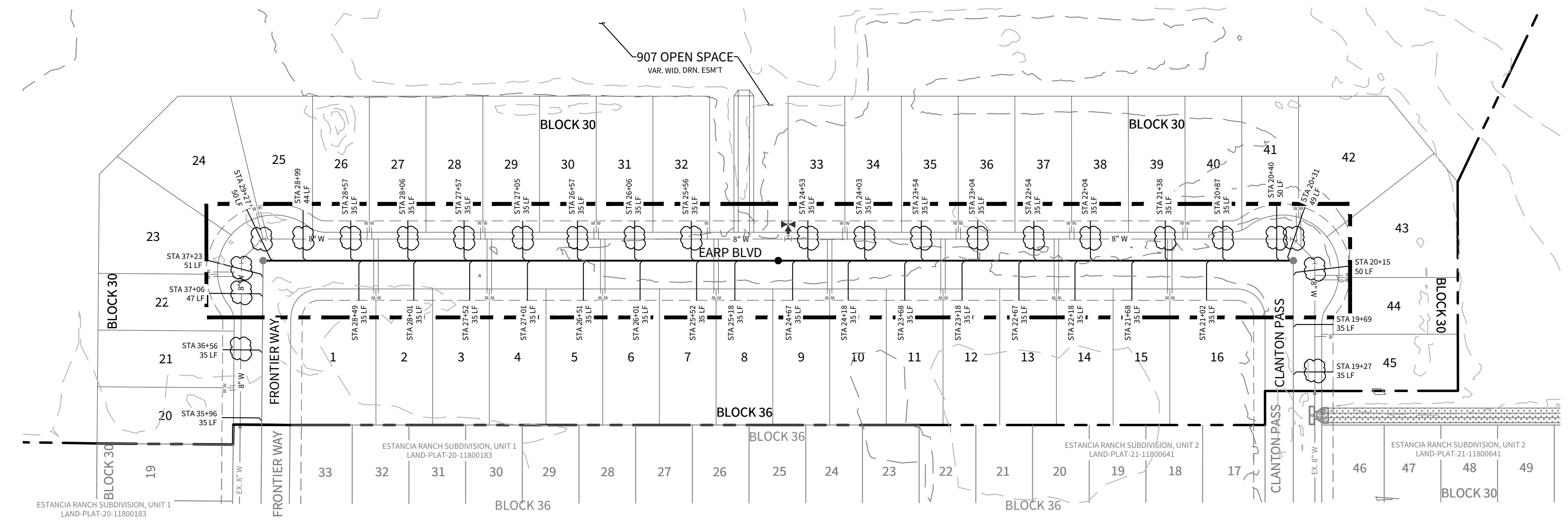

**NORTH**

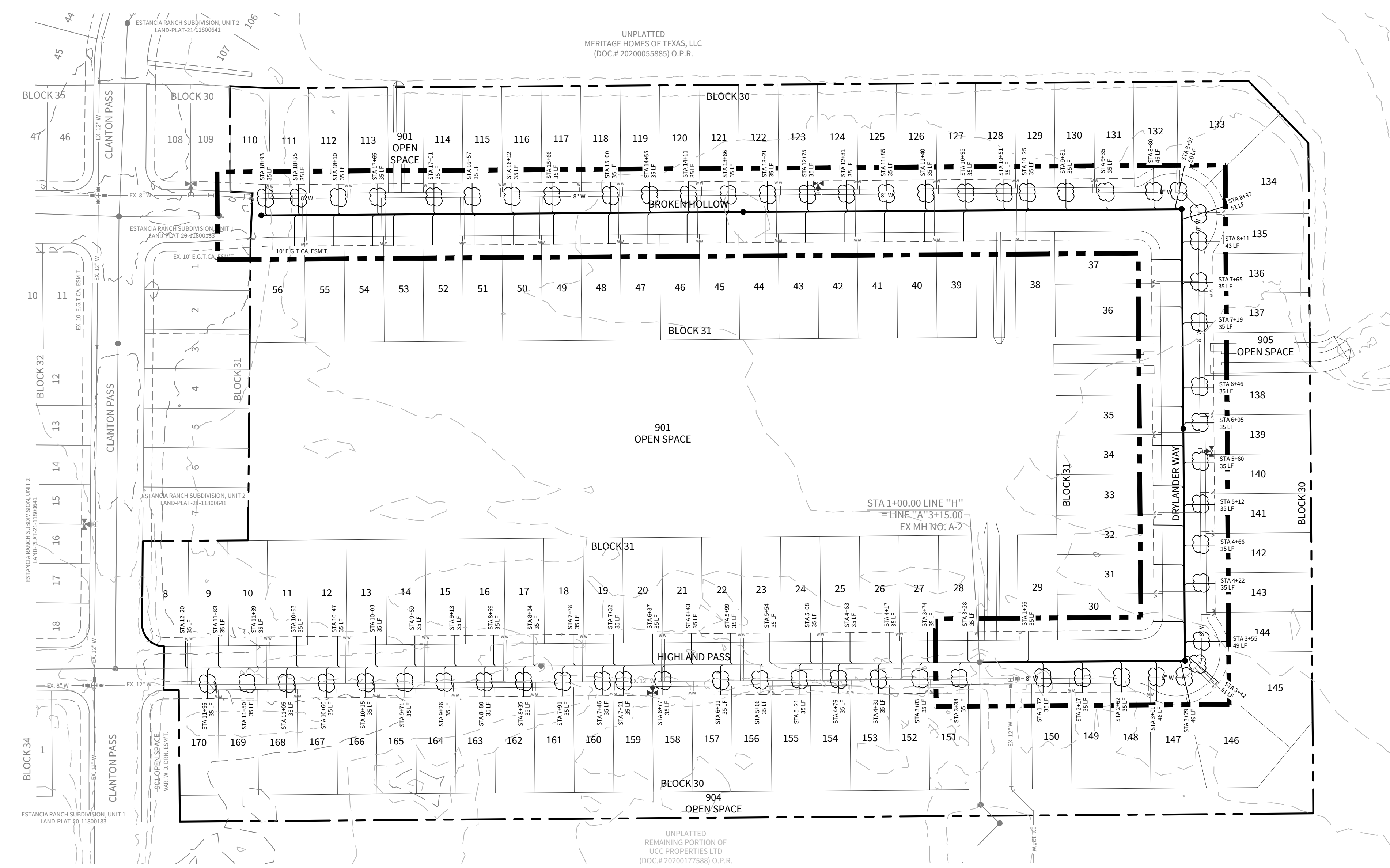

**SOUTH**

© 2023 M.W. CUDE ENGINEERS, L.L.C. - THIS DOCUMENT, ANY PORTION THEREOF, AND ANY ASSOCIATED COPYRIGHTS SHALL REMAIN THE PROPERTY OF M.W. CUDE ENGINEERS, L.L.C. THIS DOCUMENT MAY NOT BE REPRODUCED, USED, OR DISTRIBUTED IN ANY FORM OR BY ANY MEANS TO ANYONE FOR ANY OTHER ENDORSEMENT WITHOUT THE PRIOR WRITTEN CONSENT OF M.W. CUDE ENGINEERS, L.L.C. THIS DOCUMENT IS NOT INTENDED OR REPRESENTED TO BE SUITABLE FOR USE OTHER THAN AS ORIGINALLY INTENDED BY M.W. CUDE ENGINEERS, L.L.C. AND ANY UNAUTHORIZED REPRODUCTION, USE OR DISTRIBUTION OF SAID DOCUMENTS WILL BE AT THE INFRINGING PARTY'S SOLE RISK, WITHOUT ANY LIABILITY TO M.W. CUDE ENGINEERS, L.L.C. AND WILL BE USED AGAINST ANY AND ALL PARTIES TO THE FULLEST EXTENT PERMITTED BY LAW.



## ATTACHMENT F – SANITARY SEWER PLAN AND PROFILES

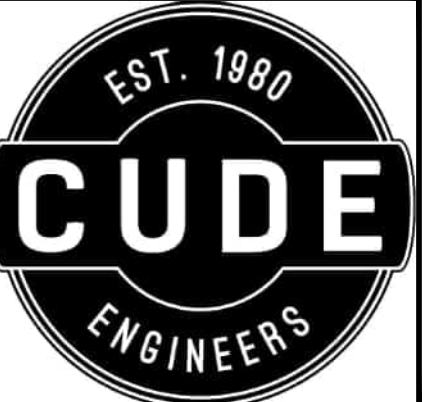

4122 Pond Hill Road, Suite 101  
San Antonio, Texas 78231  
P:(210) 681.2951 F:(210) 523.7112

ESTANCIA RANCH SUBDIVISION  
UNIT 3  
SANITARY SEWER PLAN & PROFILE EX LINE A

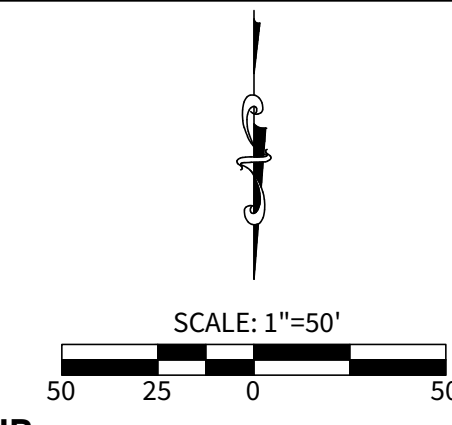

LEGEND

OVERALL UNIT BOUNDARY	---
PROPOSED LOT LINE	---
PROPOSED RIGHT OF WAY	---
E.G.T.C.A. EASEMENT	---
SANITARY SEWER ENVELOPE	---
EXISTING 2' CONTOUR	---
EXISTING 10' CONTOUR	---
EXISTING WATER LINE	---
EXISTING SEWER LINE	---
EXISTING MANHOLE	●
PROPOSED WATER LINE	---
PROPOSED SEWER MAIN	---
PROPOSED MANHOLE	●

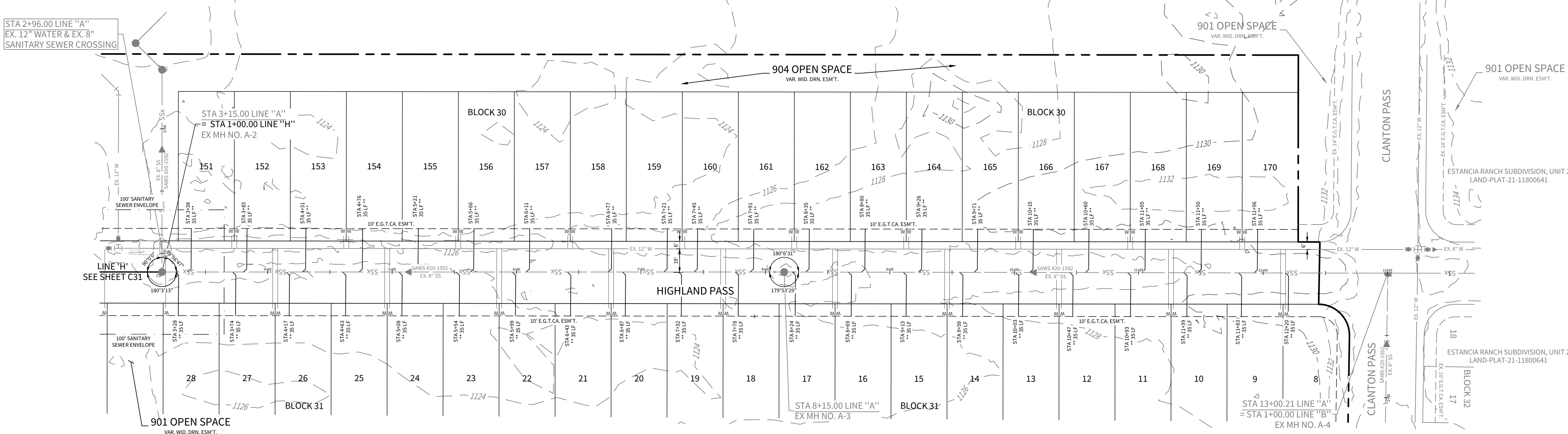

\*\* CONTRACTOR TO INSTALL CONCRETE SADDLE ON EXISTING SANITARY SEWER LINE AT EVERY PROPOSED LATERAL PER SAWS SPECIFICATIONS. SEE SHEET C32 FOR SAWS STANDARD DETAIL.

**TRENCH EXCAVATION PROTECTION**  
CONTRACTOR AND/OR CONTRACTORS INDEPENDENTLY RETAINED EMPLOYEE OR STRUCTURAL DESIGNER/GEOTECHNICAL/SAFETY/EQUIPMENT CONSULTANT, IF ANY, SHALL REVIEW THESE PLANS AND AVAILABLE GEOTECHNICAL INFORMATION AND THE ANTICIPATED INSTALLATION SITE(S) WITHIN THE PROJECT WORK AREA IN ORDER TO IMPLEMENT CONTRACTORS TRENCH EXCAVATION SAFETY PROTECTION SYSTEMS, PROGRAMS AND/OR PROCEDURES FOR THE PROJECT DESCRIBED IN THE CONTRACT DOCUMENTS. THE CONTRACTORS IMPLEMENTATION OF THESE SYSTEMS, PROGRAMS AND/OR PROCEDURES SHALL PROVIDE FOR ADEQUATE TRENCH EXCAVATION SAFETY PROTECTION THAT COMPLY WITH AS A MINIMUM, OSHA STANDARDS FOR TRENCH EXCAVATIONS. SPECIFICALLY, CONTRACTOR AND/OR CONTRACTORS INDEPENDENTLY RETAINED EMPLOYEE OR SAFETY CONSULTANT SHALL IMPLEMENT A TRENCH SAFETY PROGRAM IN ACCORDANCE WITH OSHA STANDARDS GOVERNING THE PRESENCE AND ACTIVITIES OF INDIVIDUALS WORKING IN AND AROUND TRENCH EXCAVATION.

CIBOLO CREEK & MEUSEBACH CREEK WATER SHED

Developer's Name	HERITAGE HOMES OF TEXAS, L.L.C.		
Developer's Address	2722 WEST BITTERS ROAD, SUITE 200		
City	SAN ANTONIO	State	TEXAS
Zip	78231		
Phone #	(210) 298-4294	Fax #	
SAWS Block Map #	084-618	Total EDU's	152
Total Linear Footage of Pipe	2,706.71 L.F. OF 8" S.S. - SDR 26	Plat No.	20-11800329
Number of Lots	152	SAWS Job No.	20-1592

**EX. LINE "A"**  
STA. 3+15.00 TO STA. 37+34.83

HORIZONTAL SCALE: 1" = 50'  
VERTICAL SCALE: 1" = 5'

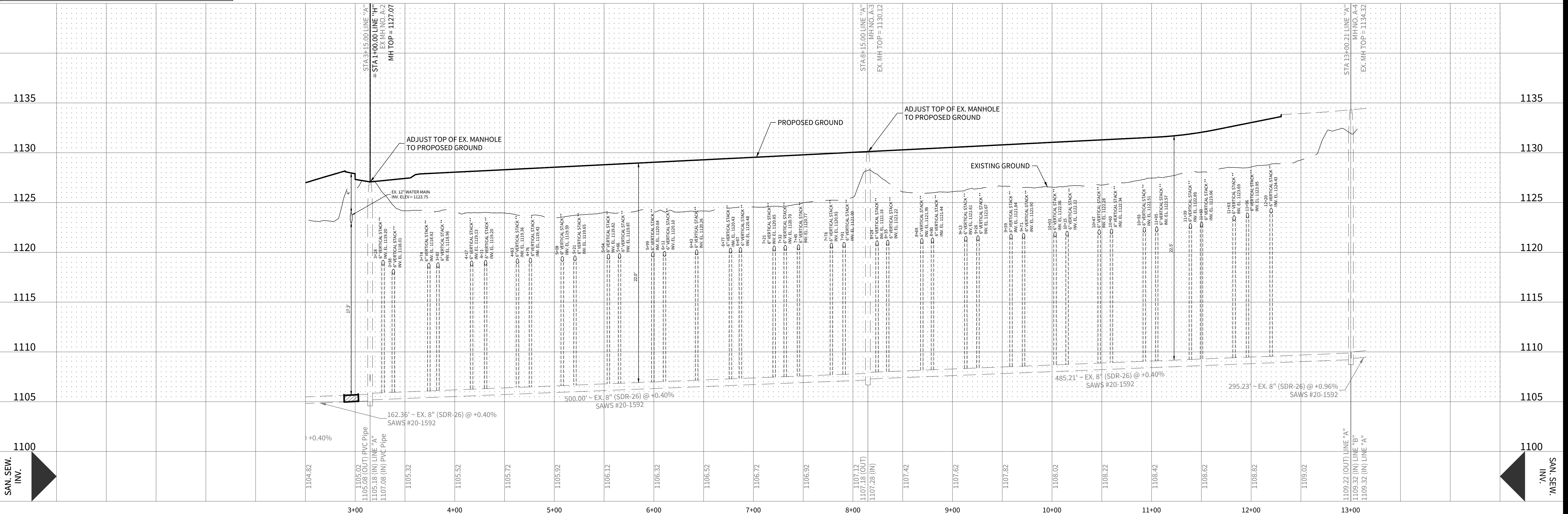

DATE: 10/26/2023  
PROJECT NO.: 03473.010  
DRAWN BY: CG/TCD/XV  
CHECKED BY: XV/AL

REVISIONS

DATE	REVISIONS
1	
2	
3	
4	
5	
6	
7	
8	
9	

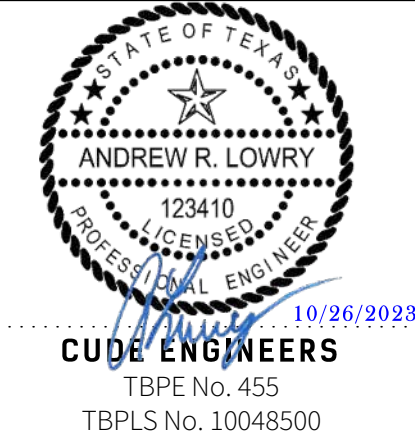

CUDE ENGINEERS  
TBPE No. 455  
TBPLS No. 10048500

PLAT NO.: 23-11800329  
SAWS JOB NO.: XX-XXXX

© 2022 M.W. CUDE ENGINEERS, L.L.C. - THIS DOCUMENT, ANY PORTION THEREOF, AND ANY ASSOCIATED COPYRIGHTS SHALL REMAIN THE PROPERTY OF M.W. CUDE ENGINEERS, L.L.C. THIS DOCUMENT IS NOT TO BE REPRODUCED, COPIED, OR DISTRIBUTED IN ANY FORM OR BY ANY MEANS TO ANYONE FOR ANY OTHER ENDORSEMENT WITHOUT THE PRIOR WRITTEN CONSENT OF M.W. CUDE ENGINEERS, L.L.C. ANY UNAUTHORIZED REPRODUCTION, USE OR DISTRIBUTION OF THIS DOCUMENT WILL BE AT THE REPRODUCER'S SOLE RISK, WITHOUT ANY LIABILITY TO M.W. CUDE ENGINEERS, L.L.C. AND WILL BE USED AGAINST ANY AND ALL PARTIES TO THE GREATEST EXTENT PERMITTED BY LAW.

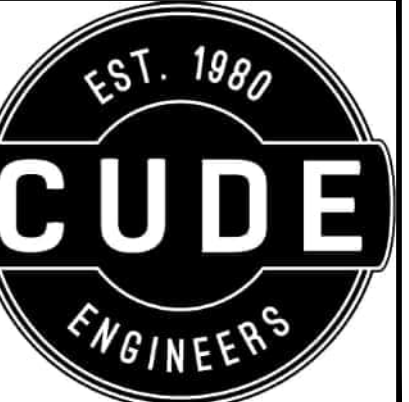

4122 Pond Hill Road, Suite 101  
San Antonio, Texas 78231  
P:(210) 681.2951 F:(210) 523.7112



SCALE: 1"=50'

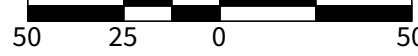

LEGEND

- OVERALL UNIT BOUNDARY
- PROPOSED LOT LINE
- PROPOSED RIGHT OF WAY
- E.G.T.CA. EASEMENT
- SANITARY SEWER ENVELOPE
- EXISTING 2' CONTOUR
- EXISTING 10' CONTOUR
- EXISTING WATER LINE
- EXISTING SEWER LINE
- EXISTING MANHOLE
- PROPOSED WATER LINE
- PROPOSED SEWER MAIN
- PROPOSED MANHOLE

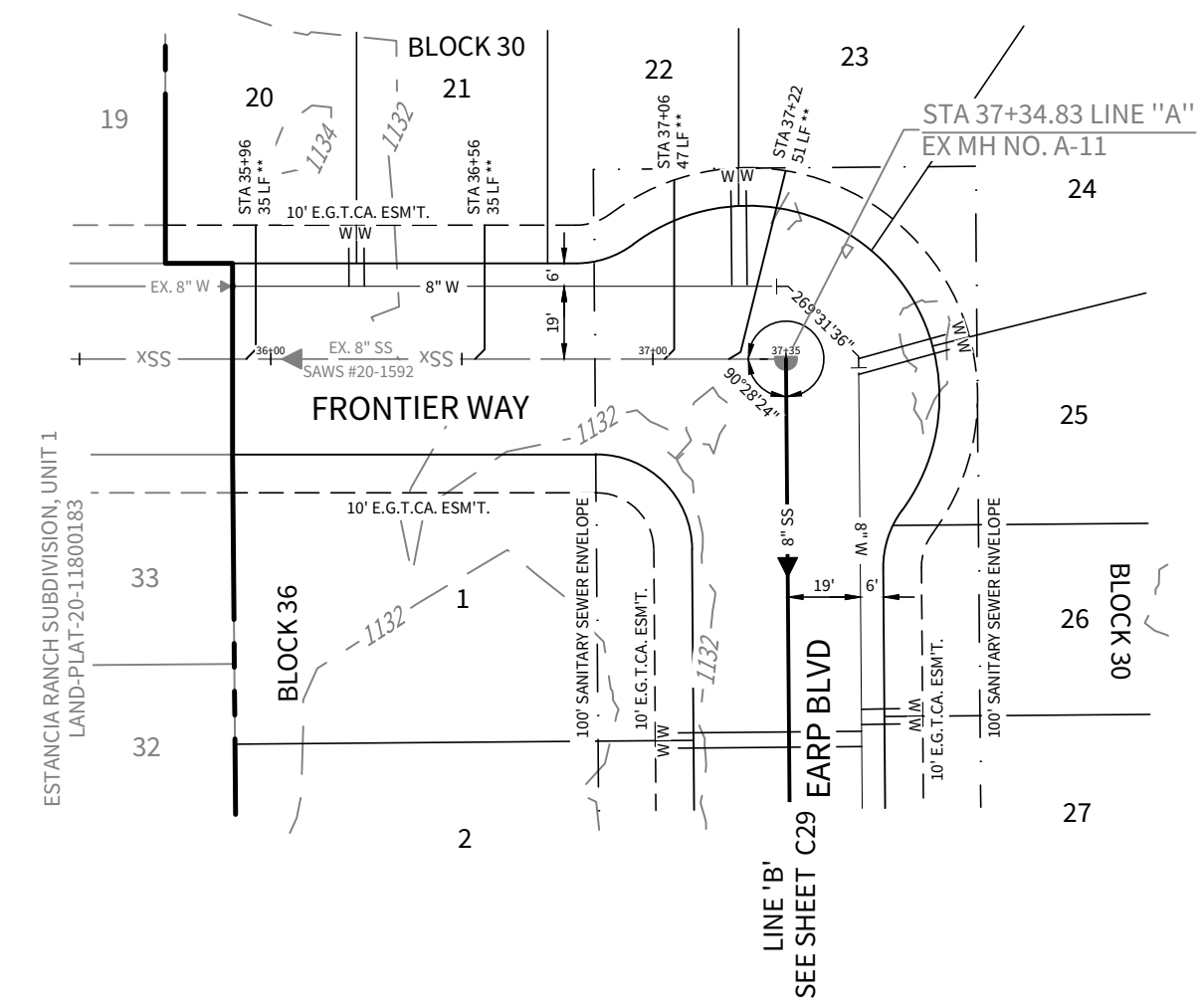

\*\* CONTRACTOR TO INSTALL CONCRETE SADDLE ON EXISTING SANITARY SEWER LINE AT EVERY PROPOSED LATERAL PER SAWS SPECIFICATIONS. SEE SHEET C32 FOR SAWS STANDARD DETAIL.

**TRENCH EXCAVATION PROTECTION**  
 CONTRACTOR AND/OR CONTRACTOR'S INDEPENDENTLY RETAINED EMPLOYEES OR STRUCTURAL DESIGN/GEOTECHNICAL/SAFETY/EQUIPMENT CONSULTANT, IF ANY, SHALL REVIEW THESE PLANS AND AVAILABLE GEOTECHNICAL INFORMATION AND THE ANTICIPATED INSTALLATION SITE(S) WITHIN THE PROJECT WORK AREA IN ORDER TO IMPLEMENT CONTRACTOR'S TRENCH EXCAVATION SAFETY PROTECTION SYSTEMS, PROGRAMS AND/OR PROCEDURES FOR THE PROJECT DESCRIBED IN THE CONTRACT DOCUMENTS. THE CONTRACTOR'S IMPLEMENTATION OF THESE SYSTEMS, PROGRAMS AND/OR PROCEDURES SHALL PROVIDE FOR ADEQUATE TRENCH EXCAVATION SAFETY PROTECTION THAT COMPLY WITH AS A MINIMUM, OSHA STANDARDS FOR TRENCH EXCAVATIONS. SPECIFICALLY, CONTRACTOR AND/OR CONTRACTOR'S INDEPENDENTLY RETAINED EMPLOYEE OR SAFETY CONSULTANT SHALL IMPLEMENT A TRENCH SAFETY PROGRAM IN ACCORDANCE WITH OSHA STANDARDS GOVERNING THE PRESENCE AND ACTIVITIES OF INDIVIDUALS WORKING IN AND AROUND TRENCH EXCAVATION.

CIBOLO CREEK & MEUSEBACH CREEK WATER SHED

Developer's Name	HERITAGE HOMES OF TEXAS, L.L.C.		
Developer's Address	2722 WEST BITTERS ROAD, SUITE 200		
City	SAN ANTONIO	State	TEXAS
		Zip	78231
Phone #	(210) 298-4294	Fax #	
SAWS Block Map #	084-018	Total EDU's	152
		Total Acreage	61.38
Total Linear Footage of Pipe	2,706.71 L.F. OF 8" SS - SDR 26	Plat No.	20-11800329
Number of Lots	152	SAWS Job No.	20-1592

# EX. LINE "A"

STA. 35+90.03 TO STA. 37+34.83

HORIZONTAL SCALE: 1" = 50'  
VERTICAL SCALE: 1" = 5'

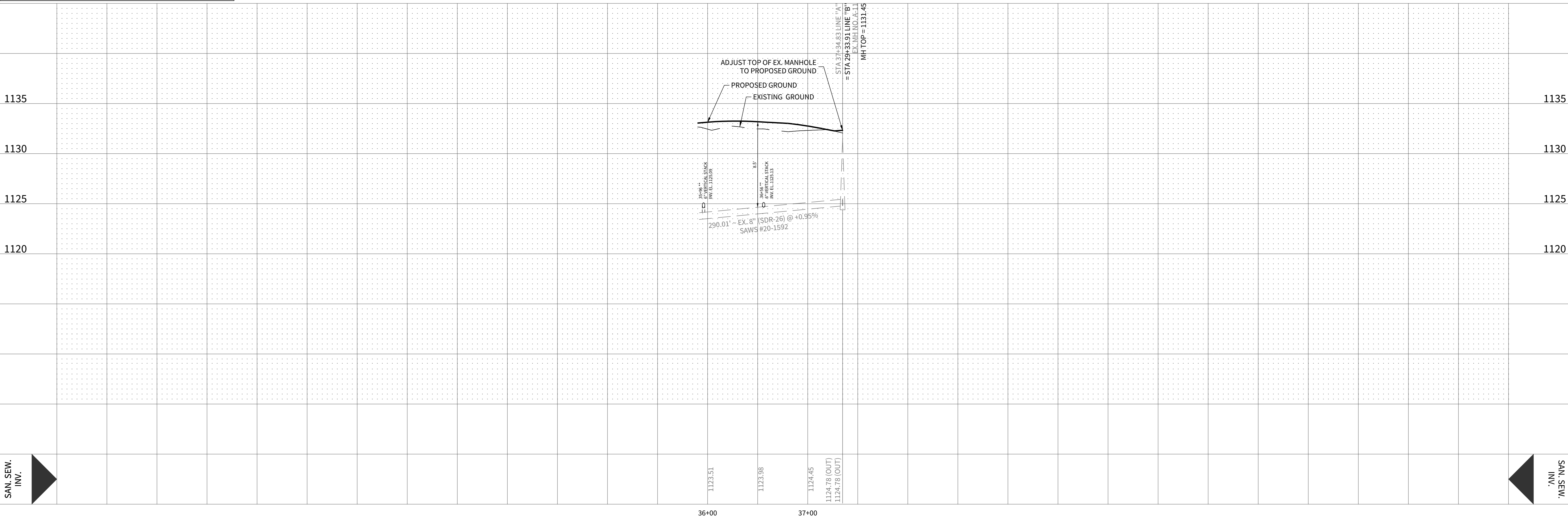

**ESTANCIA RANCH SUBDIVISION**  
**UNIT 3**  
 SANITARY SEWER PLAN & PROFILE EX LINE A

DATE	10/26/2023
PROJECT NO.	03473.010
DRAWN BY	CG/TCD/XV
CHECKED BY	XV/AL

REVISIONS	
DATE	1 2 3 4 5 6 7 8 9

STATE OF TEXAS  
 ANDREW R. LOWRY  
 123410  
 PROFESSIONAL ENGINEER  
 10/26/2023  
**CUDE ENGINEERS**  
 TBPE No. 455  
 TBPLS No. 10048500

PLAT NO.  
23-11800329  
 SAWS JOB NO.  
XX-XXXX

# C28

© 2023 M.W. CUDE ENGINEERS, L.L.C. - THIS DOCUMENT, ANY PORTION THEREOF, AND ANY ASSOCIATED COPYRIGHTS SHALL REMAIN THE PROPERTY OF M.W. CUDE ENGINEERS, L.L.C. THIS DOCUMENT IS NOT TO BE REPRODUCED, USED, OR DISTRIBUTED IN ANY FORM OR BY ANY MEANS TO ANYONE FOR ANY OTHER ENDORSEMENT WITHOUT THE PRIOR WRITTEN CONSENT OF M.W. CUDE ENGINEERS, L.L.C. THIS DOCUMENT IS NOT INTENDED OR REPRESENTED TO BE SUITABLE FOR USE OTHER THAN AS ORIGINALLY INTENDED BY M.W. CUDE ENGINEERS, L.L.C. AND ANY UNAUTHORIZED REPRODUCTION, USE OR DISTRIBUTION OF SAID DOCUMENTS WILL BE AT THE INFRINGING PARTY'S SOLE RISK, WITHOUT ANY LIABILITY TO M.W. CUDE ENGINEERS, L.L.C. AND WILL BE USED AGAINST ANY AND ALL PARTIES TO THE FULLEST EXTENT PERMITTED BY LAW.

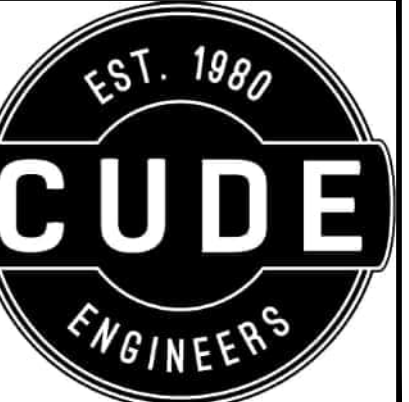

4122 Pond Hill Road, Suite 101  
San Antonio, Texas 78231  
P: (210) 681.2951 F: (210) 523.7112

ESTANCIA RANCH SUBDIVISION  
UNIT 3  
SANITARY SEWER PLAN & PROFILE LINE B

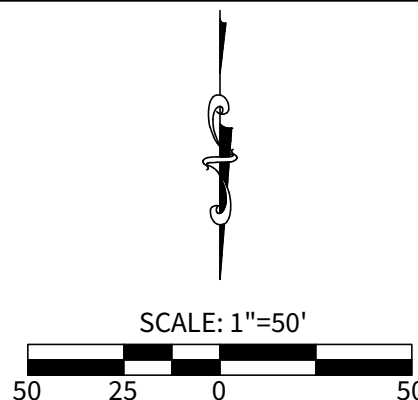

**LEGEND**

OVERALL UNIT BOUNDARY	---
PROPOSED LOT LINE	---
PROPOSED RIGHT OF WAY	---
E.G.T.C.A. EASEMENT	---
SANITARY SEWER ENVELOPE	---
EXISTING 2' CONTOUR	--- 2' ---
EXISTING 10' CONTOUR	--- 10' ---
EXISTING WATER LINE	---
EXISTING SEWER LINE	---
EXISTING MANHOLE	●
PROPOSED WATER LINE	---
PROPOSED SEWER MAIN	---
PROPOSED MANHOLE	●

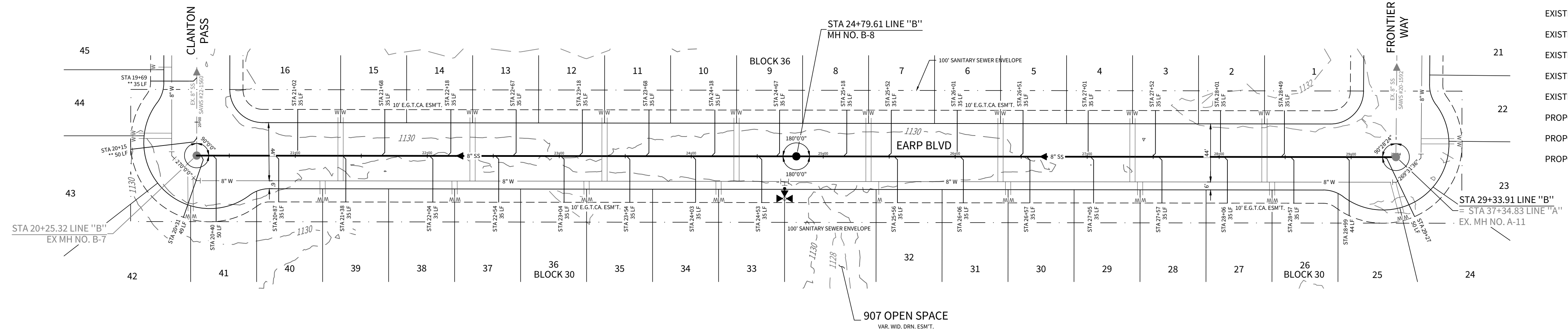

\*\* CONTRACTOR TO INSTALL CONCRETE SADDLE ON EXISTING SANITARY SEWER LINE AT EVERY PROPOSED LATERAL PER SAWS SPECIFICATIONS. SEE SHEET C32 FOR SAWS STANDARD DETAIL.

**TRENCH EXCAVATION PROTECTION**  
CONTRACTOR AND/OR CONTRACTOR'S INDEPENDENTLY RETAINED EMPLOYEES OR STRUCTURAL DESIGN/GEOTECHNICAL/SAFETY/EQUIPMENT CONSULTANT, IF ANY, SHALL REVIEW THESE PLANS AND AVAILABLE GEOTECHNICAL INFORMATION AND THE ANTICIPATED INSTALLATION SITE(S) WITHIN THE PROJECT WORK AREA IN ORDER TO IMPLEMENT CONTRACTOR'S TRENCH EXCAVATION SAFETY PROTECTION SYSTEMS, PROGRAMS AND/OR PROCEDURES FOR THE PROJECT DESCRIBED IN THE CONTRACT DOCUMENTS. THE CONTRACTOR'S IMPLEMENTATION OF THESE SYSTEMS, PROGRAMS AND/OR PROCEDURES SHALL PROVIDE FOR ADEQUATE TRENCH EXCAVATION SAFETY PROTECTION THAT COMPLY WITH AS A MINIMUM, OSHA STANDARDS FOR TRENCH EXCAVATIONS. SPECIFICALLY, CONTRACTOR AND/OR CONTRACTOR'S INDEPENDENTLY RETAINED EMPLOYEES OR SAFETY CONSULTANT SHALL IMPLEMENT A TRENCH SAFETY PROGRAM IN ACCORDANCE WITH OSHA STANDARDS GOVERNING THE PRESENCE AND ACTIVITIES OF INDIVIDUALS WORKING IN AND AROUND TRENCH EXCAVATION.

**CIBOLO CREEK & HEUSEBACH CREEK WATER SHED**

Developer's Name	MERITAGE HOMES OF TEXAS, L.L.C.		
Developer's Address	2722 WEST BITTERS ROAD, SUITE 200		
City	SAN ANTONIO	State	TEXAS
Zip	78231		
Phone #	(210) 298-4294	Fax #	
SAWS Block Map #	084-618	Total EDU's	152
Total Acreage	61.38		
Total Linear Footage of Pipe	2706.71 L.F. OF 8" SS - SDR 26	Plat No.	20-11800329
Number of Lots	152	SAWS Job No.	20-1592

**LINE "B"**  
STA. 20+25.32 TO STA. 29+33.91

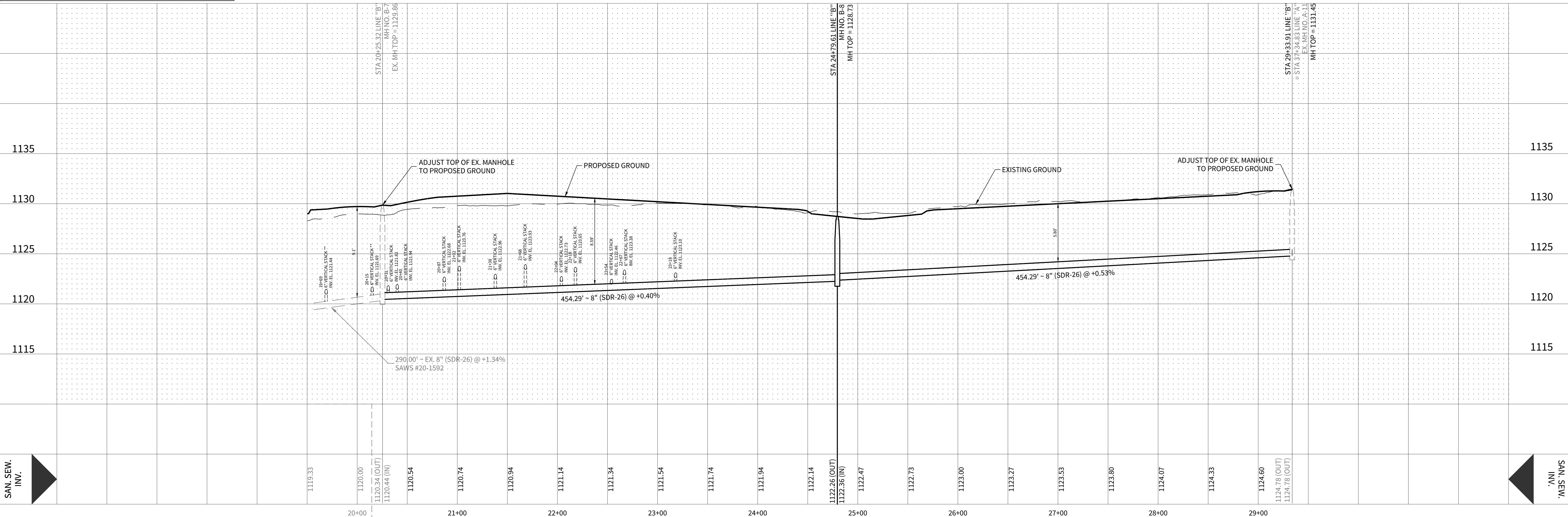

DATE	10/26/2023
PROJECT NO.	03473.010
DRAWN BY	CG/TCD/XV
CHECKED BY	XV/AL

REVISIONS

DATE	REVISIONS
1	
2	
3	
4	
5	
6	
7	
8	
9	

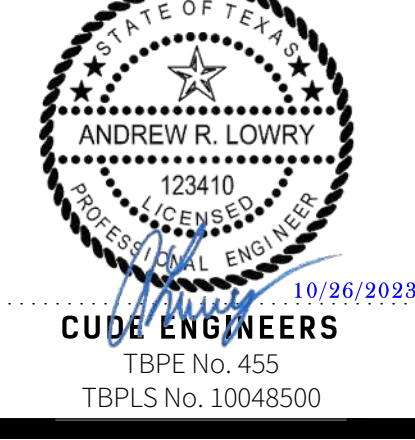

PLAT NO.  
23-11800329  
SAWS JOB NO.  
XX-XXXX

**C29**  
CUDEENGINEERS.COM

© 2023 M.W. CUDE ENGINEERS, L.L.C. - THIS DOCUMENT, ANY PORTION THEREOF, AND ANY ASSOCIATED COPYRIGHTS SHALL REMAIN THE PROPERTY OF M.W. CUDE ENGINEERS, L.L.C. THIS DOCUMENT IS NOT INTENDED OR REPRESENTED TO BE SUITABLE FOR USE OTHER THAN AS ORIGINALLY INTENDED BY M.W. CUDE ENGINEERS, L.L.C. AND FOR ANY OTHER ENDORSEMENT WITHOUT THE PRIOR WRITTEN CONSENT OF M.W. CUDE ENGINEERS, L.L.C. ANY UNAUTHORIZED REPRODUCTION, USE OR DISTRIBUTION OF SAID DOCUMENTS WILL BE AT THE REPRODUCER'S SOLE RISK, WITHOUT ANY LIABILITY TO M.W. CUDE ENGINEERS, L.L.C. AND WILL BE USED AGAINST ANY AND ALL PARTIES TO THE FULLEST EXTENT PERMITTED BY LAW.

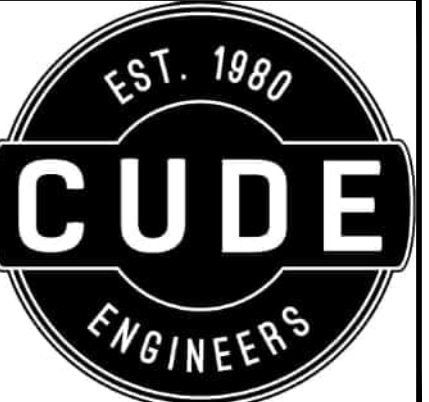

4122 Pond Hill Road, Suite 101  
San Antonio, Texas 78231  
P:(210) 681.2951 F:(210) 523.7112

**ESTANCIA RANCH SUBDIVISION**  
**UNIT 3**  
SANITARY SEWER PLAN & PROFILE LINE H



SCALE: 1"=50'  
50 25 0 50

**LEGEND**

- OVERALL UNIT BOUNDARY
- PROPOSED LOT LINE
- PROPOSED RIGHT OF WAY
- E.G.T.CA. EASEMENT
- SANITARY SEWER ENVELOPE
- EXISTING 2' CONTOUR
- EXISTING 10' CONTOUR
- EXISTING WATER LINE
- EXISTING SEWER LINE
- EXISTING MANHOLE
- PROPOSED WATER LINE
- PROPOSED SEWER MAIN
- PROPOSED MANHOLE

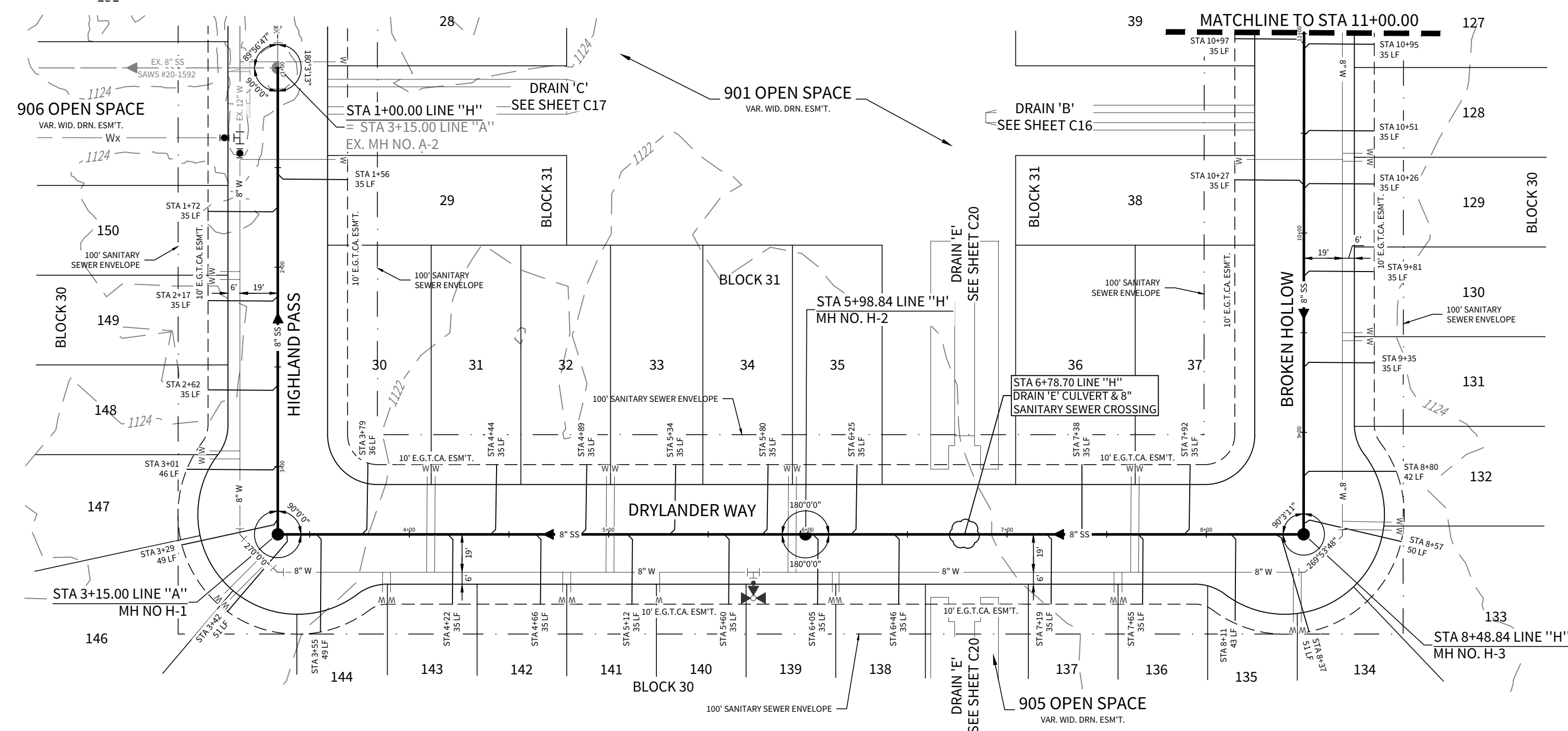

# LINE "H"

STA. 1+00.00 TO STA. 11+00.00

HORIZONTAL SCALE: 1" = 50'  
VERTICAL SCALE: 1" = 5'

**TRENCH EXCAVATION PROTECTION**  
CONTRACTOR AND/OR CONTRACTORS INDEPENDENTLY RETAINED EMPLOYEES OR STRUCTURAL DESIGN/GEOTECHNICAL/SAFETY/EQUIPMENT CONSULTANT, IF ANY, SHALL REVIEW THESE PLANS AND AVAILABLE GEOTECHNICAL INFORMATION AND THE ANTICIPATED INSTALLATION SITE(S) WITHIN THE PROJECT WORK AREA IN ORDER TO IMPLEMENT CONTRACTORS TRENCH EXCAVATION SAFETY PROTECTION SYSTEMS, PROGRAMS AND/OR PROCEDURES FOR THE PROJECT DESCRIBED IN THE CONTRACT DOCUMENTS. THE CONTRACTORS IMPLEMENTATION OF THESE SYSTEMS, PROGRAMS AND/OR PROCEDURES SHALL PROVIDE FOR ADEQUATE TRENCH EXCAVATION SAFETY PROTECTION THAT COMPLY WITH AS A MINIMUM, OSHA STANDARDS FOR TRENCH EXCAVATIONS. SPECIFICALLY, CONTRACTOR AND/OR CONTRACTORS INDEPENDENTLY RETAINED EMPLOYEES OR SAFETY CONSULTANT SHALL IMPLEMENT A TRENCH SAFETY PROGRAM IN ACCORDANCE WITH OSHA STANDARDS GOVERNING THE PRESENCE AND ACTIVITIES OF INDIVIDUALS WORKING IN AND AROUND TRENCH EXCAVATION.

CIBOLO CREEK & MEUSEBACH CREEK WATER SHED

Developer's Name	MERITAGE HOMES OF TEXAS, L.L.C.		
Developer's Address	2722 WEST BITTERS ROAD, SUITE 200		
City	SAN ANTONIO	State	TEXAS
Zip	78231		
Phone #	(210) 298-4294	Fax #	
SAWS Block Map #	084-618	Total EDU's	152
Total Acreage	61.38		
Total Linear Footage of Pipe	2,706.71 L.F. OF 8" SS	SDR 26	Plat No. 20-11800329
Number of Lots	152	SAWS Job No.	20-1592

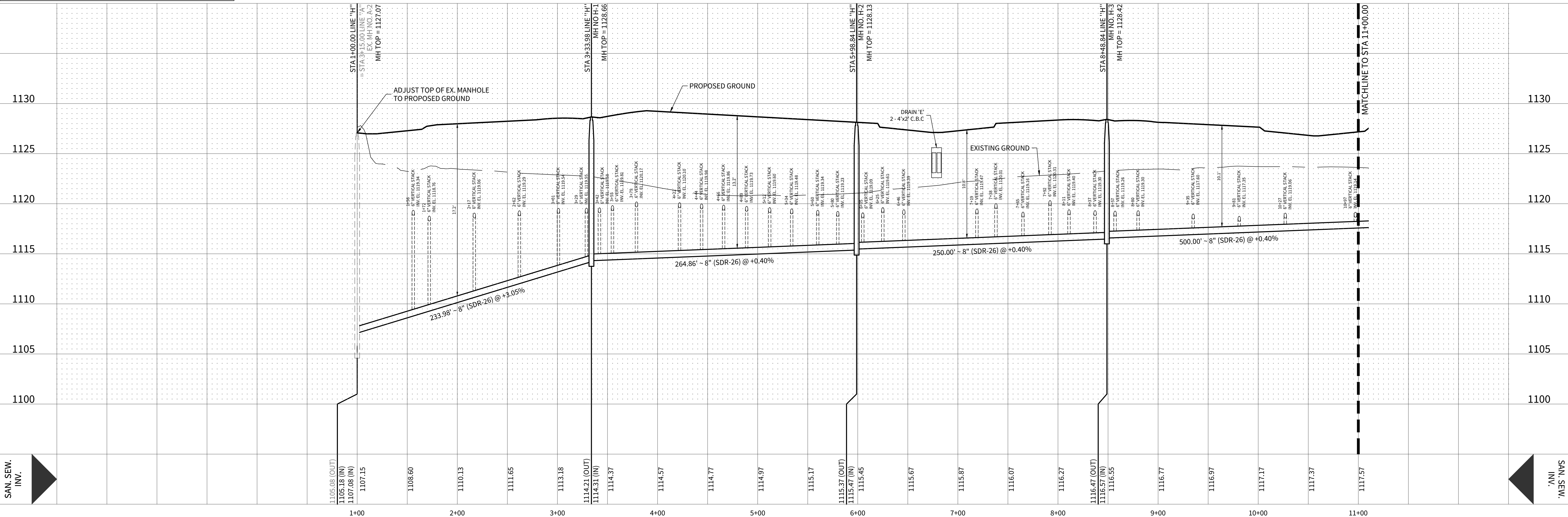

DATE	10/26/2023
PROJECT NO.	03473.010
DRAWN BY	CG/TCD/XV
CHECKED BY	XV/AL

REVISIONS	
DATE	1 2 3 4 5 6 7 8 9

STATE OF TEXAS  
ANDREW R. LOWRY  
123410  
PROFESSIONAL ENGINEER  
10/26/2023  
CUDE ENGINEERS  
TBPE No. 455  
TBPLS No. 10048500

PLAT NO.  
23-11800329  
SAWS JOB NO.  
XX-XXXX

# C30

© 2023 M.W. CUDE ENGINEERS, L.L.C. - THIS DOCUMENT, ANY PORTION THEREOF, AND ANY ASSOCIATED COPYRIGHTS SHALL REMAIN THE PROPERTY OF M.W. CUDE ENGINEERS, L.L.C. THIS DOCUMENT IS NOT TO BE REPRODUCED, COPIED, OR DISTRIBUTED IN ANY FORM OR BY ANY MEANS TO ANYONE FOR ANY OTHER ENDORSEMENT WITHOUT THE PRIOR WRITTEN CONSENT OF M.W. CUDE ENGINEERS, L.L.C. ANY UNAUTHORIZED REPRODUCTION, USE OR DISTRIBUTION OF THIS DOCUMENT WILL BE AT THE INFRINGER'S SOLE RISK. THIS DOCUMENT IS NOT INTENDED OR REPRESENTED TO BE SUITABLE FOR USE OTHER THAN AS ORIGINALLY INTENDED BY M.W. CUDE ENGINEERS, L.L.C. AND ANY UNAUTHORIZED REPRODUCTION, USE OR DISTRIBUTION OF THIS DOCUMENT WILL BE AT THE INFRINGER'S SOLE RISK.



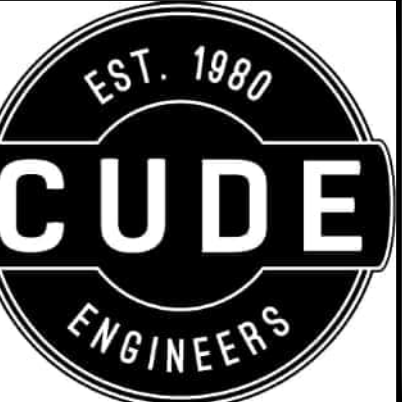

4122 Pond Hill Road, Suite 101  
San Antonio, Texas 78231  
P:(210) 681.2951 F:(210) 523.7112

**ESTANCIA RANCH SUBDIVISION  
UNIT 3**  
SANITARY SEWER PLAN & PROFILE LINE H

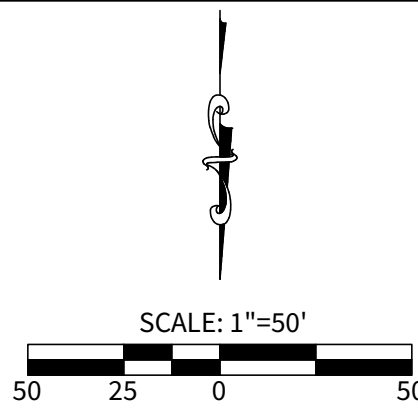

**LEGEND**

OVERALL UNIT BOUNDARY	---
PROPOSED LOT LINE	---
PROPOSED RIGHT OF WAY	---
E.G.T.C.A. EASEMENT	---
SANITARY SEWER ENVELOPE	---
EXISTING 2' CONTOUR	--- 499 ---
EXISTING 10' CONTOUR	--- 500 ---
EXISTING WATER LINE	---
EXISTING SEWER LINE	---
EXISTING MANHOLE	●
PROPOSED WATER LINE	---
PROPOSED SEWER MAIN	---
PROPOSED MANHOLE	●

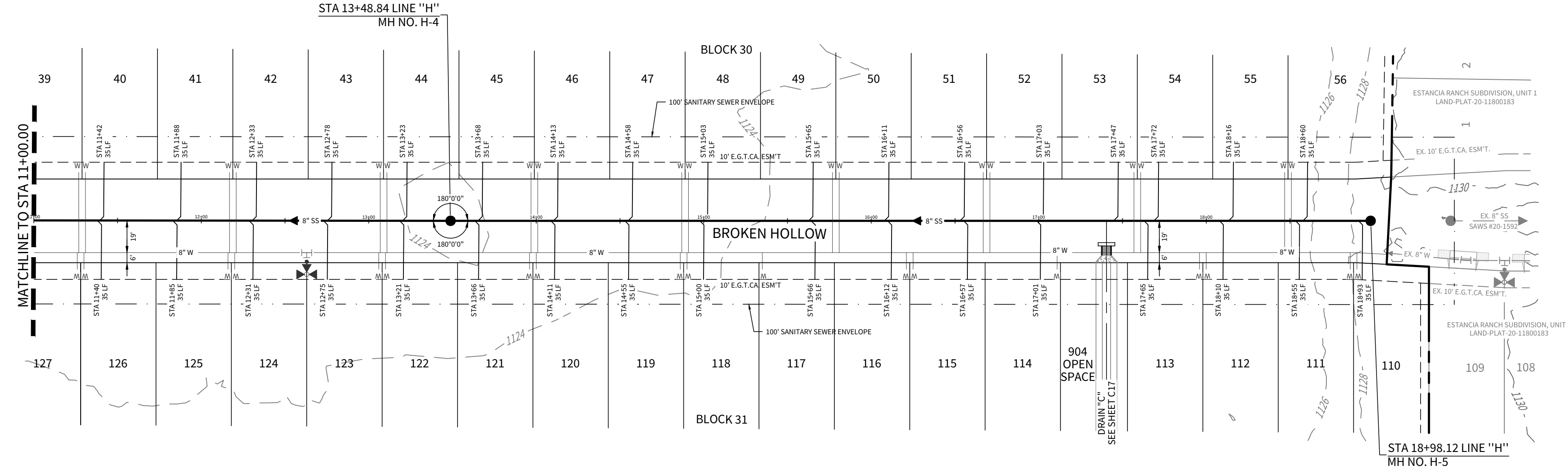

**LINE "H"**  
STA. 11+00.00 TO STA. 18+98.12

HORIZONTAL SCALE: 1" = 50'  
VERTICAL SCALE: 1" = 5'

**TRENCH EXCAVATION PROTECTION**  
CONTRACTOR AND/OR CONTRACTORS INDEPENDENTLY RETAINED EMPLOYEES OR STRUCTURAL DESIGN/GEOTECHNICAL/SAFETY/EQUIPMENT CONSULTANT, IF ANY, SHALL REVIEW THESE PLANS AND AVAILABLE GEOTECHNICAL INFORMATION AND THE ANTICIPATED INSTALLATION SITE(S) WITHIN THE PROJECT WORK AREA IN ORDER TO IMPLEMENT CONTRACTORS TRENCH EXCAVATION SAFETY PROTECTION SYSTEMS, PROGRAMS AND/OR PROCEDURES FOR THE PROJECT DESCRIBED IN THE CONTRACT DOCUMENTS. THE CONTRACTORS IMPLEMENTATION OF THESE SYSTEMS, PROGRAMS AND/OR PROCEDURES SHALL PROVIDE FOR ADEQUATE TRENCH EXCAVATION SAFETY PROTECTION THAT COMPLY WITH AS A MINIMUM, OSHA STANDARDS FOR TRENCH EXCAVATIONS. SPECIFICALLY, CONTRACTOR AND/OR CONTRACTORS INDEPENDENTLY RETAINED EMPLOYEES OR SAFETY CONSULTANT SHALL IMPLEMENT A TRENCH SAFETY PROGRAM IN ACCORDANCE WITH OSHA STANDARDS GOVERNING THE PRESENCE AND ACTIVITIES OF INDIVIDUALS WORKING IN AND AROUND TRENCH EXCAVATION.

**CIBOLO CREEK & MEUSEBACH CREEK WATER SHED**

Developer's Name	MERITAGE HOMES OF TEXAS, L.L.C.		
Developer's Address	2722 WEST BITTERS ROAD, SUITE 200		
City	SAN ANTONIO	State	TEXAS
Zip	78231		
Phone #	(210) 298-4294	Fax #	
SAWS Block Map #	084-618	Total EDU's	152
Total Acreage	61.38		
Total Linear Footage of Pipe	2706.71 L.F. OF 8" SS - SDR 26	Plot No.	20-11800329
Number of Lots	152	SAWS Job No.	20-1592

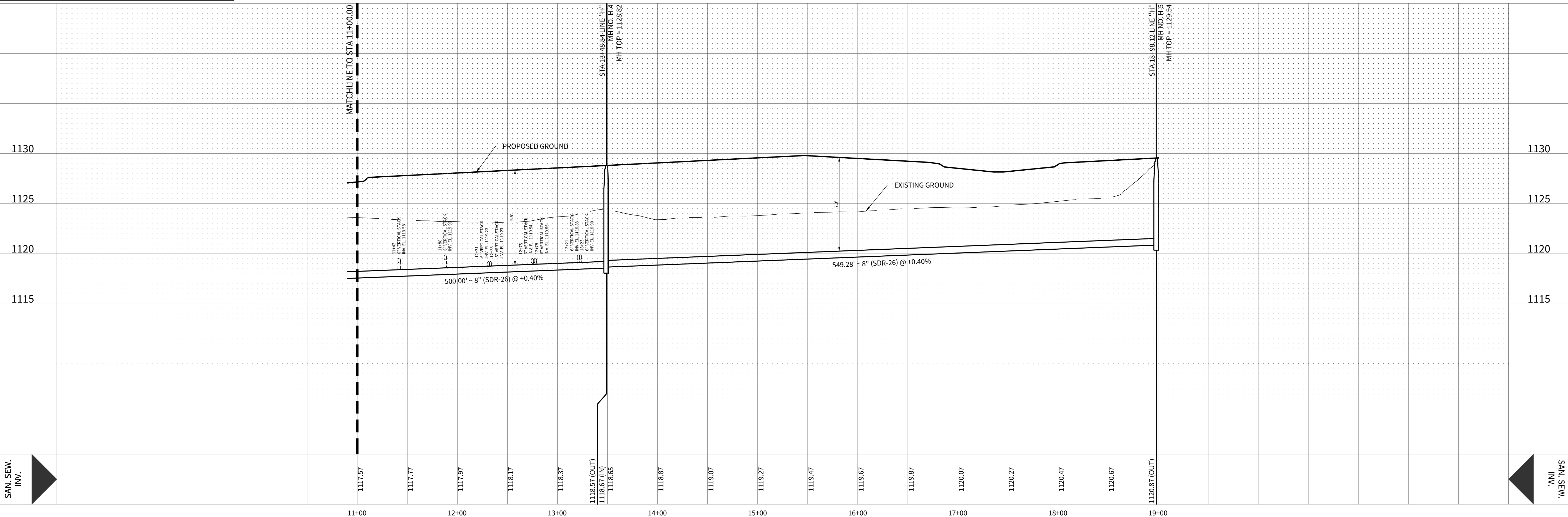

DATE	10/26/2023
PROJECT NO.	03473.010
DRAWN BY	CG/TCD/XV
CHECKED BY	XV/AL

REVISIONS	
DATE	
1	
2	
3	
4	
5	
6	
7	
8	
9	

STATE OF TEXAS  
ANDREW R. LOWRY  
123410  
PROFESSIONAL ENGINEER  
10/26/2023  
**CUDE ENGINEERS**  
TBPE No. 455  
TBPLS No. 10048500

**PLAT NO.**  
23-11800329  
**SAWS JOB NO.**  
XX-XXXX

**C31**

© 2023 M.W. CUDE ENGINEERS, L.L.C. - THIS DOCUMENT, ANY PORTION THEREOF, AND ANY ASSOCIATED COPYRIGHTS SHALL REMAIN THE PROPERTY OF M.W. CUDE ENGINEERS, L.L.C. THIS DOCUMENT IS NOT TO BE REPRODUCED, USED, OR DISTRIBUTED IN ANY FORM OR BY ANY MEANS TO ANYONE FOR ANY OTHER ENDORSEMENT WITHOUT THE PRIOR WRITTEN CONSENT OF M.W. CUDE ENGINEERS, L.L.C. THIS DOCUMENT IS NOT INTENDED OR REPRESENTED TO BE SUITABLE FOR USE OTHER THAN AS ORIGINALLY INTENDED BY M.W. CUDE ENGINEERS, L.L.C. AND ANY UNAUTHORIZED REPRODUCTION, USE OR DISTRIBUTION OF SAID DOCUMENTS WILL BE AT THE USER'S SOLE RISK. WITHOUT ANY LIABILITY TO M.W. CUDE ENGINEERS, L.L.C., AND WILL BE USED AGAINST ANY AND ALL PARTIES TO THE FULLEST EXTENT PERMITTED BY LAW.

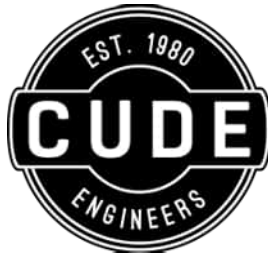

## ESTANCIA RANCH, UNIT 3

*LIFT STATION / FORCE MAIN APPLICATION  
NOT APPLICABLE*

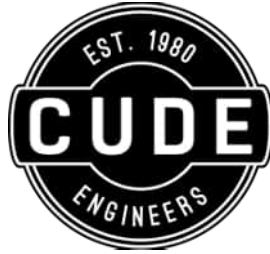

## ESTANCIA RANCH, UNIT 3

### *TEMPORARY STORMWATER SECTION (TCEQ-0602)*

# Temporary Stormwater Section

## Texas Commission on Environmental Quality

for Regulated Activities on the Edwards Aquifer Recharge Zone and Relating to 30 TAC §213.5(b)(4)(A), (B), (D)(I) and (G); Effective June 1, 1999

**To ensure that the application is administratively complete, confirm that all fields in the form are complete, verify that all requested information is provided, consistently reference the same site and contact person in all forms in the application, and ensure forms are signed by the appropriate party.**

**Note: Including all the information requested in the form and attachments contributes to more streamlined technical reviews.**

## Signature

To the best of my knowledge, the responses to this form accurately reflect all information requested concerning the proposed regulated activities and methods to protect the Edwards Aquifer. This **Temporary Stormwater Section** is hereby submitted for TCEQ review and executive director approval. The application was prepared by:

Print Name of Customer/Agent: Andrew R. Lowry

Date: 9/21/23

Signature of Customer/Agent:

 10/30/23

Regulated Entity Name: Estancia Ranch, Unit 3

## Project Information

### Potential Sources of Contamination

*Examples: Fuel storage and use, chemical storage and use, use of asphaltic products, construction vehicles tracking onto public roads, and existing solid waste.*

1. Fuels for construction equipment and hazardous substances which will be used during construction:

The following fuels and/or hazardous substances will be stored on the site: \_\_\_\_\_

These fuels and/or hazardous substances will be stored in:

- Aboveground storage tanks with a cumulative storage capacity of less than 250 gallons will be stored on the site for less than one (1) year.

- Aboveground storage tanks with a cumulative storage capacity between 250 gallons and 499 gallons will be stored on the site for less than one (1) year.
- Aboveground storage tanks with a cumulative storage capacity of 500 gallons or more will be stored on the site. An Aboveground Storage Tank Facility Plan application must be submitted to the appropriate regional office of the TCEQ prior to moving the tanks onto the project.
- Fuels and hazardous substances will not be stored on the site.
- 2.  **Attachment A - Spill Response Actions.** A site specific description of the measures to be taken to contain any spill of hydrocarbons or hazardous substances is attached.
- 3.  Temporary aboveground storage tank systems of 250 gallons or more cumulative storage capacity must be located a minimum horizontal distance of 150 feet from any domestic, industrial, irrigation, or public water supply well, or other sensitive feature.
- 4.  **Attachment B - Potential Sources of Contamination.** A description of any activities or processes which may be a potential source of contamination affecting surface water quality is attached.

### ***Sequence of Construction***

- 5.  **Attachment C - Sequence of Major Activities.** A description of the sequence of major activities which will disturb soils for major portions of the site (grubbing, excavation, grading, utilities, and infrastructure installation) is attached.
  - For each activity described, an estimate (in acres) of the total area of the site to be disturbed by each activity is given.
  - For each activity described, include a description of appropriate temporary control measures and the general timing (or sequence) during the construction process that the measures will be implemented.
- 6.  Name the receiving water(s) at or near the site which will be disturbed or which will receive discharges from disturbed areas of the project: Cibolo Creek

### ***Temporary Best Management Practices (TBMPs)***

*Erosion control examples: tree protection, interceptor swales, level spreaders, outlet stabilization, blankets or matting, mulch, and sod. Sediment control examples: stabilized construction exit, silt fence, filter dikes, rock berms, buffer strips, sediment traps, and sediment basins. Please refer to the Technical Guidance Manual for guidelines and specifications. All structural BMPs must be shown on the site plan.*

- 7.  **Attachment D – Temporary Best Management Practices and Measures.** TBMPs and measures will prevent pollution of surface water, groundwater, and stormwater. The construction-phase BMPs for erosion and sediment controls have been designed to retain sediment on site to the extent practicable. The following information is attached:

- A description of how BMPs and measures will prevent pollution of surface water, groundwater or stormwater that originates upgradient from the site and flows across the site.
  - A description of how BMPs and measures will prevent pollution of surface water or groundwater that originates on-site or flows off site, including pollution caused by contaminated stormwater runoff from the site.
  - A description of how BMPs and measures will prevent pollutants from entering surface streams, sensitive features, or the aquifer.
  - A description of how, to the maximum extent practicable, BMPs and measures will maintain flow to naturally-occurring sensitive features identified in either the geologic assessment, TCEQ inspections, or during excavation, blasting, or construction.
8.  The temporary sealing of a naturally-occurring sensitive feature which accepts recharge to the Edwards Aquifer as a temporary pollution abatement measure during active construction should be avoided.
- Attachment E - Request to Temporarily Seal a Feature.** A request to temporarily seal a feature is attached. The request includes justification as to why no reasonable and practicable alternative exists for each feature.
  - There will be no temporary sealing of naturally-occurring sensitive features on the site.
9.  **Attachment F - Structural Practices.** A description of the structural practices that will be used to divert flows away from exposed soils, to store flows, or to otherwise limit runoff discharge of pollutants from exposed areas of the site is attached. Placement of structural practices in floodplains has been avoided.
10.  **Attachment G - Drainage Area Map.** A drainage area map supporting the following requirements is attached:
- For areas that will have more than 10 acres within a common drainage area disturbed at one time, a sediment basin will be provided.
  - For areas that will have more than 10 acres within a common drainage area disturbed at one time, a smaller sediment basin and/or sediment trap(s) will be used.
  - For areas that will have more than 10 acres within a common drainage area disturbed at one time, a sediment basin or other equivalent controls are not attainable, but other TBMPs and measures will be used in combination to protect down slope and side slope boundaries of the construction area.
  - There are no areas greater than 10 acres within a common drainage area that will be disturbed at one time. A smaller sediment basin and/or sediment trap(s) will be used in combination with other erosion and sediment controls within each disturbed drainage area.

- There are no areas greater than 10 acres within a common drainage area that will be disturbed at one time. Erosion and sediment controls other than sediment basins or sediment traps within each disturbed drainage area will be used.
11.  **Attachment H - Temporary Sediment Pond(s) Plans and Calculations.** Temporary sediment pond or basin construction plans and design calculations for a proposed temporary BMP or measure have been prepared by or under the direct supervision of a Texas Licensed Professional Engineer. All construction plans and design information must be signed, sealed, and dated by the Texas Licensed Professional Engineer. Construction plans for the proposed temporary BMPs and measures are attached.
- N/A
12.  **Attachment I - Inspection and Maintenance for BMPs.** A plan for the inspection of each temporary BMP(s) and measure(s) and for their timely maintenance, repairs, and, if necessary, retrofit is attached. A description of the documentation procedures, recordkeeping practices, and inspection frequency are included in the plan and are specific to the site and/or BMP.
13.  All control measures must be properly selected, installed, and maintained in accordance with the manufacturer's specifications and good engineering practices. If periodic inspections by the applicant or the executive director, or other information indicate a control has been used inappropriately, or incorrectly, the applicant must replace or modify the control for site situations.
14.  If sediment escapes the construction site, off-site accumulations of sediment must be removed at a frequency sufficient to minimize offsite impacts to water quality (e.g., fugitive sediment in street being washed into surface streams or sensitive features by the next rain).
15.  Sediment must be removed from sediment traps or sedimentation ponds not later than when design capacity has been reduced by 50%. A permanent stake will be provided that can indicate when the sediment occupies 50% of the basin volume.
16.  Litter, construction debris, and construction chemicals exposed to stormwater shall be prevented from becoming a pollutant source for stormwater discharges (e.g., screening outfalls, picked up daily).

### ***Soil Stabilization Practices***

*Examples: establishment of temporary vegetation, establishment of permanent vegetation, mulching, geotextiles, sod stabilization, vegetative buffer strips, protection of trees, or preservation of mature vegetation.*

17.  **Attachment J - Schedule of Interim and Permanent Soil Stabilization Practices.** A schedule of the interim and permanent soil stabilization practices for the site is attached.

18.  Records must be kept at the site of the dates when major grading activities occur, the dates when construction activities temporarily or permanently cease on a portion of the site, and the dates when stabilization measures are initiated.
19.  Stabilization practices must be initiated as soon as practicable where construction activities have temporarily or permanently ceased.

### ***Administrative Information***

20.  All structural controls will be inspected and maintained according to the submitted and approved operation and maintenance plan for the project.
21.  If any geologic or manmade features, such as caves, faults, sinkholes, etc., are discovered, all regulated activities near the feature will be immediately suspended. The appropriate TCEQ Regional Office shall be immediately notified. Regulated activities must cease and not continue until the TCEQ has reviewed and approved the methods proposed to protect the aquifer from any adverse impacts.
22.  Silt fences, diversion berms, and other temporary erosion and sediment controls will be constructed and maintained as appropriate to prevent pollutants from entering sensitive features discovered during construction.



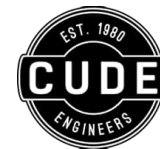

## ATTACHMENT A – SPILL RESPONSE ACTIONS

### Spill Prevention and Control

*The objective of this section is to describe measures to prevent or reduce the discharge of pollutants to drainage systems or watercourses from leaks and spills by reducing the chance for spills, stopping the source of spills, containing and cleaning up spills, properly disposing of spill materials, and training employees. The following steps will help reduce the storm water impacts of leaks and spills:*

### Education

- (1) Be aware that different materials pollute in different amounts. Make sure that each employee knows what a “significant spill” is for each material they use, and what is the appropriate response for “significant” and “insignificant” spills. Employees should also be aware of when spill must be reported to the TCEQ. Information available in 30 TAC 327.4 and 40 CFR 302.4.*
- (2) Educate employees and subcontractors on potential dangers to humans and the environment from spills and leaks.*
- (3) Hold regular meetings to discuss and reinforce appropriate disposal procedures (incorporate into regular safety meetings).*
- (4) Establish a continuing education program to indoctrinate new employees.*
- (5) Have contractor's superintendent or representative oversee and enforce proper spill prevention and control measures.*

### General Measures

- (1) To the extent that the work can be accomplished safely, spills of oil, petroleum products, and substances listed under 40 CFR parts 110,117, and 302, and sanitary and septic wastes should be contained and cleaned up immediately.*
- (2) Store hazardous materials and wastes in covered containers and protect from vandalism.*
- (3) Place a stockpile of spill cleanup materials where it will be readily accessible.*
- (4) Train employees in spill prevention and cleanup.*
- (5) Designate responsible individuals to oversee and enforce control measures.*
- (6) Spills should be covered and protected from stormwater runoff during rainfall to the extent that it doesn't compromise clean-up activities.*
- (7) Do not bury or wash spills with water.*
- (8) Store and dispose of used clean up materials, contaminated materials, and recovered spill material that is no longer suitable for the intended purpose in conformance with the provisions in applicable BMPs.*
- (9) Do not allow water used for cleaning and decontamination to enter storm drains or watercourses. Collect and dispose of contaminated water in accordance with applicable regulations.*
- (10) Contain water overflow or minor water spillage and do not allow it to discharge into drainage facilities or watercourses.*
- (11) Place Material Safety Data Sheets (MSDS), as well as proper storage, cleanup, and spill reporting instructions for hazardous materials stored or used on the project site in an open, conspicuous, and accessible location.*
- (12) Keep waste storage areas clean, well-organized, and equipped with ample cleanup supplies as appropriate for the materials being stored. Perimeter controls, containment structures, covers, and*

*liners should be repaired or replaced as needed to maintain proper function.*

### Cleanup

- (1) *Clean up leaks and spills immediately.*
- (2) *Use a rag for small spills on paved surfaces, a damp mop for general cleanup, and absorbent material for larger spills. If the spilled material is hazardous, then the used cleanup materials are also hazardous and must be disposed of as hazardous waste.*
- (3) *Never hose down or bury dry material spills. Clean up as much of the material as possible and dispose of properly. See the waste management BMPs in this section for specific information.*

### Minor Spills

- (1) *Minor spills typically involve small quantities of oil, gasoline, paint, etc. which can be controlled by the first responder at the discovery of the spill.*
- (2) *Use absorbent materials on small spills rather than hosing down or burying the spill.*
- (3) *Absorbent materials should be promptly removed and disposed of properly.*
- (4) *Follow the practice below for a minor spill:*
  - a) *Contain the spread of the spill.*
  - b) *Recover spilled materials.*
  - c) *Clean the contaminated area and properly dispose of contaminated materials.*

### Semi-significant Spills

*Semi-significant spills still can be controlled by the first responder along with the aid of other personnel such as laborers and the foreman, etc. This response may require the cessation of all other activities.*

*Spills should be cleaned up immediately:*

- (1) *Contain spread of the spill.*
- (2) *Notify the project foreman immediately.*
- (3) *If the spill occurs on paved or impermeable surfaces, clean up using "dry" methods (absorbent materials, cat litter and/or rags). Contain the spill by encircling with absorbent materials and do not let the spill spread widely.*
- (4) *If the spill occurs in dirt areas, immediately contain the spill by constructing an earthen dike. Dig up and properly dispose of contaminated soil.*
- (5) *If the spill occurs during rain, cover spill with tarps or other material to prevent contaminating runoff.*

### Significant/Hazardous Spills

*For significant or hazardous spills that are in reportable quantities:*

- (1) *Notify the TCEQ by telephone as soon as possible and within 24 hours at 512-339-2929 (Austin) or 210-490-3096 (San Antonio) between 8 AM and 5 PM. After hours, contact the Environmental Release Hotline at 1-800-832-8224. It is the contractor's responsibility to have all emergency phone numbers at the construction site.*
- (2) *For spills of federal reportable quantities, in conformance with the requirements in 40 CFR parts 110,119, and 302, the contractor should notify the National Response Center at (800) 424-8802.*
- (3) *Notification should first be made by telephone and followed up with a written report.*
- (4) *The services of a spills contractor or a Haz-Mat team should be obtained immediately. Construction personnel should not attempt to clean up until the appropriate and qualified staffs have arrived at the*

*job site.*

- (5) *Other agencies which may need to be consulted include, but are not limited to, the City Police Department, County Sheriff Office, Fire Departments, etc.*

*More information on spill rules and appropriate responses is available on the TCEQ website at:  
<http://www.tceq.texas.gov/response/spills.html>*

#### Vehicle and Equipment Maintenance

- (1) *If maintenance must occur onsite, use a designated area and a secondary containment, located away from drainage courses, to prevent the run-on of stormwater and the runoff of spills.*
- (2) *Regularly inspect onsite vehicles and equipment for leaks and repair immediately.*
- (3) *Check incoming vehicles and equipment (including delivery trucks, and employee and subcontractor vehicles) for leaking oil and fluids. Do not allow leaking vehicles or equipment onsite.*
- (4) *Always use secondary containment, such as a drain pan or drop cloth, to catch spills or leaks when removing or changing fluids.*
- (5) *Place drip pans or absorbent materials under paving equipment when not in use.*
- (6) *Use absorbent materials on small spills rather than hosing down or burying the spill. Remove the absorbent materials promptly and dispose of properly.*
- (7) *Promptly transfer used fluids to the proper waste or recycling drums. Don't leave fill drip pans or other open containers lying around.*
- (8) *Oil filters disposed of in trashcans or dumpsters can leak and pollute stormwater. Place the oil filter in a funnel over a waste oil-recycling drum to drain excess oil before disposal. Oil filters can also be recycled. Ask the oil supplier or recycler about recycling oil filters.*
- (9) *Store cracked batteries in a non-leaking secondary container. Do this with all cracked batteries even if you & think all the acid has drained out. If you drop a battery, treat it as if it is cracked. Put it into the containment area until you are sure it is not leaking.*

#### Vehicle and Equipment Fueling

- (1) *If fueling must occur on site, use designated areas, located away from drainage courses, to prevent the runoff of stormwater and the runoff of spills.*
- (2) *Discourage "topping off" of fuel tanks.*
- (3) *Always use secondary containment, such as a drain pan, when fueling to catch spills/leaks.*

#### Spill Response Actions

*In the event that a spill of hydrocarbons or hazardous substances does occur, the contractor shall be required to maintain a sufficient stockpile of sand material in the staging area. This sand material shall be used to immediately isolate and provide containment of the spill by constructing dikes. Furthermore, this sand material shall act as an absorbent material that can be disposed of offsite and out of the Recharge Zone during clean-up operations. The contractor, in the event of a spill, shall also notify the owner who shall contact TCEQ. All contaminated soils resulting from an accidental release will be required to be removed and disposed of in accordance with all local, state and federal regulations.*

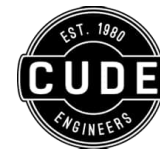

## ATTACHMENT B – POTENTIAL SOURCES OF CONTAMINATION

<b>Potential Source</b>	Oil, grease, fuel and hydraulic fluid contamination from construction equipment and vehicle dripping.
Preventive Measure	Vehicle maintenance, when possible, will be performed within a construction staging area specified by the General Contractor.
<b>Potential Source</b>	Miscellaneous trash and litter from construction workers and material wrappings.
Preventive Measure	Trash containers will be placed throughout the site to encourage proper trash disposal.
<b>Potential Source</b>	Construction debris.
Preventive Measure	Construction debris will be monitored daily by contractor. Debris will be collected weekly and placed in disposal bins. Situations requiring immediate attention will be addressed on a case by case basis.
<b>Potential Source</b>	Stormwater contamination from excess application of fertilizers, herbicides and pesticides.
Preventive Measure	Fertilizers, herbicides and pesticides will be applied only when necessary and in accordance with manufacturers' directions.
<b>Potential Source</b>	Soil and mud from construction vehicle tires as they leave the site.
Preventive Measure	A temporary construction entrance/exit shall be utilized as vehicles leave the site. Any soil, mud, etc. carried from the project onto public roads shall be cleaned up within 24 hours.
<b>Potential Source</b>	Sediment from soil, sand, gravel and excavated materials stockpiled on site.
Preventive Measure	Silt fence shall be installed on the down gradient side of all stockpiled materials. Reinforced rock berms shall be installed at all downstream discharge locations.
<b>Potential Source</b>	Portable toilet spill
Preventive Measure	Toilets on the site will be emptied on a regular basis by the contracted toilet company.



### ATTACHMENT C – SEQUENCE OF MAJOR ACTIVITIES

Sequence Item	Description	Approximate Acres Disturbed
1.	Site Grading for Infrastructure Improvements	<b>46.55</b>
2.	Construction of Sanitary Sewer and Water Lines	<b>6.67</b>

*Temporary control measures used for each major activity listed above should include construction entrances/exits, concrete washout areas, silt fence, rock berms, bagged gravel inlet filters and temporary seeding. More information on these temporary best management practices can be found on the next page (Attachment D)*

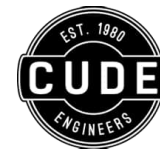

## ATTACHMENT D – TEMPORARY BEST MANAGEMENT PRACTICES AND MEASURES

The TBMPs and measures utilized for the proposed project to prevent pollution of storm water, groundwater, and surface water during the construction phase are the following:

1. Temporary Construction Entrance/Exit – A stabilized pad of crushed stone located at any point where traffic will be entering or leaving the construction site from a public R.O.W., street, alley, sidewalk or parking area. It shall be a minimum of 50 feet long, 12 feet wide and 8 inches thick. The rock shall be 4 to 8 inches in size.
2. Concrete Washout Areas- A pit containment area with a 10 mil plastic lining with a berm and sand bags to prevent or reduce the discharge of pollutants from concrete waste shall be constructed in an area readily accessible to construction traffic and at least 50 ft. away from any sensitive features, storm drains, open ditches or water bodies.
3. Silt Fence – A barrier consisting of geotextile fabric supported by metal posts to prevent soil and sediment loss from a site. Silt fences shall be installed on the down gradient side of the proposed areas to be disturbed that have a drainage area of 2 or less acres.
4. Rock Berms – A structure of 3 to 5 inch diameter rock secured with a woven wire sheath to serve as a check dam in areas of concentrated flow, to intercept sediment-laden runoff, detain the sediment and release the water in sheet flow.
5. Bagged Gravel Inlet Filter – Sandbags filled with washed pea gravel and stacked to form a continuous barrier about 1 foot high around the inlets.
6. Temporary Seeding – Temporary seeding of disturbed areas shall be performed if disturbed areas are expected to have no construction activity for a period of at least 21 days

### Sequence of installation during construction process

1. The Temporary Construction Entrance/Exit shall be installed prior to disturbing any soil except at the location of the Temporary Construction Entrance/Exit. It shall stay in place and be maintained until the end of the infrastructure construction.
2. Silt Fence will be installed along the down gradient side of the proposed site prior to disturbing any soil. It shall stay in place and be maintained until the site has been properly re-vegetated.
3. Rock Berms – Rock berms shall be installed around the perimeter of the project at natural low points following rough grading of the site and shall be removed once grading to the on-site stormwater drainage system with bagged gravel inlet filters in sump is complete. Rock berms will also be utilized at the outlet of the pond while it is being constructed.
4. Concrete washout pits shall be installed prior to any concrete work to be done on site. It shall remain on site until all concrete work has been completed and hardened concrete shall be broken up, removed and disposed of properly. Materials for the pit shall be removed from the site and also be disposed of properly. Any depressions or ground disturbance due to removal of pit area shall be backfilled and repaired.
5. Bagged Gravel Inlet Filters shall be placed around all inlets following installation.
6. Temporary Seeding shall be installed in areas which are considered as final grades and area will not

be covered by pavements, building or other structures. Seeding shall also be done in graded areas where there is a potential for erosion on steep slopes.

Upgradient Surface water, Groundwater and Stormwater

There is no surface water or ground water originating from the site. There is approximately 0.00 acres of up-gradient stormwater that will drain to the site. Stormwater coming from the north gets intercepted by the floodplain before it gets to the part of the site that will be developed.

Onsite Surface water, Groundwater and Stormwater

Temporary BMPs utilized on the proposed project site to prevent pollution of onsite surface water, groundwater, and storm water are the silt fences acting as barriers to prevent pollution of stormwater.

Prevention of Pollutants Entering Surface Streams, Sensitive Features and the Aquifer

Temporary BMPs utilized on the proposed project site to prevent pollution of surface streams, sensitive features, and the aquifer are temporary construction entrance/exit, silt fences, and rock berms. The construction entrance/exit provides a stable exit from the construction site and keeps sediment and mud off public roads. The other TBMPs delineated act in like manner as previously described to protect surface streams, sensitive features, and the aquifer.

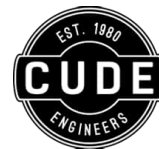

## ATTACHMENT E – REQUEST TO TEMPORARILY SEAL A FEATURE

Not applicable to this project



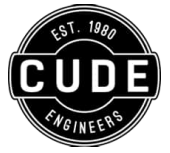

## ATTACHMENT F – STRUCTURAL PRACTICES

Runoff discharge of pollutants from exposed areas of the site will be limited through the utilization of temporary BMPs. Prior to leaving the site, flows containing pollutant discharges will be treated by a silt fence, bagged gravel inlet filters, or rock berms which will limit the amount of pollutants leaving the site. These temporary BMPs will be placed in the natural lows that discharge from the site. They will be placed in flows low enough to keep the temporary BMP intact throughout construction.

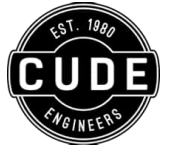

## ATTACHMENT G – DRAINAGE AREA MAP

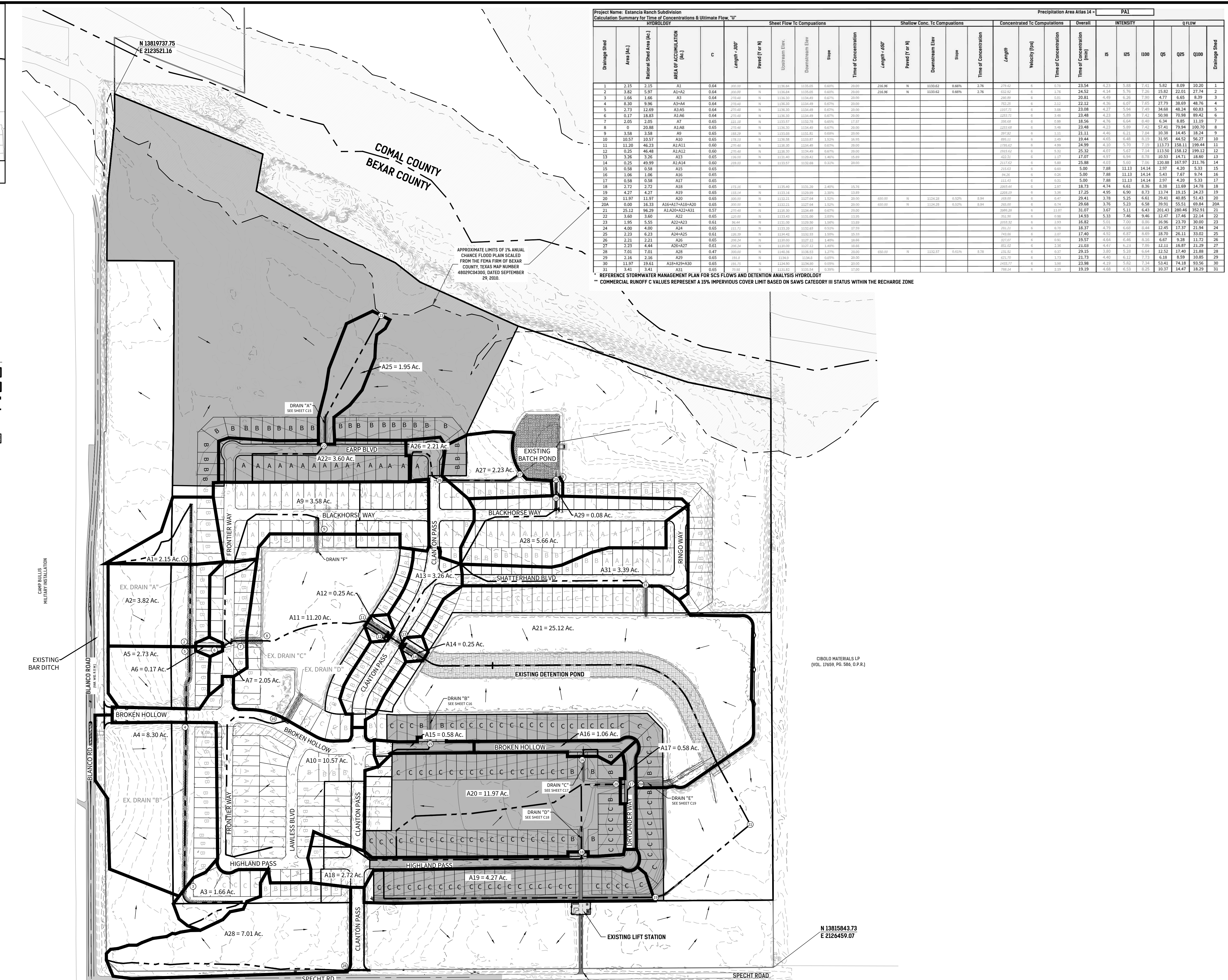
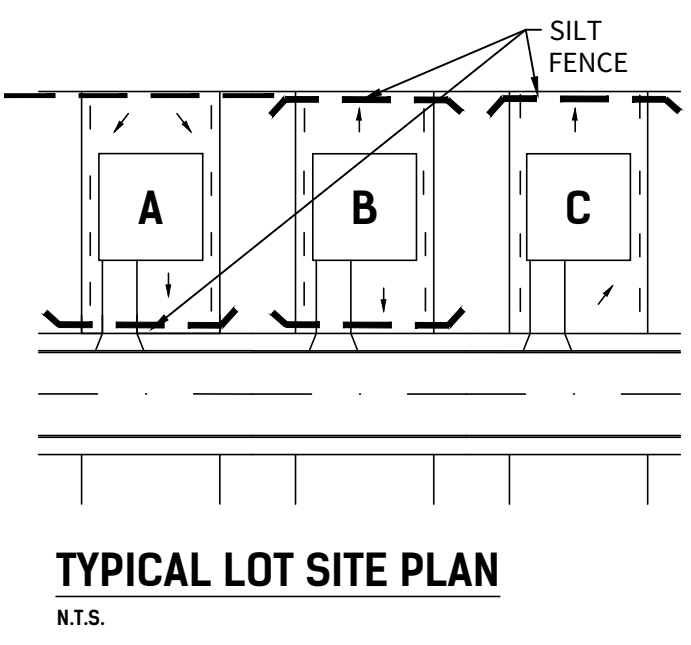
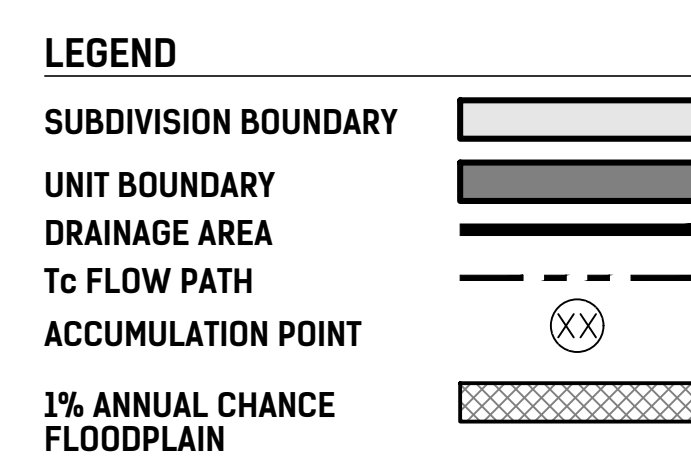
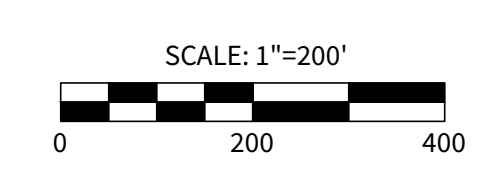
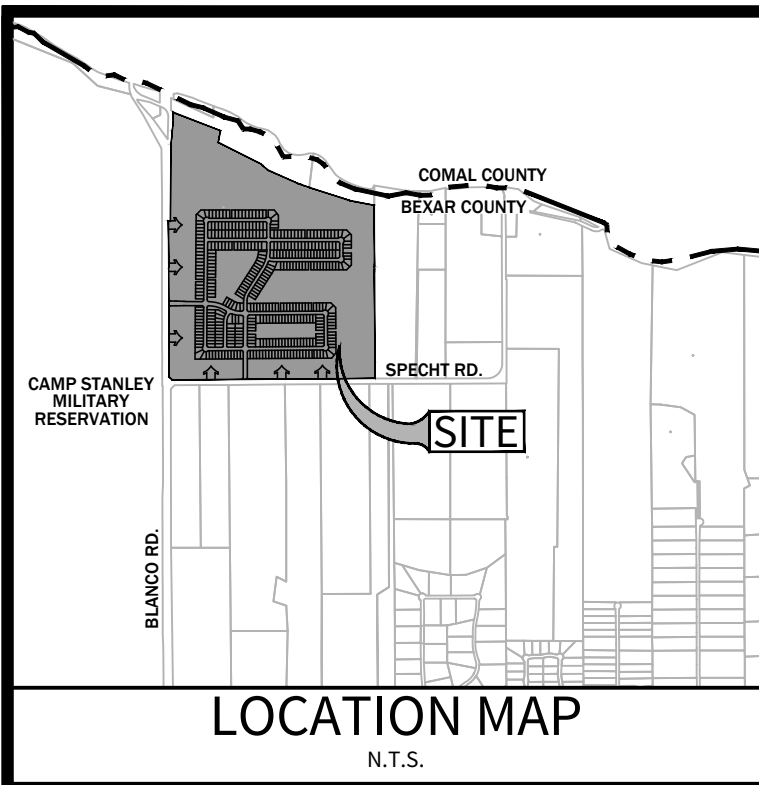

Project Name: Estancia Ranch Subdivision  
 Calculation Summary for Time of Concentration & Ultimate Flow, "U"

HYDROLOGY										Sheet Flow Tc Computations				Shallow Conc. Tc Computations				Concentrated Tc Computations		Overall		INTENSITY		q flow		
Drainage Shed	Area (Ac.)	Rational Shed Area (Ac.)	AREA OF ACCUMULATION (Ac.)	C	Length, 80'	Paved (Y or N)	Upstream Elev.	Downstream Elev.	Slope	Time of Concentration	Length, 60'	Paved (Y or N)	Downstream Elev.	Slope	Time of Concentration	Length	Velocity (ft/s)	Time of Concentration	Time of Concentration (min)	I5	I25	I100	Q5	Q25	Q100	Drainage Shed
1	2.15	2.15	A1	0.64	300.00	N	1136.84	1135.25	0.005	20.00	216.96	N	1133.62	0.66%	2.76	279.42	0	0.75	23.54	4.23	5.88	7.41	5.82	8.09	10.20	1
2	3.82	5.97	A1+A2	0.64	300.00	N	1136.84	1135.00	0.005	20.00	216.96	N	1133.62	0.66%	2.76	279.42	0	0.75	23.54	4.23	5.88	7.41	5.82	8.09	10.20	2
3	1.66	1.66	A3	0.64	270.48	N	1136.84	1134.40	0.007	20.00	200.00	N	1133.62	0.66%	2.76	279.42	0	0.75	23.54	4.23	5.88	7.41	5.82	8.09	10.20	3
4	8.30	8.30	A3+A4	0.64	270.48	N	1136.84	1134.40	0.007	20.00	200.00	N	1133.62	0.66%	2.76	279.42	0	0.75	23.54	4.23	5.88	7.41	5.82	8.09	10.20	4
5	2.73	12.69	A3+A5	0.64	270.48	N	1136.84	1134.40	0.007	20.00	200.00	N	1133.62	0.66%	2.76	279.42	0	0.75	23.54	4.23	5.88	7.41	5.82	8.09	10.20	5
6	0.17	18.83	A1+A6	0.64	270.48	N	1136.84	1134.40	0.007	20.00	200.00	N	1133.62	0.66%	2.76	279.42	0	0.75	23.54	4.23	5.88	7.41	5.82	8.09	10.20	6
7	2.05	2.05	A7	0.65	222.00	N	1133.62	1132.70	0.008	12.87	100.00	N	1133.62	0.66%	2.76	279.42	0	0.75	23.54	4.23	5.88	7.41	5.82	8.09	10.20	7
8	0	20.88	A1+A8	0.65	270.48	N	1136.84	1134.40	0.007	20.00	200.00	N	1133.62	0.66%	2.76	279.42	0	0.75	23.54	4.23	5.88	7.41	5.82	8.09	10.20	8
9	3.58	3.58	A9	0.65	188.20	N	1133.62	1131.81	0.009	20.00	100.00	N	1133.62	0.66%	2.76	279.42	0	0.75	23.54	4.23	5.88	7.41	5.82	8.09	10.20	9
10	10.57	10.57	A10	0.65	198.12	N	1136.84	1130.87	0.009	20.00	100.00	N	1133.62	0.66%	2.76	279.42	0	0.75	23.54	4.23	5.88	7.41	5.82	8.09	10.20	10
11	11.20	46.23	A1+A11	0.60	270.48	N	1136.84	1134.40	0.007	20.00	200.00	N	1133.62	0.66%	2.76	279.42	0	0.75	23.54	4.23	5.88	7.41	5.82	8.09	10.20	11
12	0.25	46.48	A1+A12	0.60	270.48	N	1136.84	1134.40	0.007	20.00	200.00	N	1133.62	0.66%	2.76	279.42	0	0.75	23.54	4.23	5.88	7.41	5.82	8.09	10.20	12
13	3.26	3.26	A13	0.65	180.00	N	1131.40	1129.42	0.009	15.00	100.00	N	1133.62	0.66%	2.76	279.42	0	0.75	23.54	4.23	5.88	7.41	5.82	8.09	10.20	13
14	0.25	49.89	A1+A14	0.60	200.00	N	1133.62	1133.60	0.000	20.00	200.00	N	1133.62	0.66%	2.76	279.42	0	0.75	23.54	4.23	5.88	7.41	5.82	8.09	10.20	14
15	0.58	0.58	A15	0.65	100.00	N	1133.62	1133.60	0.000	20.00	100.00	N	1133.62	0.66%	2.76	279.42	0	0.75	23.54	4.23	5.88	7.41	5.82	8.09	10.20	15
16	1.06	1.06	A16	0.65	100.00	N	1133.62	1133.60	0.000	20.00	100.00	N	1133.62	0.66%	2.76	279.42	0	0.75	23.54	4.23	5.88	7.41	5.82	8.09	10.20	16
17	0.58	0.58	A17	0.65	100.00	N	1133.62	1133.60	0.000	20.00	100.00	N	1133.62	0.66%	2.76	279.42	0	0.75	23.54	4.23	5.88	7.41	5.82	8.09	10.20	17
18	2.72	2.72	A18	0.65	175.20	N	1135.40	1133.20	0.009	15.16	100.00	N	1133.62	0.66%	2.76	279.42	0	0.75	23.54	4.23	5.88	7.41	5.82	8.09	10.20	18
19	4.27	4.27	A19	0.65	188.14	N	1133.16	1130.20	0.009	13.89	100.00	N	1133.62	0.66%	2.76	279.42	0	0.75	23.54	4.23	5.88	7.41	5.82	8.09	10.20	19
20	11.97	11.97	A20	0.65	200.00	N	1133.62	1127.04	0.009	20.00	100.00	N	1133.62	0.66%	2.76	279.42	0	0.75	23.54	4.23	5.88	7.41	5.82	8.09	10.20	20
20A	0.00	16.33	A16+A17+A18+A20	0.65	300.00	N	1133.62	1127.04	0.009	20.00	100.00	N	1133.62	0.66%	2.76	279.42	0	0.75	23.54	4.23	5.88	7.41	5.82	8.09	10.20	20A
21	25.12	96.29	A1+A20+A21+A31	0.57	270.48	N	1136.84	1134.40	0.007	20.00	200.00	N	1133.62	0.66%	2.76	279.42	0	0.75	23.54	4.23	5.88	7.41	5.82	8.09	10.20	21
22	3.60	3.60	A22	0.65	200.00	N	1133.62	1133.60	0.000	12.95	100.00	N	1133.62	0.66%	2.76	279.42	0	0.75	23.54	4.23	5.88	7.41	5.82	8.09	10.20	22
23	1.95	5.55	A23+A23	0.61	86.84	N	1133.62	1133.60	0.000	12.88	100.00	N	1133.62	0.66%	2.76	279.42	0	0.75	23.54	4.23	5.88	7.41	5.82	8.09	10.20	23
24	4.00	4.00	A24	0.65	112.71	N	1133.62	1132.63	0.009	17.99	100.00	N	1133.62	0.66%	2.76	279.42	0	0.75	23.54	4.23	5.88	7.41	5.82	8.09	10.20	24
25	2.23	6.23	A24+A25	0.61	180.30	N	1134.42	1132.51	0.009	15.31	100.00	N	1133.62	0.66%	2.76	279.42	0	0.75	23.54	4.23	5.88	7.41	5.82	8.09	10.20	25
26	2.21	2.21	A26	0.65	200.00	N	1133.62	1133.60	0.000	14.86	100.00	N	1133.62	0.66%	2.76	279.42	0	0.75	23.54	4.23	5.88	7.41	5.82	8.09	10.20	26
27	2.23	4.44	A26+A27	0.61	200.24	N	1133.62	1132.11	0.009	18.64	100.00	N	1133.62	0.66%	2.76	279.42	0	0.75	23.54	4.23	5.88	7.41	5.82	8.09	10.20	27
28	7.01	7.01	A28	0.47	300.00	N	1140.58	1138.59	0.007	20.00	100.00	N	1133.62	0.66%	2.76	279.42	0	0.75	23.54	4.23	5.88	7.41	5.82	8.09	10.20	28
29	2.16	2.16	A29	0.65	180.00	N	1134.70	1134.00	0.006	20.00	100.00	N	1133.62	0.66%	2.76	279.42	0	0.75	23.54	4.23	5.88	7.41	5.82	8.09	10.20	29
30	11.97	18.61	A18+A29+A30	0.65	180.25	N	1134.50	1134.00	0.006	20.00	100.00	N	1133.62	0.66%	2.76	279.42	0	0.75	23.54	4.23	5.88	7.41	5.82	8.09	10.20	30
31	3.41	3.41	A31	0.65	78.98	N	1133.62	1131.64	0.009	17.00	100.00	N	1133.62	0.66%	2.76	279.42	0	0.75	23.54	4.23	5.88	7.41	5.82	8.09	10.20	31

REFERENCE STORMWATER MANAGEMENT PLAN FOR SCS FLOWS AND DETENTION ANALYSIS HYDROLOGY  
 \*\* COMMERCIAL RUNOFF C VALUES REPRESENT A 15% IMPERVIOUS COVER LIMIT BASED ON SAWS CATEGORY III STATUS WITHIN THE RECHARGE ZONE

APPROXIMATE LIMITS OF 1% ANNUAL CHANCE FLOOD PLAIN SCALED FROM THE FEMA FIRM OF BEJAR COUNTY, TEXAS MAP NUMBER 4809PC0403, DATED SEPTEMBER 29, 2010.

CIBOLO MATERIALS LP (VOL. 17659, PG. 586, O.P.R.)

N 13815843.73 E 2126459.07

KLABUNDE KORY WAYNE  
 KLABUNDE KRISTOPHER MICHAEL (VOL. 14470, PG. 0439, O.P.R.)  
 LAMBRECHT WILLIAM E  
 KLABUNDE DOUGLAS L (VOL. 14470, PG. 0433, O.P.R.)  
 SCHOLZ RENE A L/E  
 WELBORN LAYRNE RAHE (VOL. 5678, PG. 126, O.P.R.)  
 MCDANIEL CHARLES E  
 WELBORN LAYRNE RAHE & PATRICK E  
 VOL. 5301, PG. 150R, O.P.R.

REPRODUCTION OF THE ORIGINAL SIGNED AND SEALED PLAN AND/OR ELECTRONIC MEDIA MAY HAVE BEEN INADVERTENTLY ALTERED. CONTRACTOR IS RESPONSIBLE FOR VERIFYING THE SCALE OF THE DOCUMENT AND CONTACTING CUDE ENGINEERS TO VERIFY DISCREPANCIES PRIOR TO CONSTRUCTION.

© 2022 M.W. CUDE ENGINEERS, LLC. THIS DOCUMENT, ANY PORTION THEREOF, AND ANY ASSOCIATED COPYRIGHTS SHALL REMAIN THE PROPERTY OF M.W. CUDE ENGINEERS, LLC. THIS DOCUMENT MAY NOT BE REPRODUCED, USED, OR DISTRIBUTED IN ANY FORM OR BY ANY MEANS TO ANYONE FOR ANY OTHER ENDORSEMENT WITHOUT THE PRIOR WRITTEN CONSENT OF M.W. CUDE ENGINEERS, LLC. THIS DOCUMENT IS NOT INTENDED OR REPRESENTED TO BE SUITABLE FOR USE OTHER THAN AS ORIGINALLY INTENDED BY M.W. CUDE ENGINEERS, LLC AND ANY UNAUTHORIZED REPRODUCTION, USE OR DISTRIBUTION OF SAID DOCUMENTS WILL BE AT THE INFRINGING PARTY'S SOLE RISK, WITHOUT ANY LIABILITY TO M.W. CUDE ENGINEERS, LLC, AND WILL BE USED AGAINST ANY AND ALL PARTIES TO THE FULLEST EXTENT PERMITTED BY LAW.

CUDEENGINEERS.COM

4122 Pond Hill Road, Suite 101  
 San Antonio, Texas 78231  
 P: (210) 681.2951 F: (210) 523.7112

ESTANCIA RANCH SUBDIVISION  
 UNIT 3  
 OVERALL MASTER DRAINAGE PLAN

DATE: 10/26/2023  
 PROJECT NO.: 03473.010  
 DRAWN BY: CG/TC/XV  
 CHECKED BY: XV/AL

REVISIONS

DATE

10/26/2023  
 CUDE ENGINEERS  
 TBPE No. 455  
 TBPLS No. 10048500

PLAT NO.  
 23-11800329

C2

CUDEENGINEERS.COM

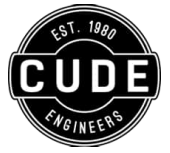

## ATTACHMENT H – TEMPORARY SEDIMENT POND PLANS AND CALCULATIONS

Not applicable to this project

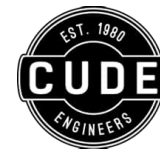

## ATTACHMENT I – INSPECTION AND MAINTENANCE FOR BMPS

### Temporary Sediment Control Fences

1. Inspect all fencing weekly, and after any rainfall.
2. Remove sediment when buildup reaches 6 inches.
3. Replace any torn fabric or install a second line of fencing parallel to the torn section.
4. Replace or repair any sections crushed or collapsed in the course of construction activity. If a section of fence is obstructing vehicular access, consider relocating it to a spot where it will provide equal protection, but will not obstruct vehicles. A triangular filter dike may be preferable to a silt fence at common vehicle access points.
5. When construction is complete, the sediment should be disposed of in a manner that will not cause additional siltation and the prior location of silt fence should be re-vegetated. The fence itself should be disposed of in an approved landfill.

### Rock Berm / High Service Rock Berm

1. Inspections should be made weekly and after each rainfall by the responsible party.
2. Remove sediment and other debris when buildup reaches 6 inches and dispose of the accumulated silt of in an approved manner.
3. Repair any loose wire sheathing.
4. The berm should be reshaped as needed during inspection.
5. The berm should be replaced when the structure ceases to function as intended due to silt accumulation among the rocks, washout, construction traffic damage, etc.
6. The rock berm should be left in place until all upstream areas are stabilized and accumulated silt removed.

### Temporary Construction Entrance and Exits

1. The entrance should be maintained in a condition, which will prevent tracking or following of sediment onto public rights-of-way. This may require periodic top dressing with additional stone as conditions demand and repair and/or cleanout of any measures used to trap sediment.
2. All sediment spilled, dropped, washed or tracked on to public rights-of-ways should be removed immediately by contractor.
3. When necessary, wheels should be cleaned to remove sediment prior to entrance onto public right-of-way.
4. When washing is required, it should be done on an area stabilized with crushed stone that drains into an approved sediment trap or sediment basin.
5. All sediment should be prevented from entering ant storm drain, ditch, or water course by using approved methods.

### Bagged Gravel Inlet Filters

1. Inspections should be made weekly and after each rainfall. Repair or replacement should be made promptly as needed by the contractor.
2. Remove sediment when buildup reaches a depth of 3 inches. Removed sediment should be deposited

in a suitable area and in such a manner that it will not erode.

3. Check placement of device to prevent gaps between device and curb.
4. Inspect filter fabric and patch or replace if missing or torn,
5. Structures should be removed and the area stabilized only after the remaining drainage area has been properly stabilized.

#### Temporary Seeding

1. Temporary vegetation should be inspected weekly and after each rain event to locate and repair any erosion.
2. Erosion from storms or other damage should be repaired as soon as practical by regarding the area and applying new seed.
3. If the vegetated cover is less than 80%, the area should be reseeded.

#### Concrete Washout Pit Area

1. Each material making up pit area shall be inspected for any damage.
2. Plastic lining shall be inspected periodically to ensure no holes, tears or other defects are observed that might compromise the impermeability of the material.
3. Remove accumulated hardened concrete by breaking up and disposing of properly and if necessary, replacing plastic lining.

#### Documentation Procedures

1. A copy of the inspection report is located on the following page.
2. The inspection report must be maintained on site at all times.
3. The inspection report is incorporated as part of the WPAP. The contractor is responsible for completing and updating the form in compliance with TCEQ rules.

#### Inspections

Designated and qualified person(s) shall inspect Pollution Control Measures every fourteen days and within 24 hours after a storm event greater than 0.5 inches of rainfall. An inspection report that summarizes the scope of the inspection, names and qualifications of personnel conducting the inspection, date of the inspection, major observations, and actions taken as a result of the inspection shall be recorded and maintained as part of Storm Water TPDES data for a period of three years after the date of the inspection. A copy of the Inspection Report Form is provided in this Storm Water Pollution Prevention Plan.

As a minimum, the inspector shall observe: (1) significant disturbed areas for evidence of erosion, (2) storage areas for evidence of leakage from the exposed stored materials, (3) structural controls (rock berm outlets, silt fences, drainage swales, etc.) for evidence of failure or excess siltation (over 6 inches deep), (4) vehicle exit point for evidence of off-site sediment tracking, (5) vehicle storage areas for signs of leaking equipment or spills, and (6) concrete truck rinse-out pit for signs of potential failure. Deficiencies noted during the inspection will be corrected and documented within seven (7) calendar days following the inspection or before the next anticipated storm event if practicable.

### BMP INSPECTION REPORT

Pollution Prevention Measure	Inspected	Corrective Action	
		Description	Date Completed
Silt Fence	Inspections		
	Fencing		
	Sediment Removal		
	Torn Fabric		
	Crushed/Collapsed Fencing		
Construction Entrance/Exit	Inspections		
	Additional top Dressing		
	Repair/Cleanout		
	Sediment removed immediately		
Rock Berm	Inspections		
	Fencing		
	Sediment Removal		
	Torn Fabric		
	Crushed/Collapsed Fencing		
Bagged Gravel Inlet Filter	Inspections		
	Sediment Removal		
	Device Placement		
	Torn Fabric		
Temporary Seeding	Inspections		
	Eroded Areas		
	Vegetated cover less than 80%		
Concrete Washout Pit	Inspections		
	Plastic Lining		
	Berm / sand bags		
	Accumulated concrete/removal		

*\*Indicate N/A where measure does not apply.*

By my signature below, I certify that all items are acceptable and the project site is in compliance with SWPPP.

\_\_\_\_\_  
Inspector's Name

\_\_\_\_\_  
Inspector's Signature

\_\_\_\_\_  
Name of Owner/Operator (Firm)

\_\_\_\_\_  
Date

**Note: Inspector is to attach a brief statement of his qualifications to this report.**

### BMP INSPECTION REPORT

Pollution Prevention Measure	Inspected	Corrective Action	
		Description	Date Completed
<b>General</b>			
Revegetation			
Erosion/Sediment Controls			
Vehicle Exits			
Material Areas			
Equipment Areas			
Concrete Rinse			
Construction Debris			
Trash Receptacles			
<b>Infrastructure</b>			
Roadway Clearing			
Utility Clearing			
Roadway Grading			
Utility Construction			
Drainage Construction			
Roadway Base			
Roadway Surfaces			
Site Cleanups			
<b>Building</b>			
Clearing for Building			
Foundation Grading			
Utility Construction			
Foundation Construction			
Building Construction			
Site Grading			
Site Cleanup			

*\*Indicate N/A where measure does not apply.*

By my signature below, I certify that all items are acceptable and the project site is in compliance with SWPPP.

\_\_\_\_\_  
Inspector's Name

\_\_\_\_\_  
Inspector's Signature

\_\_\_\_\_

\_\_\_\_\_



Name of Owner/Operator (Firm)

Date

*Note: Inspector is to attach a brief statement of his qualifications to this report.*

## BMP INSPECTION REPORT PROJECT CONSTRUCTION ACTIVITY MILESTONE DATES

Date when major site grading activities begin:

Construction Activity

Date

_____	_____
_____	_____
_____	_____
_____	_____
_____	_____
_____	_____
_____	_____

Dates when construction activities temporarily or permanently cease on all or a portion of the project:

Construction Activity

Date

_____	_____
_____	_____
_____	_____
_____	_____
_____	_____
_____	_____

Date when stabilization measures are initiated:

Stabilization Activity

Date

_____	_____
_____	_____
_____	_____

---

---

---

---

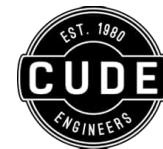

## ATTACHMENT J – SCHEDULE OF INTERIM AND PERMANENT SOIL STABILIZATION PRACTICES

1. Stabilization measures shall be initiated as soon as practicable in portions of the site where construction activities have temporarily or permanently ceased, but in no case more than 14 days after the construction activity in that portion of the site has temporarily or permanently ceased. Where the initiation of stabilization measures by the 14<sup>th</sup> day after construction activity temporarily or permanently cease is precluded by weather conditions, stabilization measures shall be initiated as soon as practicable. Where construction activity on a portion of the site is temporarily ceased, and earth disturbing activities will be resumed within 21 days, temporary stabilization measures do not have to be initiated on that portion of site. In areas experiencing droughts where the initiation of stabilization measures by the 14<sup>th</sup> day after construction activity has temporarily or permanently ceased is precluded by seasonal arid conditions, stabilization measures shall be initiated as soon as practicable.
2. Permanent seeding of individually disturbed areas shall be performed when infrastructure construction has been completed.
3. Permanent sodding and mulching of landscape areas shall occur at or near the completion of the project.
4. During construction, contractors shall, to the maximum extent possible, limit their construction activities to areas of construction as noted on the plans in an attempt to preserve as much natural vegetation as possible.

### Seeding & Mulching Specifications

1. All seed must meet requirements of the Texas Seed Law including the labeling requirements. These labels shall show purity, germination, name and type of seed. Seed furnished shall be of the previous season's crop for the date of the project, and the date of analysis shown on each bag shall be within nine (9) months of the time of use on the project. Bermuda grass shall be hulled and treated and have a purity of 95% and germination of no less than 90%. Each variety of seed shall be furnished and delivered in separate bags or containers. A sample of each variety of seed shall be furnished for analysis and testing when directed by the Owner.
2. Annual Rye grass will be free of Johnson grass, field bindweed, dodder seed, and free of other seed to the limits allowable under the Federal Seed Act and applicable Texas Seed Law. Annual Rye grass will be added into slurry between October 1 through March 15.
3. Wood Cellulose Fiber Mulch. Wood cellulose fiber mulch shall be natural cellulose fiber mulch produced from grinding clean, whole wood chips, or fiber produced from ground newsprint with a labeled ash content not to exceed 7%. The mulch shall be designed for use in conventional mechanical planting, hydraulic planting of seed or hydraulic mulching of grass seed, either alone or with fertilizer and

other additives. The mulch shall be that when applied, the material shall form a strong, moisture-retaining mat without the need of an asphalt binder. The mulch material will also be dyed with a green color to assist in determining coverage and to provide an immediate pleasing appearance. The wood cellulose fiber is also required to be dispersed rapidly in water to form homogeneous slurry and remain in such state when agitated in the hydraulic mulching unit with specified materials.

4. Straw Mulch or Hay Mulch. Straw mulch shall be oat, wheat, or rice straw. Hay mulch shall be prairie grass, Bermuda grass or other hay as approved by the Owner. The straw mulch or hay mulch shall be free of Johnson grass or other noxious weeds and foreign materials. It shall be kept in a dry condition and shall not be molded or rotted.

Optimum Planting Dates	Common Names	Rate, lbs./acre
February 1 – May 1	Bermuda Grass	1.5
September 1 – November 30	Tall Fescue	4.0
	Oats	21.0*
	Wheat (Red, Winter)	30.0
September 1 – November 30	Hairy Vetch	8.0
May 1 – August 31	Foxtail Millet	30.0

### 1.3.10 Hydraulic Mulch

Hydraulic mulch consists of applying a mixture of shredded wood fiber or a hydraulic matrix, and a stabilizing emulsion or tackifier with hydro-mulching equipment, which temporarily protects exposed soil from erosion by raindrop impact or wind. Hydraulic mulch is suitable for soil disturbed areas requiring temporary protection until permanent stabilization is established, and disturbed areas that will be re-disturbed following an extended period of inactivity. It is not appropriate for slopes of 3:1 or steeper or for use in channels.

Wood fiber hydraulic mulches are generally short lived and need 24 hours to dry before rainfall occurs to be effective. May require a second application in order to remain effective for an entire rainy season.

#### **Materials:**

*Hydraulic Mulches:* Wood fiber mulch can be applied alone or as a component of hydraulic matrices. Wood fiber applied alone is typically applied at the rate of 2,000 to 4,000 lb/acre. Wood fiber mulch is manufactured from wood or wood waste from lumber mills or from urban sources.

*Hydraulic Matrices:* Hydraulic matrices include a mixture of wood fiber and acrylic polymer or other tackifier as binder. Apply as a liquid slurry using a hydraulic application machine (i.e., hydro seeder) at the following minimum rates, or as specified by the manufacturer to achieve complete coverage of the target area: 2,000 to 4,000 lb/acre wood fiber mulch, and 5 to 10% (by weight) of tackifier (acrylic copolymer, guar, psyllium, etc.)

*Bonded Fiber Matrix:* Bonded fiber matrix (BFM) is a hydraulically applied system of fibers and adhesives that upon drying forms an erosion resistant blanket that promotes vegetation, and prevents soil erosion. BFMs are typically applied at rates from 3,000 lb/acre to 4,000 lb/acre based on the manufacturer's recommendation. A biodegradable BFM is composed of materials that are 100% biodegradable. The binder in the BFM should also be biodegradable and should not dissolve or disperse upon re-wetting. Typically, biodegradable BFMs should not be applied immediately before, during or immediately after rainfall if the soil is saturated. Depending on the product, BFMs typically require 12 to 24 hours to dry and become effective.

### **Installation:**

- (1) Prior to application, roughen embankment and fill areas by rolling with a crimping or punching type roller or by track walking. Track walking shall only be used where other methods are impractical.
- (2) To be effective, hydraulic matrices require 24 hours to dry before rainfall occurs.
- (3) Avoid mulch over spray onto roads, sidewalks, drainage channels, existing vegetation, etc.

### **Inspection and Maintenance Guidelines:**

- (1) Mulched areas should be inspected weekly and after each rain event to locate and repair any damage.
- (2) Areas damaged by storms or normal construction activities should be regraded and hydraulic mulch reapplied as soon as practical.

#### **1.3.11 Sod**

Sod is appropriate for disturbed areas which require immediate vegetative covers, or where sodding is preferred to other means of grass establishment. Locations particularly suited to stabilization with sod are waterways carrying intermittent flow, areas around drop inlets or in grassed swales, and residential or commercial lawns where quick use or aesthetics are factors.

The advantages of properly installed sod include:

- Immediate erosion control.
- An instant green surface with no dust or mud.
- Nearly year-round establishment capability.
- Less chance of failure than seed.
- Freedom from weeds.
- Quick use of the sodded surface.
- The option of buying a quality-controlled product with predictable results.

It is initially more costly to install sod than to seed. However, this cost is justified in places where sod can perform better than seed in controlling erosion. In swales and waterways where concentrated flow will occur, properly pegged sod is preferable to seed because there is no lag time between installation and the time when the channel is protected by vegetation. Drop inlets, which will be placed in grassed areas, can be kept

free of sediment, and the grade immediately around the inlet can be maintained, by framing the inlet with sod strips.

Sod can be laid during times of the year when seeded grass may fail, so long as there is adequate water available for irrigation in the early weeks. Ground preparation and proper maintenance are as important with sod as with seed. Sod is composed of living plants and those plants must receive adequate care in order to provide vegetative stabilization on a disturbed area.

#### **Materials:**

- (1) Sod should be machine cut at a uniform soil thickness of  $\frac{3}{4}$  inch ( $\pm \frac{1}{4}$  inch) at the time of cutting. This thickness should exclude shoot growth and thatch.
- (2) Pieces of sod should be cut to the supplier's standard width and length, with a maximum allowable deviation in any dimension of 5%. Torn or uneven pads should not be acceptable.
- (3) Standard size sections of sod should be strong enough to support their own weight and retain their size and shape when suspended from a firm grasp on one end of the section.
- (4) Sod should be harvested, delivered, and installed within a period of 36 hours.

#### **Site Preparation:**

- (1) Prior to soil preparation, areas to be sodded should be brought to final grade in accordance with the approved plan.
- (2) The surface should be cleared of all trash, debris and of all roots, brush, wire, grade stakes and other objects that would interfere with planting, fertilizing or maintenance operations.
- (3) Fertilize according to soil tests. Fertilizer needs can be determined by a soil testing laboratory or regional recommendations can be made by county agricultural extension agents. Fertilizer should be worked into the soil to a depth of 3 inches with a disc, springtooth harrow or other suitable equipment. On sloping land, the final harrowing or discing operation should be on the contour.

**General Installation (VA Dept of Conservation, 1992):**

- (1) Sod should not be cut or laid in excessively wet or dry weather. Sod also should not be laid on soil surfaces that are frozen.
- (2) During periods of high temperature, the soil should be lightly irrigated immediately prior to laying the sod, to cool the soil and reduce root burning and dieback.
- (3) The first row of sod should be laid in a straight line with subsequent rows placed parallel to and butting tightly against each other. Lateral joints should be staggered to promote more uniform growth and strength. Care should be exercised to ensure that sod is not stretched or overlapped and that all joints are butted tight in order to prevent voids which would cause drying of the roots (see Figure 1-22).
- (4) On slopes 3:1 or greater, or wherever erosion may be a problem, sod should be laid with staggered joints and secured by stapling or other approved methods. Sod should be installed with the length perpendicular to the slope (on the contour).
- (5) As sodding of clearly defined areas is completed, sod should be rolled or tamped to provide firm contact between roots and soil.
- (6) After rolling, sod should be irrigated to a depth sufficient that the underside of the sod pad and the soil 4 inches below the sod is thoroughly wet.
- (7) Until such time a good root system becomes developed, in the absence of adequate rainfall, watering should be performed as often as necessary to maintain moist soil to a depth of at least 4 inches.
- (8) The first mowing should not be attempted until the sod is firmly rooted, usually 2-3 weeks. Not more than one third of the grass leaf should be removed at any one cutting.



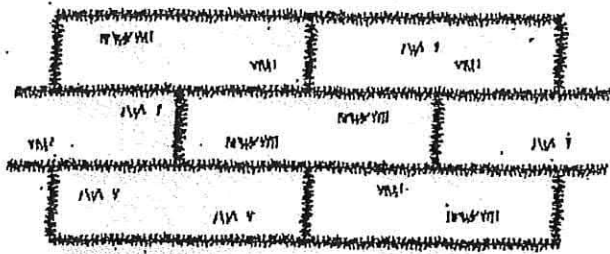

LAY SOD IN A STAGGERED PATTERN, BUTT THE STRIPS TIGHTLY AGAINST EACH OTHER, DO NOT LEAVE SPACES AND DO NOT OVERLAP. A SHARPENED MASON'S TROWEL IS A HANDY TOOL FOR TUCKING DOWN THE ENDS AND TRIMMING PIECES.

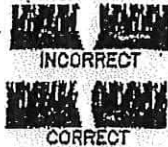

BUTTING - ANGLED ENDS CAUSED BY THE AUTO-MATIC SOD CUTTER MUST BE MATCHED CORRECTLY.



ROLL SOD IMMEDIATELY TO ACHIEVE FIRM CONTACT WITH THE SOIL.

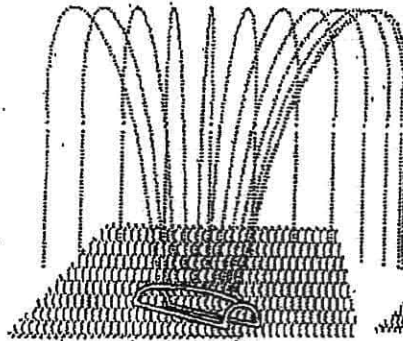

WATER TO A DEPTH OF 4" AS NEEDED. WATER WELL AS SOON AS THE SOD IS LAID.

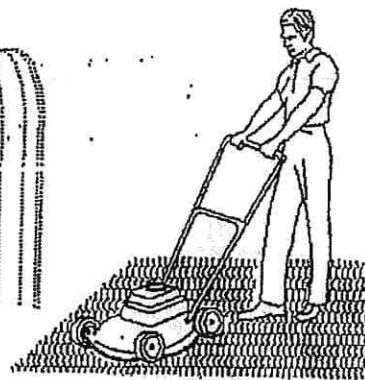

MOW WHEN THE SOD IS ESTABLISHED - IN 2-3 WEEKS, SET THE MOWER HIGH (2"-3").

### APPEARANCE OF GOOD SOD

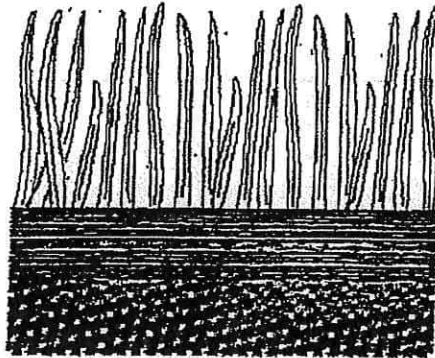

SHOOTS OR GRASS BLADES. GRASS SHOULD BE GREEN AND HEALTHY, MOWED AT A 2"-3" CUTTING HEIGHT.

THATCH - GRASS CLIPPINGS AND DEAD LEAVES, UP TO 1/2" THICK.

ROOT ZONE - SOIL AND ROOTS. SHOULD BE 1/2"-3/4" THICK, WITH DENSE ROOT MAT FOR STRENGTH.

Figure 1-22 Proper Sod Installation Techniques (VA Dept. of Conservation, 1992)

**Installation in Channels:**

- (1) Sod strips in waterways should be laid perpendicular to the direction of flow. Care should be taken to butt ends of strips tightly (see Figure 1-23).
- (2) After rolling or tamping, sod should be pegged or stapled to resist washout during the establishment period. Mesh or other netting may be pegged over the sod for extra protection in critical areas.

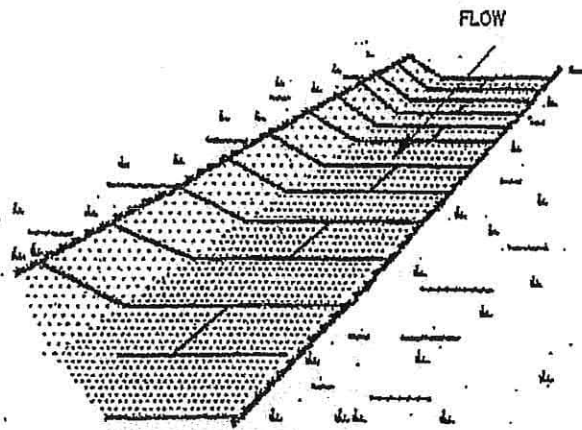

LAY SOD ACROSS THE DIRECTION OF FLOW.

USE PEGS OR STAPLES TO FASTEN SOD FIRMLY - AT THE ENDS OF STRIPS AND IN THE CENTER, OR EVERY 3-4 FEET IF THE STRIPS ARE LONG. WHEN READY TO MOW, DRIVE PEGS OR STAPLES FLUSH WITH THE GROUND.

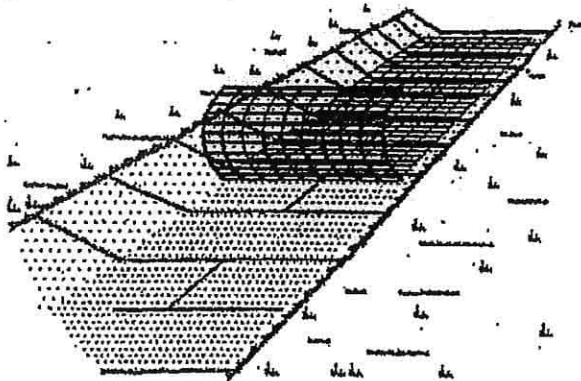
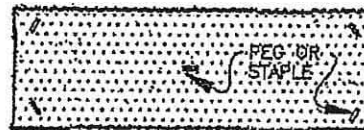
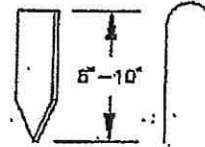

IN CRITICAL AREAS, SECURE SOD WITH NETTING. USE STAPLES.

Figure 1-23 Installation of Sod in a Channel (VA Dept. of Conservation, 1992)

#### Inspection and Maintenance Guidelines:

- (3) Sod should be inspected weekly and after each rain event to locate and repair any damage.
- (4) Damage from storms or normal construction activities such as tire ruts or disturbance of swale stabilization should be repaired as soon as practical.

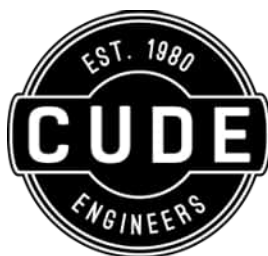

## ESTANCIA RANCH, UNIT 3

### *AGENT AUTHORIZATION FORM (TCEQ-0599)*

**Agent Authorization Form**  
For Required Signature  
Edwards Aquifer Protection Program  
Relating to 30 TAC Chapter 213  
Effective June 1, 1999

I Brian Otto,  
Print Name

Vice President of Land Acquisition & Land Development,  
Title - Owner/President/Other

of Meritage Homes of Texas, L.L.C.,  
Corporation/Partnership/Entity Name

have authorized Andrew R. Lowry, P.E.  
Print Name of Agent/Engineer

of Cude Engineers  
Print Name of Firm

to represent and act on the behalf of the above named Corporation, Partnership, or Entity for the purpose of preparing and submitting this plan application to the Texas Commission on Environmental Quality (TCEQ) for the review and approval consideration of regulated activities.

I also understand that:

1. The applicant is responsible for compliance with 30 Texas Administrative Code Chapter 213 and any condition of the TCEQ's approval letter. The TCEQ is authorized to assess administrative penalties of up to \$10,000 per day per violation.
2. For those submitting an application who are not the property owner, but who have the right to control and possess the property, additional authorization is required from the owner.
3. Application fees are due and payable at the time the application is submitted. The application fee must be sent to the TCEQ cashier or to the appropriate regional office. The application will not be considered until the correct fee is received by the commission.
4. A notarized copy of the Agent Authorization Form must be provided for the person preparing the application, and this form must accompany the completed application.
5. No person shall commence any regulated activity on the Edwards Aquifer Recharge Zone, Contributing Zone or Transition Zone until the appropriate application for the activity has been filed with and approved by the Executive Director.

SIGNATURE PAGE:

Brian Otto  
Applicant's Signature

10-31-23  
Date

THE STATE OF Texas §  
County of Bexar §

BEFORE ME, the undersigned authority, on this day personally appeared Brian Otto known to me to be the person whose name is subscribed to the foregoing instrument, and acknowledged to me that (s)he executed same for the purpose and consideration therein expressed.

GIVEN under my hand and seal of office on this 31 day of October, 2023



Sarah Wood  
NOTARY PUBLIC

Sarah Wood  
Typed or Printed Name of Notary

MY COMMISSION EXPIRES: 5/14/27

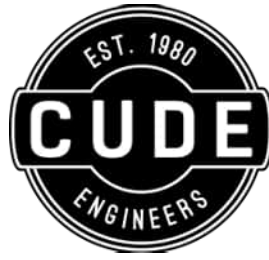

## ESTANCIA RANCH, UNIT 3

### *APPLICATION FEE FORM (TCEQ-0574)*

# Application Fee Form

## Texas Commission on Environmental Quality

Name of Proposed Regulated Entity: Estancia Ranch, Unit 3

Regulated Entity Location: City of San Antonio ETJ

Name of Customer: Meritage Homes of Texas, L.L.L.

Contact Person: Brian Otto

Phone: 210-402-6045

Customer Reference Number (if issued): CN 603298068

Regulated Entity Reference Number (if issued): RN \_\_\_\_\_

### Austin Regional Office (3373)

Hays

Travis

Williamson

### San Antonio Regional Office (3362)

Bexar

Medina

Uvalde

Comal

Kinney

Application fees must be paid by check, certified check, or money order, payable to the **Texas Commission on Environmental Quality**. Your canceled check will serve as your receipt. **This form must be submitted with your fee payment.** This payment is being submitted to:

Austin Regional Office

San Antonio Regional Office

Mailed to: TCEQ - Cashier

Overnight Delivery to: TCEQ - Cashier

Revenues Section

12100 Park 35 Circle

Mail Code 214

Building A, 3rd Floor

P.O. Box 13088

Austin, TX 78753

Austin, TX 78711-3088

(512)239-0357

### Site Location (Check All That Apply):

Recharge Zone

Contributing Zone

Transition Zone

<i>Type of Plan</i>	<i>Size</i>	<i>Fee Due</i>
Water Pollution Abatement Plan, Contributing Zone Plan: One Single Family Residential Dwelling	Acres	\$
Water Pollution Abatement Plan, Contributing Zone Plan: Multiple Single Family Residential and Parks	Acres	\$
Water Pollution Abatement Plan, Contributing Zone Plan: Non-residential	Acres	\$
Sewage Collection System	2,706.71 L.F.	\$ 1,353.36
Lift Stations without sewer lines	Acres	\$
Underground or Aboveground Storage Tank Facility	Tanks	\$
Piping System(s)(only)	Each	\$
Exception	Each	\$
Extension of Time	Each	\$

Signature: \_\_\_\_\_ 

Date: 10/30/23



# Application Fee Schedule

Texas Commission on Environmental Quality

Edwards Aquifer Protection Program 30 TAC Chapter 213 (effective 05/01/2008)

## ***Water Pollution Abatement Plans and Modifications***

### ***Contributing Zone Plans and Modifications***

<b><i>Project</i></b>	<b><i>Project Area in Acres</i></b>	<b><i>Fee</i></b>
One Single Family Residential Dwelling	< 5	\$650
Multiple Single Family Residential and Parks	< 5	\$1,500
	5 < 10	\$3,000
	10 < 40	\$4,000
	40 < 100	\$6,500
	100 < 500	\$8,000
	≥ 500	\$10,000
Non-residential (Commercial, industrial, institutional, multi-family residential, schools, and other sites where regulated activities will occur)	< 1	\$3,000
	1 < 5	\$4,000
	5 < 10	\$5,000
	10 < 40	\$6,500
	40 < 100	\$8,000
	≥ 100	\$10,000

### ***Organized Sewage Collection Systems and Modifications***

<b><i>Project</i></b>	<b><i>Cost per Linear Foot</i></b>	<b><i>Minimum Fee- Maximum Fee</i></b>
Sewage Collection Systems	\$0.50	\$650 - \$6,500

### ***Underground and Aboveground Storage Tank System Facility Plans and Modifications***

<b><i>Project</i></b>	<b><i>Cost per Tank or Piping System</i></b>	<b><i>Minimum Fee- Maximum Fee</i></b>
Underground and Aboveground Storage Tank Facility	\$650	\$650 - \$6,500

### ***Exception Requests***

<b><i>Project</i></b>	<b><i>Fee</i></b>
Exception Request	\$500

### ***Extension of Time Requests***

<b><i>Project</i></b>	<b><i>Fee</i></b>
Extension of Time Request	\$150

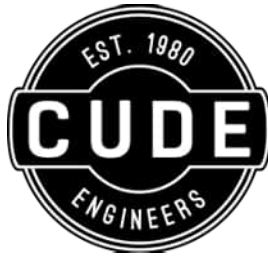

## ESTANCIA RANCH, UNIT 3

### *CORE DATA FORM (TCEQ-10400)*



# TCEQ Core Data Form

For detailed instructions on completing this form, please read the Core Data Form Instructions or call 512-239-5175.

## SECTION I: General Information

1. Reason for Submission (If other is checked please describe in space provided.)		
<input checked="" type="checkbox"/> New Permit, Registration or Authorization (Core Data Form should be submitted with the program application.)		
<input type="checkbox"/> Renewal (Core Data Form should be submitted with the renewal form)	<input type="checkbox"/> Other	
2. Customer Reference Number (if issued)	Follow this link to search for CN or RN numbers in Central Registry**	3. Regulated Entity Reference Number (if issued)
CN 603298068		RN

## SECTION II: Customer Information

4. General Customer Information		5. Effective Date for Customer Information Updates (mm/dd/yyyy)	
<input type="checkbox"/> New Customer		<input checked="" type="checkbox"/> Update to Customer Information	
<input type="checkbox"/> Change in Legal Name (Verifiable with the Texas Secretary of State or Texas Comptroller of Public Accounts)		<input type="checkbox"/> Change in Regulated Entity Ownership	
<i>The Customer Name submitted here may be updated automatically based on what is current and active with the Texas Secretary of State (SOS) or Texas Comptroller of Public Accounts (CPA).</i>			
6. Customer Legal Name (If an individual, print last name first: eg: Doe, John)		If new Customer, enter previous Customer below:	
7. TX SOS/CPA Filing Number		8. TX State Tax ID (11 digits)	9. Federal Tax ID (9 digits)
0800832535		32033186605	10. DUNS Number (if applicable)
11. Type of Customer:		Partnership: <input type="checkbox"/> General <input type="checkbox"/> Limited	
<input checked="" type="checkbox"/> Corporation		<input type="checkbox"/> Individual	
Government: <input type="checkbox"/> City <input type="checkbox"/> County <input type="checkbox"/> Federal <input type="checkbox"/> Local <input type="checkbox"/> State <input type="checkbox"/> Other		<input type="checkbox"/> Sole Proprietorship <input type="checkbox"/> Other:	
12. Number of Employees		13. Independently Owned and Operated?	
<input type="checkbox"/> 0-20 <input type="checkbox"/> 21-100 <input type="checkbox"/> 101-250 <input type="checkbox"/> 251-500 <input checked="" type="checkbox"/> 501 and higher		<input checked="" type="checkbox"/> Yes <input type="checkbox"/> No	
14. Customer Role (Proposed or Actual) – as it relates to the Regulated Entity listed on this form. Please check one of the following			
<input type="checkbox"/> Owner <input type="checkbox"/> Operator <input checked="" type="checkbox"/> Owner & Operator <input type="checkbox"/> Other:			
<input type="checkbox"/> Occupational Licensee <input type="checkbox"/> Responsible Party <input type="checkbox"/> VCP/BSA Applicant			
15. Mailing Address: 2722 W. Bitters Road, Suite 200			
City: San Antonio State: TX ZIP: 78248 ZIP + 4:			
16. Country Mailing Information (if outside USA)		17. E-Mail Address (if applicable)	
18. Telephone Number		19. Extension or Code	20. Fax Number (if applicable)

( 210 ) 402-6045

( ) -

### SECTION III: Regulated Entity Information

**21. General Regulated Entity Information** (If 'New Regulated Entity' is selected, a new permit application is also required.)

New Regulated Entity     Update to Regulated Entity Name     Update to Regulated Entity Information

*The Regulated Entity Name submitted may be updated, in order to meet TCEQ Core Data Standards (removal of organizational endings such as Inc, LP, or LLC).*

**22. Regulated Entity Name** (Enter name of the site where the regulated action is taking place.)

Estancia Ranch, Unit 3

**23. Street Address of the Regulated Entity:**

*(No PO Boxes)*

City

State

ZIP

ZIP + 4

**24. County**

If no Street Address is provided, fields 25-28 are required.

**25. Description to**

**Physical Location:**

Northeast of the intersection of Blanco Road and Broken Hollow.

**26. Nearest City**

**State**

**Nearest ZIP Code**

San Antonio

TX

78260

*Latitude/Longitude are required and may be added/updated to meet TCEQ Core Data Standards. (Geocoding of the Physical Address may be used to supply coordinates where none have been provided or to gain accuracy).*

**27. Latitude (N) in Decimal:**

29.732381

**28. Longitude (W) in Decimal:**

-98.507959

Degrees

Minutes

Seconds

Degrees

Minutes

Seconds

29

43

56.57

98

30

28.65

**29. Primary SIC Code**

**30. Secondary SIC Code**

**31. Primary NAICS Code**

**32. Secondary NAICS Code**

(4 digits)

(4 digits)

(5 or 6 digits)

(5 or 6 digits)

1521

236115

**33. What is the Primary Business of this entity?** (Do not repeat the SIC or NAICS description.)

Infrastructure and Home Building

**34. Mailing**

2722 W. Bitters Road, Suite 200

**Address:**

City

San Antonio

State

TX

ZIP

78248

ZIP + 4

**35. E-Mail Address:**

**36. Telephone Number**

**37. Extension or Code**

**38. Fax Number** (if applicable)

( 210 ) 402-6045

( ) -

**39. TCEQ Programs and ID Numbers** Check all Programs and write in the permits/registration numbers that will be affected by the updates submitted on this form. See the Core Data Form instructions for additional guidance.

<input type="checkbox"/> Dam Safety	<input type="checkbox"/> Districts	<input checked="" type="checkbox"/> Edwards Aquifer	<input type="checkbox"/> Emissions Inventory Air	<input type="checkbox"/> Industrial Hazardous Waste
<input type="checkbox"/> Municipal Solid Waste	<input type="checkbox"/> New Source Review Air	<input type="checkbox"/> OSSF	<input type="checkbox"/> Petroleum Storage Tank	<input type="checkbox"/> PWS
<input type="checkbox"/> Sludge	<input type="checkbox"/> Storm Water	<input type="checkbox"/> Title V Air	<input type="checkbox"/> Tires	<input type="checkbox"/> Used Oil
<input type="checkbox"/> Voluntary Cleanup	<input type="checkbox"/> Wastewater	<input type="checkbox"/> Wastewater Agriculture	<input type="checkbox"/> Water Rights	<input type="checkbox"/> Other:

### **SECTION IV: Preparer Information**

<b>40. Name:</b>	Andrew Lowry, P.E.	<b>41. Title:</b>	Associate
<b>42. Telephone Number</b>	<b>43. Ext./Code</b>	<b>44. Fax Number</b>	<b>45. E-Mail Address</b>
( 210 ) 681-2951		( ) -	alowry@cudeengineers.com

### **SECTION V: Authorized Signature**

46. By my signature below, I certify, to the best of my knowledge, that the information provided in this form is true and complete, and that I have signature authority to submit this form on behalf of the entity specified in Section II, Field 6 and/or as required for the updates to the ID numbers identified in field 39.

<b>Company:</b>	Meritage Homes of Texas, L.L.C.	<b>Job Title:</b>	VP of Land Acquisition & Land Development
<b>Name (In Print):</b>	Brian Otto	<b>Phone:</b>	( 210 ) 260- 6069
<b>Signature:</b>		<b>Date:</b>	10-31-23

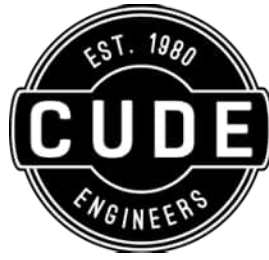

## ESTANCIA RANCH, UNIT 3

### *SURVEY INFORMATION*



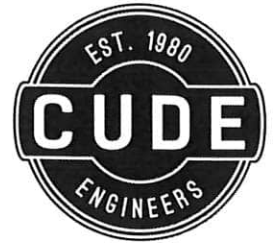

**LEGAL DESCRIPTION**  
**173.299 ACRES OF LAND**

173.299 acres of land located in the J. Rivas Survey Number 191, Abstract Number 612, County Block 4837, Bexar County, Texas and being a portion of that certain called 70 acres of land (Tract One) and the called 46.69 acres of land (Tract Two) conveyed to LOLO 7-11, LLC, as described in Document Number 20180050087, Official Public Records of Bexar County, Texas, a portion of that certain called 96 acres of land conveyed to Marilyn Gail Grosser, as described in Document Number 20180047284, Official Public Records of Bexar County, Texas and a portion of that certain called 5.00 acres of land conveyed to LOLO 7-11, LLC, as described in Document Number 20200047315, Official Public Records of Bexar County, Texas; said 173.299 acres being more particularly described as follows:

**COMMENCING**, at a found ½ inch iron rod located in the northerly right of way line of Specht Road and marking the southeasterly corner of the said 46.69 acres, same being the southwesterly corner of that certain called 38.028 acres of land conveyed to Cibolo Materials, L.P., as described in Document Number 20160012041, Official Public Records of Bexar County, Texas;

**THENCE**, North 00deg 22' 16" West, along the common boundary line between the said 46.69 acres and the said 38.028 acres, a distance of 300.00 feet, to a set ½ inch iron rod with "CUDE" cap, for the **POINT OF BEGINNING** of the herein described tract of land;

**THENCE**, South 89deg 39' 26" West, crossing the said 46.69 acres and the said 70 acres, a distance of 1,823.46 feet, to a set ½ inch iron rod with "CUDE" cap;

**THENCE**, continuing into the said 70 acres, the following courses:

South 00deg 04' 22" West, a distance of 274.83 feet, to a set ½ inch iron rod with "CUDE" cap;  
Southeasterly, along the arc of a curve to the left having a radius of 25.00 feet, a central angle of 90deg 25' 00", an arc length of 39.45 feet and a chord bearing: S 45deg 08' 06" E, 35.48 feet, to a set ½ inch iron rod with "CUDE" cap located in the northerly right of way line of Specht Road;

**THENCE**, South 89deg 39' 26" West, along the northerly right of way line of said Specht Road, a distance of 110.00 feet, to a set ½ inch iron rod with "CUDE" cap;

**THENCE**, leaving the northerly right of way line of Specht Road and into the said 70 acres, the following courses:

Northerly, along the arc of a curve to the left having a radius of 25.00 feet, a central angle of 89deg 35' 03", an arc length of 39.09 feet and a chord bearing: N 44deg 51' 54" E, 35.23 feet, to a set ½ inch iron rod with "CUDE" cap;  
North 00deg 04' 22" East, a distance of 275.19 feet, to a set ½ inch iron rod with "CUDE" cap;  
South 89deg 39' 26" West, a distance of 791.21 feet, to a set ½ inch iron rod with "CUDE" cap;  
North 00deg 29' 13" West, a distance of 808.65 feet, to a set ½ inch iron rod with "CUDE" cap;  
North 89deg 27' 14" West, a distance of 48.17 feet, to a set ½ inch iron rod with "CUDE" cap;



Westerly, along the arc of a curve to the left having a radius of 500.00 feet, a central angle of 02deg 17' 26", an arc length of 19.99 feet and a chord bearing: S 89deg 24' 03" W, 19.99 feet, to a set ½ inch iron rod with "CUDE" cap;

South 88deg 15' 20" West, a distance of 105.11 feet, to a set ½ inch iron rod with "CUDE" cap;

Westerly, along the arc of a curve to the right having a radius of 500.00 feet, a central angle of 02deg 17' 26", an arc length of 19.99 feet and a chord bearing: S 89deg 24' 03" W, 19.99 feet, to a set ½ inch iron rod with "CUDE" cap;

North 89deg 27' 14" West, a distance of 81.34 feet, to a set ½ inch iron rod with "CUDE" cap;

Southerly, along the arc of a curve to the left having a radius of 25.00 feet, a central angle of 91deg 01' 59", an arc length of 39.72 feet and a chord bearing: S 45deg 01' 47" W, 35.67 feet, to a set ½ inch iron rod with "CUDE" cap located in the easterly right of way line of Blanco Road (F.M. 2696);

**THENCE**, North 00deg 29' 13" West, along the easterly right of way line of Blanco Road, a distance of 120.02 feet, to a set ½ inch iron rod with "CUDE" cap;

**THENCE**, leaving the easterly right of way line of Blanco Road and into the said 70 acres, the following courses:

Easterly, along the arc of a curve to the left having a radius of 25.00 feet, a central angle of 88deg 58' 01", an arc length of 38.82 feet and a chord bearing: S 44deg 58' 13" E, 35.04 feet, to a set ½ inch iron rod with "CUDE" cap;

South 89deg 27' 14" East, a distance of 83.50 feet, to a set ½ inch iron rod with "CUDE" cap;

Easterly, along the arc of a curve to the right having a radius of 500.00 feet, a central angle of 02deg 17' 26", an arc length of 19.99 feet and a chord bearing: S 88deg 18' 31" E, 19.99 feet, to a set ½ inch iron rod with "CUDE" cap;

South 87deg 09' 48" East, a distance of 105.11 feet, to a set ½ inch iron rod with "CUDE" cap;

Easterly, along the arc of a curve to the left having a radius of 500.00 feet, a central angle of 02deg 17' 26", an arc length of 19.99 feet and a chord bearing: S 88deg 18' 31" E, 19.99 feet, to a set ½ inch iron rod with "CUDE" cap;

South 89deg 27' 14" East, a distance of 47.09 feet, to a set ½ inch iron rod with "CUDE" cap;

North 00deg 29' 13" West, crossing the said 70 acres and the said 5.00 acres, a distance of 488.37 feet, to a set ½ inch iron rod with "CUDE" cap located in the southerly line of the said 96 acres;

**THENCE**, into the said 96 acres, the following courses:

North 00deg 57' 39" East, a distance of 746.66 feet, to a set ½ inch iron rod with "CUDE" cap;

North 00deg 17' 03" East, a distance of 761.69 feet, to a set ½ inch iron rod with "CUDE" cap;

North 89deg 42' 57" West, a distance of 300.00 feet, to a set ½ inch iron rod with "CUDE" cap located in the easterly right of way line of Blanco Road (F.M. 2696);

**THENCE**, along the easterly right of way line of Blanco Road, the following courses:

North 00deg 17' 03" East, a distance of 295.99 feet, to a found TxDOT monument;

North 05deg 45' 07" East, a distance of 326.63 feet, to a found TxDOT monument;

North 00deg 08' 49" West, a distance of 122.35 feet, to a found ½ inch iron rod located in the northerly line of the said 96 acres;

**THENCE**, along the northerly line of the said 96 acres, the following courses:

South 67deg 55' 37" East, a distance of 713.88 feet, to a found 1 inch iron pipe;

South 10deg 12' 46" West, a distance of 167.89 feet, to a found 1 inch iron pipe;

South 60deg 53' 04" East, a distance of 335.81 feet, to a set ½ inch iron rod with "CUDE" cap;  
 South 64deg 27' 51" East, a distance of 362.03 feet, to a set ½ inch iron rod with "CUDE" cap;  
 South 51deg 56' 29" East, a distance of 139.58 feet, to a set ½ inch iron rod with "CUDE" cap;  
 South 65deg 50' 51" East, a distance of 479.80 feet, to a set ½ inch iron rod with "CUDE" cap;  
 South 71deg 41' 38" East, a distance of 795.10 feet, to a found ½ inch iron rod;  
 South 78deg 37' 47" East, a distance of 379.16 feet, to a found ½ inch iron rod located in the westerly line of the aforementioned 38.028 acres;

**THENCE**, along the westerly line of the said 38.028 acres, the following courses:

South 00deg 04' 14" East, a distance of 880.12 feet, to a found 5/8 inch iron rod marking the northeasterly corner of the said 46.69 acres;  
 South 00deg 22' 16" East, a distance of 1,354.12 feet, to the **POINT OF BEGINNING** and containing 173.299 acres of land, more or less.

Basis of bearings is the Texas State Plane Coordinate System, South Central Zone (4204), NAD 83 (93).

*James W. Russell 3/5/20*

James W. Russell  
 Registered Professional Land Surveyor No. 4230  
 Cude Engineers  
 4122 Pond Hill Road, Suite 101  
 San Antonio, Texas 78231  
 TBPLS Firm No. 10048500  
 TBPE Firm No. 455  
 Job No. 03473.000



NOTICE OF CONFIDENTIALITY RIGHTS: IF YOU ARE A NATURAL PERSON, YOU MAY REMOVE OR STRIKE ANY OR ALL OF THE FOLLOWING INFORMATION FROM ANY INSTRUMENT THAT TRANSFERS AN INTEREST IN REAL PROPERTY BEFORE IT IS FILED FOR RECORD IN THE PUBLIC RECORDS: YOUR SOCIAL SECURITY NUMBER OR YOUR DRIVER'S LICENSE NUMBER.

**SCANNED**

SPECIAL WARRANTY DEED

STATE OF TEXAS       §  
                                  §       KNOW ALL MEN BY THESE PRESENTS THAT:  
COUNTY OF BEXAR    §

**LOLO 7-11, LLC, a Texas limited liability company**, (referred to herein as "Grantor"), for and in consideration of the Ten Dollars (\$10.00) and other good and valuable consideration paid or given by **MERITAGE HOMES OF TEXAS, LLC, an Arizona limited liability company**, (referred to herein as "Grantee"), whose address is 2722 W Bitters Rd, Suite 200, San Antonio, Bexar County, Texas 78248, the receipt and sufficiency of which are hereby acknowledged and confessed, has GRANTED, BARGAINED, SOLD and CONVEYED, and by these presents does hereby GRANT, BARGAIN, SELL and CONVEY, unto Grantee, the following described tract of land and associated property rights located in Bexar County, Texas, and described as follows:

**BEING 173.299 acres of land located in the J. Rivas Survey Number 191, Abstract Number 612, County Block 4837, Bexar County, Texas and being a portion of that certain called 70 acres of land (Tract One) and the called 46.69 acres of land (Tract Two) conveyed to LOLO 7-11, LLC, as described in Document Number 20180050087, Official Public Records of Bexar County, Texas, a portion of that certain called 96 acres of land conveyed to Marilyn Gail Grosser, as described in Document Number 20180047284, Official Public Records of Bexar County, Texas and a portion of that certain called 5.00 acres of land conveyed to BUDDY 7-11, LLC, as described in Document Number 20190041157, Official Public Records of Bexar County, Texas; said 173.299 acres being more particularly described by Exhibit "A" attached hereto and made a part hereof.**

TOGETHER WITH, all and singular, the rights, benefits, privileges, easements, tenements, hereditaments, appurtenances, and interest thereon or in anywise appertaining thereto and with all improvements located thereon, together with all of Grantors interest, if any, in the mineral estate, water rights and permits, groundwater, wells and fixtures located thereon or pertaining thereto (said real property, rights and interests are collectively hereinafter referred to as the "Property").

THE PROPERTY IS BEING CONVEYED TO AND ACCEPTED BY GRANTEE IN IT'S "AS IS, WHERE IS" CONDITION, AND "WITH ALL FAULTS". ACCORDINGLY, WITH THE EXCEPTION OF THE WARRANTY OF TITLE MADE HEREIN. GRANTOR IS NOT MAKING AND HAS NOT MADE ANY WARRANTIES OR REPRESENTATIONS OF ANY KIND, EXPRESS OR IMPLIED, REGARDING THE PROPERTY.

This conveyance is made and accepted subject and subordinate to each and every of the matters set forth on attached Exhibit "B" attached hereto to the extent, and only to the extent, they are in force and effect and pertain to or affect the Property (all of such matters collectively referred to as the "Permitted Exceptions").

TO HAVE AND TO HOLD the Property, subject to the Permitted Exceptions, unto Grantee, and Grantee's successors and assigns, forever, and Grantor does hereby bind Grantor, and Grantor's successors and assigns, to WARRANT AND FOREVER DEFEND, all and singular, the Property, subject to the Permitted Exceptions, unto Grantee, and Grantee's successors, and assigns, against every person whomsoever lawfully claiming or to claim the same or any part thereof, by, through and under Grantor, but not otherwise.

Grantee, by its acceptance hereof, does hereby assume and agree to pay any and all ad valorem taxes and special and regular assessments pertaining to the Property for the calendar year 2020 and subsequent years, there having been a proper proration of ad valorem taxes and assessments for the current calendar year between Grantor and Grantee. If Grantee's use of the Property after the Effective Date hereof results in the assessment of additional taxes, penalties and interest for periods prior to the Effective Date hereof, such "rollback" taxes will be the obligation of Grantee. If Grantor's change in use of the Property prior to the Effective Date hereof or the denial of a special use valuation on the Property claimed by Grantor results in rollback taxes for periods prior to the Effective Date hereof, such rollback taxes shall be the obligation of Grantor.

Executed on the date set forth in the acknowledgment below to be effective the 13 day of March, 2020 (the "Effective Date")

(Signatures Appear on the Following Page)

(Signature Page-Special Warranty Deed)

GRANTOR:

LOLO 7-11, LLC, a Texas limited liability company  
By: DTB Investments, L.P. a Texas limited partnership  
Its: Sole Member  
By: DTB Management Company, LLC,  
a Texas limited liability company  
Its: General Partner

By: [Signature]  
Harold T. duPerier, III, its sole Manager/Member

THE STATE OF TEXAS

§  
§  
§

COUNTY OF KENDALL

This instrument was acknowledged before me on March 11, 2020, by Harold T. duPerier, III, sole Member of DTB Management Company, LLC a Texas limited liability company, General Partner of DTB Investments, L.P., a Texas limited partnership, Sole Member of BUDDY 7-11, LLC, a Texas limited liability company, on behalf of said company.

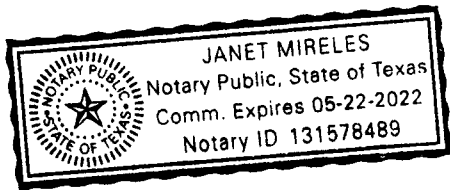

[Signature]  
NOTARY PUBLIC IN AND FOR  
THE STATE OF TEXAS

After Recording Return To:  
Western Title of Bandera, Inc.  
P.O. Box 1207  
Bandera, Texas 78003  
GF 19398

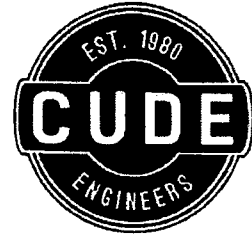

## EXHIBIT "A"

### LEGAL DESCRIPTION 173.299 ACRES OF LAND

173.299 acres of land located in the J. Rivas Survey Number 191, Abstract Number 612, County Block 4837, Bexar County, Texas and being a portion of that certain called 70 acres of land (Tract One) and the called 46.69 acres of land (Tract Two) conveyed to LOLO 7-11, LLC, as described in Document Number 20180050087, Official Public Records of Bexar County, Texas, a portion of that certain called 96 acres of land conveyed to Marilyn Gail Grosser, as described in Document Number 20180047284, Official Public Records of Bexar County, Texas and a portion of that certain called 5.00 acres of land conveyed to LOLO 7-11, LLC, as described in Document Number 20200047315, Official Public Records of Bexar County, Texas; said 173.299 acres being more particularly described as follows:

**COMMENCING**, at a found ½ inch iron rod located in the northerly right of way line of Specht Road and marking the southeasterly corner of the said 46.69 acres, same being the southwesterly corner of that certain called 38.028 acres of land conveyed to Cibolo Materials, L.P., as described in Document Number 20160012041, Official Public Records of Bexar County, Texas;

**THENCE**, North 00deg 22' 16" West, along the common boundary line between the said 46.69 acres and the said 38.028 acres, a distance of 300.00 feet, to a set ½ inch iron rod with "CUDE" cap, for the **POINT OF BEGINNING** of the herein described tract of land;

**THENCE**, South 89deg 39' 26" West, crossing the said 46.69 acres and the said 70 acres, a distance of 1,823.46 feet, to a set ½ inch iron rod with "CUDE" cap;

**THENCE**, continuing into the said 70 acres, the following courses:

South 00deg 04' 22" West, a distance of 274.83 feet, to a set ½ inch iron rod with "CUDE" cap;  
Southeasterly, along the arc of a curve to the left having a radius of 25.00 feet, a central angle of 90deg 25' 00", an arc length of 39.45 feet and a chord bearing: S 45deg 08' 06" E, 35.48 feet, to a set ½ inch iron rod with "CUDE" cap located in the northerly right of way line of Specht Road;

**THENCE**, South 89deg 39' 26" West, along the northerly right of way line of said Specht Road, a distance of 110.00 feet, to a set ½ inch iron rod with "CUDE" cap;

**THENCE**, leaving the northerly right of way line of Specht Road and into the said 70 acres, the following courses:

Northerly, along the arc of a curve to the left having a radius of 25.00 feet, a central angle of 89deg 35' 03", an arc length of 39.09 feet and a chord bearing: N 44deg 51' 54" E, 35.23 feet, to a set ½ inch iron rod with "CUDE" cap;  
North 00deg 04' 22" East, a distance of 275.19 feet, to a set ½ inch iron rod with "CUDE" cap;  
South 89deg 39' 26" West, a distance of 791.21 feet, to a set ½ inch iron rod with "CUDE" cap;  
North 00deg 29' 13" West, a distance of 808.65 feet, to a set ½ inch iron rod with "CUDE" cap;  
North 89deg 27' 14" West, a distance of 48.17 feet, to a set ½ inch iron rod with "CUDE" cap;

**EXHIBIT "A"**

Westerly, along the arc of a curve to the left having a radius of 500.00 feet, a central angle of 02deg 17' 26", an arc length of 19.99 feet and a chord bearing: S 89deg 24' 03" W, 19.99 feet, to a set ½ inch iron rod with "CUDE" cap;

South 88deg 15' 20" West, a distance of 105.11 feet, to a set ½ inch iron rod with "CUDE" cap;

Westerly, along the arc of a curve to the right having a radius of 500.00 feet, a central angle of 02deg 17' 26", an arc length of 19.99 feet and a chord bearing: S 89deg 24' 03" W, 19.99 feet, to a set ½ inch iron rod with "CUDE" cap;

North 89deg 27' 14" West, a distance of 81.34 feet, to a set ½ inch iron rod with "CUDE" cap;

Southerly, along the arc of a curve to the left having a radius of 25.00 feet, a central angle of 91deg 01' 59", an arc length of 39.72 feet and a chord bearing: S 45deg 01' 47" W, 35.67 feet, to a set ½ inch iron rod with "CUDE" cap located in the easterly right of way line of Blanco Road (F.M. 2696);

**THENCE**, North 00deg 29' 13" West, along the easterly right of way line of Blanco Road, a distance of 120.02 feet, to a set ½ inch iron rod with "CUDE" cap;

**THENCE**, leaving the easterly right of way line of Blanco Road and into the said 70 acres, the following courses:

Easterly, along the arc of a curve to the left having a radius of 25.00 feet, a central angle of 88deg 58' 01", an arc length of 38.82 feet and a chord bearing: S 44deg 58' 13" E, 35.04 feet, to a set ½ inch iron rod with "CUDE" cap;

South 89deg 27' 14" East, a distance of 83.50 feet, to a set ½ inch iron rod with "CUDE" cap;

Easterly, along the arc of a curve to the right having a radius of 500.00 feet, a central angle of 02deg 17' 26", an arc length of 19.99 feet and a chord bearing: S 88deg 18' 31" E, 19.99 feet, to a set ½ inch iron rod with "CUDE" cap;

South 87deg 09' 48" East, a distance of 105.11 feet, to a set ½ inch iron rod with "CUDE" cap;

Easterly, along the arc of a curve to the left having a radius of 500.00 feet, a central angle of 02deg 17' 26", an arc length of 19.99 feet and a chord bearing: S 88deg 18' 31" E, 19.99 feet, to a set ½ inch iron rod with "CUDE" cap;

South 89deg 27' 14" East, a distance of 47.09 feet, to a set ½ inch iron rod with "CUDE" cap;

North 00deg 29' 13" West, crossing the said 70 acres and the said 5.00 acres, a distance of 488.37 feet, to a set ½ inch iron rod with "CUDE" cap located in the southerly line of the said 96 acres;

**THENCE**, into the said 96 acres, the following courses:

North 00deg 57' 39" East, a distance of 746.66 feet, to a set ½ inch iron rod with "CUDE" cap;

North 00deg 17' 03" East, a distance of 761.69 feet, to a set ½ inch iron rod with "CUDE" cap;

North 89deg 42' 57" West, a distance of 300.00 feet, to a set ½ inch iron rod with "CUDE" cap located in the easterly right of way line of Blanco Road (F.M. 2696);

**THENCE**, along the easterly right of way line of Blanco Road, the following courses:

North 00deg 17' 03" East, a distance of 295.99 feet, to a found TxDOT monument;

North 05deg 45' 07" East, a distance of 326.63 feet, to a found TxDOT monument;

North 00deg 08' 49" West, a distance of 122.35 feet, to a found ½ inch iron rod located in the northerly line of the said 96 acres;

**THENCE**, along the northerly line of the said 96 acres, the following courses:

South 67deg 55' 37" East, a distance of 713.88 feet, to a found 1 inch iron pipe;

South 10deg 12' 46" West, a distance of 167.89 feet, to a found 1 inch iron pipe;

South 60deg 53' 04" East, a distance of 335.81 feet, to a set 1/2 inch iron rod with "CUDE" cap;  
South 64deg 27' 51" East, a distance of 362.03 feet, to a set 1/2 inch iron rod with "CUDE" cap;  
South 51deg 56' 29" East, a distance of 139.58 feet, to a set 1/2 inch iron rod with "CUDE" cap;  
South 65deg 50' 51" East, a distance of 479.80 feet, to a set 1/2 inch iron rod with "CUDE" cap;  
South 71deg 41' 38" East, a distance of 795.10 feet, to a found 1/2 inch iron rod;  
South 78deg 37' 47" East, a distance of 379.16 feet, to a found 1/2 inch iron rod located in the westerly line of the aforementioned 38.028 acres;

**THENCE**, along the westerly line of the said 38.028 acres, the following courses:

South 00deg 04' 14" East, a distance of 880.12 feet, to a found 5/8 inch iron rod marking the northeasterly corner of the said 46.69 acres;  
South 00deg 22' 16" East, a distance of 1,354.12 feet, to the **POINT OF BEGINNING** and containing 173.299 acres of land, more or less.

Basis of bearings is the Texas State Plane Coordinate System, South Central Zone (4204), NAD 83 (93).

*James W. Russell* 3/5/20

James W. Russell  
Registered Professional Land Surveyor No. 4230  
Cude Engineers  
4122 Pond Hill Road, Suite 101  
San Antonio, Texas 78231  
TBPLS Firm No. 10048500  
TBPE Firm No. 455  
Job No. 03473.000

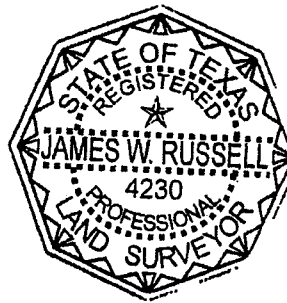

**EXHIBIT "A"**



EXHIBIT "B"

**Any visible and apparent easements on or across the property herein described, which are not shown of record.**

**All, leases, grants, exceptions or reservations of coal, lignite, oil, gas and other minerals, together with all rights, privileges, and immunities relating thereto, appearing in the Public Records whether listed in Schedule B or not. There may be leases, grants, exceptions or reservations of mineral interest that are not listed.**

**Property situated within the San Antonio River Authority.**

**Right of Way and Easement Agreement to Chief 7-11, LLC, recorded in Doc# 20190041154, Official Records of Bexar County, Texas.**

**Flood Zone AE noted on survey plat dated November 22, 2019, by James W Russell, RPLS #4230.**



\*VG-42-2020-20200055885\*

**File Information**

**FILED IN THE OFFICIAL PUBLIC RECORDS OF BEXAR COUNTY  
LUCY ADAME-CLARK, BEXAR COUNTY CLERK**

**Document Number:** 20200055885  
**Recorded Date:** March 16, 2020  
**Recorded Time:** 10:15 AM  
**Total Pages:** 8  
**Total Fees:** \$50.00

**\*\* THIS PAGE IS PART OF THE DOCUMENT \*\***

**\*\* Do Not Remove \*\***

Any provision herein which restricts the sale or use of the described real property because of race is invalid and unenforceable under Federal law

STATE OF TEXAS, COUNTY OF BEXAR

I hereby Certify that this instrument was FILED in File Number Sequence on this date and at the time stamped hereon by me and was duly RECORDED in the Official Public Record of Bexar County, Texas on:  
3/16/2020 10:15 AM



*Lucy Adame-Clark*  
Lucy Adame-Clark  
Bexar County Clerk

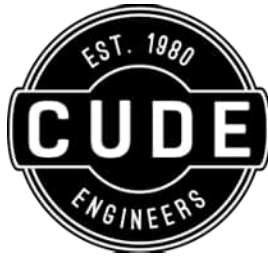

## ESTANCIA RANCH, UNIT 3

### *ATTACHMENTS*

Jon Niermann, *Chairman*  
Emily Lindley, *Commissioner*  
Bobby Janecka, *Commissioner*  
Toby Baker, *Executive Director*



## TEXAS COMMISSION ON ENVIRONMENTAL QUALITY

*Protecting Texas by Reducing and Preventing Pollution*

July 16, 2020

Mr. Brian Otto  
Meritage Homes of Texas, LLC  
2722 W. Bitters Road, Suite 200  
San Antonio, Texas 78248

Re: Edwards Aquifer, Bexar County and Comal County

NAME OF PROJECT: Estancia Ranch; Located at the northeast corner of Blanco Road and Spetch Road intersection; ETJ of San Antonio, Texas

TYPE OF PLAN: Request for Approval of a Water Pollution Abatement Plan (WPAP); 30 Texas Administrative Code (TAC) Chapter 213 Edwards Aquifer

Regulated Entity No. RN111029088; Additional ID. No. 13001126

Dear Mr. Otto:

The Texas Commission on Environmental Quality (TCEQ) has completed its review of the WPAP Application for the above-referenced project submitted to the San Antonio Regional Office by Cude Engineers on behalf of Meritage Homes of Texas, LLC on April 23, 2020. Final review of the WPAP was completed after additional material was received on May 29, 2020, June 11, 2020, June 26, 2020, July 7, 2020 and July 14, 2020. As presented to the TCEQ, the Temporary and Permanent Best Management Practices (BMPs) were selected and construction plans were prepared by a Texas Licensed Professional Engineer to be in general compliance with the requirements of 30 TAC Chapter 213. These planning materials were sealed, signed and dated by a Texas Licensed Professional Engineer. Therefore, based on the engineer's concurrence of compliance, the planning materials for construction of the proposed project and pollution abatement measures are hereby approved subject to applicable state rules and the conditions in this letter. The applicant or a person affected may file with the chief clerk a motion for reconsideration of the executive director's final action on this Edwards Aquifer Protection Plan. A motion for reconsideration must be filed no later than 23 days after the date of this approval letter. *This approval expires two (2) years from the date of this letter unless, prior to the expiration date, more than 10 percent of the construction has commenced on the project or an extension of time has been requested.*

### PROJECT DESCRIPTION

This project proposes a single-family residential development on a 271.88-acre site. The project proposes construction of 420 residential homes, street infrastructure, drainage facilities and utility infrastructure. Impervious cover totals 40.78 acres (14.99 percent) with 0.10 acres

being pre-rule. Project wastewater will be disposed of by conveyance to the Steven M. Clouse Water Recycling Center owned and operated by the San Antonio Water System.

#### PERMANENT POLLUTION ABATEMENT MEASURES

To prevent the pollution of stormwater runoff originating on-site or up-gradient of the site and potentially flowing across and off the site after construction, two (2) batch detention basins and one (1) engineered vegetative filter strip, designed using the TCEQ technical guidance document, Complying with the Edwards Aquifer Rules: Technical Guidance on Best Management Practices (2005), will be constructed to treat stormwater runoff. The required total suspended solids (TSS) treatment for this project is 33,195 pounds of TSS generated from the 40.68 acres of impervious cover. The approved measures meet the required 80 percent removal of the increased load in TSS caused by the project.

#### GEOLOGY

According to the geologic assessment included with the application, the site is located on the Bulverde member, Little Blanco member, Twin Sisters member and Doppenschmidt member of the Lower Glen Rose Limestone. Nine (9) non-sensitive manmade features in bedrock, four (4) non-sensitive geologic features and one (1) sensitive geologic feature were noted by the project geologist.

Sensitive karst feature S-1 (solution enlarged fractures) will have a natural buffer that is based on the drainage area of the feature. The buffer is shown on the site plan. The buffer is to remain in a natural state and a zone of non-construction. The site assessment conducted on May 22, 2020 revealed that the site was generally as described in the application.

#### SPECIAL CONDITIONS

- I. The permanent pollution abatement measures shall be operational prior to first occupancy of respective drainage basins.
- II. All sediment and/or media removed from the batch detention basins during maintenance activities shall be properly disposed of according to 30 TAC 330 or 30 TAC 335, as applicable.

#### STANDARD CONDITIONS

1. Pursuant to Chapter 7 Subchapter C of the Texas Water Code, any violations of the requirements in 30 TAC Chapter 213 may result in administrative penalties.
2. The holder of the approved Edwards Aquifer protection plan must comply with all provisions of 30 TAC Chapter 213 and all best management practices and measures contained in the approved plan. Additional and separate approvals, permits, registrations and/or authorizations from other TCEQ Programs (i.e., Stormwater, Water Rights, UIC) can be required depending on the specifics of the plan.
3. In addition to the rules of the Commission, the applicant may also be required to comply with state and local ordinances and regulations providing for the protection of water quality.

Prior to Commencement of Construction:

4. Within 60 days of receiving written approval of an Edwards Aquifer Protection Plan, the applicant must submit to the San Antonio Regional Office, proof of recordation of notice in the county deed records, with the volume and page number(s) of the county deed records of the county in which the property is located. A description of the property boundaries shall be included in the deed recordation in the county deed records. A suggested form (Deed Recordation Affidavit, TCEQ-0625) that you may use to deed record the approved WPAP is enclosed.
5. All contractors conducting regulated activities at the referenced project location shall be provided a copy of this notice of approval. At least one complete copy of the approved WPAP and this notice of approval shall be maintained at the project location until all regulated activities are completed.
6. Modification to the activities described in the referenced WPAP application following the date of approval may require the submittal of a plan to modify this approval, including the payment of appropriate fees and all information necessary for its review and approval prior to initiating construction of the modifications.
7. The applicant must provide written notification of intent to commence construction, replacement, or rehabilitation of the referenced project. Notification must be submitted to the San Antonio Regional Office no later than 48 hours prior to commencement of the regulated activity. Written notification must include the date on which the regulated activity will commence, the name of the approved plan and program ID number for the regulated activity, and the name of the prime contractor with the name and telephone number of the contact person. The executive director will use the notification to determine if the approved plan is eligible for an extension.
8. Temporary erosion and sedimentation (E&S) controls, i.e., silt fences, rock berms, stabilized construction entrances, or other controls described in the approved WPAP, must be installed prior to construction and maintained during construction. Temporary E&S controls may be removed when vegetation is established and the construction area is stabilized. If a water quality pond is proposed, it shall be used as a sedimentation basin during construction. The TCEQ may monitor stormwater discharges from the site to evaluate the adequacy of temporary E&S control measures. Additional controls may be necessary if excessive solids are being discharged from the site.
9. All borings with depths greater than or equal to 20 feet must be plugged with non-shrink grout from the bottom of the hole to within three (3) feet of the surface. The remainder of the hole must be backfilled with cuttings from the boring. All borings less than 20 feet must be backfilled with cuttings from the boring. All borings must be backfilled or plugged within four (4) days of completion of the drilling operation. Voids may be filled with gravel.

During Construction:

10. During the course of regulated activities related to this project, the applicant or agent shall comply with all applicable provisions of 30 TAC Chapter 213, Edwards Aquifer. The applicant shall remain responsible for the provisions and conditions of this approval until such responsibility is legally transferred to another person or entity.
11. This approval does not authorize the installation of temporary aboveground storage tanks on this project. If the contractor desires to install a temporary aboveground storage tank for use during construction, an application to modify this approval must be submitted and approved prior to installation. The application must include information related to tank location and spill containment. Refer to Standard Condition No. 6, above.

12. If any sensitive feature (caves, solution cavities, sink holes, etc.) is discovered during construction, all regulated activities near the feature must be suspended immediately. The applicant or his agent must immediately notify the San Antonio Regional Office of the discovery of the feature. Regulated activities near the feature may not proceed until the executive director has reviewed and approved the methods proposed to protect the feature and the aquifer from potentially adverse impacts to water quality. The plan must be sealed, signed, and dated by a Texas Licensed Professional Engineer.
13. Four (4) wells exist on the site. All water wells, including injection, dewatering, and monitoring wells must be in compliance with the requirements of the Texas Department of Licensing and Regulation under Title 16 TAC Chapter 76 (relating to Water Well Drillers and Pump Installers) and all other locally applicable rules, as appropriate.
14. If sediment escapes the construction site, the sediment must be removed at a frequency sufficient to minimize offsite impacts to water quality (e.g., fugitive sediment in street being washed into surface streams or sensitive features by the next rain). Sediment must be removed from sediment traps or sedimentation ponds not later than when design capacity has been reduced by 50 percent. Litter, construction debris, and construction chemicals shall be prevented from becoming stormwater discharge pollutants.
15. Intentional discharges of sediment laden water are not allowed. If dewatering becomes necessary, the discharge will be filtered through appropriately selected best management practices. These may include vegetated filter strips, sediment traps, rock berms, silt fence rings, etc.
16. The following records shall be maintained and made available to the executive director upon request: the dates when major grading activities occur, the dates when construction activities temporarily or permanently cease on a portion of the site, and the dates when stabilization measures are initiated.
17. Stabilization measures shall be initiated as soon as practicable in portions of the site where construction activities have temporarily or permanently ceased, and construction activities will not resume within 21 days. When the initiation of stabilization measures by the 14th day is precluded by weather conditions, stabilization measures shall be initiated as soon as practicable.

After Completion of Construction:

18. A Texas Licensed Professional Engineer must certify in writing that the permanent BMPs or measures were constructed as designed. The certification letter must be submitted to the San Antonio Regional Office within 30 days of site completion.
19. The applicant shall be responsible for maintaining the permanent BMPs after construction until such time as the maintenance obligation is either assumed in writing by another entity having ownership or control of the property (such as without limitation, an owner's association, a new property owner or lessee, a district, or municipality) or the ownership of the property is transferred to the entity. The regulated entity shall then be responsible for maintenance until another entity assumes such obligations in writing or ownership is transferred. A copy of the transfer of responsibility must be filed with the executive director through San Antonio Regional Office within 30 days of the transfer. A copy of the transfer form (TCEQ-10263) is enclosed.
20. Upon legal transfer of this property, the new owner(s) is required to comply with all terms of the approved Edwards Aquifer protection plan. If the new owner intends to commence any new regulated activity on the site, a new Edwards Aquifer protection plan that specifically addresses the new activity must be submitted to the executive director. Approval of the plan for the new regulated activity by the executive director is required prior to commencement of the new regulated activity.

Mr. Brian Otto  
July 16, 2020  
Page 5

21. An Edwards Aquifer protection plan approval or extension will expire and no extension will be granted if more than 50 percent of the total construction has not been completed within ten years from the initial approval of a plan. A new Edwards Aquifer protection plan must be submitted to the San Antonio Regional Office with the appropriate fees for review and approval by the executive director prior to commencing any additional regulated activities.
22. At project locations where construction is initiated and abandoned, or not completed, the site shall be returned to a condition such that the aquifer is protected from potential contamination.

This action is taken under authority delegated by the Executive Director of the Texas Commission on Environmental Quality. If you have any questions or require additional information, please contact Dianne Pavlicek-Mesa, P.G., of the Edwards Aquifer Protection Program of the San Antonio Regional Office at 210-403-4074.

Sincerely,

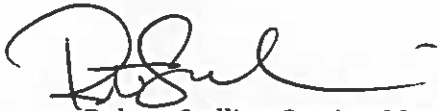

Robert Sadler, Section Manager  
Edwards Aquifer Protection Program  
Texas Commission on Environmental Quality

RCS/dpm

Enclosure: Deed Recordation Affidavit, Form TCEQ-0625  
Change in Responsibility for Maintenance of Permanent BMPs, Form TCEQ-10263

cc: Mr. David Cupit, P.E., Cude Engineers  
Ms. Renee Green, P.E., Bexar County Public Works  
Mr. Roland Ruiz, Edwards Aquifer Authority  
Mr. Scott Halty, San Antonio Water System  
Mr. George Wissmann, Trinity Glen Rose Groundwater Conservation District  
Mr. Thomas H. Hornseth, P.E., Comal County Engineer  
Mr. H. L. Saur, Comal Trinity Groundwater Conservation District



**Deed Recordation Affidavit  
Edwards Aquifer Protection Plan**

THE STATE OF TEXAS     §

County of \_\_\_\_\_ §

BEFORE ME, the undersigned authority, on this day personally appeared \_\_\_\_\_ who, being duly sworn by me, deposes and says:

- (1) That my name is \_\_\_\_\_ and that I own the real property described below.
- (2) That said real property is subject to an EDWARDS AQUIFER PROTECTION PLAN which was required under the 30 Texas Administrative Code (TAC) Chapter 213.
- (3) That the EDWARDS AQUIFER PROTECTION PLAN for said real property was approved by the Texas Commission on Environmental Quality (TCEQ) on \_\_\_\_\_.

A copy of the letter of approval from the TCEQ is attached to this affidavit as Exhibit A and is incorporated herein by reference.

- (4) The said real property is located in \_\_\_\_\_ County, Texas, and the legal description of the property is as follows:

\_\_\_\_\_  
LANDOWNER-AFFIANT

SWORN AND SUBSCRIBED TO before me, on this \_\_ day of \_\_\_\_\_, \_\_\_\_\_.

\_\_\_\_\_  
NOTARY PUBLIC

THE STATE OF \_\_\_\_\_ §

County of \_\_\_\_\_ §

BEFORE ME, the undersigned authority, on this day personally appeared \_\_\_\_\_ known to me to be the person whose name is subscribed to the foregoing instrument, and acknowledged to me that (s)he executed same for the purpose and consideration therein expressed.

GIVEN under my hand and seal of office on this \_\_ day of \_\_\_\_\_, \_\_\_\_\_.

\_\_\_\_\_  
NOTARY PUBLIC

\_\_\_\_\_  
Typed or Printed Name of Notary

MY COMMISSION EXPIRES: \_\_\_\_\_

**Change in Responsibility for Maintenance  
on Permanent Best Management Practices and Measures**

The applicant is no longer responsible for maintaining the permanent best management practice (BMP) and other measures. The project information and the new entity responsible for maintenance is listed below.

Customer: \_\_\_\_\_

Regulated Entity Name: \_\_\_\_\_

Site Address: \_\_\_\_\_

City, Texas, Zip: \_\_\_\_\_

County: \_\_\_\_\_

Approval Letter Date: \_\_\_\_\_

BMPs for the project: \_\_\_\_\_

New Responsible Party: \_\_\_\_\_

Name of contact: \_\_\_\_\_

Mailing Address: \_\_\_\_\_

City, State: \_\_\_\_\_ Zip: \_\_\_\_\_

Telephone: \_\_\_\_\_ FAX: \_\_\_\_\_

\_\_\_\_\_  
Signature of New Responsible Party                      Date

I acknowledge and understand that I am assuming full responsibility for maintaining all permanent best management practices and measures approved by the TCEQ for the site, until another entity assumes such obligations in writing or ownership is transferred.

If you have questions on how to fill out this form or about the Edwards Aquifer protection program, please contact us at 210/490-3096 for projects located in the San Antonio Region or 512/339-2929 for projects located in the Austin Region.

Individuals are entitled to request and review their personal information that the agency gathers on its forms. They may also have any errors in their information corrected. To review such information, contact us at 512/239-3282.