

Brauntex Materials, Inc.

Modification to Aboveground  
Storage Tank (AST) Plan Application

Brauntex Truck Shop  
1870 Wald Road  
New Braunfels, Texas 78132  
Comal County

Submitted to: TCEQ Region 13, San Antonio

Prepared By:



Boerne, Texas  
830-249-8284

Date: March 2024  
Project No. 10101-061  
-AK-

Signature: \_\_\_\_\_

A handwritten signature in black ink that reads "Andrea Kidd".

Andrea Kidd, P.E. - License No. 132541

TX PE Firm No. 4524

Date: 3/4/2024



# Modification of a Previously Approved Plan Checklist

- **Edwards Aquifer Application Cover Page (TCEQ-20705)**
- **General Information Form (TCEQ-0587)**
  - Attachment A - Road Map
  - Attachment B - USGS / Edwards Recharge Zone Map
  - Attachment C - Project Description
- **Geologic Assessment Form (TCEQ-0585)**
  - Attachment A - Geologic Assessment Table (TCEQ-0585-Table)
  - Attachment B - Stratigraphic Column
  - Attachment C - Site Geology
  - Attachment D - Site Geologic Map(s)
- **Modification of a Previously Approved Plan (TCEQ-0590)**
  - Attachment A - Original Approval Letter and Approved Modification Letters
  - Attachment B - Narrative of Proposed Modification
  - Attachment C - Current Site Plan of the Approved Project
- **Application Form (include any applicable to the proposed modification):**
  - Aboveground Storage Tank Facility Plan (TCEQ-0575)
  - Organized Sewage Collection System Application (TCEQ-0582)
  - Underground Storage Tank Facility Plan (TCEQ-0583)
  - Water Pollution Abatement Plan Application (TCEQ-0584)
  - Lift Station / Force Main System Application (TCEQ-0624)
- **Temporary Stormwater Section (TCEQ-0602)**
  - Attachment A - Spill Response Actions
  - Attachment B - Potential Sources of Contamination
  - Attachment C - Sequence of Major Activities
  - Attachment D - Temporary Best Management Practices and Measures
  - Attachment E - Request to Temporarily Seal a Feature (if requested)
  - Attachment F - Structural Practices
  - Attachment G - Drainage Area Map
  - Attachment H - Temporary Sediment Pond(s) Plans and Calculations
  - Attachment I - Inspection and Maintenance for BMPs
  - Attachment J - Schedule of Interim and Permanent Soil Stabilization Practices
- **Permanent Stormwater Section (TCEQ-0600), if necessary**
  - Attachment A - 20% or Less Impervious Cover Declaration (if requested for multi-family, school, or small business site)
  - Attachment B - BMPs for Upgradient Stormwater

Attachment C - BMPs for On-site Stormwater

Attachment D - BMPs for Surface Streams

Attachment E - Request to Seal Features, if sealing a feature

Attachment F - Construction Plans

Attachment G - Inspection, Maintenance, Repair and Retrofit Plan

Attachment H - Pilot-Scale Field Testing Plan (if requested)

Attachment I - Measures for Minimizing Surface Stream Contamination

- **Agent Authorization Form (TCEQ-0599), if application submitted by agent**
- **Application Fee Form (TCEQ-0574)**
- **Check Payable to the “Texas Commission on Environmental Quality”**
- **Core Data Form (TCEQ-10400)**

# Texas Commission on Environmental Quality

## Edwards Aquifer Application Cover Page

---

### Our Review of Your Application

**The Edwards Aquifer Program staff conducts an administrative and technical review of all applications. The turnaround time for administrative review can be up to 30 days as outlined in 30 TAC 213.4(e). Generally administrative completeness is determined during the intake meeting or within a few days of receipt. The turnaround time for technical review of an administratively complete Edwards Aquifer application is 90 days as outlined in 30 TAC 213.4(e). Please know that the review and approval time is directly impacted by the quality and completeness of the initial application that is received. In order to conduct a timely review, it is imperative that the information provided in an Edwards Aquifer application include final plans, be accurate, complete, and in compliance with [30 TAC 213](#).**

### Administrative Review

1. [Edwards Aquifer applications](#) must be deemed administratively complete before a technical review can begin. To be considered administratively complete, the application must contain completed forms and attachments, provide the requested information, and meet all the site plan requirements. The submitted application and plan sheets should be final plans. Please submit one full-size set of plan sheets with the original application, and half-size sets with the additional copies.

To ensure that all applicable documents are included in the application, the program has developed tools to guide you and web pages to provide all forms, checklists, and guidance. Please visit the below website for assistance: <http://www.tceq.texas.gov/field/eapp>.

2. This Edwards Aquifer Application Cover Page form (certified by the applicant or agent) must be included in the application and brought to the administrative review meeting.
3. Administrative reviews are scheduled with program staff who will conduct the review. Applicants or their authorized agent should call the appropriate regional office, according to the county in which the project is located, to schedule a review. The average meeting time is one hour.
4. In the meeting, the application is examined for administrative completeness. Deficiencies will be noted by staff and emailed or faxed to the applicant and authorized agent at the end of the meeting, or shortly after. Administrative deficiencies will cause the application to be deemed incomplete and returned.

An appointment should be made to resubmit the application. The application is re-examined to ensure all deficiencies are resolved. The application will only be deemed administratively complete when all administrative deficiencies are addressed.

5. If an application is received by mail, courier service, or otherwise submitted without a review meeting, the administrative review will be conducted within 30 days. The applicant and agent will be contacted with the results of the administrative review. If the application is found to be administratively incomplete, it can be retrieved from the regional office or returned by regular mail. If returned by mail, the regional office may require arrangements for return shipping.
6. If the geologic assessment was completed before October 1, 2004 and the site contains “possibly sensitive” features, the assessment must be updated in accordance with the *Instructions to Geologists* (TCEQ-0585 Instructions).

### Technical Review

1. When an application is deemed administratively complete, the technical review period begins. The regional office will distribute copies of the application to the identified affected city, county, and groundwater conservation district whose jurisdiction includes the subject site. These entities and the public have 30 days to provide comments on the application to the regional office. All comments received are reviewed by TCEQ.
2. A site assessment is usually conducted as part of the technical review, to evaluate the geologic assessment and observe existing site conditions. The site must be accessible to our staff. The site boundaries should be



clearly marked, features identified in the geologic assessment should be flagged, roadways marked and the alignment of the Sewage Collection System and manholes should be staked at the time the application is submitted. If the site is not marked the application may be returned.

3. We evaluate the application for technical completeness and contact the applicant and agent via Notice of Deficiency (NOD) to request additional information and identify technical deficiencies. There are two deficiency response periods available to the applicant. There are 14 days to resolve deficiencies noted in the first NOD. If a second NOD is issued, there is an additional 14 days to resolve deficiencies. If the response to the second notice is not received, is incomplete or inadequate, or provides new information that is incomplete or inadequate, the application must be withdrawn or will be denied. Please note that because the technical review is underway, whether the application is withdrawn or denied **the application fee will be forfeited.**
4. The program has 90 calendar days to complete the technical review of the application. If the application is technically adequate, such that it complies with the Edwards Aquifer rules, and is protective of the Edwards Aquifer during and after construction, an approval letter will be issued. Construction or other regulated activity may not begin until an approval is issued.

**Mid-Review Modifications**

It is important to have final site plans prior to beginning the permitting process with TCEQ to avoid delays.

Occasionally, circumstances arise where you may have significant design and/or site plan changes after your Edwards Aquifer application has been deemed administratively complete by TCEQ. This is considered a “Mid-Review Modification”. Mid-Review Modifications may require redistribution of an application that includes the proposed modifications for public comment.

If you are proposing a Mid-Review Modification, two options are available:

- If the technical review has begun your application can be denied/withdrawn, your fees will be forfeited, and the plan will have to be resubmitted.
- TCEQ can continue the technical review of the application as it was submitted, and a modification application can be submitted at a later time.

If the application is denied/withdrawn, the resubmitted application will be subject to the administrative and technical review processes and will be treated as a new application. The application will be redistributed to the affected jurisdictions.

Please contact the regional office if you have questions. If your project is located in Williamson, Travis, or Hays County, contact TCEQ’s Austin Regional Office at 512-339-2929. If your project is in Comal, Bexar, Medina, Uvalde, or Kinney County, contact TCEQ’s San Antonio Regional Office at 210-490-3096

Please fill out all required fields below and submit with your application.

<b>1. Regulated Entity Name:</b> Brauntex Truck Shop				<b>2. Regulated Entity No.:</b> 100853555					
<b>3. Customer Name:</b> Brauntex Materials, Inc.				<b>4. Customer No.:</b> 600618581					
<b>5. Project Type:</b> (Please circle/check one)	New	Modification		Extension	Exception				
<b>6. Plan Type:</b> (Please circle/check one)	WPAP	CZP	SCS	UST	AST	EXP	EXT	Technical Clarification	Optional Enhanced Measures
<b>7. Land Use:</b> (Please circle/check one)	Residential	Non-residential			<b>8. Site (acres):</b>		6.53		
<b>9. Application Fee:</b>	\$5,200	<b>10. Permanent BMP(s):</b>			N/A				
<b>11. SCS (Linear Ft.):</b>	N/A	<b>12. AST/UST (No. Tanks):</b>			8				
<b>13. County:</b>	Comal	<b>14. Watershed:</b>			Comal River- Guadalupe River				

# Application Distribution

Instructions: Use the table below to determine the number of applications required. One original and one copy of the application, plus additional copies (as needed) for each affected incorporated city, county, and groundwater conservation district are required. Linear projects or large projects, which cross into multiple jurisdictions, can require additional copies. Refer to the “Texas Groundwater Conservation Districts within the EAPP Boundaries” map found at:

[http://www.tceq.texas.gov/assets/public/compliance/field\\_ops/eapp/EAPP%20GWCD%20map.pdf](http://www.tceq.texas.gov/assets/public/compliance/field_ops/eapp/EAPP%20GWCD%20map.pdf)

For more detailed boundaries, please contact the conservation district directly.

<b>Austin Region</b>			
<b>County:</b>	<b>Hays</b>	<b>Travis</b>	<b>Williamson</b>
Original (1 req.)	—	—	—
Region (1 req.)	—	—	—
County(ies)	—	—	—
Groundwater Conservation District(s)	<input type="checkbox"/> Edwards Aquifer Authority <input type="checkbox"/> Barton Springs/ Edwards Aquifer <input type="checkbox"/> Hays Trinity <input type="checkbox"/> Plum Creek	<input type="checkbox"/> Barton Springs/ Edwards Aquifer	NA
City(ies) Jurisdiction	<input type="checkbox"/> Austin <input type="checkbox"/> Buda <input type="checkbox"/> Dripping Springs <input type="checkbox"/> Kyle <input type="checkbox"/> Mountain City <input type="checkbox"/> San Marcos <input type="checkbox"/> Wimberley <input type="checkbox"/> Woodcreek	<input type="checkbox"/> Austin <input type="checkbox"/> Bee Cave <input type="checkbox"/> Pflugerville <input type="checkbox"/> Rollingwood <input type="checkbox"/> Round Rock <input type="checkbox"/> Sunset Valley <input type="checkbox"/> West Lake Hills	<input type="checkbox"/> Austin <input type="checkbox"/> Cedar Park <input type="checkbox"/> Florence <input type="checkbox"/> Georgetown <input type="checkbox"/> Jerrell <input type="checkbox"/> Leander <input type="checkbox"/> Liberty Hill <input type="checkbox"/> Pflugerville <input type="checkbox"/> Round Rock

<b>San Antonio Region</b>					
<b>County:</b>	<b>Bexar</b>	<b>Comal</b>	<b>Kinney</b>	<b>Medina</b>	<b>Uvalde</b>
Original (1 req.)	—	<u>X</u>	—	—	—
Region (1 req.)	—	<u>X</u>	—	—	—
County(ies)	—	<u>X</u>	—	—	—
Groundwater Conservation District(s)	<input type="checkbox"/> Edwards Aquifer Authority <input type="checkbox"/> Trinity-Glen Rose	<input checked="" type="checkbox"/> Edwards Aquifer Authority	<input type="checkbox"/> Kinney	<input type="checkbox"/> EAA <input type="checkbox"/> Medina	<input type="checkbox"/> EAA <input type="checkbox"/> Uvalde
City(ies) Jurisdiction	<input type="checkbox"/> Castle Hills <input type="checkbox"/> Fair Oaks Ranch <input type="checkbox"/> Helotes <input type="checkbox"/> Hill Country Village <input type="checkbox"/> Hollywood Park <input type="checkbox"/> San Antonio (SAWS) <input type="checkbox"/> Shavano Park	<input type="checkbox"/> Bulverde <input type="checkbox"/> Fair Oaks Ranch <input type="checkbox"/> Garden Ridge <input checked="" type="checkbox"/> New Braunfels <input type="checkbox"/> Schertz	NA	<input type="checkbox"/> San Antonio ETJ (SAWS)	NA

I certify that to the best of my knowledge, that the application is complete and accurate. This application is hereby submitted to TCEQ for administrative review and technical review.

Andrea Kidd, P.E.  
 TX License No. 132541 | Firm No. 4524

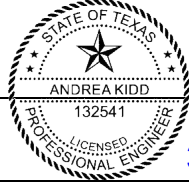

Print Name of Engineer/Authorized Agent

*Andrea Kidd*

3/4/2024

Signature of Engineer/Authorized Agent

Date

**\*\*FOR TCEQ INTERNAL USE ONLY\*\***

Date(s) Reviewed:		Date Administratively Complete:	
Received From:		Correct Number of Copies:	
Received By:		Distribution Date:	
EAPP File Number:		Complex:	
Admin. Review(s) (No.):		No. AR Rounds:	
Delinquent Fees (Y/N):		Review Time Spent:	
Lat./Long. Verified:		SOS Customer Verification:	
Agent Authorization Complete/Notarized (Y/N):		Fee Check:	Payable to TCEQ (Y/N):
Core Data Form Complete (Y/N):			Signed (Y/N):
Core Data Form Incomplete Nos.:			Less than 90 days old (Y/N):

# General Information Form

## Texas Commission on Environmental Quality

For Regulated Activities on the Edwards Aquifer Recharge and Transition Zones and Relating to 30 TAC §213.4(b) & §213.5(b)(2)(A), (B) Effective June 1, 1999

**To ensure that the application is administratively complete, confirm that all fields in the form are complete, verify that all requested information is provided, consistently reference the same site and contact person in all forms in the application, and ensure forms are signed by the appropriate party.**

**Note: Including all the information requested in the form and attachments contributes to more streamlined technical reviews.**

## Signature

To the best of my knowledge, the responses to this form accurately reflect all information requested concerning the proposed regulated activities and methods to protect the Edwards Aquifer. This **General Information Form** is hereby submitted for TCEQ review. The application was prepared by:

Print Name of Engineer/Agent: Andrea Kidd, P.E.

TX License No. 132541 / TX Firm No. 4524

Date: 3/4/2024

Signature of Engineer/Agent:

Andrea Kidd



## Project Information

1. Regulated Entity Name: Brauntex Truck Shop
2. County: Comal
3. Stream Basin: Guadalupe River Basin
4. Groundwater Conservation District (If applicable): Comal Trinity GCD & Edwards Aquifer Authority
5. Edwards Aquifer Zone:
  - Recharge Zone
  - Transition Zone
6. Plan Type:
  - WPAP
  - SCS
  - Modification
  - AST
  - UST
  - Exception Request

7. Customer (Applicant):

Contact Person: William D. Fischer

Entity: Brauntex Materials, Inc.

Mailing Address: 1504 Wald Rd

City, State: New Braunfels, TX

Zip: 78132

Telephone: (830) 625-6276

FAX:

Email Address: wdfischer@brauntexamaterials.com

8. Agent/Representative (If any):

Contact Person: Andrea Kidd, P.E.

Entity: Westward Environmental, Inc.

Mailing Address: P.O. Box 2205

City, State: Boerne, TX

Zip: 78006

Telephone: 830-249-8284

FAX: 830-249-0221

Email Address: akidd@westwardenv.com

9. Project Location:

The project site is located inside the city limits of \_\_\_\_\_.

The project site is located outside the city limits but inside the ETJ (extra-territorial jurisdiction) of New Braunfels.

The project site is not located within any city's limits or ETJ.

10.  The location of the project site is described below. The description provides sufficient detail and clarity so that the TCEQ's Regional staff can easily locate the project and site boundaries for a field investigation.

1870 Wald Rd., New Braunfels, TX 78132

11.  **Attachment A – Road Map.** A road map showing directions to and the location of the project site is attached. The project location and site boundaries are clearly shown on the map.

12.  **Attachment B - USGS / Edwards Recharge Zone Map.** A copy of the official 7 ½ minute USGS Quadrangle Map (Scale: 1" = 2000') of the Edwards Recharge Zone is attached. The map(s) clearly show:

Project site boundaries.

USGS Quadrangle Name(s).

Boundaries of the Recharge Zone (and Transition Zone, if applicable).

Drainage path from the project site to the boundary of the Recharge Zone.

13.  **The TCEQ must be able to inspect the project site or the application will be returned.**

Sufficient survey staking is provided on the project to allow TCEQ regional staff to locate

the boundaries and alignment of the regulated activities and the geologic or manmade features noted in the Geologic Assessment.

Survey staking will be completed by this date: The existing site is fenced.

**Attachment C – Project Description.** Attached at the end of this form is a detailed narrative description of the proposed project. The project description is consistent throughout the application and contains, at a minimum, the following details:

- Area of the site
- Offsite areas
- Impervious cover
- Permanent BMP(s)
- Proposed site use
- Site history
- Previous development
- Area(s) to be demolished

14. Existing project site conditions are noted below:

- Existing commercial site
- Existing industrial site
- Existing residential site
- Existing paved and/or unpaved roads
- Undeveloped (Cleared)
- Undeveloped (Undisturbed/Uncleared)
- Other: \_\_\_\_\_

### ***Prohibited Activities***

15.  I am aware that the following activities are prohibited on the Recharge Zone and are not proposed for this project:

- (1) Waste disposal wells regulated under 30 TAC Chapter 331 of this title (relating to Underground Injection Control);
- (2) New feedlot/concentrated animal feeding operations, as defined in 30 TAC §213.3;
- (3) Land disposal of Class I wastes, as defined in 30 TAC §335.1;
- (4) The use of sewage holding tanks as parts of organized collection systems; and
- (5) New municipal solid waste landfill facilities required to meet and comply with Type I standards which are defined in §330.41(b), (c), and (d) of this title (relating to Types of Municipal Solid Waste Facilities).
- (6) New municipal and industrial wastewater discharges into or adjacent to water in the state that would create additional pollutant loading.

16.  I am aware that the following activities are prohibited on the Transition Zone and are not proposed for this project:

- (1) Waste disposal wells regulated under 30 TAC Chapter 331 (relating to Underground Injection Control);
- (2) Land disposal of Class I wastes, as defined in 30 TAC §335.1; and
- (3) New municipal solid waste landfill facilities required to meet and comply with Type I standards which are defined in §330.41 (b), (c), and (d) of this title.

### ***Administrative Information***

17. The fee for the plan(s) is based on:

- For a Water Pollution Abatement Plan or Modification, the total acreage of the site where regulated activities will occur.
- For an Organized Sewage Collection System Plan or Modification, the total linear footage of all collection system lines.
- For a UST Facility Plan or Modification or an AST Facility Plan or Modification, the total number of tanks or piping systems.
- A request for an exception to any substantive portion of the regulations related to the protection of water quality.
- A request for an extension to a previously approved plan.

18.  Application fees are due and payable at the time the application is filed. If the correct fee is not submitted, the TCEQ is not required to consider the application until the correct fee is submitted. Both the fee and the Edwards Aquifer Fee Form have been sent to the Commission's:

- TCEQ cashier **ePay**
- Austin Regional Office (for projects in Hays, Travis, and Williamson Counties)
- San Antonio Regional Office (for projects in Bexar, Comal, Kinney, Medina, and Uvalde Counties)

19.  Submit one (1) original and one (1) copy of the application, plus additional copies as needed for each affected incorporated city, groundwater conservation district, and county in which the project will be located. The TCEQ will distribute the additional copies to these jurisdictions. The copies must be submitted to the appropriate regional office.

20.  No person shall commence any regulated activity until the Edwards Aquifer Protection Plan(s) for the activity has been filed with and approved by the Executive Director.

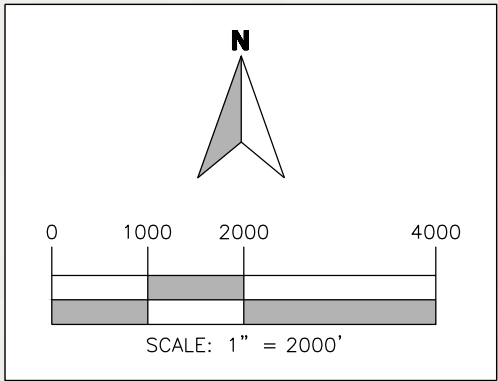

SHEET NO.:  
**1**  
OF 1

IMAGE: BING MAPS	
ISSUE DATE:	02/20/2024
DRAWN BY:	AK
CHECKED BY:	CJF
SCALE: 1" =	2000'
JOB NO.:	10101-061

<b>ROAD MAP</b>			
AST PLAN			
BRAUNTEX MATERIALS, INC.			
NEW BRAUNFELS, COMAL COUNTY, TEXAS			
REV.	DESCRIPTION	BY	DATE

THIS PRODUCT IS FOR INFORMATIONAL PURPOSES AND MAY NOT HAVE BEEN PREPARED FOR OR BE SUITABLE FOR LEGAL, ENGINEERING, OR SURVEYING PURPOSES. IT DOES NOT REPRESENT AN ON-THE-GROUND SURVEY AND REPRESENTS ONLY THE APPROXIMATE RELATIVE LOCATION OF PROPERTY BOUNDARIES.

**WESTWARD**

Environmental. Engineering. Natural Resources.

P.O. Box 2205 Boerne, Texas 78006  
 (830) 249-8284 Fax: (830) 249-0221  
 TBPE REG. NO.: F-4524  
 TBPB REG. NO.: 50112



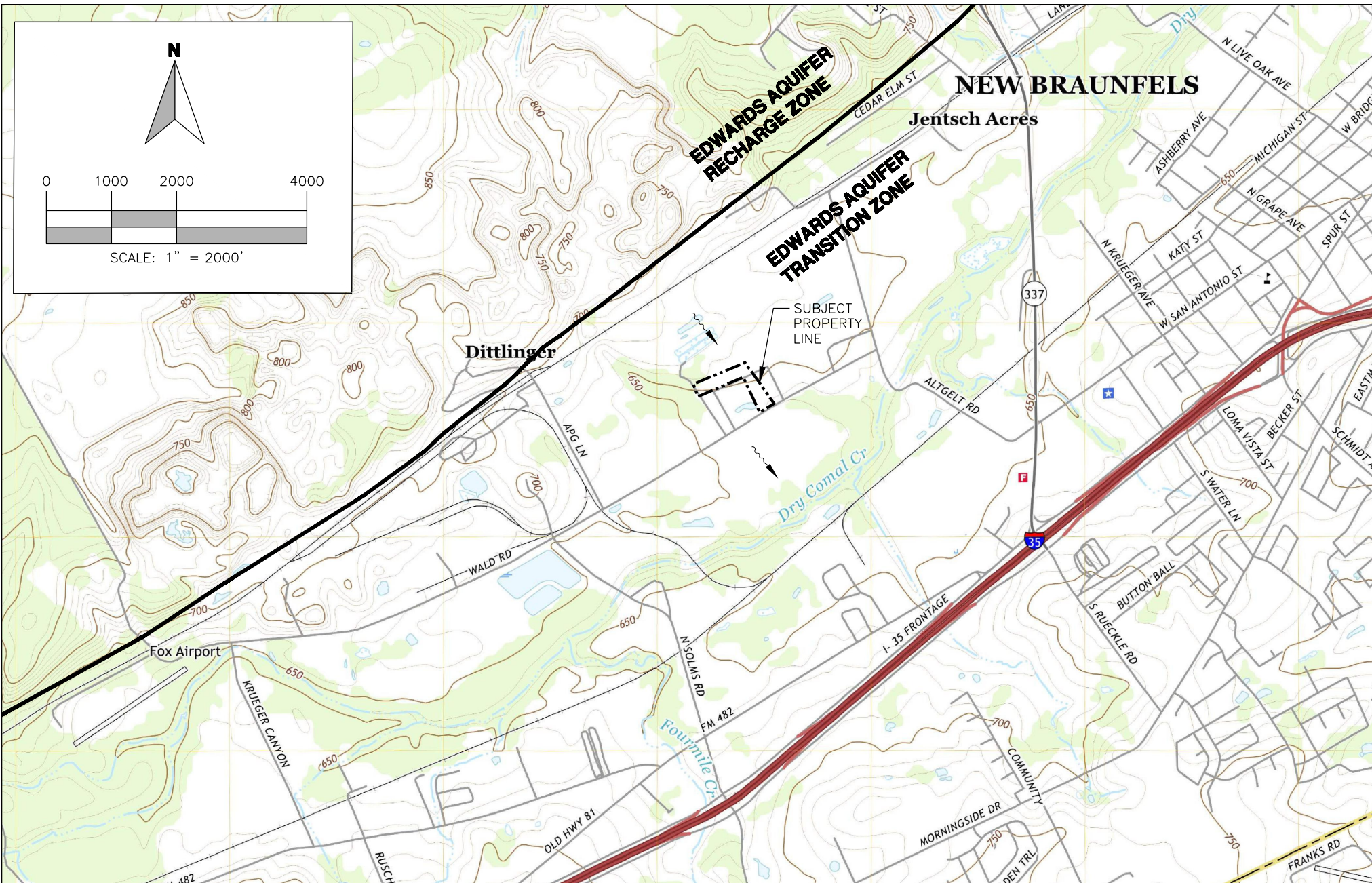

SHEET NO.: <b>1</b> OF 1	IMAGE:	USGS NEW BRAUNFELS WEST
	ISSUE DATE:	02/20/2024
	DRAWN BY:	AK
	CHECKED BY:	CJF
	SCALE:	1" = 2000'
	JOB NO.:	10101-061

<b>USGS MAP</b>			
AST PLAN			
BRAUNTEX MATERIALS, INC.			
NEW BRAUNFELS, COMAL COUNTY, TEXAS			
REV.	DESCRIPTION	BY	DATE

THIS PRODUCT IS FOR INFORMATIONAL PURPOSES AND MAY NOT HAVE BEEN PREPARED FOR OR BE SUITABLE FOR LEGAL, ENGINEERING, OR SURVEYING PURPOSES. IT DOES NOT REPRESENT AN ON-THE-GROUND SURVEY AND REPRESENTS ONLY THE APPROXIMATE RELATIVE LOCATION OF PROPERTY BOUNDARIES.

**WESTWARD**

Environmental. Engineering. Natural Resources.

P.O. Box 2205 Boerne, Texas 78006  
 (830) 249-8284 Fax: (830) 249-0221  
 TBPE REG. NO.: F-4524  
 TBPB REG. NO.: 50112

**Brauntex Materials, Inc.**  
**Brauntex Truck Shop**

**General Information Form (TCEQ-0587)**  
**Attachment C**

**Project Description**

This application for Modification to an Aboveground Storage Tank (AST) Plan has been prepared on behalf of Brauntex Materials, Inc. for the Brauntex Truck Shop. The existing 6.53 acre project site is located at 1870 Wald Road, in New Braunfels, Comal County, Texas.

The site is located on the Transition Zone and there is an existing approved AST Plan for this site, dated June 20, 2002 (EAPP Program ID No. 13-02042601) which authorizes one tank at this site; there are no proposed changes to existing AST 1. The AST Plan is being modified to add eight tanks (numbered 2-9):

AST #	Size (gals)	Substance stored	Location
1 (existing)	10,000	Diesel	Northeast corner of project site, along entrance road
2	400	Maintenance oil	Double-walled tank adjacent to shop
3	400	Maintenance oil	Double-walled tank adjacent to shop
4	400	Maintenance oil	Double-walled tank adjacent to shop
5	400	Maintenance oil	Double-walled tank adjacent to shop
6	400	Maintenance oil	Double-walled tank adjacent to shop
7	400	Maintenance oil	Double-walled tank adjacent to shop
8	275	Maintenance oil	Double-walled tank inside shop
9	10,000	Diesel	Double-walled tank along site road

ASTs 2-7 will be double-walled steel storage tanks and will sit on a curbed concrete pad, which will provide secondary containment for associated hose reels and dispensing nozzles. AST 8 will be a double-walled steel storage tank located inside the shop, within a shallow metal pan which will provide secondary containment for its hose reel and dispensing nozzle. AST 9 will be a double-walled steel tank with double-walled piping specified for filling and dispensing. Since the project is on the Transition Zone, there is no requirement for a Water Pollution Abatement Plan (WPAP); Brauntex Materials, Inc. does maintain a Stormwater Pollution Prevention Plan (SWPPP) for this site.

The Brauntex Truck Shop has been operating for several years as an industrial area containing a truck shop/equipment maintenance area; the natural areas have already been disturbed/paved.

The drainage patterns of the site will not change, and no soil stabilization measures are necessary. Several of the attachments relating to stormwater BMPs (Temporary Stormwater Section Attachments C, D, E, F, G, H, I, and J) are not applicable to this project. There will be no grading activities as a result of this plan modification that will disturb soils, therefore temporary stormwater BMPs are not necessary.

**Brauntex Materials, Inc.**  
**Brauntex Truck Shop**

A geologic assessment (GA), was performed on February 15, 2024, and is included in this report. The GA identified one sensitive manmade feature on the project site which is a well, located more than 150-feet away from the existing diesel tank onsite.



BRAUNTEX MATERIALS, INC.

GEOLOGIC ASSESSMENT

BRAUNTEX TRUCK SHOP  
1870 WALD RD  
NEW BRAUNFELS, TEXAS 78132  
COMAL COUNTY

Submitted to: TCEQ Region 11, Austin

Prepared By:



Boerne, Texas  
830-249-8284

Date: February 2024  
Project No. 10101-061  
-JG-

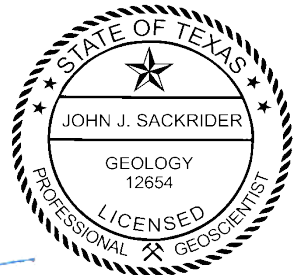

Signature: 

John J. Sackrider, P.G. - License No. 12654  
TX PG Firm No. 50112

Date: 2/23/2024



# Article I. Geologic Assessment

## Texas Commission on Environmental Quality

For Regulated Activities on The Edwards Aquifer Recharge/transition Zones and Relating to 30 TAC §213.5(b)(3), Effective June 1, 1999

**To ensure that the application is administratively complete, confirm that all fields in the form are complete, verify that all requested information is provided, consistently reference the same site and contact person in all forms in the application, and ensure forms are signed by the appropriate party.**

**Note: Including all the information requested in the form and attachments contributes to more streamlined technical reviews.**

### Section 1.01 Signature

To the best of my knowledge, the responses to this form accurately reflect all information requested concerning the proposed regulated activities and methods to protect the Edwards Aquifer. My signature certifies that I am qualified as a geologist as defined by 30 TAC Chapter 213.

Print Name of Geologist:

Telephone: 830-249-8284

John J. Sackrider, P.G. #12654

Fax: 830-249-0221

Date: 2/23/2024

Representing: Westward Environmental, Inc., TBPG Registered Geoscience Firm 50012  
(Name of Company and TBPG or TBPE registration number)

Signature of Geologist:

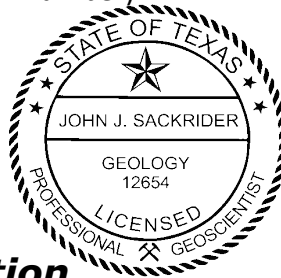
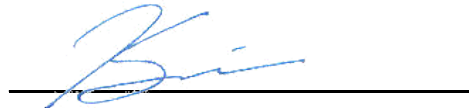

Regulated Entity Name: Brauntex Truck Shop

### Section 1.02 Project Information

1. Date(s) Geologic Assessment was performed: February 15, 2024

2. Type of Project:

WPAP  
 SCS

AST  
 UST

3. Location of Project:

Recharge Zone  
 Transition Zone  
 Contributing Zone within the Transition Zone

4.  **Attachment A - Geologic Assessment Table.** Completed Geologic Assessment Table (Form TCEQ-0585-Table) is attached.
5.  Soil cover on the project site is summarized in the table below and uses the SCS Hydrologic Soil Groups\* (Urban Hydrology for Small Watersheds, Technical Release No. 55, Appendix A, Soil Conservation Service, 1986). If there is more than one soil type on the project site, show each soil type on the site Geologic Map or a separate soils map.

**Article II. Table 1 - Soil Units, Infiltration Characteristics and Thickness**

Soil Name	Group*	Thickness(feet)
ByA	D	> 6
KrB	C	> 6
Tn	D	> 6

*\* Soil Group Definitions (Abbreviated)*

- A. *Soils having a high infiltration rate when thoroughly wetted.*
- B. *Soils having a moderate infiltration rate when thoroughly wetted.*
- C. *Soils having a slow infiltration rate when thoroughly wetted.*
- D. *Soils having a very slow infiltration rate when thoroughly wetted.*

6.  **Attachment B – Stratigraphic Column.** A stratigraphic column showing formations, members, and thicknesses is attached. The outcropping unit, if present, should be at the top of the stratigraphic column. Otherwise, the uppermost unit should be at the top of the stratigraphic column.
7.  **Attachment C – Site Geology.** A narrative description of the site specific geology including any features identified in the Geologic Assessment Table, a discussion of the potential for fluid movement to the Edwards Aquifer, stratigraphy, structure(s), and karst characteristics is attached.
8.  **Attachment D – Site Geologic Map(s).** The Site Geologic Map must be the same scale as the applicant's Site Plan. The minimum scale is 1": 400'  
 Applicant's Site Plan Scale: 1" = 200'  
 Site Geologic Map Scale: 1" = 200'  
 Site Soils Map Scale (if more than 1 soil type): 1" = 200'
9. Method of collecting positional data:
  - Global Positioning System (GPS) technology.
  - Other method(s). Please describe method of data collection: \_\_\_\_\_

10.  The project site and boundaries are clearly shown and labeled on the Site Geologic Map.
11.  Surface geologic units are shown and labeled on the Site Geologic Map.
12.  Geologic or manmade features were discovered on the project site during the field investigation. They are shown and labeled on the Site Geologic Map and are described in the attached Geologic Assessment Table.
- Geologic or manmade features were not discovered on the project site during the field investigation.
13.  The Recharge Zone boundary is shown and labeled, if appropriate.
14. All known wells (test holes, water, oil, unplugged, capped and/or abandoned, etc.): If applicable, the information must agree with Item No. 20 of the WPAP Application Section.
- There are 1 (#) wells present on the project site and the locations are shown and labeled. (Check all of the following that apply.)
- The wells are not in use and have been properly abandoned.
- The wells are not in use and will be properly abandoned.
- The well is in use and comply with 16 TAC Chapter 76.
- There are no wells or test holes of any kind known to exist on the project site.

### ***Section 2.01 Administrative Information***

15.  Submit one (1) original and one (1) copy of the application, plus additional copies as needed for each affected incorporated city, groundwater conservation district, and county in which the project will be located. The TCEQ will distribute the additional copies to these jurisdictions. The copies must be submitted to the appropriate regional office.

## **Attachment A**

### **Geologic Assessment Table (Form TCEQ-0585)**



GEOLOGIC ASSESSMENT TABLE			PROJECT NAME: BRAUNTEX TRUCK SHOP																	
LOCATION			FEATURE CHARACTERISTICS										EVALUATION		PHYSICAL SETTING					
1A	1B *	1C*	2A	2B	3	4			5	5A	6	7	8A	8B	9	10		11		12
FEATURE ID	LATITUDE	LONGITUDE	FEATURE TYPE	POINTS	FORMATION	DIMENSIONS (FEET)			TREND (DEGREES)	DIP (DEGREES)	DENSITY (NO/FT)	APERTURE (FEET)	INFILL	RELATIVE INFILTRATION RATE	TOTAL	SENSITIVITY		CATCHMENT AREA (ACRES)		TOPOGRAPHY
						X	Y	Z								<40	≥40	<1.6	≥1.6	
S-1	29.681234	-98.171117	CD	5	Qt	383	78	8	N/A				F	5	10	X		X		Hillside
S-2	29.680626	-98.168397	MB	30	Qt	0.5	unknown		N/A				N	35	65		X	X		Floodplain

\* DATUM: NAD 83

2A TYPE	TYPE	2B POINTS
C	Cave	30
SC	Solution cavity	20
SF	Solution-enlarged fracture(s)	20
F	Fault	20
O	Other natural bedrock features	5
MB	Manmade feature in bedrock	30
SW	Swallow hole	30
SH	Sinkhole	20
CD	Non-karst closed depression	5
Z	Zone, clustered or aligned features	30

8A INFILLING
N None, exposed bedrock
C Coarse - cobbles, breakdown, sand, gravel
O Loose or soft mud or soil, organics, leaves, sticks, dark colors
F Fines, compacted clay-rich sediment, soil profile, gray or red colors
V Vegetation. Give details in narrative description
FS Flowstone, cements, cave deposits
X Other materials

12 TOPOGRAPHY
Cliff, Hilltop, Hillside, Drainage, Floodplain, Streambed

I have read, I understood, and I have followed the Texas Commission on Environmental Quality's Instructions to Geologists. The information presented here complies with that document and is a true representation of the conditions observed in the field.

My signature certifies that I am qualified as a geologist as defined by 30 TAC Chapter 213.

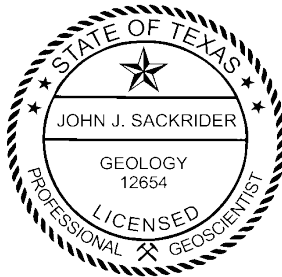
Date 2/23/2024

**Attachment B**

**Stratigraphic Column**

**Generalized Stratigraphic Column – Comal County**

Hydrogeologic subdivision		Group formation or member	Hydrologic Function	Thickness (feet)	Lithology	Cavem development	Porosity / permeability type		
Quaternary		Alluvium	AQ	0-30	Siltstone to sandstone	None	High porosity/high permeability		
		Fluviatile terrace deposits	AQ where saturated	0-45	Coarse gravel, sand, and silt	None	High porosity/high permeability		
Upper Cretaceous	Upper confining units	Navarro and Taylor Groups, undivided	CU	600	Clay, chalky limestone	None	Low porosity / low permeability		
		Austin Group	CU; rarely AQ	130-150	White to gray limestone	None	Low porosity; rare water production from fractures / low permeability		
		Eagle Ford Group	CU	30-50	Brown, flaggy shale and argillaceous limestone	None	Primary porosity lost / low permeability		
		Buda Limestone	CU	40-50	Buff, light gray, dense mudstone	Minor surface karst	Low porosity / low permeability		
		Del Rio Clay	CU	40-50	Blue-green to yellow-brown clay	None	Low porosity / low permeability		
Lower Cretaceous	I	Georgetown Formation	Karst AQ; not karst CU		Reddish-brown, gray to light tan marly limestone	None	Low porosity / low permeability		
	Edwards Aquifer	Edwards Group	F M	Cyclic & marine members undivided	AQ	89-90	Mudstone to packstone; miliolid grainstone; chert	Many sub-surface	Laterally extensive; water yielding
				Leached & collapsed members	AQ	70-90	Crystalline limestone; mudstone to grainstone; chert collapsed breccia	Extensive lateral development; large rooms	Majority not fabric / one of the most permeable
			Person	Regional dense members	CU	20-24	Dense, argillaceous mudstone	Very few; only vertical fracture enlargement	Not fabric / low permeability; vertical barrier
				F M	Grainstone member	AQ	50-60	Miliolid grainstone; mudstone to wackestone; chert	Few
		Kirschberg evaporite member	AQ		50-60	Highly altered crystalline limestone; chalky mudstone; chert	Probably extensive cave development	Majority fabric / one of the most permeable	
		Kainer	Dolomitic member	AQ	110-130	Mudstone to grainstone; crystalline limestone; chert	Caves related to structure or bedding planes	Mostly not fabric; some bedding plane fabric / water yielding	
			Basal nodular member	Karst AQ; not karst CU	50-60	Shaly, nodular limestone; mudstone and miliolid grainstone	Large lateral caves at surface	Fabric; stratigraphically controlled/ large conduit flow at surface; no permeability in subsurface	
		Lower confining unit	Upper member of the Glen Rose Limestone	CU; evaporite beds AQ	350-1150	Yellowish tan, thinly bedded limestone and marl. Thick massive limestone bed at base.	Some surface cave development.	Some water production at evaporite beds / relatively impermeable	
	Lower Member of the Glen Rose Limestone								

 Indicates units observed at the surface of the Site.

## **Attachment C**

### **Site Geology (Geologic Narrative)**

## Geologic Narrative

### 1.0 PURPOSE

Westward Environmental, Inc. (WESTWARD) was retained by Brauntex Materials, Inc. (Client) to prepare a Geologic Assessment (GA) on their ~6.53-acre Brauntex Truck Shop (Site). This GA was prepared as a required attachment to an Aboveground Storage Tank (AST) Plan Modification application for the Site as required by the Texas Commission of Environmental Quality (TCEQ).

### 2.0 REGULATORY GUIDANCE

#### Title 30, Chapter 213 of the Texas Administrative Code

This report was prepared in accordance with *Instructions for Geologists for Geologic Assessments on the Edwards Aquifer Recharge/Transition Zones (TCEQ-0585 (Rev. 10-01-04))* and will be reviewed pursuant to Title 30, Chapter 213 of the Texas Administrative Code.

### 3.0 PROJECT LOCATION

The Site address is listed as 1870 Wald Rd., New Braunfels, Texas. The is located approximately 1.25 miles west of the intersection of Interstate 35 and Loop 337 just southwest of New Braunfels in Comal County. The Site is located over the Edwards Aquifer Transition Zone (EATZ).

### 4.0 METHODOLOGY

As part of the GA, WESTWARD performed a desktop review of selected published information. WESTWARD also conducted a field investigation in accordance with *TCEQ-0585 (Rev. 10-01-04)*.

#### 4.1 Desktop Review

WESTWARD conducted a review of aerial imagery, the University of Texas Bureau of Economic Geology (BEG) Geologic Atlas of Texas (GAT) San Antonio Sheet, applicable U.S. Geological Survey (USGS) Topographic quadrangle(s) and geospatial dataset(s), the Texas Natural Resources Information System (TNRIS), the Texas Water Development Board's Water Data Interactive Groundwater Data Viewer (TWDB Viewer), the Railroad Commission of Texas (RRC), and the U.S. Department of Agriculture (USDA) National Resource Conservation Service (NRCS) Web Soil Survey prior to the field investigation.

#### 4.2 Field Investigation

A field investigation was performed at the Site by John J. Sackrider, P.G. (TBPG Lic. No. 12654) on February 15, 2024. Field transects of the Site were walked in accordance with TCEQ-0585 (rev. 10-01-04).

## 5.0 DESKTOP REVIEW

The desktop review was utilized for preliminary planning of the field investigation. The accuracy of the desktop review was limited by the accessibility, scale, and age of the data available.

### 5.1 Published Surface Geology

A review of published geologic maps revealed one unit, the Quaternary-aged Fluvial terrace deposits (Qt), mapped at the surface of the Site. The early Cretaceous-aged Edwards Limestone (Ked) is located approximately 500 ft. just to the northwest of the Site. The Qt is shown on the Site Geologic Map (Attachment D).

### 5.2 Published Structure

The Site is located within the Balcones Fault Zone (BFZ). There are no mapped faults within the Site, but the closest published fault is mapped approximately 2.25 miles to the northwest of the Site. This fault has an approximate trend of 44° and is referenced here to determine the dominant fault trend range of this Site. For the purposes of this GA, the dominant fault trend range is between 29° and 59°.

### 5.3 Karst Features

The desktop review did not reveal karst features within the Site.

### 5.4 Non-karst & Manmade Features

The desktop review of aerial imagery did not reveal non-karst or manmade features within the Site boundaries. A review of the TWDB Viewer did not reveal any onsite groundwater wells at the Site.

### 5.5 Soils

Three (3) soil units were identified on the Site through the NRCS Web Soil Survey. They are detailed below as well as included on the Geologic Assessment Form TCEQ-0585 (Rev. 02-11-15). A Site Soils Map is included in Attachment D.

<b>Published Soil Unit Descriptions</b>			
<i>Soil Name</i>	<i>Group</i>	<i>Thickness (Feet)</i>	<i>Description</i>
Branyon clay (ByA), 0 to 1 percent slopes	D	> 6	More than 80 inches to restrictive feature, moderately well drained, very low to moderately low (0.00 to 0.06 in/hr) Ksat capacity
Krum clay (KrB), 1 to 3 percent slopes	C	> 6	More than 80 inches to restrictive feature, well drained, moderately low to moderately high (0.06 to 0.20 in/hr) Ksat capacity
TInn clay (Tn), 0 to 1 percent slopes, frequently flooded	D	> 6	More than 80 inches to restrictive feature, moderately well drained, very low to moderately low (0.00 to 0.06 in/hr) Ksat capacity

## 6.0 FIELD INVESTIGATION

The field investigation was performed on February 15, 2024 by John J. Sackrider, P.G. to verify the presence or absence of recharge features identified in the desktop review and to identify recharge features not found during the desktop review. Field reconnaissance was performed in accordance with the *TCEQ-0585-Instructions (Rev. 10-1-04)*.

### 6.1 Surface Geology

The Site has been heavily disturbed and is almost fully developed. Undeveloped areas contain dense vegetation with a thick soil profile, making confirmation of the mapped surface geology difficult to interpret. Observations at the Site are consistent with published descriptions of the Qt.

### 6.2 Structure

There were no faults identified nor evidence of faulting observed in the Site during the field investigation.

### 6.3 Karst Features

Karst features were not identified during the field investigation.

### 6.4 Non-karst & Manmade Features

One (1) non-karst closed depression, S-1, and one (1) manmade feature in bedrock, S-2, were identified in the Site and recorded during the field investigation. Feature S-2 is rated sensitive.

### 6.5 Feature Descriptions

#### S-1 (CD)

#### Not Sensitive

Feature S-1 is a non-karst closed depression located along the northwest portion of the Site boundary. While most of the feature extends out of the Site boundary, it is included here because a portion of the feature lies within the Site. It is a pond that measures approximately 383 ft. x 78 ft. x 8 ft. and was holding water at the time of field investigation. The catchment area of the feature is less than 1.6 acres and the interpreted probability of rapid infiltration is low. This feature is rated not sensitive.

#### S-2 (MB)

#### Sensitive

Feature S-2 is a well that is classified as a manmade feature in bedrock and located within the FEMA 100-year floodplain. It is open to the air and has a steel casing that measures approximately 0.5 ft. in diameter. The depth is unknown. The catchment area of the feature is less than 1.6 acres but due to the feature being open and located within the floodplain, the interpreted probability of rapid infiltration is high. This feature is rated sensitive.

**SELECT PHOTOGRAPHS**



S-1: Pond classified as a nonkarst closed depression.

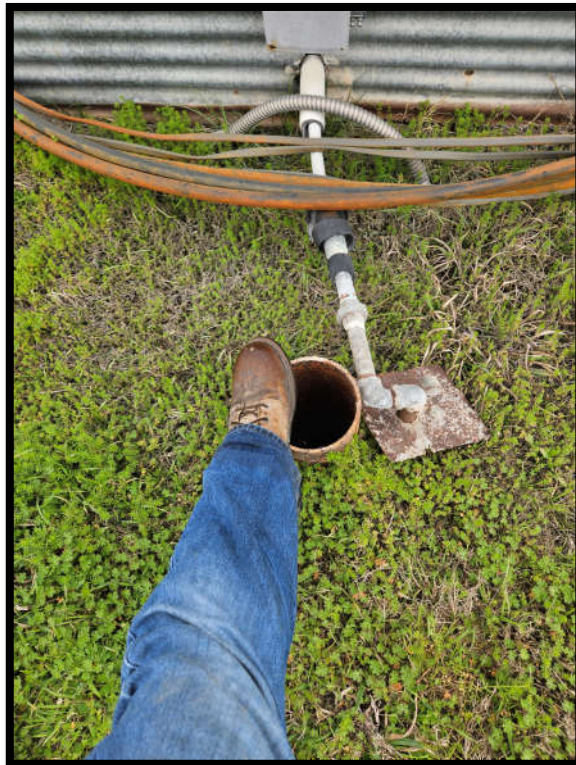

S-2: Well classified as a manmade feature in bedrock.



**Attachment D**

**Site Geologic Map  
Site Soils Map**

The entire mapped area is within the Edwards Aquifer Transition Zone.



**Legend**

- Project Boundary
  - GA Features
  - FEMA Floodplain
  - Published Geology (GDT\*)
  - Qt - Fluvial terrace deposits
- \*Geologic Database of Texas*

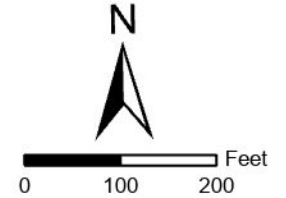

SHEET NO.: <b>001</b> OF 002	IMAGE: ESRI WORLD IMAGERY	
	ISSUE DATE:	02/23/2023
	DRAWN BY:	JG
	CHECKED BY:	JJS
	SCALE: 1" =	200'
	JOB NO.:	10101-061

<b>SITE GEOLOGIC MAP</b>			
BRAUNTEX TRUCK SHOP BRAUNTEX MATERIALS, INC. NEW BRAUNFELS, COMAL COUNTY, TEXAS			
REV.	DESCRIPTION	BY	DATE

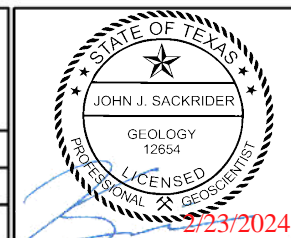

**WESTWARD**  
Environmental, Engineering, Natural Resources.  
P.O. Box 2205, Boerne, Texas 78006  
(830) 249-8284 Fax: (830) 249-0221  
TBPE REG. NO.: F-4524  
TBPG REG. NO.: 50112





**Legend**

- Project Boundary
- GA Features

Published Soils (NRCS\*)

- ByA - Branyon clay, 0-1% slopes
- KrB - Krum clay, 1-3% slopes
- Tn - Tinn clay, 0-1% slopes

*\*Natural Resources Conservation Service*

N

0 100 200 Feet

<b>002</b> SHEET NO. OF 002	IMAGE: ESRI WORLD IMAGERY	
	ISSUE DATE:	02/23/2023
	DRAWN BY:	JG
	CHECKED BY:	JJS
	SCALE: 1" =	200'
	JOB NO.:	10101-061

<b>SITE SOILS MAP</b>			
BRAUNTEX TRUCK SHOP BRAUNTEX MATERIALS, INC. NEW BRAUNFELS, COMAL COUNTY, TEXAS			
REV.	DESCRIPTION	BY	DATE

JOHN J. SACKRIDER  
GEOLOGY  
12654  
LICENSED PROFESSIONAL GEOSCIENTIST

2/23/2024

**WESTWARD**  
Environmental, Engineering, Natural Resources.  
P.O. Box 2205, Boerne, Texas 78006  
(830) 249-8284 Fax: (830) 249-0221  
TBPE REG. NO.: F-4524  
TBPG REG. NO.: 50112

# Modification of a Previously Approved Plan

## Texas Commission on Environmental Quality

for Regulated Activities on the Edwards Aquifer Recharge Zone and Transition Zone and Relating to 30 TAC 213.4(j), Effective June 1, 1999

**To ensure that the application is administratively complete, confirm that all fields in the form are complete, verify that all requested information is provided, consistently reference the same site and contact person in all forms in the application, and ensure forms are signed by the appropriate party.**

**Note: Including all the information requested in the form and attachments contributes to more streamlined technical reviews.**

## Signature

To the best of my knowledge, the responses to this form accurately reflect all information requested concerning the proposed regulated activities and methods to protect the Edwards Aquifer. This request for a **Modification of a Previously Approved Plan** is hereby submitted for TCEQ review and executive director approval. The request was prepared by:

Print Name of Engineer/Agent: Andrea Kidd, P.E.

TX License No. 132541 | TX Firm No. 4524

Date: 3/4/2024

Signature of Engineer/Agent:

*Andrea Kidd*



## Project Information

1. Current Regulated Entity Name: Brauntex Truck Shop  
Original Regulated Entity Name: Southern Tank Transport  
Regulated Entity Number(s) (RN): 100853555  
Edwards Aquifer Protection Program ID Number(s): 13-02042601  
 The applicant has not changed and the Customer Number (CN) is: 600618581  
 The applicant or Regulated Entity has changed. A new Core Data Form has been provided.
2.  **Attachment A: Original Approval Letter and Approved Modification Letters.** A copy of the original approval letter and copies of any modification approval letters are attached.

3. A modification of a previously approved plan is requested for (check all that apply):
- Physical or operational modification of any water pollution abatement structure(s) including but not limited to ponds, dams, berms, sewage treatment plants, and diversionary structures;
  - Change in the nature or character of the regulated activity from that which was originally approved or a change which would significantly impact the ability of the plan to prevent pollution of the Edwards Aquifer;
  - Development of land previously identified as undeveloped in the original water pollution abatement plan;
  - Physical modification of the approved organized sewage collection system;
  - Physical modification of the approved underground storage tank system;
  - Physical modification of the approved aboveground storage tank system.
4.  Summary of Proposed Modifications (select plan type being modified). If the approved plan has been modified more than once, copy the appropriate table below, as necessary, and complete the information for each additional modification.

<b><i>WPAP Modification</i></b>	<b><i>Approved Project</i></b>	<b><i>Proposed Modification</i></b>
<b><i>Summary</i></b>		
Acres	_____	_____
Type of Development	_____	_____
Number of Residential Lots	_____	_____
Impervious Cover (acres)	_____	_____
Impervious Cover (%)	_____	_____
Permanent BMPs	_____	_____
Other	_____	_____

<b><i>SCS Modification</i></b>	<b><i>Approved Project</i></b>	<b><i>Proposed Modification</i></b>
<b><i>Summary</i></b>		
Linear Feet	_____	_____
Pipe Diameter	_____	_____
Other	_____	_____

<b>AST Modification Summary</b>	<b>Approved Project EAPP ID 1302042601</b>	<b>After Proposed Modification</b>
Number of ASTs	<u>1</u>	<u>9</u>
Volume of ASTs	<u>10,000</u>	<u>22,675</u>
Other	_____	_____

<b>UST Modification Summary</b>	<b>Approved Project</b>	<b>Proposed Modification</b>
Number of USTs	_____	_____
Volume of USTs	_____	_____
Other _____	_____	_____

5.  **Attachment B: Narrative of Proposed Modification.** A detailed narrative description of the nature of the proposed modification is attached. It discusses what was approved, including any previous modifications, and how this proposed modification will change the approved plan.
  
6.  **Attachment C: Current Site Plan of the Approved Project.** A current site plan showing the existing site development (i.e., current site layout) at the time this application for modification is attached. A site plan detailing the changes proposed in the submitted modification is required elsewhere.
  - The approved construction has not commenced. The original approval letter and any subsequent modification approval letters are included as Attachment A to document that the approval has not expired.
  - The approved construction has commenced and has been completed. Attachment C illustrates that the site was constructed as approved.
  - The approved construction has commenced and has been completed. Attachment C illustrates that the site was **not** constructed as approved.
  - The approved construction has commenced and has **not** been completed. Attachment C illustrates that, thus far, the site was constructed as approved.
  - The approved construction has commenced and has **not** been completed. Attachment C illustrates that, thus far, the site was **not** constructed as approved.
  
7.  The acreage of the approved plan has increased. A Geologic Assessment has been provided for the new acreage.
  - Acreage has not been added to or removed from the approved plan.
  
8.  Submit one (1) original and one (1) copy of the application, plus additional copies as needed for each affected incorporated city, groundwater conservation district, and county in which the project will be located. The TCEQ will distribute the additional copies to these jurisdictions. The copies must be submitted to the appropriate regional office.

**Brauntex Materials, Inc.  
Brauntex Truck Shop**

**Modification of a Previously Approved Plan (TCEQ-0590)**

**Attachment A**

**Previous AST Plan Approval Letter**

Robert J. Huston, *Chairman*  
R. B. "Ralph" Marquez, *Commissioner*  
Kathleen Hartnett White, *Commissioner*  
Jeffrey A. Saitas, *Executive Director*

## TEXAS NATURAL RESOURCE CONSERVATION COMMISSION

*Protecting Texas by Reducing and Preventing Pollution*

June 20, 2002

Mr. Phil Henson  
Southern Tank Transport  
1870 Wald Road  
New Braunfels, TX 78132

Re: Edwards Aquifer, Comal County  
NAME OF PROJECT: Southern Tank Transport AST; 1870 Wald Road; New Braunfels, Texas.  
TYPE OF PLAN: Request for Approval of an Aboveground Storage Tank (AST) Facility Plan; 30 Texas Administrative Code (TAC) Chapter 213 Edwards Aquifer  
Edwards Aquifer Protection Program File No. 1841.00

Dear Mr. Henson:

The Texas Natural Resource Conservation Commission (TNRCC) has completed its review of the AST application for the referenced project submitted to the San Antonio Regional Office by Arnulfo Gonzalez, P.E. of e-sol, Environmental Engineering Solutions on behalf of Southern Tank Transport on April 26, 2002. As presented to the TNRCC, the AST Facility Plan proposed in the application was prepared to be in general compliance with the requirements of 30 TAC §213.5(e). Therefore, based on the applicant's concurrence of compliance, the planning materials for construction of the proposed project and pollution abatement measures are hereby approved subject to applicable state rules and the conditions in this approval letter. The applicant or a person affected may file with the chief clerk a motion for reconsideration of the executive director's final action on this Edwards Aquifer protection plan. A motion for reconsideration must be filed no later than 20 days after the date of this approval letter. *This approval expires two (2) years from the date of this letter unless, prior to the expiration date, more than 10 percent of the construction has commenced on the project or an extension of time has been requested.*

### PROJECT DESCRIPTION

The project site is located on the Edwards Aquifer Transition Zone. The proposed AST Facility Plan includes the items listed in the table below.

AST	Gallons	Tank Material	Contents of Tank
1	10,000	Double Wall Steel	Diesel Fuel <sup>1</sup>
Total	10,000		

The applicant has requested an exception to the 150 percent storage capacity requirement for the containment system. The applicant has proposed an alternative method of secondary containment. The described AST will consist of double wall steel construction. The outer steel tank will have inside dimensions of 27 feet 5 inches in length by 93 ½ inches in width by 96 inches in depth, yielding a total containment of 110 percent of the total storage capacity of the inner tank. Any spillage will be directed to a convenient point with the containment structure for collection and recovery.

REPLY TO: REGION 13 • 14250 JUDSON RD. • SAN ANTONIO, TEXAS 78233-4480 • 210/490-3096 • FAX 210/545-4329

P.O. Box 13087 • Austin, Texas 78711-3087 • 512/239-1000 • Internet address: [www.tnrcc.state.tx.us](http://www.tnrcc.state.tx.us)



Mr. Phil Henson  
June 20, 2002  
Page 2

Piping to dispensers or equipment will extend outside the containment structure. The piping will be aboveground. Spill and overflow control for each tank will be provided by an alarm which will be triggered when the tank is 90% full. Additionally, the tank will be equipped with an automatic shut-off that is activated when the tank is 95% full to prevent overflow.

The planned spill response that will take place at the facility is provided in Attachment "E" (enclosed) of the AST Facility Plan application (Response Actions to Spills). In the event of a release or an accumulation of contaminated stormwater, the contained stormwater will be disposed of in accordance with TNRCC requirements.

#### GEOLOGY

An exception to the geologic exception was submitted as part of this application. According to the applicant's representative, the area where the proposed AST's are to be installed is currently developed and there is no surface specific geology available for examination.

The San Antonio Regional Office site inspection of May 21, 2002, revealed that the site is currently developed as described by the geologic assessment exception request and no geologic or manmade features were observed during the investigation.

#### SPECIAL CONDITIONS

Based on the information provided and the site investigation conducted on May 21, 2002, an exception to providing a geologic assessment is granted.

#### STANDARD CONDITIONS

1. Pursuant to §26.136 of the Texas Water Code, any violations of the requirements in 30 TAC Chapter 213 may result in administrative penalties.
2. The owner of the proposed facility shall assure that the storage tank system is installed, operated, and maintained in full compliance with the applicable provisions of 30 TAC §213.5(e) and 30 TAC Chapter 334, and all local, state, and federal regulations.

#### Prior to Commencement of Construction:

3. Within 60 days of receiving written approval of an Edwards Aquifer protection plan, the applicant must submit, to the San Antonio Regional Office, proof of recordation of notice in the county deed records, with the volume and page number(s) of the county deed records of the county in which the property is located. A description of the property boundaries covered by the Edwards Aquifer protection plan shall be included in the deed recordation in the county deed records. A suggested form (TNRCC-0625) that you may use to deed record the approved AST Facility Plan is enclosed.
4. All contractors conducting regulated activities at the referenced project location shall be provided a copy of this notice of approval. At least one complete copy of the approved AST Facility Plan and this notice of approval shall be maintained at the project location until all regulated activities are completed.
5. Prior to commencing construction, the applicant shall submit any modifications to this approved AST Facility Plan required by some other regulating authority or desired by the applicant.
6. Modification to the activities described in the referenced AST Facility Plan, including Attachment "E" of the AST Facility Plan application (Response Actions to Spills), following the date of approval

Mr. Phil Henson

June 20, 2002

Page 3

may require the submittal of an Edwards Aquifer protection plan application to modify this approval. the payment of appropriate fees and all information necessary must be provided for its review and approval prior to initiating construction of the modifications.

7. The applicant must provide written notification of intent to commence construction of the referenced project. Notification must be submitted to the San Antonio Regional Office no later than 48 hours prior to commencement of the regulated activity. Written notification must include the date on which the regulated activity will commence, and the name of the approved plan and file number for the regulated activity, the name of the prime contractor with the name and telephone number of the contact person. The executive director will use the notification to determine if the applicant is eligible for an extension.
8. Temporary erosion and sedimentation (E&S) controls, i.e., silt fences, rock berms, stabilized construction entrances, or other controls described in the approved Edwards Aquifer protection plan, must be installed prior to construction and maintained during construction. Temporary E&S controls may be removed when vegetation is established and the construction area is stabilized. The TNRCC may monitor stormwater discharges from the site to evaluate the adequacy of temporary E&S control measures. Additional controls may be necessary if excessive solids are being discharged from the site.
9. All borings with depths greater than or equal to 20 feet must be plugged with a non-shrink grout from the bottom of the hole to within three (3) feet of the surface. The remainder of the hole must be backfilled with cuttings from the boring. All borings less than 20 feet must be backfilled with cuttings from the boring. All borings must be backfilled or plugged within four (4) days of completion of the drilling operation. Voids may be filled with gravel.

During Construction:

10. During the course of regulated activities related to this project, the applicant or agent shall comply with all applicable provisions of 30 TAC Chapter 213, Edwards Aquifer. The applicant shall remain responsible for the provisions and conditions of this approval until such responsibility is legally transferred to another person or entity.
11. If any sensitive geologic feature (caves, solution cavities, sink holes, etc.) is discovered during construction, all regulated activities near the feature must be suspended immediately. The applicant or agent must immediately notify the San Antonio Regional Office of the discovery of the feature. Regulated activities near the feature may not proceed until the executive director has reviewed and approved the methods proposed to protect the feature and the aquifer from potentially adverse impacts to water quality. The plan must be sealed, signed, and dated by a Texas Licensed Professional Engineer.
12. No wells exist on the site. All water wells, including injection, dewatering, and monitoring wells must be in compliance with the requirements of the Texas Department of Licensing and Regulation under Title 16 TAC Chapter 76 (relating to Water Well Drillers and Pump Installers) and all other locally applicable rules, as appropriate.
13. If sediment escapes the construction site, the sediment must be removed at a frequency sufficient to minimize offsite impacts to water quality (e.g., fugitive sediment in street being washed into surface streams or sensitive features by the next rain). Sediment must be removed from sediment traps or sedimentation ponds not later than when design capacity has been reduced by 50 percent. Litter, construction debris, and construction chemicals shall be prevented from becoming stormwater discharge pollutants.

Mr. Phil Henson  
June 20, 2002  
Page 4

14. The following records shall be maintained and made available to the executive director upon request: the dates when major grading activities occur, the dates when construction activities temporarily or permanently cease on a portion of the site, and the dates when stabilization measures are initiated.
15. Stabilization measures shall be initiated as soon as practicable in portions of the site where construction activities have temporarily or permanently ceased, and construction activities will not resume within 21 days. When the initiation of stabilization measures by the 14th day is precluded by weather conditions, stabilization measures shall be initiated as soon as practicable.

After Completion of Construction:

16. Attachment "E" of the AST Facility Plan application (Response Actions to Spills) shall be located on-site (copy enclosed).
17. In the event of a spill, any spillage will be removed from the containment structure within 24 hours of the spill and disposed of properly. The applicant must comply with 30 TAC Chapter 334, Subchapter D, pertaining to Release Reporting and Corrective Action.
18. During the life of the aboveground storage tank facility, the owner shall comply with all applicable provisions of 30 TAC §213.5(e). Additionally, the owner, Southern Tank Transport shall remain responsible for the provisions and conditions of this approval until such responsibility is legally transferred to another person or entity, upon which that person or entity shall assume all responsibility for provisions and specific conditions of this approval.
19. An "as-built" site plan for the facility shall be drawn to scale and in sufficient detail to depict the specific locations and dimensions of all major components of the storage system. A copy of such "as-built" site plan and construction drawings, as well as operating instructions for all major system components shall be maintained in a secure location at the site of the proposed facility. This information shall be available for examination by TNRCC personnel upon request.

If you have any questions or require additional information, please contact Tom Gutierrez of the Edwards Aquifer Protection Program of the San Antonio Regional Office at 210-403-4025.

Sincerely,



Jeffrey A. Saitas, P.E.  
Executive Director  
Texas Natural Resource Conservation Commission

JAS/TG/eg

Enclosure: Deed Recordation Affidavit, TNRCC Form 0625  
Attachment "E" of AST Facility Plan application (Response Actions to Spills)

cc: Mr. Arnulfo Gonzalez, P.E., e-sol, Environmental Engineering Solutions  
Mr. Tom Hornseth, Comal County  
Mr. Harry Bennett, City of New Braunfels  
Mr. Greg Ellis, Edwards Aquifer Authority  
TNRCC Central Records MC 212

**Brauntex Materials, Inc.  
Brauntex Truck Shop**

**Modification of a Previously Approved Plan (TCEQ-0590)  
Attachment B**

**Narrative of Proposed Modification**

There is currently one 10,000-gallon diesel tank at (existing AST 1) this site authorized by the existing approved AST Plan, dated June 20, 2002 (EAPP Program ID No. 13-02042601); there are no proposed changes to existing AST 1. The project area is in Comal County and is located over the Edwards Transition Zone, where there is no requirement for a Water Pollution Abatement Plan (WPAP).

The AST Plan is being modified to add eight tanks, numbered 2-9.

AST #	Size (gals)	Substance stored	Location
1 (existing)	10,000	Diesel	Double-walled tank at northeast corner of project site, along entrance road
2	400	Maintenance oil	Double-walled tank adjacent to shop
3	400	Maintenance oil	Double-walled tank adjacent to shop
4	400	Maintenance oil	Double-walled tank adjacent to shop
5	400	Maintenance oil	Double-walled tank adjacent to shop
6	400	Maintenance oil	Double-walled tank adjacent to shop
7	400	Maintenance oil	Double-walled tank adjacent to shop
8	275	Maintenance oil	Double-walled tank inside shop
9	10,000	Diesel	Double-walled tank along interior site road

**Total proposed onsite volume = 22, 675 gallons**

ASTs 2-7 will be double-walled storage tanks and will sit on a curbed concrete pad, which will provide secondary containment for associated hose reels and dispensing nozzles. AST 8 will be a double-walled storage tank located inside the shop, within a shallow metal pan which will provide secondary containment for its hose reel and dispensing nozzle. AST 9 will be a double-walled steel tank with double-walled piping specified for filling and dispensing.

No land will be disturbed, no clearing or grading will occur as a result of this AST Plan modification. The drainage patterns of the site will not change under this plan, no soil stabilization measures are necessary, and no additional temporary or permanent BMPs are proposed for this project.

# Aboveground Storage Tank Facility Plan Application

## Texas Commission on Environmental Quality

For Permanent Storage on The Edwards Aquifer Recharge and Transition Zones And Relating to 30 TAC §213.5(e), Effective June 1, 1999

*To ensure that the application is administratively complete, confirm that all fields in the form are complete, verify that all requested information is provided, consistently reference the same site and contact person in all forms in the application, and ensure forms are signed by the appropriate party.*

*Note: Including all the information requested in the form and attachments contributes to more streamlined technical reviews.*

## Signature

To the best of my knowledge, the responses to this form accurately reflect all information requested concerning the proposed regulated activities and methods to protect the Edwards Aquifer. This **Aboveground Storage Tank Facility Plan Application** is hereby submitted for TCEQ review and Executive Director approval. The application was prepared by:

Print Name of Engineer/Agent: Andrea Kidd, P.E.

TX License No. 132541 | TX Firm No. 4524

Date: 3/4/2024

Signature of Engineer/Agent :



Regulated Entity Name: Brauntex Truck Shop

## Aboveground Storage Tank (AST) Facility Information

1. Tanks and substance stored:

**Table 1 - Tank and Substance Storage**

<i>AST Number</i>	<i>Size (Gallons)</i>	<i>Substance to be Stored</i>	<i>Tank Material</i>
1 (existing)	10,000	Diesel	Double-walled steel
2	400	Maintenance Oil	Double-walled poly within steel UL2258
3	400	Maintenance Oil	Double-walled poly within steel UL2258

<i>AST Number</i>	<i>Size (Gallons)</i>	<i>Substance to be Stored</i>	<i>Tank Material</i>
4	400	Maintenance Oil	Double-walled poly within steel UL2258
5	400	Maintenance Oil	Double-walled poly within steel UL2258
6	400	Maintenance Oil	Double-walled poly within steel UL2258
7	400	Maintenance Oil	Double-walled poly within steel UL2258
8	275	Maintenance Oil	Double-walled poly within steel UL2258
9	10,000	Diesel	Double-walled steel

**Total x 1.5 = 34,013 Gallons**

2.  The AST will be placed within a containment structure that is sized to capture one and one-half (1 1/2) times the storage capacity of the system. For facilities with more than one tank system, the containment structure is sized to capture one and one-half (1 1/2) times the cumulative storage capacity of all systems.
- Attachment A - Alternative Methods of Secondary Containment.** Alternative methods for providing secondary containment are proposed. Specifications that show equivalent protection for the Edwards Aquifer are attached. **Discussion provided for piping, hose reels, nozzles, and dispensers.**

3. Inside dimensions and capacity of containment structure(s):

**Table 2 - Secondary Containment**

<i>Length (L) (Ft.)</i>	<i>Width (W) (Ft.)</i>	<i>Height (H) (Ft.)</i>	<i>L x W x H = (Ft3)</i>	<i>Gallons</i>

**Total: \_\_\_\_\_ Gallons**

4.  All piping, hoses, and dispensers will be located inside the containment structure.
- Some of the piping to dispensers or equipment will extend outside the containment structure.
- The piping will be aboveground
- The piping will be underground

5.  The containment area must be constructed of and in a material impervious to the substance(s) being stored. The proposed containment structure will be constructed of the tanks are double-walled poly/steel UL2258 and a concrete pad provides containment for hose reels and nozzles.
6.  **Attachment B - Scaled Drawing(s) of Containment Structure.** A scaled drawing of the containment structure that shows the following is attached:
  - Interior dimensions (length, width, depth and wall and floor thickness).
  - Internal drainage to a point convenient for the collection of any spillage.
  - Tanks clearly labeled.
  - Piping clearly labeled.
  - Dispenser clearly labeled.

## **Site Plan Requirements**

**Items 7 - 18 must be included on the Site Plan.**

7.  The Site Plan must have a minimum scale of 1" = 400'.  
Site Plan Scale: 1" = 200'.
8. 100-year floodplain boundaries:
  - Some part(s) of the project site is located within the 100-year floodplain. The floodplain is shown and labeled.
  - No part of the project site is located within the 100-year floodplain.
  - The 100-year floodplain boundaries are based on the following specific (including date of material) sources(s): FIRM Panel #48091C0445F eff 9/2/2009 and FIRM Panel #48187C0095F eff 11/2/2007.
9.  The layout of the development is shown with existing and finished contours at appropriate, but not greater than ten-foot contour intervals. Show lots, recreation centers, buildings, roads, etc.
  - The layout of the development is shown with existing contours. Finished topographic contours will not differ from the existing topographic configuration and are not shown.
10. All known wells (oil, water, unplugged, capped and/or abandoned, test holes, etc.):
  - There are 1 (#) wells present on the project site and the locations are shown and labeled. (Check all of the following that apply):
    - The wells are not in use and have been properly abandoned.
    - The wells are not in use and will be properly abandoned.
    - The wells are in use and comply with 16 TAC § 76.
  - There are no wells or test holes of any kind known to exist on the project site.
11. Geologic or manmade features which are on the site:

- All sensitive geologic or manmade features identified in the Geologic Assessment are shown and labeled.
  - No sensitive geologic or manmade features were identified in the Geologic Assessment.
  - Attachment C - Exception to the Geologic Assessment.** A request and justification for an exception to a portion of the Geologic Assessment is attached.
12.  The drainage patterns and approximate slopes anticipated after major grading activities.  
**N/A – no grading activities**
13.  Areas of soil disturbance and areas which will not be disturbed. **N/A - none**
14.  Locations of major structural and nonstructural controls. These are the temporary and permanent best management practices. **N/A - none**
15.  Locations where soil stabilization practices are expected to occur. **N/A - none**
16.  Surface waters (including wetlands).  
 N/A
17.  Locations where stormwater discharges to surface water or sensitive features.  
 There will be no discharges to surface water or sensitive features.
18.  Legal boundaries of the site are shown.

### ***Best Management Practices***

19.  Any spills must be directed to a point convenient for collection and recovery. Spills from storage tank facilities must be removed from the controlled drainage area for disposal within 24 hours of the spill.
- In the event of a spill, any spillage will be removed from the containment structure within 24 hours of the spill and disposed of properly.
  - In the event of a spill, any spillage will be drained from the containment structure through a drain and valve within 24 hours of the spill and disposed of properly. The drain and valve system are shown in detail on the scaled drawing.
20.  All stormwater accumulating inside the containment structure will be disposed of through an authorized waste disposal contractor. **N/A**
- Containment area will be covered by a roof.
  - Containment area will not be covered by a roof.
- A description of the alternate method of stormwater disposal is submitted for the executive director's review and approval and is attached.



21.  **Attachment D - Spill and Overfill Control.** A site-specific description of the methods to be used at the facility for spill and overfill control is attached.
22.  **Attachment E - Response Actions to Spills.** A site-specific description of the planned response actions to spills that will take place at the facility is attached.

### ***Administrative Information***

23. A Water Pollution Abatement Plan (WPAP) is required for construction of any associated commercial, industrial or residential project located on the Recharge Zone.
- The WPAP application for this project was approved by letter dated \_\_\_\_\_. A copy of the approval letter is attached at the end of this application.
  - The WPAP application for this project was submitted to the TCEQ on \_\_\_\_\_, but has not been approved.
  - A WPAP application is required for an associated project, but it has not been submitted.
  - There will be no building or structure associated with this project. In the event a building or structure is needed in the future, the required WPAP will be submitted to the TCEQ.
  - The proposed AST is located on the Transition Zone and a WPAP is not required. Information requested in 30 TAC 213.5 subsection (b) (4)(B) and (C) and (5) is provided with this application. (Forms TCEQ-0600 Permanent Stormwater Section and TCEQ-0602 Temporary Stormwater Section or Stormwater Pollution Prevention Plan/SW3P).
24.  This facility is subject to the requirements for the reporting and cleanup of surface spills and overfills pursuant to 30 TAC 334 Subchapter D relating to Release Reporting and Corrective Action.
25.  Submit one (1) original and one (1) copy of the application, plus additional copies as needed for each affected incorporated city, groundwater conservation district, and county in which the project will be located. The TCEQ will distribute the additional copies to these jurisdictions. The copies must be submitted to the appropriate regional office.
26.  Any modification of this AST Facility Plan application will require executive director approval, prior to construction, and may require submission of a revised application, with appropriate fees.

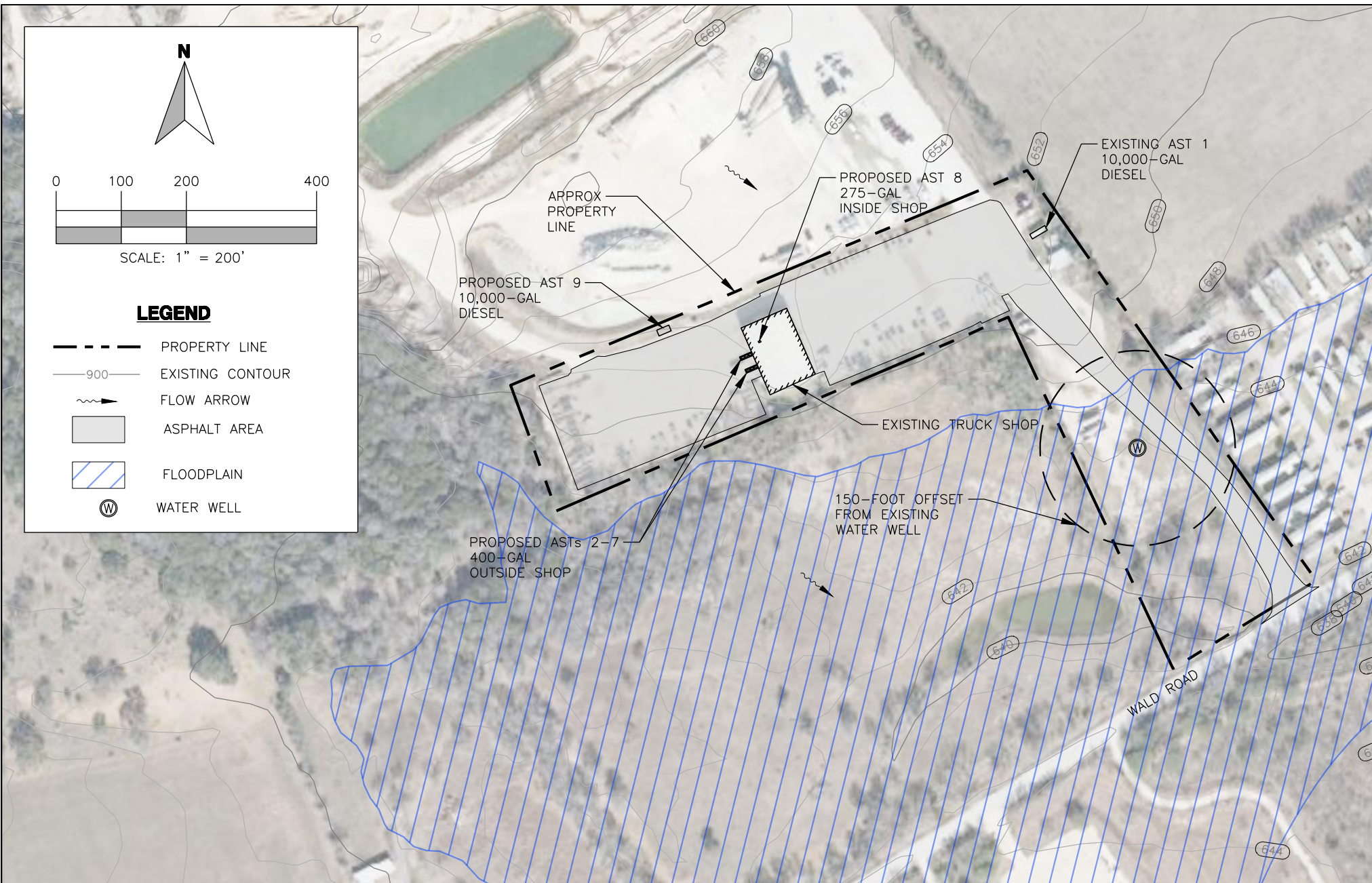

SHEET NO.:  
**1**  
OF 4

IMAGE: BING MAPS	
ISSUE DATE:	02/27/2024
DRAWN BY:	AK
CHECKED BY:	CJF
SCALE:	1" = 200'
JOB NO.:	10101-061

<b>AST SITE PLAN</b>			
BRAUNTEX TRUCK SHOP - 1870 WALD ROAD			
BRAUNTEX MATERIALS, INC.			
NEW BRAUNFELS, COMAL COUNTY, TEXAS			
REV.	DESCRIPTION	BY	DATE

STATE OF TEXAS  
  
 ANDREA KIDD  
 132541  
 PROFESSIONAL ENGINEER

*Andrea Kidd*

**3/4/2024**

**WESTWARD**  
 Environmental. Engineering. Natural Resources.  
 P.O. Box 2205 Boerne, Texas 78006  
 (830) 249-8284 Fax: (830) 249-0221  
 TBPE REG. NO.: F-4524  
 TBPB REG. NO.: 50112

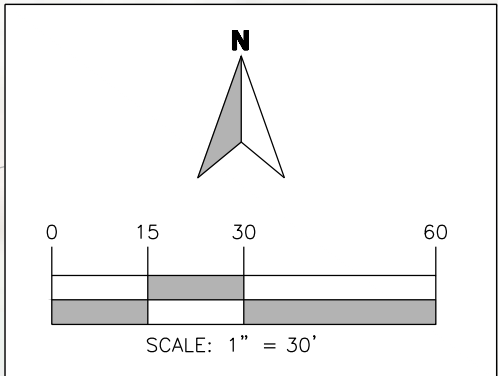

PROPOSED AST 9  
10,000-GAL DOUBLE-WALLED  
DIESEL

PROPOSED ASTs 2-7  
400-GAL DOUBLE-WALLED  
MAINTENANCE OILS

PROPOSED AST 8  
275-GAL DOUBLE-WALLED  
MAINTENANCE OIL  
INSIDE EXISTING SHOP

SHEET NO.:  
**2**  
OF 4

IMAGE: BING MAPS	
ISSUE DATE:	02/27/2024
DRAWN BY:	AK
CHECKED BY:	CJF
SCALE: 1" =	30'
JOB NO.:	10101-061

AST LOCATION - PROPOSED TANKS			
BRAUNTEX TRUCK SHOP - 1870 WALD ROAD			
BRAUNTEX MATERIALS, INC.			
NEW BRAUNFELS, COMAL COUNTY, TEXAS			
REV.	DESCRIPTION	BY	DATE

*Andrea Kidd*  
**3/4/2024**

**WESTWARD**  
Environmental Engineering. Natural Resources.  
P.O. Box 2205 Boerne, Texas 78006  
(830) 249-8284 Fax: (830) 249-0221  
TBPE REG. NO.: F-4524  
TBPG REG. NO.: 50112

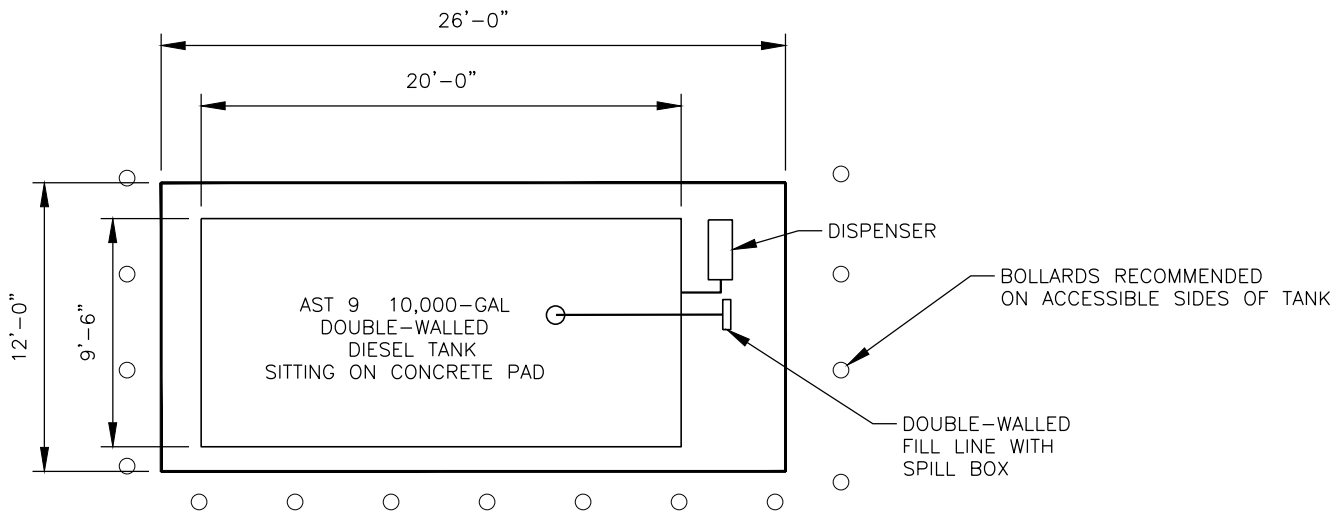

NOTE: SEE ATTACHED MANUFACTURER  
PROVIDED SPECIFICATION SHEETS  
FOR DETAILS ON ASTs 2-9.

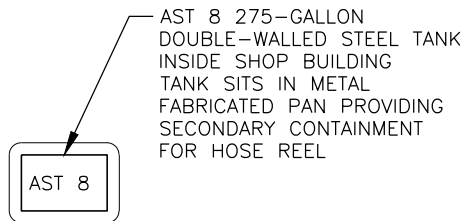

IDENTICAL CONCRETE PADS  
WITH 3-INCH CURB  
PROVIDING SECONDARY  
CONTAINMENT FOR PIPING/HOSES  
WITH BOLLARDS RECOMMENDED

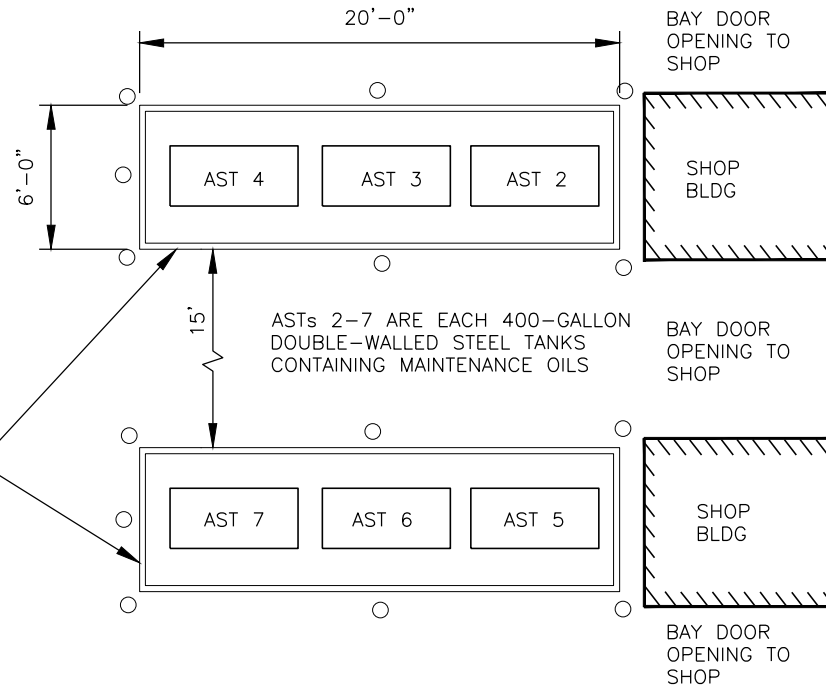

SHEET NO.: <b>3</b> OF 4	IMAGE: N/A	
	ISSUE DATE:	02/29/2024
	DRAWN BY:	AK
	CHECKED BY:	CJF
	SCALE: 1" =	1/8"
	JOB NO.:	10101-061

PROPOSED TANKS			
BRAUNTEX TRUCK SHOP - 1870 WALD ROAD			
BRAUNTEX MATERIALS, INC.			
NEW BRAUNFELS, COMAL COUNTY, TEXAS			
REV.	DESCRIPTION	BY	DATE

STATE OF TEXAS  
ANDREA KIDD  
132541  
LICENSED  
PROFESSIONAL ENGINEER

*Andrea Kidd*  
3/4/2024

**WESTWARD**  
Environmental Engineering. Natural Resources.  
P.O. Box 2205 Boerne, Texas 78006  
(830) 249-8284 Fax: (830) 249-0221  
TBPE REG. NO.: F-4524  
TBPGE REG. NO.: 50112



EDWARDS AQUIFER PROTECTION PROGRAM CONSTRUCTION NOTES – LEGAL DISCLAIMER

THE FOLLOWING/LISTED "CONSTRUCTION NOTES" ARE INTENDED TO BE ADVISORY IN NATURE ONLY AND DO NOT CONSTITUTE AN APPROVAL OR CONDITIONAL APPROVAL BY THE EXECUTIVE DIRECTOR (ED), NOR DO THEY CONSTITUTE A COMPREHENSIVE LISTING OF RULES OR CONDITIONS TO BE FOLLOWED DURING CONSTRUCTION. FURTHER ACTIONS MAY BE REQUIRED TO ACHIEVE COMPLIANCE WITH TCEQ REGULATIONS FOUND IN TITLE 30, TEXAS ADMINISTRATIVE CODE (TAC), CHAPTERS 213 AND 217, AS WELL AS LOCAL ORDINANCES AND REGULATIONS PROVIDING FOR THE PROTECTION OF WATER QUALITY. ADDITIONALLY, NOTHING CONTAINED IN THE FOLLOWING/LISTED "CONSTRUCTION NOTES" RESTRICTS THE POWERS OF THE ED, THE COMMISSION OR ANY OTHER GOVERNMENTAL ENTITY TO PREVENT, CORRECT, OR CURTAIL ACTIVITIES THAT RESULT OR MAY RESULT IN POLLUTION OF THE EDWARDS AQUIFER OR HYDROLOGICALLY CONNECTED SURFACE WATERS. THE HOLDER OF ANY EDWARDS AQUIFER PROTECTION PLAN CONTAINING "CONSTRUCTION NOTES" IS STILL RESPONSIBLE FOR COMPLIANCE WITH TITLE 30, TAC, CHAPTERS 213 OR ANY OTHER APPLICABLE TCEQ REGULATION, AS WELL AS ALL CONDITIONS OF AN EDWARDS AQUIFER PROTECTION PLAN THROUGH ALL PHASES OF PLAN IMPLEMENTATION. FAILURE TO COMPLY WITH ANY CONDITION OF THE ED'S APPROVAL, WHETHER OR NOT IN CONTRADICTION OF ANY "CONSTRUCTION NOTES," IS A VIOLATION OF TCEQ REGULATIONS AND ANY VIOLATION IS SUBJECT TO ADMINISTRATIVE RULES, ORDERS, AND PENALTIES AS PROVIDED UNDER TITLE 30, TAC § 213.10 (RELATING TO ENFORCEMENT). SUCH VIOLATIONS MAY ALSO BE SUBJECT TO CIVIL PENALTIES AND INJUNCTION. THE FOLLOWING/LISTED "CONSTRUCTION NOTES" IN NO WAY REPRESENT AN APPROVED EXCEPTION BY THE ED TO ANY PART OF TITLE 30 TAC, CHAPTERS 213 AND 217, OR ANY OTHER TCEQ APPLICABLE REGULATION

- A WRITTEN NOTICE OF CONSTRUCTION MUST BE SUBMITTED TO THE TCEQ REGIONAL OFFICE AT LEAST 48 HOURS PRIOR TO THE START OF ANY GROUND DISTURBANCE OR CONSTRUCTION ACTIVITIES. THIS NOTICE MUST INCLUDE:
  - THE NAME OF THE APPROVED PROJECT;
  - THE ACTIVITY START DATE; AND
  - THE CONTACT INFORMATION OF THE PRIME CONTRACTOR.
- ALL CONTRACTORS CONDUCTING REGULATED ACTIVITIES ASSOCIATED WITH THIS PROJECT SHOULD BE PROVIDED WITH COMPLETE COPIES OF THE APPROVED AST PLAN AND THE TCEQ LETTER INDICATING THE SPECIFIC CONDITIONS OF ITS APPROVAL. DURING THE COURSE OF THESE REGULATED ACTIVITIES, THE CONTRACTOR(S) SHOULD KEEP COPIES OF THE APPROVED PLAN AND APPROVAL LETTER ON-SITE.
- NO HAZARDOUS SUBSTANCE STORAGE TANK SHALL BE INSTALLED WITHIN 150 FEET OF A WATER SUPPLY SOURCE, DISTRIBUTION SYSTEM, WELL, OR SENSITIVE FEATURE.
- PRIOR TO BEGINNING ANY CONSTRUCTION ACTIVITY, ALL TEMPORARY EROSION AND SEDIMENTATION (E&S) CONTROL MEASURES MUST BE PROPERLY INSTALLED AND MAINTAINED IN ACCORDANCE WITH THE MANUFACTURERS SPECIFICATIONS. IF INSPECTIONS INDICATE A CONTROL HAS BEEN USED INAPPROPRIATELY, OR INCORRECTLY, THE APPLICANT MUST REPLACE OR MODIFY THE CONTROL FOR SITE SITUATIONS. THESE CONTROLS MUST REMAIN IN PLACE UNTIL THE DISTURBED AREAS HAVE BEEN PERMANENTLY STABILIZED.
- ANY SEDIMENT THAT ESCAPES THE CONSTRUCTION SITE MUST BE COLLECTED AND PROPERLY DISPOSED OF BEFORE THE NEXT RAIN EVENT TO ENSURE IT IS NOT WASHED INTO SURFACE STREAMS, SENSITIVE FEATURES, ETC.
- SEDIMENT MUST BE REMOVED FROM THE SEDIMENT TRAPS OR SEDIMENTATION BASINS WHEN IT OCCUPIES 50% OF THE BASIN'S DESIGN CAPACITY.
- LITTER, CONSTRUCTION DEBRIS, AND CONSTRUCTION CHEMICALS EXPOSED TO STORMWATER SHALL BE PREVENTED FROM BEING DISCHARGED OFFSITE.
- ALL EXCAVATED MATERIAL THAT WILL BE STORED ON-SITE MUST HAVE PROPER E&S CONTROLS.
- IF PORTIONS OF THE SITE WILL HAVE A CEASE IN CONSTRUCTION ACTIVITY LASTING LONGER THAN 14 DAYS, SOIL STABILIZATION IN THOSE AREAS SHALL BE INITIATED AS SOON AS POSSIBLE PRIOR TO THE 14TH DAY OF INACTIVITY. IF ACTIVITY WILL RESUME PRIOR TO THE 21ST DAY, STABILIZATION MEASURES ARE NOT REQUIRED. IF DROUGHT CONDITIONS OR INCLEMENT WEATHER PREVENT ACTION BY THE 14TH DAY, STABILIZATION MEASURES SHALL BE INITIATED AS SOON AS POSSIBLE.
- THE FOLLOWING RECORDS SHOULD BE MAINTAINED AND MADE AVAILABLE TO THE TCEQ UPON REQUEST:
  - THE DATES WHEN MAJOR GRADING ACTIVITIES OCCUR;
  - THE DATES WHEN CONSTRUCTION ACTIVITIES TEMPORARILY OR PERMANENTLY CEASE ON A PORTION OF THE SITE; AND
  - THE DATES WHEN STABILIZATION MEASURES ARE INITIATED.
- THE HOLDER OF ANY APPROVED AST PLAN MUST NOTIFY THE APPROPRIATE REGIONAL OFFICE IN WRITING AND OBTAIN APPROVAL FROM THE EXECUTIVE DIRECTOR PRIOR TO INITIATING ANY OF THE FOLLOWING:
  - ANY PHYSICAL OR OPERATIONAL MODIFICATION OF ANY BEST MANAGEMENT PRACTICES (BMPS) OR STRUCTURE(S), INCLUDING BUT NOT LIMITED TO TEMPORARY OR PERMANENT PONDS, DAMS, BERMS, SILT FENCES, AND DIVERSIONARY STRUCTURES;
  - ANY CHANGE IN THE NATURE OR CHARACTER OF THE REGULATED ACTIVITY FROM THAT WHICH WAS ORIGINALLY APPROVED;
  - ANY CHANGE THAT WOULD SIGNIFICANTLY IMPACT THE ABILITY TO PREVENT POLLUTION OF THE EDWARDS AQUIFER; OR
  - ANY DEVELOPMENT OF LAND PREVIOUSLY IDENTIFIED AS UNDEVELOPED IN THE APPROVED CONTRIBUTING ZONE PLAN.

AUSTIN REGIONAL OFFICE  
12100 PARK 35 CIRCLE, BUILDING A  
AUSTIN, TEXAS 78753-1808  
PHONE (512) 339-2929  
FAX (512) 339-3795

SAN ANTONIO REGIONAL OFFICE  
14250 JUDSON ROAD  
SAN ANTONIO, TEXAS 78233-4480  
PHONE (210) 490-3096  
FAX (210) 545-4329

THESE GENERAL CONSTRUCTION NOTES MUST BE INCLUDED ON THE CONSTRUCTION PLANS PROVIDED TO THE CONTRACTOR AND ALL SUBCONTRACTORS.

GENERAL NOTES

- THE CONTRACTOR SHALL BE RESPONSIBLE AT ALL TIMES THROUGHOUT THE DURATION OF CONSTRUCTION FOR THE PROTECTION OF EXISTING AND NEWLY INSTALLED FACILITIES FROM DAMAGE OR DISRUPTION OF SERVICE. THE CONTRACTOR SHALL BE RESPONSIBLE FOR TAKING SUCH MEASURES AS NECESSARY TO PROTECT THE HEALTH, SAFETY, AND WELFARE OF THOSE PERSONS HAVING ACCESS TO THE WORK SITE.
- FACILITIES PROPOSED HEREIN SHALL BE CONSTRUCTED IN ACCORDANCE WITH THE APPROVED PLANS. DEVIATIONS FROM THE APPROVED PLANS MUST BE APPROVED IN ADVANCE BY THE ENGINEER OF RECORD.
- UPON COMPLETION OF CONSTRUCTION AND PRIOR TO FINAL ACCEPTANCE OF THE WORK, A FINAL INSPECTION SHALL VERIFY PROPER ADHERENCE TO ALL FACETS OF THE PLANS AND SPECIFICATIONS.
- AS-BUILT DRAWINGS SHALL BE PREPARED BY A REGISTERED LAND SURVEYOR, REGISTERED IN THE STATE OF TEXAS, AND SUBMITTED BY THE CONTRACTOR TO THE ENGINEER OF RECORD. CONTRACTOR TO PROVIDE RECORD INFORMATION WHICH LOCATES ALL UNDERGROUND UTILITIES, SITE GRADING AND CLEARANCE TO WATER MAIN FROM OTHER UTILITIES HORIZONTAL AND VERTICAL.
- CONTRACTOR SHALL NOTIFY TEXAS811 ONE CALL SYSTEM (1-800-344-8377) 48 HOURS IN ADVANCE OF CONSTRUCTION.
- ALL VEGETATION, DEBRIS, CONCRETE OR OTHER UNSUITABLE MATERIAL SHALL BE LEGALLY DISPOSED OF OFF-SITE IN AN APPROPRIATE AREA AT THE CONTRACTORS EXPENSE.
- CONTRACTOR SHALL UTILIZE CONSTRUCTION METHODS AND DEVICES, SUCH AS TURBIDITY SCREENS, CURTAINS AND FLOATING SILT BARRIERS WHERE NECESSARY IN ORDER TO COMPLY WITH ALL STATE AND LOCAL WATER QUALITY STANDARDS.
- ALL CONSTRUCTION SHALL BE DONE IN A SAFE MANNER, SPECIFICALLY, THE RULES AND REGULATIONS OF THE OCCUPATIONAL SAFETY AND HEALTH ADMINISTRATION AND THE MANUAL OF UNIFORM TRAFFIC CONTROL DEVICES SHALL BE STRICTLY OBSERVED.
- MINIMUM COVER SHALL BE 3.0 FEET FOR ALL PIPES. (TYPICAL) UNLESS OTHERWISE NOTED ON DRAWINGS.
- ALL OPEN TRENCHES AND HOLES ADJACENT TO ROADWAY OR WALKWAYS SHALL BE PROPERLY MARKED AND BARRICADED TO ASSURE THE SAFETY OF BOTH VEHICULAR AND PEDESTRIAN TRAFFIC.
- CONTRACTOR SHALL MONITOR AND PROHIBIT THE DEFACING OF FRESHLY PLACED CONCRETE SURFACES. ANY CONCRETE SURFACES DEFACED SHALL BE REPLACED AT NO ADDITIONAL COST TO THE OWNER.
- CLEARING AND GRUBBING SHALL INCLUDE REMOVAL OF ALL VEGETATION AS REQUIRED TO CONSTRUCT THE REQUIRED IMPROVEMENTS.
- PROJECT SITE SAFETY:
  - THE ENGINEER/OWNER OR THEIR EMPLOYEES HAVE NO AUTHORITY TO EXERCISE ANY CONTROL OVER THE CONTRACTOR, ANY SUB-CONTRACTOR OR OTHER ENTITY OR THEIR EMPLOYEES IN CONNECTION WITH THEIR WORK OR ANY JOBSITE HEALTH OR SAFETY PRECAUTIONS.
  - THE CONTRACTOR IS SOLELY RESPONSIBLE FOR JOBSITE SAFETY, AND WARRANTS THAT THIS INTENT IS MADE EVIDENT BY THE AGREEMENT BETWEEN OWNER AND CONTRACTOR.
  - ALL EXISTING OVERHEAD AND UNDERGROUND UTILITIES SHOWN ON THESE DRAWINGS OR ENCOUNTERED THROUGH THE PROGRESSION OF WORK AT THIS PROJECT SITE ARE ASSUMED TO BE LIVE, CONTRACTOR SHALL BE RESPONSIBLE FOR ALL SAFETY PRECAUTIONS WHEN WORKING AROUND EXISTING OVERHEAD OR UNDERGROUND UTILITIES.
- ALL CONCRETE SHALL DEVELOP A MINIMUM OF 4000 p.s.i. COMPRESSIVE STRENGTH AT 28 DAYS, UNLESS OTHERWISE STATED.
- THE SEQUENCE OF CONSTRUCTION SHALL BE SUCH THAT ALL UNDERGROUND INSTALLATION OF ANY KIND THAT WILL COME UNDER THE PAVEMENT OR WITHIN 10 FEET OF ITS EDGES SHALL BE INSTALLED PRIOR TO THE CONSTRUCTION OF THE BASE.
- TRENCHES SHALL BE DRY WHEN PIPES ARE INSTALLED. PIPES PLACED BELOW THE WATER TABLE SHALL BE BEDDED ON PEA GRAVEL AND WELL POINT SYSTEMS SHALL BE USED. ALL DEWATERING PERMITS ARE THE RESPONSIBILITY OF THE CONTRACTOR.
- SIX (6) COPIES OF ALL SHOP DRAWINGS SHALL BE SUBMITTED FOR APPROVAL PRIOR TO CONSTRUCTION. ALL REQUESTS FOR MATERIAL SUBSTITUTIONS MUST BE APPROVED PRIOR TO DELIVERY TO THE SITE. SHOP DRAWINGS SHALL BE SUBMITTED FOR ALL MANUFACTURED ITEMS.
- ALL ROOTS IN THE PAVED AREA MUST BE REMOVED ONE FOOT BELOW THE BOTTOM OF SUB GRADE.
- ALL CONSTRUCTION SHALL BE IN ACCORDANCE WITH THE STDS OF TCEQ
- CONTRACTOR SHALL PERFORM ALL WORK NECESSARY TO LOCATE, EXCAVATE AND PREPARE FOR CONNECTIONS TO THE EXISTING SYSTEMS AS SHOWN ON THE DRAWINGS.
- IF SOD IS USED ONSITE, IT SHALL BE PLACED 2" BELOW THE EDGES OF PAVEMENT TO ALLOW WATER TO DRAIN.
- CONTOURS SHOWN ARE PRE DEVELOPMENT CONTOURS
- COMPACTION NOTES:
  - FOR FILL AREAS WHERE WATER WILL BE IMPOUNDED:
  - 23.1. PLACE FILL IN LIFTS NO MORE THAN 12" DEEP AT NEAR OPT. MOISTURE CONTENT.
  - 23.2. COMPACT TO AT LEAST 95% RC (ASTM D698)
  - 23.3. COMPACT TO SLOPE OF FACE
    - FOR ON GRADE BERMS AND OTHER MISC. FILL
  - 23.4. PLACE CLEAN FILL IN 12" LIFTS
  - 23.5. COMPACT WITH ON-SITE HEAVY EQUIPMENT
- ALL CONCRETE SURFACES TO BE BROOM FINISH UNO
- DRAINAGE STRUCTURES TO MEET MIN. TxDOT SPECIFICATIONS FOR CONSTRUCTION AND PLACEMENT OF TYPE 3 DROP INLET
- CONTRACTOR SHALL VERIFY ALL EXISTING CONDITIONS AND GRADING PRIOR TO CONSTRUCTION. ENGINEER OF RECORD SHALL BE NOTIFIED OF ANY DISCREPANCIES PRIOR TO CONSTRUCTION.
- ALL RIP RAP SHALL BE COURSE GRADED ROCK AND SHALL BE SIZED IN ACCORDANCE WITH THE FOLLOWING TABLE

SLOPE	RIP RAP SIZE
0.5%-1%	4" ROCK
1.1% TO 2%	6" ROCK
2.1% TO 4%	8" ROCK
4.1% TO 5%	8"-12" ROCK

- MIN THICKNESS OF RIPRAP TO BE 1.5 TIMES THE STONE DIAMETER UNO
- GEOTEXTILE FABRIC (FILTER FABRIC) SHALL BE A MON-WOVEN POLYPROPALENE FABRIC DESIGNED SPECIFICALLY FOR USE AS A SOIL FILTRATION MEDIA w/ APPROX. WEIGHT 6 OZ/YD<sup>2</sup>, A MULLEN BURST RATting OF 140 PSI, AND AN EQUIVALENT OPENING SIZE (ESO) GREATER THAN #50 SIEVE. TENCATE MIRIFI N-SERIES OF APPROVED EQUAL.
- BASIN LINERS OVER THE RECHARGE ZONE SHALL COMPLY w/ RG-348 FOR COMPACTED CLAY LINERS.
- ALL DISTURBED AREAS TO BE SEEDED AND MULCHED FOR SLOPE STABILIZATION. SEED TO BE BERMUDA GRASS OR APPROVED ALTERNATES.
- ALL CONCRETE SLABS TO HAVE #5 BARS EACH WAY AT 12" c/c IN CENTER OF SLAB UNO.

BMP CONSTRUCTION NOTES

- COMPACTED EARTHEN BERM
  - INSTALLATION: COMPRISED OF SOIL AND OVERBURDEN MATTER EITHER GENERATED ONSITE OR DELIVERED FROM OFFSITE. COMPACT WITH HEAVY EQUIPMENT IN 12" (MAX) LIFTS.

MAINTENANCE (TEMPORARY):  
INSPECT BERMS ONCE A MONTH UNTIL SUFFICIENTLY VEGETATED. REPLACE AS NECESSARY.

- ROCK BERM
  - SHOULD BE SECURED WITH A WOVEN WIRE SHEATHING, MAX. OPENING 1" AND MIN. WIRE DIA. 20 GAUGE GALVANIZED. SECURE WITH SHOAT RINGS.

INSTALLATION:  
AGGREGATE USED SHOULD BE COMPRISED OF OPEN GRADED 3-5" DIAMETER ROCK. BERM SHOULD BE PLACED PERPENDICULAR TO FLOW LINE. SIDE SLOPE MUST BE 2:1 OR FLATTER. WIRE SHEATHING MUST BE SECURED WITH TIE WIRE SO THEY OVERLAP AT LEAST 2". BERM SHOULD BE BURIED IN A TRENCH APPROX. 4" DEEP.

MAINTENANCE (TEMPORARY):  
INSPECT BERMS ONCE A WEEK. REMOVE SEDIMENT AND OTHER DEBRIS WHEN BUILDUP REACHES 6". REPLACE WHEN ROCK BECOMES CLOGGED WITH SEDIMENT.

ALTERNATE #1 & #2 ROCK BERMS (WEI)

INSTALLATION:  
AGGREGATE USED SHOULD BE COMPRISED OF OPEN GRADED 3-5" DIAMETER ROCK. BERM SHOULD BE PLACED PERPENDICULAR TO FLOW LINE.

MAINTENANCE (TEMPORARY):  
INSPECT BERMS ONCE A WEEK. REMOVE SEDIMENT AND OTHER DEBRIS WHEN BUILDUP REACHES 6". REPLACE WHEN ROCK BECOMES CLOGGED WITH SEDIMENT.

- SILT FENCE W/ TRENCHED TOE

INSTALLATION:  
3.1 STEEL POSTS SHOULD BE INSTALLED ON A SLIGHT ANGLE TOWARD THE ANTICIPATED RUNOFF SOURCE. POSTS MUST BE EMBEDDED A MIN. OF 1' DEEP AND SPACED NOT MORE THAN 8' ON CENTER, WHERE WATER CONCENTRATES, THE MAX. SPACING SHOULD BE 6'.

3.2 LAY OUT FENCING DOWN SLOPE OF DISTURBED AREA, FOLLOWING THE CONTOUR AS CLOSELY AS POSSIBLE.

3.3 THE TOE OF THE SILT FENCE SHOULD BE TRENCHED IN WITH A SPADE OR MECHANICAL TRENCHER, SO THAT THE DOWN-SLOPE FACE OF THE TRENCH IS FLAT AND PERPENDICULAR TO THE LINE OF FLOW. WHERE FENCE CANNOT BE TRENCHED IN (E.G. PAVEMENT OR ROCK OUTCROP), WEIGHT FABRIC FLAP WITH 3 IN. OF PEA GRAVEL ON UPHILL SIDE TO PREVENT FLOW FROM SEEPING UNDER FENCE.

3.4 THE TRENCH MUST BE A MIN. OF 6 IN. DEEP AND 6 IN. WIDE TO ALLOW FOR THE SILT FENCE FABRIC TO BE LAID IN THE GROUND AND BACKFILLED WITH COMPACTED MATERIAL.

3.5 SILT FENCE SHOULD BE SECURELY FASTENED TO EACH STEEL SUPPORT POST OR TO WOVEN WIRE, WHICH IS IN TURN ATTACHED TO THE STEEL FENCE POST. THERE SHOULD BE A 3-FOOT OVERLAP, SECURELY FASTENED WHERE ENDS OF FABRIC MEET.

3.6 INSPECT SILT FENCES ONCE A WEEK. REMOVE SEDIMENT AND OTHER DEBRIS WHEN BUILDUP REACHES 6". REPLACE SILT FENCES WHEN TORN OR OTHERWISE UNABLE TO FILTER SEDIMENT.

- STABILIZED CONSTRUCTION ENTRANCE INSTALLATION:

4.1 AVOID CURVES ON PUBLIC ROADS AND STEEP SLOPES. REMOVE VEGETATION AND OTHER OBJECTIONABLE MATERIAL FROM THE FOUNDATION AREA. GRADE CROWN FOUNDATION FOR POSITIVE DRAINAGE.

4.2 THE MINIMUM WIDTH OF THE ENTRANCE/EXIT SHOULD BE 12' OR THE FULL WIDTH OF EXIT ROADWAY, WHICHEVER IS GREATER.

4.3 THE CONSTRUCTION ENTRANCE SHOULD BE 50' LONG.

4.4 IF THE SLOPE TOWARD THE ROAD EXCEEDS 2%, CONSTRUCT A RIDGE, 6-8" HIGHT WITH 3:1 (H:V) SIDE SLOPES, ACROSS THE FOUNDATION APPROXIMATELY 15 FEET FROM THE ENTRANCE TO DIVERT RUNOFF AWAY FROM THE PUBLIC ROAD.

4.5 PLACE GEOTEXTILE FABRIC AND GRADE FOUNDATION TO IMPROVE STABILITY, ESPECIALLY WHERE WET CONDITIONS ARE ANTICIPATED.

4.6 PLACE STONE TO DIMENSION AND GRADE SHOWN ON PLANS. LEAVE SURFACE SMOOTH AND SLOPE FOR DRAINAGE.

4.7 INSTALL A PIPE UNDER PAD AS NEEDED TO MAINTAIN PROPER PUBLIC ROAD DRAINAGE.

MAINTENANCE: INSPECT WEEKLY. REPLACE STONE AS NECESSARY TO PREVENT TRACKING OFF-SITE.

GEOTEXTILE FABRIC PROPERTIES:

- o MIN. 6 OZ/SQ. YD.; 140 LB/SQ. IN MULLEN BURST;
- o EQUIVALENT OPENING SIZE MIN. 50 SIEVE.
- o GRADE SLOPE TO DRAIN.
- o ADD ADDITIONAL STONE AS REQUIRED.
- o STABILIZED CONSTRUCTION EXIT SHOULD EXTEND FULL WIDTH OF ROAD.

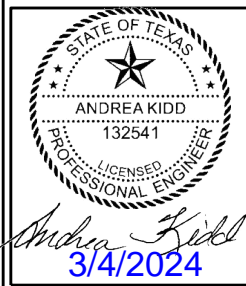

CONSTRUCTION NOTES	
AST PLAN - BRAUNTEX TRUCK SHOP	DATE
BRAUNTEX MATERIALS, INC.	BY
NEW BRAUNFELS, COMAL COUNTY, TEXAS	DATE
DESCRIPTION	BY
REV.	DATE

IMAGE:	N/A
ISSUE DATE:	02/22/2024
DRAWN BY:	AK
CHECKED BY:	CJF
SCALE:	1" = NTS
JOB NO.:	10101-061

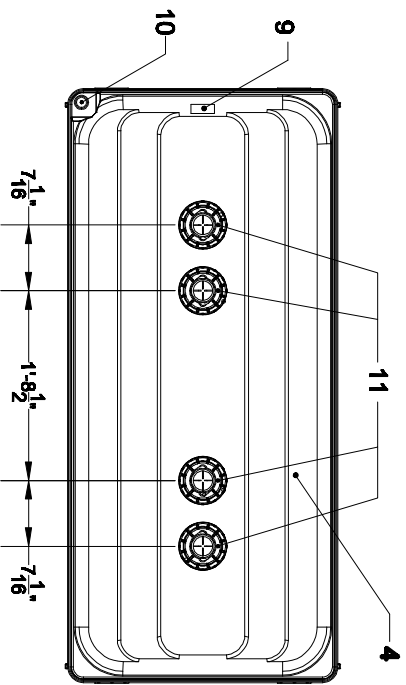
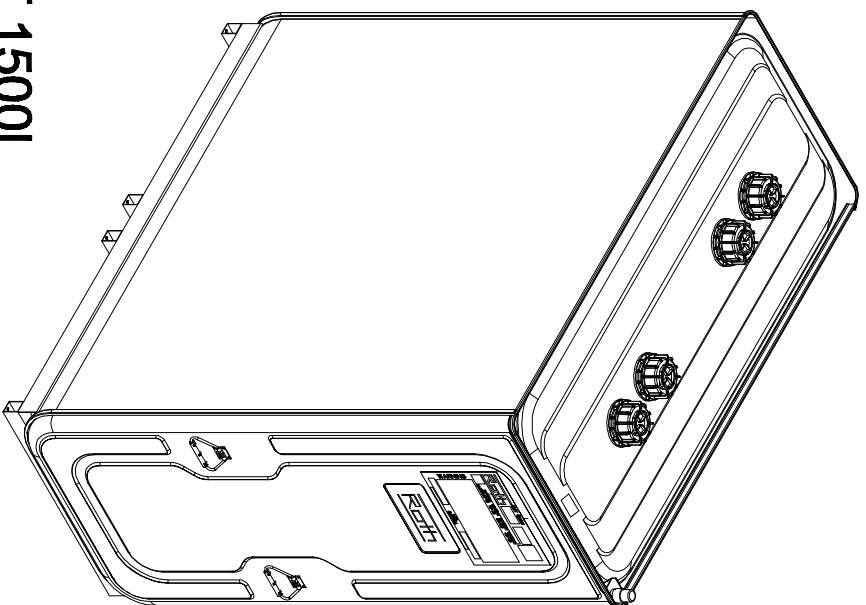
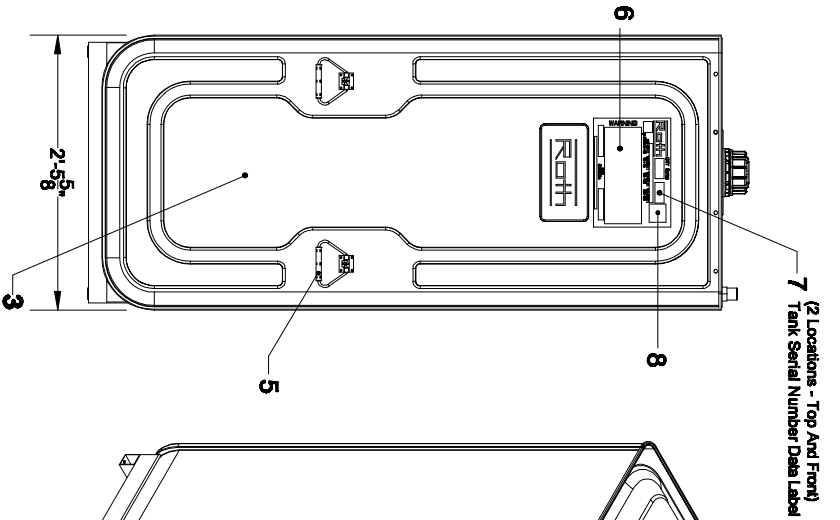
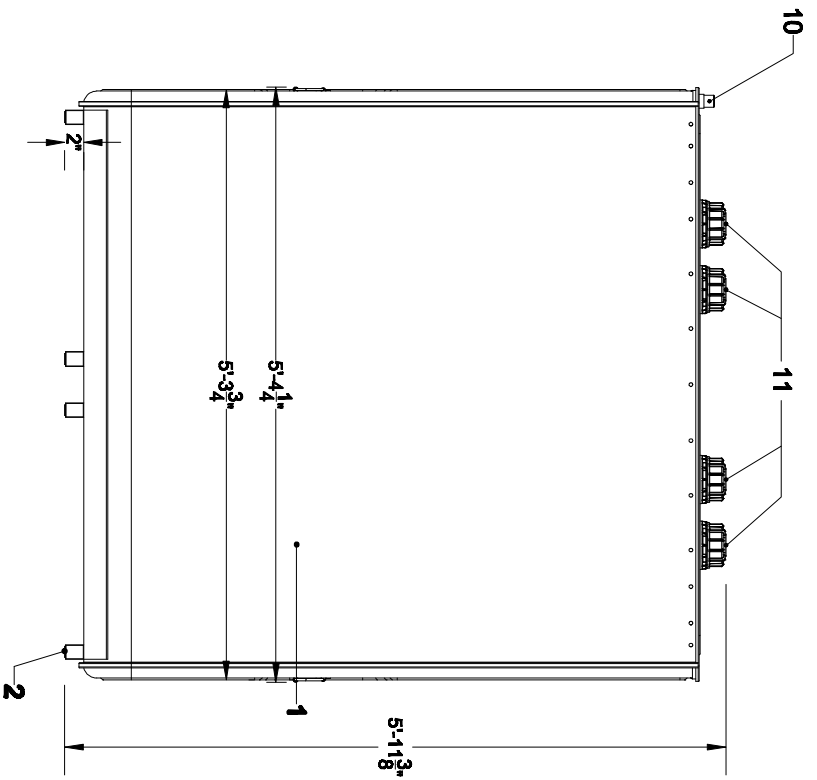

## Roth Industries DWT 1500L

### Legend

- |   |                    |
|---|--------------------|
| 1. Tank Side  | 6. Warning Label   |
| 2. Tank Base  | 7. Serial Number   |
| 3. Tank End   | 8. UL Number       |
| 4. Tank Top   | 9. Serial Number   |
| 5. Handle   | 10. Leak Indicator |
| 11. Connections Molded Into Inner Tank - Proprietary Piping Accessories Used For Either 2" NPT Black Iron Pipe or 3/8" & 1/2" Copper Tubing |                    |

### Specifications

- Height - 72"  
 Width - 30"  
 Length - 64"  
 Weight - 333 Lb.  
 Capacity - 400 Gal.  
 Outer Tank Capacity - 110% of Inner Tank  
 Outer Tank - 19 GA. Galvanized Steel  
 Inner Tank - 3/16" Thick High Density Polyethylene

## ASTs 2-7

Specifications: Roth DWT EcoPLUS3 400 Gal

400 Gallon UL SU 2258 double wall vertical tank to be installed singly or in batteries to store fuel oil, lubricating oils and automotive fluids per NFPA 30, 30A and 31.

Agency Certification- Product to be tested, listed and labeled per- Underwriters Laboratories SU 2258 for oil burner fuels and other combustible liquids.

Construction- Inner tank-blow molded high molecular weight-high density polyethylene 0.25" wall thickness. Outer tank- roll formed 19 ga. galvanized steel. Secondary containment capacity-110% of primary volume

Leak Detection- Tank to be furnished with leak detection device to indicate primary tank leakage.

Connections- to include four (4) top mounted 2in metallic FPT fittings

Tie-down and Support- Tank to be furnished with a tie down kit consisting of stainless steel stays, galvanized steel turnbuckles and hardware. Tank to be furnished with a Tank Base fabricated from galvanized steel tubing.

Testing- primary and secondary tanks to be pressure tested in the factory prior to assembly to ensure liquid tightness.

Dimensions- Length-63.70"      Width-29.65"      Height-66.92" (HOA-71.66")

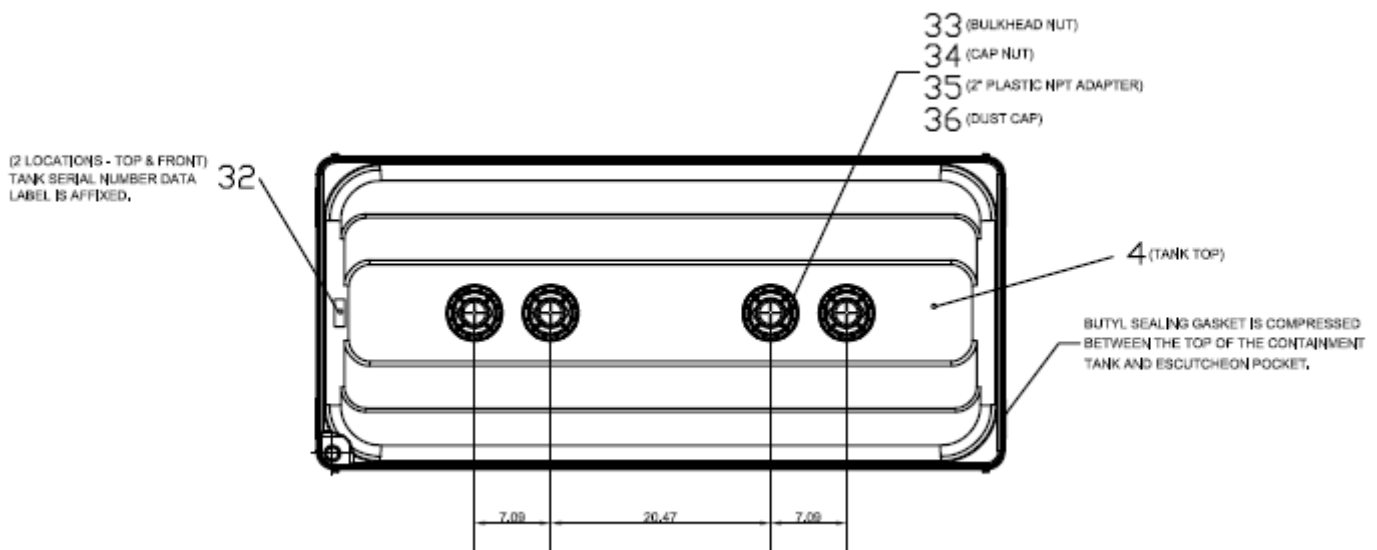

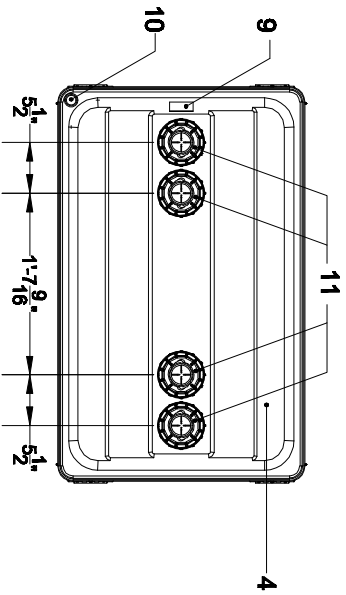
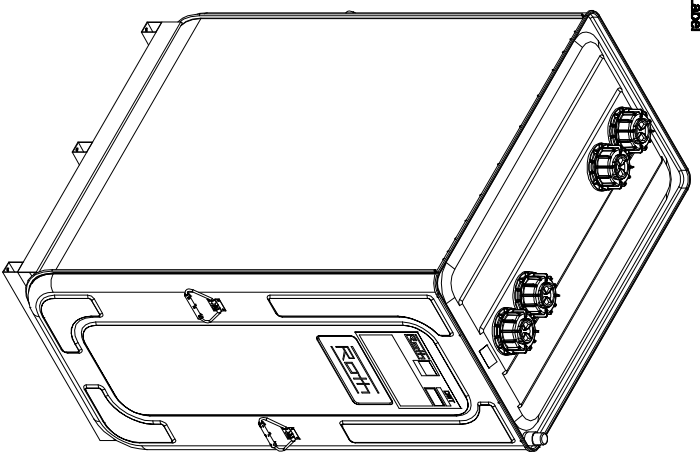
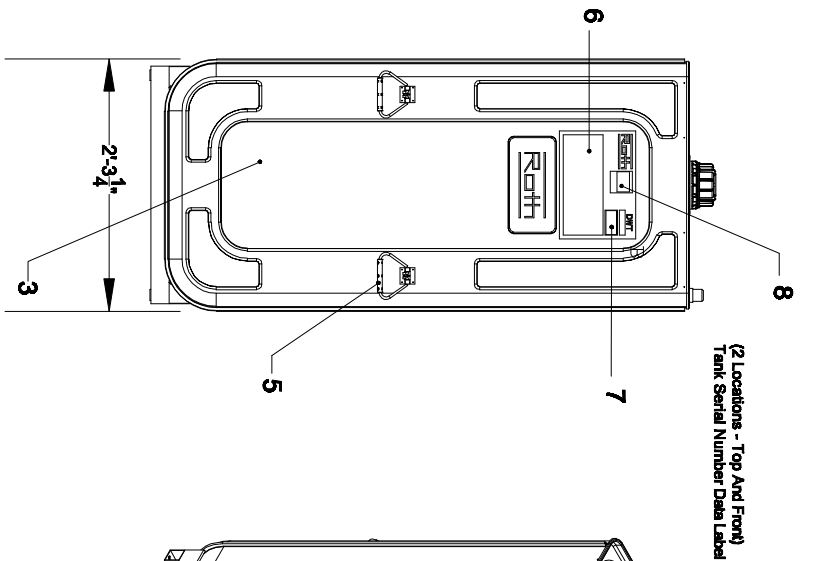
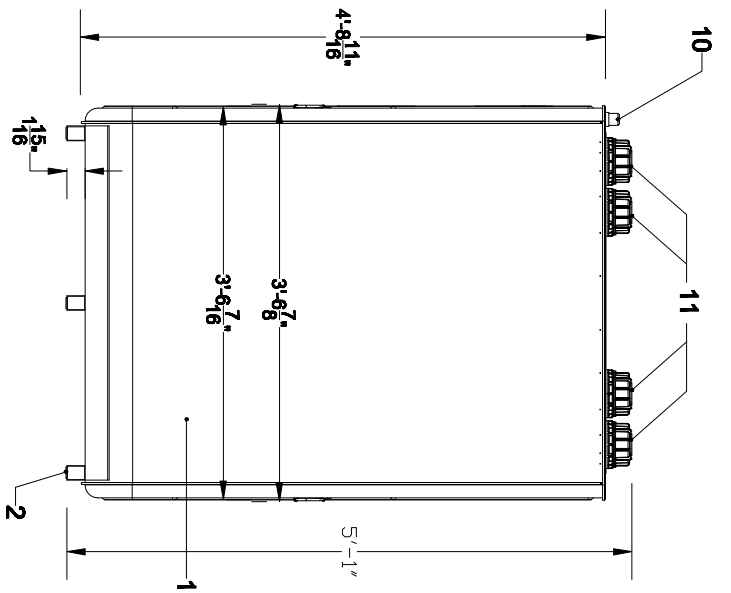

# Roth Industries DWT 1000L

## Legend

- |   |                    |
|---|--------------------|
| 1. Tank Side  | 6. Warning Label   |
| 2. Tank Base  | 7. Serial Number   |
| 3. Tank End   | 8. UL Number       |
| 4. Tank Top   | 9. Serial Number   |
| 5. Handle   | 10. Leak Indicator |
| 11. Connections Molded Into Inner Tank - Proprietary Piping Accessories For Either 2" NPT Black Iron Pipe or 3/8" & 1/2" Copper Tubing Used |                    |

## Specifications

- |  |
|--|
| Height - 61"                                       |
| Width - 28"  |
| Length - 43"                                       |
| Weight - 167 Lb.                                   |
| Capacity - 275 Gal.                                |
| Outer Tank Capacity - 110% of Inner Tank           |
| Outer Tank - 19 GA. Galvanized Steel               |
| Inner Tank - 3/16" Thick High Density Polyethylene |



## AST 8

Specifications: Roth DWT EcoPLUS3 275 Gal

275 Gallon UL SU 2258 double wall vertical tank to be installed singly or in batteries to store fuel oil, lubricating oils and automotive fluids per NFPA 30, 30A and 31.

Agency Certification- Product to be tested, listed and labeled per- Underwriters Laboratories SU 2258 for oil burner fuels and other combustible liquids.

Construction- Inner tank-blow molded high molecular weight-high density polyethylene 0.25" wall thickness. Outer tank- roll formed 19 ga. galvanized steel. Secondary containment capacity-110% of primary volume

Leak Detection- Tank to be furnished with leak detection device to indicate primary tank leakage.

Connections- to include four (4) top mounted 2in metallic FPT fittings

Tie-down and Support- Tank to be furnished with a tie down kit consisting of stainless steel stays, galvanized steel turnbuckles and hardware. Tank to be furnished with a Tank Base fabricated from galvanized steel tubing.

Testing- primary and secondary tanks to be pressure tested in the factory prior to assembly to ensure liquid tightness.

Dimensions- Length-43.13"      Width-27.33"      Height-56.79" (HOA-61.00")

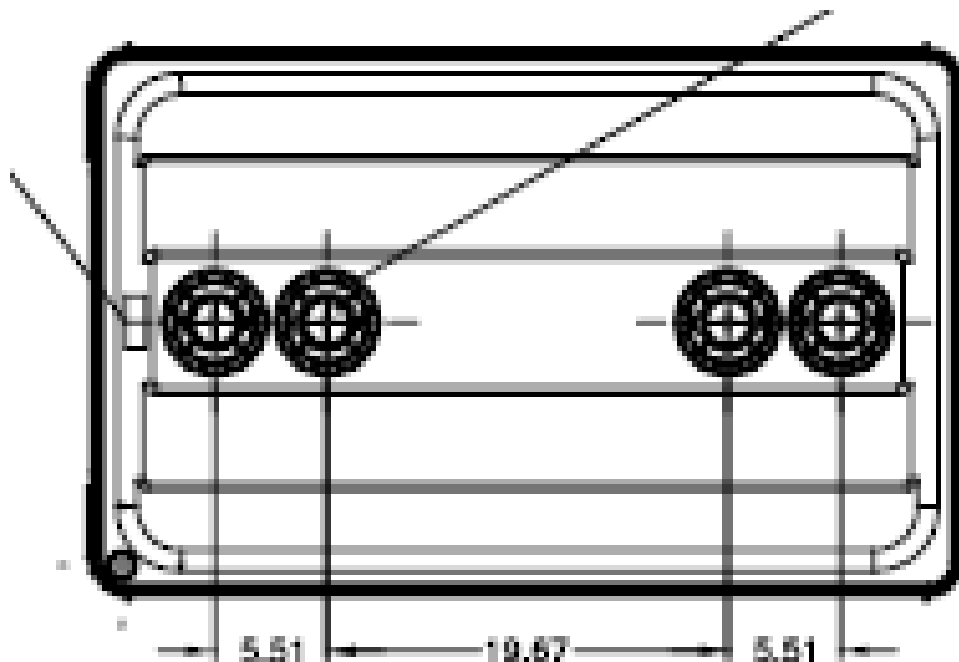

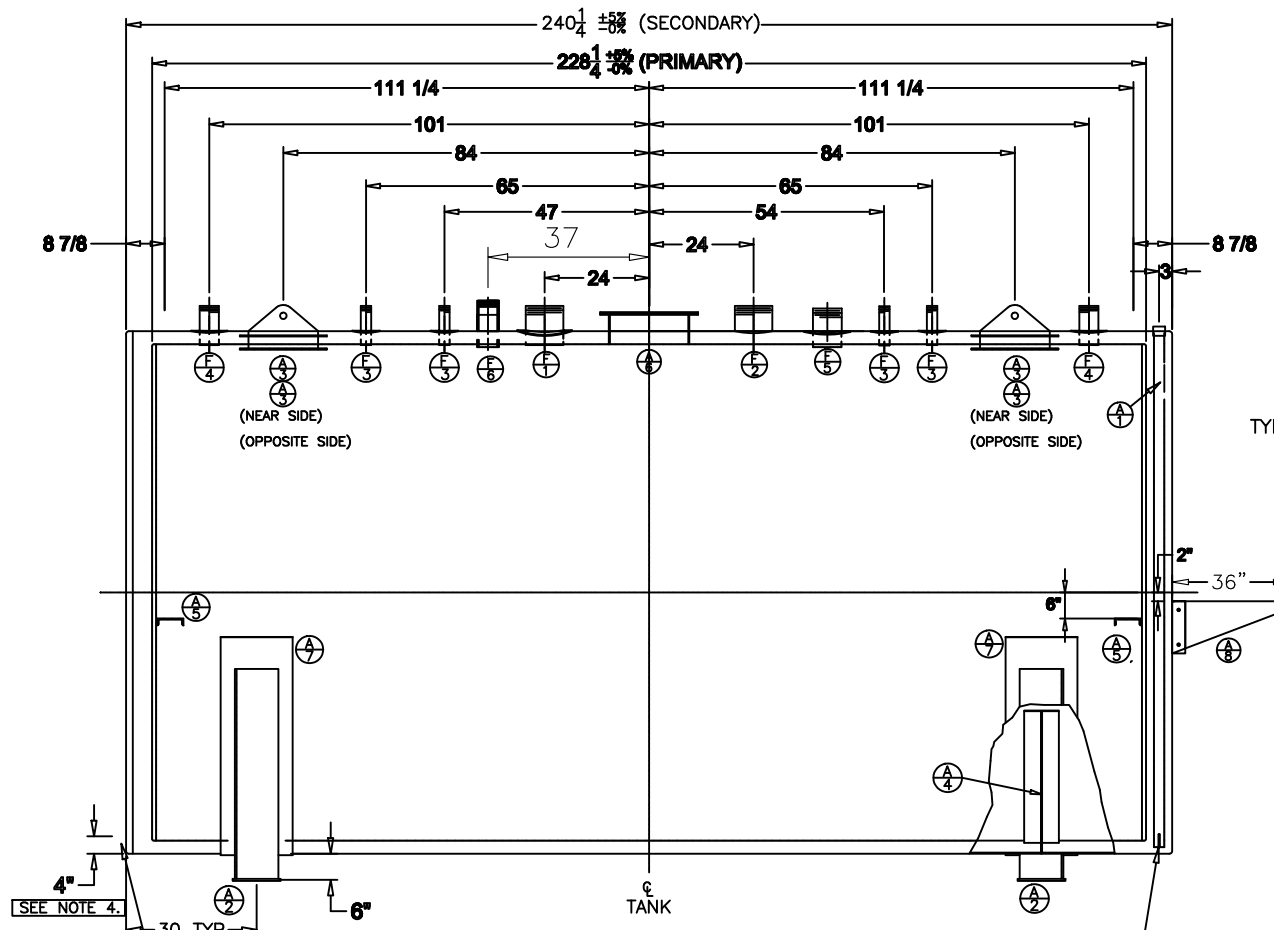

SIDE ELEVATION

AFTER CUTTING SLOTS, DUCT TAPE HOLE SO THAT PERLITE DOES NOT ENTER MONITOR PIPE.

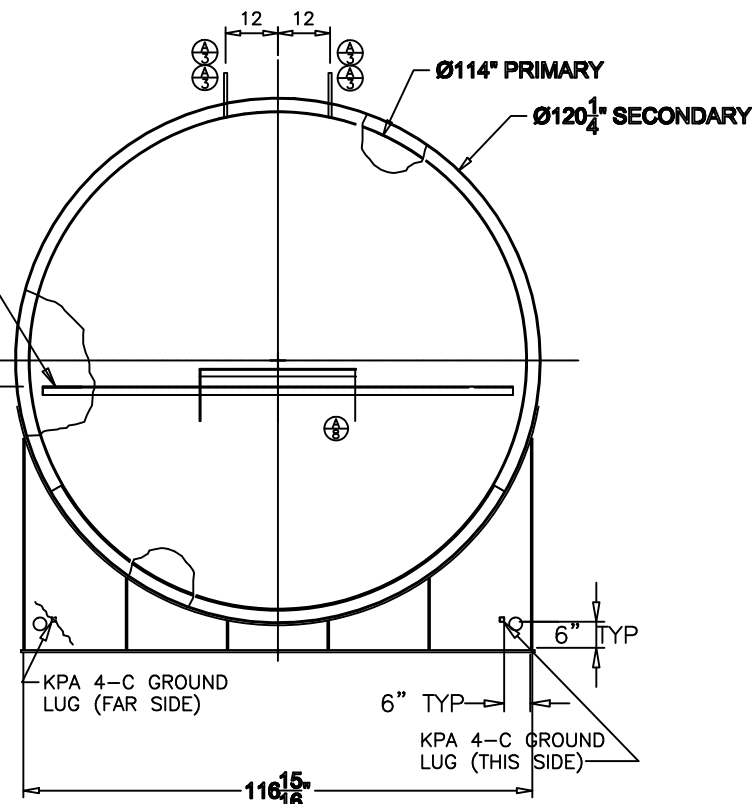

END VIEW

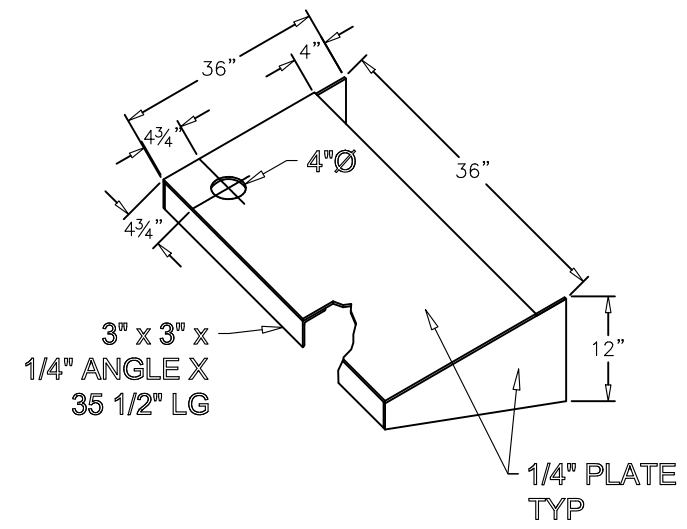

CONTENTS OF TANK

APPROVAL DRAWING  
NOT FOR FABRICATION

APPROVED AS SUBMITTED  
 APPROVED AS MARKED  
 CHANGE AND RE-SUBMIT FOR APPROVAL

\_\_\_\_\_  
SIGNATURE

\_\_\_\_\_  
DATE

AS INDICATED ABOVE, THE BUYER APPROVES THE PRODUCT DESIGN PRESENTED IN THIS DRAWING AND AGREES TO THE TERMS AND CONDITIONS IN THE SALES ORDER PROVIDED FOR THIS PRODUCT.

EST WT = 36,000 LB

MARK		QTY	DESCRIPTION
<b>PRIMARY HEADS &amp; SHELLS</b>			
MARK QTY: DESCRIPTION			
Ⓣ	4	1/4" x 60" x 120" SHEET	~SEE DETAIL
Ⓣ	1	1/4" SHEETS 60" WIDE x 359 3/8" LG	
Ⓣ	3	1/4" SHEETS 72" WIDE x 359 3/8" LG	
<b>SECONDARY HEADS &amp; SHELLS</b>			
MARK QTY: DESCRIPTION			
Ⓣ	2	3/16" X 124" CIRCLES	
Ⓣ	4	1/4" SHEETS 72" WIDE x 378 3/8" LG	
<b>FITTINGS</b>			
MARK QTY: DESCRIPTION			
Ⓣ	1	8" T.O.E. NIPPLE w/ 8" E. VENT 8oz C&B# 0368-03-8000 (PRI)	
Ⓣ	1	8" T.O.E. NIPPLE w/ 8" E. VENT 8oz C&B# 0368-03-8000 (SEC)	
Ⓣ	4	2" x 9" T.O.E NIPPLES ~SEE DETAIL~	
Ⓣ	2	4" x 9" T.O.E NIPPLES ~SEE DETAIL~	
Ⓣ	1	6" x 9" T.O.E NIPPLES ~SEE DETAIL~	
Ⓣ	1	2" HEAVY DUTY FIREGUARD COUPLING	
<b>ATTACHMENTS</b>			
MARK QTY: DESCRIPTION			
Ⓣ	1	2" SCH 40 PIPE 119" LG w/ 2" FULL COUP (MONITOR WELL)	
Ⓣ	2	"FG-120-1" SADDLES w/ KPA 4-C LUGS	
Ⓣ	4	FIREGUARD LIFT LUG 10" x 16" x 3/4"	
Ⓣ	2	SPACERS ~SEE DETAIL~	
Ⓣ	2	C6" x 8.2# x 108" LG PRIMARY HEAD BRACING	
Ⓣ	1	18" S.P. BOLTED MANWAY w/ FIBERFLEX GASKET ***** w/ 1/4" THICK COVER & 1/4" THICK FLANGE (18) 1/2"x1 1/2" GRADE 5 ZINC BOLTS (18) 1/2" GRADE 5 ZINC NUTS	
Ⓣ	2	WEARPAD 3/16" x 16 1/2" x 170	
Ⓣ	1	36" x 36" HEAD MOUNTED PLATFORM	

NOTES:

1. TANK IS TO BE FABRICATED IN ACCORDANCE WITH UL 2085 (FIREGUARD) SPECIFICATIONS. ATTACH LABELS.
2. AFTER COMPLETING PRIMARY TANK, TEST WITH 3 TO 5 PSIG AIR PRESSURE AND APPLY A LEAK DETECTION SOLUTION TO ALL WELDS. REPAIR ANY LEAKS AND RE-TEST.
3. AFTER TESTING PRIMARY TANK, COMPLETE SECONDARY TANK AND APPLY 3 TO 5 PSIG MAXIMUM AIR PRESSURE TO PRIMARY TANK. RELEASE 3 TO 5 PSIG AIR PRESSURE INTO INTERSTICE FROM PRIMARY TANK. MAINTAIN PRESSURE AND APPLY A LEAK DETECTION SOLUTION TO ALL WELDS. REPAIR ANY LEAKS AND RE-TEST.
4. AFTER PERLITE IS PUMPED INTO INTERSTICE, PLUG MUST BE SEAL WELDED.
5. TANK EXTERIOR IS TO BE SANDBLASTED & PAINTED w/ 1 COAT OF WHITE POLYURETHANE (6-8 TOTAL MILS).

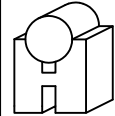

**HALL TANK COMPANY**  
NORTH LITTLE ROCK, ARKANSAS  
ENGINEERED PRODUCTS PHONE: (501) 945-3211

DRAWN BY: <b>A. BROCATO</b>	DATE: 12/2/22	APPROVED BY: ENGINEERING	DATE:
CHK'D BY:	DATE:	Q.A./Q.C.	DATE:

TITLE: 10,000 GALLON HORIZONTAL FIREGUARD  
UST: Ø114" X 228" LG (PRIMARY)

MID TEX OIL-BMT  
NEW BRAUNFELS, TX

JOB/CONTRACT NO.	DRAWING NUMBER	REV.
SCALE: NTS	SH 1 OF 1	14048-1-1

**Brauntex Materials, Inc.  
Brauntex Truck Shop**

**AST Plan Application (TCEQ-0575)  
Attachment A**

**Alternative Methods of Secondary Containment**

All the proposed tanks in this application are double-walled tanks. Double-walled tanks are manufactured to provide secondary containment for their contents. The interstitial space between the inner and outer walls serves as secondary containment. Discharges from the inner tank will flow into the outer wall that encloses it. The double-walled Roth tanks (ASTs 2-8) are certified to UL 2258 specifications and are compliant with NFPA 30 and 30A. AST 9 is a double-walled steel tank certified to UL 2085 (Fireguard) specifications. Manufacturer drawings of the proposed tanks have been included with this application.

ASTs 2-7 will each have a hose reel with nozzle on top of the tank for dispensing the maintenance oil contents. Three tanks will share a 3-inch curbed concrete pad providing approximately 30 cubic feet of impervious containment (224 gallons) for secondary containment for hose reels and potential drips; there will be another identical curbed concrete pad for the other three tanks – refer to attached drawings.

AST 8 will have a hose reel with nozzle on top of the tank for dispensing the maintenance oil contents. This tank will sit within a shallow manufactured metal pan providing approximately 1.5 cubic feet of impervious containment (12 gallons) for secondary containment for the hose reel and potential drips.

AST 9 will have double-walled piping specified. Fill lines and dispensing lines will be plumbed to the top of the tank to prevent free outward flow of the tank contents. Metal drip pans will be constructed to provide containment for potential drips at the nozzle during refueling.

The site will be subject to the Environmental Protection Agency's requirements as specified in 40 CFR Part 112 regarding Spills, Prevention, Control, and Countermeasures (SPCC). The site will maintain an SPCC Plan in accordance with applicable rules.

**AST Plan Application (TCEQ-0575)  
Attachment B**

**Scaled Drawing of Containment Structure**

Included are drawings of the proposed curbed pads providing secondary containment for hose reels associated with proposed ASTs 2-7.

**Brauntex Materials, Inc.  
Brauntex Truck Shop**

**AST Plan Application (TCEQ-0575)  
Attachment D**

**Spill and Overfill Control**

Personnel in charge of loading/unloading tanks will be trained to utilize proper techniques and preventive measures to avoid spills. The tank levels will be checked prior to loading/unloading and the operator will be present at all times during tank loading/unloading. The tank will be monitored as it is filled, either visually or in another manner, dependent upon the indicator present the tank. Additionally, at the top of AST 9, there will be an overfill prevention valve installed, which provides a positive shut-off during a pressurized fill.

**AST Plan Application (TCEQ-0575)  
Attachment E**

**Spill Response Actions**

**Education**

- (1) Be aware that different materials pollute in different amounts. Make sure that each employee knows what a “significant spill” is for each material they use, and what is the appropriate response for “significant” and “insignificant” spills. Employees should also be aware of when spill must be reported to the TCEQ.
- (2) Educate employees and subcontractors on potential dangers to humans and the environment from spills and leaks.
- (3) Hold regular meetings to discuss and reinforce appropriate disposal procedures (incorporate into regular safety meetings).
- (4) Establish a continuing education program to indoctrinate new employees.
- (5) Have contractor’s superintendent or representative oversee and enforce proper spill prevention and control measures.

**General Measures**

- (1) To the extent that the work can be accomplished safely, spills of oil, petroleum products, substances listed under 40 CFR parts 110,117, and 302, and sanitary and septic wastes should be contained and cleaned up immediately.
- (2) Store hazardous materials and wastes in covered containers and protect from vandalism.
- (3) Place a stockpile of spill cleanup materials where it will be readily accessible.

**Brauntex Materials, Inc.**  
**Brauntex Truck Shop**

- (4) Train employees in spill prevention and cleanup.
- (5) Designate responsible individuals to oversee and enforce control measures.
- (6) Spills should be covered and protected from stormwater run on during rainfall to the extent that it doesn't compromise clean up activities.
- (7) Do not bury or wash spills with water.
- (8) Store and dispose of used clean up materials, contaminated materials, and recovered spill material that is no longer suitable for the intended purpose in conformance with the provisions in applicable BMPs.
- (9) Do not allow water used for cleaning and decontamination to enter storm drains or watercourses. Collect and dispose of contaminated water in accordance with applicable regulations.
- (10) Contain water overflow or minor water spillage and do not allow it to discharge into drainage facilities or watercourses.
- (11) Place Safety Data Sheets (SDS), as well as proper storage, cleanup, and spill reporting instructions for hazardous materials stored or used on the project site in an open, conspicuous, and accessible location.
- (12) Keep waste storage areas clean, well-organized, and equipped with ample cleanup supplies as appropriate for the materials being stored. Perimeter controls, containment structures, covers, and liners should be repaired or replaced as needed to maintain proper function.

**Cleanup**

- (1) Clean up leaks and spills immediately.
- (2) Any spills from an AST facility must be removed from the controlled drainage area for disposal within 24 hours of the spill.
- (3) Use a rag for small spills on paved surfaces, a damp mop for general cleanup, and absorbent material for larger spills. If the spilled material is hazardous, then the used cleanup materials are also hazardous and must be disposed of as hazardous waste.
- (4) Never hose down or bury dry material spills. Clean up as much of the material as possible and dispose of properly. See the waste management BMPs in this section for specific information.

**Minor Spills**

**Brauntex Materials, Inc.**  
**Brauntex Truck Shop**

- (1) Minor spills typically involve small quantities of oil, gasoline, paint, etc. which can be controlled by the first responder at the discovery of the spill.
- (2) Use absorbent materials on small spills rather than hosing down or burying the spill.
- (3) Absorbent materials should be promptly removed and disposed of properly.
- (4) Follow the practice below for a minor spill:
- (5) Contain the spread of the spill.
- (6) Recover spilled materials.
- (7) Clean the contaminated area and properly dispose of contaminated materials.

**Semi-Significant Spills**

Semi-significant spills still can be controlled by the first responder along with the aid of other personnel such as laborers and the foreman, etc. This response may require the cessation of all other activities.

Spills should be cleaned up immediately:

- (1) Contain spread of the spill.
- (2) Notify the project foreman as soon as possible.
- (3) If the spill occurs on paved or impermeable surfaces, clean up using "dry" methods (absorbent materials, cat litter and/or rags). Contain the spill by encircling with absorbent materials and do not let the spill spread widely.
- (4) If the spill occurs in dirt areas, as soon as possible contain the spill by constructing an earthen dike. Dig up and properly dispose of contaminated soil.
- (5) If the spill occurs during rain, cover spill with tarps or other material to prevent contaminating runoff.

**Significant/Hazardous Spills**

For significant or hazardous spills that are in reportable quantities:

- (1) Notify the TCEQ by telephone as soon as possible and within 24 hours at 512-339-2929 (Austin) or 210-490-3096 (San Antonio) between 8 AM and 5 PM. After hours, contact the Environmental Release Hotline at 1-800-832-8224. It is the contractor's responsibility to have all emergency phone numbers at the construction site.

**Brauntex Materials, Inc.**  
**Brauntex Truck Shop**

(2) For spills of federal reportable quantities, in conformance with the requirements in 40 CFR parts 110, 119, and 302, the contractor should notify the National Response Center at (800) 424-8802.

(3) Notification should first be made by telephone and followed up with a written report.

(4) The services of a spills contractor or a Haz-Mat team should be obtained as soon as possible. Construction personnel should not attempt to clean up until the appropriate and qualified staffs have arrived at the job site.

(5) Other agencies which may need to be consulted include, but are not limited to, the City Police Department, County Sheriff Office, Fire Departments, etc.

In the event of a reportable spill, the following Emergency Response Agencies can be contacted for assistance. Always inform your supervisor of a reportable spill as soon as possible. Follow company policy when responding to an emergency.

State Emergency Response Commission	(512) 463-7727
National Response Center	(800) 424-8802
US EPA Region 6, Dallas, 24-hr Number	(866) 372-7745
National Weather Service	(281) 337-5074
TCEQ 24-hr	(800) 832-8224
TCEQ Region 13 San Antonio Office	(210) 490-3096

**Vehicle and Equipment Fueling**

(1) If fueling must occur on site, use designated areas, located away from drainage courses, to prevent the run-on of stormwater and the runoff of spills.

(2) Discourage “topping off” of fuel tanks.

(3) Always use secondary containment, such as a drain pan, when fueling to catch spills/ leaks.

(4) The fuel tank sits on an impervious concrete slab. Drain pans will be used to control spills from fueling.



# Temporary Stormwater Section

## Texas Commission on Environmental Quality

for Regulated Activities on the Edwards Aquifer Recharge Zone and Relating to 30 TAC §213.5(b)(4)(A), (B), (D)(I) and (G); Effective June 1, 1999

**To ensure that the application is administratively complete, confirm that all fields in the form are complete, verify that all requested information is provided, consistently reference the same site and contact person in all forms in the application, and ensure forms are signed by the appropriate party.**

**Note: Including all the information requested in the form and attachments contributes to more streamlined technical reviews.**

## Signature

To the best of my knowledge, the responses to this form accurately reflect all information requested concerning the proposed regulated activities and methods to protect the Edwards Aquifer. This **Temporary Stormwater Section** is hereby submitted for TCEQ review and executive director approval. The application was prepared by:

Print Name of Customer/Agent: Andrea Kidd, P.E.

TX License No. 132541 | TX Firm No. 4524

Date: 3/4/2024

Signature of Engineer/Agent:



Regulated Entity Name: Brauntex Truck Shop

## Project Information

### Potential Sources of Contamination

*Examples: Fuel storage and use, chemical storage and use, use of asphaltic products, construction vehicles tracking onto public roads, and existing solid waste.*

1. Fuels for construction equipment and hazardous substances which will be used during construction:

The following fuels and/or hazardous substances will be stored on the site: Diesel, Maintenance Oils, Used Oil

These fuels and/or hazardous substances will be stored in:

- Aboveground storage tanks with a cumulative storage capacity of less than 250 gallons will be stored on the site for less than one (1) year.
  - Aboveground storage tanks with a cumulative storage capacity between 250 gallons and 499 gallons will be stored on the site for less than one (1) year.
  - Aboveground storage tanks with a cumulative storage capacity of 500 gallons or more will be stored on the site. An Aboveground Storage Tank Facility Plan application must be submitted to the appropriate regional office of the TCEQ prior to moving the tanks onto the project.
- Fuels and hazardous substances will not be stored on the site.
2.  **Attachment A - Spill Response Actions.** A site specific description of the measures to be taken to contain any spill of hydrocarbons or hazardous substances is attached.
  3.  Temporary aboveground storage tank systems of 250 gallons or more cumulative storage capacity must be located a minimum horizontal distance of 150 feet from any domestic, industrial, irrigation, or public water supply well, or other sensitive feature.
  4.  **Attachment B - Potential Sources of Contamination.** A description of any activities or processes which may be a potential source of contamination affecting surface water quality is attached.

### ***Sequence of Construction***

5.  **Attachment C - Sequence of Major Activities.** A description of the sequence of major activities which will disturb soils for major portions of the site (grubbing, excavation, grading, utilities, and infrastructure installation) is attached. **N/A**
  - For each activity described, an estimate (in acres) of the total area of the site to be disturbed by each activity is given. **N/A**
  - For each activity described, include a description of appropriate temporary control measures and the general timing (or sequence) during the construction process that the measures will be implemented. **N/A**
6.  Name the receiving water(s) at or near the site which will be disturbed or which will receive discharges from disturbed areas of the project: **N/A**

### ***Temporary Best Management Practices (TBMPs)***

*Erosion control examples: tree protection, interceptor swales, level spreaders, outlet stabilization, blankets or matting, mulch, and sod. Sediment control examples: stabilized construction exit, silt fence, filter dikes, rock berms, buffer strips, sediment traps, and sediment basins. Please refer to the Technical Guidance Manual for guidelines and specifications. All structural BMPs must be shown on the site plan.*

7.  **Attachment D – Temporary Best Management Practices and Measures.** TBMPs and measures will prevent pollution of surface water, groundwater, and stormwater. The construction-phase BMPs for erosion and sediment controls have been designed to

retain sediment on site to the extent practicable. The following information is attached:  
**N/A**

- A description of how BMPs and measures will prevent pollution of surface water, groundwater or stormwater that originates upgradient from the site and flows across the site.
  - A description of how BMPs and measures will prevent pollution of surface water or groundwater that originates on-site or flows off site, including pollution caused by contaminated stormwater runoff from the site.
  - A description of how BMPs and measures will prevent pollutants from entering surface streams, sensitive features, or the aquifer.
  - A description of how, to the maximum extent practicable, BMPs and measures will maintain flow to naturally-occurring sensitive features identified in either the geologic assessment, TCEQ inspections, or during excavation, blasting, or construction.
8.  The temporary sealing of a naturally-occurring sensitive feature which accepts recharge to the Edwards Aquifer as a temporary pollution abatement measure during active construction should be avoided.
- Attachment E - Request to Temporarily Seal a Feature.** A request to temporarily seal a feature is attached. The request includes justification as to why no reasonable and practicable alternative exists for each feature.
  - There will be no temporary sealing of naturally-occurring sensitive features on the site.
9.  **Attachment F - Structural Practices.** A description of the structural practices that will be used to divert flows away from exposed soils, to store flows, or to otherwise limit runoff discharge of pollutants from exposed areas of the site is attached. Placement of structural practices in floodplains has been avoided. **N/A**
10.  **Attachment G - Drainage Area Map.** A drainage area map supporting the following requirements is attached: **N/A**
- For areas that will have more than 10 acres within a common drainage area disturbed at one time, a sediment basin will be provided.
  - For areas that will have more than 10 acres within a common drainage area disturbed at one time, a smaller sediment basin and/or sediment trap(s) will be used.
  - For areas that will have more than 10 acres within a common drainage area disturbed at one time, a sediment basin or other equivalent controls are not attainable, but other TBMPs and measures will be used in combination to protect down slope and side slope boundaries of the construction area.
  - There are no areas greater than 10 acres within a common drainage area that will be disturbed at one time. A smaller sediment basin and/or sediment trap(s) will be used in combination with other erosion and sediment controls within each disturbed drainage area.

- There are no areas greater than 10 acres within a common drainage area that will be disturbed at one time. Erosion and sediment controls other than sediment basins or sediment traps within each disturbed drainage area will be used.
11.  **Attachment H - Temporary Sediment Pond(s) Plans and Calculations.** Temporary sediment pond or basin construction plans and design calculations for a proposed temporary BMP or measure have been prepared by or under the direct supervision of a Texas Licensed Professional Engineer. All construction plans and design information must be signed, sealed, and dated by the Texas Licensed Professional Engineer. Construction plans for the proposed temporary BMPs and measures are attached.
- N/A
12.  **Attachment I - Inspection and Maintenance for BMPs.** A plan for the inspection of each temporary BMP(s) and measure(s) and for their timely maintenance, repairs, and, if necessary, retrofit is attached. A description of the documentation procedures, recordkeeping practices, and inspection frequency are included in the plan and are specific to the site and/or BMP. **N/A**
13.  All control measures must be properly selected, installed, and maintained in accordance with the manufacturer's specifications and good engineering practices. If periodic inspections by the applicant or the executive director, or other information indicate a control has been used inappropriately, or incorrectly, the applicant must replace or modify the control for site situations. **N/A**
14.  If sediment escapes the construction site, off-site accumulations of sediment must be removed at a frequency sufficient to minimize offsite impacts to water quality (e.g., fugitive sediment in street being washed into surface streams or sensitive features by the next rain). **N/A**
15.  Sediment must be removed from sediment traps or sedimentation ponds not later than when design capacity has been reduced by 50%. A permanent stake will be provided that can indicate when the sediment occupies 50% of the basin volume. **N/A**
16.  Litter, construction debris, and construction chemicals exposed to stormwater shall be prevented from becoming a pollutant source for stormwater discharges (e.g., screening outfalls, picked up daily).

### ***Soil Stabilization Practices***

*Examples: establishment of temporary vegetation, establishment of permanent vegetation, mulching, geotextiles, sod stabilization, vegetative buffer strips, protection of trees, or preservation of mature vegetation.*

17.  **Attachment J - Schedule of Interim and Permanent Soil Stabilization Practices.** A schedule of the interim and permanent soil stabilization practices for the site is attached. **N/A – No grading expected for this site.**

18.  Records must be kept at the site of the dates when major grading activities occur, the dates when construction activities temporarily or permanently cease on a portion of the site, and the dates when stabilization measures are initiated. **N/A**
19.  Stabilization practices must be initiated as soon as practicable where construction activities have temporarily or permanently ceased. **N/A**

### ***Administrative Information***

20.  All structural controls will be inspected and maintained according to the submitted and approved operation and maintenance plan for the project. **N/A**
21.  If any geologic or manmade features, such as caves, faults, sinkholes, etc., are discovered, all regulated activities near the feature will be immediately suspended. The appropriate TCEQ Regional Office shall be immediately notified. Regulated activities must cease and not continue until the TCEQ has reviewed and approved the methods proposed to protect the aquifer from any adverse impacts.
22.  Silt fences, diversion berms, and other temporary erosion and sediment controls will be constructed and maintained as appropriate to prevent pollutants from entering sensitive features discovered during construction. **N/A**

**Brauntex Materials, Inc.,  
Brauntex Truck Shop**

**Temporary Stormwater Section (TCEQ-0602)  
Attachment A**

**Spill Response Actions**

**Education**

- (1) Be aware that different materials pollute in different amounts. Make sure that each employee knows what a “significant spill” is for each material they use, and what is the appropriate response for “significant” and “insignificant” spills. Employees should also be aware of when spill must be reported to the TCEQ.
- (2) Educate employees and subcontractors on potential dangers to humans and the environment from spills and leaks.
- (3) Hold regular meetings to discuss and reinforce appropriate disposal procedures (incorporate into regular safety meetings).
- (4) Establish a continuing education program to indoctrinate new employees.
- (5) Have contractor’s superintendent or representative oversee and enforce proper spill prevention and control measures.

**General Measures**

- (1) To the extent that the work can be accomplished safely, spills of oil, petroleum products, substances listed under 40 CFR parts 110,117, and 302, and sanitary and septic wastes should be contained and cleaned up immediately.
- (2) Store hazardous materials and wastes in covered containers and protect from vandalism.
- (3) Place a stockpile of spill cleanup materials where it will be readily accessible.
- (4) Train employees in spill prevention and cleanup.
- (5) Designate responsible individuals to oversee and enforce control measures.
- (6) Spills should be covered and protected from stormwater run on during rainfall to the extent that it doesn’t compromise clean up activities.
- (7) Do not bury or wash spills with water.

**Brauntex Materials, Inc.,  
Brauntex Truck Shop**

(8) Store and dispose of used clean up materials, contaminated materials, and recovered spill material that is no longer suitable for the intended purpose in conformance with the provisions in applicable BMPs.

(9) Do not allow water used for cleaning and decontamination to enter storm drains or watercourses. Collect and dispose of contaminated water in accordance with applicable regulations.

(10) Contain water overflow or minor water spillage and do not allow it to discharge into drainage facilities or watercourses.

(11) Place Safety Data Sheets (SDS), as well as proper storage, cleanup, and spill reporting instructions for hazardous materials stored or used on the project site in an open, conspicuous, and accessible location.

(12) Keep waste storage areas clean, well-organized, and equipped with ample cleanup supplies as appropriate for the materials being stored. Perimeter controls, containment structures, covers, and liners should be repaired or replaced as needed to maintain proper function.

**Cleanup**

(1) Clean up leaks and spills immediately.

(2) Any spills from an AST facility must be removed from the controlled drainage area for disposal within 24 hours of the spill.

(3) Use a rag for small spills on paved surfaces, a damp mop for general cleanup, and absorbent material for larger spills. If the spilled material is hazardous, then the used cleanup materials are also hazardous and must be disposed of as hazardous waste.

(4) Never hose down or bury dry material spills. Clean up as much of the material as possible and dispose of properly. See the waste management BMPs in this section for specific information.

**Minor Spills**

(1) Minor spills typically involve small quantities of oil, gasoline, paint, etc. which can be controlled by the first responder at the discovery of the spill.

(2) Use absorbent materials on small spills rather than hosing down or burying the spill.

(3) Absorbent materials should be promptly removed and disposed of properly.

(4) Follow the practice below for a minor spill:

(5) Contain the spread of the spill.



**Brauntex Materials, Inc.,  
Brauntex Truck Shop**

(6) Recover spilled materials.

(7) Clean the contaminated area and properly dispose of contaminated materials.

**Semi-Significant Spills**

Semi-significant spills still can be controlled by the first responder along with the aid of other personnel such as laborers and the foreman, etc. This response may require the cessation of all other activities.

Spills should be cleaned up immediately:

(1) Contain spread of the spill.

(2) Notify the project foreman as soon as possible.

(3) If the spill occurs on paved or impermeable surfaces, clean up using "dry" methods (absorbent materials, cat litter and/or rags). Contain the spill by encircling with absorbent materials and do not let the spill spread widely.

(4) If the spill occurs in dirt areas, as soon as possible contain the spill by constructing an earthen dike. Dig up and properly dispose of contaminated soil.

(5) If the spill occurs during rain, cover spill with tarps or other material to prevent contaminating runoff.

**Significant/Hazardous Spills**

For significant or hazardous spills that are in reportable quantities:

(1) Notify the TCEQ by telephone as soon as possible and within 24 hours at 512-339-2929 (Austin) or 210-490-3096 (San Antonio) between 8 AM and 5 PM. After hours, contact the Environmental Release Hotline at 1-800-832-8224. It is the contractor's responsibility to have all emergency phone numbers at the construction site.

(2) For spills of federal reportable quantities, in conformance with the requirements in 40 CFR parts 110,119, and 302, the contractor should notify the National Response Center at (800) 424-8802.

(3) Notification should first be made by telephone and followed up with a written report.

(4) The services of a spills contractor or a Haz-Mat team should be obtained as soon as possible. Construction personnel should not attempt to clean up until the appropriate and qualified staffs have arrived at the job site.

**Brauntex Materials, Inc.,  
Brauntex Truck Shop**

(5) Other agencies which may need to be consulted include, but are not limited to, the City Police Department, County Sheriff Office, Fire Departments, etc.

In the event of a reportable spill, the following Emergency Response Agencies can be contacted for assistance. Always inform your supervisor of a reportable spill as soon as possible. Follow company policy when responding to an emergency.

State Emergency Response Commission	(512) 463-7727
National Response Center	(800) 424-8802
US EPA Region 6, Dallas, 24-hr Number	(866) 372-7745
National Weather Service	(281) 337-5074
TCEQ 24-hr	(800) 832-8224
TCEQ Region 13 San Antonio Office	(210) 490-3096

**Vehicle and Equipment Fueling**

- (1) If fueling must occur on site, use designated areas, located away from drainage courses, to prevent the run-on of stormwater and the runoff of spills.
- (2) Discourage “topping off” of fuel tanks.
- (3) Always use secondary containment, such as a drain pan, when fueling to catch spills/ leaks.
- (4) Fueling will occur over the impervious concrete slab. Drain pans, curbing and sumps will be used to control spills from fueling.

**Portable Toilet BMPs:**

If portable toilets are used at this site, they will be handled in accordance with the following guidelines:

- A licensed waste collector should service all the toilets. **The following tasks will be performed by the portable toilet supplier:**
  - Empty portable toilets before transporting them.
  - Securely fasten the toilets to the transport truck.
  - Use hand trucks, dollies, and power tailgates whenever possible.
  - Suppliers should carry bleach for disinfection in the event of a spill or leak.
  - Inspect the toilets frequently for leaks and have the units serviced and sanitized at time intervals that will maintain sanitary conditions of each toilet.
- Locate portable toilets at least 20 feet from the nearest storm-drain inlet or sensitive-feature filter strip area
- A berm will be constructed around all portable toilet facilities.
- Prepare a level ground surface with clear access to the toilets.

Secure all portable toilets to prevent tipping by accident, weather, or vandalism.

**Brauntex Materials, Inc.,  
Brauntex Truck Shop**

**DETAILED TELEPHONE SPILL REPORT FORM**

Date of Incident: \_\_\_\_\_

Location of Incident: \_\_\_\_\_

Description of material spilled: \_\_\_\_\_

Quantity of material spilled: \_\_\_\_\_

Cause of spill: \_\_\_\_\_

Authorities notified: \_\_\_\_\_

Remediation/clean-up action: \_\_\_\_\_

\_\_\_\_\_

\_\_\_\_\_

\_\_\_\_\_

Corrective measures taken for prevention of reoccurrence: \_\_\_\_\_

\_\_\_\_\_

\_\_\_\_\_

\_\_\_\_\_

Signature: \_\_\_\_\_

Notes: \_\_\_\_\_

\_\_\_\_\_

\_\_\_\_\_

\_\_\_\_\_

Emergency Number for the National Response Center 1-800-424-8802

**Brauntex Materials, Inc.,  
Brauntex Truck Shop**

**Temporary Stormwater Section (TCEQ-0602)  
Attachment B**

**Potential Sources of Contamination**

Potential sources of contamination are the soil, fuels and lubricants from vehicles and trash/debris items.

**Temporary Stormwater Section (TCEQ-0602)  
Attachments C, D, E, F, G, H, I & J**

The Temporary Stormwater Attachments C, D, E, F, G, H, I, and J are not necessary for this project as no grading activities are occurring as a result of this AST Plan Modification application.



# TCEQ Core Data Form

For detailed instructions on completing this form, please read the Core Data Form Instructions or call 512-239-5175.

## SECTION I: General Information

1. Reason for Submission <i>(If other is checked please describe in space provided.)</i>		
<input type="checkbox"/> New Permit, Registration or Authorization <i>(Core Data Form should be submitted with the program application.)</i>		
<input type="checkbox"/> Renewal <i>(Core Data Form should be submitted with the renewal form)</i>		<input checked="" type="checkbox"/> Other    AST Plan Modification
2. Customer Reference Number <i>(if issued)</i>	Follow this link to search for CN or RN numbers in Central Registry**	3. Regulated Entity Reference Number <i>(if issued)</i>
CN 600618581		RN 100853555

## SECTION II: Customer Information

4. General Customer Information		5. Effective Date for Customer Information Updates (mm/dd/yyyy)		
<input type="checkbox"/> New Customer <input type="checkbox"/> Update to Customer Information <input type="checkbox"/> Change in Regulated Entity Ownership <input type="checkbox"/> Change in Legal Name <i>(Verifiable with the Texas Secretary of State or Texas Comptroller of Public Accounts)</i>				
<i>The Customer Name submitted here may be updated automatically based on what is current and active with the Texas Secretary of State (SOS) or Texas Comptroller of Public Accounts (CPA).</i>				
6. Customer Legal Name <i>(If an individual, print last name first: eg: Doe, John)</i>			<i>If new Customer, enter previous Customer below:</i>	
Brauntex Materials, Inc.				
7. TX SOS/CPA Filing Number	8. TX State Tax ID (11 digits)	9. Federal Tax ID (9 digits)	10. DUNS Number <i>(if applicable)</i>	
0023295700	17415607724			
11. Type of Customer:	<input checked="" type="checkbox"/> Corporation	<input type="checkbox"/> Individual	Partnership: <input type="checkbox"/> General <input type="checkbox"/> Limited	
Government: <input type="checkbox"/> City <input type="checkbox"/> County <input type="checkbox"/> Federal <input type="checkbox"/> Local <input type="checkbox"/> State <input type="checkbox"/> Other		<input type="checkbox"/> Sole Proprietorship	<input type="checkbox"/> Other:	
12. Number of Employees	13. Independently Owned and Operated?			
<input type="checkbox"/> 0-20 <input checked="" type="checkbox"/> 21-100 <input type="checkbox"/> 101-250 <input type="checkbox"/> 251-500 <input type="checkbox"/> 501 and higher	<input checked="" type="checkbox"/> Yes <input type="checkbox"/> No			
14. Customer Role <i>(Proposed or Actual) – as it relates to the Regulated Entity listed on this form. Please check one of the following</i>				
<input type="checkbox"/> Owner <input type="checkbox"/> Operator <input checked="" type="checkbox"/> Owner & Operator <input type="checkbox"/> Other: <input type="checkbox"/> Occupational Licensee <input type="checkbox"/> Responsible Party <input type="checkbox"/> VCP/BSA Applicant				
15. Mailing Address:	1504 Wald Rd			
	City	New Braunfels	State	TX
	ZIP	78132	ZIP + 4	
16. Country Mailing Information <i>(if outside USA)</i>			17. E-Mail Address <i>(if applicable)</i>	
			wdfischer@brauntexmaterials.com	
18. Telephone Number	19. Extension or Code	20. Fax Number <i>(if applicable)</i>		
(830) 625-6276		(830) 620-7995		

## SECTION III: Regulated Entity Information

21. General Regulated Entity Information <i>(If "New Regulated Entity" is selected, a new permit application is also required.)</i>	
<input type="checkbox"/> New Regulated Entity <input checked="" type="checkbox"/> Update to Regulated Entity Name <input type="checkbox"/> Update to Regulated Entity Information	
<i>The Regulated Entity Name submitted may be updated, in order to meet TCEQ Core Data Standards (removal of organizational endings such as Inc, LP, or LLC).</i>	
22. Regulated Entity Name <i>(Enter name of the site where the regulated action is taking place.)</i>	
Brauntex Truck Shop	

23. Street Address of the Regulated Entity: <i>(No PO Boxes)</i>	1870 Wald Road							
	City	New Braunfels	State	TX	ZIP	78132	ZIP + 4	
24. County	Comal							

If no Street Address is provided, fields 25-28 are required.

25. Description to Physical Location:									
26. Nearest City				State		Nearest ZIP Code			
New Braunfels				Texas		78132			
<i>Latitude/Longitude are required and may be added/updated to meet TCEQ Core Data Standards. (Geocoding of the Physical Address may be used to supply coordinates where none have been provided or to gain accuracy).</i>									
27. Latitude (N) In Decimal:		29.680982°		28. Longitude (W) In Decimal:		- 98.170094°			
Degrees	Minutes	Seconds	Degrees	Minutes	Seconds				
29	40	51.53	98	10	12.34				
29. Primary SIC Code (4 digits)		30. Secondary SIC Code (4 digits)		31. Primary NAICS Code (5 or 6 digits)		32. Secondary NAICS Code(5 or 6 digits)			
2951				324121					
33. What is the Primary Business of this entity? <i>(Do not repeat the SIC or NAICS description.)</i>									
Construction Materials									
34. Mailing Address:		1504 Wald Rd							
		City	New Braunfels	State	TX	ZIP	78132	ZIP + 4	
35. E-Mail Address:		wdfischer@brauntexmaterials.com							
36. Telephone Number			37. Extension or Code		38. Fax Number <i>(if applicable)</i>				
(830) 625-6276					(830) 620-7995				

39. TCEQ Programs and ID Numbers Check all Programs and write in the permits/registration numbers that will be affected by the updates submitted on this form. See the Core Data Form instructions for additional guidance.

<input type="checkbox"/> Dam Safety	<input type="checkbox"/> Districts	<input checked="" type="checkbox"/> Edwards Aquifer	<input type="checkbox"/> Emissions Inventory Air	<input type="checkbox"/> Industrial Hazardous Waste
		EAPP ID 13-02042601		
<input type="checkbox"/> Municipal Solid Waste	<input type="checkbox"/> New Source Review Air	<input type="checkbox"/> OSSF	<input type="checkbox"/> Petroleum Storage Tank	<input type="checkbox"/> PWS
<input type="checkbox"/> Sludge	<input type="checkbox"/> Storm Water	<input type="checkbox"/> Title V Air	<input type="checkbox"/> Tires	<input type="checkbox"/> Used Oil
<input type="checkbox"/> Voluntary Cleanup	<input type="checkbox"/> Wastewater	<input type="checkbox"/> Wastewater Agriculture	<input type="checkbox"/> Water Rights	<input type="checkbox"/> Other:

## SECTION IV: Preparer Information

40. Name:	Andrea Kidd, P.E.		41. Title:	Project Engineer
42. Telephone Number	43. Ext./Code	44. Fax Number	45. E-Mail Address	
(830) 249-8284		(830) 249-0221	akidd@westwardenv.com	

## SECTION V: Authorized Signature

46. By my signature below, I certify, to the best of my knowledge, that the information provided in this form is true and complete, and that I have signature authority to submit this form on behalf of the entity specified in Section II, Field 6 and/or as required for the updates to the ID numbers identified in field 39.

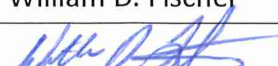
Company:	Brauntex Materials, Inc.	Job Title:	President
Name <i>(In Print)</i> :	William D. Fischer	Phone:	(830) 625-6276
Signature:		Date:	2-15-24

**Agent Authorization Form**  
For Required Signature  
Edwards Aquifer Protection Program  
Relating to 30 TAC Chapter 213  
Effective June 1, 1999

I \_\_\_\_\_ William D. Fischer \_\_\_\_\_,  
Print Name

\_\_\_\_\_ President \_\_\_\_\_,  
Title - Owner/President/Other

of \_\_\_\_\_ Brauntex Materials, Inc. \_\_\_\_\_,  
Corporation/Partnership/Entity Name

have authorized \_\_\_\_\_ Curt G. Campbell, P.E., Gary D. Nicholls, P.E., Andrea Kidd, P.E.,  
Vance Houy, P.E., Chelsy Houy, P.E., and Nicolas E. Mercado, P.E. \_\_\_\_\_  
Print Name of Agent/Engineer

of \_\_\_\_\_ Westward Environmental, Inc. \_\_\_\_\_  
Print Name of Firm

to represent and act on the behalf of the above named Corporation, Partnership, or Entity for the purpose of preparing and submitting this plan application to the Texas Commission on Environmental Quality (TCEQ) for the review and approval consideration of regulated activities.

I also understand that:

1. The applicant is responsible for compliance with 30 Texas Administrative Code Chapter 213 and any condition of the TCEQ's approval letter. The TCEQ is authorized to assess administrative penalties of up to \$10,000 per day per violation.
2. For those submitting an application who are not the property owner, but who have the right to control and possess the property, additional authorization is required from the owner.
3. Application fees are due and payable at the time the application is submitted. The application fee must be sent to the TCEQ cashier or to the appropriate regional office. The application will not be considered until the correct fee is received by the commission.
4. A notarized copy of the Agent Authorization Form must be provided for the person preparing the application, and this form must accompany the completed application.
5. No person shall commence any regulated activity on the Edwards Aquifer Recharge Zone, Contributing Zone or Transition Zone until the appropriate application for the activity has been filed with and approved by the Executive Director.



SIGNATURE PAGE:

*[Handwritten Signature]*

Applicant's Signature

*2-15-24*

Date

THE STATE OF Texas §

County of Comal §

BEFORE ME, the undersigned authority, on this day personally appeared William D. Fischer known to me to be the person whose name is subscribed to the foregoing instrument, and acknowledged to me that (s)he executed same for the purpose and consideration therein expressed.

GIVEN under my hand and seal of office on this 15 day of February, 2024

*[Handwritten Signature]*

NOTARY PUBLIC

Andrea S. Kidd

Typed or Printed Name of Notary

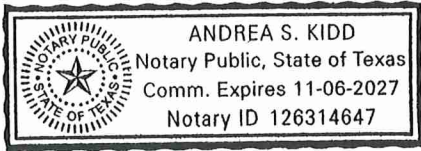

MY COMMISSION EXPIRES: 11-06-2027

# Application Fee Form

## Texas Commission on Environmental Quality

Name of Proposed Regulated Entity: Brauntex Shop

Regulated Entity Location: 1870 Wald Road, New Braunfels, Texas 78132

Name of Customer: Brauntex Materials, Inc.

Contact Person: Will Fischer

Phone: (830) 625-6276

Customer Reference Number (if issued): CN 600618581

Regulated Entity Reference Number (if issued): RN 100853555

### Austin Regional Office (3373)

Hays

Travis

Williamson

### San Antonio Regional Office (3362)

Bexar

Medina

Uvalde

Comal

Kinney

Application fees must be paid by check, certified check, or money order, payable to the **Texas Commission on Environmental Quality**. Your canceled check will serve as your receipt. **This form must be submitted with your fee payment.** This payment is being submitted to:

Austin Regional Office

San Antonio Regional Office

Mailed to: TCEQ - Cashier **ePay**

Overnight Delivery to: TCEQ - Cashier

Revenues Section

12100 Park 35 Circle

Mail Code 214

Building A, 3rd Floor

P.O. Box 13088

Austin, TX 78753

Austin, TX 78711-3088

(512)239-0357

### Site Location (Check All That Apply):

Recharge Zone

Contributing Zone

Transition Zone

<i>Type of Plan</i>	<i>Size</i>	<i>Fee Due</i>
Water Pollution Abatement Plan, Contributing Zone Plan: One Single Family Residential Dwelling	Acres	\$
Water Pollution Abatement Plan, Contributing Zone Plan: Multiple Single Family Residential and Parks	Acres	\$
Water Pollution Abatement Plan, Contributing Zone Plan: Non-residential	Acres	\$
Sewage Collection System	L.F.	\$
Lift Stations without sewer lines	Acres	\$
Underground or Aboveground Storage Tank Facility	<u>8</u> Tanks	\$ <u>5,200</u>
Piping System(s)(only)	Each	\$
Exception	Each	\$
Extension of Time	Each	\$

Signature: 

Date: 2-15-24

# Application Fee Schedule

Texas Commission on Environmental Quality

Edwards Aquifer Protection Program 30 TAC Chapter 213 (effective 05/01/2008)

## ***Water Pollution Abatement Plans and Modifications***

### ***Contributing Zone Plans and Modifications***

<b><i>Project</i></b>	<b><i>Project Area in Acres</i></b>	<b><i>Fee</i></b>
One Single Family Residential Dwelling	< 5	\$650
Multiple Single Family Residential and Parks	< 5	\$1,500
	5 < 10	\$3,000
	10 < 40	\$4,000
	40 < 100	\$6,500
	100 < 500	\$8,000
	≥ 500	\$10,000
Non-residential (Commercial, industrial, institutional, multi-family residential, schools, and other sites where regulated activities will occur)	< 1	\$3,000
	1 < 5	\$4,000
	5 < 10	\$5,000
	10 < 40	\$6,500
	40 < 100	\$8,000
	≥ 100	\$10,000

### ***Organized Sewage Collection Systems and Modifications***

<b><i>Project</i></b>	<b><i>Cost per Linear Foot</i></b>	<b><i>Minimum Fee- Maximum Fee</i></b>
Sewage Collection Systems	\$0.50	\$650 - \$6,500

### ***Underground and Aboveground Storage Tank System Facility Plans and Modifications***

<b><i>Project</i></b>	<b><i>Cost per Tank or Piping System</i></b>	<b><i>Minimum Fee- Maximum Fee</i></b>
Underground and Aboveground Storage Tank Facility	\$650	\$650 - \$6,500

### ***Exception Requests***

<b><i>Project</i></b>	<b><i>Fee</i></b>
Exception Request	\$500

### ***Extension of Time Requests***

<b><i>Project</i></b>	<b><i>Fee</i></b>
Extension of Time Request	\$150