

**SEWAGE COLLECTION SYSTEM PLAN**  
**FOR**  
**VERAMENDI PRECINCTS 18-2 & 19-1**

**DECEMBER 4, 2023**

**Prepared For:**  
**Veramendi PE-Emerald LLC**  
**387 W Mill St, Ste 108**  
**New Braunfels, TX, 78130**

**Prepared By:**  
**LJA ENGINEERING, INC.**  
**TBPE Firm Registration No. F-1386**  
**9830 Colonnade Blvd Ste 300**  
**San Antonio, Texas 78256**  
**Phone (210) 503-2700**

**LJA FILE NO. SA3856-0401-0402**

# Texas Commission on Environmental Quality

## Edwards Aquifer Application Cover Page

---

### Our Review of Your Application

**The Edwards Aquifer Program staff conducts an administrative and technical review of all applications. The turnaround time for administrative review can be up to 30 days as outlined in 30 TAC 213.4(e). Generally administrative completeness is determined during the intake meeting or within a few days of receipt. The turnaround time for technical review of an administratively complete Edwards Aquifer application is 90 days as outlined in 30 TAC 213.4(e). Please know that the review and approval time is directly impacted by the quality and completeness of the initial application that is received. In order to conduct a timely review, it is imperative that the information provided in an Edwards Aquifer application include final plans, be accurate, complete, and in compliance with [30 TAC 213](#).**

### Administrative Review

1. [Edwards Aquifer applications](#) must be deemed administratively complete before a technical review can begin. To be considered administratively complete, the application must contain completed forms and attachments, provide the requested information, and meet all the site plan requirements. The submitted application and plan sheets should be final plans. Please submit one full-size set of plan sheets with the original application, and half-size sets with the additional copies.

To ensure that all applicable documents are included in the application, the program has developed tools to guide you and web pages to provide all forms, checklists, and guidance. Please visit the below website for assistance: <http://www.tceq.texas.gov/field/eapp>.

2. This Edwards Aquifer Application Cover Page form (certified by the applicant or agent) must be included in the application and brought to the administrative review meeting.
3. Administrative reviews are scheduled with program staff who will conduct the review. Applicants or their authorized agent should call the appropriate regional office, according to the county in which the project is located, to schedule a review. The average meeting time is one hour.
4. In the meeting, the application is examined for administrative completeness. Deficiencies will be noted by staff and emailed or faxed to the applicant and authorized agent at the end of the meeting, or shortly after. Administrative deficiencies will cause the application to be deemed incomplete and returned.

An appointment should be made to resubmit the application. The application is re-examined to ensure all deficiencies are resolved. The application will only be deemed administratively complete when all administrative deficiencies are addressed.

5. If an application is received by mail, courier service, or otherwise submitted without a review meeting, the administrative review will be conducted within 30 days. The applicant and agent will be contacted with the results of the administrative review. If the application is found to be administratively incomplete, it can be retrieved from the regional office or returned by regular mail. If returned by mail, the regional office may require arrangements for return shipping.
6. If the geologic assessment was completed before October 1, 2004 and the site contains “possibly sensitive” features, the assessment must be updated in accordance with the *Instructions to Geologists* (TCEQ-0585 Instructions).

### Technical Review

1. When an application is deemed administratively complete, the technical review period begins. The regional office will distribute copies of the application to the identified affected city, county, and groundwater conservation district whose jurisdiction includes the subject site. These entities and the public have 30 days to provide comments on the application to the regional office. All comments received are reviewed by TCEQ.
2. A site assessment is usually conducted as part of the technical review, to evaluate the geologic assessment and observe existing site conditions. The site must be accessible to our staff. The site boundaries should be

clearly marked, features identified in the geologic assessment should be flagged, roadways marked and the alignment of the Sewage Collection System and manholes should be staked at the time the application is submitted. If the site is not marked the application may be returned.

3. We evaluate the application for technical completeness and contact the applicant and agent via Notice of Deficiency (NOD) to request additional information and identify technical deficiencies. There are two deficiency response periods available to the applicant. There are 14 days to resolve deficiencies noted in the first NOD. If a second NOD is issued, there is an additional 14 days to resolve deficiencies. If the response to the second notice is not received, is incomplete or inadequate, or provides new information that is incomplete or inadequate, the application must be withdrawn or will be denied. Please note that because the technical review is underway, whether the application is withdrawn or denied **the application fee will be forfeited**.
4. The program has 90 calendar days to complete the technical review of the application. If the application is technically adequate, such that it complies with the Edwards Aquifer rules, and is protective of the Edwards Aquifer during and after construction, an approval letter will be issued. Construction or other regulated activity may not begin until an approval is issued.

**Mid-Review Modifications**

It is important to have final site plans prior to beginning the permitting process with TCEQ to avoid delays.

Occasionally, circumstances arise where you may have significant design and/or site plan changes after your Edwards Aquifer application has been deemed administratively complete by TCEQ. This is considered a “Mid-Review Modification”. Mid-Review Modifications may require redistribution of an application that includes the proposed modifications for public comment.

If you are proposing a Mid-Review Modification, two options are available:

- If the technical review has begun your application can be denied/withdrawn, your fees will be forfeited, and the plan will have to be resubmitted.
- TCEQ can continue the technical review of the application as it was submitted, and a modification application can be submitted at a later time.

If the application is denied/withdrawn, the resubmitted application will be subject to the administrative and technical review processes and will be treated as a new application. The application will be redistributed to the affected jurisdictions.

Please contact the regional office if you have questions. If your project is located in Williamson, Travis, or Hays County, contact TCEQ’s Austin Regional Office at 512-339-2929. If your project is in Comal, Bexar, Medina, Uvalde, or Kinney County, contact TCEQ’s San Antonio Regional Office at 210-490-3096

Please fill out all required fields below and submit with your application.

<b>1. Regulated Entity Name:</b> Veramendi Precincts 18-2 & 19-1				<b>2. Regulated Entity No.:</b>					
<b>3. Customer Name:</b> Veramendi PE-Emerald LLC				<b>4. Customer No.:</b>					
<b>5. Project Type:</b> (Please circle/check one)	New		Modification			Extension		Exception	
<b>6. Plan Type:</b> (Please circle/check one)	WPAP	CZP	SCS	UST	AST	EXP	EXT	Technical Clarification	Optional Enhanced Measures
<b>7. Land Use:</b> (Please circle/check one)	Residential		Non-residential			<b>8. Site (acres):</b>		80.45 ac	
<b>9. Application Fee:</b>				<b>10. Permanent BMP(s):</b>			Extended Detention Water Quality Pond & Vegetative Filter Strips		
<b>11. SCS (Linear Ft.):</b>	9,625.62		<b>12. AST/UST (No. Tanks):</b>						
<b>13. County:</b>	Comal		<b>14. Watershed:</b>			Comal River-Guadalupe River			

# Application Distribution

Instructions: Use the table below to determine the number of applications required. One original and one copy of the application, plus additional copies (as needed) for each affected incorporated city, county, and groundwater conservation district are required. Linear projects or large projects, which cross into multiple jurisdictions, can require additional copies. Refer to the “Texas Groundwater Conservation Districts within the EAPP Boundaries” map found at:

[http://www.tceq.texas.gov/assets/public/compliance/field\\_ops/eapp/EAPP%20GWCD%20map.pdf](http://www.tceq.texas.gov/assets/public/compliance/field_ops/eapp/EAPP%20GWCD%20map.pdf)

For more detailed boundaries, please contact the conservation district directly.

<b>Austin Region</b>			
<b>County:</b>	<b>Hays</b>	<b>Travis</b>	<b>Williamson</b>
Original (1 req.)	—	—	—
Region (1 req.)	—	—	—
County(ies)	—	—	—
Groundwater Conservation District(s)	<input type="checkbox"/> Edwards Aquifer Authority <input type="checkbox"/> Barton Springs/ Edwards Aquifer <input type="checkbox"/> Hays Trinity <input type="checkbox"/> Plum Creek	<input type="checkbox"/> Barton Springs/ Edwards Aquifer	NA
City(ies) Jurisdiction	<input type="checkbox"/> Austin <input type="checkbox"/> Buda <input type="checkbox"/> Dripping Springs <input type="checkbox"/> Kyle <input type="checkbox"/> Mountain City <input type="checkbox"/> San Marcos <input type="checkbox"/> Wimberley <input type="checkbox"/> Woodcreek	<input type="checkbox"/> Austin <input type="checkbox"/> Bee Cave <input type="checkbox"/> Pflugerville <input type="checkbox"/> Rollingwood <input type="checkbox"/> Round Rock <input type="checkbox"/> Sunset Valley <input type="checkbox"/> West Lake Hills	<input type="checkbox"/> Austin <input type="checkbox"/> Cedar Park <input type="checkbox"/> Florence <input type="checkbox"/> Georgetown <input type="checkbox"/> Jerrell <input type="checkbox"/> Leander <input type="checkbox"/> Liberty Hill <input type="checkbox"/> Pflugerville <input type="checkbox"/> Round Rock

<b>San Antonio Region</b>					
<b>County:</b>	<b>Bexar</b>	<b>Comal</b>	<b>Kinney</b>	<b>Medina</b>	<b>Uvalde</b>
Original (1 req.)	—	X	—	—	—
Region (1 req.)	—	X	—	—	—
County(ies)	—	X	—	—	—
Groundwater Conservation District(s)	<input type="checkbox"/> Edwards Aquifer Authority <input type="checkbox"/> Trinity-Glen Rose	<input type="checkbox"/> Edwards Aquifer Authority	<input type="checkbox"/> Kinney	<input type="checkbox"/> EAA Medina	<input type="checkbox"/> EAA Uvalde
City(ies) Jurisdiction	<input type="checkbox"/> Castle Hills <input type="checkbox"/> Fair Oaks Ranch <input type="checkbox"/> Helotes <input type="checkbox"/> Hill Country Village <input type="checkbox"/> Hollywood Park <input type="checkbox"/> San Antonio (SAWS) <input type="checkbox"/> Shavano Park	<input type="checkbox"/> Bulverde <input type="checkbox"/> Fair Oaks Ranch <input type="checkbox"/> Garden Ridge <input checked="" type="checkbox"/> New Braunfels <input type="checkbox"/> Schertz	NA	<input type="checkbox"/> San Antonio ETJ (SAWS)	NA

I certify that to the best of my knowledge, that the application is complete and accurate. This application is hereby submitted to TCEQ for administrative review and technical review.

Priscilla G. Flores, PE.

Print Name of Customer/Authorized Agent

*Priscilla G. Flores*

*3/7/24*

Signature of Customer/Authorized Agent

Date

**FOR TCEQ INTERNAL USE ONLY**			
Date(s) Reviewed:		Date Administratively Complete:	
Received From:		Correct Number of Copies:	
Received By:		Distribution Date:	
EAPP File Number:		Complex:	
Admin. Review(s) (No.):		No. AR Rounds:	
Delinquent Fees (Y/N):		Review Time Spent:	
Lat./Long. Verified:		SOS Customer Verification:	
Agent Authorization Complete/Notarized (Y/N):		Fee Check:	Payable to TCEQ (Y/N):
Core Data Form Complete (Y/N):			Signed (Y/N):
Core Data Form Incomplete Nos.:			Less than 90 days old (Y/N):

# General Information Form

Texas Commission on Environmental Quality

For Regulated Activities on the Edwards Aquifer Recharge and Transition Zones and Relating to 30 TAC §213.4(b) & §213.5(b)(2)(A), (B) Effective June 1, 1999

*To ensure that the application is administratively complete, confirm that all fields in the form are complete, verify that all requested information is provided, consistently reference the same site and contact person in all forms in the application, and ensure forms are signed by the appropriate party.*

*Note: Including all the information requested in the form and attachments contributes to more streamlined technical reviews.*

## Signature

To the best of my knowledge, the responses to this form accurately reflect all information requested concerning the proposed regulated activities and methods to protect the Edwards Aquifer. This **General Information Form** is hereby submitted for TCEQ review. The application was prepared by:

Print Name of Customer/Agent: Priscilla G. Flores, PE

Date: 3-7-2024

Signature of Customer/Agent:

Priscilla G Flores

## Project Information

1. Regulated Entity Name: Veramendi Precints 18-2 & 19-1
2. County: Comal
3. Stream Basin: Blieders Creek
4. Groundwater Conservation District (If applicable): \_\_\_\_\_
5. Edwards Aquifer Zone:
  - Recharge Zone
  - Transition Zone
6. Plan Type:
  - WPAP
  - SCS
  - Modification
  - AST
  - UST
  - Exception Request

7. Customer (Applicant):

Contact Person: Garrett Mechler  
Entity: Veramendi PE-Emerald LLC  
Mailing Address: 387 W Mill St, Ste 108  
City, State: New Braunfels, TX Zip: 78130  
Telephone: 830-660-4755 FAX: \_\_\_\_\_  
Email Address: garrett.mechler@asaproperties.us.com

8. Agent/Representative (If any):

Contact Person: Priscilla G. Flores, PE.  
Entity: LJA Engineering, LLC  
Mailing Address: 9830 Colonnade Blvd Ste 300  
City, State: San Antonio, TX Zip: 78256  
Telephone: 210-503-2700 FAX: \_\_\_\_\_  
Email Address: pflores@lja.com

9. Project Location:

- The project site is located inside the city limits of \_\_\_\_\_.
- The project site is located outside the city limits but inside the ETJ (extra-territorial jurisdiction) of New Braunfels
- The project site is not located within any city's limits or ETJ.

10.  The location of the project site is described below. The description provides sufficient detail and clarity so that the TCEQ's Regional staff can easily locate the project and site boundaries for a field investigation.

3600 LF north of the intersection between Loop 337 and River Rd

11.  **Attachment A – Road Map.** A road map showing directions to and the location of the project site is attached. The project location and site boundaries are clearly shown on the map.

12.  **Attachment B - USGS / Edwards Recharge Zone Map.** A copy of the official 7 ½ minute USGS Quadrangle Map (Scale: 1" = 2000') of the Edwards Recharge Zone is attached. The map(s) clearly show:

- Project site boundaries.
- USGS Quadrangle Name(s).
- Boundaries of the Recharge Zone (and Transition Zone, if applicable).
- Drainage path from the project site to the boundary of the Recharge Zone.

13.  **The TCEQ must be able to inspect the project site or the application will be returned.** Sufficient survey staking is provided on the project to allow TCEQ regional staff to locate the boundaries and alignment of the regulated activities and the geologic or manmade features noted in the Geologic Assessment.

Survey staking will be completed by this date: \_\_\_\_\_

14.  **Attachment C – Project Description.** Attached at the end of this form is a detailed narrative description of the proposed project. The project description is consistent throughout the application and contains, at a minimum, the following details:

- Area of the site
- Offsite areas
- Impervious cover
- Permanent BMP(s)
- Proposed site use
- Site history
- Previous development

N/A  Area(s) to be demolished

15. Existing project site conditions are noted below:

- Existing commercial site
- Existing industrial site
- Existing residential site
- Existing paved and/or unpaved roads
- Undeveloped (Cleared)
- Undeveloped (Undisturbed/Uncleared)
- Other: \_\_\_\_\_

### ***Prohibited Activities***

16.  I am aware that the following activities are prohibited on the Recharge Zone and are not proposed for this project:

- (1) Waste disposal wells regulated under 30 TAC Chapter 331 of this title (relating to Underground Injection Control);
- (2) New feedlot/concentrated animal feeding operations, as defined in 30 TAC §213.3;
- (3) Land disposal of Class I wastes, as defined in 30 TAC §335.1;
- (4) The use of sewage holding tanks as parts of organized collection systems; and
- (5) New municipal solid waste landfill facilities required to meet and comply with Type I standards which are defined in §330.41(b), (c), and (d) of this title (relating to Types of Municipal Solid Waste Facilities).
- (6) New municipal and industrial wastewater discharges into or adjacent to water in the state that would create additional pollutant loading.

17.  I am aware that the following activities are prohibited on the Transition Zone and are not proposed for this project:

- (1) Waste disposal wells regulated under 30 TAC Chapter 331 (relating to Underground Injection Control);
- (2) Land disposal of Class I wastes, as defined in 30 TAC §335.1; and



- (3) New municipal solid waste landfill facilities required to meet and comply with Type I standards which are defined in §330.41 (b), (c), and (d) of this title.

### ***Administrative Information***

18. The fee for the plan(s) is based on:

- For a Water Pollution Abatement Plan or Modification, the total acreage of the site where regulated activities will occur.
  - For an Organized Sewage Collection System Plan or Modification, the total linear footage of all collection system lines.
  - For a UST Facility Plan or Modification or an AST Facility Plan or Modification, the total number of tanks or piping systems.
  - A request for an exception to any substantive portion of the regulations related to the protection of water quality.
  - A request for an extension to a previously approved plan.
19.  Application fees are due and payable at the time the application is filed. If the correct fee is not submitted, the TCEQ is not required to consider the application until the correct fee is submitted. Both the fee and the Edwards Aquifer Fee Form have been sent to the Commission's:
- TCEQ cashier
  - Austin Regional Office (for projects in Hays, Travis, and Williamson Counties)
  - San Antonio Regional Office (for projects in Bexar, Comal, Kinney, Medina, and Uvalde Counties)
20.  Submit one (1) original and one (1) copy of the application, plus additional copies as needed for each affected incorporated city, groundwater conservation district, and county in which the project will be located. The TCEQ will distribute the additional copies to these jurisdictions. The copies must be submitted to the appropriate regional office.
21.  No person shall commence any regulated activity until the Edwards Aquifer Protection Plan(s) for the activity has been filed with and approved by the Executive Director.

# VERAMENDI PRECINCT 18 UNIT-2 & PRECINCT 19 UNIT-1

CITY OF NEW BRAUNFELS ETJ

LOCATION EXHIBIT

NOVEMBER 2023

## LEGEND

 PROJECT BOUNDARY

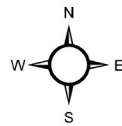

0 500 1,000 2,000  
FEET

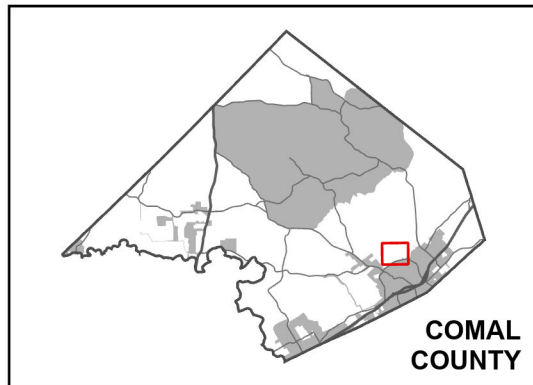

AERIAL PHOTOGRAPH: 2023 NEARMAP

THIS PRODUCT IS FOR INFORMATIONAL PURPOSES AND MAY NOT HAVE BEEN PREPARED FOR OR BE SUITABLE FOR LEGAL, ENGINEERING, OR SURVEYING PURPOSES. IT DOES NOT REPRESENT AN ON-THE-GROUND SURVEY AND REPRESENTS ONLY THE APPROXIMATE RELATIVE LOCATION OF PROPERTY BOUNDARIES.









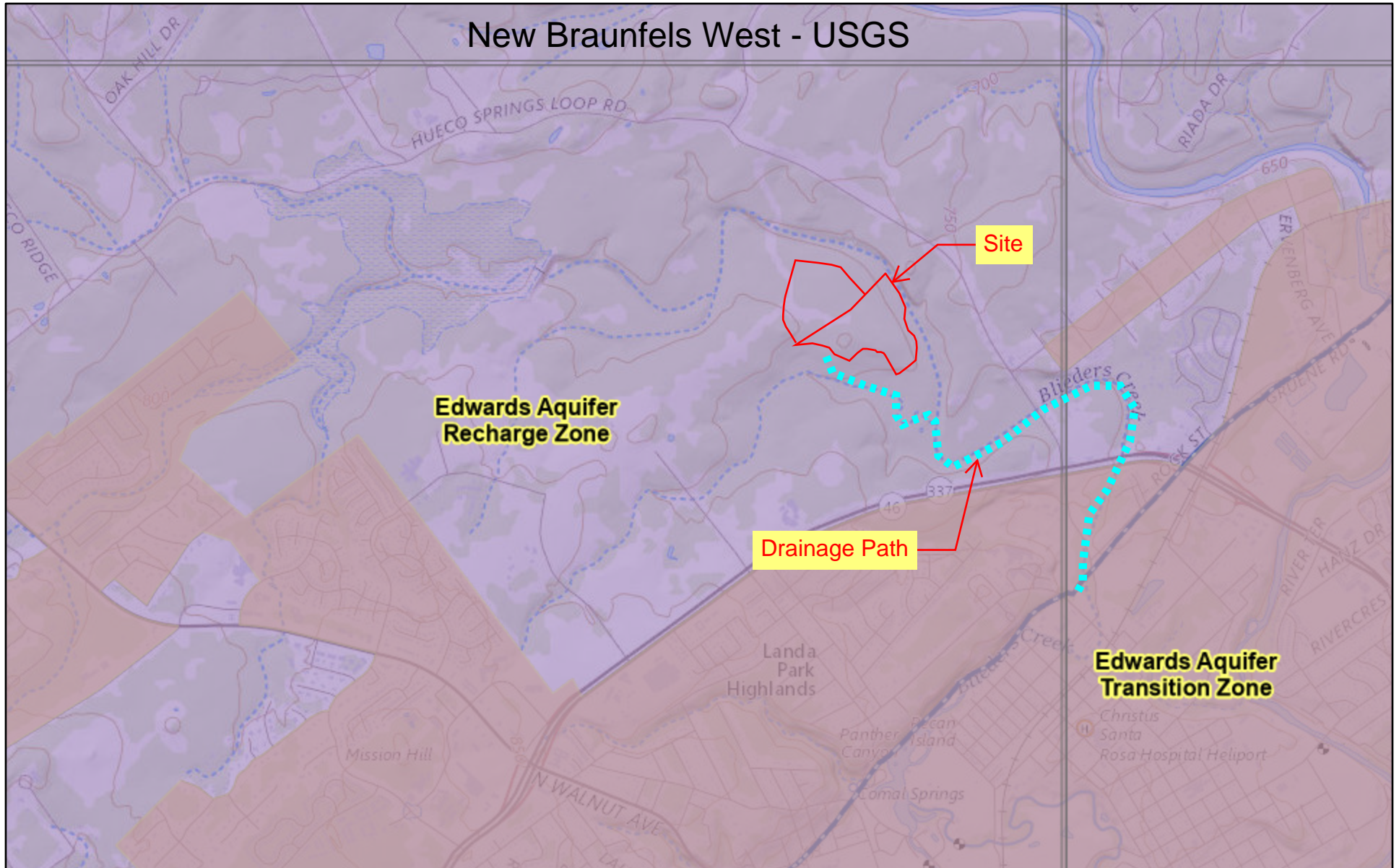



9830 Colonnade Boulevard, Suite 300  
San Antonio, Texas 78230  
Phone 210.503.2700  
LJA.com



# Edwards Aquifer Viewer Custom Print



11/27/2023, 11:04:14 AM

- |  |  |  |
|--|--|--|
|  Edwards Aquifer Label                 |  City/Place                         |  TX Counties                |
|  Edwards Aquifer Boundary              |  Groundwater Conservation Districts |  7.5 Minute Quad Grid       |
|  Edwards Aquifer Boundary central line |  Comal Trinity GCD                  |  TCEQ_EDWARDS_OFFICIAL_MAPS |
|  |  Edwards Aquifer Authority          |  |

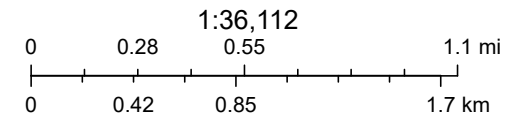

TCEQ, USGS The National Map: National Boundaries Dataset, 3DEP Elevation Program, Geographic Names Information System, National

Web AppBuilder for ArcGIS

### **Attachment C – Project Narrative**

The proposed site is located 3600 LF North of the intersection between Loop 337 and River Rd in New Braunfels, Texas. Proposed use for the development will be a Residential (single family). The site is in the New Braunfels ETJ. The Veramendi Precincts 18-2 & 19-1 WPAP will consist of a 80.45-acre tract for single family houses, 33.66 acres will be under impervious cover (41.8%). We are treating with the proposed extended detention water quality pond a total of 15.97 acres of the total impervious cover. Also with the vegetated filter strips we are treating a total of 12.05 of impervious cover. The site doesn't receive offsite drainage area. We are proposing 9,625.62 LF of a Sewage Collection System. The proposed improvements addressed by this Water Pollution Abatement Plan (WPAP) and SCS Plan are:

A portion of the site will drain towards an existing Water Quality Pond, located south of our site. The existing water quality ponds have enough treatment capacity for the proposed development (please refer to attached approved WPAP). The total impervious cover draining from our site towards the existing Water Quality Pond is 5.65 ac.

- (1) 3 Proposed Water Quality Extended Detention Ponds
- (2) Existing Water Quality Ponds
- (3) Vegetated Filter Strips
- (4) 9,625.62 LF of a proposed Sewage Collection System/

The Permanent Pollution Abatement Measures (BMPs) for Veramendi Precinct 18-2 & 19-1 development will consists of one (3) Water Quality Extended Detention Ponds basin designed in accordance with the TCEQ Technical Guidance Manual to remove 89% of the increased Total Suspended Solids (TSS) for the proposed improvements.

Potable water and wastewater disposal are provided New Braunfels Wastewater Treatment Plan. Wastewater is disposed of by conveyance to the existing treatment center operated by New Braunfels Wastewater Treatment Plan.

***Geologic Site Assessment (SCS)  
for Regulated Activities / Development  
on the Edwards Aquifer Recharge / Transition Zone***

**Veramendi Subdivision  
Units 18-2 & 19-1  
+/- 80 Acres  
New Braunfels, Texas**

***FROST GEOSCIENCES CONTROL # FGS-E23192***

***February 15, 2024***

---

***Prepared exclusively for***

***ASA Properties  
PO Box 310699  
New Braunfels, Texas 78131***

***Frost GeoSciences***

***Geotechnical ▪ Construction Materials  
Forensics ▪ Environmental***

***13406 Western Oak Helotes, Texas 78023 Phone: (210) 372-1315 Fax: (210) 372-1318***

# Frost GeoSciences

Geotechnical • Construction Materials  
Forensics • Environmental

13406 Western Oak

Helotes, Texas 78023

Phone (210) 372-1315

Fax (210) 372-1318

www.frostgeosciences.com

TBPE Firm Registration # F-9227

TBPG Firm Registration # 50040

February 15, 2024

ASA Properties  
PO Box 310699  
New Braunfels, Texas 78131

Attn: Mr. Garrett Mechler, P.E.

Re: Geologic Site Assessment (SCS)  
for Regulated Activities / Development on the  
Edwards Aquifer Recharge / Transition Zone  
Veramendi Subdivision, Units 18-2 & 19-1  
+/- 80 Acres  
New Braunfels, Texas

Frost GeoSciences, Inc. Control # FGS-E23192

Dear Sir:

Attached is a copy of the Geologic Assessment Report completed for the above referenced project site as it relates to 30 TAC §213.5(b)(3), effective June 1, 1999. Our investigation was conducted and this report was prepared in general accordance with the "Instructions to Geologists", TCEQ-0585-Instructions (Rev. 10-1-04). The results of our investigation, along with any recommendations for Best Management Practices (BMP's), are provided in the following report.

If you have any questions regarding this report, or if Frost GeoSciences, Inc. may be of additional assistance to you on this project, please feel free to call our office. It has been a pleasure to work with you and we wish to thank you for the opportunity to be of service to you on this project. We look forward to being of continued service.



Sincerely,  
Frost GeoSciences, Inc.

A handwritten signature in black ink that reads "Steve Frost".

Steve Frost, C.P.G., P.G.  
President, Principal Geologist

Distribution: (6) ASA Properties

**Table of Contents**

GEOLOGIC ASSESSMENT FORM ..... 1

STRATIGRAPHIC COLUMN ..... 4

GEOLOGIC ASSESSMENT TABLE ..... 5

LOCATION ..... 6

METHODOLOGY ..... 6

RESEARCH & OBSERVATIONS ..... 7

    7.5 Minute Quadrangle Map Review ..... 7

    Recharge/Transition Zone ..... 7

    100-Year Floodplain ..... 7

    Soils ..... 8

    Narrative Description of the Site Geology ..... 9

BEST MANAGEMENT PRACTICES ..... 11

DISCLAIMER ..... 12

REFERENCES ..... 12

APPENDIX

A:    Plate 1:    Site Plan

        Plate 2:    Street Map

        Plate 3:    USGS Topographic Map

        Plate 4:    Official Edwards Aquifer Recharge Zone Map

        Plate 5:    FEMA Flood Map

        Plate 6:    1973 Aerial Photograph, 1"=1000'

        Plate 7:    Geologic Map

        Plate 8:    2023 Aerial Photograph, 1"=500'

        Plate 9:    2023 Aerial Photograph with PRF's, 1"=500'

B:    Site Photographs

C:    Site Geologic Map

# Geologic Assessment

## Texas Commission on Environmental Quality

For Regulated Activities on The Edwards Aquifer Recharge/transition Zones and Relating to 30 TAC §213.5(b)(3), Effective June 1, 1999

**To ensure that the application is administratively complete, confirm that all fields in the form are complete, verify that all requested information is provided, consistently reference the same site and contact person in all forms in the application, and ensure forms are signed by the appropriate party.**

**Note: Including all the information requested in the form and attachments contributes to more streamlined technical reviews.**

## Signature

To the best of my knowledge, the responses to this form accurately reflect all information requested concerning the proposed regulated activities and methods to protect the Edwards Aquifer. My signature certifies that I am qualified as a geologist as defined by 30 TAC Chapter 213.

Print Name of Geologist: Steve Frost, C.P.G., P.G. Telephone: (210) 372-1315

Date: February 15, 2024 Fax: (210) 372-1318

Representing: Frost GeoSciences, Inc.

Signature of Geologist:

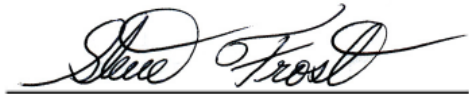

Regulated Entity Name: Veramendi Subdivision, Units 18-2 & 19-1

## Project Information

1. Date(s) Geologic Assessment was performed: December 7, 2023

2. Type of Project:

- |   |                              |
|---|------------------------------|
| <input type="checkbox"/> WPAP           | <input type="checkbox"/> AST |
| <input checked="" type="checkbox"/> SCS | <input type="checkbox"/> UST |

3. Location of Project:

- |   |
|---|
| <input checked="" type="checkbox"/> Recharge Zone                     |
| <input type="checkbox"/> Transition Zone                              |
| <input type="checkbox"/> Contributing Zone within the Transition Zone |



- 4.  **Attachment A - Geologic Assessment Table.** Completed Geologic Assessment Table (Form TCEQ-0585-Table) is attached.
- 5.  Soil cover on the project site is summarized in the table below and uses the SCS Hydrologic Soil Groups\* (Urban Hydrology for Small Watersheds, Technical Release No. 55, Appendix A, Soil Conservation Service, 1986). If there is more than one soil type on the project site, show each soil type on the site Geologic Map or a separate soils map.

**Table 1 - Soil Units, Infiltration Characteristics and Thickness**

Soil Name	Group*	Thickness(feet)
RuD	C/D	1 to 2
CrD	D/D	0 to 2

- \* Soil Group Definitions (Abbreviated)*
- A. Soils having a high infiltration rate when thoroughly wetted.
  - B. Soils having a moderate infiltration rate when thoroughly wetted.
  - C. Soils having a slow infiltration rate when thoroughly wetted.
  - D. Soils having a very slow infiltration rate when thoroughly wetted.

- 6.  **Attachment B – Stratigraphic Column.** A stratigraphic column showing formations, members, and thicknesses is attached. The outcropping unit, if present, should be at the top of the stratigraphic column. Otherwise, the uppermost unit should be at the top of the stratigraphic column.
- 7.  **Attachment C – Site Geology.** A narrative description of the site specific geology including any features identified in the Geologic Assessment Table, a discussion of the potential for fluid movement to the Edwards Aquifer, stratigraphy, structure(s), and karst characteristics is attached.
- 8.  **Attachment D – Site Geologic Map(s).** The Site Geologic Map must be the same scale as the applicant's Site Plan. The minimum scale is 1": 400'  
 Applicant's Site Plan Scale: 1" = 200 '  
 Site Geologic Map Scale: 1" = 200 '  
 Site Soils Map Scale (if more than 1 soil type): 1" = 1000 '
- 9. Method of collecting positional data:
  - Global Positioning System (GPS) technology.
  - Other method(s). Please describe method of data collection: 2023 Aerial Photograph
- 10.  The project site and boundaries are clearly shown and labeled on the Site Geologic Map.
- 11.  Surface geologic units are shown and labeled on the Site Geologic Map.

12.  Geologic or manmade features were discovered on the project site during the field investigation. They are shown and labeled on the Site Geologic Map and are described in the attached Geologic Assessment Table.
- Geologic or manmade features were not discovered on the project site during the field investigation.
13.  The Recharge Zone boundary is shown and labeled, if appropriate.
14. All known wells (test holes, water, oil, unplugged, capped and/or abandoned, etc.): If applicable, the information must agree with Item No. 20 of the WPAP Application Section.
- There are \_\_\_\_\_ (#) wells present on the project site and the locations are shown and labeled. (Check all of the following that apply.)
- The wells are not in use and have been properly abandoned.
- The wells are not in use and will be properly abandoned.
- The wells are in use and comply with 16 TAC Chapter 76.
- There are no wells or test holes of any kind known to exist on the project site.

### ***Administrative Information***

15.  Submit one (1) original and one (1) copy of the application, plus additional copies as needed for each affected incorporated city, groundwater conservation district, and county in which the project will be located. The TCEQ will distribute the additional copies to these jurisdictions. The copies must be submitted to the appropriate regional office.

## Stratigraphic Column

[Hydrogeologic subdivisions modified from Maclay and Small (1976); groups, formations, and members modified from Rose (1972); lithology modified from Dunham (1962); and porosity type modified from Choquette and Pray (1970). CU, confining unit; AQ, aquifer]

Hydrogeologic subdivision		Group, formation, or member	Hydro-logic function	Thickness (feet)	Lithology	Field identification	Cavern development	Porosity/permeability type	
Upper Cretaceous	Upper confining units	Eagle Ford Group	CU	30 – 50	Brown, flaggy shale and argillaceous limestone	Thin flagstones; petroliferous	None	Primary porosity lost/ low permeability	
		Buda Limestone	CU	40 – 50	Buff, light gray, dense mudstone	Porcelaneous limestone with calcite-filled veins	Minor surface karst	Low porosity/low permeability	
		Del Rio Clay	CU	40 – 50	Blue-green to yellow-brown clay	Fossiliferous; <i>Ilymatogyra arietina</i>	None	None/primary upper confining unit	
Lower Cretaceous	Edwards Group	Edwards Group	Georgetown Formation	Karst AQ; not karst CU	2 – 20	Reddish-brown, gray to light tan marly limestone	Marker fossil; <i>Waconella wacoensis</i>	None	Low porosity/low permeability
			Kainer Formation	Cyclic and marine members, undivided	AQ	80 – 90	Mudstone to packstone; <i>miliolid</i> grainstone; chert	Thin graded cycles; massive beds to relatively thin beds; crossbeds	Many subsurface; might be associated with earlier karst development
		Leached and collapsed members, undivided		AQ	70 – 90	Crystalline limestone; mudstone to grainstone; chert; collapsed breccia	Bioturbated iron-stained beds separated by massive limestone beds; stromatolitic limestone	Extensive lateral development; large rooms	Majority not fabric/one of the most permeable
		Regional dense member		CU	20 – 24	Dense, argillaceous mudstone	Wispy iron-oxide stains	Very few; only vertical fracture enlargement	Not fabric/low permeability; vertical barrier
		Grainstone member		AQ	50 – 60	<i>Miliolid</i> grainstone; mudstone to wackestone; chert	White crossbedded grainstone	Few	Not fabric/ recrystallization reduces permeability
		Kirschberg evaporite member		AQ	50 – 60	Highly altered crystalline limestone; chalky mudstone; chert	Boxwork voids, with neospar and travertine frame	Probably extensive cave development	Majority fabric/one of the most permeable
		Dolomitic member		AQ	110 – 130	Mudstone to grainstone; crystalline limestone; chert	Massively bedded light gray, <i>Toucasia</i> abundant	Caves related to structure or bedding planes	Mostly not fabric; some bedding plane-fabric/water-yielding
		Basal nodular member		Karst AQ; not karst CU	50 – 60	Shaly, nodular limestone; mudstone and <i>miliolid</i> grainstone	Massive, nodular and mottled, <i>Exogyra texana</i>	Large lateral caves at surface; a few caves near Cibolo Creek	Fabric; stratigraphically controlled/large conduit flow at surface; no permeability in subsurface
		Lower confining unit	Upper member of the Glen Rose Limestone	CU; evaporite beds AQ	350 – 500	Yellowish tan, thinly bedded limestone and marl	Stair-step topography; alternating limestone and marl	Some surface cave development	Some water production at evaporite beds/relatively impermeable



## LOCATION

The project site consists of approximately 80 Acres of land within the existing Veramendi Subdivision, located north of Loop 337 and south of River Road in New Braunfels, Texas. An overall view of the area is shown on copies of the site plan, a street map, the USGS Topographic Map, the Edwards Aquifer Recharge Zone Map, the Flood Insurance Rate Map (FIRM), a 1973 aerial photograph from the USDA at a scale of 1"=1000', a geologic map, a 2023 aerial photograph at a scale of 1"=500', and a 2023 aerial photograph with potential recharge features at a scale of 1"=500', Plates 1 through 9 in Appendix A.

## METHODOLOGY

The Geologic Assessment was performed by Mr. Steve Frost, C.P.G., President and Principal Geologist with Frost GeoSciences, Inc. Mr. Frost is a Licensed Professional Geoscientist in the State of Texas (License # 315) and is a Certified Professional Geologist with the American Institute of Professional Geologist (Certification # 10176).

Frost GeoSciences, Inc. researched the geology of the area in the immediate vicinity of the project site. The research included, but was not limited to, the Geologic Atlas of Texas, San Antonio Sheet, FIRM maps, Edwards Aquifer Recharge Zone Maps, USGS 7.5 Minute Quadrangle Maps, the Geologic Map of the New Braunfels, Texas 30 X 60 Minute Quadrangle, the USGS Water-Resources Investigations Report 94-4117, and the USDA Soil Survey of Comal & Hays County, Texas.

After reviewing the available information, a field investigation was performed to identify any geologic or man-made potential recharge features. A transect spacing of approximately 50 feet or less, depending on vegetation thickness, was used to inspect the project site within a 50 foot boundary of the proposed sewer lines. A 2023 aerial photograph, in conjunction with a hand held Global Positioning System with an Estimated Potential Error ranging from 7 to 10 feet, was used to navigate around the property and identify the locations of potential recharge features, as recommended in the "Instructions to Geologists", TCEQ-0585-Instructions (Rev. 10-1-04). The

locations of any potential recharge features noted in the field were identified on the Site Geologic Map in Appendix C of this report. A copy of a 2023 aerial photograph at an approximate scale of 1"=100M, indicating the locations of the potential recharge features, is included on Plate 9 in Appendix A. The Geologic Assessment Form (Rev. 2-11-15), Stratigraphic Column, and the Geologic Assessment Table have been filled with the appropriate information for this project site and are included on pages 1-5 of this report.

## **RESEARCH & OBSERVATIONS**

### **7.5 Minute Quadrangle Map Review**

According to the USGS 7.5 Minute Quadrangle Map, New Braunfels West, Texas Sheet (1988), the elevation of the project site ranges from 680 feet at the eastern and southern limits of the project site near Blieders Creek to 750 feet in the south central portion of the project site. These elevations are calculated above mean sea level (AMSL). The surface runoff from the project site flows into unnamed tributaries of Blieders Creek, and Blieders Creek. State Highway 46 (Loop 337) is located south of the project site. River Road is located north of the project site. A copy of the above referenced USGS 7.5 Minute Quadrangle Map, indicating the location of the project site, is included in this report on Plate 3 in Appendix A.

### **Recharge / Transition Zone**

According to Official Edwards Aquifer Recharge Zone Map, New Braunfels West, Texas Sheet, 2014, the project site is located within the Recharge Zone of the Edwards Aquifer. A copy of the Official Edwards Aquifer Recharge Zone Map, indicating the location of the project site, is included on Plate 4 in Appendix A.

### **100-Year Floodplain**

The Federal Emergency Management Agency (FEMA) Flood Insurance Rate Map for Comal County, Texas, Community Panel Number 48091C0435F, (Revised 9/02/09) was reviewed

*February 15, 2024*  
**Veramendi Subdivision, Units 18-2 & 19-1**  
*page 7*

to determine if the project site is located in areas prone to flooding. A review of the above-mentioned panel indicates that portions of the project site is located within the 100 year floodplain. The project site is located within Zone AE, Zone A, Zone X Shaded, and Zone X.

Zone AE represents areas determined to be within the 100 year floodplain where base flood elevations have been determined.

Zone A represents areas determined to be within the 100 year floodplain where base flood elevations have not been determined.

Zone X shaded represents areas of 0.2% annual chance of flooding, areas of 1% annual chance of flooding with average depths of less than 1 foot or with drainage areas less than 1 square mile, and areas protected by levees from 1% annual chance of flooding. The areas of the property with Zone X Shaded are generally narrow bands located immediately adjacent to areas determined to be within Zone AE.

Zone X represents areas determined to be outside the 0.2% annual chance floodplain. A copy of the Comal County, Texas, FIRM map, indicating the location of the project site is included in this report on Plate 5 in Appendix A.

### **Soils**

According to the United States Department of Agriculture, Soil Conservation Service, Soil Survey of Comal & Hays County, Texas (1982), the project site is located on the Rumble-Comfort Association (RUD), and the Comfort-Rock Outcrop Complex, Undulating (CrD). A copy of the 1973 aerial photograph (approximate scale: 1"=1000') from the USDA Soil Survey of Comal & Hays County, Texas (1982) indicating the location of the project site and the soil types is included on Plate 6 in Appendix A.

The Rumble-Comfort Association (RuD) consists of shallow and moderately deep soils on uplands in the Edwards Plateau Land Resource Area. The surface layer of the Rumble Soil is dark reddish brown very cherty clay loam about 10 inches thick. Rounded chert and limestone cobbles and gravel cover about 20 percent of the surface. The subsoil to a depth of 14 inches is dark

reddish-brown very cherty clay, and to a depth of 28 inches it is dark reddish-brown extremely stony clay. The underlying material is indurated fractured limestone. The Comfort Soil is dark brown, neutral, extremely stony clay about 7 inches thick. The subsoil to a depth of 12 inches is dark reddish-brown, mildly alkaline, extremely stony clay. The underlying material is indurated fractured limestone. The soil is noncalcareous throughout. The soils in this association are well drained. Surface runoff is medium, but varies due to the occurrence of caves, fracture zones, and sinks. Permeability is moderately slow. Water erosion is a moderate hazard.

The Comfort-Rock Outcrop Complex consists of shallow, clayey soils and Rock Outcrop on side slopes and on hilltops and ridgetops on uplands in the Edwards Plateau Land Resource Area. The Comfort Extremely Stony Clay makes up 49 to more than 95 percent of the complex, but on the average it makes up 70 percent. Rock Outcrop and areas of soil less than 4 inches deep make up 5 to 36 percent, but the average is 15 percent. Typically, the surface layer of the Comfort soil is dark brown extremely stony clay about 6 inches thick. Cobbles and stones as much as 4 feet across cover about 45 percent of the surface. The subsoil extends to a depth of 13 inches. It is dark reddish brown extremely stony clay. The underlying material is indurated fractured limestone. The soil is mildly alkaline and noncalcareous throughout. The Comfort Soil is well drained. Surface runoff is slow to medium. Permeability is slow, and the available water capacity is very low. Water erosion is a slight hazard. This soil has a USDA Texture Classification of extremely stony clay, stony clay, very stony clay, and weathered bedrock. The Unified Classification is CH, GC, CL, or SC. The AASHO Classification is A-2-7, and A-7-6. This soil has an average permeability from 0.6 to 0.2 inches/hour.

### **Narrative Description of the Site Geology**

The project site consists of approximately 80 Acres of land within the existing Veramendi Subdivision, located north of Loop 337 and south of River Road in New Braunfels, Texas. An overall view of the area is shown on Plates 1 through 9 in Appendix A. The majority of the project site has a well developed soil layer on the property with minimal rock outcrops. The



variations in the vegetative cover across the project site are visible in the 2023 aerial photographs on Plates 8 and 9 in Appendix A and in the site visit photographs included in Appendix B. Two Potential Recharge Features (PRF's) were identified during our site inspection. None of these are considered sensitive by Frost GeoSciences, Inc. The features are described in the following paragraphs and detailed on the Geologic Assessment Table on page 5.

#### **Faults (F)**

One fault was noted within the limits of the project site, however this fault crosses the proposed sewer lines in three locations. Potential Recharge Feature (PRF) # S-1013, S-1013a, and S-1013b is a fault crossing the central portion of the project site on a bearing of N 45°. There were no obvious visual indications of fractures or displacements associated with this fault location. This feature is not considered to be sensitive by FGS. This feature scores a 35 on the Geologic Assessment Table. Frost GeoSciences, Inc. recommends that once trenching operations commence, the area for 200 feet on either side of the intersection of the proposed sewer line and the fault be inspected by a Professional Geologist to inspect for the potential for karst features that could provide recharge to the aquifer.

#### **Manmade Features in Bedrock (MB)**

Potential Recharge Feature S-90 is a manmade feature in bedrock consisting of an old bulldozer scab. This feature is not considered sensitive by FGS. This feature scores a 35 on the Geologic Assessment Table.

Potential Recharge Feature S-1014 is a manmade feature in bedrock consisting of a sewer manhole cover. This feature is not considered sensitive by FGS. This feature scores a 35 on the Geologic Assessment Table.

According to the USGS 7.5 Minute Quadrangle Map, New Braunfels West, Texas Sheet (1988), the elevation of the project site ranges from 680 feet at the eastern and southern limits of the project site near Blieders Creek to 750 feet in the south central portion of the project site. These elevations are calculated above mean sea level (AMSL). According to topographic data obtained from LJA Engineering, the elevations on the project site range from 684 feet at the

eastern limits of the project site to 752 feet in the central portion of the project site. A copy of the site plan, indicating the boundary of the project site and the elevations, is included on Plate 1 in Appendix A and on the Site Geologic Map in Appendix C of this report.

According to the Geologic Framework and Hydrogeologic Characteristics of the Edwards Aquifer Recharge Zone, Comal County, Texas. U.S. Geological Survey Water Resources Investigations 94-4117 (1994) the project site is located on the Leached and Collapsed Member of the Edwards Person Limestone (Kep).

The Leached and Collapsed Member of the Edwards Person Limestone consists of crystalline limestone, mudstone to grainstone with chert, and collapsed breccia. This member is stromatolitic limestone. The Leached and Collapsed Member is characterized by bioturbated iron stained beds separated by massive limestone beds. This member is typically one of the most permeable and has extensive lateral development with large rooms. Overall thickness ranges from 70 to 90 feet thick.

This geologic map indicates that a fault is located on the project site. This fault is on a bearing of N45°. No obvious visual indications of this fault was noted in the field at the time of the site inspection.

A copy of the Geologic Framework and Hydrogeologic Characteristics of the Edwards Aquifer Recharge Zone, Comal County, Texas. U.S. Geological Survey Water Resources Investigations 94-4117 (1994) indicating the location of the project site, is included on Plate 7 in Appendix A.

#### **BEST MANAGEMENT PRACTICE (BMP)**

**Based on a visual inspection of the ground surface the overall potential for fluid flow from the surface of the project site into the Edwards Aquifer appears to be low.** The potential always exists to encounter subsurface features that lack a surface expression. Frost GeoSciences, Inc. recommends that we be included in the pre-construction meeting to inform construction personnel of the potential to encounter subsurface karst features during excavating activities. Construction personnel should also be informed of the proper

protocol to follow in the event that a solution cavity and/or cave is encountered during the excavation and development of the property, particularly in the areas around the faults.

#### **DISCLAIMER**

This report has been prepared in general accordance with the "Instructions to Geologists", TCEQ-0585-Instructions (Rev. 10-1-04) by a Licensed Texas Professional Geoscientist. All areas of the project site were carefully inspected for features that could contribute to the recharge of the Edwards Aquifer, however, this survey cannot preclude the presence of subsurface karst features that lack surface expression. This report is not intended to be a definitive investigation of all possible geologic or karst features at this site. All conclusions, opinions and recommendations for Best Management Practices (BMP's) in this report are based on information obtained while researching the project and on the site conditions at the time of our field investigation.

This report has been prepared for and may be relied upon by ASA Properties. This report is based on available known records, a visual inspection of the project site and the work generally accepted for a Geologic Assessment TAC §213.5(b)(3), effective June 1, 1999.

#### **REFERENCES**

- 1) USGS 7.5 Minute Quadrangle Maps, New Braunfels West, Texas Sheet (1988).
- 2) Official Edwards Aquifer Recharge Zone Map 31, New Braunfels West, Texas Sheet (2014).
- 3) Stein, W.G. and Ozuna, G.B., 1994, Geologic Framework and Hydrogeologic Characteristics of the Edwards Aquifer Recharge Zone, Comal County, Texas. U.S. Geological Survey Water Resources Investigations 94-4117.
- 4) Collins, Edward, W., 2000, Geologic Map of the New Braunfels, Texas 30 X 60 Minute Quadrangle.
- 5) Federal Emergency Management Agency (FEMA), Bexar County, Texas and Incorporated Areas, Flood Insurance Rate Maps (FIRM), Panel #, 48091C0435F (9/02/09), FEMA, Washington D.C.
- 7) USDA Soil Conservation Service, Soil Survey of Comal & Hays Counties, Texas (1982).
- 8) TCEQ-0585-Instructions (Rev. 10-1-04). "Instructions to Geologists for Geologic Assessments on the Edwards Aquifer Recharge/Transition Zone."

Appendix A  
Site Location Plates

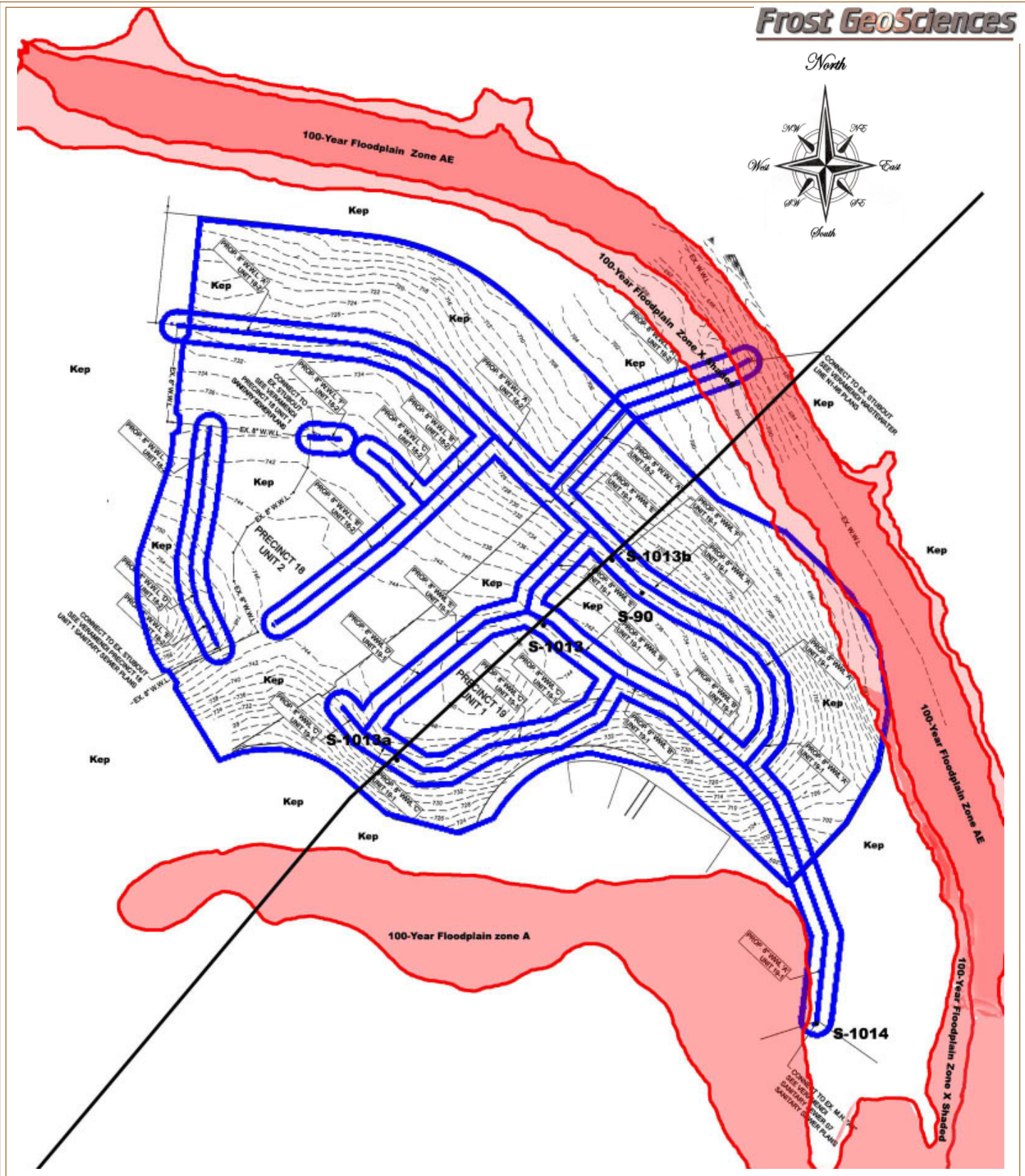

<p><b>PROJECT NAME:</b>                  Geologic Site Assessment (SCS)                  for Regulated Activities / Development on the                  Edwards Aquifer Recharge / Transition Zone                  Veramendi Subdivision, Units 18-2 &amp; 19-1                  New Braunfels, Texas</p>	<p><b>Site Plan</b></p>	
	<p><b>PROJECT NO.:</b>                  FGS-E23192</p>	<p><b>DATE:</b>                  February 15, 2024</p>

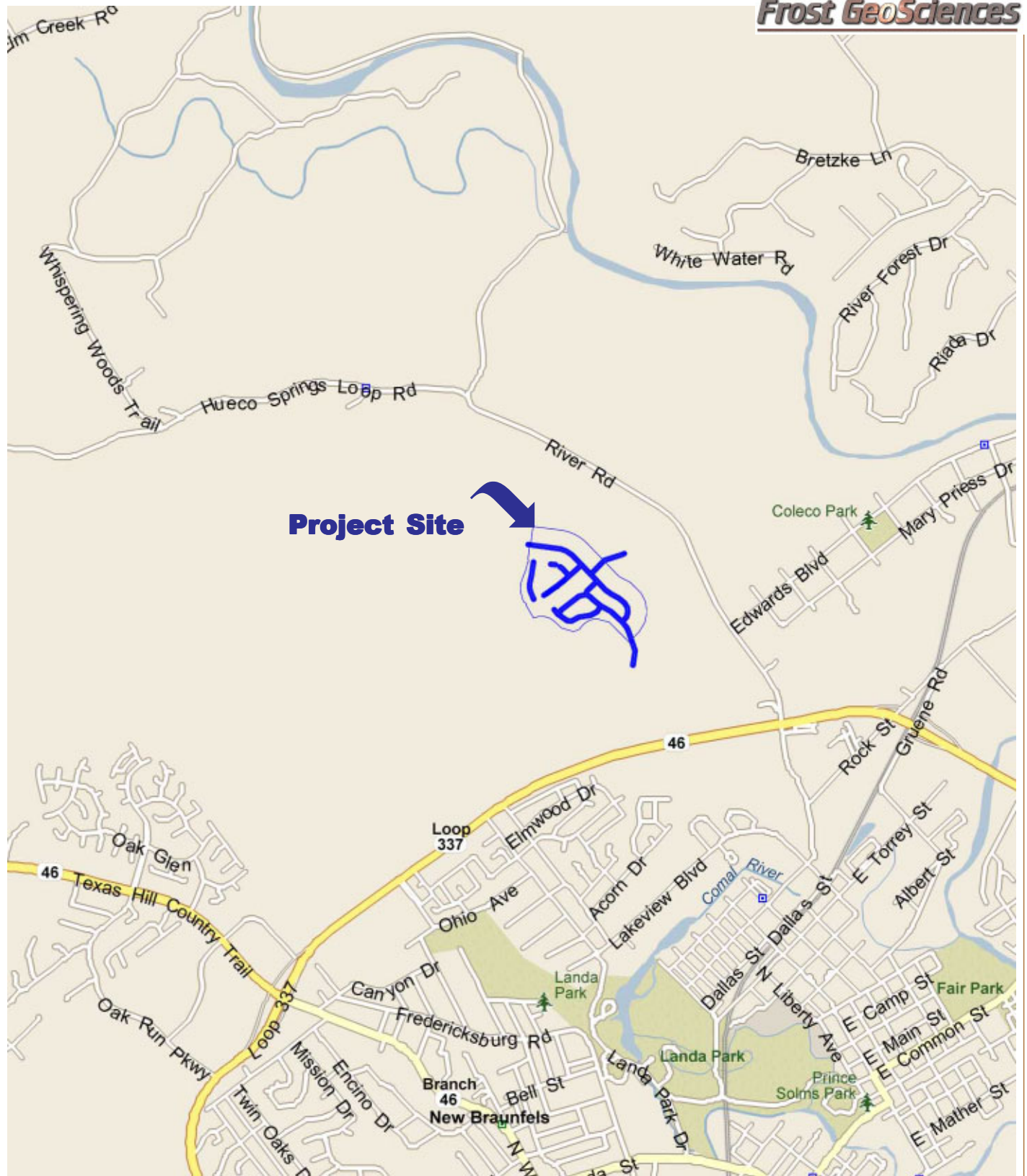

**PROJECT NAME:**

Geologic Site Assessment (SCS)  
for Regulated Activities / Development on the  
Edwards Aquifer Recharge / Transition Zone  
Veramendi Subdivision, Units 18-2 & 19-1  
New Braunfels, Texas

**Street Map**

**PROJECT NO.:**

FGS-E23192

**DATE:**

February 15, 2024

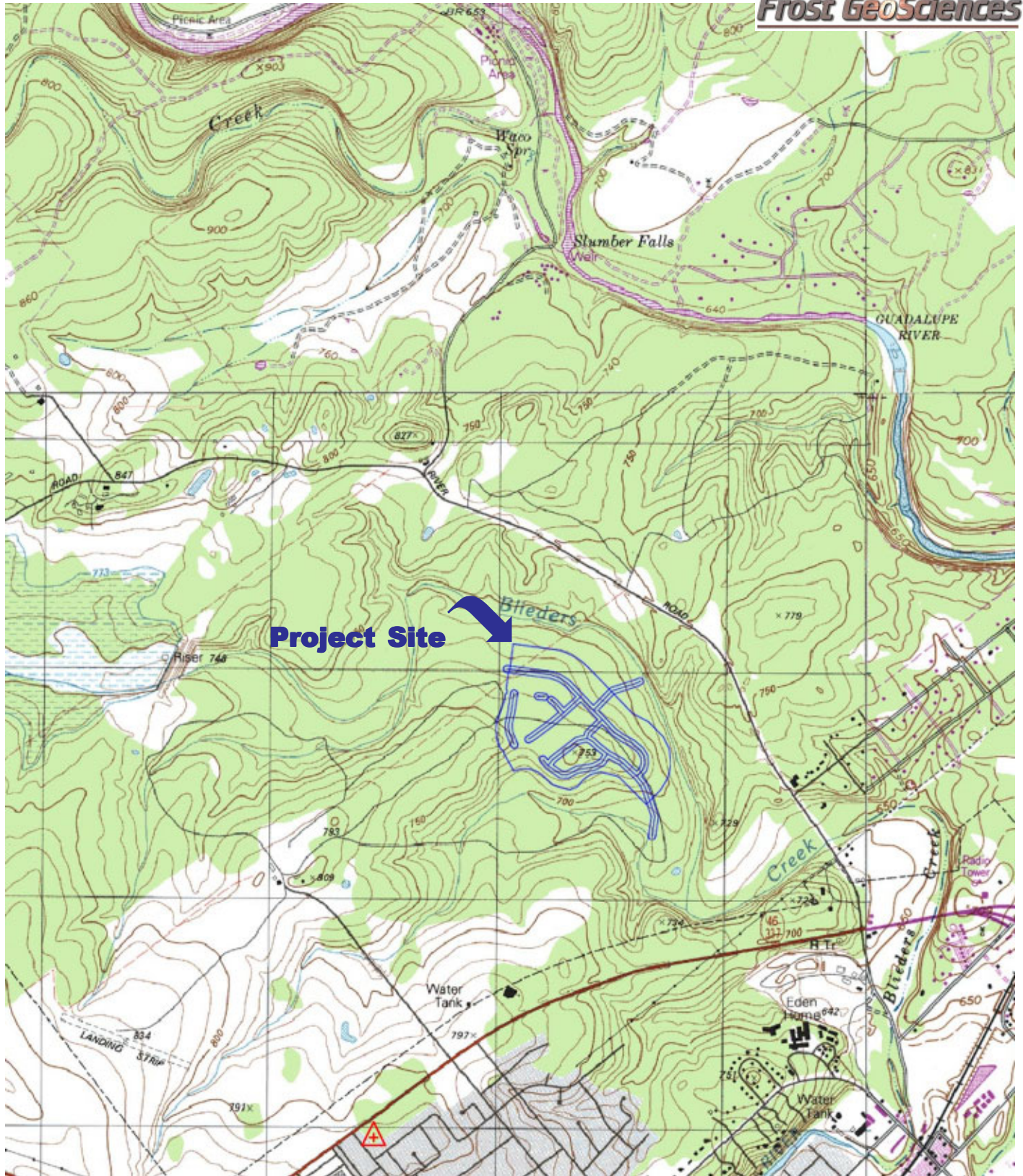

**PROJECT NAME:**

Geologic Site Assessment (SCS)  
for Regulated Activities / Development on the  
Edwards Aquifer Recharge / Transition Zone  
Veramendi Subdivision, Units 18-2 & 19-1  
New Braunfels, Texas

U.S.G.S. 7.5 Minute Quadrangle Map  
New Braunfels West, Texas Sheet (1988)

**PROJECT NO.:**

FGS-E23192

**DATE:**

February 15, 2024

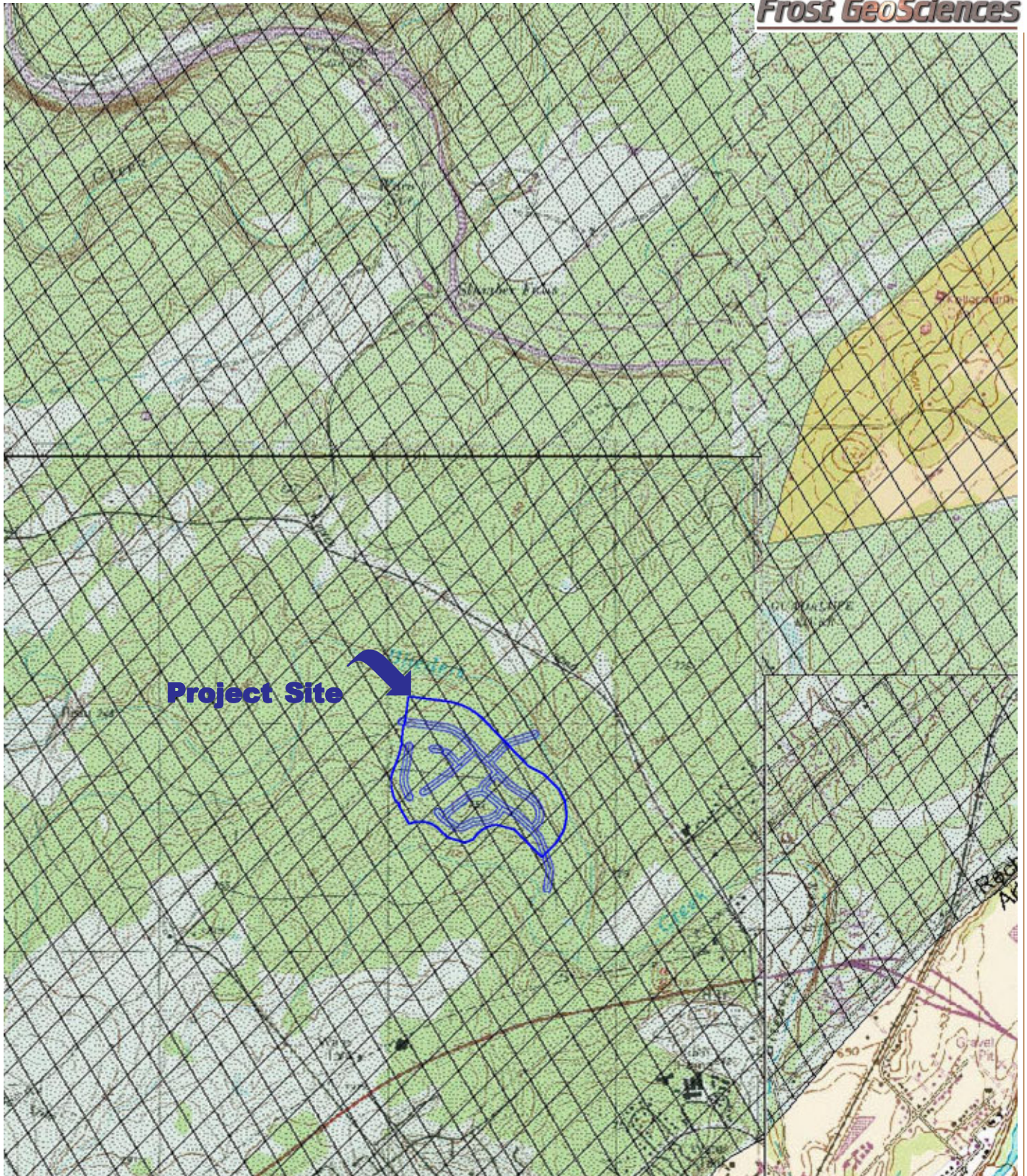

**PROJECT NAME:**

Geologic Site Assessment (SCS)  
for Regulated Activities / Development on the  
Edwards Aquifer Recharge / Transition Zone  
Veramendi Subdivision, Units 18-2 & 19-1  
New Braunfels, Texas

Official Edwards Aquifer Recharge Zone Map  
New Braunfels West, Texas Sheet (2014)

**PROJECT NO.:**

FGS-E23192

**DATE:**

February 15, 2024



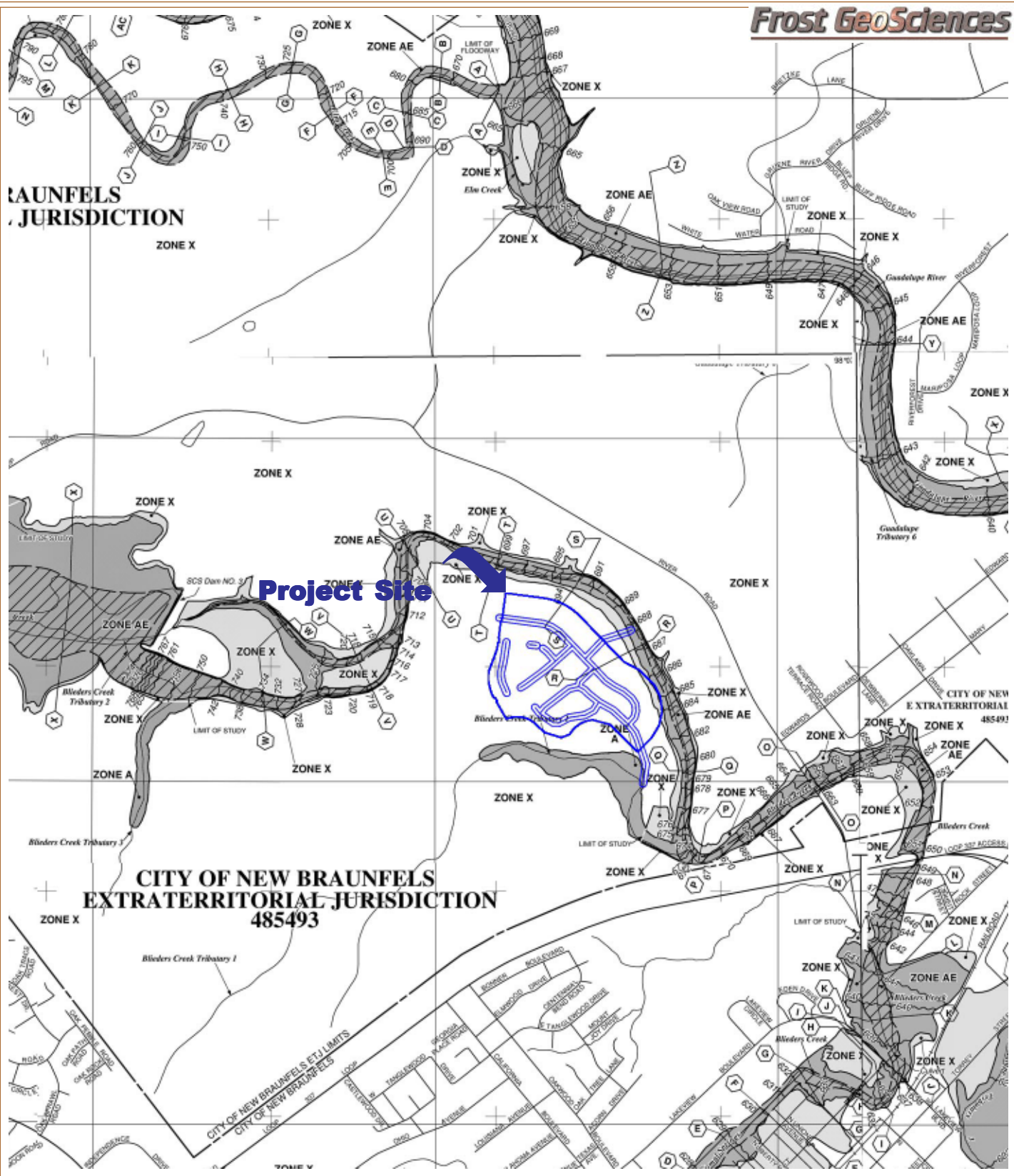

**PROJECT NAME:**

Geologic Site Assessment (SCS)  
for Regulated Activities / Development on the  
Edwards Aquifer Recharge / Transition Zone  
Veramendi Subdivision, Units 18-2 & 19-1  
New Braunfels, Texas

**Flood Insurance Rate Map (FIRM)**  
Community Panel # 48091C0435F  
(Revised 9/02/09)

**PROJECT NO.:**

FGS-E23192

**DATE:**

February 15, 2024



**PROJECT NAME:**

Geologic Site Assessment (SCS)  
for Regulated Activities / Development on the  
Edwards Aquifer Recharge / Transition Zone  
Veramendi Subdivision, Units 18-2 & 19-1  
New Braunfels, Texas

1973 Aerial Photograph  
United States Department of Agriculture

**PROJECT NO.:**

FGS-E23192

**DATE:**

February 15, 2024

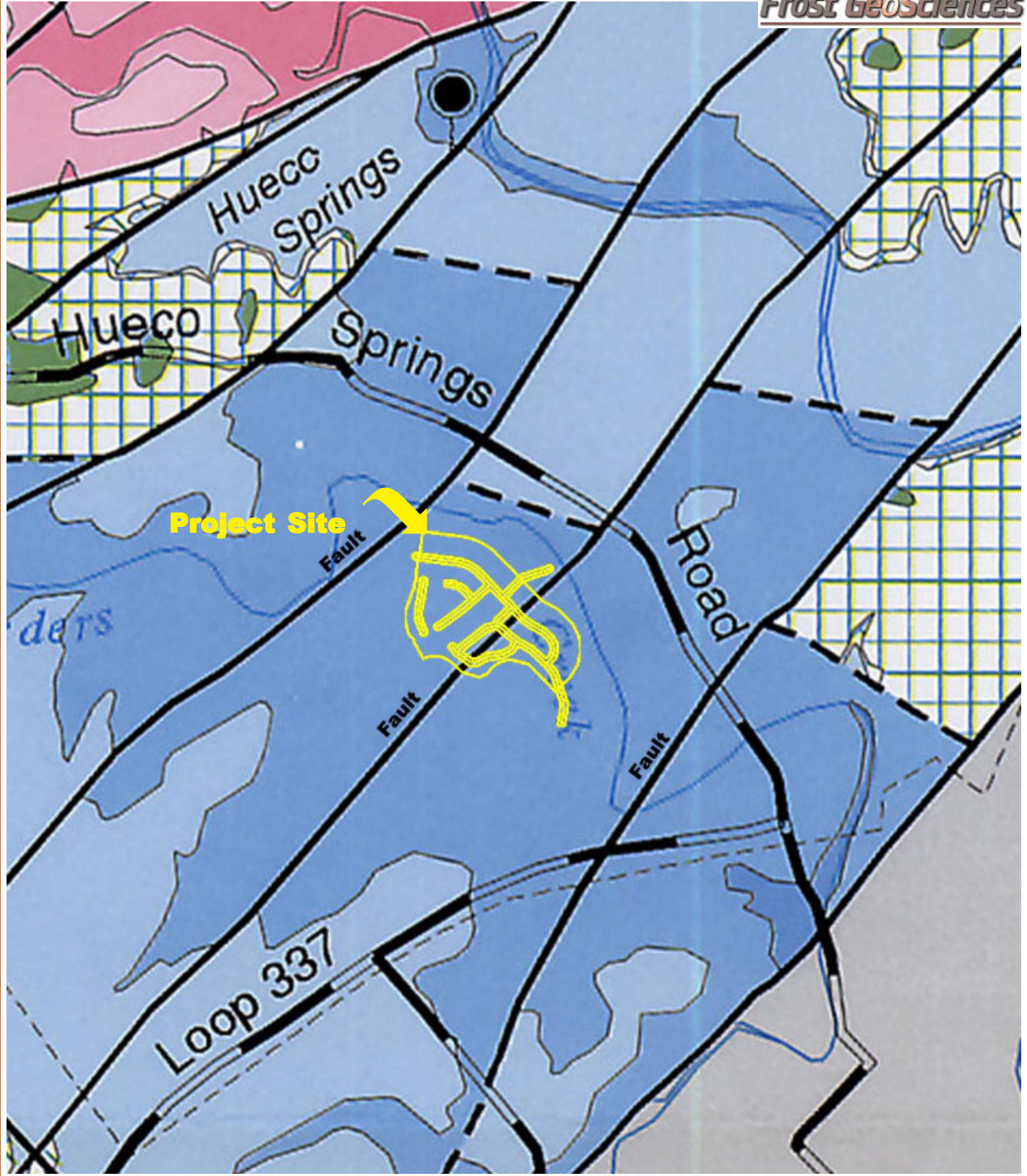

**PROJECT NAME:**  
Geologic Site Assessment (SCS)  
for Regulated Activities / Development on the  
Edwards Aquifer Recharge / Transition Zone  
Veramendi Subdivision, Units 18-2 & 19-1  
New Braunfels, Texas

U.S. Geological Survey Water Resources  
Investigations 94-4117 (1994)

**PROJECT NO.:**  
FGS-E23192

**DATE:**  
February 15, 2024

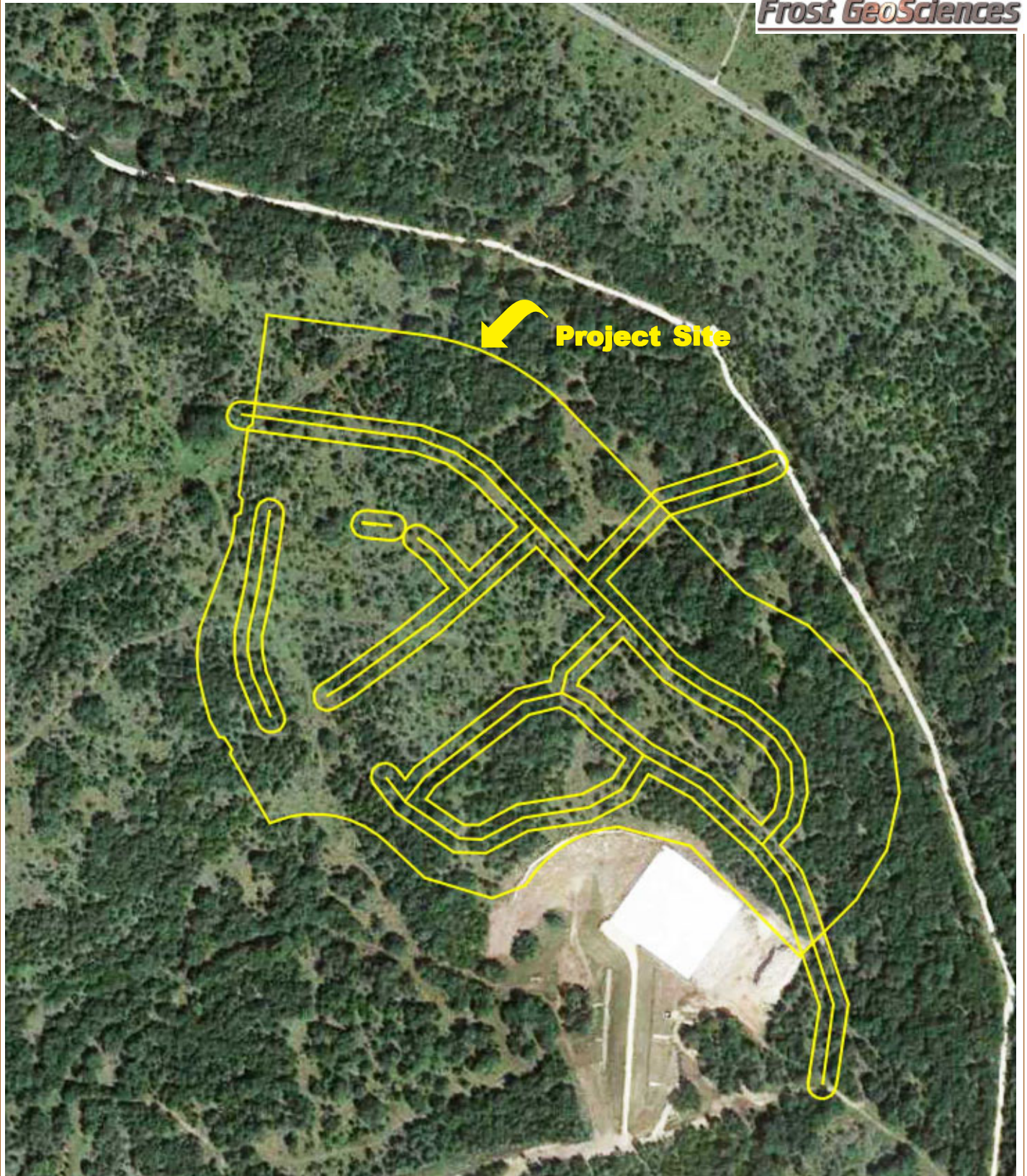

**PROJECT NAME:**

Geologic Site Assessment (SCS)  
for Regulated Activities / Development on the  
Edwards Aquifer Recharge / Transition Zone  
Veramendi Subdivision, Units 18-2 & 19-1  
New Braunfels, Texas

2023 Aerial Photograph  
Google Earth

**PROJECT NO.:**

FGS-E23192

**DATE:**

February 15, 2024

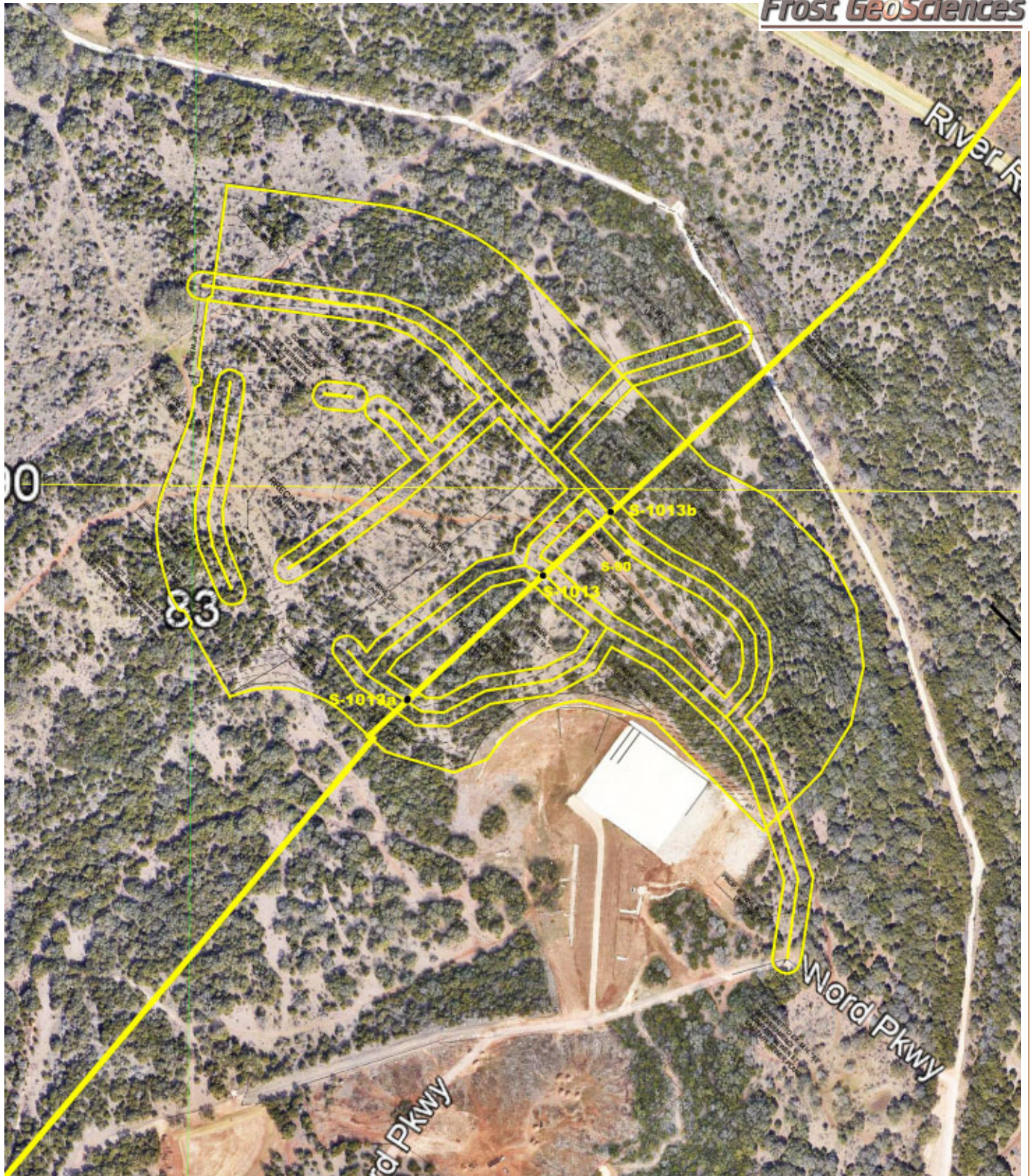

**PROJECT NAME:**

Geologic Site Assessment (SCS)  
for Regulated Activities / Development on the  
Edwards Aquifer Recharge / Transition Zone  
Veramendi Subdivision, Units 18-2 & 19-1  
New Braunfels, Texas

2023 Aerial Photograph with PRF's  
Google Earth

**PROJECT NO.:**

FGS-E23192

**DATE:**

February 15, 2024

## Appendix B

### Site Inspection Photographs



View of PRF # S-1014 near Area 1.



View to the north from PRF # S-1014 near Area 1.



Typical view of vegetative cover on the project site near Area 2.



Typical view of vegetative cover on the project site near Area 2.



Typical view of vegetative cover on the project site near Area 3.



Typical view of vegetative cover on the project site near Area 3.



Typical view of vegetative cover on the project site near Area 4.



Typical view of vegetative cover on the project site near Area 4.



Typical view of vegetative cover on the project site near Area 5.

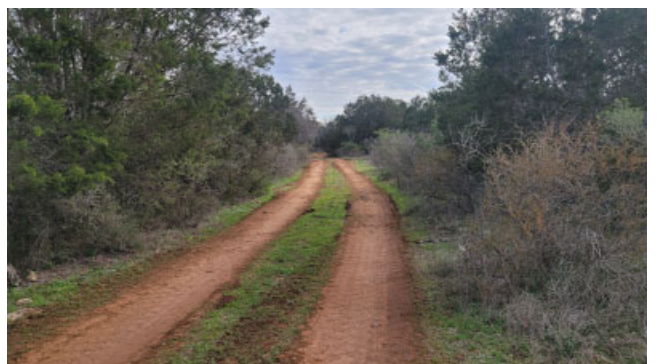

Typical view of vegetative cover on the project site near Area 5.



Typical view of vegetative cover on the project site near Area 6.



Typical view of vegetative cover on the project site near Area 7.





Typical view of vegetative cover on the project site near Area 7.



Typical view of vegetative cover on the project site near Area 7.



Typical view of vegetative cover on the project site near Area 8.



Typical view of vegetative cover on the project site near Area 8.



Typical view of vegetative cover on the project site near Area 9.



Typical view of vegetative cover on the project site near Area 9.



Typical view of vegetative cover on the project site near Area 10.



Typical view of vegetative cover on the project site near Area 10.

# Appendix C

## Site Geologic Map

# Organized Sewage Collection System Application

## Texas Commission on Environmental Quality

For Regulated Activities on the Edwards Aquifer Recharge Zone and Relating to 30 TAC §213.5(c), Effective June 1, 1999

**To ensure that the application is administratively complete, confirm that all fields in the form are complete, verify that all requested information is provided, consistently reference the same site and contact person in all forms in the application, and ensure forms are signed by the appropriate party.**

**Note: Including all the information requested in the form and attachments contributes to more streamlined technical reviews.**

Regulated Entity Name: Veramendi Precincts 18-2 & 19-1

1.  **Attachment A – SCS Engineering Design Report.** This Engineering Design Report is provided to fulfill the requirements of 30 TAC Chapter 217, including 217.10 of Subchapter A, §§217.51 – 217.70 of Subchapter C, and Subchapter D as applicable, and is required to be submitted with this SCS Application Form.

## Customer Information

2. The entity and contact person responsible for providing the required engineering certification of testing for this sewage collection system upon completion (including private service connections) and every five years thereafter to the appropriate TCEQ region office pursuant to 30 TAC §213.5(c) is:

Contact Person: Priscilla G. Flores, PE.

Entity: LJA Engineering

Mailing Address: 9830 Colonnade Blvd, Ste 300

City, State: San Antonio, TX

Zip: 78256

Telephone: 210-503-2700

Fax: \_\_\_\_\_

Email Address: pflores@lja.com

**The appropriate regional office must be informed of any changes in this information within 30 days of the change.**

3. The engineer responsible for the design of this sewage collection system is:

Contact Person: Priscilla G. Flores, PE.

Texas Licensed Professional Engineer's Number: 109874

Entity: LJA Engineering

Mailing Address: 9830 Colonnade Blvd, Ste 300

City, State: San Antonio, TX

Zip: 78256

Telephone: 210-503-2700

Fax: \_\_\_\_\_

Email Address: pflores@lja.com



New Braunfels Utilities

9. The sewage collection system will convey the wastewater to the \_\_\_\_\_ (name) Treatment Plant. The treatment facility is:

- Existing
- Proposed

10. All components of this sewage collection system will comply with:

- The City of <sup>New Braunfels</sup> \_\_\_\_\_ standard specifications.
- Other. Specifications are attached.

11.  No force main(s) and/or lift station(s) are associated with this sewage collection system.

A force main(s) and/or lift station(s) is associated with this sewage collection system and the **Lift Station/Force Main System Application** form (TCEQ-0624) is included with this application.

**Alignment**

12.  There are no deviations from uniform grade in this sewage collection system without manholes and with open cut construction.

13.  There are no deviations from straight alignment in this sewage collection system without manholes.

**Attachment B - Justification and Calculations for Deviation in Straight Alignment without Manholes.** A justification for deviations from straight alignment in this sewage collection system without manholes with documentation from pipe manufacturer allowing pipe curvature is attached.

For curved sewer lines, all curved sewer line notes (TCEQ-0596) are included on the construction plans for the wastewater collection system.

**Manholes and Cleanouts**

14.  Manholes or clean-outs exist at the end of each sewer line(s). These locations are listed below: (Please attach additional sheet if necessary)

**Table 2 - Manholes and Cleanouts** Veramendi Precint 19-1

<i>Line</i>	<i>Shown on Sheet</i>	<i>Station</i>	<i>Manhole or Clean-out?</i>
WWL 'A'	40 Of 61	1+00	Manhole 'A'
WWL 'A'	40 Of 61	3+89.02	Manhole 'A-1'
WWL 'A'	40 Of 61	7+81.51	Manhole 'A-2'
WWL 'A'	40 Of 61	8+81.11	Manhole 'A-3'
WWL 'A'	40 Of 61	10+25.78	Manhole 'A-4'
WWL 'A'	40 Of 61	11+56.75	Manhole 'A-5'
WWL 'A'	40 Of 61	12+56.09	Manhole 'A-6'

<i>Line</i>	<i>Shown on Sheet</i>	<i>Station</i>	<i>Manhole or Clean-out?</i>
WWL 'A'	40 Of 61	13+52.81	Manhole 'A-7'
WWL 'A'	40 Of 61	14+52.02	Manhole 'A-8'
WWL 'A'	40 Of 61	16+00.12	Manhole 'A-9'

15.  Manholes are installed at all Points of Curvature and Points of Termination of a sewer line.
16.  The maximum spacing between manholes on this project for each pipe diameter is no greater than:

SEE ATTACHED FOR TABLE 2 CONTINUATION for Veramendi Precint 19-1 & 18-2

<b>Pipe Diameter (inches)</b>	<b>Max. Manhole Spacing (feet)</b>
6 - 15	500
16 - 30	800
36 - 48	1000
≥54	2000

- Attachment C – Justification for Variance from Maximum Manhole Spacing.** The maximum spacing between manholes on this project (for each pipe diameter used) is greater than listed in the table above. A justification for any variance from the maximum spacing is attached, and must include a letter from the entity which will operate and maintain the system stating that it has the capability to maintain lines with manhole spacing greater than the allowed spacing.
17.  All manholes will be monolithic, cast-in-place concrete.
- The use of pre-cast manholes is requested for this project. The manufacturer's specifications and construction drawings, showing the method of sealing the joints, are attached.

## ***Site Plan Requirements***

***Items 18 - 25 must be included on the Site Plan.***

18.  The Site Plan must have a minimum scale of 1" = 400'.  
Site Plan Scale: 1" = 50 '.
19.  The Site Plan must include the sewage collection system general layout, including manholes with station numbers, and sewer pipe stub outs (if any). Site plan must be overlain by topographic contour lines, using a contour interval of not greater than ten feet and showing the area within both the five-year floodplain and the 100-year floodplain of any drainage way.
20. Lateral stub-outs:
- The location of all lateral stub-outs are shown and labeled.
- No lateral stub-outs will be installed during the construction of this sewer collection system.

21. Location of existing and proposed water lines:

- The entire water distribution system for this project is shown and labeled.
- If not shown on the Site Plan, a Utility Plan is provided showing the entire water and sewer systems.
- There will be no water lines associated with this project.

22. 100-year floodplain:

- After construction is complete, no part of this project will be in or cross a 100-year floodplain, either naturally occurring or manmade. (Do not include streets or concrete-lined channels constructed above of sewer lines.)
- After construction is complete, all sections located within the 100-year floodplain will have water-tight manholes. These locations are listed in the table below and are shown and labeled on the Site Plan. (Do not include streets or concrete-lined channels constructed above sewer lines.)

**Table 3 - 100-Year Floodplain**

<i>Line</i>	<i>Sheet</i>	<i>Station</i>
WWL 'A'	51 of 71	0+80 to 1+53.69
	of	to
	of	to
	of	to

23. 5-year floodplain:

- After construction is complete, no part of this project will be in or cross a 5-year floodplain, either naturally occurring or man-made. (Do not include streets or concrete-lined channels constructed above sewer lines.)
- After construction is complete, all sections located within the 5-year floodplain will be encased in concrete or capped with concrete. These locations are listed in the table below and are shown and labeled on the Site Plan. (Do not include streets or concrete-lined channels constructed above sewer lines.)

**Table 4 - 5-Year Floodplain**

<i>Line</i>	<i>Sheet</i>	<i>Station</i>
	of	to
	of	to
	of	to
	of	to

24.  Legal boundaries of the site are shown.

25.  The **final plans and technical specifications** are submitted for the TCEQ's review. Each sheet of the construction plans and specifications are dated, signed, and sealed by the Texas Licensed Professional Engineer responsible for the design on each sheet.



**Items 26 - 33 must be included on the Plan and Profile sheets.**

26.  All existing or proposed water line crossings and any parallel water lines within 9 feet of sewer lines are listed in the table below. These lines must have the type of pressure rated pipe to be installed shown on the plan and profile sheets. Any request for a variance from the required pressure rated piping at crossings must include a variance approval from 30 TAC Chapter 290.

- There will be no water line crossings.
- There will be no water lines within 9 feet of proposed sewer lines.

**Table 5 - Water Line Crossings VERAMENDI PRECINCT 18-2**

<i>Line</i>	<i>Station or Closest Point</i>	<i>Crossing or Parallel</i>	<i>Horizontal Separation Distance</i>	<i>Vertical Separation Distance</i>
EX WWL 'A'	14+32.92	Crossing		Vertical
EX WWL 'A'	27+13.24	Crossing		Vertical
WWL 'A'	8+97.61	Crossing		Vertical
WWL 'A'	9+98.50	Crossing		Vertical
WWL 'A'	11+60.16	Crossing		Vertical
WWL 'B'	1+15.55	Crossing		Vertical
WWL 'B'	4+22.12	Crossing		Vertical

**27 Vented Manholes:**

SEE ATTACHED FOR TABLE 5  
CONTINUATION - Veramendi Precinct 19-1

- No part** of this sewer line is within the 100-year floodplain and vented manholes are not required by 30 TAC Chapter 217.
- A portion** of this sewer line is within the 100-year floodplain and vented manholes will be provided at less than 1500 foot intervals. These water-tight manholes are listed in the table below and labeled on the appropriate profile sheets.
- A portion** of this sewer line is within the 100-year floodplain and an alternative means of venting shall be provided at less than 1500 feet intervals. A description of the alternative means is described on the following page.
- A portion** of this sewer line is within the 100-year floodplain; however, there is no interval longer than 1500 feet located within. No vented manholes will be used.

**Table 6 - Vented Manholes**

<i>Line</i>	<i>Manhole</i>	<i>Station</i>	<i>Sheet</i>

<i>Line</i>	<i>Manhole</i>	<i>Station</i>	<i>Sheet</i>

28. Drop manholes:

- There are no drop manholes associated with this project.
- Sewer lines which enter new or existing manholes or "manhole structures" higher than 24 inches above the manhole invert are listed in the table below and labeled on the appropriate profile sheets. These lines meet the requirements of 30 TAC §217.55(l)(2)(H).

**Table 7 - Drop Manholes**

<i>Line</i>	<i>Manhole</i>	<i>Station</i>	<i>Sheet</i>

29. Sewer line stub-outs (For proposed extensions):

- The placement and markings of all sewer line stub-outs are shown and labeled.
- No sewer line stub-outs are to be installed during the construction of this sewage collection system.

30. Lateral stub-outs (For proposed private service connections):

- The placement and markings of all lateral stub-outs are shown and labeled.
- No lateral stub-outs are to be installed during the construction of this sewage collection system.

31. Minimum flow velocity (From Appendix A)

- Assuming pipes are flowing full; all slopes are designed to produce flows equal to or greater than 2.0 feet per second for this system/line.

32. Maximum flow velocity/slopes (From Appendix A)

- Assuming pipes are flowing full, all slopes are designed to produce maximum flows of less than or equal to 10 feet per second for this system/line.
- Attachment D – Calculations for Slopes for Flows Greater Than 10.0 Feet per Second.** Assuming pipes are flowing full, some slopes produce flows which are greater than 10 feet per second. These locations are listed in the table below. Calculations are attached.

**Table 8 - Flows Greater Than 10 Feet per Second**

<i>Line</i>	<i>Profile Sheet</i>	<i>Station to Station</i>	<i>FPS</i>	<i>% Slope</i>	<i>Erosion/Shock Protection</i>

33. Assuming pipes are flowing full, where flows are  $\geq 10$  feet per second, the provisions noted below have been made to protect against pipe displacement by erosion and/or shock under 30 TAC §217.53(l)(2)(B).

- Concrete encasement shown on appropriate Plan and Profile sheets for the locations listed in the table above.
- Steel-reinforced, anchored concrete baffles/retards placed every 50 feet shown on appropriate Plan and Profile sheets for the locations listed in the table above.
- N/A

**Administrative Information**

- 34.  The final plans and technical specifications are submitted for TCEQ review. Each sheet of the construction plans and specifications are dated, signed, and sealed by the Texas Licensed Professional Engineer responsible for the design on each sheet.
- 35.  Standard details are shown on the detail sheets, which are dated, signed, and sealed by the Texas Licensed Professional Engineer, as listed in the table below:

**Table 9 - Standard Details**

<b>Standard Details</b>	<b>Shown on Sheet</b>
Lateral stub-out marking <b>[Required]</b>	N/A
Manhole, showing inverts comply with 30 TAC §217.55(l)(2) <b>[Required]</b>	49 of 71 & 38 of 61
Alternate method of joining lateral to existing SCS line for potential future connections <b>[Required]</b>	N/A
Typical trench cross-sections <b>[Required]</b>	49 of 71 & 30 of 61
Bolted manholes <b>[Required]</b>	61 of 71 & 49 of 61
Sewer Service lateral standard details <b>[Required]</b>	61 of 71 & 49 of 61
Clean-out at end of line <b>[Required, if used]</b>	61 of 71 & 49 of 61
Baffles or concrete encasement for shock/erosion protection <b>[Required, if flow velocity of any section of pipe &gt;10 fps]</b>	N/A
Detail showing Wastewater Line/Water Line Crossing <b>[Required, if crossings are proposed]</b>	49 of 71 & 30 of 61
Mandrel detail or specifications showing compliance with 30 TAC §217.57(b) and (c) <b>[Required, if Flexible Pipe is used]</b>	61 of 71 & 49 of 61

<b>Standard Details</b>	<b>Shown on Sheet</b>
Drop manholes [Required, if a pipe entering a manhole is more than 24 inches above manhole invert]	N/A

36.  All organized sewage collection system general construction notes (TCEQ-0596) are included on the construction plans for this sewage collection system.
37.  All proposed sewer lines will be sufficiently surveyed/staked to allow an assessment prior to TCEQ executive director approval. If the alignments of the proposed sewer lines are not walkable on that date, the application will be deemed incomplete and returned.
- Survey staking was completed on this date: \_\_\_\_\_
38.  Submit one (1) original and one (1) copy of the application, plus additional copies as needed for each affected incorporated city, groundwater conservation district, and county in which the project will be located. The TCEQ will distribute the additional copies to these jurisdictions. The copies must be submitted to the appropriate regional office.
39.  Any modification of this SCS application will require TCEQ approval, prior to construction, and may require submission of a revised application, with appropriate fees.

### **Signature**

To the best of my knowledge, the responses to this form accurately reflect all information requested concerning the proposed regulated activities and methods to protect the Edwards Aquifer. This **Organized Sewage Collection System Application** is hereby submitted for TCEQ review and executive director approval. The system was designed in accordance with the requirements of 30 TAC §213.5(c) and 30 TAC §217 and prepared by:

Print Name of Licensed Professional Engineer: Priscilla Flores, PE

Date: 3-14-2024

Place engineer's seal here:

Signature of Licensed Professional Engineer:

Priscilla G Flores



## Appendix A-Flow Velocity Table

**Flow Velocity (Flowing Full)** All gravity sewer lines on the Edwards Aquifer Recharge Zone shall be designed and constructed with hydraulic slopes sufficient to give a velocity when flowing full of not less than 2.0 feet per second, and not greater than 10 feet per second. The grades shown in the following table are based on Manning's formula and an n factor of 0.013 and shall be the minimum and maximum acceptable slopes unless provisions are made otherwise.

**Table 10 - Slope Velocity**

<b>Pipe Diameter(Inches)</b>	<b>% Slope required for minimum flow velocity of 2.0 fps</b>	<b>% Slope which produces flow velocity of 10.0 fps</b>
6	0.50	12.35
8	0.33	8.40
10	0.25	6.23
12	0.20	4.88
15	0.15	3.62
18	0.11	2.83
21	0.09	2.30
24	0.08	1.93
27	0.06	1.65
30	0.055	1.43
33	0.05	1.26
36	0.045	1.12
39	0.04	1.01
>39	*	*

*\*For lines larger than 39 inches in diameter, the slope may be determined by Manning's formula (as shown below) to maintain a minimum velocity greater than 2.0 feet per second when flowing full and a maximum velocity less than 10 feet per second when flowing full.*

$$v = \frac{1.49}{n} \times R_h^{0.67} \times \sqrt{S}$$

**Figure 1 - Manning's Formula**

Where:

v = velocity (ft/sec)  
n = Manning's roughness coefficient (0.013)  
Rh = hydraulic radius (ft)  
S = slope (ft/ft)

**Veramendi Precint 19-1****Table 2 - Manholes and Cleanouts**

<b>Line</b>	<b>Shown on Sheet</b>	<b>Station</b>	<b>Manhole or Clean-out</b>
WWL 'A'	40 Of 61	17+68.75	Manhole 'A-10'
WWL 'A'	39 Of 61	19+20.98	Manhole 'A-11'
WWL 'B'	40 Of 61	4+01	Manhole 'B-1'
WWL 'B'	39 Of 61	6+38.07	Manhole 'B-2'
WWL 'B'	39 Of 61	8+32.48	Manhole 'B-3'
WWL 'B'	39 Of 61	9+16.23	Manhole 'B-4'
WWL 'B'	39 Of 61	10+11.03	Manhole 'B-5'
WWL 'C'	39 Of 61	2+45.60	Manhole 'C-1'
WWL 'C'	38 Of 61	3+84.20	Manhole 'C-2'
WWL 'C'	38 Of 61	6+21.42	Manhole 'C-3'
WWL 'C'	38 Of 61	7+85.83	Manhole 'C-4'
WWL 'C'	38 Of 61	8+68.08	Manhole 'C-5'
WWL 'C'	38 Of 61	11+02.65	Manhole 'C-6'
WWL 'C'	38 Of 61	12+14.88	Manhole 'C-7'
WWL 'D'	38 Of 61	2+12.04	Manhole 'D-1'
WWL 'D'	38 Of 61	4+89.35	Manhole 'D-2'
WWL 'E'	39 Of 61	2+55	Manhole 'E-1'
WWL 'E'	39 Of 61	5+38.88	Manhole 'E-2'
WWL 'E'	39 Of 61	7+56.47	Manhole 'E-3'

**Veramendi Precint 18-2****Table 2 - Manholes and Cleanouts**

<b>Line</b>	<b>Shown on Sheet</b>	<b>Station</b>	<b>Manhole or Clean-out</b>
WWL 'A'	51 Of 71	0+80	Manhole Ex 'MH 7'
WWL 'A'	51 Of 71	1+53.69	Manhole 'A-1'
WWL 'A'	51 Of 71	5+25.14	Manhole 'A-2'
WWL 'A'	51 Of 71	9+10.80	Manhole 'A-3'
WWL 'A'	51 Of 71	11+75.76	Manhole 'A-4'
WWL 'A'	51 Of 71	14+50.94	Manhole 'A-5'
WWL 'A'	50 Of 71	15+83	Manhole 'A-6'
WWL 'A'	50 Of 71	17+14.04	Manhole 'A-7'
WWL 'A'	50 Of 71	20+03.81	Manhole 'A-8'
WWL 'A'	50 Of 71	23+16.08	Manhole 'A-9'
WWL 'B'	51 Of 71	4+34.68	Manhole 'B-1'
WWL 'B'	49 Of 71	6+27.43	Manhole 'B-2'
WWL 'B'	49 Of 71	10+02.84	Manhole 'B-3'
WWL 'B'	49 Of 71	10+66.88	Manhole 'B-4'
WWL 'C'	51 Of 71	2+81.66	Manhole 'C-1'
WWL 'C'	50 Of 71	3+61.65	Manhole 'C-2'
WWL 'D'	50 Of 71	1+23.50	Manhole 'D-1'
WWL 'D'	49 Of 71	2+69.39	Manhole 'D-2'
WWL 'D'	49 Of 71	3+70.39	Manhole 'D-3'
WWL 'D'	49 Of 71	5+43.66	Manhole 'D-4'
WWL 'D'	49 Of 71	6+04.79	Manhole 'D-5'
WWL 'D'	49 Of 71	6+94.20	Manhole 'D-6'
WWL 'E'	49 Of 71	1+28.50	Manhole 'E-1'
WWL 'F'	50 Of 71	1+94.15	Manhole 'F-1'

**Veramendi Precint 19-1****Table 5 - Water Line Crossings**

<b>Line</b>	<b>Station or Closest Point</b>	<b>Crossing or Parallel</b>	<b>Horizontal Separation Distance</b>	<b>Vertical Separation Distance</b>
WWL 'A'	10+08.44	Crossing		6.23
WWL 'C'	1+13.73	Crossing		6.23
WWL 'C'	10+88.13	Crossing		2.42
WWL 'E'	2+35.05	Crossing		3.77
WWL 'E'	6+23.38	Crossing		3.05



**Texas Commission on Environmental Quality  
Organized Sewage Collection System  
General Construction Notes**

**Edwards Aquifer Protection Program Construction Notes – Legal Disclaimer**

*The following/listed “construction notes” are intended to be advisory in nature only and do not constitute an approval or conditional approval by the Executive Director, nor do they constitute a comprehensive listing of rules or conditions to be followed during construction. Further actions may be required to achieve compliance with TCEQ regulations found in Title 30, Texas Administrative Code, Chapters 213 and 217, as well as local ordinances and regulations providing for the protection of water quality. Additionally, nothing contained in the following/listed “construction notes” restricts the powers of the Executive Director, the commission or any other governmental entity to prevent, correct, or curtail activities that result or may result in pollution of the Edwards Aquifer or hydrologically connected surface waters. The holder of any Edwards Aquifer Protection Plan containing “construction notes” is still responsible for compliance with Title 30, Texas Administrative Code, Chapters 213 or any other applicable TCEQ regulation, as well as all conditions of an Edwards Aquifer Protection Plan through all phases of plan implementation. Failure to comply with any condition of the Executive Director’s approval, whether or not in contradiction of any “construction notes,” is a violation of TCEQ regulations and any violation is subject to administrative rules, orders, and penalties as provided under Title 30, Texas Administrative Code § 213.10 (relating to Enforcement). Such violations may also be subject to civil penalties and injunction. The following/listed “construction notes” in no way represent an approved exception by the Executive Director to any part of Title 30 Texas Administrative Code, Chapters 213 and 217, or any other TCEQ applicable regulation.*

1. This Organized Sewage Collection System (SCS) must be constructed in accordance with 30 Texas Administrative Code (TAC) §213.5(c), the Texas Commission on Environmental Quality’s (TCEQ) Edwards Aquifer Rules and any local government standard specifications.
2. All contractors conducting regulated activities associated with this proposed regulated project must be provided with copies of the SCS plan and the TCEQ letter indicating the specific conditions of its approval. During the course of these regulated activities, the contractors must be required to keep on-site copies of the plan and the approval letter.
3. A written notice of construction must be submitted to the presiding TCEQ regional office at least 48 hours prior to the start of any regulated activities. This notice must include:
  - the name of the approved project;
  - the activity start date; and
  - the contact information of the prime contractor.
4. Any modification to the activities described in the referenced SCS application following the date of approval may require the submittal of an SCS application to modify this approval, including the payment of appropriate fees and all information necessary for its review and approval.
5. Prior to beginning any construction activity, all temporary erosion and sedimentation (E&S) control measures must be properly installed and maintained in accordance with the manufacturers specifications. These controls must remain in place until the disturbed areas have been permanently stabilized.
6. If any sensitive features are discovered during the wastewater line trenching activities, all regulated activities near the sensitive feature must be suspended immediately. The applicant must immediately notify the appropriate regional office of the TCEQ of the feature discovered. A geologist’s assessment of the location and extent of the feature discovered must be reported to that regional office in writing and the applicant must submit a plan for ensuring the structural integrity of the sewer line or for modifying the proposed collection system alignment around the feature. The regulated activities near the sensitive feature may not proceed until the

executive director has reviewed and approved the methods proposed to protect the sensitive feature and the Edwards Aquifer from any potentially adverse impacts to water quality while maintaining the structural integrity of the line.

7. Sewer lines located within or crossing the 5-year floodplain of a drainage way will be protected from inundation and stream velocities which could cause erosion and scouring of backfill. The trench must be capped with concrete to prevent scouring of backfill, or the sewer lines must be encased in concrete. All concrete shall have a minimum thickness of 6 inches.
8. Blasting procedures for protection of existing sewer lines and other utilities will be in accordance with the National Fire Protection Association criteria. Sand is not allowed as bedding or backfill in trenches that have been blasted. If any existing sewer lines are damaged, the lines must be repaired and retested.
9. All manholes constructed or rehabilitated on this project must have watertight size on size resilient connectors allowing for differential settlement. If manholes are constructed within the 100-year floodplain, the cover must have a gasket and be bolted to the ring. Where gasketed manhole covers are required for more than three manholes in sequence or for more than 1500 feet, alternate means of venting will be provided. Bricks are not an acceptable construction material for any portion of the manhole.

The diameter of the manholes must be a minimum of four feet and the manhole for entry must have a minimum clear opening diameter of 30 inches. These dimensions and other details showing compliance with the commission's rules concerning manholes and sewer line/manhole inverts described in 30 TAC §217.55 are included on Plan Sheet \_\_\_ of \_\_\_.

It is suggested that entrance into manholes in excess of four feet deep be accomplished by means of a portable ladder. The inclusion of steps in a manhole is prohibited.

10. Where water lines and new sewer line are installed with a separation distance closer than nine feet (i.e., water lines crossing wastewater lines, water lines paralleling wastewater lines, or water lines next to manholes) the installation must meet the requirements of 30 TAC §217.53(d) (Pipe Design) and 30 TAC §290.44(e) (Water Distribution).
11. Where sewers lines deviate from straight alignment and uniform grade all curvature of sewer pipe must be achieved by the following procedure which is recommended by the pipe manufacturer: \_\_\_\_\_.

If pipe flexure is proposed, the following method of preventing deflection of the joint must be used: \_\_\_\_\_.

Specific care must be taken to ensure that the joint is placed in the center of the trench and properly bedded in accordance with 30 TAC §217.54.

12. New sewage collection system lines must be constructed with stub outs for the connection of anticipated extensions. The location of such stub outs must be marked on the ground such that their location can be easily determined at the time of connection of the extensions. Such stub outs must be manufactured wyes or tees that are compatible in size and material with both the sewer line and the extension. At the time of original construction, new stub-outs must be constructed sufficiently to extend beyond the end of the street pavement. All stub-outs must be sealed with a manufactured cap to prevent leakage. Extensions that were not anticipated at the time of original construction or that are to be connected to an existing sewer line not furnished with stub outs must be connected using a manufactured saddle and in accordance with accepted plumbing techniques.

If no stub-out is present an alternate method of joining laterals is shown in the detail on Plan Sheet \_\_\_ of \_\_\_. (For potential future laterals).

The private service lateral stub-outs must be installed as shown on the plan and profile sheets on Plan Sheet \_\_\_ of \_\_\_ and marked after backfilling as shown in the detail on Plan Sheet \_\_\_ of \_\_\_.

13. Trenching, bedding and backfill must conform with 30 TAC §217.54. The bedding and backfill for flexible pipe must comply with the standards of ASTM D-2321, Classes IA, IB, II or III. Rigid pipe bedding must comply with the requirements of ASTM C 12 (ANSI A 106.2) classes A, B or C.
14. Sewer lines must be tested from manhole to manhole. When a new sewer line is connected to an existing stub or clean-out, it must be tested from existing manhole to new manhole. If a stub or clean-out is used at the end of the proposed sewer line, no private service attachments may be connected between the last manhole and the cleanout unless it can be certified as conforming with the provisions of 30 TAC §213.5(c)(3)(E).
15. All sewer lines must be tested in accordance with 30 TAC §217.57. The engineer must retain copies of all test results which must be made available to the executive director upon request. The engineer must certify in writing that all wastewater lines have passed all required testing to the appropriate regional office within 30 days of test completion and prior to use of the new collection system. Testing method will be:
  - (a) For a collection system pipe that will transport wastewater by gravity flow, the design must specify an infiltration and exfiltration test or a low-pressure air test. A test must conform to the following requirements:
    - (1) *Low Pressure Air Test.*
      - (A) A low pressure air test must follow the procedures described in American Society For Testing And Materials (ASTM) C-828, ASTM C-924, or ASTM F-1417 or other procedure approved by the executive director, except as to testing times as required in Table C.3 in subparagraph (C) of this paragraph or Equation C.3 in subparagraph (B)(ii) of this paragraph.
      - (B) For sections of collection system pipe less than 36 inch average inside diameter, the following procedure must apply, unless a pipe is to be tested as required by paragraph (2) of this subsection.
        - (i) A pipe must be pressurized to 3.5 pounds per square inch (psi) greater than the pressure exerted by groundwater above the pipe.
        - (ii) Once the pressure is stabilized, the minimum time allowable for the pressure to drop from 3.5 psi gauge to 2.5 psi gauge is computed from the following equation:

Equation C.3 
$$T = \frac{0.085 \times D \times K}{Q}$$

Where:

- T = time for pressure to drop 1.0 pound per square inch gauge in seconds  
K = 0.000419 X D X L, but not less than 1.0  
D = average inside pipe diameter in inches

L = length of line of same size being tested, in feet  
 Q = rate of loss, 0.0015 cubic feet per minute per square foot internal surface

(C) Since a K value of less than 1.0 may not be used, the minimum testing time for each pipe diameter is shown in the following Table C.3:

Pipe Diameter (inches)	Minimum Time (seconds)	Maximum Length for Minimum Time (feet)	Time for Longer Length (seconds/foot)
6	340	398	0.855
8	454	298	1.520
10	567	239	2.374
12	680	199	3.419
15	850	159	5.342
18	1020	133	7.693
21	1190	114	10.471
24	1360	100	13.676
27	1530	88	17.309
30	1700	80	21.369
33	1870	72	25.856

- (D) An owner may stop a test if no pressure loss has occurred during the first 25% of the calculated testing time.
- (E) If any pressure loss or leakage has occurred during the first 25% of a testing period, then the test must continue for the entire test duration as outlined above or until failure.
- (F) Wastewater collection system pipes with a 27 inch or larger average inside diameter may be air tested at each joint instead of following the procedure outlined in this section.
- (G) A testing procedure for pipe with an inside diameter greater than 33 inches must be approved by the executive director.

(2) *Infiltration/Exfiltration Test.*

- (A) The total exfiltration, as determined by a hydrostatic head test, must not exceed 50 gallons per inch of diameter per mile of pipe per 24 hours at a minimum test head of 2.0 feet above the crown of a pipe at an upstream manhole.
- (B) An owner shall use an infiltration test in lieu of an exfiltration test when pipes are installed below the groundwater level.
- (C) The total exfiltration, as determined by a hydrostatic head test, must not exceed 50 gallons per inch diameter per mile of pipe per 24 hours at a minimum test head of two feet above the crown of a pipe at an upstream manhole, or at least two feet above existing groundwater level, whichever is greater.
- (D) For construction within a 25-year flood plain, the infiltration or exfiltration must not exceed 10 gallons per inch diameter per mile of pipe per 24 hours at the same minimum test head as in subparagraph (C) of this paragraph.
- (E) If the quantity of infiltration or exfiltration exceeds the maximum quantity specified, an owner shall undertake remedial action in order to reduce

the infiltration or exfiltration to an amount within the limits specified. An owner shall retest a pipe following a remediation action.

- (b) If a gravity collection pipe is composed of flexible pipe, deflection testing is also required. The following procedures must be followed:
  - (1) For a collection pipe with inside diameter less than 27 inches, deflection measurement requires a rigid mandrel.
    - (A) *Mandrel Sizing.*
      - (i) A rigid mandrel must have an outside diameter (OD) not less than 95% of the base inside diameter (ID) or average ID of a pipe, as specified in the appropriate standard by the ASTMs, American Water Works Association, UNI-BELL, or American National Standards Institute, or any related appendix.
      - (ii) If a mandrel sizing diameter is not specified in the appropriate standard, the mandrel must have an OD equal to 95% of the ID of a pipe. In this case, the ID of the pipe, for the purpose of determining the OD of the mandrel, must equal be the average outside diameter minus two minimum wall thicknesses for OD controlled pipe and the average inside diameter for ID controlled pipe.
      - (iii) All dimensions must meet the appropriate standard.
    - (B) *Mandrel Design.*
      - (i) A rigid mandrel must be constructed of a metal or a rigid plastic material that can withstand 200 psi without being deformed.
      - (ii) A mandrel must have nine or more odd number of runners or legs.
      - (iii) A barrel section length must equal at least 75% of the inside diameter of a pipe.
      - (iv) Each size mandrel must use a separate proving ring.
    - (C) *Method Options.*
      - (i) An adjustable or flexible mandrel is prohibited.
      - (ii) A test may not use television inspection as a substitute for a deflection test.
      - (iii) If requested, the executive director may approve the use of a deflectometer or a mandrel with removable legs or runners on a case-by-case basis.
  - (2) For a gravity collection system pipe with an inside diameter 27 inches and greater, other test methods may be used to determine vertical deflection.
  - (3) A deflection test method must be accurate to within plus or minus 0.2% deflection.
  - (4) An owner shall not conduct a deflection test until at least 30 days after the final backfill.
  - (5) Gravity collection system pipe deflection must not exceed five percent (5%).
  - (6) If a pipe section fails a deflection test, an owner shall correct the problem and conduct a second test after the final backfill has been in place at least 30 days.

16. All manholes must be tested to meet or exceed the requirements of 30 TAC §217.58.

- (a) All manholes must pass a leakage test.
- (b) An owner shall test each manhole (after assembly and backfilling) for leakage, separate and independent of the collection system pipes, by hydrostatic exfiltration testing, vacuum testing, or other method approved by the executive director.
  - (1) Hydrostatic Testing.

- (A) The maximum leakage for hydrostatic testing or any alternative test methods is 0.025 gallons per foot diameter per foot of manhole depth per hour.
- (B) To perform a hydrostatic exfiltration test, an owner shall seal all wastewater pipes coming into a manhole with an internal pipe plug, fill the manhole with water, and maintain the test for at least one hour.
- (C) A test for concrete manholes may use a 24-hour wetting period before testing to allow saturation of the concrete.

(2) Vacuum Testing.

- (A) To perform a vacuum test, an owner shall plug all lift holes and exterior joints with a non-shrink grout and plug all pipes entering a manhole.
- (B) No grout must be placed in horizontal joints before testing.
- (C) Stub-outs, manhole boots, and pipe plugs must be secured to prevent movement while a vacuum is drawn.
- (D) An owner shall use a minimum 60 inch/lb torque wrench to tighten the external clamps that secure a test cover to the top of a manhole.
- (E) A test head must be placed at the inside of the top of a cone section, and the seal inflated in accordance with the manufacturer's recommendations.
- (F) There must be a vacuum of 10 inches of mercury inside a manhole to perform a valid test.
- (G) A test does not begin until after the vacuum pump is off.
- (H) A manhole passes the test if after 2.0 minutes and with all valves closed, the vacuum is at least 9.0 inches of mercury.

17. All private service laterals must be inspected and certified in accordance with 30 TAC §213.5(c)(3)(I). After installation of and, prior to covering and connecting a private service lateral to an existing organized sewage collection system, a Texas Licensed Professional Engineer, Texas Registered Sanitarian, or appropriate city inspector must visually inspect the private service lateral and the connection to the sewage collection system, and certify that it is constructed in conformity with the applicable provisions of this section. The owner of the collection system must maintain such certifications for five years and forward copies to the appropriate regional office upon request. Connections may only be made to an approved sewage collection system.

<p>Austin Regional Office          12100 Park 35 Circle, Building A          Austin, Texas 78753-1808          Phone (512) 339-2929          Fax (512) 339-3795</p>	<p>San Antonio Regional Office          14250 Judson Road          San Antonio, Texas 78233-4480          Phone (210) 490-3096          Fax (210) 545-4329</p>
---	--

**THESE GENERAL CONSTRUCTION NOTES MUST BE INCLUDED ON THE CONSTRUCTION PLANS PROVIDED TO THE CONTRACTOR AND ALL SUBCONTRACTORS.**



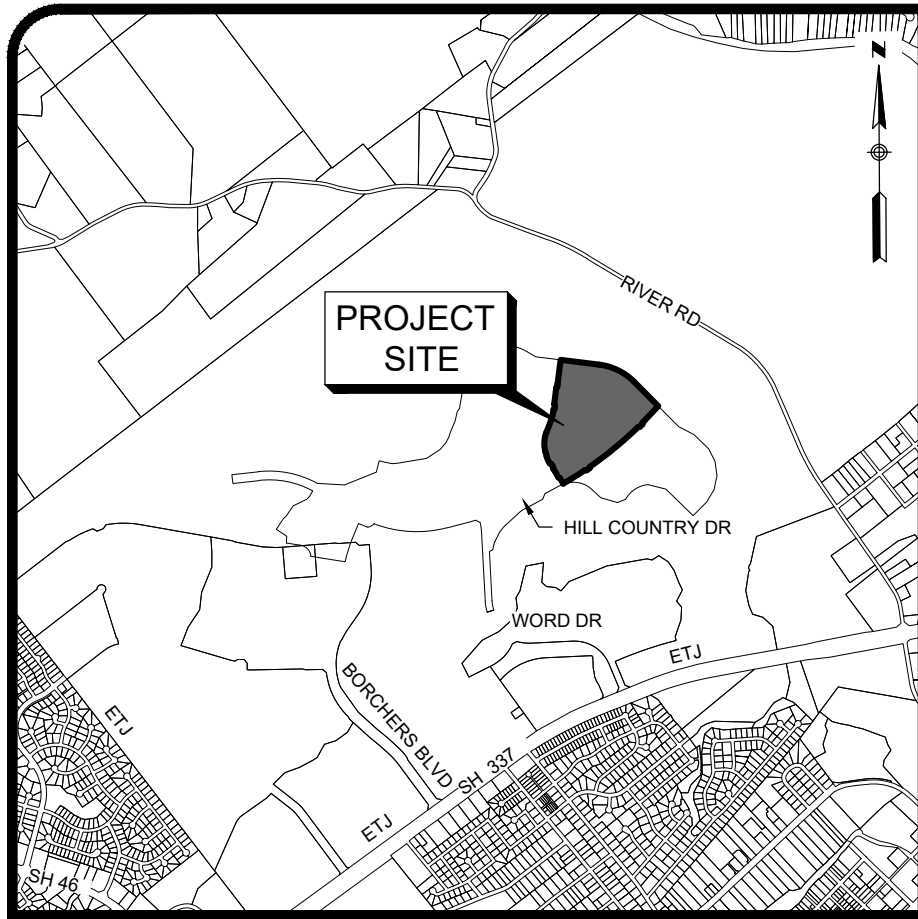

LOCATION MAP  
N.T.S.

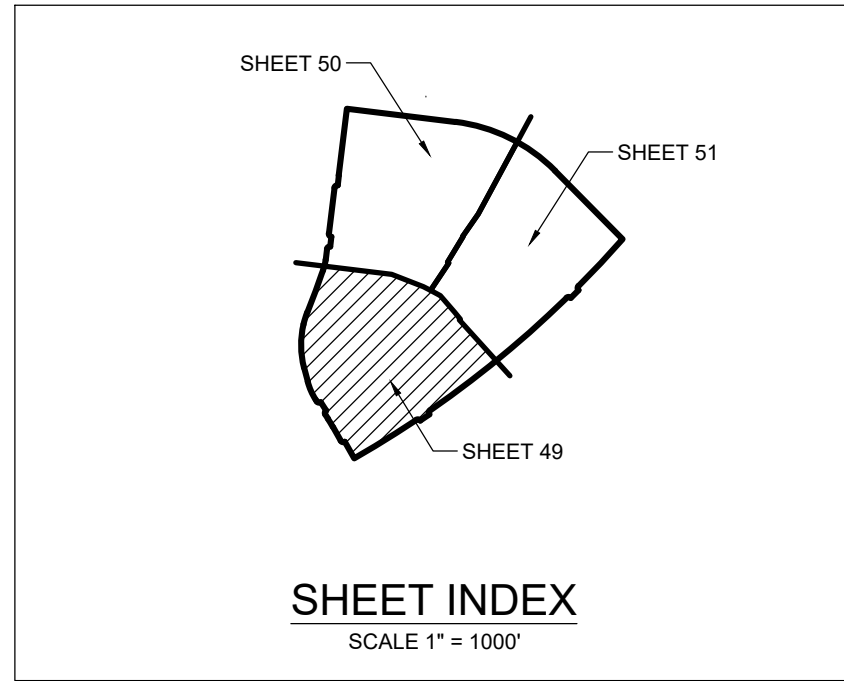
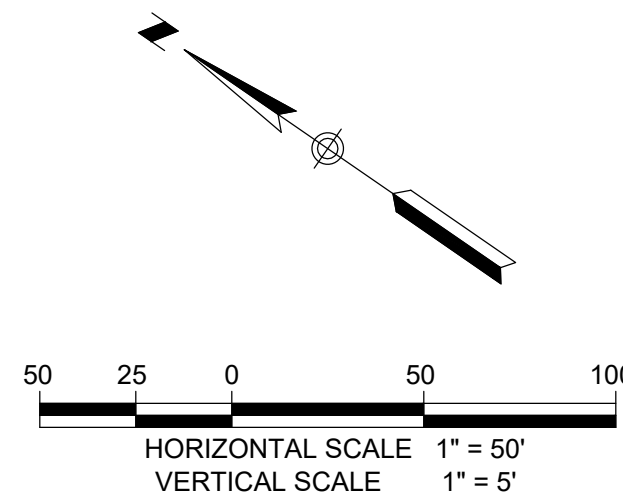

SHEET INDEX  
SCALE 1" = 100'



LEGEND		
PROPOSED	EXISTING	
		SANITARY SEWER MANHOLE
		SANITARY SEWER LINE
		WATER LINE
		SANITARY SEWER LATERAL
		CLEAN OUT (INSTALL BY HOME BUILDER)
		WATER VALVE
		SINGLE WATER SERVICE
		DUAL WATER SERVICE
		FIRE HYDRANT
		PROPOSED SIDEWALK BY DEVELOPER
		WATER METER
		GAS VALVE
		GAS LINE
		STORM SEWER MANHOLE
		CURB INLET
		POWER POLE
		STREET LIGHT (100 WATT LED)
		STREET LIGHT (250 WATT LED)
		GUY WIRE
		OVERHEAD ELECTRIC
		BENCHMARK
		TOP OF MANHOLE
		EXISTING
		UTILITY EASEMENT
		EASEMENT
		VOLUME
		PAGE
		UTILITY X-ING

- NOTES:
- CONTRACTOR TO FIELD VERIFY EXACT LOCATION OF ALL EXISTING UTILITIES HORIZONTALLY AND VERTICALLY PRIOR TO CONSTRUCTION.
  - MANDREL TESTING WILL BE REQUIRED ON ALL FLEXIBLE GRAVITY WASTEWATER PIPE AS PRE TCEQ RULES.
  - ALL GRAVITY WASTEWATER LINES SHALL BE SDR-26 WWL ASTM D3034 UNLESS OTHERWISE NOTED.
  - CONTRACTOR TO FILL AND COMPACT TO 95% DENSITY IN FILL SECTIONS OVER WASTEWATER LINES. 2.0"(MIN.) COVER OVER WATER PRIOR TO CONSTRUCTION.
  - ALL SERVICES SHALL TERMINATE WITH A 2-WAY CLEANOUT.
  - ALL ON-SITE UTILITIES SHALL BE LOCATED UNDERGROUND UNLESS REQUIRED BY THE UTILITY TO BE OTHERWISE LOCATED (SECTION 25-2-1125).
  - WHERE THE MINIMUM 9 FOOT SEPARATION DISTANCE BETWEEN WASTEWATER LINES AND WATER LINES / MAINS CANNOT BE MAINTAINED, THE INSTALLATION OF WASTEWATER LINES SHALL BE IN STRICT ACCORDANCE WITH TCEQ. THE WASTEWATER LINE SHALL BE CONSTRUCTED OF CAST IRON, DUCTILE IRON OR PVC MEETING THE ASTM SPECIFICATION FOR BOTH PIPES AND JOINTS OF 150 PSI AND SHALL BE IN ACCORDANCE WITH 30 TAC § 217.53 (D) (3) (A) (I).

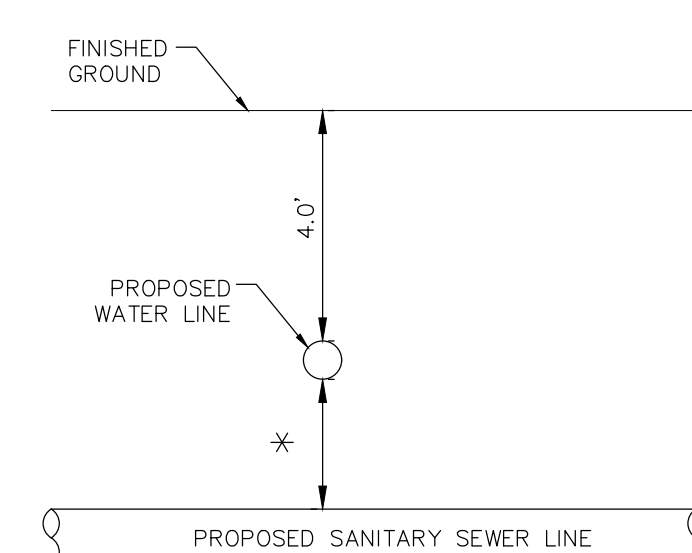

TYPICAL SANITARY SEWER/WATER CROSSING DETAIL  
N.T.S.

**CAUTION:**  
CONTRACTOR TO NOTIFY TEXAS ONE CALL AT 1-800-245-4545 48 HOURS PRIOR TO CONSTRUCTION FOR UTILITY LINE LOCATE. CONTRACTOR SHALL VERIFY HORIZONTAL AND VERTICAL LOCATION OF ALL EXISTING UTILITIES PRIOR TO CONSTRUCTION. ENGINEER SHALL BE NOTIFIED IMMEDIATELY OF ANY SIGNIFICANT DISCREPANCIES OR REQUIRED DESIGN CHANGES. EXISTING UTILITIES SHOWN HEREON ARE FOR INFORMATIONAL PURPOSES ONLY. ENGINEER ASSUMES NO RESPONSIBILITY FOR THE ACCURACY OF THIS INFORMATION.

**TRENCH EXCAVATION SAFETY PROTECTION**  
CONTRACTOR AND/OR CONTRACTOR'S INDEPENDENTLY RETAINED EMPLOYEE OR STRUCTURAL DESIGN/GEOTECHNICAL SAFETY/EQUIPMENT CONSULTANT, IF ANY, SHALL REVIEW THESE PLANS AND AVAILABLE GEOTECHNICAL INFORMATION AND THE ANTICIPATED INSTALLATION SITES WITHIN THE PROJECT WORK AREA IN ORDER TO IMPLEMENT CONTRACTOR'S TRENCH EXCAVATION SAFETY PROTECTION SYSTEMS, PROGRAMS AND/OR PROCEDURES. THE CONTRACTOR'S IMPLEMENTATION OF THE SYSTEMS, PROGRAMS AND/OR PROCEDURES SHALL PROVIDE FOR ADEQUATE TRENCH EXCAVATION SAFETY PROTECTION THAT COMPLIES WITH AS A MINIMUM, OSHA STANDARDS FOR TRENCH EXCAVATIONS. SPECIFICALLY, CONTRACTOR AND/OR CONTRACTOR'S INDEPENDENTLY RETAINED EMPLOYEE OR SAFETY CONSULTANT SHALL IMPLEMENT A TRENCH SAFETY PROGRAM IN ACCORDANCE WITH OSHA STANDARDS GOVERNING THE PRESENCE AND ACTIVITIES OF INDIVIDUALS WORKING IN AND AROUND TRENCH EXCAVATION.

LOCATION OF EXISTING UNDERGROUND AND OVERHEAD UTILITIES ARE APPROXIMATE LOCATIONS ONLY. THE CONTRACTOR SHALL DETERMINE THE EXACT LOCATION OF ALL EXISTING UTILITIES PRIOR TO BEGINNING WORK AND SHALL BE FULLY RESPONSIBLE FOR ANY AND ALL DAMAGES WHICH MIGHT OCCUR.

VERAMENDI PRECINCT 18 UNIT 2  
WASTEWATER LAYOUT (SHEET 1 OF 3)

REVISIONS	DATE	DESCRIPTION
NO.	DATE	DESCRIPTION



**LJA Engineering, Inc.**  
9830 Calumide Blvd  
Suite 300  
San Antonio, Texas 78230  
Phone 210.503.2700  
LJA.COM  
TBP# No. F-1386

JOB NUMBER: SA3856.0402  
SHEET NO. 49 OF 71 SHEETS



FOR PERMIT

K:\QA\856 AC\Progress\85602 Veramendi Precinct 18-2\180223\_Site Development\Drawings\DWG\Sheet50\_WW-wastewaterlayout.dwg  
Last Modified: Nov 20, 2023 10:18:18 AM  
Print Date: Nov 20, 2023 10:18:18 AM



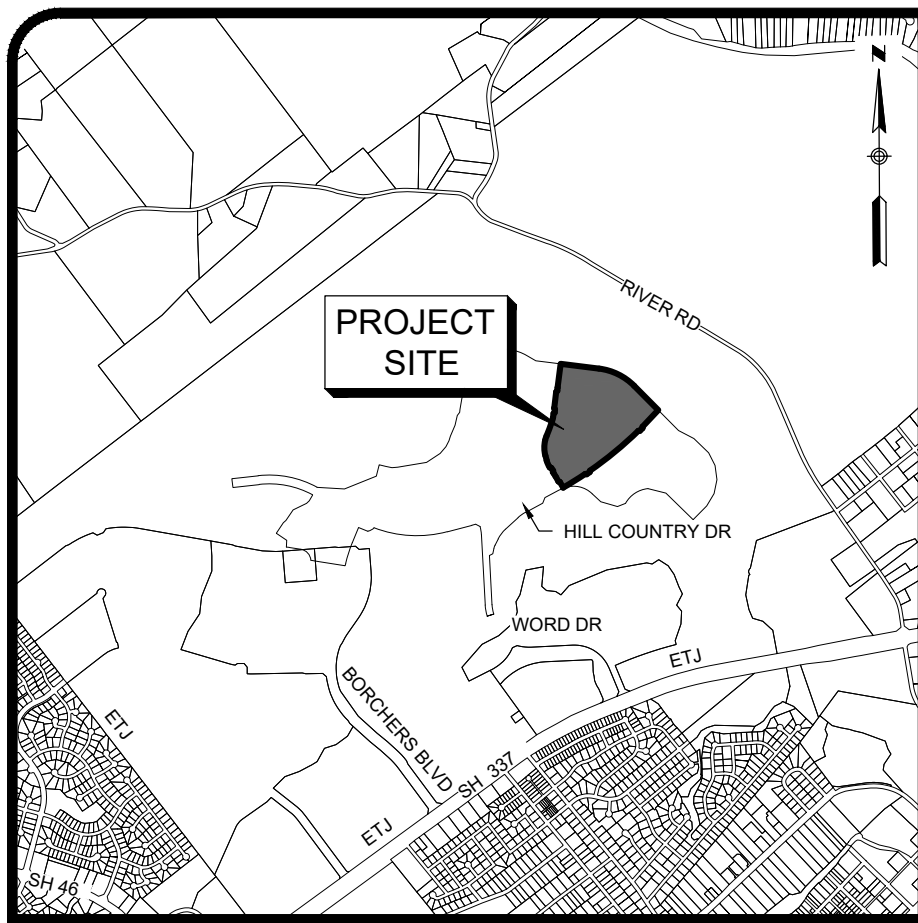

LOCATION MAP  
N.T.S.

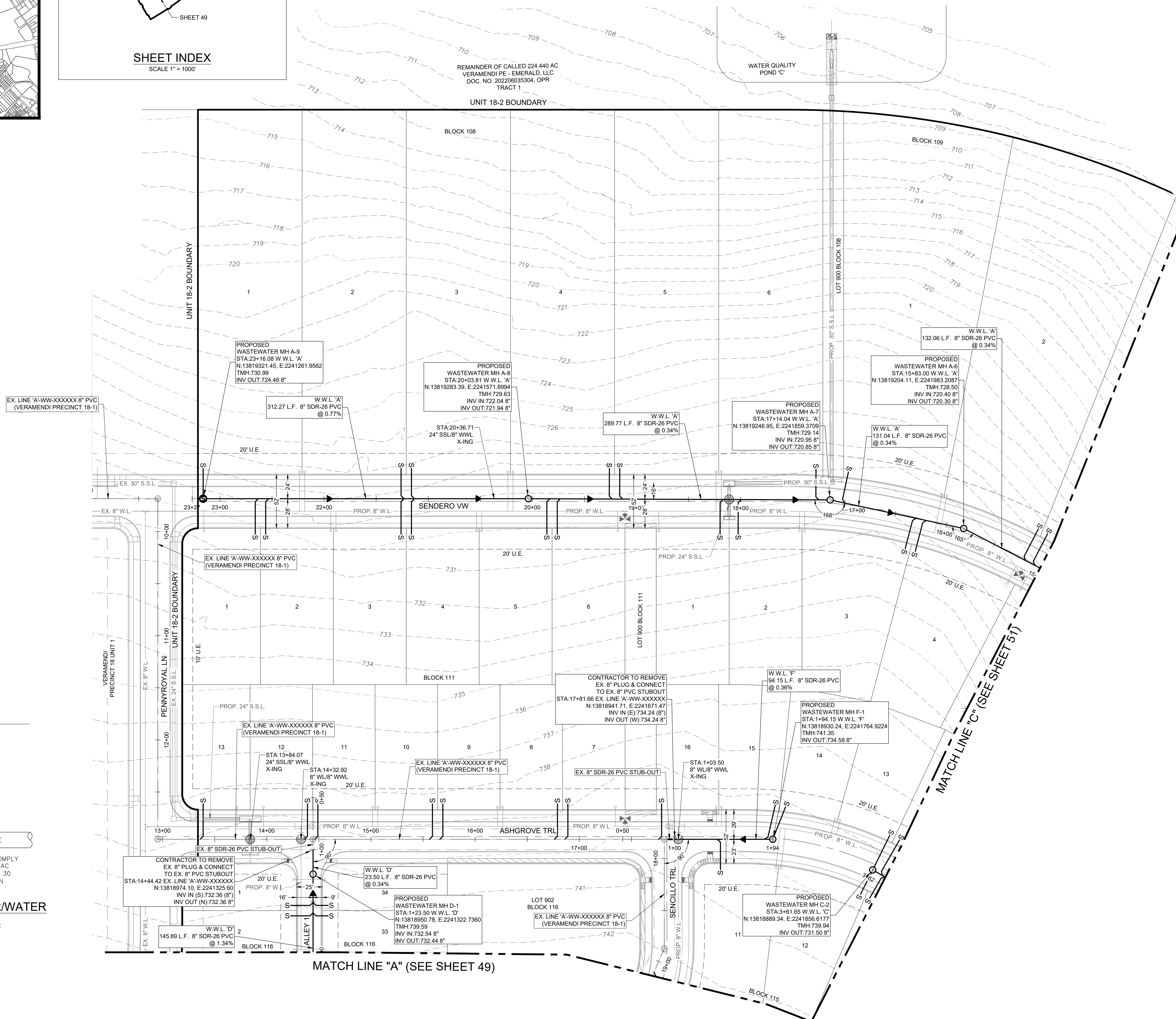
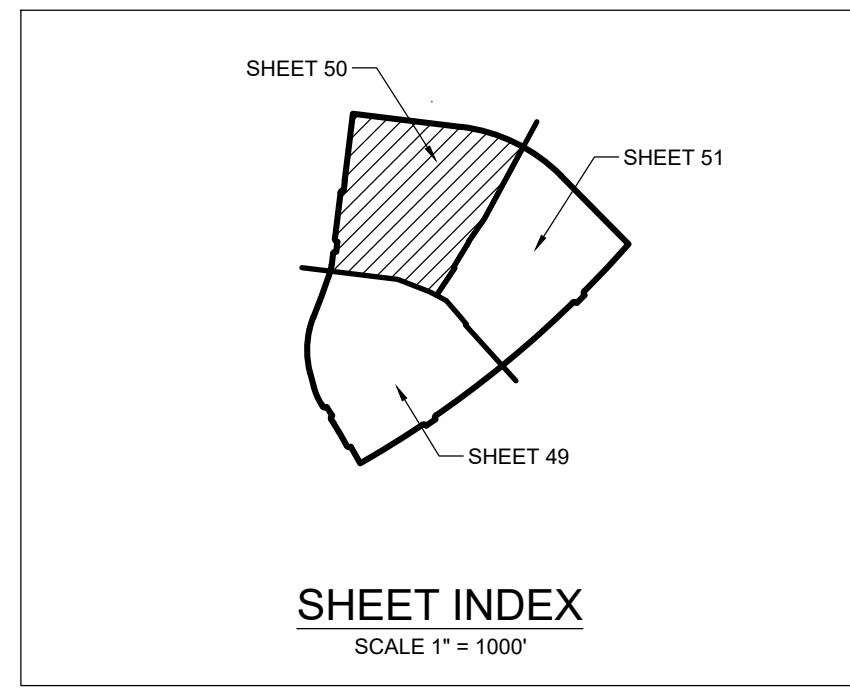
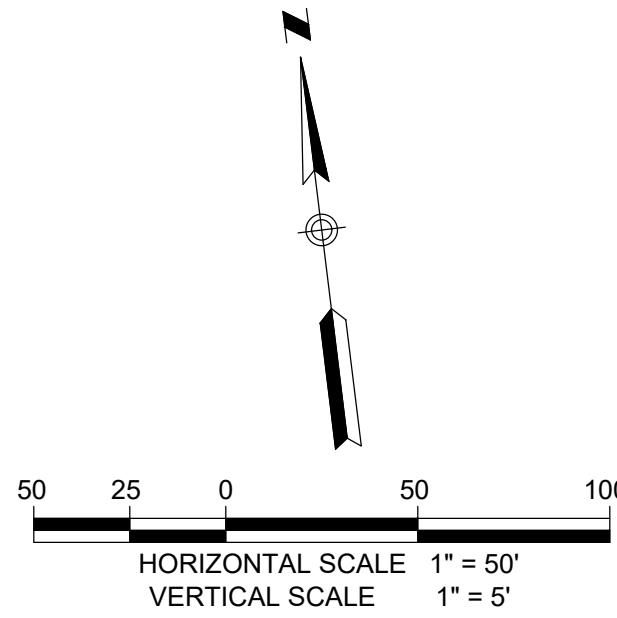

LEGEND		
PROPOSED	EXISTING	
		SANITARY SEWER MANHOLE
		SANITARY SEWER LINE
		WATER LINE
		SANITARY SEWER LATERAL
		CLEAN OUT (INSTALL BY HOME BUILDER)
		WATER VALVE
		SINGLE WATER SERVICE
		DUAL WATER SERVICE
		FIRE HYDRANT
		PROPOSED SIDEWALK BY DEVELOPER
		WATER METER
		GAS VALVE
		GAS LINE
		STORM SEWER MANHOLE
		CURB INLET
		POWER POLE
		STREET LIGHT (100 WATT LED)
		STREET LIGHT (250 WATT LED)
		GUY WIRE
		OVERHEAD ELECTRIC
		BENCHMARK
		TOP OF MANHOLE
		EXISTING
		UTILITY EASEMENT
		EASEMENT
		VOLUME
		PAGE
		UTILITY X-ING

- NOTES:
- CONTRACTOR TO FIELD VERIFY EXACT LOCATION OF ALL EXISTING UTILITIES HORIZONTALLY AND VERTICALLY PRIOR TO CONSTRUCTION.
  - MANDREL TESTING WILL BE REQUIRED ON ALL FLEXIBLE GRAVITY WASTEWATER PIPE AS PRE TCEQ RULES.
  - ALL GRAVITY WASTEWATER LINES SHALL BE SDR-26 WWL ASTM D3034 UNLESS OTHERWISE NOTED.
  - CONTRACTOR TO FILL AND COMPACT TO 95% DENSITY IN FILL SECTIONS OVER WASTEWATER LINES. 2.0"(MIN.) COVER OVER WATER PRIOR TO CONSTRUCTION.
  - ALL SERVICES SHALL TERMINATE WITH A 2-WAY CLEANOUT.
  - ALL ON-SITE UTILITIES SHALL BE LOCATED UNDERGROUND UNLESS REQUIRED BY THE UTILITY TO BE OTHERWISE LOCATED (SECTION 25-2-1125).
  - WHERE THE MINIMUM 9 FOOT SEPARATION DISTANCE BETWEEN WASTEWATER LINES AND WATER LINES / MAINS CANNOT BE MAINTAINED, THE INSTALLATION OF WASTEWATER LINES SHALL BE IN STRICT ACCORDANCE WITH TCEQ. THE WASTEWATER LINE SHALL BE CONSTRUCTED OF CAST IRON, DUCTILE IRON OR PVC MEETING THE ASTM SPECIFICATION FOR BOTH PIPES AND JOINTS OF 150 PSI AND SHALL BE IN ACCORDANCE WITH 30 TAC § 217.53 (D) (3) (A) (I).

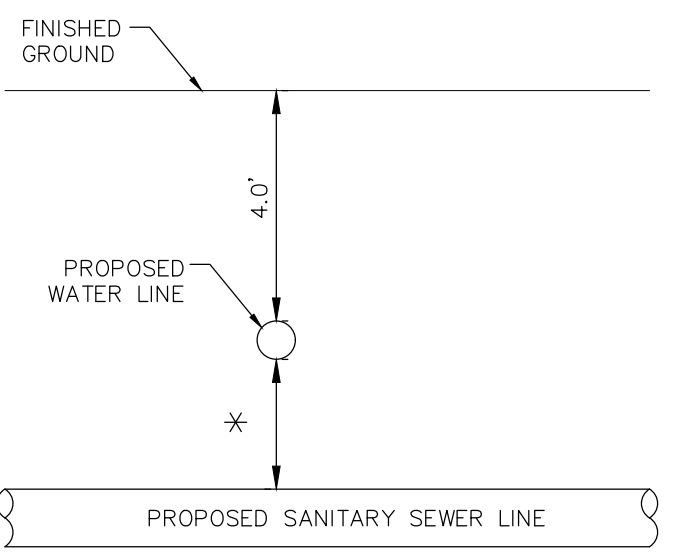

SEPARATION DISTANCE TO COMPLY WITH TCEQ REGULATION 30 TAC 290.44 (E) APPENDIX E AND 30 TAC 217.53(D) - SEPARATION DISTANCE

**CAUTION:** CONTRACTOR TO NOTIFY TEXAS ONE CALL AT 1-800-245-4545 48 HOURS PRIOR TO CONSTRUCTION FOR UTILITY LINE LOCATE. CONTRACTOR SHALL VERIFY HORIZONTAL AND VERTICAL LOCATION OF ALL EXISTING UTILITIES PRIOR TO CONSTRUCTION. ENGINEER SHALL BE NOTIFIED IMMEDIATELY OF ANY SIGNIFICANT DISCREPANCIES OR REQUIRED DESIGN CHANGES. EXISTING UTILITIES SHOWN HEREON ARE FOR INFORMATIONAL PURPOSES ONLY. ENGINEER ASSUMES NO RESPONSIBILITY FOR THE ACCURACY OF THIS INFORMATION.

**TRENCH EXCAVATION SAFETY PROTECTION**  
CONTRACTOR AND/OR CONTRACTOR'S INDEPENDENTLY RETAINED EMPLOYEE OR STRUCTURAL DESIGN/GEOTECHNICAL SAFETY/EQUIPMENT CONSULTANT, IF ANY, SHALL REVIEW THESE PLANS AND AVAILABLE GEOTECHNICAL INFORMATION AND THE ANTICIPATED INSTALLATION SITES) WITHIN THE PROJECT WORK AREA IN ORDER TO IMPLEMENT CONTRACTOR'S TRENCH EXCAVATION SAFETY PROTECTION SYSTEMS, PROGRAMS AND/OR PROCEDURES. THE CONTRACTOR'S IMPLEMENTATION OF THE SYSTEMS, PROGRAMS AND/OR PROCEDURES SHALL PROVIDE FOR ADEQUATE TRENCH EXCAVATION, SAFETY PROTECTION THAT COMPLIES WITH AS A MINIMUM, OSHA STANDARDS FOR TRENCH EXCAVATIONS. SPECIFICALLY, CONTRACTOR AND/OR CONTRACTOR'S INDEPENDENTLY RETAINED EMPLOYEE OR SAFETY CONSULTANT SHALL IMPLEMENT A TRENCH SAFETY PROGRAM IN ACCORDANCE WITH OSHA STANDARDS GOVERNING THE PRESENCE AND ACTIVITIES OF INDIVIDUALS WORKING IN AND AROUND TRENCH EXCAVATION.

LOCATION OF EXISTING UNDERGROUND AND OVERHEAD UTILITIES ARE APPROXIMATE LOCATIONS ONLY. THE CONTRACTOR SHALL DETERMINE THE EXACT LOCATION OF ALL EXISTING UTILITIES PRIOR TO BEGINNING WORK AND SHALL BE FULLY RESPONSIBLE FOR ANY AND ALL DAMAGES WHICH MIGHT OCCUR.



VERAMENDI PRECINCT 18 UNIT 2  
WASTEWATER LAYOUT (SHEET 2 OF 3)

REVISIONS	DATE	DESCRIPTION
NO.		

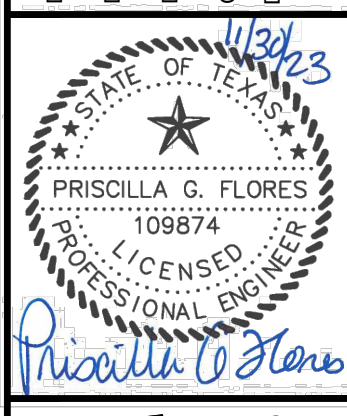

**LJA Engineering, Inc.**  
Phone 210.603.2700  
9830 Calumet Blvd  
Suite 300  
San Antonio, Texas 78230  
TBP# No. F-1386

JOB NUMBER: SA3856.0402  
SHEET NO. **50**  
OF 71 SHEETS

K:\A\3856\_ASA\_Program\3856\_Veremendi\_Precinct\_18-2\450\_Site\_Development\Plan\WWS-Drawings\WWS-WastewaterLayout.dwg  
Last Modified: Nov 20, 2024 10:18 AM  
Plot Date: Nov 20, 2024 10:18 AM

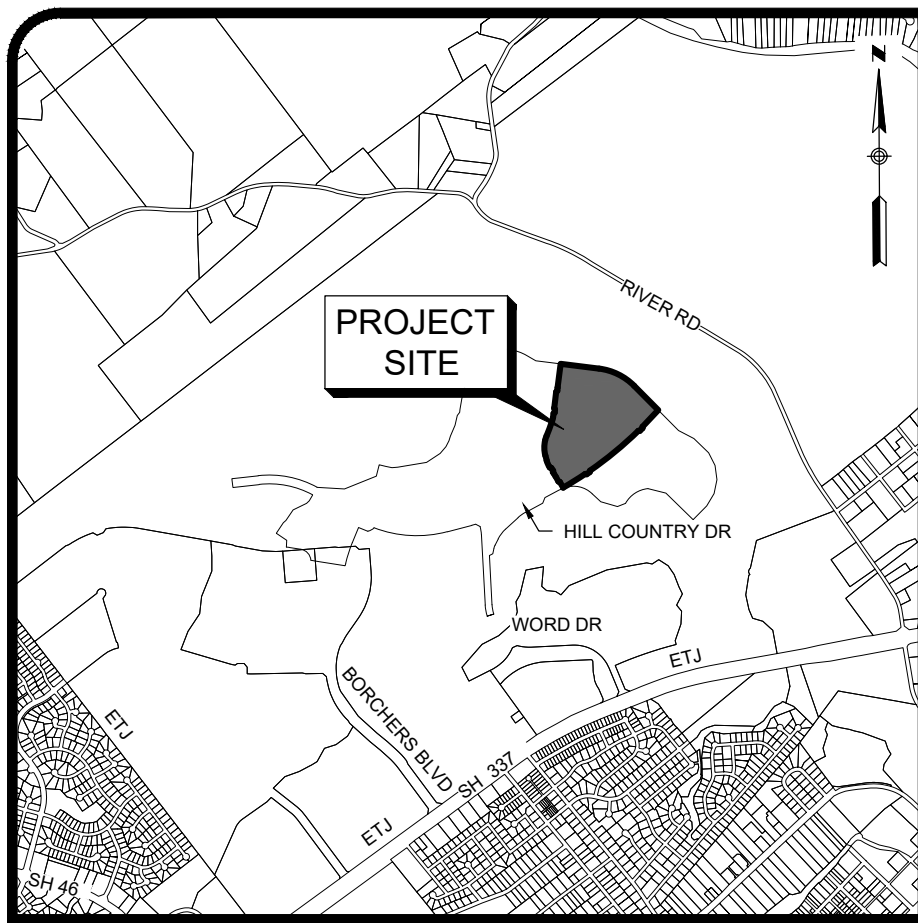

LOCATION MAP  
N.T.S.

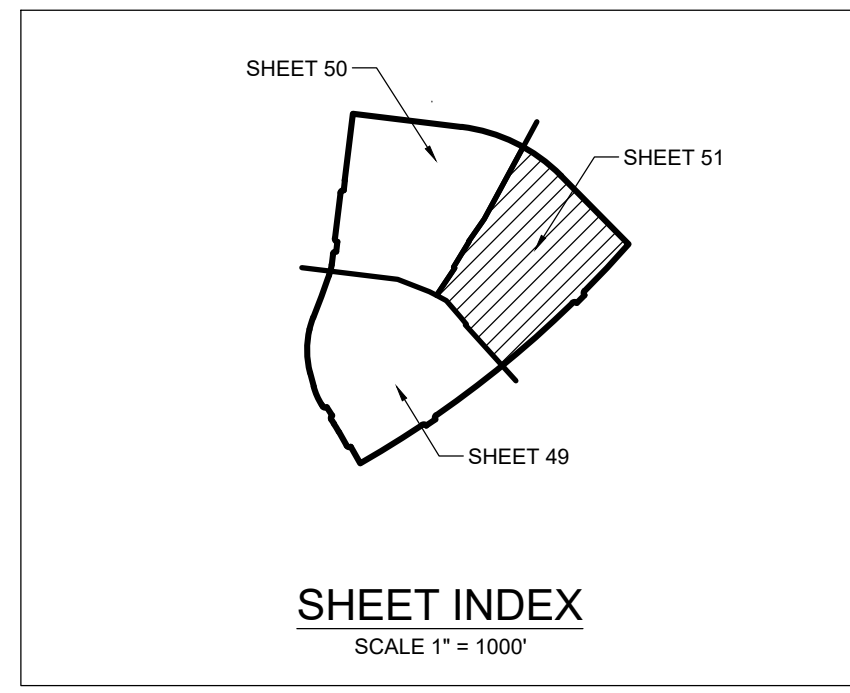
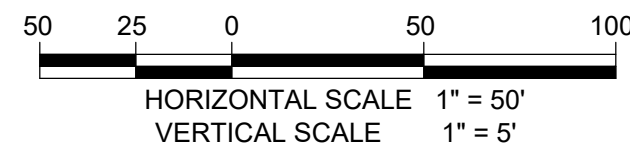

SHEET INDEX  
SCALE 1" = 100'

LEGEND		
PROPOSED	EXISTING	
		SANITARY SEWER MANHOLE
		SANITARY SEWER LINE
		WATER LINE
		SANITARY SEWER LATERAL
		CLEAN OUT (INSTALL BY HOME BUILDER)
		WATER VALVE
		SINGLE WATER SERVICE
		DUAL WATER SERVICE
		FIRE HYDRANT
		PROPOSED SIDEWALK BY DEVELOPER
		WATER METER
		GAS VALVE
		GAS LINE
		STORM SEWER MANHOLE
		CURB INLET
		POWER POLE
		STREET LIGHT (100 WATT LED)
		STREET LIGHT (250 WATT LED)
		GUY WIRE
		OVERHEAD ELECTRIC
		BENCHMARK
		TOP OF MANHOLE
		EXISTING
		UTILITY EASEMENT
		EASEMENT
		VOLUME
		PAGE
		UTILITY X-ING

- NOTES:
- CONTRACTOR TO FIELD VERIFY EXACT LOCATION OF ALL EXISTING UTILITIES HORIZONTALLY AND VERTICALLY PRIOR TO CONSTRUCTION.
  - MANDREL TESTING WILL BE REQUIRED ON ALL FLEXIBLE GRAVITY WASTEWATER PIPE AS PRE TCEQ RULES.
  - ALL GRAVITY WASTEWATER LINES SHALL BE SDR-26 WWL ASTM D3034 UNLESS OTHERWISE NOTED.
  - CONTRACTOR TO FILL AND COMPACT TO 95% DENSITY IN FILL SECTIONS OVER WASTEWATER LINES. 2.0"(MIN.) COVER OVER WATER PRIOR TO CONSTRUCTION.
  - ALL SERVICES SHALL TERMINATE WITH A 2-WAY CLEANOUT.
  - ALL ON-SITE UTILITIES SHALL BE LOCATED UNDERGROUND UNLESS REQUIRED BY THE UTILITY TO BE OTHERWISE LOCATED (SECTION 25-2-1125).
  - WHERE THE MINIMUM 9 FOOT SEPARATION DISTANCE BETWEEN WASTEWATER LINES AND WATER LINES / MAINS CANNOT BE MAINTAINED, THE INSTALLATION OF WASTEWATER LINES SHALL BE IN STRICT ACCORDANCE WITH TCEQ. THE WASTEWATER LINE SHALL BE CONSTRUCTED OF CAST IRON, DUCTILE IRON OR PVC MEETING THE ASTM SPECIFICATION FOR BOTH PIPES AND JOINTS OF 150 PSI AND SHALL BE IN ACCORDANCE WITH 30 TAC § 217.53 (D) (3) (A) (I).

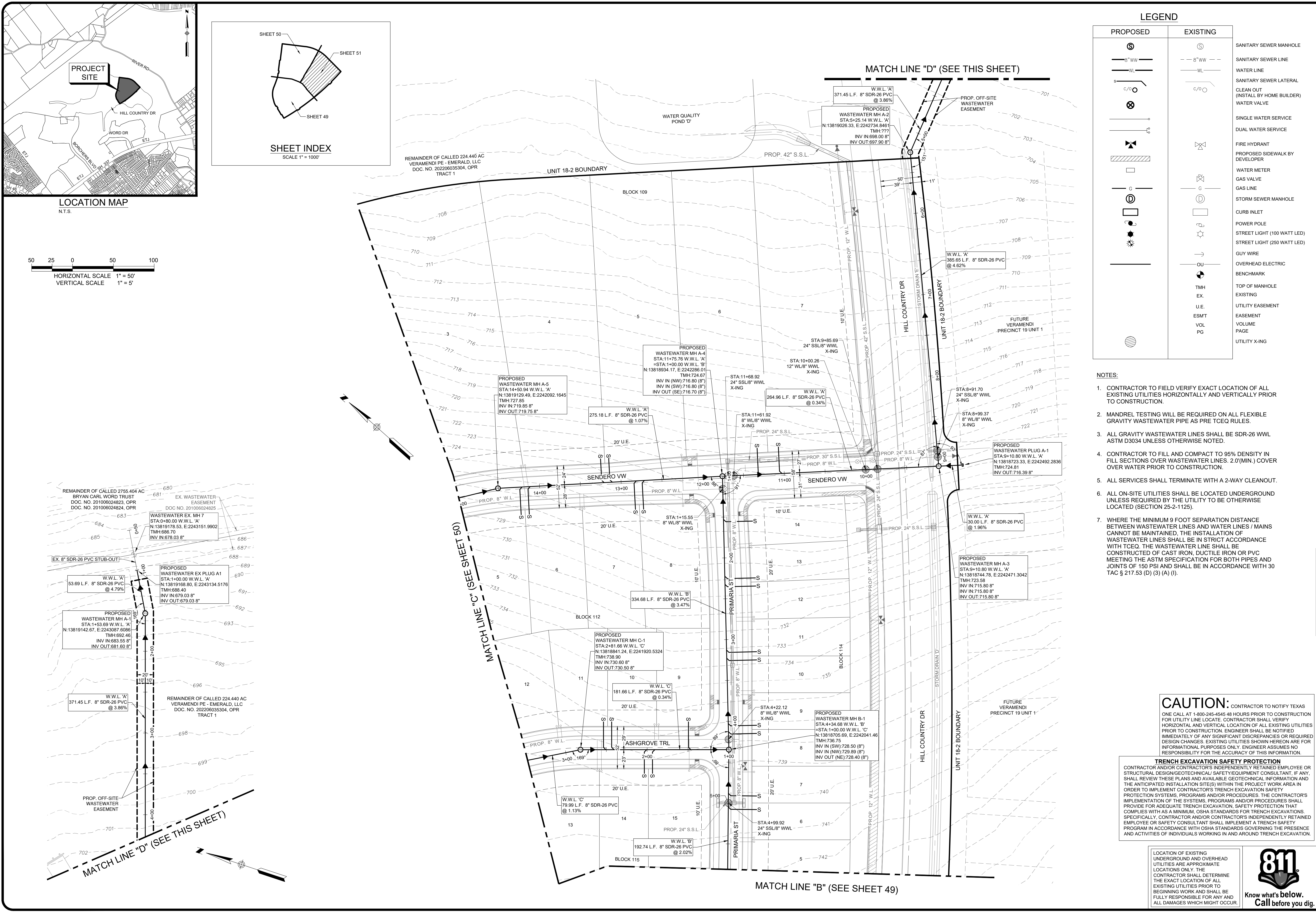

VERAMENDI PRECINCT 18 UNIT 2  
WASTEWATER LAYOUT (SHEET 3 OF 3)

REVISIONS	DATE	DESCRIPTION
NO.	BY	

DATE: 11/03/2023  
DESIGNED BY: NG  
DRAWN BY: MAP  
CHECKED BY: PGF  
DRAWING NAME: 18\_U2\_WWLayout.dwg

**LJA Engineering, Inc.**  
Phone 210.603.2700  
9830 Calomarde Blvd  
Suite 300  
San Antonio, Texas 78230  
TBP# No. F-1386

**CAUTION:** CONTRACTOR TO NOTIFY TEXAS ONE CALL AT 1-800-245-4545 48 HOURS PRIOR TO CONSTRUCTION FOR UTILITY LINE LOCATE. CONTRACTOR SHALL VERIFY HORIZONTAL AND VERTICAL LOCATION OF ALL EXISTING UTILITIES PRIOR TO CONSTRUCTION. ENGINEER SHALL BE NOTIFIED IMMEDIATELY OF ANY SIGNIFICANT DISCREPANCIES OR REQUIRED DESIGN CHANGES. EXISTING UTILITIES SHOWN HEREON ARE FOR INFORMATIONAL PURPOSES ONLY. ENGINEER ASSUMES NO RESPONSIBILITY FOR THE ACCURACY OF THIS INFORMATION.

**TRENCH EXCAVATION SAFETY PROTECTION**  
CONTRACTOR AND/OR CONTRACTOR'S INDEPENDENTLY RETAINED EMPLOYEE OR STRUCTURAL DESIGN/GEOTECHNICAL SAFETY/EQUIPMENT CONSULTANT, IF ANY, SHALL REVIEW THESE PLANS AND AVAILABLE GEOTECHNICAL INFORMATION AND THE ANTICIPATED INSTALLATION SITES) WITHIN THE PROJECT WORK AREA IN ORDER TO IMPLEMENT CONTRACTOR'S TRENCH EXCAVATION SAFETY PROTECTION SYSTEMS, PROGRAMS AND/OR PROCEDURES. THE CONTRACTOR'S IMPLEMENTATION OF THE SYSTEMS, PROGRAMS AND/OR PROCEDURES SHALL PROVIDE FOR ADEQUATE TRENCH EXCAVATION, SAFETY PROTECTION THAT COMPLIES WITH AS A MINIMUM, OSHA STANDARDS FOR TRENCH EXCAVATIONS. SPECIFICALLY, CONTRACTOR AND/OR CONTRACTOR'S INDEPENDENTLY RETAINED EMPLOYEE OR SAFETY CONSULTANT SHALL IMPLEMENT A TRENCH SAFETY PROGRAM IN ACCORDANCE WITH OSHA STANDARDS GOVERNING THE PRESENCE AND ACTIVITIES OF INDIVIDUALS WORKING IN AND AROUND TRENCH EXCAVATION.

LOCATION OF EXISTING UNDERGROUND AND OVERHEAD UTILITIES ARE APPROXIMATE LOCATIONS ONLY. THE CONTRACTOR SHALL DETERMINE THE EXACT LOCATION OF ALL EXISTING UTILITIES PRIOR TO BEGINNING WORK AND SHALL BE FULLY RESPONSIBLE FOR ANY AND ALL DAMAGES WHICH MIGHT OCCUR.



JOB NUMBER: SA3856.0402  
SHEET NO. 51 OF 71 SHEETS  
FOR PERMIT

K:\A\3856\_ASA\_Program\3856\_Veramendi\_Precinct\_18\_U2.dwg Site Development from V:\GIS\Drawings\18\_U2\_WWLayout.dwg  
Last Modified: Nov 03, 2023 10:18 AM  
Plot Date: Nov 03, 2023 10:18 AM



**NOTES:**

- CONTRACTOR TO FIELD VERIFY EXACT LOCATION OF ALL EXISTING UTILITIES HORIZONTALLY AND VERTICALLY PRIOR TO CONSTRUCTION.
- MANDREL TESTING WILL BE REQUIRED ON ALL FLEXIBLE GRAVITY WASTEWATER PIPE AS PRE TCEQ RULES.
- ALL GRAVITY WASTEWATER LINES SHALL BE SDR-26 WWL ASTM D3034 UNLESS OTHERWISE NOTED.
- CONTRACTOR TO FILL AND COMPACT TO 95% DENSITY IN FILL SECTIONS OVER WASTEWATER LINES. 2.0'(MIN.) COVER OVER WATER PRIOR TO CONSTRUCTION.
- ALL SERVICES SHALL TERMINATE WITH A 2-WAY CLEANOUT.
- ALL ON-SITE UTILITIES SHALL BE LOCATED UNDERGROUND UNLESS REQUIRED BY THE UTILITY TO BE OTHERWISE LOCATED (SECTION 25-2-1125).
- WHERE THE MINIMUM 9 FOOT SEPARATION DISTANCE BETWEEN WASTEWATER LINES AND WATER LINES / MAINS CANNOT BE MAINTAINED, THE INSTALLATION OF WASTEWATER LINES SHALL BE IN STRICT ACCORDANCE WITH TCEQ. THE WASTEWATER LINE SHALL BE CONSTRUCTED OF CAST IRON, DUCTILE IRON OR PVC MEETING THE ASTM SPECIFICATION FOR BOTH PIPES AND JOINTS OF 150 PSI AND SHALL BE IN ACCORDANCE WITH 30 TAC § 217.53 (D) (3) (A) (I).

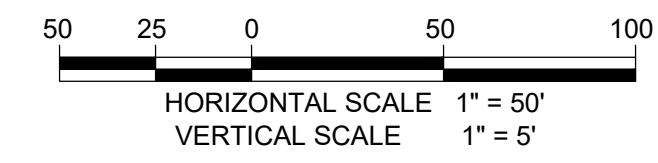

LEGEND		
PROPOSED	EXISTING	
		SANITARY SEWER MANHOLE
		SANITARY SEWER LINE
		WATER LINE
		SANITARY SEWER LATERAL
		CLEAN OUT (INSTALL BY HOME BUILDER)
		WATER VALVE
		SINGLE WATER SERVICE
		DUAL WATER SERVICE
		FIRE HYDRANT
		PROPOSED SIDEWALK BY DEVELOPER
		WATER METER
		GAS VALVE
		GAS LINE
		STORM SEWER MANHOLE
		CURB INLET
		POWER POLE
		STREET LIGHT (100 WATT LED)
		STREET LIGHT (250 WATT LED)
		GUY WIRE
		OVERHEAD ELECTRIC
		BENCHMARK
		TOP OF MANHOLE
		EXISTING
		UTILITY EASEMENT
		EASEMENT
		VOLUME
		PAGE
		UTILITY X-ING

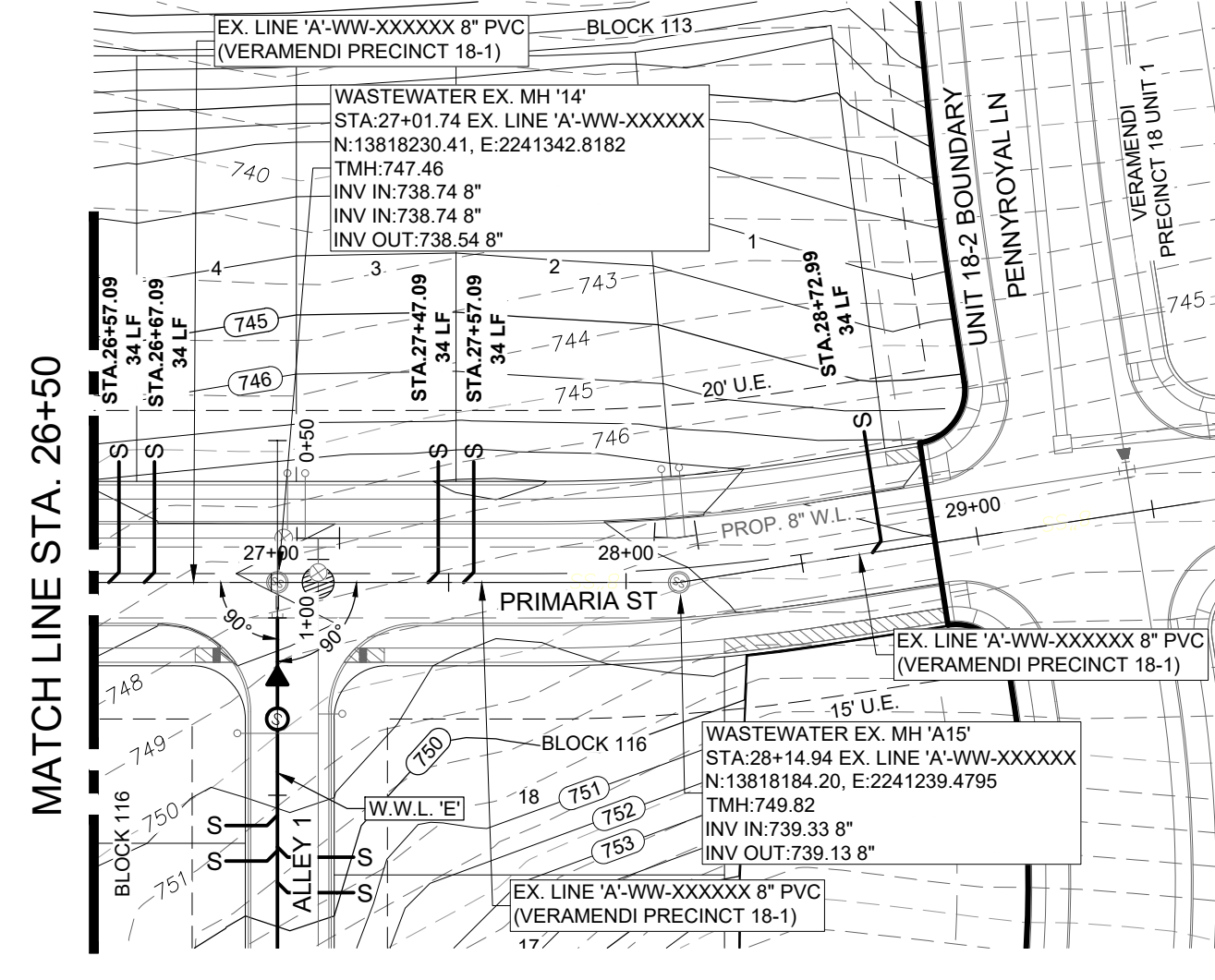
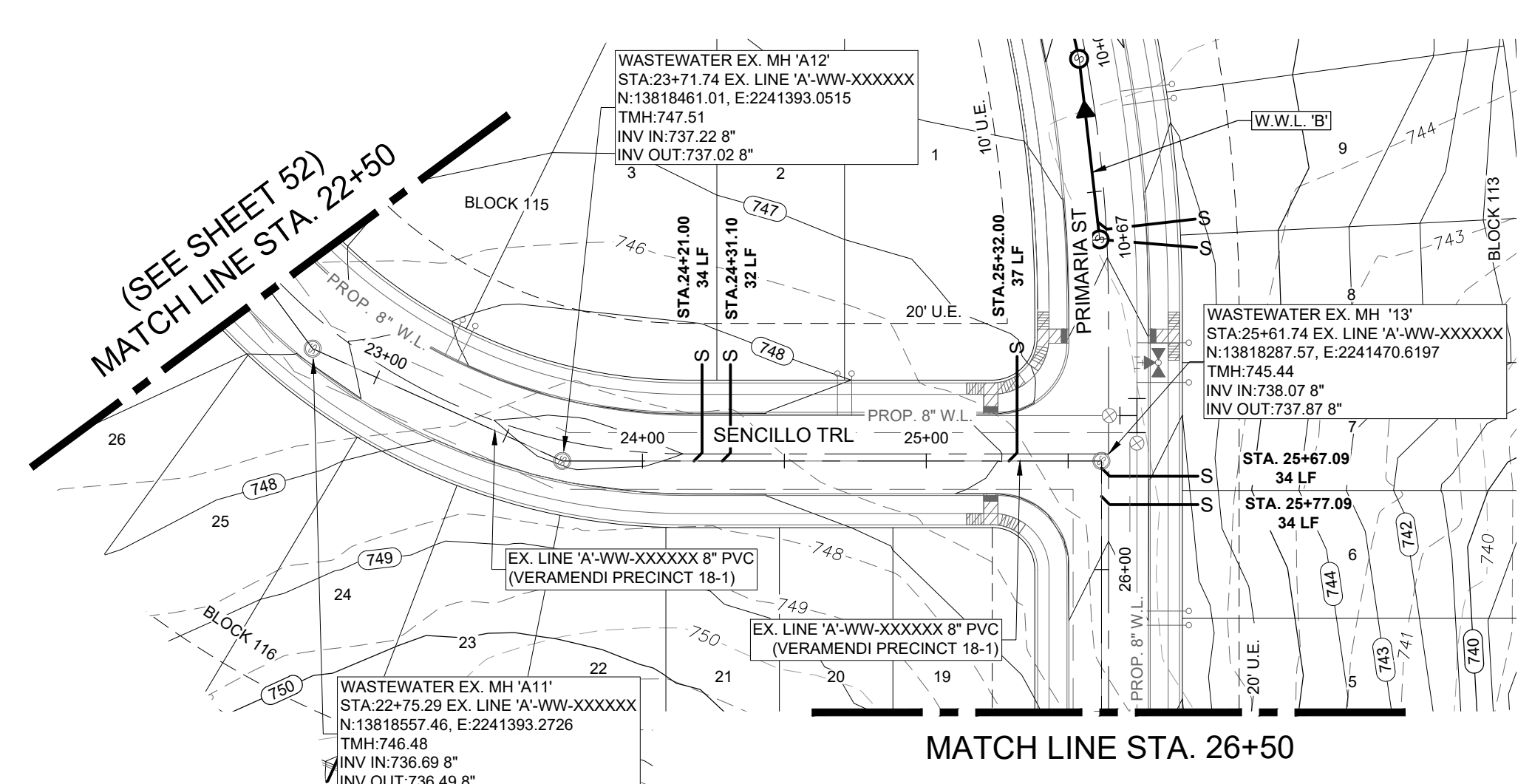

LOCATION OF EXISTING UNDERGROUND AND OVERHEAD UTILITIES ARE APPROXIMATE LOCATIONS ONLY. THE CONTRACTOR SHALL DETERMINE THE EXACT LOCATION OF ALL EXISTING UTILITIES PRIOR TO BEGINNING WORK AND SHALL BE FULLY RESPONSIBLE FOR ANY AND ALL DAMAGES WHICH MIGHT OCCUR.



**EX. WASTEWATER LINE 'A' STA. 22+50 TO END**

**CAUTION:**

CONTRACTOR TO NOTIFY TEXAS ONE CALL AT 1-800-245-4545 48 HOURS PRIOR TO CONSTRUCTION FOR UTILITY LINE LOCATE. CONTRACTOR SHALL VERIFY HORIZONTAL AND VERTICAL LOCATION OF ALL EXISTING UTILITIES PRIOR TO CONSTRUCTION. ENGINEER SHALL BE NOTIFIED IMMEDIATELY OF ANY SIGNIFICANT DISCREPANCIES OR REQUIRED DESIGN CHANGES. EXISTING UTILITIES SHOWN HEREON ARE FOR INFORMATIONAL PURPOSES ONLY. ENGINEER ASSUMES NO RESPONSIBILITY FOR THE ACCURACY OF THIS INFORMATION.

**TRENCH EXCAVATION SAFETY PROTECTION**  
 CONTRACTOR AND/OR CONTRACTOR'S INDEPENDENTLY RETAINED EMPLOYEE OR STRUCTURAL DESIGN/GEOTECHNICAL SAFETY/EQUIPMENT CONSULTANT, IF ANY, SHALL REVIEW THESE PLANS AND AVAILABLE GEOTECHNICAL INFORMATION AND THE ANTICIPATED INSTALLATION SITE(S) WITHIN THE PROJECT WORK AREA IN ORDER TO IMPLEMENT CONTRACTOR'S TRENCH EXCAVATION SAFETY PROTECTION SYSTEMS, PROGRAMS AND/OR PROCEDURES. THE CONTRACTOR'S IMPLEMENTATION OF THE SYSTEMS, PROGRAMS AND/OR PROCEDURES SHALL PROVIDE FOR ADEQUATE TRENCH EXCAVATION, SAFETY PROTECTION THAT COMPLIES WITH AS A MINIMUM, OSHA STANDARDS FOR TRENCH EXCAVATIONS. SPECIFICALLY, CONTRACTOR AND/OR CONTRACTOR'S INDEPENDENTLY RETAINED EMPLOYEE OR SAFETY CONSULTANT SHALL IMPLEMENT A TRENCH SAFETY PROGRAM IN ACCORDANCE WITH OSHA STANDARDS GOVERNING THE PRESENCE AND ACTIVITIES OF INDIVIDUALS WORKING IN AND AROUND TRENCH EXCAVATION.

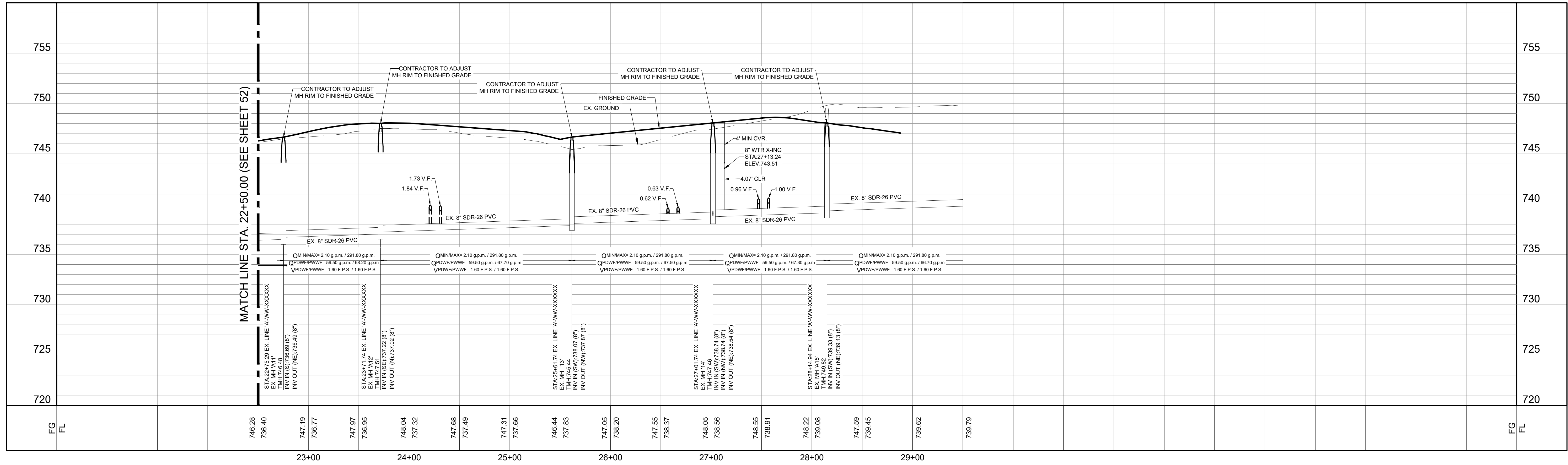

VERAMENDI PRECINCT 18 UNIT 2	
EX. WASTEWATER LINE 'A' PLAN & PROFILE STA. 22+50 TO END	
DATE	11/03/2023
DESIGNED BY	NG
DRAWN BY	MAP
CHECKED BY	PGF
DRAWING NAME	EX. WWL EX. LINE 'A'.DWG
NO.	
DESCRIPTION	
BY	
REVISIONS	

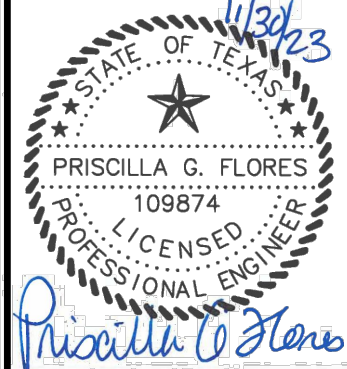

**LJA Engineering, Inc.**  
 9830 Colonnade Blvd  
 Suite 300  
 San Antonio, Texas 78230  
 Phone 210.503.2700  
 LJA.COM  
 TBPE No. F-1386

JOB NUMBER: SA3856.0402

SHEET NO. 53

OF 71 SHEETS

FOR PERMIT











**NOTES:**

- CONTRACTOR TO FIELD VERIFY EXACT LOCATION OF ALL EXISTING UTILITIES HORIZONTALLY AND VERTICALLY PRIOR TO CONSTRUCTION.
- MANDREL TESTING WILL BE REQUIRED ON ALL FLEXIBLE GRAVITY WASTEWATER PIPE AS PRE TCEQ RULES.
- ALL GRAVITY WASTEWATER LINES SHALL BE SDR-26 WWL ASTM D3034 UNLESS OTHERWISE NOTED.
- CONTRACTOR TO FILL AND COMPACT TO 95% DENSITY IN FILL SECTIONS OVER WASTEWATER LINES. 2.0'(MIN.) COVER OVER WATER PRIOR TO CONSTRUCTION.
- ALL SERVICES SHALL TERMINATE WITH A 2-WAY CLEANOUT.
- ALL ON-SITE UTILITIES SHALL BE LOCATED UNDERGROUND UNLESS REQUIRED BY THE UTILITY TO BE OTHERWISE LOCATED (SECTION 25-2-1.125).
- WHERE THE MINIMUM 9 FOOT SEPARATION DISTANCE BETWEEN WASTEWATER LINES AND WATER LINES / MAINS CANNOT BE MAINTAINED, THE INSTALLATION OF WASTEWATER LINES SHALL BE IN STRICT ACCORDANCE WITH TCEQ. THE WASTEWATER LINE SHALL BE CONSTRUCTED OF CAST IRON, DUCTILE IRON OR PVC MEETING THE ASTM SPECIFICATION FOR BOTH PIPES AND JOINTS OF 150 PSI AND SHALL BE IN ACCORDANCE WITH 30 TAC § 217.53 (D) (3) (A) (I).

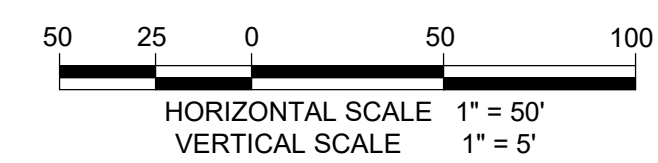

**LEGEND**

PROPOSED	EXISTING	DESCRIPTION
		SANITARY SEWER MANHOLE
		SANITARY SEWER LINE
		WATER LINE
		SANITARY SEWER LATERAL
		CLEAN OUT (INSTALL BY HOME BUILDER)
		WATER VALVE
		SINGLE WATER SERVICE
		DUAL WATER SERVICE
		FIRE HYDRANT
		PROPOSED SIDEWALK BY DEVELOPER
		WATER METER
		GAS VALVE
		GAS LINE
		STORM SEWER MANHOLE
		CURB INLET
		POWER POLE
		STREET LIGHT (100 WATT LED)
		STREET LIGHT (250 WATT LED)
		GUY WIRE
		OVERHEAD ELECTRIC
		BENCHMARK
		TOP OF MANHOLE
		EXISTING
		UTILITY EASEMENT
		EASEMENT
		VOLUME
		PAGE
		UTILITY X-ING

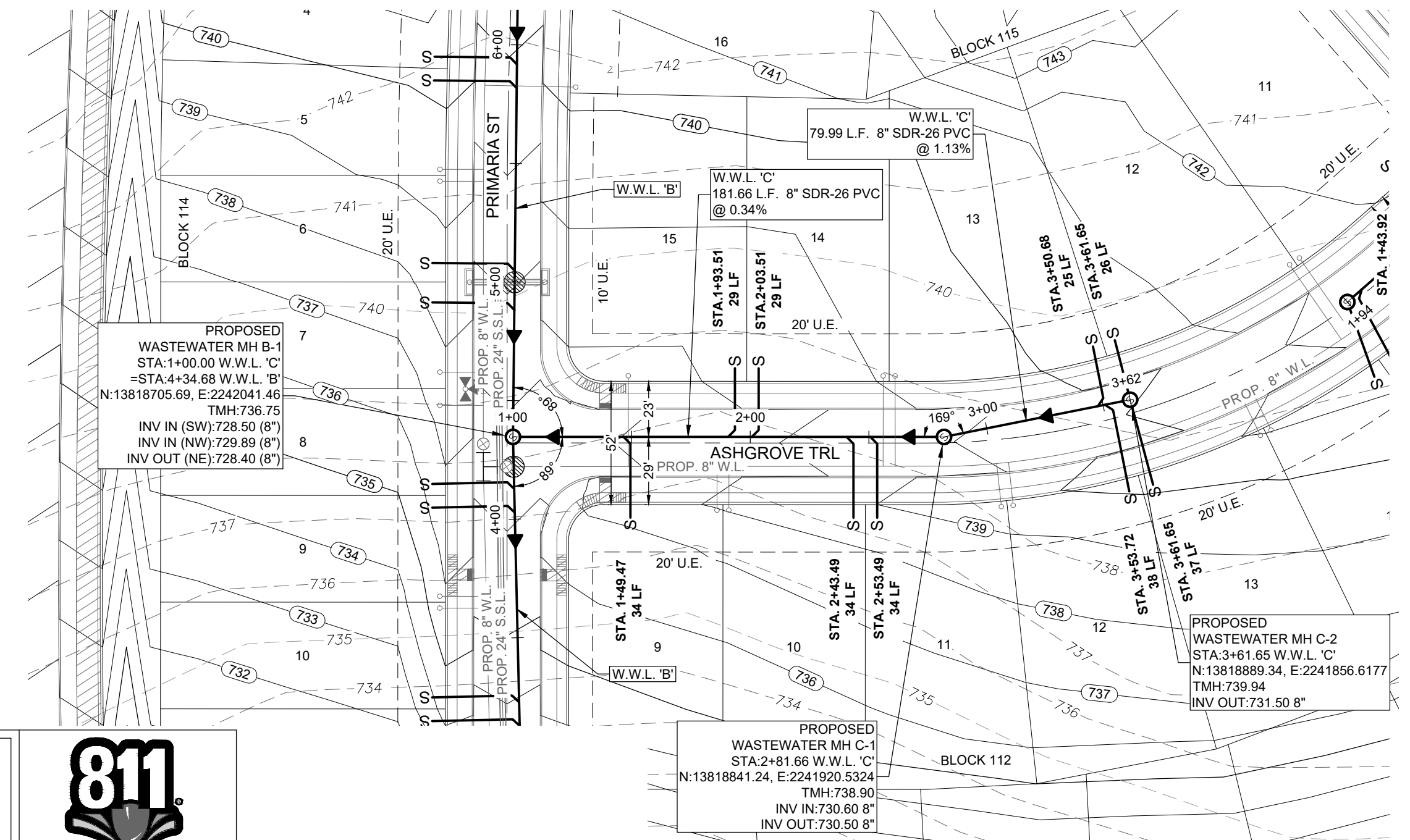

WASTEWATER LINE 'C' STA. 1+00.00 TO END

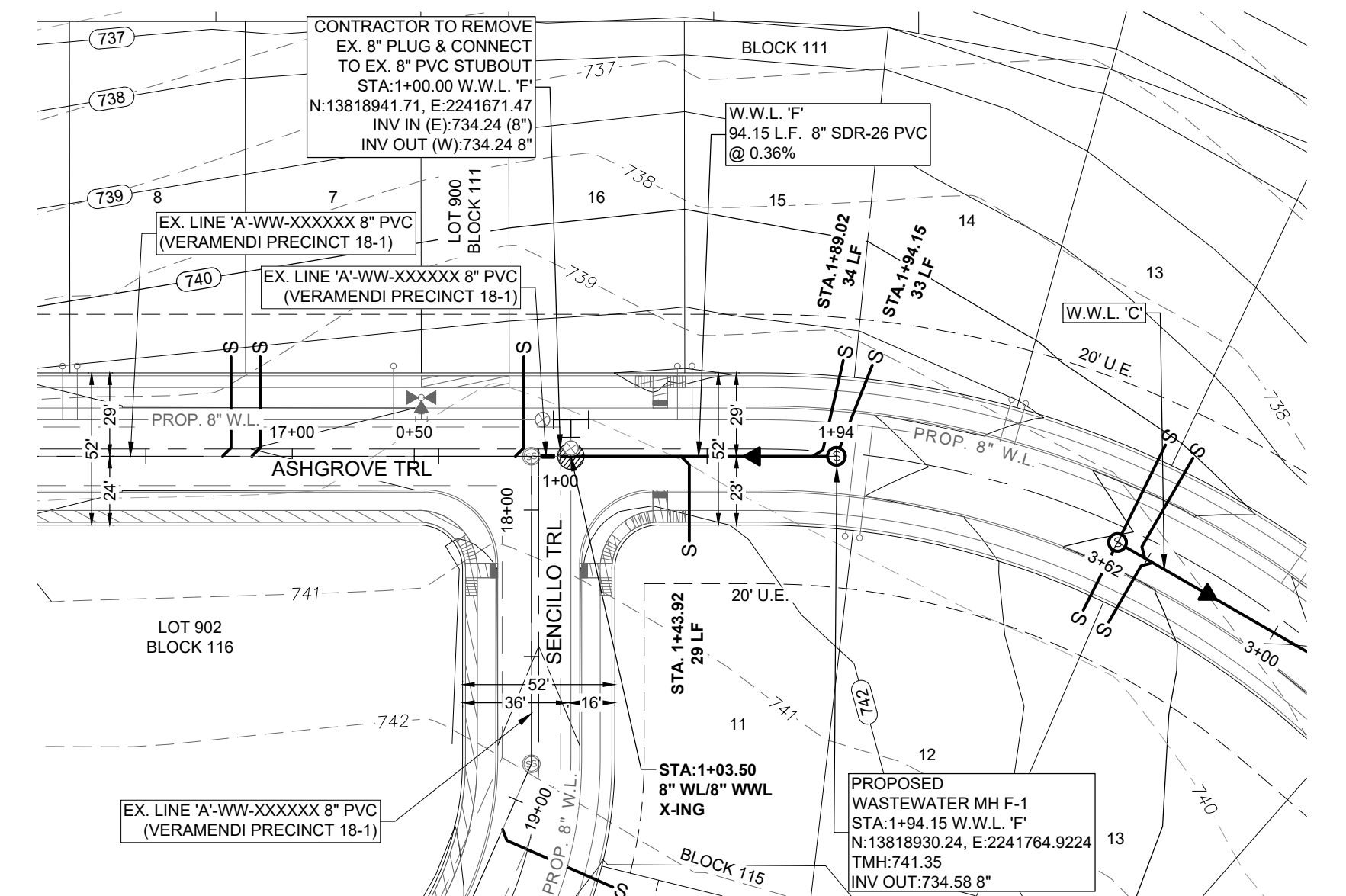

WASTEWATER LINE 'F' STA. 1+00.00 TO END

**CAUTION:** CONTRACTOR TO NOTIFY TEXAS ONE CALL AT 1-800-245-4545 48 HOURS PRIOR TO CONSTRUCTION FOR UTILITY LINE LOCATE. CONTRACTOR SHALL VERIFY HORIZONTAL AND VERTICAL LOCATION OF ALL EXISTING UTILITIES PRIOR TO CONSTRUCTION. ENGINEER SHALL BE NOTIFIED IMMEDIATELY OF ANY SIGNIFICANT DISCREPANCIES OR REQUIRED DESIGN CHANGES. EXISTING UTILITIES SHOWN HEREON ARE FOR INFORMATIONAL PURPOSES ONLY. ENGINEER ASSUMES NO RESPONSIBILITY FOR THE ACCURACY OF THIS INFORMATION.

**TRENCH EXCAVATION SAFETY PROTECTION**  
 CONTRACTOR AND/OR CONTRACTOR'S INDEPENDENTLY RETAINED EMPLOYEE OR STRUCTURAL DESIGNER/GEOTECHNICAL SAFETY/EQUIPMENT CONSULTANT, IF ANY, SHALL REVIEW THESE PLANS AND AVAILABLE GEOTECHNICAL INFORMATION AND THE ANTICIPATED INSTALLATION SITE(S) WITHIN THE PROJECT WORK AREA IN ORDER TO IMPLEMENT CONTRACTOR'S TRENCH EXCAVATION SAFETY PROTECTION SYSTEMS, PROGRAMS AND/OR PROCEDURES. THE CONTRACTOR'S IMPLEMENTATION OF THE SYSTEMS, PROGRAMS AND/OR PROCEDURES SHALL PROVIDE FOR ADEQUATE TRENCH EXCAVATION, SAFETY PROTECTION THAT COMPLIES WITH AS A MINIMUM, OSHA STANDARDS FOR TRENCH EXCAVATIONS. SPECIFICALLY, CONTRACTOR AND/OR CONTRACTOR'S INDEPENDENTLY RETAINED EMPLOYEE OR SAFETY CONSULTANT SHALL IMPLEMENT A TRENCH SAFETY PROGRAM IN ACCORDANCE WITH OSHA STANDARDS GOVERNING THE PRESENCE AND ACTIVITIES OF INDIVIDUALS WORKING IN AND AROUND TRENCH EXCAVATION.

LOCATION OF EXISTING UNDERGROUND AND OVERHEAD UTILITIES ARE APPROXIMATE LOCATIONS ONLY. THE CONTRACTOR SHALL DETERMINE THE EXACT LOCATION OF ALL EXISTING UTILITIES PRIOR TO BEGINNING WORK AND SHALL BE FULLY RESPONSIBLE FOR ANY AND ALL DAMAGES WHICH MIGHT OCCUR.



STATION	DESCRIPTION	INVERT	OUTLET	DIAMETER	LENGTH	GRADE
736.75	PROPOSED WASTEWATER MH B-1	728.50	728.40	8"	79.99 L.F.	0.34%
737.08	PROPOSED WASTEWATER MH C-1	730.60	730.50	8"	181.66 L.F.	0.34%
737.78	PROPOSED WASTEWATER MH C-2	731.50	731.40	8"	79.99 L.F.	1.13%

STATION	DESCRIPTION	INVERT	OUTLET	DIAMETER	LENGTH	GRADE
741.48	PROPOSED WASTEWATER EX. PLUG	734.24	734.24	8"	94.15 L.F.	0.36%
741.54	PROPOSED WASTEWATER MH F-1	734.58	734.57	8"	94.15 L.F.	0.36%

VERAMENDI PRECINCT 18 UNIT 2  
 WASTEWATER LINE 'C' & 'F' PLAN & PROFILE  
 STA. 1+00.00 TO END

NO.	DATE	DESCRIPTION

11/03/2023  
 DATE: 11/03/2023  
 DESIGNED BY: NG  
 DRAWN BY: MAP  
 CHECKED BY: PGF  
 DRAWING NAME: W.W.L. 'C' P&P.dwg

**LJA Engineering, Inc.**  
 9830 Calomnade Blvd  
 Suite 300  
 San Antonio, Texas 78230  
 Phone 210.503.2700  
 LJA.COM  
 TBPE No. F-1386

JOB NUMBER: SA3856.0402  
 SHEET NO. **58**  
 OF 71 SHEETS

K:\QA\BQA\ACA Properties\0402 Veramendi Precinct 18-2\1408 Site Development\Plan\W.W.L.'C' P&P.dwg  
 Last Modified: Nov 03, 2023 10:16:37  
 Plot Date: 11/03/2023 10:16:37





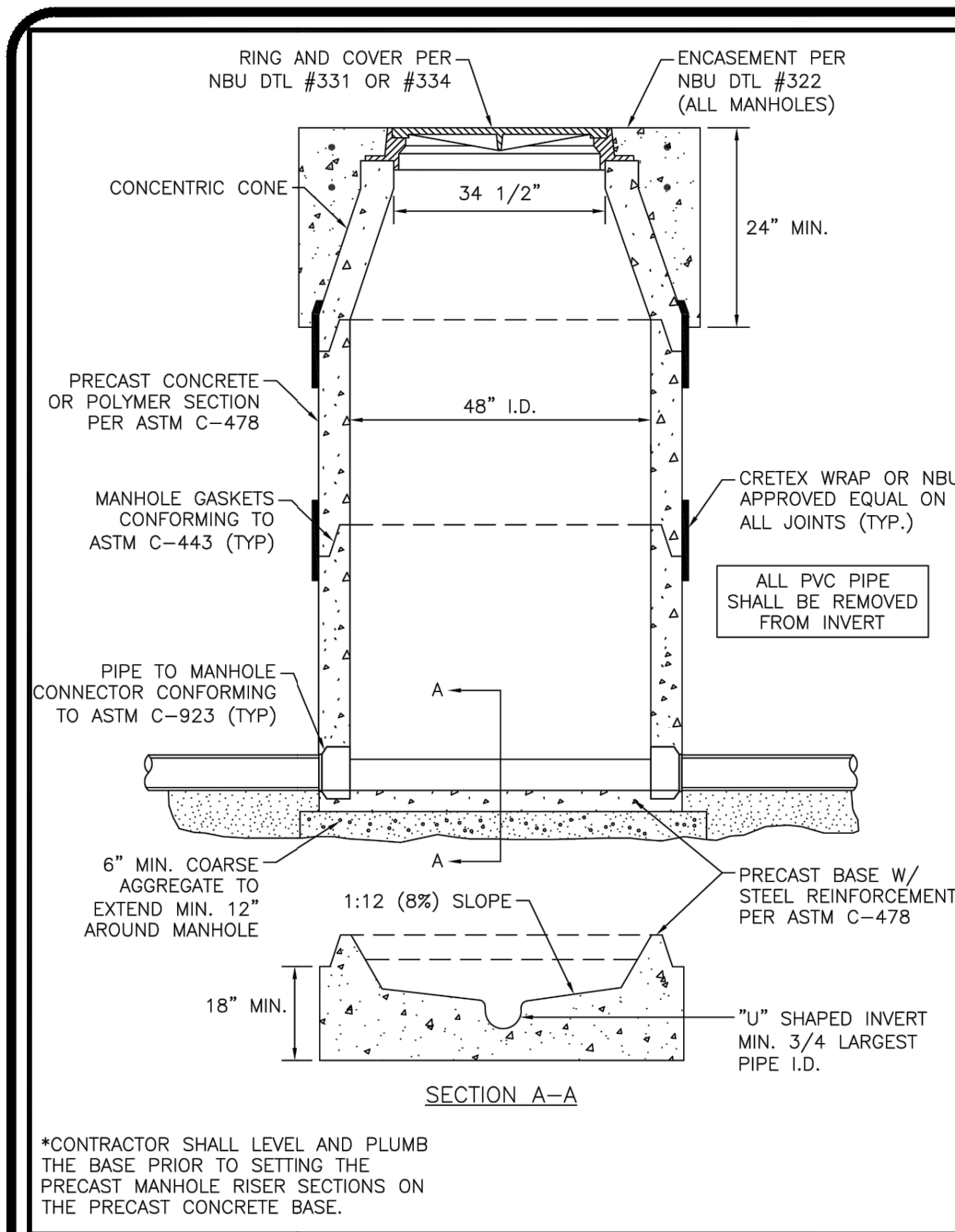

<b>NBU</b>	DESIGNED BY: A. Willard	STANDARD DRAWING	<b>WASTEWATER MANHOLE ON PRECAST BASE</b>	
NEW BRAUNFELS UTILITIES WATER SYSTEMS ENGINEERING	DATE: 08/17/21	SCALE: N.T.S.	SHEET: 1 OF 1	FIGURE NO: 328

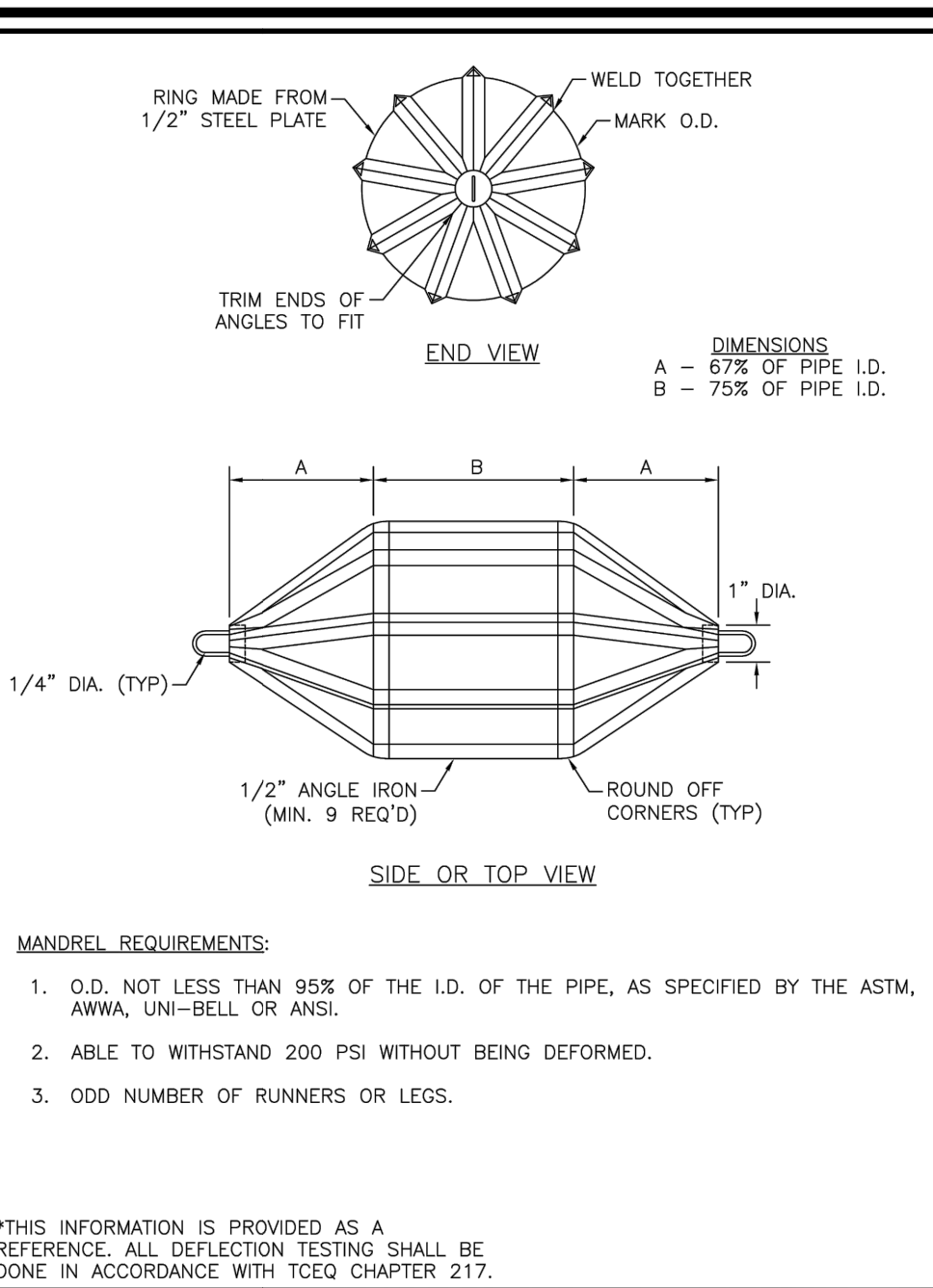

<b>NBU</b>	DESIGNED BY: A. Willard	STANDARD DRAWING	<b>GO, NO GO DEFLECTION TESTING MANDREL</b>	
NEW BRAUNFELS UTILITIES WATER SYSTEMS ENGINEERING	DATE: 08/17/21	SCALE: N.T.S.	SHEET: 1 OF 1	FIGURE NO: 330

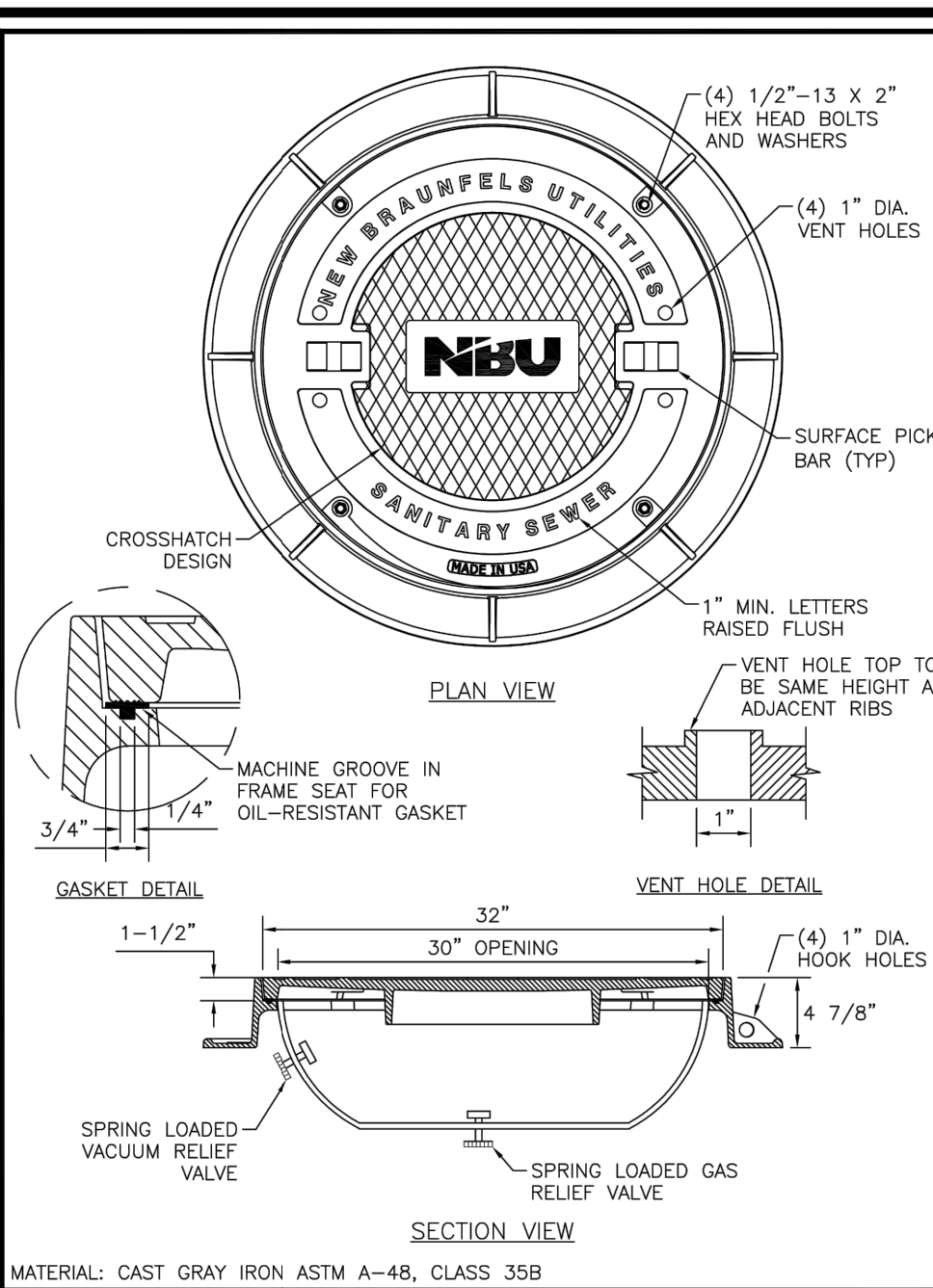

<b>NBU</b>	DESIGNED BY: A. Willard	STANDARD DRAWING	<b>VENTED SANITARY SEWER MANHOLE COVER</b>	
NEW BRAUNFELS UTILITIES WATER SYSTEMS ENGINEERING	DATE: 08/17/21	SCALE: N.T.S.	SHEET: 1 OF 1	FIGURE NO: 334

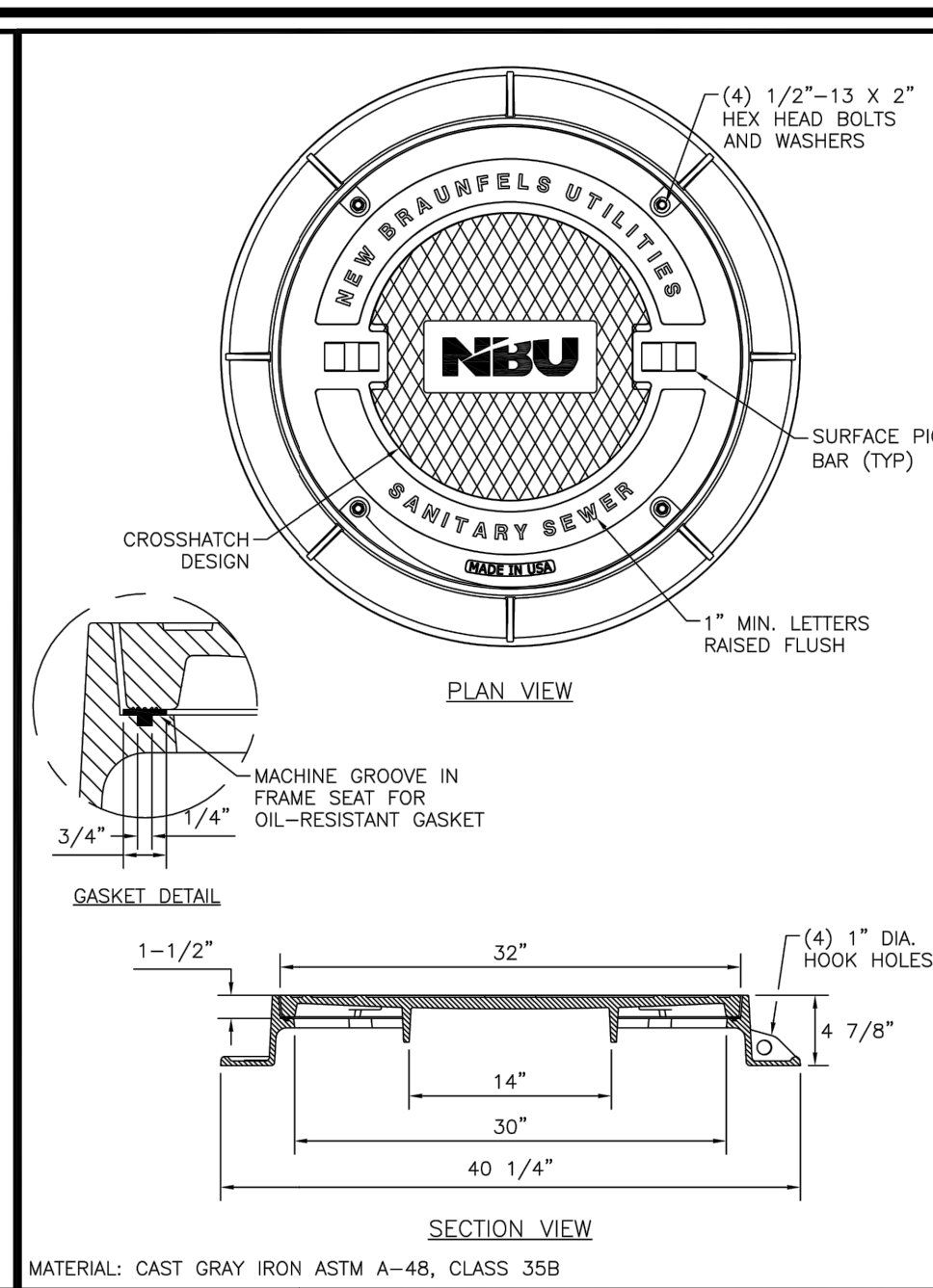

<b>NBU</b>	DESIGNED BY: A. Willard	STANDARD DRAWING	<b>SANITARY SEWER MANHOLE COVER</b>	
NEW BRAUNFELS UTILITIES WATER SYSTEMS ENGINEERING	DATE: 08/17/21	SCALE: N.T.S.	SHEET: 1 OF 1	FIGURE NO: 331

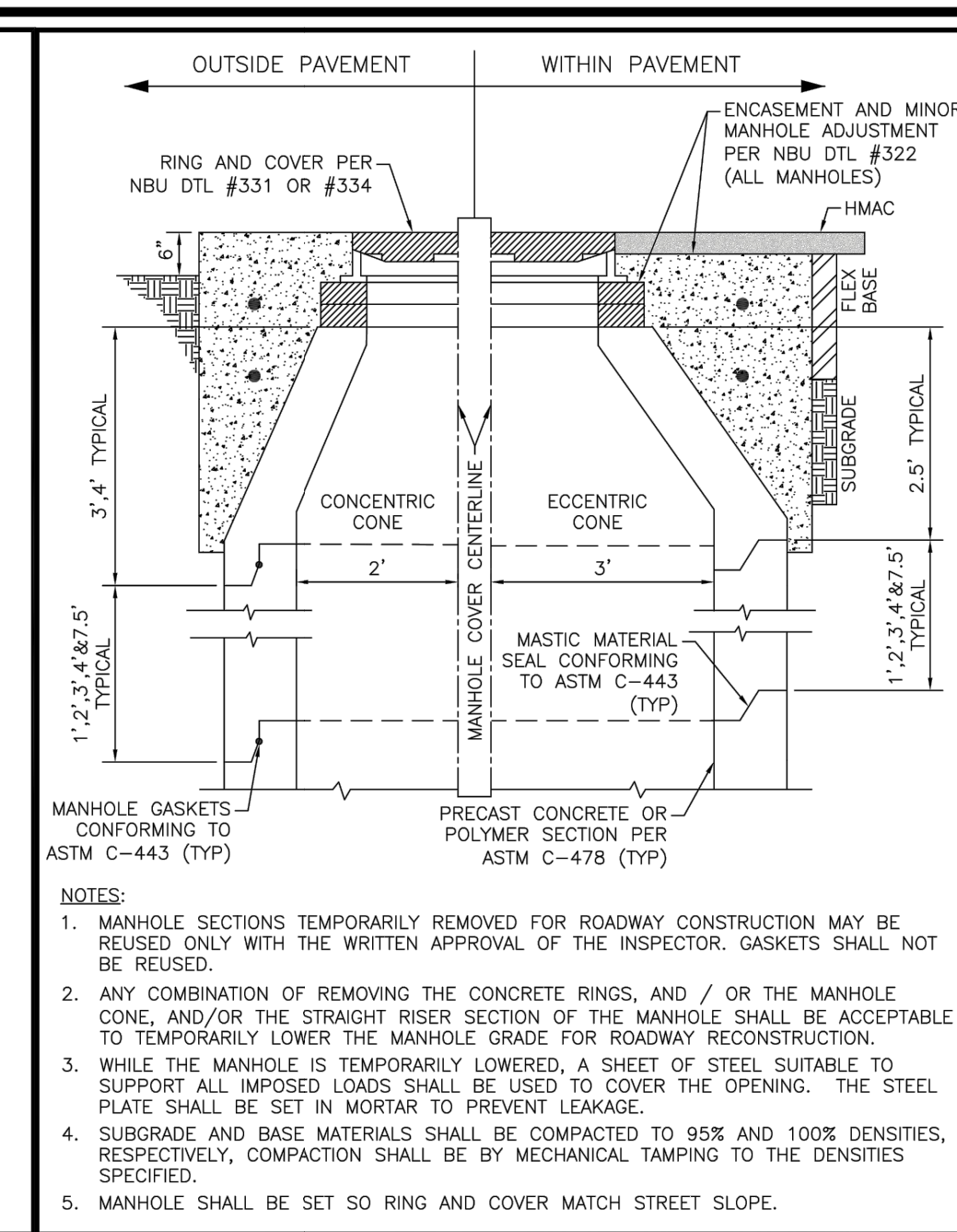

<b>NBU</b>	DESIGNED BY: A. Willard	STANDARD DRAWING	<b>MAJOR MANHOLE ADJUSTMENT</b>	
NEW BRAUNFELS UTILITIES WATER SYSTEMS ENGINEERING	DATE: 08/17/21	SCALE: N.T.S.	SHEET: 1 OF 1	FIGURE NO: 321

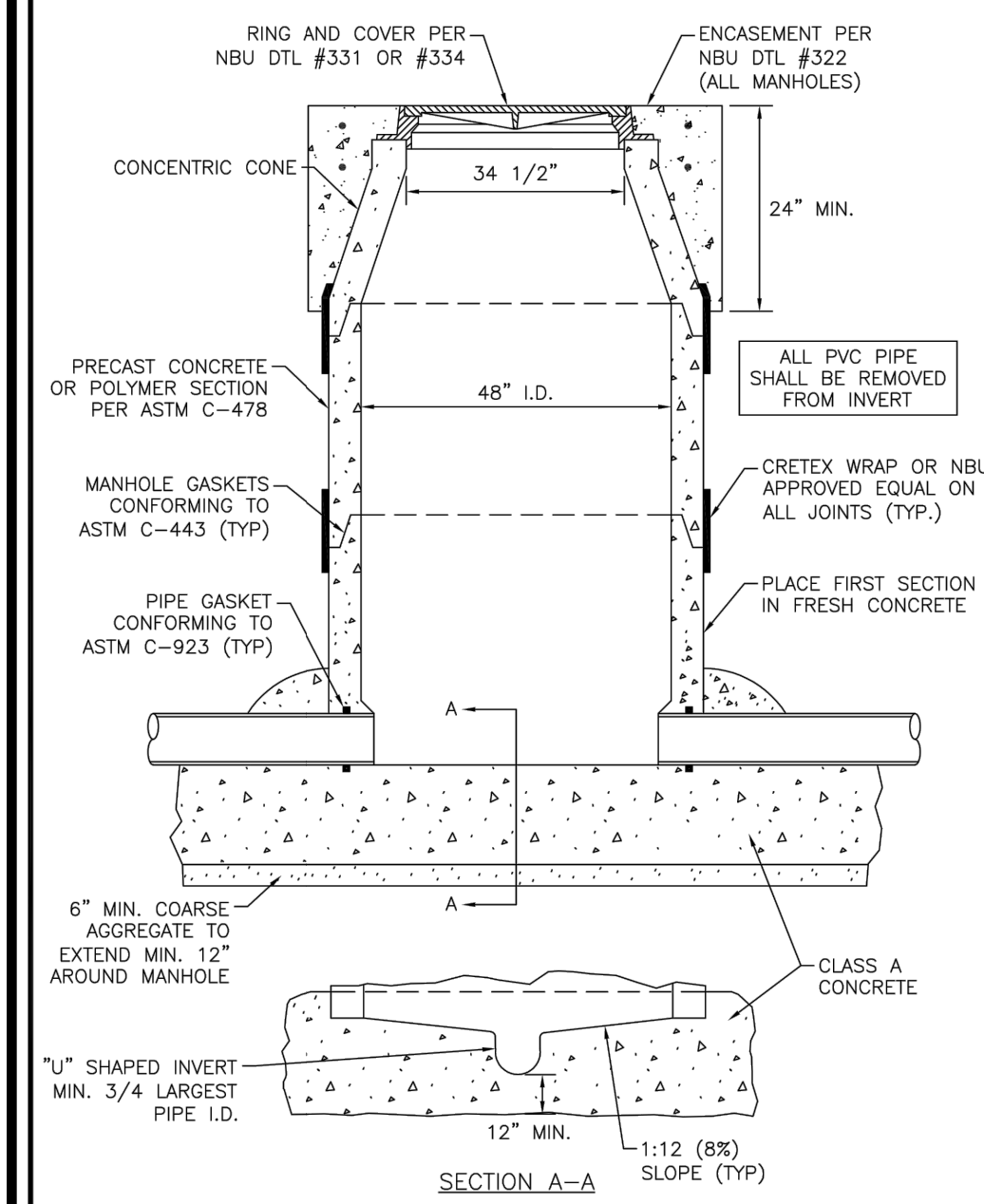

<b>NBU</b>	DESIGNED BY: A. Willard	STANDARD DRAWING	<b>WASTEWATER MANHOLE ON CAST IN PLACE FOUNDATION</b>	
NEW BRAUNFELS UTILITIES WATER SYSTEMS ENGINEERING	DATE: 08/17/21	SCALE: N.T.S.	SHEET: 1 OF 1	FIGURE NO: 327

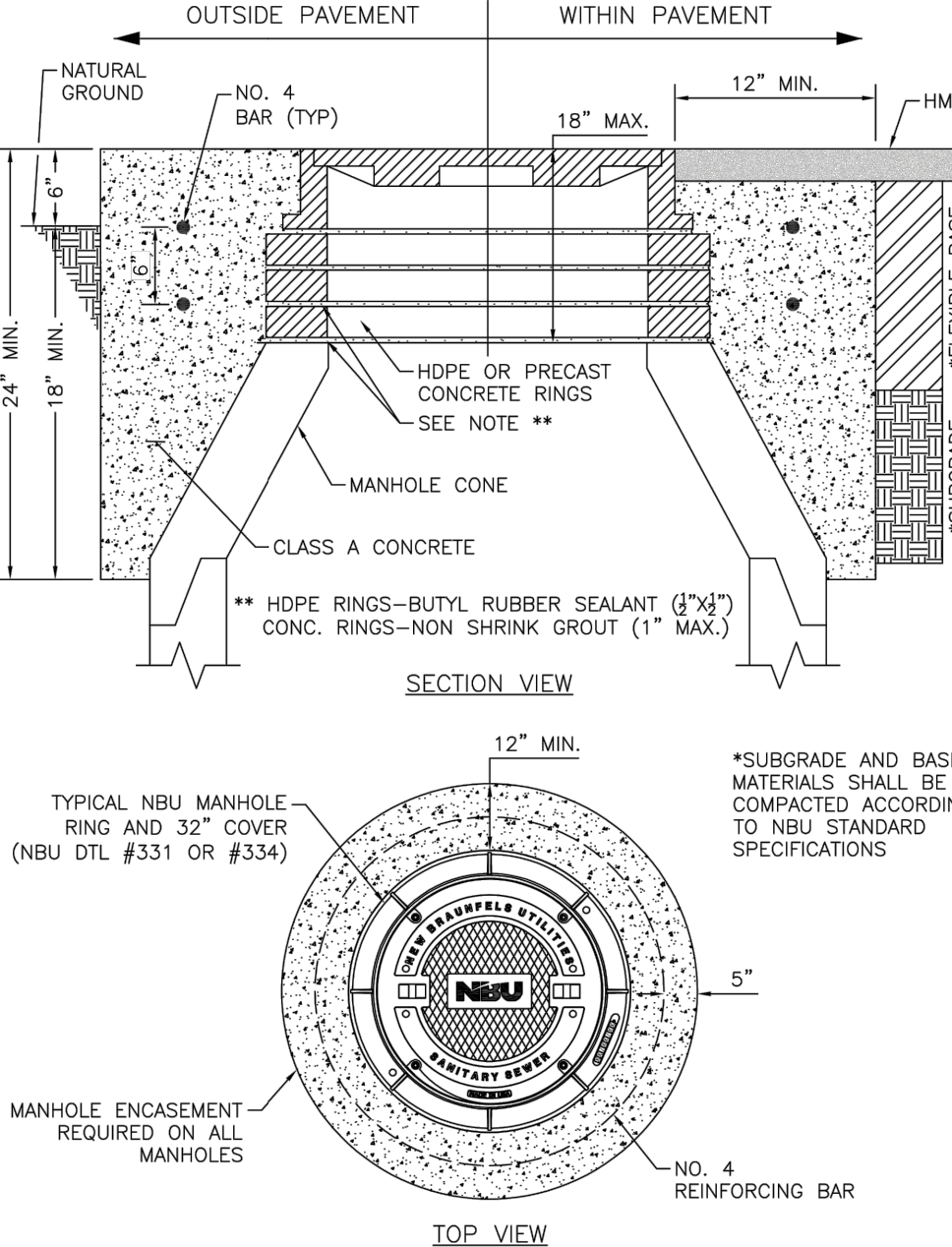

<b>NBU</b>	DESIGNED BY: A. Willard	STANDARD DRAWING	<b>NEW MANHOLE CONSTRUCTION AND MINOR MANHOLE ADJUSTMENT</b>	
NEW BRAUNFELS UTILITIES WATER SYSTEMS ENGINEERING	DATE: 08/17/21	SCALE: N.T.S.	SHEET: 1 OF 1	FIGURE NO: 322

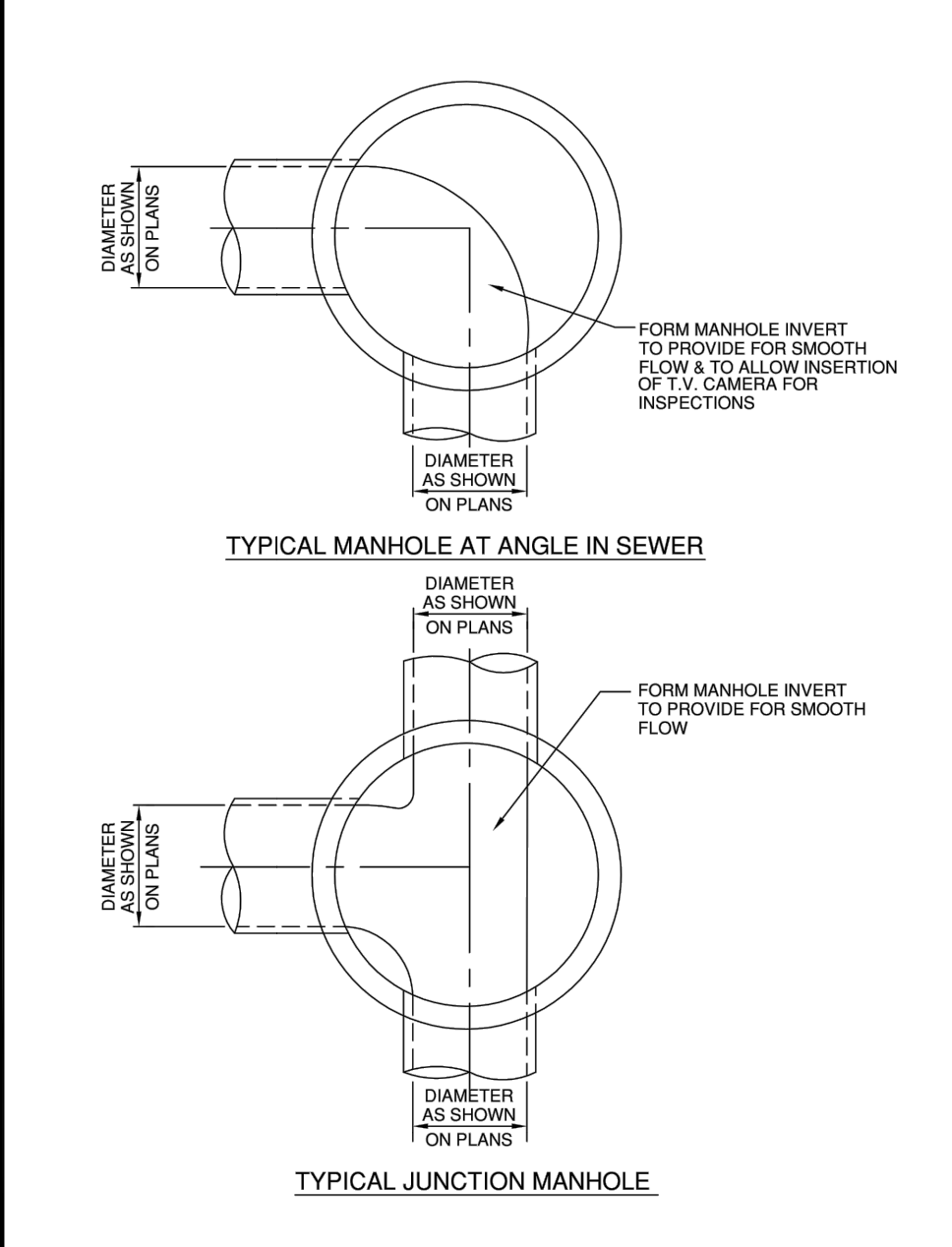

<b>NBU</b>	DESIGNED BY: J.D. Amaro	STANDARD DRAWING	<b>MANHOLE INVERT PLAN</b>	
NEW BRAUNFELS UTILITIES WATER SYSTEMS ENGINEERING	DATE: 04/16/03	SCALE: N.T.S.	SHEET: 1 OF 2	FIGURE NO: 320

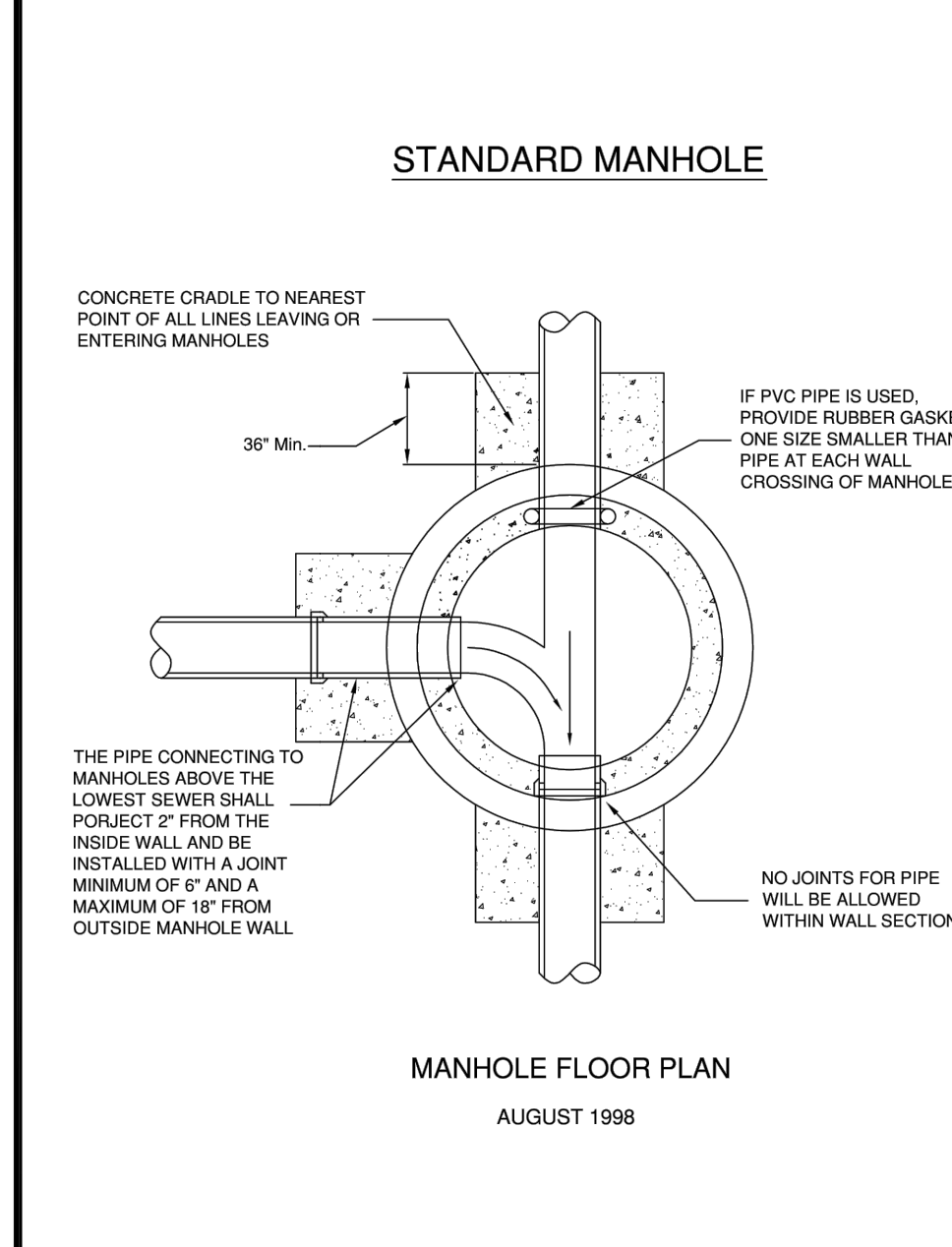

<b>NBU</b>	DESIGNED BY: H. Shadlock	STANDARD DRAWING	<b>STANDARD MANHOLE MANHOLE FLOOR PLAN</b>	
NEW BRAUNFELS UTILITIES WATER SYSTEMS ENGINEERING	DATE: 05/02/00	SCALE: N.T.S.	SHEET: 2 OF 2	FIGURE NO: 320

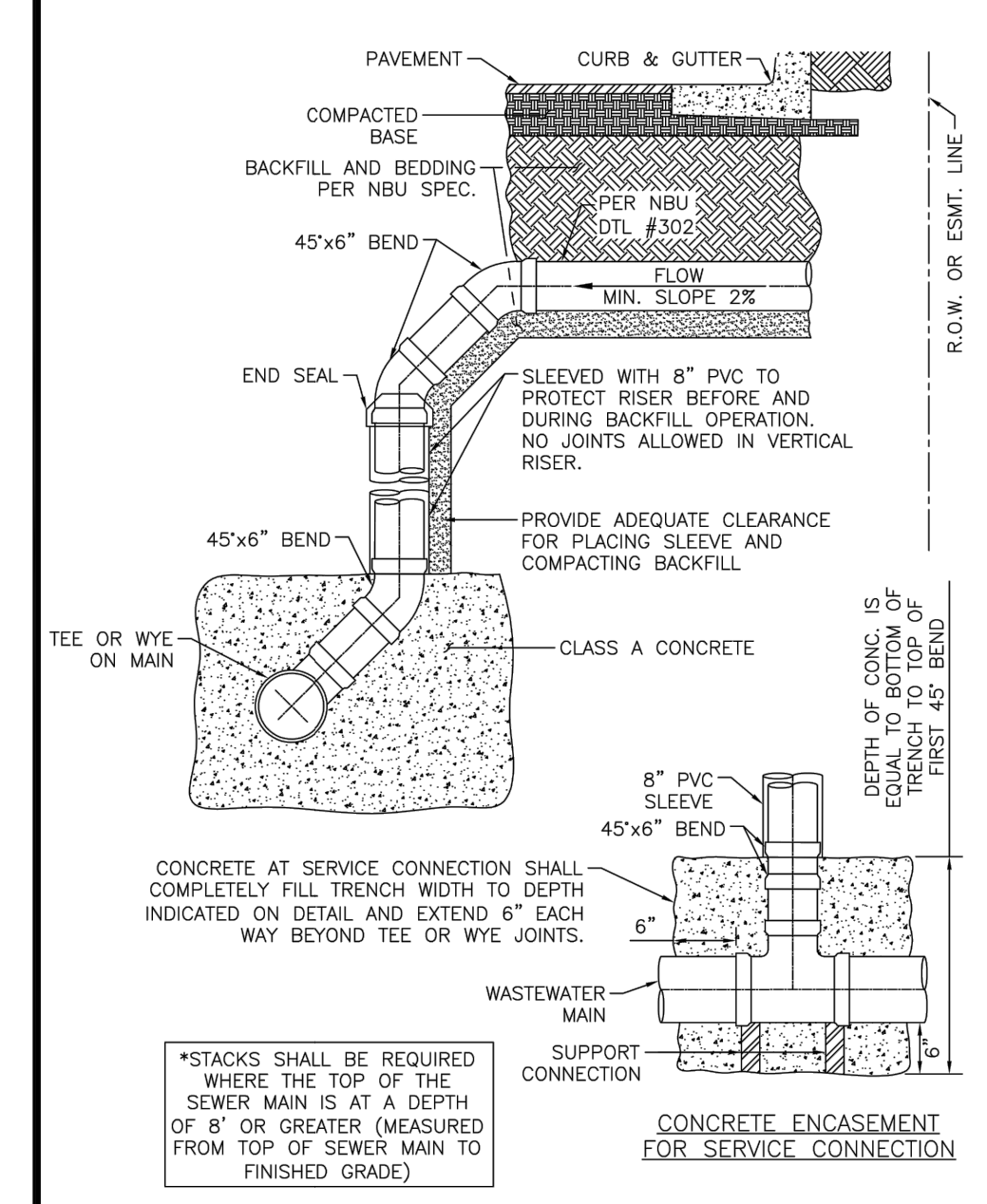

<b>NBU</b>	DESIGNED BY: A. Willard	STANDARD DRAWING	<b>WASTEWATER DEEP SERVICE CONNECTION DETAIL</b>	
NEW BRAUNFELS UTILITIES WATER SYSTEMS ENGINEERING	DATE: 08/17/21	SCALE: N.T.S.	SHEET: 1 OF 1	FIGURE NO: 301

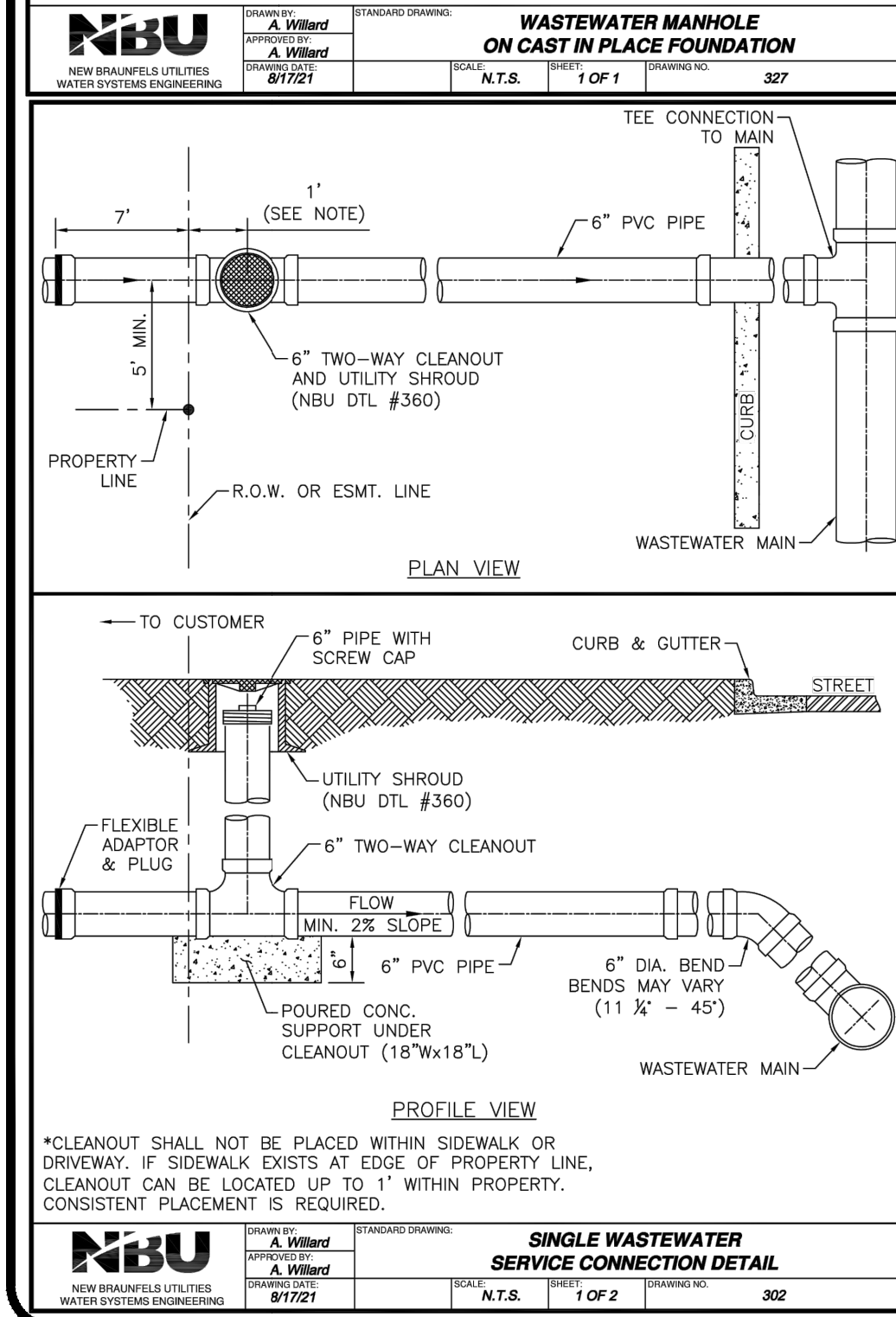

<b>NBU</b>	DESIGNED BY: A. Willard	STANDARD DRAWING	<b>SINGLE WASTEWATER SERVICE CONNECTION DETAIL</b>	
NEW BRAUNFELS UTILITIES WATER SYSTEMS ENGINEERING	DATE: 08/17/21	SCALE: N.T.S.	SHEET: 1 OF 2	FIGURE NO: 302

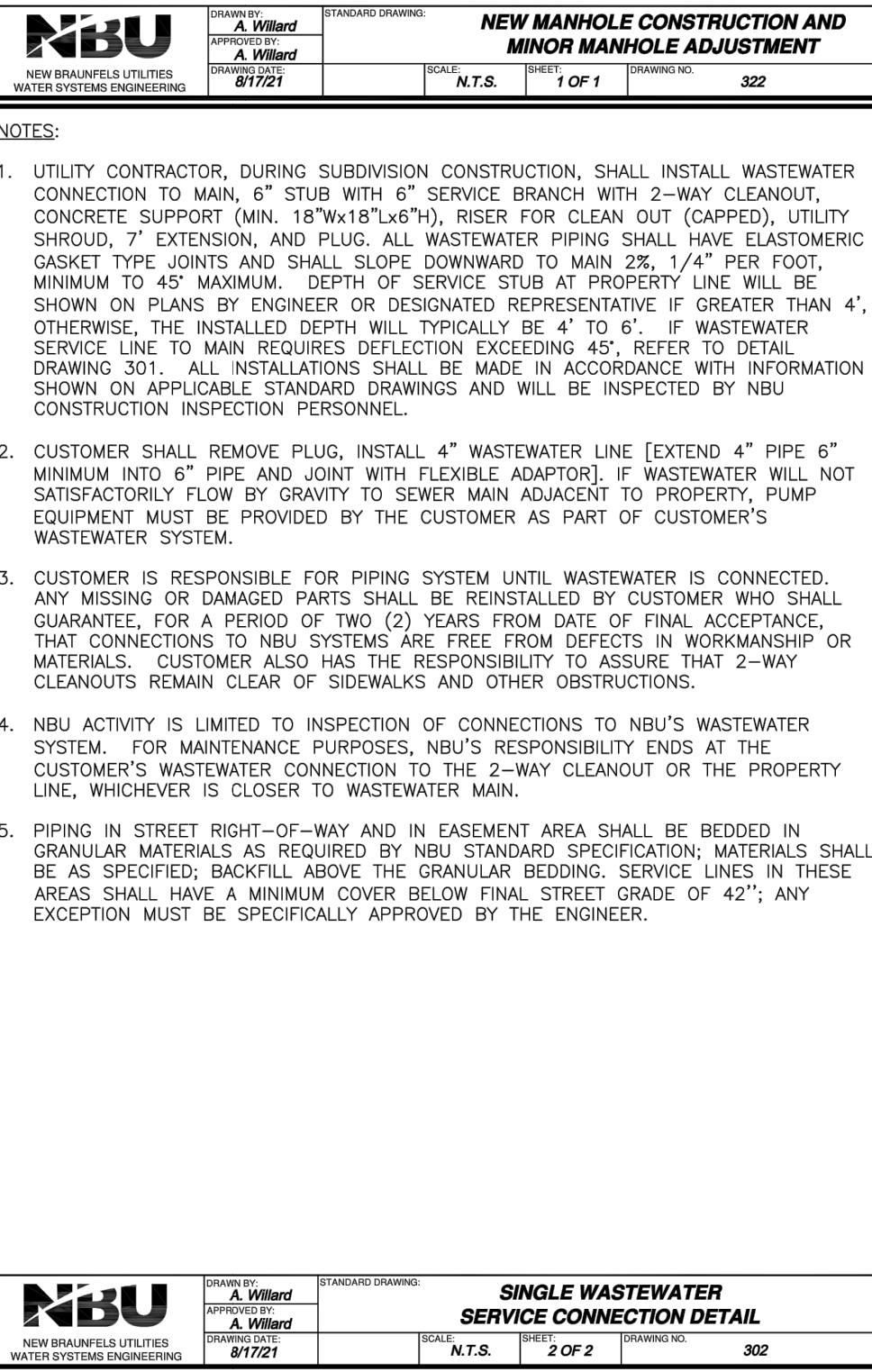

<b>NBU</b>	DESIGNED BY: A. Willard	STANDARD DRAWING	<b>SINGLE WASTEWATER SERVICE CONNECTION DETAIL</b>	
NEW BRAUNFELS UTILITIES WATER SYSTEMS ENGINEERING	DATE: 08/17/21	SCALE: N.T.S.	SHEET: 2 OF 2	FIGURE NO: 302

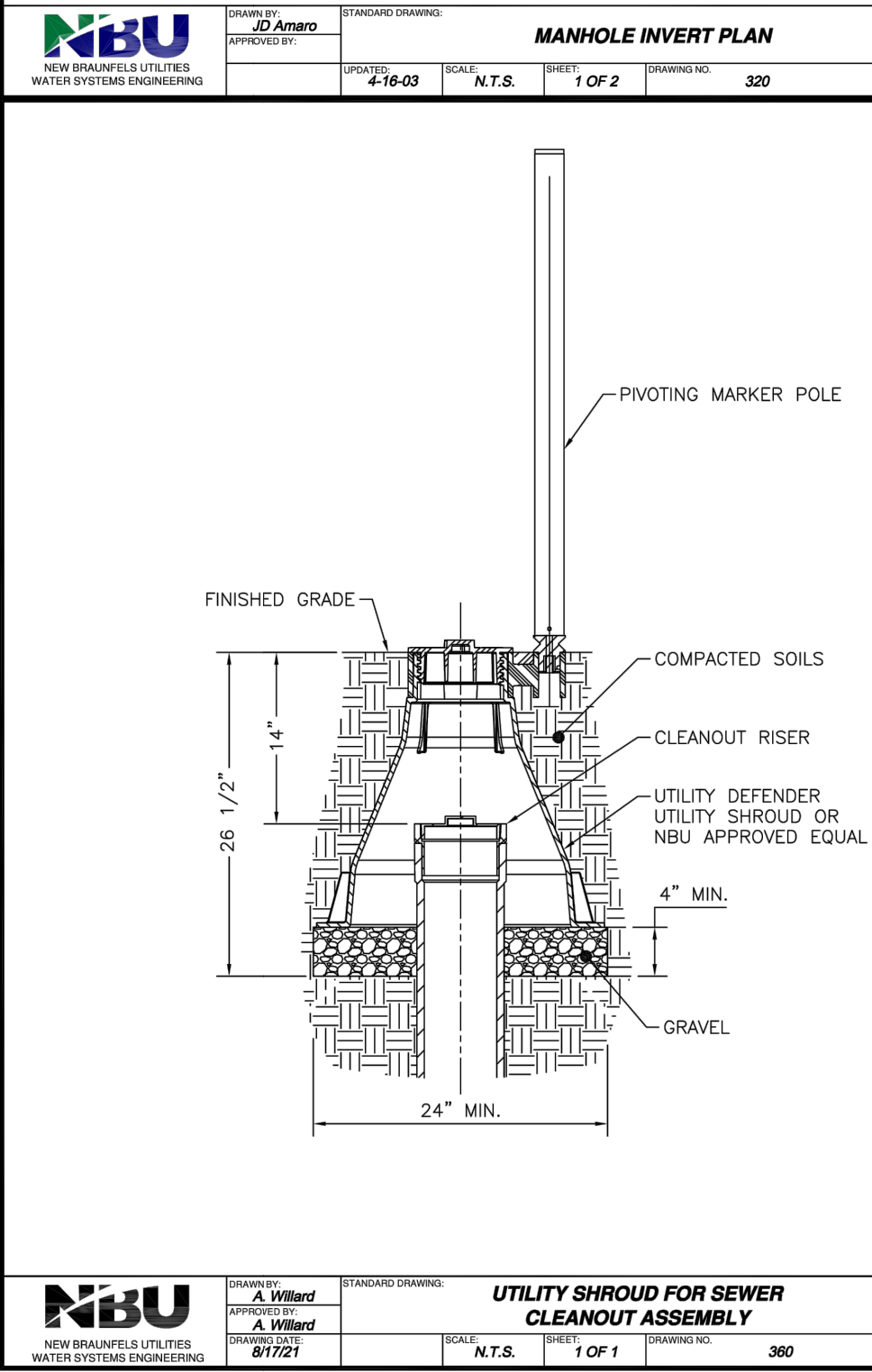

<b>NBU</b>	DESIGNED BY: A. Willard	STANDARD DRAWING	<b>UTILITY SHROUD FOR SEWER CLEANOUT ASSEMBLY</b>	
NEW BRAUNFELS UTILITIES WATER SYSTEMS ENGINEERING	DATE: 08/17/21	SCALE: N.T.S.	SHEET: 1 OF 1	FIGURE NO: 300

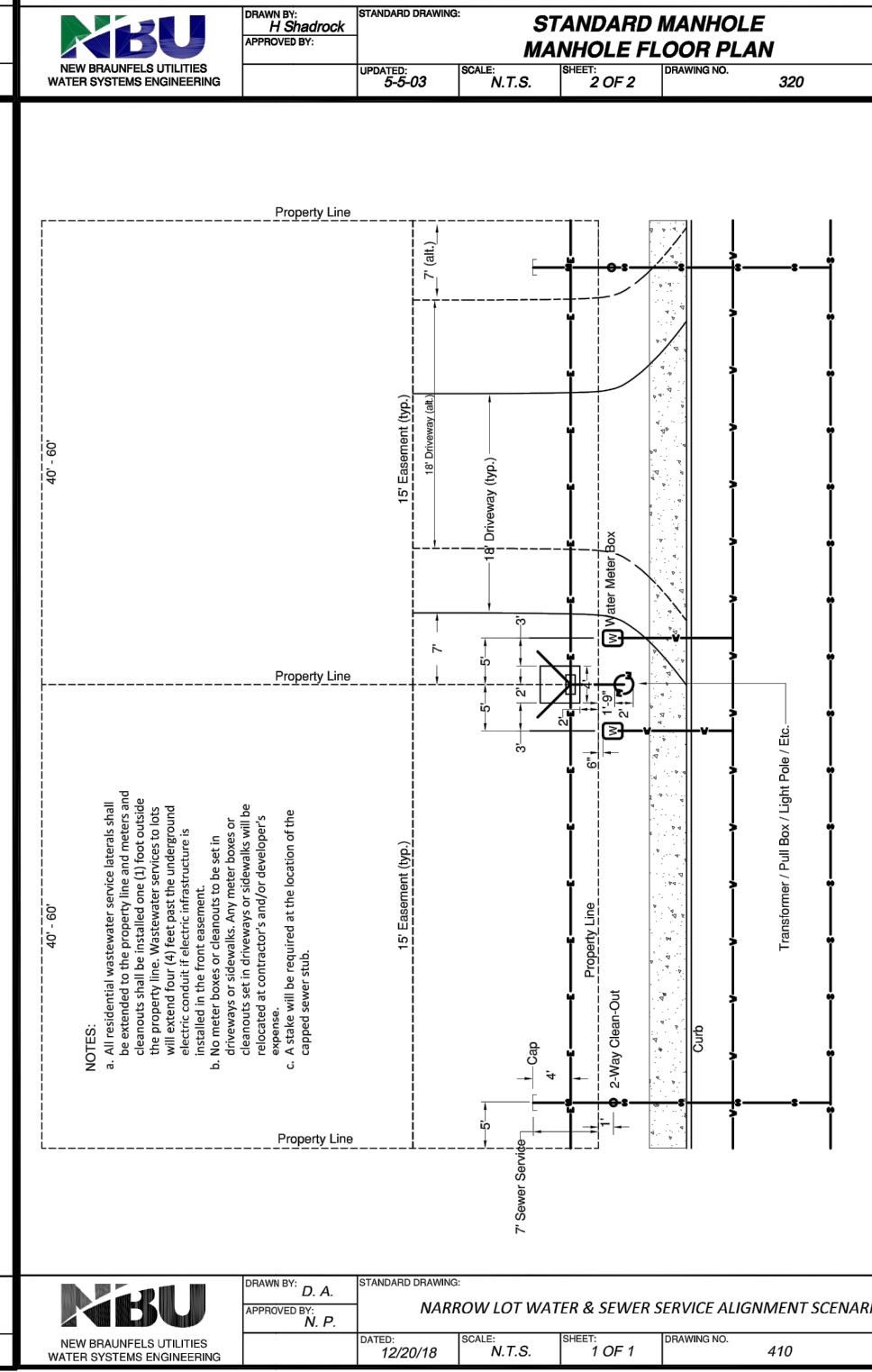

<b>NBU</b>	DESIGNED BY: D.A. PROFFER	STANDARD DRAWING	<b>NARROW LOT WATER &amp; SEWER SERVICE ALIGNMENT SCENARIO</b>	
NEW BRAUNFELS UTILITIES WATER SYSTEMS ENGINEERING	DATE: 12/20/18	SCALE: N.T.S.	SHEET: 1 OF 1	FIGURE NO: 410

**CITY OF NEW BRAUNFELS NOTES:**

- NO VALVES, HYDRANTS, ETC. SHALL BE CONSTRUCTED WITHIN CURBS, SIDEWALKS, OR DRIVEWAYS.
- ALL UTILITIES TO BE CONSTRUCTED PRIOR TO STREETS.
- THIS PROJECT INCLUDES UTILITY INSTALLATIONS GREATER THAN 6-FEET IN DEPTH. DEEP TRENCHES POSE COMPACTION TESTING AND CONSTRUCTION CHALLENGES AND CITY METHODS FOR TESTING AND COMPACTION MAY NOT BE ACHIEVABLE. A UTILITY COMPACTION PLAN WILL BE REQUIRED AND MUST BE SUBMITTED FOR APPROVAL TO CITY PRIOR TO UTILITY INSTALLATION.
- UTILITY TRENCH COMPACTION - ALL UTILITY TRENCH COMPACTION TESTS WITHIN THE STREET PAVEMENT/SIDEWALK SECTION SHALL BE THE RESPONSIBILITY OF THE DEVELOPER'S GEOTECHNICAL ENGINEER. FILL MATERIAL SHALL BE PLACED IN UNIFORM LAYERS NOT TO EXCEED TWELVE INCHES (12") LOOSE. DETERMINE THE MAXIMUM LIFT THICKNESS BASED ON THE ABILITY OF THE COMPACTING OPERATION AND EQUIPMENT USED TO MEET THE REQUIRED DENSITY. EACH LAYER OF MATERIAL SHALL BE COMPACTED TO A MINIMUM 95% DENSITY AND TESTED FOR DENSITY AND MOISTURE IN ACCORDANCE WITH TEST METHODS TEX-113-E, TEX-114-E, TEX-115-E. THE NUMBER AND LOCATION OF REQUIRED TESTS SHALL BE DETERMINED BY THE GEOTECHNICAL ENGINEER AND APPROVED BY THE CITY OF NEW BRAUNFELS STREET INSPECTOR AT A MINIMUM. TESTS SHALL BE TAKEN EVERY 200 LF FOR EACH LIFT AND EVERY OTHER SERVICE LINE. UPON COMPLETION OF TESTING THE GEOTECHNICAL ENGINEER SHALL PROVIDE THE CITY OF NEW BRAUNFELS STREET INSPECTOR WITH ALL TESTING DOCUMENTATION AND A CERTIFICATION STATING THAT THE PLACEMENT OF FILL MATERIAL HAS BEEN COMPLETED IN ACCORDANCE WITH THE PLANS. ADDITIONAL DENSITY TESTS MAY BE REQUIRED BY THE CITY OF NEW BRAUNFELS INSPECTOR.

**VERAMENDI PRECINCT 18 UNIT 2**

**WASTEWATER DETAILS (SHEET 1 OF 2)**

DATE	10/26/2023
DESIGNED BY	NG
DRAWN BY	TM
CHECKED BY	PF
DRAWING NAME	Wastewater Details.dwg

**PRISCILLA G. FLORES**  
109874  
LICENSED PROFESSIONAL ENGINEER

**LJA Engineering, Inc.**  
9830 Calomarde Blvd  
Suite 300  
San Antonio, Texas 78230  
Phone 210.503.2700  
LJA.COM  
TBP# No. F-1386

JOB NUMBER: SA3856.0402

SHEET NO. **61** OF 71 SHEETS

**Texas Commission on Environmental Quality  
Organized Sewage Collection System  
General Construction Notes**

**Edwards Aquifer Protection Program Construction Notes – Legal Disclaimer**

The following "construction notes" are intended to be advisory in nature only and do not constitute an approval or conditional approval by the Executive Director, nor do they constitute a comprehensive listing of rules or conditions to be followed during construction. Further actions may be required to achieve compliance with TCEQ regulations found in Title 30, Texas Administrative Code, Chapters 213 and 217, as well as local ordinances and regulations providing for the protection of water quality. Additionally, nothing contained in the following "construction notes" restricts the powers of the Executive Director, the commission or any other governmental entity to prevent, correct, or curtail activities that result or may result in pollution of the Edwards Aquifer or hydrologically connected surface waters. The holder of any Edwards Aquifer Protection Plan containing "construction notes" is still responsible for compliance with Title 30, Texas Administrative Code, Chapters 213 or any other applicable TCEQ regulation, as well as all conditions of an Edwards Aquifer Protection Plan through all phases of plan implementation. Failure to comply with any condition of the Executive Director's approval, whether or not in construction of any "construction notes," is a violation of TCEQ regulations and any violation is subject to administrative rules, orders, and penalties as provided under Title 30, Texas Administrative Code § 211.10 (relating to Enforcement). Such violations may also be subject to civil penalties and injunction. The following "construction notes" in no way represent an approved exception by the Executive Director to any part of Title 30 Texas Administrative Code, Chapters 213 and 217, or any other TCEQ applicable regulation.

- This Organized Sewage Collection System (SCS) must be constructed in accordance with 30 Texas Administrative Code (TAC) §213.5(c), the Texas Commission on Environmental Quality's (TCEQ) Edwards Aquifer Rules and any local government standard specifications.
- All contractors conducting regulated activities associated with this proposed regulated project must be provided with copies of the SCS plan and the TCEQ letter indicating the specific conditions of its approval. During the course of these regulated activities, the contractors must be required to keep on-site copies of the plan and the approval letter.
- A written notice of construction must be submitted to the presiding TCEQ regional office at least 48 hours prior to the start of any regulated activities. This notice must include:
  - the name of the approved project;
  - the activity start date; and
  - the contact information of the prime contractor.
- Any modification to the activities described in the referenced SCS application following the date of approval may require the submitter of the SCS application to immediately modify the application, including the payment of appropriate fees and all information necessary for its review and approval.
- Prior to beginning any construction activity, all temporary erosion and sedimentation (E&S) control measures must be properly installed and maintained in accordance with the manufacturers specifications. These controls must remain in place until the disturbed areas have been permanently stabilized.
- If any sensitive features are discovered during the wastewater line trenching activities, all regulated activities near the sensitive feature must be suspended immediately. The applicant must immediately notify the appropriate regional office of the TCEQ of the feature discovered. A geologist's assessment of the location and extent of the feature discovered must be reported to that regional office in writing and the applicant must submit a plan for ensuring the structural integrity of the sewer line or for modifying the proposed collection system alignment around the feature. The regulated activities near the sensitive feature may not proceed until the

If no stub-out is present an alternate method of joining laterals is shown in the detail on Plan Sheet \_\_\_ of \_\_\_. (For potential future laterals).

The private service lateral stub-outs must be installed as shown on the plan and profile sheets on Plan Sheet \_\_\_ of \_\_\_, and marked after backfilling as shown in the detail on Plan Sheet \_\_\_ of \_\_\_.

- Trenching, bedding and backfill must conform with 30 TAC §217.54. The bedding and backfill for flexible pipe must comply with the standards of ASTM D-2321, Classes IA, IB, II or III. Rigid pipe bedding must comply with the requirements of ASTM C 12 (ANSI A 106.2) classes A, B or C.
- Sewer lines must be tested from manhole to manhole. When a new sewer line is connected to an existing stub or clean-out, it must be tested from existing manhole to new manhole. If a stub or clean-out is used at the end of the proposed sewer line, no private service attachments may be connected between the last manhole and the cleanout unless it can be certified as conforming with the provisions of 30 TAC §213.5(c)(3)(E).
- All sewer lines must be tested in accordance with 30 TAC §217.57. The engineer must retain copies of all test results which must be made available to the executive director upon request. The engineer must certify in writing that all wastewater lines have passed all required testing to the appropriate regional office within 30 days of test completion and prior to use of the new collection system. Testing method will be:
  - For a collection system pipe that will transport wastewater by gravity flow, the design must specify an infiltration and exfiltration test or a low-pressure air test. A test must conform to the following requirements:
    - Low Pressure Air Test.**
      - A low pressure air test must follow the procedures described in American Society For Testing And Materials (ASTM) C-828, ASTM C-924, or ASTM F-1417 or other procedure approved by the executive director, except as to testing times as required in Table C.3 in subparagraph (C) of this paragraph or Equation C.3 in subparagraph (B)(ii) of this paragraph.
      - For sections of collection system pipe less than 36 inch average inside diameter, the following procedure must apply, unless a pipe is to be tested as required by paragraph (2) of this subsection.
        - A pipe must be pressurized to 3.5 pounds per square inch (psi) greater than the pressure exerted by groundwater above the pipe.
        - Once the pressure is stabilized, the minimum time allowable for the pressure to drop from 3.5 psi gauge to 2.5 psi gauge is computed from the following equation:

$$\text{Equation C.3} \quad T = \frac{0.085 \times D \times K}{Q}$$

Where:

- T = time for pressure to drop 1.0 pound per square inch gauge in seconds
- K = 0.00419 X D X L, but not less than 1.0
- D = average inside pipe diameter in inches

- L = length of line of same size being tested, in feet
- Q = rate of loss, 0.0015 cubic feet per minute per square foot internal surface
- (C) Since a K value of less than 1.0 may not be used, the minimum testing time for each pipe diameter is shown in the following Table C.3:

Pipe Diameter (inches)	Minimum Time (seconds)	Maximum Length for Minimum Time (feet)	Time for Longer Length (seconds/foot)
6	340	398	0.855
8	454	298	1.520
10	567	239	2.374
12	680	189	3.419
15	850	159	5.342
18	1020	133	7.693
21	1190	114	10.471
24	1360	100	13.676
27	1530	88	17.309
30	1700	80	21.369
33	1870	72	25.856

- An owner may stop a test if no pressure loss has occurred during the first 25% of the calculated testing time.
  - An owner shall use an infiltration test in lieu of an exfiltration test when pipes are installed below the groundwater level.
  - The total exfiltration, as determined by a hydrostatic head test, must not exceed 50 gallons per inch diameter per mile of pipe per 24 hours at a minimum test head of two feet above the crown of a pipe at an upstream manhole, or at least two feet above existing groundwater level, whichever is greater.
  - For construction within a 25-year flood plain, the infiltration or exfiltration must not exceed 10 gallons per inch diameter per mile of pipe per 24 hours at the same minimum test head as in subparagraph (C) of this paragraph.
  - If the quantity of infiltration or exfiltration exceeds the maximum quantity specified, an owner shall undertake remedial action in order to reduce
- Infiltration/Exfiltration Test.
    - The total exfiltration, as determined by a hydrostatic head test, must not exceed 50 gallons per inch of diameter per mile of pipe per 24 hours at a minimum test head of 2.0 feet above the crown of a pipe at an upstream manhole.
    - An owner shall use an infiltration test in lieu of an exfiltration test when pipes are installed below the groundwater level.
    - The total exfiltration, as determined by a hydrostatic head test, must not exceed 50 gallons per inch diameter per mile of pipe per 24 hours at a minimum test head of two feet above the crown of a pipe at an upstream manhole, or at least two feet above existing groundwater level, whichever is greater.
    - For construction within a 25-year flood plain, the infiltration or exfiltration must not exceed 10 gallons per inch diameter per mile of pipe per 24 hours at the same minimum test head as in subparagraph (C) of this paragraph.
    - If the quantity of infiltration or exfiltration exceeds the maximum quantity specified, an owner shall undertake remedial action in order to reduce

the infiltration or exfiltration to an amount within the limits specified. An owner shall retest a pipe following a remediation action.

- Mandrel Design.**
    - A rigid mandrel must be constructed of a metal or a rigid plastic material that can withstand 200 psi without being deformed.
    - A mandrel must have nine or more odd number of runners or legs.
    - A barrel section length must equal at least 75% of the inside diameter of a pipe.
    - Each size mandrel must use a separate proving ring.
  - Method Options.**
    - An adjustable or flexible mandrel is prohibited.
    - A test may not use television inspection as a substitute for a deflection test.
    - If requested, the executive director may approve the use of a deflectometer or a mandrel with removable legs or runners on a case-by-case basis.
- For a gravity collection system pipe with an inside diameter 27 inches and greater, other test methods may be used to determine vertical deflection. A deflection test method must be accurate to within plus or minus 0.2% deflection.
  - An owner shall not conduct a deflection test until at least 30 days after the final backfill.
  - Gravity collection system pipe deflection must not exceed five percent (5%).
  - If a pipe section fails a deflection test, an owner shall correct the problem and conduct a second test after the final backfill has been in place at least 30 days.

- All manholes must be tested to meet or exceed the requirements of 30 TAC §217.58.
  - All manholes must pass a leakage test.
  - An owner shall test each manhole (after assembly and backfilling) for leakage, separate and independent of the collection system pipes, by hydrostatic exfiltration testing, vacuum testing, or other method approved by the executive director.
    - Hydrostatic Testing.
      - The maximum leakage for hydrostatic testing or any alternative test methods is 0.025 gallons per foot diameter per foot of manhole depth per hour.
      - To perform a hydrostatic exfiltration test, an owner shall seal all wastewater pipes coming into a manhole with an internal pipe plug, fill the manhole with water, and maintain the test for at least one hour.
      - A test for concrete manholes may use a 24-hour wetting period before testing to allow saturation of the concrete.
    - Vacuum Testing.
      - To perform a vacuum test, an owner shall plug all lift holes and exterior joints with a non-shrink grout and plug all pipes entering a manhole.
      - No grout must be placed in horizontal joints before testing.
      - Stub-outs, manhole boots, and pipe plugs must be secured to prevent movement while a vacuum is drawn.
      - An owner shall use a minimum 80 inch/lb torque wrench to tighten the external clamps that secure a test cover to the top of a manhole.
      - A test head must be placed at the inside of the top of a cone section, and the seal inflated in accordance with the manufacturer's recommendations.
      - There must be a vacuum of 10 inches of mercury inside a manhole to perform a valid test.
      - A test does not begin until after the vacuum pump is off.
      - A manhole passes the test if after 2.0 minutes and with all valves closed, the vacuum is at least 9.0 inches of mercury.

CITY OF NEW BRAUNFELS NOTES:

- NO VALVES, HYDRANTS, ETC. SHALL BE CONSTRUCTED WITHIN CURBS, SIDEWALKS, OR DRIVEWAYS.
- ALL UTILITIES TO BE CONSTRUCTED PRIOR TO STREETS.
- THIS PROJECT INCLUDES UTILITY INSTALLATIONS GREATER THAN 6-FEET IN DEPTH. DEEP TRENCHES POSE COMPACTION TESTING AND CONSTRUCTION CHALLENGES AND CITY METHODS FOR TESTING AND COMPACTION MAY NOT BE ACHIEVABLE. A UTILITY COMPACTION PLAN WILL BE REQUIRED AND MUST BE SUBMITTED FOR APPROVAL TO CITY PRIOR TO UTILITY INSTALLATION.
- UTILITY TRENCH COMPACTION - ALL UTILITY TRENCH COMPACTION TESTS WITHIN THE STREET PAVEMENT/SIDEWALK SECTION SHALL BE THE RESPONSIBILITY OF THE DEVELOPER'S GEOTECHNICAL ENGINEER. FILL MATERIAL SHALL BE PLACED IN UNIFORM LAYERS NOT TO EXCEED TWELVE INCHES (12") LOOSE. DETERMINE THE MAXIMUM LIFT THICKNESS BASED ON THE ABILITY OF THE COMPACTING OPERATION AND EQUIPMENT USED TO MEET THE REQUIRED DENSITY. EACH LAYER OF MATERIAL SHALL BE COMPACTED TO A MINIMUM 85% DENSITY AND TESTED FOR DENSITY AND MOISTURE IN ACCORDANCE WITH TEST METHODS TEX-113-E, TEX-114-E, TEX-115-E. THE NUMBER AND LOCATION OF REQUIRED TESTS SHALL BE DETERMINED BY THE GEOTECHNICAL ENGINEER AND APPROVED BY THE CITY OF NEW BRAUNFELS STREET INSPECTOR AT A MINIMUM. TESTS SHALL BE TAKEN EVERY 200 LF FOR EACH LIFT AND EVERY OTHER SERVICE LINE. UPON COMPLETION OF TESTING THE GEOTECHNICAL ENGINEER SHALL PROVIDE THE CITY OF NEW BRAUNFELS STREET INSPECTOR WITH ALL TESTING DOCUMENTATION AND A CERTIFICATION STATING THAT THE PLACEMENT OF FILL MATERIAL HAS BEEN COMPLETED IN ACCORDANCE WITH THE PLANS. ADDITIONAL DENSITY TESTS MAY BE REQUESTED BY THE CITY OF NEW BRAUNFELS INSPECTOR.

- All private service laterals must be inspected and certified in accordance with 30 TAC §213.5(c)(3)(i). After installation of and, prior to covering and connecting a private service lateral to an existing organized sewage collection system, a Texas Licensed Professional Engineer, Texas Registered Sanitarian, or appropriate city inspector must visually inspect the private service lateral and the connection to the sewage collection system, and certify that it is constructed in conformity with the applicable provisions of this section. The owner of the collection system must maintain such certifications for five years and forward copies to the appropriate regional office upon request. Connections may only be made to an approved sewage collection system.

Austin Regional Office 12100 Park 35 Circle, Building A Austin, Texas 78753-1008 Phone (512) 339-2929 Fax (512) 339-3795	San Antonio Regional Office 14250 Judson Road San Antonio, Texas 78233-4480 Phone (210) 490-3096 Fax (210) 545-4329
--	---

**THESE GENERAL CONSTRUCTION NOTES MUST BE INCLUDED ON THE CONSTRUCTION PLANS PROVIDED TO THE CONTRACTOR AND ALL SUBCONTRACTORS.**

TCEQ-0596 (Rev. July 15, 2015) Page 1 of 6

TCEQ-0596 (Rev. July 15, 2015) Page 2 of 6

TCEQ-0596 (Rev. July 15, 2015) Page 3 of 6

executive director has reviewed and approved the methods proposed to protect the sensitive feature and the Edwards Aquifer from any potentially adverse impacts to water quality while maintaining the structural integrity of the line.

- Sewer lines located within or crossing the 5-year floodplain of a drainage way will be protected from inundation and stream velocities which could cause erosion and scouring of backfill. The trench must be capped with concrete to prevent scouring of backfill, or the sewer lines must be encased in concrete. All concrete shall have a minimum thickness of 6 inches.
- Blasting procedures for protection of existing sewer lines and other utilities will be in accordance with the National Fire Protection Association criteria. Sand is not allowed as bedding or backfill in trenches that have been blasted. If any existing sewer lines are damaged, the lines must be repaired and retested.
- All manholes constructed or rehabilitated on this project must have watertight size on size resilient connectors allowing for differential settlement. If manholes are constructed within the 100-year floodplain, the cover must have a gasket and be bolted to the ring. Where gasketed manhole covers are required for more than three manholes in sequence or for more than 1500 feet, alternate means of venting will be provided. Bricks are not an acceptable construction material for any portion of the manhole.

The diameter of the manholes must be a minimum of four feet and the manhole for entry must have a minimum clear opening diameter of 30 inches. These dimensions and other details showing compliance with the commission's rules concerning manholes and sewer line/manhole inverts described in 30 TAC §217.55 are included on Plan Sheet \_\_\_ of \_\_\_.

It is suggested that entrance into manholes in excess of four feet deep be accomplished by means of a portable ladder. The inclusion of steps in a manhole is prohibited.

- Where water lines and new sewer line are installed with a separation distance closer than nine feet (i.e., water lines crossing wastewater lines, water lines paralleling wastewater lines, or water lines next to manholes) the installation must meet the requirements of 30 TAC §217.53(g) (Pipe Design) and 30 TAC §290.44(e) (Water Distribution).

- When sewers line deviate from straight alignment and uniform grade all curvature of sewer pipe must be achieved by the following procedure which is recommended by the pipe manufacturer:
  - If pipe flexure is proposed, the following method of preventing deflection of the joint must be used:
    - Specific care must be taken to ensure that the joint is placed in the center of the trench and properly bedded in accordance with 30 TAC §217.54.

New sewage collection system lines must be constructed with stub outs for the connection of anticipated extensions. The location of such stub outs must be marked on the ground such that their location can be easily determined at the time of connection of the extensions. Such stub outs must be manufactured wyes or tees that are compatible in size and material with both the sewer line and the extension. At the time of original construction, new stub-outs must be constructed sufficiently to extend beyond the end of the street pavement. All stub-outs must be sealed with a manufactured cap to prevent leakage. Extensions that were not anticipated at the time of original construction or that are to be connected to an existing sewer line not furnished with stub outs must be connected using a manufactured saddle and in accordance with accepted plumbing techniques.

TCEQ-0596 (Rev. July 15, 2015) Page 2 of 6

TCEQ-0596 (Rev. July 15, 2015) Page 4 of 6

TCEQ-0596 (Rev. July 15, 2015) Page 5 of 6

**NEW WATER CONNECTION POLICY GENERAL NOTES:**

- ALL MATERIALS AND CONSTRUCTION PROCEDURES WITHIN THE SCOPE OF THE PROJECT SHALL BE APPROVED BY NEW BRAUNFELS UTILITIES AND COMPLY WITH THE CURRENT NEW BRAUNFELS UTILITIES WATER SYSTEMS CONNECTION/CONSTRUCTION POLICIES WATER SYSTEMS".
- CONTRACTOR SHALL NOT PROCEED WITH ANY PIPE INSTALLATION WORK UNTIL THEY OBTAIN A COPY OF THE PLANS FROM THE CONSULTANT OR ENGINEER AND NOTIFY NEW WATER SYSTEMS ENGINEERING AT 830-608-8971 WITH AT LEAST THREE (3) WORKING DAYS (72 HOURS) NOTICE. WORK COMPLETED BY THE CONTRACTOR, WHICH HAS NOT RECEIVED A NOTICE TO PROCEED WITH NEW BRAUNFELS UTILITIES WATER SYSTEMS ENGINEERING WILL BE SUBJECT TO REMOVAL AND REPLACEMENT BY AND AT THE EXPENSE OF THE CONTRACTOR.
- THE DEVELOPER DEDICATES THE WATER / WASTEWATER MAINS UPON COMPLETION BY THE DEVELOPER AND ACCEPTANCE BY THE NEW BRAUNFELS UTILITIES WATER SYSTEM. NBW WILL OWN AND MAINTAIN SAID WATER / WASTEWATER MAINS WHICH ARE LOCATED WITHIN SAID PARTICULAR SUBDIVISION. (AS APPLICABLE).
- CONTRACTOR AGREES TO ASSUME SOLE AND COMPLETE RESPONSIBILITY FOR JOB SITE CONDITIONS DURING THE CONSTRUCTION OF THE PROJECT, INCLUDING SAFETY OF ALL PERSONS AND PROPERTY. THIS REQUIREMENT SHALL APPLY CONTINUOUSLY AND NOT BE LIMITED TO NORMAL WORKING HOURS. THE CONTRACTOR SHALL DEFEND, INDEMNIFY AND HOLD THE OWNERS AND THE ENGINEER AND HIS EMPLOYEES, PARTNERS OFFICERS, DIRECTORS, OR CONSULTANTS HARMLESS FROM ANY AND ALL LIABILITY, REAL OR ALLEGED, IN CONNECTION WITH THE PERFORMANCE OF THE WORK ON THIS PROJECT, EXCEPTING FROM LIABILITY ARISING FROM SOLE NEGLIGENCE OF THE OWNER OR ENGINEER, ENGINEER'S DIRECTIONS, OFFICERS, EMPLOYEES, OR CONSULTANTS.
- CONTRACTOR AND / OR CONTRACTOR'S INDEPENDENTLY RETAINED EMPLOYEE OR SAFETY CONSULTANT SHALL IMPLEMENT A TRENCH SAFETY PROGRAM IN ACCORDANCE WITH OSHA STANDARDS GOVERNING THE PRESENCE AND ACTIVITIES OF INDIVIDUALS WORKING IN AND AROUND TRENCH EXCAVATION.
- CONTRACTOR SHALL BE RESPONSIBLE FOR RESTORING TO ITS ORIGINAL OR BETTER CONDITION, ANY DAMAGES DONE TO EXISTING FENCES, CURBS, STREETS, DRIVEWAYS, LANDSCAPING AND STRUCTURES, AND EXISTING UTILITIES (NOT ADJUSTED ON PLANS). COST OF RESTORATIONS, IF ANY, SHALL BE THE CONTRACTOR'S ENTIRE EXPENSE.
- THE CONTRACTOR SHALL AVOID CUTTING ROOTS LARGER THAN ONE INCH IN DIAMETER WHEN EXCAVATING NEAR EXISTING TREES. EXCAVATION IN VICINITY OF TREES SHALL PROCEED WITH CAUTION.
- CONTRACTOR SHALL PROCURE ALL PERMITS AND LICENSES, PAY ALL CHARGES, FEES AND TAXES AND GIVE ALL NOTICES NECESSARY AND INCIDENTAL TO THE DUE AND LAWFUL PROSECUTION OF THE WORK.
- NO EXTRA PAYMENT SHALL BE ALLOWED FOR WORK CALLED FOR ON THE PLANS BUT NOT INCLUDED ON THE BID SCHEDULE. THIS INCIDENTAL WORK WILL BE REQUIRED AND SHALL BE INCLUDED UNDER THE PAY ITEM TO WHICH IT RELATES.
- CONTRACTOR IS RESPONSIBLE FOR REMOVAL OF ALL WASTE MATERIALS UPON PROJECT COMPLETION. THE CONTRACTOR SHALL NOT PERMANENTLY PLACE ANY WASTE MATERIALS IN THE 100-YEAR FLOOD PLAN WITHOUT FIRST OBTAINING AN APPROVED FLOOD PLAIN DEVELOPMENT PERMIT.
- THE CONTRACTOR SHALL NOT PLACE ANY MATERIALS ON THE RECHARGE ZONE OF THE EDWARDS AQUIFER WITHOUT AN APPROVED WATER POLLUTION ABATEMENT PLAN FROM THE TCEQ 31 TAC 313.4 AND 31 TAC 313.9.
- BARRICADES AND WARNING SIGNS SHALL CONFORM TO THE "TEXAS MANUAL ON UNIFORM TRAFFIC CONTROL DEVICES" AND SHALL BE LOCATED TO PROVIDE MAXIMUM PROTECTION TO THE PUBLIC AS WELL AS CONSTRUCTION PERSONNEL AND EQUIPMENT WHILE PROVIDING CONTINUOUS TRAFFIC FLOW AT ALL TIMES DURING CONSTRUCTION. THE CONTRACTOR IS RESPONSIBLE FOR MAINTAINING ALL DEVICES DURING CONSTRUCTION.
- CONTRACTOR IS REQUIRED TO VERIFY PROJECT ELEVATIONS. THE TERM "MATCH EXISTING" SHALL BE UNDERSTOOD TO SIGNIFY BOTH HORIZONTAL AND VERTICAL ALIGNMENT.
- THE LOCATION OF UTILITIES, EITHER UNDERGROUND OR OVERHEAD, SHOWN WITHIN THE RIGHT OF WAY ARE APPROXIMATE AND SHALL BE VERIFIED BY THE CONTRACTOR BEFORE BEGINNING CONSTRUCTION OPERATIONS.
- OSHA REGULATIONS PROHIBIT OPERATIONS THAT WILL BRING PERSONS OR EQUIPMENT WITHIN 10 FEET OF AN ENERGIZED LINE, WHERE WORKMEN AND/OR EQUIPMENT HAVE TO CROSS CLOSE TO AN ENERGIZED ELECTRICAL LINE. THE CONTRACTOR SHALL NOTIFY THE ELECTRICAL POWER COMPANY INVOLVED AND MAKE WHATEVER ADJUSTMENTS NECESSARY TO ENSURE THE SAFETY OF THOSE WORKMEN.
- IT SHALL BE THE CONTRACTOR'S RESPONSIBILITY TO LOCATE UTILITY SERVICE LINES AS REQUIRED FOR CONSTRUCTION. UTILITY COMPANIES ARE ALSO PREVIOUSLY MENTIONED IN "UTILITY COMPANY NOTIFICATION".
- DUE TO FEDERAL REGULATIONS TITLE 49, PART 192 (8), GAS COMPANIES MUST MAINTAIN ACCESS TO GAS VALVES AT ALL TIMES. THE CONTRACTOR MUST PROTECT AND WORK AROUND ANY GAS VALVES THAT ARE IN THE PROJECT AREA.
- THE CONTRACTOR IS FULLY RESPONSIBLE FOR THE TRAFFIC CONTROL AND WILL BE RESPONSIBLE FOR FURNISHING ALL TRAFFIC CONTROL DEVICES, AND FLAGGERS. THE CONSTRUCTION METHODS SHALL BE CONDUCTED TO PROVIDE THE LEAST POSSIBLE INTERFERENCE TO TRAFFIC SO AS TO PERMIT THE CONTINUOUS MOVEMENT OF THE TRAFFIC IN ONE DIRECTION AT ALL TIMES. THE CONTRACTOR SHALL CLEAN UP AND REMOVE FROM THE WORK AREA ANY LOOSE MATERIAL, RESULTING FROM CONTRACT OPERATIONS AT THE END OF EACH WORKDAY.
- PRIOR TO ORDERING MATERIALS TO BE USED IN CONSTRUCTION, CONTRACTOR SHALL PROVIDE THE ENGINEER WITH FOUR (4) COPIES OF THE SOURCE, TYPE, GRADATION, MATERIAL SPECIFICATION DATA AND / OR SHOP DRAWINGS, AS APPLICABLE, TO SATISFY THE REQUIREMENTS OF THE FOLLOWING ITEMS AND ALL MATERIAL ITEMS REFERRED TO IN THESE LISTINGS:
  - WATER MAINS AND SERVICES
  - SEWER MAINS AND SERVICES
- NO METER BOXES TO BE SET IN DRIVEWAYS. ANY METER BOXES SET IN DRIVEWAYS WILL BE RELOCATED AT CONTRACTOR'S AND/OR DEVELOPER'S EXPENSE.
- WHERE THE MINIMUM 9 FOOT SEPARATION DISTANCE BETWEEN SEWER LINES AND WATER LINES / MAINS CANNOT BE MAINTAINED, THE INSTALLATION OF SEWER LINES SHALL BE IN STRICT ACCORDANCE WITH TCEQ.
- CONTRACTOR AND/OR CONTRACTOR'S INDEPENDENTLY RETAINED EMPLOYEE OR STRUCTURAL DESIGN/GEOTECHNICAL SAFETY/EQUIPMENT CONSULTANT, IF ANY, SHALL REVIEW THESE PLANS AND AVAILABLE GEOTECHNICAL INFORMATION AND THE ANTICIPATED INSTALLATION SITE(S) WITHIN THE PROJECT WORK AREA IN ORDER TO IMPLEMENT CONTRACTOR'S TRENCH EXCAVATION SAFETY PROTECTION SYSTEMS, PROGRAMS AND/OR PROCEDURES. THE CONTRACTOR'S IMPLEMENTATION OF THE SYSTEMS, PROGRAMS AND/OR PROCEDURES SHALL PROVIDE FOR ADEQUATE TRENCH EXCAVATION SAFETY PROTECTION THAT COMPLIES WITH AS A MINIMUM, OSHA STANDARDS FOR TRENCH EXCAVATIONS. SPECIFICALLY, CONTRACTOR AND/OR CONTRACTOR'S INDEPENDENTLY RETAINED EMPLOYEE OR SAFETY CONSULTANT SHALL IMPLEMENT A TRENCH SAFETY PROGRAM IN ACCORDANCE WITH OSHA STANDARDS GOVERNING THE PRESENCE AND ACTIVITIES OF INDIVIDUALS WORKING IN AND AROUND TRENCH EXCAVATION.
- UTILITY TRENCH COMPACTION WITH STREET R.O.W.

1. ALL UTILITY TRENCH COMPACTION TEST WITHIN THE STREET PAVEMENT SECTION SHALL BE THE RESPONSIBILITY OF THE DEVELOPER'S GEO-TECHNICAL ENGINEER.

2. FILL MATERIAL SHALL BE PLACED IN UNIFORM LAYERS NOT TO EXCEED TWELVE INCHES (12") LOOSE.

3. EACH LAYER OF MATERIAL SHALL BE COMPACTED AS SPECIFIED AND TESTED FOR DENSITY AND MOISTURE IN ACCORDANCE WITH TEST METHODS TEX-113-E, TEX-114-E, TEX-115-E.

4. THE NUMBER AND LOCATION OF REQUIRED TESTS SHALL BE DETERMINED BY THE GEO-TECHNICAL ENGINEER AND APPROVED BY THE CITY OF NEW BRAUNFELS STREET INSPECTOR.

5. UPON COMPLETION OF TESTING THE GEO-TECHNICAL ENGINEER SHALL PROVIDE THE CITY OF NEW BRAUNFELS STREET INSPECTOR WITH ALL TESTING DOCUMENTATION AND A CERTIFICATION STATING THAT THE PLACEMENT OF FILL MATERIAL HAS BEEN COMPLETED IN ACCORDANCE WITH THE PLANS.

VERAMENDI PRECINCT 18 UNIT 2

WASTEWATER DETAILS (SHEET 2 OF 2)

DATE	BY	DESCRIPTION	NO.
10/26/2023	NG	DESIGNED BY	
	TM	DRAWN BY	
	PF	CHECKED BY	
		DRAWING NAME:	05_Wastewater_Details.dwg

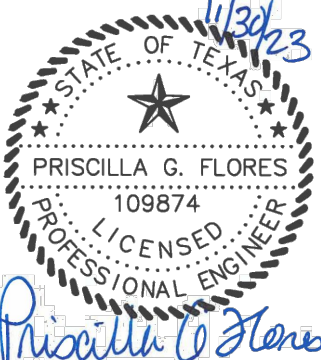

**LJA Engineering, Inc.**  
9830 Colonnade Blvd  
Suite 300  
San Antonio, Texas 78230  
Phone 210.503.2700  
LJA.COM  
TBP# No. F-1386

JOB NUMBER:  
SA3856.0402

SHEET NO.

62

OF 71 SHEETS

FOR PERMIT

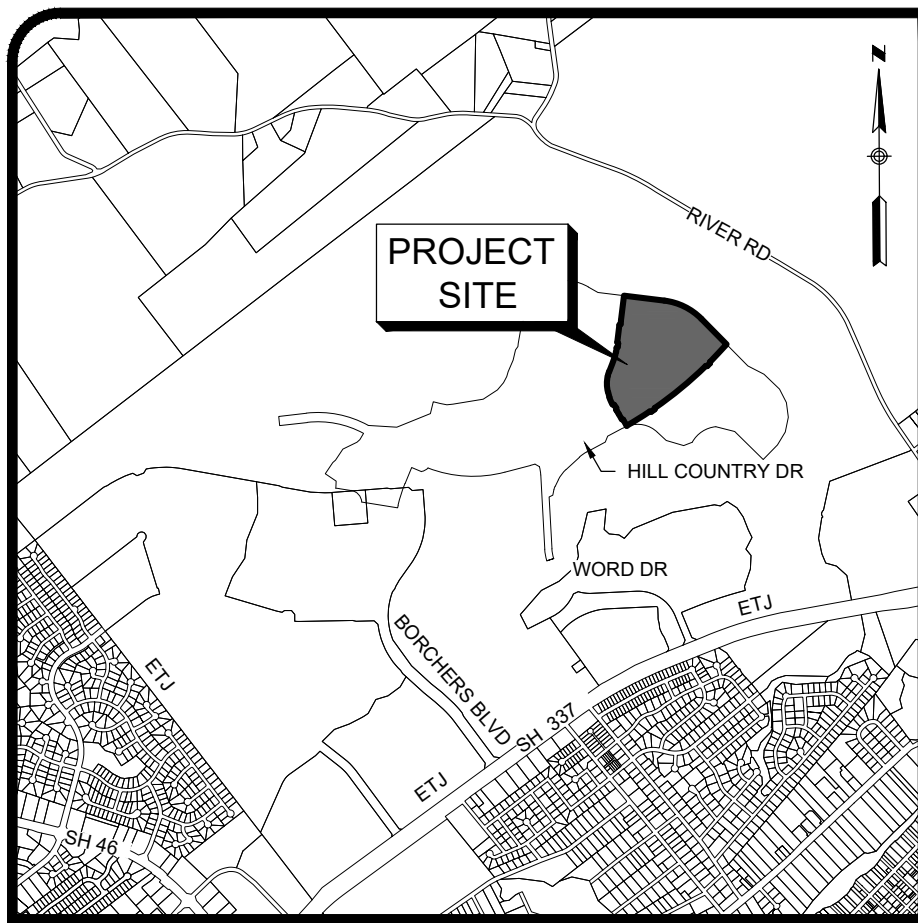

LOCATION MAP  
N.T.S.

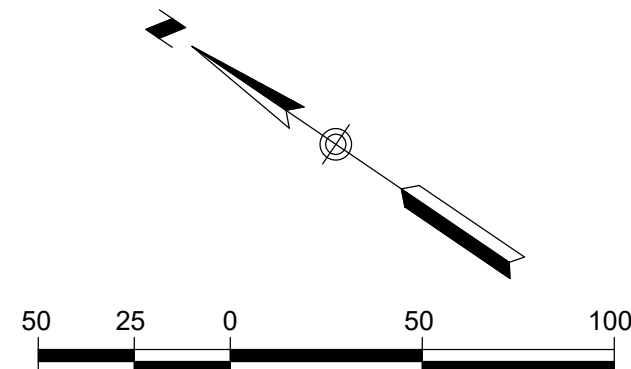

SCALE IN FEET  
SCALE: 1"=50'

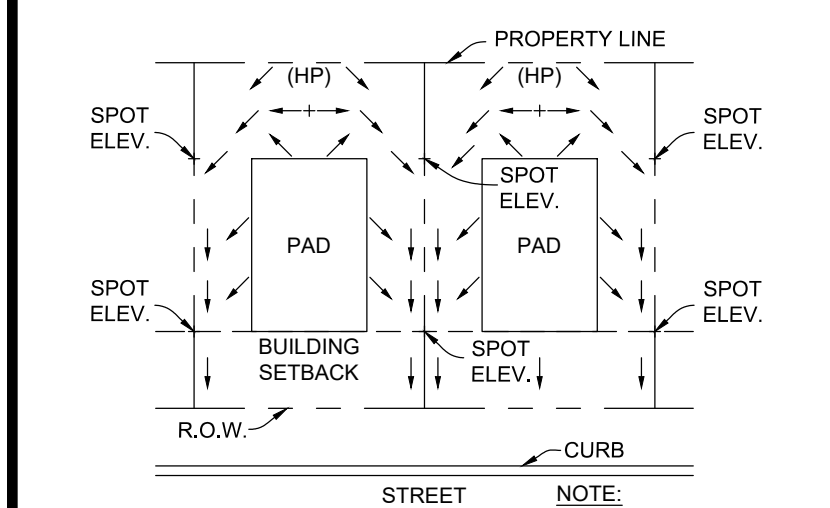

TYPICAL "A" LOT GRADING  
N.T.S.

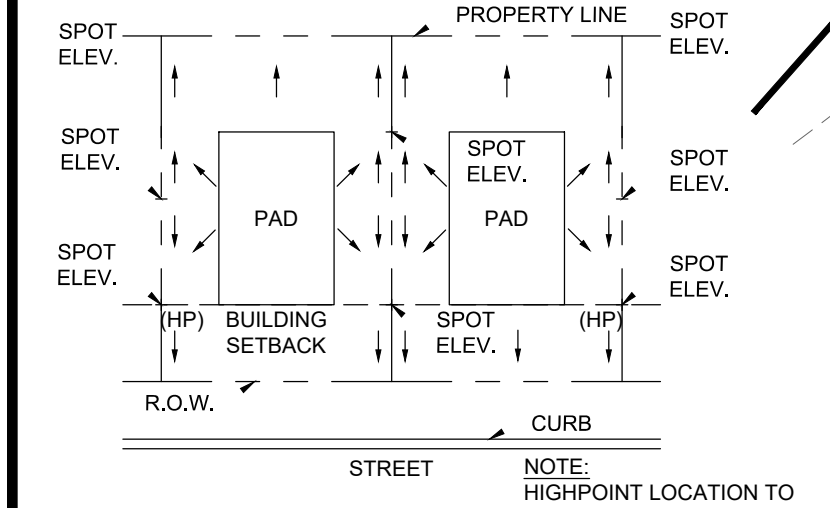

TYPICAL "B" LOT GRADING  
N.T.S.

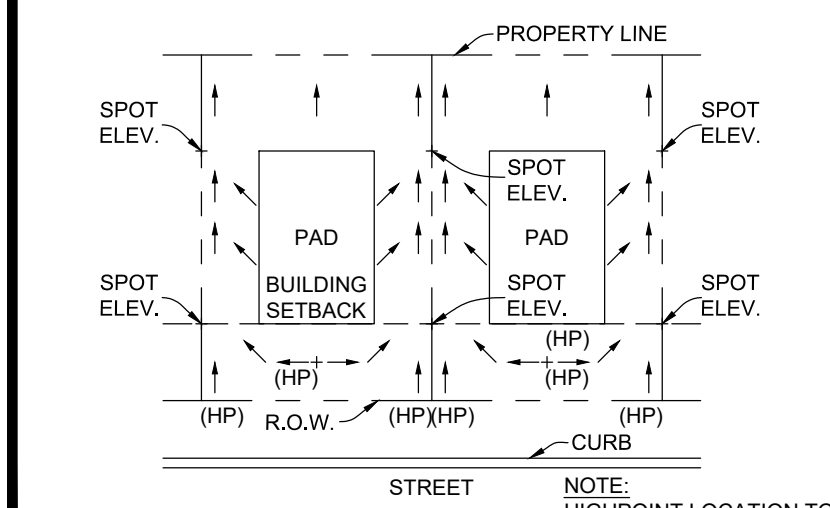

TYPICAL "C" LOT GRADING  
N.T.S.

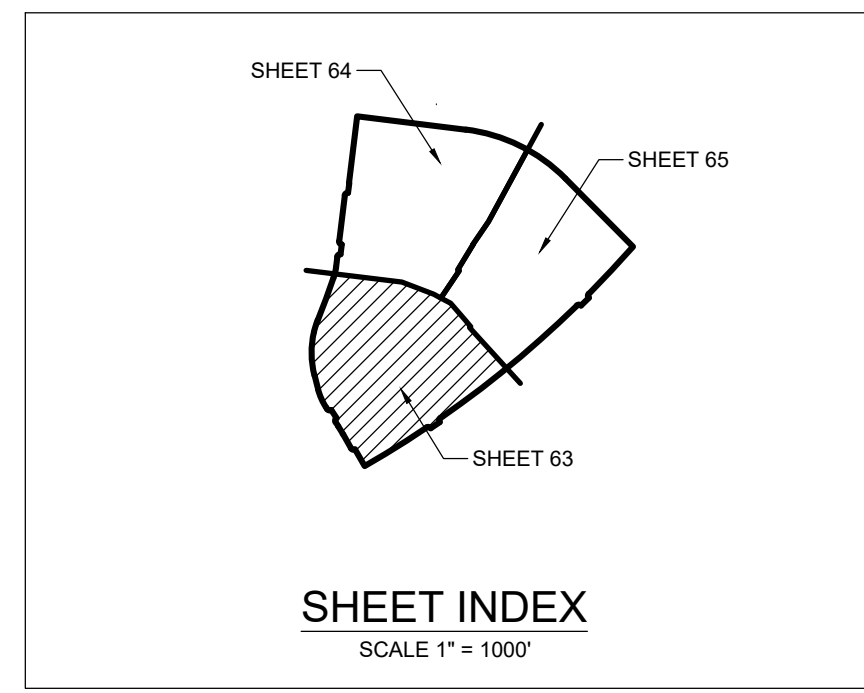

SHEET INDEX  
SCALE 1" = 1000'

LOCATION OF EXISTING UNDERGROUND AND OVERHEAD UTILITIES ARE APPROXIMATE LOCATIONS ONLY. THE CONTRACTOR SHALL DETERMINE THE EXACT LOCATION OF ALL EXISTING UTILITIES PRIOR TO BEGINNING WORK AND SHALL BE FULLY RESPONSIBLE FOR ANY AND ALL DAMAGES WHICH MIGHT OCCUR.



LEGEND		
PROPOSED	EXISTING	
800	800	CONTOUR
2%	2%	FLOW ARROW
X 706.41	X 801.33	GRASSED DRAIN FLOW
X TOW 706.41	X EX TOW 706.41	GROUND ELEVATION
X BOW 706.41	X EX BOW 706.41	TOP OF RETAINING WALL ELEVATION
X 706.41 ME	X EX BOW 706.41	BOTTOM OF RETAINING WALL ELEVATION
		MATCH EXISTING GROUND
(A)		LOT DRAIN TO FRONT
(B)		LOT DRAIN TO REAR
(C)		LOT TYPE A MODIFIED
(Am)		LOT TYPE B MODIFIED
(Bm)		LOT TYPE C MODIFIED
(Cm)		TOP OF MANHOLE
		EXISTING
		GAS, ELEC, TELE & CABLE TV ESMT.
		EASEMENT
		VOLUME
		PAGE
		RETAINING WALL

**GRADING NOTES**

- ALL MATERIALS AND CONSTRUCTION PROCEDURES WITHIN THIS SCOPE OF WORK WHERE NOT SPECIFICALLY COVERED IN THE SPECIFICATIONS OR GEOTECHNICAL REPORT SHALL CONFORM TO ALL APPLICABLE CITY, COUNTY AND TxDOT STANDARD SPECIFICATIONS FOR PUBLIC WORKS CONSTRUCTION (LATEST EDITION).
- SITE PREPARATION, GRADING, EXCAVATION AND FILL SHALL BE PERFORMED IN ACCORDANCE WITH THE GEOTECHNICAL REPORT AND SPECIFICATIONS.
- ALL SELECT FILL MATERIAL PROVIDED SHALL BE APPROVED BY THE GEOTECHNICAL ENGINEER PRIOR TO PLACING AND COMPACTING.
- ALL ELEVATIONS AND PROPOSED CONTOURS SHOWN ON THIS GRADING PLAN REFLECT FINISHED GRADES. THE THICKNESS OF PAVING, BASE, GRASS, TOPSOIL, AND MULCH MUST BE SUBTRACTED TO OBTAIN SUBGRADE ELEVATIONS.
- THE CONTRACTOR SHALL IMMEDIATELY NOTIFY THE ENGINEER OF ANY QUESTIONS THAT MAY ARISE CONCERNING THE INTENT, PLACEMENT, OR LIMITS OF DIMENSIONS OR GRADES NECESSARY FOR CONSTRUCTION OF THIS PROJECT.
- CONTRACTOR SHALL VERIFY THE SUITABILITY OF ALL EXISTING AND PROPOSED SITE CONDITIONS INCLUDING GRADES AND DIMENSIONS BEFORE COMMENCEMENT OF CONSTRUCTION. THE ENGINEER SHALL BE NOTIFIED IMMEDIATELY OF ANY DISCREPANCIES.
- THE CONTRACTOR SHALL BE RESPONSIBLE FOR ACQUIRING ALL PERMITS, TESTS, APPROVALS AND ACCEPTANCES REQUIRED TO COMPLETE CONSTRUCTION OF THIS PROJECT.
- CONTRACTOR SHALL REMOVE TOP SOIL, GRASS, ROOTS, DEBRIS, ETC. AND DISPOSE OFF SITE THOSE MATERIALS NOT SUITABLE FOR EMBANKMENT AND TOPSOIL. CLEAN STRIPPINGS AND TOPSOIL MAY BE STOCKPILED ON SITE FOR REUSE IN A LOCATION SPECIFIED BY THE OWNER.
- THE SITE CONTRACTOR SHALL BE RESPONSIBLE FOR SITE STABILIZATION, ALL DISTURBED AREAS SHALL BE REVEGETATED IN ACCORDANCE WITH PROJECT SPECIFICATIONS AND TPDES/SWPPP REQUIREMENTS. REFERENCE THE LANDSCAPE ARCHITECT'S PLAN, IF APPLICABLE.
- CONTRACTOR SHALL TAKE ALL NECESSARY PRECAUTIONS (USE OF SILT FENCES, ETC.) TO KEEP DRAINAGE AND SILT FROM WASHING ONTO ADJACENT PROPERTY, STREETS, OR DRAINAGEWAYS. CONTRACTOR SHALL IMMEDIATELY REMOVE SILT/DEBRIS WHICH WASHES OFFSITE OR INTO EXISTING STORM DRAIN SYSTEMS. (SEE SWPPP PLANS & TPDES BOOK).
- THE CONTRACTOR SHALL OBTAIN GRADES SHOWN HEREON WITHIN +/- ONE-TENTH (0.10) FOOT.
- PROMISED PAVING AREAS. STREET DESIGN PLANS SHALL CONTROL ALL EARTHEN SLOPES SHALL BE A MAXIMUM OF 3:1 AND A MINIMUM OF 1.0% UNLESS OTHERWISE SHOWN.
- CONTRACTOR SHALL PROVIDE A SMOOTH TRANSITION BETWEEN EXISTING SITE AND PROPOSED IMPROVEMENTS.
- CONTRACTOR SHALL BE RESPONSIBLE FOR RESTORING TO ITS ORIGINAL OR BETTER CONDITION ANY DAMAGE DONE TO EXISTING TREES, BUILDINGS, UTILITIES, FENCES, PAVEMENT, CURBS, OR DRIVEWAYS (NO SEPARATE PAY ITEMS).
- THE CONTRACTOR SHALL EXERCISE EXTREME CAUTION IN WORKING NEAR UTILITIES. GAS LINES, SEWER, OR EXISTING APPURTENANCES. PRIOR TO PERFORMING ANY EXCAVATION, CONTRACTOR SHALL CONTACT ALL UTILITY COMPANIES AND ASSURE HIMSELF THAT ALL UTILITIES HAVE BEEN ADEQUATELY LOCATED AND IDENTIFIED. THE ENGINEER SHALL BE NOTIFIED IF ANY UTILITY CONFLICTS ARE DISCOVERED.
- UTILITIES SHOWN ON THE PLANS ARE FROM INFORMATION SOURCES AVAILABLE AT THE TIME OF DESIGN BUT MAY NOT REPRESENT ALL EXISTING UTILITIES ON SITE. THE CONTRACTOR WILL BE RESPONSIBLE FOR DETERMINING EXACT LOCATION OF ALL UTILITIES WHETHER SHOWN ON THE PLANS OR NOT. THE CONTRACTOR SHALL UNCOVER EXISTING UTILITIES PRIOR TO CONSTRUCTION AND VERIFY SIZE, GRADE AND LOCATION. THE CONTRACTOR SHALL NOTIFY THE ENGINEER IMMEDIATELY OF ANY DEVIATIONS FROM PLANS PRIOR TO BEGINNING CONSTRUCTION. ANY DAMAGE TO EXISTING UTILITIES, WHETHER SHOWN ON THE PLANS OR NOT, SHALL BE THE CONTRACTOR'S RESPONSIBILITY TO REPAIR, AT HIS OWN EXPENSE.
- POSITIVE DRAINAGE SHALL BE MAINTAINED THROUGHOUT THE SCOPE OF THE PROJECT. DRAINAGE SHALL BE DIRECTED AWAY FROM ALL BUILDING FOUNDATIONS. CONTRACTOR SHOULD TAKE PRECAUTIONS NOT TO ALLOW ANY FLOODING OF WATER.
- FILL PLACEMENT ON HILL SIDES OR STEEP SLOPE AREAS. THE CONTRACTOR SHALL REFERENCE THE PROJECT SPECIFICATIONS AND GEOTECHNICAL REPORT FOR SPECIAL INSTRUCTIONS REGARDING BENCHING.
- WORK SHALL BE PERFORMED IN A PUBLIC RIGHT-OF-WAY WITHOUT A PERMIT.
- STORMWATER DETENTION FROM PROJECT SITES SHALL BE PHASED SO AS TO EXPOSE THE MINIMUM AMOUNT OF AREA TO SOIL EROSION FOR THE SHORTEST POSSIBLE PERIOD OF TIME PER THE NEW BRAUNFELS DRAINAGE AND EROSION CONTROL DESIGN MANUAL SEC.12.2(N).



VERAMENDI PRECINCT 18 UNIT 2  
GRADING PLAN (SHEET 1 OF 3)

NO.	DATE	DESCRIPTION
11/03/2023	NG	DESIGNED BY
	TM	DRAWN BY
	PGF	CHECKED BY
		DRAWING NAME: 18-Grading Plan.dwg



**LJA Engineering, Inc.**  
9830 Colonnade Blvd  
Suite 300  
San Antonio, Texas 78230  
Phone 210.503.2700  
LJA.COM  
TBP# No. F-1386

JOB NUMBER: SA3856.0402

SHEET NO. 63

OF 71 SHEETS

FOR PERMIT

K:\AR\AS\ACA\Progress\0402\_Veramendi\_Precinct\_18-2\18-2\_Site\_Development\Plan\18-2\Grading\18-2\_Grading\_Plan.dwg  
Last Modified: Nov 03, 2023 09:43  
Plot Date: Nov 03, 2023 09:43

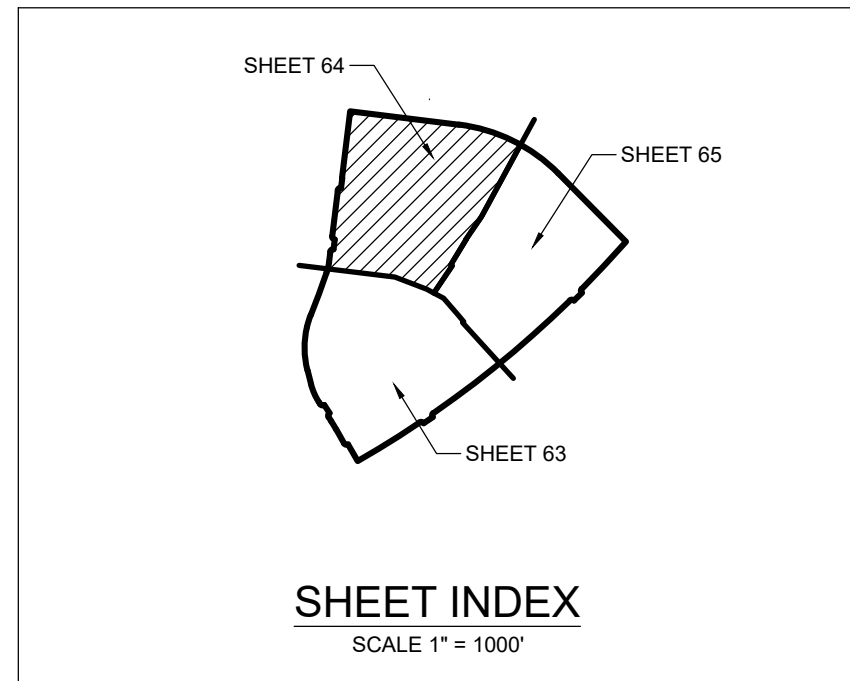
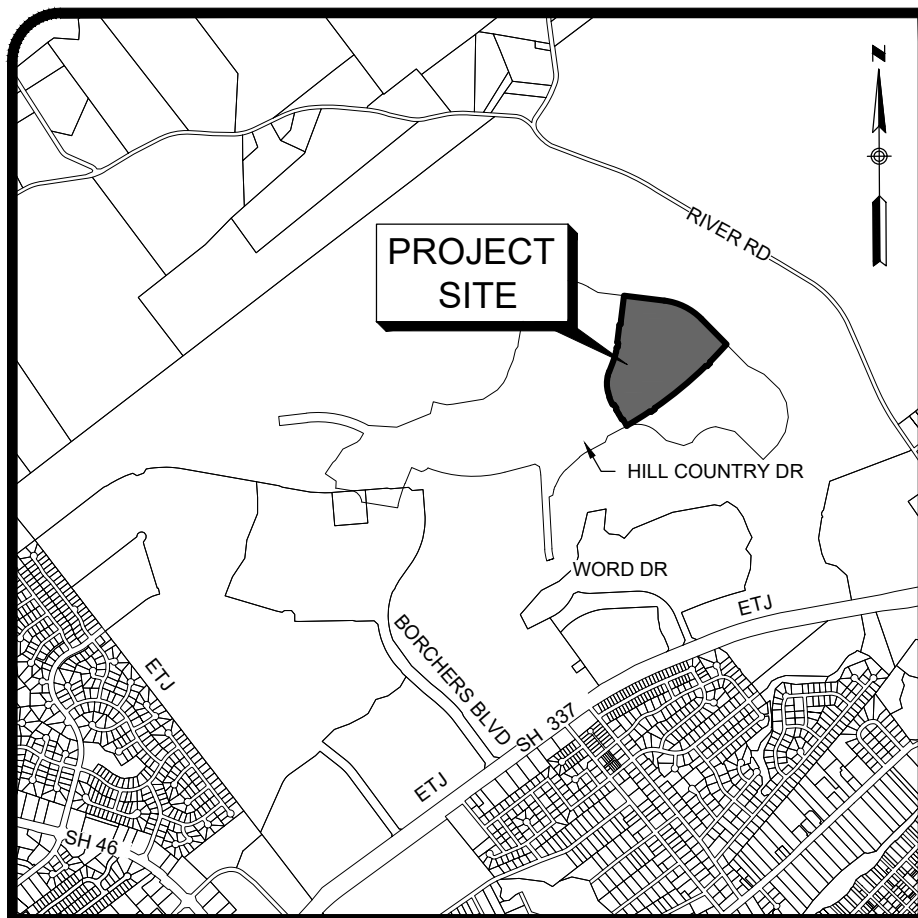

LOCATION OF EXISTING UNDERGROUND AND OVERHEAD UTILITIES ARE APPROXIMATE LOCATIONS ONLY. THE CONTRACTOR SHALL DETERMINE THE EXACT LOCATION OF ALL EXISTING UTILITIES PRIOR TO BEGINNING WORK AND SHALL BE FULLY RESPONSIBLE FOR ANY AND ALL DAMAGES WHICH MIGHT OCCUR.

**811**  
Know what's below.  
Call before you dig.

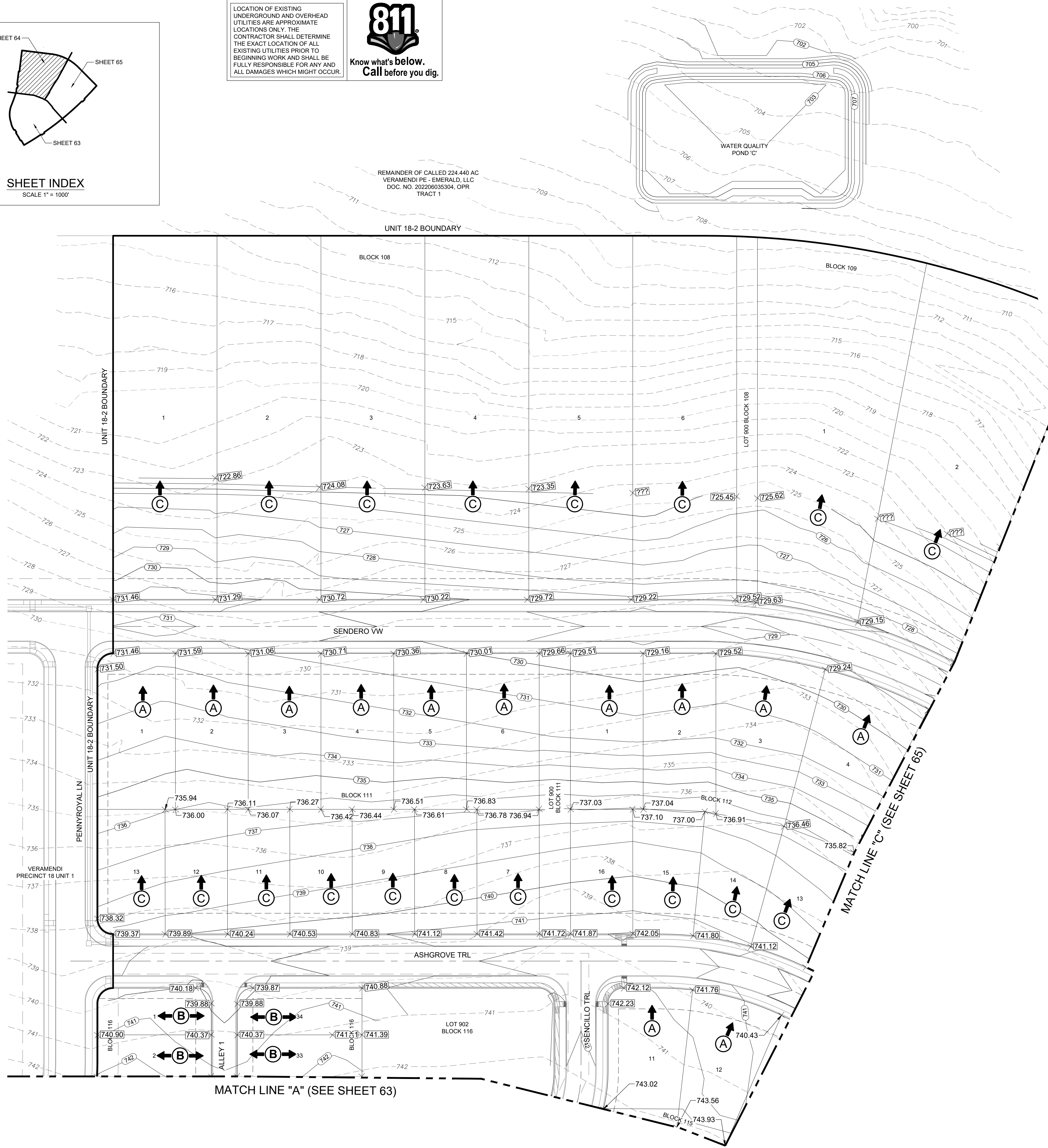
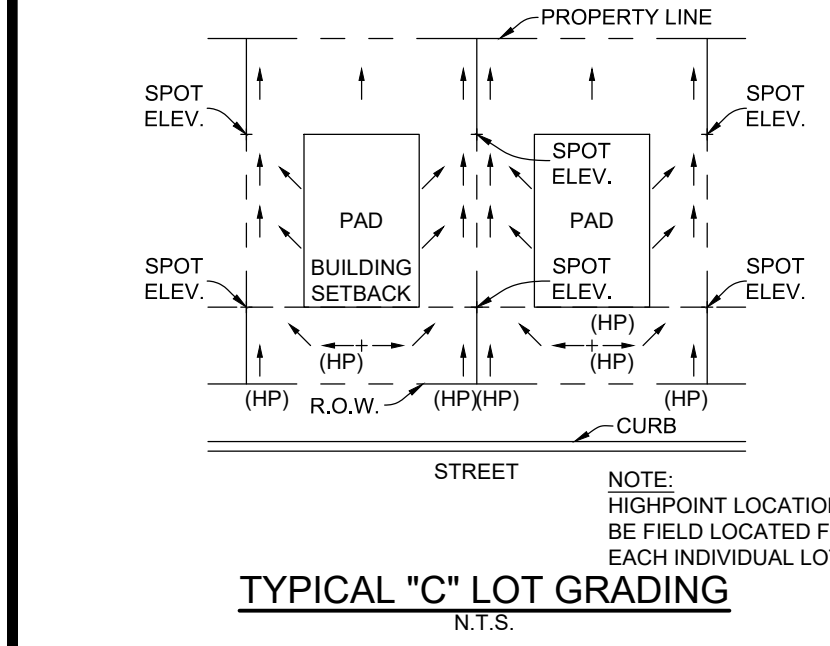
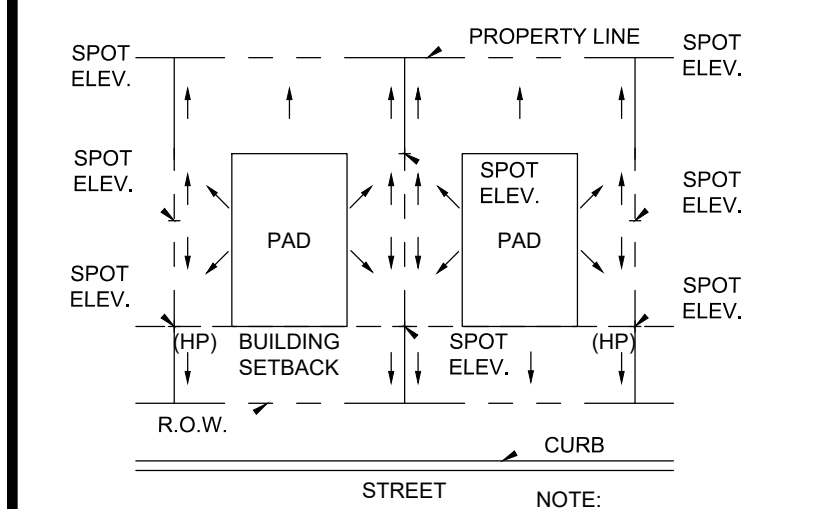
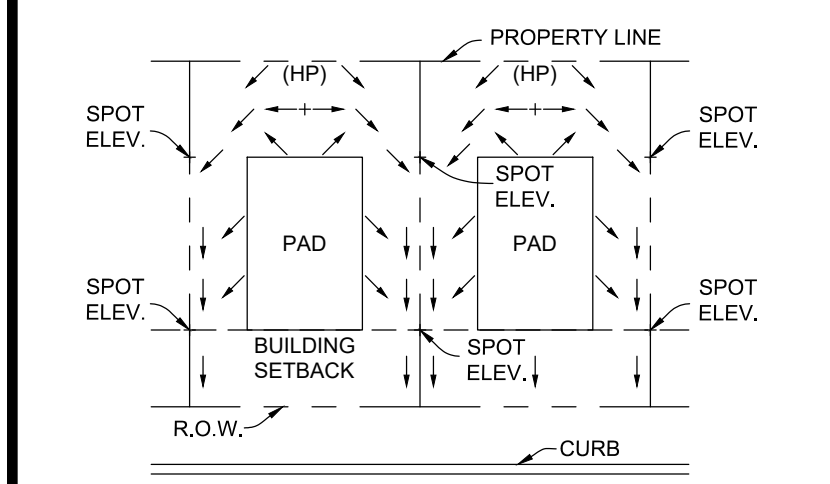
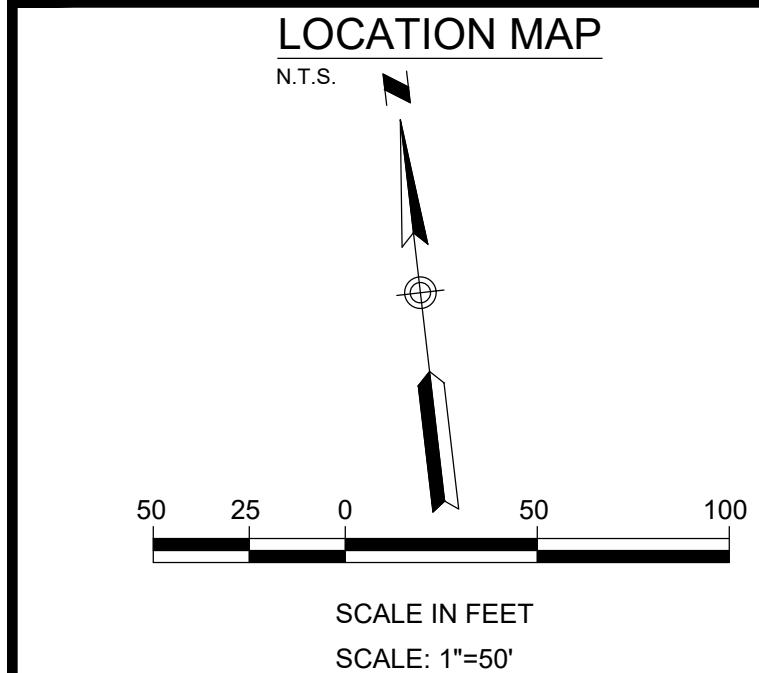

**LEGEND**

PROPOSED	EXISTING	
800	800	CONTOUR
2%	2%	FLOW ARROW
---	---	GRASSED DRAIN FLOW
X 706.41	X 801.33	GROUND ELEVATION
X 706.41 ME		MATCH EXISTING GROUND
(A)		LOT DRAINS TO FRONT
(B)		LOT DRAINS 1/2 TO FRONT AND 1/2 TO REAR
(C)		LOT DRAINS TO REAR
(Am)		LOT TYPE A MODIFIED
(Bm)		LOT TYPE B MODIFIED
(Cm)		LOT TYPE C MODIFIED
		TMH
		EX.
		G,E,T,CA
		ESMT
		VOL
		PG
		RETAINING WALL

- GRADING NOTES**
- ALL MATERIALS AND CONSTRUCTION PROCEDURES WITHIN THIS SCOPE OF WORK WHERE NOT SPECIFICALLY COVERED IN THE SPECIFICATIONS OR GEOTECHNICAL REPORT SHALL CONFORM TO ALL APPLICABLE CITY, COUNTY AND TxDOT STANDARD SPECIFICATIONS FOR PUBLIC WORKS CONSTRUCTION (LATEST EDITION).
  - SITE PREPARATION, GRADING, EXCAVATION AND FILL SHALL BE PERFORMED IN ACCORDANCE WITH THE GEOTECHNICAL REPORT AND SPECIFICATIONS.
  - ALL SELECT FILL MATERIAL PROVIDED SHALL BE APPROVED BY THE GEOTECHNICAL ENGINEER PRIOR TO PLACING AND COMPACTING.
  - ALL ELEVATIONS AND PROPOSED CONTOURS SHOWN ON THIS GRADING PLAN REFLECT FINISHED GRADES. THE THICKNESS OF PAVING, BASE, GRASS, TOPSOIL, AND MULCH MUST BE SUBTRACTED TO OBTAIN SUBGRADE ELEVATIONS.
  - THE CONTRACTOR SHALL IMMEDIATELY NOTIFY THE ENGINEER OF ANY QUESTIONS THAT MAY ARISE CONCERNING THE INTENT, PLACEMENT, OR LIMITS OF DIMENSIONS OR GRADES NECESSARY FOR CONSTRUCTION OF THIS PROJECT.
  - CONTRACTOR SHALL VERIFY THE SUITABILITY OF ALL EXISTING AND PROPOSED SITE CONDITIONS INCLUDING GRADES AND DIMENSIONS BEFORE COMMENCEMENT OF CONSTRUCTION. THE ENGINEER SHALL BE NOTIFIED IMMEDIATELY OF ANY DISCREPANCIES.
  - THE CONTRACTOR SHALL BE RESPONSIBLE FOR ACQUIRING ALL PERMITS, TESTS, APPROVALS AND ACCEPTANCES REQUIRED TO COMPLETE CONSTRUCTION OF THIS PROJECT.
  - CONTRACTOR SHALL REMOVE TOP SOIL, GRASS, ROOTS, DEBRIS, ETC. AND DISPOSE OFF SITE THOSE MATERIALS NOT SUITABLE FOR EMBANKMENT AND TOPSOIL CLEAN STRIPPINGS AND TOPSOIL MAY BE STOCKPILED ON SITE FOR REUSE IN A LOCATION SPECIFIED BY THE OWNER.
  - THE SITE CONTRACTOR SHALL BE RESPONSIBLE FOR SITE STABILIZATION, ALL DISTURBED AREAS SHALL BE REVEGETATED IN ACCORDANCE WITH PROJECT SPECIFICATIONS AND TPDES/SWPPP REQUIREMENTS. REFERENCE THE LANDSCAPE ARCHITECT'S PLAN, IF APPLICABLE.
  - CONTRACTOR SHALL TAKE ALL NECESSARY PRECAUTIONS (USE OF SILT FENCES, ETC.) TO KEEP DRAINAGE AND SILT FROM WASHING ONTO ADJACENT PROPERTY, STREETS, OR DRAINAGE WAYS. CONTRACTOR SHALL IMMEDIATELY REMOVE SILT/DEBRIS WHICH WASHES OFFSITE OR INTO EXISTING STORM DRAIN SYSTEMS. (SEE SWPPP PLANS & TPDES BOOK).
  - THE CONTRACTOR SHALL OBTAIN GRADES SHOWN HEREON WITHIN +/- ONE-TENTH (0.10) FOOT.
  - PROMISED PAVING AREAS. STREET DESIGN PLANS SHALL CONTROL ALL EARTHEN SLOPES SHALL BE A MAXIMUM OF 3:1 AND A MINIMUM OF 1.0% UNLESS OTHERWISE SHOWN.
  - CONTRACTOR SHALL PROVIDE A SMOOTH TRANSITION BETWEEN EXISTING SITE AND PROPOSED IMPROVEMENTS.
  - CONTRACTOR SHALL BE RESPONSIBLE FOR RESTORING TO ITS ORIGINAL OR BETTER CONDITION ANY DAMAGE DONE TO EXISTING TREES, BUILDINGS, UTILITIES, FENCES, PAVEMENT, CURBS, OR DRIVEWAYS (NO SEPARATE PAY ITEMS).
  - THE CONTRACTOR SHALL EXERCISE EXTREME CAUTION IN WORKING NEAR UTILITIES, GAS LINES, SEWER, OR EXISTING APPURTENANCES. PRIOR TO PERFORMING ANY EXCAVATION, CONTRACTOR SHALL CONTACT ALL UTILITY COMPANIES AND ASSURE HIMSELF THAT ALL UTILITIES HAVE BEEN ADEQUATELY LOCATED AND IDENTIFIED. THE ENGINEER SHALL BE NOTIFIED IF ANY UTILITY CONFLICTS ARE DISCOVERED.
  - UTILITIES SHOWN ON THE PLANS ARE FROM INFORMATION SOURCES AVAILABLE AT THE TIME OF DESIGN BUT MAY NOT REPRESENT ALL EXISTING UTILITIES ON SITE. THE CONTRACTOR WILL BE RESPONSIBLE FOR DETERMINING EXACT LOCATION OF ALL UTILITIES WHETHER SHOWN ON THE PLANS OR NOT. THE CONTRACTOR SHALL UNCOVER EXISTING UTILITIES PRIOR TO CONSTRUCTION AND VERIFY SIZE, GRADE AND LOCATION. THE CONTRACTOR SHALL NOTIFY THE ENGINEER IMMEDIATELY OF ANY DEVIATIONS FROM PLANS PRIOR TO BEGINNING CONSTRUCTION. ANY DAMAGE TO EXISTING UTILITIES, WHETHER SHOWN ON THE PLANS OR NOT, SHALL BE THE CONTRACTORS RESPONSIBILITY TO REPAIR, AT HIS OWN EXPENSE.
  - POSITIVE DRAINAGE SHALL BE MAINTAINED THROUGHOUT THE SCOPE OF THE PROJECT. DRAINAGE SHALL BE DIRECTED AWAY FROM ALL BUILDING FOUNDATIONS. CONTRACTOR SHOULD TAKE PRECAUTIONS NOT TO ALLOW ANY PONDING OF WATER.
  - FILL PLACEMENT ON HILL SIDES OR STEEP SLOPE AREAS. THE CONTRACTOR SHALL REFERENCE THE PROJECT SPECIFICATIONS AND GEOTECHNICAL REPORT FOR SPECIAL INSTRUCTIONS REGARDING BENCHING.
  - WORK SHALL BE PERFORMED IN A PUBLIC RIGHT-OF-WAY WITHOUT A PERMIT.
  - STORMWATER DETENTION FROM PROJECT SITES SHALL BE PHASED SO AS TO EXPOSE THE MINIMUM AMOUNT OF AREA TO SOIL EROSION FOR THE SHORTEST POSSIBLE PERIOD OF TIME PER THE NEW BRAUNFELS DRAINAGE AND EROSION CONTROL DESIGN MANUAL SEC.12.2(N).

VERAMENDI PRECINCT 18 UNIT 2  
GRADING PLAN (SHEET 2 OF 3)

DATE: 11/03/2023  
DESIGNED BY: NG  
DRAWN BY: TM  
CHECKED BY: PGF  
DRAWING NAME: 18-Grading Plan.dwg  
TBPE No. F-1386

PRISCILLA G. FLORES  
109874  
PROFESSIONAL ENGINEER

LJA Engineering, Inc.  
9830 Calomarde Blvd  
Suite 300  
San Antonio, Texas 78230  
Phone 210.503.2700  
LJA.COM

JOB NUMBER: SA3856.0402  
SHEET NO. 64 OF 71 SHEETS

K:\QA\B564\_ASA\_Progress\0402\_Veremendi\_Precinct\_18-2\1408\_Site\_Development\Plan\18-Grading\18-Grading\_Plan.dwg  
Last Modified: Nov 03, 2023 09:43  
Plot Date: 11/03/2023 10:13:53







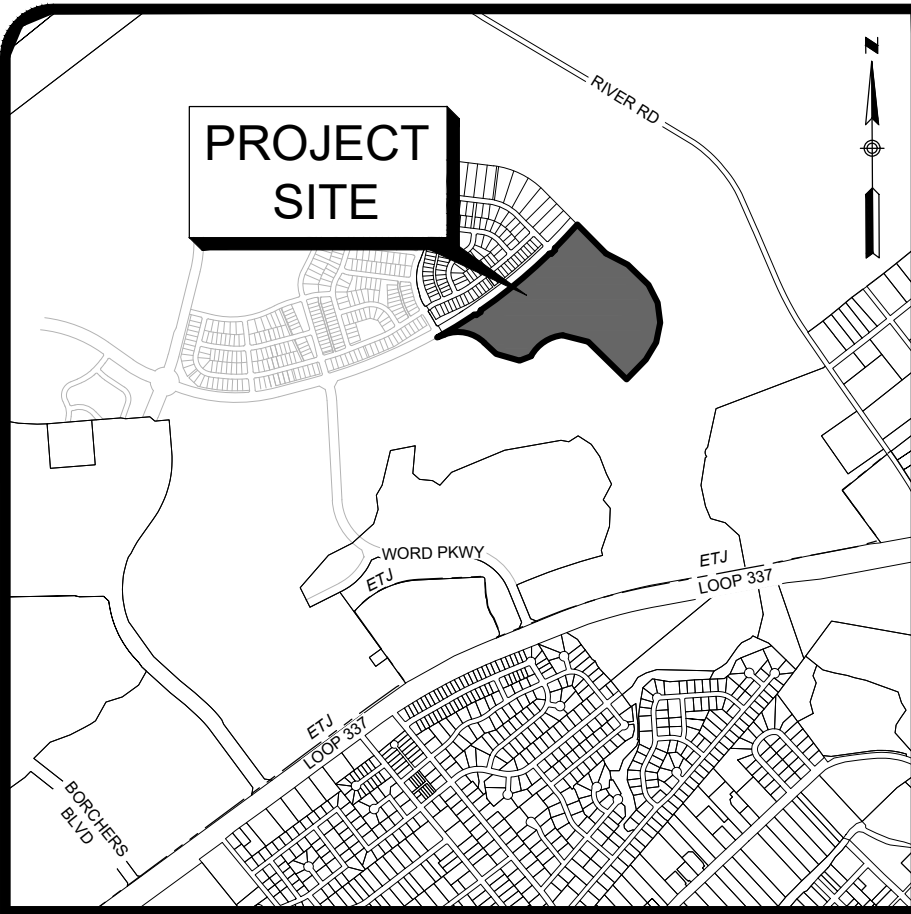

**LOCATION MAP**  
SCALE: 1" = 2000'

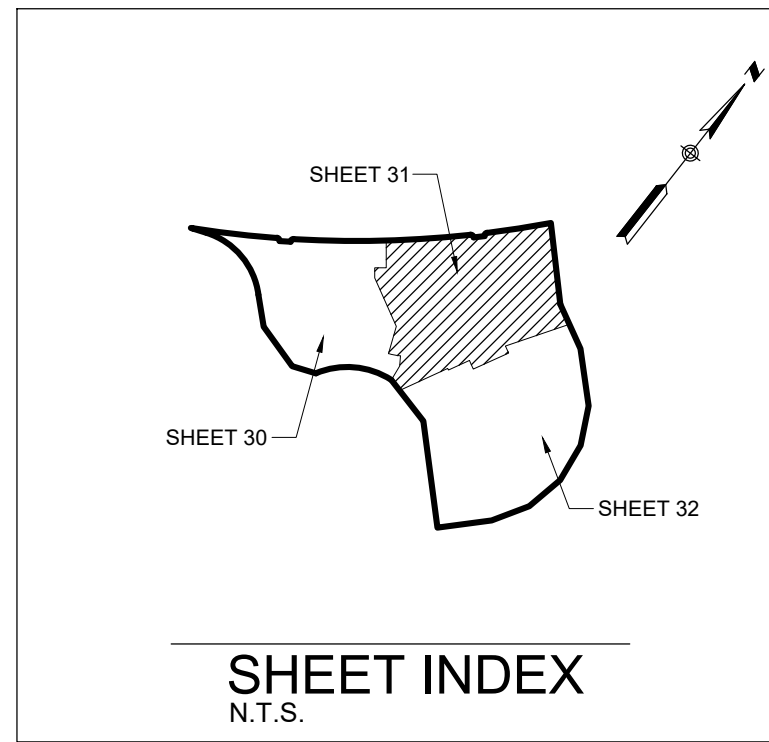

**SHEET INDEX**  
N.T.S.

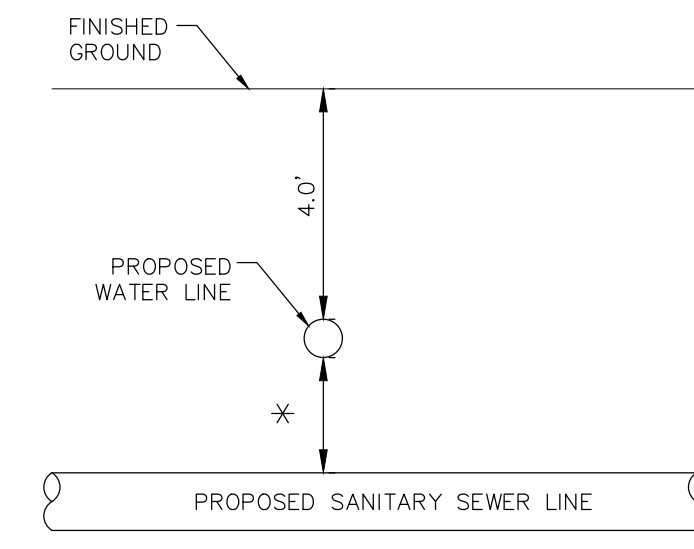

**TYPICAL SANITARY SEWER/WATER CROSSING DETAIL**  
NTS

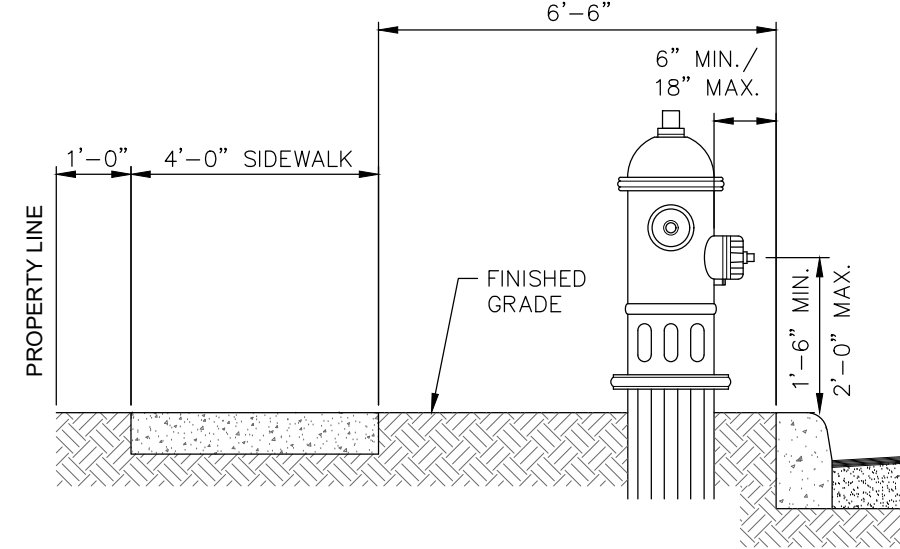

**FIRE HYDRANT LOCATION (WITH SIDEWALK)**  
NTS

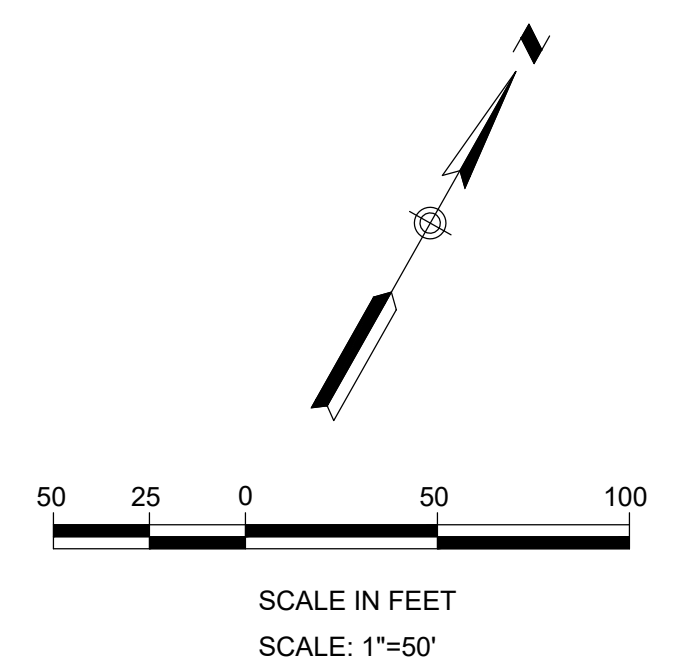

SCALE IN FEET  
SCALE: 1" = 50'

**CITY OF NEW BRAUNFELS NOTES**

- NO VALVES, HYDRANTS, ETC. SHALL BE CONSTRUCTED WITHIN CURBS, SIDEWALKS, OR DRIVEWAYS.
- ALL UTILITIES TO BE CONSTRUCTED PRIOR TO STREETS.
- THIS PROJECT INCLUDES UTILITY INSTALLATIONS GREATER THAN 5'-FEET IN DEPTH. DEEP TRENCHES POSE COMPACTION TESTING AN CHALLENGES AND CITY METHODS FOR TESTING AND COMPACTION MAY NOT BE ACHIEVABLE. A UTILITY COMPACTION PLAN WILL BE REQUIRED AND MUST BE SUBMITTED FOR APPROVAL TO CITY PRIOR TO UTILITY INSTALLATION.
- UTILITY TRENCH COMPACTION ALL UTILITY TRENCH COMPACTION TESTS WITHIN THE STREET PAVEMENT/SIDEWALK SECTION SHALL BE THE RESPONSIBILITY OF THE DEVELOPER'S GEOTECHNICAL ENGINEER. FILL MATERIAL SHALL BE PLACED IN UNIFORM LAYERS NOT TO EXCEED TWELVE INCHES (12) THICK. DETERMINE THE MAXIMUM LIFT THICKNESS BASED ON THE ABILITY OF THE COMPACTING OPERATION AND EQUIPMENT USED TO MEET THE REQUIRED DENSITY. EACH LAYER OF MATERIAL SHALL BE COMPACTED TO A MINIMUM 95% DENSITY TESTED FOR DENSITY AND MOISTURE IN ACCORDANCE TEX-114-E, TEX-115-E. THE NUMBER AND LOCATION OF REQUIRED TESTS SHALL BE DETERMINED BY THE CITY OF NEW BRAUNFELS STREET INSPECTOR. AT A MINIMUM TESTS SHALL BE TAKEN EVERY 200 FT FOR EACH LIFT AND EVERY OTHER SERVICE LINE. UPON COMPLETION OF TESTING THE GEOTECHNICAL ENGINEER SHALL PROVIDE THE CITY OF NEW BRAUNFELS STREET INSPECTOR WITH ALL TESTING DOCUMENTATION AND A CERTIFICATION STATING THAT THE PLACEMENT OF FILL MATERIAL HAS BEEN COMPLETED IN ACCORDANCE WITH THE PLANS. ADDITIONAL DENSITY TESTS MAY BE REQUESTED BY THE CITY OF NEW BRAUNFELS INSPECTOR.

**GENERAL NOTES**

- FIRE HYDRANT SHALL BE LOCATED BEHIND SIDEWALK IN ACCORDANCE WITH THE FIRE HYDRANT INSTALLATION DETAIL DD-534-01.
- CONTRACTOR TO FIELD VERIFY EXACT LOCATIONS OF ALL EXISTING UTILITIES HORIZONTALLY AND VERTICALLY PRIOR TO CONSTRUCTION.
- ALL VALVES SHALL READ "OPEN RIGHT".
- ALL FIRE HYDRANTS SHALL BE PAINTED APPROPRIATE NBU COLORS.
- FIRE HYDRANTS AND VALVE BOXES TO BE RAISED TO THE PROPOSED TOP OF PAVEMENT OR GROUND ELEVATION.
- ALL WATER PIPE TO BE C-900, DR-18, CLASS 150 UNLESS OTHERWISE NOTED.
- CONTRACTOR SHALL VERIFY GRAVITY INVERTS PRIOR TO CONSTRUCTION AND NOTIFY CIVIL ENGINEER IN WRITING OF ANY DISCREPANCIES.
- CONTRACTOR SHALL BE RESPONSIBLE FOR MEETING 95% COMPACTION ON ALL UTILITY TRENCH BACKFILL AND PAYING FOR THE TESTS TO BE PERFORMED BY A THIRD PARTY. COMPACTION TESTS WILL BE DONE AT ONE LOCATION POINT RANDOMLY SELECTED OR AS INDICATED BY THE SAWS INSPECTOR/TEST ADMINISTER, PER EACH 12-INCH LOOSE LIFT PER 400 LINEAR FEET AT A MINIMUM. THIS PROJECT WILL NOT BE ACCEPTED AND FINALIZED BY SAWS WITHOUT THIS REQUIREMENT BEING MET AND VERIFIED BY PROVIDING ALL NECESSARY DOCUMENTED TEST RESULTS.
- CONTRACTOR TO REFERENCE MOST CURRENT NBU DETAILS & SPECIFICATIONS. FOR SEWER MANHOLES REFERENCE NBU STANDARD SPECIFICATION ITEM NO. 852.
- CONTRACTOR SHALL BE RESPONSIBLE FOR MEETING NBU STANDARD SPECIFICATION 804 FOR EXCAVATION, TRENCHING AND BACKFILLING REQUIREMENTS AND STANDARD SPECIFICATION 812 FOR WATER/SEWER SEPARATION REQUIREMENTS.

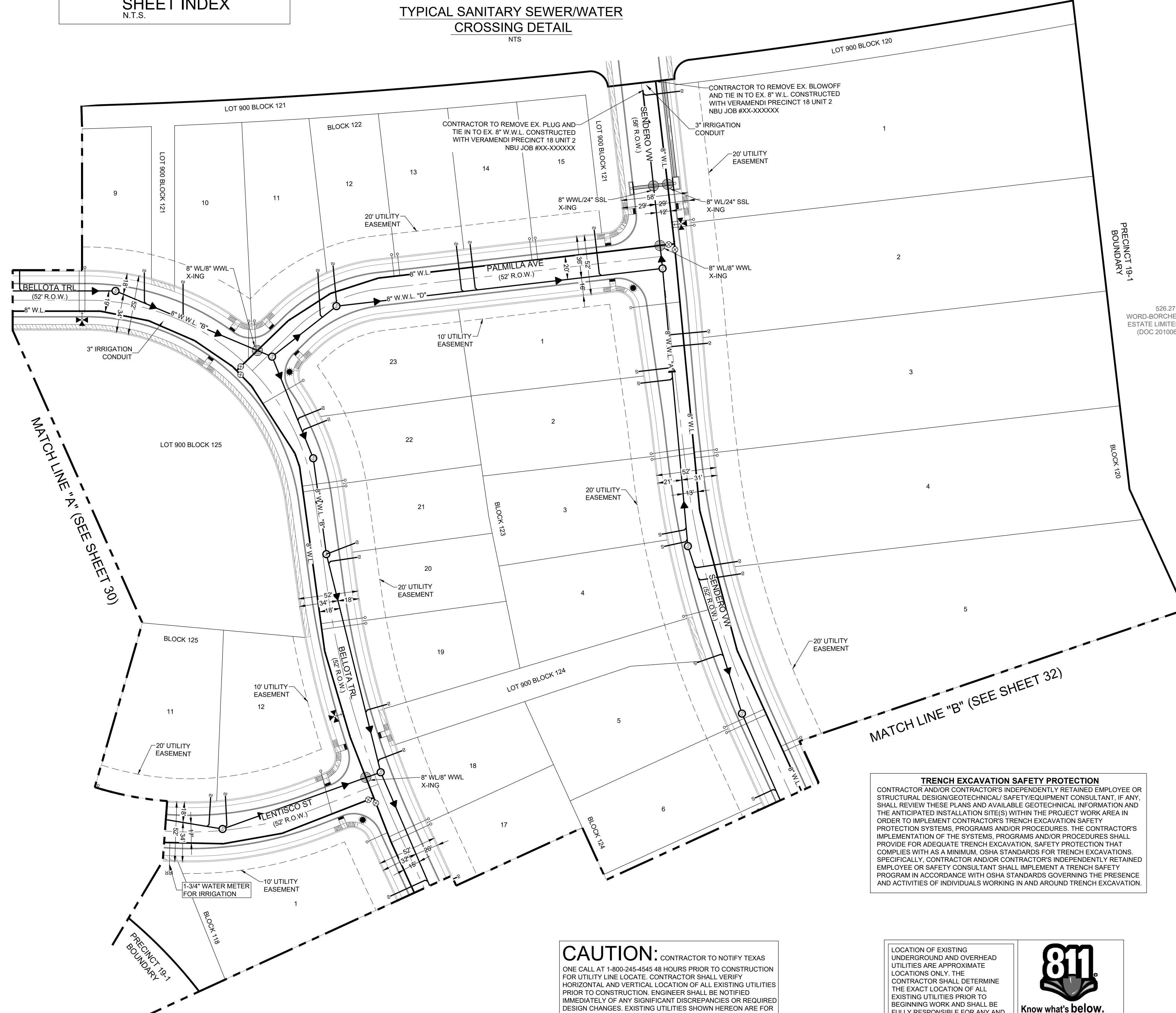

**LEGEND**

PROPOSED	EXISTING	
		SANITARY SEWER MANHOLE
		SANITARY SEWER LINE
		SANITARY SEWER LATERAL
		CLEAN OUT (INSTALL BY HOME BUILDER)
		WATER VALVE
		SINGLE WATER SERVICE
		DUAL WATER SERVICE
		FIRE HYDRANT
		PROPOSED SIDEWALK BY DEVELOPER
		WATER METER
		GAS VALVE
		GAS LINE
		STORM SEWER MANHOLE
		CURB INLET
		POWER POLE
		STREET LIGHT (100 WATT LED)
		STREET LIGHT (250 WATT LED)
		GUY WIRE
		OVERHEAD ELECTRIC
		BENCHMARK
		TOP OF MANHOLE
		EXISTING
		P.U.E.
		EASEMENT
		ESMT
		VOL
		PG

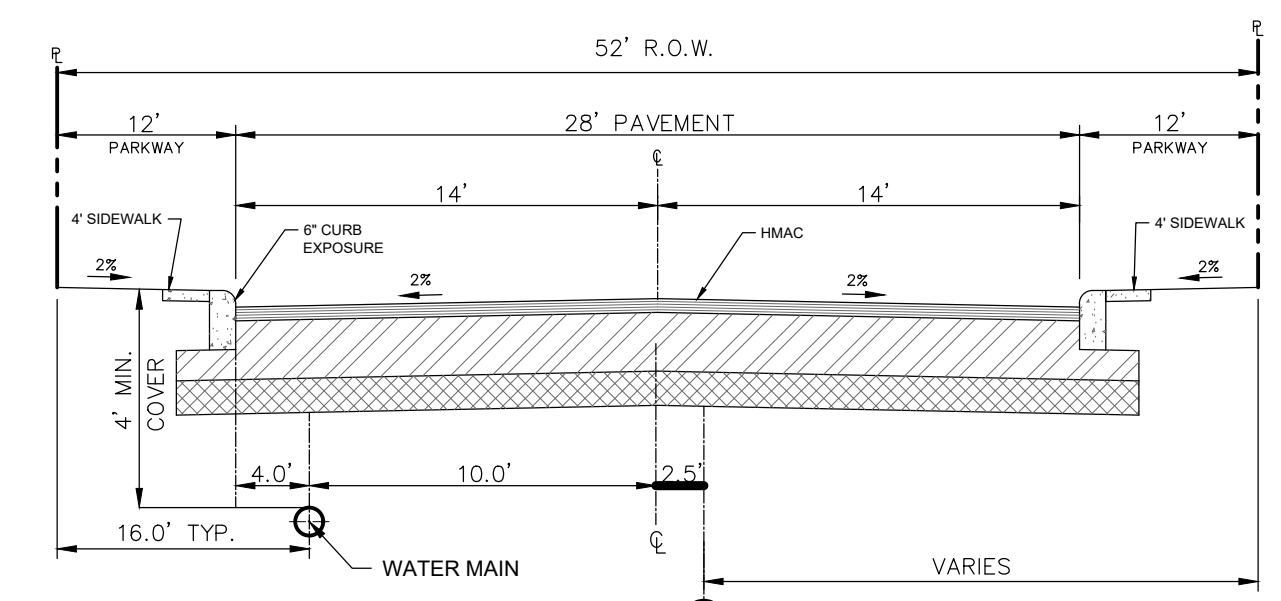

**STANDARD 52' ROW STREET SECTION (UTILITIES)**  
N.T.S.

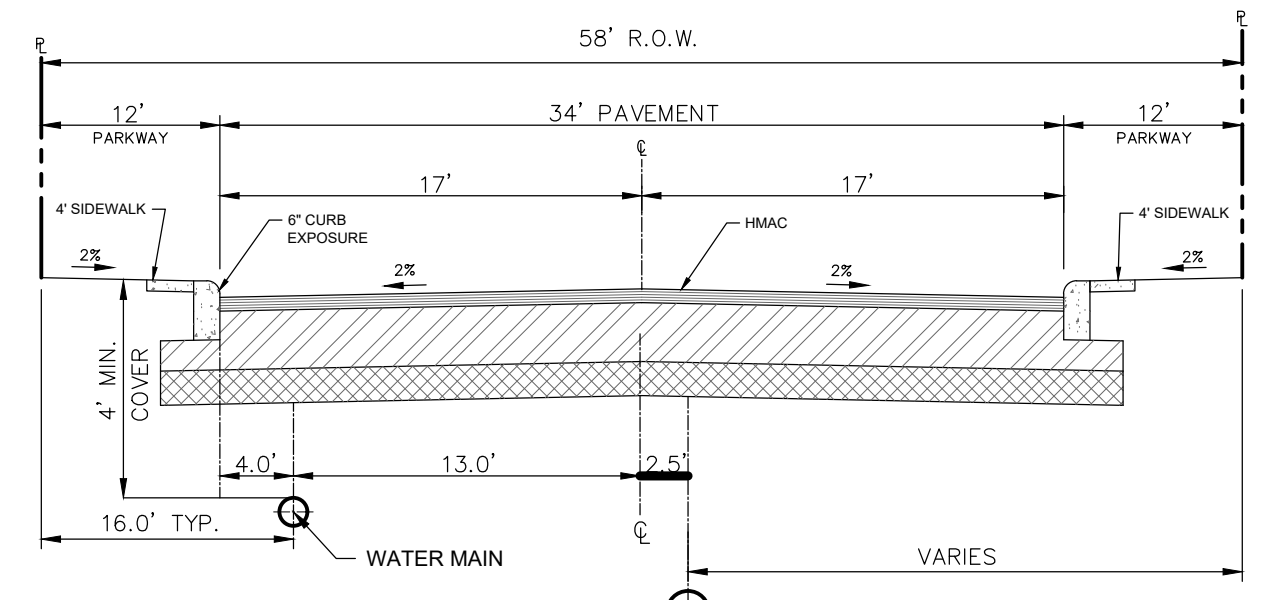

**STANDARD 58' ROW STREET SECTION (UTILITIES)**  
N.T.S.

**TRENCH EXCAVATION SAFETY PROTECTION**  
CONTRACTOR AND/OR CONTRACTOR'S INDEPENDENTLY RETAINED EMPLOYEE OR STRUCTURAL DESIGN/GEOTECHNICAL/SAFETY/EQUIPMENT CONSULTANT, IF ANY, SHALL REVIEW THESE PLANS AND AVAILABLE GEOTECHNICAL INFORMATION AND THE ANTICIPATED INSTALLATION SITE(S) WITHIN THE PROJECT WORK AREA IN ORDER TO IMPLEMENT CONTRACTOR'S TRENCH EXCAVATION SAFETY PROTECTION SYSTEMS, PROGRAMS AND/OR PROCEDURES. THE CONTRACTOR'S IMPLEMENTATION OF THE SYSTEMS, PROGRAMS AND/OR PROCEDURES SHALL PROVIDE FOR ADEQUATE TRENCH EXCAVATION, SAFETY PROTECTION THAT COMPLIES WITH AS A MINIMUM, OSHA STANDARDS FOR TRENCH EXCAVATIONS. SPECIFICALLY, CONTRACTOR AND/OR CONTRACTOR'S INDEPENDENTLY RETAINED EMPLOYEE OR SAFETY CONSULTANT SHALL IMPLEMENT A TRENCH SAFETY PROGRAM IN ACCORDANCE WITH OSHA STANDARDS GOVERNING THE PRESENCE AND ACTIVITIES OF INDIVIDUALS WORKING IN AND AROUND TRENCH EXCAVATION.

**CAUTION:** CONTRACTOR TO NOTIFY TEXAS ONE CALL AT 1-800-245-4545 48 HOURS PRIOR TO CONSTRUCTION FOR UTILITY LINE LOCATE. CONTRACTOR SHALL VERIFY HORIZONTAL AND VERTICAL LOCATION OF ALL EXISTING UTILITIES PRIOR TO CONSTRUCTION. ENGINEER SHALL BE NOTIFIED IMMEDIATELY OF ANY SIGNIFICANT DISCREPANCIES OR REQUIRED DESIGN CHANGES. EXISTING UTILITIES SHOWN HEREON ARE FOR INFORMATIONAL PURPOSES ONLY. ENGINEER ASSUMES NO RESPONSIBILITY FOR THE ACCURACY OF THIS INFORMATION.



**VERAMENDI PRECINCT 19 UNIT 1**  
UTILITY LAYOUT (SHEET 2 OF 3)

DATE: 11/29/2023  
DESIGNED BY: NG  
DRAWN BY: TM  
CHECKED BY: PF  
DRAWING NAME: ch\_Utility Layout.dwg

PRISCILLA G. FLORES  
109874  
LICENSED PROFESSIONAL ENGINEER

**LJA Engineering, Inc.**  
9830 Calomrade Blvd  
Suite 300  
San Antonio, Texas 78230  
Phone 210.503.2700  
LJA.COM  
TBP# No. F-1386

JOB NUMBER: SA3856.0401  
SHEET NO. 31 OF 61 SHEETS

K:\ASB\ASB\_ACSA\_Progress\0400\_Veramendi\_Precinct\_19-1\400\_Site\_Development\Plans\19-1\Sheet\ch\_Utility Layout.dwg  
Last Modified: Nov 29, 2023 10:23:21 AM  
Plot Date/Time: Nov 29, 2023 10:23:21 AM

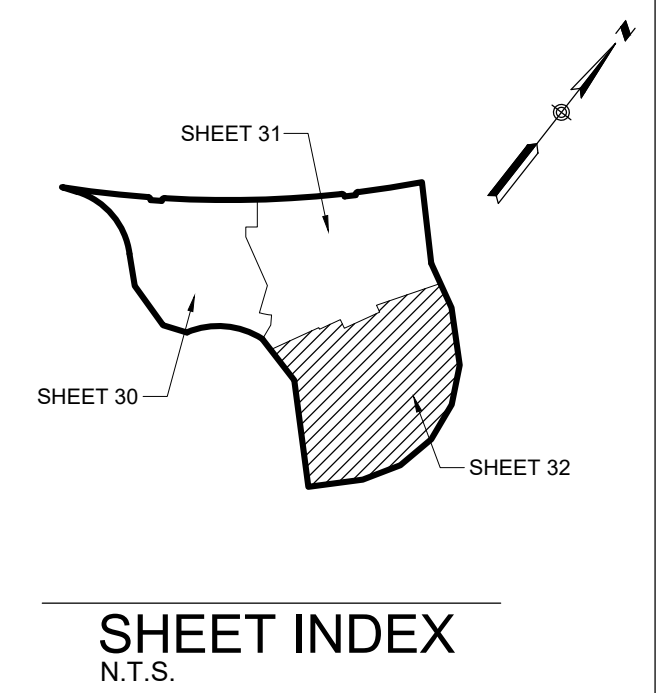
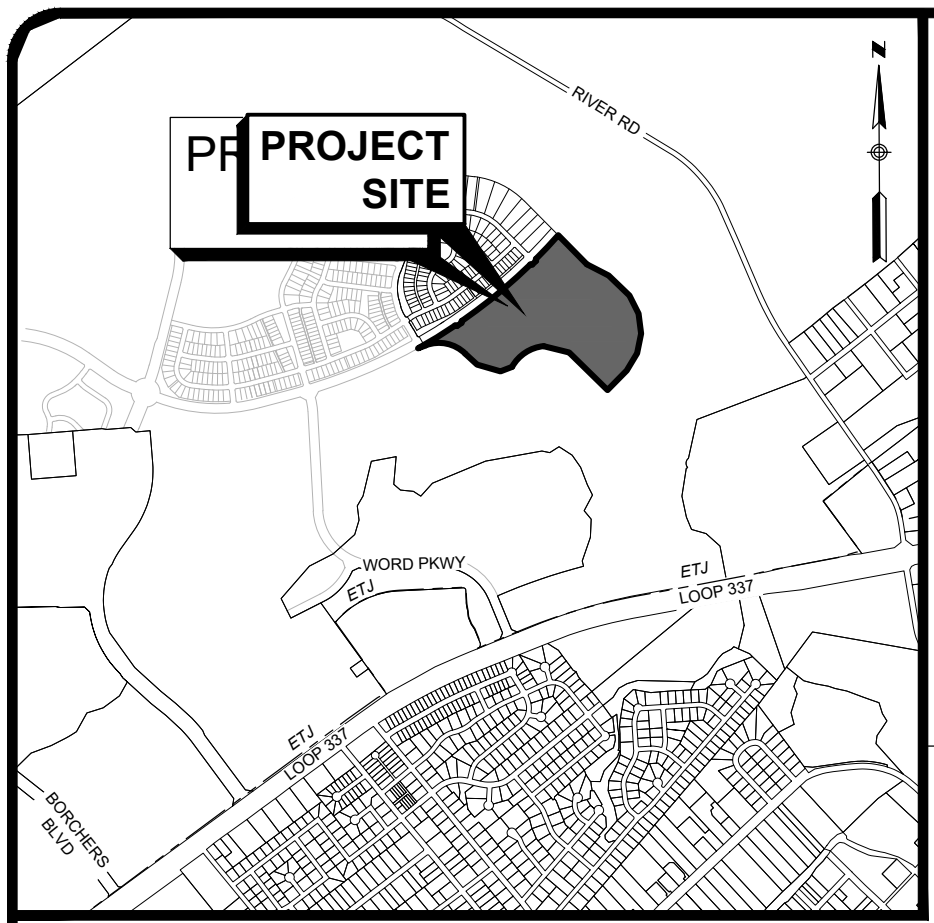

**LOCATION MAP**  
SCALE: 1" = 2000'

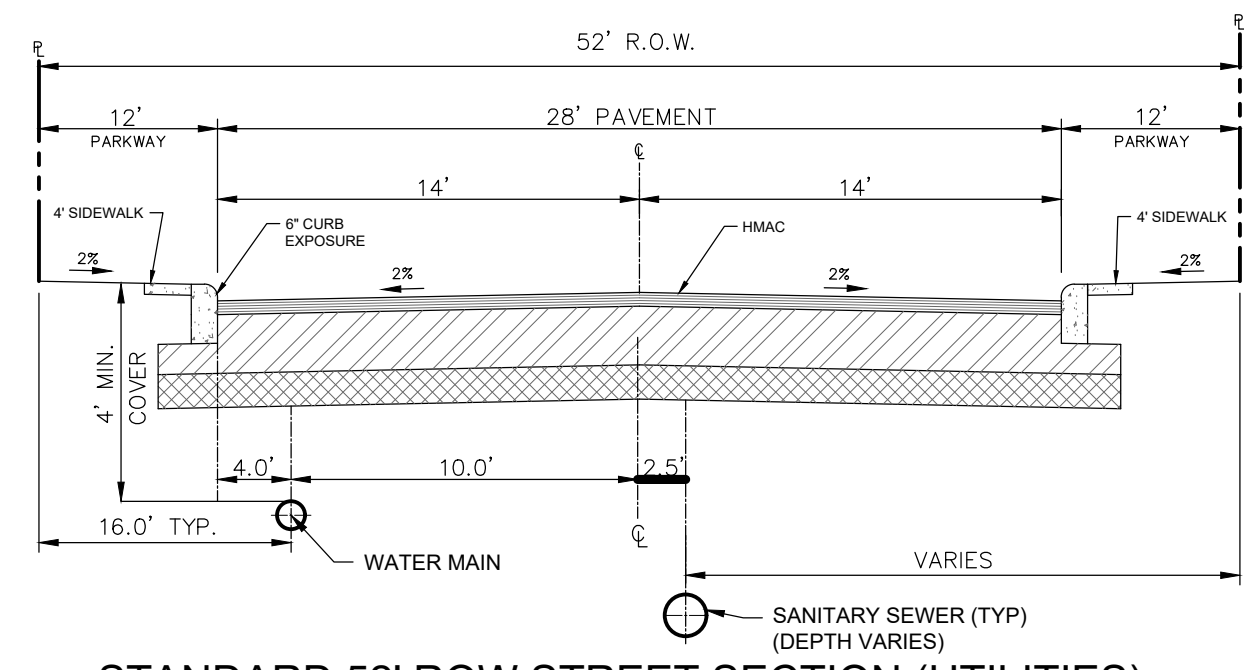

**STANDARD 52' ROW STREET SECTION (UTILITIES)**  
N.T.S.

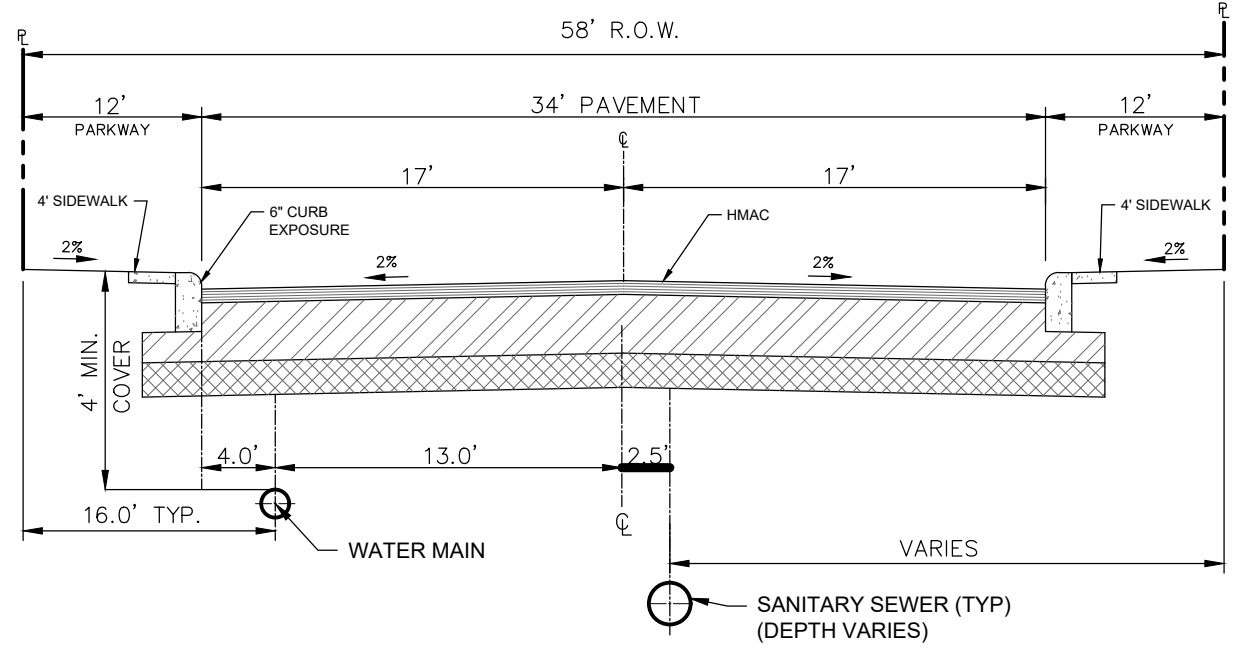

**STANDARD 58' ROW STREET SECTION (UTILITIES)**  
N.T.S.

**CITY OF NEW BRAUNFELS NOTES**

- NO VALVES, HYDRANTS, ETC. SHALL BE CONSTRUCTED WITHIN CURBS, SIDEWALKS, OR DRIVEWAYS.
- ALL UTILITIES TO BE CONSTRUCTED PRIOR TO STREETS.
- THIS PROJECT INCLUDES UTILITY INSTALLATIONS GREATER THAN 5-FOOT IN DEPTH. DEEP TRENCHES POSE COMPACTION TESTING AND CONSTRUCTION CHALLENGES AND CITY METHODS FOR TESTING AND COMPACTION MAY NOT BE ACHIEVABLE. A UTILITY COMPACTION PLAN WILL BE REQUIRED AND MUST BE SUBMITTED FOR APPROVAL TO CITY PRIOR TO UTILITY INSTALLATION.
- UTILITY TRENCH COMPACTION ALL UTILITY TRENCH COMPACTION TESTS WITHIN THE STREET PAVEMENT/SIDEWALK SECTION SHALL BE THE RESPONSIBILITY OF THE DEVELOPER'S GEOTECHNICAL ENGINEER. FILL MATERIAL SHALL BE PLACED IN UNIFORM LAYERS NOT TO EXCEED TWELVE INCHES (12) THICK. DETERMINE THE MAXIMUM LIFT THICKNESS BASED ON THE ABILITY OF THE COMPACTION OPERATION AND EQUIPMENT USED TO MEET THE REQUIRED DENSITY. EACH LAYER OF MATERIAL SHALL BE COMPACTED TO A MINIMUM 95% DENSITY TESTED FOR DENSITY AND MOISTURE IN ACCORDANCE TEX-114-E, TEX-115-E. THE NUMBER AND LOCATION OF REQUIRED TESTS SHALL BE DETERMINED BY THE CITY OF NEW BRAUNFELS STREET INSPECTOR. AT A MINIMUM TESTS SHALL BE TAKEN EVERY 200 FT FOR EACH LIFT AND EVERY OTHER SERVICE LINE. UPON COMPLETION OF TESTING THE GEOTECHNICAL ENGINEER SHALL PROVIDE THE CITY OF NEW BRAUNFELS STREET INSPECTOR WITH ALL TESTING DOCUMENTATION AND A CERTIFICATION STATING THAT THE PLACEMENT OF FILL MATERIAL HAS BEEN COMPLETED IN ACCORDANCE WITH THE PLANS. ADDITIONAL DENSITY TESTS MAY BE REQUESTED BY THE CITY OF NEW BRAUNFELS INSPECTOR.

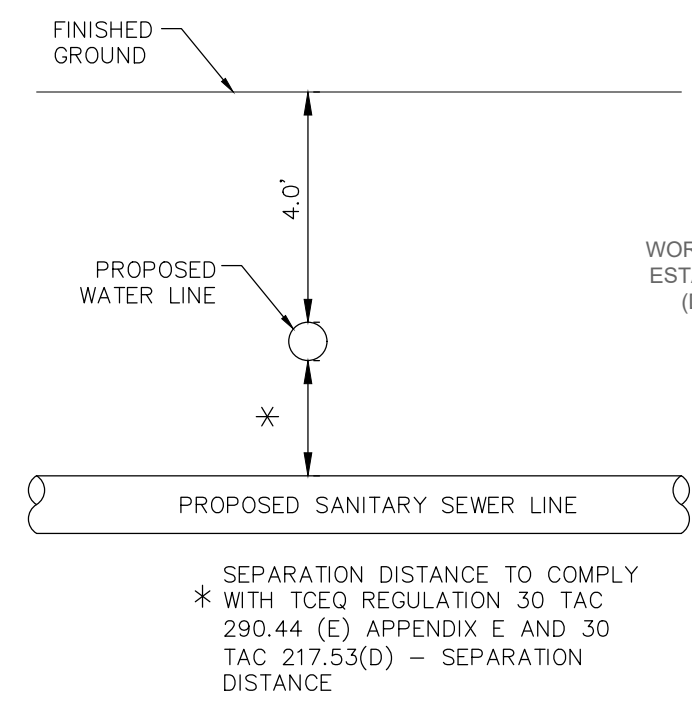

**TYPICAL SANITARY SEWER/WATER CROSSING DETAIL**  
N.T.S.

**GENERAL NOTES**

- FIRE HYDRANT SHALL BE LOCATED BEHIND SIDEWALK IN ACCORDANCE WITH THE FIRE HYDRANT INSTALLATION DETAIL DD-834-01.
- CONTRACTOR TO FIELD VERIFY EXACT LOCATIONS OF ALL EXISTING UTILITIES HORIZONTALLY AND VERTICALLY PRIOR TO CONSTRUCTION.
- ALL VALVES SHALL READ "OPEN RIGHT".
- ALL FIRE HYDRANTS SHALL BE PAINTED APPROPRIATE NBU COLORS.
- FIRE HYDRANTS AND VALVE BOXES TO BE RAISED TO THE PROPOSED TOP OF PAVEMENT OR GROUND ELEVATION.
- ALL WATER PIPE TO BE C-900, DR-18, CLASS 150 UNLESS OTHERWISE NOTED.
- CONTRACTOR SHALL VERIFY GRAVITY INVERTS PRIOR TO CONSTRUCTION AND NOTIFY CIVIL ENGINEER IN WRITING OF ANY DISCREPANCIES.
- CONTRACTOR SHALL BE RESPONSIBLE FOR MEETING 95% COMPACTION ON ALL UTILITY TRENCH BACKFILL AND PAYING FOR THE TESTS TO BE PERFORMED BY A THIRD PARTY. COMPACTION TESTS WILL BE DONE AT ONE LOCATION POINT RANDOMLY SELECTED OR AS INDICATED BY THE SAWS INSPECTOR/TEST ADMINISTRATOR. PER EACH 12-INCH LOOSE LIFT PER 400 LINEAR FEET AT A MINIMUM. THIS PROJECT WILL NOT BE ACCEPTED AND FINALIZED BY SAWS WITHOUT THIS REQUIREMENT BEING MET AND VERIFIED BY PROVIDING ALL NECESSARY DOCUMENTED TEST RESULTS.
- CONTRACTOR TO REFERENCE MOST CURRENT NBU DETAILS & SPECIFICATIONS. FOR SEWER MANHOLES REFERENCE NBU STANDARD SPECIFICATION ITEM NO. 852.
- CONTRACTOR SHALL BE RESPONSIBLE FOR MEETING NBU STANDARD SPECIFICATION 804 FOR EXCAVATION, TRENCHING AND BACKFILLING REQUIREMENTS AND STANDARD SPECIFICATION 812 FOR WATER/SEWER SEPARATION REQUIREMENTS.

**CAUTION:** CONTRACTOR TO NOTIFY TEXAS ONE CALL AT 1-800-245-4545 48 HOURS PRIOR TO CONSTRUCTION FOR UTILITY LINE LOCATE. CONTRACTOR SHALL VERIFY HORIZONTAL AND VERTICAL LOCATION OF ALL EXISTING UTILITIES PRIOR TO CONSTRUCTION. ENGINEER SHALL BE NOTIFIED IMMEDIATELY OF ANY SIGNIFICANT DISCREPANCIES OR REQUIRED DESIGN CHANGES. EXISTING UTILITIES SHOWN HEREON ARE FOR INFORMATIONAL PURPOSES ONLY. ENGINEER ASSUMES NO RESPONSIBILITY FOR THE ACCURACY OF THIS INFORMATION.

**LEGEND**

PROPOSED	EXISTING	
		SANITARY SEWER MANHOLE
		SANITARY SEWER LINE
		WATER LINE
		SANITARY SEWER LATERAL
		CLEAN OUT (INSTALL BY HOME BUILDER)
		WATER VALVE
		SINGLE WATER SERVICE
		DUAL WATER SERVICE
		FIRE HYDRANT
		PROPOSED SIDEWALK BY DEVELOPER
		WATER METER
		GAS VALVE
		GAS LINE
		STORM SEWER MANHOLE
		CURB INLET
		POWER POLE
		STREET LIGHT (100 WATT LED)
		STREET LIGHT (250 WATT LED)
		GUY WIRE
		OVERHEAD ELECTRIC
		BENCHMARK
		TOP OF MANHOLE
		EXISTING
		P.U.E.
		EASEMENT
		VOLUME
		PAGE

K:\GIS\ASAP\Projects\4440\_Veramendi Precinct 19-1\4440\_Site Development\Plans\NBU\31-Shrubs\31-Utility Layout.dwg  
 User: jgarcia Date: 11/29/2023 10:23:21 AM  
 Plot: 11/29/2023 10:23:21 AM

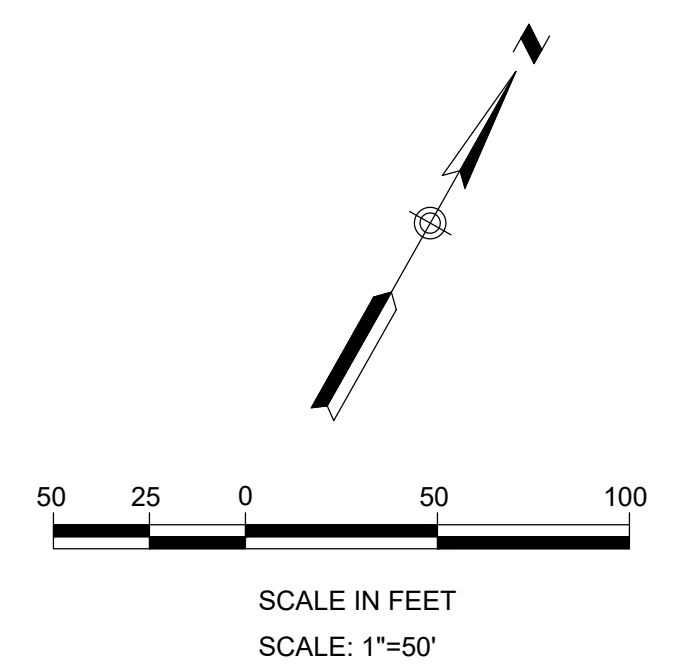
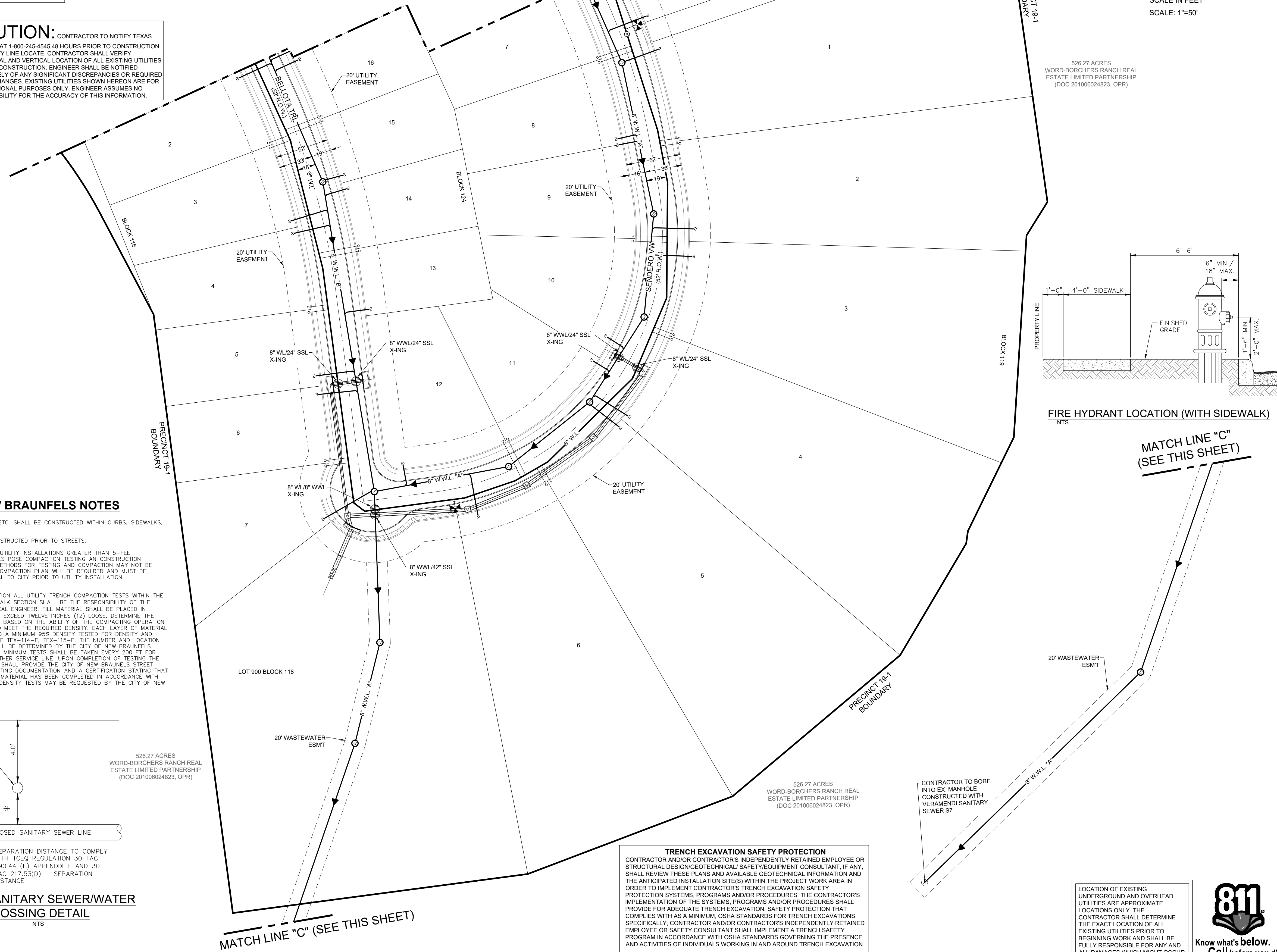

526.27 ACRES  
WORD-BORCHERS RANCH REAL ESTATE LIMITED PARTNERSHIP  
(DOC 201006024823, OPR)

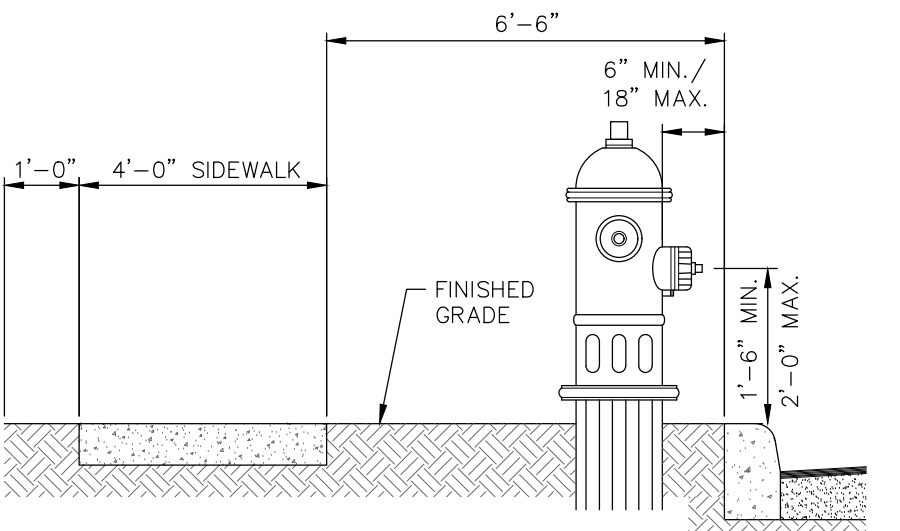

**FIRE HYDRANT LOCATION (WITH SIDEWALK)**  
N.T.S.

**TRENCH EXCAVATION SAFETY PROTECTION**  
CONTRACTOR AND/OR CONTRACTOR'S INDEPENDENTLY RETAINED EMPLOYEE OR STRUCTURAL DESIGN/GEOTECHNICAL/SAFETY/EQUIPMENT CONSULTANT, IF ANY, SHALL REVIEW THESE PLANS AND AVAILABLE GEOTECHNICAL INFORMATION AND THE ANTICIPATED INSTALLATION SITE(S) WITHIN THE PROJECT WORK AREA IN ORDER TO IMPLEMENT CONTRACTOR'S TRENCH EXCAVATION SAFETY PROTECTION SYSTEMS, PROGRAMS AND/OR PROCEDURES. THE CONTRACTOR'S IMPLEMENTATION OF THE SYSTEMS, PROGRAMS AND/OR PROCEDURES SHALL PROVIDE FOR ADEQUATE TRENCH EXCAVATION, SAFETY PROTECTION THAT COMPLIES WITH AS A MINIMUM, OSHA STANDARDS FOR TRENCH EXCAVATIONS. SPECIFICALLY, CONTRACTOR AND/OR CONTRACTOR'S INDEPENDENTLY RETAINED EMPLOYEE OR SAFETY CONSULTANT SHALL IMPLEMENT A TRENCH SAFETY PROGRAM IN ACCORDANCE WITH OSHA STANDARDS GOVERNING THE PRESENCE AND ACTIVITIES OF INDIVIDUALS WORKING IN AND AROUND TRENCH EXCAVATION.

LOCATION OF EXISTING UNDERGROUND AND OVERHEAD UTILITIES ARE APPROXIMATE LOCATIONS ONLY. THE CONTRACTOR SHALL DETERMINE THE EXACT LOCATION OF ALL EXISTING UTILITIES PRIOR TO BEGINNING WORK AND SHALL BE FULLY RESPONSIBLE FOR ANY AND ALL DAMAGES WHICH MIGHT OCCUR.



**VERAMENDI PRECINCT 19 UNIT 1**  
 UTILITY LAYOUT (SHEET 3 OF 3)

NO.	REVISIONS	DESCRIPTION	DATE	BY

DATE: 11/29/2023  
 DESIGNED BY: NG  
 DRAWN BY: TM  
 CHECKED BY: PF  
 DRAWING NAME: sh\_Utility Layout.dwg

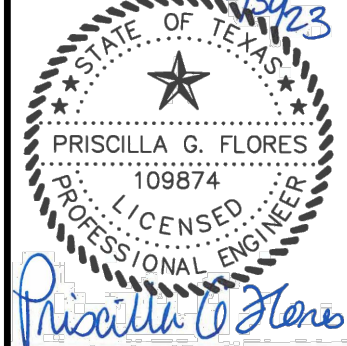

**LJA Engineering, Inc.**  
 Phone 210.603.2700  
 Suite 300 LJA.COM  
 San Antonio, Texas 78230  
 TBPE No. F-1386

JOB NUMBER: SA3856.0401  
 SHEET NO. **32** OF 61 SHEETS

FOR PERMIT

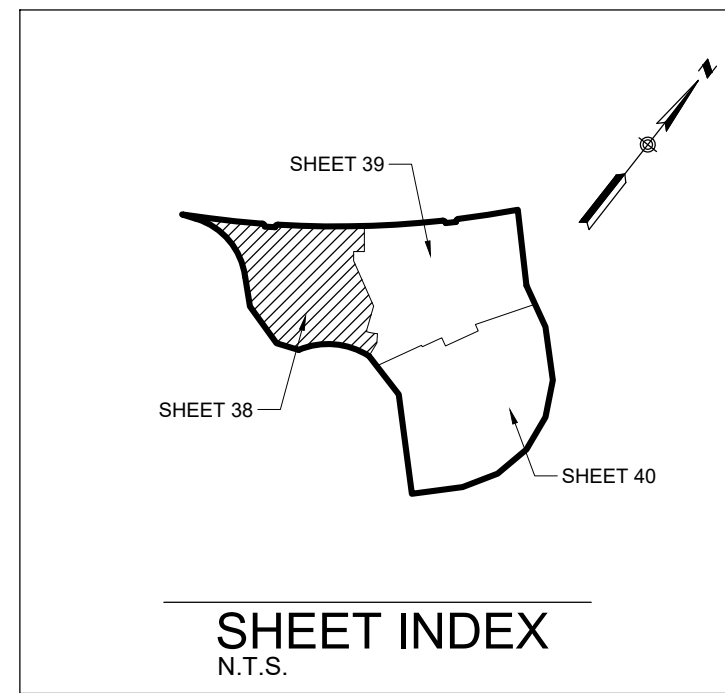
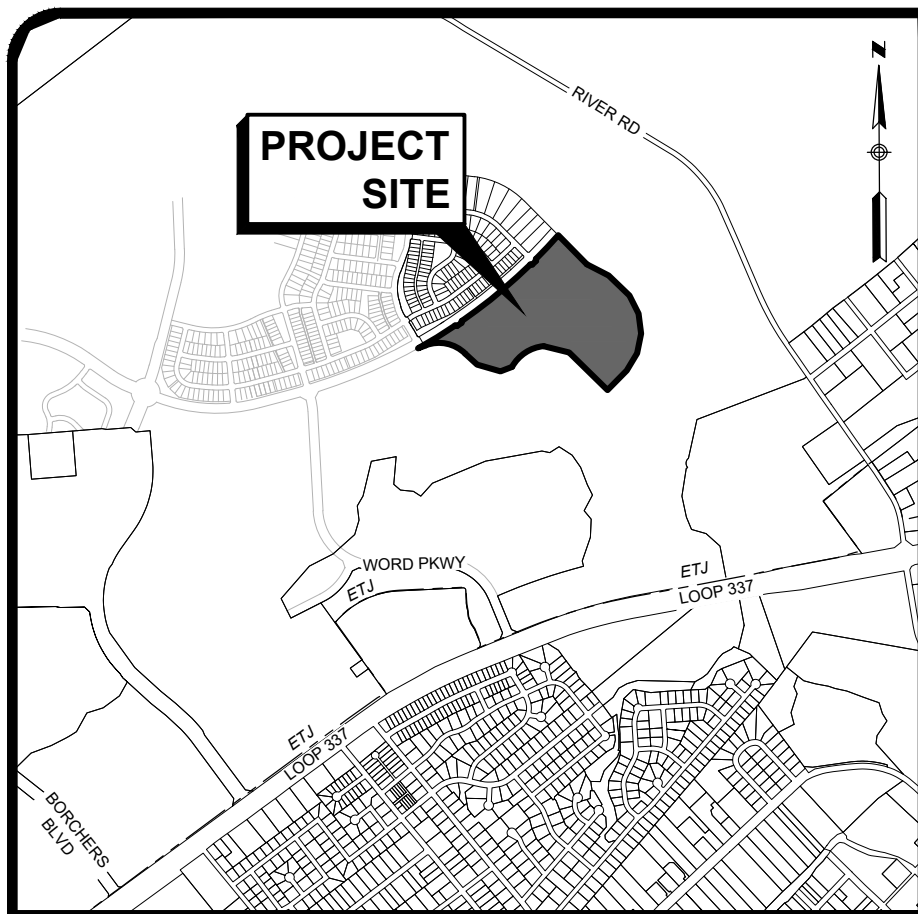

LOCATION MAP  
SCALE: 1" = 2000'

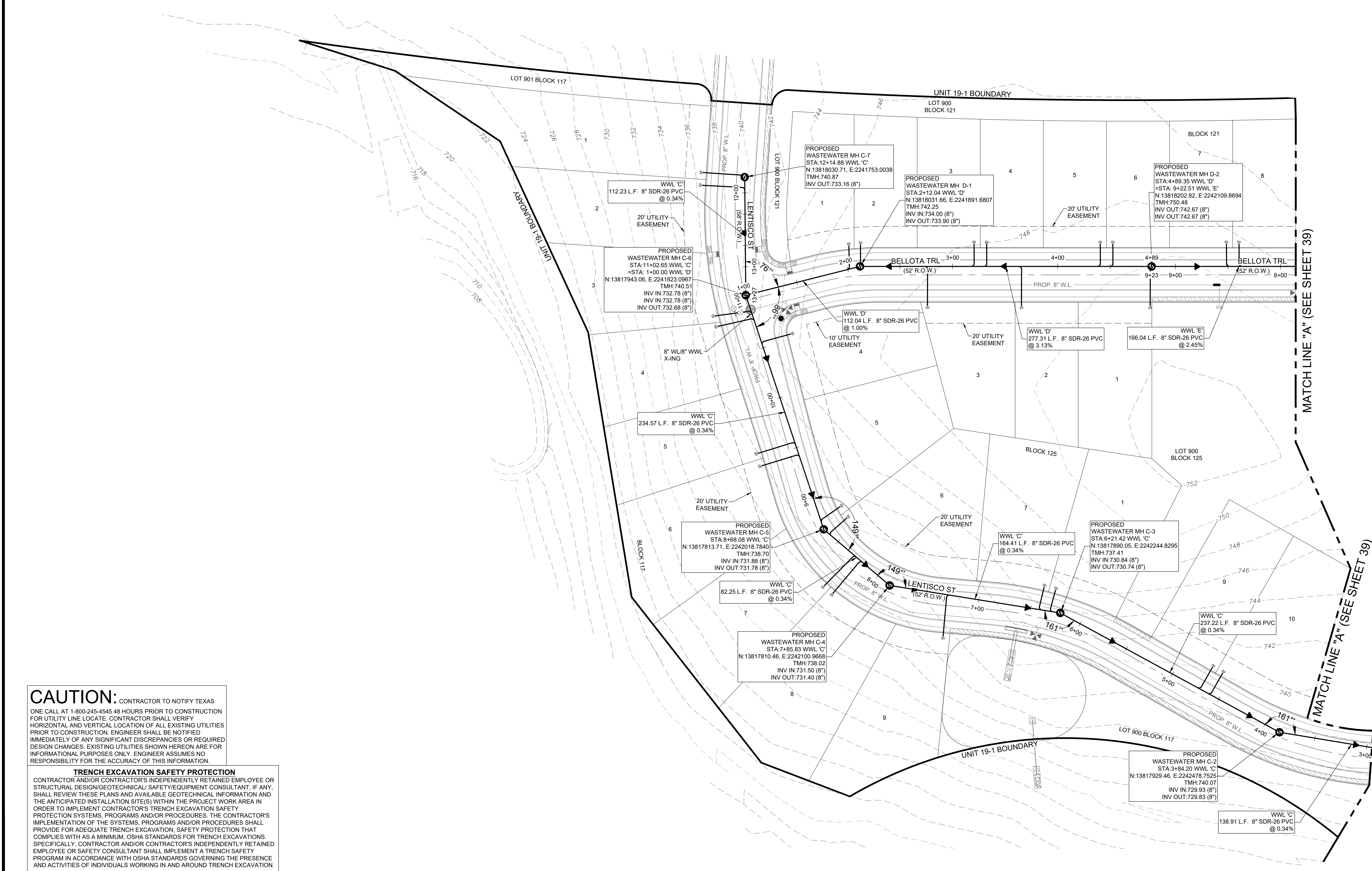
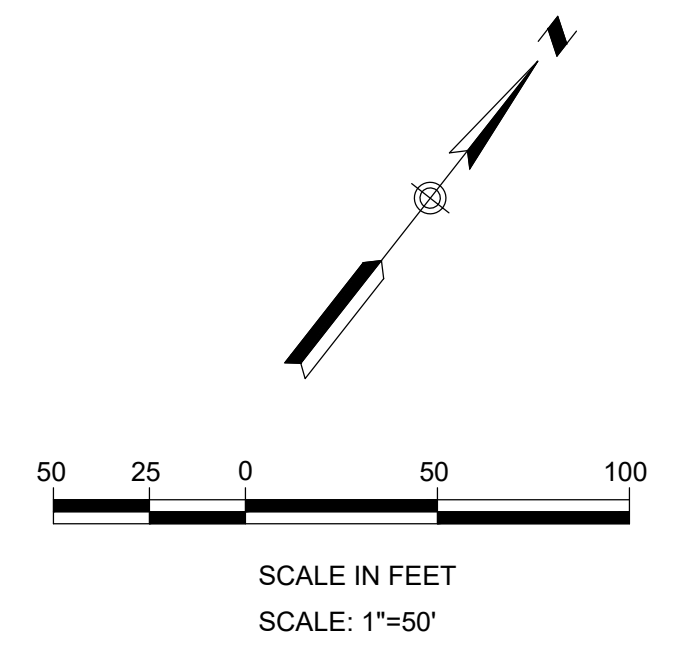

**LEGEND**

PROPOSED	EXISTING	DESCRIPTION
		SANITARY SEWER MANHOLE
		SANITARY SEWER LINE
		WATER LINE
		SANITARY SEWER LATERAL
		CLEAN OUT (INSTALL BY HOME BUILDER)
		WATER VALVE
		SINGLE WATER SERVICE
		DUAL WATER SERVICE
		FIRE HYDRANT
		PROPOSED SIDEWALK BY DEVELOPER
		WATER METER
		GAS VALVE
		GAS LINE
		STORM SEWER MANHOLE
		CURB INLET
		POWER POLE
		STREET LIGHT (100 WATT LED)
		STREET LIGHT (250 WATT LED)
		GUY WIRE
		OVERHEAD ELECTRIC
		BENCHMARK
		TOP OF MANHOLE
		EXISTING PUBLIC UTILITY EASEMENT
		EASEMENT
		VOLUME
		PAGE

- NOTES:**
- CONTRACTOR TO FIELD VERIFY EXACT LOCATION OF ALL EXISTING UTILITIES HORIZONTALLY AND VERTICALLY PRIOR TO CONSTRUCTION.
  - MANDREL TESTING WILL BE REQUIRED ON ALL FLEXIBLE GRAVITY WASTEWATER PIPE AS PRE TCEQ RULES.
  - ALL GRAVITY WASTEWATER LINES SHALL BE SDR-26 WWL ASTM D3034 UNLESS OTHERWISE NOTED.
  - CONTRACTOR TO FILL AND COMPACT TO 95% DENSITY IN FILL SECTIONS OVER WASTEWATER LINES. 2.0'(MIN.) COVER OVER WATER PRIOR TO CONSTRUCTION.
  - ALL SERVICES SHALL TERMINATE WITH A 2-WAY CLEANOUT.
  - ALL ON-SITE UTILITIES SHALL BE LOCATED UNDERGROUND UNLESS REQUIRED BY THE UTILITY TO BE OTHERWISE LOCATED (SECTION 25-2-1125).
  - WHERE THE MINIMUM 9 FOOT SEPARATION DISTANCE BETWEEN WASTEWATER LINES AND WATER LINES / MAINS CANNOT BE MAINTAINED, THE INSTALLATION OF WASTEWATER LINES SHALL BE IN STRICT ACCORDANCE WITH TCEQ. THE WASTEWATER LINE SHALL BE CONSTRUCTED OF CAST IRON, DUCTILE IRON OR PVC MEETING THE ASTM SPECIFICATION FOR BOTH PIPES AND JOINTS OF 150 PSI AND SHALL BE IN ACCORDANCE WITH 30 TAC § 217.53 (D) (3) (A) (I).

**CAUTION:** CONTRACTOR TO NOTIFY TEXAS ONE CALL AT 1-800-245-4545 48 HOURS PRIOR TO CONSTRUCTION FOR UTILITY LINE LOCATE. CONTRACTOR SHALL VERIFY HORIZONTAL AND VERTICAL LOCATION OF ALL EXISTING UTILITIES PRIOR TO CONSTRUCTION. ENGINEER SHALL BE NOTIFIED IMMEDIATELY OF ANY SIGNIFICANT DISCREPANCIES OR REQUIRED DESIGN CHANGES. EXISTING UTILITIES SHOWN HEREON ARE FOR INFORMATIONAL PURPOSES ONLY. ENGINEER ASSUMES NO RESPONSIBILITY FOR THE ACCURACY OF THIS INFORMATION.

**TRENCH EXCAVATION SAFETY PROTECTION**  
CONTRACTOR AND/OR CONTRACTOR'S INDEPENDENTLY RETAINED EMPLOYEE OR STRUCTURAL DESIGN/GEOTECHNICAL SAFETY/EQUIPMENT CONSULTANT, IF ANY, SHALL REVIEW THESE PLANS AND AVAILABLE GEOTECHNICAL INFORMATION AND THE ANTICIPATED INSTALLATION SITE(S) WITHIN THE PROJECT WORK AREA IN ORDER TO IMPLEMENT CONTRACTOR'S TRENCH EXCAVATION SAFETY PROTECTION SYSTEMS, PROGRAMS AND/OR PROCEDURES. THE CONTRACTOR'S IMPLEMENTATION OF THE SYSTEMS, PROGRAMS AND/OR PROCEDURES SHALL PROVIDE FOR ADEQUATE TRENCH EXCAVATION, SAFETY PROTECTION THAT COMPLIES WITH AS A MINIMUM, OSHA STANDARDS FOR TRENCH EXCAVATIONS. SPECIFICALLY, CONTRACTOR AND/OR CONTRACTOR'S INDEPENDENTLY RETAINED EMPLOYEE OR SAFETY CONSULTANT SHALL IMPLEMENT A TRENCH SAFETY PROGRAM IN ACCORDANCE WITH OSHA STANDARDS GOVERNING THE PRESENCE AND ACTIVITIES OF INDIVIDUALS WORKING IN AND AROUND TRENCH EXCAVATION.

LOCATION OF EXISTING UNDERGROUND AND OVERHEAD UTILITIES ARE APPROXIMATE LOCATIONS ONLY. THE CONTRACTOR SHALL DETERMINE THE EXACT LOCATION OF ALL EXISTING UTILITIES PRIOR TO BEGINNING WORK AND SHALL BE FULLY RESPONSIBLE FOR ANY AND ALL DAMAGES WHICH MIGHT OCCUR.



VERAMENDI PRECINCT 19 UNIT 1  
WASTEWATER LAYOUT (SHEET 1 OF 3)

NO.	REVISIONS	DESCRIPTION	DATE	BY

DATE: 11/28/2023  
DESIGNED BY: NG  
DRAWN BY: TM  
CHECKED BY: PF  
DRAWING NAME: Wastewater Layout.dwg

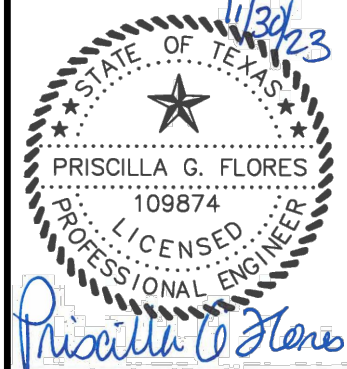

**LJA Engineering, Inc.**  
Phone 210.503.2700  
LJA.COM  
San Antonio, Texas 78230  
TBPE No. F-1386

JOB NUMBER: SA3856.0401  
SHEET NO. 38 OF 61 SHEETS

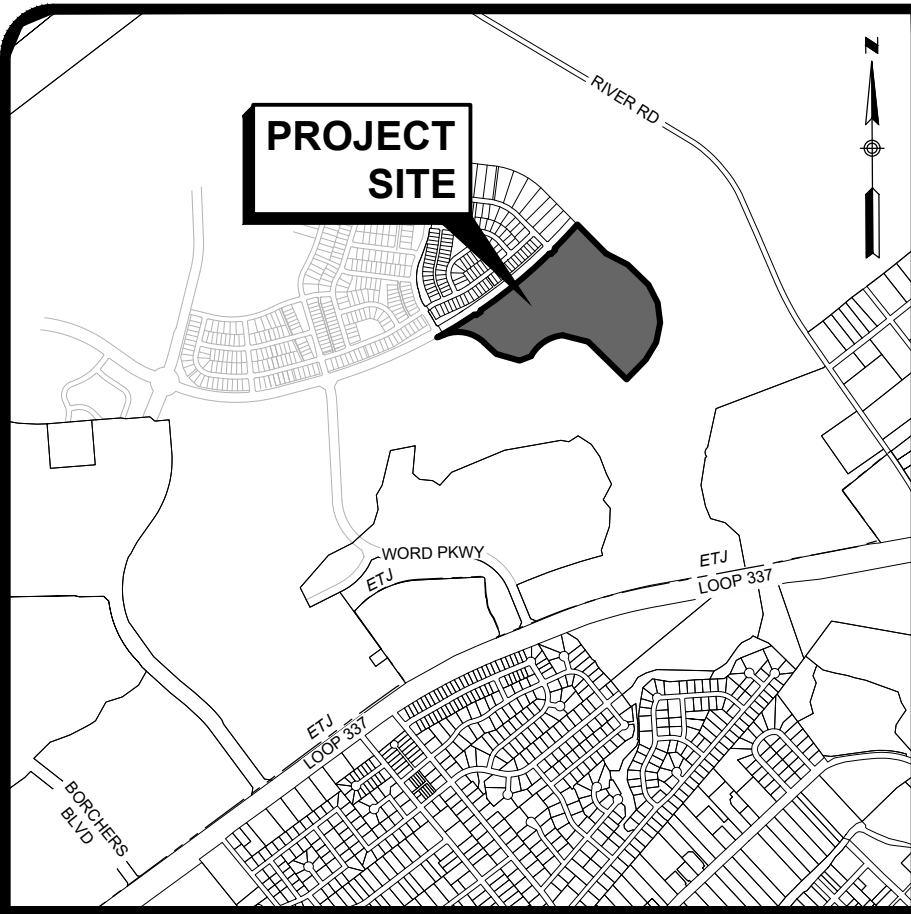

LOCATION MAP  
SCALE: 1" = 2000'

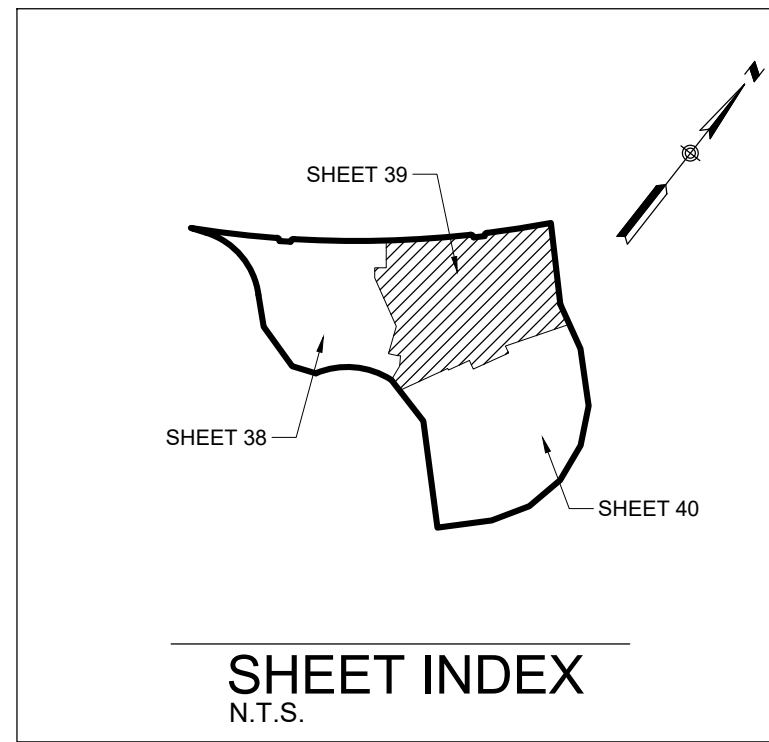

SHEET INDEX  
N.T.S.

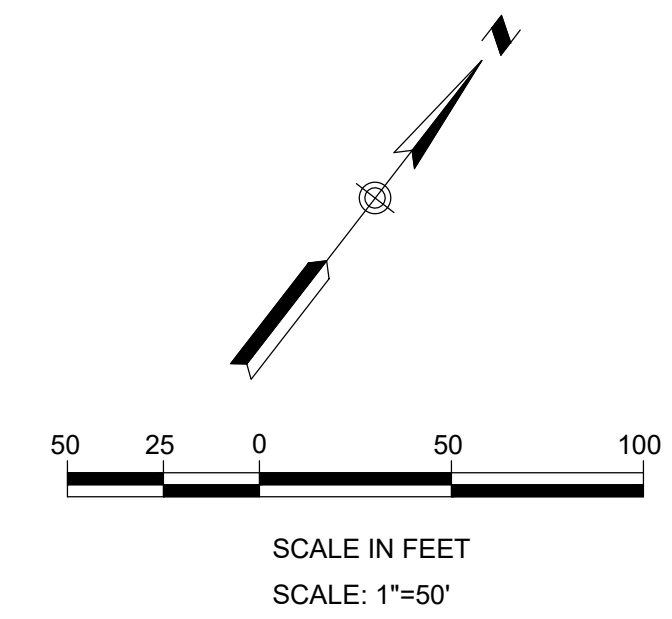

SCALE IN FEET  
SCALE: 1" = 50'

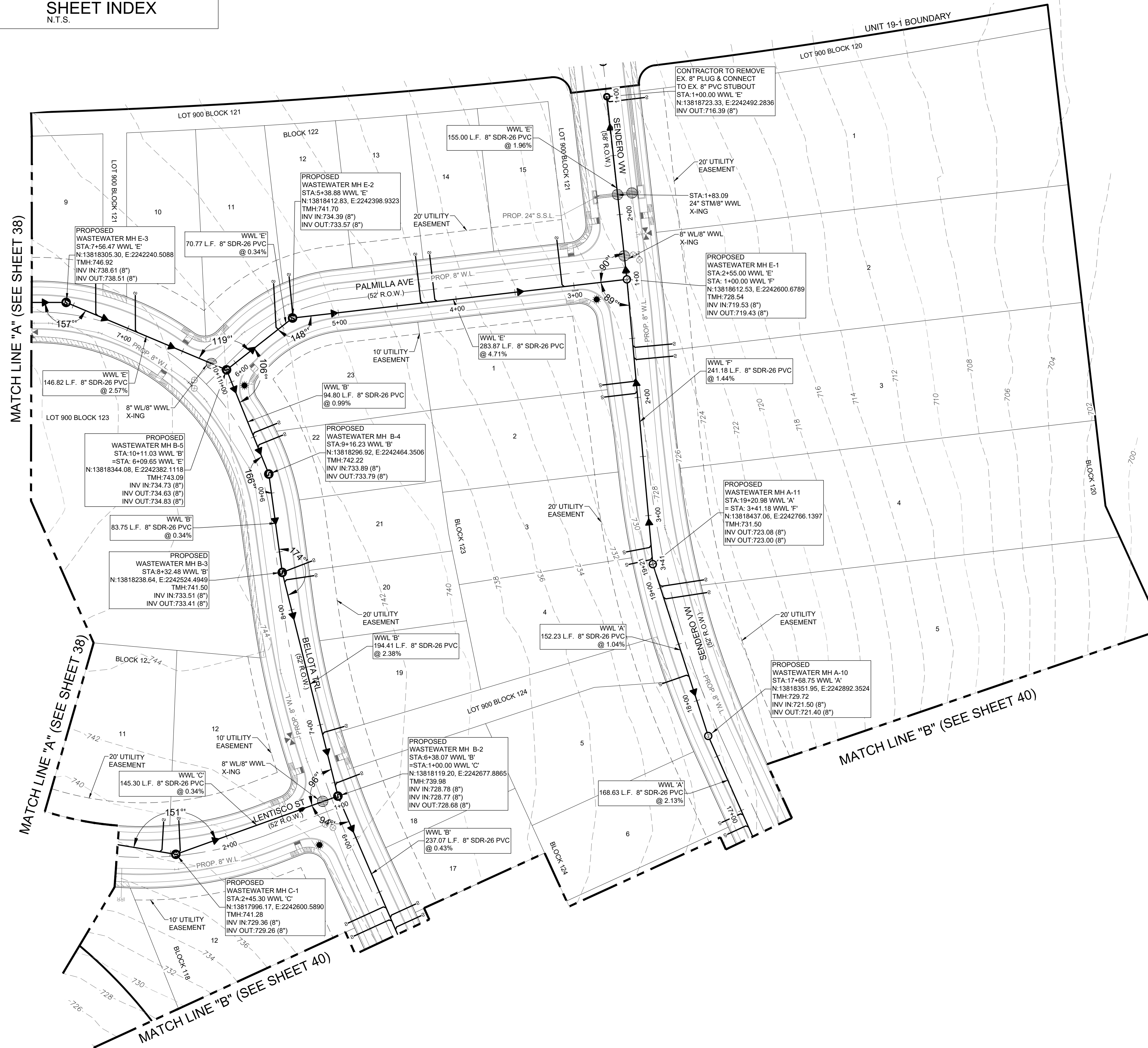

PROPOSED	EXISTING	
		SANITARY SEWER MANHOLE
		SANITARY SEWER LINE
		WATER LINE
		SANITARY SEWER LATERAL
		CLEAN OUT (INSTALL BY HOME BUILDER)
		WATER VALVE
		SINGLE WATER SERVICE
		DUAL WATER SERVICE
		FIRE HYDRANT
		PROPOSED SIDEWALK BY DEVELOPER
		WATER METER
		GAS VALVE
		GAS LINE
		STORM SEWER MANHOLE
		CURB INLET
		POWER POLE
		STREET LIGHT (100 WATT LED) STREET LIGHT (250 WATT LED)
		GUY WIRE
		OVERHEAD ELECTRIC
		BENCHMARK
		TOP OF MANHOLE
		EXISTING
		P.U.E. PUBLIC UTILITY EASEMENT
		ESMT EASEMENT
		VOL VOLUME
		PG PAGE

- NOTES:
- CONTRACTOR TO FIELD VERIFY EXACT LOCATION OF ALL EXISTING UTILITIES HORIZONTALLY AND VERTICALLY PRIOR TO CONSTRUCTION.
  - MANDREL TESTING WILL BE REQUIRED ON ALL FLEXIBLE GRAVITY WASTEWATER PIPE AS PRE TCEQ RULES.
  - ALL GRAVITY WASTEWATER LINES SHALL BE SDR-26 WWL ASTM D3034 UNLESS OTHERWISE NOTED.
  - CONTRACTOR TO FILL AND COMPACT TO 95% DENSITY IN FILL SECTIONS OVER WASTEWATER LINES. 2.0'(MIN.) COVER OVER WATER PRIOR TO CONSTRUCTION.
  - ALL SERVICES SHALL TERMINATE WITH A 2-WAY CLEANOUT.
  - ALL ON-SITE UTILITIES SHALL BE LOCATED UNDERGROUND UNLESS REQUIRED BY THE UTILITY TO BE OTHERWISE LOCATED (SECTION 25-2-1125).
  - WHERE THE MINIMUM 9 FOOT SEPARATION DISTANCE BETWEEN WASTEWATER LINES AND WATER LINES / MAINS CANNOT BE MAINTAINED, THE INSTALLATION OF WASTEWATER LINES SHALL BE IN STRICT ACCORDANCE WITH TCEQ. THE WASTEWATER LINE SHALL BE CONSTRUCTED OF CAST IRON, DUCTILE IRON OR PVC MEETING THE ASTM SPECIFICATION FOR BOTH PIPES AND JOINTS OF 150 PSI AND SHALL BE IN ACCORDANCE WITH 30 TAC § 217.53 (D) (3) (A) (I).

**CAUTION:** CONTRACTOR TO NOTIFY TEXAS ONE CALL AT 1-800-245-4545 48 HOURS PRIOR TO CONSTRUCTION FOR UTILITY LINE LOCATE. CONTRACTOR SHALL VERIFY HORIZONTAL AND VERTICAL LOCATION OF ALL EXISTING UTILITIES PRIOR TO CONSTRUCTION. ENGINEER SHALL BE NOTIFIED IMMEDIATELY OF ANY SIGNIFICANT DISCREPANCIES OR REQUIRED DESIGN CHANGES. EXISTING UTILITIES SHOWN HEREON ARE FOR INFORMATIONAL PURPOSES ONLY. ENGINEER ASSUMES NO RESPONSIBILITY FOR THE ACCURACY OF THIS INFORMATION.

**TRENCH EXCAVATION SAFETY PROTECTION**  
CONTRACTOR AND/OR CONTRACTOR'S INDEPENDENTLY RETAINED EMPLOYEE OR STRUCTURAL DESIGN/GEOTECHNICAL SAFETY EQUIPMENT CONSULTANT, IF ANY, SHALL REVIEW THESE PLANS AND AVAILABLE GEOTECHNICAL INFORMATION AND THE ANTICIPATED INSTALLATION SITE(S) WITHIN THE PROJECT WORK AREA IN ORDER TO IMPLEMENT CONTRACTOR'S TRENCH EXCAVATION SAFETY PROTECTION SYSTEMS, PROGRAMS AND/OR PROCEDURES. THE CONTRACTOR'S IMPLEMENTATION OF THE SYSTEMS, PROGRAMS AND/OR PROCEDURES SHALL PROVIDE FOR ADEQUATE TRENCH EXCAVATION, SAFETY PROTECTION THAT COMPLIES WITH AS A MINIMUM, OSHA STANDARDS FOR TRENCH EXCAVATIONS. SPECIFICALLY, CONTRACTOR AND/OR CONTRACTOR'S INDEPENDENTLY RETAINED EMPLOYEE OR SAFETY CONSULTANT SHALL IMPLEMENT A TRENCH SAFETY PROGRAM IN ACCORDANCE WITH OSHA STANDARDS GOVERNING THE PRESENCE AND ACTIVITIES OF INDIVIDUALS WORKING IN AND AROUND TRENCH EXCAVATION.

LOCATION OF EXISTING UNDERGROUND AND OVERHEAD UTILITIES ARE APPROXIMATE LOCATIONS ONLY. THE CONTRACTOR SHALL DETERMINE THE EXACT LOCATION OF ALL EXISTING UTILITIES PRIOR TO BEGINNING WORK AND SHALL BE FULLY RESPONSIBLE FOR ANY AND ALL DAMAGES WHICH MIGHT OCCUR.

Know what's below.  
Call before you dig.

VERAMENDI PRECINCT 19 UNIT 1  
WASTEWATER LAYOUT (SHEET 2 OF 3)

NO.	REVISIONS	DESCRIPTION	DATE	BY

DATE: 11/28/2023  
DESIGNED BY: NG  
DRAWN BY: TM  
CHECKED BY: PF  
DRAWING NAME: Wastewater Layout.dwg



**LJA Engineering, Inc.**  
9830 Calomarde Blvd  
Suite 300  
San Antonio, Texas 78230  
Phone 210.503.2700  
LJA.COM  
TBP# No. F-1386

JOB NUMBER: SA3856.0401  
SHEET NO. 39 OF 61 SHEETS

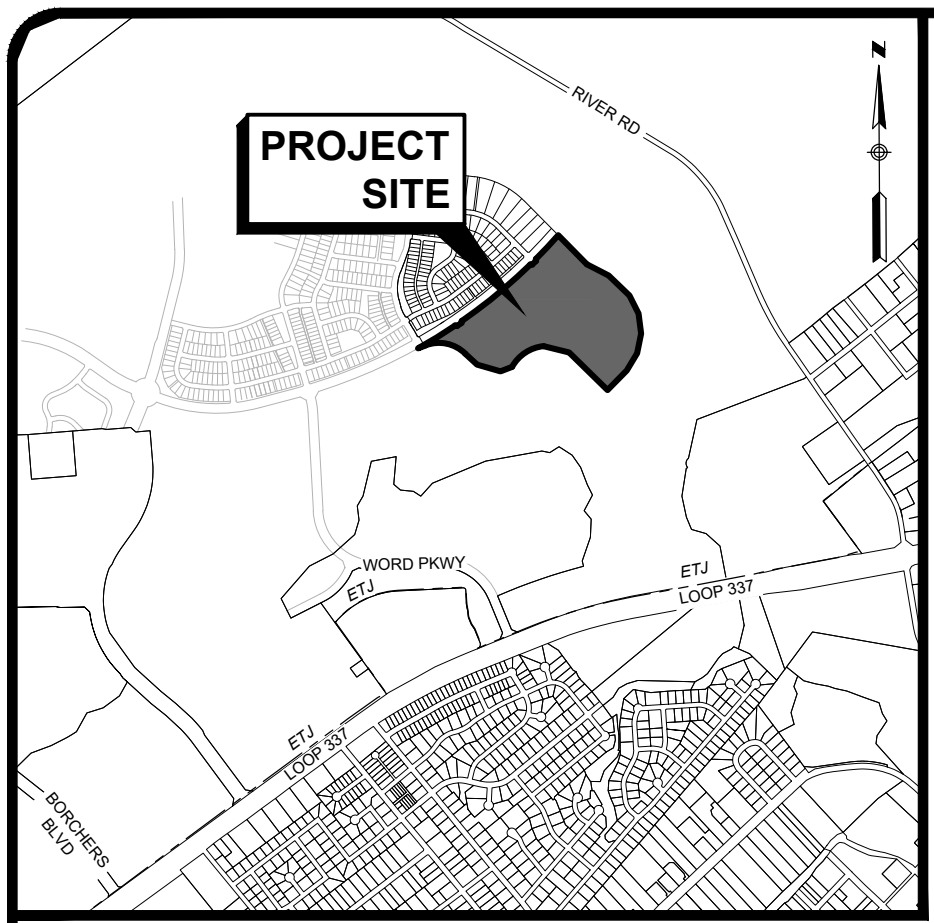

**LOCATION MAP**  
SCALE: 1" = 2000'

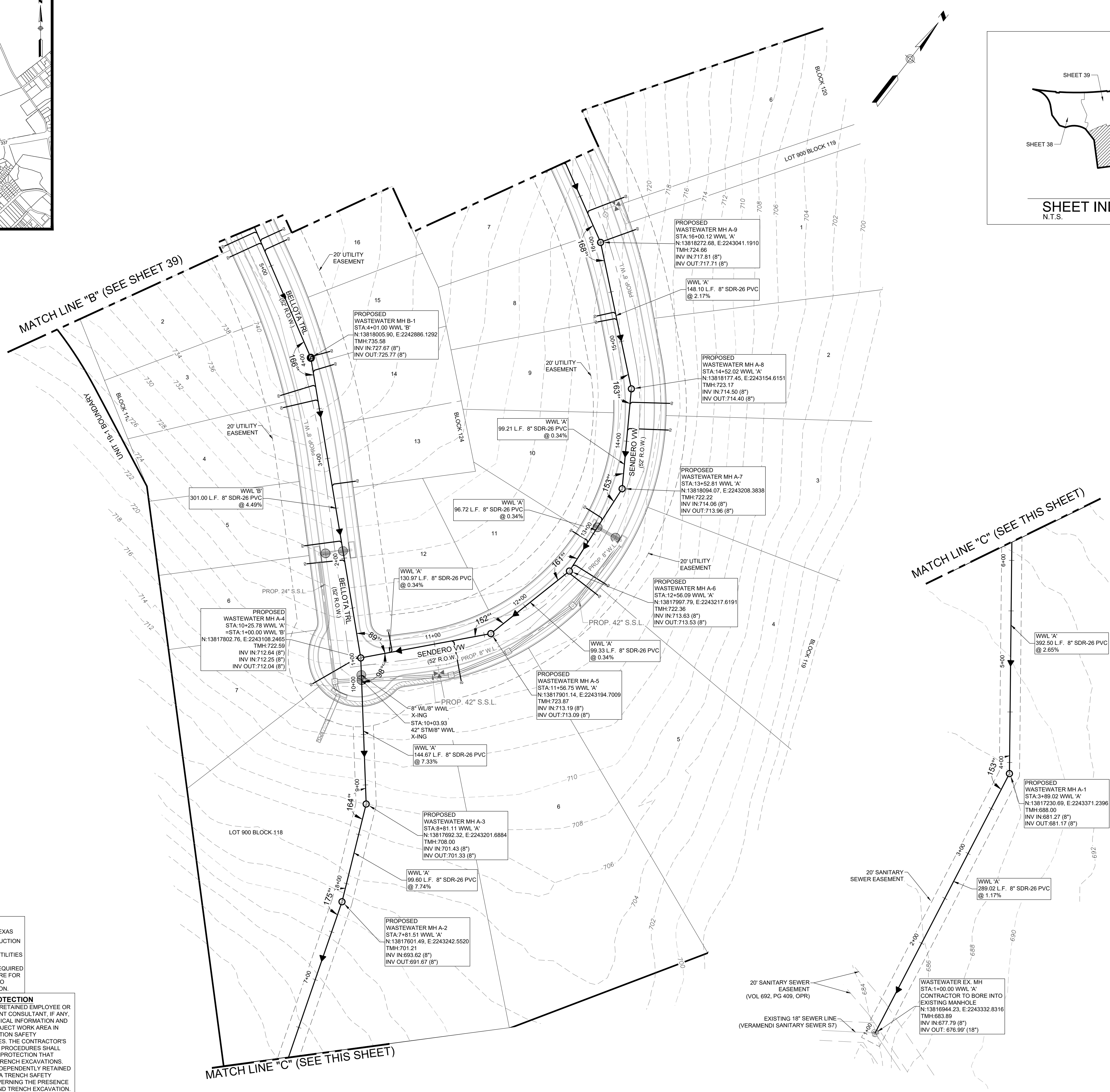
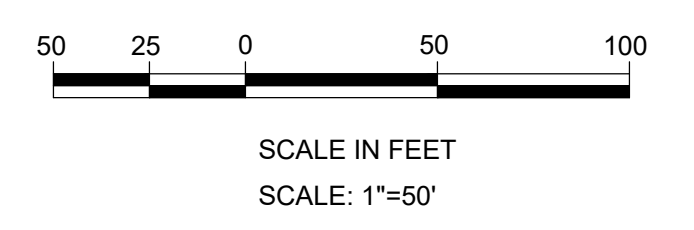
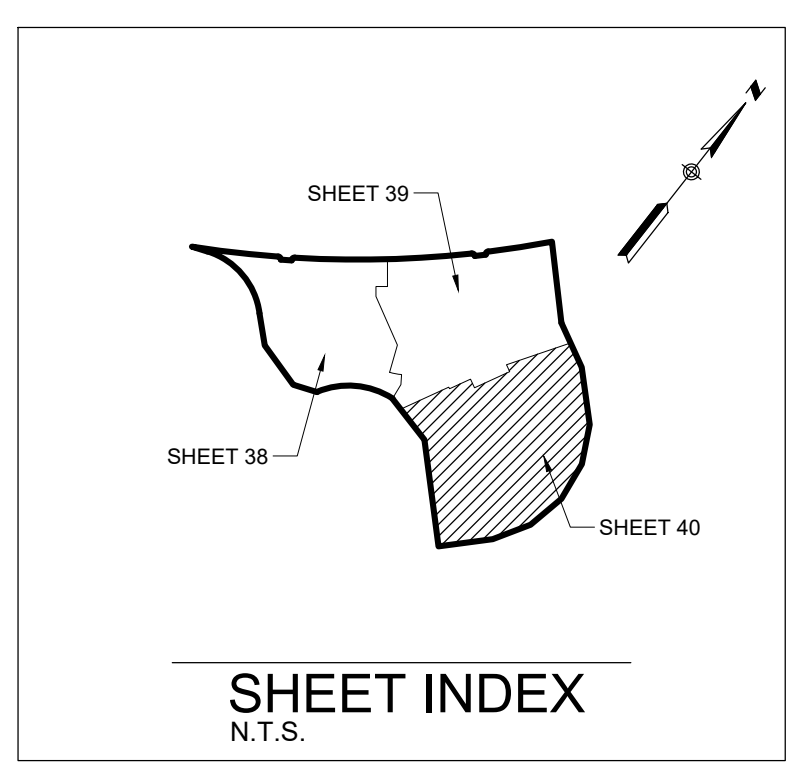

**LEGEND**

PROPOSED	EXISTING	DESCRIPTION
		SANITARY SEWER MANHOLE
		SANITARY SEWER LINE
		WATER LINE
		SANITARY SEWER LATERAL
		CLEAN OUT (INSTALL BY HOME BUILDER)
		WATER VALVE
		SINGLE WATER SERVICE
		DUAL WATER SERVICE
		FIRE HYDRANT
		PROPOSED SIDEWALK BY DEVELOPER
		WATER METER
		GAS VALVE
		GAS LINE
		STORM SEWER MANHOLE
		CURB INLET
		POWER POLE
		STREET LIGHT (100 WATT LED)
		STREET LIGHT (250 WATT LED)
		GUY WIRE
		OVERHEAD ELECTRIC
		BENCHMARK
		TOP OF MANHOLE
		EXISTING PUBLIC UTILITY EASEMENT
		EASEMENT
		EASEMENT
		VOLUME
		PAGE

- NOTES:**
- CONTRACTOR TO FIELD VERIFY EXACT LOCATION OF ALL EXISTING UTILITIES HORIZONTALLY AND VERTICALLY PRIOR TO CONSTRUCTION.
  - MANDREL TESTING WILL BE REQUIRED ON ALL FLEXIBLE GRAVITY WASTEWATER PIPE AS PRE TCEQ RULES.
  - ALL GRAVITY WASTEWATER LINES SHALL BE SDR-26 WWL ASTM D3034 UNLESS OTHERWISE NOTED.
  - CONTRACTOR TO FILL AND COMPACT TO 95% DENSITY IN FILL SECTIONS OVER WASTEWATER LINES. 2.0"(MIN.) COVER OVER WATER PRIOR TO CONSTRUCTION.
  - ALL SERVICES SHALL TERMINATE WITH A 2-WAY CLEANOUT.
  - ALL ON-SITE UTILITIES SHALL BE LOCATED UNDERGROUND UNLESS REQUIRED BY THE UTILITY TO BE OTHERWISE LOCATED (SECTION 25-2-1125).
  - WHERE THE MINIMUM 9 FOOT SEPARATION DISTANCE BETWEEN WASTEWATER LINES AND WATER LINES / MAINS CANNOT BE MAINTAINED, THE INSTALLATION OF WASTEWATER LINES SHALL BE IN STRICT ACCORDANCE WITH TCEQ. THE WASTEWATER LINE SHALL BE CONSTRUCTED OF CAST IRON, DUCTILE IRON OR PVC MEETING THE ASTM SPECIFICATION FOR BOTH PIPES AND JOINTS OF 150 PSI AND SHALL BE IN ACCORDANCE WITH 30 TAC § 217.53 (D) (3) (A) (I).

**CAUTION:** CONTRACTOR TO NOTIFY TEXAS ONE CALL AT 1-800-245-4545 48 HOURS PRIOR TO CONSTRUCTION FOR UTILITY LINE LOCATE. CONTRACTOR SHALL VERIFY HORIZONTAL AND VERTICAL LOCATION OF ALL EXISTING UTILITIES PRIOR TO CONSTRUCTION. ENGINEER SHALL BE NOTIFIED IMMEDIATELY OF ANY SIGNIFICANT DISCREPANCIES OR REQUIRED DESIGN CHANGES. EXISTING UTILITIES SHOWN HEREON ARE FOR INFORMATIONAL PURPOSES ONLY. ENGINEER ASSUMES NO RESPONSIBILITY FOR THE ACCURACY OF THIS INFORMATION.

**TRENCH EXCAVATION SAFETY PROTECTION**  
CONTRACTOR AND/OR CONTRACTOR'S INDEPENDENTLY RETAINED EMPLOYEE OR STRUCTURAL DESIGN/GEOTECHNICAL SAFETY/EQUIPMENT CONSULTANT, IF ANY, SHALL REVIEW THESE PLANS AND AVAILABLE GEOTECHNICAL INFORMATION AND THE ANTICIPATED INSTALLATION SITE(S) WITHIN THE PROJECT WORK AREA IN ORDER TO IMPLEMENT CONTRACTOR'S TRENCH EXCAVATION SAFETY PROTECTION SYSTEMS, PROGRAMS AND/OR PROCEDURES. THE CONTRACTOR'S IMPLEMENTATION OF THE SYSTEMS, PROGRAMS AND/OR PROCEDURES SHALL PROVIDE FOR ADEQUATE TRENCH EXCAVATION, SAFETY PROTECTION THAT COMPLIES WITH AS A MINIMUM, OSHA STANDARDS FOR TRENCH EXCAVATIONS. SPECIFICALLY, CONTRACTOR AND/OR CONTRACTOR'S INDEPENDENTLY RETAINED EMPLOYEE OR SAFETY CONSULTANT SHALL IMPLEMENT A TRENCH SAFETY PROGRAM IN ACCORDANCE WITH OSHA STANDARDS GOVERNING THE PRESENCE AND ACTIVITIES OF INDIVIDUALS WORKING IN AND AROUND TRENCH EXCAVATION.

LOCATION OF EXISTING UNDERGROUND AND OVERHEAD UTILITIES ARE APPROXIMATE LOCATIONS ONLY. THE CONTRACTOR SHALL DETERMINE THE EXACT LOCATION OF ALL EXISTING UTILITIES PRIOR TO BEGINNING WORK AND SHALL BE FULLY RESPONSIBLE FOR ANY AND ALL DAMAGES WHICH MIGHT OCCUR.

**VERAMENDI PRECINCT 19 UNIT 1**  
WASTEWATER LAYOUT (SHEET 3 OF 3)

NO.	DATE	REVISIONS	DESCRIPTION

DATE: 11/28/2023  
DESIGNED BY: NG  
DRAWN BY: TM  
CHECKED BY: PF  
DRAWING NAME: Wastewater Layout.dwg  
TBPE No. F-1386

**LJA Engineering, Inc.**  
9830 Calomarde Blvd  
Suite 300  
San Antonio, Texas 78230  
Phone 210.503.2700  
LJA.COM

JOB NUMBER: SA3856.0401  
SHEET NO. **40** OF 61 SHEETS

K:\QA\BIDD\ACA\Progress\5440\_Veramendi Precinct 19 Unit 1.dwg Site Development Plans\19-Unit 1.dwg - Wastewater Layout.dwg  
 User Modified: Nov 28, 2023 10:48  
 Plot Date: Nov 28, 2023 10:48













**LEGEND**

PROPOSED	EXISTING	
		SANITARY SEWER MANHOLE
		SANITARY SEWER LINE
		4" CONDUIT FOR WATER SERVICE
		WATER LINE
		SANITARY SEWER LATERAL
		CLEAN OUT
		WATER VALVE
		SINGLE WATER SERVICE
		DUAL WATER SERVICE
		FIRE HYDRANT
		WATER METER
		GAS VALVE
		GAS LINE
		STORM SEWER MANHOLE
		CURB INLET
		POWER POLE
		STREET LIGHT (100 WATT LED)
		STREET LIGHT (250 WATT LED)
		GUY WIRE
		OVERHEAD ELECTRIC
		BENCHMARK
		TOP OF MANHOLE
		EXISTING
		PUBLIC UTILITY EASEMENT
		EASEMENT
		VOLUME
		PAGE
		UTILITY X-ING

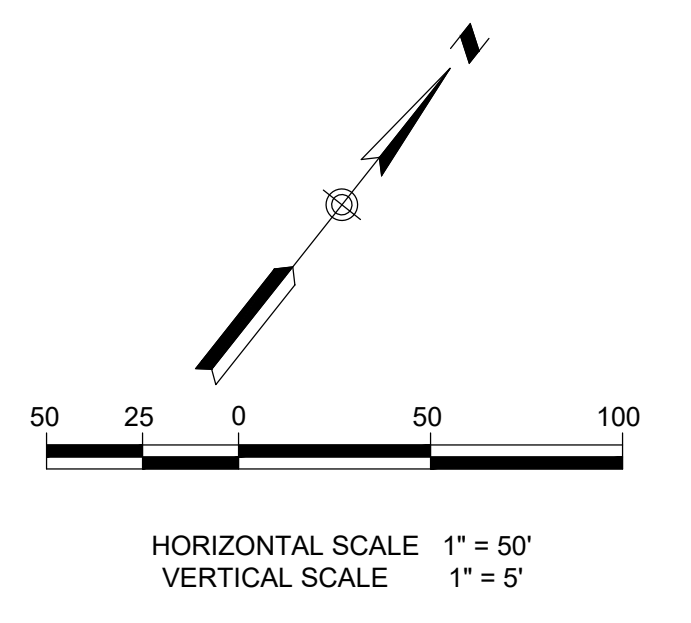
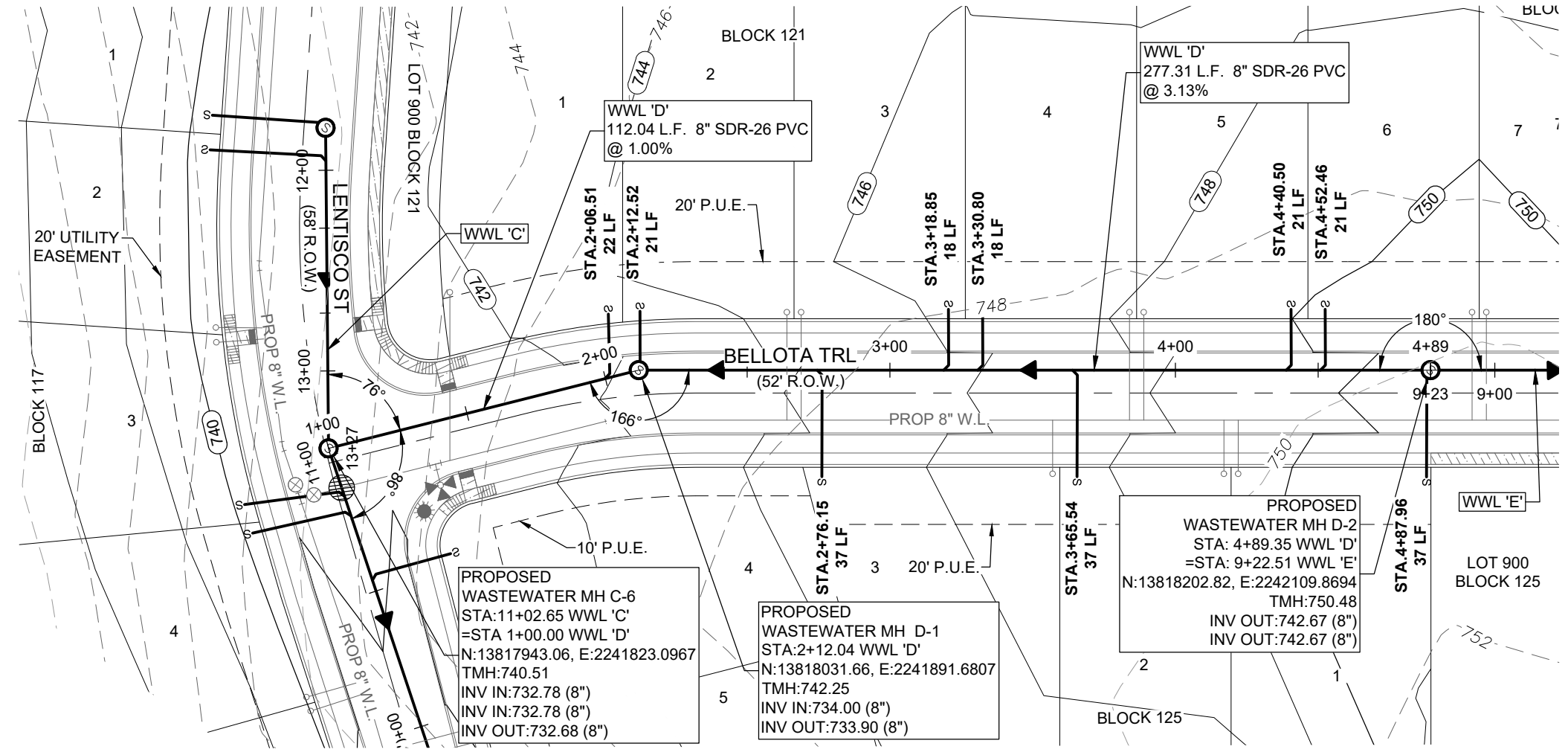

LOCATION OF EXISTING UNDERGROUND AND OVERHEAD UTILITIES ARE APPROXIMATE LOCATIONS ONLY. THE CONTRACTOR SHALL DETERMINE THE EXACT LOCATION OF ALL EXISTING UTILITIES PRIOR TO BEGINNING WORK AND SHALL BE FULLY RESPONSIBLE FOR ANY AND ALL DAMAGES WHICH MIGHT OCCUR.



**WASTEWATER LINE 'D' STA. 1+00 TO END**

**TRENCH EXCAVATION SAFETY PROTECTION**  
 CONTRACTOR AND/OR CONTRACTOR'S INDEPENDENTLY RETAINED EMPLOYEE OR STRUCTURAL DESIGN/GEOTECHNICAL/SAFETY EQUIPMENT CONSULTANT, IF ANY, SHALL REVIEW THESE PLANS AND AVAILABLE GEOTECHNICAL INFORMATION AND THE ANTICIPATED INSTALLATION SITE(S) WITHIN THE PROJECT WORK AREA IN ORDER TO IMPLEMENT CONTRACTOR'S TRENCH EXCAVATION SAFETY PROTECTION SYSTEMS, PROGRAMS AND/OR PROCEDURES. THE CONTRACTOR'S IMPLEMENTATION OF THE SYSTEMS, PROGRAMS AND/OR PROCEDURES SHALL PROVIDE FOR ADEQUATE TRENCH EXCAVATION, SAFETY PROTECTION THAT COMPLIES WITH AS A MINIMUM, OSHA STANDARDS FOR TRENCH EXCAVATIONS. SPECIFICALLY, CONTRACTOR AND/OR CONTRACTOR'S INDEPENDENTLY RETAINED EMPLOYEE OR SAFETY CONSULTANT SHALL IMPLEMENT A TRENCH SAFETY PROGRAM IN ACCORDANCE WITH OSHA STANDARDS GOVERNING THE PRESENCE AND ACTIVITIES OF INDIVIDUALS WORKING IN AND AROUND TRENCH EXCAVATION.

**CAUTION:** CONTRACTOR TO NOTIFY TEXAS ONE CALL AT 1-800-245-4545 48 HOURS PRIOR TO CONSTRUCTION FOR UTILITY LINE LOCATE. CONTRACTOR SHALL VERIFY HORIZONTAL AND VERTICAL LOCATION OF ALL EXISTING UTILITIES PRIOR TO CONSTRUCTION. ENGINEER SHALL BE NOTIFIED IMMEDIATELY OF ANY SIGNIFICANT DISCREPANCIES OR REQUIRED DESIGN CHANGES. EXISTING UTILITIES SHOWN HEREON ARE FOR INFORMATIONAL PURPOSES ONLY. ENGINEER ASSUMES NO RESPONSIBILITY FOR THE ACCURACY OF THIS INFORMATION.

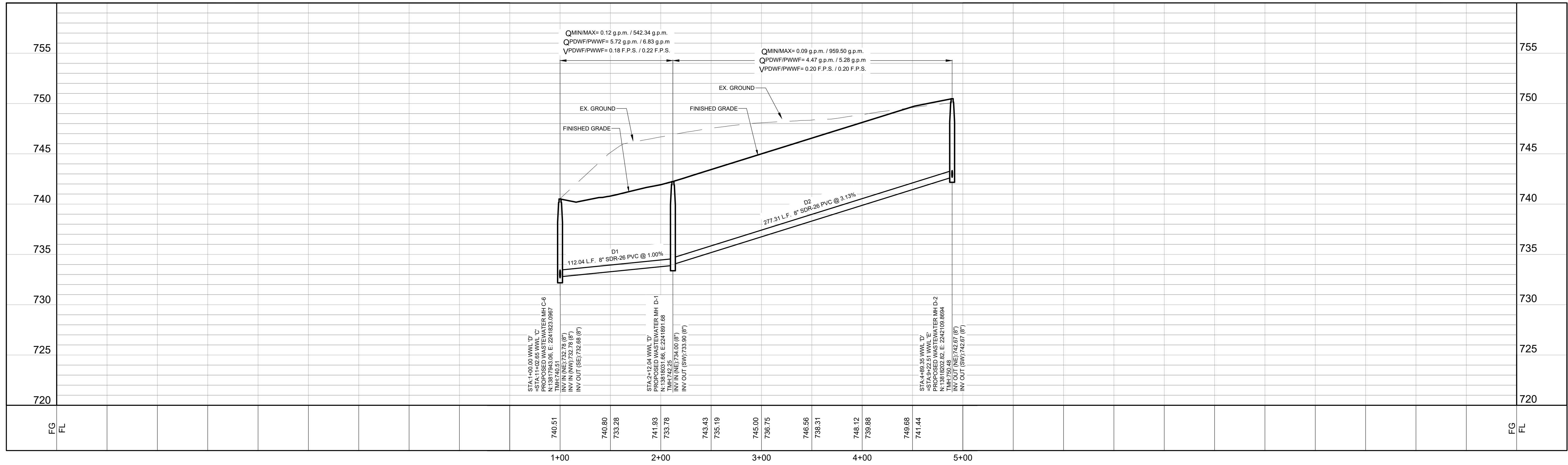

**VERAMENDI PRECINCT 19 UNIT 1**  
**WASTEWATER LINE 'D' PLAN & PROFILE**  
 STA. 1+00 TO END

NO.	DATE	BY	REVISIONS DESCRIPTION



**LJA Engineering, Inc.**  
 9830 Calomarde Blvd  
 Suite 300  
 San Antonio, Texas 78230  
 Phone 210.603.2700  
 LJA.COM  
 TBPE No. F-1386

JOB NUMBER: SA3856.0401  
 SHEET NO. **46**  
 OF 61 SHEETS

K:\QA\856\_ACA\Projects\856\Veramendi Precinct 19 Unit 1\Drawings\Plan\WWT\WWT\_19.dwg  
 User Modified: Nov 20, 2024 11:54  
 Plot Date/Time: Nov 20, 2024 11:54







**Texas Commission on Environmental Quality  
Organized Sewage Collection System  
General Construction Notes**

**Edwards Aquifer Protection Program Construction Notes – Legal Disclaimer**

The following/related "construction notes" are intended to be advisory in nature only and do not constitute an approval or conditional approval by the Executive Director, nor do they constitute a comprehensive listing of rules or conditions to be followed during construction. Further actions may be required to achieve compliance with TCEQ regulations found in Title 30, Texas Administrative Code, Chapters 213 and 217, as well as local ordinances and regulations providing for the protection of water quality. Additionally, nothing contained in the following/related "construction notes" restricts the powers of the Executive Director, the commission or any other governmental entity to prevent, correct, or control activities that result or may result in pollution of the Edwards Aquifer or hydrologically connected surface waters. The holder of any Edwards Aquifer Protection Plan containing "construction notes" is still responsible for compliance with Title 30, Texas Administrative Code, Chapters 213 or any other applicable TCEQ regulation, as well as all conditions of an Edwards Aquifer Protection Plan through all phases of plan implementation. Failure to comply with any condition of the Executive Director's approval, whether or not in contradiction of any "construction notes," is a violation of TCEQ regulations and any violation is subject to administrative rules, orders, and penalties as provided under Title 30, Texas Administrative Code § 213.10 (relating to Enforcement). Such violations may also be subject to civil penalties and injunction. The following/related "construction notes" in no way represent an approved regulation by the Executive Director to any part of Title 30 Texas Administrative Code, Chapters 213 and 217, or any other TCEQ approved regulation.

- This Organized Sewage Collection System (SCS) must be constructed in accordance with 30 Texas Administrative Code (TAC) §213.5(c), the Texas Commission on Environmental Quality's (TCEQ) Edwards Aquifer Rules and any local government standard specifications.
- All contractors conducting regulated activities associated with this proposed regulated project must be provided with copies of the SCS plan and the TCEQ letter indicating the specific conditions of its approval. During the course of these regulated activities, the contractors must be required to keep on-site copies of the plan and the approval letter.
- A written notice of construction must be submitted to the presiding TCEQ regional office at least 48 hours prior to the start of any regulated activities. This notice must include:
  - the name of the approved project;
  - the activity start date; and
  - the contact information of the prime contractor.
- Any modification to the activities described in the referenced SCS application following the date of approval may require the submission of an SCS application to modify this approval, including the payment of appropriate fees and all information necessary for its review and approval.
- Prior to beginning any construction activity, all temporary erosion and sedimentation (E&S) control measures must be properly installed and maintained in accordance with the manufacturers specifications. These controls must remain in place until the disturbed areas have been permanently stabilized.

- If any sensitive features are discovered during the wastewater line trenching activities, all regulated activities near the sensitive features must be suspended immediately. The applicant must immediately notify the appropriate regional office of the TCEQ of the feature discovered. A geologist's assessment of the location and extent of the feature discovered must be reported to that regional office in writing and the applicant must submit a plan for ensuring the structural integrity of the sewer line or for modifying the proposed collection system alignment around the feature. The regulated activities near the sensitive feature may not proceed until the date of approval may require the submission of an SCS application to modify this approval, including the payment of appropriate fees and all information necessary for its review and approval.

TCEQ-0596 (Rev. July 15, 2015) Page 1 of 6

executive director has reviewed and approved the methods proposed to protect the sensitive feature and the Edwards Aquifer from any potentially adverse impacts to water quality while maintaining the structural integrity of the line.

- Sewer lines located within or crossing the 5-year floodplain of a drainage way will be protected from inundation and stream velocities which could cause erosion and scouring of backfill. The trench must be capped with concrete to prevent scouring of backfill, or the sewer lines must be encased in concrete. All concrete shall have a minimum thickness of 6 inches.
- Blasting procedures for protection of existing sewer lines and other utilities will be in accordance with the National Fire Protection Association criteria. Sand is not allowed as bedding or backfill in trenches that have been blasted. If any existing sewer lines are damaged, the lines must be repaired and retested.
- All manholes constructed or rehabilitated on this project must have watertight size on size resilient connectors allowing for differential settlement. If manholes are constructed within the 100-year floodplain, the cover must have a gasket and be bolted to the ring. Where gasketed manhole covers are required for more than three manholes in sequence or for more than 1500 feet, alternate means of venting will be provided. Bricks are not an acceptable construction material for any portion of the manhole.

The diameter of the manholes must be a minimum of four feet and the manhole for entry must have a minimum clear opening diameter of 30 inches. These dimensions and other details showing compliance with the commission's rules concerning manholes and sewer line/manhole inverts described in 30 TAC §217.55 are included on Plan Sheet \_\_\_ of \_\_\_.

It is suggested that entrance into manholes in excess of four feet deep be accomplished by means of a portable ladder. The inclusion of steps in a manhole is prohibited.

- Where water lines and new sewer line are installed with a separation distance closer than nine feet (i.e., water lines crossing wastewater lines, water lines paralleling wastewater lines, or water lines next to manholes) the installation must meet the requirements of 30 TAC §217.53(d) (Pipe Design) and 30 TAC §290.44(e) (Water Distribution).
- Where sewers lines deviate from straight alignment and uniform grade all curvature of sewer pipe must be achieved by the following procedure which is recommended by the pipe manufacturer:
  - If pipe flexure is proposed, the following method of preventing deflection of the joint must be used: Specific care must be taken to ensure that the joint is placed in the center of the trench and properly bedded in accordance with 30 TAC §217.54.

- New sewage collection system lines must be constructed with stub outs for the connection of anticipated extensions. The location of such stub outs must be marked on the ground such that their location can be easily determined at the time of connection of the extensions. Such stub outs must be manufactured wyes or tees that are compatible in size and material with both the sewer line and the extension. At the time of original construction, new stub-outs must be constructed sufficiently to extend beyond the end of the street pavement. All stub-outs must be sealed with a manufactured cap to prevent leakage. Extensions that were not anticipated at the time of original construction or that are to be connected to an existing sewer line not furnished with stub outs must be connected using a manufactured saddle and in accordance with accepted plumbing techniques.

TCEQ-0596 (Rev. July 15, 2015) Page 2 of 6

If no stub-out is present an alternate method of joining laterals is shown in the detail on Plan Sheet \_\_\_ of \_\_\_ (For potential future laterals).

The private service lateral stub-outs must be installed as shown on the plan and profile sheets on Plan Sheet \_\_\_ of \_\_\_ and marked after backfilling as shown in the detail on Plan Sheet \_\_\_ of \_\_\_.

- Trenching, bedding and backfill must conform with 30 TAC §217.54. The bedding and backfill for flexible pipe must comply with the standards of ASTM D-2321, Classes IA, IB, II or III. Rigid pipe bedding must comply with the requirements of ASTM C 12 (ANSI A 106.2) classes A, B or C.
- Sewer lines must be tested from manhole to manhole. When a new sewer line is connected to an existing stub or clean-out, it must be tested from existing manhole to new manhole. If a stub or clean-out is used at the end of the proposed sewer line, no private service attachments may be connected between the last manhole and the cleanout unless it can be certified as conforming with the provisions of 30 TAC §213.5(c)(3)(E).

- All sewer lines must be tested in accordance with 30 TAC §217.57. The engineer must retain copies of all test results which must be made available to the executive director upon request. The engineer must certify in writing that all wastewater lines have passed all required testing to the appropriate regional office within 30 days of test completion and prior to use of the new collection system. Testing method will be:
  - For a collection system pipe that will transport wastewater by gravity flow, the design must specify an infiltration and exfiltration test or a low-pressure air test. A test must conform to the following requirements:
    - Low Pressure Air Test.
      - A low pressure air test must follow the procedures described in American Society For Testing And Materials (ASTM) C-628, ASTM C-924, or ASTM F-1417 or other procedure approved by the executive director, except as to testing times as required in Table C.3 in subparagraph (C) of this paragraph or Equation C.3 in subparagraph (B)(ii) of this paragraph.
      - For sections of collection system pipe less than 36 inch average inside diameter, the following procedure must apply, unless a pipe is to be tested as required by paragraph (2) of this subsection.
        - A pipe must be pressurized to 3.5 pounds per square inch (psi) greater than the pressure exerted by groundwater above the pipe.
        - Once the pressure is stabilized, the minimum time allowable for the pressure to drop from 3.5 psi gauge to 2.5 psi gauge is computed from the following equation:
 
$$T = \frac{0.085 \times D \times K}{Q}$$

Equation C.3  $T = \frac{0.085 \times D \times K}{Q}$

Where:  
T = time for pressure to drop 1.0 pound per square inch gauge in seconds  
K = 0.000419 X D X L, but not less than 1.0  
D = average inside pipe diameter in inches

L = length of line of same size being tested, in feet  
rate of loss, 0.0015 cubic feet per minute per square foot internal surface

(C) Since a K value of less than 1.0 may not be used, the minimum testing time for each pipe diameter is shown in the following Table C.3.

Pipe Diameter (inches)	Minimum Time (seconds)	Maximum Length for Minimum Time (feet)	Time for Longer Length (seconds/foot)
6	340	398	0.855
8	454	298	1.520
10	567	239	2.374
12	680	199	3.419
15	850	159	5.342
18	1020	133	7.693
21	1190	114	10.471
24	1360	100	13.676
27	1530	88	17.309
30	1700	80	21.369
33	1870	72	25.856

(D) An owner may stop a test if no pressure loss has occurred during the first 25% of the calculated testing time.

(E) If any pressure loss or leakage has occurred during the first 25% of a testing period, then the test must continue for the entire test duration as outlined above or until failure.

(F) Wastewater collection system pipes with a 27 inch or larger average inside diameter may be air tested at each joint instead of following the procedure outlined in this section.

(G) A testing procedure for pipe with an inside diameter greater than 33 inches must be approved by the executive director.

(2) Infiltration/Exfiltration Test.

(A) The total exfiltration, as determined by a hydrostatic head test, must not exceed 50 gallons per inch of diameter per mile of pipe per 24 hours at a minimum test head of 2.0 feet above the crown of a pipe at an upstream manhole.

(B) An owner shall use an infiltration test in lieu of an exfiltration test when pipes are installed below the groundwater level.

(C) The total exfiltration, as determined by a hydrostatic head test, must not exceed 50 gallons per inch of diameter per mile of pipe per 24 hours at a minimum test head of two feet above the crown of a pipe at an upstream manhole, or at least two feet above existing groundwater level, whichever is greater.

(D) For construction within a 25-year flood plain, the infiltration or exfiltration must not exceed 10 gallons per inch diameter per mile of pipe per 24 hours at the same minimum test head as in subparagraph (C) of this paragraph.

(E) If the quantity of infiltration or exfiltration exceeds the maximum quantity specified, an owner shall undertake remedial action in order to reduce

the infiltration or exfiltration to an amount within the limits specified. An owner shall retest a pipe following a remediation action.

(b) If a gravity collection pipe is composed of flexible pipe, deflection testing is also required. The following procedures must be followed:

(1) For a collection pipe with inside diameter less than 27 inches, deflection measurement requires a rigid mandrel.

(A) Mandrel Sizing.

(i) A rigid mandrel must have an outside diameter (OD) not less than 95% of the base inside diameter (ID) or average ID of a pipe, as specified in the appropriate standard by the ASTMs, American Water Works Association, UNI-BELL, or American National Standards Institute, or any related appendix.

(ii) If a mandrel sizing diameter is not specified in the appropriate standard, the mandrel must have an OD equal to 95% of the ID of a pipe. In this case, the ID of the pipe, for the purpose of determining the OD of the mandrel, must equal be the average outside diameter minus two minimum wall thicknesses for OD controlled pipe and the average inside diameter for ID controlled pipe.

(iii) All dimensions must meet the appropriate standard.

(B) Mandrel Design.

(i) A rigid mandrel must be constructed of a metal or a rigid plastic material that can withstand 200 psi without being deformed.

(ii) A mandrel must have nine or more odd number of runners or legs.

(iii) A barrel section length must equal at least 75% of the inside diameter of a pipe.

(iv) Each size mandrel must use a separate proving ring.

(C) Method Options.

(i) An adjustable or flexible mandrel is prohibited.

(ii) A test may not use television inspection as a substitute for a deflection test.

(iii) If requested, the executive director may approve the use of a deflectometer or a mandrel with removable legs or runners on a case-by-case basis.

(2) For a gravity collection system pipe with an inside diameter 27 inches and greater, other test methods may be used to determine vertical deflection.

(3) A deflection test method must be accurate to within plus or minus 0.2% deflection.

(4) An owner shall not conduct a deflection test until at least 30 days after the final backfill.

(5) Gravity collection system pipe deflection must not exceed five percent (5%).

(6) If a pipe section fails a deflection test, an owner shall correct the problem and conduct a second test after the final backfill has been in place at least 30 days.

- All manholes must be tested to meet or exceed the requirements of 30 TAC §217.58.

(a) All manholes must pass a leakage test.

(b) An owner shall test each manhole (after assembly and backfilling) for leakage, separate and independent of the collection system pipes, by hydrostatic exfiltration testing, vacuum testing, or other method approved by the executive director.

(1) Hydrostatic Testing.

(A) The maximum leakage for hydrostatic testing or any alternative test methods is 0.025 gallons per foot diameter per foot of manhole depth per hour.

(B) To perform a hydrostatic exfiltration test, an owner shall seal all wastewater pipes coming into a manhole with an internal pipe plug, fill the manhole with water, and maintain the test for at least one hour.

(C) A test for concrete manholes may use a 24-hour wetting period before testing to allow saturation of the concrete.

(2) Vacuum Testing.

(A) To perform a vacuum test, an owner shall plug all lift holes and exterior joints with a non-shrink grout and plug all pipes entering a manhole.

(B) No grout must be placed in horizontal joints before testing.

(C) Stub-outs, manhole boots, and pipe plugs must be secured to prevent movement while a vacuum is drawn.

(D) An owner shall use a minimum 60 inch/lb torque wrench to tighten the external clamps that secure a test cover to the top of a manhole.

(E) A test head must be placed at the inside of the top of a cone section, and the seal inflated in accordance with the manufacturer's recommendations.

(F) There must be a vacuum of 10 inches of mercury inside a manhole to perform a valid test.

(G) A test does not begin until after the vacuum pump is off.

(H) A manhole passes the test if after 2.0 minutes and with all valves closed, the vacuum is at least 9.0 inches of mercury.

- All private service laterals must be inspected and certified in accordance with 30 TAC §213.5(c)(3)(i). After installation of and, prior to covering and connecting a private service lateral to an existing organized sewage collection system, a Texas Licensed Professional Engineer, Texas Registered Sanitarian, or appropriate city inspector must visually inspect the private service lateral and the connection to the sewage collection system, and certify that it is constructed in conformity with the applicable provisions of this section. The owner of the collection system must maintain such certifications for five years and forward copies to the appropriate regional office upon request. Connections may only be made to an approved sewage collection system.

Austin Regional Office 12100 Park 35 Circle, Building A Austin, Texas 78753-1808 Phone (512) 335-2929 Fax (512) 339-3795	San Antonio Regional Office 14250 Judson Road San Antonio, Texas 78233-4480 Phone (210) 490-3058 Fax (210) 545-4329
--	---

THESE GENERAL CONSTRUCTION NOTES MUST BE INCLUDED ON THE CONSTRUCTION PLANS PROVIDED TO THE CONTRACTOR AND ALL SUBCONTRACTORS.

CITY OF NEW BRAUNFELS NOTES:

- NO VALVES, HYDRANTS, ETC. SHALL BE CONSTRUCTED WITHIN CURBS, SIDEWALKS, OR DRIVEWAYS.
- ALL UTILITIES TO BE CONSTRUCTED PRIOR TO STREETS.
- THIS PROJECT INCLUDES UTILITY INSTALLATIONS GREATER THAN 5-FEET IN DEPTH. DEEP TRENCHES POSE COMPACTION TESTING AND CONSTRUCTION CHALLENGES AND CITY METHODS FOR TESTING AND COMPACTION MAY NOT BE ACHIEVABLE. A UTILITY COMPACTION PLAN WILL BE REQUIRED AND MUST BE SUBMITTED FOR APPROVAL TO CITY PRIOR TO UTILITY INSTALLATION.
- UTILITY TRENCH COMPACTION - ALL UTILITY TRENCH COMPACTION TESTS WITHIN THE STREET PAVEMENT/SIDEWALK SECTION SHALL BE THE RESPONSIBILITY OF THE DEVELOPER'S GEOTECHNICAL ENGINEER. FILL MATERIAL SHALL BE PLACED IN UNIFORM LAYERS NOT TO EXCEED TWELVE INCHES (12") LOOSE. DETERMINE THE MAXIMUM LIFT THICKNESS BASED ON THE ABILITY OF THE COMPACTING OPERATION AND EQUIPMENT USED TO MEET THE REQUIRED DENSITY. EACH LAYER OF MATERIAL SHALL BE COMPACTED TO A MINIMUM 85% DENSITY AND TESTED FOR DENSITY AND MOISTURE IN ACCORDANCE WITH TEST METHODS TEX-113-E, TEX-114-E, TEX-115-E. THE NUMBER AND LOCATION OF REQUIRED TESTS SHALL BE DETERMINED BY THE GEOTECHNICAL ENGINEER AND APPROVED BY THE CITY OF NEW BRAUNFELS STREET INSPECTOR AT A MINIMUM. TESTS SHALL BE TAKEN EVERY 200 LF FOR EACH LIFT AND EVERY OTHER SERVICE LINE. UPON COMPLETION OF TESTING THE GEOTECHNICAL ENGINEER SHALL PROVIDE THE CITY OF NEW BRAUNFELS STREET INSPECTOR WITH ALL TESTING DOCUMENTATION AND A CERTIFICATION STATING THAT THE PLACEMENT OF FILL MATERIAL HAS BEEN COMPLETED IN ACCORDANCE WITH THE PLANS. ADDITIONAL DENSITY TESTS MAY BE REQUESTED BY THE CITY OF NEW BRAUNFELS INSPECTOR.

23. UTILITY TRENCH COMPACTION WITH STREET R.O.W.

1. ALL UTILITY TRENCH COMPACTION TEST WITHIN THE STREET PAVEMENT SECTION SHALL BE THE RESPONSIBILITY OF THE DEVELOPER'S GEO-TECHNICAL ENGINEER.

2. FILL MATERIAL SHALL BE PLACED IN UNIFORM LAYERS NOT TO EXCEED TWELVE INCHES (12") LOOSE.

3. EACH LAYER OF MATERIAL SHALL BE COMPACTED AS SPECIFIED AND TESTED FOR DENSITY AND MOISTURE IN ACCORDANCE WITH TEST METHODS TEX-113-E, TEX-114-E, TEX-115-E.

4. THE NUMBER AND LOCATION OF REQUIRED TESTS SHALL BE DETERMINED BY THE GEO-TECHNICAL ENGINEER AND APPROVED BY THE CITY OF NEW BRAUNFELS STREET INSPECTOR.

5. UPON COMPLETION OF TESTING THE GEO-TECHNICAL ENGINEER SHALL PROVIDE THE CITY OF NEW BRAUNFELS STREET INSPECTOR WITH ALL TESTING DOCUMENTATION AND A CERTIFICATION STATING THAT THE PLACEMENT OF FILL MATERIAL HAS BEEN COMPLETED IN ACCORDANCE WITH THE PLANS.

24. UTILITY TRENCH COMPACTION WITH STREET R.O.W.

1. ALL UTILITY TRENCH COMPACTION TEST WITHIN THE STREET PAVEMENT SECTION SHALL BE THE RESPONSIBILITY OF THE DEVELOPER'S GEO-TECHNICAL ENGINEER.

2. FILL MATERIAL SHALL BE PLACED IN UNIFORM LAYERS NOT TO EXCEED TWELVE INCHES (12") LOOSE.

3. EACH LAYER OF MATERIAL SHALL BE COMPACTED AS SPECIFIED AND TESTED FOR DENSITY AND MOISTURE IN ACCORDANCE WITH TEST METHODS TEX-113-E, TEX-114-E, TEX-115-E.

4. THE NUMBER AND LOCATION OF REQUIRED TESTS SHALL BE DETERMINED BY THE GEO-TECHNICAL ENGINEER AND APPROVED BY THE CITY OF NEW BRAUNFELS STREET INSPECTOR.

5. UPON COMPLETION OF TESTING THE GEO-TECHNICAL ENGINEER SHALL PROVIDE THE CITY OF NEW BRAUNFELS STREET INSPECTOR WITH ALL TESTING DOCUMENTATION AND A CERTIFICATION STATING THAT THE PLACEMENT OF FILL MATERIAL HAS BEEN COMPLETED IN ACCORDANCE WITH THE PLANS.

**NBU WATER CONNECTION POLICY GENERAL NOTES:**

- ALL MATERIALS AND CONSTRUCTION PROCEDURES WITHIN THE SCOPE OF THE PROJECT SHALL BE APPROVED BY NEW BRAUNFELS UTILITIES AND COMPLY WITH THE CURRENT NEW BRAUNFELS UTILITIES WATER SYSTEMS CONNECTION/CONSTRUCTION POLICIES WATER SYSTEMS".
- CONTRACTOR SHALL NOT PROCEED WITH ANY PIPE INSTALLATION WORK UNTIL THEY OBTAIN A COPY OF THE PLANS FROM THE CONSULTANT OR ENGINEER AND NOTIFY NBU WATER SYSTEMS ENGINEERING AT 830-608-8971 WITH AT LEAST THREE (3) WORKING DAYS (72 HOURS) NOTICE. WORK COMPLETED BY THE CONTRACTOR, WHICH HAS NOT RECEIVED A NOTICE TO PROCEED WITH NEW BRAUNFELS UTILITIES WATER SYSTEMS ENGINEERING WILL BE SUBJECT TO REMOVAL AND REPLACEMENT BY AND AT THE EXPENSE OF THE CONTRACTOR.
- THE DEVELOPER DEDICATES THE WATER / WASTEWATER MAINS UPON COMPLETION BY THE DEVELOPER AND ACCEPTANCE BY THE NEW BRAUNFELS UTILITIES WATER SYSTEM. NBU WILL OWN AND MAINTAIN SAID WATER / WASTEWATER MAINS WHICH ARE LOCATED WITHIN SAID PARTICULAR SUBDIVISION. (AS APPLICABLE).
- CONTRACTOR AGREES TO ASSUME SOLE AND COMPLETE RESPONSIBILITY FOR JOB SITE CONDITIONS DURING THE CONSTRUCTION OF THE PROJECT, INCLUDING SAFETY OF ALL PERSONS AND PROPERTY. THIS REQUIREMENT SHALL APPLY CONTINUOUSLY AND NOT BE LIMITED TO NORMAL WORKING HOURS. THE CONTRACTOR SHALL DEFEND, INDEMNIFY AND HOLD THE OWNERS AND THE ENGINEER AND HIS EMPLOYEES, PARTNERS OFFICERS, DIRECTORS, OR CONSULTANTS HARMLESS FROM ANY AND ALL LIABILITY, REAL OR ALLEGED, IN CONNECTION WITH THE PERFORMANCE OF THE WORK ON THIS PROJECT, EXCEPTING FROM LIABILITY ARISING FROM SOLE NEGLIGENCE OF THE OWNER OR ENGINEER, ENGINEER'S DIRECTIONS, OFFICERS, EMPLOYEES, OR CONSULTANTS.
- CONTRACTOR AND / OR CONTRACTOR'S INDEPENDENTLY RETAINED EMPLOYEE OR SAFETY CONSULTANT SHALL IMPLEMENT A TRENCH SAFETY PROGRAM IN ACCORDANCE WITH OSHA STANDARDS GOVERNING THE PRESENCE AND ACTIVITIES OF INDIVIDUALS WORKING IN AND AROUND TRENCH EXCAVATION.
- CONTRACTOR SHALL BE RESPONSIBLE FOR RESTORING TO ITS ORIGINAL OR BETTER CONDITION, ANY DAMAGES DONE TO EXISTING FENCES, CURBS, STREETS, DRIVEWAYS, LANDSCAPING AND STRUCTURES, AND EXISTING UTILITIES (NOT ADJUSTED ON PLANS). COST OF RESTORATIONS, IF ANY, SHALL BE THE CONTRACTOR'S ENTIRE EXPENSE.
- THE CONTRACTOR SHALL AVOID CUTTING ROOTS LARGER THAN ONE INCH IN DIAMETER WHEN EXCAVATING NEAR EXISTING TREES. EXCAVATION IN VICINITY OF TREES SHALL PROCEED WITH CAUTION.
- CONTRACTOR SHALL PROCURE ALL PERMITS AND LICENSES, PAY ALL CHARGES, FEES AND TAXES AND GIVE ALL NOTICES NECESSARY AND INCIDENTAL TO THE DUE AND LAWFUL PROSECUTION OF THE WORK.
- NO EXTRA PAYMENT SHALL BE ALLOWED FOR WORK CALLED FOR ON THE PLANS BUT NOT INCLUDED ON THE BID SCHEDULE. THIS INCIDENTAL WORK WILL BE REQUIRED AND SHALL BE INCLUDED UNDER THE PAY ITEM TO WHICH IT RELATES.
- CONTRACTOR IS RESPONSIBLE FOR REMOVAL OF ALL WASTE MATERIALS UPON PROJECT COMPLETION. THE CONTRACTOR SHALL NOT PERMANENTLY PLACE ANY WASTE MATERIALS IN THE 100-YEAR FLOOD PLAN WITHOUT FIRST OBTAINING AN APPROVED FLOOD PLAIN DEVELOPMENT PERMIT.
- THE CONTRACTOR SHALL NOT PLACE ANY MATERIALS ON THE RECHARGE ZONE OF THE EDWARDS AQUIFER WITHOUT AN APPROVED WATER POLLUTION ABATEMENT PLAN FROM THE TCEQ 31 TAC 313.4 AND 31 TAC 313.9.
- BARRICADES AND WARNING SIGNS SHALL CONFORM TO THE "TEXAS MANUAL ON UNIFORM TRAFFIC CONTROL DEVICES" AND SHALL BE LOCATED TO PROVIDE MAXIMUM PROTECTION TO THE PUBLIC AS WELL AS CONSTRUCTION PERSONNEL AND EQUIPMENT WHILE PROVIDING CONTINUOUS TRAFFIC FLOW AT ALL TIMES DURING CONSTRUCTION. THE CONTRACTOR IS RESPONSIBLE FOR MAINTAINING ALL DEVICES DURING CONSTRUCTION.
- CONTRACTOR IS REQUIRED TO VERIFY PROJECT ELEVATIONS. THE TERM "MATCH EXISTING" SHALL BE UNDERSTOOD TO SIGNIFY BOTH HORIZONTAL AND VERTICAL ALIGNMENT.
- THE LOCATION OF UTILITIES, EITHER UNDERGROUND OR OVERHEAD, SHOWN WITHIN THE RIGHT OF WAY ARE APPROXIMATE AND SHALL BE VERIFIED BY THE CONTRACTOR BEFORE BEGINNING CONSTRUCTION OPERATIONS.
- OSHA REGULATIONS PROHIBIT OPERATIONS THAT WILL BRING PERSONS OR EQUIPMENT WITHIN 10 FEET OF AN ENERGIZED LINE, WHERE WORKMEN AND/OR EQUIPMENT HAVE TO TRAFFIC IN ONE DIRECTION AT ALL TIMES. THE CONTRACTOR SHALL NOTIFY THE ELECTRICAL POWER COMPANY INVOLVED AND MAKE WHATEVER ADJUSTMENTS NECESSARY TO ENSURE THE SAFETY OF THOSE WORKMEN.
- IT SHALL BE THE CONTRACTOR'S RESPONSIBILITY TO LOCATE UTILITY SERVICE LINES AS REQUIRED FOR CONSTRUCTION. UTILITY COMPANIES ARE ALSO PREVIOUSLY MENTIONED IN "UTILITY COMPANY NOTIFICATION".
- DUE TO FEDERAL REGULATIONS TITLE 49, PART 192 (8), GAS COMPANIES MUST MAINTAIN ACCESS TO GAS VALVES AT ALL TIMES. THE CONTRACTOR MUST PROTECT AND WORK AROUND ANY GAS VALVES THAT ARE IN THE PROJECT AREA.
- THE CONTRACTOR IS FULLY RESPONSIBLE FOR THE TRAFFIC CONTROL AND WILL BE RESPONSIBLE FOR FURNISHING ALL TRAFFIC CONTROL DEVICES, AND FLAGGERS. THE CONSTRUCTION METHODS SHALL BE CONDUCTED TO PROVIDE THE LEAST POSSIBLE INTERFERENCE TO TRAFFIC SO AS TO PERMIT THE CONTINUOUS MOVEMENT OF THE TRAFFIC IN ONE DIRECTION AT ALL TIMES. THE CONTRACTOR SHALL CLEAN UP AND REMOVE FROM THE WORK AREA ANY LOOSE MATERIAL, RESULTING FROM CONTRACT OPERATIONS AT THE END OF EACH WORKDAY.
- PRIOR TO ORDERING MATERIALS TO BE USED IN CONSTRUCTION, CONTRACTOR SHALL PROVIDE THE ENGINEER WITH FOUR (4) COPIES OF THE SOURCE, TYPE, GRADATION, MATERIAL SPECIFICATION DATA AND / OR SHOP DRAWINGS, AS APPLICABLE, TO SATISFY THE REQUIREMENTS OF THE FOLLOWING ITEMS AND ALL MATERIAL ITEMS REFERRED TO IN THESE LISTED ITEMS:
  - WATER MAINS AND SERVICES
  - SEWER MAINS AND SERVICES
- NO METER BOXES TO BE SET IN DRIVEWAYS. ANY METER BOXES SET IN DRIVEWAYS WILL BE RELOCATED AT CONTRACTOR'S AND/OR DEVELOPER'S EXPENSE.
- WHERE THE MINIMUM 9 FOOT SEPARATION DISTANCE BETWEEN SEWER LINES AND WATER LINES / MAINS CANNOT BE MAINTAINED, THE INSTALLATION OF SEWER LINES SHALL BE IN STRICT ACCORDANCE WITH TCEQ.
- CONTRACTOR AND/OR CONTRACTOR'S INDEPENDENTLY RETAINED EMPLOYEE OR STRUCTURAL DESIGN/GEOTECHNICAL SAFETY/EQUIPMENT CONSULTANT, IF ANY, SHALL REVIEW THESE PLANS AND AVAILABLE GEOTECHNICAL INFORMATION AND THE ANTICIPATED INSTALLATION SITE(S) WITHIN THE PROJECT WORK AREA IN ORDER TO IMPLEMENT CONTRACTOR'S TRENCH EXCAVATION SAFETY PROTECTION SYSTEMS, PROGRAMS AND/OR PROCEDURES. THE CONTRACTOR'S IMPLEMENTATION OF THE SYSTEMS, PROGRAMS AND/OR PROCEDURES SHALL PROVIDE FOR ADEQUATE TRENCH EXCAVATION SAFETY PROTECTION THAT COMPLIES WITH AS A MINIMUM, OSHA STANDARDS FOR TRENCH EXCAVATIONS. SPECIFICALLY, CONTRACTOR AND/OR CONTRACTOR'S INDEPENDENTLY RETAINED EMPLOYEE OR SAFETY CONSULTANT SHALL IMPLEMENT A TRENCH SAFETY PROGRAM IN ACCORDANCE WITH OSHA STANDARDS GOVERNING THE PRESENCE AND ACTIVITIES OF INDIVIDUALS WORKING IN AND AROUND TRENCH EXCAVATION.

VERAMENDI PRECINCT 19 UNIT 1  
WASTEWATER DETAILS (SHEET 2 OF 2)

NO.	DESCRIPTION	DATE	BY

DATE	DESIGNED BY	DRAWN BY	CHECKED BY
11/30/2023	NG	PF	PF

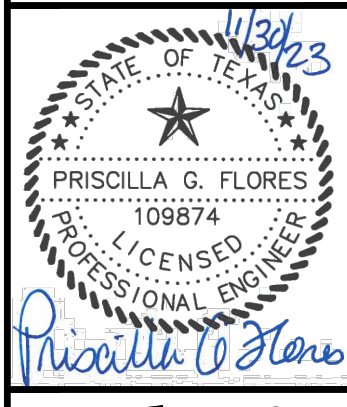

**LJA Engineering, Inc.**  
9830 Calomarde Blvd  
Suite 300  
San Antonio, Texas 78230  
Phone 210.503.2700  
LJA.COM  
TBP# No. F-1386

- WHERE THE MINIMUM 9 FOOT SEPARATION DISTANCE BETWEEN SEWER LINES AND WATER LINES / MAINS CANNOT BE MAINTAINED, THE INSTALLATION OF SEWER LINES SHALL BE IN STRICT ACCORDANCE WITH TCEQ.
- CONTRACTOR AND/OR CONTRACTOR'S INDEPENDENTLY RETAINED EMPLOYEE OR STRUCTURAL DESIGN/GEOTECHNICAL SAFETY/EQUIPMENT CONSULTANT, IF ANY, SHALL REVIEW THESE PLANS AND AVAILABLE GEOTECHNICAL INFORMATION AND THE ANTICIPATED INSTALLATION SITE(S) WITHIN THE PROJECT WORK AREA IN ORDER TO IMPLEMENT CONTRACTOR'S TRENCH EXCAVATION SAFETY PROTECTION SYSTEMS, PROGRAMS AND/OR PROCEDURES. THE CONTRACTOR'S IMPLEMENTATION OF THE SYSTEMS, PROGRAMS AND/OR PROCEDURES SHALL PROVIDE FOR ADEQUATE TRENCH EXCAVATION SAFETY PROTECTION THAT COMPLIES WITH AS A MINIMUM, OSHA STANDARDS FOR TRENCH EXCAVATIONS. SPECIFICALLY, CONTRACTOR AND/OR CONTRACTOR'S INDEPENDENTLY RETAINED EMPLOYEE OR SAFETY CONSULTANT SHALL IMPLEMENT A TRENCH SAFETY PROGRAM IN ACCORDANCE WITH OSHA STANDARDS GOVERNING THE PRESENCE AND ACTIVITIES OF INDIVIDUALS WORKING IN AND AROUND TRENCH EXCAVATION.
- UTILITY TRENCH COMPACTION WITH STREET R.O.W.
- ALL UTILITY TRENCH COMPACTION TEST WITHIN THE STREET PAVEMENT SECTION SHALL BE THE RESPONSIBILITY OF THE DEVELOPER'S GEO-TECHNICAL ENGINEER.
- FILL MATERIAL SHALL BE PLACED IN UNIFORM LAYERS NOT TO EXCEED TWELVE INCHES (12") LOOSE.
- EACH LAYER OF MATERIAL SHALL BE COMPACTED AS SPECIFIED AND TESTED FOR DENSITY AND MOISTURE IN ACCORDANCE WITH TEST METHODS TEX-113-E, TEX-114-E, TEX-115-E.
- THE NUMBER AND LOCATION OF REQUIRED TESTS SHALL BE DETERMINED BY THE GEO-TECHNICAL ENGINEER AND APPROVED BY THE CITY OF NEW BRAUNFELS STREET INSPECTOR.
- UPON COMPLETION OF TESTING THE GEO-TECHNICAL ENGINEER SHALL PROVIDE THE CITY OF NEW BRAUNFELS STREET INSPECTOR WITH ALL TESTING DOCUMENTATION AND A CERTIFICATION STATING THAT THE PLACEMENT OF FILL MATERIAL HAS BEEN COMPLETED IN ACCORDANCE WITH THE PLANS.

JOB NUMBER:  
SA3856.0401

SHEET NO.

50

OF 61 SHEETS



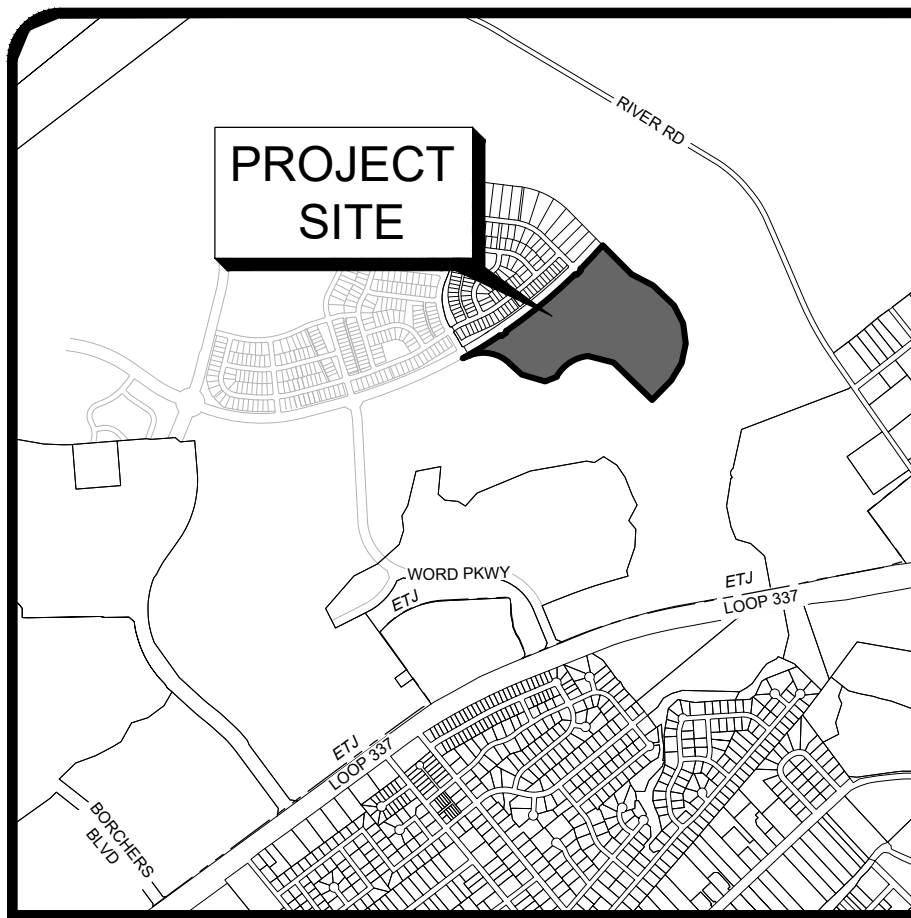

LOCATION MAP  
SCALE: 1" = 2000'

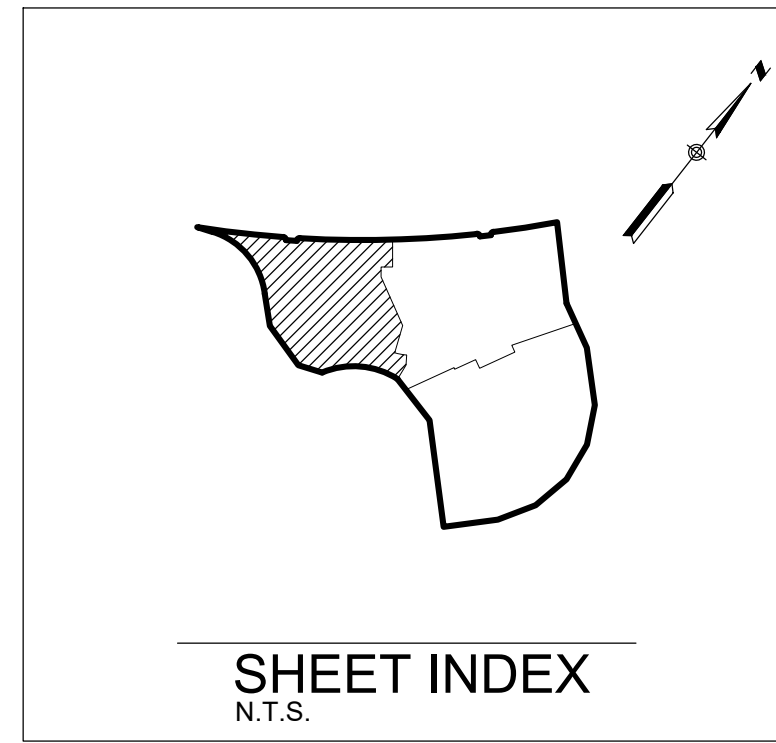

SHEET INDEX  
N.T.S.

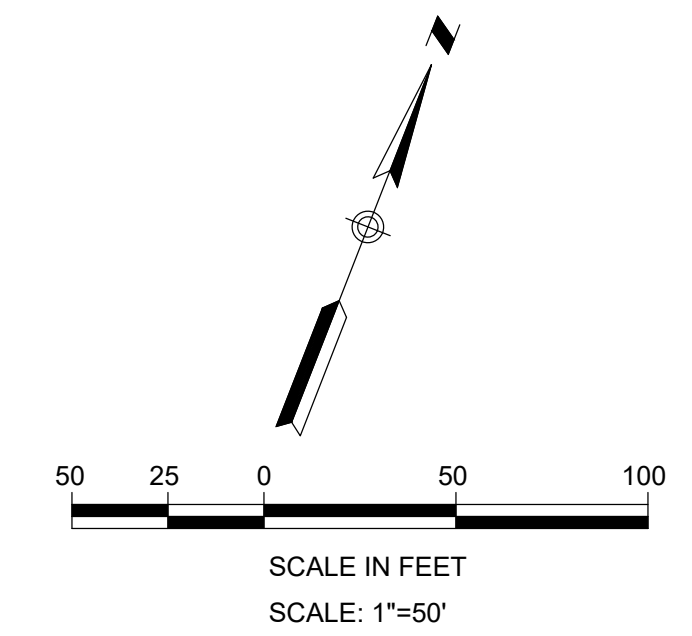
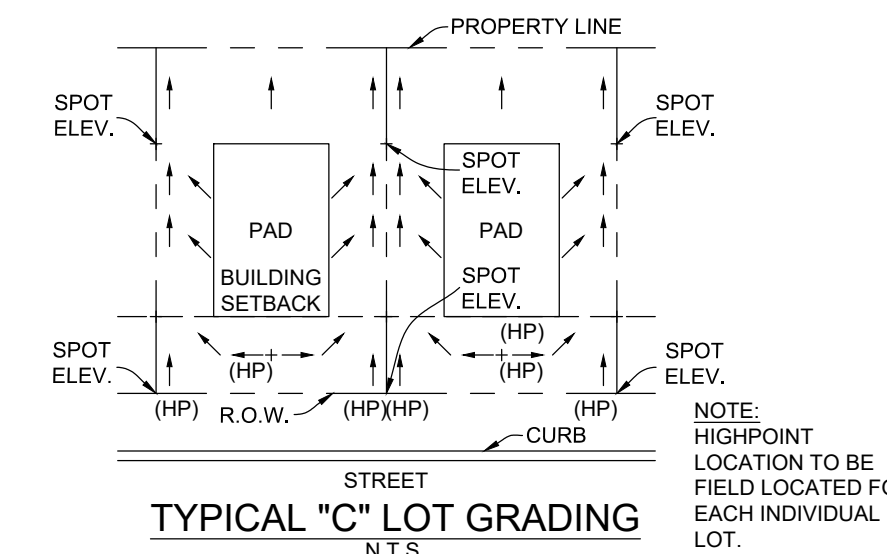
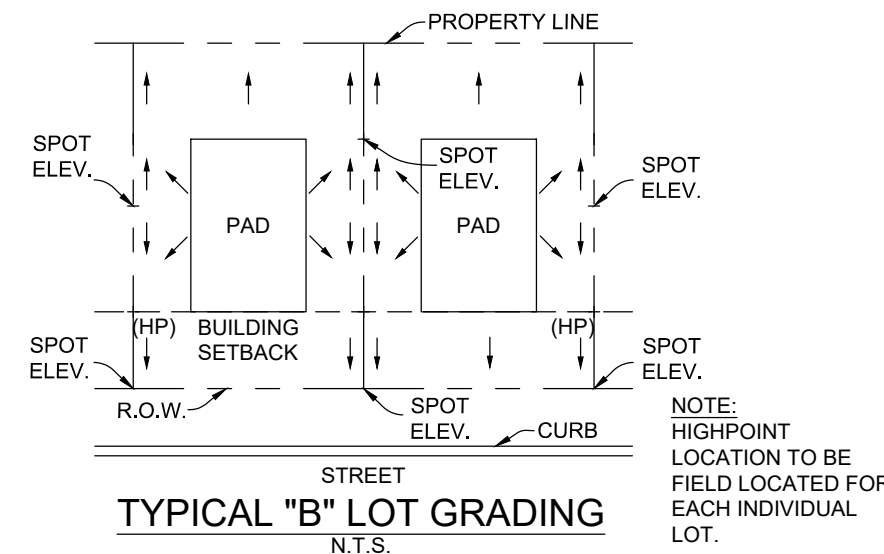
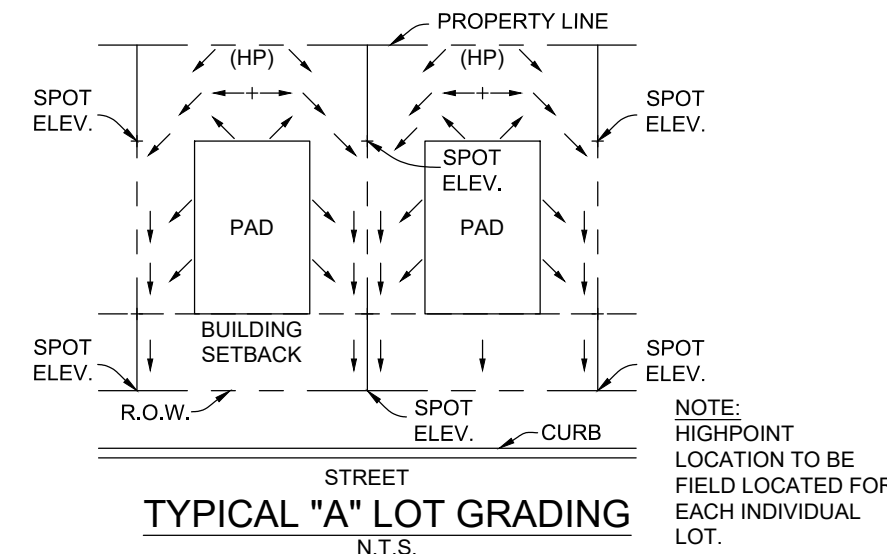

**RETAINING WALL NOTE:**

- CONTRACTOR SHALL HIRE A STRUCTURAL ENGINEER FOR THE DESIGN AND PERMITTING WALLS INCLUDING WITHIN THIS PROJECT.

**RESIDENTIAL GRADING NOTES:**

- DRIVEWAYS MAY BE LOCATED ON EITHER SIDE OF THE LOT UNLESS OTHERWISE SHOWN ON THIS PLAN OR STREET PLANS.
- REFERENCE GRADING NOTES AND GEOTECHNICAL ENGINEERING SPECIFICATIONS PROVIDED BY THE OWNER.
- LOT GRADING PATTERNS (A, B, OR C) MUST BE FOLLOWED.
- ALL LOTS SHALL BE GRADED SO THAT NO DRAINAGE SHALL BE ALLOWED TO FLOW ONTO ADJACENT SIDE LOTS.
- BUILDER TO VERIFY INVERTS OF ALL SANITARY SEWER LATERALS WHEN ESTABLISHING THE APPROPRIATE FINISHED FLOOR ELEVATIONS IN ORDER TO ENSURE ADEQUATE DRAINAGE OF HOUSE LATERALS.
- EXISTING CONTOURS SHOWN ON SITE ARE FROM LIDAR TOPOGRAPHY & FIELD SURVEY.
- GRADES, SLOPES, AND ELEVATIONS SHOWN ARE MASS GRADES ONLY. BUILDER SHALL BE RESPONSIBLE FOR CONSTRUCTION OF SIDE YARD SWALES AND DETAILED GRADING AROUND EACH INDIVIDUAL HOUSE ENSURING POSITIVE DRAINAGE IN EACH CASE.

**GRADING NOTES:**

- ALL MATERIALS AND CONSTRUCTION PROCEDURES WITHIN THIS SCOPE OF WORK WHERE NOT SPECIFICALLY COVERED IN THE SPECIFICATIONS OR GEOTECHNICAL REPORT SHALL CONFORM TO ALL APPLICABLE CITY, COUNTY AND TxDOT STANDARD SPECIFICATIONS FOR PUBLIC WORKS CONSTRUCTION (LATEST EDITION).
- SITE PREPARATION, GRADING, EXCAVATION AND FILL SHALL BE PERFORMED IN ACCORDANCE WITH THE PROJECT GEOTECHNICAL REPORT AND SPECIFICATIONS.
- ALL SELECT FILL MATERIAL PROVIDED SHALL BE APPROVED BY THE GEOTECHNICAL ENGINEER PRIOR TO PLACING AND COMPACTING.
- ALL ELEVATIONS AND PROPOSED CONTOURS SHOWN ON THIS GRADING PLAN REFLECT FINISHED GRADES. THE THICKNESS OF PAVING, BASE, GRASS, TOPSOIL, AND MULCH MUST BE SUBTRACTED TO OBTAIN SUBGRADE ELEVATIONS.
- THE CONTRACTOR SHALL IMMEDIATELY NOTIFY THE ENGINEER OF ANY QUESTIONS THAT MAY ARISE CONCERNING THE INTENT, PLACEMENT, OR LIMITS OF DIMENSIONS OR GRADES NECESSARY FOR CONSTRUCTION OF THIS PROJECT.
- THE CONTRACTOR SHALL VERIFY THE SUITABILITY OF ALL EXISTING AND PROPOSED SITE CONDITIONS INCLUDING GRADES AND DIMENSIONS BEFORE COMMENCEMENT OF CONSTRUCTION. THE ENGINEER SHALL BE NOTIFIED IMMEDIATELY OF ANY DISCREPANCIES.
- THE CONTRACTOR SHALL BE RESPONSIBLE FOR ACQUIRING ALL PERMITS, TESTS, APPROVALS AND ACCEPTANCES REQUIRED TO COMPLETE CONSTRUCTION OF THIS PROJECT.
- THE CONTRACTOR SHALL REMOVE TOP SOIL, GRASS, ROOTS, DEBRIS, ETC. AND DISPOSE OFF SITE THOSE MATERIALS NOT SUITABLE FOR EMBANKMENT AND TOPSOIL. CLEAN STRIPPINGS AND TOPSOIL MAY BE STOCKPILED ON SITE FOR REUSE IN A LOCATION SPECIFIED BY THE OWNER.
- THE SITE CONTRACTOR SHALL BE RESPONSIBLE FOR SITE STABILIZATION. ALL DISTURBED AREAS SHALL BE REVEGETATED IN ACCORDANCE WITH PROJECT SPECIFICATIONS AND SWPPP REQUIREMENTS. REFERENCE THE LANDSCAPE ARCHITECT'S PLAN, IF APPLICABLE.
- THE CONTRACTOR SHALL TAKE ALL NECESSARY PRECAUTIONS (USE OF SILT FENCES, ETC.) TO KEEP DRAINAGE AND SILT FROM WASHING ONTO ADJACENT PROPERTY, STREETS, OR DRAINAGE WAYS. CONTRACTOR SHALL IMMEDIATELY REMOVE SILT/DEBRIS WHICH WASHES OFFSITE OR INTO EXISTING STORM DRAIN SYSTEMS. (SEE SWPPP PLANS & TPOES BOOK).
- THE CONTRACTOR SHALL OBTAIN GRADES SHOWN HEREON WITHIN +/- ONE-TENTH (0.10) FOOT.
- IN PROPOSED PAVING AREAS, STREET DESIGN PLANS SHALL CONTROL. ALL EARTHEN SLOPES SHALL BE A MAXIMUM OF 3:1 AND A MINIMUM OF 1.0% UNLESS OTHERWISE SHOWN.
- THE CONTRACTOR SHALL PROVIDE A SMOOTH TRANSITION BETWEEN EXISTING SITE AND PROPOSED IMPROVEMENTS.
- THE CONTRACTOR SHALL BE RESPONSIBLE FOR RESTORING TO ITS ORIGINAL OR BETTER, CONDITION ANY DAMAGE DONE TO EXISTING TREES, BUILDINGS, UTILITIES, FENCES, PAVEMENT, CURBS, OR DRIVEWAYS (NO SEPARATE PAY ITEMS).
- THE CONTRACTOR SHALL EXERCISE EXTREME CAUTION IN WORKING NEAR UTILITIES, GAS LINES, SEWER, OR EXISTING APURTANCES. PRIOR TO PERFORMING ANY EXCAVATION, CONTRACTOR SHALL CONTACT ALL UTILITY COMPANIES AND ASSURE HIMSELF THAT ALL UTILITIES HAVE BEEN ADEQUATELY LOCATED AND IDENTIFIED. THE ENGINEER SHALL BE NOTIFIED IF ANY UTILITY CONFLICTS ARE DISCOVERED.
- UTILITIES SHOWN ON THE PLANS ARE FROM INFORMATION SOURCES AVAILABLE AT THE TIME OF DESIGN BUT MAY NOT REPRESENT ALL EXISTING UTILITIES ON SITE. THE CONTRACTOR WILL BE RESPONSIBLE FOR DETERMINING EXACT LOCATION OF ALL UTILITIES WHETHER SHOWN ON THE PLANS OR NOT. THE CONTRACTOR SHALL UNCOVER EXISTING UTILITIES PRIOR TO CONSTRUCTION AND VERIFY SIZE, GRADE AND LOCATION. THE CONTRACTOR SHALL NOTIFY THE ENGINEER IMMEDIATELY OF ANY DEVIATIONS FROM PLANS PRIOR TO BEGINNING CONSTRUCTION. ANY DAMAGE TO EXISTING UTILITIES, WHETHER SHOWN ON THE PLANS OR NOT, SHALL BE THE CONTRACTOR'S RESPONSIBILITY TO REPAIR, AT HIS OWN EXPENSE.
- POSITIVE DRAINAGE SHALL BE MAINTAINED THROUGHOUT THE SCOPE OF THE PROJECT. DRAINAGE SHALL BE DIRECTED AWAY FROM ALL BUILDING FOUNDATIONS. CONTRACTOR SHOULD TAKE PRECAUTIONS NOT TO ALLOW ANY PONDING OF WATER.
- FOR FILL PLACEMENT ON HILL SIDES OR STEEP SLOPE AREAS, THE CONTRACTOR SHALL REFERENCE THE PROJECT SPECIFICATIONS AND GEOTECHNICAL REPORT FOR SPECIAL INSTRUCTIONS REGARDING BENCHING.
- NO WORK SHALL BE PERFORMED IN A PUBLIC RIGHT-OF-WAY WITHOUT A PERMIT.
- STRIPPING OF VEGETATION FROM PROJECT SITES SHALL BE PHASED SO AS TO EXPOSE THE MINIMUM AMOUNT OF AREA TO SOIL EROSION FOR THE SHORTEST POSSIBLE PERIOD OF TIME PER THE NEW BRAUNFELS DRAINAGE AND EROSION CONTROL DESIGN MANUAL, SEC. 12.2(4).

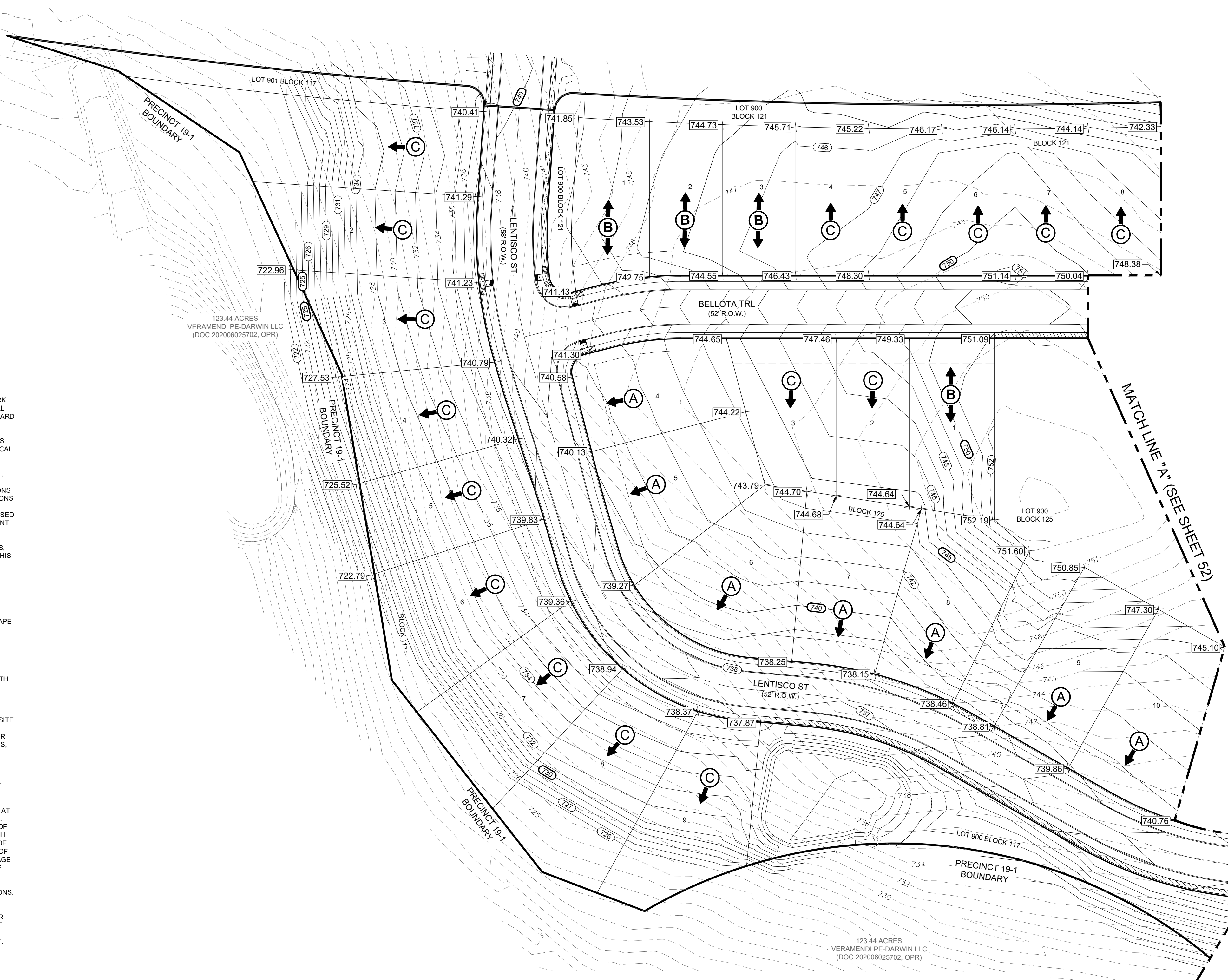

**LEGEND**

PROPOSED	EXISTING	DESCRIPTION
		CONTOUR
		FLOW ARROW
		GRASSED DRAIN FLOW
		GROUND ELEVATION
		MATCH EXISTING GROUND
		LOT DRAINS TO FRONT
		LOT DRAINS 1/2 TO FRONT AND 1/2 TO REAR
		LOT DRAINS TO REAR
		LOT TYPE A MODIFIED
		LOT TYPE B MODIFIED
		LOT TYPE C MODIFIED
		TOP OF MANHOLE
		EXISTING
		GAS, ELEC, TELE & CABLE TV ESMT.
		EASEMENT
		VOLUME
		PAGE
		SIGNIFICANT TREE PRESERVED
		HERITAGE TREE PRESERVED

VERAMENDI PRECINCT 19 UNIT 1  
GRADING PLAN (SHEET 1 OF 3)

NO.	DATE	DESCRIPTION

DATE: 11/02/2023  
DESIGNED BY: NG  
DRAWN BY: TM  
CHECKED BY: PF  
DRAWING NAME: 19\_1\_Grading.dwg

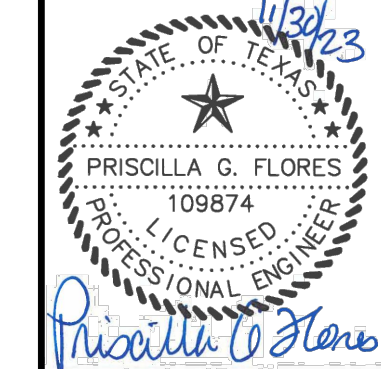

**LJA Engineering, Inc.**  
9830 Colonnade Blvd  
Suite 300  
San Antonio, Texas 78230

Phone 210.503.2700  
LJA.COM  
TBP# No. F-1386

JOB NUMBER: SA3856.0401  
SHEET NO. 51 OF 61 SHEETS

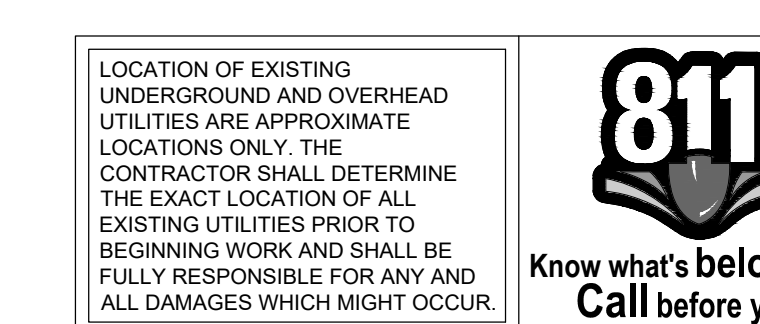

LOCATION OF EXISTING UNDERGROUND AND OVERHEAD UTILITIES ARE APPROXIMATE LOCATIONS ONLY. THE CONTRACTOR SHALL DETERMINE THE EXACT LOCATION OF ALL EXISTING UTILITIES PRIOR TO BEGINNING WORK AND SHALL BE FULLY RESPONSIBLE FOR ANY AND ALL DAMAGES WHICH MIGHT OCCUR.

FOR PERMIT

K:\GIS\BIBI\_ACSA\_Progress\19-1\19-1\_V203\_Site\_Development\19-1\_V203\_Site\_Development\19-1\_V203\_Site\_Development\19-1\_V203\_Site\_Development.dwg  
Last Modified: Nov 02, 2023 10:20:08 AM  
Plot Date: 11/02/2023 10:20:08 AM

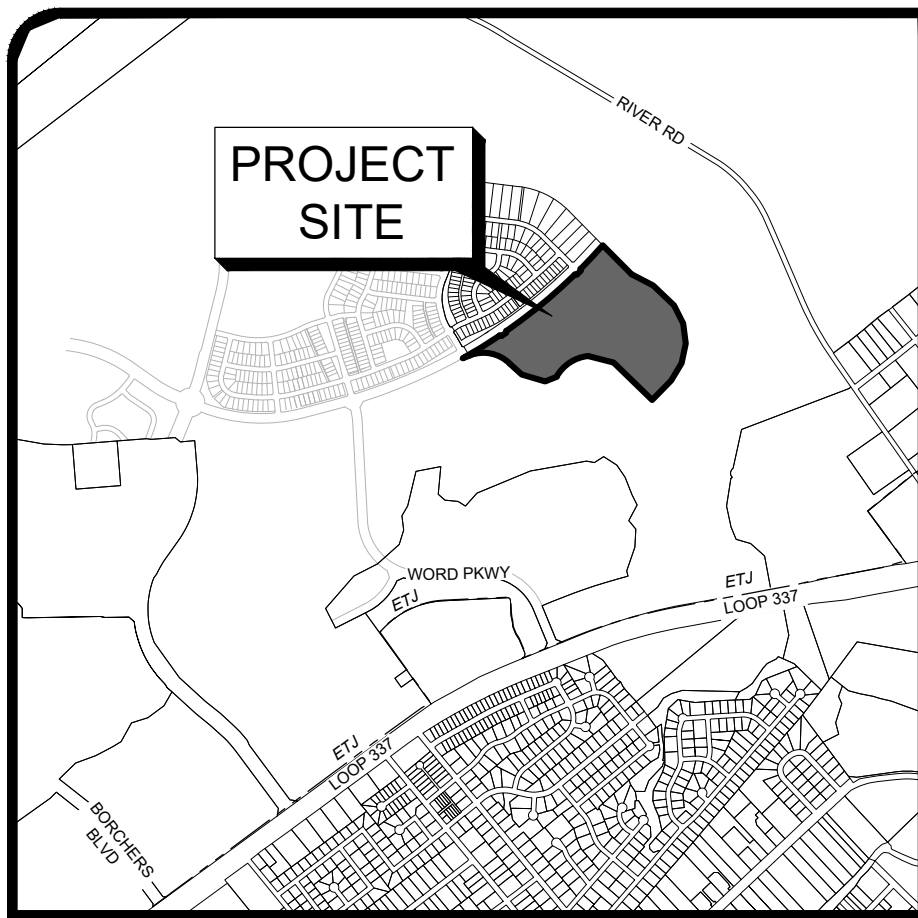

LOCATION MAP  
SCALE: 1" = 2000'

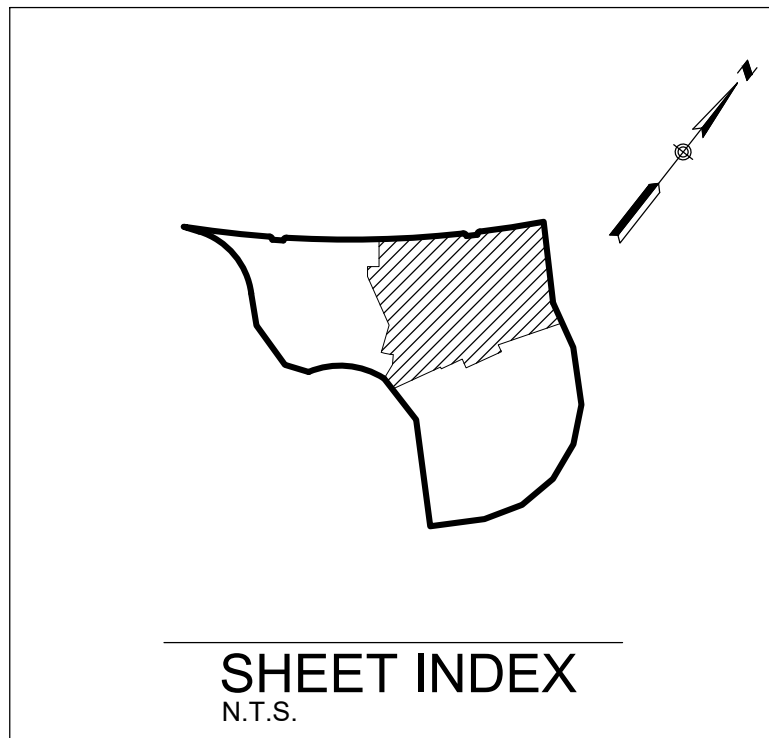

SHEET INDEX  
N.T.S.

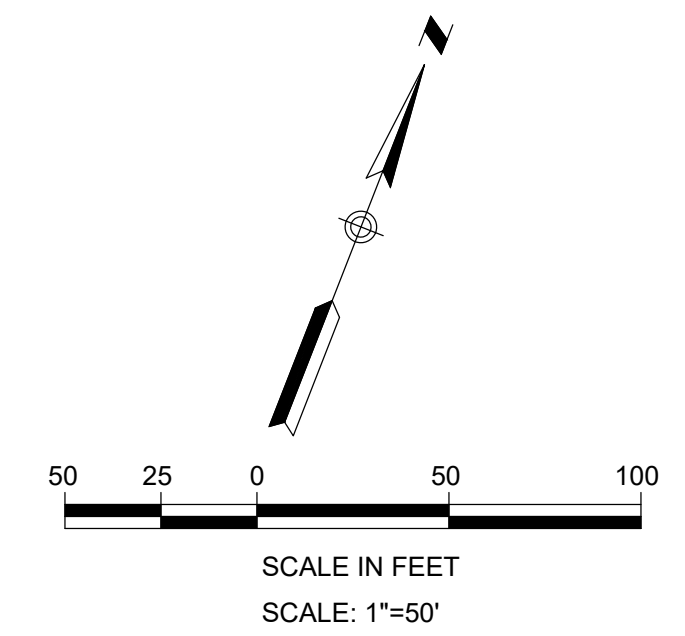
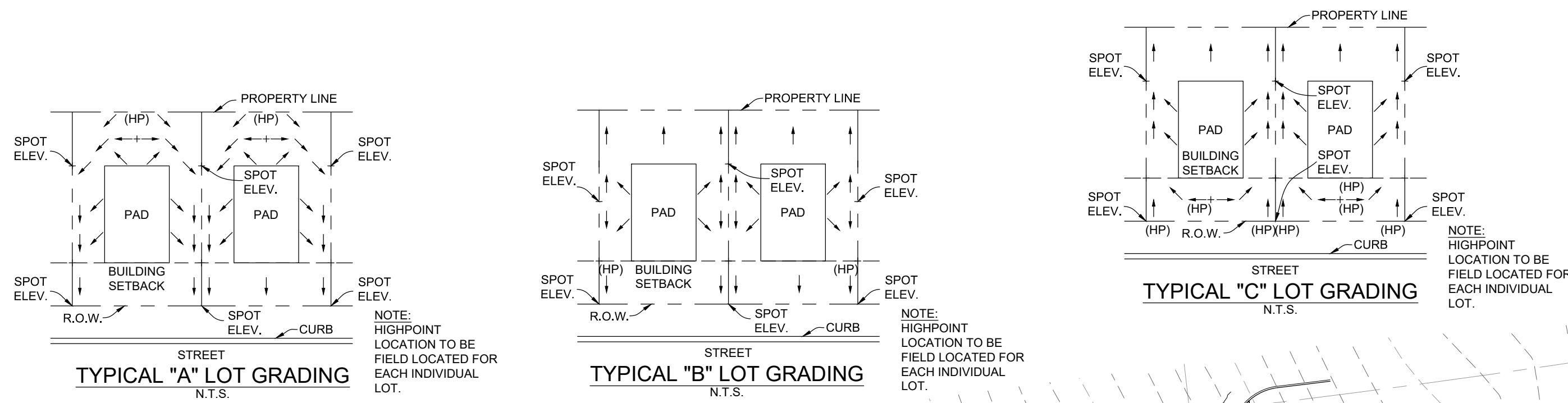

**GRADING NOTES:**

- ALL MATERIALS AND CONSTRUCTION PROCEDURES WITHIN THIS SCOPE OF WORK WHERE NOT SPECIFICALLY COVERED IN THE SPECIFICATIONS OR GEOTECHNICAL REPORT SHALL CONFORM TO ALL APPLICABLE CITY, COUNTY AND TxDOT STANDARD SPECIFICATIONS FOR PUBLIC WORKS CONSTRUCTION (LATEST EDITION).
- SITE PREPARATION, GRADING, EXCAVATION AND FILL SHALL BE PERFORMED IN ACCORDANCE WITH THE PROJECT GEOTECHNICAL REPORT AND SPECIFICATIONS.
- ALL SELECT FILL MATERIAL PROVIDED SHALL BE APPROVED BY THE GEOTECHNICAL ENGINEER PRIOR TO PLACING AND COMPACTING.
- ALL ELEVATIONS AND PROPOSED CONTOURS SHOWN ON THIS GRADING PLAN REFLECT FINISHED GRADES. THE THICKNESS OF PAVING, BASE, GRASS, TOPSOIL, AND MULCH MUST BE SUBTRACTED TO OBTAIN SUBGRADE ELEVATIONS.
- THE CONTRACTOR SHALL IMMEDIATELY NOTIFY THE ENGINEER OF ANY QUESTIONS THAT MAY ARISE CONCERNING THE INTENT, PLACEMENT, OR LIMITS OF DIMENSIONS OR GRADES NECESSARY FOR CONSTRUCTION OF THIS PROJECT.
- THE CONTRACTOR SHALL VERIFY THE SUITABILITY OF ALL EXISTING AND PROPOSED SITE CONDITIONS INCLUDING GRADES AND DIMENSIONS BEFORE COMMENCEMENT OF CONSTRUCTION. THE ENGINEER SHALL BE NOTIFIED IMMEDIATELY OF ANY DISCREPANCIES.
- THE CONTRACTOR SHALL BE RESPONSIBLE FOR ACQUIRING ALL PERMITS, TESTS, APPROVALS AND ACCEPTANCES REQUIRED TO COMPLETE CONSTRUCTION OF THIS PROJECT.
- THE CONTRACTOR SHALL REMOVE TOP SOIL, GRASS, ROOTS, DEBRIS, ETC. AND DISPOSE OFF SITE THOSE MATERIALS NOT SUITABLE FOR EMBANKMENT AND TOPSOIL. CLEAN STRIPPINGS AND TOPSOIL MAY BE STOCKPILED ON SITE FOR REUSE IN A LOCATION SPECIFIED BY THE OWNER.
- THE SITE CONTRACTOR SHALL BE RESPONSIBLE FOR SITE STABILIZATION. ALL DISTURBED AREAS SHALL BE REVEGETATED IN ACCORDANCE WITH PROJECT SPECIFICATIONS AND TPDES/SWPPP REQUIREMENTS. REFERENCE THE LANDSCAPE ARCHITECT'S PLAN, IF APPLICABLE.
- THE CONTRACTOR SHALL TAKE ALL NECESSARY PRECAUTIONS (USE OF SILT FENCES, ETC.) TO KEEP DRAINAGE AND SILT FROM WASHING ONTO ADJACENT PROPERTY, STREETS, OR DRAINAGE WAYS. CONTRACTOR SHALL IMMEDIATELY REMOVE SILT/DEBRIS WHICH WASHES OFFSITE OR INTO EXISTING STORM DRAIN SYSTEMS. (SEE SWPPP PLANS & TPDES BOOK).
- THE CONTRACTOR SHALL OBTAIN GRADES SHOWN HEREON WITHIN +/- ONE-TENTH (0.10) FOOT.
- IN PROPOSED PAVING AREAS, STREET DESIGN PLANS SHALL CONTROL. ALL EARTHEN SLOPES SHALL BE A MAXIMUM OF 3:1 AND A MINIMUM OF 1:0% UNLESS OTHERWISE SHOWN.
- THE CONTRACTOR SHALL PROVIDE A SMOOTH TRANSITION BETWEEN EXISTING SITE AND PROPOSED IMPROVEMENTS.
- THE CONTRACTOR SHALL BE RESPONSIBLE FOR RESTORING TO ITS ORIGINAL OR BETTER, CONDITION ANY DAMAGE DONE TO EXISTING TREES, UTILITIES, FENCES, PAVEMENT, CURBS, OR DRIVEWAYS (NO SEPARATE PAY ITEMS).
- THE CONTRACTOR SHALL EXERCISE EXTREME CAUTION IN WORKING NEAR UTILITIES, GAS LINES, SEWER, OR EXISTING APPURTENANCES. PRIOR TO PERFORMING ANY EXCAVATION, CONTRACTOR SHALL CONTACT ALL UTILITY COMPANIES AND ASSURE HIMSELF THAT ALL UTILITIES HAVE BEEN ADEQUATELY LOCATED AND IDENTIFIED. THE ENGINEER SHALL BE NOTIFIED IF ANY UTILITY CONFLICTS ARE DISCOVERED.
- UTILITIES SHOWN ON THE PLANS ARE FROM INFORMATION SOURCES AVAILABLE AT THE TIME OF DESIGN BUT MAY NOT REPRESENT ALL EXISTING UTILITIES ON SITE. THE CONTRACTOR WILL BE RESPONSIBLE FOR DETERMINING EXACT LOCATION OF ALL UTILITIES WHETHER SHOWN ON THE PLANS OR NOT. THE CONTRACTOR SHALL UNCOVER EXISTING UTILITIES PRIOR TO CONSTRUCTION AND VERIFY SIZE, GRADE AND LOCATION. THE CONTRACTOR SHALL NOTIFY THE ENGINEER IMMEDIATELY OF ANY DEVIATIONS FROM PLANS PRIOR TO BEGINNING CONSTRUCTION. ANY DAMAGE TO EXISTING UTILITIES, WHETHER SHOWN ON THE PLANS OR NOT, SHALL BE THE CONTRACTOR'S RESPONSIBILITY TO REPAIR, AT HIS OWN EXPENSE.
- POSITIVE DRAINAGE SHALL BE MAINTAINED THROUGHOUT THE SCOPE OF THE PROJECT. DRAINAGE SHALL BE DIRECTED AWAY FROM ALL BUILDING FOUNDATIONS. CONTRACTOR SHOULD TAKE PRECAUTIONS NOT TO ALLOW ANY PONDING OF WATER.
- FOR FILL PLACEMENT ON HILL SIDES OR STEEP SLOPE AREAS, THE CONTRACTOR SHALL REFERENCE THE PROJECT SPECIFICATIONS AND GEOTECHNICAL REPORT FOR SPECIAL INSTRUCTIONS REGARDING BENCHING.
- NO WORK SHALL BE PERFORMED IN A PUBLIC RIGHT-OF-WAY WITHOUT A PERMIT.
- STRIPPING OF VEGETATION FROM PROJECT SITES SHALL BE PHASED SO AS TO EXPOSE THE MINIMUM AMOUNT OF AREA TO SOIL EROSION FOR THE SHORTEST POSSIBLE PERIOD OF TIME PER THE NEW BRAUNFELS DRAINAGE AND EROSION CONTROL DESIGN MANUAL SEC.12.2(N).

**RETAINING WALL NOTE:**

- CONTRACTOR SHALL HIRE A STRUCTURAL ENGINEER FOR THE DESIGN AND PERMITTING WALLS INCLUDING WITHIN THIS PROJECT.

**RESIDENTIAL GRADING NOTES:**

- DRIVEWAYS MAY BE LOCATED ON EITHER SIDE OF THE LOT UNLESS OTHERWISE SHOWN ON THIS PLAN OR STREET PLANS.
- REFERENCE GRADING NOTES AND GEOTECHNICAL ENGINEERING SPECIFICATIONS PROVIDED BY THE OWNER.
- LOT GRADING PATTERNS (A, B, OR C) MUST BE FOLLOWED.
- ALL LOTS SHALL BE GRADED SO THAT NO DRAINAGE SHALL BE ALLOWED TO FLOW ONTO ADJACENT SIDE LOTS.
- BUILDER TO VERIFY INVERTS OF ALL SANITARY SEWER LATERALS WHEN ESTABLISHING THE APPROPRIATE FINISHED FLOOR ELEVATIONS IN ORDER TO ENSURE ADEQUATE DRAINAGE OF HOUSE LATERALS.
- EXISTING CONTOURS SHOWN ONSITE ARE FROM LIDAR TOPOGRAPHY & FIELD SURVEY.
- GRADES, SLOPES, AND ELEVATIONS SHOWN ARE MASS GRADES ONLY. BUILDER SHALL BE RESPONSIBLE FOR CONSTRUCTION OF SIDE YARD SWALES AND DETAILED GRADING AROUND EACH INDIVIDUAL HOUSE ENSURING POSITIVE DRAINAGE IN EACH CASE.

**LEGEND**

PROPOSED	EXISTING	DESCRIPTION
		CONTOUR
		FLOW ARROW
		GRASSED DRAIN FLOW
		GROUND ELEVATION
		MATCH EXISTING GROUND
		LOT DRAINS TO FRONT
		LOT DRAINS 1/2 TO FRONT AND 1/2 TO REAR
		LOT DRAINS TO REAR
		LOT TYPE A MODIFIED
		LOT TYPE B MODIFIED
		LOT TYPE C MODIFIED
		TOP OF MANHOLE
		EXISTING
		GAS, ELEC, TELE & CABLE TV ESMT
		EASEMENT
		VOLUME
		PAGE
		SIGNIFICANT TREE PRESERVED
		HERITAGE TREE PRESERVED

LOCATION OF EXISTING UNDERGROUND AND OVERHEAD UTILITIES ARE APPROXIMATE LOCATIONS ONLY. THE CONTRACTOR SHALL DETERMINE THE EXACT LOCATION OF ALL EXISTING UTILITIES PRIOR TO BEGINNING WORK AND SHALL BE FULLY RESPONSIBLE FOR ANY AND ALL DAMAGES WHICH MIGHT OCCUR.

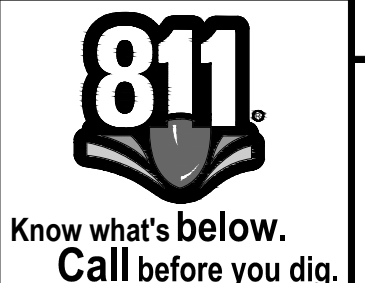

NO.	REVISIONS DESCRIPTION	DATE	BY

DATE: 11/29/2023  
DESIGNED BY: NG  
DRAWN BY: TM  
CHECKED BY: PF  
DRAWING NAME: 19\_Grading.dwg

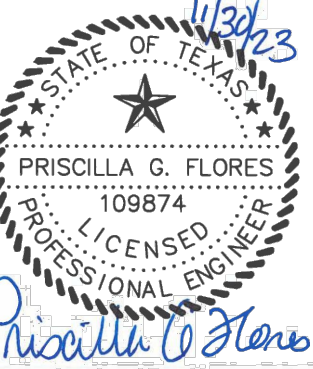

**LJA Engineering, Inc.**  
Phone 210.603.2700  
9830 Calumet Blvd  
Suite 300  
San Antonio, Texas 78230

JOB NUMBER: SA3856.0401  
SHEET NO. 52 OF 61 SHEETS

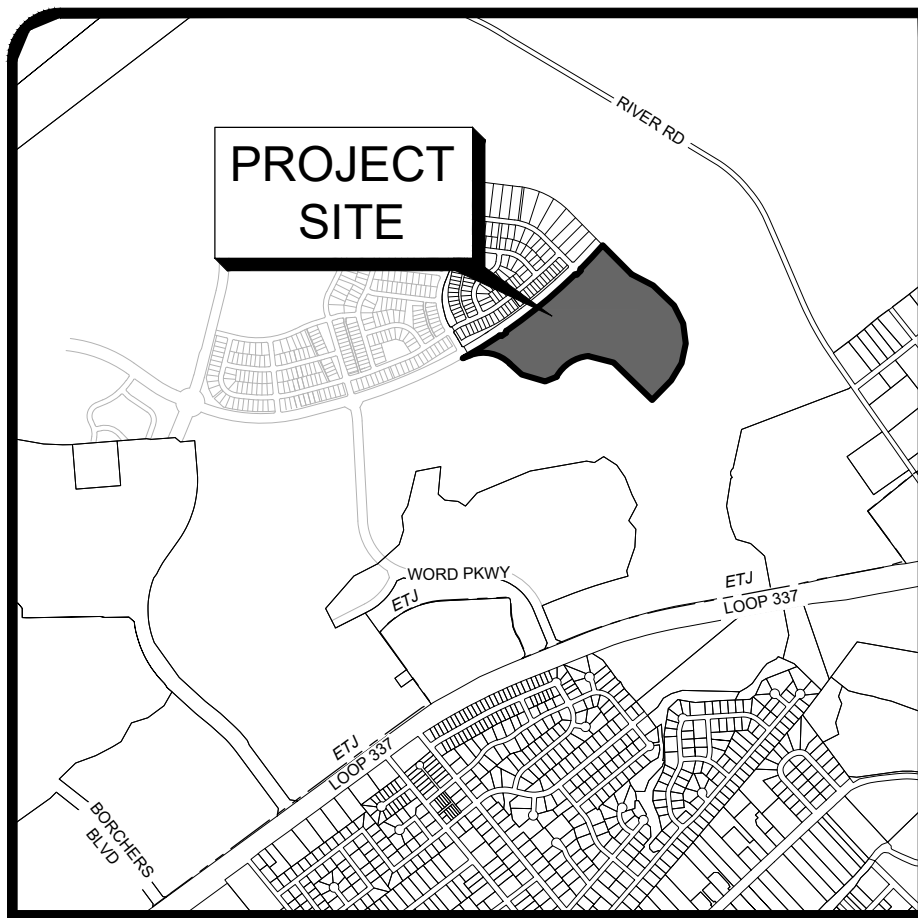

**LOCATION MAP**  
SCALE: 1" = 2000'

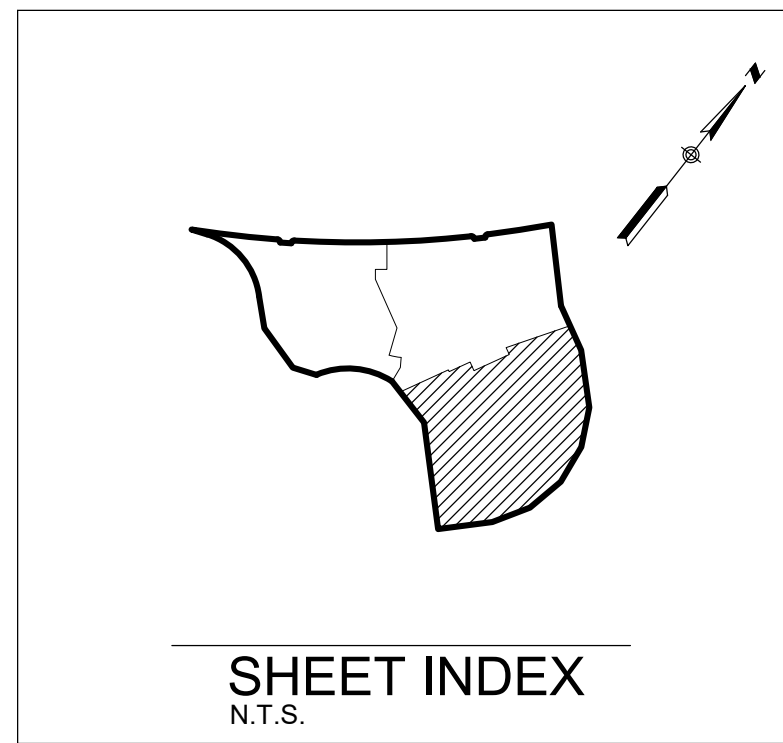

**SHEET INDEX**  
N.T.S.

LOCATION OF EXISTING UNDERGROUND AND OVERHEAD UTILITIES ARE APPROXIMATE LOCATIONS ONLY. THE CONTRACTOR SHALL DETERMINE THE EXACT LOCATION OF ALL EXISTING UTILITIES PRIOR TO BEGINNING WORK AND SHALL BE FULLY RESPONSIBLE FOR ANY AND ALL DAMAGES WHICH MIGHT OCCUR.

**811**  
Know what's below.  
Call before you dig.

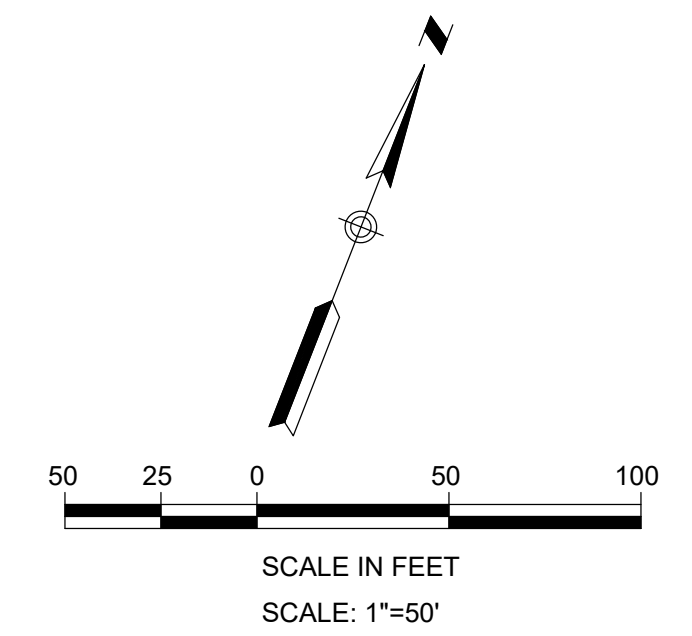

**RETAINING WALL NOTE:**

1. CONTRACTOR SHALL HIRE A STRUCTURAL ENGINEER FOR THE DESIGN AND PERMITTING WALLS INCLUDING WITHIN THIS PROJECT.

**RESIDENTIAL GRADING NOTES:**

- DRIVEWAYS MAY BE LOCATED ON EITHER SIDE OF THE LOT UNLESS OTHERWISE SHOWN ON THIS PLAN OR STREET PLANS.
- REFERENCE GRADING NOTES AND GEOTECHNICAL ENGINEERING SPECIFICATIONS PROVIDED BY THE OWNER. LOT GRADING PATTERNS (A, B, OR C) MUST BE FOLLOWED.
- ALL LOTS SHALL BE GRADED SO THAT NO DRAINAGE SHALL BE ALLOWED TO FLOW ONTO ADJACENT SIDE LOTS.
- BUILDER TO VERIFY INVERTS OF ALL SANITARY SEWER LATERALS WHEN ESTABLISHING THE APPROPRIATE FINISHED FLOOR ELEVATIONS IN ORDER TO ENSURE ADEQUATE DRAINAGE OF HOUSE LATERALS.
- EXISTING CONTOURS SHOWN ON SITE ARE FROM LIDAR TOPOGRAPHY & FIELD SURVEY.
- GRADES, SLOPES, AND ELEVATIONS SHOWN ARE MASS GRADES ONLY. BUILDER SHALL BE RESPONSIBLE FOR CONSTRUCTION OF SIDE YARD SWALES AND DETAILED GRADING AROUND EACH INDIVIDUAL HOUSE ENSURING POSITIVE DRAINAGE IN EACH CASE.

**GRADING NOTES:**

- ALL MATERIALS AND CONSTRUCTION PROCEDURES WITHIN THIS SCOPE OF WORK WHERE NOT SPECIFICALLY COVERED IN THE SPECIFICATIONS OR GEOTECHNICAL REPORT SHALL CONFORM TO ALL APPLICABLE CITY, COUNTY AND TxDOT STANDARD SPECIFICATIONS FOR PUBLIC WORKS CONSTRUCTION (LATEST EDITION).
- SITE PREPARATION, GRADING, EXCAVATION AND FILL SHALL BE PERFORMED IN ACCORDANCE WITH THE PROJECT GEOTECHNICAL REPORT AND SPECIFICATIONS. ALL SELECT FILL MATERIAL PROVIDED SHALL BE APPROVED BY THE GEOTECHNICAL ENGINEER PRIOR TO PLACING AND COMPACTING.
- ALL ELEVATIONS AND PROPOSED CONTOURS SHOWN ON THIS GRADING PLAN REFLECT FINISHED GRADES. THE THICKNESS OF PAVING, BASE, GRASS, TOPSOIL, AND MULCH MUST BE SUBTRACTED TO OBTAIN SUBGRADE ELEVATIONS.
- THE CONTRACTOR SHALL IMMEDIATELY NOTIFY THE ENGINEER OF ANY QUESTIONS THAT MAY ARISE CONCERNING THE INTENT, PLACEMENT, OR LIMITS OF DIMENSIONS OR GRADES NECESSARY FOR CONSTRUCTION OF THIS PROJECT.
- THE CONTRACTOR SHALL VERIFY THE SUITABILITY OF ALL EXISTING AND PROPOSED SITE CONDITIONS INCLUDING GRADES AND DIMENSIONS BEFORE COMMENCEMENT OF CONSTRUCTION. THE ENGINEER SHALL BE NOTIFIED IMMEDIATELY OF ANY DISCREPANCIES.
- THE CONTRACTOR SHALL BE RESPONSIBLE FOR ACQUIRING ALL PERMITS, TESTS, APPROVALS AND ACCEPTANCES REQUIRED TO COMPLETE CONSTRUCTION OF THIS PROJECT.
- THE CONTRACTOR SHALL REMOVE TOP SOIL, GRASS, ROOTS, DEBRIS, ETC. AND DISPOSE OFF SITE THOSE MATERIALS NOT SUITABLE FOR EMBANKMENT AND TOPSOIL. CLEAN STRIPPINGS AND TOPSOIL MAY BE STOCKPILED ON SITE FOR REUSE IN A LOCATION SPECIFIED BY THE OWNER.
- THE SITE CONTRACTOR SHALL BE RESPONSIBLE FOR SITE STABILIZATION. ALL DISTURBED AREAS SHALL BE REVEGETATED IN ACCORDANCE WITH PROJECT SPECIFICATIONS AND TPDES/SWPPP REQUIREMENTS. REFERENCE THE LANDSCAPE ARCHITECT'S PLAN, IF APPLICABLE.
- THE CONTRACTOR SHALL TAKE ALL NECESSARY PRECAUTIONS (USE OF SILT FENCES, ETC.) TO KEEP DRAINAGE AND SILT FROM WASHING ONTO ADJACENT PROPERTY, STREETS, OR DRAINAGE WAYS. CONTRACTOR SHALL IMMEDIATELY REMOVE SILT/DEBRIS WHICH WASHES OFFSITE OR INTO EXISTING STORM DRAIN SYSTEMS. (SEE SWPPP PLANS & TPDES BOOK).
- THE CONTRACTOR SHALL OBTAIN GRADES SHOWN HEREON WITHIN +/- ONE-TENTH (0.10) FOOT.
- IN PROPOSED PAVING AREAS, STREET DESIGN PLANS SHALL CONTROL. ALL EARTHEN SLOPES SHALL BE A MAXIMUM OF 3:1 AND A MINIMUM OF 1:0% UNLESS OTHERWISE SHOWN.
- THE CONTRACTOR SHALL PROVIDE A SMOOTH TRANSITION BETWEEN EXISTING SITE AND PROPOSED IMPROVEMENTS.
- THE CONTRACTOR SHALL BE RESPONSIBLE FOR RESTORING TO ITS ORIGINAL OR BETTER, CONDITION ANY DAMAGE DONE TO EXISTING TREES, BUILDINGS, UTILITIES, FENCES, PAVEMENT, CURBS, OR DRIVEWAYS (NO SEPARATE PAY ITEMS).
- THE CONTRACTOR SHALL EXERCISE EXTREME CAUTION IN WORKING NEAR UTILITIES, GAS LINES, SEWER, OR EXISTING APPURTENANCES. PRIOR TO PERFORMING ANY EXCAVATION, CONTRACTOR SHALL CONTACT ALL UTILITY COMPANIES AND ASSURE HIMSELF THAT ALL UTILITIES HAVE BEEN ADEQUATELY LOCATED AND IDENTIFIED. THE ENGINEER SHALL BE NOTIFIED IF ANY UTILITY CONFLICTS ARE DISCOVERED.
- UTILITIES SHOWN ON THE PLANS ARE FROM INFORMATION SOURCES AVAILABLE AT THE TIME OF DESIGN BUT MAY NOT REPRESENT ALL EXISTING UTILITIES ON SITE. THE CONTRACTOR WILL BE RESPONSIBLE FOR DETERMINING EXACT LOCATION OF ALL UTILITIES WHETHER SHOWN ON THE PLANS OR NOT. THE CONTRACTOR SHALL UNCOVER EXISTING UTILITIES PRIOR TO CONSTRUCTION AND VERIFY SIZE, GRADE AND LOCATION. THE CONTRACTOR SHALL NOTIFY THE ENGINEER IMMEDIATELY OF ANY DEVIATIONS FROM PLANS PRIOR TO BEGINNING CONSTRUCTION. ANY DAMAGE TO EXISTING UTILITIES, WHETHER SHOWN ON THE PLANS OR NOT, SHALL BE THE CONTRACTOR'S RESPONSIBILITY TO REPAIR, AT HIS OWN EXPENSE.
- POSITIVE DRAINAGE SHALL BE MAINTAINED THROUGHOUT THE SCOPE OF THE PROJECT. DRAINAGE SHALL BE DIRECTED AWAY FROM ALL BUILDING FOUNDATIONS. CONTRACTOR SHOULD TAKE PRECAUTIONS NOT TO ALLOW ANY PONDING OF WATER.
- FOR FILL PLACEMENT ON HILL SIDES OR STEEP SLOPE AREAS, THE CONTRACTOR SHALL REFERENCE THE PROJECT SPECIFICATIONS AND GEOTECHNICAL REPORT FOR SPECIAL INSTRUCTIONS REGARDING BENCHING.
- NO WORK SHALL BE PERFORMED IN A PUBLIC RIGHT-OF-WAY WITHOUT A PERMIT.
- STRIPPING OF VEGETATION FROM PROJECT SITES SHALL BE PHASED SO AS TO EXPOSE THE MINIMUM AMOUNT OF AREA TO SOIL EROSION OR THE SHORTEST POSSIBLE PERIOD OF TIME PER THE NEW BRAUNFELS DRAINAGE AND EROSION CONTROL DESIGN MANUAL SEC.12.2(N).

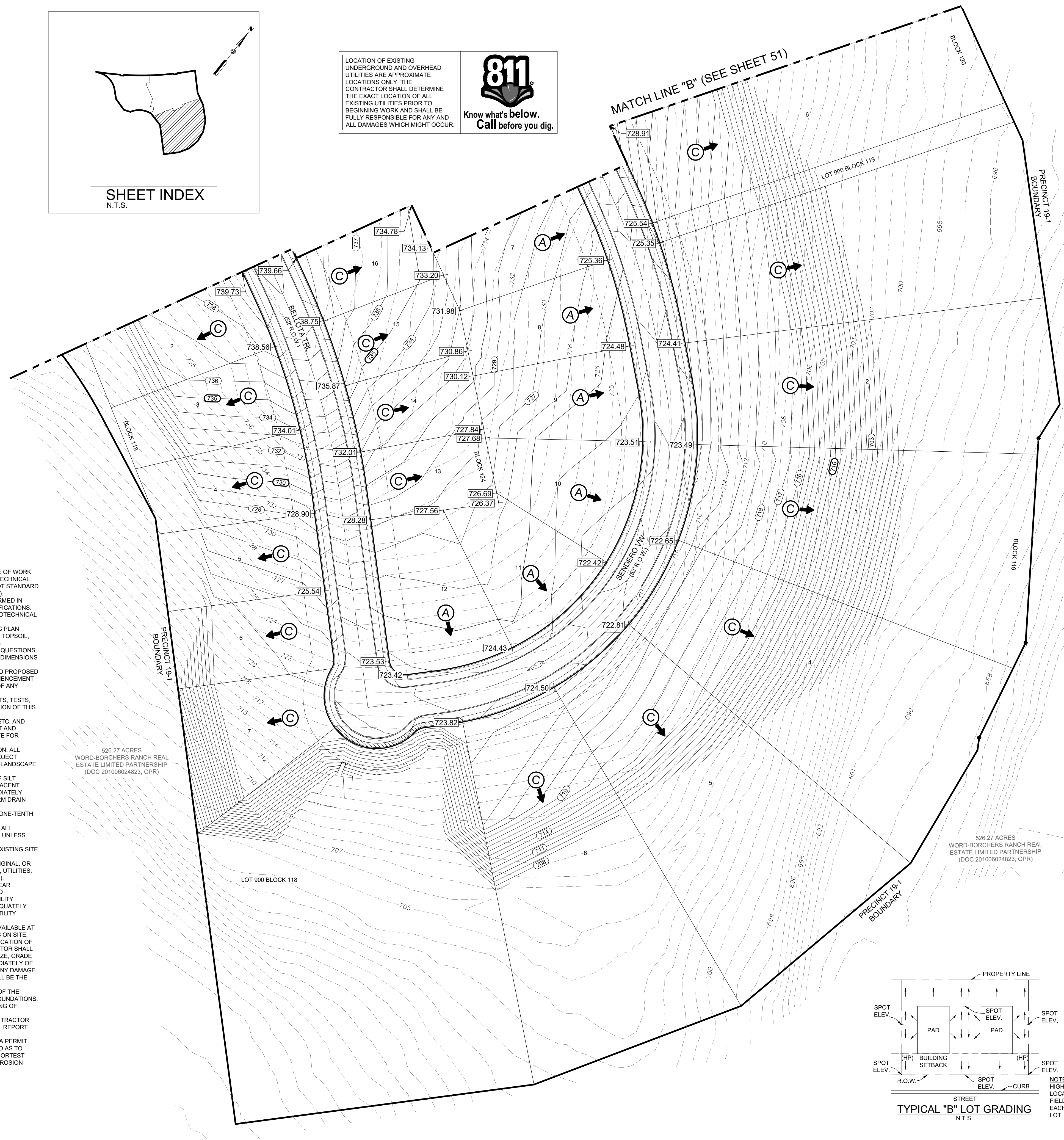

**LEGEND**

PROPOSED	EXISTING	
800	800	CONTOUR
2%	2%	FLOW ARROW
706.41	EG: 801.33	GRASSED DRAIN FLOW
706.41 ME		GROUND ELEVATION
A		MATCH EXISTING GROUND
B		LOT DRAINS TO FRONT
C		LOT DRAINS 1/2 TO FRONT AND 1/2 TO REAR
Am		LOT DRAINS TO REAR
Bm		LOT TYPE A MODIFIED
Cm		LOT TYPE B MODIFIED
		LOT TYPE C MODIFIED
	TMH	TOP OF MANHOLE
	EX.	EXISTING
	G,E,T,CA	GAS, ELEC, TELE & CABLE TV ESMT.
	ESM'T.	EASEMENT
	VOL.	VOLUME
	PG	PAGE
		SIGNIFICANT TREE PRESERVED
		HERITAGE TREE PRESERVED

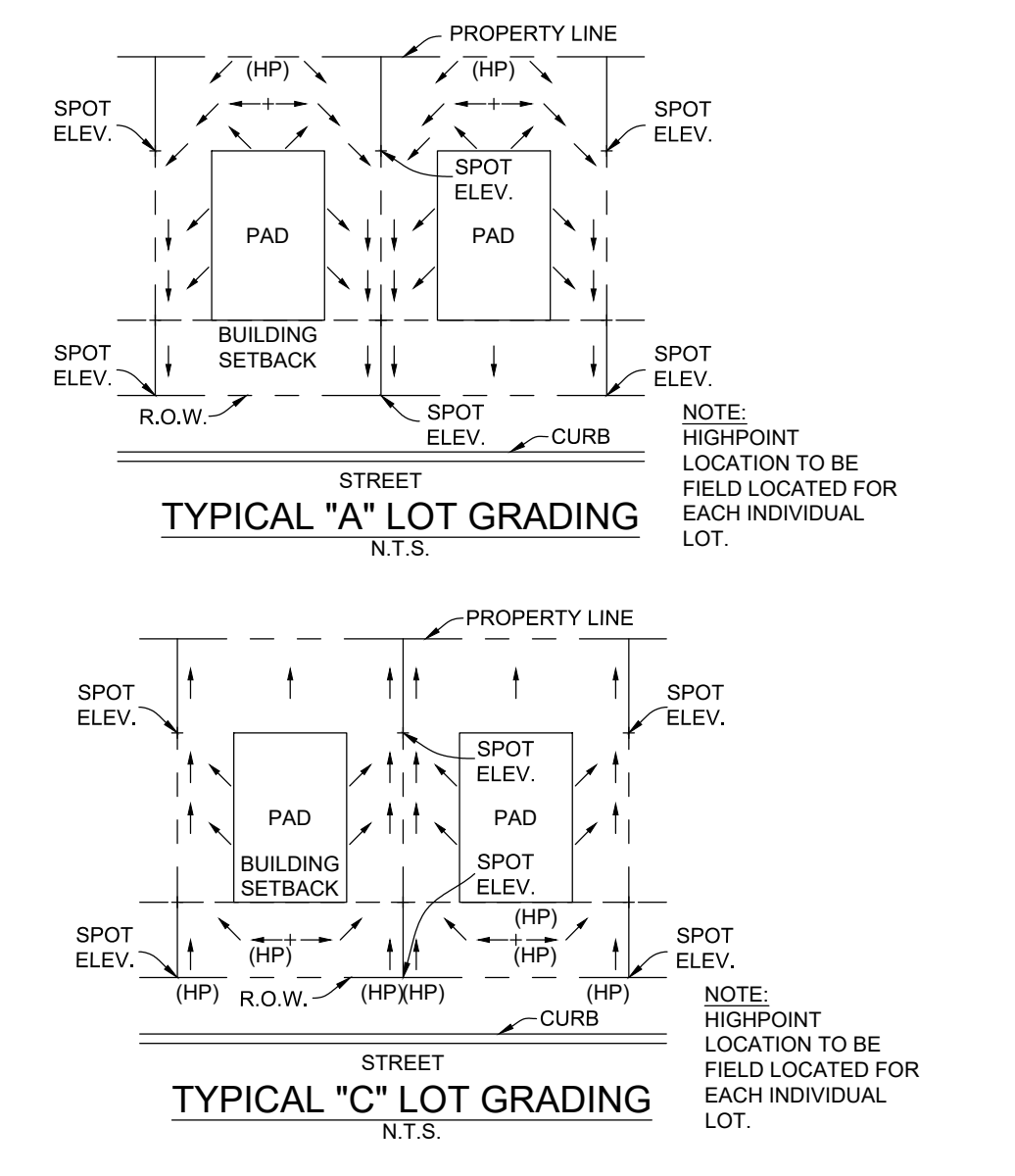

**VERAMENDI PRECINCT 19 UNIT 1**  
GRADING PLAN (SHEET 3 OF 3)

NO.	DATE	BY	REVISIONS DESCRIPTION

DATE: 11/09/2023  
DESIGNED BY: NG  
DRAWN BY: TM  
CHECKED BY: PF  
DRAWING NAME: 811\_Grading.dwg

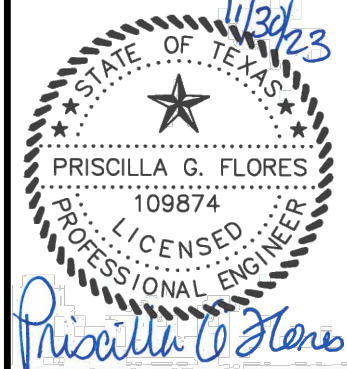

**LJA Engineering, Inc.**  
Phone 210.503.2700  
9830 Callesada Blvd  
Suite 300  
San Antonio, Texas 78230  
LJA.COM  
TBP# No. F-1386

JOB NUMBER: SA3856.0401  
SHEET NO. **53**  
OF 61 SHEETS

K:\AR\BDS\ACA\Progress\0401\_Veramendi Precinct 19-1\401\_Site\Development\Plans\19-1\Sheet3.dwg - 2/23/2024  
Last Modified: Nov 23, 2023 10:20:08 AM  
Plot Date/Time: Nov 23, 2023 10:20:08 AM

# Temporary Stormwater Section

Texas Commission on Environmental Quality

for Regulated Activities on the Edwards Aquifer Recharge Zone and Relating to 30 TAC §213.5(b)(4)(A), (B), (D)(I) and (G); Effective June 1, 1999

*To ensure that the application is administratively complete, confirm that all fields in the form are complete, verify that all requested information is provided, consistently reference the same site and contact person in all forms in the application, and ensure forms are signed by the appropriate party.*

*Note: Including all the information requested in the form and attachments contributes to more streamlined technical reviews.*

## Signature

To the best of my knowledge, the responses to this form accurately reflect all information requested concerning the proposed regulated activities and methods to protect the Edwards Aquifer. This **Temporary Stormwater Section** is hereby submitted for TCEQ review and executive director approval. The application was prepared by:

Print Name of Customer/Agent: Priscilla G. Flores, PE

Date: 3/7/2024

Signature of Customer/Agent:



Regulated Entity Name: Veramendi Precincts 18-2 & 19-1

## Project Information

### Potential Sources of Contamination

*Examples: Fuel storage and use, chemical storage and use, use of asphaltic products, construction vehicles tracking onto public roads, and existing solid waste.*

1. Fuels for construction equipment and hazardous substances which will be used during construction:

The following fuels and/or hazardous substances will be stored on the site: \_\_\_\_\_

These fuels and/or hazardous substances will be stored in:

- Aboveground storage tanks with a cumulative storage capacity of less than 250 gallons will be stored on the site for less than one (1) year.

- Aboveground storage tanks with a cumulative storage capacity between 250 gallons and 499 gallons will be stored on the site for less than one (1) year.
- Aboveground storage tanks with a cumulative storage capacity of 500 gallons or more will be stored on the site. An Aboveground Storage Tank Facility Plan application must be submitted to the appropriate regional office of the TCEQ prior to moving the tanks onto the project.
- Fuels and hazardous substances will not be stored on the site.
- 2.  **Attachment A - Spill Response Actions.** A site specific description of the measures to be taken to contain any spill of hydrocarbons or hazardous substances is attached.
- 3.  Temporary aboveground storage tank systems of 250 gallons or more cumulative storage capacity must be located a minimum horizontal distance of 150 feet from any domestic, industrial, irrigation, or public water supply well, or other sensitive feature.
- 4.  **Attachment B - Potential Sources of Contamination.** A description of any activities or processes which may be a potential source of contamination affecting surface water quality is attached.

### ***Sequence of Construction***

- 5.  **Attachment C - Sequence of Major Activities.** A description of the sequence of major activities which will disturb soils for major portions of the site (grubbing, excavation, grading, utilities, and infrastructure installation) is attached.
  - For each activity described, an estimate (in acres) of the total area of the site to be disturbed by each activity is given.
  - For each activity described, include a description of appropriate temporary control measures and the general timing (or sequence) during the construction process that the measures will be implemented.
- 6.  Name the receiving water(s) at or near the site which will be disturbed or which will receive discharges from disturbed areas of the project: Blieders Creek

### ***Temporary Best Management Practices (TBMPs)***

*Erosion control examples: tree protection, interceptor swales, level spreaders, outlet stabilization, blankets or matting, mulch, and sod. Sediment control examples: stabilized construction exit, silt fence, filter dikes, rock berms, buffer strips, sediment traps, and sediment basins. Please refer to the Technical Guidance Manual for guidelines and specifications. All structural BMPs must be shown on the site plan.*

- 7.  **Attachment D – Temporary Best Management Practices and Measures.** TBMPs and measures will prevent pollution of surface water, groundwater, and stormwater. The construction-phase BMPs for erosion and sediment controls have been designed to retain sediment on site to the extent practicable. The following information is attached:

- A description of how BMPs and measures will prevent pollution of surface water, groundwater or stormwater that originates upgradient from the site and flows across the site.
  - A description of how BMPs and measures will prevent pollution of surface water or groundwater that originates on-site or flows off site, including pollution caused by contaminated stormwater runoff from the site.
  - A description of how BMPs and measures will prevent pollutants from entering surface streams, sensitive features, or the aquifer.
  - A description of how, to the maximum extent practicable, BMPs and measures will maintain flow to naturally-occurring sensitive features identified in either the geologic assessment, TCEQ inspections, or during excavation, blasting, or construction.
8.  The temporary sealing of a naturally-occurring sensitive feature which accepts recharge to the Edwards Aquifer as a temporary pollution abatement measure during active construction should be avoided.
- Attachment E - Request to Temporarily Seal a Feature.** A request to temporarily seal a feature is attached. The request includes justification as to why no reasonable and practicable alternative exists for each feature.
  - There will be no temporary sealing of naturally-occurring sensitive features on the site.
9.  **Attachment F - Structural Practices.** A description of the structural practices that will be used to divert flows away from exposed soils, to store flows, or to otherwise limit runoff discharge of pollutants from exposed areas of the site is attached. Placement of structural practices in floodplains has been avoided.
10.  **Attachment G - Drainage Area Map.** A drainage area map supporting the following requirements is attached:
- For areas that will have more than 10 acres within a common drainage area disturbed at one time, a sediment basin will be provided.
  - For areas that will have more than 10 acres within a common drainage area disturbed at one time, a smaller sediment basin and/or sediment trap(s) will be used.
  - For areas that will have more than 10 acres within a common drainage area disturbed at one time, a sediment basin or other equivalent controls are not attainable, but other TBMPs and measures will be used in combination to protect down slope and side slope boundaries of the construction area.
  - There are no areas greater than 10 acres within a common drainage area that will be disturbed at one time. A smaller sediment basin and/or sediment trap(s) will be used in combination with other erosion and sediment controls within each disturbed drainage area.

- There are no areas greater than 10 acres within a common drainage area that will be disturbed at one time. Erosion and sediment controls other than sediment basins or sediment traps within each disturbed drainage area will be used.
11.  **Attachment H - Temporary Sediment Pond(s) Plans and Calculations.** Temporary sediment pond or basin construction plans and design calculations for a proposed temporary BMP or measure have been prepared by or under the direct supervision of a Texas Licensed Professional Engineer. All construction plans and design information must be signed, sealed, and dated by the Texas Licensed Professional Engineer. Construction plans for the proposed temporary BMPs and measures are attached.
- N/A
12.  **Attachment I - Inspection and Maintenance for BMPs.** A plan for the inspection of each temporary BMP(s) and measure(s) and for their timely maintenance, repairs, and, if necessary, retrofit is attached. A description of the documentation procedures, recordkeeping practices, and inspection frequency are included in the plan and are specific to the site and/or BMP.
13.  All control measures must be properly selected, installed, and maintained in accordance with the manufacturer's specifications and good engineering practices. If periodic inspections by the applicant or the executive director, or other information indicate a control has been used inappropriately, or incorrectly, the applicant must replace or modify the control for site situations.
14.  If sediment escapes the construction site, off-site accumulations of sediment must be removed at a frequency sufficient to minimize offsite impacts to water quality (e.g., fugitive sediment in street being washed into surface streams or sensitive features by the next rain).
15.  Sediment must be removed from sediment traps or sedimentation ponds not later than when design capacity has been reduced by 50%. A permanent stake will be provided that can indicate when the sediment occupies 50% of the basin volume.
16.  Litter, construction debris, and construction chemicals exposed to stormwater shall be prevented from becoming a pollutant source for stormwater discharges (e.g., screening outfalls, picked up daily).

### ***Soil Stabilization Practices***

*Examples: establishment of temporary vegetation, establishment of permanent vegetation, mulching, geotextiles, sod stabilization, vegetative buffer strips, protection of trees, or preservation of mature vegetation.*

17.  **Attachment J - Schedule of Interim and Permanent Soil Stabilization Practices.** A schedule of the interim and permanent soil stabilization practices for the site is attached.

18.  Records must be kept at the site of the dates when major grading activities occur, the dates when construction activities temporarily or permanently cease on a portion of the site, and the dates when stabilization measures are initiated.
19.  Stabilization practices must be initiated as soon as practicable where construction activities have temporarily or permanently ceased.

### ***Administrative Information***

20.  All structural controls will be inspected and maintained according to the submitted and approved operation and maintenance plan for the project.
21.  If any geologic or manmade features, such as caves, faults, sinkholes, etc., are discovered, all regulated activities near the feature will be immediately suspended. The appropriate TCEQ Regional Office shall be immediately notified. Regulated activities must cease and not continue until the TCEQ has reviewed and approved the methods proposed to protect the aquifer from any adverse impacts.
22.  Silt fences, diversion berms, and other temporary erosion and sediment controls will be constructed and maintained as appropriate to prevent pollutants from entering sensitive features discovered during construction.



# Temporary Stormwater Section

## Attachment A – Spill Response Actions

### ***Spill Prevention and Control***

The objective of this section is to describe measures to prevent or reduce the discharge of pollutants to drainage systems or watercourses from leaks and spills by reducing the chance for spills, stopping the source of spills, containing and cleaning up spills, properly disposing of spill materials, and training employees.

The following steps will help reduce the storm water impacts of leaks and spills:

### ***Education***

- (1) Be aware that different materials pollute in different amounts. Make sure that each employee knows what a “significant spill” is for each material they use, and what is the appropriate response for “significant” and “insignificant” spills. Employees should also be aware of when spill must be reported to the TCEQ. Information available in 30 TAC 327.4 and 40 CFR 302.4.
- (2) Educate employees and subcontractors on potential dangers to humans and the environment from spills and leaks.
- (3) Hold regular meetings to discuss and reinforce appropriate disposal procedures (incorporate into regular safety meetings).
- (4) Establish a continuing education program to indoctrinate new employees.
- (5) Have contractor's superintendent or representative oversee and enforce proper spill prevention and control measures.

### ***General Measures***

- (1) To the extent that the work can be accomplished safely, spills of oil, petroleum products, and substances listed under 40 CFR parts 110,117, and 302, and sanitary and septic wastes should be contained and cleaned up immediately.
- (2) Store hazardous materials and wastes in covered containers and protect from vandalism.
- (3) Place a stockpile of spill cleanup materials where it will be readily accessible.
- (4) Train employees in spill prevention and cleanup.
- (5) Designate responsible individuals to oversee and enforce control measures.

- (6) Spills should be covered and protected from stormwater runoff during rainfall to the extent that it doesn't compromise cleanup activities.
- (7) Do not bury or wash spills with water.
- (8) Store and dispose of used clean up materials, contaminated materials, and recovered spill material that is no longer suitable for the intended purpose in conformance with the provisions in applicable BMPs.
- (9) Do not allow water used for cleaning and decontamination to enter storm drains or watercourses. Collect and dispose of contaminated water in accordance with applicable regulations.
- (10) Contain water overflow or minor water spillage and do not allow it to discharge into drainage facilities or watercourses.
- (11) Place Material Safety Data Sheets (MSDS), as well as proper storage, cleanup, and spill reporting instructions for hazardous materials stored or used on the project site in an open, conspicuous, and accessible location.
- (12) Keep waste storage areas clean, well organized, and equipped with ample cleanup supplies as appropriate for the materials being stored. Perimeter controls, containment structures, covers, and liners should be repaired or replaced as needed to maintain proper function.

### ***Cleanup***

- (1) Clean up leaks and spills immediately.
- (2) Use a rag for small spills on paved surfaces, a damp mop for general cleanup, and absorbent material for larger spills. If the spilled material is hazardous, then the used cleanup materials are also hazardous and must be disposed of as hazardous waste.
- (3) Never hose down or bury dry material spills. Clean up as much of the material as possible and dispose of properly. See the waste management BMPs in this section for specific information.

### ***Minor Spills***

- (1) Minor spills typically involve small quantities of oil, gasoline, paint, etc. which can be controlled by the first responder at the discovery of the spill.
- (2) Use absorbent materials on small spills rather than hosing down or burying the spill.
- (3) Absorbent materials should be promptly removed and disposed of properly.

- (4) Follow the practice below for a minor spill:
  - a) Contain the spread of the spill.
  - b) Recover spilled materials.
  - c) Clean the contaminated area and properly dispose of contaminated materials.

### ***Semi-significant Spills***

Semi-significant spills still can be controlled by the first responder along with the aid of other personnel such as laborers and the foreman, etc. This response may require the cessation of all other activities.

Spills should be cleaned up immediately:

- (1) Contain spread of the spill.
- (2) Notify the project foreman immediately.
- (3) If the spill occurs on paved or impermeable surfaces, clean up using "dry" methods (absorbent materials, cat litter and/or rags). Contain the spill by encircling with absorbent materials and do not let the spill spread widely.
- (4) If the spill occurs in dirt areas, immediately contain the spill by constructing an earthen dike. Dig up and properly dispose of contaminated soil.
- (5) If the spill occurs during rain, cover spill with tarps or other material to prevent contaminating runoff.

### ***Significant/Hazardous Spills***

For significant or hazardous spills that are in reportable quantities:

- (1) Notify the TCEQ by telephone as soon as possible and within 24 hours at 512-339-2929 (Austin) or 210-490-3096 (San Antonio) between 8 AM and 5 PM. After hours, contact the Environmental Release Hotline at 1-800-832-8224. It is the contractor's responsibility to have all emergency phone numbers at the construction site.
- (2) For spills of federal reportable quantities, in conformance with the requirements in 40 CFR parts 110,119, and 302, the contractor should notify the National Response Center at (800) 424-8802.
- (3) Notification should first be made by telephone and followed up with a written report.
- (4) The services of a spills contractor or a Haz-Mat team should be obtained immediately. Construction personnel should not attempt to clean up until the appropriate and qualified staffs have arrived at the job site.

- (5) Other agencies which may need to be consulted include, but are not limited to, the City Police Department, County Sheriff Office, Fire Departments, etc.

More information on spill rules and appropriate responses is available on the TCEQ website at:

[http://www.tnrcc.state.tx.us/enforcement/emergency\\_response.html](http://www.tnrcc.state.tx.us/enforcement/emergency_response.html).

### ***Vehicle and Equipment Maintenance***

- (1) If maintenance must occur onsite, use a designated area and a secondary containment, located away from drainage courses, to prevent the runoff of stormwater and the runoff of spills.
- (2) Regularly inspect onsite vehicles and equipment for leaks and repair immediately.
- (3) Check incoming vehicles and equipment (including delivery trucks, and employee and subcontractor vehicles) for leaking oil and fluids. Do not allow leaking vehicles or equipment onsite.
- (4) Always use secondary containment, such as a drain pan or drop cloth, to catch spills or leaks when removing or changing fluids.
- (5) Place drip pans or absorbent materials under paving equipment when not in use.
- (6) Use absorbent materials on small spills rather than hosing down or burying the spill. Remove the absorbent materials promptly and dispose of properly.
- (7) Promptly transfer used fluids to the proper waste or recycling drums. Don't leave full drip pans or other open containers lying around.
- (8) Oil filters disposed of in trashcans or dumpsters can leak oil and pollute stormwater. Place the oil filter in a funnel over a waste oil-recycling drum to drain excess oil before disposal. Oil filters can also be recycled. Ask the oil supplier or recycler about recycling oil filters.
- (9) Store cracked batteries in a non-leaking secondary container. Do this with all cracked batteries even if you think all the acid has drained out. If you drop a battery, treat it as if it is cracked. Put it into the containment area until you are sure it is not leaking.

### ***Vehicle and Equipment Fueling***

- (1) If fueling must occur on site, use designated areas, located away from drainage courses, to prevent the runoff of stormwater and the runoff of spills.
- (2) Discourage "topping off" of fuel tanks.

- (3) Always use secondary containment, such as a drain pan, when fueling to catch spills/leaks.

***Spill Response Actions***

In the event that a spill of hydrocarbons or hazardous substances does occur, the contractor shall be required to maintain a sufficient stockpile of sand material in the staging area. This sand material shall be used to immediately isolate and provide containment of the spill by constructing dikes. Furthermore, this sand material shall act as an absorbent material that can be disposed of offsite and out of the Recharge Zone during clean-up operations. The contractor, in the event of a spill, shall also notify the owner who shall contact TCEQ. All contaminated soils resulting from an accidental release will be required to be removed and disposed of in accordance with all local, state and federal regulations.

**Attachment B – Potential Sources Contamination**

<b>Potential Source</b>	Oil, grease, fuel and hydraulic fluid contamination from construction equipment and vehicle dripping.
Preventive Measure	Vehicle maintenance, when possible, will be performed within a construction staging area specified by the General Contractor.
<b>Potential Source</b>	Miscellaneous trash and litter from construction workers and material wrappings.
Preventive Measure	Trash containers will be placed throughout the site to encourage proper trash disposal.
<b>Potential Source</b>	Construction debris.
Preventive Measure	Construction debris will be monitored daily by contractor. Debris will be collected weekly and placed in disposal bins. Situations requiring immediate attention will be addressed on a case by case basis.
<b>Potential Source</b>	Stormwater contamination from excess application of fertilizers, herbicides and pesticides.
Preventive Measure	Fertilizers, herbicides and pesticides will be applied only when necessary and in accordance with manufacturer's directions.

<b>Potential Source</b>	Soil and mud from construction vehicle tires as they leave the site.
Preventive Measure	A temporary construction entrance/exit shall be utilized as vehicles leave the site. Any soil, mud, etc. carried from the project onto public roads shall be cleaned up within 24 hours.
<b>Potential Source</b>	Sediment from soil, sand, gravel and excavated materials stockpiled on site.
Preventive Measure	Silt fence shall be installed on the down gradient side of all stockpiled materials. Reinforced rock berms shall be installed at all downstream discharge locations.
<b>Potential Source</b>	Portable toilet spill.
Preventive Measure	Toilets on the site will be emptied on a regular basis by the contracted toilet company.

### **Attachment C – Sequence of Major Activities**

The sequence of major activities which disturb soil during construction on this site will be divided into stages. The first stage is site preparation that will include clearing and grubbing of vegetation, where applicable. This will disturb approximately 88.72 acres. The second is construction that will include installation of utilities, construction of the water quality basin and the proposed buildings, parking lot, landscaping and site cleanup. This will disturb approximately 88.72 acres.

Sequence Item	Description
1.	<b>Install TBMP's as required. (Silt Fence, etc.)</b>
2.	<b>Clearing of Disturbed Areas</b>
3.	<b>Grading of Disturbed Areas</b>
4.	<b>Construction of Permanent BMP's /Storm Drains</b>
5.	<b>Complete Construction</b>
6.	<b>Soil Stabilization and/or re-vegetation</b>
7.	<b>Clean site</b>
8.	<b>Remove TBMP's</b>

## **Attachment D – Temporary Best Management Practices and Measures**

1. Temporary Construction Entrance/Exit – A stabilized pad of crushed stone located at any point where traffic will be entering or leaving the construction site from a public R.O.W., street, alley, sidewalk or parking area. It shall be a minimum of 50 feet long, 12 feet wide and 8 inches thick. The rock shall be 4” to 8” in size.
2. Silt Fence – A barrier consisting of geotextile fabric supported by metal posts to prevent soil and sediment loss from a site. Silt fences shall be installed on the down gradient side of the proposed areas to be disturbed that have a drainage area of ¼ acres per 100 feet of fence.
3. Rock Berms – A sediment trap consisting of 3” to 5” diameter rock wrapped in a woven wire sheathing. The berm shall have a minimum height of 36” and a minimum top width of 2 feet. A rock berm shall be placed at locations of the concentrated flows where the drainage area is between 2 and 5 acres.
4. Inlet Protection – Placed around inlets to catch and stop sediment from entering the storm drain system before filtration system are in place.
5. Concrete Washout Pit – Designed to trap and store waste from concrete and similar activities. This allows for safe storage and removal from the site by not allowing contaminants to enter the storm water. Contaminants can be kept in a location that will not allow storm water to mix and flow off the site.

### ***Sequence of installation during construction process***

1. The Temporary Construction Entrance/Exit (Item 1) shall be installed prior to disturbing any soil except at the location of the Temporary Construction Entrance/Exit. It shall stay in place and be maintained until the end of the infrastructure construction.
2. Silt fence (Item 2) shall be installed along the western boundary of the site prior to any disturbance of the site
3. Rock berms (Item 4) shall be installed around the perimeter of the project at natural low points following rough grading of the site and shall be removed once grading to the on-site stormwater drainage system with bagged gravel inlet filters in sump is complete. Rock berms will also be utilized at the outlet of the pond while it is being constructed.

The TBMPs and measures utilized for the proposed project to prevent pollution of storm water, groundwater, and surface water during the construction phase are the following:

1. Temporary Construction Entrance/Exit
2. Silt Fence
3. Concrete Washout Pit
4. Rock Berm
5. Inlet Protection



## **Attachment D – Temporary Best Management Practices and Measures**

Stormwater originating from upgradient.

- Stormwater originating from upgradient from the east site of the property will be routed around the site by proposed grading.

Stormwater originating from onsite.

- Stormwater originating from onsite will be maintained by the proposed TMBPs (Silt fence, rock berms, etc.) to stay within the project limits and treated by the proposed PBMP.

Prevent stormwater from entering surface water, sensitive features and aquifer.

- No stormwater is expected to enter any surface water, sensitive feature or directly to the aquifer.

Will maintain flow to naturally occurring sensitive features.

- No naturally occurring sensitive features are documented on the geological assessment table.

### 1.4.2 Temporary Construction Entrance/Exit

The purpose of a temporary gravel construction entrance is to provide a stable entrance/exit condition from the construction site and keep mud and sediment off public roads. A stabilized construction entrance is a stabilized pad of crushed stone located at any point traffic will be entering or leaving the construction site from a public right-of-way, street, alley, sidewalk or parking area. The purpose of a stabilized construction entrance is to reduce or eliminate the tracking or flowing of sediment onto public rights-of-way. This practice should be used at all points of construction ingress and egress. Schematic diagrams of a construction entrance/exit are shown in Figure 1-24 and Figure 1-25.

Excessive amounts of mud can also present a safety hazard to roadway users. To minimize the amount of sediment loss to nearby roads, access to the construction site should be limited to as few points as possible and vegetation around the perimeter should be protected where access is not necessary. A rock stabilized construction entrance should be used at all designated access points.

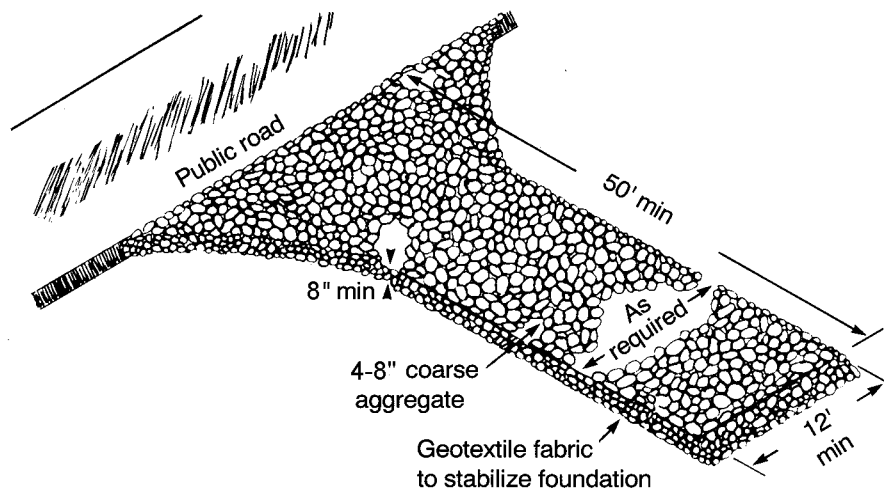

Figure 1-24 Schematic of Temporary Construction Entrance/Exit (after NC, 1993)

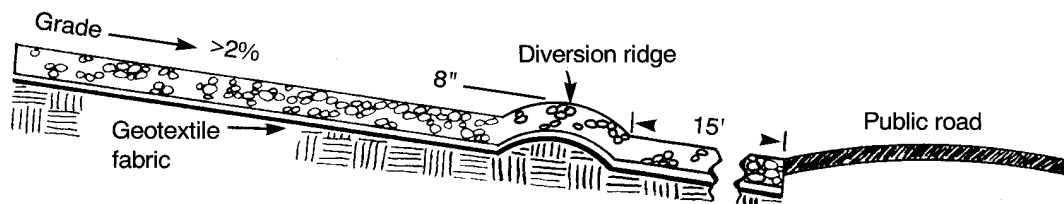

Figure 1-25 Cross-section of a Construction Entrance/Exit (NC, 1993)

**Materials:**

- (1) The aggregate should consist of 4 to 8 inch washed stone over a stable foundation as specified in the plan.
- (2) The aggregate should be placed with a minimum thickness of 8 inches.
- (3) The geotextile fabric should be designed specifically for use as a soil filtration media with an approximate weight of 6 oz/yd<sup>2</sup>, a mullen burst rating of 140 lb/in<sup>2</sup>, and an equivalent opening size greater than a number 50 sieve.
- (4) If a washing facility is required, a level area with a minimum of 4 inch diameter washed stone or commercial rack should be included in the plans. Divert wastewater to a sediment trap or basin.

**Installation:** (North Carolina, 1993)

- (1) Avoid curves on public roads and steep slopes. Remove vegetation and other objectionable material from the foundation area. Grade crown foundation for positive drainage.
- (2) The minimum width of the entrance/exit should be 12 feet or the full width of exit roadway, whichever is greater.
- (3) The construction entrance should be at least 50 feet long.
- (4) If the slope toward the road exceeds 2%, construct a ridge, 6 to 8 inches high with 3:1 (H:V) side slopes, across the foundation approximately 15 feet from the entrance to divert runoff away from the public road.
- (5) Place geotextile fabric and grade foundation to improve stability, especially where wet conditions are anticipated.
- (6) Place stone to dimensions and grade shown on plans. Leave surface smooth and slope for drainage.
- (7) Divert all surface runoff and drainage from the stone pad to a sediment trap or basin.
- (8) Install pipe under pad as needed to maintain proper public road drainage.

### **Common trouble points**

- (1) Inadequate runoff control – sediment washes onto public road.
- (2) Stone too small or geotextile fabric absent, results in muddy condition as stone is pressed into soil.
- (3) Pad too short for heavy construction traffic – extend pad beyond the minimum 50 foot length as necessary.
- (4) Pad not flared sufficiently at road surface, results in mud being tracked on to road and possible damage to road edge.
- (5) Unstable foundation – use geotextile fabric under pad and/or improve foundation drainage.

### **Inspection and Maintenance Guidelines:**

- (1) The entrance should be maintained in a condition, which will prevent tracking or flowing of sediment onto public rights-of-way. This may require periodic top dressing with additional stone as conditions demand and repair and/or cleanout of any measures used to trap sediment.
- (2) All sediment spilled, dropped, washed or tracked onto public rights-of-way should be removed immediately by contractor.
- (3) When necessary, wheels should be cleaned to remove sediment prior to entrance onto public right-of-way.
- (4) When washing is required, it should be done on an area stabilized with crushed stone that drains into an approved sediment trap or sediment basin.
- (5) All sediment should be prevented from entering any storm drain, ditch or water course by using approved methods.

### 1.4.3 Silt Fence

A silt fence is a barrier consisting of geotextile fabric supported by metal posts to prevent soil and sediment loss from a site. When properly used, silt fences can be highly effective at controlling sediment from disturbed areas. They cause runoff to pond, allowing heavier solids to settle out. If not properly installed, silt fences are not likely to be effective. A schematic illustration of a silt fence is shown in Figure 1-26.

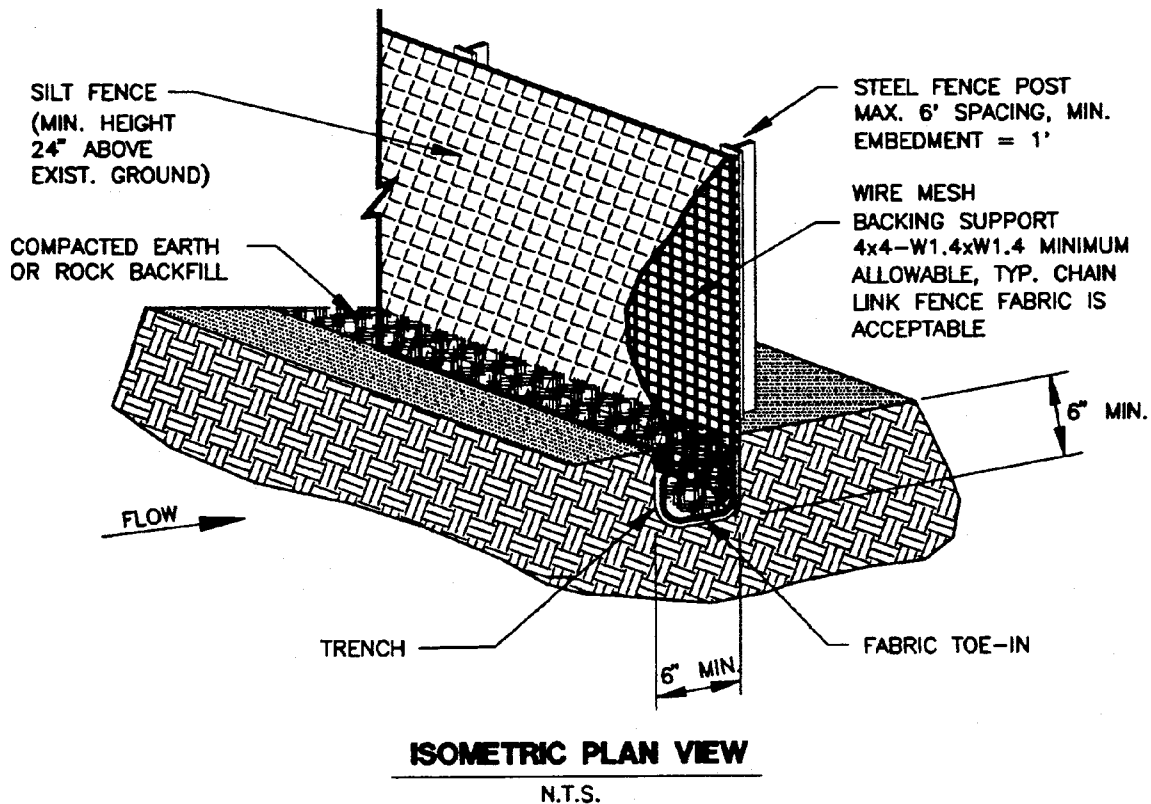

**Figure 1-26 Schematic of a Silt Fence Installation (NCTCOG, 1993b)**

The purpose of a silt fence is to intercept and detain water-borne sediment from unprotected areas of a limited extent. Silt fence is used during the period of construction near the perimeter of a disturbed area to intercept sediment while allowing water to percolate through. This fence should remain in place until the disturbed area is permanently stabilized. Silt fence should not be used where there is a concentration of water in a channel or drainage way. If concentrated flow occurs after installation, corrective action must be taken such as placing a rock berm in the areas of concentrated flow.

Silt fencing within the site may be temporarily moved during the day to allow construction activity provided it is replaced and properly anchored to the ground at the end of the day. Silt fences on the perimeter of the site or around drainage ways should not be moved at any time.

**Materials:**

- (1) Silt fence material should be polypropylene, polyethylene or polyamide woven or nonwoven fabric. The fabric width should be 36 inches, with a minimum unit weight of 4.5 oz/yd, mullen burst strength exceeding 190 lb/in<sup>2</sup>, ultraviolet stability exceeding 70%, and minimum apparent opening size of U.S. Sieve No. 30.
- (2) Fence posts should be made of hot rolled steel, at least 4 feet long with Tee or Y-bar cross section, surface painted or galvanized, minimum nominal weight 1.25 lb/ft<sup>2</sup>, and Brindell hardness exceeding 140.
- (3) Woven wire backing to support the fabric should be galvanized 2" x 4" welded wire, 12 gauge minimum.

**Installation:**

- (1) Steel posts, which support the silt fence, should be installed on a slight angle toward the anticipated runoff source. Post must be embedded a minimum of 1-foot deep and spaced not more than 8 feet on center. Where water concentrates, the maximum spacing should be 6 feet.
- (2) Lay out fencing down-slope of disturbed area, following the contour as closely as possible. The fence should be sited so that the maximum drainage area is ¼ acre/100 feet of fence.
- (3) The toe of the silt fence should be trenched in with a spade or mechanical trencher, so that the down-slope face of the trench is flat and perpendicular to the line of flow. Where fence cannot be trenched in (e.g., pavement or rock outcrop), weight fabric flap with 3 inches of pea gravel on uphill side to prevent flow from seeping under fence.
- (4) The trench must be a minimum of 6 inches deep and 6 inches wide to allow for the silt fence fabric to be laid in the ground and backfilled with compacted material.
- (5) Silt fence should be securely fastened to each steel support post or to woven wire, which is in turn attached to the steel fence post. There should be a 3-foot overlap, securely fastened where ends of fabric meet.

- (6) Silt fence should be removed when the site is completely stabilized so as not to block or impede storm flow or drainage.

**Common Trouble Points:**

- (1) Fence not installed along the contour causing water to concentrate and flow over the fence.
- (2) Fabric not seated securely to ground (runoff passing under fence)
- (3) Fence not installed perpendicular to flow line (runoff escaping around sides)
- (4) Fence treating too large an area, or excessive channel flow (runoff overtops or collapses fence)

**Inspection and Maintenance Guidelines:**

- (1) Inspect all fencing weekly, and after any rainfall.
- (2) Remove sediment when buildup reaches 6 inches.
- (3) Replace any torn fabric or install a second line of fencing parallel to the torn section.
- (4) Replace or repair any sections crushed or collapsed in the course of construction activity. If a section of fence is obstructing vehicular access, consider relocating it to a spot where it will provide equal protection, but will not obstruct vehicles. A triangular filter dike may be preferable to a silt fence at common vehicle access points.
- (5) When construction is complete, the sediment should be disposed of in a manner that will not cause additional siltation and the prior location of the silt fence should be revegetated. The fence itself should be disposed of in an approved landfill.

#### 1.4.5 Rock Berms

The purpose of a rock berm is to serve as a check dam in areas of concentrated flow, to intercept sediment-laden runoff, detain the sediment and release the water in sheet flow. The rock berm should be used when the contributing drainage area is less than 5 acres. Rock berms are used in areas where the volume of runoff is too great for a silt fence to contain. They are less effective for sediment removal than silt fences, particularly for fine particles, but are able to withstand higher flows than a silt fence. As such, rock berms are often used in areas of channel flows (ditches, gullies, etc.). Rock berms are most effective at reducing bed load in channels and should not be substituted for other erosion and sediment control measures farther up the watershed.

##### **Materials:**

- (1) The berm structure should be secured with a woven wire sheathing having maximum opening of 1 inch and a minimum wire diameter of 20 gauge galvanized and should be secured with shoat rings.
- (2) Clean, open graded 3- to 5-inch diameter rock should be used, except in areas where high velocities or large volumes of flow are expected, where 5- to 8-inch diameter rocks may be used.

##### **Installation:**

- (1) Lay out the woven wire sheathing perpendicular to the flow line. The sheathing should be 20 gauge woven wire mesh with 1 inch openings.
- (2) Berm should have a top width of 2 feet minimum with side slopes being 2:1 (H:V) or flatter.
- (3) Place the rock along the sheathing as shown in the diagram (Figure 1-28), to a height not less than 18".
- (4) Wrap the wire sheathing around the rock and secure with tie wire so that the ends of the sheathing overlap at least 2 inches, and the berm retains its shape when walked upon.
- (5) Berm should be built along the contour at zero percent grade or as near as possible.
- (6) The ends of the berm should be tied into existing upslope grade and the berm should be buried in a trench approximately 3 to 4 inches deep to prevent failure of the control.



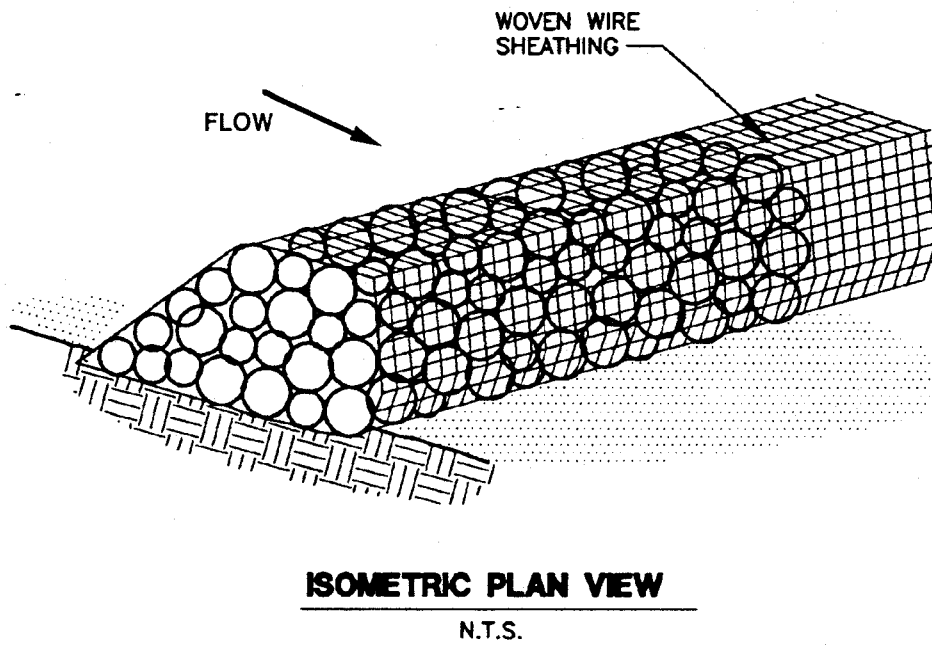
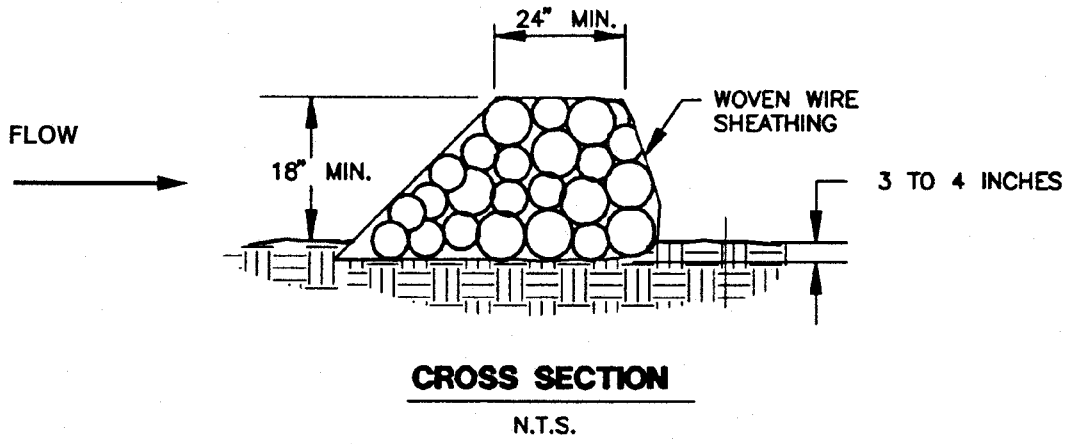

Figure 1-28 Schematic Diagram of a Rock Berm (NCTCOG, 1993)

**Common Trouble Points:**

- (1) Insufficient berm height or length (runoff quickly escapes over the top or around the sides of berm)
- (2) Berm not installed perpendicular to flow line (runoff escaping around one side)

**Inspection and Maintenance Guidelines:**

- (1) Inspection should be made weekly and after each rainfall by the responsible party. For installations in streambeds, additional daily inspections should be made.
- (2) Remove sediment and other debris when buildup reaches 6 inches and dispose of the accumulated silt in an approved manner that will not cause any additional siltation.
- (3) Repair any loose wire sheathing.
- (4) The berm should be reshaped as needed during inspection.
- (5) The berm should be replaced when the structure ceases to function as intended due to silt accumulation among the rocks, washout, construction traffic damage, etc.
- (6) The rock berm should be left in place until all upstream areas are stabilized and accumulated silt removed.

#### 1.4.18 Concrete Washout Areas

The purpose of concrete washout areas is to prevent or reduce the discharge of pollutants to stormwater from concrete waste by conducting washout offsite, performing onsite washout in a designated area, and training employees and subcontractors.

The following steps will help reduce stormwater pollution from concrete wastes:

- Incorporate requirements for concrete waste management into material supplier and subcontractor agreements.
- Avoid mixing excess amounts of fresh concrete.
- Perform washout of concrete trucks in designated areas only.
- Do not wash out concrete trucks into storm drains, open ditches, streets, or streams.
- Do not allow excess concrete to be dumped onsite, except in designated areas.

For onsite washout:

- Locate washout area at least 50 feet from sensitive features, storm drains, open ditches, or water bodies. Do not allow runoff from this area by constructing a temporary pit or bermed area large enough for liquid and solid waste.
- Wash out wastes into the temporary pit where the concrete can set, be broken up, and then disposed properly.

Below grade concrete washout facilities are typical. These consist of a lined excavation sufficiently large to hold expected volume of washout material. Above grade facilities are used if excavation is not practical. Temporary concrete washout facility (type above grade) should be constructed as shown on the details at the end of this section, with sufficient quantity and volume to contain all liquid and concrete waste generated by washout operations. Plastic lining material should be a minimum of 10 mil in polyethylene sheeting and should be free of holes, tears, or other defects that compromise the impermeability of the material.

When temporary concrete washout facilities are no longer required for the work, the hardened concrete should be removed and disposed of. Materials used to construct temporary concrete washout facilities should be removed from the site of the work and disposed of. Holes, depressions or other ground disturbance caused by the removal of the temporary concrete washout facilities should be backfilled and repaired.

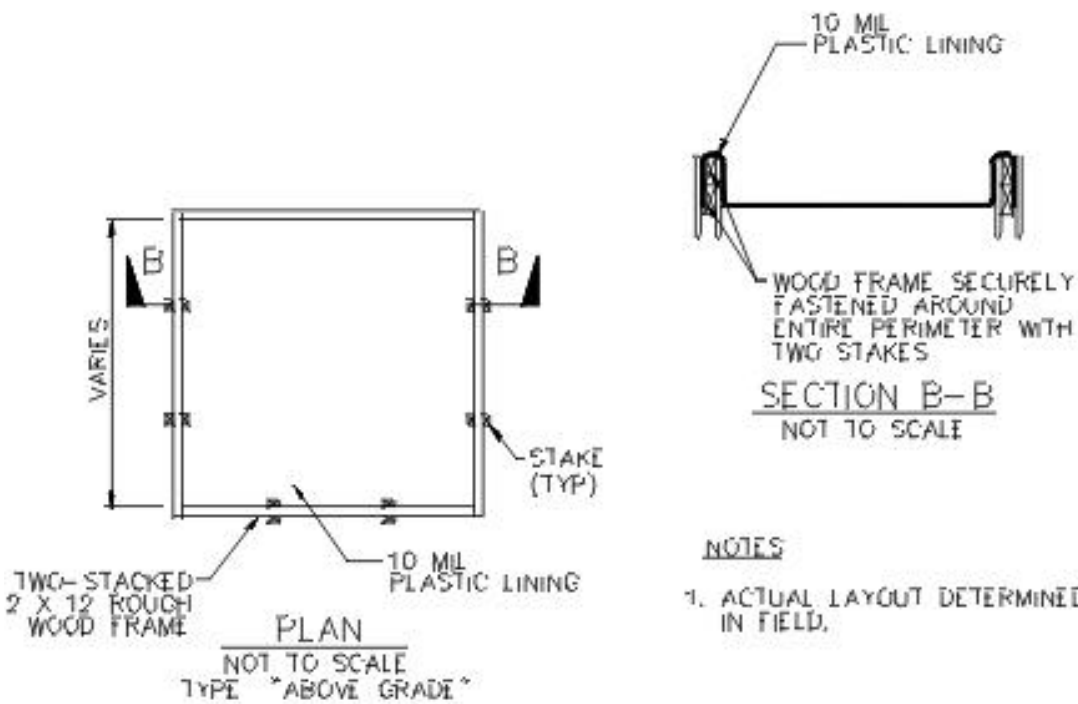
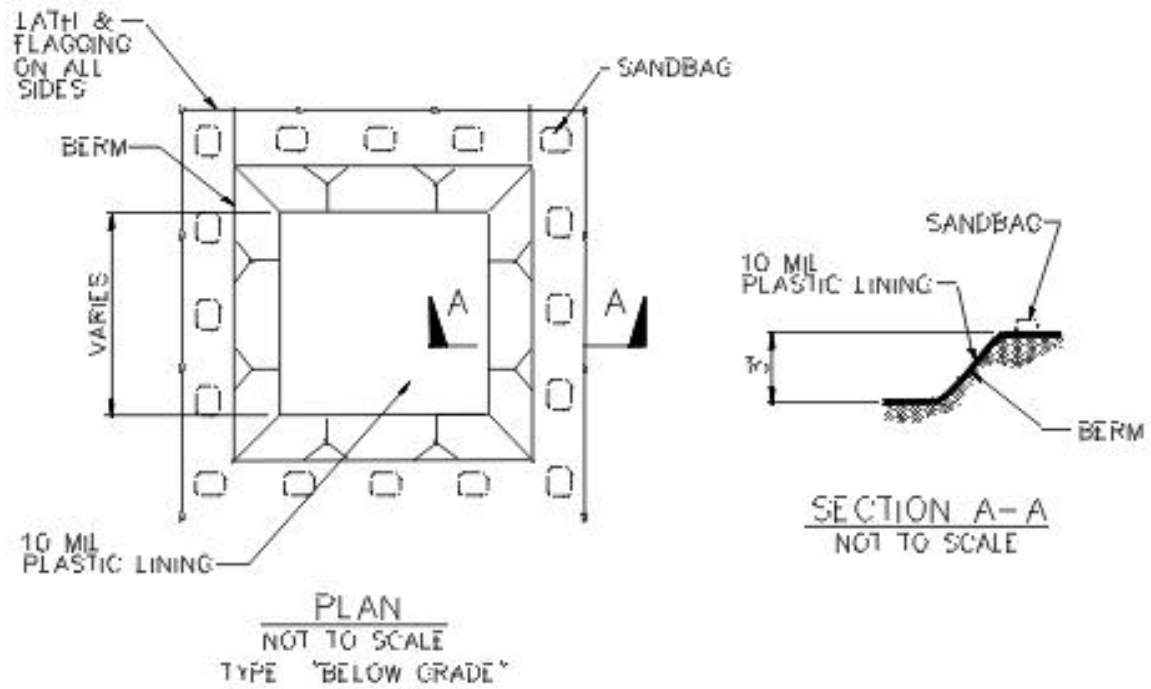

Figure 1-43 Schematics of Concrete Washout Areas

#### 1.4.11 Inlet Protection

Storm sewers that are made operational prior to stabilization of the associated drainage areas can convey large amounts of sediment to natural drainage ways. In case of extreme sediment loading, the storm sewer itself may clog and lose a major portion of its capacity. To avoid these problems, it is necessary to prevent sediment from entering the system at the inlets. The following guidelines for inlet protection are based primarily on recommendations by the Virginia Dept. of Conservation and Recreation (1992) and the North Central Texas Council of Governments (NCTCOG, 1993b).

In developments for which drainage is to be conveyed by underground storm sewers (i.e., streets with curbs and gutters), all inlets that may receive storm runoff from disturbed areas should be protected. Temporary inlet protection is a series of different measures that provide protection against silt transport or accumulation in storm sewer systems. This clogging can greatly reduce or completely stop the flow in the pipes. The different measures are used for different site conditions and inlet types.

Care should be taken when choosing a specific type of inlet protection. Field experience has shown that inlet protection that causes excessive ponding in an area of high construction activity may become so inconvenient that it is removed or bypassed, thus transmitting sediment-laden flows unchecked. In such situations, a structure with an adequate overflow mechanism should be utilized.

It should also be noted that inlet protection devices are designed to be installed on construction sites and not on streets and roads open to the public. When used on public streets these devices will cause ponding of runoff, which can cause minor flooding and can present a traffic hazard. An example of appropriate siting would be a new subdivision where the storm drain system is installed before the area is stabilized and the streets open to the general public. When construction occurs adjacent to active streets, the sediment should be controlled on site and not on public thoroughfares. Occasionally, roadwork or utility installation will occur on public roads. In these cases, inlet protection is an appropriate temporary BMP.

The following inlet protection devices are for drainage areas of one acre or less. Runoff from larger disturbed areas should be routed to a temporary sediment trap or basin.

Filter barrier protection using silt fence is appropriate when the drainage area is less than one acre and the basin slope is less than five percent. This type of protection is not applicable in paved areas.

Block and gravel protection is used when flows exceed 0.5 cubic feet per second and it is necessary to allow for overtopping to prevent flooding. This form of protection is also useful for curb type inlets as it works well in paved areas.

Wire mesh and gravel protection is used when flows exceed 0.5 cubic feet per second and construction traffic may occur over the inlet. This form of protection may be used with both curb and drop inlets.

Excavated impoundment protection around a drop inlet may be used for protection against sediment entering a storm drain inlet. With this method, it is necessary to install weep holes to allow the impoundment to drain completely. If this measure is implemented, the impoundment should be sized such that the volume of excavation is 3,600 cubic feet per acre (equivalent to 1 inch of runoff) of disturbed area entering the inlet.

**Materials:**

- (1) Filter fabric should be a nylon reinforced polypropylene fabric which meets the following minimum criteria: Tensile Strength, 90 lbs.; Puncture Rating, 60 lbs.; Mullen Burst Rating, 280 psi; Apparent Opening Size, U.S. Sieve No. 70.
- (2) Posts for fabric should be 2" x 4" pressure treated wood stakes or galvanized steel, tubular in cross-section or they may be standard fence "T" posts.
- (3) Concrete blocks should be standard 8" x 8" x 16" concrete masonry units.
- (4) Wire mesh should be standard hardware cloth or comparable wire mesh with an opening size not to exceed 1/2 inch.

**Guidelines for installation:**

*Silt Fence Drop Inlet Protection*

- (1) Silt fence should conform to the specifications listed above and should be cut from a continuous roll to avoid joints.
- (2) For stakes, use 2 x 4-inch wood or equivalent metal with a minimum length of 3 feet.
- (3) Space stakes evenly around the perimeter of the inlet a maximum of 3 feet apart, and securely drive them into the ground, approximately 18 inches deep (Figure 1-33).
- (4) To provide needed stability to the installation, a frame with 2 x 4-inch wood strips around the crest of the overflow area at a maximum of 1½ feet above the drop inlet crest should be provided.

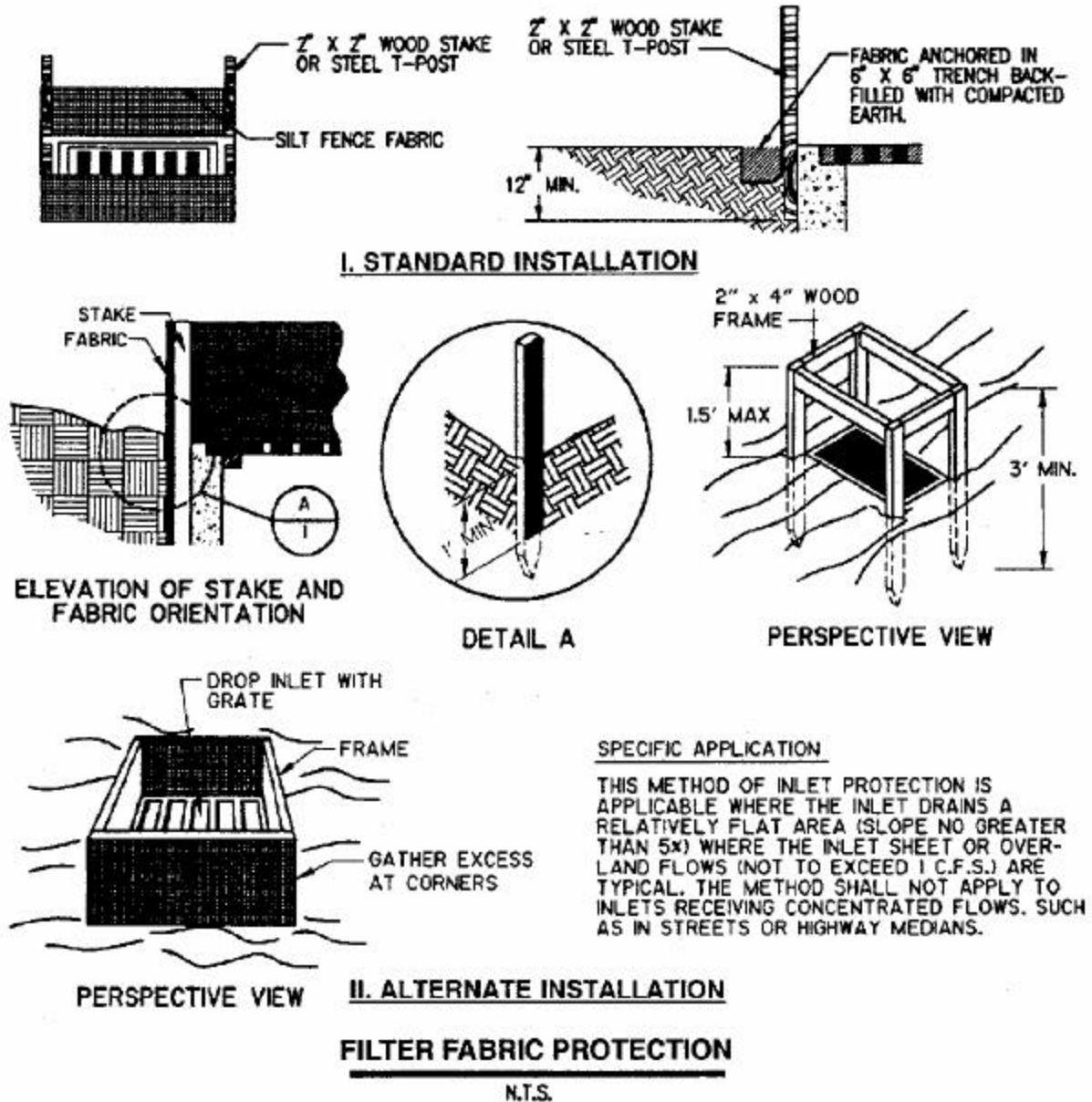

**Figure 1-33 Filter Fabric Inlet Protection (NCTCOG, 1993)**

- (5) Place the bottom 12 inches of the fabric in a trench and backfill the trench with 12 inches of compacted soil.
- (6) Fasten fabric securely by staples or wire to the stakes and frame. Joints must be overlapped to the next stake.
- (7) It may be necessary to build a temporary dike on the down slope side of the structure to prevent bypass flow.

If the drop inlet is above the finished grade, the grate may be completely covered with filter fabric. The fabric should be securely attached to the entire perimeter of the inlet using 1"x 2" wood strips and appropriate fasteners.

### *Gravel and Wire Mesh Drop Inlet Sediment Filter*

- (1) Wire mesh should be laid over the drop inlet so that the wire extends a minimum of 1 foot beyond each side of the inlet structure. Wire mesh with 1/2-inch openings should be used. If more than one strip of mesh is necessary, the strips should be overlapped (see Figure 1-34).

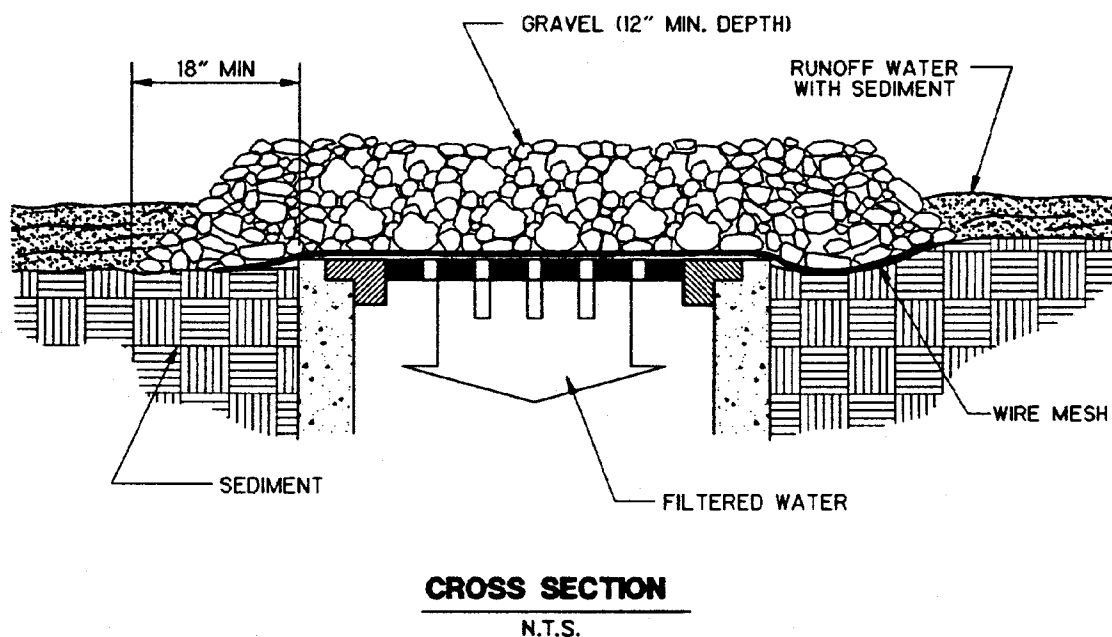

**Figure 1-34 Wire Mesh and Gravel Inlet Protection (NCTCOG, 1993)**

- (2) Coarse aggregate should be placed over the wire mesh as indicated in Figure 1-34. The depth of stone should be at least 12 inches over the entire inlet opening. The stone should extend beyond the inlet opening at least 18 inches on all sides.
- (3) If the stone filter becomes clogged with sediment so that it no longer adequately performs its function, the stones must be pulled away from the inlet, cleaned and/or replaced.

Note: This filtering device has no overflow mechanism; therefore, ponding is likely especially if sediment is not removed regularly. This type of device should never be used where overflow may endanger an exposed fill slope. Consideration should also be given to the possible effects of ponding on traffic movement, nearby structures, working areas, adjacent property, etc.



### *Block and Gravel Drop Inlet Sediment Filter*

- (1) Place concrete blocks lengthwise on their sides in a single row around the perimeter of the inlet, with the ends of adjacent blocks abutting. The height of the barrier can be varied, depending on design needs, by stacking combinations of 4-inch, 8-inch and 12-inch wide blocks. The barrier of blocks should be between 12 and 24 inches high.
- (2) Wire mesh should be placed over the outside vertical face (webbing) of the concrete blocks to prevent stone from being washed through the holes in the blocks. Wire mesh with 1/2-inch openings should be used.
- (3) Stone should be piled against the wire to the top of the block barrier, as shown in Figure 1-35.
- (4) If the stone filter becomes clogged with sediment so that it no longer adequately performs its function, the stone must be pulled away from the blocks, cleaned and replaced.

### *Block and Gravel Curb Inlet Sediment Filter*

- (1) Two concrete blocks should be placed on their sides abutting the curb at either side of the inlet opening.
- (2) A 2-inch x 4-inch stud should be cut and placed through the outer holes of each spacer block to help keep the front blocks in place.
- (3) Concrete blocks should be placed on their sides across the front of the inlet and abutting the spacer blocks as depicted in Figure 1-35.
- (4) Wire mesh should be placed over the outside vertical face (webbing) of the concrete blocks to prevent stone from being washed through the holes in the blocks. Wire mesh with 1/2-inch openings should be used.
- (5) Coarse aggregate should be piled against the wire to the top of the barrier as shown in Figure 1-35.
- (6) If the stone filter becomes clogged with sediment so that it no longer adequately performs its function, the stone must be pulled away from the blocks, cleaned and/or replaced.

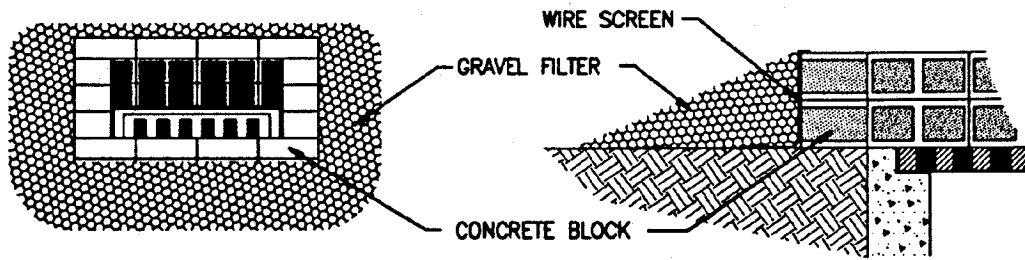

**DROP INLET PROTECTION**

N.T.S.

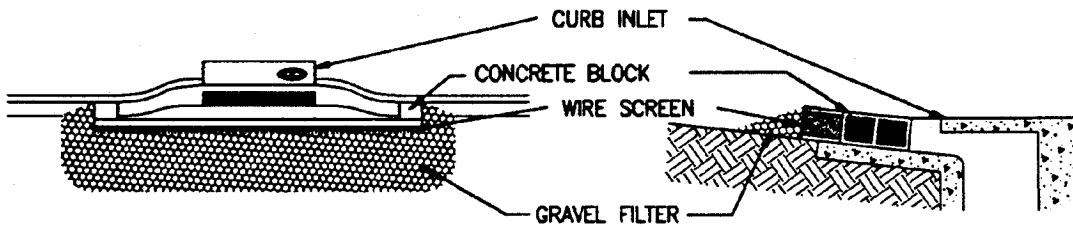

**CURB INLET PROTECTION**

N.T.S.

**Figure 1-35 Block and Gravel Inlet Protection (NCTCOG, 1993)**

*Excavated Drop Inlet Sediment Trap*

- (1) The excavated trap should be sized to provide a minimum storage capacity calculated at 3,600 cubic feet per acre of drainage area. A trap should be no less than 1-foot nor more than 2 feet deep measured from the top of the inlet structure. Side slopes should not be steeper than 2:1 (see Figure 1-36).

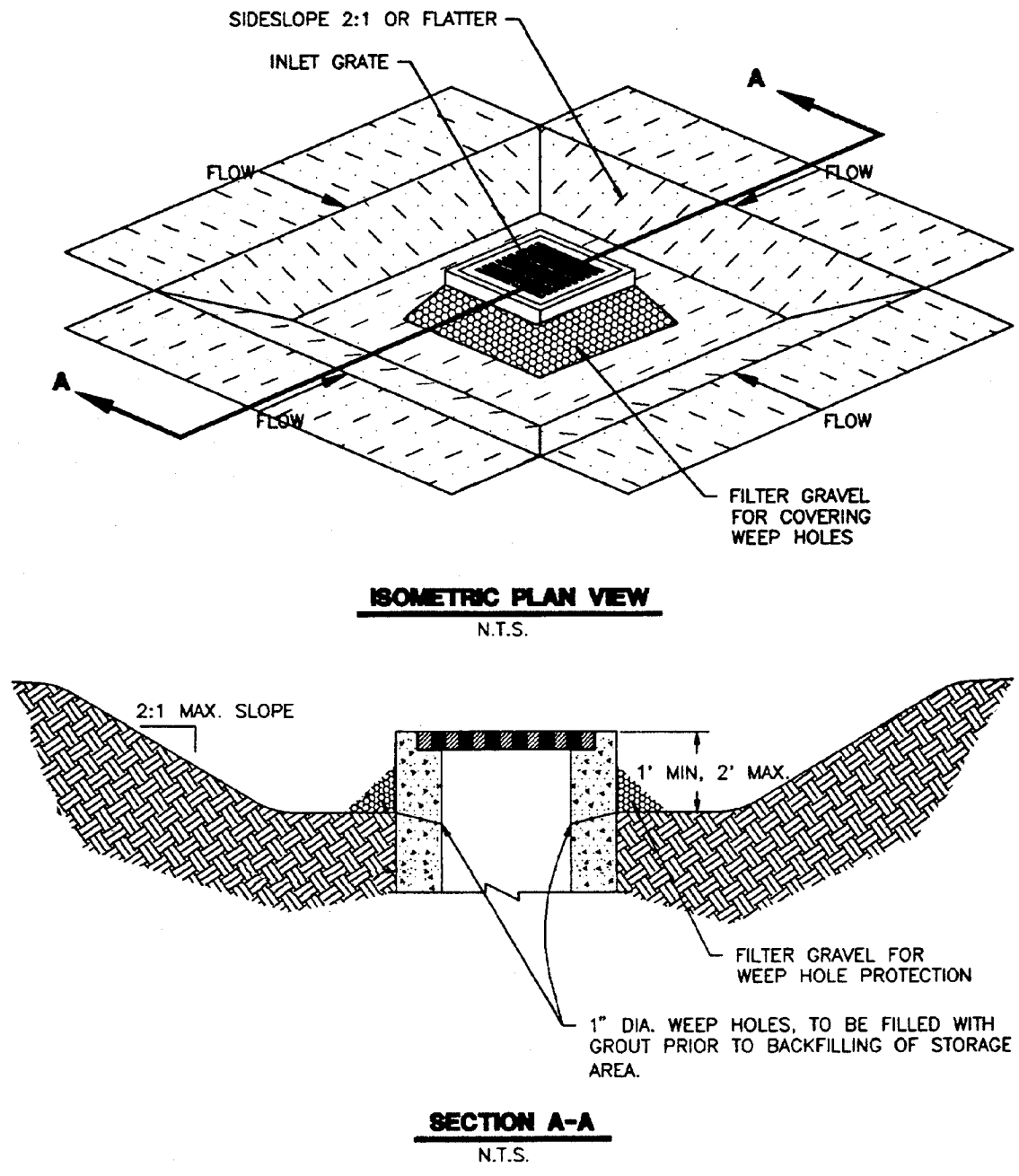

**Figure 1-36 Excavated Inlet Protection (NCTCOG, 1993)**

- (2) The slope of the basin may vary to fit the drainage area and terrain. Observations must be made to check trap efficiency and modifications should be made as necessary to ensure satisfactory trapping of sediment. Where an inlet is located so as to receive concentrated flows, such as in a highway median, it is recommended that the basin have a rectangular shape in a 2:1 (length/width) ratio, with the length oriented in the direction of the flow.

- (3) Sediment should be removed and the trap restored to its original dimensions when the sediment has accumulated to one-half the design depth of the trap. Removed sediment should be deposited in a suitable area and in a manner such that it will not erode.

*Curb Inlet Protection with 2-inch x 4-inch Wooden Weir*

- (1) Attach a continuous piece of wire mesh (30-inch minimum width x inlet throat length plus 4 feet) to the 2-inch x 4-inch wooden weir (with a total length of throat length plus 2 feet) as shown in Figure 1-37. Wood should be “construction grade” lumber.
- (2) Place a piece of approved filter cloth of the same dimensions as the wire mesh over the wire mesh and securely attach to the 2-inch x 4-inch weir.
- (3) Securely nail the 2-inch x 4-inch weir to the 9-inch long vertical spacers which are to be located between the weir and inlet face at a maximum 6-foot spacing.
- (4) Place the assembly against the inlet throat and nail 2-foot (minimum) lengths of 2-inch x 4-inch board to the top of the weir at spacer locations. These 2-inch x 4-inch anchors should extend across the inlet tops and be held in place by sandbags or alternate weight.
- (5) The assembly should be placed so that the end spacers are a minimum 1 foot beyond both ends of the throat opening.
- (6) Form the wire mesh and filter cloth to the concrete gutter and against the face of curb on both sides of the inlet. Place coarse aggregate over the wire mesh and filter fabric in such a manner as to prevent water from entering the inlet under or around the filter cloth.
- (7) This type of protection should be inspected frequently and the filter cloth and stone replaced when clogged with sediment.
- (8) Assure that storm flow does not bypass inlet by installing temporary earth or asphalt dikes directing flow into inlet.

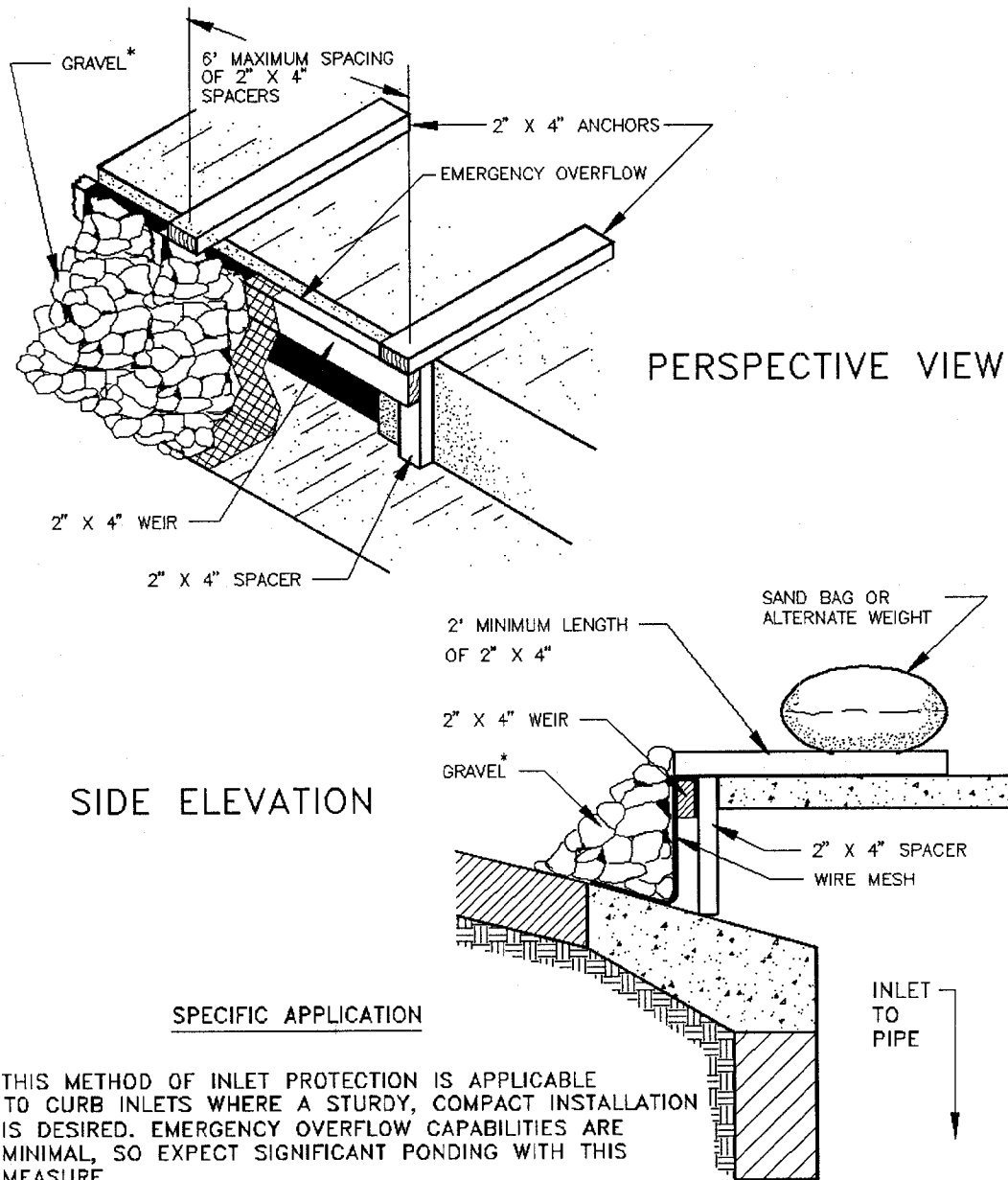

**Figure 1-37 Wooden Weir Curb Inlet Protection (VA Dept of Conservation, 1992)**

**Common Trouble Points:**

- (1) Gaps between the inlet protection and the curb (flows bypass around side of filter).
- (2) Filter fabric skirt not anchored to pavement (flows pass under filter).

### *Bagged Gravel Inlet Filter*

Sandbags filled with pea gravel can also be used to construct a sediment barrier around curb and drain inlets. The sandbags should be filled with washed pea gravel and stacked to form a continuous barrier about 1 foot high around the inlets. The bags should be tightly abutted against each other to prevent runoff from flowing between the bags. This measure should be installed as shown in Figure 1-38.

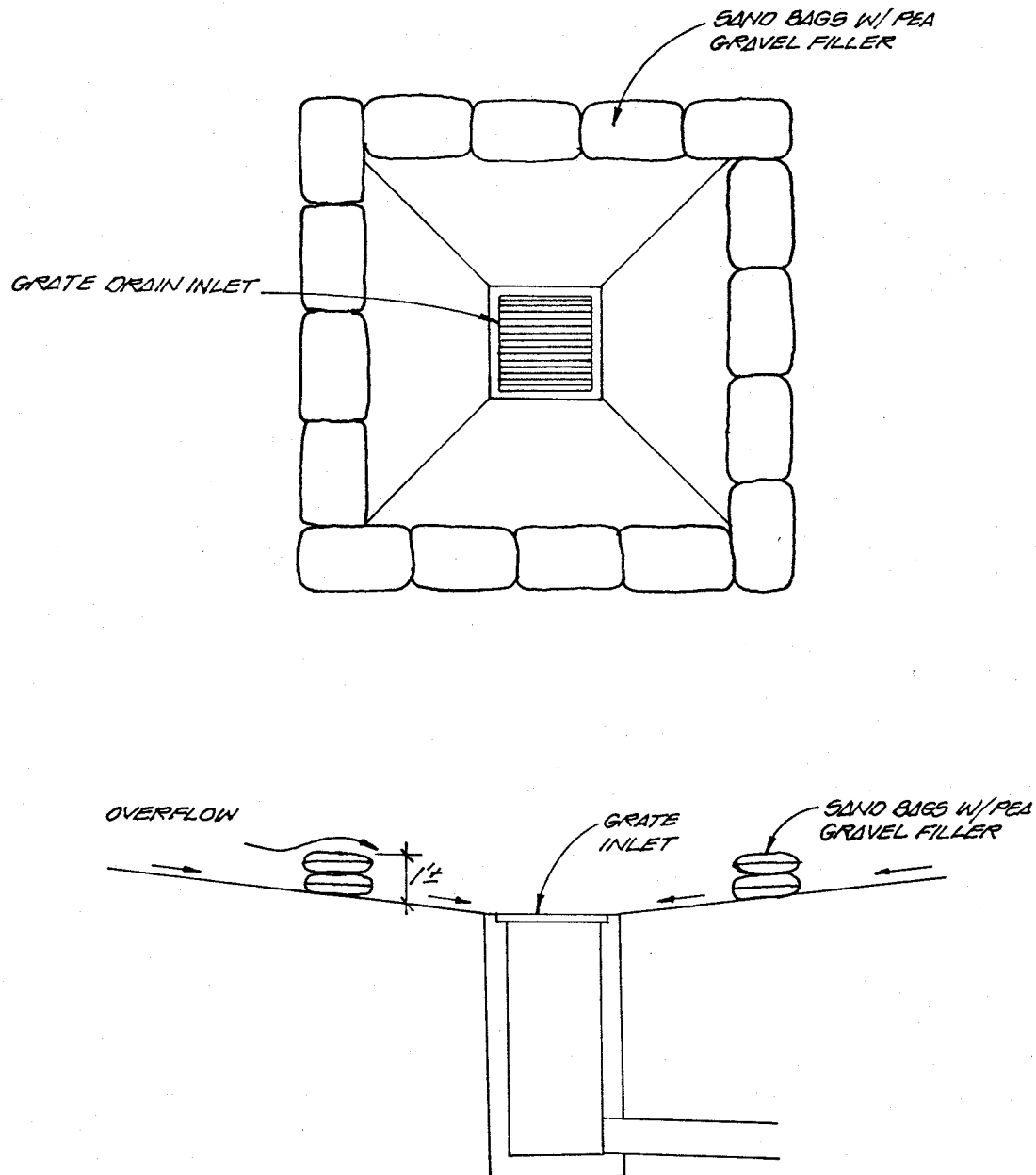

**Figure 1-38 Diagram of Bagged Gravel Grate Inlet Protection (Pape-Dawson)**

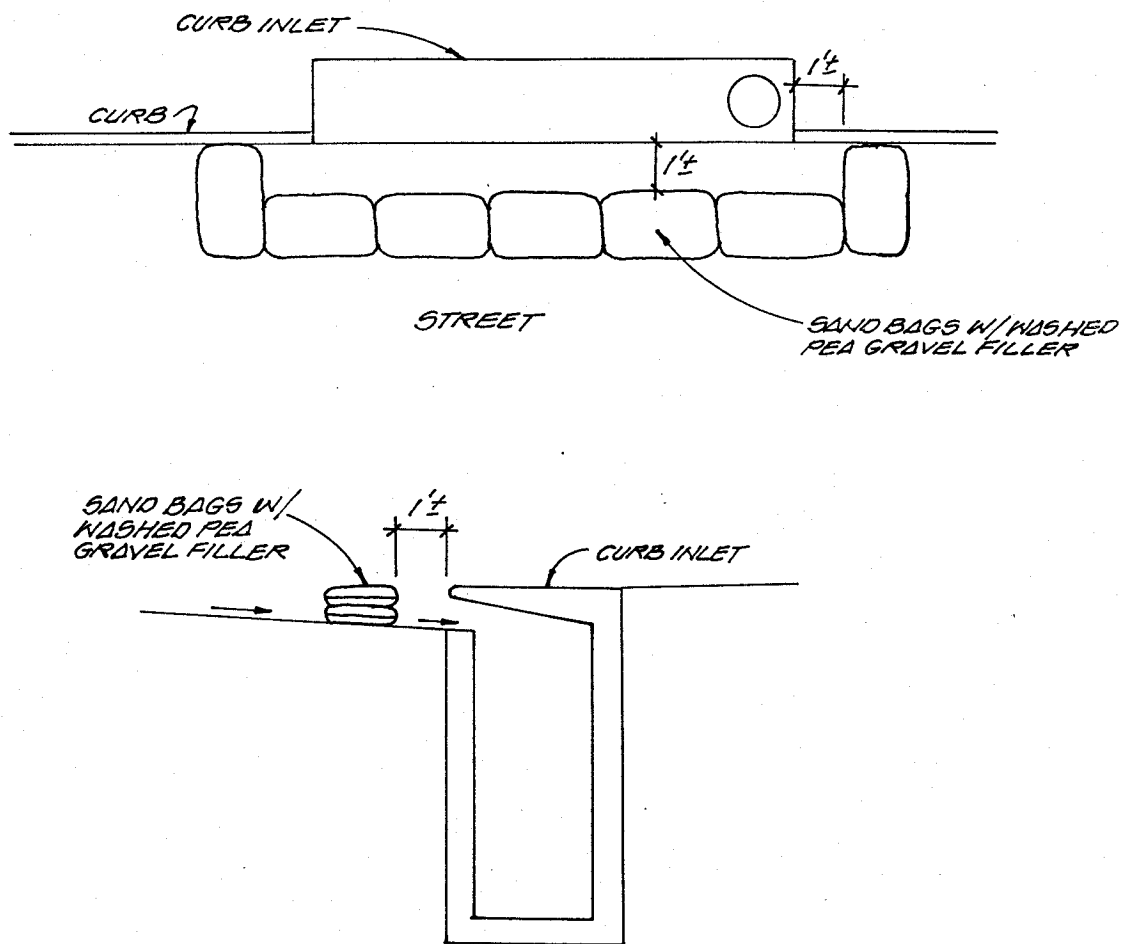

**Figure 1-39 Diagram of Bagged Gravel Curb Inlet Protection (Pape-Dawson).**

**Inspection and Maintenance Guidelines:**

- (1) Inspection should be made weekly and after each rainfall. Repair or replacement should be made promptly as needed by the contractor.
- (2) Remove sediment when buildup reaches a depth of 3 inches. Removed sediment should be deposited in a suitable area and in such a manner that it will not erode.
- (3) Check placement of device to prevent gaps between device and curb.
- (4) Inspect filter fabric and patch or replace if torn or missing.

- (5) Structures should be removed and the area stabilized only after the remaining drainage area has been properly stabilized.



### **Attachment E – Request to Temporarily Seal a Feature**

No sensitive features will be sealed in this project site.

### **Attachment F – Structural Practices**

The following structural measures will be installed prior to the initiation of site preparation activities:

- Erection of silt fences along the downgradient boundary of construction activities and rock berms with silt fence for secondary protection, as located on WPAP SITE PLAN
- Installation of stabilized construction entrance/exit(s) and construction staging area(s), as located on WPAP SITE PLAN

The following structural measures will be installed at the initiation of construction activities or as appropriate based on the construction sequencing:

- Installation of concrete truck washout pit(s), as required and located on WPAP SITE PLAN

### **Attachment G – Drainage Area Map**

See Sheet WPAP Drainage Area Map attached at the end of these attachments.

### **Attachment H – Temporary Sediment Pond(s) Plans and Calculations**

No Temporary Sediment Pond will be utilized with this project.

### **Attachment I – Inspection and Maintenance for TBMPs**

#### ***Inspections***

Designated and qualified person(s) shall inspect Pollution Control Measures weekly and within 24 hours after a storm event greater than 0.5 inches of rainfall. An inspection report that summarizes the scope of the inspection, names and qualifications of personnel conducting the inspection, date of the inspection, major observations, and actions taken as a result of the inspection shall be recorded and maintained as part of Storm Water TPDES data for a period of three years after the date of the inspection. A copy of the Inspection Report Form is provided in this Storm Water Pollution Prevention Plan.

As a minimum, the inspector shall observe: (1) significant disturbed areas for evidence of erosion, (2) storage areas for evidence of leakage from the exposed stored materials, (3) structural controls (rock berm outlets, silt fences, drainage swales, etc.) for evidence of failure or excess siltation (over 6 inches deep), (4) vehicle exit point for evidence of off-site sediment tracking, (5) vehicle storage areas for signs of leaking equipment or spills, and (6) concrete truck rinse-out pit for signs of potential failure. Deficiencies noted during the inspection will be corrected and documented within seven (7) calendar days following the inspection or before the next anticipated storm event if practicable.

Pollution Prevention Measure	Inspected	Corrective Action	
		Description	Date Completed
<b>General</b>			
Revegetation			
Erosion/Sediment Controls			
Vehicle Exits			
Material Areas			
Equipment Areas			
Concrete Rinse			
Construction Debris			
Trash Receptacles			
<b>Infrastructure</b>			
Roadway Clearing			
Utility Clearing			
Roadway Grading			
Utility Construction			
Drainage Construction			
Roadway Base			
Roadway Surfaces			
Site Cleanups			
<b>Building</b>			
Clearing for Building			
Foundation Grading			
Utility Construction			
Foundation Construction			
Building Construction			
Site Grading			
Site Cleanup			

*\*Indicate N/A where measure does not apply.*

By my signature below, I certify that all items are acceptable and the project site is in compliance with SWPPP.

\_\_\_\_\_  
Inspector's Name

\_\_\_\_\_  
Inspector's Signature

\_\_\_\_\_

\_\_\_\_\_

Name of Owner/Operator (Firm)

Date

***Note: Inspector is to attach a brief statement of his qualifications to this report.***

## PROJECT MILESTONE DATES

Date when major site grading activities begin:

<u>Construction Activity</u>	<u>Date</u>
_____	_____
_____	_____
_____	_____
_____	_____
_____	_____
_____	_____
_____	_____

Dates when construction activities temporarily or permanently cease on all or a portion of the project:

<u>Construction Activity</u>	<u>Date</u>
_____	_____
_____	_____
_____	_____
_____	_____
_____	_____
_____	_____
_____	_____

Date when stabilization measures are initiated:

<u>Stabilization Activity</u>	<u>Date</u>
_____	_____
_____	_____
_____	_____

## **Attachment I (con't) – Inspection and Maintenance for TBMPs**

### ***Temporary Sediment Control Fences***

1. Inspect all fencing weekly, and after any rainfall.
2. Remove sediment when buildup reaches 6 inches.
3. Replace any torn fabric or install a second line of fencing parallel to the torn section.
4. Replace or repair any sections crushed or collapsed in the course of construction activity. If a section of fence is obstructing vehicular access, consider relocating it to a spot where it will provide equal protection, but will not obstruct vehicles. A triangular filter dike may be preferable to a silt fence at common vehicle access points.
5. When construction is complete, the sediment should be disposed of in a manner that will not cause additional siltation and the prior location of silt fence should be revegetated. The fence itself should be disposed of in an approved landfill.

### ***Rock Berm/High Service Rock Berm***

1. Inspections should be made weekly and after each rainfall by the responsible party.
2. Remove sediment and other debris when buildup reaches 6 inches and dispose of the accumulated silt of in an approved manner.
3. Repair any loose wire sheathing.
4. The berm should be reshaped as needed during inspection.
5. The berm should be replaced when the structure ceases to function as intended due to silt accumulation among the rocks, washout, construction traffic damage, etc.
6. The rock berm should be left in place until all upstream areas are stabilized and accumulated silt removed.

### ***Temporary Construction Entrance and Exits***

1. The entrance should be maintained in a condition, which will prevent tracking or following of sediment onto public rights-of-way. This may require periodic top dressing with additional stone as conditions demand and repair and/or cleanout of any measures used to trap sediment.
2. All sediment spilled, dropped, washed or tracked on to public rights-of-ways should be removed immediately by contractor.
3. When necessary, wheels should be cleaned to remove sediment prior to entrance onto public right-of-way.
4. When washing is required, it should be done on an area stabilized with crushed stone that drains into an approved sediment trap or sediment basin.
5. All sediment should be prevented from entering ant storm drain, ditch, or water course by using approved methods.

### ***Bagged Gravel Inlet Filters***

1. Inspections should be made weekly and after each rainfall. Repair or replacement should be made promptly as needed by the contractor.
2. Remove sediment when buildup reached a depth of 3 inches. Removed sediment should be deposited in a suitable area and in such a manner that it will not erode.
3. Check placement of device to prevent gaps between device and curb.
4. Inspect filter fabric and patch or replace if torn or missing.
5. Structures should be removed and the area stabilized only after the remaining drainage area has been properly stabilized.

### ***Temporary Sedimentation Basin***

1. Inspection should be made weekly and after each rainfall. Check the embankment, spillways, and outlet for erosion damage, and inspect the embankment for piping and settlement. Repair should be made promptly as needed by contractor.
2. Trash and other debris should be removed after each rainfall to prevent clogging out of the outlet structure.
3. Accumulated silt should be removed and the basin should be re-graded to its original dimensions at such point that the capacity of the impoundment has been reduced to 75% of its original storage capacity.
4. The removed sediment should be stockpiled or redistributed in areas that are protected from erosion.

### ***Documentation Procedures***

1. A copy of the inspection report is located on the following page.
2. The inspection report must be maintained on site at all times.
3. The inspection report is incorporated as part of the WPAP. The contractor is responsible for completing and updating the form in compliance with TCEQ rules.

## **Attachment J – Schedule of Interim and Permanent Soil Stabilization**

Interim on-site stabilization measures, which are continuous, will include minimizing soil disturbances by exposing only the smallest practical area of land required for the shortest period of time and maximizing use of natural vegetation. As soon as practical, all disturbed soil will be stabilized as per project specifications in accordance with pages 1-35 to 1-60 of TCEQ's Technical Guidance Manual (TGM) RG-348 (2005). Mulching, netting, erosion blankets and seeding are acceptable.

Stabilization measures will be initiated as soon as practicable in portions of the site where construction activities have temporarily or permanently ceased, and except as provided below, will be initiated no more than fourteen (14) days after the construction activity in that portion of the site has temporarily or permanently ceased. Where construction activity on a portion of the site is temporarily ceased, and earth disturbing activities will be resumed within twenty-one (21) days, temporary stabilization measures do not have to be initiated on that portion of site. In areas experiencing droughts where

the initiation of stabilization measures by the 14th day after construction activity has temporarily or permanently ceased is precluded by seasonably arid conditions, stabilization measures must be initiated as soon as practicable.





**Agent Authorization Form**  
For Required Signature  
Edwards Aquifer Protection Program  
Relating to 30 TAC Chapter 213  
Effective June 1, 1999

I \_\_\_\_\_  
Garrett Mechler  
Print Name

\_\_\_\_\_  
Vice President  
Title - Owner/President/Other

of \_\_\_\_\_  
VERAMENDI PE-EMERALD LLC  
Corporation/Partnership/Entity Name

have authorized \_\_\_\_\_  
Priscilla Flores  
Print Name of Agent/Engineer

of \_\_\_\_\_  
LJA Engineering  
Print Name of Firm

to represent and act on the behalf of the above named Corporation, Partnership, or Entity for the purpose of preparing and submitting this plan application to the Texas Commission on Environmental Quality (TCEQ) for the review and approval consideration of regulated activities.

I also understand that:

1. The applicant is responsible for compliance with 30 Texas Administrative Code Chapter 213 and any condition of the TCEQ's approval letter. The TCEQ is authorized to assess administrative penalties of up to \$10,000 per day per violation.
2. For those submitting an application who are not the property owner, but who have the right to control and possess the property, additional authorization is required from the owner.
3. Application fees are due and payable at the time the application is submitted. The application fee must be sent to the TCEQ cashier or to the appropriate regional office. The application will not be considered until the correct fee is received by the commission.
4. A notarized copy of the Agent Authorization Form must be provided for the person preparing the application, and this form must accompany the completed application.
5. No person shall commence any regulated activity on the Edwards Aquifer Recharge Zone, Contributing Zone or Transition Zone until the appropriate application for the activity has been filed with and approved by the Executive Director.

SIGNATURE PAGE:

[Signature]  
Applicant's Signature

11/14/2023  
Date

THE STATE OF Texas §  
County of Comal §

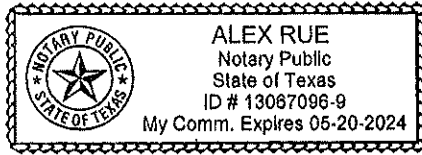

BEFORE ME, the undersigned authority, on this day personally appeared Garrett Mechler known to me to be the person whose name is subscribed to the foregoing instrument, and acknowledged to me that (s)he executed same for the purpose and consideration therein expressed.

GIVEN under my hand and seal of office on this 14 day of November, 2023.

[Signature]  
NOTARY PUBLIC

Alex Rue  
Typed or Printed Name of Notary

MY COMMISSION EXPIRES: 5/20/2024

# Application Fee Form

Texas Commission on Environmental Quality

Name of Proposed Regulated Entity: Veramendi Precincts 18-2 & 19-1

Regulated Entity Location: 3600 LF North of the Intersection between Loop 337 & River Rd

Name of Customer: Veramendi PE-Emerald LLC

Contact Person: Garrett Mechler

Phone: 830 660 4755

Customer Reference Number (if issued): CN 606123701

Regulated Entity Reference Number (if issued): RN \_\_\_\_\_

**Austin Regional Office (3373)**

Hays

Travis

Williamson

**San Antonio Regional Office (3362)**

Bexar

Medina

Uvalde

Comal

Kinney

Application fees must be paid by check, certified check, or money order, payable to the **Texas Commission on Environmental Quality**. Your canceled check will serve as your receipt. **This form must be submitted with your fee payment.** This payment is being submitted to:

Austin Regional Office

San Antonio Regional Office

Mailed to: TCEQ - Cashier

Overnight Delivery to: TCEQ - Cashier

Revenues Section

12100 Park 35 Circle

Mail Code 214

Building A, 3rd Floor

P.O. Box 13088

Austin, TX 78753

Austin, TX 78711-3088

(512)239-0357

**Site Location (Check All That Apply):**

Recharge Zone

Contributing Zone

Transition Zone

<i>Type of Plan</i>	<i>Size</i>	<i>Fee Due</i>
Water Pollution Abatement Plan, Contributing Zone Plan: One Single Family Residential Dwelling	Acres	\$
Water Pollution Abatement Plan, Contributing Zone Plan: Multiple Single Family Residential and Parks	Acres	\$
Water Pollution Abatement Plan, Contributing Zone Plan: Non-residential	Acres	\$
Sewage Collection System	9,670 L.F.	\$ 4,835
Lift Stations without sewer lines	Acres	\$
Underground or Aboveground Storage Tank Facility	Tanks	\$
Piping System(s)(only)	Each	\$
Exception	Each	\$
Extension of Time	Each	\$

Signature: 

Date: 11/14/2023

# Application Fee Schedule

Texas Commission on Environmental Quality

Edwards Aquifer Protection Program 30 TAC Chapter 213 (effective 05/01/2008)

## *Water Pollution Abatement Plans and Modifications*

### *Contributing Zone Plans and Modifications*

<i>Project</i>	<i>Project Area in Acres</i>	<i>Fee</i>
One Single Family Residential Dwelling	< 5	\$650
Multiple Single Family Residential and Parks	< 5	\$1,500
	5 < 10	\$3,000
	10 < 40	\$4,000
	40 < 100	\$6,500
	100 < 500	\$8,000
	≥ 500	\$10,000
Non-residential (Commercial, industrial, institutional, multi-family residential, schools, and other sites where regulated activities will occur)	< 1	\$3,000
	1 < 5	\$4,000
	5 < 10	\$5,000
	10 < 40	\$6,500
	40 < 100	\$8,000
	≥ 100	\$10,000

### *Organized Sewage Collection Systems and Modifications*

<i>Project</i>	<i>Cost per Linear Foot</i>	<i>Minimum Fee- Maximum Fee</i>
Sewage Collection Systems	\$0.50	\$650 - \$6,500

### *Underground and Aboveground Storage Tank System Facility Plans and Modifications*

<i>Project</i>	<i>Cost per Tank or Piping System</i>	<i>Minimum Fee- Maximum Fee</i>
Underground and Aboveground Storage Tank Facility	\$650	\$650 - \$6,500

### *Exception Requests*

<i>Project</i>	<i>Fee</i>
Exception Request	\$500

### *Extension of Time Requests*

<i>Project</i>	<i>Fee</i>
Extension of Time Request	\$150



# TCEQ Core Data Form

For detailed instructions on completing this form, please read the Core Data Form instructions or call 512-239-5175.

## SECTION I: General Information

1. Reason for Submission (If other is checked please describe in space provided.)		
<input type="checkbox"/> New Permit, Registration or Authorization (Core Data Form should be submitted with the program application.)		
<input type="checkbox"/> Renewal (Core Data Form should be submitted with the renewal form)		<input type="checkbox"/> Other
2. Customer Reference Number (if issued)	Follow this link to search for CN or RN numbers in Central Registry**	3. Regulated Entity Reference Number (if issued)
CN 606123701		RN

## SECTION II: Customer Information

4. General Customer Information		5. Effective Date for Customer Information Updates (mm/dd/yyyy)		11/3/2023	
<input type="checkbox"/> New Customer		<input checked="" type="checkbox"/> Update to Customer Information		<input type="checkbox"/> Change in Regulated Entity Ownership	
<input type="checkbox"/> Change in Legal Name (Verifiable with the Texas Secretary of State or Texas Comptroller of Public Accounts)					
The Customer Name submitted here may be updated automatically based on what is current and active with the Texas Secretary of State (SOS) or Texas Comptroller of Public Accounts (CPA).					
6. Customer Legal Name (If an individual, print last name first: eg: Doe, John)				If new Customer, enter previous Customer below:	
VERAMENDI PE-EMERALD LLC					
7. TX SOS/CPA Filing Number		8. TX State Tax ID (11 digits)		9. Federal Tax ID	10. DUNS Number (if applicable)
0803277761		32070223675		(9 digits)	
11. Type of Customer:		<input type="checkbox"/> Corporation		<input type="checkbox"/> Individual	
Government: <input type="checkbox"/> City <input type="checkbox"/> County <input type="checkbox"/> Federal <input type="checkbox"/> Local <input type="checkbox"/> State <input type="checkbox"/> Other		<input type="checkbox"/> Sole Proprietorship		Partnership: <input type="checkbox"/> General <input checked="" type="checkbox"/> Limited	
12. Number of Employees				13. Independently Owned and Operated?	
<input checked="" type="checkbox"/> 0-20 <input type="checkbox"/> 21-100 <input type="checkbox"/> 101-250 <input type="checkbox"/> 251-500 <input type="checkbox"/> 501 and higher				<input checked="" type="checkbox"/> Yes <input type="checkbox"/> No	
14. Customer Role (Proposed or Actual) – as it relates to the Regulated Entity listed on this form. Please check one of the following					
<input type="checkbox"/> Owner		<input type="checkbox"/> Operator		<input type="checkbox"/> Owner & Operator	
<input type="checkbox"/> Occupational Licensee		<input type="checkbox"/> Responsible Party		<input type="checkbox"/> VCP/BSA Applicant	
<input checked="" type="checkbox"/> Other: Vice President					
15. Mailing Address: 387 W Mill St, Ste 108					
Address:					
City	New Braunfels		State	TX	ZIP
					78130
				ZIP + 4	
16. Country Mailing Information (if outside USA)				17. E-Mail Address (if applicable)	
				garrett.mechler@asaproperties.us.com	
18. Telephone Number		19. Extension or Code		20. Fax Number (if applicable)	

**SECTION III: Regulated Entity Information****21. General Regulated Entity Information** (If "New Regulated Entity" is selected, a new permit application is also required.) New Regulated Entity     Update to Regulated Entity Name     Update to Regulated Entity Information*The Regulated Entity Name submitted may be updated, in order to meet TCEQ Core Data Standards (removal of organizational endings such as Inc, LP, or LLC).***22. Regulated Entity Name** (Enter name of the site where the regulated action is taking place.)

Veramendi Precincts 18-2 &amp; 19-1

**23. Street Address of the Regulated Entity:***(No PO Boxes)*

City

State

ZIP

ZIP + 4

**24. County**

If no Street Address is provided, fields 25-28 are required.

**25. Description to Physical Location:**

3600 LF North of the Intersection between Loop 337 and River Rd.

**26. Nearest City**

State

Nearest ZIP Code

New Braunfels

TX

78130

*Latitude/Longitude are required and may be added/updated to meet TCEQ Core Data Standards. (Geocoding of the Physical Address may be used to supply coordinates where none have been provided or to gain accuracy).***27. Latitude (N) In Decimal:**

29.737275

**28. Longitude (W) In Decimal:**

98.140564

Degrees

Minutes

Seconds

Degrees

Minutes

Seconds

29

44

14.19

98

8

26.03

**29. Primary SIC Code****30. Secondary SIC Code****31. Primary NAICS Code****32. Secondary NAICS Code**

(4 digits)

(4 digits)

(5 or 6 digits)

(5 or 6 digits)

1521

**33. What is the Primary Business of this entity?** (Do not repeat the SIC or NAICS description.)

Single Family Houses

**34. Mailing****Address:**

City

State

ZIP

ZIP + 4

**35. E-Mail Address:****36. Telephone Number****37. Extension or Code****38. Fax Number** (if applicable)

( ) -

( ) -

**39. TCEQ Programs and ID Numbers** Check all Programs and write in the permits/registration numbers that will be affected by the updates submitted on this form. See the Core Data Form instructions for additional guidance.

<input type="checkbox"/> Dam Safety	<input type="checkbox"/> Districts	<input type="checkbox"/> Edwards Aquifer	<input type="checkbox"/> Emissions Inventory Air	<input type="checkbox"/> Industrial Hazardous Waste
<input type="checkbox"/> Municipal Solid Waste	<input type="checkbox"/> New Source Review Air	<input type="checkbox"/> OSSF	<input type="checkbox"/> Petroleum Storage Tank	<input type="checkbox"/> PWS
<input type="checkbox"/> Sludge	<input type="checkbox"/> Storm Water	<input type="checkbox"/> Title V Air	<input type="checkbox"/> Tires	<input type="checkbox"/> Used Oil
<input type="checkbox"/> Voluntary Cleanup	<input type="checkbox"/> Wastewater	<input type="checkbox"/> Wastewater Agriculture	<input type="checkbox"/> Water Rights	<input type="checkbox"/> Other:

**SECTION IV: Preparer Information**

40. Name:	LJA Engineering	41. Title:	Engineer
42. Telephone Number	43. Ext./Code	44. Fax Number	45. E-Mail Address
( 210 ) 503-2700		( ) -	pflores@lja.com

**SECTION V: Authorized Signature**

46. By my signature below, I certify, to the best of my knowledge, that the information provided in this form is true and complete, and that I have signature authority to submit this form on behalf of the entity specified in Section II, Field 6 and/or as required for the updates to the ID numbers identified in field 39.

Company:	Veramendi PE - Emerald	Job Title:	VP of Operations
Name (In Print):	Garrett Meckler	Phone:	4301660-4755
Signature:		Date:	11/14/2023