

# **TERALTA PHASE II**

## **Water Pollution Abatement Plan Modification and Sewage Collection System Application**

**April 2024**



April 9, 2024

Ms. Lillian Butler  
Texas Commission on Environmental Quality (TCEQ)  
Region 13  
14250 Judson Road  
San Antonio, Texas 78233-4480

Re: Teralta Phase II  
Water Pollution Abatement Plan Modification and Sewage Collection System Application

Dear Ms. Butler:

Please find included herein the Teralta Phase II Water Pollution Abatement Plan Modification and Sewage Collection System Application. This Water Pollution Abatement Plan Modification has been prepared in accordance with the regulations of the Texas Administrative Code (30 TAC 213) and current policies for development over the Edwards Aquifer Recharge Zone. This Sewage Collection System Application has been prepared to be consistent with the regulations of the Texas Administrative Code (30 TAC 213, 217 and 290) and current policies for development over the Edwards Aquifer Recharge Zone.

This Water Pollution Abatement Plan Modification applies to an approximate 6.83-acre site as identified by the project limits (12.72 ac legal limit). This Sewage Collection System Application applies to the 157 linear feet of sewer main proposed as part of this project. Please review the plan information for the items it is intended to address. If acceptable, please provide a written approval of the plan in order that construction may begin at the earliest opportunity.

Appropriate review fees (\$6,500 and \$650) and fee application are included. If you have questions or require additional information, please do not hesitate to contact me at your earliest convenience.

Sincerely,  
Pape-Dawson Consulting Engineers, LLC  
Texas Registered Engineering Firm # 470



Andrew Belton, P.E.  
Vice President

Attachments

# TERALTA PHASE II

## Water Pollution Abatement Plan Modification and Sewage Collection System Application

*Andrew B*



April 2024

**EDWARDS AQUIFER  
APPLICATION COVER PAGE  
(TCEQ-20705)**

# Texas Commission on Environmental Quality

## Edwards Aquifer Application Cover Page

---

### Our Review of Your Application

**The Edwards Aquifer Program staff conducts an administrative and technical review of all applications. The turnaround time for administrative review can be up to 30 days as outlined in 30 TAC 213.4(e). Generally administrative completeness is determined during the intake meeting or within a few days of receipt. The turnaround time for technical review of an administratively complete Edwards Aquifer application is 90 days as outlined in 30 TAC 213.4(e). Please know that the review and approval time is directly impacted by the quality and completeness of the initial application that is received. In order to conduct a timely review, it is imperative that the information provided in an Edwards Aquifer application include final plans, be accurate, complete, and in compliance with [30 TAC 213](#).**

### Administrative Review

1. [Edwards Aquifer applications](#) must be deemed administratively complete before a technical review can begin. To be considered administratively complete, the application must contain completed forms and attachments, provide the requested information, and meet all the site plan requirements. The submitted application and plan sheets should be final plans. Please submit one full-size set of plan sheets with the original application, and half-size sets with the additional copies.

To ensure that all applicable documents are included in the application, the program has developed tools to guide you and web pages to provide all forms, checklists, and guidance. Please visit the below website for assistance: <http://www.tceq.texas.gov/field/eapp>.

2. This Edwards Aquifer Application Cover Page form (certified by the applicant or agent) must be included in the application and brought to the administrative review meeting.
3. Administrative reviews are scheduled with program staff who will conduct the review. Applicants or their authorized agent should call the appropriate regional office, according to the county in which the project is located, to schedule a review. The average meeting time is one hour.
4. In the meeting, the application is examined for administrative completeness. Deficiencies will be noted by staff and emailed or faxed to the applicant and authorized agent at the end of the meeting, or shortly after. Administrative deficiencies will cause the application to be deemed incomplete and returned.

An appointment should be made to resubmit the application. The application is re-examined to ensure all deficiencies are resolved. The application will only be deemed administratively complete when all administrative deficiencies are addressed.

5. If an application is received by mail, courier service, or otherwise submitted without a review meeting, the administrative review will be conducted within 30 days. The applicant and agent will be contacted with the results of the administrative review. If the application is found to be administratively incomplete, it can be retrieved from the regional office or returned by regular mail. If returned by mail, the regional office may require arrangements for return shipping.
6. If the geologic assessment was completed before October 1, 2004 and the site contains “possibly sensitive” features, the assessment must be updated in accordance with the *Instructions to Geologists* (TCEQ-0585 Instructions).

### Technical Review

1. When an application is deemed administratively complete, the technical review period begins. The regional office will distribute copies of the application to the identified affected city, county, and groundwater conservation district whose jurisdiction includes the subject site. These entities and the public have 30 days to provide comments on the application to the regional office. All comments received are reviewed by TCEQ.
2. A site assessment is usually conducted as part of the technical review, to evaluate the geologic assessment and observe existing site conditions. The site must be accessible to our staff. The site boundaries should be

clearly marked, features identified in the geologic assessment should be flagged, roadways marked and the alignment of the Sewage Collection System and manholes should be staked at the time the application is submitted. If the site is not marked the application may be returned.

3. We evaluate the application for technical completeness and contact the applicant and agent via Notice of Deficiency (NOD) to request additional information and identify technical deficiencies. There are two deficiency response periods available to the applicant. There are 14 days to resolve deficiencies noted in the first NOD. If a second NOD is issued, there is an additional 14 days to resolve deficiencies. If the response to the second notice is not received, is incomplete or inadequate, or provides new information that is incomplete or inadequate, the application must be withdrawn or will be denied. Please note that because the technical review is underway, whether the application is withdrawn or denied **the application fee will be forfeited.**
4. The program has 90 calendar days to complete the technical review of the application. If the application is technically adequate, such that it complies with the Edwards Aquifer rules, and is protective of the Edwards Aquifer during and after construction, an approval letter will be issued. Construction or other regulated activity may not begin until an approval is issued.

### Mid-Review Modifications

It is important to have final site plans prior to beginning the permitting process with TCEQ to avoid delays.

Occasionally, circumstances arise where you may have significant design and/or site plan changes after your Edwards Aquifer application has been deemed administratively complete by TCEQ. This is considered a “Mid-Review Modification”. Mid-Review Modifications may require redistribution of an application that includes the proposed modifications for public comment.

If you are proposing a Mid-Review Modification, two options are available:

- If the technical review has begun your application can be denied/withdrawn, your fees will be forfeited, and the plan will have to be resubmitted.
- TCEQ can continue the technical review of the application as it was submitted, and a modification application can be submitted at a later time.

If the application is denied/withdrawn, the resubmitted application will be subject to the administrative and technical review processes and will be treated as a new application. The application will be redistributed to the affected jurisdictions.

Please contact the regional office if you have questions. If your project is located in Williamson, Travis, or Hays County, contact TCEQ’s Austin Regional Office at 512-339-2929. If your project is in Comal, Bexar, Medina, Uvalde, or Kinney County, contact TCEQ’s San Antonio Regional Office at 210-490-3096

Please fill out all required fields below and submit with your application.

<b>1. Regulated Entity Name:</b>				<b>2. Regulated Entity No.:</b>					
<b>3. Customer Name:</b>				<b>4. Customer No.:</b>					
<b>5. Project Type:</b> (Please circle/check one)	New	Modification		Extension	Exception				
<b>6. Plan Type:</b> (Please circle/check one)	WPAP	CZP	SCS	UST	AST	EXP	EXT	Technical Clarification	Optional Enhanced Measures
<b>7. Land Use:</b> (Please circle/check one)	Residential	Non-residential			<b>8. Site (acres):</b>				
<b>9. Application Fee:</b>				<b>10. Permanent BMP(s):</b>					
<b>11. SCS (Linear Ft.):</b>				<b>12. AST/UST (No. Tanks):</b>					
<b>13. County:</b>				<b>14. Watershed:</b>					

# Application Distribution

Instructions: Use the table below to determine the number of applications required. One original and one copy of the application, plus additional copies (as needed) for each affected incorporated city, county, and groundwater conservation district are required. Linear projects or large projects, which cross into multiple jurisdictions, can require additional copies. Refer to the “Texas Groundwater Conservation Districts within the EAPP Boundaries” map found at:

[http://www.tceq.texas.gov/assets/public/compliance/field\\_ops/eapp/EAPP%20GWCD%20map.pdf](http://www.tceq.texas.gov/assets/public/compliance/field_ops/eapp/EAPP%20GWCD%20map.pdf)

For more detailed boundaries, please contact the conservation district directly.

<b>Austin Region</b>			
<b>County:</b>	<b>Hays</b>	<b>Travis</b>	<b>Williamson</b>
Original (1 req.)	—	—	—
Region (1 req.)	—	—	—
County(ies)	—	—	—
Groundwater Conservation District(s)	<input type="checkbox"/> Edwards Aquifer Authority <input type="checkbox"/> Barton Springs/ Edwards Aquifer <input type="checkbox"/> Hays Trinity <input type="checkbox"/> Plum Creek	<input type="checkbox"/> Barton Springs/ Edwards Aquifer	NA
City(ies) Jurisdiction	<input type="checkbox"/> Austin <input type="checkbox"/> Buda <input type="checkbox"/> Dripping Springs <input type="checkbox"/> Kyle <input type="checkbox"/> Mountain City <input type="checkbox"/> San Marcos <input type="checkbox"/> Wimberley <input type="checkbox"/> Woodcreek	<input type="checkbox"/> Austin <input type="checkbox"/> Bee Cave <input type="checkbox"/> Pflugerville <input type="checkbox"/> Rollingwood <input type="checkbox"/> Round Rock <input type="checkbox"/> Sunset Valley <input type="checkbox"/> West Lake Hills	<input type="checkbox"/> Austin <input type="checkbox"/> Cedar Park <input type="checkbox"/> Florence <input type="checkbox"/> Georgetown <input type="checkbox"/> Jerrell <input type="checkbox"/> Leander <input type="checkbox"/> Liberty Hill <input type="checkbox"/> Pflugerville <input type="checkbox"/> Round Rock

<b>San Antonio Region</b>					
<b>County:</b>	<b>Bexar</b>	<b>Comal</b>	<b>Kinney</b>	<b>Medina</b>	<b>Uvalde</b>
Original (1 req.)	—	—	—	—	—
Region (1 req.)	—	—	—	—	—
County(ies)	—	—	—	—	—
Groundwater Conservation District(s)	<input type="checkbox"/> Edwards Aquifer Authority <input type="checkbox"/> Trinity-Glen Rose	<input type="checkbox"/> Edwards Aquifer Authority	<input type="checkbox"/> Kinney	<input type="checkbox"/> EAA <input type="checkbox"/> Medina	<input type="checkbox"/> EAA <input type="checkbox"/> Uvalde
City(ies) Jurisdiction	<input type="checkbox"/> Castle Hills <input type="checkbox"/> Fair Oaks Ranch <input type="checkbox"/> Helotes <input type="checkbox"/> Hill Country Village <input type="checkbox"/> Hollywood Park <input type="checkbox"/> San Antonio (SAWS) <input type="checkbox"/> Shavano Park	<input type="checkbox"/> Bulverde <input type="checkbox"/> Fair Oaks Ranch <input type="checkbox"/> Garden Ridge <input type="checkbox"/> New Braunfels <input type="checkbox"/> Schertz	NA	<input type="checkbox"/> San Antonio ETJ (SAWS)	NA

I certify that to the best of my knowledge, that the application is complete and accurate. This application is hereby submitted to TCEQ for administrative review and technical review.

Andrew Belton, P.E.

Print Name of Customer/Authorized Agent

Signature of Customer/Authorized Agent

Date

4/10/24

**FOR TCEQ INTERNAL USE ONLY**			
Date(s) Reviewed:		Date Administratively Complete:	
Received From:		Correct Number of Copies:	
Received By:		Distribution Date:	
EAPP File Number:		Complex:	
Admin. Review(s) (No.):		No. AR Rounds:	
Delinquent Fees (Y/N):		Review Time Spent:	
Lat./Long. Verified:		SOS Customer Verification:	
Agent Authorization Complete/Notarized (Y/N):		Fee Check:	Payable to TCEQ (Y/N):
Core Data Form Complete (Y/N):			Signed (Y/N):
Core Data Form Incomplete Nos.:			Less than 90 days old (Y/N):

**GENERAL INFORMATION  
FORM (TCEQ-0587)**

# General Information Form

## Texas Commission on Environmental Quality

For Regulated Activities on the Edwards Aquifer Recharge and Transition Zones and Relating to 30 TAC §213.4(b) & §213.5(b)(2)(A), (B) Effective June 1, 1999

**To ensure that the application is administratively complete, confirm that all fields in the form are complete, verify that all requested information is provided, consistently reference the same site and contact person in all forms in the application, and ensure forms are signed by the appropriate party.**

**Note: Including all the information requested in the form and attachments contributes to more streamlined technical reviews.**

## Signature

To the best of my knowledge, the responses to this form accurately reflect all information requested concerning the proposed regulated activities and methods to protect the Edwards Aquifer. This **General Information Form** is hereby submitted for TCEQ review. The application was prepared by:

Print Name of Customer/Agent: Andrew Belton, P.E.

Date: 4/10/24

Signature of Customer/Agent:

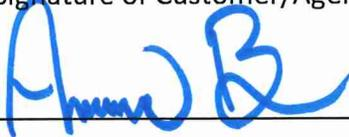

## Project Information

1. Regulated Entity Name: Teralta Phase II
2. County: Bexar
3. Stream Basin: Upper San Antonio
4. Groundwater Conservation District (If applicable): Trinity-Glen Rose
5. Edwards Aquifer Zone:

- Recharge Zone  
 Transition Zone

6. Plan Type:

- WPAP  
 SCS  
 Modification

- AST  
 UST  
 Exception Request

7. Customer (Applicant):

Contact Person: William T. Ellis

Entity: Teralta Partners, Ltd.

Mailing Address: 70 NE Loop 410, Ste 250

City, State: San Antonio, TX

Zip: 78216

Telephone: (210) 402-0800

FAX: (210) 402-0805

Email Address: bellis@sirell.com

8. Agent/Representative (If any):

Contact Person: Andrew Belton, P.E.

Entity: Pape-Dawson Consulting Engineers, LLC

Mailing Address: 2000 NW Loop 410

City, State: San Antonio, Texas

Zip: 78213

Telephone: (210) 375-9000

FAX: (210) 375-9010

Email Address: abelton@pape-dawson.com

9. Project Location:

- The project site is located inside the city limits of San Antonio.
- The project site is located outside the city limits but inside the ETJ (extra-territorial jurisdiction) of \_\_\_\_\_.
- The project site is not located within any city's limits or ETJ.

10.  The location of the project site is described below. The description provides sufficient detail and clarity so that the TCEQ's Regional staff can easily locate the project and site boundaries for a field investigation.

From TCEQ's regional office, travel north on Judson Rd approxiamtely 2.5 miles to Loop 1604. Turn left on to Loop 1604 and travel west approximately 12.2 miles to the Lockhill Selma Rd exit. Travel approximately 0.5 miles on the frontage road. The project site is on the NW corner of Loop 1604 Frontage Rd and Lou Mell Dr intersection.

11.  **Attachment A – Road Map.** A road map showing directions to and the location of the project site is attached. The project location and site boundaries are clearly shown on the map.
12.  **Attachment B - USGS / Edwards Recharge Zone Map.** A copy of the official 7 ½ minute USGS Quadrangle Map (Scale: 1" = 2000') of the Edwards Recharge Zone is attached. The map(s) clearly show:
- Project site boundaries.
  - USGS Quadrangle Name(s).
  - Boundaries of the Recharge Zone (and Transition Zone, if applicable).
  - Drainage path from the project site to the boundary of the Recharge Zone.
13.  **The TCEQ must be able to inspect the project site or the application will be returned.** Sufficient survey staking is provided on the project to allow TCEQ regional staff to locate

the boundaries and alignment of the regulated activities and the geologic or manmade features noted in the Geologic Assessment.

Survey staking will be completed by this date: February 2016

14.  **Attachment C – Project Description.** Attached at the end of this form is a detailed narrative description of the proposed project. The project description is consistent throughout the application and contains, at a minimum, the following details:

- Area of the site
- Offsite areas
- Impervious cover
- Permanent BMP(s)
- Proposed site use
- Site history
- Previous development
- Area(s) to be demolished

15. Existing project site conditions are noted below:

- Existing commercial site
- Existing industrial site
- Existing residential site
- Existing paved and/or unpaved roads
- Undeveloped (Cleared)
- Undeveloped (Undisturbed/Uncleared)
- Other: \_\_\_\_\_

### ***Prohibited Activities***

16.  I am aware that the following activities are prohibited on the Recharge Zone and are not proposed for this project:

- (1) Waste disposal wells regulated under 30 TAC Chapter 331 of this title (relating to Underground Injection Control);
- (2) New feedlot/concentrated animal feeding operations, as defined in 30 TAC §213.3;
- (3) Land disposal of Class I wastes, as defined in 30 TAC §335.1;
- (4) The use of sewage holding tanks as parts of organized collection systems; and
- (5) New municipal solid waste landfill facilities required to meet and comply with Type I standards which are defined in §330.41(b), (c), and (d) of this title (relating to Types of Municipal Solid Waste Facilities).
- (6) New municipal and industrial wastewater discharges into or adjacent to water in the state that would create additional pollutant loading.

17.  I am aware that the following activities are prohibited on the Transition Zone and are not proposed for this project:

- (1) Waste disposal wells regulated under 30 TAC Chapter 331 (relating to Underground Injection Control);
- (2) Land disposal of Class I wastes, as defined in 30 TAC §335.1; and
- (3) New municipal solid waste landfill facilities required to meet and comply with Type I standards which are defined in §330.41 (b), (c), and (d) of this title.

### ***Administrative Information***

18. The fee for the plan(s) is based on:

- For a Water Pollution Abatement Plan or Modification, the total acreage of the site where regulated activities will occur.
- For an Organized Sewage Collection System Plan or Modification, the total linear footage of all collection system lines.
- For a UST Facility Plan or Modification or an AST Facility Plan or Modification, the total number of tanks or piping systems.
- A request for an exception to any substantive portion of the regulations related to the protection of water quality.
- A request for an extension to a previously approved plan.

19.  Application fees are due and payable at the time the application is filed. If the correct fee is not submitted, the TCEQ is not required to consider the application until the correct fee is submitted. Both the fee and the Edwards Aquifer Fee Form have been sent to the Commission's:

- TCEQ cashier
- Austin Regional Office (for projects in Hays, Travis, and Williamson Counties)
- San Antonio Regional Office (for projects in Bexar, Comal, Kinney, Medina, and Uvalde Counties)

20.  Submit one (1) original and one (1) copy of the application, plus additional copies as needed for each affected incorporated city, groundwater conservation district, and county in which the project will be located. The TCEQ will distribute the additional copies to these jurisdictions. The copies must be submitted to the appropriate regional office.

21.  No person shall commence any regulated activity until the Edwards Aquifer Protection Plan(s) for the activity has been filed with and approved by the Executive Director.

**ATTACHMENT A**

# TERALTA PHASE II Water Pollution Abatement Plan Modification

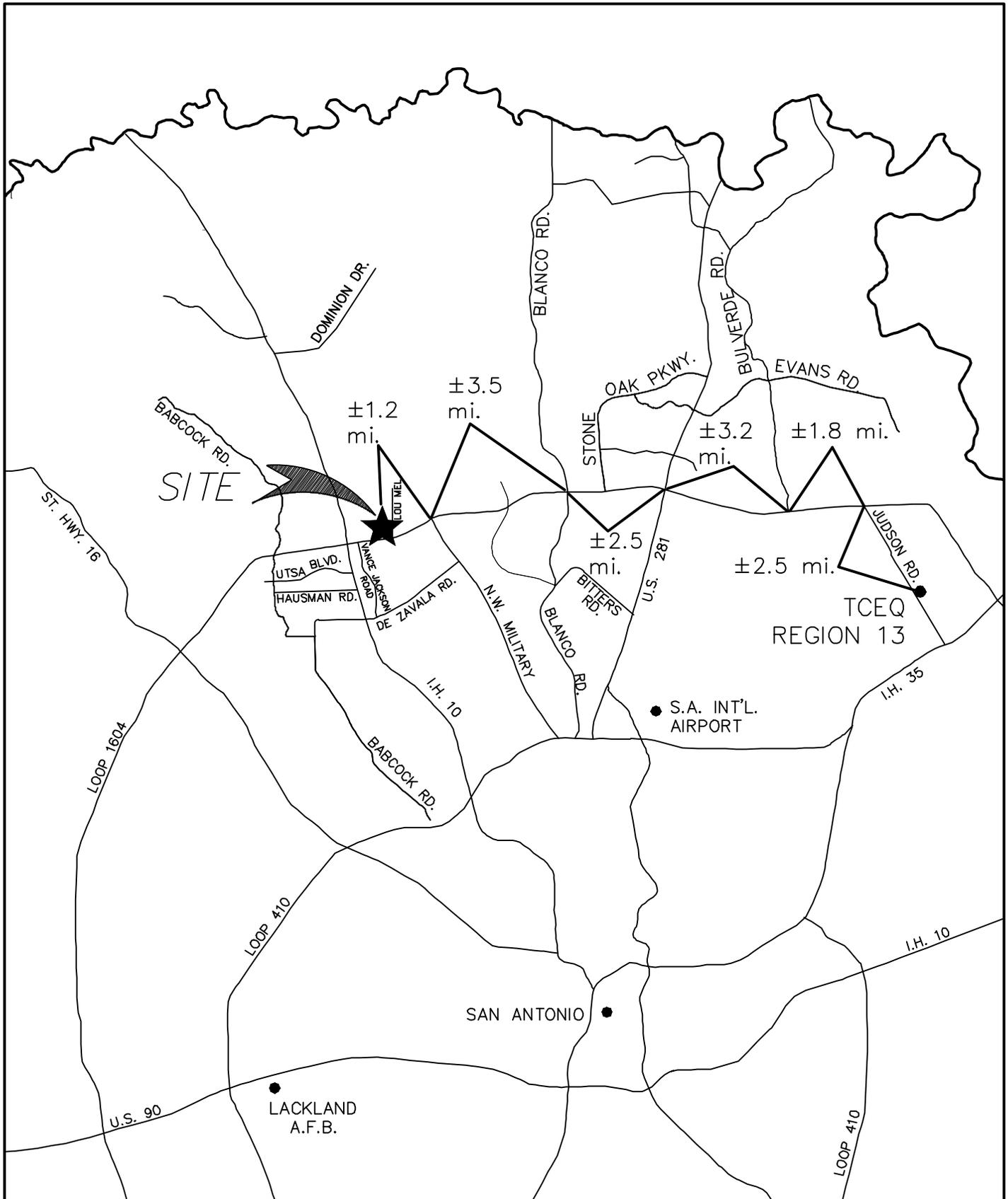

**ATTACHMENT B**

TERALTA PHASE II  
Water Pollution Abatement Plan Modification

  
SCALE: 1" = 2000'

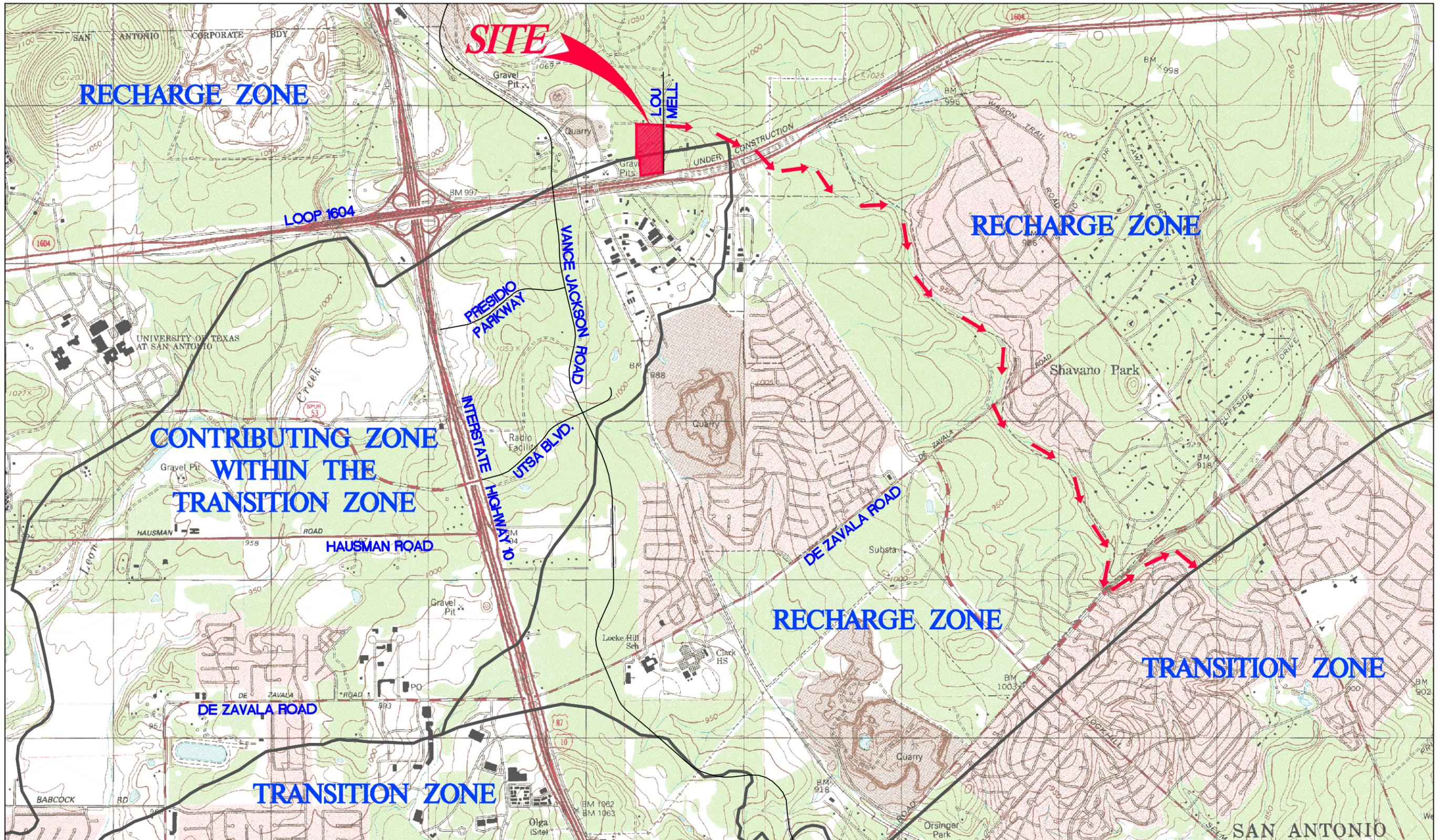

Date: Apr 01, 2024, 2:22pm User: id: mgregory  
File: P:\871\01\Design\Environment\WPAP\0877101.dwg

**ATTACHMENT C**

# TERALTA PHASE II

## Water Pollution Abatement Plan Modification

### Attachment C – Project Description

Teralta Phase II Water Pollution Abatement Plan (WPAP) is a modification of the previously approved Teralta Corporate Park (ID 13000111), which approved a commercial development on an approximately 12.72-acre legal limit with 9.51 acres of impervious cover. This Teralta Phase II proposes the second phase of this development, with additional buildings, parking and drives on a project site of 6.23 acres. The site is located at 4949 N Loop 1604 W, San Antonio, Texas, and is over both the Edwards Aquifer Recharge Zone and Contributing Zone within the Transition Zone. There are five (5) manmade sensitive geologic features and no naturally occurring sensitive features as identified by the Geologic Assessment.

This WPAP proposes additional clearing, grading, excavation, installation of utilities and drainage improvements for the construction of three (3) commercial buildings with associated parking and drives. An inlet with a headwall and splashpad are proposed to route the stormwater for this phase to the existing sedimentation basin. The location of the gate on the basin is proposed to be relocated, but no other modifications to the basin are proposed. These proposed improvements will add 3.569 acres of impervious cover to the existing 5.011 acres of impervious cover from the first phase of development. The total impervious cover for this 12.72-acre legal limit site is 8.58 acres, or 67.5% of the overall development. The proposed Permanent Best Management Practices (PBMPs) for stormwater treatment are one (1) existing, approved sedimentation basin (ID 13000111) and one (1) existing, approved fifteen-foot (15') engineered vegetative filter strip (ID 13000111), which were designed in accordance with the TCEQ's Technical Guidance Manual (TGM) RG-348 (2005) to remove 80% of the increase in Total Suspended Solids (TSS) from the site. The previously approved VFS "D" (ID 13000111) is proposed to be removed and treatment for this area is now provided by the existing sedimentation basin, which has been sized accordingly. In Watershed "B," approximately 0.10 acres of impervious cover from the proposed driveway will be treated via overtreatment from the existing basin. Please see the Treatment Summary table attached with this application.

The Teralta Phase II Sewage Collection System (SCS) application proposes the construction of a total of approximately 157 linear feet (LF) of sanitary sewer main to serve the commercial development. Regulated activities proposed include excavation, installation of sewer mains and manholes, backfill, and compaction. Approximately 0.36 acres may be disturbed as identified by the 50-foot envelope shown on the plans; however, an overall 6.23 acres may be disturbed for this phase of development.

Potable water service is to be provided by the San Antonio Water System (SAWS). The proposed development will generate approximately 13,200 gallons per day (average flow) of domestic wastewater based on the assumption of 200 gpd per EDU (66 EDU \* 200 gpd/EDU = 13,200 gpd). Wastewater will be disposed of by conveyance to the existing Steven M. Clouse Water Recycling Center operated by SAWS.

**GEOLOGIC ASSESSMENT FORM**  
**(TCEQ-0585)**

# Geologic Assessment

## Texas Commission on Environmental Quality

For Regulated Activities on The Edwards Aquifer Recharge/transition Zones and Relating to 30 TAC §213.5(b)(3), Effective June 1, 1999

*To ensure that the application is administratively complete, confirm that all fields in the form are complete, verify that all requested information is provided, consistently reference the same site and contact person in all forms in the application, and ensure forms are signed by the appropriate party.*

*Note: Including all the information requested in the form and attachments contributes to more streamlined technical reviews.*

## Signature

To the best of my knowledge, the responses to this form accurately reflect all information requested concerning the proposed regulated activities and methods to protect the Edwards Aquifer. My signature certifies that I am qualified as a geologist as defined by 30 TAC Chapter 213.

Print Name of Geologist: Amanda L. Miller

Telephone: 210-375-9000

Date: 15 Oct. 2015

Fax: 210-375-9090

Representing: Pape-Dawson Engineers, Inc.

Texas Board of Professional Geoscientists No. 50351 (Name of Company and TBPG or TBPE registration number)

Signature of Geologist:

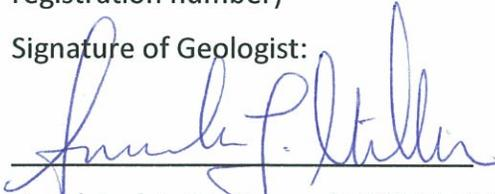

Regulated Entity Name: TERALTA OFFICE COMPLEX

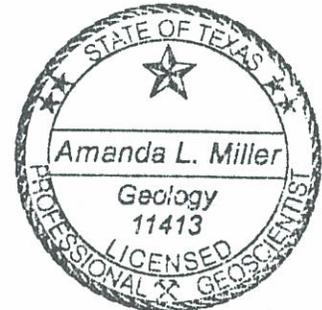

## Project Information

1. Date(s) Geologic Assessment was performed: April 14 and July 14, 2015

2. Type of Project:

WPAP

AST

SCS

UST

3. Location of Project:

Recharge Zone

Transition Zone

Contributing Zone within the Transition Zone

4.  **Attachment A - Geologic Assessment Table.** Completed Geologic Assessment Table (Form TCEQ-0585-Table) is attached.
5.  Soil cover on the project site is summarized in the table below and uses the SCS Hydrologic Soil Groups\* (Urban Hydrology for Small Watersheds, Technical Release No. 55, Appendix A, Soil Conservation Service, 1986). If there is more than one soil type on the project site, show each soil type on the site Geologic Map or a separate soils map.

**Table 1 - Soil Units, Infiltration Characteristics and Thickness**

Soil Name	Group*	Thickness(feet)
Crawford and Bexar stony soils (Cb)	D	0-3
Lewisville silty clay, 1 to 3 percent slopes (LvB)	D	0-2.5

Soil Name	Group*	Thickness(feet)

*\* Soil Group Definitions (Abbreviated)*

- A. Soils having a high infiltration rate when thoroughly wetted.
- B. Soils having a moderate infiltration rate when thoroughly wetted.
- C. Soils having a slow infiltration rate when thoroughly wetted.
- D. Soils having a very slow infiltration rate when thoroughly wetted.

6.  **Attachment B – Stratigraphic Column.** A stratigraphic column showing formations, members, and thicknesses is attached. The outcropping unit, if present, should be at the top of the stratigraphic column. Otherwise, the uppermost unit should be at the top of the stratigraphic column.
7.  **Attachment C – Site Geology.** A narrative description of the site specific geology including any features identified in the Geologic Assessment Table, a discussion of the potential for fluid movement to the Edwards Aquifer, stratigraphy, structure(s), and karst characteristics is attached.
8.  **Attachment D – Site Geologic Map(s).** The Site Geologic Map must be the same scale as the applicant's Site Plan. The minimum scale is 1": 400'  
 Applicant's Site Plan Scale: 1" = 50'  
 Site Geologic Map Scale: 1" = 50'  
 Site Soils Map Scale (if more than 1 soil type): 1" = 200'

9. Method of collecting positional data:

- Global Positioning System (GPS) technology.  
 Other method(s). Please describe method of data collection: \_\_\_\_\_

10.  The project site and boundaries are clearly shown and labeled on the Site Geologic Map.
11.  Surface geologic units are shown and labeled on the Site Geologic Map.
12.  Geologic or manmade features were discovered on the project site during the field investigation. They are shown and labeled on the Site Geologic Map and are described in the attached Geologic Assessment Table.
- Geologic or manmade features were not discovered on the project site during the field investigation.
13.  The Recharge Zone boundary is shown and labeled, if appropriate.
14. All known wells (test holes, water, oil, unplugged, capped and/or abandoned, etc.): If applicable, the information must agree with Item No. 20 of the WPAP Application Section.
- There are 1 (#) wells present on the project site and the locations are shown and labeled. (Check all of the following that apply.)
- The wells are not in use and have been properly abandoned.
- The wells are not in use and will be properly abandoned.
- The wells are in use and comply with 16 TAC Chapter 76.
- There are no wells or test holes of any kind known to exist on the project site.

### ***Administrative Information***

15.  Submit one (1) original and one (1) copy of the application, plus additional copies as needed for each affected incorporated city, groundwater conservation district, and county in which the project will be located. The TCEQ will distribute the additional copies to these jurisdictions. The copies must be submitted to the appropriate regional office.

**ATTACHMENT A**

PROJECT NAME: TERALTA OFFICE COMPLEX

GEOLOGIC ASSESSMENT TABLE

LOCATION		FEATURE CHARACTERISTICS										EVALUATION			PHYSICAL SETTING		
1A	1B*	1C*	2A	2B	3	4			5	6	7	8A	8B	9	10	11	12
FEATURE ID	LATITUDE	LONGITUDE	FEATURE TYPE	POINTS	FORMATION	DIMENSIONS (FEET)			TREND (DEGREES)	DOM	APERTURE (FEET)	INFILLING	RELATIVE INFILTRATION RATE	TOTAL	SENSITIVITY	CATCHMENT AREA (ACRES)	TOPOGRAPHY
	N	W				X	Y	Z		10				<40	≥50	<1.6	≥1.6
S-1	29°35'36.36"	98°34'56.60"	MB	30	Kbu	5	7	2.5				C,F	20	50	50	X	Hillside
S-2	29°35'36.32"	98°34'56.74"	MB	30	Kbu	10	10	3				C,F	20	50	50	X	Hillside
S-3	29°35'36.12"	98°34'58.20"	CD	5	Kbu	15	15	2				F	5	10	10	X	Hillside
S-4	29°35'35.39"	98°35'0.81"	MB	30	Kbu	5	5	6				C,F	20	50	50	X	Hillside
S-5	29°35'36.93"	98°35'1.14"	CD	5	Kbu	6	6	1				F	5	10	10	X	Hillside
S-6	29°35'36.81"	98°34'56.21"	CD	5	Kbu	15	12	2				F	5	10	10	X	Hillside
S-7	29°35'38.30"	98°35'1.64"	MB	30	Kbu							X	35	65	65	X	Hillside
S-8	29°35'40.84"	98°34'56.40"	CD	5	Kep	12	12	0.5				F	5	10	10	X	Hillside
S-9	29°35'58.87"	98°34'58.88"	F	20	Kep	555			N80°E	10		F	5	35	35	X	Hillside
S-10	29°35'39.30"	98°34'58.53"	F	20	Kep/Kbu	554			N80°E	10		F	5	35	35	X	Hillside
S-11	29°35'37.31"	98°34'59.21"	F	20	Kbu	563			N65°E	10		F	5	35	35	X	Hillside
S-12	29°35'39.48"	98°35'1.046"	MB	30	Kep							X	35	65	65	X	Hillside

\*\* DATUM: NAD 83

Note: Only those geologic and man-made features within that area of the assessment are included. Therefore, the features may not be numbered sequentially.

2A TYPE	TYPE	2B POINTS
C	Cave	30
SC	Solution cavity	20
SF	Solution-enlarged fracture(s)	20
F	Fault	20
O	Other natural bedrock features	5
MB	Manmade feature in bedrock	30
SW	Swallow hole	30
SH	Sinkhole	20
CD	Non-karst closed depression	5
Z	Zone, clustered or aligned features	30

8A INFILLING

- N None, exposed bedrock
- C Coarse - cobbles, breakdown, sand, gravel
- O Loose or soft mud or soil, organics, leaves, sticks, dark colors
- F Fines, compacted clay-rich sediment, soil profile, gray or red colors
- V Vegetation. Give details in narrative description
- FS Flowstone, cements, cave deposits
- X Other materials

12 TOPOGRAPHY

- Cliff, Hilltop, Hillside, Drainage, Floodplain, Streambed

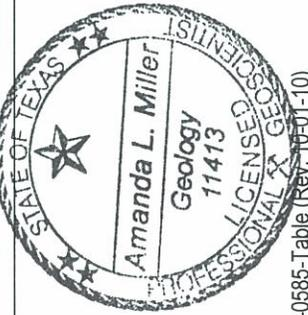

I have read, I understand, and I have followed the Texas Commission on Environmental Quality's Instructions to Geologists. The information presented here complies with that document and is a true representation of the conditions observed in the field. My signature certifies that I am qualified as a geologist as defined by 30 TAC Chapter 213.

*Amanda L. Miller*

Date 15 Oct. 2015

**ATTACHMENT B**

# TERALTA OFFICE COMPLEX

## Stratigraphic Column

[Hydrogeologic subdivisions modified from Maclay and Small (1976); groups, formations, and members modified from Rose (1972); lithology modified from Dunham (1962); and porosity type modified from Choquette and Pray (1970); CU, confining unit; AQ, aquifer]

Hydrogeologic subdivision		Group, formation, or member	Hydrologic function	Thickness (feet)	Lithology	Field Identification	Cavern development	Porosity/permeability type		
Upper	Upper confining units	Buda Limestone (Kbu)	CU	40-50	Buff, light gray, dense mudstone	Porcelaneous limestone with calcite-filled veins	Minor surface karst	Low porosity/low permeability		
		Del Rio Clay (Kdr)	CU	40-50	Blue-green to yellow-brown clay	Fossiliferous; <i>Ilymatogyra arietina</i>	None	None/primary upper confining unit		
Lower Cretaceous	Edwards Aquifer	Edwards Group	I	Georgetown Formation (Kgt)	Karst AQ; no karst CU	2-20	Reddish-brown, gray to light tan marly limestone	Marker fossil; <i>Waconella wacoensis</i>	None	Low porosity/low permeability
			II	Person Formation (Kep)	Cyclic and marine members, undivided	AQ	80-90	Mudstone to packstone; <i>miliolid</i> grainstone; chert	Thin graded cycles; massive beds to relatively thin beds; crossbeds	Many subsurface; might be associated with earlier karst development
		III	Leached and collapsed members, undivided		AQ	70-90	Crystalline limestone; mudstone to grainstone; chert; collapsed breccia	Bioturbated iron-stained beds separated by massive limestone beds; stromatolitic limestone	Extensive lateral development; large rooms	Majority not fabric/one of the most permeable
		IV	Regional dense member		CU	20-24	Dense, argillaceous mudstone	Wispy iron-oxide stains	Very few; only vertical fracture enlargement	Not fabric/low permeability; vertical barrier
		V	Kainer Formation (Ket)	Grainstone member	AQ	50-60	<i>Miliolid</i> grainstone; mudstone to wackestone; chert	White crossbedded grainstone	Few	Not fabric/recrystallization reduces permeability
		VI		Kirschberg evaporite member	AQ	50-60	Highly altered crystalline limestone; chalky mudstone; chert	Boxwork voids, with neospar and travertine frame	Probably extensive cave development	Majority fabric/one of the most permeable
		VII		Dolomitic member	AQ	110-130	Mudstone to grainstone; crystalline limestone; chert	Massively bedded light gray, <i>Toucastia</i> abundant	Caves related to structure or bedding planes	Mostly not fabric; some bedding plane-fabric/water-yielding
		VIII		Basal nodular member	Karst AQ; not karst CU	50-60	Shaly, nodular limestone mudstone and miliolid grainstone	Massive, nodular and mottled, <i>Exogyra texana</i>	Large lateral caves at surface; a few caves near Cibolo Creek	Fabric; stratigraphically controlled/large conduit flow at surface; no permeability in subsurface
			Lower confining unit	Upper member of the Glen Rose Limestone (Kgru)	CU; evaporite beds AQ	350-500	Yellowish tan, thinly bedded limestone and marl	Stair-step topography; alternating limestone and marl	Some surface cave development	Some water production at evaporite beds/relatively impermeable

(Modified from Stein and Ozuna, 1995)

**ATTACHMENT C**

# TERALTA OFFICE COMPLEX

## Site Geology

The northern portion of the site is located within the Edwards Aquifer Recharge Zone and the southern portion is located within the Contributing Zone within the Transition Zone. The overall potential for fluid movement to the Edwards Aquifer for the site is low to moderate. No karst features were identified onsite. The site is highly disturbed by tree clearing activities in the recent past. Historic aerial photographs show a portion in the southern half of the property as farmland between the 1950's and 60's. The site has been developed with a residential house, multiple auxiliary buildings, an AT&T cell phone tower, and an asphalt driveway and parking area. Three faults cross the site with an average dominant trend of N65°E.

The southern portion of the site is located within the Buda Limestone (Kbu), while the remainder of the site is located within the cyclic and marine members (Kepcm) of the Person formation. The Kbu is characterized by buff, light gray, dense mudstone. There is generally only minor to no karst development in the Kbu. The Kepcm is characterized by a mudstone or packstone miliolid grainstone, and chert. Karst development in the Kepcm is characterized by small sinkholes and caves developed as vertical shafts as well as lateral rooms. No caves or sinkholes were identified on site.

### Features S-1, S-2 and S-4

These features are man-made, rock-lined pits that resemble possible hand-dug wells or cisterns. Their exact origin and purpose are unknown, but could be related to past agricultural use. The floors of these features could not be seen entirely due to overgrowth and trash. Since the features are open and exact depths are unknown, the probability of rapid infiltration is intermediate.

### Features S-3, S-5, S-6 and S-8

These features are non-karst closed depressions from past tree removal or other site disturbance. The non-karst origins are presence of fine infilling suggest a low probability of rapid infiltration.

### Feature S-7

Feature S-7 is a water well located south of the existing residence. The well is located on a 2 by 2-foot concrete pad with steel casing, which extends approximately 8 inches above the concrete slab. The well is not capped. Since the well is open, and because the age, integrity and extent of the casing below the ground surface are unknown, the probability for rapid infiltration is high.

### Features S-9 through S-11

These features are faults mapped by historic aerial photographs, published maps and during field investigations at surrounding properties. The northern-most fault (S-9) is an intraformational fault within the Kepcm. The middle fault (S-10) marks the boundary of the Edwards Aquifer Recharge Zone, to the north, from the Contributing Zone within the Transition Zone, to the south. This fault displaces the Kepcm to the north from the Kbu to the south. The southern-most fault (S-11) is an intraformational fault within the Kbu. No areas of enhanced permeability or geologic features associated with these faults were observed during the site visit. Therefore, the probability of rapid infiltration is low.

Feature S-12

Feature S-12 is an underground septic tank. The tank was not observed from the surface and was only identified after interviewing the property owner. However, because the integrity of the tank is unknown, and because the tank sits within the Person formation of the Edwards limestone, the probability of rapid infiltration is high.

**ATTACHMENT D**

# TERALTA OFFICE COMPLEX Geologic Assessment



ATTACHMENT D

BEXAR COUNTY SOIL SURVEY  
2014 AERIAL PHOTOGRAPH  
SCALE: 1"= 200'

**PAPE-DAWSON  
ENGINEERS**

SITE

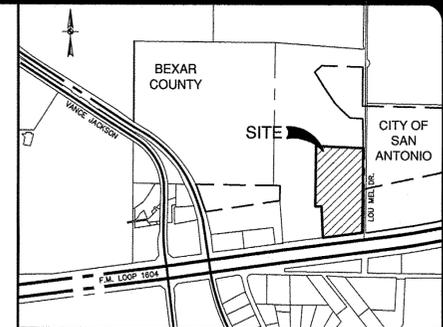
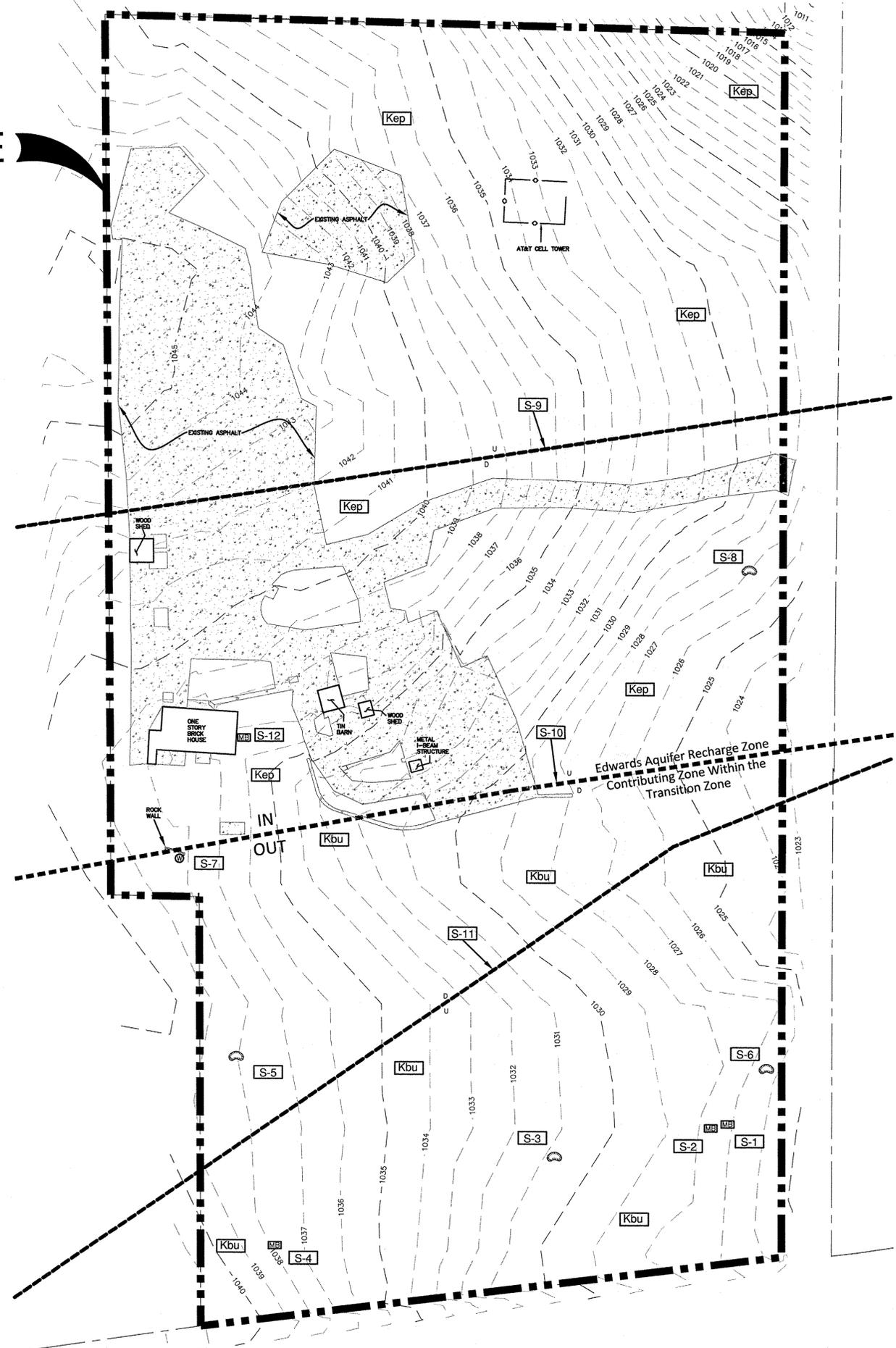

LOCATION MAP  
NOT-TO-SCALE

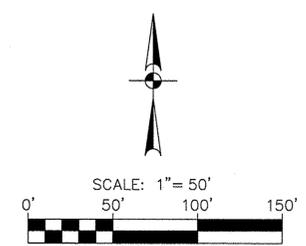

**LEGEND**

	ALLUVIUM
	BUDA LIMESTONE
	DEL RIO CLAY
	GEORGETOWN FORMATION
	PERSON FORMATION
	KAINER FORMATION
	GLEN ROSE FORMATION (UPPER)
	POTENTIAL RECHARGE FEATURE
	DRAINAGE PATHWAY
	CONTACT, LOCATED APPROXIMATELY
	FAULT, LOCATED APPROXIMATELY (D, downthrown side; U, upthrown side)
	FAULT, EXISTENCE UNCERTAIN
	POSSIBLE FAULT (as located by aerial photographs)
	STRIKE AND DIP OF BEDDING
	STRIKE AND DIP OF JOINTS
	STRIKE OF VERTICAL JOINTS
	CAVE
	NON-KARST CLOSED DEPRESSION
	SINKHOLE
	SOLUTION CAVITY
	OTHER NATURAL BEDROCK FEATURES: VUGGY ROCK, REEF DEPOSITS
	ZONE
	MAN-MADE FEATURE IN BEDROCK
	WATER WELL
	SANITARY SEWER LINE

NOTE: THE GEOSCIENTIST SEAL HAS BEEN AFFIXED TO THIS SHEET ONLY FOR PURPOSES OF GEOLOGIC INFORMATION. ALL OTHER INFORMATION SHOULD BE ACQUIRED FROM THE APPROPRIATE SIGNED AND SEALED CIVIL ENGINEERING DRAWINGS.

STATE OF TEXAS  
 Amanda L. Miller  
 Geology  
 11413  
 LICENSED  
 PROFESSIONAL GEOLOGIST  
 15 OCT. 2015

NO.	REVISION	DATE

**PAPE-DAWSON ENGINEERS**  
 2000 NW LOOP 410 | SAN ANTONIO, TEXAS 78213 | PHONE: 210.375.9000  
 TEXAS BOARD OF PROFESSIONAL ENGINEERS, FIRM REGISTRATION # 479  
 TEXAS BOARD OF PROFESSIONAL GEOLOGISTS, FIRM REGISTRATION # 5031

**TERALTA OFFICE COMPLEX**  
 SAN ANTONIO, TEXAS  
 WATER POLLUTION ABATEMENT PLAN  
 SITE GEOLOGIC MAP

JOB NO.	8771-00
DATE	SEPTEMBER 2015
GEOLOGIST	ALM
CHECKED	CT DRAWN ALM
ATTACHMENT D	

Date: Oct 15, 2015, 4:03pm User ID: amiller  
 File: P:\8771\00\Design\Environmental\GA\General\Tract\GA877100.dwg  
 THIS DOCUMENT HAS BEEN PRODUCED FROM MATERIAL THAT WAS STORED AND/OR TRANSMITTED ELECTRONICALLY AND MAY HAVE BEEN INADVERTENTLY ALTERED. RELY ONLY ON FINAL HARDCOPY MATERIALS BEARING THE CONSULTANT'S ORIGINAL SIGNATURE AND SEAL.

**MODIFICATION OF A  
PREVIOUSLY APPROVED  
WATER POLLUTION  
ABATEMENT PLAN (TCEQ-  
0590)**

# Modification of a Previously Approved Plan

## Texas Commission on Environmental Quality

for Regulated Activities on the Edwards Aquifer Recharge Zone and Transition Zone and Relating to 30 TAC 213.4(j), Effective June 1, 1999

*To ensure that the application is administratively complete, confirm that all fields in the form are complete, verify that all requested information is provided, consistently reference the same site and contact person in all forms in the application, and ensure forms are signed by the appropriate party.*

*Note: Including all the information requested in the form and attachments contributes to more streamlined technical reviews.*

## Signature

To the best of my knowledge, the responses to this form accurately reflect all information requested concerning the proposed regulated activities and methods to protect the Edwards Aquifer. This request for a **Modification of a Previously Approved Plan** is hereby submitted for TCEQ review and executive director approval. The request was prepared by:

Print Name of Customer/Agent: Andrew Belton, P.E.

Date: 4/10/24

Signature of Customer/Agent:



## Project Information

1. Current Regulated Entity Name: Teralta Phase II  
Original Regulated Entity Name: Teralta Corpportate Park  
Regulated Entity Number(s) (RN): 109119271  
Edwards Aquifer Protection Program ID Number(s): 13000111  
 The applicant has not changed and the Customer Number (CN) is: 605101831  
 The applicant or Regulated Entity has changed. A new Core Data Form has been provided.
2.  **Attachment A: Original Approval Letter and Approved Modification Letters.** A copy of the original approval letter and copies of any modification approval letters are attached.

3. A modification of a previously approved plan is requested for (check all that apply):
- Physical or operational modification of any water pollution abatement structure(s) including but not limited to ponds, dams, berms, sewage treatment plants, and diversionary structures;
  - Change in the nature or character of the regulated activity from that which was originally approved or a change which would significantly impact the ability of the plan to prevent pollution of the Edwards Aquifer;
  - Development of land previously identified as undeveloped in the original water pollution abatement plan;
  - Physical modification of the approved organized sewage collection system;
  - Physical modification of the approved underground storage tank system;
  - Physical modification of the approved aboveground storage tank system.
4.  Summary of Proposed Modifications (select plan type being modified). If the approved plan has been modified more than once, copy the appropriate table below, as necessary, and complete the information for each additional modification.

<b><i>WPAP Modification</i></b>	<b><i>Approved Project</i></b>	<b><i>Proposed Modification</i></b>
<b><i>Summary</i></b>		
Acres	<u>12.72</u>	<u>12.72</u>
Type of Development	<u>Commerical</u>	<u>Commercial</u>
Number of Residential Lots	<u>N/A</u>	<u>N/A</u>
Impervious Cover (acres)	<u>9.51</u>	<u>8.58</u> (3.569 ac for Phase II)
Impervious Cover (%)	<u>74.8</u>	<u>67.5</u>
Permanent BMPs	<u>Sedimentation Basin;</u>	<u>Sedimentation Basin;</u>
Other	<u>15' VFS</u>	<u>15' VFS</u>

<b><i>SCS Modification</i></b>	<b><i>Approved Project</i></b>	<b><i>Proposed Modification</i></b>
<b><i>Summary</i></b>		
Linear Feet	_____	_____
Pipe Diameter	_____	_____
Other	_____	_____

<b><i>AST Modification</i></b>	<b><i>Approved Project</i></b>	<b><i>Proposed Modification</i></b>
<b><i>Summary</i></b>		
Number of ASTs	_____	_____
Volume of ASTs	_____	_____
Other	_____	_____

<b><i>UST Modification</i></b>	<b><i>Approved Project</i></b>	<b><i>Proposed Modification</i></b>
<b><i>Summary</i></b>		
Number of USTs	_____	_____
Volume of USTs	_____	_____
Other	_____	_____

5.  **Attachment B: Narrative of Proposed Modification.** A detailed narrative description of the nature of the proposed modification is attached. It discusses what was approved, including any previous modifications, and how this proposed modification will change the approved plan.
  
6.  **Attachment C: Current Site Plan of the Approved Project.** A current site plan showing the existing site development (i.e., current site layout) at the time this application for modification is attached. A site plan detailing the changes proposed in the submitted modification is required elsewhere.
  - The approved construction has not commenced. The original approval letter and any subsequent modification approval letters are included as Attachment A to document that the approval has not expired.
  - The approved construction has commenced and has been completed. Attachment C illustrates that the site was constructed as approved.
  - The approved construction has commenced and has been completed. Attachment C illustrates that the site was **not** constructed as approved.
  - The approved construction has commenced and has **not** been completed. Attachment C illustrates that, thus far, the site was constructed as approved.
  - The approved construction has commenced and has **not** been completed. Attachment C illustrates that, thus far, the site was **not** constructed as approved.
  
7.  The acreage of the approved plan has increased. A Geologic Assessment has been provided for the new acreage.
  - Acreage has not been added to or removed from the approved plan.
  
8.  Submit one (1) original and one (1) copy of the application, plus additional copies as needed for each affected incorporated city, groundwater conservation district, and county in which the project will be located. The TCEQ will distribute the additional copies to these jurisdictions. The copies must be submitted to the appropriate regional office.

**ATTACHMENT A**

Bryan W. Shaw, Ph.D., P.E., *Chairman*  
Toby Baker, *Commissioner*  
Jon Niermann, *Commissioner*  
Richard A. Hyde, P.E., *Executive Director*



## TEXAS COMMISSION ON ENVIRONMENTAL QUALITY

*Protecting Texas by Reducing and Preventing Pollution*

May 11, 2016

Mr. William T. Ellis  
Teralta Partners, Ltd.  
70 N.E. Loop 410, Suite 250  
San Antonio, Texas 78216

Re: Edwards Aquifer, Bexar County

NAME OF PROJECT: Teralta Corporate Park; Located on the northwest corner of the intersection of Loop 1604 Frontage Road and Lou Mell Drive; San Antonio, Texas

TYPE OF PLAN: Request for the Approval of a Water Pollution Abatement Plan (WPAP); 30 Texas Administrative Code (TAC) Chapter 213 Edwards Aquifer

Regulated Entity No. RN109119271; Additional ID No. 13000111

Dear Mr. Ellis:

The Texas Commission on Environmental Quality (TCEQ) has completed its review of the WPAP application for the above-referenced project submitted to the San Antonio Regional Office by Pape-Dawson Engineers, Inc. on behalf of Teralta Partners, Ltd. on March 4, 2016. Final review of the WPAP was completed after additional material was received on May 03, 2016. As presented to the TCEQ, the Temporary and Permanent Best Management Practices (BMPs) were selected and construction plans were prepared by a Texas Licensed Professional Engineer to be in general compliance with the requirements of 30 TAC Chapter 213. These planning materials were sealed, signed and dated by a Texas Licensed Professional Engineer. Therefore, based on the engineer's concurrence of compliance, the planning materials for construction of the proposed project and pollution abatement measures are hereby approved subject to applicable state rules and the conditions in this letter. The applicant or a person affected may file with the chief clerk a motion for reconsideration of the executive director's final action on this Edwards Aquifer Protection Plan. A motion for reconsideration must be filed no later than 23 days after the date of this approval letter. *This approval expires two (2) years from the date of this letter unless, prior to the expiration date, more than 10 percent of the construction has commenced on the project or an extension of time has been requested.*

### PROJECT DESCRIPTION

The proposed commercial project will have an area of approximately 12.72 acres. It will include the demolition of existing impervious cover (0.83 acres), clearing, grading, installation of utilities, drainage improvements, construction of commercial buildings, driveways, parking, and sidewalks. The impervious cover will be 9.51 acres (74.8 percent). Project wastewater will be disposed of by conveyance to the existing Dos Rios Water Recycling Center owned by San Antonio Water System.

### PERMANENT POLLUTION ABATEMENT MEASURES

To prevent the pollution of stormwater runoff originating on-site or upgradient of the site and potentially flowing across and off the site after construction, two engineered vegetative filter strips (VFS) and one single chamber sedimentation/filtration basin, designed using the TCEQ technical guidance document, Complying with the Edwards Aquifer Rules: Technical Guidance on Best Management Practices (2005), will be constructed to treat stormwater runoff. The required total suspended solids (TSS) treatment for this project is 7,083 pounds of TSS generated from the 9.51 acres of impervious cover. The approved measures meet the required 80 percent removal of the increased load in TSS caused by the project.

The single chamber sedimentation/filtration basin will have a 4 inch perforated PVC underdrain system that will be covered with a 6 inch gravel layer. Geotextile fabric will be placed over the gravel layer and topped with 18 inches of sand (ASTM C-33 compliant). The basin will have a clay or geomembrane liner that will conform to the design standards as listed in the application. The basin will have a designed water quality volume of 34,301 cubic feet (34,026 required) and a designed sand filter area of 3,469 square feet (3,403 required). This basin is designed to remove 6,520 pounds of TSS (6,438 pounds required) from the 8.72 acres of impervious cover being directed to it. This basin has been oversized to account for 0.10 acres of uncaptured impervious cover from watershed B.

The VFSs will be at least 15 feet wide (in the direction of flow), and will extend along the entire length of the contributing areas with no gullies, rills, or obstructions that will concentrate flow. The VFSs will have a uniform slope of less than 20 percent, and will maintain a vegetated cover of at least 80 percent. The VFS for drainage area C has been designed to remove 384 pounds of TSS annually. The VFS for drainage area D has been designed to remove 180 pounds of TSS annually.

### GEOLOGY

The proposed site is located partially within the Recharge Zone and the Contributing Zone within the Transition Zone. According to the geologic assessment included with the application, the site is located over the Buda Limestone and the cyclic and marine members of the Person Formation. The geologic assessment identified five man-made features in bedrock, four non-karst closed depressions, and three faults within the site boundaries. Five of the man-made features in bedrock (S-1, S-2, S-4, S-7, and S-12) were

rated as sensitive. The San Antonio Regional Office site assessment conducted on April 27, 2016 revealed the site was generally as described in the geologic assessment.

#### SPECIAL CONDITIONS

- I. Each permanent pollution abatement measures shall be operational prior to first occupancy of any facility within its drainage area.
- II. All sediment and/or media removed from the water quality basin during maintenance activities shall be properly disposed of according to 30 TAC 330 or 30 TAC 335, as applicable.

#### STANDARD CONDITIONS

1. Pursuant to Chapter 7 Subchapter C of the Texas Water Code, any violations of the requirements in 30 TAC Chapter 213 may result in administrative penalties.
2. The holder of the approved Edwards Aquifer protection plan must comply with all provisions of 30 TAC Chapter 213 and all best management practices and measures contained in the approved plan. Additional and separate approvals, permits, registrations and/or authorizations from other TCEQ Programs (i.e., Stormwater, Water Rights, UIC) can be required depending on the specifics of the plan.
3. In addition to the rules of the Commission, the applicant may also be required to comply with state and local ordinances and regulations providing for the protection of water quality.

#### Prior to Commencement of Construction:

4. Within 60 days of receiving written approval of an Edwards Aquifer Protection Plan, the applicant must submit to the San Antonio Regional Office, proof of recordation of notice in the county deed records, with the volume and page number(s) of the county deed records of the county in which the property is located. A description of the property boundaries shall be included in the deed recordation in the county deed records. A suggested form (Deed Recordation Affidavit, TCEQ-0625) that you may use to deed record the approved WPAP is enclosed.
5. All contractors conducting regulated activities at the referenced project location shall be provided a copy of this notice of approval. At least one complete copy of the approved WPAP and this notice of approval shall be maintained at the project location until all regulated activities are completed.
6. Modification to the activities described in the referenced WPAP application following the date of approval may require the submittal of a plan to modify this approval, including the payment of appropriate fees and all information necessary for its review and approval prior to initiating construction of the modifications.
7. The applicant must provide written notification of intent to commence construction, replacement, or rehabilitation of the referenced project. Notification must be submitted to the San Antonio Regional Office no later than 48 hours prior to commencement of the regulated activity. Written notification must include the

date on which the regulated activity will commence, the name of the approved plan and program ID number for the regulated activity, and the name of the prime contractor with the name and telephone number of the contact person. The executive director will use the notification to determine if the approved plan is eligible for an extension.

8. Temporary erosion and sedimentation (E&S) controls, i.e., silt fences, rock berms, stabilized construction entrances, or other controls described in the approved WPAP, must be installed prior to construction and maintained during construction. Temporary E&S controls may be removed when vegetation is established and the construction area is stabilized. If a water quality pond is proposed, it shall be used as a sedimentation basin during construction. The TCEQ may monitor stormwater discharges from the site to evaluate the adequacy of temporary E&S control measures. Additional controls may be necessary if excessive solids are being discharged from the site.
9. All borings with depths greater than or equal to 20 feet must be plugged with non-shrink grout from the bottom of the hole to within three (3) feet of the surface. The remainder of the hole must be backfilled with cuttings from the boring. All borings less than 20 feet must be backfilled with cuttings from the boring. All borings must be backfilled or plugged within four (4) days of completion of the drilling operation. Voids may be filled with gravel.

During Construction:

10. During the course of regulated activities related to this project, the applicant or agent shall comply with all applicable provisions of 30 TAC Chapter 213, Edwards Aquifer. The applicant shall remain responsible for the provisions and conditions of this approval until such responsibility is legally transferred to another person or entity.
11. This approval does not authorize the installation of temporary aboveground storage tanks on this project. If the contractor desires to install a temporary aboveground storage tank for use during construction, an application to modify this approval must be submitted and approved prior to installation. The application must include information related to tank location and spill containment. Refer to Standard Condition No. 6, above.
12. If any sensitive feature (caves, solution cavities, sink holes, etc.) is discovered during construction, all regulated activities near the feature must be suspended immediately. The applicant or his agent must immediately notify the San Antonio Regional Office of the discovery of the feature. Regulated activities near the feature may not proceed until the executive director has reviewed and approved the methods proposed to protect the feature and the aquifer from potentially adverse impacts to water quality. The plan must be sealed, signed, and dated by a Texas Licensed Professional Engineer.
13. One well exists on site. All water wells, including injection, dewatering, and monitoring wells must be in compliance with the requirements of the Texas Department of Licensing and Regulation under Title 16 TAC Chapter 76 (relating to

Water Well Drillers and Pump Installers) and all other locally applicable rules, as appropriate.

14. If sediment escapes the construction site, the sediment must be removed at a frequency sufficient to minimize offsite impacts to water quality (e.g., fugitive sediment in street being washed into surface streams or sensitive features by the next rain). Sediment must be removed from sediment traps or sedimentation ponds not later than when design capacity has been reduced by 50 percent. Litter, construction debris, and construction chemicals shall be prevented from becoming stormwater discharge pollutants.
15. Intentional discharges of sediment laden water are not allowed. If dewatering becomes necessary, the discharge will be filtered through appropriately selected best management practices. These may include vegetated filter strips, sediment traps, rock berms, silt fence rings, etc.
16. The following records shall be maintained and made available to the executive director upon request: the dates when major grading activities occur, the dates when construction activities temporarily or permanently cease on a portion of the site, and the dates when stabilization measures are initiated.
17. Stabilization measures shall be initiated as soon as practicable in portions of the site where construction activities have temporarily or permanently ceased, and construction activities will not resume within 21 days. When the initiation of stabilization measures by the 14th day is precluded by weather conditions, stabilization measures shall be initiated as soon as practicable.

After Completion of Construction:

18. A Texas Licensed Professional Engineer must certify in writing that the permanent BMPs or measures were constructed as designed. The certification letter must be submitted to the San Antonio Regional Office within 30 days of site completion.
19. The applicant shall be responsible for maintaining the permanent BMPs after construction until such time as the maintenance obligation is either assumed in writing by another entity having ownership or control of the property (such as without limitation, an owner's association, a new property owner or lessee, a district, or municipality) or the ownership of the property is transferred to the entity. The regulated entity shall then be responsible for maintenance until another entity assumes such obligations in writing or ownership is transferred. A copy of the transfer of responsibility must be filed with the executive director through San Antonio Regional Office within 30 days of the transfer. A copy of the transfer form (TCEQ-10263) is enclosed.
20. Upon legal transfer of this property, the new owner(s) is required to comply with all terms of the approved Edwards Aquifer protection plan. If the new owner intends to commence any new regulated activity on the site, a new Edwards Aquifer protection plan that specifically addresses the new activity must be submitted to the executive director. Approval of the plan for the new regulated activity by the executive director is required prior to commencement of the new regulated activity.

Mr. William T. Ellis  
Page 6  
May 11, 2016

21. An Edwards Aquifer protection plan approval or extension will expire and no extension will be granted if more than 50 percent of the total construction has not been completed within ten years from the initial approval of a plan. A new Edwards Aquifer protection plan must be submitted to the San Antonio Regional Office with the appropriate fees for review and approval by the executive director prior to commencing any additional regulated activities.
22. At project locations where construction is initiated and abandoned, or not completed, the site shall be returned to a condition such that the aquifer is protected from potential contamination.

This action is taken under authority delegated by the Executive Director of the Texas Commission on Environmental Quality. If you have any questions or require additional information, please contact Mr. Alex Grant of the Edwards Aquifer Protection Program of the San Antonio Regional Office at 210-403-4035.

Sincerely,



Lynn Bumguardner Water Section Manager  
San Antonio Region  
Texas Commission on Environmental Quality

LB/AG/eg

Enclosure: Deed Recordation Affidavit, Form TCEQ-0625  
Change in Responsibility for Maintenance of Permanent BMPs, Form  
TCEQ-10263

cc: Mr. Matt Johnson, P.E., Pape-Dawson Engineers, Inc.  
Mr. Roland Ruiz, Edwards Aquifer Authority  
Ms. Renee Green, P.E., Bexar County Public Works  
Mr. George Wissmann, Trinity Glen Rose GCD  
Mr. Scott Halty, San Antonio Water System  
TCEQ Central Records, Building F, MC 21

**ATTACHMENT B**

## TERALTA PHASE II Water Pollution Abatement Plan Modification

### Attachment B – Narrative of Proposed Modification

Teralta Phase II Water Pollution Abatement Plan (WPAP) is a modification of the previously approved Teralta Corporate Park (ID 13000111), which approved a commercial development on an approximately 12.72-acre legal limit with 9.51 acres of impervious cover. This Teralta Phase II proposes the second phase of this development, with additional buildings, parking and drives on a project site of 6.23 acres. The site is located at 4949 N Loop 1604 W, San Antonio, Texas, and is over both the Edwards Aquifer Recharge Zone and Contributing Zone within the Transition Zone. There are five (5) manmade sensitive geologic features and no naturally occurring sensitive features as identified by the Geologic Assessment.

This WPAP proposes additional clearing, grading, excavation, installation of utilities and drainage improvements for the construction of three (3) commercial buildings with associated parking and drives. An inlet with a headwall and splashpad are proposed to route the stormwater for this phase to the existing sedimentation basin. The location of the gate on the basin is proposed to be relocated, but no other modifications to the basin are proposed. These proposed improvements will add 3.569 acres of impervious cover to the existing 5.011 acres of impervious cover from the first phase of development. The total impervious cover for this 12.72-acre legal limit site is 8.58 acres, or 67.5% of the overall development. The proposed Permanent Best Management Practices (PBMPs) for stormwater treatment are one (1) existing, approved sedimentation basin (ID 13000111) and one (1) existing, approved fifteen-foot (15') engineered vegetative filter strip (ID 13000111), which were designed in accordance with the TCEQ's Technical Guidance Manual (TGM) RG-348 (2005) to remove 80% of the increase in Total Suspended Solids (TSS) from the site. The previously approved VFS "D" (ID 13000111) is proposed to be removed and treatment for this area is now provided by the existing sedimentation basin, which has been sized accordingly. In Watershed "B," approximately 0.10 acres of impervious cover from the proposed driveway will be treated via overtreatment from the existing basin. Please see the Treatment Summary table attached with this application.

The Teralta Phase II Sewage Collection System (SCS) application proposes the construction of a total of approximately 157 linear feet (LF) of sanitary sewer main to serve the commercial development. Regulated activities proposed include excavation, installation of sewer mains and manholes, backfill, and compaction. Approximately 0.36 acres may be disturbed as identified by the 50-foot envelope shown on the plans; however, an overall 6.23 acres may be disturbed for this phase of development.

Potable water service is to be provided by the San Antonio Water System (SAWS). The proposed development will generate approximately 13,200 gallons per day (average flow) of domestic wastewater based on the assumption of 200 gpd per EDU ( $66 \text{ EDU} * 200 \text{ gpd/EDU} = 13,200 \text{ gpd}$ ). Wastewater will be disposed of by conveyance to the existing Steven M. Clouse Water Recycling Center operated by SAWS.

# **ATTACHMENT C**

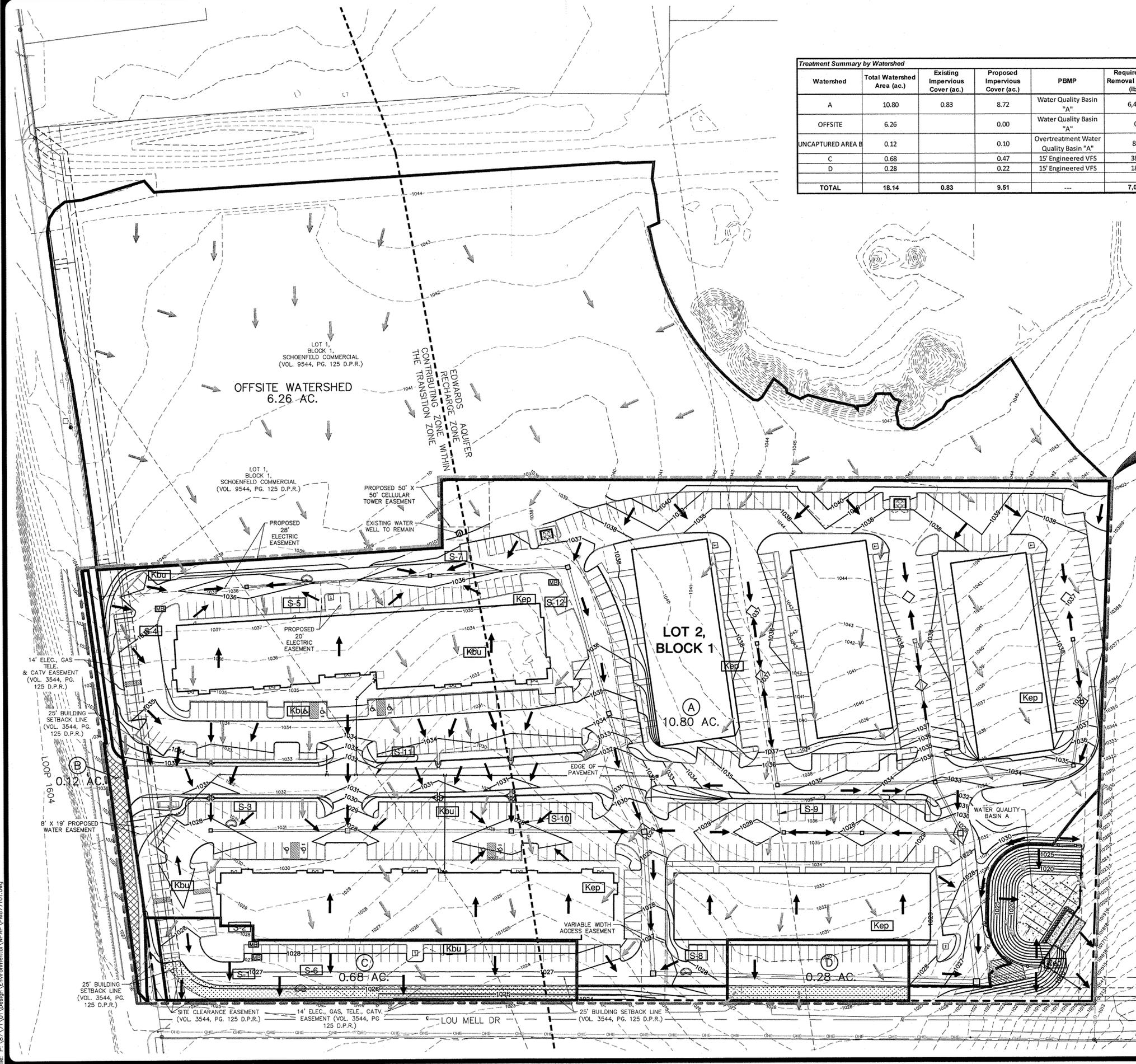

Treatment Summary by Watershed						
Watershed	Total Watershed Area (ac.)	Existing Impervious Cover (ac.)	Proposed Impervious Cover (ac.)	PBMP	Required TSS Removal Annually (lbs)	TSS Removed Annually (lbs)
A	10.80	0.83	8.72	Water Quality Basin "A"	6,438	6,520
OFFSITE	6.26		0.00	Water Quality Basin "A"	0	0
UNCAPTURED AREA B	0.12		0.10	Overtreatment Water Quality Basin "A"	82	N/A
C	0.68		0.47	15' Engineered VFS	384	384
D	0.28		0.22	15' Engineered VFS	180	180
<b>TOTAL</b>	<b>18.14</b>	<b>0.83</b>	<b>9.51</b>		<b>7,083</b>	<b>7,083</b>



LOCATION MAP  
NOT-TO-SCALE

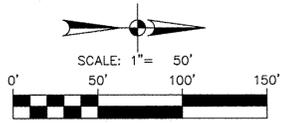

PROJECT LIMITS  
(12.72 ACRES)

**SUMMARY OF PERMANENT POLLUTION ABATEMENT MEASURES:**

- TEMPORARY BMP'S WILL BE MAINTAINED UNTIL THE SITE IMPROVEMENTS ARE COMPLETED AND THE SITE HAS BEEN STABILIZED, INCLUDING SUFFICIENT VEGETATION BEING ESTABLISHED.
- DURING CONSTRUCTION, TO THE EXTENT PRACTICAL, CONTRACTOR SHALL MINIMIZE THE AREA OF SOIL DISTURBANCE. AREAS OF DISTURBED SOIL SHALL BE REVEGETATED TO STABILIZE SOIL USING SOLID SOD IN A STAGGERED PATTERN. SEE DETAIL ON EXHIBIT 4 AND REFER TO SECTION 1.3.11 IN TCEQ'S TECHNICAL GUIDANCE MANUAL RG-348 (2005). SOD SHOULD BE USED IN CHANNELS AND ON SLOPES > 15%. THE CONTRACTOR MAY SUBSTITUTE THE USE OF SOD WITH THE PLACEMENT OF TOP SOIL AND A FRILABLE SEED BED WITH A PROTECTIVE MATTING OR HYDRAULIC MULCH ALONG WITH WATERING UNTIL VEGETATION IS ESTABLISHED. APPLICATIONS AND PRODUCTS SHALL BE THOSE APPROVED BY TxDOT AS OF FEBRUARY 2001 AND IN COMPLIANCE WITH THE TGM RG-348 (2005). SEED MIXTURE AND/OR GRASS TYPE TO BE DETERMINED BY OWNER AND SHOULD BE IN COMPLIANCE WITH TGM RG-348 (2005) GUIDELINES. IRRIGATION MAY BE REQUIRED IN ORDER TO ESTABLISH SUFFICIENT VEGETATION.
- FOR DISTURBED AREAS WHERE INSUFFICIENT SOIL EXISTS TO ESTABLISH VEGETATION, CONTRACTOR SHALL PLACE A MINIMUM OF 6" OF TOPSOIL PRIOR TO REVEGETATION.
- PERMANENT BMP'S FOR THIS SITE INCLUDE A SAND FILTER BASIN AND TWO (2) ENGINEERED VEGETATIVE FILTER STRIPS. THESE PERMANENT BMP'S HAVE BEEN DESIGNED TO REMOVE AT LEAST 80% OF THE INCREASED TOTAL SUSPENDED SOLIDS (TSS) IN ACCORDANCE WITH THE TCEQ'S TECHNICAL GUIDANCE MANUAL (TGM) RG-348 (2005).
- TYPICAL SLOPES ON THIS PROJECT RANGE FROM APPROXIMATELY 1.0% TO 10.0%.
- SILT FENCING AND ROCK BERMS, WHERE APPROPRIATE, WILL BE MAINTAINED UNTIL THE ROADWAY, UTILITY, DRAINAGE IMPROVEMENTS, AND BUILDING CONSTRUCTION ARE COMPLETED.
- CONTRACTOR SHALL INSTALL AND ESTABLISH VEGETATION FOR SOIL STABILIZATION PRIOR TO SITE CLOSEOUT.
- ALL PERMANENT BMP'S MUST BE CERTIFIED BY A REGISTERED PROFESSIONAL ENGINEER.

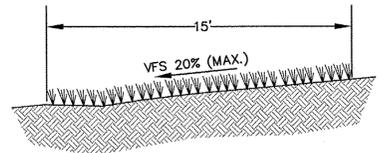

ENGINEERED VEGETATIVE FILTER STRIP DETAIL  
NOT-TO-SCALE

THE ENGINEERING SEAL HAS BEEN AFFIXED TO THIS SHEET ONLY FOR THE PURPOSE OF DEMONSTRATING COMPLIANCE WITH THE POLLUTION ABATEMENT SIZING AND TREATMENT REQUIREMENTS OF THE TEXAS COMMISSION ON ENVIRONMENTAL QUALITY'S EDWARDS AQUIFER TECHNICAL GUIDANCE MANUAL.

THIS SHEET HAS BEEN PREPARED FOR PURPOSES OF POLLUTION ABATEMENT ONLY. ALL OTHER CIVIL ENGINEERING RELATED INFORMATION SHOULD BE ACQUIRED FROM THE APPROPRIATE SHEET IN THE CIVIL IMPROVEMENT PLANS.

EXHIBIT 5

NO.	REVISION	DATE



**PAPE-DAWSON ENGINEERS**  
 SAN ANTONIO, TEXAS 78213 | PHONE: 210.375.9000 | FAX: 210.375.9070  
 TEXAS BOARD OF PROFESSIONAL ENGINEERS, FIRM REGISTRATION # 470  
 TEXAS BOARD OF PROFESSIONAL LAND SURVEYING, FIRM REGISTRATION # 10228600

**TERALTA CORPORATE PARK**  
 SAN ANTONIO, TEXAS  
 WATER POLLUTION ABATEMENT PLAN  
 PERMANENT POLLUTION ABATEMENT PLAN

PLAT NO.	N/A
JOB NO.	8771-01
DATE	FEB 2016
DESIGNER	MG
CHECKED	LM, DRAWN MG
SHEET	C10.20

**WATER POLLUTION  
ABATEMENT PLAN  
APPLICATION FORM (TCEQ-  
0584)**

# Water Pollution Abatement Plan Application

## Texas Commission on Environmental Quality

for Regulated Activities on the Edwards Aquifer Recharge Zone and Relating to 30 TAC §213.5(b), Effective June 1, 1999

*To ensure that the application is administratively complete, confirm that all fields in the form are complete, verify that all requested information is provided, consistently reference the same site and contact person in all forms in the application, and ensure forms are signed by the appropriate party.*

*Note: Including all the information requested in the form and attachments contributes to more streamlined technical reviews.*

## Signature

To the best of my knowledge, the responses to this form accurately reflect all information requested concerning the proposed regulated activities and methods to protect the Edwards Aquifer. This **Water Pollution Abatement Plan Application Form** is hereby submitted for TCEQ review and Executive Director approval. The form was prepared by:

Print Name of Customer/Agent: Andrew Belton, P.E.

Date: 4/10/24

Signature of Customer/Agent:



Regulated Entity Name: Teralta Phase II

## Regulated Entity Information

- The type of project is:
  - Residential: Number of Lots: \_\_\_\_\_
  - Residential: Number of Living Unit Equivalents: \_\_\_\_\_
  - Commercial
  - Industrial
  - Other: \_\_\_\_\_
- Total site acreage (size of property): 12.72
- Estimated projected population: N/A
- The amount and type of impervious cover expected after construction are shown below:

**Table 1 - Impervious Cover Table**

Impervious Cover of Proposed Project	Sq. Ft.	Sq. Ft./Acre	Acres
Structures/Rooftops	125,740	÷ 43,560 =	2.89
Parking	243,285	÷ 43,560 =	5.58
Other paved surfaces	4,720	÷ 43,560 =	0.11
Total Impervious Cover	373,745	÷ 43,560 =	8.58

**Total Impervious Cover 8.58 ÷ Total Acreage 12.72 X 100 = 67.5% Impervious Cover**

Phase II Impervious Cover 3,569 Total Acreage 6.23 X 100 = 57.3% Impervious Cover

5.  **Attachment A - Factors Affecting Surface Water Quality.** A detailed description of all factors that could affect surface water and groundwater quality that addresses ultimate land use is attached.
6.  Only inert materials as defined by 30 TAC §330.2 will be used as fill material.

***For Road Projects Only***

**Complete questions 7 - 12 if this application is exclusively for a road project.**

7. Type of project:

- TXDOT road project.
- County road or roads built to county specifications.
- City thoroughfare or roads to be dedicated to a municipality.
- Street or road providing access to private driveways.

8. Type of pavement or road surface to be used:

- Concrete
- Asphaltic concrete pavement
- Other: \_\_\_\_\_

9. Length of Right of Way (R.O.W.): \_\_\_\_\_ feet.

Width of R.O.W.: \_\_\_\_\_ feet.

L x W = \_\_\_\_\_ Ft<sup>2</sup> ÷ 43,560 Ft<sup>2</sup>/Acre = \_\_\_\_\_ acres.

10. Length of pavement area: \_\_\_\_\_ feet.

Width of pavement area: \_\_\_\_\_ feet.

L x W = \_\_\_\_\_ Ft<sup>2</sup> ÷ 43,560 Ft<sup>2</sup>/Acre = \_\_\_\_\_ acres.

Pavement area \_\_\_\_\_ acres ÷ R.O.W. area \_\_\_\_\_ acres x 100 = \_\_\_\_\_% impervious cover.

11.  A rest stop will be included in this project.
- A rest stop will not be included in this project.

The sewage collection system will convey the wastewater to the Steven M. Clouse (name) Treatment Plant. The treatment facility is:

Existing.

Proposed.

16.  All private service laterals will be inspected as required in 30 TAC §213.5.

## **Site Plan Requirements**

**Items 17 – 28 must be included on the Site Plan.**

17.  The Site Plan must have a minimum scale of 1" = 400'.

Site Plan Scale: 1" = 50'.

18. 100-year floodplain boundaries:

Some part(s) of the project site is located within the 100-year floodplain. The floodplain is shown and labeled.

No part of the project site is located within the 100-year floodplain.

The 100-year floodplain boundaries are based on the following specific (including date of material) sources(s): DFIRM (Digital Flood Insurance Rate Map for Bexar County, Texas and Incorporated Areas) Panel No. 48029C0230G, Dated 09/29/2010

19.  The layout of the development is shown with existing and finished contours at appropriate, but not greater than ten-foot contour intervals. Lots, recreation centers, buildings, roads, open space, etc. are shown on the plan.

The layout of the development is shown with existing contours at appropriate, but not greater than ten-foot intervals. Finished topographic contours will not differ from the existing topographic configuration and are not shown. Lots, recreation centers, buildings, roads, open space, etc. are shown on the site plan.

20. All known wells (oil, water, unplugged, capped and/or abandoned, test holes, etc.):

There are 1 (#) wells present on the project site and the locations are shown and labeled. (Check all of the following that apply)

The wells are not in use and have been properly abandoned.

The wells are not in use and will be properly abandoned.

The wells are in use and comply with 16 TAC §76.

There are no wells or test holes of any kind known to exist on the project site.

21. Geologic or manmade features which are on the site:

All sensitive geologic or manmade features identified in the Geologic Assessment are shown and labeled.

No sensitive geologic or manmade features were identified in the Geologic Assessment.

- Attachment D - Exception to the Required Geologic Assessment.** A request and justification for an exception to a portion of the Geologic Assessment is attached.
22.  The drainage patterns and approximate slopes anticipated after major grading activities.
23.  Areas of soil disturbance and areas which will not be disturbed.
24.  Locations of major structural and nonstructural controls. These are the temporary and permanent best management practices.
25.  Locations where soil stabilization practices are expected to occur.
26.  Surface waters (including wetlands).  
 N/A
27.  Locations where stormwater discharges to surface water or sensitive features are to occur.  
 There will be no discharges to surface water or sensitive features.
28.  Legal boundaries of the site are shown.

### ***Administrative Information***

29.  Submit one (1) original and one (1) copy of the application, plus additional copies as needed for each affected incorporated city, groundwater conservation district, and county in which the project will be located. The TCEQ will distribute the additional copies to these jurisdictions. The copies must be submitted to the appropriate regional office.
30.  Any modification of this WPAP will require Executive Director approval, prior to construction, and may require submission of a revised application, with appropriate fees.

- Attachment D - Exception to the Required Geologic Assessment.** A request and justification for an exception to a portion of the Geologic Assessment is attached.
22.  The drainage patterns and approximate slopes anticipated after major grading activities.
23.  Areas of soil disturbance and areas which will not be disturbed.
24.  Locations of major structural and nonstructural controls. These are the temporary and permanent best management practices.
25.  Locations where soil stabilization practices are expected to occur.
26.  Surface waters (including wetlands).  
 N/A
27.  Locations where stormwater discharges to surface water or sensitive features are to occur.  
 There will be no discharges to surface water or sensitive features.
28.  Legal boundaries of the site are shown.

### ***Administrative Information***

29.  Submit one (1) original and one (1) copy of the application, plus additional copies as needed for each affected incorporated city, groundwater conservation district, and county in which the project will be located. The TCEQ will distribute the additional copies to these jurisdictions. The copies must be submitted to the appropriate regional office.
30.  Any modification of this WPAP will require Executive Director approval, prior to construction, and may require submission of a revised application, with appropriate fees.

**ATTACHMENT A**

## TERALTA PHASE II

### Water Pollution Abatement Plan Modification

#### Attachment A – Factors Affecting Water Quality

Potential sources of pollution that may reasonably be expected to affect the quality of storm water discharges from the site during construction include:

- Soil erosion due to the clearing of the site;
- Oil, grease, fuel and hydraulic fluid contamination from construction equipment and vehicle drippings;
- Hydrocarbons from asphalt paving operations;
- Miscellaneous trash and litter from construction workers and material wrappings;
- Concrete truck washout.
- Potential overflow/spills from portable toilets

Potential sources of pollution that may reasonably be expected to affect the quality of storm water discharges from the site after development include:

- Oil, grease, fuel and hydraulic fluid contamination from vehicle drippings;
- Dirt and dust which may fall off vehicles; and
- Miscellaneous trash and litter.

**ATTACHMENT B**

## TERALTA PHASE II

### Water Pollution Abatement Plan Modification

#### Attachment B – Volume and Character of Stormwater

Stormwater runoff will increase as a result of this development. For a 25-year storm event, the overall project will generate approximately 117 cfs. The runoff coefficient for the site changes from approximately 0.60 before development to 0.77 after development. Values are based on the Rational Method using runoff coefficients per the City of San Antonio Unified Development Code.

**ORGANIZED SEWAGE  
COLLECTION SYSTEM PLAN  
(TCEQ-0582)**

# Organized Sewage Collection System Application

## Texas Commission on Environmental Quality

For Regulated Activities on the Edwards Aquifer Recharge Zone and Relating to 30 TAC §213.5(c), Effective June 1, 1999

**To ensure that the application is administratively complete, confirm that all fields in the form are complete, verify that all requested information is provided, consistently reference the same site and contact person in all forms in the application, and ensure forms are signed by the appropriate party.**

**Note: Including all the information requested in the form and attachments contributes to more streamlined technical reviews.**

**Regulated Entity Name:** Teralta Phase II

- Attachment A – SCS Engineering Design Report.** This Engineering Design Report is provided to fulfill the requirements of 30 TAC Chapter 217, including 217.10 of Subchapter A, §§217.51 – 217.70 of Subchapter C, and Subchapter D as applicable, and is required to be submitted with this SCS Application Form.

## Customer Information

- The entity and contact person responsible for providing the required engineering certification of testing for this sewage collection system upon completion (including private service connections) and every five years thereafter to the appropriate TCEQ region office pursuant to 30 TAC §213.5(c) is:

Contact Person: Jeff Brown

Entity: San Antonio Water System

Mailing Address: 2800 US HWY 281

City, State: San Antonio, Texas

Zip: 78212

Telephone: (210) 233-3605

Fax: (210) 233-4966

Email Address: \_\_\_\_\_

**The appropriate regional office must be informed of any changes in this information within 30 days of the change.**

- The engineer responsible for the design of this sewage collection system is:

Contact Person: Andrew Belton, P.E.

Texas Licensed Professional Engineer's Number: 121688

Entity: Pape-Dawson Consulting Engineers, LLC

Mailing Address: 2000 NW Loop 410

City, State: San Antonio, Texas

Zip: 78213

Telephone: (210) 375-9000

Fax: (210) 375-9010

Email Address: abelton@pape-dawson.com

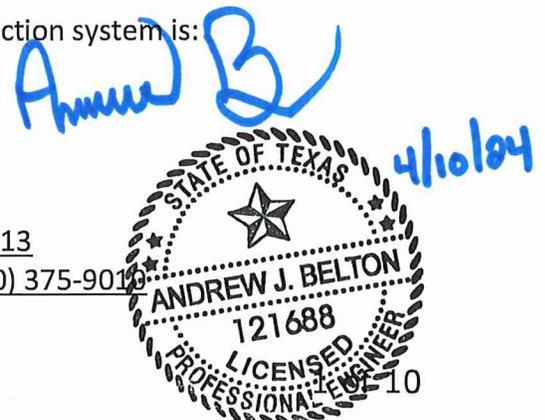

## Project Information

4. Anticipated type of development to be served (estimated future population to be served, plus adequate allowance for institutional and commercial flows):

- Residential: Number of single-family lots: \_\_\_\_\_  
 Multi-family: Number of residential units: \_\_\_\_\_  
 Commercial  
 Industrial  
 Off-site system (not associated with any development)  
 Other: \_\_\_\_\_

5. The character and volume of wastewater is shown below:

100% Domestic 13,200 gallons/day  
 \_\_\_\_\_% Industrial \_\_\_\_\_ gallons/day  
 \_\_\_\_\_% Commingled \_\_\_\_\_ gallons/day  
 Total gallons/day: 13,200 (66 EDU \* 200 gpd/EDU)

6. Existing and anticipated infiltration/inflow is 600 gallons/day. This will be addressed by: proper sizing of the sewer main.

7. A Water Pollution Abatement Plan (WPAP) is required for construction of any associated commercial, industrial or residential project located on the Recharge Zone.

- The WPAP application for this development was approved by letter dated \_\_\_\_\_. A copy of the approval letter is attached.  
 The WPAP application for this development was submitted to the TCEQ on concurrent, but has not been approved.  
 A WPAP application is required for an associated project, but it has not been submitted.  
 There is no associated project requiring a WPAP application.

8. Pipe description:

**Table 1 - Pipe Description**

<i>Pipe Diameter(Inches)</i>	<i>Linear Feet (1)</i>	<i>Pipe Material (2)</i>	<i>Specifications (3)</i>
8" (NR)	135	PVC, SDR 26	ASTM D3034, ASTM D3212
8" (PR)	22	PVC, SDR 26	ASTM D2241, Class 160 ASTM D3139, ASTM C1173

**Total Linear Feet: 157**

- (1) Linear feet - Include stub-outs and double service connections. Do not include private service laterals.
  - (2) Pipe Material - If PVC, state SDR value.
  - (3) Specifications - ASTM / ANSI / AWWA specification and class numbers should be included.
9. The sewage collection system will convey the wastewater to the Steven M. Clouse (name) Treatment Plant. The treatment facility is:

- Existing
- Proposed

10. All components of this sewage collection system will comply with:

- The City of San Antonio standard specifications.
- Other. Specifications are attached.

11.  No force main(s) and/or lift station(s) are associated with this sewage collection system.
- A force main(s) and/or lift station(s) is associated with this sewage collection system and the **Lift Station/Force Main System Application** form (TCEQ-0624) is included with this application.

***Alignment***

12.  There are no deviations from uniform grade in this sewage collection system without manholes and with open cut construction.
13.  There are no deviations from straight alignment in this sewage collection system without manholes.
- Attachment B - Justification and Calculations for Deviation in Straight Alignment without Manholes.** A justification for deviations from straight alignment in this sewage collection system without manholes with documentation from pipe manufacturer allowing pipe curvature is attached.
- For curved sewer lines, all curved sewer line notes (TCEQ-0596) are included on the construction plans for the wastewater collection system.

***Manholes and Cleanouts***

14.  Manholes or clean-outs exist at the end of each sewer line(s). These locations are listed below: (Please attach additional sheet if necessary)

**Table 2 - Manholes and Cleanouts**

<i>Line</i>	<i>Shown on Sheet</i>	<i>Station</i>	<i>Manhole or Clean-out?</i>
A	C6.20 Of	0+00.00	MH A-1
A	C6.20 Of	1+56.97	MH EXIST
	Of		
	Of		

<i>Line</i>	<i>Shown on Sheet</i>	<i>Station</i>	<i>Manhole or Clean-out?</i>
	Of		
	Of		
	Of		
	Of		
	Of		
	Of		

15.  Manholes are installed at all Points of Curvature and Points of Termination of a sewer line.
16.  The maximum spacing between manholes on this project for each pipe diameter is no greater than:

<b>Pipe Diameter (inches)</b>	<b>Max. Manhole Spacing (feet)</b>
6 - 15	500
16 - 30	800
36 - 48	1000
≥54	2000

- Attachment C – Justification for Variance from Maximum Manhole Spacing.** The maximum spacing between manholes on this project (for each pipe diameter used) is greater than listed in the table above. A justification for any variance from the maximum spacing is attached, and must include a letter from the entity which will operate and maintain the system stating that it has the capability to maintain lines with manhole spacing greater than the allowed spacing.
17.  All manholes will be monolithic, cast-in-place concrete.
- The use of pre-cast manholes is requested for this project. The manufacturer's specifications and construction drawings, showing the method of sealing the joints, are attached.

## **Site Plan Requirements**

**Items 18 - 25 must be included on the Site Plan.**

18.  The Site Plan must have a minimum scale of 1" = 400'.  
Site Plan Scale: 1" = 20'.
19.  The Site Plan must include the sewage collection system general layout, including manholes with station numbers, and sewer pipe stub outs (if any). Site plan must be overlain by topographic contour lines, using a contour interval of not greater than ten feet and showing the area within both the five-year floodplain and the 100-year floodplain of any drainage way.

20. Lateral stub-outs:

- The location of all lateral stub-outs are shown and labeled.
- No lateral stub-outs will be installed during the construction of this sewer collection system.

21. Location of existing and proposed water lines:

- The entire water distribution system for this project is shown and labeled.
- If not shown on the Site Plan, a Utility Plan is provided showing the entire water and sewer systems.
- There will be no water lines associated with this project.

22. 100-year floodplain:

- After construction is complete, no part of this project will be in or cross a 100-year floodplain, either naturally occurring or manmade. (Do not include streets or concrete-lined channels constructed above of sewer lines.)
- After construction is complete, all sections located within the 100-year floodplain will have water-tight manholes. These locations are listed in the table below and are shown and labeled on the Site Plan. (Do not include streets or concrete-lined channels constructed above sewer lines.)

**Table 3 - 100-Year Floodplain**

<i>Line</i>	<i>Sheet</i>	<i>Station</i>
N/A	of	to
	of	to
	of	to
	of	to

23. 5-year floodplain:

- After construction is complete, no part of this project will be in or cross a 5-year floodplain, either naturally occurring or man-made. (Do not include streets or concrete-lined channels constructed above sewer lines.)
- After construction is complete, all sections located within the 5-year floodplain will be encased in concrete or capped with concrete. These locations are listed in the table below and are shown and labeled on the Site Plan. (Do not include streets or concrete-lined channels constructed above sewer lines.)

**Table 4 - 5-Year Floodplain**

<i>Line</i>	<i>Sheet</i>	<i>Station</i>
N/A	of	to
	of	to
	of	to
	of	to

24.  Legal boundaries of the site are shown.
25.  The **final plans and technical specifications** are submitted for the TCEQ's review. Each sheet of the construction plans and specifications are dated, signed, and sealed by the Texas Licensed Professional Engineer responsible for the design on each sheet.

**Items 26 - 33 must be included on the Plan and Profile sheets.**

26.  All existing or proposed water line crossings and any parallel water lines within 9 feet of sewer lines are listed in the table below. These lines must have the type of pressure rated pipe to be installed shown on the plan and profile sheets. Any request for a variance from the required pressure rated piping at crossings must include a variance approval from 30 TAC Chapter 290.
- There will be no water line crossings.
- There will be no water lines within 9 feet of proposed sewer lines.

**Table 5 - Water Line Crossings**

<i>Line</i>	<i>Station or Closest Point</i>	<i>Crossing or Parallel</i>	<i>Horizontal Separation Distance</i>	<i>Vertical Separation Distance</i>
A	0+84.49	Crossing	-	5.10'
A	0+86.77	Crossing	-	5.80'

27. Vented Manholes:

- No part** of this sewer line is within the 100-year floodplain and vented manholes are not required by 30 TAC Chapter 217.
- A portion** of this sewer line is within the 100-year floodplain and vented manholes will be provided at less than 1500 foot intervals. These water-tight manholes are listed in the table below and labeled on the appropriate profile sheets.
- A portion** of this sewer line is within the 100-year floodplain and an alternative means of venting shall be provided at less than 1500 feet intervals. A description of the alternative means is described on the following page.
- A portion** of this sewer line is within the 100-year floodplain; however, there is no interval longer than 1500 feet located within. No vented manholes will be used.

**Table 6 - Vented Manholes**

<i>Line</i>	<i>Manhole</i>	<i>Station</i>	<i>Sheet</i>
N/A			

<i>Line</i>	<i>Manhole</i>	<i>Station</i>	<i>Sheet</i>

28. Drop manholes:

- There are no drop manholes associated with this project.
- Sewer lines which enter new or existing manholes or "manhole structures" higher than 24 inches above the manhole invert are listed in the table below and labeled on the appropriate profile sheets. These lines meet the requirements of 30 TAC §217.55(I)(2)(H).

**Table 7 - Drop Manholes**

<i>Line</i>	<i>Manhole</i>	<i>Station</i>	<i>Sheet</i>
N/A			

29. Sewer line stub-outs (For proposed extensions):

- The placement and markings of all sewer line stub-outs are shown and labeled.
- No sewer line stub-outs are to be installed during the construction of this sewage collection system.

30. Lateral stub-outs (For proposed private service connections):

- The placement and markings of all lateral stub-outs are shown and labeled.
- No lateral stub-outs are to be installed during the construction of this sewage collection system.

31. Minimum flow velocity (From Appendix A)

- Assuming pipes are flowing full; all slopes are designed to produce flows equal to or greater than 2.0 feet per second for this system/line.

32. Maximum flow velocity/slopes (From Appendix A)

- Assuming pipes are flowing full, all slopes are designed to produce maximum flows of less than or equal to 10 feet per second for this system/line.

- Attachment D – Calculations for Slopes for Flows Greater Than 10.0 Feet per Second.**  
Assuming pipes are flowing full, some slopes produce flows which are greater than 10 feet per second. These locations are listed in the table below. Calculations are attached.

**Table 8 - Flows Greater Than 10 Feet per Second**

<i>Line</i>	<i>Profile Sheet</i>	<i>Station to Station</i>	<i>FPS</i>	<i>% Slope</i>	<i>Erosion/Shock Protection</i>
N/A					

33. Assuming pipes are flowing full, where flows are  $\geq 10$  feet per second, the provisions noted below have been made to protect against pipe displacement by erosion and/or shock under 30 TAC §217.53(l)(2)(B).

- Concrete encasement shown on appropriate Plan and Profile sheets for the locations listed in the table above.
- Steel-reinforced, anchored concrete baffles/retards placed every 50 feet shown on appropriate Plan and Profile sheets for the locations listed in the table above.
- N/A

### ***Administrative Information***

34.  The final plans and technical specifications are submitted for TCEQ review. Each sheet of the construction plans and specifications are dated, signed, and sealed by the Texas Licensed Professional Engineer responsible for the design on each sheet.
35.  Standard details are shown on the detail sheets, which are dated, signed, and sealed by the Texas Licensed Professional Engineer, as listed in the table below:

**Table 9 - Standard Details**

<b><i>Standard Details</i></b>	<b><i>Shown on Sheet</i></b>
Lateral stub-out marking <b>[Required]</b>	C6.20 of
Manhole, showing inverts comply with 30 TAC §217.55(l)(2) <b>[Required]</b>	C6.20 of
Alternate method of joining lateral to existing SCS line for potential future connections <b>[Required]</b>	of
Typical trench cross-sections <b>[Required]</b>	C6.10 of
Bolted manholes <b>[Required]</b>	C6.10 of
Sewer Service lateral standard details <b>[Required]</b>	C6.10 of
Clean-out at end of line <b>[Required, if used]</b>	of
Baffles or concrete encasement for shock/erosion protection <b>[Required, if flow velocity of any section of pipe &gt;10 fps]</b>	of

<b>Standard Details</b>	<b>Shown on Sheet</b>
Detail showing Wastewater Line/Water Line Crossing [ <b>Required, if crossings are proposed</b> ]	C6.10 of
Mandrel detail or specifications showing compliance with 30 TAC §217.57(b) and (c) [ <b>Required, if Flexible Pipe is used</b> ]	of
Drop manholes [ <b>Required, if a pipe entering a manhole is more than 24 inches above manhole invert</b> ]	of

36.  All organized sewage collection system general construction notes (TCEQ-0596) are included on the construction plans for this sewage collection system.
37.  All proposed sewer lines will be sufficiently surveyed/staked to allow an assessment prior to TCEQ executive director approval. If the alignments of the proposed sewer lines are not walkable on that date, the application will be deemed incomplete and returned.
- Survey staking was completed on this date: when advised
38.  Submit one (1) original and one (1) copy of the application, plus additional copies as needed for each affected incorporated city, groundwater conservation district, and county in which the project will be located. The TCEQ will distribute the additional copies to these jurisdictions. The copies must be submitted to the appropriate regional office.
39.  Any modification of this SCS application will require TCEQ approval, prior to construction, and may require submission of a revised application, with appropriate fees.

## **Signature**

To the best of my knowledge, the responses to this form accurately reflect all information requested concerning the proposed regulated activities and methods to protect the Edwards Aquifer. This **Organized Sewage Collection System Application** is hereby submitted for TCEQ review and executive director approval. The system was designed in accordance with the requirements of 30 TAC §213.5(c) and 30 TAC §217 and prepared by:

Print Name of Licensed Professional Engineer: Andrew Belton, P.E.

Date: \_\_\_\_\_

Place engineer's seal here:

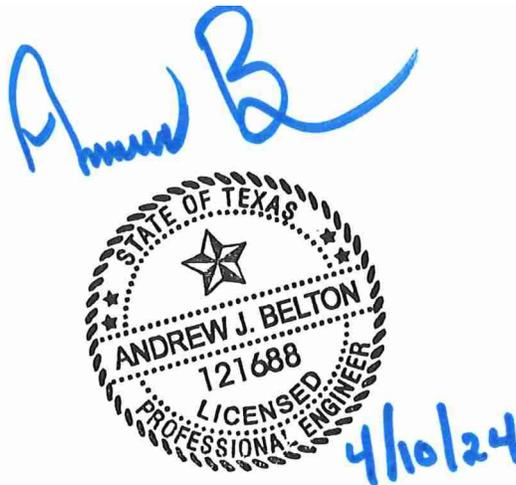

Signature of Licensed Professional Engineer:

---

## **Appendix A-Flow Velocity Table**

**Flow Velocity (Flowing Full)** All gravity sewer lines on the Edwards Aquifer Recharge Zone shall be designed and constructed with hydraulic slopes sufficient to give a velocity when flowing full of not less than 2.0 feet per second, and not greater than 10 feet per second. The grades shown in the following table are based on Manning's formula and an n factor of 0.013 and shall be the minimum and maximum acceptable slopes unless provisions are made otherwise.

**Table 10 - Slope Velocity**

<b><i>Pipe Diameter(Inches)</i></b>	<b><i>% Slope required for minimum flow velocity of 2.0 fps</i></b>	<b><i>% Slope which produces flow velocity of 10.0 fps</i></b>
6	0.50	12.35
8	0.33	8.40
10	0.25	6.23
12	0.20	4.88
15	0.15	3.62
18	0.11	2.83
21	0.09	2.30
24	0.08	1.93
27	0.06	1.65
30	0.055	1.43
33	0.05	1.26
36	0.045	1.12
39	0.04	1.01
>39	*	*

*\*For lines larger than 39 inches in diameter, the slope may be determined by Manning's formula (as shown below) to maintain a minimum velocity greater than 2.0 feet per second when flowing full and a maximum velocity less than 10 feet per second when flowing full.*

$$v = \frac{1.49}{n} \times R_h^{0.67} \times \sqrt{S}$$

**Figure 1 - Manning's Formula**

Where:

*v* = velocity (ft/sec)

*n* = Manning's roughness coefficient  
(0.013)

*R<sub>h</sub>* = hydraulic radius (ft)

*S* = slope (ft/ft)

**ATTACHMENT A**  
**(Engineering Design Report)**

**TERALTA PHASE II**  
**Engineering Design Report**  
**8" PVC SDR 26**

**TABLE OF CONTENTS**

INTRODUCTION ..... 2

PROJECT INFORMATION ..... 2

GRAVITY SANITARY SEWER PIPING: FLOW & CAPACITY ANALYSIS ..... 2

    Odor Control ..... 3

    Flow Calculation ..... 3

    Capacity Calculation ..... 4

    Conclusion ..... 5

GENERAL STRUCTURAL COMPONENTS ..... 6

    Project Materials (Bedding): ..... 6

    Project Materials (Manholes): ..... 7

    Project Materials (Manhole Covers): ..... 7

    Minimum and Maximum Slopes ..... 8

    Backfill ..... 8

    Trenching ..... 8

    Minimum and Maximum Trench Width ..... 8

    Corrosion Prevention ..... 9

    Manholes (General) ..... 9

    Manholes (Inverts) ..... 9

    Manholes (Ventilation) ..... 10

FLEXIBLE PIPE COMPUTATIONS ..... 10

    Live Load Calculations ..... 10

    Buckling Pressure Calculations ..... 10

    Allowable Buckling Pressure: ..... 11

    Pressure Under Installed Conditions ..... 12

    Wall Crushing Calculations ..... 13

    Installation Temperature Effects ..... 14

    Strain ..... 14

    Modulus of Soil Reaction ..... 14

**TERALTA PHASE II**  
**Engineering Design Report**  
**8" PVC SDR 26**

Zeta Calculation ..... 15

Pipe Stiffness ..... 16

Deflection ..... 16

# TERALTA PHASE II

## Engineering Design Report

### 8" PVC SDR 26

## INTRODUCTION

This Engineering Design Report has been prepared to comply with the Texas Commission on Environmental Quality's Design Criteria for Domestic Wastewater Systems (30 TAC 217), and regulations over the Edwards Aquifer Recharge Zone (30 TAC 213). Please note, throughout this application, the more stringent of SAWS, CoSA or TCEQ regulations shall apply.

## PROJECT INFORMATION

Teralta Phase II is a commercial development on an approximately 12.72-acre legal limit site. Teralta Phase II Sewage Collection System (SCS) Application proposes the construction of a total of approximately 157 linear feet (LF) of sanitary sewer main to serve the commercial development. The proposed alignment will consist of approximately 135 LF of 8-inch (8") polyvinyl chloride (PVC) SDR 26 gravity main and approximately 22 LF of 8-inch (8") PVC, SDR 26, 160-psi pressure rated sewer main centered over the waterline crossing. The proposed sanitary sewer main will tie into an existing San Antonio Water System sewer main. Regulated activities proposed include excavation, construction of sewer mains, backfill, and compaction. Approximately 0.36 acres may be disturbed as identified by the 50-foot envelope shown on the plans; however, an overall 6.23 acres may be disturbed for this phase of development.

This project will result in an estimated additional 66 Equivalent Dwelling Units (EDUs). Approximately 13,200 gallons per day (gpd) of average domestic wastewater flow is estimated to be generated by this project. Wastewater treatment and disposal for the area will be provided by the existing Steven M. Clouse Water Recycling Center (WRC) operated by SAWS. No naturally occurring sensitive geological features were identified on the site.

Please refer to Sheet C4.00 of the attached sewer plans, which shows the proposed service area and its topographic features. This system is designed to have a minimum structural life of 50 years. Safety considerations are the responsibility of the contractor.

## GRAVITY SANITARY SEWER PIPING: FLOW & CAPACITY ANALYSIS

Basis for average flow used for design of collection system (**check one or more**):

# TERALTA PHASE II

## Engineering Design Report

### 8" PVC SDR 26

Per Capita Contributions: \_\_\_\_\_  
Service Connections: \_\_\_\_\_ ✓  
Land Area and Use: \_\_\_\_\_ ✓  
Fixture Analysis: \_\_\_\_\_

### Odor Control

Odor Control is not necessary on this project as it is a gravity line and there will be no conditions where sewage is standing and will become septic.

### Flow Calculation

Peaking Factor used for design: 2.5

Peaking Factor is based on: SAWS Specifications for peak dry weather flow (from SAWS USR 11.3.1)

Total EDUs = 66 \*

\* The total number of EDUs includes flow from both currently proposed and anticipated future construction, as based on SAWS criteria.

1 EDU = 200 gallons per day (average sewage flow)  
= 500 gallons per day (peak flow)

Infiltration = 600 gallons per acre served

Avg. Flow = 66 EDUs x (200 gpd/EDU) + [(600 gpd/acre) x 6.23 acres] = 16,938 gpd = 11.76 gpm

Peak Flow = 66 EDUs x (500 gpd/EDU) + [(600 gpd/acre) x 6.23 acres] = 36,738 gpd = 25.51 gpm

Please note that capacities are determined using Manning's equation for pipes flowing full with an "n" value of 0.013. A reference for Manning's Equation can be found in "The Uni-Bell Handbook of PVC Pipe: Design and Construction".

# TERALTA PHASE II

## Engineering Design Report

### 8" PVC SDR 26

#### Capacity Calculation

Characteristics of 8" ASTM D3034, SDR 26, PVC Sewer Pipe:

Nominal Size = 8"

Outer Diameter ( $D_o$ ) = 8.40"

Minimum Wall Thickness ( $t$ ) = 0.323"

Inner Diameter ( $D_i$ ) = 7.75"

Characteristics of 8" ASTM 2241, Class 160, SDR 26, PVC Sewer Pipe:

Nominal Size = 8"

Outer Diameter ( $D_o$ ) = 8.625"

Minimum Wall Thickness ( $t$ ) = 0.332"

Inner Diameter ( $D_i$ ) = 7.961"

Manning's Equation:

$$Q = (k/n)(A)(R^{2/3})(S^{1/2})$$

$$v = Q/A$$

Where:

$Q$  = Discharge (cfs)

$k$  = Constant [(1.49 ft<sup>1/3</sup>)/sec.]

$n$  = Manning's roughness coefficient (unitless)

$A$  = Flow area (ft<sup>2</sup>)

$R$  = Hydraulic Radius (ft)

=  $A/P$  = Cross sectional area of flow (ft<sup>2</sup>)/Wetted perimeter (ft.)

$S$  = Slope (ft/ft)

$v$  = Velocity of flow (ft/s)

$n = 0.013$  [as required by 30 TAC 213.53 A(i)]

**TERALTA PHASE II**  
**Engineering Design Report**  
**8" PVC SDR 26**

Calculations for 8" ASTM D3034, SDR 26, PVC Sewer Pipe:

$$A = \pi(D_i^2)/4 = \pi(7.75 \text{ in})^2/4 = 47.17 \text{ in}^2 = 0.33 \text{ ft}^2$$

$$P = \pi(D_i) = \pi(7.75 \text{ in}) = 24.35 \text{ in} = 2.03 \text{ ft}$$

$$R = A/P = 0.33 \text{ ft}^2/2.03 \text{ ft} = 0.16 \text{ ft}$$

$$S = 0.01$$

$$Q = [(1.49 \text{ ft}^{1/3}/\text{sec})/0.013](0.33 \text{ ft}^2)(0.16 \text{ ft})^{2/3}(0.01)^{1/2}$$

$$Q = 1.11 \text{ cfs} = 500 \text{ gpm} = Q_{full}$$

$$v = 1.11 \text{ cfs}/0.33 \text{ ft}^2 = 3.40 \text{ ft/s}$$

$$Q_{max} = 1.11 \text{ cfs} (0.90)(7.48 \text{ gallons}/1 \text{ cf})(60 \text{ sec}/1 \text{ min.}) = 450 \text{ gpm}$$

Calculations for 8" ASTM 2241, Class 160, SDR 26, PVC Sewer Pipe:

$$A = \pi(D_i^2)/4 = \pi(7.961 \text{ in})^2/4 = 49.76 \text{ in}^2 = 0.35 \text{ ft}^2$$

$$P = \pi(D_i) = \pi(7.961 \text{ in}) = 25.01 \text{ in} = 2.08 \text{ ft}$$

$$R = A/P = 0.35 \text{ ft}^2/2.08 \text{ ft} = 0.17 \text{ ft}$$

$$S = 0.01$$

$$Q = [(1.49 \text{ ft}^{1/3}/\text{sec})/0.013](0.35 \text{ ft}^2)(0.17 \text{ ft})^{2/3}(0.01)^{1/2}$$

$$Q = 1.20 \text{ cfs} = 537 \text{ gpm} = Q_{full}$$

$$v = 1.20 \text{ cfs}/0.35 \text{ ft}^2 = 3.46 \text{ ft/s}$$

$$Q_{max} = 537 \text{ cfs} (0.90)(7.48 \text{ gallons}/1 \text{ cf})(60 \text{ sec}/1 \text{ min.}) = 483 \text{ gpm}$$

Nominal Main Size (in)	Outer Diameter (in)	Minimum Slope (%)	Area (ft <sup>2</sup> )	Hydraulic Radius (A/P) ft	R <sup>2/3</sup>	S <sup>1/2</sup>	Q-Full (cfs)	Max Pipe (%)	Velocity (ft/s)	Q-Max (gpm)
8 (NR)	8.40	1.0	0.33	0.16	0.29	0.1	1.11	90	3.40	450
8 (PR)	8.625	1.0	0.35	0.17	0.31	0.1	1.20	90	3.46	483

**Conclusion**

The proposed 8" pipe (NR & PR) with a minimum slope of 1.0% has sufficient capacity to convey the projected average and peak flows.

**TERALTA PHASE II**  
**Engineering Design Report**  
**8" PVC SDR 26**

**GENERAL STRUCTURAL COMPONENTS**

***Project Materials (Pipe and Joints):***

Nominal Pipe Diameter (in)	Linear Feet	Pipe Material	National Standard Specification for Pipe Material	National Standard for Pipe Joints
8 (NR)	135	PVC SDR 26	ASTM D3034	ASTM D3212
8 (PR)	22	PVC SDR 26	ASTM 2241, Class 160	ASTM D3139 ASTM C1173

Note: Section 217.53 (j)(4) requires a minimum pipe diameter of 6 inches for all gravity sanitary sewer collection system piping.

Watertight, size on size resilient connectors conforming to ASTM C-923 have been specified for connecting pipe to manholes. See SAWS Standard Specification for Construction Detail DD-852-01.

Where a collection system parallels a water supply pipe and a nine-foot separation distance cannot be achieved, Section 217.53 (d)(3)(A)(i) requires a collection system pipe be constructed of cast iron, ductile iron, or PVC meeting ASTM specifications with at least a 150 pounds per square inch (psi) rating for both the pipe and joints. The proposed project will comply with these requirements.

Where a collection system pipe crosses a water supply line and a nine-foot separation distance cannot be achieved, Section 217.53(d)(3)(B)(i) requires the collection system pipe be constructed of cast iron, ductile iron, or PVC with a minimum pressure rating of 150 psi. The proposed project will comply with this requirement and that of 217.53(d)(3)(B)(iii).

**Project Materials (Bedding):**

The specified bedding will comply with ASTM D2321-11 Class I, II or III for materials and densification. A minimum of 6 inches of bedding is required for all pipe.

**TERALTA PHASE II**  
**Engineering Design Report**  
**8" PVC SDR 26**

<b>Pipe Diameter (in)</b>	<b>Pipe Material</b>	<b>Bedding Class</b>
<i>8</i>	<i>PVC</i>	<i>Class I &amp; Class III</i>

The selection of bedding class is based on SAWS detail DD-804-01 for sanitary sewer pipe laid in a trench. Initial backfill for the pipe sizes shown above will be Class I. Secondary backfill will be Class III. See Table 2 of ASTM D2321-11 "Soil Classes" in Appendix A of this subsection.

**Project Materials (Manholes):**

Section 217.55 (f) prohibits the use of bricks to adjust a manhole cover to grade or construct a manhole. The proposed project will comply with this requirement.

The inside diameter of a manhole must be no less than 48 inches.

Section 217.55 (n) requires watertight, size-on-size resilient connectors that allow for differential settlement and must conform to American Society for Testing and Materials C-923. The proposed project complies with this requirement.

Under 30 TAC 213.5(C)(3)(A), all manholes over the Recharge Zone must be watertight, with watertight rings and covers. The proposed project complies with this requirement.

The materials specified for manhole construction are **precast concrete**.

**Project Materials (Manhole Covers):**

Manhole covers must be constructed of impervious materials. If personnel entry is required, a minimum 30-inch diameter clear opening must be provided. Inclusion of steps in a manhole is prohibited. If a manhole must be located within a 100-year flood plain, then a means of preventing inflow is required. A manhole cover that is located in a roadway must meet or exceed the American Association of State Highways and Transportation Officials Standard M-306 for load bearing.

Under 30 TAC 213.5 (c)(3)(A), all manholes over the Edwards Aquifer Recharge Zone must be watertight, with watertight rings and covers. This proposed project complies with this requirement.

# TERALTA PHASE II

## Engineering Design Report

### 8" PVC SDR 26

#### Minimum and Maximum Slopes

Note: All pipes are designed with a slope that will provide a velocity of at least 2 ft/s flowing full, as calculated using Manning's equation with an "n" value of 0.013. Additionally, the collection system is designed to ensure that, with pipes flowing full, the velocities will be less than 10 feet per second.

The following are the minimum and maximum slopes for each pipe diameter:

Pipe Diameter: 8" (NR and PR) Min. Slope: 1.0% Max. Slope: 1.0%

#### Backfill

Note: The backfill will be free of stones greater than 6 inches in diameter and free of organic or any other unstable material. See SAWS Item No. 804 for additional specifications.

#### Trenching

Note: The trench width will be minimized while still allowing adequate width for proper compaction of backfill, and while still ensuring that at least 6 inches of backfill exists below and on each side of the pipe. The trench walls will be vertical to at least one foot above the pipe.

Trenching will occur over the Recharge Zone and will comply with 30 TAC 213.5.

#### Minimum and Maximum Trench Width

Based on SAWS Standard Drawing DD-804-01 and 30 TAC 217.54:

Pipe Diameter: 8" (NR) Min. Trench Width: 22" Max. Trench Width: 34"

Pipe Diameter: 8" (PR) Min. Trench Width: 23" Max. Trench Width: 35"

These trench widths account for the bell diameter.

# TERALTA PHASE II

## Engineering Design Report

### 8" PVC SDR 26

#### Corrosion Prevention

Proposed collection system components (pipes, manholes, etc.) will not be susceptible to deterioration through the corrosive effects of an anaerobic sewage environment. The interior of the manholes, however, are to be coated with a SAWS approved sewer structural coating per SAWS April 2014 Standard Specifications (Item No. 852, Section 852.3, Item 5). Epoxy coating specifically approved. The epoxy coating on the interior walls of the manhole provide interior corrosion protection.

#### Manholes (General)

Note: Manholes are provided at all changes in size, grade or alignment of pipe, at the intersection of all pipes and at the end of all lines that may be extended at a future date. A clean-out with watertight plugs may be installed instead of a manhole if no extensions are anticipated. Clean outs must pass all testing requirements outlined for gravity collection pipes.

The project complies with the maximum manhole spacing allowed by the TCEQ:

Pipe Diameter (in)	Max. Manhole Spacing (ft)
6 - 15	500
18 - 30	800
36 - 48	1000
54 or larger	2000

Manhole Spacing:

Pipe Diameter: 8" Max. Spacing: 157 LF

See SAWS Standard Specification in Appendix B for additional manhole specifications.

#### Manholes (Inverts)

The bottom of a manhole must contain a U-shaped channel, which is a smooth continuation of the inlet, and outlet pipes. The bench above the channel must be sloped a minimum of 0.5 inches per foot. See

## **TERALTA PHASE II**

### **Engineering Design Report**

### **8" PVC SDR 26**

SAWS detail DD-852-01, which complies with these requirements. Note, a manhole connected to a pipe less than 15 inches in diameter must have a channel depth equal to at least half the largest pipe's diameter.

#### **Manholes (Ventilation)**

Vented manholes are not proposed for this SCS.

#### **FLEXIBLE PIPE COMPUTATIONS**

Please note, all flexible pipe computations are based on engineering principles and practices for the design of buried PVC pipe systems. Equations used can be found in "The Uni-Bell PVC Pipe Association Handbook of PVC Pipe: Design and Construction". Please note, the equations used may be in a different format than shown in the Uni-Bell Handbook. Throughout this application "160 psi" pipe refers to the pressure rating of the ASTM 2241, Class 160, SDR 26 pipe used throughout the SCS.

#### **Live Load Calculations**

Minimum burial depth without concrete encasement is nine (9) feet. Based on Table 6-6 Live Loads on PVC pipe (from Uni-Bell Handbook for PVC) for this sewer line would be 0.69 psi.

#### **Buckling Pressure Calculations**

This area of the Edwards Aquifer is unsaturated; consequently, there are no anticipated areas where sewer pipe will be placed below the water table. The value of  $h_w=0$  as there will be no height or time period of perched water or groundwater above the pipe crowns of the proposed sewer line.

The value of H for use in these calculations is thirteen (13) feet as it exceeds the maximum burial depth for this line. The value of  $\gamma_s$  equals 143 pcf is a conservative value based on a dry unit weight of 135 pcf and a moisture content of 6%. This value is conservative as it corresponds to saturated unit weights of commonly used backfill materials. Please see information from Raba-Kistner provided in Appendix C.

**TERALTA PHASE II**  
**Engineering Design Report**  
**8" PVC SDR 26**

**Allowable Buckling Pressure:**

$$q_a = 0.4 * \sqrt{32 * R_w * B' * E_b * (E * I / D^3)} \quad \text{Equation 1}$$

$$q_a = 0.4 * \sqrt{32 * 1 * 0.37 * 400 * (400,000 * .003/8.08^3)} = 40.08 \text{ psi (8" PVC SDR 26 (NR))}$$

$$q_a = 0.4 * \sqrt{32 * 1 * 0.37 * 400 * (400,000 * .003/8.29^3)} = 40.14 \text{ psi (8" PVC SDR 26 (PR))}$$

$$R_w = 1 - 0.33 * (h_w/h) \quad \text{Equation 2}$$

$$R_w = 1 - 0.33 * (0/240) = 1$$

$$B' = \frac{1}{1 + 4 * e^{-.065 * H}} \quad \text{Equation 3}$$

$$B' = \frac{1}{1 + 4 * e^{-.065 * 13}} = 0.37$$

$$I = t^3/12 * (\text{inches}^4/\text{linear inch}) \quad \text{Equation 4}$$

$$I = .323^3/12 = .003\text{in}^3 \text{ (8" PVC SDR 26 (NR))}$$

$$I = .332^3/12 = .003\text{in}^3 \text{ (8" PVC SDR 26 (PR))}$$

$$D = D_o - t \quad \text{Equation 5}$$

$$D = 8.4 \text{ inches} - 0.323 \text{ inches} = 8.08 \text{ inches (8" PVC SDR26 (NR))}$$

$$D = 8.625 \text{ inches} - 0.332 \text{ inches} = 8.29 \text{ inches (8" PVC SDR26 (PR))}$$

## TERALTA PHASE II

### Engineering Design Report

### 8" PVC SDR 26

Where:

- $q_a$  = Allowable buckling pressure, pounds per square inch (psi)
- $h$  = Height of soil surface above top of pipe in inches (in)
- $h_w$  = Height of water surface above top of pipe in inches (in) (groundwater elevation)
- $R_w$  = Water buoyancy factor. If  $h_w = 0$ ,  $R_w = 1$ . If  $0 \leq h_w \leq h$  (groundwater elevation is between the top of the pipe and the ground surface), calculate  $R_w$  with Equation 2
- $H$  = Depth of burial in feet (ft) from ground surface to crown of pipe.
- $B'$  = Empirical coefficient of elastic support
- $E_b$  = Modulus of soil reaction for the bedding material (psi)
- $E$  = Modulus of elasticity of the pipe material (psi)
- $I$  = Moment of inertia of the pipe wall cross section per linear inch of pipe,  $\text{inch}^4/\text{linear inch} = \text{inch}^3$ . For solid wall pipe, "I" can be calculated with Equation 4
- $t$  = Pipe structural wall thickness (in)
- $D$  = Mean pipe diameter (in)
- $D_o$  = Pipe outer diameter (in)

### Pressure Under Installed Conditions

$$q_p = \gamma_w * h_w + R_w * (W_c/D) + L_l \quad \text{Equation 6}$$

$$q_p = 0.361 * 0 + 1 * (108.44/8.08) + 0.69 = 14.12 \text{ psi (8" PVC SDR26 (NR))}$$

$$q_p = 0.361 * 0 + 1 * (111.35/8.29) + 0.69 = 14.12 \text{ psi (8" PVC SDR26 (PR))}$$

Where:

- $q_p$  = Pressure applied to pipe under installed conditions (psi)
- $\gamma_w$  = 0.0361 pounds per cubic inch (pci), specific weight of water
- $W_c$  = Vertical soil load on the pipe per unit length in pounds per linear inch (lb/in)
- $L_l$  = Live load (lbs)
- $\gamma_s$  = Specific weight of soil in pounds per cubic foot (pcf)
- $D$  = Mean pipe diameter (in)

## TERALTA PHASE II

### Engineering Design Report

### 8" PVC SDR 26

$$W_c = \gamma_s * H * (D + t)/144 \quad \text{Equation 7}$$

$$W_c = 143 * 13 * (8.08 + 0.323)/144 = 108.44 \text{ b/in}^2 \text{ (8" PVC SDR 26 (NR))}$$

$$W_c = 143 * 13 * (8.29 + 0.332)/144 = 111.35 \text{ lb/in}^2 \text{ (8" PVC SDR 26 (PR))}$$

Pipe Diameter: **8" (NR)** Pipe Material: **PVC, SDR 26**  $q_a$ : **40.08**  $q_p$ : **14.12**

Pipe Diameter: **8" (PR)** Pipe Material: **PVC, SDR 26**  $q_a$ : **40.14**  $q_p$ : **14.12**

Since  $q_a \geq q_p$ , the specific pipe is acceptable for the proposed installation.

### Wall Crushing Calculations

No portion of the proposed SCS is located in the 5-year floodplain.

$$H = (24 * P_c * A) / (\gamma_s * D_o) \quad \text{Equation 8}$$

$$H = 24 * 4000 * 3.876 / 143 * 8.40 = 309.77 \text{ (8" PVC SDR 26 (NR))}$$

$$H = 24 * 4000 * 3.984 / 143 * 8.6250 = 310.10 \text{ (8" PVC SDR 26 (PR))}$$

$$A = t(\text{in}) * 12(\text{in}/\text{ft}) \quad \text{Equation 9}$$

$$A = 0.323 * 12 = 3.876 \text{ (8" PVC SDR 26 (NR))}$$

$$A = 0.332 * 12 = 3.984 \text{ (8" PVC SDR 26 (PR))}$$

Where:

$D_o$  = outside pipe diameter, in.

$P_c$  = compressive stress or hydrostatic design basis (HDB). For typical PVC pipe assume 4,000 psi. For any other pipe material, the HDB must be supplied by the pipe manufacturer.

$A$  = surface area of the pipe wall, in.<sup>2</sup>/ft [conversion factor of 12 applied to change from ft. to in.]

$\gamma_s$  = specific weight of soil in pounds per cubic foot (pcf)

$H$  = Depth of burial in feet (ft) from ground surface to crown of pipe.

24 = conversions and coefficients

## TERALTA PHASE II

### Engineering Design Report

### 8" PVC SDR 26

#### Installation Temperature Effects

Flexible pipe will be installed under favorable ambient conditions, per pipe manufacturer's specifications.

#### *Tensile Strength*

The information below is from "The Uni-Bell Handbook of PVC Pipe: Design and Construction" Table 2.1 pages 14-15. This applies to all PVC SDR-26 pipe.

Pipe Material: PVC SDR 26      Tensile Strength: 7,000      Cell Class (PVC only) 12454

#### Strain

The conditions of this installation are such that strain-related failure will not be a problem. Strain is generally not a performance-limiting factor for buried PVC pipe or a design-limiting criterion for PVC pipes according to the Uni-Bell Handbook of PVC Pipe (Chapter VII, Pages 255 and 257). As pipe deflection will be below 5%, strain-related failure is not anticipated.

#### Modulus of Soil Reaction

The modulus of soil reaction for the bedding material,  $E_b$ , is 400 psi.

This value was determined using the "Table 1: Soil Classification Chart" and "Table 2: Soil Classes" from ASTM D2321-11 and "Average Values of Modulus of Soil Reaction,  $E$ " Table 7.3 from "The Uni-Bell Handbook of PVC Pipe: Design and Construction" attached in Appendix A of this subsection. Based on SAWS detail DD-804-01, Class III material was chosen. As the secondary backfill (Class III) has a lower Modulus of Soil Reaction than initial backfill (Class I), its value was used in the calculations that follow. Class III on Table 2 corresponds to coarse-grained soils with fines (GM, GC, SM or SC) and sandy or gravelly fine-grained soils (CL or ML). On Table 7.3, coarse-grained soils with fines at a slight compaction have an  $E'$  equal to 400 psi.

The modulus of soil reaction for the in-situ soil,  $E'_n$ , is 3,000 psi

**TERALTA PHASE II**  
**Engineering Design Report**  
**8" PVC SDR 26**

This value was determined using the "Table 1: Soil Classification Chart" and "Table 2: Soil Classes" from ASTM D 2321-11 and "Average Values of Modulus of Soil Reaction, E" Table 7.3 from "The Uni-Bell Handbook of PVC Pipe: Design and Construction" attached in Appendix A of this subsection. Based on SAWS detail DD-804-01, Class I material was chosen, which includes crushed rock as shown on Table 2. Compacted crushed rock on Table 7.3 has an E' equal to 3,000 psi. Values in Table 7.3 are based on empirical data and derived from laboratory and field tests for buried pipe.

Bedding to in-situ soil modulus of soil reaction ratio =  $E_b/E'_n = 400 \text{ psi}/3,000 \text{ psi} = 0.13$

**Zeta Calculation**

Where native soil is significantly weaker than bedding material, or where predicted deflection approaches 5%, the effect of native soil must be quantified using Leonhardt's Zeta factor. If the ration of bedding modulus to soil modulus is not equal to 1.0, a zeta factor must be calculated by using the equations below, where zeta is a factor, which corrects for the effect of in-situ soil on pipe stability (Uni-Bell Handbook of Pipe, page 267). To calculate zeta, directly use the formulas below. The calculations that are done to determine the zeta factors for the different pipe diameters must be included with this submittal.

$$\text{zeta} = \frac{1.44}{f + (1.44 - f) * (E_b/E'_n)} \tag{Equation 10}$$

$$\text{zeta} = \frac{1.44}{1.22 + (1.44 - 1.22) * 0.13} = 1.15(8'' \text{ PVC SDR 26 (NR)})$$

$$\text{zeta} = \frac{1.44}{1.22 + (1.44 - 1.22) * 0.13} = 1.15(8'' \text{ PVC SDR 26 (PR)})$$

$$f = \frac{(b/d_a) - 1}{1.154 + 0.444 * ((b/d_a) - 1)} \tag{Equation 11}$$

$$f = \frac{(34/8.40) - 1}{1.154 + 0.444 * ((34/8.40) - 1)} = 1.22(8'' \text{ PVC SDR 26 (NR)})$$

$$f = \frac{(35/8.625) - 1}{1.154 + 0.444 * ((35/8.625) - 1)} = 1.22(8'' \text{ PVC SDR 26 (PR)})$$

## TERALTA PHASE II

### Engineering Design Report

### 8" PVC SDR 26

Where:

- f = Pipe/trench width coefficient
- b = Trench width (in)
- d<sub>a</sub> = Pipe diameter (in)
- E<sub>b</sub> = Modulus of soil reaction for the bedding material (psi)
- E'<sub>n</sub> = Modulus of soil reaction for the in-situ soil (psi)

Pipe Diameter: 8" (NR) Trench Width: 34" Zeta: 1.15

Pipe Diameter: 8" (PR) Trench Width: 35" Zeta: 1.15

### Pipe Stiffness

Ps is based on National Reference Standards and manufacturer's data. Please see Table 7.1 of the "The Uni-Bell Handbook of PVC Pipe: Design and Construction" listing the pipe stiffness of 8" PVC SDR 26 as 115 psi for E = 400,000 psi.

Pipe Diameter: 8" Pipe Material: PVC SDR 26 Ps: 115 psi

### Deflection

Maximum allowable deflection in installed lines is 5% (per 30 TAC 217), as determined by the deflection analysis and verified by a mandrel test. It is recommended that the percent of vertical deflection is below this range; however, a 7.5% deflection limit (recommended by ASTM D3034) provides a conservative factor of safety against structural failure (Handbook of PVC Pipe, page 249).

Note: Per Table 7.2 attached in Appendix A of the SCS Application, K = 0.096 when the bedding angle is 90 degrees. A bedding angle of 90 degrees is required as shown on SAWS detail DD-804-01.

**TERALTA PHASE II**  
**Engineering Design Report**  
**8" PVC SDR 26**

$$\Delta Y/D(\%) = \frac{K * (L_p + L_1) * 100}{(0.149 * P_s) + (0.061 * \text{zeta} * E_b)} \quad \text{Equation 12}$$

$$\Delta Y/D(\%) = \frac{0.096 * (12.91 + 0.69) * 100}{(0.149 * 115) + (0.061 * 1.15 * 400)} = 2.73\%(8''\text{PVC SDR 26 (NR)})$$

$$\Delta Y/D(\%) = \frac{0.096 * (12.91 + 0.69) * 100}{(0.149 * 115) + (0.061 * 1.15 * 400)} = 2.73\%(8''\text{PVC SDR 26 (PR)})$$

$$L_p = \frac{\gamma_s * H}{144} \quad \text{Equation 13}$$

$$L_p = \frac{143 * 13}{144} = 12.91 \text{ psi}$$

Where:

- %ΔY/D = Predicted % vertical deflection under load
- ΔY = Change in vertical pipe diameter under load
- D = Undeformed mean pipe diameter (in)
- K = Bedding angle constant
- γ<sub>s</sub> = Unit weight of soil (pcf)
- H = Depth of burial (ft) from ground surface to crown of pipe
- L<sub>p</sub> = Prism load (psi)

Type of Pipe Material	P <sub>s</sub> (psi)	Zeta Factor Assumed or Calculated	E <sub>b</sub> (psi)	% Deflection
8" PVC SDR 26 (NR)	115	1.15	400	2.73
8" PVC SDR 26 (PR)	115	1.15	400	2.73

All pipes proposed for this project have a maximum predicted deflection below 5.0%

**TERALTA PHASE II  
Engineering Design Report  
8" PVC SDR 26**

Signature, Seal and Date of the Texas Professional Engineer Below:

*Andrew Belton*



4/10/24

# **APPENDIX A (TABLES)**

## SOIL CLASSIFICATION CHART

### From ASTM D2321-11: Standard Practice for Underground Installation of Thermoplastic Pipe for Sewers and Other Gravity-Flow Applications

TABLE 1 Soil Classification Chart (see Classification D2487)

Criteria for Assigning Group Symbols and Group Names Using Laboratory Tests <sup>A</sup>				Soil Classification			
				Group Symbol	Group Name <sup>B</sup>		
Coarse-Grained Soils  More than 50% retained on No. 200 sieve	Gravels	Clean gravels	$C \geq 4$ and $1 \leq C_c \leq 3^C$	GW	Well-graded gravel <sup>D</sup>		
	More than 50% of coarse fraction retained on No. 4 sieve	Sands	Less than 5% of fines <sup>E</sup>	$C_u < 4$ and/or $1 > C_c > 3^C$	GP	Poorly graded gravel <sup>D</sup>	
			Gravels with more than 12% fines <sup>E</sup>	Fines classify as ML or MH	GM	Silty gravel <sup>DFG</sup>	
		50% or more of coarse fraction passes on No. 4 sieve	Sands	Clean sands	$C_u \geq 6$ and $1 \leq C_c \leq 3^C$	SW	Well-graded sand <sup>H</sup>
				Less than 5% fines <sup>I</sup>	$C_u < 6$ and/or $1 > C_c > 3^C$	SP	Poorly graded sand <sup>H</sup>
			Sand with fines	Fines classify as ML or MH	SM	Silty sand <sup>FGH</sup>	
			More than 12% fines <sup>I</sup>	Fines classify as CL or CH	SC	Clayey sand <sup>FGH</sup>	
	Fine-Grained Soils  50% or more passes the No. 200 Sieve	Silts and clays	Inorganic	$PI > 7$ and plots on or above "A" line <sup>J</sup>	CL	Lean clay <sup>KLM</sup>	
			Liquid limit less than 50	$PI < 4$ and plots below "A" line <sup>J</sup>	ML	silt <sup>KLM</sup>	
		Silts and clays  Liquid limit 50 or more	Inorganic	Liquid Limit-Oven dried	$< 0.75$	OL	Organic clay <sup>KLMN</sup>
Liquid Limit-Not dried						Organic silt <sup>KLMO</sup>	
Inorganic			PI plots on or above "A" line		CH	Fat clay <sup>KLM</sup>	
			Plots below "A" line		MH	Elastic silt <sup>KLM</sup>	
Organic	Liquid Limit-Oven Dried	$< 0.75$	OH	Organic clay <sup>KLMP</sup>			
	Liquid Limit-Not Dried			Organic silt <sup>KLMO</sup>			
Highly organic soils	Primarily organic matter, dark in color, and organic odor			PT	peat		

<sup>A</sup> Based on the material passing the 3-in. (75-mm) sieve.

<sup>B</sup> If field sample contained cobbles or boulders, or both, add "with cobbles or boulders, or both" to group name.

<sup>C</sup>  $C_u = D_{60} / D_{10}$

$$C_c = \frac{(D_{30})^2}{D_{10} \times D_{60}}$$

<sup>D</sup> If soil contains  $\geq 15\%$  sand, add "with sand" to group name.

<sup>E</sup> Gravels with 5 to 12 % fines require dual symbols:

- GW-GM well-graded gravel with silt:
- GW-GC well-graded gravel with clay
- GP-GM poorly graded gravel with silt
- GP-GC poorly graded gravel with clay

<sup>F</sup> If fines classify as CL-ML, use dual symbol GC-GM, or SC-SM.

<sup>G</sup> If fines are organic, add "with organic fines" to group name.

<sup>H</sup> If soil contains  $\geq 15\%$  gravel, add "with gravel" to group name.

<sup>I</sup> Sands with 5 to 12 % fines require dual symbols:

- SW-SM well graded sand with silt
- SW-SC well-graded sand with clay
- SP-SM poorly graded sand with silt
- SP-SC poorly graded sand with clay

<sup>J</sup> If Atterberg limits plot in hatched area, soil is a CL-ML, silty clay (see Test Method D4318).

<sup>K</sup> If soil contains 15 to 29 % plus No. 200, add "with sand" or "with gravel", whichever is predominant.

<sup>L</sup> If soil contains  $\geq 30\%$  plus No. 200, predominantly sand, add "sandy" to group name.

<sup>M</sup> If soil contains  $\geq 30\%$  plus No. 200, predominantly gravel, add "gravelly" to group name.

<sup>N</sup>  $PI \geq 4$  and plots on or above "A" line.

<sup>O</sup>  $PI < 4$  or plots below "A" line.

<sup>P</sup>  $PI$  plots on or above "A" line.

<sup>Q</sup>  $PI$  plots below "A" line.

## SOIL CLASSIFICATION CHART

### From ASTM D2321-11: Standard Practice for Underground Installation of Thermoplastic Pipe for Sewers and Other Gravity-Flow Applications

**TABLE 2 Soil Classes**

Soil Group <sup>A,B</sup>	Soil Class	American Association of State Highway and Transportation Officials (AASHTO) Soil Groups <sup>C</sup>
Crushed rock, angular <sup>D</sup> , 100% passing 1-1/2 in. sieve, $\leq$ 15 % passing #4 sieve, $\leq$ 25 % passing 3/8 in. sieve and $\leq$ 12 % passing #200 sieve	Class I	--
Clean, coarse grained soils: SW, SP, GW, GP or any soil beginning with one of these symbols with $\leq$ 12 % passing #200 sieve <sup>E,F</sup>	Class II	A1, A3
Coarse grained soils with fines: GM, GC, SM, SC or any soil beginning with one of these symbols, containing > 12 % passing #200 sieve; Sandy or gravelly fine-grained soils: CL, ML, or any soil beginning with one of these symbols, with $\geq$ 30 % retained on #200 sieve	Class III	A-2-4, A-2-5, A-2-6, or A-4 or A-6 soils with more than 30% retained on #200 sieve
Fine-grained soils: CL, ML, or any soil beginning with one of these symbols, with $<$ 30 % retained on #200 sieve	Class IV	A-2-7, or A-4, or A-6 soils with 30% or less retained on #200 sieve
MH, CH, OL, OH, PT	Class V Not for use as embedment	A5, A7

<sup>A</sup> See Classification D2487, Standard Classification of Soils for Engineering Purposes (Unified Soil Classification System).

<sup>B</sup> Limits may be imposed on the soil group to meet project or local requirements if the specified soil remains within the group. For example, some project applications require a Class I material with minimal fines to address specific structural or hydraulic conditions and the specification may read "Use Class I soil with a maximum of 5% passing the #200 sieve."

<sup>C</sup> AASHTO M145, Classification of Soils and Soil Aggregate Mixtures.

<sup>D</sup> All particle face shall be fractured.

<sup>E</sup> Materials such as broken coral, shells, and recycled concrete, with  $\leq$  12% passing a No. 200 sieve, are considered to be Class II materials. These materials should only be used when evaluated and approved by the Engineer.

<sup>F</sup> Uniform fine sands (SP) with more than 50% passing a No. 100 sieve (0.006 in., 0.15 mm) are very sensitive to moisture and should not be used as backfill unless specifically allowed in the contract documents. If use of these materials is allowed, compaction and handling procedures should follow the guidelines for Class III materials.

## SOIL CLASSIFICATION CHART

### From ASTM D2321-11: Standard Practice for Underground Installation of Thermoplastic Pipe for Sewers and Other Gravity-Flow Applications

**TABLE 3 Recommendations for Installation and Use of Soils and Aggregates for Foundation and Pipe-Zone Embedment**

Soil Class <sup>A</sup>	Class I <sup>B</sup>	Class II	Class III	Class IV
General Recommendations and Restrictions	Acceptable and common where no migration is probable or when combined with a geotextile filter media. Suitable for use as a drainage blanket and under drain where adjacent material is suitably graded or when used with a geotextile filter fabric (see X1.8).	Where hydraulic gradient exists check gradation to minimize migration. Clean groups are suitable for use as a drainage blanket and underdrain (see Table 2). Uniform fine sands (SP) with more than 50 % passing a #100 sieve (0.006 in., 0.15 mm) behave like silts and should be treated as Class IV soils.	Do not use where water conditions in trench prevent proper placement and compaction. Not recommended for use with pipes with stiffness of 9 psi or less.	Difficult to achieve high-soil stiffness. Do not use where water conditions in trench prevent proper placement and compaction. Not recommended for use with pipes with stiffness of 9 psi or less.
Foundation	Suitable as foundation and for replacing over-excavated and unstable trench bottom as restricted above.	Suitable as foundation and for replacing over-excavated and unstable trench bottom as restricted above. Install and compact in 12 in. (300 mm) maximum layers.	Suitable for replacing over-excavated trench bottom as restricted above. Install and compact in 6 in. (150 mm) maximum layers.	Suitable for replacing over-excavated trench bottom as restricted above. Install and compact in 6-in (150 mm) maximum layers.
Pipe Embedment	Suitable as restricted above. Work material under pipe to provide uniform haunch support.	Suitable as restricted above. Work material under pipe to provide uniform haunch support.	Suitable as restricted above. Difficult to place and compact in the haunch zone.	Suitable as restricted above. Difficult to place and compact in the haunch zone.
Embedment Compaction: Min Recommended Percent Compaction, SPD <sup>D</sup>	See Note <sup>C</sup>	85 % (SW and SP soils) For GW and GP soils See Note <sup>E</sup>	90 %	95 %
Relative Compactive Effort Required to Achieve Minimum Percent Compaction	Low	Moderate	High	Very high
Compaction Methods	Vibration or impact	Vibration or impact	Impact	Impact
Required Moisture Control	None	None	Maintain near optimum to minimize compactive effort	Maintain near optimum to minimize compactive effort

<sup>A</sup> Class V materials are unsuitable as embedment. They may be used as final backfill as permitted by the engineer.

<sup>B</sup> Class I materials have higher stiffness than Class II materials, but data on specific soil stiffness of placed, uncompacted Class I materials can be taken equivalent to Class II materials compacted to 95% of maximum standard Proctor density (SPD95), and the soil stiffness of compacted Class I materials can be taken equivalent to Class II materials compacted to 100% of maximum standard Proctor density (SPD100). Even if placed uncompacted (that is, dumped), Class I materials should always be worked into the haunch zone to assure completed placement.

<sup>C</sup> Suitable compaction typically achieved by dumped placement (that is, uncompacted but worked into haunch zone to ensure complete placement).

<sup>D</sup> SPD is standard Proctor density as determined by Test Method D698.

<sup>E</sup> Place and compact GW and GP soils with at least two passes of compaction equipment.

**TABLE 6.6**  
**LIVE LOADS ON PVC PIPE**  
**From Uni-Bell Handbook of PVC Pipe: Design and Construction, Fourth Edition (2001)**

Height of Cover (ft)	Live Load Transferred to Pipe, lb/in <sup>2</sup>			Height of Cover (ft)	Live Load Transferred to Pipe, lb/in <sup>2</sup>		
	Highway H20 <sup>1</sup>	Railway E80 <sup>2</sup>	Airport <sup>3</sup>		Highway H20 <sup>1</sup>	Railway E80 <sup>2</sup>	Airport <sup>3</sup>
1	12.50			14	*	4.17	3.06
2	5.56	26.39	13.14	16	*	3.47	2.29
3	4.17	23.61	12.28	18	*	2.78	1.91
4	2.78	18.40	11.27	20	*	2.08	1.53
5	1.74	16.67	10.09	22	*	1.91	1.14
6	1.39	15.63	8.79	24	*	1.74	1.05
7	1.22	12.15	7.85	26	*	1.39	*
8	0.69	11.11	6.93	28	*	1.04	*
10	*	7.64	6.09	30	*	0.69	*
12	*	5.56	4.76	35	*	*	*
				40	*	*	*

<sup>1</sup> Simulates 20 ton truck traffic + impact (Source: ASTM A 796)

<sup>2</sup> Simulates 80,000 lb/ft railway load + impact (Source: ASTM A 796)

<sup>3</sup> 180,000 lbs. dual tandem gear assembly. 26 inch spacing between tires and 66 inch center-to-center spacing between fore and aft tires under a rigid pavement 12 inches thick + impact.

\* Negligible live load influence.

**FIGURE 7.4  
BEDDING ANGLE**

From Uni-Bell Handbook of PVC Pipe: Design and Construction, Fourth Edition (2001)

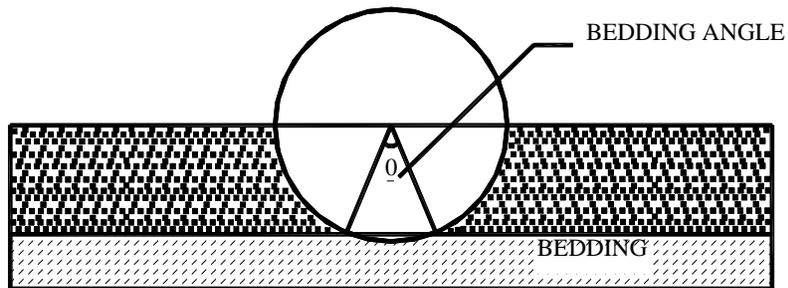

**TABLE 7.2  
VALUES OF BEDDING CONSTANT, K**

<u>BEDDING ANGLE (DEGREES)</u>	<u>K</u>
0	0.110
30	0.108
45	0.105
60	0.102
90	0.096
120	0.090
180	0.083

**TABLE 7.3**  
**AVERAGE VALUES OF MODULUS OF SOIL REACTION, E'**  
**(For Initial Flexible Pipe Deflection)**

From Uni-Bell Handbook of PVC Pipe: Design and Construction, Fourth Edition (2001)

Soil type-pipe bedding material (Unified Classification System <sup>a</sup> ) (1)	E' for Degree of Compaction of Bedding, in pounds per square inch			
	Dumped (2)	Slight, < 85% Proctor, <40% relative density (3)	Moderate, 85%-95% Proctor, 40%-70% relative density (4)	High, >95% Proctor, >70% relative density (5)
Fine-grained Soils (LL>50) <sup>b</sup> Soils with medium to high plasticity, CH, MH, CH-MH	No data available; consult a competent soils engineer; Otherwise use E' = 0			
Fine-grained Soils (LL<50) Soils with medium to no plasticity, CL, ML, ML-CL, with less than 25% coarse- grained particles	50	200	400	1,000
Fine-grained Soils (LL<50) Soils with medium to no plasticity, CL, ML, ML-CL, with more than 25% coarse-grained particles Coarse-grained Soils with Fines GM, GC, SM, SC <sup>c</sup> contains more than 12% fines	100	400	1,000	2,000
Coarse-grained Soils with Little or no Fines GW, GP, SW, SP <sup>c</sup> contains less than 12% fines	200	1,000	2,000	3,000
Crushed Rock	1,000	3,000	3,000	3,000
Accuracy in Terms of Percentage Deflection <sup>d</sup>	± 2	± 2	± 1	± 0.5
<sup>a</sup> ASTM Designation D 2487, USBR Designation E-3. <sup>b</sup> LL = Liquid limit. <sup>c</sup> Or any borderline soil beginning with one of these symbols (i.e. GM-GC, GC-SC). <sup>d</sup> For ± 1% accuracy and predicted deflection of 3%, actual deflection would be between 2% and 4%  Note: Values applicable only for fills less than 50 ft (15 m). Table does not include any safety factor. For use in predicting initial deflections only, appropriate Deflection Lag Factor must be applied for long-term deflections. If bedding falls on the borderline between two compaction categories, select lower E' value or average the two values. Percentage Proctor based on laboratory maximum dry density from test standards using about 12,500 ft-lb/cu ft (598,000 J/m <sup>3</sup> ) (ASTM D 698, AASHTO T-99, USBR Designation E-11). 1 psi = 6.9 kPa.				

SOURCE: "Soil Reaction for Buried Flexible Pipe" by Amster K. Howard, U.S. Bureau of Reclamation, Denver, Colorado. Reprinted with permission from American Society of Civil Engineers.

# **APPENDIX B (SOIL UNIT WEIGHT VALUES)**



**Raba-Kistner Consultants, Inc.**

12821 W. Golden Lane  
 P.O. Box 690287, San Antonio, TX 78269-0287  
 (210) 699-9090 • FAX (210) 699-6426  
 www.rkci.com

January 14, 2009

Charles P. "Frosty" Forster, P.E., P.G.  
 Pape Dawson Engineers  
 555 East Ramsey  
 San Antonio, Texas 78216

**RE: Soil Unit Weight Values for Backfill Materials  
 Various Projects  
 San Antonio, Texas**

Dear Mr. Forster:

**Raba-Kistner Consultants Inc. (R-K)** is pleased to submit this letter providing general guidance for selecting design soil unit weights for use in utility trench design.

In general, the following table contains a list of the frequently used trench backfill materials in the San Antonio area. The table also contains approximate values for the soil dry unit weight, moist unit weight and saturated unit weight for these materials assuming 90 to 95 percent compaction utilizing a standard Proctor (ASTM D 698.)

MATERIAL DESCRIPTION	DRY UNIT WEIGHT, PCF	MOIST UNIT WEIGHT, PCF	SATURATED UNIT WEIGHT, PCF
TxDOT TEX-113E Type A, Gr. 1 or 2	130	137	143
TxDOT TEX-113E Type A, Gr. 3 thru 5	128	135	143
Limestone Millings	115	124	134
Gravelly Clay	110	120	132
Clay	100	120	127
Clayey Sand	95	106	123
Gravel (Clean)	115	120	134
Sand (Clean)	92	98	120
Pit Run Gravel	127	137	142

We appreciate the opportunity to be of service to you. If you have any questions or need additional assistance, please call.

Very truly yours,

**RABA-KISTNER CONSULTANTS, INC.**

*[Handwritten Signature]*  
 1/14/09

Chris L. Schultz, P.E.  
 Senior Vice President

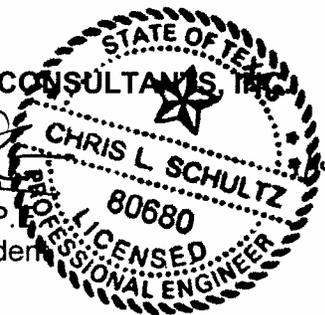

CLS/mem

**APPENDIX C (STANDARD SPECS  
AND PRE-CAST MANHOLES  
SPECS)**

## 30 TAC 217 regulations will apply where more stringent than the following SAWS Specifications

Specification 852: Sanitary Sewer Manholes

[https://apps.saws.org/business\\_center/specs/constspecs/docs/conspecs\\_2021/ITEM%20NO.%20852%20Sanitary%20Sewer%20Manholes.pdf](https://apps.saws.org/business_center/specs/constspecs/docs/conspecs_2021/ITEM%20NO.%20852%20Sanitary%20Sewer%20Manholes.pdf)

Specification 854: Sanitary Sewer Laterals

[https://apps.saws.org/business\\_center/specs/constspecs/docs/conspecs\\_2021/ITEM%20NO.%20854%20Sanitary%20Sewer%20Laterals.pdf](https://apps.saws.org/business_center/specs/constspecs/docs/conspecs_2021/ITEM%20NO.%20854%20Sanitary%20Sewer%20Laterals.pdf)

Specification 804: Excavation, Trenching and Backfill

[https://apps.saws.org/business\\_center/specs/constspecs/docs/conspecs\\_2021/ITEM%20NO.%20804%20Excavation%20Trenching%20and%20Backfill.pdf](https://apps.saws.org/business_center/specs/constspecs/docs/conspecs_2021/ITEM%20NO.%20804%20Excavation%20Trenching%20and%20Backfill.pdf)

**PRE-CAST MANHOLE  
DRAWINGS &  
SPECIFICATIONS**

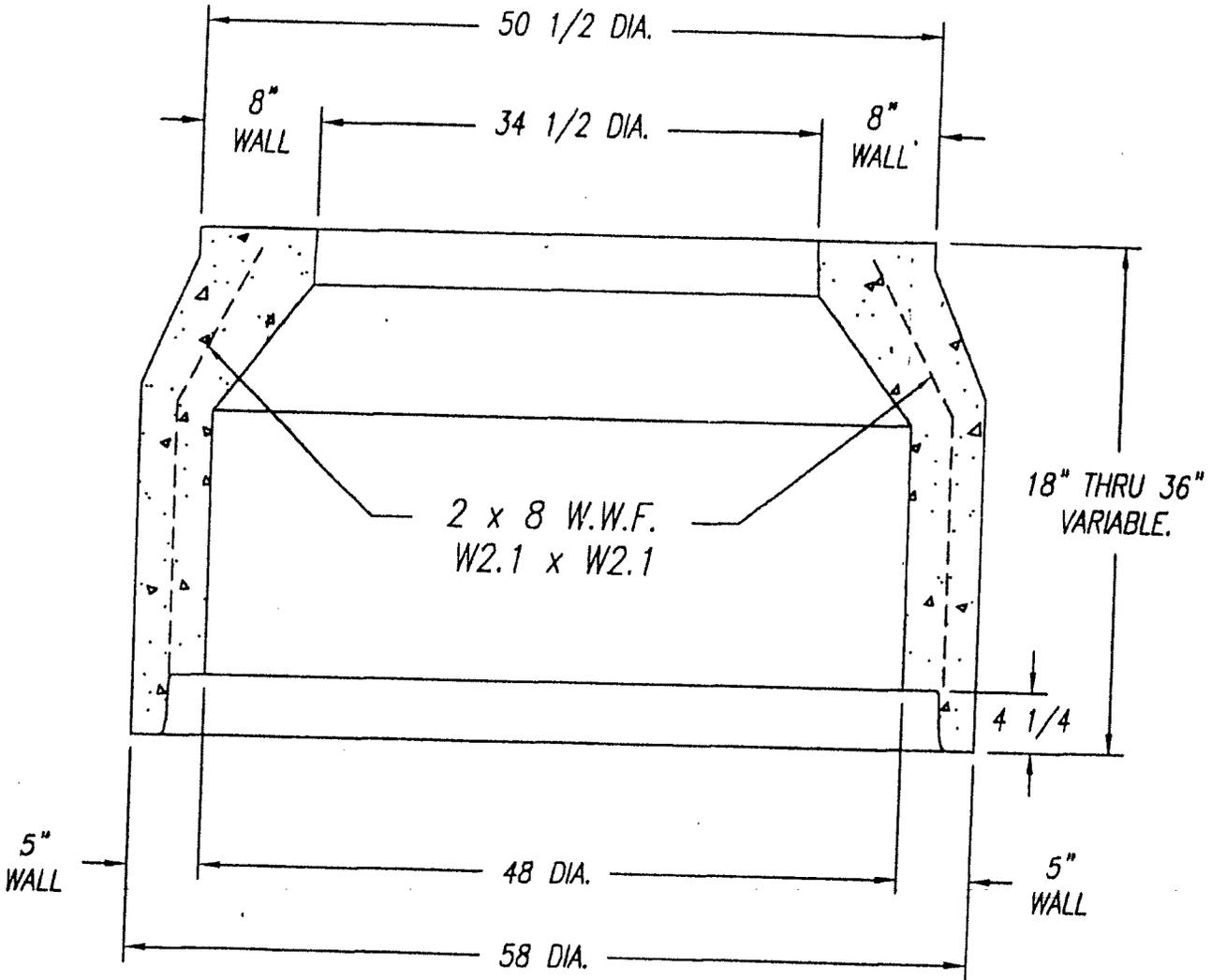

(7R JOINT)

REF. FORM DWG. 3-303-5561

		<p><b>QUINN</b>  <b>MACHINE &amp; FOUNDRY CORP.</b>          A MEMBER OF THE BESSER FAMILY OF COMPANIES          BOONE, IOWA U.S.A.</p>	
<p><small>THIS PRINT IS THE PROPERTY OF INTERNATIONAL PIPE MACHINERY CORP. IT IS CONFIDENTIAL AND NOT TO BE REPRODUCED WITHOUT OUR EXPRESS PERMISSION AND MUST BE RETURNED UPON REQUEST.</small></p>			
<p><b>CHARLOTTE</b></p>			
<p>48 x 5 x 34 1/2 x 8 x 36 &amp; 18          CONCENTRIC CONCRETE SECTION</p>			
DRAFTER	JJK	4/19/02	REV.
CHECKED			
<p>SCALE: 1/16" = 1"</p>			<p><b>CONCENTRIC</b></p>

# Precast Manholes

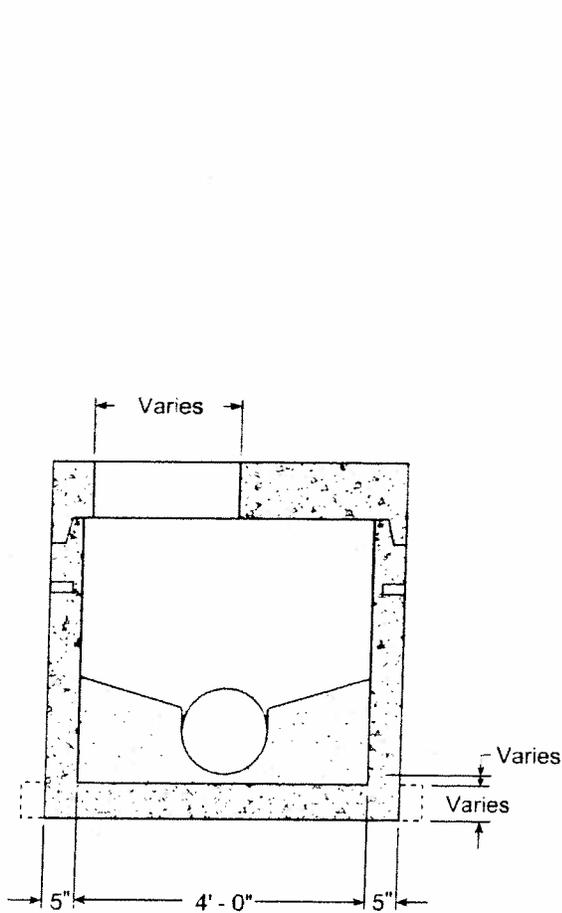

**Flattop Illustration**  
for Shallow Manhole

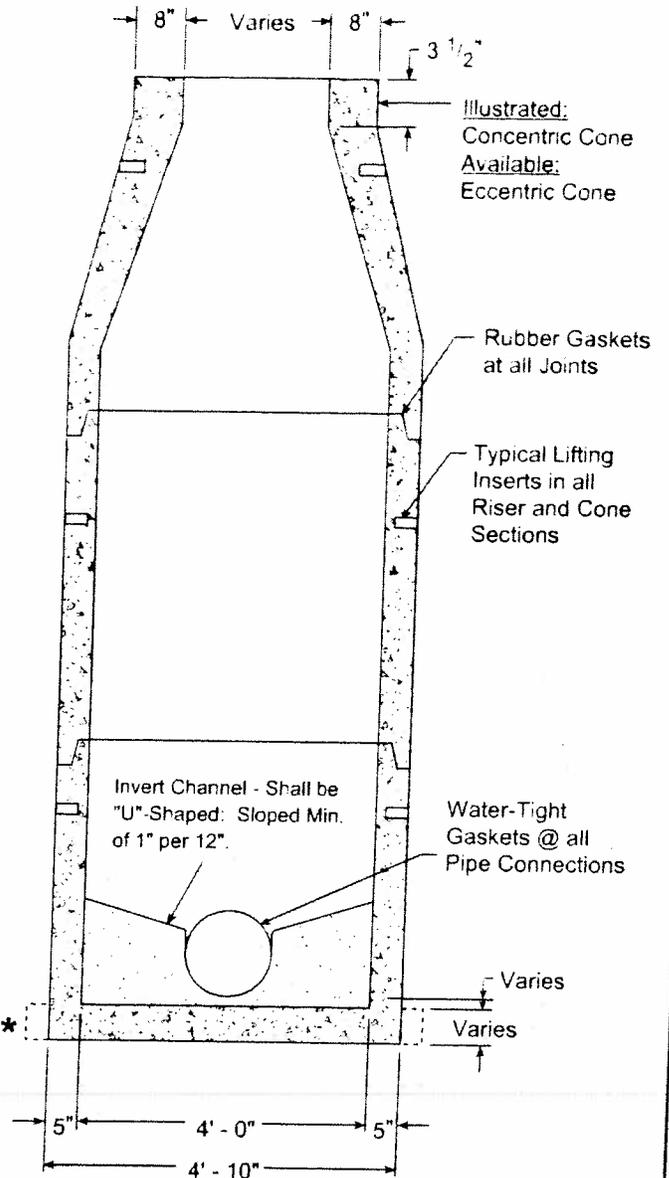

**Section View**  
4' I.D. Manhole - Regular Base  
with Reducing Cone

## Materials & Features

HOLES AS SPECIFIED: Max diameter = 32"  
 CONCRETE: 5,000 PSI, 28 day strength.  
 REINFORCING: Meets or exceeds ASTM C478 requirements.  
 Average weight of 24" depth base w/8" invert = 4,500 lbs.  
 Estimated weight of riser and cone sections = 870 lbs. / vt. ft.

\* - Extended base is available to meet local requirements.

In the event a boot is loose contact your Hanson representative to resolve.

*"Manufactured to your specifications."*

-No Scale-  
 All dimensions subject to allowable  
 specification tolerances.

TITLE	PLANT	STATE	SECTION, PAGE	DATE	
4' I.D. Manhole Regular Base w/Reducing Cone	All Plants	TX	5.5	08-15-06	

Contact Hanson

Go to Index

EXIT 

# Precast Manholes

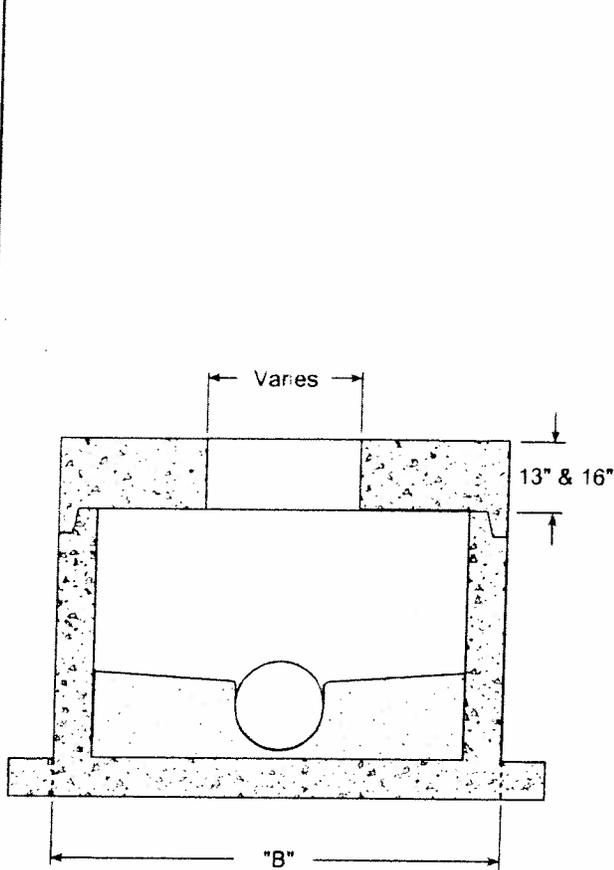

**Flattop Illustration**  
for Shallow Manhole

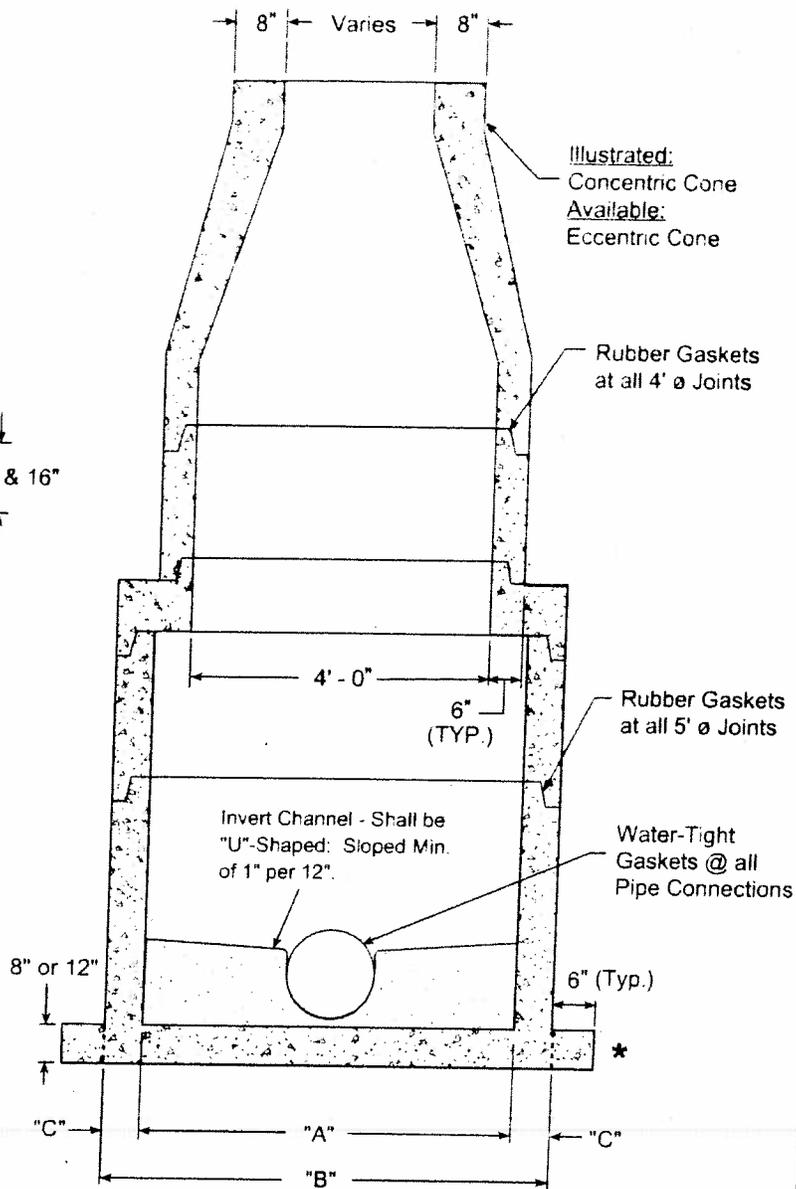

**Section View**  
5' / 4' & 6' / 4' I.D. Manhole  
Extended Base with Reducing Cone

## Materials & Features

HOLES AS SPECIFIED: for 5' I.D. max diameter = 40"  
for 6' I.D. max diameter = 54"

CONCRETE: 5,000 PSI, 28 day strength.

REINFORCING: Meets or exceeds ASTM C478 requirements.

Average weight of 24" depth base w/8" invert:

for 5' I.D. = 7,500 lbs.

for 6' I.D. = 10,600 lbs.

Estimated weight of riser and sections:

for 5' I.D. = 1,325 lbs. / vt. ft.

for 6' I.D. = 1,800 lbs. / vt. ft.

For pipe sizes 15" and larger, invert shall be equal to the larger pipe diameter.

\* - Extended base shown: Regular base also available."

In the event a boot is loose contact your Hanson representative to resolve.

*"Manufactured to your specifications."*

Pipe Size	I.D. "A"	O.D. "B"	Wall Thk. "C"
5'	5' - 0"	6' - 0"	6"
6'	6' - 0"	7' - 2"	7"

-No Scale-  
All dimensions subject to allowable specification tolerances.

TITLE

**5' / 4' & 6' / 4' I.D. Manhole**  
Extended Base w/Reducing Cone

PLANT

All Plants

STATE

TX

SECTION, PAGE

5.6

DATE

08-15-06

**Hanson**

Contact Hanson

Go to Index

EXIT

# Precast Manholes

For Pipe Entering the Manhole at Excessive Depths Above the Flow Line Out, the Contractor May be Responsible for Grout Work Necessary to Bring Channel up to Flow Line on Inlet Pipe.

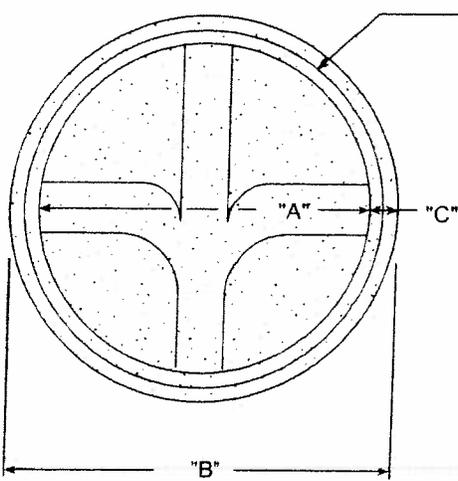
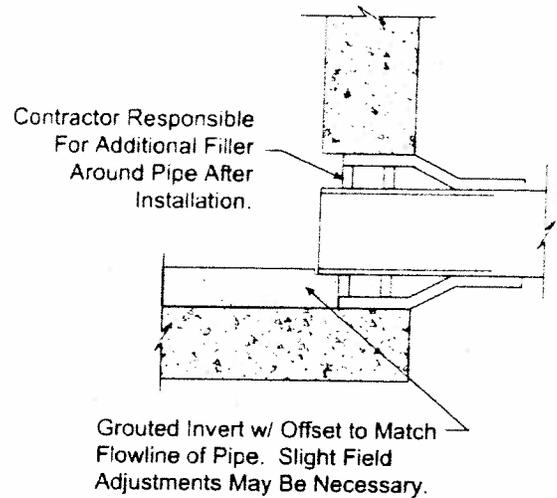

**Plan View**

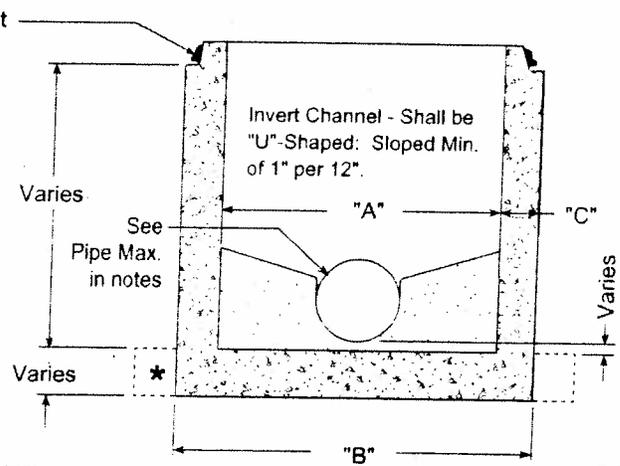

**Section View**

## Materials & Features

### HOLES AS SPECIFIED:

- For 4' I.D. max. diameter = 32"
- For 5' I.D. max. diameter = 40"
- For 6' I.D. max. diameter = 54"

CONCRETE: 5,000 PSI, 28 day strength

REINFORCING: Meets or exceeds ASTM C478 requirements.

Average weight of 24" depth base w/8" invert = 4,500 lbs

Water-tight gaskets at all pipe connections.

\* - Regular base shown; Extended base also available.

In the event a boot is loose contact your Hanson representative to resolve.

Pipe Size	I.D. "A"	O.D. "B"	Wall Thk. "C"
4'	4'-0"	4'-10"	5"
5'	5'-0"	6'-0"	6"
6'	6'-0"	7'-2"	7"

-No Scale-  
All dimensions subject to allowable specification tolerances.

TITLE	PLANT	STATE	SECTION/PAGE	DATE	
<b>Details: 4', 5' &amp; 6' I.D. Precast Regular Manhole Base</b>	All Plants	TX	5.7	08-15-06	

**Contact Hanson**

**Go to Index**

**EXIT**

**Precast Manholes**

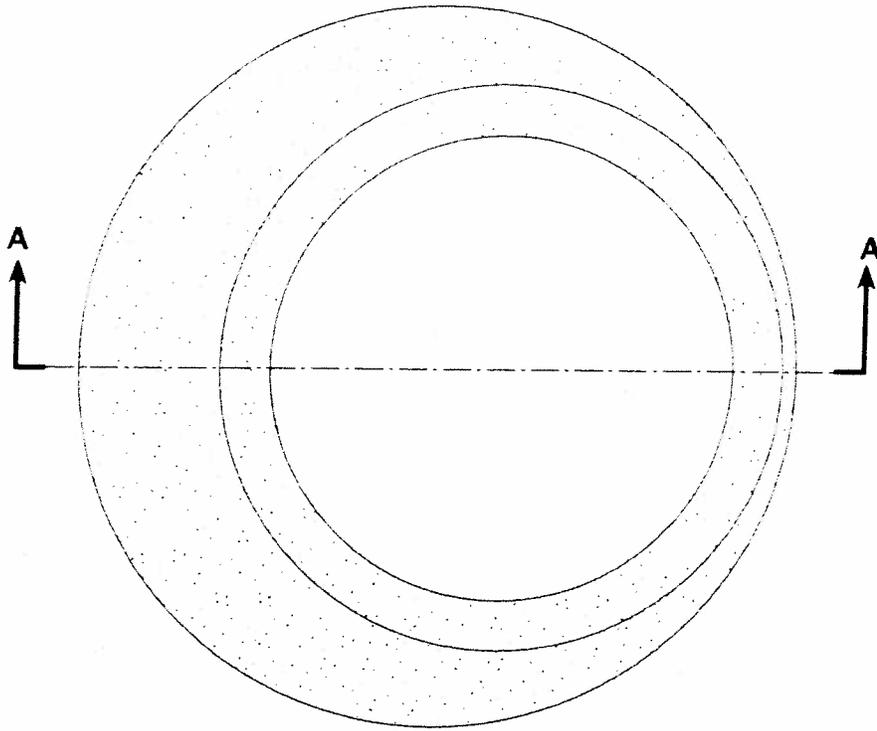

**Plan View**

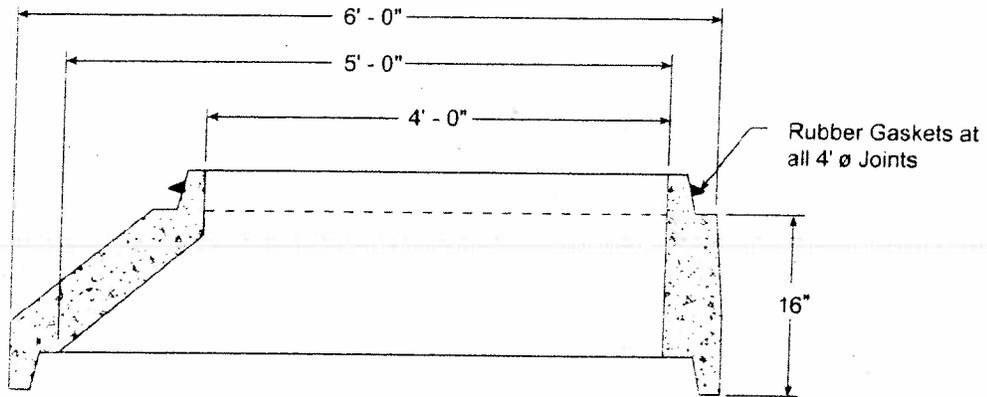

**Section View**

**Materials & Features**

CONCRETE: 5,000 PSI, 28 day strength.  
 REINFORCING: Meets or exceeds ASTM C478 requirements.  
 CONSTRUCTION OF PRECAST is in accordance with ASTM C478.  
 Concrete is poured according to ACI-500.

-No Scale-  
 All dimensions subject to allowable  
 specification tolerances.

TITLE	PLANT	STATE	SECTION/PAGE	DATE	
5' x 4' Conical Adaptor	Waco	TX	5 8	08-15-06	

**Contact Hanson**

**Go to Index**

**EXIT** 

# Precast Manholes

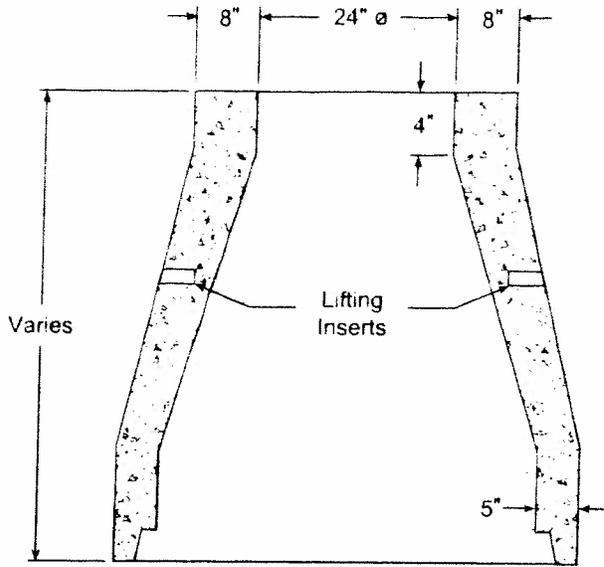

**Concentric Cone**  
24"  $\varnothing$  Opening

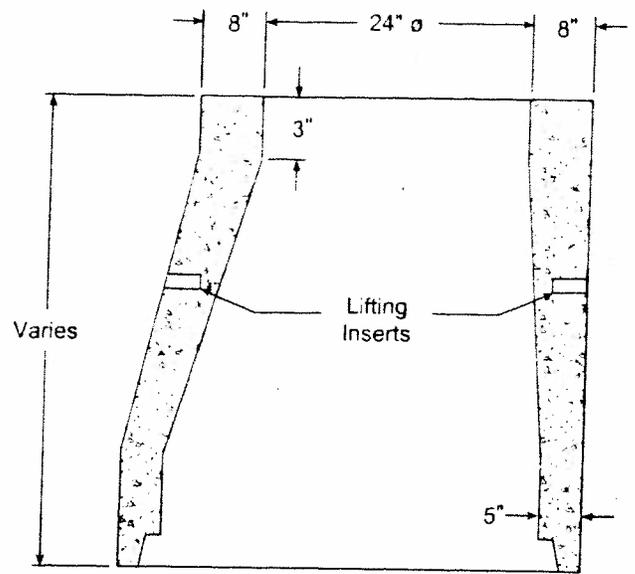

**Eccentric Cone**  
24"  $\varnothing$  Opening

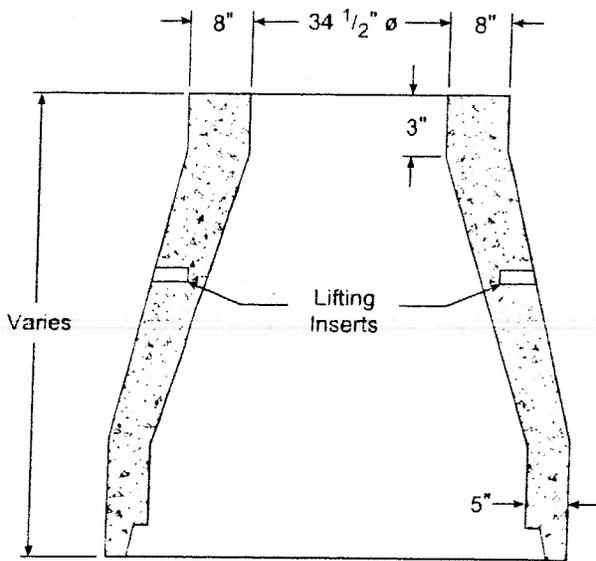

**Concentric Cone**  
34 1/2"  $\varnothing$  Opening

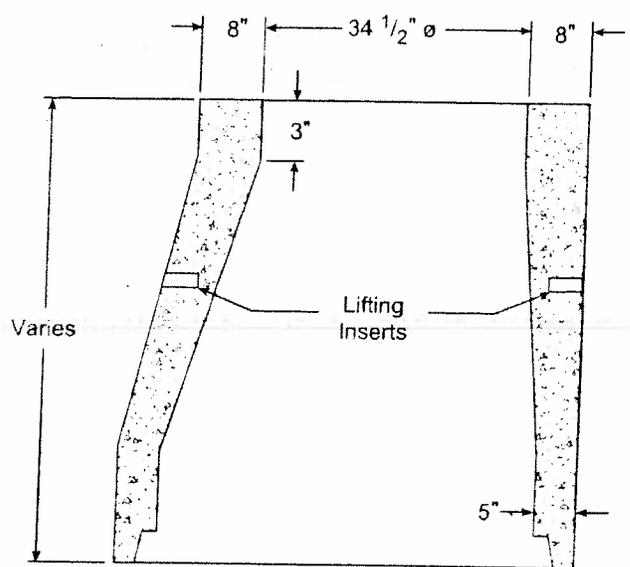

**Eccentric Cone**  
34 1/2"  $\varnothing$  Opening

## Materials & Features

CONCRETE: 5,000 PSI, 28 day strength.  
REINFORCING: Meets or exceeds ASTM C478 requirements.  
30"  $\varnothing$  also available in North Texas.

-No Scale-  
All dimensions subject to allowable specification tolerances.

TITLE	PLANT	STATE	SECTION/PAGE	DATE	
Hanson 48" Manhole Reducing Cone Detail	Waco Houston	TX	5.9	08-15-06	

Contact Hanson

Go to Index

EXIT 

# Precast Manholes

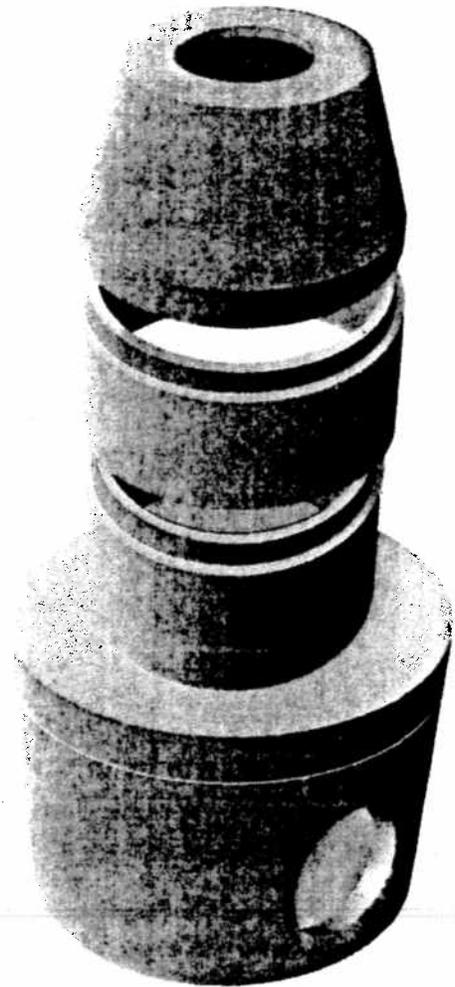
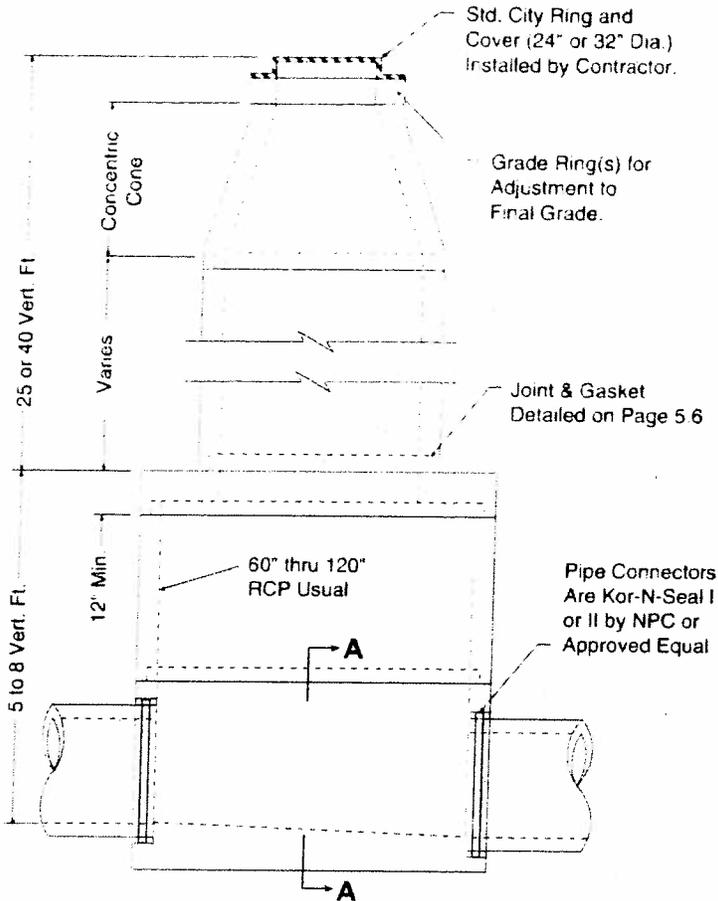

**Isometric View**

**w/ Precast Base**



**Section A-A**

**Base Slab Reinforcing**

**30' Deep Structure**

- 60"ø - 6" Thick Slab min. - #5 @ 8" ea.way
- 72"ø - 8" Thick Slab min. - #5 @ 8" ea.way
- 84"ø - 8" Thick Slab min. - #5 @ 6" ea.way
- 96"ø - 10" Thick Slab min. - #5 @ 6" ea.way

**45' Deep Structure**

- 60"ø - 8" Thick Slab min. - #5 @ 8" ea.way
- 72"ø - 8" Thick Slab min. - #5 @ 8" ea.way
- 84"ø - 10" Thick Slab min. - #5 @ 6" ea.way
- 96"ø - 12" Thick Slab min. - #5 @ 6" ea.way

All Reinforcing has 1 1/2" cover from top of slab.

**Materials & Features**

CONCRETE: 5,000 PSI in 28 days.  
 REINFORCING STEEL, per ASTM A-615, Grade 60.  
 REINFORCING to meet AASHTO HS 20-44 Loading.  
 DESIGN EQUAL TO OR EXCEEDS ASTM C-478  
 In the event a boot is loose contact your Hanson representative to resolve.

**Note:**

- Inverts shall be specifically sized for connecting pipes; and shall be U-Shaped with the min. depth 3/4 of the largest pipe diameter.

-No Scale-  
 All dimensions subject to allowable specification tolerances.

TITLE	PLANT	STATE	SECTION, PAGE	DATE
30 & 45 Ft. Depth 60" thru 96" Large Base Manhole	Houston San Antonio	TX	5.10	08-15-06



**Contact Hanson**

**Go to Index**



# Precast Manholes

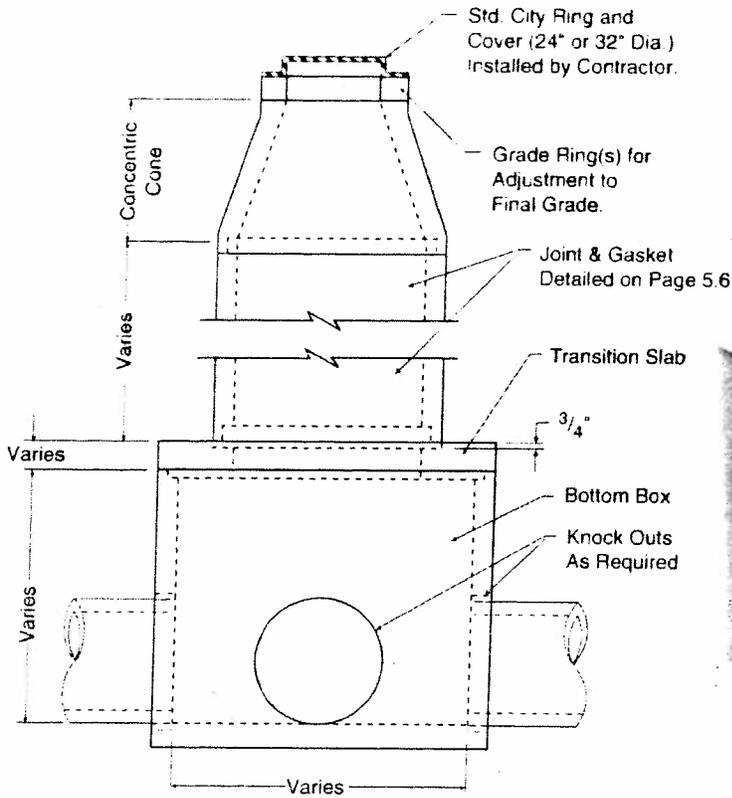

**Side View**

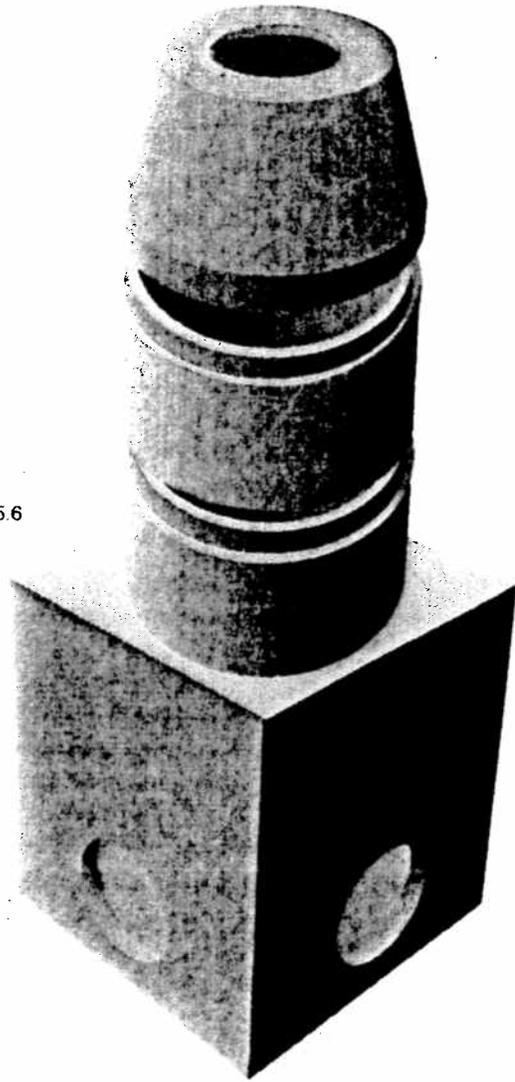

**Isometric View**

## Materials & Features

CONCRETE: 5,000 PSI in 28 days.

REINFORCING STEEL: per ASTM A-615 / A-185

REINFORCING to meet AASHTO HS 20-44 Loading.

BASE DESIGN EQUAL TO OR EXCEEDS ASTM C-357

RISER DESIGN EQUAL TO OR EXCEEDS ASTM C-478

In the event a boot is loose contact your Hanson representative to resolve.

**-No Scale-**  
All dimensions subject to allowable specification tolerances.

TITLE	PLANT	STATE	SECTION/PAGE	DATE
Type "C" Manhole	Houston San Antonio	TX	5.11	08-15-06



**Contact Hanson**

**Go to Index**

**EXIT**

# Precast Manholes

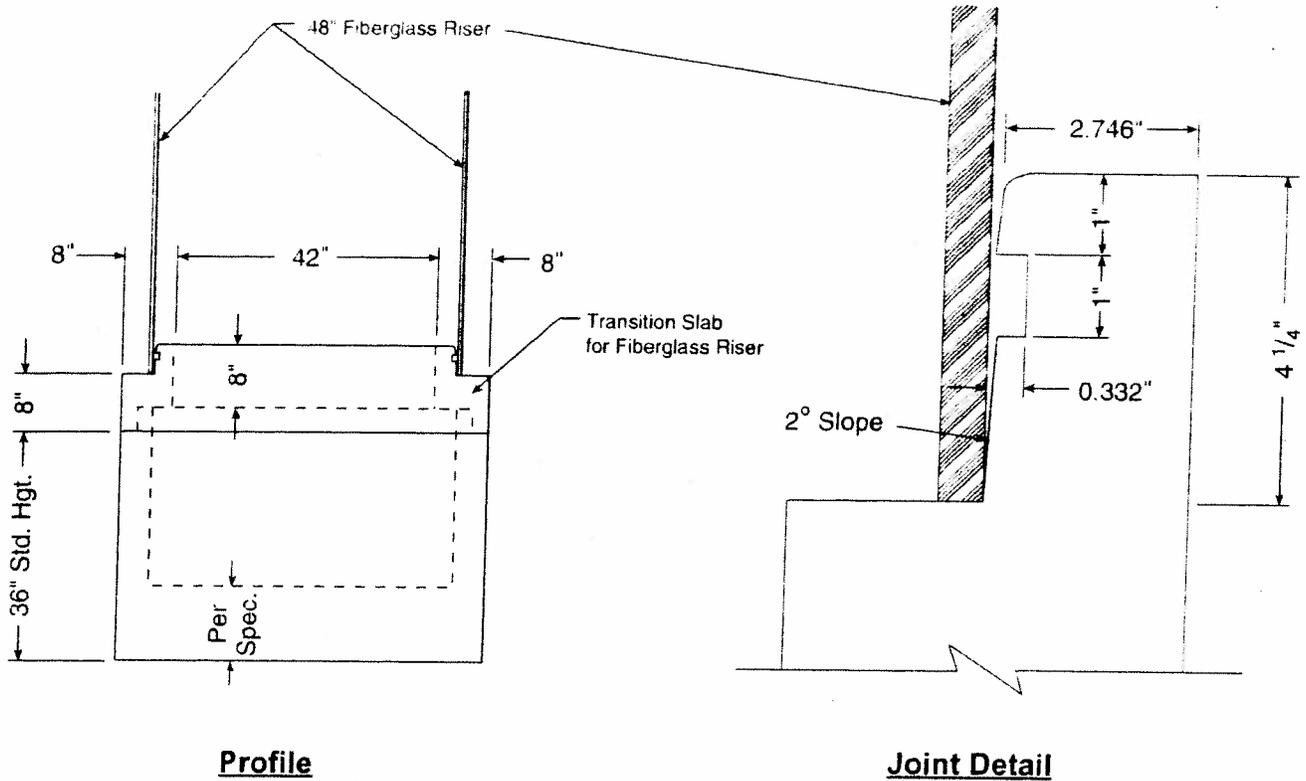

## Materials & Features

CONCRETE: 5,000 PSI in 28 days.  
 REINFORCING STEEL: per ASTM A-615, Grade 60.  
 REINFORCING to meet AASHTO HS 20-44 Loading.  
 DESIGN EQUAL TO OR EXCEEDS ASTM C-478

-No Scale-  
 All dimensions subject to allowable specification tolerances.

TITLE	PLANT	STATE	SECTION, PAGE	DATE	
ASTM C-478 Special Base	Houston	TX	5.12	08-15-06	

Contact Hanson

Go to Index

EXIT

# Precast Manholes

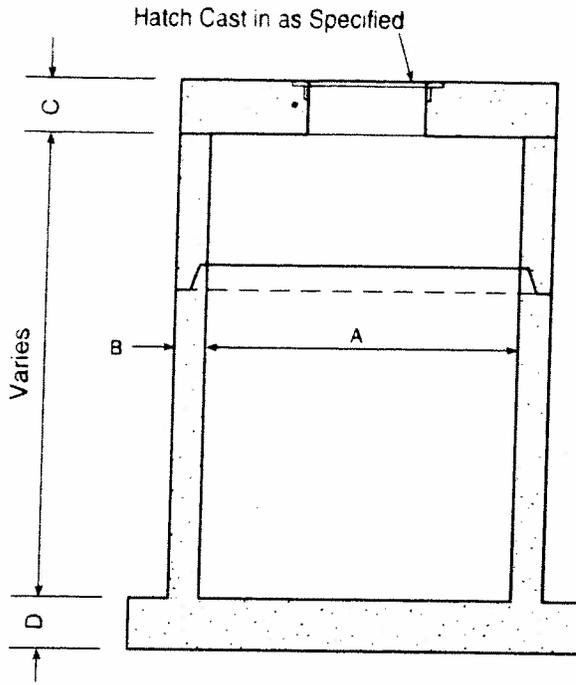

**Section View**

(Base configuration for 60", 72" & 84")

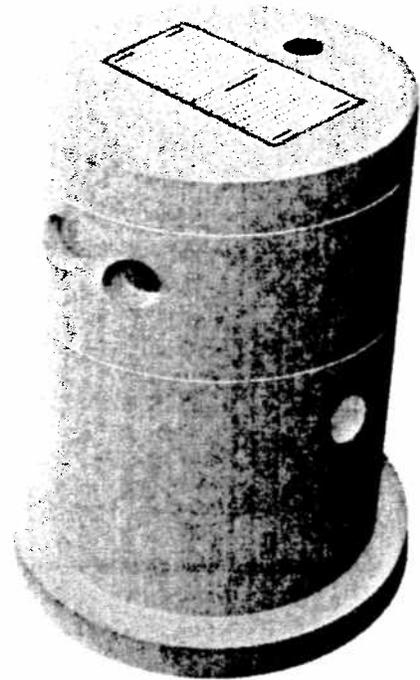

**Isometric View**

Product Dimensions				
A	B	C	D	
60"				Contact your local Hanson representative for product dimensions.
72"				
84"				
96"				
108"				
120"				
132"				
144"				

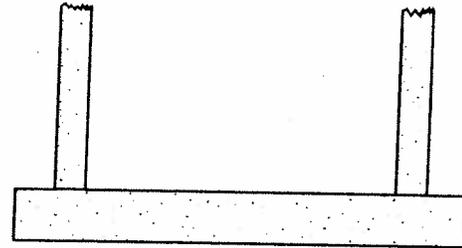

**Section View**

Base configuration for 96"

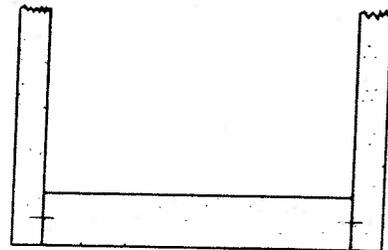

**Section View**

Base configuration for 108"-144"

## Materials & Features

CONCRETE: 5,000 PSI in 28 days.

REINFORCING STEEL: per ASTM A-615 / A-185

REINFORCING to meet AASHTO HS 20-44 Loading.

BASE DESIGN EQUAL TO OR EXCEEDS ASTM C-357

RISER DESIGN EQUAL TO OR EXCEEDS ASTM C-478

(A). Hatches as specified by Engineer.

In the event a boot is loose contact your Hanson representative to resolve.

-No Scale-

All dimensions subject to allowable specification tolerances.

TITLE	PLANT	STATE	SECTION, PAGE	DATE	
Typical Wetwells - Various Diameters	All Plants	TX	5.13	08-15-06	

**Contact Hanson**

**Go to Index**

**EXIT**

①

### "O"-Ring Gasket

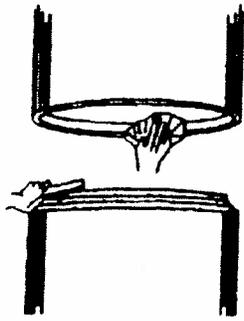

Carefully clean all dirt & foreign objects from the joining surface of the bell or groove end of pipe.

Carefully clean spigot or tongue end of pipe, including the gasket recess. Inspect the bell and spigot ends of each section to make sure they are free from cracks, chips or voids that will interfere with gasket.

Improperly prepared bell and spigot surfaces may prevent homing of the pipe or keep the gasket from sealing.

②



Lubricate bell joint surface liberally, covering entire inside surface using proper pipe gasket lubricant.

③



Lubricate the gasket thoroughly before it is placed on the spigot or tongue.

Bell and Gasket not lubricated or improperly lubricated may cause the gasket to roll and leak or possibly damage the bell.

④



#### \*\*IMPORTANT\*\*

Fit the gasket carefully, equalizing the rubber gasket stretch by running a smooth, round object (inserted between the gasket & spigot) around the entire circumference several times.

Unequal stretch could cause bunching of the gasket and may cause leaks in the joint or crack the bell.

⑤

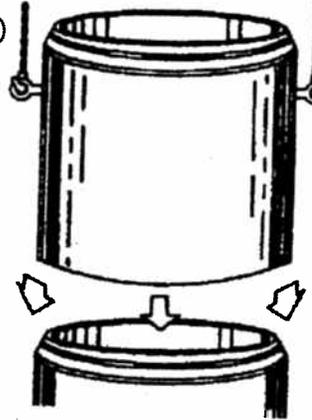

Align the bell & spigot to be joined. Before homing the joint, check that the gasket is in contact with the bell end entrance taper around the entire circumference.

Do not force sections together. If sections do not seat properly, unstack and contact your Hanson Sales Representative.

Improper alignment can dislodge gasket, causing leaks or possibly breaking the bell.

### Profile Gasket

1. Manhole sections should be handled with extreme caution to avoid chipping of the bell or spigot ends. Proper lifting devices must be used on all sections.
2. Inspect gasket sealing area for any voids or rough edges that may interfere with the seal.
3. Place the 4-G Gasket in the step of the spigot. (Making sure that the pointed end of the gasket is toward the end of the pipe as shown in Fig A.)
4. **\*\*IMPORTANT\*\*** Equalize the stretch on the gasket by pulling the sealing lube away from the spigot at least one inch and then releasing the gasket. Repeat this every three or four inches around the circumference of the pipe. Equalization of stretch makes sure that the gasket has the same stretched cross-section and tension throughout. **\*\*Do not lube the gasket or spigot end of the pipe.\*\***
5. Remove all dirt and other foreign matter from the inside surface of the bell. Apply lube to the inner surface of the bell including the

lead-in taper surface on the outer edge of the bell. Align spigot with the bell. Gasket should touch lead-in taper around the entire circumference before pushing the pipe home.

6. Push the manhole section carefully, until the spigot is all the way home. (Fig B) Do not force sections together. If sections do not seat properly, unstack and contact your Hanson Sales Representative.
7. Every manhole will not come home exactly the same. Differences in application, consistency of lubricants, dimensions in the spigot and groove will cause variations in installation. If joining problems arise, please contact the manhole manufacturer immediately rather than forcing manhole sections together with subsequent damage to the manhole.
8. All testing should be performed prior to backfill of the manhole. Problems can not be detected after the manhole is backfilled. **Testing the manhole after backfill voids all warranties.**



Fig. A

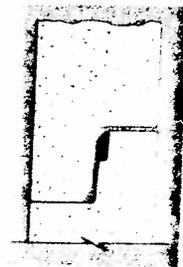

Fig. B

**Note:** Manholes in excess of 30' in depth must be vacuum tested prior to backfill. The loads presented by soils and possible groundwater at 30' in addition to the load from the vacuum may exceed the design capacity of the pipe to manhole connector.

TITLE	PLANT	STATE	SECTION, PAGE	DATE	
O-Ring & Profile Gasket Installation on Manholes	All Plants	TX	5.14	08-15-06	

Contact Hanson

Go to Index

EXIT

# Precast Manholes

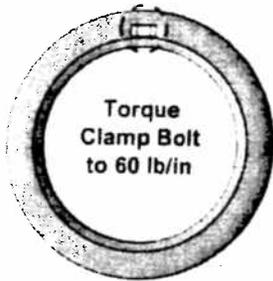

**Single Clamp**

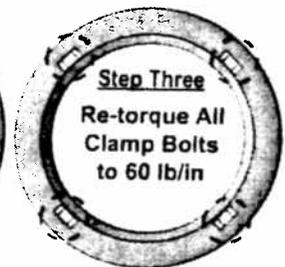
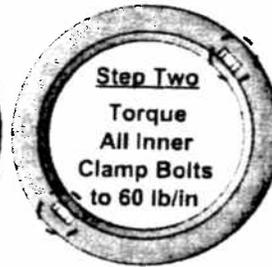
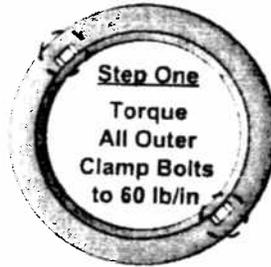

**Multiple Clamps**

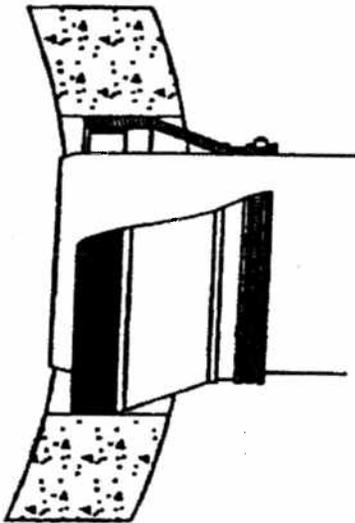

## Instructions

1. Clean pipe and boot to ensure no dirt or foreign materials are present.
2. Clamping surface on pipe must be clean and smooth.
3. Center pipe in opening and insert until pipe is at least equal to the inside plane of the manhole.
4. Attach take-up clamps(s) and stagger screw(s) of clamps(s) around the groove of the gasket so that take-up pressure will be equalized. Make sure each clamp is completely in the correct groove.
5. Using a torque ratchet or torque wrench, gradually tighten all screw(s) of clamp(s) in an alternating pattern to 60 lbs/in torque.
6. After reaching 60 lbs/in torque on final screw, check all screws again to ensure equal compression of all clamps.
7. If system is to be tested, testing shall be completed prior to backfilling, following all recommendations and requirements of the test system manufacturer. Vacuum testing shall be conducted in accordance with ASTM C-1244.
8. Adjust pipe to line and grade. Use proper bedding, backfill materials and techniques so that pipe deflection and deformation is minimized.
9. Any pipe stubs installed in the manhole must be positively restrained from movement.
10. Vacuum testing after backfill voids warranty.

**For more information contact your local Hanson Representative.**

TITLE	PLANT	STATE	SECTION, PAGE	DATE
Pipe to Manhole Connector Installation Guide	All Plants	TX	5.15	08-15-06



**Contact Hanson**

**Go to Index**

**EXIT**

**CONCRETE 4000 PSI  
REINF 60000 PSI  
HS 20 LOADING**

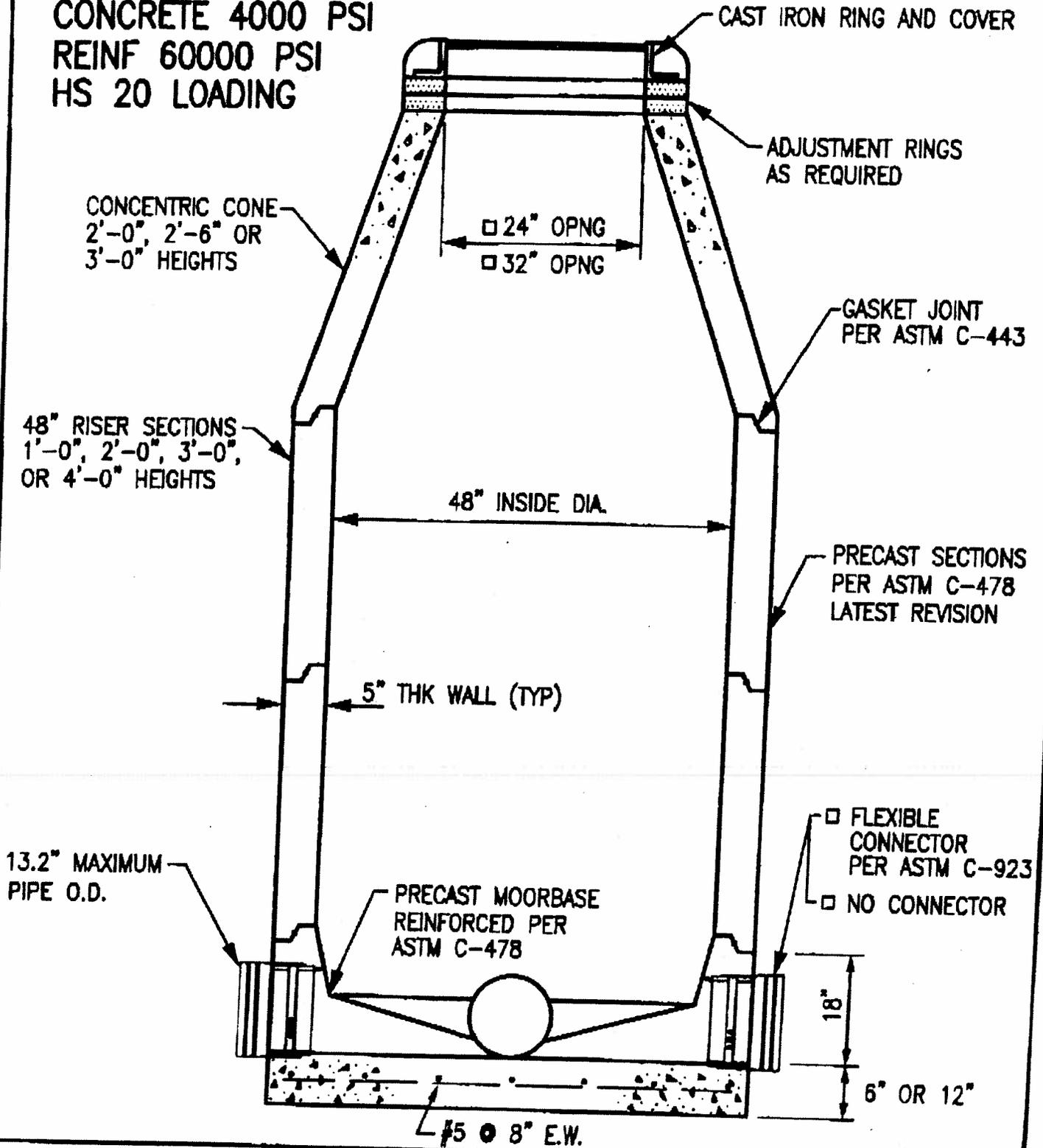

**Rinker**  
MATERIALS  
**Moor-Tex**

2735 HWY. 36 NORTH  
MAILING: P.O. BOX 1088  
SEALY, TEXAS 77474  
PH: (979) 885-7403  
(281) 375-6121  
FAX: (979) 885-7001

REV.	DESCRIPTION	DATE
DATE: 8-09-02	SCALE: 3/4"=1'-0"	BY: RB
<b>48" PRECAST CONCENTRIC MANHOLE WITH MOORBASE</b>		
JOB: 2002	FILE: 48CM	DWG. NO. 48CM

**TEMPORARY STORMWATER  
SECTION (TCEQ-0602)**

# Temporary Stormwater Section

## Texas Commission on Environmental Quality

for Regulated Activities on the Edwards Aquifer Recharge Zone and Relating to 30 TAC §213.5(b)(4)(A), (B), (D)(I) and (G); Effective June 1, 1999

**To ensure that the application is administratively complete, confirm that all fields in the form are complete, verify that all requested information is provided, consistently reference the same site and contact person in all forms in the application, and ensure forms are signed by the appropriate party.**

**Note: Including all the information requested in the form and attachments contributes to more streamlined technical reviews.**

## Signature

To the best of my knowledge, the responses to this form accurately reflect all information requested concerning the proposed regulated activities and methods to protect the Edwards Aquifer. This **Temporary Stormwater Section** is hereby submitted for TCEQ review and executive director approval. The application was prepared by:

Print Name of Customer/Agent: Andrew Belton, P.E.

Date: 4/10/24

Signature of Customer/Agent:



Regulated Entity Name: Teralta Phase II

## Project Information

### Potential Sources of Contamination

*Examples: Fuel storage and use, chemical storage and use, use of asphaltic products, construction vehicles tracking onto public roads, and existing solid waste.*

1. Fuels for construction equipment and hazardous substances which will be used during construction:

The following fuels and/or hazardous substances will be stored on the site: construction staging area

These fuels and/or hazardous substances will be stored in:

- Aboveground storage tanks with a cumulative storage capacity of less than 250 gallons will be stored on the site for less than one (1) year.

- Aboveground storage tanks with a cumulative storage capacity between 250 gallons and 499 gallons will be stored on the site for less than one (1) year.
  - Aboveground storage tanks with a cumulative storage capacity of 500 gallons or more will be stored on the site. An Aboveground Storage Tank Facility Plan application must be submitted to the appropriate regional office of the TCEQ prior to moving the tanks onto the project.
  - Fuels and hazardous substances will not be stored on the site.
2.  **Attachment A - Spill Response Actions.** A site specific description of the measures to be taken to contain any spill of hydrocarbons or hazardous substances is attached.
  3.  Temporary aboveground storage tank systems of 250 gallons or more cumulative storage capacity must be located a minimum horizontal distance of 150 feet from any domestic, industrial, irrigation, or public water supply well, or other sensitive feature.
  4.  **Attachment B - Potential Sources of Contamination.** A description of any activities or processes which may be a potential source of contamination affecting surface water quality is attached.

### ***Sequence of Construction***

5.  **Attachment C - Sequence of Major Activities.** A description of the sequence of major activities which will disturb soils for major portions of the site (grubbing, excavation, grading, utilities, and infrastructure installation) is attached.
  - For each activity described, an estimate (in acres) of the total area of the site to be disturbed by each activity is given.
  - For each activity described, include a description of appropriate temporary control measures and the general timing (or sequence) during the construction process that the measures will be implemented.
6.  Name the receiving water(s) at or near the site which will be disturbed or which will receive discharges from disturbed areas of the project: Upper San Antonio River

### ***Temporary Best Management Practices (TBMPs)***

*Erosion control examples: tree protection, interceptor swales, level spreaders, outlet stabilization, blankets or matting, mulch, and sod. Sediment control examples: stabilized construction exit, silt fence, filter dikes, rock berms, buffer strips, sediment traps, and sediment basins. Please refer to the Technical Guidance Manual for guidelines and specifications. All structural BMPs must be shown on the site plan.*

7.  **Attachment D – Temporary Best Management Practices and Measures.** TBMPs and measures will prevent pollution of surface water, groundwater, and stormwater. The construction-phase BMPs for erosion and sediment controls have been designed to retain sediment on site to the extent practicable. The following information is attached:

- A description of how BMPs and measures will prevent pollution of surface water, groundwater or stormwater that originates upgradient from the site and flows across the site.
  - A description of how BMPs and measures will prevent pollution of surface water or groundwater that originates on-site or flows off site, including pollution caused by contaminated stormwater runoff from the site.
  - A description of how BMPs and measures will prevent pollutants from entering surface streams, sensitive features, or the aquifer.
  - A description of how, to the maximum extent practicable, BMPs and measures will maintain flow to naturally-occurring sensitive features identified in either the geologic assessment, TCEQ inspections, or during excavation, blasting, or construction.
8.  The temporary sealing of a naturally-occurring sensitive feature which accepts recharge to the Edwards Aquifer as a temporary pollution abatement measure during active construction should be avoided.
- Attachment E - Request to Temporarily Seal a Feature.** A request to temporarily seal a feature is attached. The request includes justification as to why no reasonable and practicable alternative exists for each feature.
  - There will be no temporary sealing of naturally-occurring sensitive features on the site.
9.  **Attachment F - Structural Practices.** A description of the structural practices that will be used to divert flows away from exposed soils, to store flows, or to otherwise limit runoff discharge of pollutants from exposed areas of the site is attached. Placement of structural practices in floodplains has been avoided.
10.  **Attachment G - Drainage Area Map.** A drainage area map supporting the following requirements is attached:
- For areas that will have more than 10 acres within a common drainage area disturbed at one time, a sediment basin will be provided.
  - For areas that will have more than 10 acres within a common drainage area disturbed at one time, a smaller sediment basin and/or sediment trap(s) will be used.
  - For areas that will have more than 10 acres within a common drainage area disturbed at one time, a sediment basin or other equivalent controls are not attainable, but other TBMPs and measures will be used in combination to protect down slope and side slope boundaries of the construction area.
  - There are no areas greater than 10 acres within a common drainage area that will be disturbed at one time. A smaller sediment basin and/or sediment trap(s) will be used in combination with other erosion and sediment controls within each disturbed drainage area.

- There are no areas greater than 10 acres within a common drainage area that will be disturbed at one time. Erosion and sediment controls other than sediment basins or sediment traps within each disturbed drainage area will be used.
11.  **Attachment H - Temporary Sediment Pond(s) Plans and Calculations.** Temporary sediment pond or basin construction plans and design calculations for a proposed temporary BMP or measure have been prepared by or under the direct supervision of a Texas Licensed Professional Engineer. All construction plans and design information must be signed, sealed, and dated by the Texas Licensed Professional Engineer. Construction plans for the proposed temporary BMPs and measures are attached.
- N/A
12.  **Attachment I - Inspection and Maintenance for BMPs.** A plan for the inspection of each temporary BMP(s) and measure(s) and for their timely maintenance, repairs, and, if necessary, retrofit is attached. A description of the documentation procedures, recordkeeping practices, and inspection frequency are included in the plan and are specific to the site and/or BMP.
13.  All control measures must be properly selected, installed, and maintained in accordance with the manufacturer's specifications and good engineering practices. If periodic inspections by the applicant or the executive director, or other information indicate a control has been used inappropriately, or incorrectly, the applicant must replace or modify the control for site situations.
14.  If sediment escapes the construction site, off-site accumulations of sediment must be removed at a frequency sufficient to minimize offsite impacts to water quality (e.g., fugitive sediment in street being washed into surface streams or sensitive features by the next rain).
15.  Sediment must be removed from sediment traps or sedimentation ponds not later than when design capacity has been reduced by 50%. A permanent stake will be provided that can indicate when the sediment occupies 50% of the basin volume.
16.  Litter, construction debris, and construction chemicals exposed to stormwater shall be prevented from becoming a pollutant source for stormwater discharges (e.g., screening outfalls, picked up daily).

### ***Soil Stabilization Practices***

*Examples: establishment of temporary vegetation, establishment of permanent vegetation, mulching, geotextiles, sod stabilization, vegetative buffer strips, protection of trees, or preservation of mature vegetation.*

17.  **Attachment J - Schedule of Interim and Permanent Soil Stabilization Practices.** A schedule of the interim and permanent soil stabilization practices for the site is attached.

18.  Records must be kept at the site of the dates when major grading activities occur, the dates when construction activities temporarily or permanently cease on a portion of the site, and the dates when stabilization measures are initiated.
19.  Stabilization practices must be initiated as soon as practicable where construction activities have temporarily or permanently ceased.

### ***Administrative Information***

20.  All structural controls will be inspected and maintained according to the submitted and approved operation and maintenance plan for the project.
21.  If any geologic or manmade features, such as caves, faults, sinkholes, etc., are discovered, all regulated activities near the feature will be immediately suspended. The appropriate TCEQ Regional Office shall be immediately notified. Regulated activities must cease and not continue until the TCEQ has reviewed and approved the methods proposed to protect the aquifer from any adverse impacts.
22.  Silt fences, diversion berms, and other temporary erosion and sediment controls will be constructed and maintained as appropriate to prevent pollutants from entering sensitive features discovered during construction.

**ATTACHMENT A**

## TERALTA PHASE II

### Water Pollution Abatement Plan Modification

#### Attachment A – Spill Response Actions

In the event of an accidental leak or spill:

- Spill must be contained and cleaned up immediately.
- Spills will not be merely buried or washed with water.
- Contractor shall take action to contain spill. Contractor may use sand or other absorbent material stockpiled on site to absorb spill. Absorbent material should be spread over the spill area to absorb the spilled product.
- In the event of an uncontained discharge the contractor shall utilize onsite equipment to construct berms downgradient of the spill with sand or other absorbent material to contain and absorb the spilled product.
- Spill containment/absorbent materials along with impacted media must be collected and stored in such a way so as not to continue to affect additional media (soil/water). Once the spill has been contained, collected material should be placed on poly or plastic sheeting until removed from the site. The impacted media and cleanup materials should be covered with plastic sheeting and the edges weighed down with paving bricks or other similarly dense objects as the material is being accumulated. This will prevent the impacted media and cleanup materials from becoming airborne in windy conditions or impacting runoff during a rain event. The stockpiled materials should not be located within an area of concentrated runoff such as along a curb line or within a swale.
- Contaminated soils and cleanup materials will be sampled for waste characterization. When the analysis results are known the contaminated soils and cleanup materials will be removed from the site and disposed in a permitted landfill in accordance with applicable regulations.
- The contractor will be required to notify the owner, who will in turn contact TCEQ to notify them in the event of a significant hazardous/reportable quantity spill. Additional notifications as required by the type and amount of spill will be conducted by owner or owner's representative.

In the event of an accidental significant or hazardous spill:

The contractor will be required to report significant or hazardous spills in reportable quantities to:

- Notify the TCEQ by telephone as soon as possible and within 24 hours at 512-339-2929 (Austin) or 210-490-3096 (San Antonio) between 8 AM and 5 PM. After hours, contact the Environmental Release Hotline at 1-800-832-8224. It is the contractor's responsibility to have all emergency phone numbers at the construction site. [https://www.tceq.texas.gov/response/spills/spill\\_rq.html](https://www.tceq.texas.gov/response/spills/spill_rq.html)
- For spills of federal reportable quantities, in conformance with the requirements in 40 CFR parts 110,119, and 302, the contractor should notify the National Response Center at (800) 424-8802.

## TERALTA PHASE II

### Water Pollution Abatement Plan Modification

- Notification should first be made by telephone and followed up with a written report.
- The services of a spills contractor or a Haz-Mat team should be obtained immediately. Construction personnel should not attempt to clean up until the appropriate and qualified staffs have arrived at the job site.
- Other agencies which may need to be consulted include, but are not limited to, the City Police Department, County Sheriff Office, Fire Departments, etc.
- Contaminated soils will be sampled for waste characterization. When the analysis results are known the contaminated soils will be removed from the site and disposed in a permitted landfill in accordance with applicable regulations.

Additional guidance can be obtained from TCEQ's Technical Guidance Manual (TGM) RG-348 (2005) Section 1.4.16. Contractor shall review this section.

**ATTACHMENT B**

# TERALTA PHASE II

## Water Pollution Abatement Plan Modification

### Attachment B – Potential Sources of Contamination

Other potential sources of contamination during construction include:

- |                      |   |  |
|----------------------|---|--|
| Potential Source     | ● | Asphalt products used on this project.   |
| Preventative Measure | ■ | After placement of asphalt, emulsion or coatings, the contractor will be responsible for immediate cleanup should an unexpected rain occur. For the duration of the asphalt product curing time, the contractor will maintain standby personnel and equipment to contain any asphalt wash-off should an unexpected rain occur. The contractor will be instructed not to place asphalt products on the ground within 48 hours of a forecasted rain. |
| Potential Source     | ● | Oil, grease, fuel and hydraulic fluid contamination from construction equipment and vehicle dripping.  |
| Preventative Measure | ■ | Vehicle maintenance when possible will be performed within the construction staging area.  |
|                      | ■ | Construction vehicles and equipment shall be checked regularly for leaks and repaired immediately.   |
| Potential Source     | ● | Accidental leaks or spills of oil, petroleum products and substances listed under 40 CFR parts 110, 117, and 302 used or stored temporarily on site.   |
| Preventative Measure | ■ | Contractor to incorporate into regular safety meetings, a discussion of spill prevention and appropriate disposal procedures.  |
|                      | ■ | Contractor's superintendent or representative overseer shall enforce proper spill prevention and control measures.   |
|                      | ■ | Hazardous materials and wastes shall be stored in covered containers and protected from vandalism.   |
|                      | ■ | A stockpile of spill cleanup materials shall be stored on site where it will be readily accessible.  |
| Potential Source     | ● | Miscellaneous trash and litter from construction workers and material wrappings.   |
| Preventive Measure   | ■ | Trash containers will be placed throughout the site to encourage proper trash disposal.  |
| Potential Source     | ● | Construction debris.   |
| Preventive Measure   | ■ | Construction debris will be monitored daily by contractor. Debris will be collected weekly and placed in disposal bins. Situations requiring immediate attention will be addressed on a case by case basis.  |

## TERALTA PHASE II

### Water Pollution Abatement Plan Modification

- |                      |   |   |
|----------------------|---|---|
| Potential Source     | ● | Spills/Overflow of waste from portable toilets  |
| Preventative Measure | ■ | Portable toilets will be placed away from high traffic vehicular areas and storm drain inlets.  |
|                      | ■ | Portable toilets will be placed on a level ground surface.  |
|                      | ■ | Portable toilets will be inspected regularly for leaks and will be serviced and sanitized at time intervals that will maintain sanitary conditions. |

**ATTACHMENT C**

## TERALTA PHASE II

### Water Pollution Abatement Plan Modification

#### Attachment C – Sequence of Major Activities

The sequence of major activities which disturb soil during construction on this site will be divided into two stages. The first is site preparation that will include installation of TBMPs, clearing and grubbing of vegetation where applicable. This will disturb approximately 6.23 acres. The second is construction that will include construction of commercial buildings, parking, and drives, landscaping and site cleanup. Proposed activities for the Sewage Collection System include excavation, installation of the sewer mains, backfill, and compaction. Approximately 0.36 acres may be disturbed as identified by the 50-foot envelope shown on the plans; however, an overall 6.23 acres will be disturbed for this phase of development.

**ATTACHMENT D**

## TERALTA PHASE II

### Water Pollution Abatement Plan Modification

#### Attachment D – Temporary Best Management Practices and Measures

A description of how BMPs and measures will prevent pollution of surface water, groundwater or stormwater that originates upgradient from the site and flows across the site.

***The site will accept 6.26 acres of upgradient stormwater from the uncleared, undisturbed areas from the west. There is no impervious cover in this area and the stormwater will be allowed to flow across the site. All TBMPs are adequate for the drainage areas they serve.***

- b. A description of how BMPs and measures will prevent pollution of surface water or groundwater that originates on-site or flows off site, including pollution caused by contaminated stormwater runoff from the site.

***Site preparation, which is the initiation of all activity on the project, will disturb the largest amount of soil. Therefore, before any of this work can begin, the clearing and grading contractor will be responsible for the installation of all on-site control measures. The methodology for pollution prevention of on-site stormwater will include: (1) erection of silt fences along the downgradient boundary of construction activities for temporary erosion and sedimentation controls, (2) installation of rock berms with silt fencing downgradient from areas of concentrated stormwater flow for temporary erosion control, (3) Installation of gravel bags and drain inlet protection at inlets and downgradient areas of construction activities for sediment control (4) installation of stabilized construction entrance/exit(s) to reduce the dispersion of sediment from the site, and (5) installation of construction staging area(s).***

***Prior to the initiation of construction, all previously installed control measures will be repaired or reestablished for their designed or intended purpose. This work, which is the remainder of all activity on the project, may also disturb additional soil. The construction contractor will be responsible for the installation of all remaining on-site control measures that includes installation of the concrete truck washout pit(s), as construction phasing warrants.***

***Temporary measures are intended to provide a method of slowing the flow of runoff from the construction site in order to allow sediment and suspended solids to settle out of the runoff. By containing the sediment and solids within the site, they will not enter surface streams and/or sensitive features.***

- c. A description of how BMPs and measures will prevent pollutants from entering surface streams, sensitive features, or the aquifer.

***Temporary measures are intended to provide a method of slowing the flow of runoff from the construction site in order to allow sediment and suspended solids to settle out of the runoff. By containing the sediment and solids within the site, they will not enter surface streams and/or sensitive features.***

## TERALTA PHASE II

### Water Pollution Abatement Plan Modification

- d. A description of how, to the maximum extent practicable, BMPs and measures will maintain flow to naturally-occurring sensitive features identified in either the geologic assessment, TCEQ inspections, or during excavation, blasting, or construction.

*BMP measures utilized in this plan are intended to allow stormwater to continue downstream after passing through the BMPs. This will allow stormwater runoff to continue downgradient to streams or features that may exist downstream of the site.*

**ATTACHMENT F**

## TERALTA PHASE II

### Water Pollution Abatement Plan Modification

#### Attachment F – Structural Practices

The following structural measures will be installed prior to the initiation of site preparation activities:

- Erection of silt fences along the downgradient boundary of construction activities and rock berms with silt fence for secondary protection, as located on Exhibit 1 and illustrated in Exhibit 2.
- Installation of gravel bags and drain inlet protection at inlets and downgradient areas of construction activities, as located on Exhibit 1 and illustrated in Exhibit 2.
- Installation of stabilized construction entrance/exit(s) and construction staging area(s), as located on Exhibit 1, and illustrated on Exhibit 2.

The following structural measures will be installed at the initiation of construction activities or as appropriate based on the construction sequencing:

- Installation of concrete truck washout pit(s), as required and located on Exhibit 1 and illustrated on Exhibit 2.

**ATTACHMENT G**

**TERALTA PHASE II**  
**Water Pollution Abatement Plan**

**Attachment G – Drainage Area Map**

No more than ten (10) acres will be disturbed with these proposed improvements. All TBMPs utilized are adequate for the drainage areas served.

**ATTACHMENT I**

## **TERALTA PHASE II**

### **Water Pollution Abatement Plan Modification**

#### **INSPECTIONS**

Designated and qualified person(s) shall inspect Pollution Control Measures weekly and within 24 hours after a storm event. An inspection report that summarizes the scope of the inspection, names and qualifications of personnel conducting the inspection, date of the inspection, major observations, and actions taken as a result of the inspection shall be recorded and maintained as part of Storm Water TPDES data for a period of three years after the Notice of Termination (NOT) has been filed. A copy of the Inspection Report Form is provided in this Storm Water Pollution Prevention Plan.

As a minimum, the inspector shall observe: (1) significant disturbed areas for evidence of erosion, (2) storage areas for evidence of leakage from the exposed stored materials, (3) structural controls (rock berm outlets, silt fences, drainage swales, etc.) for evidence of failure or excess siltation (over 6 inches deep), (4) vehicle exit point for evidence of off-site sediment tracking, (5) vehicle storage areas for signs of leaking equipment or spills, (6) concrete truck rinse-out pit for signs of potential failure, (7) embankment, spillways, and outlet of sediment basin (where applicable) for erosion damage, and (8) sediment basins (where applicable) for evidence that basin has accumulated 50% of its volume in silt. Deficiencies noted during the inspection will be corrected and documented within seven calendar days following the inspection or before the next anticipated storm event if practicable.

Contractor shall review Sections 1.3 and 1.4 of TCEQ's Technical Guidance Manual for additional BMP inspection and maintenance requirements.

# TERALTA PHASE II

## Water Pollution Abatement Plan Modification

Pollution Prevention Measure	Inspected in Compliance	Corrective Action Required	
		Description (use additional sheet if necessary)	Date Completed
<b>Best Management Practices</b>			
Natural vegetation buffer strips			
Temporary vegetation			
Permanent vegetation			
Sediment control basin			
Silt fences			
Rock berms			
Gravel filter bags			
Drain inlet protection			
Other structural controls			
Vehicle exits (off-site tracking)			
Material storage areas (leakage)			
Equipment areas (leaks, spills)			
Concrete washout pit (leaks, failure)			
General site cleanliness			
Trash receptacles			
<b>Evidence of Erosion</b>			
Site preparation			
Roadway or parking lot construction			
Utility construction			
Drainage construction			
Building construction			
<b>Major Observations</b>			
Sediment discharges from site			
BMPs requiring maintenance			
BMPs requiring modification			
Additional BMPs required			

\_\_\_\_\_ A brief statement describing the qualifications of the inspector is included in this SWP3.

"I certify under penalty of law that this document and all attachments were prepared under my direction or supervision in accordance with a system designed to assure that qualified personnel properly gather and evaluate the information submitted. Based on my inquiry of the person or persons who manage the system, or those persons directly responsible for gathering the information, the information submitted is, to the best of my knowledge and belief, true, accurate, and complete. I am aware there are significant penalties for submitting false information, including the possibility of fine and imprisonment for knowing violations."

"I further certify I am an authorized signatory in accordance with the provisions of 30 TAC §305.128."

\_\_\_\_\_  
Inspector's Name

\_\_\_\_\_  
Inspector's Signature

\_\_\_\_\_  
Date

**TERALTA PHASE II  
Water Pollution Abatement Plan Modification**

**PROJECT MILESTONE DATES**

Date when major site grading activities begin:

<u>Construction Activity</u>	<u>Date</u>
Installation of BMPs	
_____	_____
_____	_____
_____	_____
_____	_____

Dates when construction activities temporarily or permanently cease on all or a portion of the project:

<u>Construction Activity</u>	<u>Date</u>
_____	_____
_____	_____
_____	_____
_____	_____

Dates when stabilization measures are initiated:

<u>Stabilization Activity</u>	<u>Date</u>
_____	_____
_____	_____
_____	_____
_____	_____
_____	_____
Removal of BMPs	
_____	_____

**ATTACHMENT J**

## TERALTA PHASE II

### Water Pollution Abatement Plan Modification

#### Attachment J - Schedule of Interim and Permanent Soil Stabilization Practices

Interim on-site stabilization measures, which are continuous, will include minimizing soil disturbances by exposing the smallest practical area of land required for the shortest period of time and maximizing use of natural vegetation. As soon as practical, all disturbed soil will be stabilized as per project specifications in accordance with pages 1-35 to 1-60 of TCEQ's Technical Guidance Manual (TGM) RG-348 (2005). Mulching, netting, erosion blankets and seeding are acceptable.

Stabilization measures will be initiated as soon as practicable in portions of the site where construction activities have temporarily or permanently ceased, and except as provided below, will be initiated no more than fourteen (14) days after the construction activity in that portion of the site has temporarily or permanently ceased. Where construction activity on a portion of the site is temporarily ceased, and earth disturbing activities will be resumed within twenty-one (21) days, temporary stabilization measures do not have to be initiated on that portion of site. In areas experiencing droughts where the initiation of stabilization measures by the 14<sup>th</sup> day after construction activity has temporarily or permanently ceased is precluded by seasonably arid conditions, stabilization measures must be initiated as soon as practicable.

**PERMANENT STORMWATER  
SECTION (TCEQ-0600)**

# Permanent Stormwater Section

## Texas Commission on Environmental Quality

for Regulated Activities on the Edwards Aquifer Recharge Zone and Relating to 30 TAC §213.5(b)(4)(C), (D)(ii), (E), and (5), Effective June 1, 1999

*To ensure that the application is administratively complete, confirm that all fields in the form are complete, verify that all requested information is provided, consistently reference the same site and contact person in all forms in the application, and ensure forms are signed by the appropriate party.*

*Note: Including all the information requested in the form and attachments contributes to more streamlined technical reviews.*

## Signature

To the best of my knowledge, the responses to this form accurately reflect all information requested concerning the proposed regulated activities and methods to protect the Edwards Aquifer. This **Permanent Stormwater Section** is hereby submitted for TCEQ review and executive director approval. The application was prepared by:

Print Name of Customer/Agent: Andrew Belton, P.E.

Date: 4/10/24

Signature of Customer/Agent



Regulated Entity Name: Teralta Phase II

## Permanent Best Management Practices (BMPs)

*Permanent best management practices and measures that will be used during and after construction is completed.*

- Permanent BMPs and measures must be implemented to control the discharge of pollution from regulated activities after the completion of construction.  
 N/A
- These practices and measures have been designed, and will be constructed, operated, and maintained to insure that 80% of the incremental increase in the annual mass loading of total suspended solids (TSS) from the site caused by the regulated activity is removed. These quantities have been calculated in accordance with technical guidance prepared or accepted by the executive director.  
 The TCEQ Technical Guidance Manual (TGM) was used to design permanent BMPs and measures for this site.

A technical guidance other than the TCEQ TGM was used to design permanent BMPs and measures for this site. The complete citation for the technical guidance that was used is: \_\_\_\_\_

N/A

3.  Owners must insure that permanent BMPs and measures are constructed and function as designed. A Texas Licensed Professional Engineer must certify in writing that the permanent BMPs or measures were constructed as designed. The certification letter must be submitted to the appropriate regional office within 30 days of site completion.

N/A

4. Where a site is used for low density single-family residential development and has 20 % or less impervious cover, other permanent BMPs are not required. This exemption from permanent BMPs must be recorded in the county deed records, with a notice that if the percent impervious cover increases above 20% or land use changes, the exemption for the whole site as described in the property boundaries required by 30 TAC §213.4(g) (relating to Application Processing and Approval), may no longer apply and the property owner must notify the appropriate regional office of these changes.

The site will be used for low density single-family residential development and has 20% or less impervious cover.

The site will be used for low density single-family residential development but has more than 20% impervious cover.

The site will not be used for low density single-family residential development.

5. The executive director may waive the requirement for other permanent BMPs for multi-family residential developments, schools, or small business sites where 20% or less impervious cover is used at the site. This exemption from permanent BMPs must be recorded in the county deed records, with a notice that if the percent impervious cover increases above 20% or land use changes, the exemption for the whole site as described in the property boundaries required by 30 TAC §213.4(g) (relating to Application Processing and Approval), may no longer apply and the property owner must notify the appropriate regional office of these changes.

**Attachment A - 20% or Less Impervious Cover Waiver.** The site will be used for multi-family residential developments, schools, or small business sites and has 20% or less impervious cover. A request to waive the requirements for other permanent BMPs and measures is attached.

The site will be used for multi-family residential developments, schools, or small business sites but has more than 20% impervious cover.

The site will not be used for multi-family residential developments, schools, or small business sites.

6.  **Attachment B - BMPs for Upgradient Stormwater.**

- A description of the BMPs and measures that will be used to prevent pollution of surface water, groundwater, or stormwater that originates upgradient from the site and flows across the site is attached.
  - No surface water, groundwater or stormwater originates upgradient from the site and flows across the site, and an explanation is attached.
  - Permanent BMPs or measures are not required to prevent pollution of surface water, groundwater, or stormwater that originates upgradient from the site and flows across the site, and an explanation is attached.
7.  **Attachment C - BMPs for On-site Stormwater.**
- A description of the BMPs and measures that will be used to prevent pollution of surface water or groundwater that originates on-site or flows off the site, including pollution caused by contaminated stormwater runoff from the site is attached.
  - Permanent BMPs or measures are not required to prevent pollution of surface water or groundwater that originates on-site or flows off the site, including pollution caused by contaminated stormwater runoff, and an explanation is attached.
8.  **Attachment D - BMPs for Surface Streams.** A description of the BMPs and measures that prevent pollutants from entering surface streams, sensitive features, or the aquifer is attached. Each feature identified in the Geologic Assessment as sensitive has been addressed.
- N/A
9.  The applicant understands that to the extent practicable, BMPs and measures must maintain flow to naturally occurring sensitive features identified in either the geologic assessment, executive director review, or during excavation, blasting, or construction.
- The permanent sealing of or diversion of flow from a naturally-occurring sensitive feature that accepts recharge to the Edwards Aquifer as a permanent pollution abatement measure has not been proposed.
  - Attachment E - Request to Seal Features.** A request to seal a naturally-occurring sensitive feature, that includes, for each feature, a justification as to why no reasonable and practicable alternative exists, is attached.
10.  **Attachment F - Construction Plans.** All construction plans and design calculations for the proposed permanent BMP(s) and measures have been prepared by or under the direct supervision of a Texas Licensed Professional Engineer, and are signed, sealed, and dated. The plans are attached and, if applicable include:
- Design calculations (TSS removal calculations)
  - TCEQ construction notes
  - All geologic features
  - All proposed structural BMP(s) plans and specifications
- N/A

11.  **Attachment G - Inspection, Maintenance, Repair and Retrofit Plan.** A plan for the inspection, maintenance, repairs, and, if necessary, retrofit of the permanent BMPs and measures is attached. The plan includes all of the following:
- Prepared and certified by the engineer designing the permanent BMPs and measures
  - Signed by the owner or responsible party
  - Procedures for documenting inspections, maintenance, repairs, and, if necessary retrofit
  - A discussion of record keeping procedures
- N/A
12.  **Attachment H - Pilot-Scale Field Testing Plan.** Pilot studies for BMPs that are not recognized by the Executive Director require prior approval from the TCEQ. A plan for pilot-scale field testing is attached.
- N/A
13.  **Attachment I -Measures for Minimizing Surface Stream Contamination.** A description of the measures that will be used to avoid or minimize surface stream contamination and changes in the way in which water enters a stream as a result of the construction and development is attached. The measures address increased stream flashing, the creation of stronger flows and in-stream velocities, and other in-stream effects caused by the regulated activity, which increase erosion that results in water quality degradation.
- N/A

### ***Responsibility for Maintenance of Permanent BMP(s)***

***Responsibility for maintenance of best management practices and measures after construction is complete.***

14.  The applicant is responsible for maintaining the permanent BMPs after construction until such time as the maintenance obligation is either assumed in writing by another entity having ownership or control of the property (such as without limitation, an owner's association, a new property owner or lessee, a district, or municipality) or the ownership of the property is transferred to the entity. Such entity shall then be responsible for maintenance until another entity assumes such obligations in writing or ownership is transferred.
- N/A
15.  A copy of the transfer of responsibility must be filed with the executive director at the appropriate regional office within 30 days of the transfer if the site is for use as a multiple single-family residential development, a multi-family residential development, or a non-residential development such as commercial, industrial, institutional, schools, and other sites where regulated activities occur.
- N/A

**ATTACHMENT B**

## TERALTA PHASE II

### Water Pollution Abatement Plan Modification

#### Attachment B – BMPs for Upgradient Stormwater

The site will accept 6.26 acres of upgradient stormwater from the uncleared, undisturbed area from the west and be routed through the existing sedimentation basin, which has been adequately sized.

The proposed Permanent Best Management Practices (PBMPs) for stormwater treatment for the overall 12.72- acre site are one (1) existing, approved sedimentation basin (ID 13000111) and one (1) existing, approved fifteen-foot (15') engineered vegetative filter strip (ID 13000111), which were designed in accordance with the TCEQ's Technical Guidance Manual (TGM) RG-348 (2005) to remove 80% of the increase in Total Suspended Solids (TSS) from the site.

**ATTACHMENT C**

## TERALTA PHASE II

### Water Pollution Abatement Plan Modification

#### Attachment C – BMPs for On-Site Stormwater

The proposed Permanent Best Management Practices (PBMPs) for stormwater treatment for the overall 12.72- acre site are one (1) existing, approved sedimentation basin (ID 13000111) and one (1) existing, approved fifteen-foot (15') engineered vegetative filter strip (ID 13000111), which were designed in accordance with the TCEQ's Technical Guidance Manual (TGM) RG-348 (2005) to remove 80% of the increase in Total Suspended Solids (TSS) from the site.

**ATTACHMENT D**

## TERALTA PHASE II

### Water Pollution Abatement Plan Modification

#### Attachment D – BMPs for Surface Streams

There are no surface streams on or adjacent to the project limits.

The proposed Permanent Best Management Practices (PBMPs) for stormwater treatment for the overall 12.72- acre site are one (1) existing, approved sedimentation basin (ID 13000111) and one (1) existing, approved fifteen-foot (15') engineered vegetative filter strip (ID 13000111), which were designed in accordance with the TCEQ's Technical Guidance Manual (TGM) RG-348 (2005) to remove 80% of the increase in Total Suspended Solids (TSS) from the site.

**ATTACHMENT F**

**TERALTA PHASE II**  
**Water Pollution Abatement Plan Modification**

**Attachment F – Construction Plans**

Please refer to the Exhibits Section of this application for the Water Pollution Abatement Site Plans.

**ATTACHMENT G**

**TERALTA PHASE II**  
**Water Pollution Abatement Plan**

**PERMANENT POLLUTION ABATEMENT MEASURES**  
**MAINTENANCE SCHEDULE AND MAINTENANCE PROCEDURES**

This document has been prepared to provide a description and schedule for the performance of maintenance on permanent pollution abatement measures. Maintenance measures to be performed will be dependent on what permanent pollution abatement measures are incorporated into the project. The project specific water pollution abatement plan should be reviewed to determine what permanent pollution abatement measures are incorporated in to a project.

It should also be noted that the timing and procedures presented herein are general guidelines, adjustment to the timing and procedures may have to be made depending on project specific characteristics as well as weather related conditions but may not be altered without TCEQ approval.

Where a project is occupied by the owner, the owner may provide for maintenance with his own skilled forces or contract for recommended maintenance of Permanent Best Management Practices. Where a project is occupied or leased by a tenant, the owner shall require tenants to contract for such maintenance services either through a lease agreement, property owners association covenants, or other binding document.

I understand that I am responsible for maintenance of the Permanent Pollution Abatement Measures included in this project until such time as the maintenance obligation is either assumed in writing by another entity having ownership or control of the property or ownership is transferred.

I, the owner, have read and understand the requirements of the attached Maintenance Plan and Schedule.



William T. Ellis, Manager  
Teralta Partners, Ltd.



Date

# TERALTA PHASE II

## Water Pollution Abatement Plan

### INSPECTION AND MAINTENANCE SCHEDULE FOR PERMANENT POLLUTION ABATEMENT MEASURES

Recommended Frequency	Task to be Performed													
	1	2	3	4	5	6	7	8	9	10	11	12	13	14
After Rainfall	√							√	√	√	√		√	
Biannually*	√	√	√	√	√	√	√	√	√	√	√	√	√	√

**\*At least one biannual inspection must occur during or immediately after a rainfall event.  
√Indicates maintenance procedure that applies to this specific site.**

See description of maintenance task to be performed on the following pages. Frequency of maintenance tasks may vary depending on amount of rainfall and other weather related conditions but may not be altered without TCEQ approval.

*A written record should be kept of inspection results and maintenance performed.*

<b>Task No. &amp; Description</b>	<b>Included in this project</b>	
1. Check Depth of Vegetation	Yes	No
2. Check Depth of Silt Deposit in Basin	Yes	No
3. Removal of Debris and Trash	Yes	No
4. Cut-off Valve	Yes	No
5. Inlet Splash Pad	Yes	No
6. Underdrain System	Yes	No
7. Structural Integrity	Yes	No
8. Discharge Pipe	Yes	No
9. Drawdown Time	Yes	No
10. Vegetated Filter Strips	Yes	No
11. For Pump Stations	Yes	No
12. For Pump Stations	Yes	No
13. For Pump Stations	Yes	No
14. Visually Inspect Security Fencing for Damage or Breach	Yes	No

## TERALTA PHASE II

### Water Pollution Abatement Plan

#### MAINTENANCE PROCEDURES FOR PERMANENT POLLUTION ABATEMENT MEASURES

**Note: Additional guidance can be obtained from TCEQ's Technical Guidance Manual (TGM) RG-348 (2005) Section 3.5.**

1. Check Depth of Vegetation. Vegetation in the basin shall not exceed 18-inches in depth. When vegetation needs to be cut, it shall be cut to an approximately 4-inch height. *A written record should be kept of inspection results and maintenance performed.*
2. Check Depth of Silt Deposit in Basin. Top of cleanouts shall be set 4-inches above sand layer. When silt has accumulated to top of cleanouts, the silt shall be removed. The top two (2) inches of the sand media shall also be removed and replaced with clean, silica-based washed sand meeting ASTM C33 specifications [0.0165 inch (#40 sieve) to 0.0469 inch (#16 sieve)]. Silt/sediment shall be cleared from the inlet structure at least every year and from the basin at least every five (5) years. Any sand discolored as a result of apparent impact by petroleum hydrocarbon or hazardous materials should also be removed and replaced. *Written record should be kept of inspection results and maintenance performed.*
3. Removal of Debris and Trash. The basin and inlet structure shall be checked for the accumulation of debris and trash such as brush, limbs, leaves, paper cups, aluminum cans, plastic bottles etc. Accumulated trash and debris shall be raked or collected from the basin and inlet structure and disposed of properly. *Written record should be kept of inspection results and maintenance performed.*
4. Cut-off Valve. The cut-off valve shall be turned to confirm full opening and full closure. Prior to operating the valve, the valve setting shall be checked to determine the position to which the valve is to be returned (which should limit drawdown time of the basin between 24-hours and 48-hours). Count should be kept of number of turns to open and close the valve so that the valve can be reset to the starting position. Defects in the operation of the cut-off valve shall be corrected within 7 working days. *A written record should be kept of inspection results and maintenance performed.*
5. Inlet Splash Pad. The filter area around the inlet splash pad shall be checked for erosion and for the condition of the rock rubble. Erosion or disturbance of the rock rubble should be corrected by removing the rock rubble, restoring missing sand media to appropriate depth and replacement of the rock rubble. If the condition persists in subsequent inspections, the size of the rock rubble should be increased. Rubble should be placed to a density that minimizes the amount of exposed sand between the rock rubble. Deficiencies should be corrected within seven working days. *A written record should be kept of inspection results and maintenance performed.*
6. Underdrain System. The underdrain system shall be visually inspected for the accumulation of silt in the pipe system. The pipe clean-outs shall have the caps removed and visually inspected for accumulation of silt deposits. If silt deposits appear to have accumulated so as to significantly reduce the drain capacity of the pipes, then maintenance shall be performed. When silt deposits have accumulated to the stage described above, the clean-outs and drainpipes can be flushed with a high-pressure water flushing process. Clean-out caps must be replaced onto the clean-outs after

## TERALTA PHASE II

### Water Pollution Abatement Plan

maintenance so as to avoid the possibility of short circuiting the filtering process. Sediment accumulation at outlet pipe or in wet well due to flushing shall be removed and disposed of properly. *A written record should be kept of inspection results and the maintenance performed.*

7. Structural Integrity. In addition to Items 1 through 6 the following are measures which should be reviewed during a check of structural integrity:
  - Observe the height of the confining berm for visible signs of erosion or potential breach. Signs of erosion should be identified and repaired immediately. Corrective measures include but are not limited to addition of topsoil or appropriate soil material so as to restore the original berm height of the sand filter basin. Restored areas shall be protected through placement of solid block sod.
  - Bypass of filter process. This condition can manifest itself in several ways. One way is by visually inspecting the clean-outs for accumulation of silt as described in Item 6. Significant accumulations of silt could be a sign of a torn filter fabric. Observations should be made over several inspection cycles to determine whether the condition persists. A second non-intrusive way of making observations for structural condition would be to visually look for collapsed or depressed areas along the edge of the filter media interface with basin side slope. If condition exists, corrective action should be performed within 15 working days. Removal of sand and replacement of filter fabric and/or pipe and gravel may be necessary. *A written record should be kept of inspection results and corrective measures taken.*
8. Discharge Pipe. The basin discharge pipe shall be checked for accumulation of silt, debris or other obstructions which could block flow. Soil accumulations, vegetative overgrowth and other blockages should be cleared from the pipe discharge point. Erosion at the point of discharge shall be monitored. If erosion occurs, the addition of rock rubble to disperse the flow should be accomplished. *A written record should be kept of inspection results and corrective measures taken*
9. Drawdown Time. This characteristic can be a sign of the need for maintenance. The minimum drawdown time is 24 hours. If drawdown time is less than 24 hours, the gate valve shall be checked and partially closed to limit the drawdown time. Extensive drawdown time greater than 48 hours may indicated blockage of the sand media, the underdrain system and/or the discharge pipe. Corrective actions should be performed and completed within 15 working days. *A written record of the inspection findings and corrective actions performed should be made.*
10. Vegetated Filter Strips. Vegetation height for native grasses shall be limited to no more than 18-inches. When vegetation exceeds that height, the filter strip shall be cut to a height of approximately 4 inches. Turf grass shall be limited to a height of 4-inches with regular maintenance that utilizes a mulching mower. Trash and debris shall be removed from filter strip prior to cutting. Check filter strip for signs of concentrated flow and erosion. Areas of filter strip showing signs of erosion shall be repaired by scarifying the eroded area, reshaping, regrading and placement of solid block sod over the affected area. *A written record of the inspection findings and corrective actions performed should be made*
11. For Pump Stations. Check wet well discharge pipe to confirm flow through the pump system. If flow is not present, allow sufficient time for pump to cycle on and off. If flow does not occur, the wet

## TERALTA PHASE II

### Water Pollution Abatement Plan

well should be checked for the level of water. The wet well should be opened and the on/off float switches should be moved up and down to activate the pump. If the pump does not start, a repair technician shall be called in to repair the malfunction within 5 working days. *A written record of the inspection findings and corrective actions performed should be made*

12. For Pump Stations. Check the wet well for accumulation for trash, debris and silt. Trash and debris shall be removed and disposed of properly. Silt depth can be checked by probing the bottom of the wet well with a stick or PVC pipe. Silt accumulations should be removed when silt collects to a depth of three (3) inches over the entire wet well bottom. Silt can be removed by vacuum pump method. If silt buildup continues, underdrain system shall be inspected. *A written record should be kept of inspection results and maintenance performed.*
13. For Pump Stations. Visually check aboveground pump wiring and connections for damage. Damaged or loose connections should be repaired within 5 working days. *A written record should be kept of inspection results and the maintenance performed.*
14. Visually Inspect Security Fencing for Damage or Breach. Check maintenance access gates for proper operation. Damage to fencing or gates shall be repaired within 5 working days. *A written record should be kept of inspection results and maintenance performed.*

**ATTACHMENT I**

## TERALTA PHASE II Water Pollution Abatement Plan Modification

### Attachment I – Measures for Minimizing Surface Stream Contamination

Any points where discharge from the site is concentrated and erosive velocities exist will include appropriately sized energy dissipators to reduce velocities to non-erosive levels.

**AGENT AUTHORIZATION FORM  
(TCEQ-0599)**

**Agent Authorization Form**  
For Required Signature  
Edwards Aquifer Protection Program  
Relating to 30 TAC Chapter 213  
Effective June 1, 1999

I William T. Ellis,  
Print Name

Manager,  
Title - Owner/President/Other

of Teralta Partners, Ltd.,  
Corporation/Partnership/Entity Name

have authorized **Pape-Dawson Consulting Engineers, LLC**  
Print Name of Agent/Engineer

of **Pape-Dawson Consulting Engineers, LLC**  
Print Name of Firm

to represent and act on the behalf of the above named Corporation, Partnership, or Entity for the purpose of preparing and submitting this plan application to the Texas Commission on Environmental Quality (TCEQ) for the review and approval consideration of regulated activities.

I also understand that:

1. The applicant is responsible for compliance with 30 Texas Administrative Code Chapter 213 and any condition of the TCEQ's approval letter. The TCEQ is authorized to assess administrative penalties of up to \$10,000 per day per violation.
2. For those submitting an application who are not the property owner, but who have the right to control and possess the property, additional authorization is required from the owner.
3. Application fees are due and payable at the time the application is submitted. The application fee must be sent to the TCEQ cashier or to the appropriate regional office. The application will not be considered until the correct fee is received by the commission.
4. A notarized copy of the Agent Authorization Form must be provided for the person preparing the application, and this form must accompany the completed application.
5. No person shall commence any regulated activity on the Edwards Aquifer Recharge Zone, Contributing Zone or Transition Zone until the appropriate application for the activity has been filed with and approved by the Executive Director.

SIGNATURE PAGE:

*Bill Ellis*  
Applicant's Signature

3/22/2024  
Date

THE STATE OF Texas §  
County of Bexar §

BEFORE ME, the undersigned authority, on this day personally appeared William Z. Ellis known to me to be the person whose name is subscribed to the foregoing instrument, and acknowledged to me that (s)he executed same for the purpose and consideration therein expressed.

GIVEN under my hand and seal of office on this 22nd day of March, 2024.

*Lori A. Davis*  
NOTARY PUBLIC

Lori A. Davis  
Typed or Printed Name of Notary

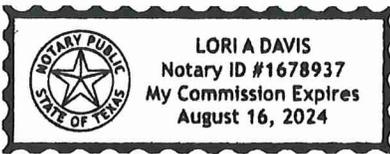

MY COMMISSION EXPIRES: August 16, 2024

**APPLICATION FEE FORM  
(TCEQ-0574)**

# Application Fee Form

## Texas Commission on Environmental Quality

Name of Proposed Regulated Entity: Teralta Phase II

Regulated Entity Location: 4949 N Loop 1604 W, San Antonio, TX 78249

Name of Customer: Teralta Partners, Ltd

Contact Person: William T. Ellis

Phone: (210) 402-0800

Customer Reference Number (if issued): CN 605101831

Regulated Entity Reference Number (if issued): RN 109119271

### Austin Regional Office (3373)

Hays

Travis

Williamson

### San Antonio Regional Office (3362)

Bexar

Medina

Uvalde

Comal

Kinney

Application fees must be paid by check, certified check, or money order, payable to the **Texas Commission on Environmental Quality**. Your canceled check will serve as your receipt. **This form must be submitted with your fee payment.** This payment is being submitted to:

Austin Regional Office

San Antonio Regional Office

Mailed to: TCEQ - Cashier

Overnight Delivery to: TCEQ - Cashier

Revenues Section

12100 Park 35 Circle

Mail Code 214

Building A, 3rd Floor

P.O. Box 13088

Austin, TX 78753

Austin, TX 78711-3088

(512)239-0357

### Site Location (Check All That Apply):

Recharge Zone

Contributing Zone

Transition Zone

Type of Plan	Size	Fee Due
Water Pollution Abatement Plan, Contributing Zone Plan: One Single Family Residential Dwelling	Acres	\$
Water Pollution Abatement Plan, Contributing Zone Plan: Multiple Single Family Residential and Parks	Acres	\$
Water Pollution Abatement Plan, Contributing Zone Plan: Non-residential	12.72 Acres	\$ 6,500
Sewage Collection System	157 L.F.	\$ 650
Lift Stations without sewer lines	Acres	\$
Underground or Aboveground Storage Tank Facility	Tanks	\$
Piping System(s)(only)	Each	\$
Exception	Each	\$
Extension of Time	Each	\$

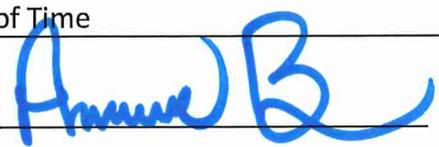
Signature: 

Date: 4/10/24

# Application Fee Schedule

Texas Commission on Environmental Quality

Edwards Aquifer Protection Program 30 TAC Chapter 213 (effective 05/01/2008)

## **Water Pollution Abatement Plans and Modifications**

### **Contributing Zone Plans and Modifications**

<i>Project</i>	<i>Project Area in Acres</i>	<i>Fee</i>
One Single Family Residential Dwelling	< 5	\$650
Multiple Single Family Residential and Parks	< 5	\$1,500
	5 < 10	\$3,000
	10 < 40	\$4,000
	40 < 100	\$6,500
	100 < 500	\$8,000
	≥ 500	\$10,000
Non-residential (Commercial, industrial, institutional, multi-family residential, schools, and other sites where regulated activities will occur)	< 1	\$3,000
	1 < 5	\$4,000
	5 < 10	\$5,000
	10 < 40	\$6,500
	40 < 100	\$8,000
	≥ 100	\$10,000

### **Organized Sewage Collection Systems and Modifications**

<i>Project</i>	<i>Cost per Linear Foot</i>	<i>Minimum Fee- Maximum Fee</i>
Sewage Collection Systems	\$0.50	\$650 - \$6,500

### **Underground and Aboveground Storage Tank System Facility Plans and Modifications**

<i>Project</i>	<i>Cost per Tank or Piping System</i>	<i>Minimum Fee- Maximum Fee</i>
Underground and Aboveground Storage Tank Facility	\$650	\$650 - \$6,500

### **Exception Requests**

<i>Project</i>	<i>Fee</i>
Exception Request	\$500

### **Extension of Time Requests**

<i>Project</i>	<i>Fee</i>
Extension of Time Request	\$150

**CORE DATA FORM  
(TCEQ-10400)**



TCEQ Use Only

# TCEQ Core Data Form

For detailed instructions regarding completion of this form, please read the Core Data Form Instructions or call 512-239-5175.

## SECTION I: General Information

<b>1. Reason for Submission</b> (If other is checked please describe in space provided.)		
<input checked="" type="checkbox"/> New Permit, Registration or Authorization (Core Data Form should be submitted with the program application.)		
<input type="checkbox"/> Renewal (Core Data Form should be submitted with the renewal form)	<input type="checkbox"/> Other	
<b>2. Customer Reference Number</b> (if issued)	<a href="#">Follow this link to search for CN or RN numbers in Central Registry**</a>	<b>3. Regulated Entity Reference Number</b> (if issued)
CN 605010183		RN 109119271

## SECTION II: Customer Information

<b>4. General Customer Information</b>		<b>5. Effective Date for Customer Information Updates</b> (mm/dd/yyyy)	
<input type="checkbox"/> New Customer		<input type="checkbox"/> Update to Customer Information	
<input type="checkbox"/> Change in Legal Name (Verifiable with the Texas Secretary of State or Texas Comptroller of Public Accounts)		<input type="checkbox"/> Change in Regulated Entity Ownership	
<b>The Customer Name submitted here may be updated automatically based on what is current and active with the Texas Secretary of State (SOS) or Texas Comptroller of Public Accounts (CPA).</b>			
<b>6. Customer Legal Name</b> (If an individual, print last name first: eg: Doe, John)		If new Customer, enter previous Customer below:	
Teralta Partners, Ltd			
<b>7. TX SOS/CPA Filing Number</b>	<b>8. TX State Tax ID</b> (11 digits)	<b>9. Federal Tax ID</b> (9 digits)	<b>10. DUNS Number</b> (if applicable)
<b>11. Type of Customer:</b>	<input type="checkbox"/> Corporation	<input type="checkbox"/> Individual	Partnership: <input type="checkbox"/> General <input type="checkbox"/> Limited
Government: <input type="checkbox"/> City <input type="checkbox"/> County <input type="checkbox"/> Federal <input type="checkbox"/> State <input type="checkbox"/> Other	<input type="checkbox"/> Sole Proprietorship	<input type="checkbox"/> Other:	
<b>12. Number of Employees</b>		<b>13. Independently Owned and Operated?</b>	
<input type="checkbox"/> 0-20 <input type="checkbox"/> 21-100 <input type="checkbox"/> 101-250 <input type="checkbox"/> 251-500 <input type="checkbox"/> 501 and higher		<input type="checkbox"/> Yes <input type="checkbox"/> No	
<b>14. Customer Role</b> (Proposed or Actual) – as it relates to the Regulated Entity listed on this form. Please check one of the following			
<input type="checkbox"/> Owner		<input type="checkbox"/> Operator	
<input type="checkbox"/> Occupational Licensee		<input type="checkbox"/> Responsible Party	
<input type="checkbox"/> Owner & Operator		<input type="checkbox"/> Voluntary Cleanup Applicant	
<input type="checkbox"/> Other:			
<b>15. Mailing Address:</b>			
	City	State	ZIP
<b>16. Country Mailing Information</b> (if outside USA)		<b>17. E-Mail Address</b> (if applicable)	
<b>18. Telephone Number</b>	<b>19. Extension or Code</b>	<b>20. Fax Number</b> (if applicable)	
( ) -		( ) -	

## SECTION III: Regulated Entity Information

<b>21. General Regulated Entity Information</b> (If 'New Regulated Entity' is selected below this form should be accompanied by a permit application)
<input type="checkbox"/> New Regulated Entity <input checked="" type="checkbox"/> Update to Regulated Entity Name <input checked="" type="checkbox"/> Update to Regulated Entity Information
<b>The Regulated Entity Name submitted may be updated in order to meet TCEQ Agency Data Standards (removal of organizational endings such as Inc, LP, or LLC).</b>
<b>22. Regulated Entity Name</b> (Enter name of the site where the regulated action is taking place.)
Teralta Phase II

23. Street Address of the Regulated Entity: <i>(No PO Boxes)</i>	4949 N Loop 1604 W						
	City	SanAntonio	State	TX	ZIP	78249	ZIP + 4
24. County							

Enter Physical Location Description if no street address is provided.

25. Description to Physical Location:							
26. Nearest City	State				Nearest ZIP Code		
27. Latitude (N) In Decimal:	29.593056 N		28. Longitude (W) In Decimal:	-98.582778 W			
Degrees	Minutes	Seconds	Degrees	Minutes	Seconds		
29	35	35.0	-98	34	58.8		
29. Primary SIC Code (4 digits)	30. Secondary SIC Code (4 digits)	31. Primary NAICS Code (5 or 6 digits)		32. Secondary NAICS Code (5 or 6 digits)			
1542	1623	236220		237110			
33. What is the Primary Business of this entity? <i>(Do not repeat the SIC or NAICS description.)</i>							
Corportate office							
34. Mailing Address:	70 NE Loop 410, Ste 250						
	City	San Antonio	State	TX	ZIP	78216	ZIP + 4
35. E-Mail Address:	bellis@sirell.com						
36. Telephone Number	37. Extension or Code		38. Fax Number <i>(if applicable)</i>				
( 210 ) 402-800			( 210 ) 402-805				

39. TCEQ Programs and ID Numbers Check all Programs and write in the permits/registration numbers that will be affected by the updates submitted on this form. See the Core Data Form instructions for additional guidance.

<input type="checkbox"/> Dam Safety	<input type="checkbox"/> Districts	<input checked="" type="checkbox"/> Edwards Aquifer	<input type="checkbox"/> Emissions Inventory Air	<input type="checkbox"/> Industrial Hazardous Waste
<input type="checkbox"/> Municipal Solid Waste	<input type="checkbox"/> New Source Review Air	<input type="checkbox"/> OSSF	<input type="checkbox"/> Petroleum Storage Tank	<input type="checkbox"/> PWS
<input type="checkbox"/> Sludge	<input type="checkbox"/> Storm Water	<input type="checkbox"/> Title V Air	<input type="checkbox"/> Tires	<input type="checkbox"/> Used Oil
<input type="checkbox"/> Voluntary Cleanup	<input type="checkbox"/> Waste Water	<input type="checkbox"/> Wastewater Agriculture	<input type="checkbox"/> Water Rights	<input type="checkbox"/> Other:

**SECTION IV: Preparer Information**

40. Name:	Jean Autrey, P.E., CESSWI	41. Title:	Project Manager
42. Telephone Number	43. Ext./Code	44. Fax Number	45. E-Mail Address
( 210 ) 375-9000		( 210 ) 375-9010	jautrey@pape-dawson.com

**SECTION V: Authorized Signature**

46. By my signature below, I certify, to the best of my knowledge, that the information provided in this form is true and complete, and that I have signature authority to submit this form on behalf of the entity specified in Section II, Field 6 and/or as required for the updates to the ID numbers identified in field 39.

Company:	Pape-Dawson Consulting Engineers, LLC	Job Title:	Vice President
Name <i>(In Print)</i> :	Andrew Belton, P.E.	Phone:	( 210 ) 375- 9000
Signature:		Date:	7/10/24

# **POLLUTANT LOAD AND REMOVAL CALCULATIONS**

**TERALTA PHASE II**

**Treatment Summary by Watershed**

Watershed	Total Watershed Area (ac.)	Existing Impervious Cover (ac.)	Proposed Impervious Cover (ac.)	PBMP	Required TSS Removal Annually (lbs)	TSS Removed Annually (lbs)
A	11.11	0.83	8.01	Existing Water Quality Basin "A" (EAPP ID No 13000111)	5,859	5,940
OFFSITE	6.26	0.00	0.00	Existing Water Quality Basin "A" (EAPP ID No 13000111)	0	0
UNCAPTURED AREA B	0.12	0.00	0.10	Overtreatment Water Quality Basin "A"	82	N/A
C	0.68	0.00	0.47	Existing 15' Engineered VFS (EAPP ID No. 13000111)	384	384
<b>TOTAL</b>	<b>18.17</b>	<b>0.83</b>	<b>8.58</b>	---	<b>6,324</b>	<b>6,324</b>
TOTAL ONSITE:	<b>11.91</b>					

**Water Quality Basin Summary**

Basin	Designed Capture Volume (cf)	Required Volume (cf)	Excess Volume Capacity (cf)	Designed Sand Area (sf)	Required Sand Area (sf)	Excess Sand Area (sf)
A	34,301	28,188	6,113	3,469	2,819	650

approved designed TSS is 6520 lbs

Additional information is provided for cells with a red triangle in the upper right corner. Place the cursor over the cell.  
Text shown in blue indicate location of instructions in the Technical Guidance Manual - RG-348.  
Characters shown in red are data entry fields.  
Characters shown in black (Bold) are calculated fields. Changes to these fields will remove the equations used in the spreadsheet.

**1. The Required Load Reduction for the total project:** Calculations from RG-348 Pages 3-27 to 3-30

Page 3-29 Equation 3.3:  $L_{t, \text{TOTAL PROJECT}} = 27.2(A_{i,p} \times P)$

where:  $L_{t, \text{TOTAL PROJECT}}$  = Required TSS removal resulting from the proposed development = 80% of Increased load  
 $A_{i,p}$  = Net Increase in Impervious area for the project  
 $P$  = Average annual precipitation, inches

Site Data: Determine Required Load Removal Based on the Entire Project  
County = **Bexar**  
Total project area included in plan = **12.72** acres  
Predevelopment impervious area within the limits of the plan = **0.83** acres  
Total post-development impervious area within the limits of the plan = **8.58** acres  
Total post-development impervious cover fraction = **0.67**  
 $P$  = **39** inches

$L_{t, \text{TOTAL PROJECT}}$  = **6324** lbs.

\* The values entered in these fields should be for the total project area.

Number of drainage basins / outfalls areas leaving the plan area = **1**

**2. Drainage Basin Parameters (This information should be provided for each basin):**

Drainage Basin/Outfall Area No. = **A**  
Total drainage basin/outfall area = **11.11** acres  
Predevelopment impervious area within drainage basin/outfall area = **0.83** acres  
Post-development impervious area within drainage basin/outfall area = **8.51** acres  
Post-development impervious fraction within drainage basin/outfall area = **0.72**  
 $L_{t, \text{THIS BASIN}}$  = **5859** lbs.

**3. Indicate the proposed BMP Code for this basin.**

Proposed BMP = **Sand Filter**  
Removal efficiency = **89** percent

- Aquatic Cartridge Filter
- Bio-retention
- Contech Storm Filter
- Constructed Wetland
- Extended Detention
- Grassy Swale
- Retention / Infiltration
- Sand Filter
- Stormceptor
- Vegetated Filter Strips
- Vortex
- Wet Basin
- Wet Vault

**4. Calculate Maximum TSS Load Removed  $L_{t,r}$  for this Drainage Basin by the selected BMP Type.**

RG-348 Page 3-33 Equation 3.7:  $L_{t,r} = (\text{BMP efficiency}) \times P \times (A_i \times 34.8 + A_p \times 0.54)$

where:  $A_i$  = Total On-Site drainage area in the BMP catchment area  
 $A_p$  = Impervious area proposed in the BMP catchment area  
 $A_r$  = Pervious area remaining in the BMP catchment area  
 $L_{t,r}$  = TSS Load removed from this catchment area by the proposed BMP

$A_i$  = **11.11** acres  
 $A_p$  = **8.01** acres  
 $A_r$  = **3.10** acres  
 $L_{t,r}$  = **7444** lbs

**5. Calculate Fraction of Annual Runoff to Treat the drainage basin / outfall area.**

Desired  $L_{t, \text{THIS BASIN}}$  = **5940** lbs.  
 $F$  = **0.80**

**6. Calculate Capture Volume required by the BMP Type for this drainage basin / outfall area.** Calculations from RG-348 Pages 3-34 to 3-36

Rainfall Depth = **1.08** inches  
Post Development Runoff Coefficient = **0.83**  
On-site Water Quality Volume = **23970** cubic feet

Calculations from RG-348 Pages 3-36 to 3-37

Off-site area draining to BMP = **8.28** acres  
Off-site impervious cover draining to BMP = **0.80** acres  
Impervious fraction of off-site area = **0.00**  
Off-site Runoff Coefficient = **0.02**  
Off-site Water Quality Volume = **491** cubic feet

Storage for Sediment = **4692**  
Total Capture Volume (required water quality volume(s) x 1.20) = **28153** cubic feet

The following sections are used to calculate the required water quality volume(s) for the selected BMP.  
The values for BMP Types not selected in cell C45 will show NA.

**7. Retention/Irrigation System** Designed as Required in RG-348 Pages 3-42 to 3-46

Required Water Quality Volume for retention basin = **NA** cubic feet

Irrigation Area Calculations:

Soil Infiltration/permeability rate = **0.1** in/hr Enter determined permeability rate or assumed value of  
Irrigation area = **NA** square feet  
**NA** acres

**8. Extended Detention Basin System** Designed as Required in RG-348 Pages 3-46 to 3-51

Required Water Quality Volume for extended detention basin = **NA** cubic feet

**9. Filter area for Sand Filters** Designed as Required in RG-348 Pages 3-58 to 3-63

**9A. Full Sedimentation and Filtration System**

Water Quality Volume for sedimentation basin = **28153** cubic feet  
Minimum filter basin area = **1276** square feet  
Maximum sedimentation basin area = **11485** square feet For minimum water depth of 2 feet  
Minimum sedimentation basin area = **2871** square feet For maximum water depth of 8 feet

**9B. Partial Sedimentation and Filtration System**

Water Quality Volume for combined basins = **28153** cubic feet  
Minimum filter basin area = **2287** square feet  
Maximum sedimentation basin area = **9188** square feet For minimum water depth of 2 feet  
Minimum sedimentation basin area = **574** square feet For maximum water depth of 8 feet

*Andrew B*



*4/10/24*

# **EXHIBITS**

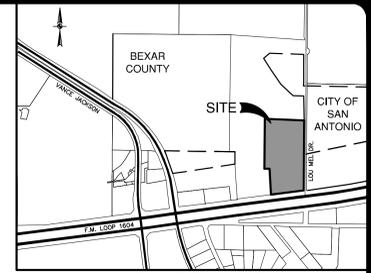

**LOCATION MAP**  
NOT TO SCALE  
LEGAL DESCRIPTION: LOT 4, BLOCK 1, CB 4776 (PLAT # 160338)  
ADDRESS: 4949 N LOOP 1604 W, SAN ANTONIO, TEXAS 78249

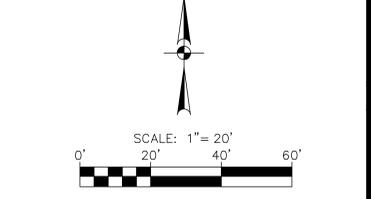

**LEGEND**

	EXISTING WATER LINE
	PROPOSED UNDERGROUND ELECTRIC
	EXISTING SANITARY SEWER
	PROPOSED SANITARY SEWER
	EXISTING STORM DRAINAGE
	EXISTING CONTOURS
	PROPOSED CONTOURS
	100' SEWER ENVELOPE

**NOTE**  
SEE C6.30 FOR TCEQ AND SAWS CONSTRUCTION NOTES

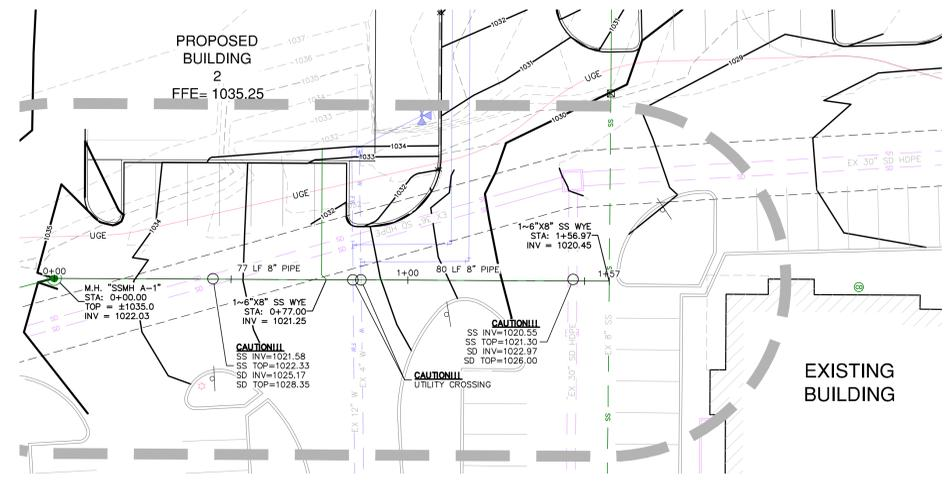

SS LINE A  
(STA. 0+00.00 TO END)

HORIZONTAL SCALE 1" = 20' H  
VERTICAL SCALE: 1" = 5' V

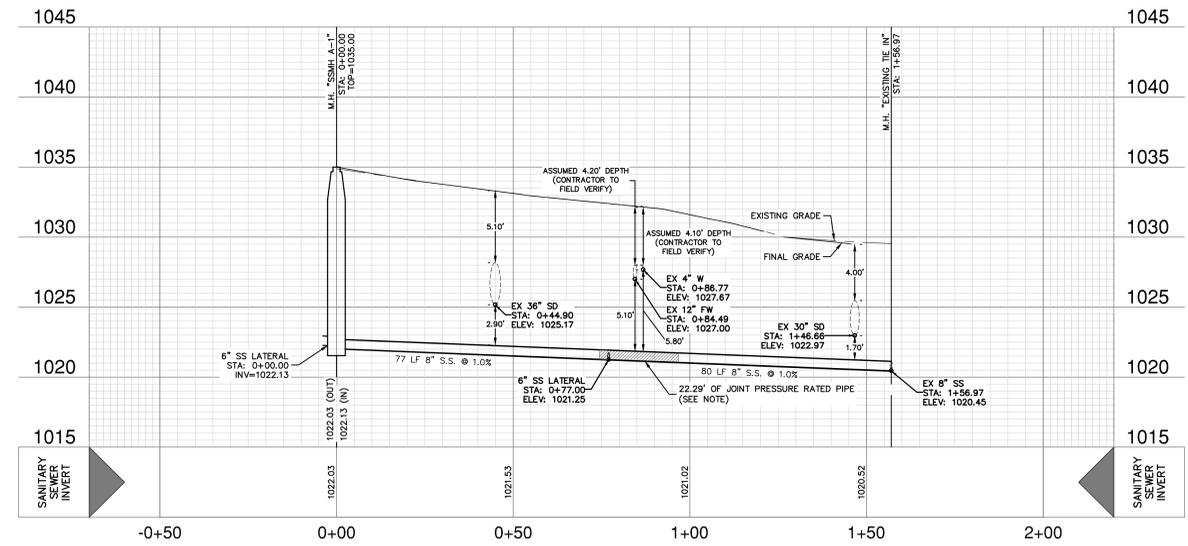

**TRENCH EXCAVATION SAFETY PROTECTION**  
CONTRACTOR AND/OR CONTRACTOR'S INDEPENDENTLY RETAINED EMPLOYEE OR STRUCTURAL DESIGN/ GEOTECHNICAL/ SAFETY/ EQUIPMENT CONSULTANT, IF ANY, SHALL REVIEW THESE PLANS AND ANY AVAILABLE GEOTECHNICAL INFORMATION AND THE ANTICIPATED INSTALLATION SITES WITHIN THE PROJECT WORK AREA IN ORDER TO IMPLEMENT CONTRACTOR'S TRENCH EXCAVATION SAFETY PROTECTION SYSTEMS, PROGRAMS AND/OR PROCEDURES FOR THE PROJECT DESCRIBED IN THE CONTRACT DOCUMENTS. THE CONTRACTOR'S IMPLEMENTATION OF THESE SYSTEMS, PROGRAMS AND/OR PROCEDURES SHALL PROVIDE FOR ADEQUATE TRENCH EXCAVATION SAFETY PROTECTION THAT COMPLY WITH AS A MINIMUM, OSHA STANDARDS FOR TRENCH EXCAVATIONS. SPECIFICALLY, CONTRACTOR AND/OR CONTRACTOR'S INDEPENDENTLY RETAINED EMPLOYEE OR SAFETY CONSULTANT SHALL IMPLEMENT A TRENCH SAFETY PROGRAM IN ACCORDANCE WITH OSHA STANDARDS GOVERNING THE PRESENCE AND ACTIVITIES OF INDIVIDUALS WORKING IN AND AROUND TRENCH EXCAVATION.

DATE	NO.	REVISION

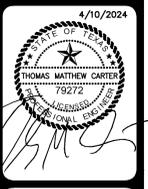

**PAPE-DAWSON ENGINEERS**  
2000 HW LOOP 410 | SAN ANTONIO, TX 78233 | 210.375.8000  
TEXAS ENGINEERING FIRM #0711 TEXAS SURVEYING FIRM #0089890

**TERALTA PHASE II**  
SAN ANTONIO, TEXAS  
SS LINE A - PLAN & PROFILE

PLAT NO.	160338
JOB NO.	8771-09
DATE	FEBRUARY 2024
DESIGNER	RH
CHECKED	EX DRAWN RH
SHEET	C6.20

**TCEQ - ORGANIZED SEWAGE COLLECTION SYSTEM GENERAL CONSTRUCTION NOTES**

- THIS ORGANIZED SEWAGE COLLECTION SYSTEM (SCS) MUST BE CONSTRUCTED IN ACCORDANCE WITH 30 TEXAS ADMINISTRATIVE CODE (TAC) 8213.01, THE TEXAS COMMISSION ON ENVIRONMENTAL QUALITY'S (TCEQ) EDWARDS AQUIFER RULES AND ANY LOCAL GOVERNMENT STANDARD SPECIFICATIONS.
- ALL CONTRACTORS CONDUCTING REGULATED ACTIVITIES ASSOCIATED WITH THIS PROPOSED REGULATED PROJECT MUST BE PROVIDED WITH COPIES OF THE SCS PLAN AND THE TCEQ LETTER INDICATING THE SPECIFIC CONDITIONS OF ITS APPROVAL. DURING THE REGULATION PERIOD, THE CONTRACTOR SHALL BE REQUIRED TO KEEP ON-SITE COPIES OF THE PLAN AND THE APPROVAL LETTER.
- A WRITTEN NOTICE OF CONSTRUCTION MUST BE SUBMITTED TO THE PRESIDING TCEQ REGIONAL OFFICE AT LEAST 48 HOURS PRIOR TO THE START OF ANY REGULATED ACTIVITIES. THIS NOTICE MUST INCLUDE:
  - THE NAME OF THE APPROVED PROJECT;
  - THE ACTIVITY START DATE; AND
  - THE CONTACT INFORMATION OF THE PRIME CONTRACTOR.
- ANY MODIFICATION TO THE ACTIVITIES DESCRIBED IN THE REFERENCED SCS APPLICATION FOLLOWING THE DATE OF APPROVAL MAY REQUIRE THE SUBMITTAL OF AN SCS APPLICATION TO MODIFY THIS APPROVAL, INCLUDING THE PAYMENT OF APPROPRIATE FEES AND ALL INFORMATION NECESSARY FOR ITS REVIEW AND APPROVAL.
- PRIOR TO BEGINNING ANY CONSTRUCTION ACTIVITY, ALL TEMPORARY EROSION AND SEDIMENTATION (EAS) CONTROL MEASURES MUST BE PROPERLY INSTALLED AND MAINTAINED IN ACCORDANCE WITH THE STANDARD SPECIFICATIONS. THESE CONTROLS MUST REMAIN IN PLACE UNTIL THE DISTURBED AREAS HAVE BEEN PERMANENTLY STABILIZED.
- IF ANY SENSITIVE FEATURES ARE DISCOVERED DURING THE WASTEWATER LINE TRENCHING ACTIVITIES, ALL NEAR THE SEWER LINE, THE CONTRACTOR MUST BE SUSPENDED IMMEDIATELY. THE APPLICANT MUST IMMEDIATELY NOTIFY THE APPROPRIATE REGIONAL OFFICE OF TCEQ OF THE FEATURE DISCOVERED. A GEOLOGIST'S ASSESSMENT OF THE LOCATION AND EXTENT OF THE FEATURE DISCOVERED MUST BE REPORTED TO THAT REGIONAL OFFICE IN WRITING AND THE APPLICANT MUST SUBMIT A PLAN FOR ENSURING THE STRUCTURAL INTEGRITY OF THE SEWER LINE OR FOR MODIFYING THE PROPOSED COLLECTION SYSTEM TRENCHING AROUND THE FEATURE DISCOVERED. THE EXECUTIVE DIRECTOR HAS SENSITIVE FEATURE MAY NOT PROCEED UNTIL THE EXECUTIVE DIRECTOR HAS REVIEWED AND APPROVED THE METHODS PROPOSED TO PROTECT THE SENSITIVE FEATURE AND THE EDWARDS AQUIFER FROM ANY POTENTIALLY ADVERSE IMPACTS TO WATER QUALITY WHILE MAINTAINING THE STRUCTURAL INTEGRITY OF THE LINE.
- SEWER LINES LOCATED WITHIN OR CROSSING THE 5-YEAR FLOODPLAIN OF A DRAINAGE WAY WILL BE PROTECTED FROM INUNDATION AND STREAM VELOCITIES WHICH COULD CAUSE EROSION AND SCOURING OF BACKFILL. THE TRENCH MUST BE CAPPED WITH CONCRETE TO PREVENT SCOURING OF BACKFILL, OR THE SEWER LINES MUST BE ENCASED IN CONCRETE. ALL CONCRETE SHALL HAVE A MINIMUM THICKNESS OF 8 INCHES.
- BLASTING PROCEDURES FOR PROTECTION OF EXISTING SEWER LINES AND OTHER UTILITIES WILL BE IN ACCORDANCE WITH THE NATIONAL FIRE PROTECTION ASSOCIATION CRITERIA. SAND IS NOT ALLOWED AS AN ALTERNATE BACKFILL IN TRENCHES THAT HAVE BEEN BLASTED. IF ANY EXISTING SEWER LINES OR OTHER UTILITIES, THE LINES MUST BE REPAIRED AND RETESTED.
- ALL MANHOLES CONSTRUCTED OR REHABILITATED ON THIS PROJECT MUST HAVE WATER TIGHT SIZE ON SIZE RESILIENT CONNECTIONS ALLOWING FOR DIFFERENTIAL SETTLEMENT. IF MANHOLES ARE CONSTRUCTED WITHIN THE 100-YEAR FLOODPLAIN, THE COVER AND RINGS ARE REQUIRED TO BE GASKETED. WHERE GASKETED MANHOLE COVERS ARE REQUIRED FOR MORE THAN THREE MANHOLES IN SEQUENCE OR FOR MORE THAN 1500 FEET, ALTERNATE MEANS OF VENTING WILL BE PROVIDED. BRICKS ARE NOT AN ACCEPTABLE CONSTRUCTION MATERIAL FOR ANY PORTION OF THE MANHOLE.
 

THE DIAMETER OF THE MANHOLES MUST HAVE A MINIMUM OF FOUR FEET AND THE MANHOLE FOR ENTRY AND EXIT MUST HAVE A MINIMUM CLEAR OPENING DIAMETER OF 30 INCHES. THESE DIMENSIONS ARE OTHER DETAILS SHOWING COMPLIANCE WITH THE COMMISSION'S RULES CONCERNING MANHOLES AND SEWER LINE/MANHOLE INVERTS DESCRIBED IN 30 TAC 8217.55 ARE INCLUDED ON PLAN SHEET \_\_\_\_\_.

IT IS SUGGESTED THAT ENTRANCE INTO MANHOLES IN EXCESS OF FOUR FEET DEEP BE ACCOMPLISHED BY MEANS OF A PORTABLE LADDER. THE INCLUSION OF STEPS IN A MANHOLE IS PROHIBITED.
- WHERE WATER LINES AND NEW SEWER LINE ARE INSTALLED WITH A SEPARATION DISTANCE CLOSER THAN NINE FEET, WATER LINES CROSSING WASTEWATER LINES, WATER LINES PARALLELING WASTEWATER LINES, OR WATER LINES NEXT TO MANHOLES (PIPE INSTALLATION MUST MEET THE REQUIREMENTS OF 30 TAC 8217.50) (PIPE DESIGN) AND 30 TAC 8206.4(4)(E) (WATER DISTRIBUTION).
- WHERE SEWER LINES DEVIATE FROM STRAIGHT ALIGNMENT AND UNIFORM GRADE ALL CURVATURE OF SEWER PIPE MUST BE ACHIEVED BY THE FOLLOWING PROCEDURE WHICH IS RECOMMENDED BY THE PIPE MANUFACTURER: \_\_\_\_\_
 

IF PIPE FLEXURE IS PROPOSED, THE FOLLOWING METHOD OF PREVENTING DEFLECTION OF THE JOINT MUST BE USED: \_\_\_\_\_

SPECIAL CARE MUST BE TAKEN TO ENSURE THAT THE JOINT IS PLACED IN THE CENTER OF THE TRENCH AND PROPERLY BEDDED IN ACCORDANCE WITH 30 TAC 8217.54.
- NEW SEWAGE COLLECTION SYSTEM LINES MUST BE CONSTRUCTED WITH STUB OUTS FOR THE CONNECTION OF ANTICIPATED EXTENSIONS. THE LOCATION OF SUCH STUB OUTS MUST BE MARKED ON THE GROUND SUCH THAT THEIR LOCATION CAN BE EASILY DETERMINED AT THE TIME OF CONNECTION OF THE EXTENSIONS. SUCH STUB OUTS MUST BE MANUFACTURED WYES OR TEES THAT ARE COMPATIBLE IN SIZE AND MATERIAL WITH BOTH THE SEWER LINE AND THE EXTENSION. AT THE TIME OF ORIGINAL CONSTRUCTION, NEW STUB-OUTS MUST BE CONSTRUCTED SUFFICIENTLY TO EXTEND BEYOND THE END OF THE STREET PAVEMENT. ALL STUB-OUTS MUST BE SEALED WITH A MANUFACTURED CAP TO PREVENT LEAKAGE. EXTENSIONS THAT WERE NOT ANTICIPATED AT THE TIME OF ORIGINAL CONSTRUCTION OR THAT ARE TO BE CONNECTED TO AN EXISTING SEWER LINE NOT FURNISHED WITH STUB OUTS MUST BE CONNECTED USING A MANUFACTURED SADDLE AND IN ACCORDANCE WITH ACCEPTED PLUMBING TECHNIQUES.
 

IF NO STUB-OUT IS PRESENT AN ALTERNATE METHOD OF JOINING LATERALS IS SHOWN IN THE DETAIL ON PLAN SHEET \_\_\_\_\_ OF \_\_\_\_\_ (FOR POTENTIAL FUTURE LATERALS).

THE PRIVATE SERVICE LATERAL STUB-OUTS MUST BE INSTALLED AS SHOWN ON THE PLAN AND PROFILE SHEETS ON PLAN SHEET \_\_\_\_\_ OF \_\_\_\_\_ AND MARKED AFTER BACKFILLING AS SHOWN IN THE DETAIL ON PLAN SHEET \_\_\_\_\_ OF \_\_\_\_\_.
- TRENCHING, BEDDING AND BACKFILL MUST CONFORM WITH 30 TAC 8217.54. THE BEDDING AND BACKFILL FOR FLEXIBLE PIPE MUST COMPLY WITH THE STANDARDS OF ASTM D-2321, CLASSES (A, B, II, OR III). RIGID PIPE BEDDING MUST COMPLY WITH THE REQUIREMENTS OF ASTM C 12 (CLASS A, B, OR C).
- SEWER LINES MUST BE TESTED FROM MANHOLE TO MANHOLE. WHEN A NEW SEWER LINE IS CONNECTED TO AN EXISTING STUB OR CLEAN-OUT, IT MUST BE TESTED FROM EXISTING MANHOLE TO NEW MANHOLE. IF A STUB OR CLEAN-OUT IS USED AT THE END OF THE PROPOSED SEWER LINE, NO PRIVATE SERVICE ATTACHMENTS MAY BE CONNECTED BETWEEN THE LAST MANHOLE AND THE CLEANOUT UNLESS IT CAN BE CERTIFIED AS CONFORMING WITH THE PROVISIONS OF 30 TAC 8213.5(C)(3)(E).
- ALL SEWER LINES MUST BE TESTED IN ACCORDANCE WITH 30 TAC 8217.57. THE ENGINEER MUST RETAIN COPIES OF ALL TEST RESULTS WHICH MUST BE MADE AVAILABLE TO THE EXECUTIVE DIRECTOR UPON REQUEST. THE ENGINEER MUST CERTIFY IN WRITING THAT ALL WASTEWATER LINES HAVE PASSED ALL REQUIRED TESTING TO THE APPROPRIATE REGIONAL OFFICE WITHIN 30 DAYS OF TEST COMPLETION AND PRIOR TO USE OF THE NEW COLLECTION SYSTEM. TESTING METHOD WILL BE:
  - FOR A COLLECTION SYSTEM PIPE THAT WILL TRANSPORT WASTEWATER BY GRAVITY FLOW, THE DESIGN MUST SPECIFY AN INFILTRATION AND EXFILTRATION TEST OR A LOW-PRESSURE AIR TEST. A TEST MUST CONFORM TO THE FOLLOWING REQUIREMENTS:
    - LOW PRESSURE AIR TEST.
  - A LOW PRESSURE AIR TEST MUST FOLLOW THE PROCEDURES DESCRIBED IN AMERICAN SOCIETY OF TESTING MATERIALS (ASTM) C-828, ASTM F-424, OR ASTM F-1417 OR OTHER PROCEDURE APPROVED BY THE EXECUTIVE DIRECTOR, EXCEPT AS TO TESTING TIMES AS REQUIRED IN TABLE C.3 IN SUBPARAGRAPH (C) OF THIS PARAGRAPH OR EQUATION C.3 IN SUBPARAGRAPH (IV) OF THIS PARAGRAPH.

(B) FOR SECTIONS OF COLLECTION SYSTEM PIPE LESS THAN 36 INCH AVERAGE INSIDE DIAMETER, THE FOLLOWING PROCEDURE MUST APPLY, UNLESS A PIPE IS TO BE TESTED AS REQUIRED BY PARAGRAPH (2) OF THIS SUBSECTION.

(1) A PIPE MUST BE PRESSURIZED TO 3.0 POUNDS PER SQUARE INCH (PSI) GREATER THAN THE PRESSURE EXERTED BY GROUNDWATER ABOVE THE PIPE.

(II) ONCE THE PRESSURE IS STABILIZED, THE MINIMUM TIME ALLOWABLE FOR THE PRESSURE TO DROP FROM 3.5 PSI GAUGE TO 2.5 PSI GAUGE IS COMPUTED FROM THE FOLLOWING EQUATION:

$$T = \frac{0.00499 \times D \times L \times K}{L \times Q}$$

WHERE: T = TIME FOR PRESSURE TO DROP 1.0 POUND PER SQUARE INCH  
 D = AVERAGE INSIDE PIPE DIAMETER IN INCHES  
 L = LENGTH OF LINE OF SAME SIZE BEING TESTED, IN FEET  
 Q = RATE OF LOSS, 0.0019 CUBIC FEET PER MINUTE PER SQUARE FOOT INTERNAL SURFACE

PIPE DIAMETER (INCHES)	MIN. TIME (SECONDS)	LENGTH FOR MIN. TIME (FEET)	TIME, LONGER LENGTH (SECONDS)
6	454	298	0.855(L)
8	567	239	2.374(L)
10	680	199	3.419(L)
12	800	159	5.342(L)
14	1020	133	7.693(L)
18	1190	114	10.471(L)
24	1360	100	13.676(L)
27	1530	88	17.309(L)
30	1700	80	21.369(L)
33	1870	72	25.851(L)

- PIPE DIAMETER MIN. TIME LENGTH FOR MIN. TIME, LONGER LENGTH (INCHES) (SECONDS) (FEET) (SECONDS)
- (G) SINCE A K VALUE OF LESS THAN 1.0 MAY NOT BE USED, THE MINIMUM TESTING TIME FOR EACH PIPE DIAMETER IS SHOWN IN THE FOLLOWING TABLE C.3.
- (H) AN OWNER MAY STOP A TEST IF NO PRESSURE LOSS HAS OCCURRED DURING THE FIRST 25% OF THE CALCULATED TESTING TIME.
- (I) IF ANY PRESSURE LOSS OR LEAKAGE HAS OCCURRED DURING THE FIRST 25% OF THE CALCULATED TESTING TIME, THE TEST MUST CONTINUE FOR THE ENTIRE TEST DURATION AS OUTLINED ABOVE OR UNTIL FAILURE.
- (J) WASTEWATER COLLECTION SYSTEM PIPES WITH A 27 INCH OR LARGER AVERAGE INSIDE DIAMETER MAY BE AIR TESTED AT EACH JOINT INSTEAD OF FOLLOWING THE PROCEDURES SET FORTH IN THIS SECTION.
- (K) A TESTING PROCEDURE FOR PIPE WITH AN INSIDE DIAMETER GREATER THAN 33 INCHES MUST BE APPROVED BY THE EXECUTIVE DIRECTOR.
- (L) INFILTRATION AND EXFILTRATION TESTS:
  - (1) THE TOTAL EXFILTRATION, AS DETERMINED BY A HYDROSTATIC HEAD TEST, MUST NOT EXCEED 90 GALLONS PER INCH OF DIAMETER PER MILE OF PIPE PER 24 HOURS AT A MINIMUM TEST HEAD OF 2.0 FEET ABOVE THE CROWN OF A PIPE AT AN UPSTREAM MANHOLE, OR AT LEAST TWO FEET ABOVE EXISTING GROUNDWATER LEVEL, WHICHEVER IS GREATER.
  - (2) AN OWNER SHALL USE AN INFILTRATION TEST IN LIEU OF AN EXFILTRATION TEST WHEN PIPES ARE INSTALLED BELOW THE GROUNDWATER LEVEL.
  - (3) THE TOTAL EXFILTRATION, AS DETERMINED BY A HYDROSTATIC HEAD TEST, MUST NOT EXCEED 50 GALLONS PER INCH DIAMETER PER MILE OF PIPE PER 24 HOURS AT A MINIMUM TEST HEAD OF TWO FEET ABOVE THE CROWN OF A PIPE AT AN UPSTREAM MANHOLE, OR AT LEAST TWO FEET ABOVE EXISTING GROUNDWATER LEVEL, WHICHEVER IS GREATER.
  - (4) THE QUANTITY OF INFILTRATION OR EXFILTRATION EXCEEDS THE MAXIMUM QUANTITY SPECIFIED, AN OWNER SHALL UNDERTAKE REMEDIAL ACTION IN ORDER TO REDUCE THE INFILTRATION OR EXFILTRATION TO WITHIN THE LIMITS SPECIFIED, AN OWNER SHALL RETEST A PIPE FOLLOWING A REMEDIATION ACTION.
- (M) IF A GRAVITY COLLECTION PIPE IS COMPOSED OF FLEXIBLE PIPE, DEFLECTION TESTING IS ALSO REQUIRED. THE FOLLOWING PROCEDURES MUST BE FOLLOWED:
  - (1) FOR A COLLECTION PIPE WITH INSIDE DIAMETER LESS THAN 27 INCHES, DEFLECTION MEASUREMENT REQUIRES A RIGID MANDREL.
  - (2) A MANDREL SIZING:
    - (a) A RIGID MANDREL MUST HAVE AN OUTSIDE DIAMETER (OD) NOT LESS THAN 90% OF THE BASE INSIDE DIAMETER (ID) OR AVERAGE ID OF A PIPE, AS SPECIFIED IN THE APPROPRIATE STANDARD. THE ASTM, AMERICAN WATER WORKS ASSOCIATION, UNI-BELL, OR AMERICAN NATIONAL STANDARDS INSTITUTE, OR ANY OTHER STANDARD, MAY BE USED.
    - (b) IF A MANDREL SIZING DIAMETER IS NOT SPECIFIED IN THE APPROPRIATE STANDARD, THE MANDREL MUST HAVE AN OD EQUAL TO THE ID OF A PIPE. IN THIS CASE, THE ID OF THE PIPE, FOR THE PURPOSE OF DETERMINING THE OD OF THE MANDREL, MUST EQUAL BE THE AVERAGE OUTSIDE DIAMETER MINUS TWO MINIMUM WALL THICKNESSES FOR TWO CONTROLLED PIPE AND THE AVERAGE INSIDE DIAMETER FOR D CONTROLLED PIPE.
  - (3) ALL DIMENSIONS MUST MEET THE APPROPRIATE STANDARD.
  - (4) MANDREL DESIGN:
    - (a) A RIGID MANDREL MUST BE CONSTRUCTED OF A METAL OR A RIGID PLASTIC MATERIAL THAT CAN WITHSTAND 200 PSI WITHOUT BEING DEFORMED.
    - (b) A MANDREL MUST HAVE NINE OR MORE ODD NUMBER OF RUNNERS OR LEGS.
    - (c) A BARREL SECTION LENGTH MUST EQUAL AT LEAST 75% OF THE INSIDE DIAMETER OF A PIPE.
    - (d) EACH SIZE MANDREL MUST USE A SEPARATE PROVING RING.
  - (5) METHOD OPTIONS:
    - (a) AN ADJUSTABLE OR FLEXIBLE MANDREL IS PROHIBITED.
    - (b) A TEST MAY NOT USE TELEVISION INSPECTION AS A SUBSTITUTE FOR A DEFLECTION TEST.
    - (c) IF REQUESTED, THE EXECUTIVE DIRECTOR MAY APPROVE THE USE OF A TEST METHOD OTHER THAN A MANDREL WITH REMOVABLE LEGS OR RUNNERS ON A CASE-BY-CASE BASIS.
  - (6) FOR A GRAVITY COLLECTION SYSTEM PIPE WITH AN INSIDE DIAMETER 27 INCHES AND GREATER, OTHER TEST METHODS MAY BE USED TO DETERMINE VERTICAL DEFLECTION. A DEFLECTION TEST METHOD MUST BE ACCURATE TO WITHIN PLUS OR MINUS 0.2% DEFLECTION.
  - (7) AN OWNER SHALL NOT CONDUCT A DEFLECTION TEST UNTIL AT LEAST 30 DAYS AFTER THE FINAL BACKFILL.
  - (8) GRAVITY COLLECTION SYSTEM PIPE DEFLECTION MUST NOT EXCEED FIVE PERCENT (5%).
  - (9) IF A PIPE SECTION FAILS A DEFLECTION TEST, AN OWNER SHALL CORRECT THE PROBLEM AND CONDUCT A SECOND TEST AFTER THE FINAL BACKFILL HAS BEEN IN PLACE AT LEAST 30 DAYS.
- ALL MANHOLES MUST BE TESTED TO MEET OR EXCEED THE REQUIREMENTS OF 30 TAC 8217.58.
  - (a) ALL MANHOLES MUST PASS A LEAKAGE TEST.
  - (b) AN OWNER SHALL TEST EACH MANHOLE (AFTER ASSEMBLY AND BACKFILLING) FOR LEAKAGE, SEPARATE AND INDEPENDENT OF THE COLLECTION SYSTEM PIPES, BY HYDROSTATIC EXFILTRATION TESTING, VACUUM TESTING, OR OTHER METHOD APPROVED BY THE EXECUTIVE DIRECTOR.
  - (1) HYDROSTATIC TESTING:
    - (A) THE MAXIMUM LEAKAGE FOR HYDROSTATIC TESTING OR ANY ALTERNATIVE TEST METHODS IS 0.025 GALLONS PER FOOT DIAMETER PER FOOT OF MANHOLE DEPTH PER HOUR.
    - (B) TO PERFORM A HYDROSTATIC EXFILTRATION TEST, AN OWNER SHALL SEAL ALL WASTEWATER PIPES COMING INTO A MANHOLE WITH AN INTERNAL PIPE PLUG, FILL THE MANHOLE WITH WATER, AND MAINTAIN THE TEST FOR AT LEAST ONE HOUR.
    - (C) A TEST FOR CONCRETE MANHOLES MAY USE A 24-HOUR LIFTING PERIOD BEFORE TESTING TO ALLOW SATURATION OF THE CONCRETE.
  - (2) VACUUM TESTING:
    - (A) TO PERFORM A VACUUM TEST, AN OWNER SHALL PLUG ALL LIFT HOLES AND EXTERIOR JOINTS WITH A NON-SHRINK GROUT AND PLUG ALL PIPES ENTERING A MANHOLE.
    - (B) NO GROUT MUST BE PLACED IN HORIZONTAL JOINTS BEFORE TESTING.
    - (C) STUB-OUTS, MANHOLE BOOTTS, AND PIPE PLUGS MUST BE SECURED TO PREVENT MOVEMENT WHILE A VACUUM IS DRAWN.
    - (D) AN OWNER SHALL USE A MINIMUM 60 INCH-LB TORQUE WRENCH TO TIGHTEN THE EXTERNAL CLAMPS THAT SECURE A TEST COVER TO THE TOP OF A MANHOLE.
    - (E) A TEST HEAD MUST BE PLACED AT THE INSIDE OF THE TOP OF A CONE SECTION, AND THE SEAL INFILATED IN ACCORDANCE WITH THE MANUFACTURER'S RECOMMENDATIONS.
    - (F) THERE MUST BE A VACUUM OF 10 INCHES OF MERCURY INSIDE A MANHOLE TO PERFORM A VALID TEST.
    - (G) A TEST DOES NOT BEGIN UNTIL AFTER THE VACUUM PUMP IS OFF.
    - (H) A MANHOLE PASSES THE TEST IF AFTER 2.0 MINUTES AND WITH ALL VALVES CLOSED, THE VACUUM IS AT LEAST 9.0 INCHES OF MERCURY.
- ALL PRIVATE SERVICE LATERALS MUST BE INSPECTED AND CERTIFIED IN ACCORDANCE WITH 30 TAC 8213.5(C)(3)(E). AFTER INSTALLATION OF AND, PRIOR TO COVERING AND CONNECTING A PRIVATE SERVICE LATERAL, TO AN EXISTING ORGANIZED SEWAGE COLLECTION SYSTEM, A TEXAS LICENSED PROFESSIONAL ENGINEER OR REGISTERED SANITARIAN OR APPROPRIATE CITY INSPECTOR MUST VISUALLY INSPECT THE PRIVATE SERVICE LATERAL AND THE CONNECTION TO THE SEWAGE COLLECTION SYSTEM AND CERTIFY THAT IT IS CONSTRUCTED IN CONFORMITY WITH THE APPLICABLE PROVISIONS OF THIS SECTION. THE OWNER OF THE COLLECTION SYSTEM MUST MAINTAIN SUCH CERTIFICATIONS FOR FIVE YEARS AND FORWARD COPIES TO THE APPROPRIATE REGIONAL OFFICE UPON REQUEST. CONNECTIONS MAY ONLY BE MADE TO AN APPROVED SEWAGE COLLECTION SYSTEM.

THESE GENERAL CONSTRUCTION NOTES MUST BE INCLUDED ON THE CONSTRUCTION PLANS PROVIDED TO THE CONTRACTOR AND ALL SUBCONTRACTORS.

AUSTIN REGIONAL OFFICE  
 1921 CEDAR BEND, SUITE 150  
 AUSTIN, TEXAS 78758-5336  
 PHONE (512) 339-3929  
 FAX (512) 339-3795

SAN ANTONIO REGIONAL OFFICE  
 14250 JUDSON ROAD  
 SAN ANTONIO, TEXAS 78233-4480  
 PHONE (210) 490-3096  
 FAX (210) 545-4329

**SAWS NOTES FOR EDWARDS AQUIFER RECHARGE ZONE**

(1) THIS PROJECT IS WITHIN THE EDWARDS AQUIFER RECHARGE ZONE. ALL MATERIAL AND CONSTRUCTION PROCEDURES WITHIN THE SCOPE OF THIS CONTRACT SHALL BE APPROVED BY THE SAN ANTONIO WATER SYSTEM (SAWS) AND COMPLY WITH CURRENT SPECIFICATIONS.

- THE CONTRACTOR SHALL NOT PROCEED WITH ANY PIPE INSTALLATION WORK UNTIL THEY OBTAIN A COPY OF THE APPROVED G.C.P. FROM THE CONSULTANT AND THE SAN ANTONIO WATER SYSTEM (SAWS) AND COMPLY WITH CURRENT SPECIFICATIONS.
- THE CONTRACTOR SHALL MAINTAIN ACCESS TO ALL EXISTING SANITARY SEWERS AT ALL TIMES DURING CONSTRUCTION.
- THE LOCATIONS AND DEPTHS OF EXISTING UTILITIES, TO INCLUDE SERVICE LATERALS SHOWN IN THESE PLANS ARE APPROXIMATE ONLY. IT SHALL BE THE CONTRACTOR'S RESPONSIBILITY TO LOCATE UTILITY SERVICE LINES 48 HOURS PRIOR TO EXCAVATION AND TO PROTECT THE SAME DURING CONSTRUCTION.
- SAWS ANTIOX WATER SYSTEM 233-2010 (WATER, SEWER & RECYCLED WATER)
  - 1-800-545-6005
  - 1-800-545-6005
  - 1-800-545-6005
  - 1-800-545-6005
  - 1-800-545-6005

5. ALL WORK IN TEXAS HIGHWAY DEPARTMENT AND BEXAR COUNTY RIGHT-OF-WAY SHALL BE DONE IN ACCORDANCE WITH RESPECTIVE WITH RESPECTIVE CONSTRUCTION SPECIFICATIONS AND PERMIT.

6. DUE TO FEDERAL REGULATIONS TITLE 49, PART 192.161, CITY PUBLIC SERVICE MUST MAINTAIN ACCESS TO GAS VALVES AT ALL TIMES. THE CONTRACTOR MUST PROTECT AND WORK AROUND GAS VALVES THAT ARE IN THE PROJECT AREAS.

7. ALL MANHOLES SHALL BE CONSTRUCTED SO THAT THE TOP OF THE RING IS AT LEAST FOUR INCHES ABOVE THE FINISHED GRADE OF THE SURROUNDING GROUND EXCEPT WHEN LOCATED IN PAVED AREAS. IN PAVED AREAS, THE MANHOLE RING SHALL BE FLUSH WITH THE FINISHED GRADE.

8. ON ANY MANHOLES TO BE ABANDONED, THE RINGS AND COVER SHALL BE SALVAGED IN ACCORDANCE WITH THE STANDARD SPECIFICATIONS, ITEM 86Z, AND THE HOLE BACKFILLED TO THE SATISFACTION OF THE INSPECTOR.

9. THE USE OF ASBESTOS CEMENT PIPE WILL BE PROHIBITED UNDER THIS CONTRACT. ALL DUCTILE IRON PIPE USED IN THIS SYSTEM SHALL BE CORROSION PROTECTED ON BOTH THE INTERNAL AND EXTERIOR SURFACES. ALL CORROSION PROTECTION SHALL BE APPLIED AND INSTALLED IN SUCH A MANNER AS TO MAINTAIN A CONTINUOUSLY PROTECTED SURFACE AFTER FINAL PIPE INSTALLATION.

10. ALL PVC SEWER PIPE WITH OVER 14 FEET OF COVER SHALL BE EXTRA STRENGTH, MINIMUM PIPE STIFFNESS OF 115 PFI.

11. SEWER PIPE CONNECTIONS TO PRE-CAST MANHOLES WILL BE COMPRESSION JOINTS AS APPROVED BY SAWS. MECHANICAL JOINT "BOOT TYPE" CONNECTIONS ALONE WILL NOT BE ALLOWED. "BOOT TYPE JOINTS" MAY BE USED IN CONJUNCTION WITH COMPRESSION JOINTS AS APPROVED BY SAWS. ANY CHANGES FROM THESE METHODS MUST BE APPROVED BY SAWS.

12. ALL RESIDENTIAL SEWER SERVICE LATERAL SHALL BE EXTENDED TO THE PROPERTY LINE AND CAPPED AND SEALED. (ITEM, NO. DD-854-01).

13. WHERE REQUIRED, CONCRETE ENCASEMENT SHALL BE PLACED FOR FULL WIDTH OF THE TRENCH TO A PLANE 6" ABOVE THE TOP OF THE PIPE, WITH PAY LIMITS AS SHOWN ON THE ITEM NO. DD-858-01.

14. A MINIMUM OF 3 FEET OF COVER IS TO BE MAINTAINED OVER THE SANITARY SEWER MAIN AND LATERALS AT SUBGRADE, OTHERWISE CONCRETE ENCASEMENT WILL BE REQUIRED.

15. NO BLASTING SHALL BE PERFORMED WITHIN 75 FEET OF EXISTING UTILITIES.

16. CONTRACTOR IS RESPONSIBLE FOR REMOVAL OF ALL WASTE MATERIALS UPON PROJECT COMPLETION. THE CONTRACTOR SHALL NOT PERMANENTLY PLACE ANY WASTE MATERIALS IN THE 100-YEAR FLOOD PLAN WITHOUT FIRST OBTAINING AN APPROVAL FLOOD PLAN DEVELOPMENT PERMIT.

17. THE CONTRACTOR SHALL NOT PLACE ANY MATERIALS ON THE RECHARGE ZONE OF THE EDWARDS AQUIFER WITHOUT AN APPROVED WATER POLLUTION ABATEMENT PLAN FROM THE TCEQ.

18. CONTRACTOR AND/OR CONTRACTOR'S INDEPENDENTLY RETAINED EMPLOYEE OR STRUCTURAL DESIGN/GEOTECHNICAL/SAFETY/EQUIPMENT CONSULTANT, IF ANY, SHALL REVIEW THESE PLANS AND AVAILABLE GEOTECHNICAL INFORMATION AND THE ANTICIPATED INSTALLATION SITE(S) WITHIN THE PROJECT WORK AREA IN ORDER TO IMPLEMENT CONTRACTOR'S TRENCH EXCAVATION SAFETY PROTECTION SYSTEMS, PROGRAMS AND/OR PROCEDURES. THE CONTRACTOR'S IMPLEMENTATION OF THE SYSTEMS, PROGRAMS AND/OR PROCEDURES SHALL PROVIDE FOR ADEQUATE TRENCH EXCAVATION SAFETY PROTECTION THAT COMPLIES WITH AS A MINIMUM, OSHA STANDARDS FOR TRENCH EXCAVATIONS. SPECIFICALLY, CONTRACTOR AND/OR CONTRACTOR'S INDEPENDENTLY RETAINED EMPLOYEE OR SAFETY CONSULTANT SHALL IMPLEMENT A TRENCH SAFETY PROGRAM IN ACCORDANCE WITH OSHA STANDARDS TO GOVERNING THE PRESENCE AND ACTIVITIES OF INDIVIDUALS WORKING IN AND AROUND TRENCH EXCAVATION.

19. THE CONTRACTOR SHALL NOT PROCEED WITH ANY PIPE INSTALLATION WORK UNTIL THEY OBTAIN A COPY OF THE APPROVED G.C.P. FROM THE CONSULTANT AND THE SAN ANTONIO WATER SYSTEM (SAWS) AND COMPLY WITH CURRENT SPECIFICATIONS.

20. ALL TEMPORARY EROSION AND SEDIMENTATION CONTROLS MUST BE INSTALLED PRIOR TO CONSTRUCTION, SHALL BE MAINTAINED DURING CONSTRUCTION, AND SHALL BE REMOVED WHEN VEGETATION IS ESTABLISHED AND THE CONSTRUCTION AREA IS STABILIZED. ADDITIONAL PROTECTION MAY BE NECESSARY IF EXCESSIVE SOLIDS ARE BEING DISCHARGED FROM THE SITE.

21. PLACEMENT OF SUCH CONTROLS SHALL BE IN ACCORDANCE WITH THE CONSTRUCTION PLANS. ACTUAL LOCATIONS MAY VARY SLIGHTLY FROM THE PLANS, BUT WILL BE VERIFIED BY THE ENGINEER/INSPECTOR IN THE FIELD PRIOR TO SEWER LINE CONSTRUCTION. THE CONTRACTOR AND CITY INSPECTOR SHALL INSPECT THE CONTROLS AT WEEKLY INTERVALS AND AFTER EVERY SIGNIFICANT RAINFALL TO INSURE SIGNIFICANT DISTURBANCE TO THE STRUCTURES HAS NOT OCCURRED. SEDIMENT DEPOSITED AFTER A SIGNIFICANT RAINFALL SHALL BE REMOVED FROM THE SITE OR PLACED IN AN APPROVED DESIGNATED SOIL DISPOSAL AREA.

22. A DEFLECTION TEST SHALL BE PERFORMED ON ALL FLEXIBLE PIPE. THE TEST SHALL BE CONDUCTED AFTER INITIAL BACKFILL HAS BEEN IN PLACE AT LEAST 30 DAYS. ITEM NO. 849-23. ALL MAINS MUST PASS AIR TESTING PER ITEM NO. 849 IN THE STANDARD SPECIFICATIONS PRIOR TO ACCEPTANCE BY THE SAN ANTONIO WATER SYSTEM.

24. ALL MAINS MUST COMPLY WITH ITEM NO. 868 OF SEWER MAIN CLEANING.

25. WATER JETTING THE BACKFILL WITHIN A STREET WILL NOT BE PERMITTED. SANITARY SEWER TRENCHES SUBJECT TO TRAFFIC SHALL CONFORM TO THE CITY OF SAN ANTONIO STANDARD SPECIFICATIONS FOR PUBLIC WORKS CONSTRUCTION AND SAWS ITEM 804.

26. SANITARY SEWER MAIN CONNECTIONS MADE DIRECTLY TO EXISTING MANHOLES WILL REQUIRE SUCCESSFUL TESTING OF THE MANHOLES IN ACCORDANCE WITH THE STANDARD SPECIFICATIONS ITEM 849.

27. AFTER CONSTRUCTION, TESTING WILL BE DONE BY T.V. CAMERA BY THE CONTRACTOR AND OBSERVED BY INSPECTOR, AND WASTEWATER ENGINEERING CONSULTANT. THE CAMERA IS RUN THROUGH THE LINES. ANY ABNORMALITIES SUCH AS BROKEN PIPE OR MALIGNED JOINTS, MUST BE REPAIRED BY THE CONTRACTOR AT HIS EXPENSE.

28. A COPY OF ALL TESTING REPORTS SHALL BE FORWARDED TO THE SAN ANTONIO WATER SYSTEM CONSTRUCTION INSPECTION DIVISION.

29. NO EXTRA PAYMENT SHALL BE ALLOWED FOR WORK CALLED FOR ON THE PLANS BUT NOT INCLUDED ON THE BID SCHEDULE. THIS INCIDENTAL WORK WILL BE REQUIRED AND SHALL BE INCLUDED UNDER THE PAY ITEM TO WHICH IT RELATES.

30. THE DEVELOPER DEDICATES THE SANITARY SEWER MAINS UPON COMPLETION BY THE DEVELOPER AND ACCEPTANCE BY THE SAN ANTONIO WATER SYSTEM. THE SAN ANTONIO WATER SYSTEM WILL OWN AND MAINTAIN SAID SANITARY SEWER MAINS WHICH ARE LOCATED WITHIN THIS PARTICULAR SUBDIVISION. (AS APPLICABLE)

31. THE DEVELOPER WILL BE RESPONSIBLE FOR THE LIFT STATION MAINTENANCE FEE IN EFFECT AT THE TIME OF CERTIFICATION, THE CURRENT LIFT STATION MAINTENANCE FEE PER LIFT STATION WILL BE COLLECTED PRIOR TO PLANT RECORDATION.

32. WORK COMPLETED BY THE CONTRACTOR WHICH HAS NOT RECEIVED A GENERAL CONSTRUCTION PERMIT OR THE CONSENT OF THE SAN ANTONIO WATER SYSTEM CONSTRUCTION INSPECTION DIVISION WILL BE SUBJECT TO REMOVAL AND REPLACEMENT BY AND AT THE EXPENSE OF THE CONTRACTOR.

19. A. THE TEXAS COMMISSION ON ENVIRONMENTAL QUALITY AND ENVIRONMENTAL PROTECTION AGENCY (EPA) REQUIRE EROSION AND SEDIMENTATION CONTROL FOR CONSTRUCTION OF SEWER COLLECTION SYSTEMS. DEVELOPER OR AUTHORIZED REPRESENTATIVE SHALL PROVIDE EROSION AND SEDIMENTATION CONTROL AS NOTED ON THE PROJECT'S PLAN AND PROFILE SHEETS.

B. AT A MINIMUM THESE CONTROLS SHALL CONSIST OF ROCK BERMS AND/OR SILT FENCES CONSTRUCTED PARALLEL TO AND DOWN GRADIENT FROM THE TRENCHES. THE ROCK BERM OR SILT FENCES SHALL BE INSTALLED IN A MANNER SUCH THAT ANY RAINFALL RUNOFF SHALL BE FILTERED. HAY BALES SHALL NOT BE USED FOR TEMPORARY EROSION AND SEDIMENTATION CONTROL.

20. ALL TEMPORARY EROSION AND SEDIMENTATION CONTROLS MUST BE INSTALLED PRIOR TO CONSTRUCTION, SHALL BE MAINTAINED DURING CONSTRUCTION, AND SHALL BE REMOVED WHEN VEGETATION IS ESTABLISHED AND THE CONSTRUCTION AREA IS STABILIZED. ADDITIONAL PROTECTION MAY BE NECESSARY IF EXCESSIVE SOLIDS ARE BEING DISCHARGED FROM THE SITE.

21. PLACEMENT OF SUCH CONTROLS SHALL BE IN ACCORDANCE WITH THE CONSTRUCTION PLANS. ACTUAL LOCATIONS MAY VARY SLIGHTLY FROM THE PLANS, BUT WILL BE VERIFIED BY THE ENGINEER/INSPECTOR IN THE FIELD PRIOR TO SEWER LINE CONSTRUCTION. THE CONTRACTOR AND CITY INSPECTOR SHALL INSPECT THE CONTROLS AT WEEKLY INTERVALS AND AFTER EVERY SIGNIFICANT RAINFALL TO INSURE SIGNIFICANT DISTURBANCE TO THE STRUCTURES HAS NOT OCCURRED. SEDIMENT DEPOSITED AFTER A SIGNIFICANT RAINFALL SHALL BE REMOVED FROM THE SITE OR PLACED IN AN APPROVED DESIGNATED SOIL DISPOSAL AREA.

22. A DEFLECTION TEST SHALL BE PERFORMED ON ALL FLEXIBLE PIPE. THE TEST SHALL BE CONDUCTED AFTER INITIAL BACKFILL HAS BEEN IN PLACE AT LEAST 30 DAYS. ITEM NO. 849-23. ALL MAINS MUST PASS AIR TESTING PER ITEM NO. 849 IN THE STANDARD SPECIFICATIONS PRIOR TO ACCEPTANCE BY THE SAN ANTONIO WATER SYSTEM.

24. ALL MAINS MUST COMPLY WITH ITEM NO. 868 OF SEWER MAIN CLEANING.

25. WATER JETTING THE BACKFILL WITHIN A STREET WILL NOT BE PERMITTED. SANITARY SEWER TRENCHES SUBJECT TO TRAFFIC SHALL CONFORM TO THE CITY OF SAN ANTONIO STANDARD SPECIFICATIONS FOR PUBLIC WORKS CONSTRUCTION AND SAWS ITEM 804.

26. SANITARY SEWER MAIN CONNECTIONS MADE DIRECTLY TO EXISTING MANHOLES WILL REQUIRE SUCCESSFUL TESTING OF THE MANHOLES IN ACCORDANCE WITH THE STANDARD SPECIFICATIONS ITEM 849.

27. AFTER CONSTRUCTION, TESTING WILL BE DONE BY T.V. CAMERA BY THE CONTRACTOR AND OBSERVED BY INSPECTOR, AND WASTEWATER ENGINEERING CONSULTANT. THE CAMERA IS RUN THROUGH THE LINES. ANY ABNORMALITIES SUCH AS BROKEN PIPE OR MALIGNED JOINTS, MUST BE REPAIRED BY THE CONTRACTOR AT HIS EXPENSE.

28. A COPY OF ALL TESTING REPORTS SHALL BE FORWARDED TO THE SAN ANTONIO WATER SYSTEM CONSTRUCTION INSPECTION DIVISION.

29. NO EXTRA PAYMENT SHALL BE ALLOWED FOR WORK CALLED FOR ON THE PLANS BUT NOT INCLUDED ON THE BID SCHEDULE. THIS INCIDENTAL WORK WILL BE REQUIRED AND SHALL BE INCLUDED UNDER THE PAY ITEM TO WHICH IT RELATES.

30. THE DEVELOPER DEDICATES THE SANITARY SEWER MAINS UPON COMPLETION BY THE DEVELOPER AND ACCEPTANCE BY THE SAN ANTONIO WATER SYSTEM. THE SAN ANTONIO WATER SYSTEM WILL OWN AND MAINTAIN SAID SANITARY SEWER MAINS WHICH ARE LOCATED WITHIN THIS PARTICULAR SUBDIVISION. (AS APPLICABLE)

31. THE DEVELOPER WILL BE RESPONSIBLE FOR THE LIFT STATION MAINTENANCE FEE IN EFFECT AT THE TIME OF CERTIFICATION, THE CURRENT LIFT STATION MAINTENANCE FEE PER LIFT STATION WILL BE COLLECTED PRIOR TO PLANT RECORDATION.

32. WORK COMPLETED BY THE CONTRACTOR WHICH HAS NOT RECEIVED A GENERAL CONSTRUCTION PERMIT OR THE CONSENT OF THE SAN ANTONIO WATER SYSTEM CONSTRUCTION INSPECTION DIVISION WILL BE SUBJECT TO REMOVAL AND REPLACEMENT BY AND AT THE EXPENSE OF THE CONTRACTOR.

33. THE DEVELOPER WILL BE RESPONSIBLE FOR THE LIFT STATION MAINTENANCE FEE IN EFFECT AT THE TIME OF CERTIFICATION, THE CURRENT LIFT STATION MAINTENANCE FEE PER LIFT STATION WILL BE COLLECTED PRIOR TO PLANT RECORDATION.

34. A MINIMUM OF 3 FEET OF COVER IS TO BE MAINTAINED OVER THE SANITARY SEWER MAIN AND LATERALS AT SUBGRADE, OTHERWISE CONCRETE ENCASEMENT WILL BE REQUIRED.

35. NO BLASTING SHALL BE PERFORMED WITHIN 75 FEET OF EXISTING UTILITIES.

36. CONTRACTOR IS RESPONSIBLE FOR REMOVAL OF ALL WASTE MATERIALS UPON PROJECT COMPLETION. THE CONTRACTOR SHALL NOT PERMANENTLY PLACE ANY WASTE MATERIALS IN THE 100-YEAR FLOOD PLAN WITHOUT FIRST OBTAINING AN APPROVAL FLOOD PLAN DEVELOPMENT PERMIT.

37. THE CONTRACTOR SHALL NOT PLACE ANY MATERIALS ON THE RECHARGE ZONE OF THE EDWARDS AQUIFER WITHOUT AN APPROVED WATER POLLUTION ABATEMENT PLAN FROM THE TCEQ.

38. CONTRACTOR AND/OR CONTRACTOR'S INDEPENDENTLY RETAINED EMPLOYEE OR STRUCTURAL DESIGN/GEOTECHNICAL/SAFETY/EQUIPMENT CONSULTANT, IF ANY, SHALL REVIEW THESE PLANS AND AVAILABLE GEOTECHNICAL INFORMATION AND THE ANTICIPATED INSTALLATION SITE(S) WITHIN THE PROJECT WORK AREA IN ORDER TO IMPLEMENT CONTRACTOR'S TRENCH EXCAVATION SAFETY PROTECTION SYSTEMS, PROGRAMS AND/OR PROCEDURES. THE CONTRACTOR'S IMPLEMENTATION OF THE SYSTEMS, PROGRAMS AND/OR PROCEDURES SHALL PROVIDE FOR ADEQUATE TRENCH EXCAVATION SAFETY PROTECTION THAT COMPLIES WITH AS A MINIMUM, OSHA STANDARDS FOR TRENCH EXCAVATIONS. SPECIFICALLY, CONTRACTOR AND/OR CONTRACTOR'S INDEPENDENTLY RETAINED EMPLOYEE OR SAFETY CONSULTANT SHALL IMPLEMENT A TRENCH SAFETY PROGRAM IN ACCORDANCE WITH OSHA STANDARDS TO GOVERNING THE PRESENCE AND ACTIVITIES OF INDIVIDUALS WORKING IN AND AROUND TRENCH EXCAVATION.

39. THE CONTRACTOR SHALL NOT PROCEED WITH ANY PIPE INSTALLATION WORK UNTIL THEY OBTAIN A COPY OF THE APPROVED G.C.P. FROM THE CONSULTANT AND THE SAN ANTONIO WATER SYSTEM (SAWS) AND COMPLY WITH CURRENT SPECIFICATIONS.

40. ALL TEMPORARY EROSION AND SEDIMENTATION CONTROLS MUST BE INSTALLED PRIOR TO CONSTRUCTION, SHALL BE MAINTAINED DURING CONSTRUCTION, AND SHALL BE REMOVED WHEN VEGETATION IS ESTABLISHED AND THE CONSTRUCTION AREA IS STABILIZED. ADDITIONAL PROTECTION MAY BE NECESSARY IF EXCESSIVE SOLIDS ARE BEING DISCHARGED FROM THE SITE.

41. PLACEMENT OF SUCH CONTROLS SHALL BE IN ACCORDANCE WITH THE CONSTRUCTION PLANS. ACTUAL LOCATIONS MAY VARY SLIGHTLY FROM THE PLANS, BUT WILL BE VERIFIED BY THE ENGINEER/INSPECTOR IN THE FIELD PRIOR TO SEWER LINE CONSTRUCTION. THE CONTRACTOR AND CITY INSPECTOR SHALL INSPECT THE CONTROLS AT WEEKLY INTERVALS AND AFTER EVERY SIGNIFICANT RAINFALL TO INSURE SIGNIFICANT DISTURBANCE TO THE STRUCTURES HAS NOT OCCURRED. SEDIMENT DEPOSITED AFTER A SIGNIFICANT RAINFALL SHALL BE REMOVED FROM THE SITE OR PLACED IN AN APPROVED DESIGNATED SOIL DISPOSAL AREA.

42. A DEFLECTION TEST SHALL BE PERFORMED ON ALL FLEXIBLE PIPE. THE TEST SHALL BE CONDUCTED AFTER INITIAL BACKFILL HAS BEEN IN PLACE AT LEAST 30 DAYS. ITEM NO. 849-23. ALL MAINS MUST PASS AIR TESTING PER ITEM NO. 849 IN THE STANDARD SPECIFICATIONS PRIOR TO ACCEPTANCE BY THE SAN ANTONIO WATER SYSTEM.

44. ALL MAINS MUST COMPLY WITH ITEM NO. 868 OF SEWER MAIN CLEANING.

45. WATER JETTING THE BACKFILL WITHIN A STREET WILL NOT BE PERMITTED. SANITARY SEWER TRENCHES SUBJECT TO TRAFFIC SHALL CONFORM TO THE CITY OF SAN ANTONIO STANDARD SPECIFICATIONS FOR PUBLIC WORKS CONSTRUCTION AND SAWS ITEM 804.

46. SANITARY SEWER MAIN CONNECTIONS MADE DIRECTLY TO EXISTING MANHOLES WILL REQUIRE SUCCESSFUL TESTING OF THE MANHOLES IN ACCORDANCE WITH THE STANDARD SPECIFICATIONS ITEM 849.

47. AFTER CONSTRUCTION, TESTING WILL BE DONE BY T.V. CAMERA BY THE CONTRACTOR AND OBSERVED BY INSPECTOR, AND WASTEWATER ENGINEERING CONSULTANT. THE CAMERA IS RUN THROUGH THE LINES. ANY ABNORMALITIES SUCH AS BROKEN PIPE OR MALIGNED JOINTS, MUST BE REPAIRED BY THE CONTRACTOR AT HIS EXPENSE.

48.

- A WRITTEN NOTICE OF CONSTRUCTION MUST BE SUBMITTED TO THE TCEQ REGIONAL OFFICE AT LEAST 48 HOURS PRIOR TO THE START OF ANY REGULATED ACTIVITIES. THIS NOTICE MUST INCLUDE:
  - THE NAME OF THE APPROVED PROJECT;
  - THE ACTIVITY START DATE; AND
  - THE CONTACT INFORMATION OF THE PRIME CONTRACTOR.
- ALL CONTRACTORS CONDUCTING REGULATED ACTIVITIES ASSOCIATED WITH THIS PROJECT MUST BE PROVIDED WITH COMPLETE COPIES OF THE APPROVED WATER POLLUTION ABATEMENT PLAN (WPAP) AND THE TCEQ LETTER INDICATING THE SPECIFIC CONDITIONS OF ITS APPROVAL. DURING THE COURSE OF THESE REGULATED ACTIVITIES, THE CONTRACTORS ARE REQUIRED TO KEEP ON-SITE COPIES OF THE APPROVED PLAN AND APPROVAL LETTER.
- IF ANY SENSITIVE FEATURE(S) (CAVES, SOLUTION CAVITY, SINK HOLE, ETC.) IS DISCOVERED DURING CONSTRUCTION, ALL REGULATED ACTIVITIES NEAR THE SENSITIVE FEATURE MUST BE SUSPENDED IMMEDIATELY. THE APPROPRIATE TCEQ REGIONAL OFFICE MUST BE IMMEDIATELY NOTIFIED OF ANY SENSITIVE FEATURES ENCOUNTERED DURING CONSTRUCTION. CONSTRUCTION ACTIVITIES MAY NOT BE RESUMED UNTIL THE TCEQ HAS REVIEWED AND APPROVED THE APPROPRIATE PROTECTIVE MEASURES IN ORDER TO PROTECT ANY SENSITIVE FEATURE AND THE EDWARDS AQUIFER FROM POTENTIALLY ADVERSE IMPACTS TO WATER QUALITY.
- NO TEMPORARY OR PERMANENT HAZARDOUS SUBSTANCE STORAGE TANK SHALL BE INSTALLED WITHIN 150 FEET OF A WATER SUPPLY SOURCE, DISTRIBUTION SYSTEM, WELL, OR SENSITIVE FEATURE.
- PRIOR TO BEGINNING ANY CONSTRUCTION ACTIVITY, ALL TEMPORARY EROSION AND SEDIMENTATION (E&S) CONTROL MEASURES MUST BE PROPERLY INSTALLED AND MAINTAINED IN ACCORDANCE WITH THE APPROVED PLANS AND MANUFACTURERS SPECIFICATIONS. IF INSPECTIONS INDICATE A CONTROL HAS BEEN USED INAPPROPRIATELY, OR INCORRECTLY, THE APPLICANT MUST REPLACE OR MODIFY THE CONTROL FOR SITE SITUATIONS. THESE CONTROLS MUST REMAIN IN PLACE UNTIL THE DISTURBED AREAS HAVE BEEN PERMANENTLY STABILIZED.
- ANY SEDIMENT THAT ESCAPES THE CONSTRUCTION SITE MUST BE COLLECTED AND PROPERLY DISPOSED OF BEFORE THE NEXT RAIN EVENT TO ENSURE IT IS NOT WASHED INTO SURFACE STREAMS, SENSITIVE FEATURES, ETC.
- SEDIMENT MUST BE REMOVED FROM THE SEDIMENT TRAPS OR SEDIMENTATION BASINS NOT LATER THAN WHEN IT OCCUPIES 50% OF THE BASIN'S DESIGN CAPACITY.
- LITTER, CONSTRUCTION DEBRIS, AND CONSTRUCTION CHEMICALS EXPOSED TO STORMWATER SHALL BE PREVENTED FROM BEING DISCHARGED OFFSITE.
- ALL SPOILS (EXCAVATED MATERIAL) GENERATED FROM THE PROJECT SITE MUST BE STORED ON-SITE WITH PROPER E&S CONTROLS. FOR STORAGE OR DISPOSAL OF SPOILS AT ANOTHER SITE ON THE EDWARDS AQUIFER RECHARGE ZONE, THE OWNER OF THE SITE MUST RECEIVE APPROVAL OF A WATER POLLUTION ABATEMENT PLAN FOR THE PLACEMENT OF SPOILS AT THE OTHER SITE.
- IF PORTIONS OF THE SITE WILL HAVE A TEMPORARY OR PERMANENT CEASE IN CONSTRUCTION ACTIVITY LASTING LONGER THAN 14 DAYS, SOIL STABILIZATION IN THOSE AREAS SHALL BE INITIATED AS SOON AS POSSIBLE PRIOR TO THE 14TH DAY OF INACTIVITY. IF ACTIVITY WILL RESUME PRIOR TO THE 21ST DAY, STABILIZATION MEASURES ARE NOT REQUIRED. IF DROUGHT CONDITIONS OR INCLEMENT WEATHER PREVENT ACTION BY THE 14TH DAY, STABILIZATION MEASURES SHALL BE INITIATED AS SOON AS POSSIBLE.
- THE FOLLOWING RECORDS SHALL BE MAINTAINED AND MADE AVAILABLE TO THE TCEQ UPON REQUEST:
  - THE DATES WHEN MAJOR GRADING ACTIVITIES OCCUR;
  - THE DATES WHEN CONSTRUCTION ACTIVITIES TEMPORARILY OR PERMANENTLY CEASE ON A PORTION OF THE SITE; AND
  - THE DATES WHEN STABILIZATION MEASURES ARE INITIATED.
- THE HOLDER OF ANY APPROVED EDWARDS AQUIFER PROTECTION PLAN MUST NOTIFY THE APPROPRIATE REGIONAL OFFICE IN WRITING AND OBTAIN APPROVAL FROM THE EXECUTIVE DIRECTOR PRIOR TO INITIATING ANY OF THE FOLLOWING:
  - ANY PHYSICAL OR OPERATIONAL MODIFICATION OF ANY WATER POLLUTION ABATEMENT STRUCTURE(S), INCLUDING BUT NOT LIMITED TO PONDS, DAMS, BERMS, SEWAGE TREATMENT PLANTS, AND DIVERSIONARY STRUCTURES;
  - ANY CHANGE IN THE NATURE OR CHARACTER OF THE REGULATED ACTIVITY FROM THAT WHICH WAS ORIGINALLY APPROVED OR A CHANGE WHICH WOULD SIGNIFICANTLY IMPACT THE ABILITY OF THE PLAN TO PREVENT POLLUTION OF THE EDWARDS AQUIFER;
  - ANY DEVELOPMENT OF LAND PREVIOUSLY IDENTIFIED AS UNDEVELOPED IN THE ORIGINAL WATER POLLUTION ABATEMENT PLAN.

SAN ANTONIO REGIONAL OFFICE  
14250 JUDSON ROAD  
SAN ANTONIO, TEXAS 78233-4480  
PHONE (210) 490-3098  
FAX (210) 845-4329

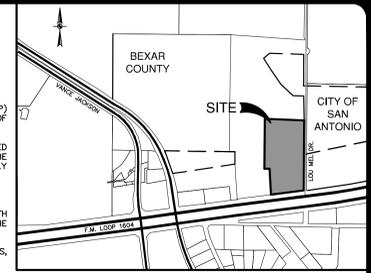

LEGAL DESCRIPTION: LOT 4, BLOCK 1, CB 4776 (PLAT 4 160338)  
ADDRESS: 4949 N LOOP 1604 W SAN ANTONIO, TEXAS 78249

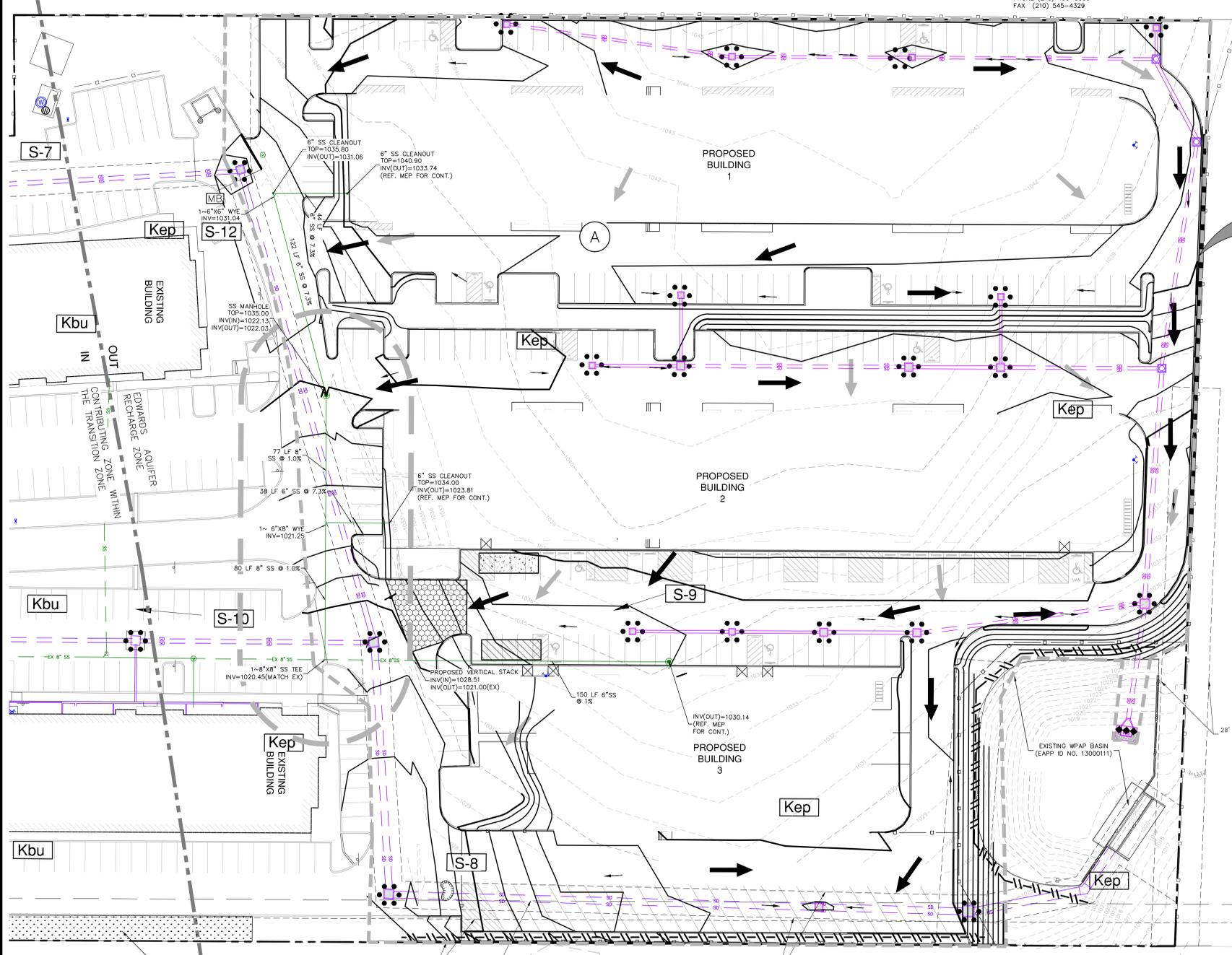
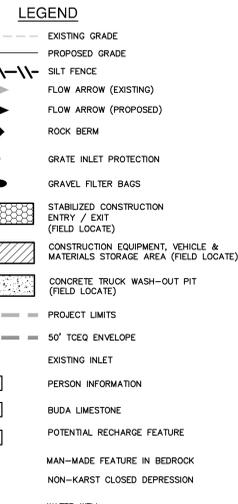
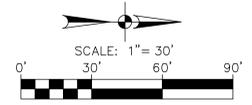

GENERAL NOTES

- DO NOT DISTURB VEGETATED AREAS (TREES, GRASS, WEEDS, BRUSH, ETC.) ANY MORE THAN NECESSARY FOR CONSTRUCTION.
- CONSTRUCTION ENTRANCE/EXIT LOCATION, CONCRETE WASH-OUT PIT, AND CONSTRUCTION EQUIPMENT AND MATERIAL STORAGE YARD TO BE DETERMINED IN THE FIELD.
- STORM WATER POLLUTION PREVENTION CONTROLS MAY NEED TO BE MODIFIED IN THE FIELD TO ACCOMPLISH THE DESIRED EFFECT. ALL MODIFICATIONS ARE TO BE NOTED ON THIS EXHIBIT AND SIGNED AND DATED BY THE RESPONSIBLE PARTY.
- RESTRICT ENTRY/EXIT TO THE PROJECT SITE TO DESIGNATED LOCATIONS BY USE OF ADEQUATE FENCING, IF NECESSARY.
- ALL STORM WATER POLLUTION PREVENTION CONTROLS ARE TO BE MAINTAINED AND IN WORKING CONDITION AT ALL TIMES.
- FOR A COMPLETE LISTING OF TEMPORARY STORM WATER POLLUTION PREVENTION CONTROLS REFER TO THE TPDES STORM WATER POLLUTION PREVENTION PLAN.
- STORM WATER POLLUTION PREVENTION STRUCTURES SHOULD BE CONSTRUCTED WITHIN THE SITE BOUNDARIES. SOME OF THESE FEATURES MAY BE SHOWN OUTSIDE THE SITE BOUNDARIES ON THIS PLAN FOR VISUAL CLARITY.
- AS SOON AS PRACTICAL, ALL DISTURBED SOIL THAT WILL NOT BE COVERED BY IMPERVIOUS COVER SUCH AS PARKWAY AREAS, EASEMENT AREAS, EMBANKMENT SLOPES, ETC. WILL BE STABILIZED PER APPLICABLE PROJECT SPECIFICATIONS.
- BEST MANAGEMENT PRACTICES MAY BE INSTALLED IN STAGES TO CONCORD WITH THE DISTURBANCE OF UPGRADENT AREAS.
- BEST MANAGEMENT PRACTICES MAY BE REMOVED IN STAGES ONCE THE WATERSHED FOR THAT PORTION CONTROLLED BY THE BEST MANAGEMENT PRACTICES HAS BEEN STABILIZED IN ACCORDANCE WITH TPDES REQUIREMENTS.
- UPON COMPLETION OF THE PROJECT, INCLUDING SITE STABILIZATION, AND BEFORE FINAL PAYMENT IS ISSUED, CONTRACTOR SHALL REMOVE ALL SEDIMENT AND EROSION CONTROL MEASURES, PAYING SPECIAL ATTENTION TO ROCK BERMS IN DRAINAGE FEATURES.
- WHERE VEGETATED FILTER STRIPS ARE INDICATED, CONTRACTOR SHALL VERIFY THAT SUFFICIENT VEGETATION EXISTS, OTHERWISE CONTRACTOR SHALL PLACE SILT FENCING IN LIEU OF VEGETATED FILTER STRIP.
- SHADED AREA DENOTES LIMITS OF DISTURBED AREAS. OTHER AREAS WITHIN THE PROJECT LIMITS, WITH THE EXCEPTION OF A CONSTRUCTION EQUIPMENT AND MATERIAL STORAGE YARD, ARE NOT A PART OF THIS TPDES STORM WATER POLLUTION PREVENTION PLAN (SWP3) AND WILL NOT BE DISTURBED BY CIVIL CONSTRUCTION ACTIVITIES. HOUSE CONSTRUCTION ACTIVITIES WILL REQUIRE A SEPARATE STORM WATER POLLUTION PREVENTION PLAN.
- PRIOR TO BEGINNING CONSTRUCTION, CONTRACTOR SHALL COORDINATE PLACEMENT OF TEMPORARY BEST MANAGEMENT PRACTICES WITHIN TxDOT RIGHT-OF-WAY WITH TxDOT.
- CPS ENERGY MAY FUNCTION AS A SECONDARY OPERATOR ON THIS PROJECT AND MAY BE INSTALLING ELECTRIC UTILITIES FOR ON-SITE CONSTRUCTION AND OFF-SITE FEED TO THE PROJECT.

TEMPORARY BMP MODIFICATIONS		
DATE	SIGNATURE	DESCRIPTION

THE ENGINEERING SEAL HAS BEEN AFFIXED TO THIS SHEET ONLY FOR THE PURPOSE OF DEMONSTRATING COMPLIANCE WITH THE POLLUTION ABATEMENT SIZING AND TREATMENT REQUIREMENTS OF THE TEXAS COMMISSION ON ENVIRONMENTAL QUALITY'S EDWARDS AQUIFER TECHNICAL GUIDANCE MANUAL.

THIS SHEET HAS BEEN PREPARED FOR PURPOSES OF POLLUTION ABATEMENT ONLY. ALL OTHER CIVIL ENGINEERING RELATED INFORMATION SHOULD BE ACQUIRED FROM THE APPROPRIATE SHEET IN THE CIVIL IMPROVEMENT PLANS.

EXHIBIT 1

NO.	REVISION	DATE



**PAPE-DAWSON ENGINEERS**  
2000 HW LOOP 410 | SAN ANTONIO, TX 78233 | 210.375.8000  
TEXAS ENGINEERING FIRM #471 | TEXAS SURVEYING FIRM #008890

**TERALTA PHASE II**  
SAN ANTONIO, TEXAS  
WATER POLLUTION ABATEMENT PLAN MODIFICATION  
TEMPORARY WATER POLLUTION ABATEMENT PLAN

PLAT NO. 160338  
JOB NO. 8771-09  
DATE FEBRUARY 2024  
DESIGNER RH  
CHECKED EX DRAWN RH  
SHEET C8.00

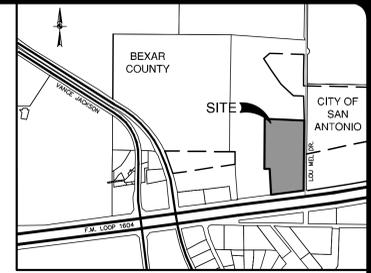

**LEGAL DESCRIPTION**  
LOT 4, BLOCK 1, CB 1778  
(PLAT # 160338)

**ADDRESS:**  
4949 N LOOP 1604 W  
SAN ANTONIO, TEXAS 78249

DATE	
NO. REVISION	
DATE	
NO. REVISION	

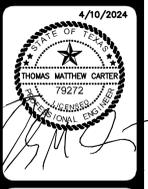

**PAPE-DAWSON ENGINEERS**

2008 HW LOOP 410 S SAN ANTONIO, TX 78233 | 210.575.8080  
TEXAS ENGINEERING FIRM #1771 | TEXAS SURVEYING FIRM #008890

**TERALTA PHASE II**  
SAN ANTONIO, TEXAS

**TEMPORARY WATER POLLUTION ABATEMENT PLAN**  
TYPICAL DETAILS

**EXHIBIT 3**

PLAT NO.	160338
JOB NO.	8771-09
DATE	FEBRUARY 2024
DESIGNER	RH
CHECKED	EX_DRAWN_RH
SHEET	C8.01

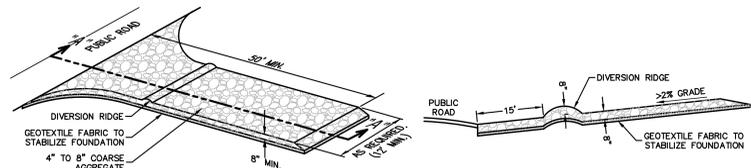

**SECTION "A-A" OF A CONSTRUCTION ENTRANCE/EXIT**

**MATERIALS**

1. THE AGGREGATE SHOULD CONSIST OF 4-INCH TO 8-INCH WASHED STONE OVER A STABLE FOUNDATION AS SPECIFIED IN THE PLAN.
2. THE AGGREGATE SHOULD BE PLACED WITH A MINIMUM THICKNESS OF 8-INCHES.
3. THE GEOTEXTILE FABRIC SHOULD BE DESIGNED SPECIFICALLY FOR USE AS A SOIL FILTRATION MEDIA WITH AN APPROXIMATE WEIGHT OF 6 OZ/YD<sup>2</sup>, A MULLEN BURST RATING OF 140 LB/IN<sup>2</sup>, AND AN EQUIVALENT OPENING SIZE GREATER THAN A NUMBER 50 SIEVE.
4. IF A WASHING FACILITY IS REQUIRED, A LEVEL AREA WITH A MINIMUM OF 4-INCH DIAMETER WASHED STONE OR COMMERCIAL ROCK SHOULD BE INCLUDED IN THE PLANS. DIVERT WASTEWATER TO A SEDIMENT TRAP OR BASIN.

**INSTALLATION**

1. "A" CURVES ON PUBLIC ROADS AND STEEP SLOPES. REMOVE VEGETATION AND OTHER OBJECTIONABLE MATERIAL FROM THE FOUNDATION AREA. GRADE CROWN FOUNDATION FOR POSITIVE DRAINAGE.
2. THE MINIMUM WIDTH OF THE ENTRANCE/EXIT SHOULD BE 12 FEET OR THE FULL WIDTH OF EXIST ROADWAY, WHICHEVER IS GREATER.
3. THE CONSTRUCTION ENTRANCE SHOULD BE AT LEAST 50 FEET LONG.
4. IF THE SLOPE TOWARD THE ROAD EXCEEDS 2%, CONSTRUCT A RIDGE, 6-INCHES TO 8-INCHES HIGH WITH 3:1 (H:V) SIDE SLOPES, ACROSS THE FOUNDATION APPROXIMATELY 15 FEET FROM THE ENTRANCE TO DIVERT RUNOFF AWAY FROM THE PUBLIC ROAD.
5. PLACE GEOTEXTILE FABRIC AND GRADE FOUNDATION TO IMPROVE STABILITY, ESPECIALLY WHERE MET CONDITIONS ARE ANTICIPATED.
6. PLACE STONE TO DIMENSIONS AND GRADE SHOWN ON PLANS. LEAVE SURFACE SMOOTH AND SLOPE FOR DRAINAGE.
7. DIVERT ALL SURFACE RUNOFF AND DRAINAGE FROM THE STONE PAD TO A SEDIMENT TRAP OR BASIN.
8. INSTALL PIPE UNDER PAD AS NEEDED TO MAINTAIN PROPER PUBLIC ROAD DRAINAGE.

**COMMON TROUBLE POINTS**

1. INADEQUATE RUNOFF CONTROL—SEDIMENT WASHES ONTO PUBLIC ROAD.
2. STONE TOO SMALL OR GEOTEXTILE FABRIC ABSENT, RESULTS IN MUDDY CONDITION AS STONE IS PRESSED INTO SOIL.
3. PAD TOO SHORT FOR HEAVY CONSTRUCTION TRAFFIC—EXTEND PAD BEYOND THE MINIMUM 50-FOOT LENGTH AS NECESSARY.
4. PAD NOT FLARED SUFFICIENTLY AT ROAD SURFACE, RESULTS IN MUD BEING TRACKED ON TO ROAD AND POSSIBLE DAMAGE TO ROAD.
5. UNSTABLE FOUNDATION—USE GEOTEXTILE FABRIC UNDER PAD AND/OR IMPROVE FOUNDATION DRAINAGE.

**INSPECTION AND MAINTENANCE GUIDELINES**

1. THE ENTRANCE SHOULD BE MAINTAINED IN A CONDITION WHICH WILL PREVENT TRACKING OR FLOWING OF SEDIMENT ONTO PUBLIC RIGHTS-OF-WAY. THIS MAY REQUIRE PERIODIC TOP DRESSING WITH ADDITIONAL STONE AS CONDITIONS DEMAND AND REPAIR AND/OR CLEANOUT OF ANY MEASURES USED TO TRAP SEDIMENT.
2. ALL SEDIMENT SPILLED, DROPPED, WASHED OR TRACKED ONTO PUBLIC RIGHTS-OF-WAY SHOULD BE REMOVED IMMEDIATELY BY CONTRACTOR.
3. WHEN NECESSARY, WHEELS SHOULD BE CLEANED TO REMOVE SEDIMENT PRIOR TO ENTRANCE ONTO PUBLIC RIGHTS-OF-WAY.
4. WHEN WASHING IS REQUIRED, IT SHOULD BE DONE ON AN AREA STABILIZED WITH CRUSHED STONE THAT DRAINS INTO AN APPROVED SEDIMENT TRAP OR SEDIMENT BASIN.
5. ALL SEDIMENT SHOULD BE PREVENTED FROM ENTERING ANY STORM DRAIN, DITCH OR WATER COURSE BY USING APPROVED METHODS.

**STABILIZED CONSTRUCTION ENTRANCE/EXIT DETAIL**

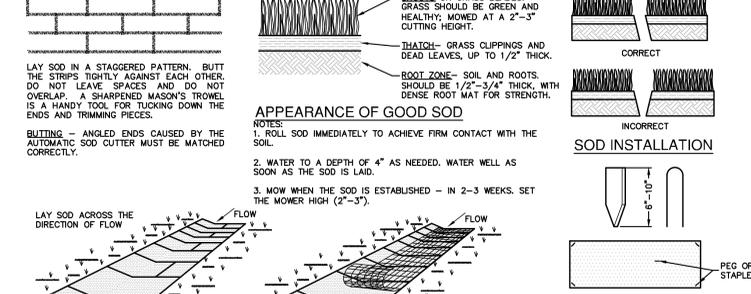

**APPEARANCE OF GOOD SOD**

**NOTES:**

1. ROLL SOD IMMEDIATELY TO ACHIEVE FIRM CONTACT WITH THE SOIL.
2. WATER TO A DEPTH OF 4" AS NEEDED. WATER WELL AS SOON AS THE SOD IS LAID.
3. MOW WHEN THE SOD IS ESTABLISHED—IN 2-3 WEEKS. SET THE MOWER HIGH (2"-3").

**GENERAL INSTALLATION (VA. DEPT. OF CONSERVATION, 1992)**

1. SOD SHOULD NOT BE CUT OR LAID IN EXCESSIVELY WET OR DRY WEATHER. SOD ALSO SHOULD NOT BE LAID ON SOIL SURFACES THAT ARE FROZEN.
2. DURING PERIODS OF HIGH TEMPERATURE, THE SOIL SHOULD BE LIGHTLY IRRIGATED IMMEDIATELY PRIOR TO LAYING THE SOD, TO COOL THE SOIL AND REDUCE ROOT BURNING AND DIEBACK.
3. THE FIRST ROW OF SOD SHOULD BE LAID IN A STRAIGHT LINE WITH SUBSEQUENT ROWS PLACED PARALLEL TO IT AND BUTTED TIGHTLY AGAINST EACH OTHER. LATERAL JOINTS SHOULD BE STAGGERED TO PROMOTE MORE UNIFORM GROWTH AND STRENGTH. CARE SHOULD BE EXERCISED TO ENSURE THAT SOD IS NOT STRETCHED OR OVERLAPPED AND THAT ALL JOINTS ARE BUTTED TIGHT IN ORDER TO PREVENT VOIDS WHICH WOULD CAUSE DRYING OF THE ROOTS (SEE FIGURE ABOVE).
4. ON SLOPES 3:1 OR GREATER, OR WHEREVER EROSION MAY BE A PROBLEM, SOD SHOULD BE LAID WITH STAGGERED JOINTS AND SECURED BY STAPLING OR OTHER APPROVED METHODS. SOD SHOULD BE INSTALLED WITH THE LENGTH PERPENDICULAR TO THE SLOPE (ON CONTOUR).
5. AS SODDING OF CLEARLY DEFINED AREAS IS COMPLETED, SOD SHOULD BE ROLLED OR TAMPED TO PROVIDE FIRM CONTACT BETWEEN ROOTS AND SOIL.
6. AFTER ROLLING, SOD SHOULD BE IRRIGATED TO A DEPTH SUFFICIENT THAT THE UNDERSIDE OF THE SOD PAD AND THE SOIL 4 INCHES BELOW THE SOD IS THOROUGHLY WET.
7. UNTIL SUCH TIME A GOOD ROOT SYSTEM BECOMES DEVELOPED, IN THE ABSENCE OF ADEQUATE RAINFALL, WATERING SHOULD BE PERFORMED AS OFTEN AS NECESSARY TO MAINTAIN MOST SOIL TO A DEPTH OF AT LEAST 4 INCHES.
8. THE FIRST MOWING SHOULD NOT BE ATTEMPTED UNTIL THE SOD IS FIRMLY ROOTED, USUALLY 2-3 WEEKS. NOT MORE THAN ONE THIRD OF THE GRASS LEAF SHOULD BE REMOVED AT ANY ONE CUTTING.

**INSPECTION AND MAINTENANCE GUIDELINES**

1. SOD SHOULD BE INSPECTED WEEKLY AND AFTER EACH RAIN EVENT TO LOCATE AND REPAIR ANY DAMAGE.
2. DAMAGE FROM STORMS OR NORMAL CONSTRUCTION ACTIVITIES SUCH AS TRUCKS OR DISTURBANCE OF SWALE STABILIZATION SHOULD BE REPAIRED AS SOON AS PRACTICAL.

**SOD INSTALLATION DETAIL**

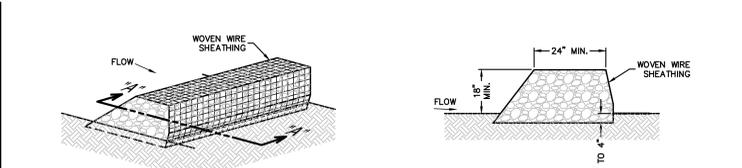

**ROCK BERM DETAIL**

**MATERIALS**

1. THE BERM STRUCTURE SHOULD BE SECURED WITH A WOVEN WIRE SHEATHING HAVING MAXIMUM OPENING OF 1 INCH AND A MINIMUM WIRE DIAMETER OF 20 GAUGE GALVANIZED AND SHOULD BE SECURED WITH SHOAT RINGS.
2. CLEAN, OPEN GRADED 3-INCH TO 5-INCH DIAMETER ROCK SHOULD BE USED, EXCEPT IN AREAS WHERE HIGH VELOCITIES OR LARGE VOLUMES OF FLOW ARE EXPECTED, WHERE 5-INCH TO 8-INCH DIAMETER ROCKS MAY BE USED.

**INSTALLATION**

1. LAY OUT THE WOVEN WIRE SHEATHING PERPENDICULAR TO THE FLOW LINE. THE SHEATHING SHOULD BE 20 GAUGE WOVEN WIRE MESH WITH 1 INCH OPENINGS.
2. BERM SHOULD HAVE A TOP WIDTH OF 2 FEET MINIMUM WITH SIDE SLOPES BEING 2:1 (H:V) OR FLATTER.
3. PLACE THE ROCK ALONG THE SHEATHING AS SHOWN IN THE DIAGRAM TO A HEIGHT NOT LESS THAN 18".
4. WRAP THE WIRE SHEATHING AROUND THE ROCK AND SECURE WITH THE WIRE SO THAT THE ENDS OF THE SHEATHING OVERLAP AT LEAST 2 INCHES, AND THE BERM RETAINS ITS SHAPE WHEN WALKED UPON.
5. BERM SHOULD BE BUILT ALONG THE CONTOUR AT ZERO PERCENT GRADE OR AS NEAR AS POSSIBLE.
6. THE ENDS OF THE BERM SHOULD BE TIED INTO EXISTING UPSLOPE GRADE AND THE BERM SHOULD BE BURIED IN A TRENCH APPROXIMATELY 3 TO 4 INCHES DEEP TO PREVENT FAILURE OF THE CONTOUR.

**COMMON TROUBLE POINTS**

1. INSUFFICIENT BERM HEIGHT OR LENGTH (RUNOFF QUICKLY ESCAPES OVER THE TOP OR AROUND THE SIDES OF BERM).
2. BERM NOT INSTALLED PERPENDICULAR TO FLOW LINE (RUNOFF ESCAPING AROUND ONE SIDE).

**INSPECTION AND MAINTENANCE GUIDELINES**

1. INSPECTION SHOULD BE MADE WEEKLY AND AFTER EACH RAINFALL BY THE RESPONSIBLE PARTY. FOR INSTALLATIONS IN STREAMBEDS, ADDITIONAL DAILY INSPECTIONS SHOULD BE MADE.
2. REMOVE SEDIMENT AND OTHER DEBRIS WHEN BUILDUP REACHES 6 INCHES AND DISPOSE OF THE ACCUMULATED SILT IN AN APPROVED MANNER THAT WILL NOT CAUSE ANY ADDITIONAL SILTATION.
3. REPAIR ANY LOOSE WIRE SHEATHING.
4. THE BERM SHOULD BE RESHAPED AS NEEDED DURING INSPECTION.
5. THE BERM SHOULD BE REPLACED WHEN THE STRUCTURE CEASES TO FUNCTION AS INTENDED DUE TO SILT ACCUMULATION AMONG THE ROCKS, WASHOUT, CONSTRUCTION TRAFFIC DAMAGE, ETC.
6. THE ROCK BERM SHOULD BE LEFT IN PLACE UNTIL ALL UPSTREAM AREAS ARE STABILIZED AND ACCUMULATED SILT REMOVED.

**ROCK BERM DETAIL**

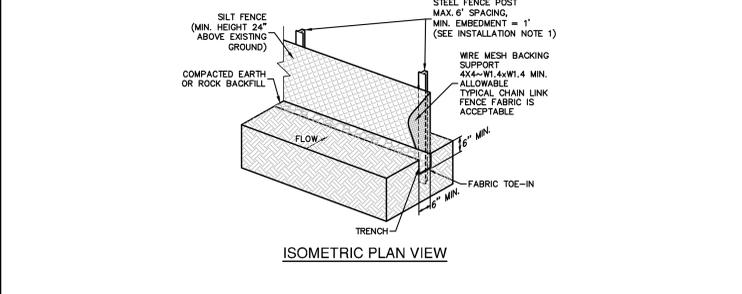

**SILT FENCE DETAIL**

**MATERIALS**

1. SILT FENCE MATERIAL SHOULD BE POLYPROPYLENE, POLYETHYLENE OR POLYAMIDE WOVEN OR NONWOVEN FABRIC. THE FABRIC SHOULD BE 36 INCHES, WITH A MINIMUM UNIT WEIGHT OF 4.5 OZ/YD, MULLEN BURST STRENGTH EXCEEDING 190 LB/IN<sup>2</sup>, ULTRAVIOLET STABILITY EXCEEDING 70% AND MINIMUM APPARENT OPENING SIZE OF U.S. SIEVE NUMBER 30.
2. FENCE POSTS SHOULD BE MADE OF HOT ROLLED STEEL, AT LEAST 4 FEET LONG WITH 1/2" OR 3/4" BAR CROSS SECTION, SURFACE PAINTED OR GALVANIZED. MINIMUM WEIGHT 1.25 LB/FT, AND BRIDWELL HARDNESS EXCEEDING 140.
3. WOVEN WIRE BACKING TO SUPPORT THE FABRIC SHOULD BE GALVANIZED 2" X 4" WELDED WIRE, 12 GAUGE MINIMUM.

**INSTALLATION**

1. STEEL POSTS, WHICH SUPPORT THE SILT FENCE, SHOULD BE INSTALLED ON A SLIGHT ANGLE TOWARD THE ANTICIPATED RUNOFF SOURCE. POSTS MUST BE EMBEDDED A MINIMUM OF 1-FOOT DEEP AND SPACED NOT MORE THAN 8 FEET ON CENTER, WHERE WATER CONCENTRATES, THE MAXIMUM SPACING SHOULD BE 6 FEET.
2. LAY OUT FENCING DOWN-SLOPE OF DISTURBED AREA, FOLLOWING THE CONTOUR AS CLOSELY AS POSSIBLE. THE FENCE SHOULD BE SITED SO THAT THE MAXIMUM DRAINAGE AREA IS 1/4 ACRE/100 FEET OF FENCE.

**INSPECTION AND MAINTENANCE GUIDELINES**

1. INSPECT ALL FENCING WEEKLY, AND AFTER RAINFALL.
2. REMOVE SEDIMENT WHEN BUILDUP REACHES 6 INCHES.
3. REPLACE TORN FABRIC OR INSTALL A SECOND LINE OF FENCING PARALLEL TO THE TORN SECTION.
4. REPLACE OR REPAIR SECTION CRUSHED OR COLLAPSED IN THE COURSE OF CONSTRUCTION ACTIVITY. IF A SECTION OF FENCE IS OBSTRUCTING VEHICULAR ACCESS, CONSIDER RELOCATING IT TO A SPOT WHERE IT WILL PROVIDE EQUAL PROTECTION, BUT WILL NOT OBSTRUCT VEHICLES. A TRIANGULAR FENCE PIKE MAY BE PREFERABLE TO A SILT FENCE AT COMMON VEHICULAR ACCESS POINTS.
5. WHEN CONSTRUCTION IS COMPLETE, THE SEDIMENT SHOULD BE DISPOSED OF IN A MANNER THAT WILL NOT CAUSE ADDITIONAL SILTATION AND THE PRIOR LOCATION OF THE SILT FENCE SHOULD BE REVEGETATED. THE FENCE ITSELF SHOULD BE DISPOSED OF IN AN APPROVED LANDFILL.

**SILT FENCE DETAIL**

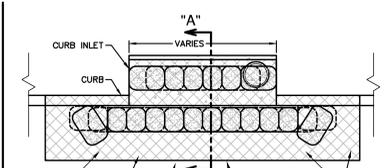

**BAGGED GRAVEL CURB INLET PROTECTION DETAIL**

**GENERAL NOTES**

1. CONTRACTOR TO INSTALL 2"x4"-W4-W1.4 WIRE MESH SUPPORTING FILTER FABRIC OVER THE INLET OPENING. FABRIC MUST BE SECURED TO WIRE BACKING WITH CLIPS OR WIRE TIES AT THIS LOCATION. SAND BAGS FILLED WITH WASHED PEA GRAVEL SHOULD BE PLACED ON TOP OF WIRE MESH ON TOP OF THE INLET AS SHOWN ON THIS DETAIL TO HOLD WIRE MESH IN PLACE. SANDBAGS FILLED WITH WASHED PEA GRAVEL SHOULD ALSO BE PLACED ALONG THE GUTTER AS SHOWN ON THIS DETAIL TO HOLD WIRE MESH IN PLACE. SAND BAGS TO BE STACKED TO FORM A CONTINUOUS BARRIER AROUND INLETS.
2. THE BAGS SHOULD BE TIGHTLY ABUTTED AGAINST EACH OTHER TO PREVENT RUNOFF FROM FLOWING BETWEEN THE BAGS.

**INSPECTION AND MAINTENANCE GUIDELINES**

1. INSPECTION SHOULD BE MADE WEEKLY AND AFTER EACH RAINFALL. REPAIR OR REPLACEMENT SHOULD BE MADE PROMPTLY AS NEEDED BY THE CONTRACTOR.
2. REMOVE SEDIMENT WHEN BUILDUP REACHES A DEPTH OF 3 INCHES. REMOVED SEDIMENT SHOULD BE DEPOSITED IN A SUITABLE AREA AND IN SUCH A MANNER THAT IT WILL NOT ERODE.
3. CHECK PLACEMENT OF DEVICE TO PREVENT GAPS BETWEEN DEVICE AND CURB.
4. INSPECT FILTER FABRIC AND PATCH OR REPLACE IF TORN OR MISSING.
5. STRUCTURES SHOULD BE REMOVED AND THE AREA STABILIZED ONLY AFTER THE REMAINING DRAINAGE AREA HAS BEEN PROPERLY STABILIZED.

**BAGGED GRAVEL CURB INLET PROTECTION DETAIL**

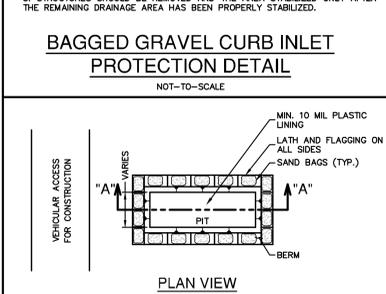

**BAGGED GRAVEL GRATE INLET PROTECTION DETAIL**

**GENERAL NOTES**

1. DETAIL ABOVE ILLUSTRATES MINIMUM DIMENSIONS. PIT CAN BE INCREASED IN SIZE DEPENDING ON EXPECTED FREQUENCY OF USE.
2. WASHOUT PIT SHALL BE LOCATED IN AN AREA EASILY ACCESSIBLE TO CONSTRUCTION TRAFFIC.
3. WASHOUT PIT SHALL NOT BE LOCATED IN AREAS SUBJECT TO INUNDATION FROM STORM WATER RUNOFF.
4. LOCATE WASHOUT AREA AT LEAST 50 FEET FROM SENSITIVE FEATURES, STORM DRAINS, OPEN DITCHES OR WATER BODIES.
5. TEMPORARY CONCRETE WASHOUT FACILITY SHOULD BE CONSTRUCTED WITH REMOVAL OF THE TEMPORARY CONCRETE VOLUMES TO CONTAIN ALL LIQUID AND CONCRETE WASTE GENERATED BY WASHOUT OPERATIONS.

**MATERIALS**

1. PLASTIC LINING MATERIAL SHOULD BE A MINIMUM OF 10 MIL IN POLYETHYLENE SHEETING AND SHOULD BE FREE OF HOLES, TEARS, OR OTHER DEFECTS THAT COMPROMISE THE IMPERMEABILITY OF THE MATERIAL.

**MAINTENANCE**

1. WHEN TEMPORARY CONCRETE WASHOUT FACILITIES ARE NO LONGER REQUIRED FOR THE WORK, THE HARDENED CONCRETE SHOULD BE REMOVED AND DISPOSED OF.
2. MATERIALS USED TO CONSTRUCT TEMPORARY CONCRETE WASHOUT FACILITIES SHOULD BE REMOVED FROM THE SITE OF THE WORK AND DISPOSED OF.
3. HOLES, DEPRESSIONS OR OTHER GROUND DISTURBANCES CAUSED BY THE REMOVAL OF THE TEMPORARY CONCRETE WASHOUT FACILITIES SHOULD BE BACKFILLED AND REPAIRED.

**CONCRETE TRUCK WASHOUT PIT DETAIL**

**CONSTRUCTION STAGING AREA**

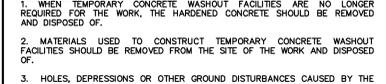

**CONSTRUCTION STAGING AREA**

THE ENGINEERING SEAL HAS BEEN AFFIXED TO THIS SHEET ONLY FOR THE PURPOSE OF DEMONSTRATING COMPLIANCE WITH THE TRODS-STORM WATER POLLUTION PREVENTION PLAN (SWP3) REGULATIONS.

**CONCRETE TRUCK WASHOUT PIT DETAIL**

**CONSTRUCTION STAGING AREA**

**CONCRETE TRUCK WASHOUT PIT DETAIL**

**CONSTRUCTION STAGING AREA**

TREATMENT SUMMARY

Watershed	Total Watershed Area (ac.)	Existing Impervious Cover (ac.)	Proposed Impervious Cover (ac.)	PBMP	Required TSS Removal Annually (lbs)	TSS Removed Annually (lbs)
A	11.11	0.83	8.01	Existing Water Quality Basin "A" (EAPP ID No 13000111)	5,859	5,940
OFFSITE	6.26	0.00	0.00	Existing Water Quality Basin "A" (EAPP ID No 13000111)	0	0
UNCAPTURED AREA B	0.12	0.00	0.10	Overtreatment Water Quality Basin "A"	82	N/A
C	0.68	0.00	0.47	Existing 15' Engineered VFS (EAPP ID No. 13000111)	384	384
<b>TOTAL</b>	<b>18.17</b>	<b>0.83</b>	<b>8.58</b>	---	<b>6,324</b>	<b>6,324</b>

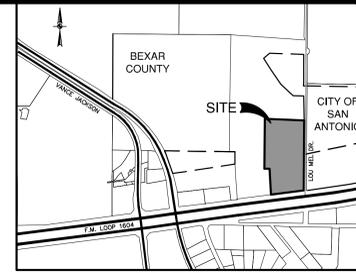

**LOCATION MAP**  
NOT-TO-SCALE  
LEGAL DESCRIPTION: LOT 4, BLOCK 1, CB 4776 (PLAT # 160338)  
ADDRESS: 4949 N LOOP 1604 W SAN ANTONIO, TEXAS 78249

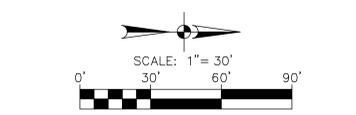

- LEGEND**
- 976- - - - - EXISTING GRADE
  - 970- - - - - PROPOSED GRADE
  - FLOW ARROW (EXISTING)
  - FLOW ARROW (PROPOSED)
  - - - - - PROJECT LIMITS
  - - - - - 50' TCEQ ENVELOPE
  - EXISTING INLET
  - PERSON INFORMATION
  - Kbu BUDA LIMESTONE
  - S-4 POTENTIAL RECHARGE FEATURE
  - MAN-MADE FEATURE IN BEDROCK
  - NON-KARST CLOSED DEPRESSION
  - WATER WELL

NO.	REVISION	DATE

4/10/2024

**PAPE-DAWSON ENGINEERS**  
2000 HW LOOP 410 | SAN ANTONIO, TX 78233 | 210.375.8000  
TEXAS ENGINEERING FIRM #071 | TEXAS SURVEYING FIRM #008890

**TERALTA PHASE II**  
SAN ANTONIO, TEXAS

WATER POLLUTION ABATEMENT PLAN MODIFICATION  
PERMANENT POLLUTION ABATEMENT PLAN

PLAT NO. 160338  
JOB NO. 8771-09  
DATE FEBRUARY 2024  
DESIGNER RH  
CHECKED EX DRAWN RH  
SHEET C8.02



**SUMMARY OF PERMANENT POLLUTION ABATEMENT MEASURES:**

- TEMPORARY BMP'S WILL BE MAINTAINED UNTIL THE SITE IMPROVEMENTS ARE COMPLETED AND THE SITE HAS BEEN STABILIZED, INCLUDING SUFFICIENT VEGETATION BEING ESTABLISHED.
- DURING CONSTRUCTION, TO THE EXTENT PRACTICAL, CONTRACTOR SHALL MINIMIZE THE AREA OF SOIL DISTURBANCE. AREAS OF DISTURBED SOIL SHALL BE REVEGETATED TO STABILIZE SOIL USING SOLID SOD IN A STAGGERED PATTERN. SEE DETAIL ON EXHIBIT 4 AND REFER TO SECTION 1.3.11 IN TCEQ'S TECHNICAL GUIDANCE MANUAL RG-348 (2005). SOD SHOULD BE USED IN CHANNELS AND ON SLOPES > 15%. THE CONTRACTOR MAY SUBSTITUTE THE USE OF SOD WITH THE PLACEMENT OF TOP SOIL AND A FRIABLE SEED BED WITH A PROTECTIVE MATTING OR HYDRAULIC MULCH ALONG WITH WATERING UNTIL VEGETATION IS ESTABLISHED. APPLICATIONS AND PRODUCTS SHALL BE THOSE APPROVED BY TxDOT AS OF FEBRUARY 2001 AND IN COMPLIANCE WITH THE TGM RG-348 (2005). SEED MIXTURE AND/OR GRASS TYPE TO BE DETERMINED BY OWNER AND SHOULD BE IN COMPLIANCE WITH TGM RG-348 (2005) GUIDELINES. IRRIGATION MAY BE REQUIRED IN ORDER TO ESTABLISH SUFFICIENT VEGETATION.
- FOR DISTURBED AREAS WHERE INSUFFICIENT SOIL EXISTS TO ESTABLISH VEGETATION, CONTRACTOR SHALL PLACE A MINIMUM OF 4" OF TOPSOIL PRIOR TO REVEGETATION.
- PERMANENT BMP'S FOR THIS SITE INCLUDE A SAND FILTER BASIN AND ONE (1) ENGINEERED VEGETATIVE FILTER STRIP. THESE PERMANENT BMP'S HAVE BEEN DESIGNED TO REMOVE AT LEAST 80% OF THE INCREASED TOTAL SUSPENDED SOLIDS (TSS) FOR THE 12.43 ACRES IN ACCORDANCE WITH THE TCEQ'S TECHNICAL GUIDANCE MANUAL (TGM) RG-348 (2005).
- TYPICAL SLOPES ON THIS PROJECT RANGE FROM APPROXIMATELY 1.0% TO 10.0%.
- SILT FENCING AND ROCK BERMS, WHERE APPROPRIATE, WILL BE MAINTAINED UNTIL THE ROADWAY, UTILITY, DRAINAGE IMPROVEMENTS, AND BUILDING CONSTRUCTION ARE COMPLETED.
- CONTRACTOR SHALL INSTALL AND ESTABLISH VEGETATION FOR SOIL STABILIZATION PRIOR TO SITE CLOSEOUT.
- ALL PERMANENT BMP'S MUST BE CERTIFIED BY A REGISTERED PROFESSIONAL ENGINEER.

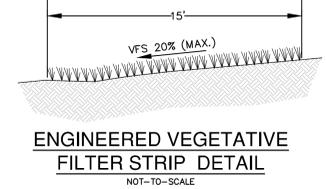

THE ENGINEERING SEAL HAS BEEN AFFIXED TO THIS SHEET ONLY FOR THE PURPOSE OF DEMONSTRATING COMPLIANCE WITH THE POLLUTION ABATEMENT SIZING AND TREATMENT REQUIREMENTS OF THE TEXAS COMMISSION ON ENVIRONMENTAL QUALITY'S EDWARDS AQUIFER TECHNICAL GUIDANCE MANUAL.

THIS SHEET HAS BEEN PREPARED FOR PURPOSES OF POLLUTION ABATEMENT ONLY. ALL OTHER CIVIL ENGINEERING RELATED INFORMATION SHOULD BE ACQUIRED FROM THE APPROPRIATE SHEET IN THE CIVIL IMPROVEMENT PLANS.

EXHIBIT 3

Date: February 14, 2024, 3:44 PM - User: ID: abraham  
File: V:\Team Center Reference\CARTER SEALING

THIS DOCUMENT HAS BEEN PRODUCED FROM MATERIAL THAT WAS STORED AND/OR TRANSMITTED ELECTRONICALLY AND MAY HAVE BEEN INADEQUATELY ALTERED. RELY ONLY ON FINAL HARD COPY MATERIALS BEARING THE CONSULTANT'S ORIGINAL SIGNATURE AND SEAL. IMAGES PROVIDED BY GOOGLE UNLESS OTHERWISE NOTED. Imagery © 2016 Google/Google Earth/Ordnance Survey, USA Form Service Agency.

