

**TASWA DISPOSAL AND RECYCLING FACILITY
GRAYSON COUNTY, TEXAS
TCEQ PERMIT NO. MSW 2290A**

PERMIT AMENDMENT APPLICATION

VOLUME 4 OF 4

Prepared for

TEXOMA AREA SOLID WASTE AUTHORITY, INC.

February 2025
Revised March 2025
Revised June 2025

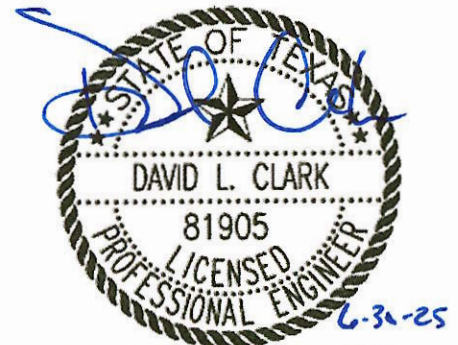

Biggs & Mathews Environmental, Inc.
Firm Registration No. F-256

Prepared by

BIGGS & MATHEWS ENVIRONMENTAL
1700 Robert Road, Suite 100 ♦ Mansfield, Texas 76063 ♦ 817-563-1144

TEXAS BOARD OF PROFESSIONAL ENGINEERS
FIRM REGISTRATION No. F-256

TEXAS BOARD OF PROFESSIONAL GEOSCIENTISTS
FIRM REGISTRATION No. 50222

**TASWA DISPOSAL AND RECYCLING FACILITY
GRAYSON COUNTY, TEXAS
TCEQ PERMIT NO. MSW 2290A**

PERMIT AMENDMENT APPLICATION

VOLUME 4 OF 4

CONTENTS

PART III FACILITY INVESTIGATION AND DESIGN

- Attachment G – Landfill Gas Management Plan
- Attachment H – Closure Plan
- Attachment I – Postclosure Plan
- Attachment J – Cost Estimates for Closure and Postclosure Care

PART IV SITE OPERATING PLAN

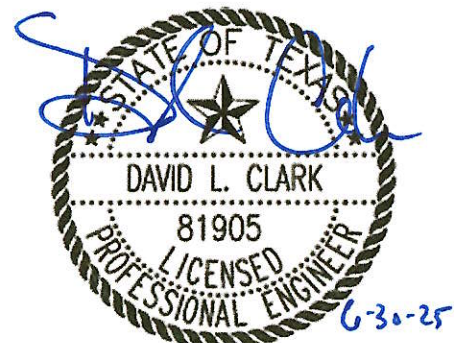

Biggs & Mathews Environmental, Inc.
Firm Registration No. F-256

**TASWA DISPOSAL AND RECYCLING FACILITY
GRAYSON COUNTY, TEXAS
TCEQ PERMIT NO. MSW 2290A**

PERMIT AMENDMENT APPLICATION

**PART III – FACILITY INVESTIGATION AND DESIGN
ATTACHMENT G
LANDFILL GAS MANAGEMENT PLAN**

Prepared for

TEXOMA AREA SOLID WASTE AUTHORITY

February 2025
Revised June 2025

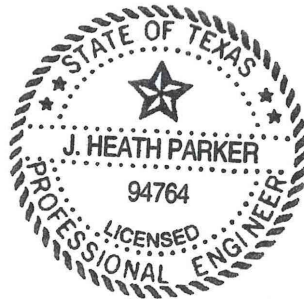

J. Heath Parker
06/30/2025

Prepared by

BIGGS & MATHEWS ENVIRONMENTAL
1700 Robert Road, Suite 100 ♦ Mansfield, Texas 76063 ♦ 817-563-1144

TEXAS BOARD OF PROFESSIONAL ENGINEERS AND LAND SURVEYORS
FIRM REGISTRATION No. F-256 AND No. 10194895

TEXAS BOARD OF PROFESSIONAL GEOSCIENTISTS
FIRM REGISTRATION No. 50222

CONTENTS

1	INTRODUCTION.....	1
2	SITE CHARACTERISTICS	3
3	MONITORING.....	5
4	ACTION PLAN.....	9
5	REMEDIATION PLAN.....	10
6	LFG CONTROL SYSTEM.....	11

APPENDIX G1

Landfill Gas Monitoring Probe Plan

APPENDIX G2

Reporting and Recording Forms

APPENDIX G3

Landfill Gas Monitoring Probe Boring/Completion Logs

APPENDIX G4

Landfill Gas Collection and Control System Plan



J. Heath Parker
06/30/2025

1 INTRODUCTION

30 TAC §§330.63(g), 330.371

1.1 Scope

This landfill gas (LFG) management plan has been developed for TASWA Disposal and Recycling Facility (TASWA DRF) as required by 30 TAC §330.63(g). This LFG management plan is consistent with the requirements set forth in §330.371 and provides a site-specific approach to implementing LFG monitoring. This plan describes the existing and proposed LFG monitoring network, the operation and monitoring of this network, notification procedures, and possible remediation activities, if required.

The TASWA DRF will comply with all applicable federal and state regulations.

1.2 Purpose

§330.371 requires landfills to implement a routine LFG monitoring program to verify that (1) the concentration of methane does not exceed 1.25 percent methane by volume in facility structures (excluding LFG collection and control system components), and (2) the concentration of methane does not exceed five percent methane by volume in monitoring points, probes, subsurface soils, or other matrices at the permit boundary.

The purpose of this LFG management plan is to provide guidance for management of LFG at the site. These guidelines cover the evaluation of methane concentrations at the permit boundary and in structures on the permitted site.

1.3 General

Consistent with §330.371(d), the executive director may establish alternative schedules for demonstrating compliance with methane monitoring as required by §330.371(b), and with action plan activities as required by §330.371(c).

Consistent with §330.371(e), the landfill gas monitoring and control program will continue for a period of 30 years after certification of final closure of the facility, or until Texoma Area Solid Waste Authority (TASWA) receives written authorization to reduce the program. Authorization to reduce gas monitoring and control shall be based on a demonstration by the owner or operator that there is no potential for gas migration beyond the permit boundary or into on-site structures. The demonstration will be supported by data collected and additional studies, as required.

Consistent with §330.371(f), gas monitoring and control systems will be revised as needed to maintain current and effective gas monitoring and control. Post closure land use of the facility will not interfere with the function of gas monitoring and control

systems. Any underground utility trenches that cross the permit boundary will be vented and monitored regularly, contingent on approval from the utility easement owner.

2 SITE CHARACTERISTICS

30 TAC §330.371

2.1 Introduction

Ten LFG monitoring probes have been installed outside the perimeter of the waste fill area, near the permit boundary, to detect potential LFG migration. The proposed LFG monitoring network consists of a total of twenty-one probes. The existing and proposed LFG monitoring probe locations are shown in Appendix G1.

The type and frequency of LFG monitoring for this site are based on the following factors:

2.2 Soil Conditions

The site geologic conditions are discussed in Attachment E.

2.3 Hydrogeologic Conditions

The hydrogeologic conditions are discussed in Attachment E.

2.4 Hydraulic Conditions

Hydraulic conditions are discussed in Attachment C1.

2.5 Facility Structures Within the Permit Boundary

There are 3 structures within the TASWA DRF permit boundary including a scalehouse, a maintenance building, and an office building. These structures are enclosed and have continuous methane monitors. All enclosed structures will be monitored for the presence of LFG as described in Section 3.2.1 of this attachment. Refer to Drawing G1.1 for the location of the structures.

2.6 Underground Utilities

There are no underground utility lines or easements that enter or exit the TASWA DRF permit boundary.

2.7 Offsite Structures

All known habitable structures located offsite within ¼ mile of the permit boundary are depicted on Drawing G1.3.

3 MONITORING

30 TAC §330.371

3.1 Perimeter Monitoring

3.1.1 Perimeter Monitoring Network

The current LFG monitoring probe network at the landfill consists of ten LFG monitoring probes located outside the perimeter of the waste fill area near the permit boundary. During future development of the site, nine probes, GMP-2 through GMP-7 and GMP-9 through GMP-11, will be relocated and eleven probes will be added, resulting in a total of twenty-one LFG monitoring probes for the proposed LFG monitoring network. Proposed locations of the LFG monitoring probes are shown on Drawing G1.1. Copies of the installation logs for the existing LFG monitoring probes are included in Appendix G3.

The landfill gas monitoring probes will be installed in phases as the waste footprint develops. GMP-1, GMP-2R, GMP-3R, GMP-4R, GMP-5R, GMP-6R, GMP-7R, GMP-9R, GMP-10R, GMP-11R, GMP-12, and GMP-13 will be installed within 120 days of final approval of the permit amendment. For the remainder of the proposed probes, prior to receiving waste in any new sector, all probes within 1,000 feet of that sector will be installed.

3.1.2 Landfill Gas Monitoring Probes

LFG monitoring probes have been installed along the perimeter of the existing waste fill area. Copies of the installation logs for the existing LFG monitoring probes are included in Appendix G3.

Future LFG monitoring probes will be installed in accordance with the detail shown on Drawing G1.2. Once installation is completed, boring logs and completion logs will be submitted to TCEQ and added to Appendix G3.

Each gas monitoring probe is designed to monitor the soil strata above the lowest planned future elevation of waste within 1,000 feet of the probe. The interprobe spacing for the gas monitoring probes will be a maximum of 1,000 feet. The as-built or design depths and elevations for each of the existing and proposed gas monitoring probes is shown on the table on Drawing G1.1.

3.1.3 Utility Vents

Currently there are no underground utility lines or easements that enter or exit the TASWA DRF permit boundary. Should a future underground utility line or easement be established across the permit boundary, utility vents will be installed in accordance with the detail shown on Drawing G1.2.

3.1.4 Monitoring Procedures

Monitoring will be conducted by a qualified landfill representative or a qualified consultant. To avoid artificially impacting the probe static pressure during the induction of the gas sample into the instrument, the static pressure will be measured and recorded prior to measuring gas composition.

During each monitoring event, the probes will be monitored for the following parameters:

- Methane concentration, as measured in percent by volume
- Oxygen concentration (optional), as measured in percent by volume
- Static pressure, as measured in inches of water column, gauge
- Depth to groundwater, as measured in feet

Monitoring for gas composition and gas pressure will be performed using a portable Landtec® GEM-2000, or equivalent instrument, capable of measuring the required parameters. The monitoring equipment will be calibrated and maintained in accordance with the manufacturer's recommended procedures. Manufacturer's maintenance and calibration requirements for the monitoring instruments will be maintained on site with the LFG monitoring records described in Section 3.3.

The monitoring device will have a suction sampling line equipped with a quick-disconnect fitting. This fitting will match up with a corresponding quick-disconnect fitting on the top of each probe to enable gas samples to be drawn directly into the monitoring instrument without diluting the sample. The indicator will give a direct reading of the methane concentration in one of two scales, percent of the lower explosive limit (LEL) or percent by volume.

After these parameters are measured, the probe of a liquid level indicator will be lowered into the LFG probe through an opening located at the top of the LFG probe to measure water level (if any) inside the LFG probe. If no water is present, the level indicator will be used to verify and report total depth of the probe to assure that the probe is not obstructed.

3.1.5 Maintenance Procedures

Each time LFG monitoring is conducted, the sampler will inspect the integrity of the LFG monitoring probes. The sampler will record pertinent information on the Quarterly Landfill Gas Monitoring Report (see Appendix G2) or similar forms. The Quarterly Landfill Gas Monitoring Report will be kept in the site operating record. The sampler will perform the following at each monitoring event:

- Verify that the LFG monitoring probe is clearly labeled on the outer casing or lid.
- Verify that the protective casing is intact and is not bent or excessively corroded.

- Verify that the concrete pad is intact (no evidence of cracking or heaving).
- Verify that the padlock is functional.
- Verify that the inner casing is intact.

If damage to the LFG monitoring probe is observed, it will be reported to the site manager. If it is not possible to repair the LFG monitoring probe and the damage can potentially affect the accuracy of future monitoring results, the LFG monitoring probe will be decommissioned and replaced with a new LFG monitoring probe in accordance with Sections 3.1.2 and 3.4 of this attachment.

3.2 Facility Structures Monitoring

3.2.1 Monitoring Procedures

On-site buildings and structures designed for human occupation will be monitored with a continuous LFG monitor/alarm that will provide an audible alarm if methane concentrations exceed 1.25 percent methane by volume.

If allowable methane concentration limits are exceeded within structures, the building will be immediately evacuated and ventilated by opening doors and windows. Notification consistent with procedures in Section 4.2 of this attachment will be implemented immediately.

3.2.2 Maintenance Procedures

Continuous LFG monitors/alarms will be calibrated and maintained in accordance with the manufacturer's recommendations. Continuous LFG monitors/alarms will be tested following the manufacturer's testing specifications.

3.3 Recordkeeping/Reporting

Field monitoring data records will be maintained for the methane monitoring and kept in the site operating record. Field data will be recorded on the Quarterly Landfill Gas Monitoring Report form (or similar form) as shown in Appendix G2.

3.4 Backup Plan for Monitoring Probes and Continuous Monitors

The following is a back-up plan to be used if any installed LFG monitoring probes or continuous monitoring devices become unusable or inoperative.

Stationary Perimeter Probes

1. Damaged or inoperative perimeter probes will be repaired within 30 days of the date of damage or replaced within 60 days from the TCEQ approval date of the permit modification requesting replacement.
2. Upon completion of the replacement probe, an installation report including boring logs and construction details will be submitted to the TCEQ.
3. Should a monitoring event occur prior to replacement of a damaged probe, a bar-hole will be placed next to the damaged probe and a portable gas monitor will be used until the probe is replaced.

Stationary Combustible Gas Monitor

1. Damaged or inoperative stationary combustible gas monitors will be repaired within 30 days of the date of damage or replaced within 60 days.
2. A portable gas indicator will be used until the damaged or inoperative stationary unit is replaced.

3.5 Monitoring Frequency

LFG monitoring points, probes, subsurface soils, or other matrices will be monitored quarterly, at a minimum. Facility structures will be monitored using continuous LFG monitors. The facility will monitor more frequently those locations where monitoring results indicate that LFG migration is occurring or is accumulating in structures.

The LFG monitoring program will continue for a period of 30 years after the final closure of the facility or until the owner or operator receives written authorization from the TCEQ to revise or discontinue the program.

4 ACTION PLAN

30 TAC §330.371

4.1 Initial Response Measures

As required under 30 TAC §330.371, this action plan has been prepared for the protection of human health in the event concentrations of methane exceed allowable limits either within on-site buildings or at the permit boundary of the site. The appropriate emergency response is different for each situation; therefore, this plan addresses buildings and permit boundaries separately.

4.1.1 Emergency Action

The initial action in the event methane is detected at levels above regulatory limits is to protect human health. The specific response depends on the circumstances of the situation.

Buildings/Structures. If the monitoring device in a facility building/structure is triggered, or if gas monitoring equipment indicates that the methane concentration has exceeded the regulatory limit, the building/structure is to be evacuated of all personnel immediately and the site manager will be notified. Personnel (except for authorized monitoring personnel) will not be allowed to re-enter the affected building/structure until additional measures are taken.

Permit Boundary. If methane levels above the regulatory limit are detected at the permit boundary in the LFG monitoring points, probes, subsurface soils, or other matrices, the site manager will be notified. The immediate emergency response measure will be for the site manager to determine if any nearby buildings or structures (including off-site) are at risk and if evacuation of the buildings or structures should be requested.

4.2 Notification Procedures

Once immediate actions have been completed to protect human health, notifications will be made immediately in accordance with §330.371. Notification will be made to the executive director of the TCEQ; the TCEQ Region 4 office; Grayson County Office of Emergency Management; and any owners of property within 1/4 mile of the reading.

The site manager will place in the site operating record documentation of the methane gas levels detected and a description of the steps taken to ensure protection of human health within seven days of detection in accordance with §330.371.

5 REMEDIATION PLAN

30 TAC §330.371

5.1 Remediation Plan

If methane levels above regulatory limits are encountered in the buildings/structures or in one or more LFG monitoring points, probes, subsurface soils, or other matrices, remediation actions will be implemented within 60 days. The first action will be an investigation of the cause of the methane levels. The investigation may include some or all of the following elements, depending on the circumstances:

- Bar-hole probe or hydropunch testing in the vicinity of the impacted monitoring probe
- Sampling and laboratory analysis of LFG monitoring probe samples to determine concentration of methane and trace compounds
- Additional LFG probe monitoring
- Installation of additional monitoring probes

Using accumulated data, an assessment will be made to determine an appropriate course of action to manage and control the migration of LFG. Such actions will vary with the specific incident. An incident-specific remediation plan, based on results of the investigation, will be submitted within 60 days of detection. Copies of the remediation plan will be placed in the site operating record and provided to the executive director of the TCEQ along with notification that the plan has been implemented. The executive director may establish an alternative schedule for demonstrating compliance.

6 LFG CONTROL SYSTEM

30 TAC §330.371

6.1 LFG Collection and Control System

As the site develops, extraction wells will be installed as needed to control landfill gas and meet regulatory requirements. The locations of the anticipated future vertical LFG extraction wells are shown on Drawing G4.1. The existing GCCS is shown on Drawing G4.2.

The LFG extraction wells will be constructed as shown on Drawing G4.3. Each extraction well will consist of a perforated pipe within a gravel backfill. The LFG extraction wells will be installed in phases as needed based on waste placement patterns. The exact number and location of extraction points, piping, and proposed future LFG facilities will be determined based on field conditions at the time of installation. Upon completion of each phase of the GCCS installation, as-built record drawings suitable for inclusion in this permit will be submitted to the TCEQ and a copy placed in the site operating record.

Blowers, flares, and piping will be installed as needed to provide the vacuum and capacity to handle the predicted maximum flow rate of LFG. In addition, LFG may also be sent to a Landfill Gas to Energy Facility. Each extraction well will be equipped with a control valve and monitoring port, as shown on Drawing G4.2. These control valves and monitoring ports, used in conjunction with controls on the blower, will allow the site to regulate vacuum and LFG levels at each individual extraction well. This will allow the site to make adjustments in order to effectively collect LFG.

The operation and maintenance of the proposed LFG system will be performed consistent with industry guidelines and practices. Wellhead and system monitoring will be performed on a routine basis to monitor overall system performance. As needed, system adjustments will be made to optimize the extraction of LFG from the landfill to control LFG migration, odors, and greenhouse gases. In addition, the system will be routinely visually inspected for any evidence of needed repairs or other maintenance. General maintenance procedures will include the following:

- Each wellhead will be monitored and adjusted as needed to control LFG while limiting oxygen intrusion into the landfill.
- Condensate sumps will be checked for proper operation.
- Blowers and flares will be inspected for proper operation.

The final GCCS will include isolation valves and a looped piping network to allow the system to be adjusted, maintained, and quickly repaired.

**APPENDIX G1
LANDFILL GAS MONITORING PROBE PLAN**

O:\TASWA\Drawings\ATT\G1.1 Gas Probe Plan.dwg Layout: G1.1 User: HParker

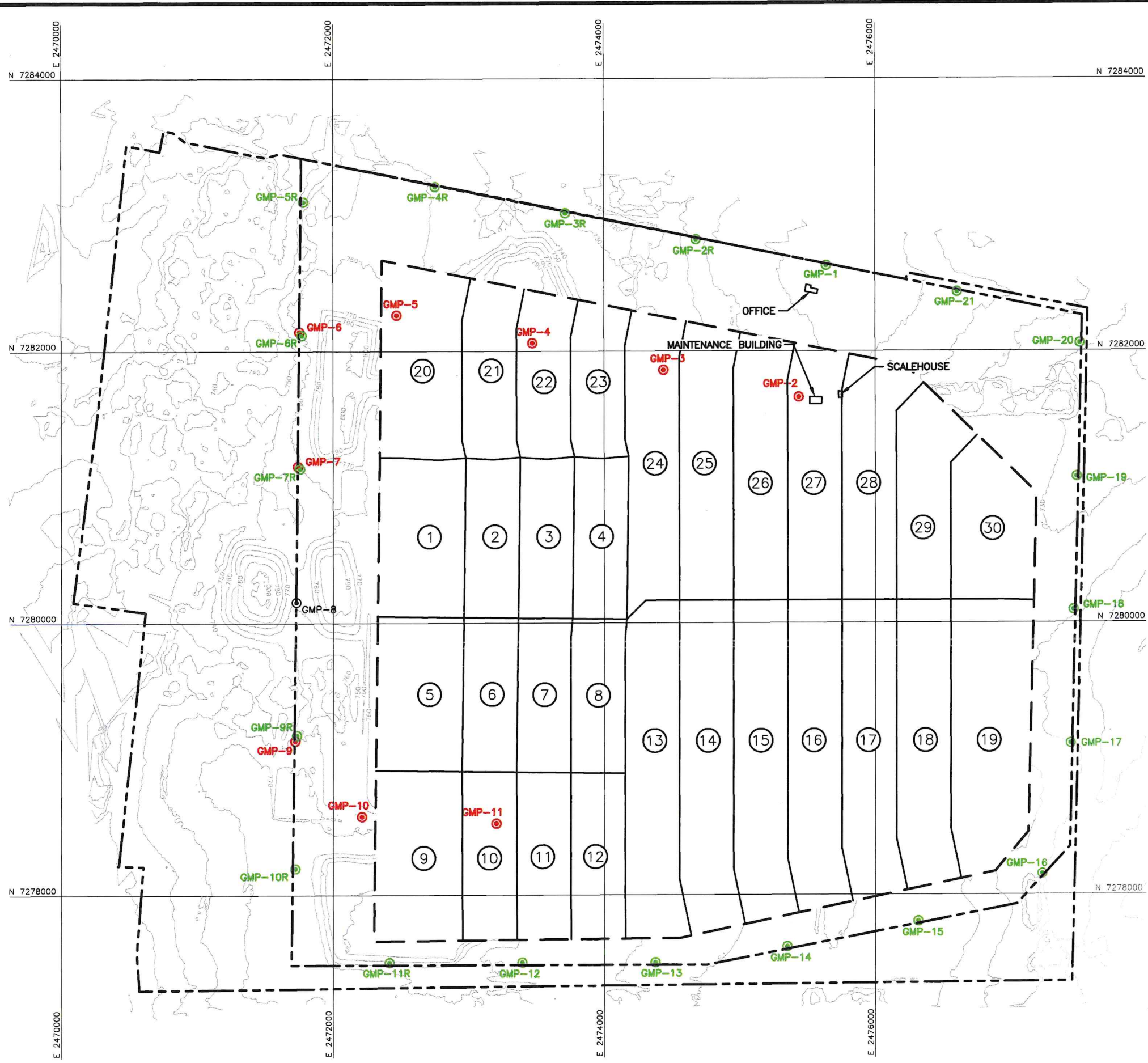

LEGEND

- PROPERTY BOUNDARY
- - - PROPOSED PERMIT BOUNDARY
- WASTE BOUNDARY
- N 7278000 STATE PLANE COORDINATES
- 750 EXISTING 10' GROUND CONTOUR
- ⑭ SECTOR NUMBER (DEVELOPMENT SEQUENCE)
- ⊙ GMP-6 EXISTING LANDFILL GAS MONITORING PROBE
- ⊙ GMP-1 PROPOSED LANDFILL GAS MONITORING PROBE
- ⊙ GMP-10 EXISTING LANDFILL GAS MONITORING PROBE (TO BE PLUGGED)



GAS PROBE DESIGN INFORMATION			
PROBE NAME	GROUND ELEVATION (FT-MSL)	BOTTOM ELEVATION (FT-MSL)	PROBE DEPTH (FT)
EXISTING GAS MONITORING PROBES			
GMP-2	746.5	723.5	23.0
GMP-3	735.0	720.0	15.0
GMP-4	749.5	729.5	20.0
GMP-5	759.0	739.0	20.0
GMP-6	756.0	715.0	41.0
GMP-7	755.5	714.5	41.0
GMP-8	759.5	714.5	45.0
GMP-9	756.0	716.0	40.0
GMP-10	766.7	702.7	64.0
GMP-11	768.2	702.2	66
PROPOSED GAS MONITORING PROBES			
GMP-1	755	672	83
GMP-2R	736	670	66
GMP-3R	732	668	64
GMP-4R	749	665	84
GMP-5R	737	712	25
GMP-6R	759	665	94
GMP-7R	760	675	85
GMP-9R	756	680	76
GMP-10R	776	668	108
GMP-11R	797	668	129
GMP-12	778	668	110
GMP-13	767	668	99
GMP-14	753	668	85
GMP-15	759	670	89
GMP-16	731	670	61
GMP-17	730	672	58
GMP-18	732	679	53
GMP-19	726	679	47
GMP-20	722	705	17
GMP-21	746	673	73

* HIGHLIGHTED WELLS ARE NOT YET INSTALLED.



J. Heath Parker
2/28/2025

- NOTES:**
- EXISTING GROUND CONTOURS PROVIDED BY BIGGS AND MATHEWS ENVIRONMENTAL FROM DRONE SURVEY FLOWN ON JUNE 1, 2022.

GAS MONITORING PROBE PLAN	
TEXOMA AREA SOLID WASTE AUTHORITY TASWA DRF PERMIT AMENDMENT	
BME	BIGGS & MATHEWS ENVIRONMENTAL 1700 ROBERT ROAD, STE. 100 MANSFIELD, TEXAS 76063 817-563-1144
TBPE FIRM NO. F-256	DRAWING
TBPG FIRM NO. 50222	G1.1

ISSUED FOR PERMITTING PURPOSES ONLY

O:\TASWA\Drawings\ATT G\G1.2 Probe Detail.dwg Layout: G1.2 User: HParker

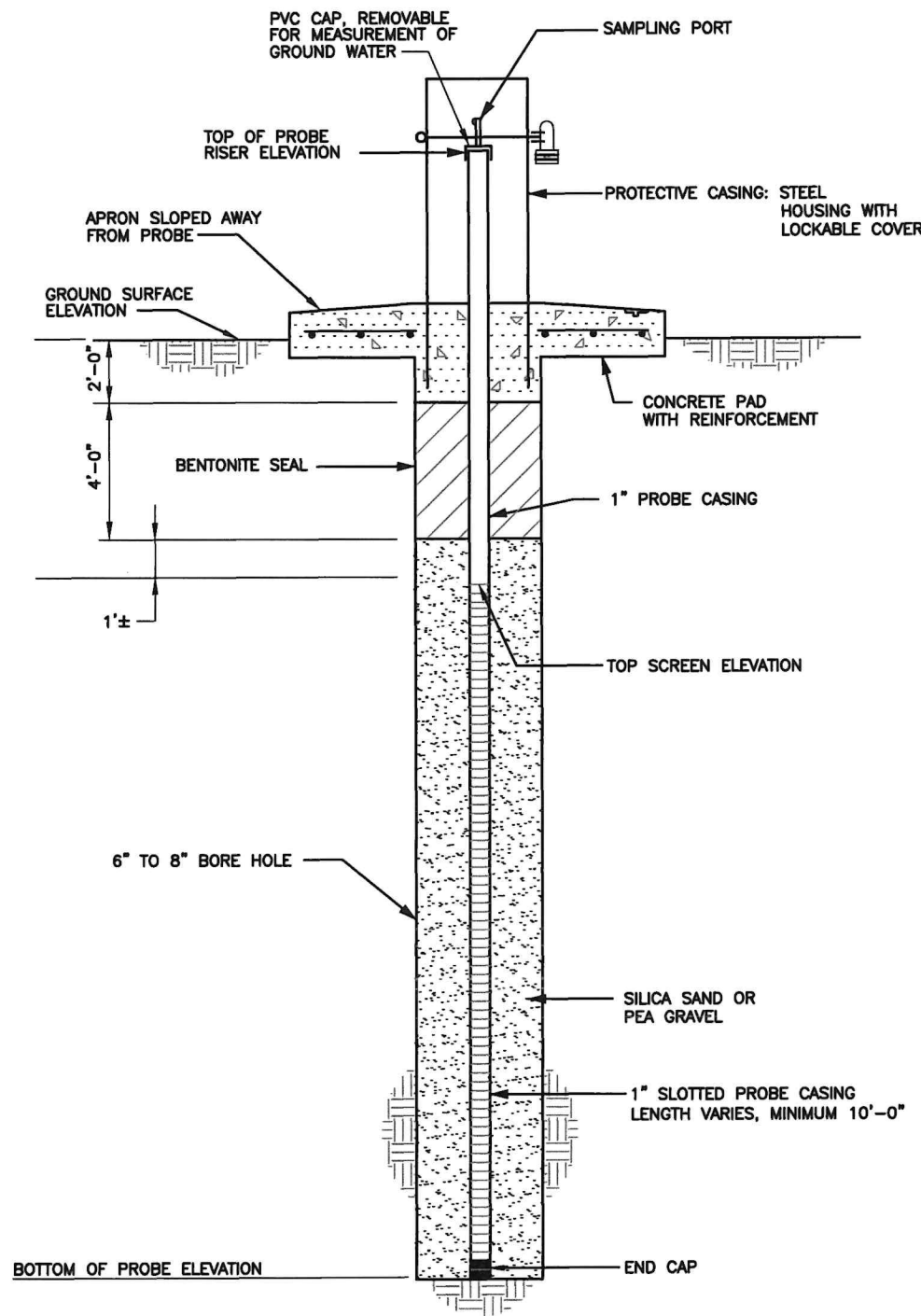

MONITORING PROBE DETAILS MP-1
NTS G1.2

NOTES

1. PROBES WILL BE INSTALLED TO MONITOR THE SOIL STRATA ABOVE THE LOWEST CURRENT OR PLANNED FUTURE ELEVATION OF WASTE WITHIN 1,000 FEET OF THE MONITORING PROBE.
2. ALL SIZES AND DIMENSIONS ARE APPROXIMATE.

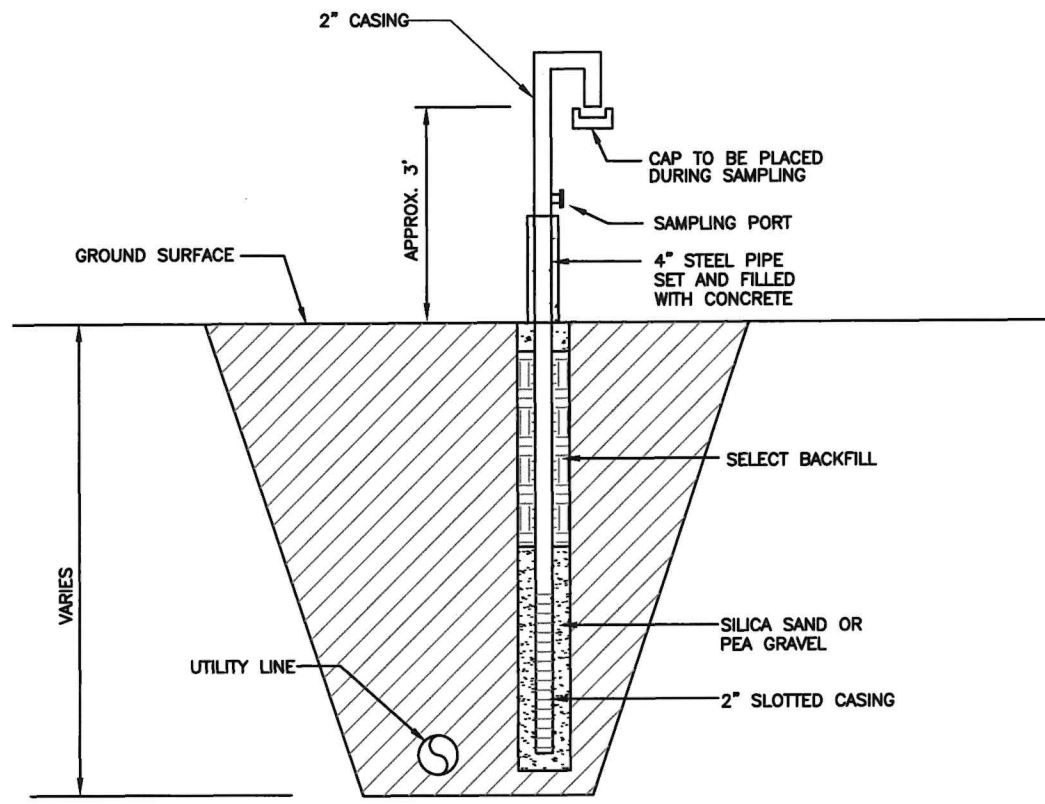

UTILITY VENT MP-2
NTS G1.2

NOTE

1. ALL SIZES AND DIMENSIONS ARE APPROXIMATE.



J. Heath Parker
2/28/2025

MONITORING PROBE/VENT DETAILS	
TEXOMA AREA SOLID WASTE AUTHORITY TASWA DRF PERMIT AMENDMENT	
BME	BIGGS & MATHEWS ENVIRONMENTAL 1700 ROBERT ROAD, STE. 100 MANSFIELD, TEXAS 76063 817-563-1144
TBPE FIRM NO. F-256	DRAWING G1.2
TBPG FIRM NO. 50222	

ISSUED FOR PERMITTING PURPOSES ONLY

O:\TASWA\Drawings\ATT G1.3 Adjacent Structures.dwg Layout: Layout1 User: HParker



0 1000 2000
SCALE IN FEET

LEGEND

- PERMIT BOUNDARY
- LANDFILL FOOTPRINT
- 1/4 MILE RADIUS
- HABITABLE STRUCTURE

NOTES:

1. AERIAL PHOTOGRAPH TAKEN FROM 7.5 MINUTE QUADRANGLE SADLER, TEX AND ETHEL, TEX. DOWNLOADED ON FEBRUARY 10, 2022.



J. Heath Parker
2/28/2025

STRUCTURES WITHIN 1/4 MILE OF PERMIT BOUNDARY
TEXOMA AREA SOLID WASTE AUTHORITY
TASWA DRF
PERMIT AMENDMENT



BIGGS & MATHEWS ENVIRONMENTAL
 1700 ROBERT ROAD, STE. 100
 MANSFIELD, TEXAS 76063
 817-563-1144

TBPE FIRM NO. F-256
 TBPG FIRM NO. 50222

DRAWING
G1.3

ISSUED FOR PERMITTING PURPOSES ONLY

APPENDIX G2
REPORTING AND RECORDING FORMS

**APPENDIX G3
LANDFILL GAS MONITORING
PROBE BORING/COMPLETION LOGS**

LOG OF GAS MONITORING PROBE NO. GMP-2

**Project Description: Texoma Area Solid Waste Authority
Grayson County, Texas**

BIGGS & MATHEWS ENVIRONMENTAL
6031 Interstate 20 West, Suite 242
Arlington, Texas 76017-1045
Phone: 817-563-1144
Fax: 817-563-1224

Depth, feet	Samples	Symbol / USCS	Location: E 4165.680 N 3796.200	Gas Monitoring Probe Construction Details	Hand Penetrometer, tsf	Penetration Blows/Foot	Moisture Content, %	Unit Dry Weight, lb/cu ft.	Liquid Limit	Plastic Limit	Plasticity Index	% Passing No. 200 Sieve	Unc. Compressive Strength, tsf
			Surface El.: 746.50 ft. msl Completion Depth: 23.0 ft. Date Boring Started: 8/30/04 Date Boring Completed: 8/30/04										
			MATERIAL DESCRIPTION										
5			CLAY, brown, yellow-orange, tan and light gray, iron stains, calcareous										
10			SHALEY CLAY, tan and light gray, very stiff to hard, iron stains, manganese dioxide, fine grain, gypsum partings										
15													
20													
25													
30													
35													
40													
45													
50													

Drilling Contractor: **H/ET**
 Drilling Method:
 Sampling Method:
 Geologist/Engineer: **Boyce**
 Project No.: **202.01.200**

Groundwater Observations

Date	Depth

Remarks:



BME LOG TA. 3PJ BME.GDT 9/20/04

LOG OF GAS MONITORING PROBE NO. GMP-2 The stratification lines represent approximate strata boundaries.
 In situ, the transition may be gradual.

j:\202\01\Probe Installation Report\MontProbeDetail-2.dwg Layout: Layout1 User: rpc

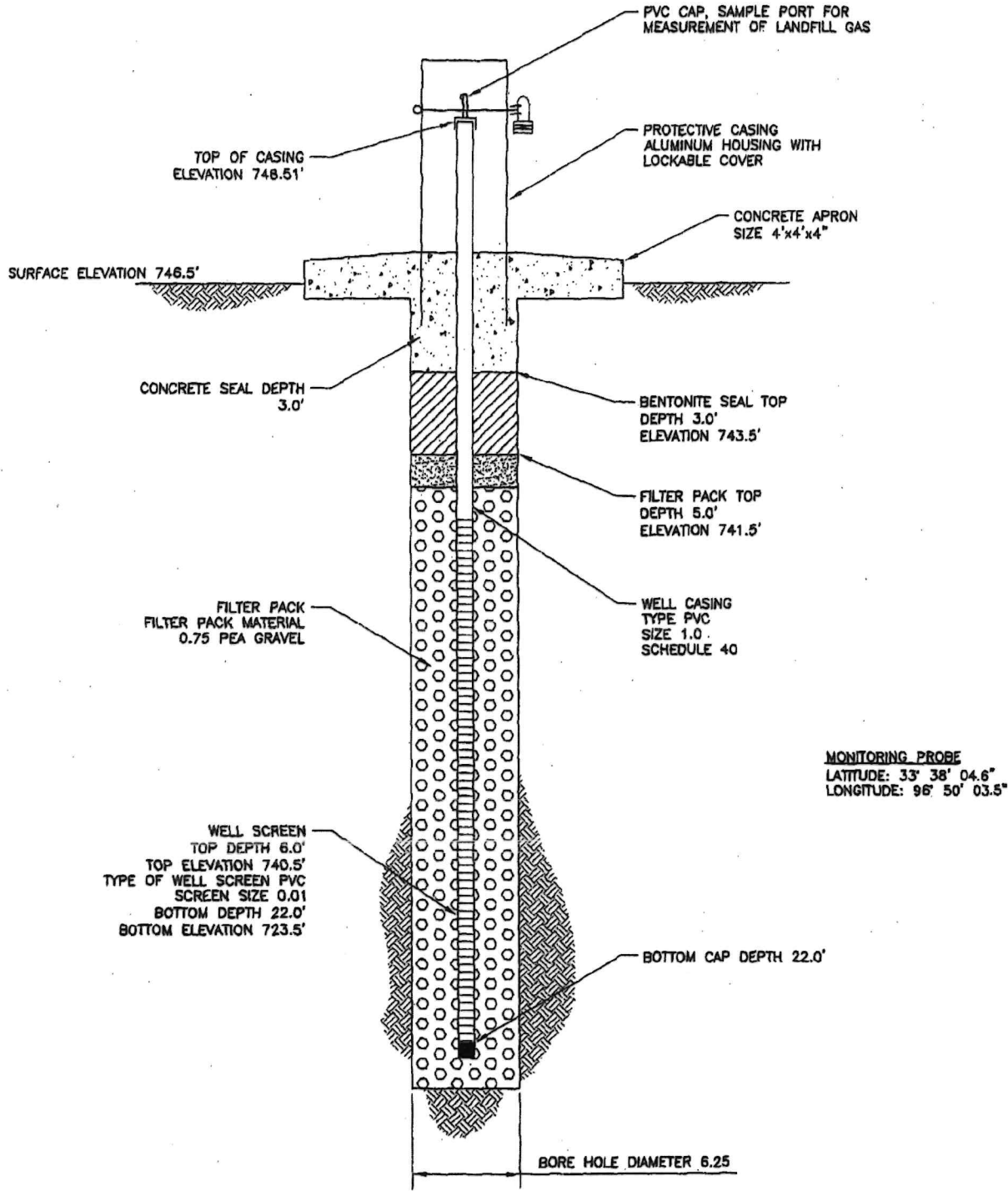

MONITORING PROBE
 LATITUDE: 33° 38' 04.6"
 LONGITUDE: 96° 50' 03.5"

GAS MONITORING PROBE DETAIL
GMP 2

TEXOMA AREA SOLID WASTE AUTHORITY
DISPOSAL AND RECYCLING FACILITY
PROBE INSTALLATION REPORT

BIGGS & MATHEWS
ENVIRONMENTAL
 CONSULTING ENGINEERS
 6031 I-20 WEST, SUITE 242
 ARLINGTON, TEXAS

DSN. MRW	DATE : 09/04	DRAWING 1
DWN. RMP	SCALE : GRAPHIC	
CHK. MRW	DWG : MontProbeDetail-2.dwg	

REVISIONS						
REV	DATE	DESCRIPTION	DWN BY	DES BY	CHK BY	APP BY

LOG OF GAS MONITORING PROBE NO. GMP-3

**Project Description: Texoma Area Solid Waste Authority
Grayson County, Texas**

BIGGS & MATHEWS ENVIRONMENTAL
6031 Interstate 20 West, Suite 242
Arlington, Texas 76017-1045
Phone: 817-563-1144
Fax: 817-563-1224

Depth, feet	Samples	Symbol / USCS	Location: E 3189.570 N 3980.420 Surface El.: 735.00 ft. msl Completion Depth: 15.0 ft. Date Boring Started: 8/30/04 Date Boring Completed: 8/30/04	Gas Monitoring Probe Construction Details	Hand Penetrometer, tsf	Penetration Blows/Foot	Moisture Content, %	Unit Dry Weight, lb/cu ft.	Liquid Limit	Plastic Limit	Plasticity Index	% Passing No. 200 Sieve	Unc. Compressive Strength, tsf
MATERIAL DESCRIPTION													
		[Diagonal Hatching]	CLAY, dark gray, brown to olive brown, yellow-orange and light gray	[Diagonal Hatching]									
5		[Diagonal Hatching]	SHALEY CLAY, yellow-orange and light gray, hard iron stains and sandstone	[Diagonal Hatching]									
		[Horizontal Dashed]	SHALE with sand, gray, soft rock - very hard	[Horizontal Dashed]									
15				[Vertical Dotted]									
20													
25													
30													
35													
40													
45													
50													

Drilling Contractor: H/ET
 Drilling Method:
 Sampling Method:
 Geologist/Engineer: Boyce
 Project No.: 202.01.200

Groundwater Observations	
Date	Depth

Remarks:



BME LOG TA - PJ BME.GDT 9/20/04

j:\202\01\Probe Installation Report\MontProbeDetail-3.dwg Layout: Layout1 User: rf

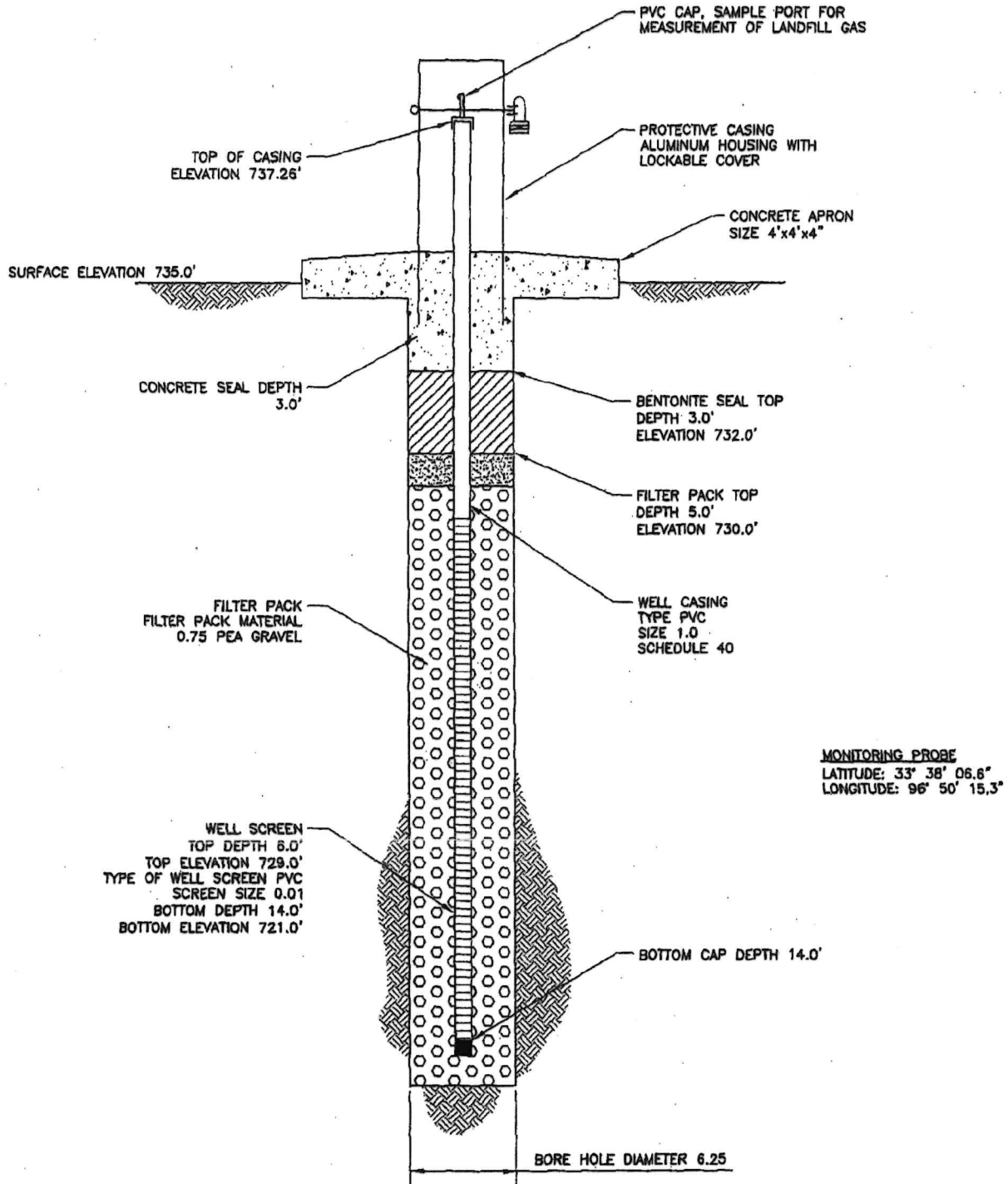

**GAS MONITORING PROBE DETAIL
GMP 3**

**TEXOMA AREA SOLID WASTE AUTHORITY
DISPOSAL AND RECYCLING FACILITY
PROBE INSTALLATION REPORT**

**BIGGS & MATHEWS
ENVIRONMENTAL**
CONSULTING ENGINEERS
6031 I-20 WEST, SUITE 242
ARLINGTON, TEXAS

DSN. MRW	DATE : 08/04	DRAWING
DWN. RMP	SCALE : GRAPHIC	2
CHK. MRW	DWG : MontProbeDetail-3.dwg	

REVISIONS						
REV	DATE	DESCRIPTION	DWN BY	DES BY	CHK BY	APP BY

LOG OF GAS MONITORING PROBE NO. GMP-4

Project Description: **Texoma Area Solid Waste Authority**
Grayson County, Texas

BIGGS & MATHEWS ENVIRONMENTAL
 6031 Interstate 20 West, Suite 242
 Arlington, Texas 76017-1045
 Phone: 817-563-1144
 Fax: 817-563-1224

Depth, feet	Samples	Symbol / USCS	Location: E 2220.550 N 4166.650	Gas Monitoring Probe Construction Details	Hand Penetrometer, tsf	Penetration Blows/Foot	Moisture Content, %	Unit Dry Weight, lb/cu ft.	Liquid Limit	Plastic Limit	Plasticity Index	% Passing No. 200 Sieve	Unc. Compressive Strength, tsf	MATERIAL DESCRIPTION	
														Surface El.: 749.50 ft. msl	Completion Depth: 20.0 ft.
5														CLAY, dark, gray brown to yellowish brown, firm to very stiff	743.50
10														SHALEY CLAY, yellow-tan and light gray, very stiff to hard iron stains	729.50
15															
20															
25															
30															
35															
40															
45															
50															
Drilling Contractor: H/ET Drilling Method: Sampling Method: Geologist/Engineer: Boyce Project No.: 202.01.200			Groundwater Observations Date Depth		Remarks:										

BME LOG T.A.S. 303U BME.GDT 9/20/04

LOG OF GAS MONITORING PROBE NO. GMP-4 The stratification lines represent approximate strata boundaries.
 PAGE 1 OF 1 In situ, the transition may be gradual.

J:\2002\01\Probe Installation Report\MontProbeDetail-4.dwg Layout: Layout1 User: rf

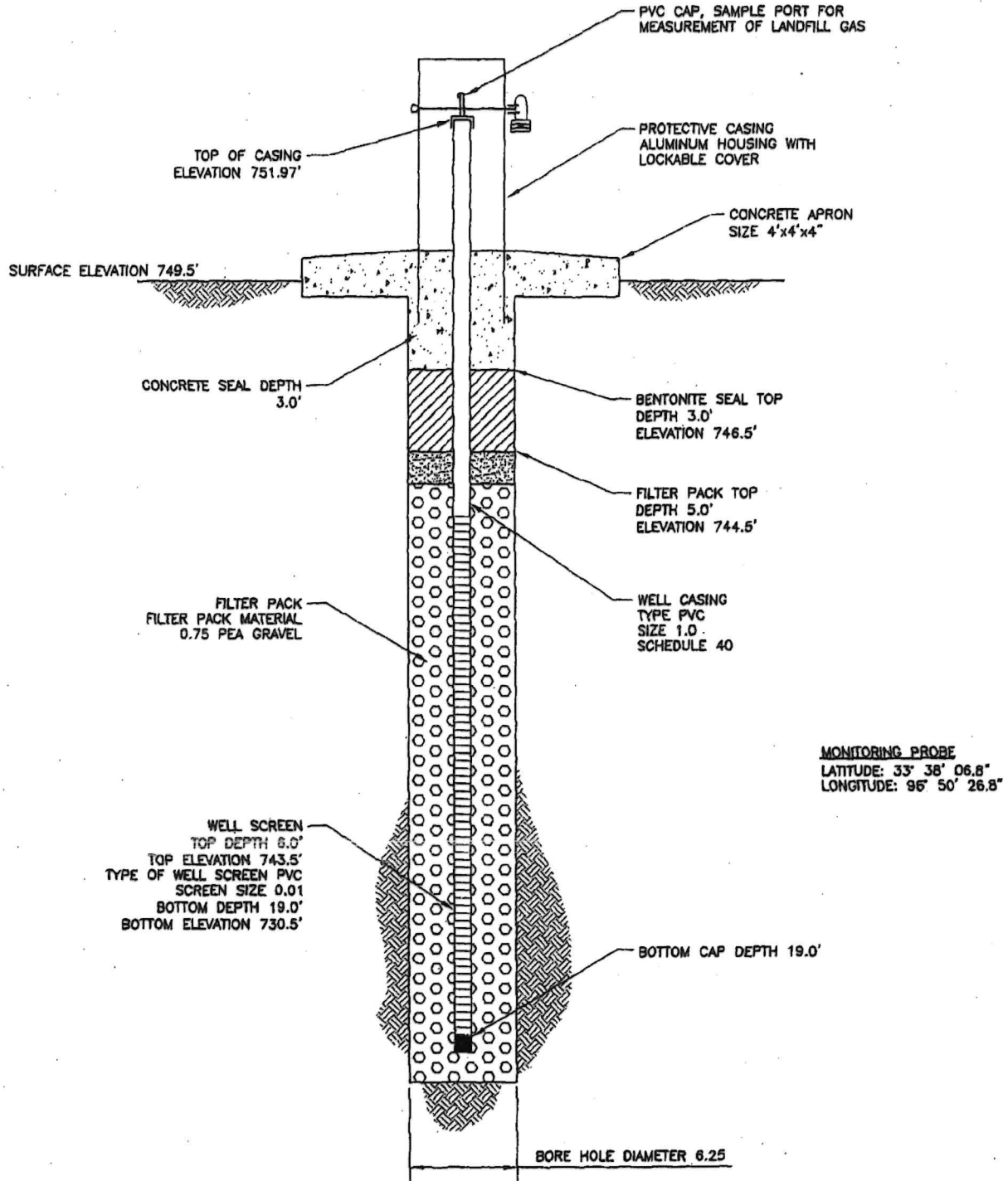

MONITORING PROBE
 LATITUDE: 33° 38' 06.8"
 LONGITUDE: 96° 50' 26.8"

**GAS MONITORING PROBE DETAIL
 GMP 4**

**TEXOMA AREA SOLID WASTE AUTHORITY
 DISPOSAL AND RECYCLING FACILITY
 PROBE INSTALLATION REPORT**



**BIGGS & MATHEWS
 ENVIRONMENTAL**
 CONSULTING ENGINEERS
 6031 I-20 WEST, SUITE 242
 ARLINGTON, TEXAS

REVISIONS						
REV	DATE	DESCRIPTION	DWN BY	DES BY	CHK BY	APP BY

DSN. MRW	DATE : 09/04
DWN. RMP	SCALE : GRAPHIC
CHK. MRW	DWG : MontProbeDetail-4.dwg

DRAWING
3

LOG OF GAS MONITORING PROBE NO. GMP-5

Project Description: **Texoma Area Solid Waste Authority**

Grayson County, Texas

BIGGS & MATHEWS ENVIRONMENTAL
 6031 Interstate 20 West, Suite 242
 Arlington, Texas 76017-1045
 Phone: 817-563-1144
 Fax: 817-563-1224

Depth, feet	Samples	Symbol / USCS	Location: E 1216.350 N 4358.830	Gas Monitoring Probe Construction Details	Hand Penetrometer, tsf	Penetration Blows/Foot	Moisture Content, %	Unit Dry Weight, lb/cu ft.	Liquid Limit	Plastic Limit	Plasticity Index	% Passing No. 200 Sieve	Unc. Compressive Strength, tsf													
			Surface El.: 759.00 ft. msl Completion Depth: 20.0 ft. Date Boring Started: 8/30/04 Date Boring Completed: 8/30/04																							
			MATERIAL DESCRIPTION																							
5			CLAY, dark gray brown to olive brown and light gray, firm to hard 754.00																							
10			SHALEY CLAY, yellow-orange and light gray, hard, iron stains 748.00																							
15			SANDSTONE, yellow-orange, hard 746.00																							
20			SHALE with sand, gray, soft rock, carbonaceous 739.00																							
25																										
30																										
35																										
40																										
45																										
50																										
Drilling Contractor: H/ET Drilling Method: Sampling Method: Geologist/Engineer: Project No.: 202.01.200			<table border="1" style="width: 100%; border-collapse: collapse;"> <thead> <tr> <th colspan="2">Groundwater Observations</th> </tr> <tr> <th>Date</th> <th>Depth</th> </tr> </thead> <tbody> <tr><td> </td><td> </td></tr> <tr><td> </td><td> </td></tr> <tr><td> </td><td> </td></tr> <tr><td> </td><td> </td></tr> </tbody> </table>		Groundwater Observations		Date	Depth									Remarks:									
Groundwater Observations																										
Date	Depth																									

BME LOG TA. .SFPJ BME.GDT 9/20/04



LOG OF GAS MONITORING PROBE NO. GMP-5 The stratification lines represent approximate strata boundaries. In situ, the transition may be gradual.

J:\202\01\Probe Installation Report\MontProbeDetail-5.dwg Layout: Layout1 User: r

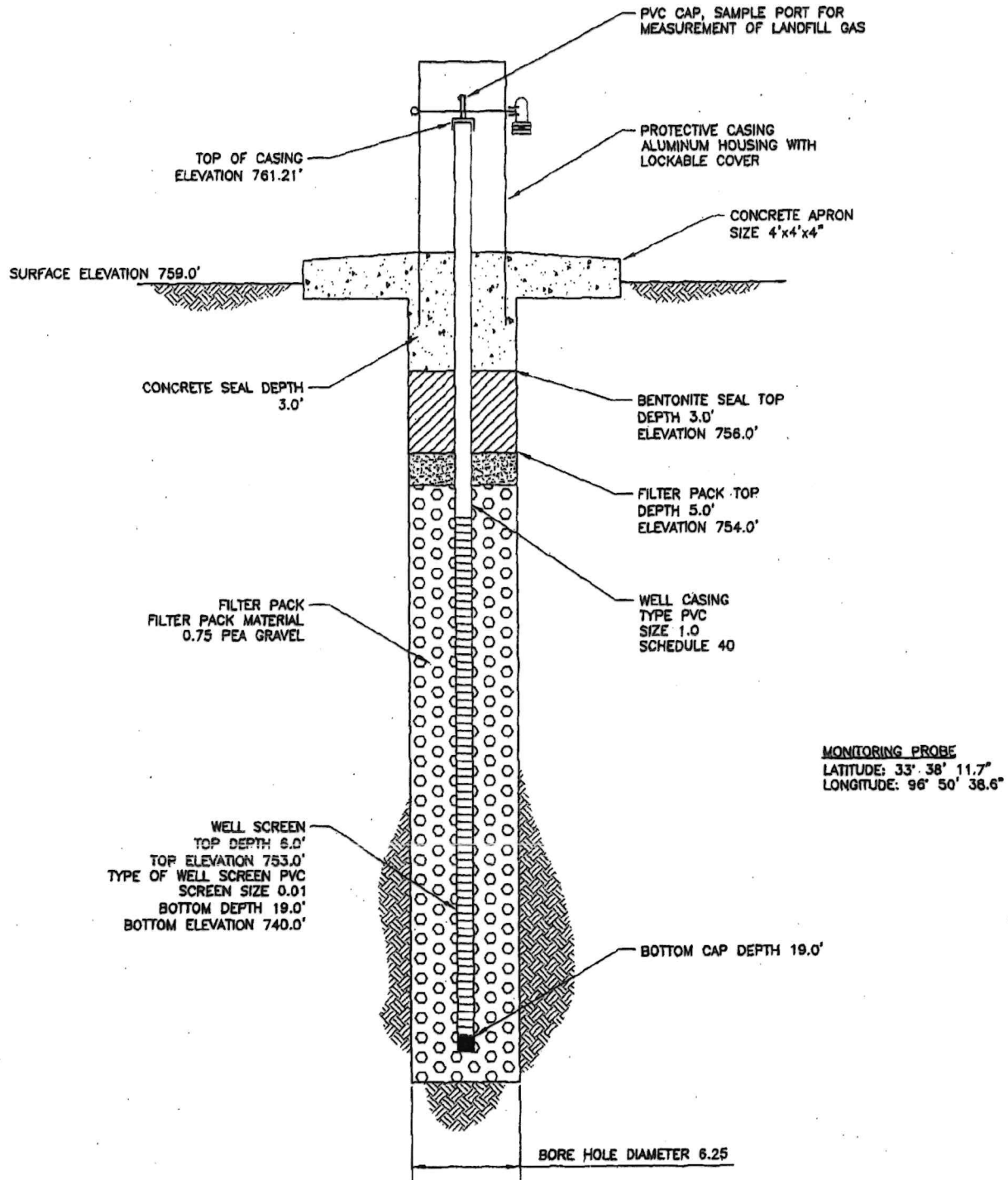

**GAS MONITORING PROBE DETAIL
GMP 5**

**TEXOMA AREA SOLID WASTE AUTHORITY
DISPOSAL AND RECYCLING FACILITY
PROBE INSTALLATION REPORT**



**BIGGS & MATHEWS
ENVIRONMENTAL**
CONSULTING ENGINEERS
6031 I-20 WEST, SUITE 242
ARLINGTON, TEXAS

REVISIONS						
REV	DATE	DESCRIPTION	DWN BY	DES BY	CHK BY	APP BY

DSN. MRW	DATE : 09/04
DWN. RMP	SCALE : GRAPHIC
CHK. MRW	DWG : MontProbeDetail-5.dwg

DRAWING
4

LOG OF GAS MONITORING PROBE NO. GMP-6

Project Description: **Texoma Area Solid Waste Authority**
Grayson County, Texas

BIGGS & MATHEWS ENVIRONMENTAL
 6031 Interstate 20 West, Suite 242
 Arlington, Texas 76017-1045
 Phone: 817-563-1144
 Fax: 817-563-1224

Depth, feet	Samples	Symbol / USCS	Location: E 506.670 N 4250.410	Gas Monitoring Probe Construction Details	Hand Penetrometer, tsf	Penetration Blows/Foot	Moisture Content, %	Unit Dry Weight, lb/cu ft.	Liquid Limit	Plastic Limit	Plasticity Index	% Passing No. 200 Sieve	Unc. Compressive Strength, tsf
			Surface El.: 756.00 ft. msl Completion Depth: 41.0 ft. Date Boring Started: 8/30/04 Date Boring Completed: 8/30/04										
MATERIAL DESCRIPTION													
5			SHALEY SAND with sandy shale, yellow-orange, soft rock, iron stains, calcareous, sandstone at top 751.00										
10			SHALE with sand, olive green, yellow-orange and yellow, iron stains, carbonaceous 715.00										
15													
20													
25													
30													
35													
40													
45													
50													

BME LOG TA. 3PJ BME.GDT 9/20/04

Drilling Contractor: **H/ET**
 Drilling Method:
 Sampling Method:
 Geologist/Engineer: **Boyce**
 Project No.: **202.01.200**

Groundwater Observations	
Date	Depth

Remarks:



LOG OF GAS MONITORING PROBE NO. GMP-6 The stratification lines represent approximate strata boundaries. In situ, the transition may be gradual.

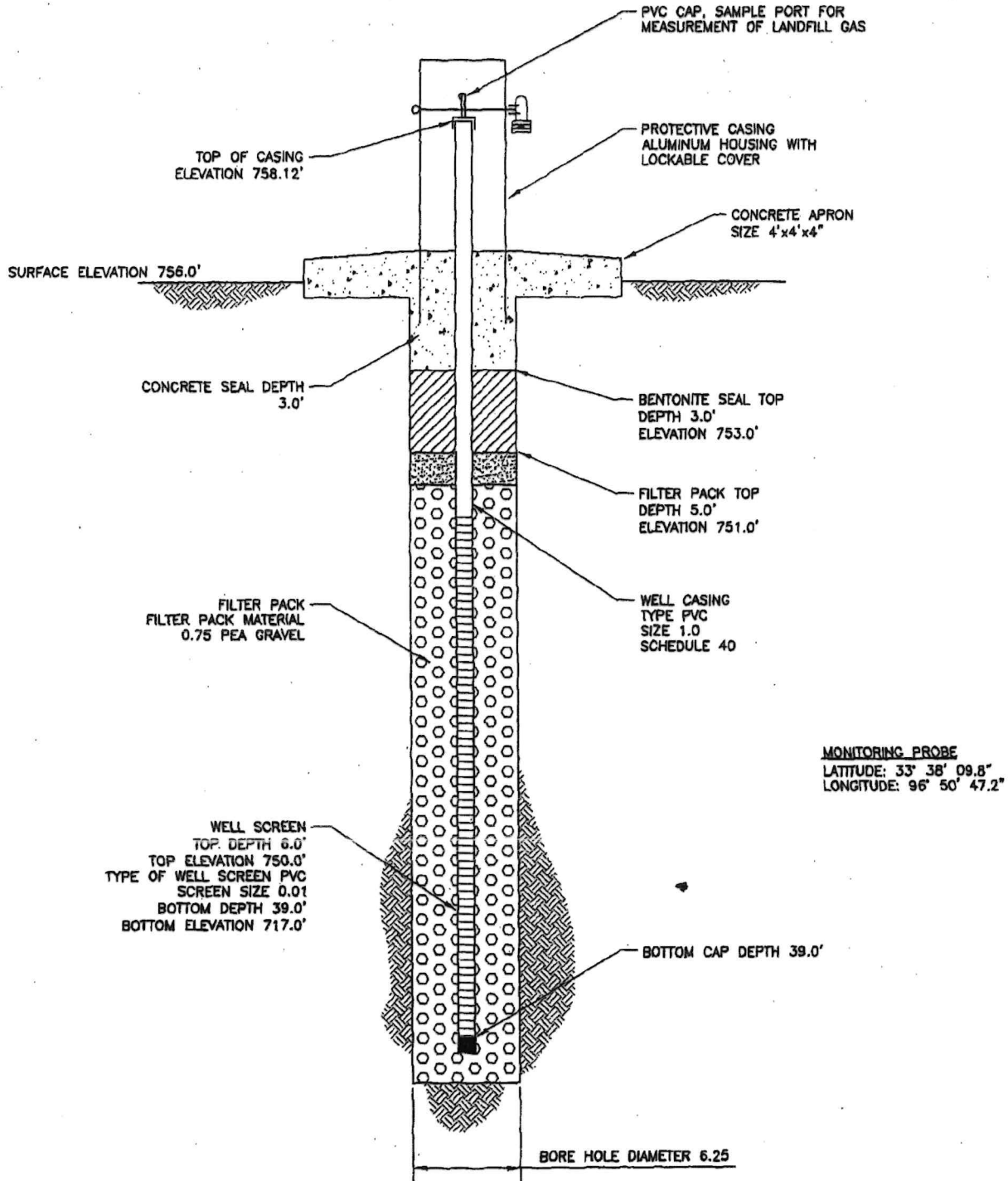

MONITORING PROBE
 LATITUDE: 33° 38' 09.8"
 LONGITUDE: 96° 50' 47.2"

**GAS MONITORING PROBE DETAIL
 GMP 6**

**TEXOMA AREA SOLID WASTE AUTHORITY
 DISPOSAL AND RECYCLING FACILITY
 PROBE INSTALLATION REPORT**



**BIGGS & MATHEWS
 ENVIRONMENTAL
 CONSULTING ENGINEERS
 6031 I-20 WEST, SUITE 242
 ARLINGTON, TEXAS**

REVISIONS						
REV	DATE	DESCRIPTION	DWN BY	DES BY	CHK BY	APP BY

DSN. MRW DATE : 09/04
 DWN. RMP SCALE : GRAPHIC
 CHK. MRW DWG : MontProbeDetail-6.dwg

DRAWING
5

LOG OF GAS MONITORING PROBE NO. GMP-7

Project Description: **Texoma Area Solid Waste Authority**
Grayson County, Texas

BIGGS & MATHEWS ENVIRONMENTAL
 6031 Interstate 20 West, Suite 242
 Arlington, Texas 76017-1045
 Phone: 817-563-1144
 Fax: 817-563-1224

Depth, feet	Samples	Symbol / USCS	Location: E 506.580 N 3244.620	Gas Monitoring Probe Construction Details	Hand Penetrometer, tsf	Penetration Blows/Foot	Moisture Content, %	Unit Dry Weight, lb/cu ft.	Liquid Limit	Plastic Limit	Plasticity Index	% Passing No. 200 Sieve	Unc. Compressive Strength, tsf
			Surface El.: 755.50 ft. msl Completion Depth: 41.0 ft. Date Boring Started: 8/30/04 Date Boring Completed: 8/30/04										
MATERIAL DESCRIPTION													
5		CLAY	CLAY, dark gray-brown to yellowish brown, firm to very stiff	749.50									
10		SHALEY SAND	SHALEY SAND with sandy shale, yellow-orange, soft rock, iron stains, calcareous sandstone at top	745.50									
15		SHALE	SHALE with sand, olive gray, yellow-orange and yellow, iron stains, carbonaceous										
20		MUDSTONE	- mudstone										
25		MUDSTONE	- mudstone										
30		MUDSTONE	- mudstone										
35		MUDSTONE	- mudstone										
40		MUDSTONE	- mudstone	714.50									
45		MUDSTONE	- mudstone										
50		MUDSTONE	- mudstone										

BME LOG TA JPU BME.GDT 9/20/04

Drilling Contractor: **H/ET**
 Drilling Method:
 Sampling Method:
 Geologist/Engineer: **Boyce**
 Project No.: **202.01.200**

Groundwater Observations	
Date	Depth

Remarks:



LOG OF GAS MONITORING PROBE NO. GMP-7 The stratification lines represent approximate strata boundaries. In situ, the transition may be gradual.

J:\202\01\Probe Installation Report\MontProbeDetail-7.dwg Layout: Layout1 User: rf

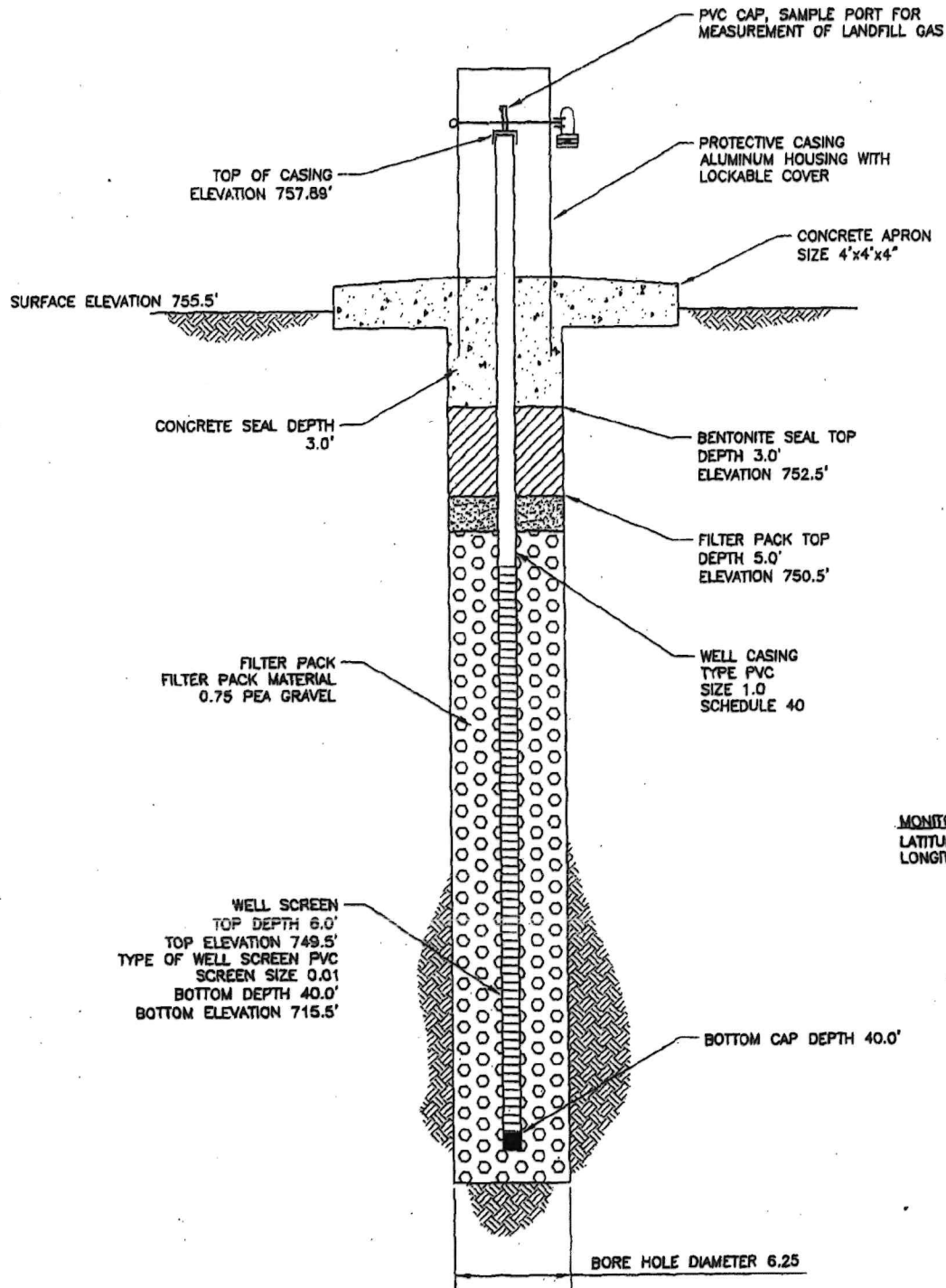

MONITORING PROBE
 LATITUDE: 33° 38' 00.5"
 LONGITUDE: 96° 50' 47.4"

**GAS MONITORING PROBE DETAIL
 GMP 7**

**TEXOMA AREA SOLID WASTE AUTHORITY
 DISPOSAL AND RECYCLING FACILITY
 PROBE INSTALLATION REPORT**



**BIGGS & MATHEWS
 ENVIRONMENTAL**
 CONSULTING ENGINEERS
 6031 I-20 WEST, SUITE 242
 ARLINGTON, TEXAS

REVISIONS						
REV	DATE	DESCRIPTION	DWN BY	DES BY	CHK BY	APP BY

DSN. MRW	DATE : 09/04
DWN. RMP	SCALE : GRAPHIC
CHK. MRW	DWG : MontProbeDetail-7.dwg

DRAWING
6

LOG OF GAS MONITORING PROBE NO. GMP-8

**Project Description: Texoma Area Solid Waste Authority
Grayson County, Texas**

BIGGS & MATHEWS ENVIRONMENTAL
6031 Interstate 20 West, Suite 242
Arlington, Texas 76017-1045
Phone: 817-583-1144
Fax: 817-583-1224

Depth, feet	Samples	Symbol / USCS	Location: E 508.520 N 2244.010 Surface El.: 759.50 ft. msl Completion Depth: 45.0 ft. Date Boring Started: 8/31/04 Date Boring Completed: 9/31/04	Gas Monitoring Probe Construction Details	Hand Penetrometer, tsf	Penetration Blows/Foot	Moisture Content, %	Unit Dry Weight, lb/cu ft.	Liquid Limit	Plastic Limit	Plasticity Index	% Passing No. 200 Sieve	Unc. Compressive Strength, tsf
			MATERIAL DESCRIPTION										
			CLAY, dark gray brown, firm to very stiff	A-1									
5			754.50 SHALEY CLAY, yellow-tan and light gray, very stiff to hard, iron stains	A-1									
10			750.50 SHALEY SAND, yellow-orange to brown, fine to very fine, soft rock, iron stains	A-1									
15				A-1									
20			740.50 SHALE with sand, olive gray, yellow, iron stains, carbonaceous	A-1									
25				A-1									
30				A-1									
35			- mudstone lines	A-1									
40				A-1									
45			714.50	A-1									
50				A-1									

BME LOG TA, GPJ BME.GDT 9/20/04

Drilling Contractor: **H/ET**
 Drilling Method:
 Sampling Method:
 Geologist/Engineer: **Boyce**
 Project No.: **202.01.200**

Groundwater Observations	
Date	Depth

Remarks:



LOG OF GAS MONITORING PROBE NO. GMP-8 The stratification lines represent approximate strata boundaries. In situ, the transition may be gradual.

J:\202\01\Probe Installation Report\MontProbeDetail-8.dwg Layout: Layout1 User: rf

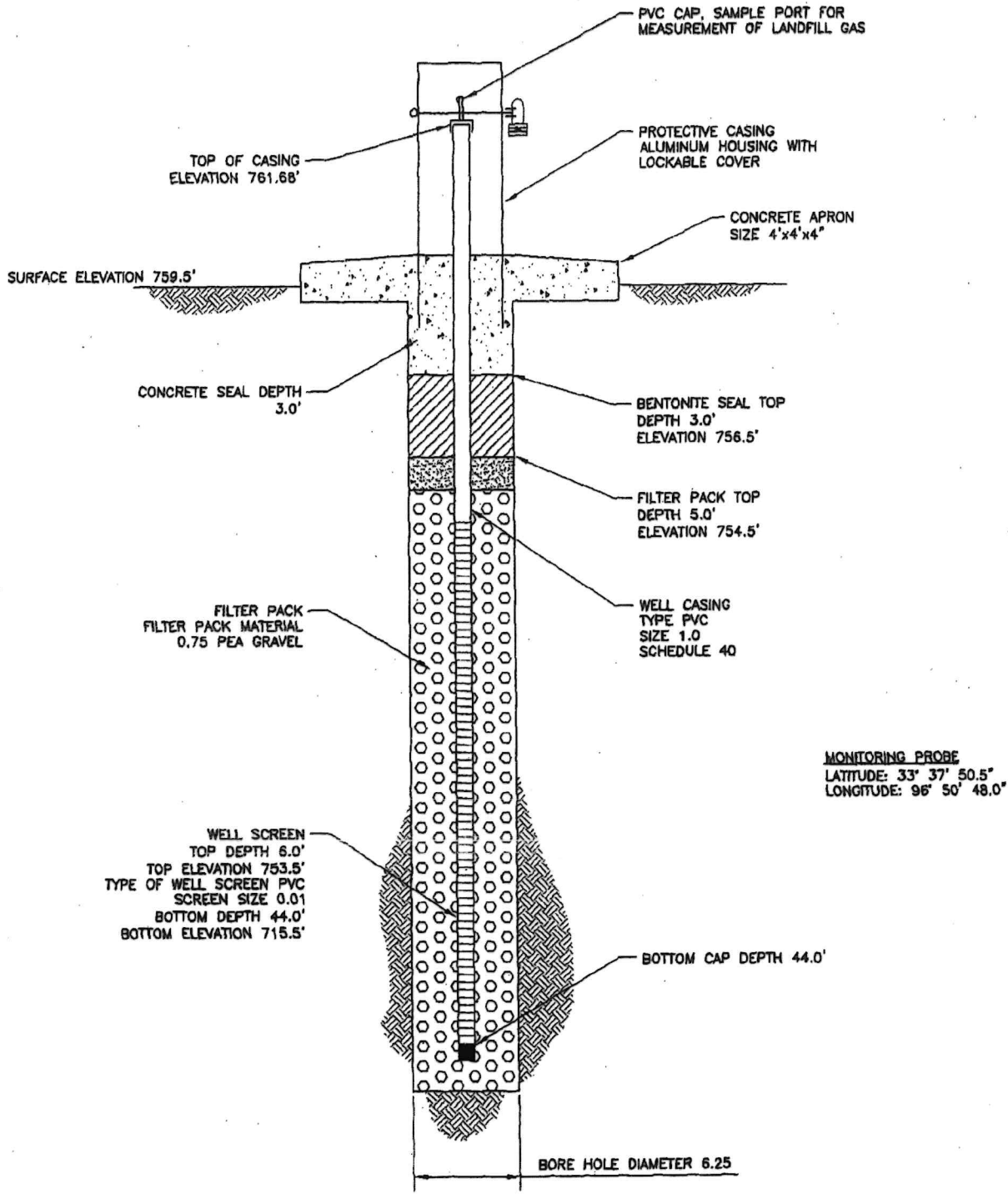

MONITORING PROBE
 LATITUDE: 33° 37' 50.5"
 LONGITUDE: 96° 50' 48.0"

GAS MONITORING PROBE DETAIL
GMP 8

TEXOMA AREA SOLID WASTE AUTHORITY
DISPOSAL AND RECYCLING FACILITY
PROBE INSTALLATION REPORT

BIGGS & MATHEWS
ENVIRONMENTAL
 CONSULTING ENGINEERS
 6031 I-20 WEST, SUITE 242
 ARLINGTON, TEXAS

DSN. MRW	DATE : 09/04	DRAWING 7
DWN. RMP	SCALE : GRAPHIC	
CHK. MRW	DWG : MontProbeDetail-8.dwg	

REVISIONS						
REV	DATE	DESCRIPTION	DWN BY	DES BY	CHK BY	APP BY

LOG OF GAS MONITORING PROBE NO. GMP-9

**Project Description: Texoma Area Solid Waste Authority
Grayson County, Texas**

BIGGS & MATHEWS ENVIRONMENTAL
6031 Interstate 20 West, Suite 242
Arlington, Texas 76017-1045
Phone: 817-563-1144
Fax: 817-563-1224

Depth, feet	Samples	Symbol / USCS	Location: E 510.090 N 1223.280	Gas Monitoring Probe Construction Details	Hand Penetrometer, tsf	Penetration Blows/Foot	Moisture Content, %	Unit Dry Weight, lb/cu ft.	Liquid Limit	Plastic Limit	Plasticity Index	% Passing No. 200 Sieve	Unc. Compressive Strength, tsf
			Surface El.: 756.00 ft. msl Completion Depth: 41.0 ft. Date Boring Started: 8/31/04 Date Boring Completed: 8/31/04										
			MATERIAL DESCRIPTION										
			CLAY, dark gray brown, firm to very stiff										
5			SHALEY CLAY, yellow-tan, light-gray, very stiff to hard, iron stains										
10													
15			SHALE with sand, olive gray, yellow iron stains, carbonaceous										
20													
25													
30													
35													
40													
45													
50													
			Drilling Contractor: H/ET Drilling Method: Sampling Method: Geologist/Engineer: Boyce Project No.: 202.01.200	Groundwater Observations Date Depth _____ _____ _____	Remarks: Installed monitoring well upon completion of borehole.								

BIME LOG T. GPJ BIME.GDT 9/20/04



LOG OF GAS MONITORING PROBE NO. GMP-9 The stratification lines represent approximate strata boundaries. In situ, the transition may be gradual.

j:\202\01\Probe Installation Report\MontProbeDetail-9.dwg Layout: Layout1 User: rf

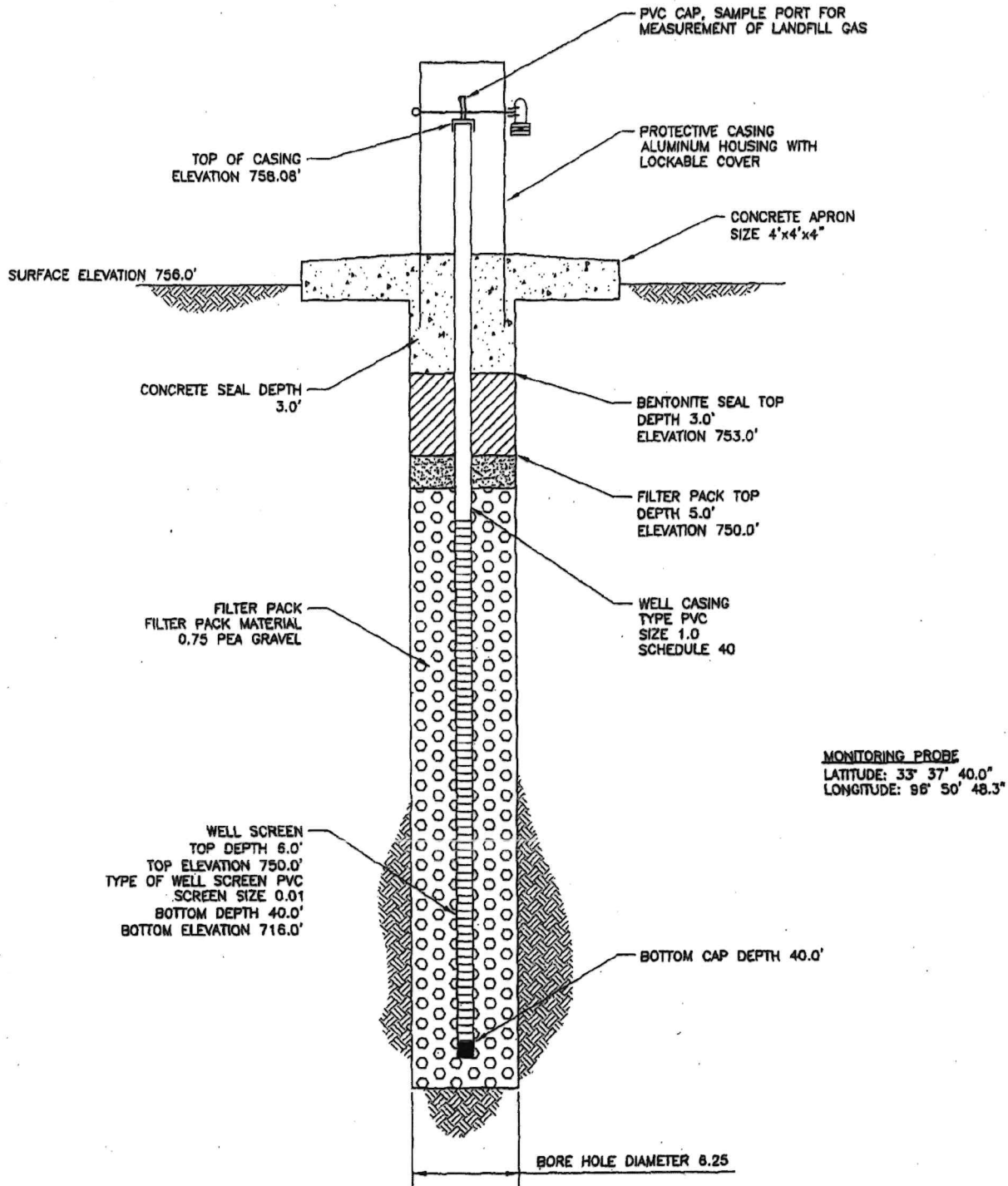

**GAS MONITORING PROBE DETAIL
GMP 9**

**TEXOMA AREA SOLID WASTE AUTHORITY
DISPOSAL AND RECYCLING FACILITY
PROBE INSTALLATION REPORT**



**BIGGS & MATHEWS
ENVIRONMENTAL
CONSULTING ENGINEERS**
 6031 I-20 WEST, SUITE 242
 ARLINGTON, TEXAS

REVISIONS							OSN. MRW	DATE : 09/04	DRAWING 8
REV	DATE	DESCRIPTION	DWN BY	DES BY	CHK BY	APP BY	DWN. RMP	SCALE : GRAPHIC	
							CHK. MRW	DWG : MontProbeDetail-9.dwg	

LOG OF GAS MONITORING PROBE NO. GMP-10

Project Description: **Texoma Area Solid Waste Authority**
Grayson County

Biggs and Mathews Environmental
 1700 Robert Road, Ste 100
 Mansfield, Texas 76063-6892
 Phone: 817-563-1144

Depth, feet	Samples	Symbol / USCS	Location: E 2472202.2 N 7278580.1	Hand Penetrometer, tsf	Penetration Blows/Foot	Moisture Content, %	Unit Dry Weight, lb/cu ft.	Liquid Limit	Plastic Limit	Plasticity Index	% Passing No. 200 Sieve	Unc. Compressive Strength, tsf
			Surface El.: 766.68 ft. msl									
			Completion Depth: 64.0 ft.									
			Date Boring Started: 3/24/2022									
			Date Boring Completed: 3/28/2022									
MATERIAL DESCRIPTION												
5		Clay, dark brown, stiff	760.18									
10		Clay, shaley, tan, stiff										
15												
20												
25												
30		Shale, with sand, dark gray, hard	736.68									
35												
40		Shale, with sand, dark gray, hard	726.68									
45												
50												
Contractor: H/ET			Groundwater Observations		Remarks:							
Project No.:			Date	Depth								

TARZAN 2022 TASWA2022.GPJ BAM DATA TEMPLATE.GDT 10/13/22

The stratification lines represent approximate strata boundaries. In situ, the transition may be gradual.
 LOGS ARE NOT INTENDED TO BE USED SEPARATELY FROM THE ORIGINAL REPORT.

Continued Next Page

LOG OF GAS MONITORING PROBE NO. GMP-10

**Project Description: Texoma Area Solid Waste Authority
Grayson County**

**Biggs and Mathews Environmental
1700 Robert Road, Ste 100
Mansfield, Texas 76063-5892
Phone: 817-563-1144**

Depth, feet	Samples	Symbol / USCS	Location: E 2472202.2 N 7278580.1	Hand Penetrometer, tsf	Penetration Blows/Foot	Moisture Content, %	Unit Dry Weight, lb/cu ft.	Liquid Limit	Plastic Limit	Plasticity Index	% Passing No. 200 Sieve	Unc. Compressive Strength, tsf	
			Surface El.: 766.68 ft. msl Completion Depth: 64.0 ft. Date Boring Started: 3/24/2022 Date Boring Completed: 3/28/2022										
			MATERIAL DESCRIPTION										
55			Shale, with sand, dark gray, hard <i>(continued)</i>										
60													
65			702.68										
70													
75													
80													
85													
90													
95													
100													
Contractor: H/ET Project No.:			Groundwater Observations Date Depth _____ _____ _____	Remarks:									

TARZAN 2022 TASMA2022.GPJ B&M DATA TEMPLATE.GDT 10/13/22

The stratification lines represent approximate strata boundaries. In situ, the transition may be gradual.
LOGS ARE NOT INTENDED TO BE USED SEPARATELY FROM THE ORIGINAL REPORT.

C:\Users\dclark\AppData\Roaming\Carlson Software\Carlson2022\CA010_1_X64\USER\...pdf_tmp.dwg Layout: GP-10 User: dclark

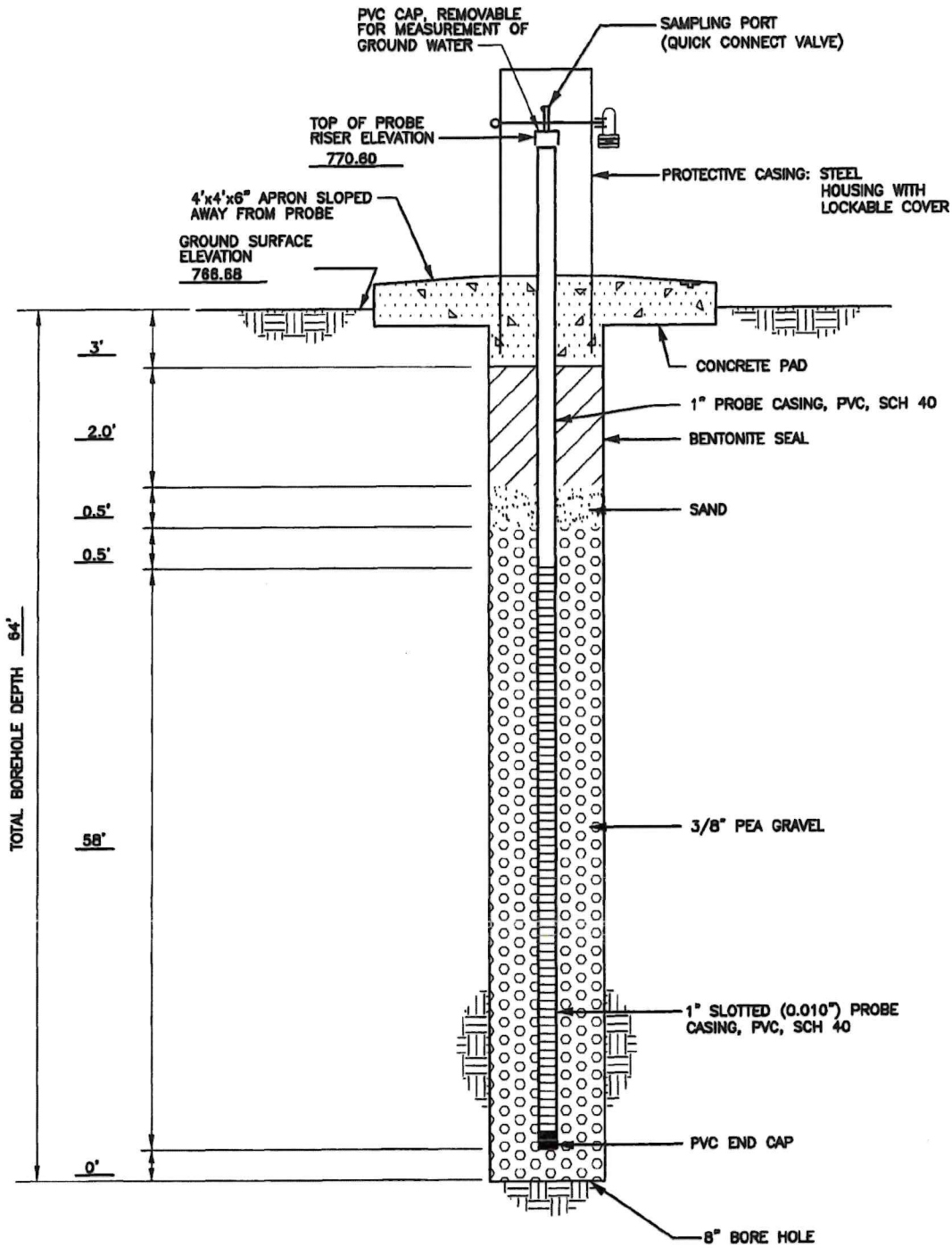



INSTALLATION REPORT GAS MONITORING WELL	
TEXOMA AREA SOLID WASTE AUTHORITY TASWA DRF	
BME	BIGGS & MATHEWS ENVIRONMENTAL 1700 ROBERT ROAD, STE. 100 MANSFIELD, TEXAS 78063 817-563-1144
	FIGURE GP-10
TBPE FIRM NO. F-256	
TBPC FIRM NO. 50222	

LOG OF GAS MONITORING PROBE NO. GMP-11

Project Description: **Texoma Area Solid Waste Authority**
Grayson County

Biggs and Mathews Environmental
 1700 Robert Road, Ste 100
 Mansfield, Texas 76063-5892
 Phone: 817-563-1144

Depth, feet	Samples	Symbol / USCS	Location: E 2473202.4 N 7278534.6	Surface El.: 768.21 ft. msl	Completion Depth: 66.0 ft.	Date Boring Started: 3/24/2022	Date Boring Completed: 3/28/2022	Hand Penetrometer, tsf	Penetration Blows/Foot	Moisture Content, %	Unit Dry Weight, lb/cu ft.	Liquid Limit	Plastic Limit	Plasticity Index	% Passing No. 200 Sieve	Unc. Compressive Strength, tsf	MATERIAL DESCRIPTION	
5																		Clay, dark brown, stiff
760.21																		
10																		Clay, shaley, tan and gray, hard
734.21																		
35																		Shale, sandy, dark gray, hard
50																		
Contractor: H/ET			Groundwater Observations		Remarks:													
Project No.:			Date	Depth														

TARZAN 2022 TASWA2022 GPJ B&M DATA TEMPLATE.GDT 10/13/22



LOG OF GAS MONITORING PROBE NO. GMP-11

Project Description: **Texoma Area Solid Waste Authority**
Grayson County

Biggs and Mathews Environmental
 1700 Robert Road, Ste 100
 Mansfield, Texas 76063-6892
 Phone: 817-563-1144

Depth, feet	Samples	Symbol / USCS	Location: E 2473202.4 N 7278534.6		Hand Penetrometer, tsf	Penetration Blows/Foot	Moisture Content, %	Unit Dry Weight, lb/cu ft.	Liquid Limit	Plastic Limit	Plasticity Index	% Passing No. 200 Sieve	Unc. Compressive Strength, tsf
			Surface El.: 768.21 ft. msl	Completion Depth: 66.0 ft.									
			Date Boring Started: 3/24/2022										
			Date Boring Completed: 3/28/2022										
MATERIAL DESCRIPTION													
55			Shale, sandy, dark gray, hard <i>(continued)</i>										
60													
65					702.21								
70													
75													
80													
85													
90													
95													
100													
Contractor: H/ET			Groundwater Observations		Remarks:								
Project No.:			Date	Depth									

TARZAN 2022 TASWA2022 GPJ B&M DATA TEMPLATE GDT 10/13/22

The stratification lines represent approximate strata boundaries. In situ, the transition may be gradual.
 LOGS ARE NOT INTENDED TO BE USED SEPARATELY FROM THE ORIGINAL REPORT.

C:\Users\dclark\AppData\Roaming\Carlson Software\Carlson2022\CAD10_1_X64\USER\...pdf_imp.dwg Layout: GP-11 User: dclark

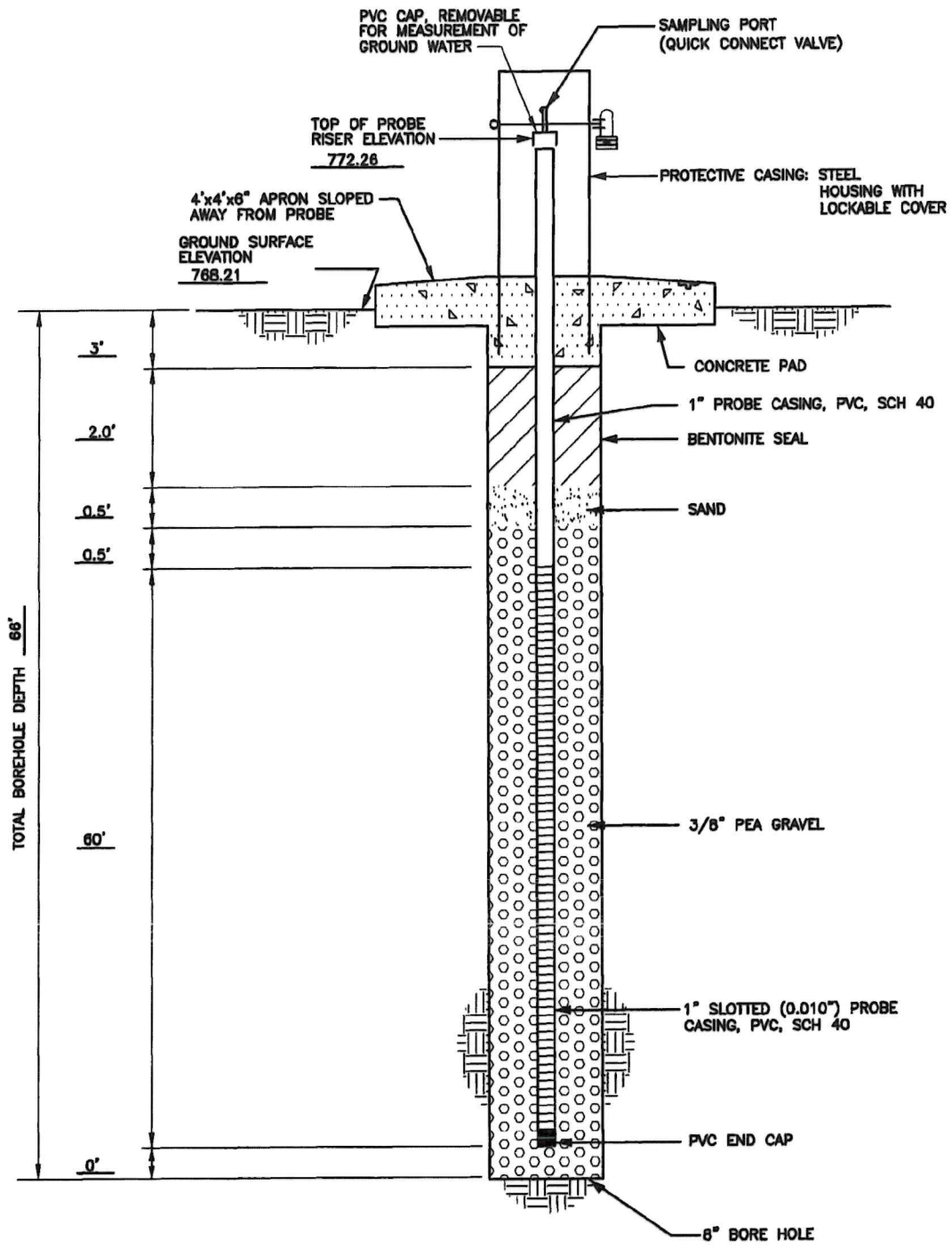

INSTALLATION REPORT GAS MONITORING WELL	
TEXOMA AREA SOLID WASTE AUTHORITY TASWA DRF	
BME	BIGGS & MATHEWS ENVIRONMENTAL 1700 ROBERT ROAD, STE. 100 MANSFIELD, TEXAS 76063 817-563-1144
	FIGURE GP-11
TBPE FIRM NO. F-256	
TBPG FIRM NO. 50222	

APPENDIX G4
LANDFILL GAS COLLECTION AND CONTROL SYSTEM PLAN

C:\TASWA\Drawings\ATT G4.1 GCCS Plan.dwg Layout: G4.1 User: HParker

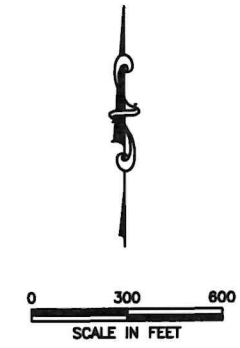

LEGEND

- PERMIT BOUNDARY
- LIMIT OF WASTE
- N 7279000 STATE PLANE COORDINATES
- 750 EXISTING GROUND CONTOUR
- 1000 FINAL COVER CONTOUR
- ⊗ PROPOSED LFG EXTRACTION WELL
- PROPOSED LFG COLLECTION PIPING
- ◆ PROPOSED CONDENSATE SUMP
- ⊗ PROPOSED LFG ISOLATION VALVE

NOTES:

1. EXISTING GROUND CONTOURS PROVIDED BY BIGGS AND MATHEWS ENVIRONMENTAL FROM DRONE SURVEY FLOWN ON JUNE 1, 2022.
2. THE LOCATION AND NUMBER OF PROPOSED FUTURE EXTRACTION WELLS AND GCCS COMPONENTS ARE APPROXIMATE. EXACT NUMBER AND LOCATIONS WILL BE DETERMINED BASED ON SITE CONDITIONS AT THE TIME OF INSTALLATION.



J. Heath Parker
2/28/2025

LANDFILL GAS COLLECTION SYSTEM PLAN
TEXOMA AREA SOLID WASTE AUTHORITY
TASWA DRF
PERMIT AMENDMENT

BME **BIGGS & MATHEWS ENVIRONMENTAL**
 1700 ROBERT ROAD, STE. 100
 MANSFIELD, TEXAS 76063
 817-563-1144

TBPE FIRM NO. F-256
 TBPG FIRM NO. 50222

DRAWING
G4.1

ISSUED FOR PERMITTING PURPOSES ONLY

O:\TASWA\Drawings\ATT\G4.2 Existing GCCS.dwg Layout: G4.1 User: HParker

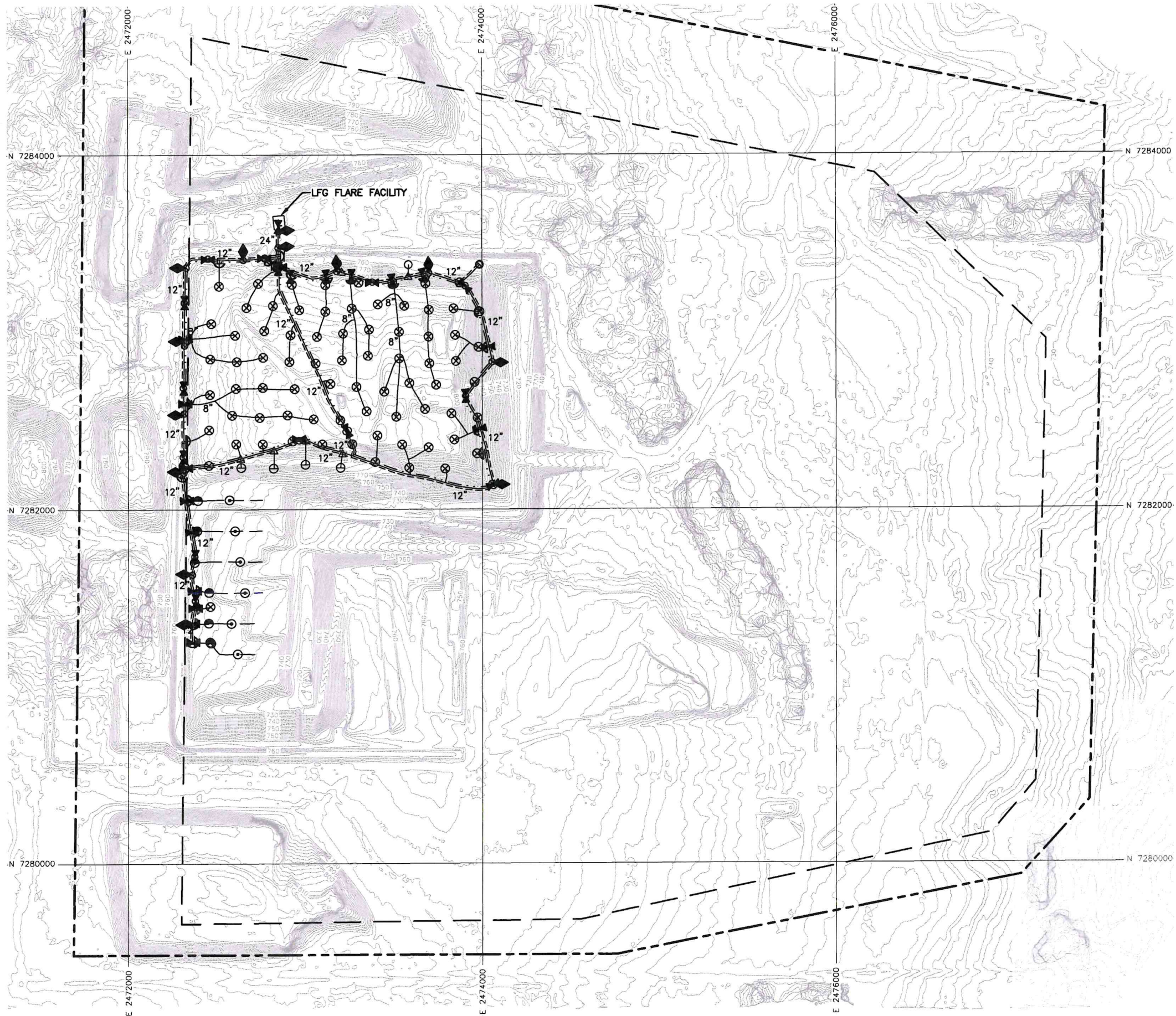

LEGEND

- PERMIT BOUNDARY
- LIMIT OF WASTE
- N 7279000 STATE PLANE COORDINATES
- 750 EXISTING GROUND CONTOUR
- 1000 FINAL COVER CONTOUR
- ⊗ EXISTING LFG EXTRACTION WELL
- ⊖ EXISTING REMOTE LFG EXTRACTION WELL
- EXISTING LEACHATE CLEANOUT RISER CONNECTION
- ⊙ EXISTING HORIZONTAL COLLECTION RISER
- EXISTING LFG COLLECTION PIPING
- EXISTING HORIZONTAL LFG COLLECTOR
- EXISTING AIR SUPPLY LINE
- EXISTING CONDENSATE FORCEMAIN
- ⊙ EXISTING AIR/FORCEMAIN ISOLATION VALVE
- EXISTING AIR/CONDENSATE FORCEMAIN STUB
- ⊗ EXISTING LFG ISOLATION VALVE
- ◆ EXISTING CONDENSATE SUMP
- △ EXISTING REMOTE WELLHEAD
- || EXISTING BLIND FLANGE
- D EXISTING HDPE CAP

NOTES:

1. EXISTING GROUND CONTOURS PROVIDED BY BIGGS AND MATHEWS ENVIRONMENTAL FROM DRONE SURVEY FLOWN ON JUNE 1, 2022.



J. Heath Parker
2/28/2025

EXISTING LANDFILL GAS COLLECTION SYSTEM	
TEXOMA AREA SOLID WASTE AUTHORITY TASWA DRF PERMIT AMENDMENT	
BME	BIGGS & MATHEWS ENVIRONMENTAL 1700 ROBERT ROAD, STE. 100 MANSFIELD, TEXAS 76063 817-563-1144
TBPE FIRM NO. F-256	DRAWING
TBPG FIRM NO. 50222	G4.2

ISSUED FOR PERMITTING PURPOSES ONLY

C:\TASWA\Drawings\ATT G\G4.3-ExtWellDtl.dwg Layout: Layout 1 User: HParker

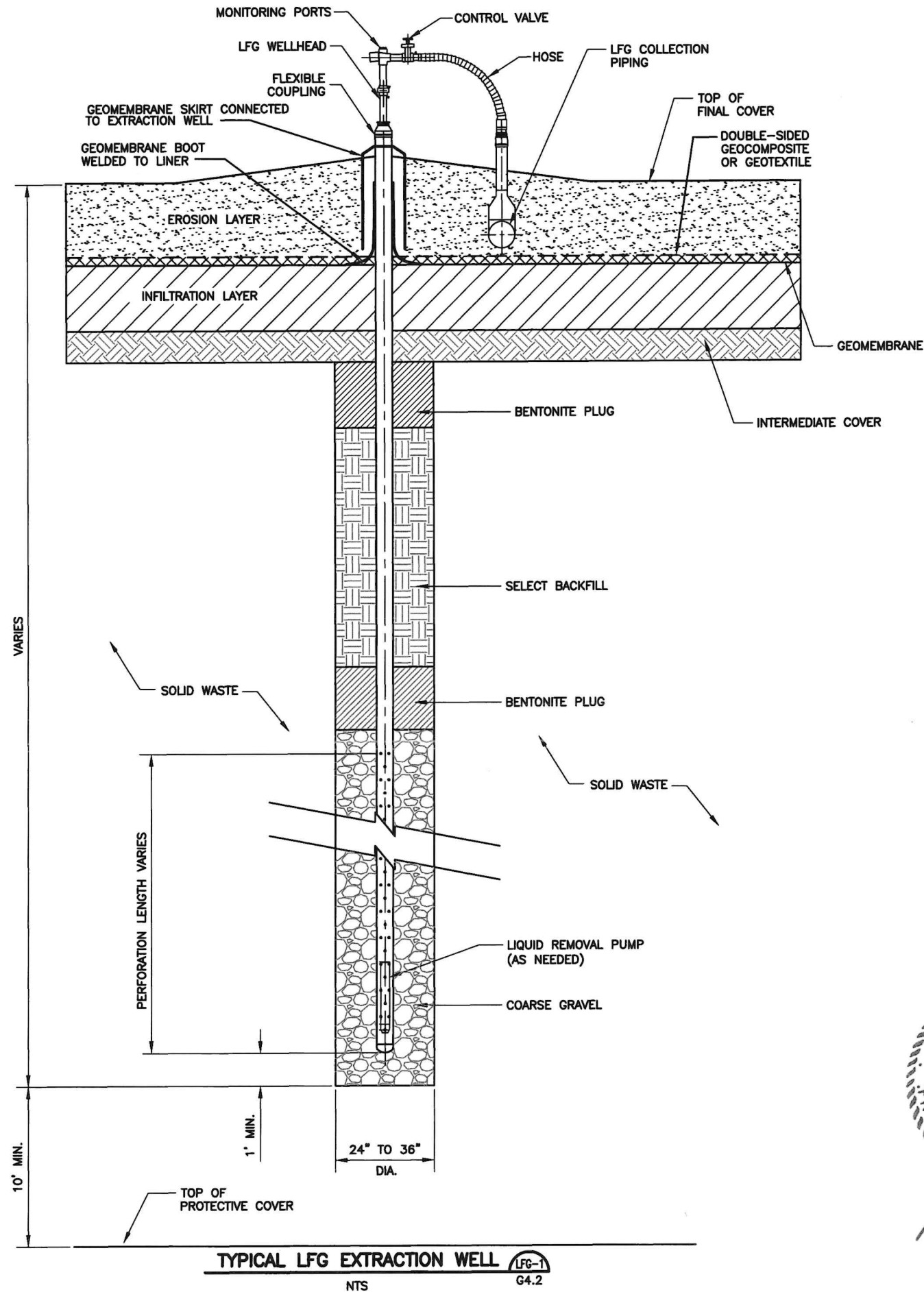

NOTE(S):

1. ALL SIZES AND DIMENSIONS ARE APPROXIMATE.
2. THE EXACT WELLHEAD CONFIGURATION DEPENDS ON MANUFACTURER.
3. ACTUAL LOCATION OF LFG PIPING WILL BE DETERMINED AT TIME OF CONSTRUCTION.
4. THE ELEVATION OF THE EXISTING LINER SYSTEM WILL BE VERIFIED PRIOR TO CONSTRUCTION. THE VERIFICATION PROCESS WILL INCLUDE THE REVIEW OF EXISTING AS-BUILT LINER CERTIFICATION INFORMATION.



J. Heath Parker
2/28/2025

TYPICAL LFG EXTRACTION WELL (LFG-1)
NTS G4.2

ISSUED FOR PERMITTING PURPOSES ONLY

TYPICAL EXTRACTION WELL DETAIL	
TEXOMA AREA SOLID WASTE AUTHORITY TASWA DRF PERMIT AMENDMENT	
BME	BIGGS & MATHEWS ENVIRONMENTAL 1700 ROBERT ROAD, STE. 100 MANSFIELD, TEXAS 76063 817-563-1144
TBPE FIRM NO. F-256	DRAWING G4.3
TBPG FIRM NO. 50222	

**TASWA DISPOSAL AND RECYCLING FACILITY
GRAYSON COUNTY, TEXAS
TCEQ PERMIT APPLICATION NO. MSW 2290A**

PERMIT AMENDMENT APPLICATION

**PART III – FACILITY INVESTIGATION AND DESIGN
ATTACHMENT H
CLOSURE PLAN**

Prepared for

TEXOMA AREA SOLID WASTE AUTHORITY

February 2025
Revised March 2025
Revised June 2025



Biggs & Mathews Environmental, Inc.
Firm Registration No. F-256

Prepared by

BIGGS & MATHEWS ENVIRONMENTAL
1700 Robert Road, Suite 100 ♦ Mansfield, Texas 76063 ♦ 817-563-1144

TEXAS BOARD OF PROFESSIONAL ENGINEERS AND LAND SURVEYORS
FIRM REGISTRATION No. F-256 AND No. 10194895

TEXAS BOARD OF PROFESSIONAL GEOSCIENTISTS
FIRM REGISTRATION No. 50222



Texas Commission on Environmental Quality

Closure Plan for Municipal Solid Waste Type I Landfill Units and Final Facility Closure

This form is for use by applicants or site operators of Municipal Solid Waste (MSW) Type I landfills to detail the plan for closure of a landfill unit, closure of associated storage or processing units, and final closure of the facility to meet the requirements in 30 TAC Chapter 330, §330.63(h) and 30 TAC Chapter 330 Subchapter K for a MSW Type I facility.

If you need assistance in completing this form, please contact the MSW Permits Section in the Waste Permits Division at (512) 239-2335.

I. General Information

Facility Name: TASWA Disposal and Recycling Facility

MSW Permit No.: 2290A

Site Operator/Permittee Name: Texoma Area Solid Waste Authority

II. Landfill and Other Waste Management Units and Operations Requiring Closure at the Facility

A. Facility Units

Table 1. Description of Landfill Units.

Name or Descriptor of Unit	Operating Status of Unit	Type of Liner System Under Unit	Above Grade Class 1 Disposal Cells in this Unit	Below Grade Class 1 Disposal Cells in this Unit	Other Class 1 Disposal Cells in this Unit (describe)	Size of Unit's Waste Footprint (acres)	Maximum Inventory of Waste Ever in Unit (indicate cubic yards or tons)	Other Necessary Information that Pertains to the Unit
TASWA DRF	Active	Standard Subtitle D	<input type="checkbox"/>	<input type="checkbox"/>	<input type="checkbox"/> N/A	475.3	183,500,000 cy	
			<input type="checkbox"/>	<input type="checkbox"/>	<input type="checkbox"/>			
			<input type="checkbox"/>	<input type="checkbox"/>	<input type="checkbox"/>			
			<input type="checkbox"/>	<input type="checkbox"/>	<input type="checkbox"/>			
Totals						475.3	183,500,000 cy	

Closure Plan for Type I Landfill Unit and Facility

Facility Name: TASWA Disposal and Recycling Facility

Revision No.: 0

Permit No: 2290A

Date: March 27, 2025

Table 2. Description of Waste Storage or Processing Units or Operations Associated with this Permit.

Type of Storage or Processing Unit or Operation (individual units may be closed at any time prior to or during the final facility closure as described in this plan)	Operational Status of Unit	Size of the Area Used for the Storage or Processing Unit or Operation (Acres)	Maximum Inventory of Waste Ever in Storage or Processing Unit or Operation (indicate cubic yards or tons)	Other Information (enter other necessary information that pertains to the unit)
			<input type="checkbox"/> cubic yards <input type="checkbox"/> tons	
			<input type="checkbox"/> cubic yards <input type="checkbox"/> tons	
			<input type="checkbox"/> cubic yards <input type="checkbox"/> tons	
			<input type="checkbox"/> cubic yards <input type="checkbox"/> tons	
Totals		enter total size of areas used for storage or processing or operation here	enter total maximum inventory of waste here	

B. Waste Inventory Summary

Table 3. Maximum Inventory of Wastes Ever On Site.

Item	Quantity (indicate cubic yards or tons)
Maximum inventory of waste in landfill units (total from Table 1)	183,500,000 <input checked="" type="checkbox"/> cubic yards or <input type="checkbox"/> tons
Maximum inventory of waste in storage or processing units or operations (total from Table 2)	<input type="checkbox"/> cubic yards or <input type="checkbox"/> tons
Total Maximum Inventory of Wastes ever on site over the active life of the MSW facility (sum of totals from Tables 1 and 2)	183,500,000 <input checked="" type="checkbox"/> cubic yards or <input type="checkbox"/> tons

Closure Plan for Type I Landfill Unit and Facility

Facility Name: TASWA Disposal and Recycling Facility

Revision No.: 0

Permit No: 2290A

Date: March 27, 2025

C. Drawings Showing Details of the Waste Management Units at Closure

Table 4. Location of the Drawings showing Details of the Waste Management Units at Closure (outlines, dimensions, maximum elevations of waste and final cover of landfill units, and waste storage or processing units or operations at closure of the facility).

Drawing Location in the SDP	Drawing Figure Number	Drawing Title	Waste Management Units Details Shown
Part III, Attachment D1	D1.1-D1.4	General Site Plan, Landfill Entrance Facilities, Excavation Plan, Landfill Competition Plan	Property, Permit, and Landfill Footprint boundaries, Easements, Sector boundaries and numbers, Entrance Facilities, Excavation and Final Grading/Completion Plans

III. Description of the Final Cover System Design

A. Types and Descriptions of the Final Cover Systems

Table 5. Types and Descriptions of the Final Cover Systems Permitted or Proposed for Closure of the Landfill Units.

Landfill Unit Name or Descriptor	Type of Final Cover System	Final Cover System Components Description	Other Information (Enter other information as applicable)
TASWA DRF	Standard Subtitle D	Intermediate Cover, 18" Infiltration Layer, 40 mil LLDPE geomembrane, 200 mil Drainage Geocomposite (sideslope) or 8 oz Geotextile (Topslope), and 24" Erosion Layer	

Closure Plan for Type I Landfill Unit and Facility

Facility Name: TASWA Disposal and Recycling Facility

Revision No.: 1

Permit No: 2290A

Date: June 2025

Landfill Unit Name or Descriptor	Type of Final Cover System	Final Cover System Components Description	Other Information (Enter other information as applicable)

B. Design Details

Table 6. Design Details of the Final Cover Top and Side Slopes for the Landfill Units.

Landfill Unit Name or Descriptor	Maximum Final Elevation of Waste (feet above mean sea level [ft-msl])	Maximum Elevation of Top of Final Cover (ft-msl)	Minimum Grade of the Final Cover Top Slope (%)	Maximum Grade of the Final Cover Side Slope (%)	Other Information (enter other information as applicable, e.g. above-grade Class 1 Cell Dikes)
TASWA DRF	1102.2	1106.7	<4	25	

C. Final Cover Drainage Features

Storm water drainage and erosion and sediment control features incorporated on the final cover of the landfill units to protect the integrity and effectiveness of the final cover system include *(please list and describe the drainage features to be installed on the final cover at or prior to closure for each landfill unit, or list the drainage features and provide cross references on the location(s) of the descriptive and details (drawing) information in other parts of the SDP):*

Vegetation, Swales, downchutes, perimeter drainage channel and detention ponds as designed and detailed in Part III, Attachment C3.

Closure Plan for Type I Landfill Unit and Facility

Facility Name: TASWA Disposal and Recycling Facility

Revision No.: 0

Permit No: 2290A

Date: March 27, 2025

D. Final Cover Vegetation or Other Ground Cover Material

The final cover will be seeded and/or sodded with native plants immediately following the application of the final cover in order to minimize erosion. Other materials, including **erosion control matting**, may be incorporated over the final cover soil surface to ensure sufficient coverage of the ground surface to minimize erosion. The estimated percent ground cover to minimize soil loss and maintain long-term erosional stability of the final cover top and side slopes is: **85%**. The minimum material specifications for other ground cover materials are summarized in the table below.

For a landfill with water balance final cover design, the percentage vegetation cover (excluding other ground cover types) will not be less than that assumed in the water balance final cover model.

Table 7. Minimum Specification for Ground Cover Materials Other Than Vegetation, if Applicable.

Other Ground Cover Material	Maximum Particle Size (inches)	Minimum Particle Size (inches)	Material Placement Method	Thickness of Layer (inches)	Percentage Coverage (%)	Other (specify)
N/A						

E. Final Contour Map

Figure **D1.4**, a facility final contour map is attached. The map shows the final contours of the landfill units and the entire facility at closure.

Figures **D2.2-D2.5** and showing the cross-sections of the landfill units at closure are also provided.

The facility final contour and cross-section maps/drawings depict the following information:

- (1) Final constructed contours of the landfill at closure.
- (2) Top slopes and side slopes of the landfill units.
- (3) Surface drainage features.
- (4) 100-year floodplain, as applicable.
- (5) Constructed features providing protection of/from the 100-year floodplain.
- (6) Other (specify):

Closure Plan for Type I Landfill Unit and Facility

Facility Name: TASWA Disposal and Recycling Facility

Revision No.: 0

Permit No: 2290A

Date: March 27, 2025

IV. Description of the Final Cover System Installation Procedure

A. Mode of Installation

Table 8. Mode of Final Cover Installation on the Landfill Units.

Landfill Unit Name or Descriptor	Largest Area of Unit Ever Requiring Final Cover (Acres)	Check this Column if Final Cover will be Placed in Installments as Permitted Elevation is Reached	Check this Column if Final Cover will be Placed when Entire Unit Area Reaches Permitted Elevation	Final Cover Installation Status
TASWA DRF	84	<input checked="" type="checkbox"/>	<input type="checkbox"/>	
		<input type="checkbox"/>	<input type="checkbox"/>	
		<input type="checkbox"/>	<input type="checkbox"/>	
		<input type="checkbox"/>	<input type="checkbox"/>	

B. Installation Drawings for Final Cover and Drainage Features

The following attached plan and cross-section drawings show the final cover design details, the largest area requiring final cover, details of the sequence of installation of the final cover system, and all drainage features.

Table 9. List of Attached Installation Drawings for Final Cover and Drainage Features.

Drawing No.	Drawing Title	Description of Information Contained in Drawing
D1.4	Landfill Completion Plan	Final grades and surface drainage features
D2.1 - D2.5	Cross Section Location Map and Cross Section 1-4	Cross sections of landfill
D3.7	Final Cover Details	Details of final cover system
		(e.g., details of all drainage features on the final cover)
		Other: describe as applicable

Closure Plan for Type I Landfill Unit and Facility

Facility Name: TASWA Disposal and Recycling Facility

Revision No.: 0

Permit No: 2290A

Date: March 27, 2025

C. Final Cover Quality Control Plan

A final cover quality control plan (FCQCP), Attachment **D8**, is attached. The FCQCP describes the final cover system design, construction, and evaluation protocol and processes, including the personnel, materials, methods, sampling and testing standards, procedures, and practices to be used in procuring, handling, installing, and evaluating all elements of the final cover system. It establishes the material requirements; personnel qualifications and roles; installation requirements; quality control and quality assurance monitoring, testing, documentation, and reporting programs to be used during construction of each component of the final cover system to assure and to verify that the final cover system is constructed as designed and in accordance with applicable rules and technical standards.

D. Documentation and Reporting of Final Cover System Construction and Testing

The professional of record will document all aspects and stages of the final cover installation, including materials used, equipment and construction methods, and the type and rate of sampling and quality control testing performed. Following completion of construction of the final cover, the site operator/permittee will submit to the TCEQ executive director, a Final Cover System Evaluation Report (FCSER) for each landfill unit.

V. Closure Activities and Completion Schedules for Each Landfill Unit and for the Final Facility Closure

A. Closure of a Landfill Unit

The following activities will be conducted to satisfy the closure criteria for a landfill unit:

(1) Closure Notification to the TCEQ Executive Director:

The site operator will inform the executive director of the TCEQ, in writing, of the intent to close the unit no later than 45 days prior to the initiation of closure activities and place this notice of intent in the operating record.

(2) Stoppage of Waste Acceptance and Commencement of Other Closure Activities for the Unit:

The site operator will stop accepting waste upon receiving the known final receipt of waste. The site operator will ensure that the permitted top elevations of the in-place waste, as depicted in/derived from the unit's final contour map approved by the TCEQ executive director, are not exceeded at any section or part of the landfill unit. The site operator will begin closure activities for the unit no later than:

- Thirty days after the date on which the unit receives the known final receipt of wastes; or

Closure Plan for Type I Landfill Unit and Facility

Facility Name: TASWA Disposal and Recycling Facility

Revision No.: 0

Permit No: 2290A

Date: March 27, 2025

- One year after the most recent receipt of wastes if the unit has remaining capacity and there is a reasonable likelihood that the unit will receive additional wastes.

(3) Request for Extension Beyond the 1-Year Deadline for Commencing Closure Activities for a Unit:

The site operator may submit a written request to the executive director of the TCEQ for review and approval for an extension beyond the one-year deadline for the initiation of closure. The request will include the following:

- (a) All applicable documentation necessary to demonstrate that the unit has the capacity to receive additional waste; and
- (b) All documentation necessary to demonstrate that the site operator has taken and will continue to take all steps necessary to prevent threats to human health and the environment from the MSW landfill unit.

(4) Construction of Final Cover:

The site operator will construct the permitted final cover over the waste mass utilizing methods, procedures, and specifications described in the FCQCP. The final constructed contours, elevations, and slopes of the installed final cover will match the permitted final cover contours, elevations, and slopes shown in closure drawings contained in this closure plan.

(5) Construction of Drainage Features:

The site operator will construct the drainage structures shown in drawings referenced or contained in this closure plan or in the facility surface water drainage report.

(6) Completion of Outstanding or Replacement of Damaged Groundwater or Landfill Gas Monitoring Components:

The site operator will complete installation of any outstanding or replacement of any damaged groundwater or landfill gas monitoring system components and landfill gas control systems as needed to maintain current and effective groundwater or landfill gas monitoring and control systems.

(7) Submittal of Final Cover System Evaluation Report (FCSER) to the TCEQ Executive Director:

Following completion of construction of the final cover for the subject landfill unit, the site operator will submit to the TCEQ executive director for review and acceptance, a FCSE for the unit.

Closure Plan for Type I Landfill Unit and Facility

Facility Name: TASWA Disposal and Recycling Facility

Revision No.: 0

Permit No: 2290A

Date: March 27, 2025

(8) Completion of Closure Activities for the Landfill Unit:

The site operator will complete closure activities for the unit within 180 days following the start of closure activities, unless the executive director of the TCEQ grants an extension as described in Item V.A.8(a) below.

(a) Request for Extension of the Completion of Closure Activities for the Landfill Unit:

The site operator may submit a written request for an extension for the completion of closure activities to the TCEQ for review and approval. The extension request will include:

- All applicable documentation necessary to demonstrate that closure will, of necessity, take longer than 180 days; and
- All applicable documentation necessary to document that all steps have been taken and will continue to be taken to prevent threats to human health and the environment from the unclosed MSW landfill unit.

(9) Submittal of Engineer's Certification of Closure to the TCEQ Executive Director and Request of Closure Inspection to TCEQ Regional Office:

Following completion of all closure activities for the landfill unit, the site operator will submit:

(a) Closure Inspection

A written request to the local TCEQ regional office for a closure inspection of the unit.

(b) Closure Certification

A certification, signed by an independent licensed professional engineer, to the executive director of the TCEQ for review and approval verifying that closure has been completed in accordance with this closure plan. The site operator will submit the certification via registered mail, and the submittal will contain all applicable documentation necessary for certification of closure of the unit, including:

- A final cover system evaluation report (FCSER) documenting the installation of the final cover. The FCSER may be submitted as a separate document for review and approval following the completion of the final cover installation. In that case, the certification of closure will be submitted subsequently;
- A final contour map as described under Section III.E that includes the relevant unit; and
- Copy of the letter to the TCEQ regional office requesting a closure inspection of the relevant unit.

Closure Plan for Type I Landfill Unit and Facility

Facility Name: TASWA Disposal and Recycling Facility

Revision No.: 0

Permit No: 2290A

Date: March 27, 2025

(10) TCEQ’s Acknowledgement of Termination of Operation and Closure of a Unit:

Upon receipt, the TCEQ executive director will review the closure documents for completeness and accuracy; and following receipt of the closure inspection report from the agency’s regional office verifying proper closure of the MSW landfill unit according to this closure plan, the executive director will, in writing, acknowledge the termination of operation and closure of the unit and deem it properly closed. Thereafter, the site operator will comply with the post-closure care requirements described in the post-closure care plan for the unit.

(11) Deed Recordation for Disposed Regulated Asbestos Containing Materials (RACM):

Upon closure of the unit that accepted RACM, the site operator will place a specific notation that the unit accepted RACM in the deed records for the facility with a diagram identifying the RACM disposal areas. Concurrently, the site operator will submit to the TCEQ executive director, a notice of the deed recordation and a copy of the diagram identifying the asbestos disposal areas.

(12) Placement of all Closure Documentation in the Site Operating Record:

Once approved, the closure certification and all other documentation of closure will be placed in the site operating record.

(13) Closure Schedule for the Landfill Unit:

A closure schedule, Figure N/A, is attached. The schedule shows all the closure activities listed within Section V.A and the timelines for commencing and completing each activity. Also, the schedule shows that closure activities for the landfill unit will be completed within 180 days following the initiation of closure activities as required, unless an extension is granted by the TCEQ executive director.

(14) Other: (enter as applicable).

Closure Plan for Type I Landfill Unit and Facility

Facility Name: TASWA Disposal and Recycling Facility

Revision No.: 0

Permit No: 2290A

Date: March 27, 2025

B. Closure of the Waste Storage or Processing Units or Operations

Closure of the waste storage or processing units or operations authorized under this permit will include removal of all waste, waste residues, and any recovered materials. The facility units and operations will either be dismantled and removed off-site or decontaminated. The site operator will dispose at the landfill or evacuate all materials (including feedstock, in process, and processed) to an authorized facility and disinfect all leachate handling units, tipping areas, processing areas, and post-processing areas. If there is evidence of a release from a unit or operation, the site operator will conduct an investigation, as approved by the TCEQ executive director, into the nature and extent of the release and an assessment of measures necessary to correct an impact to groundwater.

C. Final Closure of the Facility

In addition to the closure activities listed in Section V.A above for closing a landfill unit, the site operator will conduct the following activities for the closure of the entire facility:

(1) Publish Final Closure Notice and Place the closure Plan in a Public Place:

No later than 90 days prior to the initiation of the final facility closure, the site operator will:

(a) Publication of Notice:

The site operator will publish notice in the newspaper(s) of largest circulation in the vicinity of the facility to inform the public of the final closure of the facility. This notice will include:

- The name of the facility;
- The address, and physical location of the facility;
- The facility's permit number; and
- The last date of intended receipt of waste.

(b) Place Copies of the Closure Plan in a Public Place:

The site operator will also make available an adequate number of copies of the approved final closure and post-closure plans for public access and review at the Whitesboro Public Library, 308 W Main St, Whitesboro, TX (state public place within the area, including address, where the plan will be available for public access and review).

(2) Submit Written Notice of "Intent to Close the Facility" to the TCEQ Executive Director:

The site operator will provide written notification to the TCEQ executive director of the intent to close the facility. This notice will be provided to the executive director no later than 90 days prior to the initiation of the final facility closure, and thereafter be placed in the site operating record.

Closure Plan for Type I Landfill Unit and Facility

Facility Name: TASWA Disposal and Recycling Facility

Revision No.: 0

Permit No: 2290A

Date: March 27, 2025

(3) Post Signs and Install Barriers:

Upon notifying the executive director of the intent to close the facility and no later than 90 days prior to the initiation of final facility closure, the site operator will:

(a) Post Final Closure Signs:

The site operator will post a minimum of one sign at the main entrance and all other frequently used points of access for the facility notifying all persons who may utilize the facility of the date of closing for the entire facility and the prohibition against further receipt of waste materials after the stated date.

(b) Install Barriers:

Also, the site/operator will install suitable barriers at all gates or access points to adequately prevent the unauthorized dumping of solid waste at the closed facility.

(4) Filling of "Affidavit to the Public" and Performance of the Final Deed Recording:

Upon closure of all the landfill units or upon final closure of the facility, the site operator will:

(a) File Affidavit

File with the county deed records an "Affidavit to the Public" in a form provided by the TCEQ executive director that includes an updated metes and bounds description of the extent of the disposal areas at the facility and the restrictions to future use of the land in accordance with applicable provisions under 30 TAC Chapter 330, Subchapter T.

(b) Record a Notation on the Deed

Record a certified notation on the deed to the facility property, or on some other instrument that is normally examined during title search, that will in perpetuity notify any potential purchaser of the property that the land has been used as a landfill facility and use of the land is restricted according to the provisions under 30 TAC Chapter 330, Subchapter T.

(c) Place Documents in the Operating Record

Place a copy of the "Affidavit to the Public" and a copy of the modified deed in the site operating record.

Closure Plan for Type I Landfill Unit and Facility

Facility Name: TASWA Disposal and Recycling Facility

Revision No.: 0

Permit No: 2290A

Date: March 27, 2025

(5) Submittal of a Copy of the "Affidavit to the Public" and the "Modified Deed" to the TCEQ Executive Director:

Within ten days after completion of final closure activities of the facility, the site operator will submit the following to the TCEQ executive director by registered mail:

- (a) A certified copy of the "Affidavit to the Public";
- (b) A certified copy of the modified deed to the facility property; and
- (c) A certification, signed by an independent licensed professional engineer, verifying that final facility closure has been completed in accordance with the approved closure plan. The submittal will contain all applicable documentation necessary for certification of final facility closure, including:
 - Final Cover System Evaluation Report (FCSER) documenting the installation of the final cover. The FCSEER may be submitted earlier as a separate document for review and approval following the completion of the final cover installation. In that case, the certification of closure will be submitted subsequently;
 - A final contour map as described under Item III.G above;
 - Copy of a letter to the TCEQ regional office requesting a final closure inspection of the facility; and
 - Copies of documents verifying newspaper publication of the notice of the final facility closure.

(6) Other

Additional items relating to the schedule for final facility closure, and additional closure activities specific to the final closure of this facility include:

N/A

Closure Plan for Type I Landfill Unit and Facility

Facility Name: TASWA Disposal and Recycling Facility

Revision No.: 0

Permit No: 2290A

Date: March 27, 2025

(7) TCEQ's Acceptance of Termination of Operation and Closure of a Landfill Facility:

Following the TCEQ executive director's receipt and completion of the review of the professional engineer's certification of the completion of facility closure and the final closure documents, and receipt of the inspection report from the agency's regional office verifying proper closure of the facility according to this closure plan, the executive director will, in writing, accept the termination of operation and closure of the facility and deem it properly closed. Thereafter, the site operator will comply with the post closure care requirements described in the post closure plan for the facility.

(8) Final Closure Schedule for the Facility:

The attached Figure N/A, Final Closure Schedule, provides the closure schedule for the final facility closure. It incorporates the schedule for closure of a unit as discussed in Section V.A and also shows the commencement and completion timelines for the final closure activities listed within this Section.

VI. Summary of Attachments

A. Drawings and Maps

The following Drawings and Maps are attached as part of this plan.

- Figure D1.4, Final Contour Map.
- Figures D2.2-D2.5, Cross-Section Drawings of the Landfill Units at Closure.
- Figures D3.7, Final Cover and Drainage Features Installation Drawings.
- Other Drawings/Maps: Figures

B. Documents

- Attachment D8, Final Cover Quality Control Plan (FCQCP).
- Attachment N/A, Landfill Unit Closure Schedule Chart.
- Attachment N/A, Final Closure Schedule Chart.
- Other: Attachment

C. Additional Items Attached (enter as applicable)

Closure Plan for Type I Landfill Unit and Facility

Facility Name: TASWA Disposal and Recycling Facility

Revision No.: 1

Permit No: 2290A

Date: June 2025

VII. Professional Engineer's Statement, Seal, and Signature

Name: David Clark, PE

Title: Engineer

Date: 6/16/25

Company Name: Biggs and Mathews Environmental

Firm Registration Number: F-256

Professional Engineer's Seal



Biggs & Mathews Environmental, Inc.
Firm Registration No. F-256

Signature

**TASWA DISPOSAL AND RECYCLING FACILITY
GRAYSON COUNTY, TEXAS
TCEQ PERMIT APPLICATION NO. MSW 2290A**

PERMIT AMENDMENT APPLICATION

PART III – FACILITY INVESTIGATION AND DESIGN

**ATTACHMENT I
POSTCLOSURE PLAN**

Prepared for

TEXOMA AREA SOLID WASTE AUTHORITY

February 2025
Revised March 2025
Revised August 2025



Biggs & Mathews Environmental, Inc.
Firm Registration No. F-256

Prepared by

BIGGS & MATHEWS ENVIRONMENTAL
1700 Robert Road, Suite 100 ♦ Mansfield, Texas 76063 ♦ 817-563-1144

TEXAS BOARD OF PROFESSIONAL ENGINEERS AND LAND SURVEYORS
FIRM REGISTRATION No. F-256 AND No. 10194895

TEXAS BOARD OF PROFESSIONAL GEOSCIENTISTS
FIRM REGISTRATION No. 50222



Texas Commission on Environmental Quality
**Post-Closure Care Plan for Municipal Solid
Waste Type I Landfill Units and Facilities**

This form is for use by applicants or site operators of Municipal Solid Waste (MSW) Type I landfills to provide landfill unit or final facility post-closure care closure plans to meet the requirements in 30 TAC Chapter 330, §330.63(h) and as set out under 30 TAC Chapter 330 Subchapter K for a MSW Type I facility.

If you need assistance in completing this form, please contact the MSW Permits Section in the Waste Permits Division at (512) 239-2335.

I. General Information

Facility Name: TASWA Disposal and Recycling Facility

MSW Permit No.: 2290A

Site Operator/Permittee Name: Texoma Area Solid Waste Authority

II. Party Responsible for Overseeing and Conducting Post Closure Care Activities

Name (Person or Office Responsible): Texoma Area Solid Waste Authority

Position or Title: Executive Director

Mailing Address: 25090 State Highway 56

City: Whitesboro

State: Texas

Zip Code: 76273

Telephone Number: (903) 564-4749

Post-Closure Care Plan for Type I Landfill Units and Facility

Facility Name: TASWA Disposal and Recycling Facility

Revision No.:

0

Permit No: 2290A

Date:

March 27, 2025

III. Post-Closure Care Status of Landfill Units at the Facility

Check the applicable box for the post-closure care status of the units at the facility and complete the applicable tables as indicated:

- A. No landfill unit is in post-closure care in this facility at the time this application is submitted (skip Table 1 and complete Table 2 below if you check this item)
- B. This facility includes landfill units currently in post-closure care and landfill units that are not yet in post-closure care (complete Tables 1 and 2 below if you check this item).
- C. This facility contains only landfill units currently in post-closure care (complete Table 1 below if you check this item; do not complete Table 2).

Table 1: Landfill Units Currently in Post-Closure Care

Landfill Unit Name	Drawing Number Showing the Landfill Unit	Date TCEQ Acknowledged Closure of Unit	Date Post-Closure Care Commenced	Projected Date of End of Post-Closure Care

Table 2: Landfill Units Not yet in Post-Closure Care

Category of Landfill Unit (Regarding Status of Waste Receipt)	Landfill Unit Names or Descriptors	Site Development Plan Drawing Titles and Numbers Showing the Units
Stopped Receiving Waste Prior to October 9, 1993		
Received Waste on or after October 9, 1993	TASWA DRF	Part III Attachment D1, General Site Plan

Post-Closure Care Plan for Type I Landfill Units and Facility

Facility Name: TASWA Disposal and Recycling Facility

Revision No.:

0

Permit No: 2290A

Date:

March 27, 2025

Category of Landfill Unit (Regarding Status of Waste Receipt)	Landfill Unit Names or Descriptors	Site Development Plan Drawing Titles and Numbers Showing the Units
Proposed to be Constructed		
Other (enter as applicable)		

IV. Post-Closure Care Maintenance Requirements and Activities to be Conducted

A. Categories of Landfill Units and Applicable Post-Closure Care Maintenance Requirements and Activities

Check the appropriate boxes to indicate the categories of landfill units at the facility and complete the applicable section of the post-closure care maintenance requirements and activities below.

This facility includes landfill units that:

- Stopped receiving waste prior to October 9, 1993

If you check this item, complete the post-closure care maintenance requirements and activities specified in Subsection IV.B below. Skip Subsection IV.B if this item does not apply to your facility.

- Received waste on or after October 9, 1993

If you check this item, complete the post-closure care maintenance requirements and activities specified in Subsection IV.C below. Skip Subsection IV.C if this item does not apply to your facility.

- Are proposed to be constructed

If you check this item, complete the post-closure care maintenance requirements and activities specified in Subsection IV.C below. Skip Subsection IV.B, unless your facility also contains units that stopped receiving waste prior to October 9, 1993.

Post-Closure Care Plan for Type I Landfill Units and Facility

Facility Name: TASWA Disposal and Recycling Facility

Revision No.:

1

Permit No: 2290A

Date:

August 13, 2025

B. Post-Closure Care Maintenance Requirements and Activities for the Landfill Units that Stopped Receiving Waste Prior to October 9, 1993

The site operator will commence and conduct post-closure care maintenance of the units that stopped receiving waste prior to October 9, 1993 for a minimum of the first **five years** following commencement of post-closure care as specified below and in accordance with applicable rules under 30 TAC §330.463(a). Post-closure care maintenance will start on the date the professional engineer’s certification of the completion of closure is accepted in writing by the TCEQ executive director and the site operator will carry out the following activities and operations during the period.

1. Maintenance of Right of Entry and Rights of Way

The site operator will retain the right of entry to and maintain all rights-of-way of the closed units in order to conduct periodic inspections of the units throughout the post-closure care period. TCEQ staff will have access to the site to conduct inspection or investigation that may be necessary during the period.

2. Inspection Activities and Correction of Problems

The site operator will conduct inspection of the closed landfill units at the frequencies indicated in Table 3 below, utilizing the inspection protocol maintained in the site operating record, and will correct all identified problems as needed.

Table 3: Inspection Activities Schedule

Post-Closure Care Inspection Item	Frequency of Inspection	Types of Deficiency Conditions to be looked for during Inspection
Final Cover Condition	Semi-annual	See Table 5
Vegetation	Semi-annual	See Table 5
Leachate Management Systems	Semi-annual	See Table 5

Post-Closure Care Plan for Type I Landfill Units and Facility

Facility Name: TASWA Disposal and Recycling Facility

Revision No.:

1

Permit No: 2290A

Date:

August 13, 2025

Post-Closure Care Inspection Item	Frequency of Inspection	Types of Deficiency Conditions to be looked for during Inspection
Landfill Gas Monitoring and Control Systems	Quarterly	See Table 10
Groundwater Monitoring Systems	Semi-annual	See Table 9
Drainage Structures	Semi-annual	See Table 6
Ponding of Water	Semi-annual	See Table 5
Other:		

3. Continuation of Monitoring Programs during Post-Closure Care Period

The site operator will continue the monitoring programs listed in Table 4 during the post-closure care period. The monitoring programs will be conducted as specified in the applicable section of the facility’s Site Development Plan and applicable rules.

Table 4: Monitoring and Reporting Schedule

Monitoring Program	Frequency of Monitoring	Frequency of Reporting of Results
Groundwater monitoring	Semi-annual	Semi-annual
Landfill gas monitoring	Quarterly	Quarterly
Other:		

Post-Closure Care Plan for Type I Landfill Units and Facility

Facility Name: TASWA Disposal and Recycling Facility

Revision No.:

0

Permit No: 2290A

Date:

March 27, 2025

4. Detection of a Release, Nature and Extent Investigation, and Corrective Action to Address Release from the MSW Unit

Upon detection of any evidence of a release from the landfill or other associated waste management units at the facility, the site operator will:

- Notify the executive director of the TCEQ of the condition detected;
- Investigate, if so directed by the executive director of the TCEQ, whether a release from the landfill or other associated waste management units at the facility has occurred;
- Investigate the nature and extent of the release, if a release is confirmed;
- Assess measures necessary to correct any impact to groundwater;
- Submit a corrective action plan via a permit modification for TCEQ executive director's review and approval; and
- Conduct corrective action as approved by the TCEQ executive director.

5. Extension of Post-Closure Care Period

If any of the problems listed in Table 3 occurs, or corrective action as indicated in Subsection IV.B.4 above continues, after the end of the five-year post-closure care period or persists for longer than the first five years of post-closure care, the site operator will be responsible for their correction and will continue to conduct post-closure care maintenance until the TCEQ executive director determines that all problems have been adequately resolved.

6. Reduction of Post-Closure Care Period

The site operator may request in writing for the TCEQ executive director to reduce the post-closure care period for the units if all wastes and waste residues have been removed during closure and any new or on-going corrective action to address confirmed releases from the landfill have been completed as acknowledged in writing by the executive director.

Post-Closure Care Plan for Type I Landfill Units and Facility

Facility Name: TASWA Disposal and Recycling Facility

Revision No.:

0

Permit No: 2290A

Date:

March 27, 2025

C. **Post-Closure Care Requirements and Activities for Municipal Solid Waste Landfill Units that Receive Waste on or after October 9, 1993 and for New Units**

The site operator will commence and conduct post-closure care maintenance of the units that receive waste on or after October 9, 1993 and new units constructed under this permit as follows and in accordance with applicable rules under 30 TAC §330.463.

1. Commencement of Post-Closure Care

Post-closure care maintenance will start on the date the professional engineer's certification of the completion of closure is accepted in writing by the TCEQ executive director and the site operator will carry out the following activities and operations during the period.

2. Period of Post-Closure Care

The site operator will conduct post-closure care for the landfill units for a period of **30 years**, unless this time period is increased or reduced by the executive director as discussed in Subsection IV.C.11.

3. Maintenance of Right of Entry and Rights of Way

The site operator will retain the right of entry to the closed units and the facility and will maintain all rights-of-way of the closed units in order to conduct periodic inspection and maintenance of the closed units until the end of the post-closure care period.

4. Inspection Activities

The site operator will conduct periodic inspection of the closed units to identify and document deficiency conditions and conduct maintenance and corrective action to maintain compliance. Sections IV.C. 8.(a)-(c) provide information on the inspection items and deficiency conditions that the site operator will look for during inspection of the major components of the landfill and the site during the post-closure care period. Other inspection and maintenance provisions that apply during the post-closure care period as specified in the facility's site operating plan, site development plan, or applicable rules will remain in effect.

Post-Closure Care Plan for Type I Landfill Units and Facility

Facility Name: TASWA Disposal and Recycling Facility

Revision No.:

0

Permit No: 2290A

Date:

March 27, 2025

5. Documentation of Inspection

The site operator will document and maintain records of the post-closure care inspections in the site operating record. The records will include:

- The date of inspection;
- Components and items inspected;
- Problems detected or observed; and
- The name of the personnel who conducted the inspection.

6. Corrective Actions

Based on the results of the inspection activities, the site operator will conduct needed restoration and remediation actions on the closed unit no later than the next scheduled inspection event. Also, the site operator will conduct maintenance action on regular periodic schedule in order to:

- Maintain the integrity and effectiveness of all final cover, facility vegetation, and drainage control systems;
- Correct any effects of settlement, subsidence, ponded water, erosion, or other events or failures detrimental to the integrity of the closed unit; and
- Prevent any surface run-on and run-off from eroding or otherwise damaging the final cover system during the post-closure care period.

7. Documentation of Corrective Actions

The site operator will document and maintain, in the facility's site operating record, records of the restoration, remediation, and maintenance activities performed, including the date of completion of the activities.

8. Inspection Activities Schedules

(a) Final Cover Inspection

Inspection Frequency: Annual

Other Inspection Occasions/Events:

Post-Closure Care Plan for Type I Landfill Units and Facility

Facility Name: TASWA Disposal and Recycling Facility

Revision No.:

0

Permit No: 2290A

Date:

March 27, 2025

Table 5: Final Cover Inspection Items

Inspection Item	Types of Deficiency Conditions to be looked for during Inspection
Vegetation and other Ground Cover Materials	Coverage
Settlement	Lack of drainage
Subsidence	Lack of drainage
Ponded Water	Lack of drainage
Erosion	Excess soil loss
Other (enter other events or failures detrimental to the integrity and effectiveness of the final cover):	
Other (enter other events or failures detrimental to the integrity and effectiveness of the final cover):	

Post-Closure Care Plan for Type I Landfill Units and Facility

Facility Name: TASWA Disposal and Recycling Facility

Revision No.:

0

Permit No: 2290A

Date:

March 27, 2025

(b) Drainage Control System Inspection

Inspection Frequency: Annual

Other Inspection Occasions/Events:

Table 6: Drainage Control System Inspection Items

Inspection Item	Types of Deficiency Conditions to be looked for during Inspection
Vegetation within Drainage Control Structures	Lack of drainage
Component Failures	Lack of drainage
Wash Outs	Lack of drainage
Sediment Build Up	Lack of drainage
Other (enter other events or failures detrimental to the integrity and effectiveness of drainage structures):	

Post-Closure Care Plan for Type I Landfill Units and Facility

Facility Name: TASWA Disposal and Recycling Facility

Revision No.:

0

Permit No: 2290A

Date:

March 27, 2025

(c) Access and Rights-of-Way

Inspection Frequency: Annual

Other Inspection Occasions/Events:

Table 7: Access and Rights of Way Inspection Items

Inspection Item	Types of Deficiency Conditions to be looked for During Inspection
Gates, Gate Locks and Barriers	Security
Fence and other Access Control Barriers	Security
Vegetation Control in Areas of the Facility other than the Final Cover	Access
Other (enter other access control and rights-of-way inspection items):	

9. Continuation of Operation and Maintenance of the Leachate Collection and Removal Systems (LCRS)

The site operator will continue the operation and maintenance of the LCRS and disposal of leachate during the post-closure care period in accordance with the facility’s leachate management plan found in Attachment/Appendix/Section D6 of the Site Development Plan and consistent with applicable provisions under 30 TAC Sections 330.331 and 330.333.

(a) Performance Monitoring and Inspection of the LCRS

During the post-closure care period, the site operator will monitor the performance of the LCRS on a annual basis to assure continuous compliance with the design criteria and inspect the LCRS components on a annual basis, at a minimum, to determine the need for repair or maintenance. Inspection and monitoring will follow the procedure described in the facility’s leachate management plan found in

Post-Closure Care Plan for Type I Landfill Units and Facility

Facility Name: TASWA Disposal and Recycling Facility

Revision No.:

0

Permit No: 2290A

Date:

March 27, 2025

Attachment/Appendix/Section D6 of the Site Development Plan or in the written inspection protocol maintained in the facility's site operating record. Results of the monitoring and inspection activities will be documented in the site operating record. The items and components of the leachate collection and removal system to be inspected will include but are not limited to the items in Table 8 below.

Table 8: Leachate Collection and Removal System Inspection

Inspection Item/Component	Types of Deficiency Conditions to be looked for during Inspection
Leachate Collection System	Operational

(b) LCR Maintenance and Repairs

During the post-closure care period, the site operator will perform routine and needed maintenance or repairs of the LCRS items and components based on the monitoring and inspection results. Maintenance and repair will be completed prior to the next scheduled monitoring event and documented within the site operating record.

(c) Discontinuation of Leachate Management

The site operator may submit data and information from the closed units to the TCEQ executive director to demonstrate that leachate no longer poses a threat to human health and the environment. Upon the executive director's approval of the demonstration, the site operator will be allowed to stop managing leachate at the closed unit.

Post-Closure Care Plan for Type I Landfill Units and Facility

Facility Name: TASWA Disposal and Recycling Facility

Revision No.:

0

Permit No: 2290A

Date:

March 27, 2025

10. Continuation of Monitoring Systems Operation and Maintenance:

The site operator will continue to conduct monitoring systems operation and maintenance activities to ensure the integrity of the containment system and to promptly detect and control releases to the environment during the post-closure care period as follows.

(a) Groundwater Monitoring System

The site operator will continue groundwater monitoring activities (including sampling, analysis, reporting, etc.) in accordance with the approved site-specific Groundwater Sampling and Analysis Plan (GWSAP) found in Attachment F, Appendix F2 of the Site Development Plan, the Groundwater Monitoring System Design found in Attachment F, Appendix F1 of the Site Development Plan and consistent with the provisions under 30 TAC Chapter 330 Subchapter J. Groundwater monitoring will be conducted semiannually or as otherwise approved by the TCEQ executive director during the post-closure care period.

i. Inspection of the Groundwater Monitoring System

During each groundwater monitoring event, the site operator will perform inspection of all the groundwater monitoring wells that are part of the groundwater monitoring system and other items discussed in the GWSAP or the Groundwater Monitoring System Design. The items and components of the groundwater monitoring system to be inspected are included in Table 9:

Table 9: Groundwater Monitoring Systems Inspection

Inspection Item/Component	Types of Deficiency Conditions to be looked for during Inspection
Groundwater Monitoring System	Operational

Post-Closure Care Plan for Type I Landfill Units and Facility

Facility Name: TASWA Disposal and Recycling Facility

Revision No.:

0

Permit No: 2290A

Date:

March 27, 2025

Inspection Item/Component	Types of Deficiency Conditions to be looked for during Inspection

ii. Maintenance and Repair of the Groundwater Monitoring System

The site operator will perform needed maintenance and/or repairs of the groundwater monitoring system items and components based on the inspection results. Maintenance and/or repairs will be performed no later than the next scheduled monitoring event.

iii. Documentation of Inspection, Maintenance, and Repairs

The site operator will document and discuss the results of the groundwater monitoring system inspection, maintenance, and repair activities in the groundwater monitoring report submitted to the TCEQ executive director, and maintain the documents in the site operating record.

(b) Landfill Gas Management System

During the post-closure care, the site operator will continue landfill gas monitoring operations and activities, documentation, and reporting in accordance with the facility’s landfill gas management plan and consistent with the requirements under 30 TAC Chapter 330, Subchapter I.

i. LFG Monitoring and Monitoring System Inspection

All structures and perimeter gas monitoring probes will be sampled quarterly or more frequently as approved by the TCEQ executive director. The site operator will conduct routine inspections of the landfill gas management system components as provided in the landfill gas management plan during the

Post-Closure Care Plan for Type I Landfill Units and Facility

Facility Name: TASWA Disposal and Recycling Facility

Revision No.:

0

Permit No: 2290A

Date:

March 27, 2025

post-closure care period. The items and components to be inspected are included in Table 10.

Post-Closure Care Plan for Type I Landfill Units and Facility

Facility Name: TASWA Disposal and Recycling Facility

Revision No.:

0

Permit No: 2290A

Date:

March 27, 2025

Table 10: Landfill Gas Management System Inspection

Inspection Item/Component	Types of Deficiency Conditions to be looked for during Inspection
Landfill Gas Management/ Monitoring System	Operational

ii. LFG Management System Maintenance

The site operator will perform routine and needed maintenance of the landfill gas management system including calibration of the monitoring equipment. Needed maintenance and/or repair work will be performed based on the inspection and monitoring results no later than the next scheduled monitoring event.

(c) Continuation of Earth Electrical Resistivity Survey

The site operator will, if applicable, continue earth electrical resistivity surveys as applicable at the frequency stated in the approved site development plan or as otherwise approved by the TCEQ executive director.

11. Detection of a Release, Nature and Extent Investigation, and Corrective Action to Address Release from the MSW Unit

If there is evidence of a release from the landfill or other associated waste management units at the facility, the site operator will:

- Notify the executive director of the TCEQ of the condition detected;
- Investigate, if so directed by the executive director of the TCEQ, whether a release from the landfill or other associated waste management units at the facility has occurred;

Post-Closure Care Plan for Type I Landfill Units and Facility

Facility Name: TASWA Disposal and Recycling Facility

Revision No.:

0

Permit No: 2290A

Date:

March 27, 2025

- Investigate the nature and extent of the release, if a release is confirmed;
- Assess measures necessary to correct any impact to groundwater;
- Submit a corrective action plan via a permit modification for TCEQ executive director's review and approval; and
- Conduct corrective action as approved by the TCEQ executive director.

12. Revision of the Length of Post-Closure Care Period

(a) The Post-Closure Care Period May Be Decreased

The length of the post-closure care period may be decreased by the TCEQ executive director if the site operator submits a documented certification signed by a licensed professional engineer and including all applicable supporting documentation that demonstrates that the reduced period is sufficient to protect human health and the environment, and the executive director approves the decrease in writing after review.

(b) The Post-Closure Care Period May be Increased

The length of the post-closure care period may be increased by the TCEQ executive director if it is determined that the longer period is necessary to protect human health and the environment.

V. Recordkeeping

The site operator will place a copy of this post-closure plan in the facility's site operating record by the initial receipt of waste at the units proposed at the time of this application. Also, the site operator will document and maintain records of all inspection, monitoring, maintenance, repair, or remediation activities, and detail the results of any inspection and schedules of any other actions to be taken to maintain compliance, in the site operating record.

VI. Planned Use of the Land during and after the Post-Closure Care Period

Post-closure use of the property will not disturb the final cover, liners, or other containment or monitoring systems unless such disturbance is necessary for the proposed

Post-Closure Care Plan for Type I Landfill Units and Facility

Facility Name: TASWA Disposal and Recycling Facility

Revision No.:

0

Permit No: 2290A

Date:

March 27, 2025

use or to protect human health and the environment and is authorized by the TCEQ executive director consistent with provisions under 30 TAC Chapter 330 Subchapter T.

Description of the Planned Use of the Land during or after the Post-Closure Care Period (*describe the planned use of the land during or after the post-closure care period; if not known at this time, enter "NOT KNOWN"*):

Not known

VII. Post-Closure Care and Corrective Action Cost Estimates

A detailed written cost estimate in current dollars for conducting post closure care is provided in (*enter location of the post-closure care cost estimate in the application/permit document*):

Attachment J

The cost estimate for corrective action will be provided as needed, via a permit modification, during the life and/or post-closure care period of the unit or facility.

VIII. Certification of Completion of Post-Closure Care

Upon completion of the post-closure care maintenance period for each municipal solid waste landfill unit, the site operator will submit to the TCEQ executive director for review and approval a certification, signed by an independent licensed professional engineer, verifying that post-closure care has been completed in accordance with the approved post-closure plan. The submittal to the executive director shall include all applicable documentation necessary for the certification of completion of post-closure care. These will include information relating to the condition and status of:

- The final cover integrity and stability, including the condition of the soil, vegetation, drainage structures, etc.
- Groundwater quality at the site, as determined from on-going groundwater detection or assessment monitoring or corrective measures data during the period.
- Landfill gas (methane) migration, as determined from on-going landfill gas monitoring and remediation data during the period.
- Leachate generation rate and quantity as determined from on-going leachate management data over the period.

Post-Closure Care Plan for Type I Landfill Units and Facility

Facility Name: TASWA Disposal and Recycling Facility

Revision No.:

0

Permit No: 2290A

Date:

March 27, 2025

- The surface water management system.
- Access control structures.

The engineer’s certification of post-closure will show that, based on a summary of monitoring and inspection results, the final cover system continues to maintain its integrity, stability, and function; groundwater remains uncontaminated and monitoring is no longer required; landfill gas is not migrating beyond the facility boundary or accumulating in structures at action levels and monitoring is no longer required; leachate generation rate and quantity will not result in greater than 12 inches of head above the liner, no breakouts have occurred, and all slopes remain as approved and leachate management is no longer required; the surface water management system continues to function as designed; and the access control structures remain intact.

Documentation supporting the professional engineer’s certification will be furnished to the TCEQ executive director upon request and will be maintained in the site operating record until the executive director acknowledges termination of post-closure in writing.

IX. Voluntary Revocation Request

Upon completion of the post-closure care period for the final unit at the facility, the site operator will submit to the executive director a request for voluntary revocation of the facility permit.

X. Attachments

The following figures and documents are attached as part of this post-closure care plan:

Post-Closure Care Plan for Type I Landfill Units and Facility

Facility Name: TASWA Disposal and Recycling Facility

Revision No.:

1

Permit No: 2290A

Date:

August 13, 2025

XI. Engineer's Seal and Signature

Name: David Clark, PE Title: Engineer

Date: 3/27/25

Company Name: Biggs and Mathews Environmental Firm Registration Number: F-256

Professional Engineer's Seal

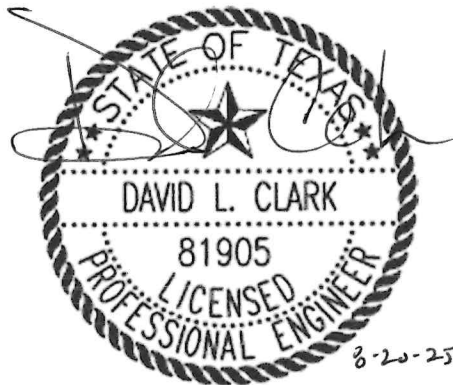

Biggs & Mathews Environmental, Inc.
Firm Registration No. F-256

Signature

**TASWA DISPOSAL AND RECYCLING FACILITY
GRAYSON COUNTY, TEXAS
TCEQ PERMIT APPLICATION NO. MSW 2290A**

PERMIT AMENDMENT APPLICATION

PART III – FACILITY INVESTIGATION AND DESIGN

**ATTACHMENT J
COST ESTIMATES FOR CLOSURE AND POSTCLOSURE CARE**

Prepared for

TEXOMA AREA SOLID WASTE AUTHORITY

February 2025
Revised March 2025

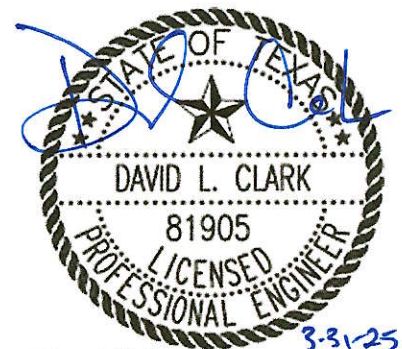

Biggs & Mathews Environmental, Inc.
Firm Registration No. F-256

Prepared by

BIGGS & MATHEWS ENVIRONMENTAL
1700 Robert Road, Suite 100 ♦ Mansfield, Texas 76063 ♦ 817-563-1144

TEXAS BOARD OF PROFESSIONAL ENGINEERS AND LAND SURVEYORS
FIRM REGISTRATION No. F-256 AND No. 10194895

TEXAS BOARD OF PROFESSIONAL GEOSCIENTISTS
FIRM REGISTRATION No. 50222

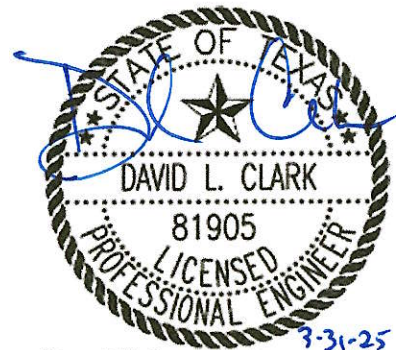

Biggs & Mathews Environmental, Inc.
Firm Registration No. F-256

CONTENTS

CLOSURE COST ESTIMATE FORM (TCEQ - 20721)

POST-CLOSURE CARE COST ESTIMATE FORM (TCEQ – 20723)

DRAWING

J.1 Largest Area Requiring Final Cover

Evidence of Financial Assurance



Texas Commission on Environmental Quality
Closure Cost Estimate Form for Municipal Solid
Waste Type I Landfills

This form is for use by applicants or site operators to provide cost estimates for closure of MSW Type I landfills to meet the requirements in 30 Texas Administrative Code (TAC) Chapter 330, Section 330.63(j) and 30 TAC Chapter 330 Subchapter L. The costs to be provided herein are cost estimates for hiring a third party to close the largest waste fill area that could potentially be open in the year to follow and those areas that have not received final cover. If you need assistance in completing this form, please contact the MSW Permits Section in the Waste Permits Division at (512) 239-2335.

Facility Name: TASWA Disposal and Recycling Facility

MSW Permit No.: 2290A

Site Operator/Permittee Name and Mailing Address: Texoma Area Solid Waste Authority

Total Closure Cost Estimate (2025 Dollar Amount):

I. Professional Engineer's Statement, Seal, and Signature

I am a licensed professional engineer in the State of Texas. To the best of my knowledge, this Closure Cost Estimate has been completed in substantial conformance with the facility Closure Plan and, in my professional opinion, is in compliance with Title 30 of the Texas Administrative Code, Chapter 330.

Name: David Clark

Title: Engineer

Date: 3/27/25

Company Name: Biggs and Mathews Environmental Firm Registration Number: F-256

Professional Engineer's Seal

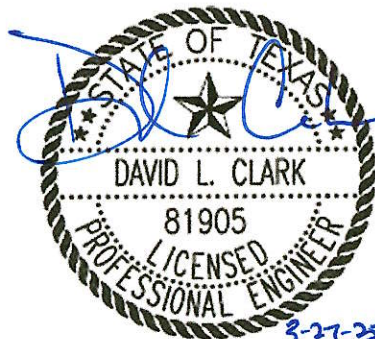

Biggs & Mathews Environmental, Inc.
Firm Registration No. F-256

Professional Engineer's Signature

Closure Cost Estimate for MSW Type I Landfill

Facility Name: TASWA Disposal and Recycling Facility

Revision No.: _____

Permit No: 2290A

Date: 3/28/2025

II. Annual Review of Permit Conditions, Cost Estimates, Inflation Factor, and Financial Assurance

The permittee/site operator acknowledges that he/she will:

- (1) Review the facility's permit conditions on an annual basis and verify that the current active and inactive waste fill areas of the landfill match the areas on which closure cost estimates are based.
- (2) Request in writing via a permit modification application for an increase in the closure cost estimate and the amount of financial assurance provided if changes to the closure plan or the landfill conditions increase the maximum cost of closure at any time during the remaining active life of the landfill.
- (3) Request in writing via a permit modification application for a reduction in the cost estimate and the amount of financial assurance provided if the cost estimate exceeds the maximum cost of closure at any time during the remaining active life of the landfill. The permit modification application will include a description of the situation and a detailed justification for the reduction of the closure cost estimate and the amount of financial assurance.
- (4) Establish financial assurance for closure of the unit in an amount no less than the current closure cost estimate in accordance with 30 TAC Chapter 37, Subchapter R.
- (5) Adjust the current cost estimate for inflation within 60 days prior to the anniversary date of the first establishment of the financial assurance mechanism.
- (6) Provide annual inflation adjustments to the closure costs and financial assurance during the active life of the facility, until the facility is officially placed under the post closure care period and all requirements of the final closure plan have been approved in writing by the TCEQ executive director. The adjustment will be made using an inflation factor derived from the most recent annual Implicit Price Deflator for Gross National Product published by the United States Department of Commerce in its Survey of Current Business, as specified in paragraphs (1) and (2) of 30 TAC §37.131. The inflation factor is the result of dividing the latest published annual Deflator by the Deflator for the previous year.
- (7) Provide continuous financial assurance coverage for closure until the facility is officially placed under the post-closure care period.

Closure Cost Estimate for MSW Type I Landfill

Facility Name: TASWA Disposal and Recycling Facility

Revision No.: _____

Permit No: 2290A

Date: 3/28/2025

III. Description of the Closure Cost Estimates Worksheet

The following descriptions of the items on the closure cost estimates worksheet provide guidance for identifying the minimum work or cost elements and estimating the unit or lump sum cost of each item as applicable. Enter additional detail for each item in the field following the item as necessary and as site-specific condition warrants. The cost items are grouped under closure costs for engineering, construction, and storage and processing units. Include attachments to detail any additional work and associated costs necessary to close the site that is not already included as a line item on the worksheet. Reference the attachments and list the work or cost items in the fields under "Additional Engineering Cost Items Not Listed on the Worksheet," "Additional Construction Cost Items Not Listed on the Worksheet," or "Additional Storage and Processing Units Items Not Listed on the Worksheet" as applicable. Provide the total cost of the additional work or cost items in each cost category on the worksheet line that precedes the cost subtotal for each cost group.

1. Engineering Costs

The engineering tasks have been subdivided into seven items and are described below. Other related costs may be added as site-specific issues warrant.

1.1. Topographic Survey

A topographic survey will be required to verify the existing elevation and slopes of the landfill to ensure conformance with the final cover system, drainage system, and final grading designs.

Enter additional topographic survey work or cost element details as site-specific conditions warrant:

1.2. Boundary Survey

The metes and bounds description is required for filing of the affidavit of closure and deed recording of any area of the site which has received waste. Other activities to be included here are publication of the public notice of closing activities.

Enter additional boundary survey work or cost element details as site-specific conditions warrant:

1.3. Site Evaluation

The evaluation includes a site inspection to identify waste disposal areas, analyze drainage and erosion protection needs, and to determine other site operational features that are not in compliance with the permit. The site evaluation also includes verifying the need for new or relocation of existing groundwater monitoring wells and landfill gas monitoring probes, analysis of groundwater samples, and review of site operating record. The third party consultant who performed the site evaluation will prepare and submit an engineering report to the executive director to document the status of the site.

Closure Cost Estimate for MSW Type I Landfill

Facility Name: TASWA Disposal and Recycling Facility

Revision No.: _____

Permit No: 2290A

Date: 3/28/2025

The report will identify all areas of work and the associated implementation costs necessary to safely close the landfill operations with recommendations on how to fulfill these needs.

Enter additional site evaluation work or cost element details as site-specific conditions warrant:

1.4. Development of Plans

The final closure, plan the final cover system design and specifications, grading and drainage plans, specification for revegetation, design of any other improvements to bring the site into compliance with the permit, the closure schedule, and coordination with the TCEQ and provision of closure notice to the public.

Enter additional development of plans work or cost element details as site-specific conditions warrant:

1.5. Contract Administration (bidding and award)

The third-party consultant will advertise the project, receive the bids, evaluate the bids, award the closure construction contract and administer the contract during construction.

Enter additional contract administration work or cost element details as site-specific conditions warrant:

1.6. Closure Inspection and Testing

The professional of record will observe closure construction, perform cover thickness and permeability verification, and prepare an evaluation report upon completion of closure.

Enter additional closure inspection or testing work or cost element details as site-specific conditions warrant:

1.7. TPDES and other Permits

The third-party consultant will prepare plans, specifications, and other documents necessary for compliance with applicable federal and state laws and requirements, including the Clean Water Act, for the proper closure of the site.

Enter additional TPES or other permits work or cost element details as site-specific conditions warrant:

1.8. Additional Engineering Cost Items Not Listed on the Worksheet

List the Attachment(s) detailing any additional engineering cost items necessary to close the site that is not already included as a line item on the worksheet:

N/A Also, reference these Attachments in the "Units" column on this line of the

Closure Cost Estimate for MSW Type I Landfill

Facility Name: TASWA Disposal and Recycling Facility

Revision No.: _____

Permit No: 2290A

Date: 3/28/2025

worksheet. Provide the total cost of all additional engineering cost items in the "Cost" column.

1.9. Engineering Costs Subtotal

1.9.1. Enter the sum of engineering costs in Items 1.1 through 1.8.

2. Construction Costs

Closure construction costs include those for construction of the final cover system, site grading, and drainage improvements. Other costs may be added as site-specific issues warrant.

2.1. Mobilization

2.1.1. Mobilization of Personnel and Equipment

The cost of mobilizing personnel and construction heavy equipment must be included as part of the construction costs.

Enter additional work or cost element details for mobilization of personnel and equipment as site-specific conditions warrant:

2.2. Final Cover System

The owner or operator must install a final cover system that is designed to minimize infiltration and erosion. The final cover system is subdivided into the sideslope cover and cap cover with their associated components to facilitate cost calculations. If an alternative final cover is proposed, the closure cost estimate will still be based on a design that utilizes the conventional composite cover system.

Enter additional final cover system work or cost element details as site-specific conditions warrant:

2.2.1. Side Slope Cover

Enter information for Items 2.2.1a through 2.2.1h.

2.2.2. Top Slope Cover

Enter information for Items 2.2.2a through 2.2.2h.

2.2.3. Cells for Class 1 Nonhazardous Industrial Waste

2.3. Site Grading

Site grading includes the final grading of the site, including the landfill cap and sideslopes.

Enter additional site grading work or cost element details as site-specific conditions warrant:

Closure Cost Estimate for MSW Type I Landfill

Facility Name: TASWA Disposal and Recycling Facility

Revision No.: _____

Permit No: 2290A

Date: 3/28/2025

2.4. Site Fencing and Security

Site fencing and security must be included for the area which has received waste and have no existing approved fencing.

Enter additional site fencing and security work or cost element details as site-specific conditions warrant:

2.5. Landfill Gas Monitoring and Control Systems

Enter information for Items 2.5.1 through 2.5.6.

Final installation of the landfill gas monitoring and control systems must include the installation costs of pipes and appurtenances. In the event of a forced closure, the systems may not have been completed, thus, the estimated costs to complete the landfill gas monitoring and control system must be provided.

Enter additional landfill gas monitoring and control systems work or cost element details as site-specific conditions warrant:

2.6. Groundwater Monitoring System

2.6.1. Monitor Well Installation

Upon closure of the site, it may be necessary to relocate the compliance boundary. This requires the installation of new monitor wells.

Enter additional groundwater monitoring system work or cost element details as site-specific conditions warrant:

2.6.2. Piezometer and Monitor Well Plugging and Abandonment

Piezometer or monitor well abandonment is the cost of abandoning (plugging) piezometers or monitor wells that are no longer needed. Determine the number of piezometers or monitor wells to be abandoned and include the total cost.

Enter additional plugging and abandonment work or cost element details as site-specific conditions warrant:

2.7. Leachate Management

2.7.1. Completion of Existing Leachate Collection System

In the event of a forced closure, there may be circumstances where the leachate collection system has not been completed. In this event, the leachate collection system must be closed with a permanent outfalls and permanent cleanouts installed.

Enter additional leachate management work or cost element details as site-specific conditions warrant:

Closure Cost Estimate for MSW Type I Landfill

Facility Name: TASWA Disposal and Recycling Facility

Revision No.: _____

Permit No: 2290A

Date: 3/28/2025

2.8. Stormwater Management

2.8.1. Stormwater Drainage Management System

To reduce the potential long-term impacts of the landfill on surface water quality, drainage features must be incorporated into the final cover design to direct runoff, minimize erosion, control sediments, and avoid ponding of stormwater. The drainage system construction costs must be included.

Enter additional stormwater drainage management work or cost element details as site-specific conditions warrant:

2.9. Additional Construction Cost Items Not Listed on Worksheet

List the Attachments detailing any additional construction cost items necessary to close the site that is not already included as a line item on the worksheet:

Also, reference these Attachments in the "Units" column on this line of the worksheet. Provide the total cost of all additional construction cost items in the "Cost" column.

2.10. Construction Costs Subtotal

2.10.1. Enter the sum of construction costs in Items 2.1 through 2.9.

3. Storage and Processing Unit Closure Costs

For landfills that incorporate storage and/or processing operations that are not separately authorized, all waste and processed and unprocessed materials associated with storage and/or processing units must be removed during the closure process.

3.1. Waste Disposal

The cost of disposal of waste at an authorized facility. *Enter additional waste disposal work or cost element information as necessary.*

3.2. Material Removal and Disinfection

The cost of removal, including transportation, of any remaining processed and unprocessed materials to an authorized off-site location. *Enter additional material removal and disinfection work or cost element information as necessary.*

3.3. Demolition and Disposal

The cost of dismantling and/or disinfection of storage and/or processing units and disposal, as applicable. *Enter additional demolition and disposal work or cost element information as necessary.*

Closure Cost Estimate for MSW Type I Landfill

Facility Name: TASWA Disposal and Recycling Facility

Revision No.: _____

Permit No: 2290A

Date: 3/28/2025

3.4. Additional Storage and Processing Unit Closure Cost Items Not Listed in Worksheet

List the Attachments detailing any additional storage and processing unit closure cost items necessary to close the site that is not already included as a line item on the worksheet. Also, reference these Attachments in the "Units" column on this line of the worksheet. Provide the total cost of all additional storage and processing unit closure cost items in the "Cost" column.

3.5. Storage and Processing Unit Closure Costs Subtotal

4. Sum of Cost Subtotals

4.1. Enter the sum of engineering, construction, and storage and processing unit closure cost subtotals from lines 1.9.1, 2.10.1, and 3.5.1.

5. Contingency

5.1. Add an amount equal to at least 10 percent of the sum of cost subtotals to cover unanticipated events during implementation of closure activities.

6. Contract Performance Bond

6.1. Add an amount equal to at least 2 percent of the sum of cost subtotals for purchase of a surety bond to guarantee satisfactory completion of the closure activities.

7. Third Party Administration and Project Management Costs

7.1. Add an amount equal to at least 2.5 percent of the sum of cost subtotals to cover the cost for a third party hired by TCEQ to administer the closure activities.

8. Total Closure Cost

8.1. Enter the sum of the amounts on lines 4.1, 5.1, 6.1, and 7.1.

Closure Cost Estimate for MSW Type I Landfill

Facility Name: TASWA Disposal and Recycling Facility

Revision No.: _____

Permit No: 2290A

Date: 3/28/2025

IV. Closure Cost Estimates Worksheet

A. Landfill Data

Total Permitted Waste Disposal Area: 475.3 acres

Largest Area Requiring Final Cover in the year to follow: 84 acres

Total Filled Area with Constructed Final Cover: 0 acres

Total Area Certified Closed: 0 acres

Number of Monitor Wells to be Installed for Closure: 0

Number of Gas Probes to be Installed for Closure: 0

Total Acreage Needing LFG Collection and Control System: 0 acres

The unit or lump sum cost for each item is based on the work items and cost elements described in Section III of this Closure Cost Estimate document:

Yes No Partially

(if "No" or "Partially" is checked, please include attachments describing the additional work items and detailing the unit, quantities, and costs for the additional items)

B. Facility Drawings and Financial Assurance Documentation

- Facility drawings
 - Attach facility drawings showing the closure areas to which the closure cost estimates apply.
- Financial assurance documentation
 - For an existing facility, attach a copy of the documentation required to demonstrate financial assurance as specified in 30 TAC Chapter 37, Subchapter R.
 - For a new facility, a copy of the required documentation shall be submitted 60 days prior to the initial receipt of waste.

C. Attachments

- Additional Engineering, Construction, and Storage and Processing Units Cost Items Details

Closure Cost Estimate for MSW Type I Landfill

Facility Name: TASWA Disposal and Recycling Facility

Revision No.: _____

Permit No: 2290A

Date: 3/28/2025

D. Closure Cost Estimates Worksheet

If any item listed in this worksheet is not applicable to the subject facility, enter "NA" (Not Applicable) in the affected field.

Table 1. Closure Cost Estimates Worksheet.

Item No.	Item Description	Units ¹	Quantity	Unit Cost	Cost	Source of Unit Cost Estimate ²
1. Engineering Costs						
1.1	Topographic Survey	LS			15,000	2, 3
1.2	Boundary Survey	LS			10,000	2, 3
1.3	Site Evaluation	Acres			10,000	2, 3
1.4	Development of Plans	Lump Sum	NA	NA	50,000	2, 3
1.5	Contract Administration (bidding and award)	Lump Sum	NA	NA	10,000	2, 3
1.6	Closure Inspection and Testing	AC	84	10,000	840,000	2, 3
1.7	TPDES and other Permits	Lump Sum	NA	NA	15,000	2, 3
1.8	Additional Engineering Cost Items (describe in attachments)		NA	NA		NA
1.9 Engineering Costs Subtotal						
1.9.1	Engineering Costs Subtotal	NA	NA	NA	950,000	NA
2. Construction Costs						
2.1 Mobilization						
2.1.1	Mobilization of Personnel and Equipment	Lump Sum	NA	NA	100,000	
2.2 Final Cover System						
<i>2.2.1 Top and Side Slope Cover</i>						
2.2.1a	Infiltration Layer – Compacted Clay	Cubic Yards	203,280	3.00	609,840	2, 3
2.2.1b	Infiltration Layer – Geosynthetic Clay Liner	Square Feet				2, 3
2.2.1c	Flexible Membrane Cover – HDPE	Square Feet				2, 3
2.2.1d	Flexible Membrane Cover – LLDPE	Square Feet	3659040	0.50	1829520	2, 3

Closure Cost Estimate for MSW Type I Landfill

Facility Name: TASWA Disposal and Recycling Facility

Revision No.: _____

Permit No: 2290A

Date: 3/28/2025

Item No.	Item Description	Units ¹	Quantity	Unit Cost	Cost	Source of Unit Cost Estimate ²
2.2.1e	Drainage Layer – Geotextile	Square Feet	2134440	0.30	640332	2, 3
2.2.1f	Drainage Layer – Drainage Geocomposite Material	Square Feet	1524600	0.50	762300	2, 3
2.2.1g	Erosion Layer	Cubic Yards	271040	3.00	813120	2, 3
2.2.1h	Vegetation	Acres	84	2500	168000	2, 3
2.2.2 Top Slope Cover (See above)						
2.2.2a	Infiltration Layer – Compacted Clay	Cubic Yards				
2.2.2b	Infiltration Layer – Geosynthetic Clay Liner	Square Feet				
2.2.2c	Flexible Membrane Cover – HDPE	Square Feet				
2.2.2d	Flexible Membrane Cover – LLDPE	Square Feet				
2.2.2e	Drainage Layer – Aggregate	Cubic Yards				
2.2.2f	Drainage Layer – Drainage Geocomposite Material	Square Feet				
2.2.2g	Erosion Layer	Cubic Yards				
2.2.2h	Vegetation	Acres				
2.2.3 Cells for Class 1 Nonhazardous Industrial Waste						
2.2.3a	Dike Construction	N/A				
2.3 Site Grading						
2.3.1	Site Grading	Acres	84	2000	168000	2, 3
2.4 Site Fencing and Security						
2.4.1	Site Fencing and Security	N/A				
2.5 Landfill Gas Monitoring and Control System						
2.5.1	Gas Control Wells					
2.5.2	Gas Header Piping					
2.5.3	Gas Lateral Piping					

Closure Cost Estimate for MSW Type I Landfill

Facility Name: TASWA Disposal and Recycling Facility

Revision No.: _____

Permit No: 2290A

Date: 3/28/2025

Item No.	Item Description	Units ¹	Quantity	Unit Cost	Cost	Source of Unit Cost Estimate ²
2.5.4	Flare Station	Lump Sum				
2.5.5	Condensate Sumps					
2.5.6	Completion of LFG Monitoring System					
2.6 Groundwater Monitoring System						
2.6.1	Groundwater Monitoring Well Installation					
2.6.2	Piezometer and Monitor Well Plugging and Abandonment					
2.7 Leachate Management						
2.7.1	Completion of Leachate Management System	LS	1	25000	25000	2, 3
2.8 Stormwater Management						
2.8.1	Stormwater Drainage Management System	LS	1	20000	20000	2, 3
2.9 Other Cost Items						
2.9.1	Additional Construction Cost Items (describe in attachments)		NA	NA		NA
2.10 Construction Costs Subtotal						
2.10.1	Construction Costs Subtotal	NA	NA	NA	5178112	NA
3. Storage and Processing Unit Closure Costs						
3.1	Waste Disposal	<input type="checkbox"/> Tons <input type="checkbox"/> Cubic Yards				
3.2	Material Removal and Disinfection	LS	1	10,000	10,000	2, 3
3.3	Demolition and Disposal Units	LS	1	20,000	20,000	2, 3
3.4	Additional Storage and Processing Unit Closure Cost Items (describe in attachments)	identify attachments	NA	NA		NA
3.5 Storage and Processing Unit Closure Costs Subtotal						
3.5.1	Storage and Processing Unit Closure Costs Subtotal	NA	NA	NA	30,000	NA

Closure Cost Estimate for MSW Type I Landfill

Facility Name: TASWA Disposal and Recycling Facility

Revision No.: _____

Permit No: 2290A

Date: 3/28/2025

Item No.	Item Description	Units ¹	Quantity	Unit Cost	Cost	Source of Unit Cost Estimate ²
4. Sum of Engineering, Construction, and Storage and Processing Unit Closure Costs						
4.1	Sum of Engineering, Construction, and Storage and Processing Unit Closure Cost Subtotals	NA	NA	NA	6158112	NA
5. Contingency						
5.1	Contingency (10% of Sum of Engineering, Construction, and Storage and Processing Unit Closure Cost Subtotals)	NA	NA	NA	615811.20	NA
6. Contract Performance Bond						
6.1	Contract Performance Bond (2% of Sum of Engineering, Construction, and Storage and Processing Unit Closure Cost Subtotals)	NA	NA	NA	123162.24	NA
7. Third Party Administration and Project Management Costs						
7.1	Third Party Administration and Project Management Costs (2.5% of Sum of Engineering, Construction, and Storage and Processing Unit Closure Cost Subtotals)	NA	NA	NA	153952.80	NA
8. Total Closure Costs						
8.1	Total Closure Costs (sum of amounts in Sections 4, 5, 6, and 7)	NA	NA	NA	7051038.24	NA

¹ For items marked "specify," the responsible professional engineer will enter appropriate unit of measurement

² Sources of Unit Costs for Cost Estimates table may include:

- (1) Published Cost Estimator Manuals (e.g., RS Means);
- (2) Third Party Quotes (e.g., Environmental Field Services Contractors);
- (3) Verifiable Data based on Actual Operations; or
- (4) Other sources of cost acceptable to the executive director of the TCEQ.



Texas Commission on Environmental Quality Post-Closure Care Cost Estimate Form for Municipal Solid Waste Type I Landfills

This form is for use by applicants or site operators to provide post-closure care cost estimates for post-closure care of MSW Type I landfills to meet the requirements in 30 Texas Administrative Code (TAC) Chapter 330, Section 330.63(j) and 30 TAC Chapter 330 Subchapter L. The costs to be provided herein are cost estimates for hiring a third party to conduct post-closure care of the largest waste fill area that has been certified closed in writing by the TCEQ executive director.

If you need assistance in completing this form, please contact the MSW Permits Section in the Waste Permits Division at (512) 239-2335.

I. General Information

Facility Name: TASWA Disposal and Recycling Facility

MSW Permit No.: 2290A

Date: 3/27/25

Revision Number:

Site Operator/Permittee Name and Mailing Address: Texoma Area Solid Waste Authority

Total Post-Closure Care Cost Estimate (2025 Dollar Amount): \$5,717,756.40

II. Professional Engineer's Statement, Seal, and Signature

I am a licensed professional engineer in the State of Texas. To the best of my knowledge, this Post-Closure Care Cost Estimate has been completed in substantial conformance with the facility Post-Closure Care Plan and, in my professional opinion, is in compliance with Title 30 of the Texas Administrative Code, Chapter 330.

Name: David Clark Title: Engineer

Date: 3/27/25

Company Name: Biggs and Mathews Environmental Firm Registration Number: F-256

Professional Engineer's Seal

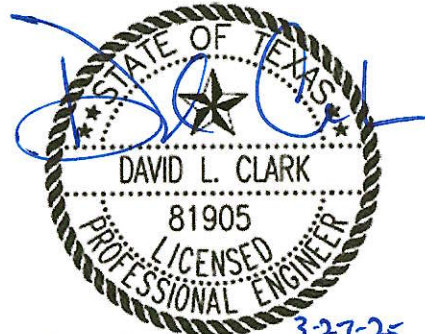

Signature

Biggs & Mathews Environmental, Inc.
Firm Registration No. F-256

Post-Closure Care Cost Estimate for MSW Type I Landfills

Facility Name: TASWA Disposal and Recycling Facility

Permit No: 2290A

Revision No.: _____

Date: 3/28/2025

III. Annual Review of Permit Conditions, Cost Estimates, Adjustments for Inflation, and Financial Assurance

The site operator/permittee acknowledges that he/she will:

1. Revise and increase the post-closure care cost estimate and the amount of financial assurance provided whenever changes in the post-closure care plan or the landfill conditions increase the maximum cost of post-closure care at any time during the remaining active life of the landfill and until the facility is officially released from the post-closure care period in writing by the executive director.
2. Request a reduction in the post-closure care cost estimate and the amount of financial assurance as a permit modification whenever the post-closure care cost estimate exceeds the maximum cost of post-closure care remaining over the post-closure period. The permit modification will include a detailed justification for the reduction of the post-closure care cost estimate and the amount of financial assurance.
3. Establish financial assurance for post-closure care of the unit in an amount no less than the current post-closure care cost estimate in accordance with 30 TAC Chapter 37
4. Adjust the current post-closure care cost estimate for inflation within 60 days prior to the anniversary date of the first establishment of the financial assurance mechanism.
5. Provide annual inflation adjustments to the post-closure care costs and financial assurance during the active life of the facility and during the post closure care period. The adjustment will be made using an inflation factor derived from the most recent annual Implicit Price Deflator for Gross National Product published by the United States Department of Commerce in its Survey of Current Business, as specified in 30 TAC Chapter 37. The inflation factor is the result of dividing the latest published annual Deflator by the Deflator for the previous year.
6. Provide continuous financial assurance coverage for post-closure care until the facility is officially released in writing by the executive director from the post-closure care period in accordance with all requirements of the post-closure care plan.

Post-Closure Care Cost Estimate for MSW Type I Landfills

Facility Name: TASWA Disposal and Recycling Facility

Revision No.: _____

Permit No: 2290A

Date: 3/28/2025

IV. Description of Worksheet Items of the Post-Closure Care Cost Estimates

The following descriptions of the worksheet items provide guidance for identifying the minimum work or cost elements for estimating the unit or lump sum cost of each item as applicable. Enter additional detail for each item in the field following the item as necessary and as site-specific conditions warrant. The cost items are grouped under post-closure care costs for engineering, construction, and leachate management. Include attachments to detail any additional work and associated costs necessary for the post-closure care of the unit or facility that is not already included as a line item on the worksheet. Reference the attachments and list the work or cost items in the fields under "Additional Engineering Cost Items Not Listed on the Worksheet," "Additional Construction Cost Items Not Listed on the Worksheet," or "Additional Leachate Management Costs Not Listed on the Worksheet" as applicable. Provide the total cost of additional work or cost items in each cost category on the worksheet line that precedes the cost subtotal for each cost group.

1. Engineering Costs

1.1. Site Inspection and Recordkeeping

Regularly scheduled and event-driven site inspection must be performed to identify areas experiencing settlement, subsidence, erosion, or other drainage related problems, and note the conditions of the environmental control and monitoring systems, including leachate collection, groundwater monitoring, and landfill gas monitoring systems. *Enter additional site inspection and recordkeeping work or cost element detail as site-specific conditions warrant.*

1.2. Correctional Plans and Specifications

The cost for an engineering consultant to prepare corrective measure construction plans and specifications to correct problems identified during site inspections. *Enter additional work or cost element details for correctional plans and specifications as site-specific conditions warrant.*

1.3. Site Monitoring

The cost of performing semiannual groundwater (including costs for sampling and analyzing parameters, and assessment and reporting) and quarterly landfill gas monitoring (including costs for sampling and reporting) and the monitoring of other site-specific systems at the landfill during the post-closure period. *Enter additional site monitoring work or cost element details as site-specific conditions warrant.*

Post-Closure Care Cost Estimate for MSW Type I Landfills

Facility Name: TASWA Disposal and Recycling Facility

Permit No: 2290A

Revision No.: _____

Date: 3/28/2025

1.4. Additional Engineering Cost Items Not Listed on the Worksheet

List the Attachments detailing additional post-closure care engineering cost items not already included as a line item on the worksheet. (Also, reference these Attachments in the "Units" column of this line of the worksheet. Provide the total cost of all additional engineering cost items in the "Cost" column).

Post-Closure Care Cost Estimate for MSW Type I Landfills

Facility Name: TASWA Disposal and Recycling Facility

Permit No: 2290A

Revision No.: _____

Date: 3/28/2025

2. Construction Costs

2.1. Cap and Sideslopes Repairs and Revegetation

The cost of repair of the cap and cap drainage control structures due to erosion or structural integrity failures and maintaining final cover vegetation to minimize erosion. *Enter additional cap and sideslopes repair and revegetation work or cost element details as site-specific conditions warrant.*

2.2. Mowing and Vegetation Control

The cost of controlling vegetation growth on the final cover and other areas of the landfill. *Enter additional mowing and vegetation control work or cost element details as site-specific conditions warrant.*

2.3. Groundwater Monitoring System Maintenance

The cost of repairs/replacement and routine maintenance. *Enter additional groundwater monitoring system maintenance work or cost element details as site-specific conditions warrant.*

2.4. LFG Monitoring Probes Maintenance

The cost of repairs/replacement and routine maintenance. Enter additional LFG monitoring probes maintenance work or cost element details as site-specific conditions warrant.

2.5. LFG Collection System Maintenance

The cost of repairs and routine maintenance. *Enter additional LFG collection system maintenance work or cost element details as site-specific conditions warrant.*

2.6. Perimeter Fence and Gates Maintenance

The cost of maintaining perimeter fence and gates to restrict unauthorized access to the closed landfill. *Enter additional perimeter fence and gates maintenance work or cost element details as site-specific conditions warrant.*

2.7. Access and Rights of Way Maintenance

The cost of maintaining the access roads and other rights of way to the closed landfill to conduct inspections, environmental sampling, routing

Post-Closure Care Cost Estimate for MSW Type I Landfills

Facility Name: TASWA Disposal and Recycling Facility

Revision No.: _____

Permit No: 2290A

Date: 3/28/2025

maintenance and other post-closure activities. *Enter additional access and rights of way maintenance work or cost element details as site-specific conditions warrant.*

2.8. Drainage System Cleanout and Repairs

The cost to include costs for maintaining and repairing ditches, conveyance structures, and ponds/basins. *Enter additional drainage system cleanout and repairs work or cost element details as site-specific conditions warrant.*

2.9. Additional Construction and Maintenance Cost Items Not Listed on the Worksheet

List the Attachments detailing any additional construction and maintenance cost items necessary for post-closure care that are not already covered on the worksheet. (Also, reference these Attachments in the "Units" column on this line of the worksheet. Provide the total cost of all additional construction and maintenance cost items in the "Cost" column.)

3. Leachate Management Costs

3.1. Leachate Collection and Removal System Operation and Maintenance

The cost of operation, routine maintenance and repairs. *Enter additional work or cost element details for leachate collection and removal system operation and maintenance as site-specific conditions warrant.*

3.2. Leachate Disposal

The cost of leachate disposal off-site. *Enter additional work or cost element details for leachate disposal as site-specific conditions warrant.*

3.3. Additional leachate management cost items not listed on the worksheet.

List the Attachments detailing any additional leachate management cost items necessary for post-closure care that are not already covered on the worksheet. (Also, reference these Attachments in the "Units" column on this line of the worksheet. Provide the total cost of all additional leachate management cost items in the "Cost" column.)

Post-Closure Care Cost Estimate for MSW Type I Landfills

Facility Name: TASWA Disposal and Recycling Facility

Permit No: 2290A

Revision No.: _____

Date: 3/28/2025

4. Sum of Cost Subtotals

Enter the sum of engineering, construction, and storage and leachate management post-closure care cost subtotals from lines 1.5.1, 2.10.1, and 3.5.1.

5. Contingency

The cost added to cover unanticipated events during implementation of post-closure activities. (Enter additional work or cost element information as necessary)

6. Third Party Administration and Project Management Costs

The cost for the third party hired by TCEQ to administer the post-closure activities. (Enter additional work or cost element information as necessary)

V. Post-Closure Care Cost Estimates Worksheet

Post-Closure Care Period – 30 years

Total Permitted Acreage: 689.5 acres

Total Permitted Waste Footprint: 475.3 acres

Number of Groundwater Monitoring Wells: 16

Number of GW Monitoring Events: 2/year

Number of Gas Probes: 10

Number of LFG Monitoring Events: 4/year

The unit or lump sum cost for each item is based on the work items and cost elements described in Section III of this Post-Closure Cost Estimate document:

Yes No Partially

If "No" or "Partially" is checked, please attach a written description of work items and cost elements which form the bases of unit or lump sum cost for the affected items.

(NOTE: If any item listed in this worksheet is not applicable to the subject facility, enter Not Applicable (N/A) in the affected fields)

Attachments

Additional Engineering, Construction, and Leachate Management Cost Items Details.

Post-Closure Care Cost Estimate for MSW Type I Landfills

Facility Name: TASWA Disposal and Recycling Facility

Revision No.: _____

Permit No: 2290A

Date: 3/28/2025

Table 1: Post-Closure Care Cost Estimates

Item No.	Item Description	Units	Annual Qty.	Unit Cost	Annual Cost	Source of Unit Cost Estimate ⁱ
1.0 Engineering Costs						
1.1	Site Inspection and Recordkeeping ⁱⁱ	LS	1	5000	5000	2, 3
1.2	Correctional Plans and Specifications	LS	1	10000	10000	2, 3
1.3 Site Monitoring						
<i>1.3.1 Groundwater Monitoring System</i>						
1.3.1(a)	Sampling and Analysis of GW Monitoring Wells (Quantity = 2 x Number of wells)	Wells	32	2500	80,000	2, 3
1.3.1(b)	Piezometers/Well Abandonment	Each				
<i>1.3.2 LFG Monitoring System</i>						
1.3.2(a)	LFG Quarterly Monitoring (Quarterly)	Each	4	3,000	12,000	2, 3
1.3.2(b)	LFG Probe Plugging and Abandonment	Each				
1.4 Additional Engineering Cost Items (Detail in Attachments)						
1.4.1	Additional Engineering Cost Items (describe in attachments)	Identif y attach ments	NA	NA		NA
1.5 Engineering Costs Subtotal						
1.5.1	Engineering Costs Subtotal	NA	NA	NA	107,000	NA
2.0 Construction and Maintenance Costs						
2.1	Cap and Sideslopes Repairs and Revegetation	Acres	84	65	5460	2, 3
2.2	Mowing and Vegetation Management	Acres	84	60	5040	2, 3

Post-Closure Care Cost Estimate for MSW Type I Landfills

Facility Name: TASWA Disposal and Recycling Facility

Revision No.: _____

Permit No: 2290A

Date: 3/28/2025

Item No.	Item Description	Units	Annual Qty.	Unit Cost	Annual Cost	Source of Unit Cost Estimate ⁱ
2.3	Groundwater Monitoring System Maintenance	LS	1	1,000	1,000	2, 3
2.4	LFG Monitoring Probes Maintenance	LS	1	1,000	1,000	2, 3
2.5	LFG Collection System Maintenance	LS	1	25000	25000	2, 3
2.6	Perimeter Fence and Gates Maintenance	LS	1	500	500	2, 3
2.7	Access Roads Maintenance	LS	1	500	500	2, 3
2.8	Drainage System Cleanout/Repairs	LS	1	1,000	1,000	2, 3
2.9 Additional Construction and Maintenance Cost Items (Details in Attachments)						
2.9.1	Additional Construction and Maintenance Cost Items (details in attachments)		NA	NA		NA
2.10 Construction and Maintenance Costs Subtotal						
2.10.1	Construction and Maintenance Costs Subtotal	NA	NA	NA	39,500	NA
3.0 Leachate Management						
3.1	Leachate Management System Operation and Maintenance	LS	1	10000	10000	2, 3
3.2	Leachate Disposal	Gals	86100	0.15	12915	2,3
3.3 Additional Leachate Management Cost Items (Details in Attachments)						
3.4	Additional Leachate Management Cost Items (details in attachments)		NA	NA		
3.5 Leachate Management Costs Subtotal						
3.5.1	Leachate Management Costs Subtotal	NA	NA	NA	22915	NA

Post-Closure Care Cost Estimate for MSW Type I Landfills

Facility Name: TASWA Disposal and Recycling Facility

Revision No.: _____

Permit No: 2290A

Date: 3/28/2025

Item No.	Item Description	Units	Annual Qty.	Unit Cost	Annual Cost	Source of Unit Cost Estimate ⁱ
4.0 Sum of Engineering, Construction, and Leachate Management Costs						
4.1	Sum of Engineering, Construction, and Leachate Management Cost Subtotals	NA	NA	NA	169415	NA
5.0 Contingency						
5.1	Contingency (10% of Sum of Engineering, Construction, and Leachate Management Cost Subtotals)	NA	NA	NA	16941.50	NA
6.0 Third Party Administration and Project Management Costs						
6.1	Third Party Administration and Project Management Costs (2.5% of Sum of Engineering, Construction, and Leachate Management Cost Subtotals)	NA	NA	NA	4235.38	NA
7. Total Post-Closure Cost						
7.1	Total Annual Post-Closure Cost (Sum of amounts in Sections 4, 5, and 6)	NA	NA	NA	190591.88	NA
7.2	30 Year Post-Closure Costs (Total Annual Post-Closure Cost x 30)	NA	NA	NA	5717756.40	NA

ⁱ Sources of Unit Cost Estimates may include:

- (1) Published Cost Estimator Manuals (e.g., RS Means);
- (2) Third Party Quotes (e.g., Environmental Field Services Contractors); or
- (3) Verifiable Data based on Actual Operations

ⁱⁱ Example Description for Item No. 1.1 – “Includes costs for site inspection performed at least annually for identification of areas experiencing settlement or subsidence, erosion or other drainage-related problems, inspection of the leachate collection system, gas monitoring system and LFG monitoring system.”

O:\TASWA\Drawings\J1_Largest.dwg Layout: J1 User: dclark

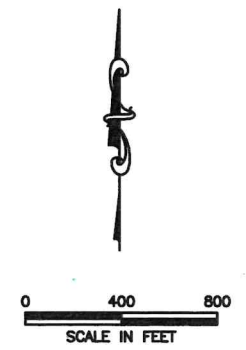
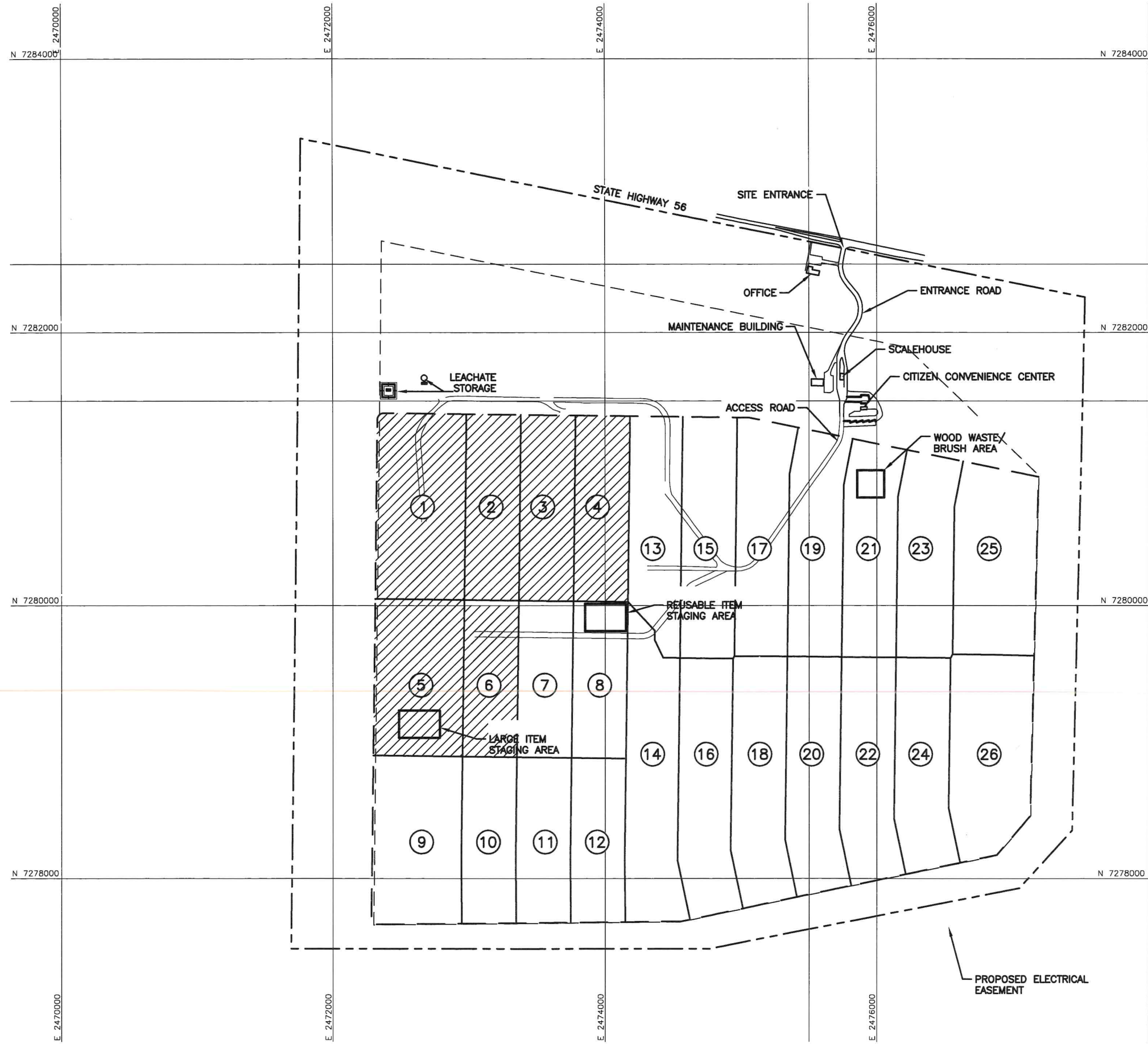

- LEGEND**
- 2290A PERMIT BOUNDARY
 - 2290A WASTE BOUNDARY
 - 2290 WASTE BOUNDARY
 - STATE PLANE COORDINATES
 - 750 EXISTING 10' GROUND CONTOUR
 - ⑭ SECTOR NUMBER (DEVELOPMENT SEQUENCE)
 - ▨ LARGEST AREA REQUIRING FINAL COVER (84 AC)

- NOTES:**
1. EXISTING GROUND CONTOURS PROVIDED BY BIGGS AND MATHEWS ENVIRONMENTAL FROM DRONE SURVEY FLOWN ON JUNE 1, 2022.

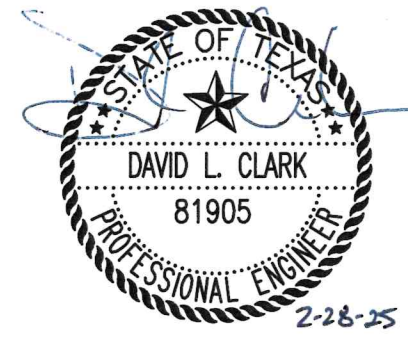

LARGEST AREA REQUIRING FINAL COVER	
TEXOMA AREA SOLID WASTE AUTHORITY TASWA RDF PERMIT AMENDMENT	
BME	BIGGS & MATHEWS ENVIRONMENTAL 1700 ROBERT ROAD, STE. 100 MANSFIELD, TEXAS 76063 817-563-1144
TBPE FIRM NO. F-256	DRAWING
TBPG FIRM NO. 50222	J.1

ISSUED FOR PERMITTING PURPOSES ONLY

EVIDENCE OF FINANCIAL ASSURANCE

CITY OF DENISON

City Hall
300 W. Main Street
Denison, TX 75020

940.465.2720 | Phone



March 4, 2025

Ms. Kelly Keel
Executive Director (MC-109)
ATTN: Ms. Deborah Wisneski
Texas Commission on Environmental Quality
P.O. Box 13087
Austin, Texas 78711-3087

Re: TEXOMA AREA SOLID WASTE AUTHORITY, INC., PERMIT NO. MSW-2290;
LOCAL GOVERNMENT FINANCIAL TEST LETTER FROM THE CHIEF
FINANCIAL OFFICER OF THE CITY OF DENISON, PROVIDER OF LOCAL
GOVERNMENT GUARANTEE

Dear Mr. Baker:

I am the chief financial officer of the City of Denison, 300 West Main Street, Denison, Texas 75020. This letter is in support of this local government's use of the financial test to demonstrate financial assurance, as specified in 30 Texas Administrative Code (TAC) Chapter 37 (relating to Financial Assurance).

Robert Crawley
Mayor

Michael Courtright
Council Place 1

James Thorne
Council Place 2

Joshua Massey
Council Place 3

Spence Redwine
Council Place 4

Aaron Thomas
Council Place 5

Teresa Adams
Council Place 6

Dobby Anteberry
Interim City Manager

1. This local government is the owner or operator of the following facilities for which financial assurance for closure, post closure, or corrective action is demonstrated through the financial test specified in 30 TAC §37.271 (relating to Local Government Financial Test). The current cost estimates covered by the test are shown for each facility: None.
2. This local government guarantees, through the guarantee specified in 30 TAC §37.281 (relating to Local Government Guarantee), the current closure, post closure, or corrective action cost estimates of the following facilities owned or operated by Texoma Area Solid Waste Authority, Inc., Permit No. MSW-2290, 25090 Hwy 56, Whitesboro, Texas 76273. The current cost estimates so guaranteed are shown for each facility: \$11,908,795.30 (Estimated Closure Cost \$9,279,167.18 + Estimated Post-Closure Cost \$2,629,628.13).

The fiscal year of this local government ends on September 30. The figures for the following items marked with an asterisk are derived from this local government's independently audited, year-end financial statements for the latest completed fiscal year, ended September 30, 2023.

Moving Forward. Kicking Back.



RATIO INDICATORS OF FINANCIAL STRENGTH

- | | | |
|-----|---|---------------|
| 1. | Sum of current cost estimates
(total of all cost estimates shown in the paragraphs above) | \$ <u>N/A</u> |
| *2. | Sum of cash and marketable securities | \$ _____ |
| *3. | Total expenditures | \$ _____ |
| *4. | Annual debt service | \$ _____ |
| 5. | Environmental obligations assured by a financial test to demonstrate financial assurance in the following amounts under commission regulations and the Code of Federal Regulations (CFR) or state equivalent rules: | |
| | (a) Municipal Solid Waste under 30 TAC Chapter 330 and 40 CFR Part 258 | \$ _____ |
| | (b) Hazardous waste treatment, storage and disposal facilities under 30 TAC Chapter 335 and 40 CFR Parts 264 and 265 | \$ _____ |
| | (c) Petroleum underground storage tanks under 30 TAC Chapter 334 and 40 CFR Part 280 | \$ _____ |
| | (d) Underground Injection Control System facilities under 30 TAC Chapter 331 and 40 CFR Part 144 | \$ _____ |
| | (e) PCB commercial storage facilities under 40 CFR Part 761 | \$ _____ |
| | (f) Additional environmental obligations not shown above | \$ _____ |
| | Total (a)-(f) | \$ _____ |
| *6. | Total Annual Revenue | \$ _____ |

Indicate either "yes" or "no" to the following questions.

- | | | |
|----|--|----------|
| 7. | Is line 2 divided by line 3 greater than or equal to 0.05? | (yes/no) |
| 8. | Is line 4 divided by line 3 less than or equal to 0.20? | (yes/no) |
| 9. | Is line 5 divided by line 6 less than or equal to 0.43? | (yes/no) |

BOND RATING INDICATOR OF FINANCIAL STRENGTH

Moving Forward. Kicking Back.



1.	Sum of current cost estimates (total of all cost estimates shown in the paragraphs above)	<u>\$11,908,795.30</u>
2.	List the following information on all the outstanding, rated, unsecured general obligation bonds issued to the local government: Current bond rating of most recent issuance and name of rating service	<u>A+ from Standard & Poor's</u>
	<u>General Obligation Refunding Bonds, Series 2013</u>	
	Date of issuance of bond	<u>2013 - \$3,442,800 at issuance</u>
	Date of maturity of bond	<u>2025 - \$885,000 outstanding</u>
	<u>General Obligation Refunding Bonds, Series 2019</u>	
	Date of issuance of bond	<u>2019 - \$3,060,000 at issuance</u>
	Date of maturity of bond	<u>2028 - \$1,685,000 outstanding</u>
	<u>General Obligation Refunding Bonds, Series 2020</u>	
	Date of issuance of bond	<u>2020 - \$4,045,000 at issuance</u>
	Date of maturity of bond	<u>2029 - \$2,755,000 outstanding</u>
3.	Environmental obligations assured by a financial test to demonstrate financial assurance in the following amounts under commission regulations and the Code of Federal Regulations (CFR) or state equivalent rules:	
(a)	Municipal Solid Waste under 30 TAC Chapter 330 and 40 CFR Part 258	<u>\$11,908,795.30</u>
(b)	Hazardous waste treatment, storage and disposal facilities under 30 TAC Chapter 335 and 40 CFR Parts 264 and 265	\$ _____
(c)	Petroleum underground storage tanks under 30 TAC Chapter 334 and 40 CFR Part 280	\$ _____
(d)	Underground Injection Control System facilities under 30 TAC Chapter 331 and 40 CFR Part 144	\$ _____
(e)	PCB commercial storage facilities under 40 CFR Part 761	\$ _____
(f)	Additional environmental obligations not shown above	\$ _____
	Total (a)-(f)	<u>\$11,908,795.30</u>
*4.	Total Annual Revenue	<u>\$44,182,230.00</u>



Indicate either "yes" or "no" to the following question.

5. Is line 3 divided by line 4 less than or equal to 0.43?

(yes) / no

I hereby certify that the wording of this letter is identical to the wording specified in 30 TAC §37.371 as such regulations were constituted on the date shown immediately below. I further certify the following: that the local government's financial statements are prepared in conformity with Generally Accepted Accounting Principles for governments, including conformance with General Accounting Standards Board Statement 18, and its financial statements have been audited by an independent Certified Public Accountant (CPA); that the local government has not operated at a deficit equal to 5.0% or more of total annual revenue in each of the past two fiscal years; that the local government is not in default on any outstanding general obligations bonds; that the local government does not have outstanding general obligations rated lower than Baa as issued by Moody's or BBB as issued by Standard and Poor's; and that the local government has not received an adverse opinion, disclaimer of opinion, or other qualified opinion from the independent CPA.

(Signature) Laurie Alsabbagh

(Name) Ms. Laurie Alsabbagh

(Title) Finance Director, City of Denison, Texas

(Date) _____

**TASWA DISPOSAL AND RECYCLING FACILITY
GRAYSON COUNTY, TEXAS
TCEQ PERMIT NO. MSW 2290A**

PERMIT AMENDMENT APPLICATION

PART IV

SITE OPERATING PLAN

Prepared for

Texoma Area Solid Waste Authority

February 2025
Revised June 2025



Biggs & Mathews Environmental, Inc.
Firm Registration No. F-256

Prepared by

BIGGS & MATHEWS ENVIRONMENTAL
1700 Robert Road, Suite 100 ♦ Mansfield, Texas 76063 ♦ 817-563-1144

TEXAS BOARD OF PROFESSIONAL ENGINEERS AND LAND SURVEYORS
FIRM REGISTRATION NO. F-256 AND NO. 10194895

TEXAS BOARD OF PROFESSIONAL GEOSCIENTISTS
FIRM REGISTRATION NO. 50222

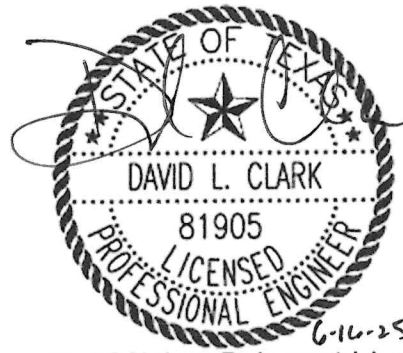

Biggs & Mathews Environmental, Inc.
Firm Registration No. F-256

CONTENTS

LIST OF ACRONYMS	iii
1 INTRODUCTION.....	1
2 RECORDKEEPING REQUIREMENTS	3
3 PERSONNEL AND TRAINING	7
4 EQUIPMENT	15
5 DETECTION AND PREVENTION OF DISPOSAL OF PROHIBITED WASTES.....	17
6 GENERAL INSTRUCTIONS	20
7 FIRE PROTECTION PLAN	23
8 OPERATIONAL PROCEDURES	27

APPENDIX IVA – EXAMPLE LOAD INSPECTION REPORT

APPENDIX IVB – FIRE PROTECTION SOILS CALCULATIONS

LIST OF ACRONYMS

ADC – Alternative Daily Cover
ADCOP – Alternative Daily Cover Operating Plan
CFR – Code of Federal Regulations
DOT – Department of Transportation
EPA – U.S. Environmental Protection Agency
FWS – U.S. Fish and Wildlife Service
GLER – Geosynthetics Liner Evaluation Report
LCS – Leachate Collection System
LFG – Landfill Gas
MSDS – Material Safety Data Sheets
msl – Mean Sea Level
MSW – Municipal Solid Waste
non-RACM – Nonregulated Asbestos-Containing Material
OSHA – Occupational Safety and Health Administration
PCBs – Polychlorinated Biphenyls
POTW – Publicly Owned Treatment Works
RACM – Regulated Asbestos-Containing Material
RCRA – Resource Conservation and Recovery Act
SLER – Soil Liner Evaluation Report
SOP – Site Operating Plan
SPCC – Spill Prevention Control and Countermeasures
SWPPP – Stormwater Pollution Prevention Plan
TAC – Texas Administrative Code
TASWA – Texoma Area Solid Waste Authority
TCEQ – Texas Commission on Environmental Quality
TxDOT – Texas Department of Transportation
TPWD – Texas Parks and Wildlife Department
WWTP – Wastewater Treatment Plant

1 INTRODUCTION

30 TAC §§330.65, 330.121, 330.123, 330.127

1.1 Introduction

This Site Operating Plan (SOP) has been prepared for the TASWA Disposal and Recycling Facility (TASWA DRF) in Grayson County, Texas. This SOP is consistent with 30 Texas Administrative Code (TAC) §330.65 and contains the information required by §330.127. This SOP includes provisions for site management and site operating personnel to meet the general and site-specific requirements included in Subchapter D, §§330.121 through 330.179, relating to Operational Standards for Municipal Solid Waste Landfill Facilities, and applicable sections of Subchapter E, §§330.201 through 330.249, relating to Operational Standards for Municipal Solid Waste Storage and Processing Units, for the day-to-day operation of the facility. This SOP will be retained on site throughout the active life of the facility and throughout the postclosure care maintenance period.

1.2 General

The following documents are operational requirements and are part of the site operating record of the TASWA DRF.

Operational requirements are included in the following:

- Municipal Solid Waste Disposal Permit No. 2290A
- Part III – Facility Investigation and Design
- Attachment A – Site Development Plan Narrative
- Attachment B – General Facility Design
- Attachment C – Facility Surface Water Drainage Report
- Attachment D – Waste Management Unit Design
- Attachment E – Geology Report
- Attachment F – Groundwater Monitoring Plan
- Attachment G – Landfill Gas Management Plan
- Attachment H – Closure Plan
- Attachment I – Postclosure Plan
- Attachment J – Cost Estimate for Closure and Postclosure Care
- Part IV – Site Operating Plan

1.3 Pre-Operation Notice

The facility, in accordance with §330.123, will provide notice of construction of a new waste disposal area (sector) or cell in the form of a Soil Liner Evaluation Report (SLER) and a Geosynthetics Liner Evaluation Report (GLER), to the executive director for review 14 days prior to the placement of waste. The executive director has 14 days to provide a verbal or written response. If no response has been received by the end of the

fourteenth day following the executive director's receipt of the report, the operator may begin placing waste.

2 RECORDKEEPING REQUIREMENTS

30 TAC §330.125

2.1 Documents

The TASWA DRF will maintain the operating record for the facility on site. Consistent with §330.125(a), copies of documents that are considered part of the site operating record are listed in the table below.

2.2 Analytical Data

The TASWA DRF, in accordance with §330.125(b), will record and retain in the site operating record those items listed in the table below within seven working days following completion or receipt of analytical data.

2.3 Operating Record

The TASWA DRF, in accordance with §330.125(c), will place the items included in the table below into the site operating record within the specified time period. The TASWA DRF will maintain the site operating record in an organized format, where information is easily locatable and retrievable. The site operating record will be furnished to the executive director upon request, and will be made available on site for inspection by the executive director.

2.4 Record Retention

The TASWA DRF, in accordance with §330.125(d), will retain all information contained within the site operating record of the facility and all plans required for the facility for the life of the facility including the postclosure care period.

2.5 Personnel Training Records and Licenses

In accordance with §330.125(e), the TASWA DRF will maintain personnel training records in accordance with §335.586(d) and (e). Personnel training requirements will be consistent with Section 3 – Personnel and Training of this SOP. Personnel training records for currently employed facility personnel will be maintained until closure of the facility. Records of former employees will be maintained for three years from the date the employee last worked at the facility. Records for each facility employee will include name, job title, job description, introductory training, continuing training, and documentation of training. In accordance with §330.125(f), the facility will maintain personnel operator licenses issued in accordance with Chapter 30, Subchapter F, relating to municipal solid waste facility supervisors. Personnel training records and personnel operator licenses will be maintained in the site operating record as listed in the table below.

2.6 Alternative Schedules

The executive director, in accordance with §330.125(g), may set alternative schedules for recordkeeping and notification requirements as specified in §330.125(a)-(f), except for notification requirements contained in Subchapter M of this chapter relating to location restrictions for any proposed lateral expansion located within a six-mile radius of any airport runway end used by turbojet or piston-type aircraft or notifications relating to landowners whose property overlies any part of the plume of contamination, if contaminants have migrated off site as indicated by groundwater sampling.

2.7 Annual Waste Acceptance Rate

As listed in the table below, the TASWA DRF will maintain as part of the site operating record documentation of the annual waste acceptance rate for the facility in accordance with §330.125(h). Records will include maintaining the quarterly solid waste summary reports and the annual solid waste summary report as required by §330.675. The annual waste acceptance rate, as established by the sum of the previous four quarterly summary reports, will be evaluated by the TASWA DRF to determine if the waste acceptance rate exceeds the rate estimated in the permit application. Should an increase in waste acceptance be established, the facility will determine if the increase is due to a temporary occurrence. Should the waste acceptance rate exceed that established in the permit application, and not be due to a temporary occurrence, a permit modification would be prepared in accordance with then applicable TCEQ regulations to propose changes, if necessary, to manage the increased waste acceptance rate to protect human health and the environment. An increase in the waste acceptance rate that is determined to be a temporary occurrence does not require the submittal of a permit modification. This SOP includes provisions for accommodating waste receipts up to 1,560,000 tons per year or about 5,000 tons per day.

**Records to be Maintained in the
Site Operating Record**

Records to be Maintained in the Site Operating Record	Frequency	Rule Citation
Municipal Solid Waste Disposal Permit No. 2290A	Submittal of Permit Amendment Application	§330.125(a)
Part I – Site and Applicant Information	Submittal of Permit Amendment Application	§330.125(a)
Part II – Existing Conditions and Character of the Facility and Surrounding Area	Submittal of Permit Amendment Application	§330.125(a) and §330.125(b)(1)
Part III – Facility Investigation and Design	Submittal of Permit Amendment Application	§330.125(a)
Attachment A – Site Development Plan Narrative	Submittal of Permit Amendment Application	§330.125(a)
Attachment B – General Facility Design	Submittal of Permit Amendment Application	§330.125(a)
Attachment C – Facility Surface Water Drainage Report	Submittal of Permit Amendment Application	§330.125(a)
Attachment D – Waste Management Unit Design	Submittal of Permit Amendment Application	§330.125(a)
Attachment E – Geology Report	Submittal of Permit Amendment Application	§330.125(a)
Attachment F – Groundwater Monitoring Plan	Submittal of Permit Amendment Application	§330.125(a)
Attachment G – Landfill Gas Management Plan	Submittal of Permit Amendment Application	§§330.125(a) and 330.159
Attachment H – Closure Plan	Submittal of Permit Amendment Application	§§330.125(a) and 330.125(b)(6)
Attachment I – Postclosure Plan	Submittal of Permit Amendment Application	§§330.125(a) and 330.125(b)(6)
Attachment J – Cost Estimate for Closure and Postclosure Care	Submittal of Permit Amendment Application	§§330.125(a) and 330.125(b)(7)
Part IV – Site Operating Plan	Submittal of Permit Amendment Application	§330.125(a)
State and Federal Regulations	Submittal of Permit Amendment Application	§330.125(a)
Location Restriction Demonstrations	Submittal of Permit Amendment Application	§330.125(b)(1)
Inspection records, training procedures and notification procedures related to excluding the receipt of prohibited waste	Per occurrence	§330.125(b)(2)
Results from gas monitoring events	Quarterly	§§330.125(b)(3) and 330.159
Remediation plans relating to explosive and other gases	Per occurrence	§§330.125(b)(3) and 330.159
Unit design documentation for the placement of leachate or gas condensate in the landfill	Per occurrence	§330.125(b)(4)
Groundwater monitoring and corrective action demonstrations, certifications, findings, monitoring, testing and analytical data	As required	§330.125(b)(5)
Closure and postclosure monitoring, testing, and analytical data	As required	§330.125(b)(6)
Cost estimates and financial assurance documentation for closure and postclosure	Annually	§330.125(b)(7)
Facility operation, permit modification, approvals, and technical assistance correspondence and responses	Per occurrence	§330.125(b)(9)

**Table 2-1
Records to be Maintained in the
Site Operating Record
(Continued)**

Records to be Maintained in the Site Operating Record	Frequency	Rule Citation
Special waste manifests, shipping documents, trip tickets, and all other documents relating to special waste	Per occurrence	§330.125(b)(10)
Other documents specified in the permit or by the executive director	As required	§330.125(b)(12)
Personnel training records in accordance with §335.586(d)-(e)	As needed	§330.125(e)
Personnel operator licenses	As needed	§330.125(f)
Records to document the annual waste acceptance rate including quarterly solid waste summary reports and annual solid waste summary reports	Quarterly and annually	§330.125(h)
Load inspection records	Per occurrence	§330.127(5)(B)
Fire occurrence notices	Per occurrence	§330.129
Inspection records and training procedures relating to fire prevention and site safety	As needed	§330.129
Access control breach and repair notices	Per occurrence	§330.131
A record of each unauthorized material removal event	Per occurrence	§330.133(b)
A record of alternate operating hours	As required	§330.135(d)
Water, crude oil and/or natural gas well location and plugging reports	Within 30 days of discovery	§330.161(a)-(c)
Cover inspection records	As required	§330.165(h)

3 PERSONNEL AND TRAINING

30 TAC §§330.127(1), (3), (4)

3.1 Personnel

The TASWA DRF will be staffed with qualified individuals experienced with municipal solid waste disposal operations and earthmoving construction projects. See Figure 3.1 – Organizational Chart for the personnel organization. Refer to the table below for a summary of job descriptions, minimum qualifications, and required training for landfill personnel.

Landfill Manager

The landfill manager (individual having managerial oversight of the facility, actual title may vary from the title stated in this SOP) is responsible for overall facility management and is designated as the contact person for regulatory compliance matters. The landfill manager is responsible for assuring that adequate personnel and equipment are available to provide facility operation in accordance with the Facility Investigation and Design, SOP, and the TCEQ regulations. The landfill manager is responsible for daily operations, administers the facility's SOP, and serves as the emergency coordinator. The landfill manager may designate other personnel to assist with the daily site operating requirements. The landfill manager, at a minimum, will meet the requirements for a Class A operator's license. The landfill manager will obtain and maintain the applicable required municipal solid waste operator license consistent with the requirements of §§30.201, 30.207, and 30.210 through 30.214. The landfill manager may obtain the applicable required license as a provisional license, consistent with the requirements of §30.211.

Lead Operator

The lead operator is responsible for actual landfill operations. The equipment operators receive direction from the lead operator regarding waste disposal operations including the active working face, excavation operations, and placement of daily and intermediate cover. The lead operator will report to the landfill manager. The lead operator, at a minimum, will have experience in earthmoving operations and have the ability to be trained in municipal solid waste disposal and landfill operations. The lead operator may obtain and maintain the applicable required municipal solid waste operator license consistent with the requirements of §§30.201, 30.207, and 30.210 through 30.214. The lead operator may obtain the applicable required license as a provisional license, consistent with the requirements of §30.211.

Scale Attendant

The scale attendant(s), stationed at the scalehouse, is primarily responsible for maintaining complete and accurate records of vehicles and solid waste entering the

facility. The scale attendant will be trained in site safety procedures, to visually check for unauthorized wastes, to weigh vehicles, measure waste volumes if necessary, and to collect waste disposal fees. The scale attendant will be present during the hours that the TASWA DRF is open to receive waste. The scale attendant will report to the landfill manager and, at a minimum, will have a basic understanding of accounting principles and basic communication skills.

Equipment Operator(s)

Equipment operator(s) are responsible for the safe operation of the equipment. As the personnel most closely involved with the actual landfill operations, these employees are responsible for being alert for potentially dangerous conditions, or careless and improper actions on the part of non-employees and other persons while on the premises. Equipment operators will monitor and direct unloading vehicles, visually observe for unauthorized wastes, and are responsible for maintenance, construction, litter abatement, and general site cleanup. The equipment operators will intervene as necessary to prevent accidents and report unsafe conditions immediately to the landfill manager. Equipment operators report to the lead operator. Equipment operators, at a minimum, must be experienced in the operation of heavy equipment, experienced in earthmoving operations, and demonstrate the ability to be trained in municipal solid waste disposal operations. Equipment operators will have a minimum of six months of experience in heavy equipment operation or on-the-job training by the lead operator, and training by the landfill manager in SOP requirements for daily cover and unauthorized waste.

Laborer(s)

Other site personnel or laborer(s) may be employed from time to time in categories such as maintenance, construction, litter abatement, and general site cleanup. Site personnel may be permanent or part-time.

3.2 General Instruction

TASWA DRF personnel should have a basic understanding of the contents of this SOP. The landfill manager should have a basic knowledge of the approved Part III – Facility Investigation and Design. TASWA DRF personnel will follow the general instructions provided in the SOP and the Facility Investigation and Design.

3.3 Training

The TASWA DRF personnel will be trained consistent with applicable training requirements as defined in §335.586(a) and (c). Training requirements are included in the table below.

The TASWA DRF personnel will receive training through a combination of classroom instruction and on-the-job training. The training program will provide instruction to personnel to allow performance of their duties to ensure facility compliance. This training program will be directed by a senior staff member of the TASWA organization.

The facility personnel will be trained in procedures relevant to the position for which they are employed. In-house training will address the following topics:

- Municipal Solid Waste Permit No. 2290A
- Site Development Plan (applicable sections)
- Site Operating Plan
- Facility emergency monitoring equipment and plans
- Communication and alarm systems
- Customer notification and load inspection procedures
- Identification of prohibited wastes including hazardous wastes and PCB wastes
- Waste handling procedures (acceptable and prohibited wastes)
- Health and safety
- Fire Protection Plan
- Equipment operation and maintenance
- Stormwater Pollution Prevention Plan
- Recordkeeping

The training program will incorporate the requirements of §335.586(a)(2) to train facility personnel to be able to respond effectively to emergencies by familiarizing personnel with emergency procedures, emergency equipment, and emergency systems, including:

- Procedures for using, inspecting, repairing, and replacing facility emergency and monitoring equipment
- Communications or alarm systems
- Response to fires or explosions
- Response to groundwater contamination incidents
- Shutdown of operations

The TASWA DRF personnel must successfully complete the in-house training program within six months of employment. The in-house training program consists of training and safety meetings conducted periodically. The topics addressed are the topics identified as part of the training program above. Personnel will be trained on topics relevant to their position.

Documentation of training will be placed in the site operating record as required by Section 2 – Recordkeeping Requirements. The landfill manager, lead operator, equipment operators, scale attendant, and other personnel will receive training at TCEQ-sponsored or approved training courses, as deemed appropriate by the landfill manager.

Figure 3.1
Organizational Chart

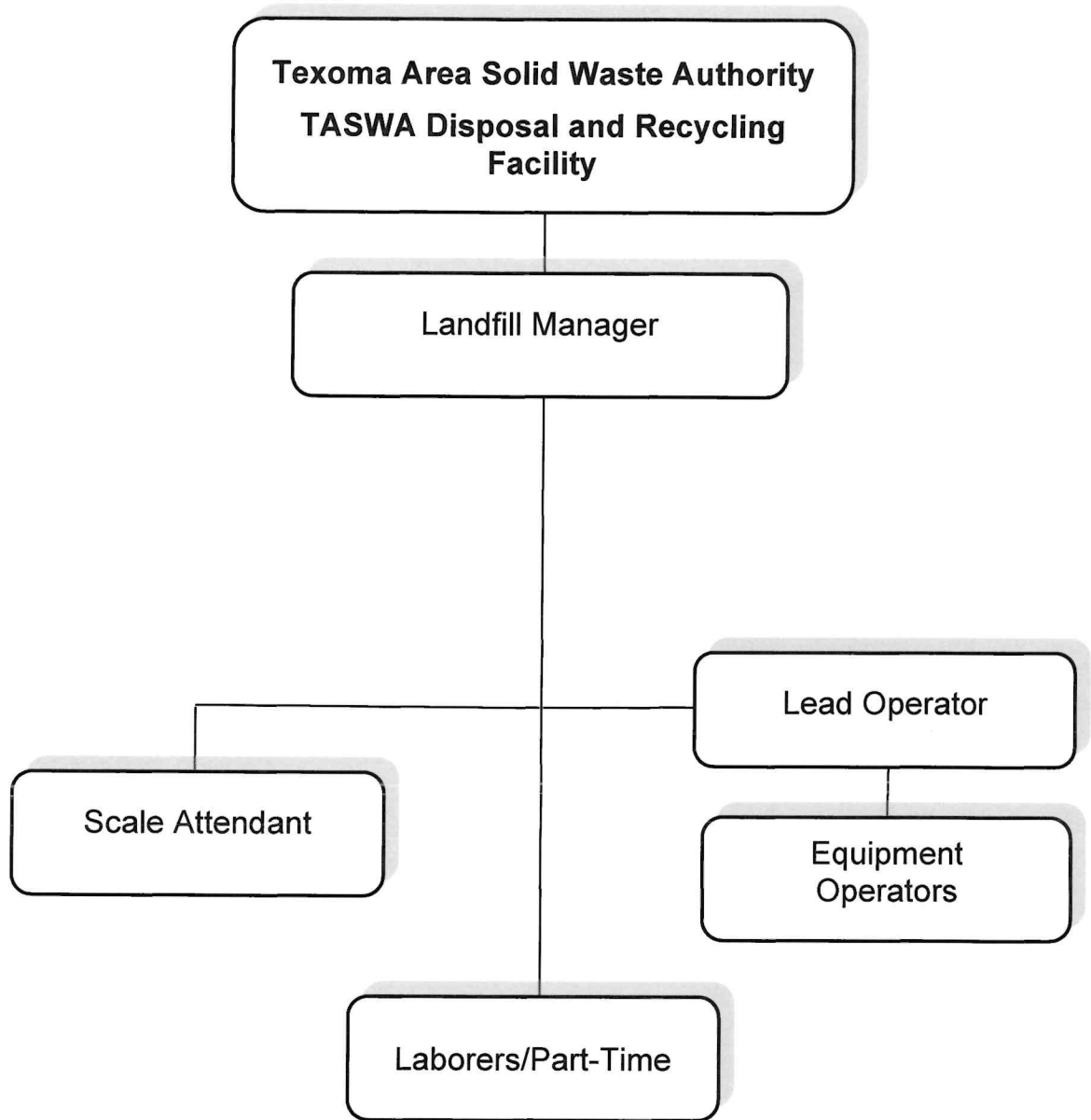

Site Personnel Summary

Position	Summary of Job Description	Minimum Qualifications	Required Training
Landfill Manager	<p>The landfill manager is responsible for:</p> <ul style="list-style-type: none"> • Overall facility management and is the designated contact person for regulatory compliance matters • Daily operations, administration of facility's Facility Investigation and Design, SOP, bird control, site safety, waste inspections and serving as the emergency coordinator • Assuring that adequate personnel and equipment are available to provide facility operation in accordance with this SOP, the SDP, TCEQ regulations, and other applicable local, state or federal regulations • Maintaining the site operating record and required logs • The hiring and terminating of other facility personnel • Designating other personnel to assist with the daily site operating requirements as related to bird control, waste inspections and other appropriate activities 	<ul style="list-style-type: none"> • Experience in earthmoving operations • Experience in MSW disposal operations • Maintains a license consistent with the requirements of §§30.201, 30.207, and 30.210 through 30.214 	<ul style="list-style-type: none"> • Site Orientation • Site Operations • Hazardous Waste Identification • Safety • Fire Prevention • Load Inspection • Prohibited Wastes • Emergency Response • SPCC • SWPPP • Litter Control • Random Inspections

**Site Personnel Summary
(Continued)**

<p>Lead Operator</p>	<p>The lead operator is responsible for:</p> <ul style="list-style-type: none"> • Actual landfill operations • Directing the equipment operators on a daily basis regarding waste disposal operations including the working face, excavation operations, and placement of daily and intermediate cover • Personnel safety during waste and cover construction • Other tasks as required by the landfill manager 	<ul style="list-style-type: none"> • Experience in earthmoving operations • Experience in MSW disposal operations • Maintains licensing consistent with the requirements of §§30.201, 30.207, and 30.210 through 30.214 	<ul style="list-style-type: none"> • Site Orientation • Site Operations • Hazardous Waste Identification • Safety • Fire Prevention • Load Inspection • Prohibited Wastes • Emergency Response • SPCC • SWPPP • Litter Control • Random Inspections
----------------------	---	--	---

Site Personnel Summary (Continued)

<p>Office Clerk/Scale Attendant</p>	<p>The scale attendant is responsible for:</p> <ul style="list-style-type: none"> • Being stationed at the site entrance • Maintaining complete and accurate records of vehicles and solid waste entering the facility • Visually checking for unauthorized wastes • Weighing vehicles or measuring waste volumes (if necessary) • Collecting waste disposal fees • Directing vehicles to the working face • Controlling site access • Providing general customer direction and information • Reviewing manifests and other shipping documents • Reviewing and confirming special waste documents • Other tasks as required by the site manager 	<ul style="list-style-type: none"> • Basic understanding of accounting principles • Basic communication skills 	<ul style="list-style-type: none"> • Site Orientation • Hazardous Waste Identification • Safety • Fire Prevention • Load Inspection • Prohibited Wastes • Emergency Response • SPCC • Random Inspections
<p>Equipment Operator</p>	<p>The equipment operator is responsible for:</p> <ul style="list-style-type: none"> • The safe operation of equipment • Being alert for potentially dangerous conditions, or careless and improper actions on the part of non-employees and other persons while on the premises • Monitoring and directing unloading vehicles • Performing random load inspections • Maintenance, construction, litter abatement, and general site cleanup • Intervening as necessary to prevent accidents and report unsafe conditions immediately to the lead operator or landfill manager • Other tasks as required by the landfill manager 	<ul style="list-style-type: none"> • Minimum six months experience in heavy equipment operation or on-the-job training by the lead operator • Ability to be trained in municipal solid waste disposal operations • Training by the landfill manager in SOP requirements for daily cover and unauthorized waste • May be trained in bird control activities 	<ul style="list-style-type: none"> • Site Operations • Site Orientation • Hazardous Waste Identification • Safety • Fire Prevention • Load Inspection • Prohibited Wastes • Emergency Response • SPCC • SWPPP • Litter Control • Random Inspections

Site Personnel Summary (Continued)

<p>Laborers/Part-time Laborers</p>	<p>The laborers are responsible for:</p> <ul style="list-style-type: none"> • Collecting litter • Directing vehicles at the working face • Other tasks as needed including but not limited to maintenance, construction, litter abatement, and general site cleanup 	<ul style="list-style-type: none"> • Ability to be trained in completing the assigned tasks 	<ul style="list-style-type: none"> • Site Orientation • Safety • Fire Prevention • Emergency Response • Litter Control • SPCC • SWPPP
------------------------------------	--	--	--

¹More detailed job descriptions along with written descriptions of the type and amount of introductory and continued training provided to each employee will be maintained in the site operating record.

4 EQUIPMENT

30 TAC §330.127(2)

Sufficient equipment will be provided to conduct site operations in accordance with the landfill design and permit conditions.

The following list of equipment is expected to be routinely available for use at the facility. Equipment requirements may vary in accordance with the method of landfill operations or the waste acceptance rate at any given time. Additional equipment will be provided as required for increasing volumes of incoming solid waste. Other equivalent types of equipment by other manufacturers may be substituted on an as-needed basis. The minimum number of pieces of equipment to be provided for daily operations is listed in the table below.

The size, number, types, and equipment manufacturers will vary during site operations based on operational practices and on the annual waste acceptance rate. The equipment table identifies equipment required for the operational provisions of the landfill for accommodating waste receipts up to the estimated maximum annual waste acceptance rate.

Compactors are typically used for spreading and compacting the refuse and also for compacting the cover material. Dozers are typically used for soil movement and placement, to place and remove intermediate cover, for fire control, and for emergency waste compaction. Scrapers or excavators and haul trucks are typically used for excavating and moving both the cover material used in site operations and soil from the future disposal areas and for fire control. The landfill will use either scrapers or an excavator and haul trucks for soil excavation and movement. The motor grader or dozer is typically used for road maintenance, ditching, surface water control, and final grading of the completed fill areas. The water truck will be used for dust control, moisture condition of soil materials as necessary, fire control measures at the working face, haul water for irrigation, and to supply construction water. A farm tractor with various attachments may be used for certain tasks including mud removal from site roads, mowing vegetative cover and other vegetative growth, site maintenance, erosion control placement, litter control, and other miscellaneous tasks. A farm tractor and pickup truck(s) will be used as needed for miscellaneous maintenance, litter control, and personnel use. Backup equipment will be provided from contractors or local rental companies in the event of a breakdown or maintenance to avoid interruption of waste services.

In addition to the equipment listed in the table below, miscellaneous pickups, vans, or other light utility vehicles, as well as various portable pumps, instruments, and safety and training equipment will be on site as needed for operational efficiency.

Equipment operators may perform routine cleaning of landfill equipment using low-volume, high-pressure spray equipment at the active working face of the landfill over Subtitle D lined areas.

**Table 4-1
Equipment Dedicated to the TASWA DRF⁽¹⁾**

Equipment	Typical Size	Number ⁽⁴⁾		Function
		Less than 2,500 tpd	2501 to 5,000 tpd	
Compactor(s)	CAT 826, 836	1	2	Trash Compaction, fire control
Dozer(s) and/or Track Loader	CAT D7, D8	1	2	Soil movement and placement, fire control, Roadway maintenance
	Cat 973	1	2	
Excavator ⁽²⁾ Haul Trucks ⁽²⁾	CAT 330C	1	1	Soil Excavation and hauling, fire control
	10 to 40 ton	1	2	
Motor Grader ⁽⁵⁾	CAT 120A, 12G, JD772	1	1	Roadway maintenance
Farm Tractor	50 HP	1	1	Miscellaneous maintenance
Pickup Truck(s)	½ ton	1	1	Personnel use, litter control, maintenance
Water Truck(s)	2,000 gallons	1	1	Dust control, earthfill compaction, fire control
Pump(s)	10 to 1,000 gpm	2	2	Stormwater, groundwater, and contaminated water pumping

⁽¹⁾The manufacturers of heavy equipment and miscellaneous vehicles and equipment may vary.

⁽²⁾Soil excavation will be conducted with excavator and haul trucks. Scraper(s) may also be used for soil excavation and hauling.

⁽³⁾Backup equipment will be provided from contractors or local rental companies in the event of an equipment breakdown or maintenance to avoid interruption of waste services.

⁽⁴⁾The number stated for each piece of equipment is the minimum number for each piece of equipment to be provided.

⁽⁵⁾Road maintenance may be performed by dozer or tractor in place of motor grader.

5 DETECTION AND PREVENTION OF DISPOSAL OF PROHIBITED WASTES

30 TAC §330.127(5)

5.1 General

The TASWA DRF, in accordance with §330.127(5), has established procedures for the detection and prevention of the disposal of prohibited wastes, including prohibited waste as defined in §330.15(e), regulated hazardous waste as defined in 40 CFR Part 261, and polychlorinated biphenyls (PCB) waste as defined in 40 CFR Part 761 unless authorized by the United States Environmental Protection Agency (EPA). The detection and prevention program will include training site personnel to know in detail what the regulated wastes are, how to perform a random inspection, how to control site access, what training will be provided for site personnel, and what procedures are required in the event of identification of prohibited wastes. The detection and prevention program includes the following steps:

- Random inspections of incoming loads.
- Records of all inspections.
- Training for appropriate facility personnel to recognize prohibited waste, regulated hazardous waste and PCB waste.
- Notification to TCEQ of any incident involving the receipt or disposal of regulated hazardous waste or PCB waste at the landfill.
- Provisions for remediation of the incident.
- Identification and sampling to ensure no free liquids (as determined by the paint filter test), including unstabilized sludges, will be disposed of prior to stabilization.

5.2 Load Inspection Procedure

A properly trained and qualified staff person at the working face will visually observe all incoming waste loads. All vehicles, including compactor vehicles, will be visually observed as waste is discharged at the working face. Should any indication of prohibited waste be detected, or as directed by the landfill manager, appropriate facility personnel will attempt to stop vehicle unloading to allow facility personnel to conduct a thorough evaluation of the load. The driver will be directed to an area located near the working face over an approved lined area, where the balance of the load will be discharged from the vehicle. Facility personnel will observe the waste pile and inspect the material for any prohibited waste. Known prohibited waste will be placed back into the vehicle and the driver will be instructed to depart the site.

Should any regulated hazardous waste be detected, the entire load will be refused and recoverable materials will be loaded back into the waste hauling vehicle.

In addition to the above procedure, all incoming loads will be inspected on a random basis. The landfill manager will be responsible for determining the random inspection schedule, with a minimum of six inspections per week performed by properly trained and qualified personnel. The driver of the randomly selected load will be notified at the scalehouse or at the working face and instructed to proceed as above to a load inspection area located over an approved lined area.

5.3 Recordkeeping

The landfill manager is required to maintain and include in the site operating record the following:

- Load inspection reports for randomly inspected loads
- Records of regulated hazardous or PCB waste notifications
- Personnel training records

Load inspection reports, recorded on standardized forms, will be completed for each inspected load. The reports will include, at a minimum, the date and time of inspection, the name of the hauling company and driver, the type of vehicle, the size and source of the load, contents of the load, indicators of prohibited waste, and results of the inspection. A copy of a sample load inspection report form is included in Appendix IVA.

The TCEQ will be notified whenever regulated hazardous or PCB waste is detected. Records of the notification will be kept in the site operating record and will include the date and time of notification, the individual contacted, and the information reported.

Personnel training records will be maintained in the site operating record and will include evidence of successful completion of the training, type of training received, and the name of the instructor.

5.4 Training

The landfill manager, lead operator, equipment operators, and scale attendant will maintain a thorough understanding of this SOP and will be trained in the following areas:

- Customer notification and load inspection procedures
- Identification of regulated hazardous, PCB, and prohibited waste
- Waste handling procedures

- Health and safety procedures
- Recordkeeping

Documentation of training will be placed in the site operating record.

5.5 Notification

The TCEQ executive director will be notified of any incident involving the receipt or disposal of regulated hazardous waste or PCB waste at the landfill. Records of notifications will be maintained in the site operating record including date and time of notification, the individual contacted, and the information reported.

5.6 Managing Prohibited Wastes

Known prohibited wastes detected during the inspection will be returned immediately to the hauler. If the hauler is not available, the waste will be safely stored until provisions for removal can be arranged.

If regulated hazardous or PCB wastes are detected, the TCEQ will be notified. As soon as practical, the hauler will be required to remove the hazardous waste from the site.

6 GENERAL INSTRUCTIONS

30 TAC §330.127(6)

6.1 General Site Safety

Site safety will be promoted by properly trained personnel using well maintained equipment to perform standard work procedures. Site safety will be enhanced by limiting access to the active areas to only authorized personnel. In the event of an emergency, planned emergency response procedures will be followed.

Well maintained equipment is vital to the safe conduct of daily landfilling operations. Therefore, all site equipment will be maintained in proper working order and all safety guards, backup alarms, and engine kill switches will be operational. Equipment operators will perform an equipment check at the beginning of each workday. Problems will be reported to the landfill manager. The facility will inspect the fire extinguishers and first aid kits monthly. Records of all inspections will be maintained as part of the site operating record.

Access to the site is limited to authorized personnel as described in Section 8. Access is controlled by a combination of signs and physical barriers. Site personnel should be alert to the entrance of authorized or unauthorized personnel into prohibited areas.

In the event of an emergency, site personnel will assess the situation, notify the landfill manager or designated supervisor, and take appropriate actions such as rendering aid, calling for assistance, and closing access to the emergency scene. Emergency numbers will be posted beside the telephone in the scalehouse.

These include:

OFFICE	PHONE
Ambulance	911
Whitesboro Fire Department	911
Whitesboro Police Department	911
Grayson County Sheriff's Office	911

6.2 Preparedness and Prevention Measures

Preparedness and prevention measures have been developed to minimize both the frequency and severity of accidents and emergency situations threatening human health. Preparedness and prevention measures depend largely on the attentiveness and state of readiness of facility personnel. Preparedness and prevention measures have been developed for one general category and two specific areas of the site: the scalehouse and the on-site access routes. These preparedness and prevention measures are detailed in the following sections.

6.2.1 General

General preparedness and prevention measures that will be followed are:

- Employee breaks or rest periods will be provided to minimize fatigue, improve alertness, and thereby reduce accident potential.
- Access controls will provide for the safety of non-landfill personnel.
- Routine preventive maintenance of equipment will be provided.
- Daily and weekly site inspections of the working areas will be performed by a management representative.
- Appropriate personal safety equipment will be kept on site and maintained in good repair. Site personnel will be furnished with hard hats, dust and hearing protection, and safety glasses as needed.
- Adequate turning area for hauling vehicles will be provided.
- Scavenging and unauthorized salvaging will not be allowed and individuals will be required to stay close to their vehicles for their own protection.
- Waste unloading will be restricted to designated areas only.
- Site personnel will be alert for possible hazardous or other unauthorized wastes.
- Non-approved wastes will be controlled or contained and removed as necessary.
- Smoking is not allowed on the active areas of the landfill.

6.2.2 Scalehouse

Preventative measures that will be followed in the scalehouse include the following:

- Visually screen all incoming waste loads for unauthorized wastes.

- Monitor to see that all waste loads are adequately covered, or otherwise protected or contained.
- Visually observe incoming vehicles for evidence of improper operation, faulty equipment, or other conditions that could be hazardous to personnel or other persons on site.
- Maintain access to appropriate emergency equipment and first-aid supplies.
- Provide emergency telephone numbers that are conspicuously posted in the scalehouse.
- Display signs warning transporters that particular wastes, including regulated hazardous wastes and other nonallowable special wastes, are prohibited.

6.2.3 Landfill Entrance Road, Haul Road, and Access Road

Landfill entrance road, haul road, and access road preventative measures include the following:

- Display speed limit, directional, and other precautionary signs.
- Provide road passable for two-way traffic.
- Maintain roadway free from obstructions.
- Enforce requirements for safe operation of vehicles on site.

7 FIRE PROTECTION PLAN

30 TAC §330.129

7.1 Fire Prevention Procedures

The following steps will be taken regularly by designated landfill personnel to prevent fires:

- Open burning of waste is prohibited at all times.
- Incoming loads with burning waste will be prevented from being dumped in the active area of the landfill. The scale attendant and equipment operators will be alert for signs of burning waste such as smoke, steam, or heat being released from incoming waste loads.
- Should an incoming load with burning waste be observed at the scalehouse or active working face, the scale attendant or equipment operator will direct the driver to a designated area away from the active working face to unload. The burning waste will then be extinguished with water, fire extinguishers, or will be covered with soil to smother the fire.
- Fuel spills will be contained and cleaned up immediately.
- Dead trees, brush, or vegetation adjacent to the active waste disposal area will be removed immediately and grass and weeds mowed so that forest, grass, or brush fires cannot spread to the landfill.
- Smoking is not allowed on the active working face, refueling area, and other fire sensitive areas of the landfill. Smoking will be allowed in designated areas only.
- The site will be equipped with fire extinguishers in appropriate locations. Each fire extinguisher will be fully charged and ready for use at all times. Each extinguisher will be inspected on an annual basis and recharged as necessary. These inspections will be performed by a qualified service company, and all extinguishers will display a current inspection tag. Inspection and recharging will be performed following each use. At a minimum, the scalehouse, maintenance building, citizen convenience center, and all landfill heavy equipment will be equipped with fire extinguishers.
- A common firefighting technique that can be quickly employed to fight a landfill fire is smothering with soil. The faster that soil can be placed over the fire, the more effective this method will be in controlling and extinguishing the fire. The stockpiled daily cover may be used for firefighting purposes.

- A stockpile of earthen material will be maintained so that it is available at all times to extinguish a fire. At least two soil sources will be provided. A stockpile will be provided adjacent to the working face, and a second soil stockpile or soil borrow source will be provided within 2,500 feet of the active working face. The landfill equipment conducting daily waste filling operations will be suitable for placement of additional soil from the earthen sources for fire control.
- The total volume of earthen material available from the two stockpiles will be sized to cover the working face with a minimum 6-inch layer of earthen material.
- Based on achievable production rates, the landfill equipment is sufficient to cover the active working face with a minimum 6-inch soil layer from a soil stockpile within one hour of detecting a fire as demonstrated in Appendix IVB.
- The active working face will be limited to the total capacity of the dozer and compactor capacity and the scrapper/excavator and haul truck capacity unless larger equipment or additional capacity is provided.

7.2 Specific Firefighting Procedures

The following procedures will be followed in the event of a fire:

- If a fire occurs on a vehicle or piece of equipment, the equipment operator should bring the vehicle or equipment to a safe stop. If safety of personnel will allow, the vehicle must be parked away from fuel supplies, uncovered solid wastes, and other vehicles. The engine should be shut off and the brake engaged to prevent movement of the vehicle or piece of equipment. Fire extinguishers should be used to extinguish the fire, if possible, without risk to the equipment operator.
- Incoming loads with burning waste will be prevented from being unloaded in the active working face of the landfill. The scale attendant and equipment operators will be alert for signs of these loads, such as smoke, steam, or heat being released from incoming waste loads. Should a load with burning waste be observed at the scale or active working face, the scale attendant or equipment operator will direct the driver to a designated area away from the active working face to unload. The load will be covered with soil to smother the fire.
- If a fire is in the working face, the burning area should be isolated or pushed away from the active working face before the fire can spread to other areas of the working face. If isolating or pushing the fire is not feasible or is unsafe, the working face should immediately be covered with earthen material from the stockpile to smother the fire.
- If a fire occurs at the citizen's convenience center, landfill personnel should use fire extinguishers to extinguish the fire, if possible. The general rules for fires will be implemented as included in Section 7.3 to protect landfill personnel or visitors.

- Firefighting methods include smothering with soil, separating burning material from other waste, and spraying with water from the water truck or water pumped from nearby ponds or streams. If detected soon enough, a small fire may be fought with a hand-held fire extinguisher. Fire extinguishers will be located at the scalehouse, maintenance building, citizen's convenience center, and all landfill heavy equipment. Under this circumstance, the fire area should also be watered or otherwise controlled to ensure that the fire is out.

7.3 General Rules for Fires

The following rules will be implemented in the event of a fire at the TASWA DRF:

- Immediately contact the scalehouse and landfill manager. Equipment operators will be equipped with two-way radios or cell phones.
- Alert other facility personnel.
- Assess extent of fire, possibilities for the fire to spread, and options for extinguishing the fire.
- If it appears that the fire can be safely fought with available fire-fighting devices, attempt to contain or extinguish the fire.
- If landfill personnel cannot extinguish the fire, contact the Fire Department by calling 911.
- Upon arrival of the Fire Department personnel, direct them to the fire and provide assistance as appropriate.
- Do not attempt to fight the fire alone.
- Do not attempt to fight the fire without adequate personal protective equipment.
- Be familiar with the use and limitations of fire-fighting equipment available on site.

7.4 Fire Protection Training

Landfill personnel will be trained in the contents of Section 7 – Fire Protection Plan in accordance with Section 3.3 – Training. Landfill personnel will maintain a thorough understanding of this SOP and will be trained in fire prevention and fire control as defined in this section. The following topics will be addressed:

- Identification of burning waste, smoke, steam, or heat being released from incoming waste loads
- Procedures to prevent and contain fuel spills

- Fire prevention
- Fire safety
- Firefighting procedures with fire extinguishers, soil, and water as appropriate
- Notification procedures should a landfill fire be observed

In addition, information will be provided to the local fire department regarding waste disposal operations, fire sources, and firefighting techniques related to landfills. Documentation of training will be placed in the site operating record in accordance with Section 3.3.

7.5 TCEQ Notification

In the event of a fire that is not extinguished within 10 minutes of detection, the TCEQ region office will be contacted immediately after detection, but no later than four hours by phone and in writing within 14 days. The notification will include a description of the fire and resulting response.

8 OPERATIONAL PROCEDURES

30 TAC §§330.131-330.175

8.1 Access Control

Public access to the landfill will be controlled by a perimeter fence located along the property boundary or highway/road right-of-way. Access to the landfill from SH56 is limited to the entrance road through the scalehouse area. The scale attendant controls access and monitors all vehicles entering and exiting the site. Separate controlled access for operation of a Landfill Gas-to-Energy (LFGTE) facility may be established for operators and/or monitors of the LFGTE facility.

8.1.1 Site Security

Site security measures are designed to prevent unauthorized persons from entering the site, to protect the facility and its equipment from possible damage caused by trespassers, and to prevent disruption of facility operations caused by unauthorized site entry.

Unauthorized entry into the site is minimized by controlling access to the landfill site with the perimeter fence and entrance gate. A perimeter fence is located along the property and/or permit boundary. Perimeter fencing consisting of barbed wire, woven wire, wooden fencing, plastic fencing, pipe fencing, or other suitable material may be provided. A gate constructed of suitable fencing materials is located on the entrance road. Entrance to the landfill is monitored by the scale attendant during site operating hours at the scalehouse. Outside of operating hours, the gate located on the entrance road will be locked.

Entry to the active portion of the site will be restricted to designated personnel, approved waste haulers, and properly identified persons whose entry is authorized by site management. Visitors may be allowed on the active area only when accompanied by a site representative.

8.1.2 Traffic Control

Public access to the facility will be provided via the entrance road from SH56. Signs will be located along the entrance road directing traffic to the scalehouse. The scale attendant will restrict site access to authorized vehicles and direct these vehicles appropriately. Waste hauling vehicles will be directed to appropriate fill areas by signs located along the landfill haul road and access road. These vehicles will deposit their loads and depart the site. Private, commercial, or public solid waste vehicles will not be allowed access to any areas other than the active portion of the landfill. Site personnel will provide traffic directions as necessary to facilitate safe movement of vehicles.

Within the site, signs will be placed along the landfill haul road and access road at a frequency adequate for users to be able to understand where disposal areas are, and

which roads are to be used. Roads not being used for access to disposal areas will be blocked or otherwise marked for no entry.

8.1.3 Inspection and Maintenance

The perimeter fence and gates will be inspected twice monthly. Refer to Section 8.26 for a site inspection and maintenance schedule. Maintenance will be performed as necessary. Should a breach be detected during inspection or at any other time, every effort will be made to make repairs within eight hours of detection. Notification is not required if permanent repair is made within eight hours. Should repair require more than eight hours, the TCEQ region office and any local pollution agency with jurisdiction that has requested to be notified will be notified of the breach within 24 hours of detection. Temporary repair will be performed within 24 hours of detection and permanently repaired within the time specified to the region office following notification.

8.2 Unloading of Waste

The landfill is authorized to receive Type I municipal solid waste, special wastes allowable under §330.171, and industrial wastes allowable under §330.173. The categories of wastes that are prohibited at this site by state and federal regulations are discussed in Section 5. Special and industrial wastes will not be handled at this landfill, except in accordance with TCEQ regulations and Sections 8.21 and 8.22. Wastes generated by the facility will be processed or disposed of at an authorized facility.

Trained personnel will monitor the incoming waste on the trucks at the scalehouse, at the active working face, and all other waste unloading areas. Trained personnel at the active working face will be on duty during waste acceptance hours to observe waste unloading. Trained personnel will be on duty at the large item staging area, reusable materials staging area, citizen's convenience center, woodwaste/brush mulching area and when waste is unloaded in these areas.

Trained personnel at the active working face will have the authority and responsibility to reject loads which contain prohibited wastes with approval of the landfill manager. These personnel will also have the authority to require the hauler or transporter to remove prohibited waste immediately upon discovery. Should suspected prohibited waste be identified, the working face personnel will immediately notify the landfill manager. The landfill manager may direct staff to remove or manage prohibited waste appropriately, should the responsible hauler or transporter not be identified.

Solid waste unloading will be controlled to prevent disposal in locations other than those specified by site management. Any waste deposited in an unauthorized area will be promptly removed and disposed of properly at the active working face. Control will also be used to confine the working face to a minimum width consistent with the rate of incoming waste while allowing for safe and efficient operation.

A maximum of two working faces may be used during any specific time period, but typically one working face will be used except during inclement weather. The two active working faces include two working faces for disposal of municipal solid waste. The size

of the working faces will be limited by the availability and capacity of site equipment to place cover soil, and the location of soil stockpiles, including those adjacent to the working face.

The large item staging area for large items and white goods may be provided near the active working face or may be provided near the citizen's convenience center. Control will be used to confine the large item staging area to an area consistent with the rate of incoming large items and white goods while allowing for safe and efficient operation. The large item staging area is further discussed in Section 8.9 and Section 8.25.1.

The citizen's convenience center for waste drop-off will be located within the site entrance facilities. The citizen's convenience area will include roll-off containers for waste and recycled goods and an area for large items/white goods. Control will be used to confine this area to a minimum area consistent with the rate of incoming waste while allowing for safe and efficient operation. The citizen convenience area is further discussed in Section 8.25.3.

Any prohibited waste that is not discovered until after it is unloaded shall be returned to the vehicle that delivered the waste. The generator shall be responsible for the proper transportation and disposal of this rejected waste. An effort shall first be made to identify the entity that deposited the prohibited waste and have them return to the site and properly transport and dispose of the waste. If the transporter of the prohibited waste cannot be located or refuses to remove the prohibited waste from the site, facility personnel will properly manage the prohibited waste and arrange for its off-site disposal at an authorized facility. A record of unauthorized waste removal will be maintained in the site operating record.

Signs with directional arrows and portable traffic barricades will help to restrict traffic to designated disposal locations. Signs will be placed along the access route to the current disposal area or other designated disposal areas that may be established. In addition, rules for waste disposal and prohibited waste will be prominently displayed on signs at the site entrance.

8.3 Hours of Operation

TASWA DRF is authorized to accept waste from public and private haulers 24 hours per day, Monday through Friday and until 5:00 p.m. on Saturday (from 12:01 a.m. Monday to 5:00 p.m. Saturday). The site is closed on Sunday. The TASWA DRF is authorized for site operations 24 hours per day, 7 days per week. Site operations include construction, earthmoving, monitoring, transportation of construction materials, heavy equipment operation, and other non-waste acceptance operations. TASWA DRF may be open other hours, as may be required to provide solid waste disposal services for special events, inclement weather, emergencies and other circumstances and the commission's regional offices may allow additional temporary waste acceptance or operating hours to address disasters, other emergency situations, or other unforeseen circumstances that could result in the disruption of waste management services in the area. The TASWA DRF will notify the TCEQ regional office and will record waste acceptance hours outside of posted hours in the site operating plan.

TASWA DRF provides waste disposal services for individuals, businesses, and communities in Cooke, Grayson, and the surrounding counties. The service area is a wide area with significant haul distances from some of the serviced communities. To better serve those communities, businesses, and customers, expanded operating hours will allow for more efficient waste collection and disposal outside of typical working hours and peak traffic times, and reduce traffic and other impacts to infrastructure.

8.4 Site Signs

A sign will be displayed at the gated entrance to the site. This sign will measure at least four feet by four feet and have lettering of at least three inches in height. The sign will state the name of the site, type of site, hours and days of operation, and the TCEQ permit number. An emergency 24-hour contact phone number and the local emergency fire department phone number will also be included. The emergency contact phone number will reach an individual with the authority to obligate the facility at all times the facility is closed.

8.5 Control of Windblown Solid Waste and Litter

The working face will be maintained and operated in a manner to minimize windblown solid waste. Windblown material and litter will be collected and properly managed to control unhealthy, unsafe, or unsightly conditions by the following methods:

- Waste transportation vehicles using this facility will be required to use adequate covers or other means of containment to secure the loads. The adequacy of covers or containment of incoming wastes will be checked at the scalehouse. A sign will be prominently displayed at the scalehouse stating that all loads shall be properly covered.
- The active working face will be limited to as small an area as practical for the safe operation of the incoming waste hauling vehicles, operation of compaction equipment, and delivery and placement of daily cover soils.
- Daily cover will be applied as frequently as needed, to assist with the control of windblown waste.
- The facility will provide litter control fences, as necessary, at appropriate locations near the working face and elsewhere. The litter control fences will be constructed of wire or plastic mesh screens attached to portable or permanent frames or temporary fences. The litter control fence will be of sufficient height and will be located as close as practical to the active area to control windblown waste and litter.
- Windblown waste and litter along the entrance road, the scalehouse area, within the permit boundary, and that has accumulated along the permit boundary will be collected once a day during facility operations and returned to the active working face. Refer to Section 8.26 for the site inspection and maintenance schedule.

- Should windblown waste or litter escape the facility control measures and cross the permit boundary onto adjacent property, the facility will contact the adjacent property owners to seek permission for litter pick-up.
- Screening barriers such as temporary berms, trees, and visual screening berms may also serve as additional wind breaks.

8.6 Easements and Buffer Zones

8.6.1 Easements

In accordance with §330.141(a) and §330.543(a), solid waste unloading, storage, disposal, or facility operations will not occur within any easement, buffer zone, or right-of-way that crosses the site. No solid waste disposal will occur within 25 feet of the centerline of any utility line or pipeline easement, unless otherwise authorized by the TCEQ. All easements will be clearly marked as specified in Section 8.7. Pipelines and utility easements will be marked with posts extending a minimum of six feet above ground surface at intervals that do not exceed 300 feet.

8.6.2 Buffer Zones

The buffer zone is defined as the area between the permit boundary and the limit of waste disposal activities and solid waste processing activities, unless otherwise authorized. In accordance with §330.543(a), no solid waste unloading, storage, disposal, or processing operations will occur within any easement, buffer zone, or right-of-way that crosses the facility, including the 125-foot buffer zone of the landfill. The buffer zones will provide for safe passage of fire-fighting and other emergency vehicles. Landfill buffer zones are a minimum distance of 125 feet for waste disposal operations.

8.7 Landfill Markers and Benchmark

Landfill markers will be installed to clearly mark significant features as described in §330.143(b). The markers will be posts extending at least six feet above the ground surface. The markers will not be obscured by vegetation and will be placed in sufficient numbers to clearly show the required boundaries. Markers that are removed or destroyed will be replaced within 15 days of their removal or destruction or 15 days following completion of construction activities within the affected area. Landfill markers will be inspected monthly and will be maintained and repaired or replaced within 15 days of discovering a marker does not meet regulatory requirements. The landfill markers will be maintained so that they are visible during operating hours. Refer to Section 8.26 for the site inspection and maintenance schedule. Inspection records will be maintained in the site operating record. Guidelines for type, placement, and color coding of markers are provided in §330.143(b).

The required landfill markers are:

Landfill Markers

Marker	Color	Descriptions
Permit Boundary	Black	The permit boundary markers will be placed at each corner of the site and along each boundary line at intervals no greater than 300 feet. Fencing may be placed within these markers as required.
Buffer Zone	Yellow	The buffer zone markers will be placed along the permit boundary at intervals of 300 feet.
Easements	Green	Easement and right-of-way markers will be placed along the centerline of an easement and along the boundary of a right-of-way at each corner within the site and at the intersection of the site boundary.
Grid System	White	The landfill grid system will encompass at least the area expected to be filled within the next three-year period. Markers will be spaced no greater than 100 feet apart measured along perpendicular lines. Intermediate markers will be installed if necessary to allow visibility from opposite boundaries.
SLER/GLER	Red	The SLER markers will be placed so that all areas for which a SLER has been submitted and approved by the Commission are readily determinable. These markers will be located so that they are not destroyed during operations or until operations extend into the next area and will provide site workers immediate knowledge of the extent of approved disposal areas. The location of the markers will be tied into the landfill grid system and reported on each SLER submitted.
Floodplain	Blue	Not applicable as there is no 100-year floodplain within the permit boundary of the facility.

A permanent benchmark is established within the permit boundary in an area that is readily accessible and will not be used for disposal. The benchmark is a United States Coast and Geodetic Survey benchmark consisting of a survey marker stamped with the elevation and survey date and set in concrete. The location of the permanent benchmark is identified in Part III, Attachment B.

8.8 Materials Along the Route to the Site

Consistent with §330.145, the TASWA DRF will take steps to encourage that vehicles hauling waste to the site are enclosed or provided with a tarpaulin, net, or other means to properly secure the load. The landfill will post signs at the entrance gate and scalehouse notifying haulers of this requirement and will enforce this rule by applying surcharges or other similar measures. The landfill manager may report habitual offenders to local law enforcement officers. The TASWA DRF will provide for the cleanup of waste materials spilled along and within the right-of-way of the regular

delivery routes within two miles of the entrance on SH56 and FM 901 when the facility is in operation. Cleanup of the spilled materials will be performed once per day for the following regular delivery routes:

- SH56 – two miles east of the site entrance and two miles west of the site entrance
- FM 901 North – one mile north of the intersection with SH56

TASWA DRF will consult with officials of TxDOT concerning the cleanup of state highways and right-of-ways consistent with §330.145.

8.9 Disposal of Large Items

An area designated for large items and white goods staging and salvage will be provided near the scalehouse as shown on Part III, Attachment 1B. The large items and white goods include items such as ovens, dishwashers, freezers, air conditioners, and other large items. These items will be recycled or disposed of at the working face to prevent a nuisance and to preclude discharge but will not be staged in excess of 180 days.

Refrigerators, freezers, air conditioning units, or other items containing chlorinated fluorocarbon (CFC) refrigerant will be handled in accordance with 40 CFR §82.156(f).

Items which may contain PCBs will be excluded from waste fill. Procedures for detecting and excluding PCBs are provided in Section 5.

Large items that are not recycled will be disposed of at the working face. Care will be taken during disposal of large items to ensure that: (1) large items and/or brush are excluded from the initial 5 feet of waste placed over the protective cover of a liner, (2) large items are placed such that they do not interfere with continued waste filling, and (3) that other smaller municipal solid waste is placed and compacted around them.

8.10 Odor Management Plan

The TASWA DRF will manage odors associated with waste acceptance and disposal operations, and operation of the storage and processing areas consistent with this Odor Management Plan. This plan addresses sources of odors and includes general instructions to control odors or sources of odors.

Measures to control odors and sources of odors may include, but are not limited to, the following items:

- The facility will accept wastes that may generate odors including stabilized liquid wastes, Type I municipal solid waste, and dead animals. The stabilized liquid wastes are required to pass a paint filter test prior to disposal at the active working face.
- Other sources of odors may include ponded water, decomposition of wastes, leachate, contaminated water, and landfill gas (LFG).

- Wastes that are considered to generate significant odors are usually classified as special wastes. Refer to Section 8.20 for waste disposal procedures for odorous wastes.
- Unloading of these wastes at the active working face will be consistent with procedures established in Section 8.2, which limits the size of the active working face, allowing prompt placement of daily cover or approved alternative daily cover (ADC) over wastes that may produce odors.
- Upon unloading of these wastes at the Citizen's Convenience Center, they will be placed promptly into steel roll-off containers as established in Section 8.2. Wastes collected in these containers will be transported to the active working face for disposal daily.
- Spills of these odor producing wastes will be managed by collecting and transporting these wastes to the active working face for prompt disposal and placement of daily cover.
- Daily cover consisting of a minimum of six inches of soil or approved ADC will be placed over these wastes at the end of the working day consistent with procedures established in Section 8.18.
- Waste that is determined to require additional procedures will be isolated within the active working face and immediately covered with a minimum of three feet of other solid waste or a minimum of two feet of earthen material upon receipt. Additional daily cover soil will be placed if needed.
- Sludges that pass the paint filter test may be mixed with other absorptive wastes to minimize odors. Waste with strong odors may be placed at the active working face in a manner that allows immediate cover placement.
- Ponded water at the site will be controlled as detailed in Section 8. Odors will be eliminated through removal of ponded water and regrading of areas consistent with Section 8.1.
- Leachate and contaminated water will be managed in accordance with Part III, Attachment D6. Leachate will be transferred from the leachate collection system either directly to an enclosed liquid transfer vehicle or an on-site enclosed leachate storage tank(s). Leachate may also be recirculated in accordance with the leachate and contaminated water plan.
- Landfill gas will be managed and removed in accordance with Part III, Attachment G. Odor reduction may be achieved by adjustments to the existing gas extraction system or by the installation of additional gas extraction wells within the landfill footprint.

8.11 Disease Vector Control

The need for vector control (control of rodents, flies, mosquitoes, birds, etc.) will be minimized through daily site operations. Activities designed to control on-site populations of disease vectors include minimization of the size of the active working face; placement of daily, intermediate, and final cover; adherence to the ponded water plan; and following the detailed procedures described in this SOP. The TASWA DRF will conduct inspections as required by Section 8.26 to observe waste disposal operations and to remediate areas that may be conducive to insects and rodents. These areas will be promptly addressed in accordance with procedures established in this SOP. Should daily operations not control vectors, a licensed professional will apply pesticides to ensure that proper chemicals are used and that they are properly applied.

8.12 Site Access Roads

The TASWA DRF has constructed a paved entrance road from SH56 to the scalehouse for waste hauling vehicles, operating personnel, and visitors. In addition, an all-weather access road has been constructed from the scalehouse to the active disposal area. Other internal landfill roads will be constructed with a crushed-stone surface or other suitable material. The paved entrance and all-weather access road and the crushed-stone surfaced internal roads will provide mud control for the waste hauling vehicles prior to exiting the site and returning to public access roads. It is not anticipated that mud or other debris will be tracked onto SH56 given its all-weather surface. Should mud or other associated debris be tracked onto SH56, the material will be removed daily.

The landfill haul roads, and access roads will be maintained in a reasonably dust-free condition by periodic spraying from a water truck. Grading equipment will be used weekly or as needed to control or remove mud accumulations on internal roads including the entrance road. Stockpiles of crushed stone, concrete rubble, masonry demolition debris, or other similar material will be available for use in maintaining passable internal access roads including regrading to minimize depressions, ruts, and potholes. The site entrance road, landfill haul road, and access roads will be maintained in a clean and safe condition. Litter and debris will be picked up daily and returned to the active working face. Refer to Section 8.26 for site inspection and maintenance schedule.

8.13 Salvaging and Scavenging

Salvaging will not be allowed to interfere with prompt sanitary disposal of solid waste or to create public health nuisances. Salvaged materials will be considered as potential recycled materials. Salvaged items will be removed from the site on an as-needed basis but will not be stored in excess of 180 days, to prevent the items from becoming a nuisance, to preclude the discharge of pollutants from the area, and to prevent an excessive accumulation of the material at the site. Special wastes received at the site will not be salvaged. Pesticide, fungicide, rodenticide, or herbicide containers will not be salvaged unless they are salvaged through a state-supported recycling program. Scavenging is the uncontrolled and unauthorized removal of materials at any point in the solid waste management system. No scavenging will be allowed at this site. Scavenging

will be prevented through perimeter fencing, site access controls, vector controls, odor controls, daily cover, and monitoring by facility personnel.

8.14 Endangered Species Protection

Development of the landfill shall be conducted to avoid and minimize potential impacts to endangered or threatened species. The facility and the operation of the facility will not result in the destruction or adverse modification of the critical habitat of endangered or threatened species, or cause or contribute to the taking of any endangered or threatened species.

A detailed threatened and endangered species survey and assessment was conducted by a qualified biologist. The survey, assessment, and coordination with the United States Fish and Wildlife Service (USFWS) and the Texas Parks and Wildlife Department (TPWD) regarding the locations and specific data relating to endangered and threatened species in Texas is provided in Part II, Appendix IIE.

8.15 Landfill Gas Control

The control and monitoring of landfill gas for the TASWA DRF will be in accordance with Part III, Attachment G. The Landfill Gas Management Plan (LFGMP) was developed in accordance with §330.371. The LFGMP provides for inclusion of applicable documentation, including monitoring records for landfill gas monitoring probes, in the site operating record, and for submittal to the executive director. Gas monitoring records will be maintained in the site operating record.

8.16 Oil, Gas, and Water Wells

Should any unknown abandoned water, crude oil, or natural gas wells, or other well associated with mineral recovery, be discovered within the permit boundary, the TASWA DRF will provide written notification to the TCEQ executive director as described below. Plugging and abandonment of any well within the waste footprint will be completed as required by the Railroad Commission and/or the Water Development Board.

8.16.1 Water Wells

There is one known water well within the permit boundary but outside the limits of waste disposal of the TASWA DRF. Written certification will be provided to the executive director of the TCEQ within 30 days of the well being capped, plugged, and closed in accordance with all applicable rules and regulations of the TCEQ or other applicable state agency. Should other water wells be discovered during facility development, the TASWA DRF will provide written notification to the executive director of their location and subsequent plugging.

8.16.2 Oil and Gas Wells

Based on a search of oil and gas well locations in the Railroad Commission database, there are two dry holes within the waste footprint and two additional dry holes within the

permit boundary. The two dry holes within the waste footprint have been exposed and capped below the base of the excavation in accordance with Railroad Commission regulations. The Railroad Commission database includes another oil well location within the permit boundary that is not apparent on the ground surface. If crude oil or natural gas wells, dry holes, or other wells associated with mineral recovery are located, the landfill will provide written notification to the TCEQ's executive director of their location within 30 days of their discovery. For crude oil or natural gas wells, or other wells associated with mineral recovery, the landfill manager will provide the executive director of the TCEQ with written certification that all such wells have been properly capped, plugged, and closed in accordance with all applicable rules and regulations of the Railroad Commission of Texas. A copy of the well plugging report to be submitted to the appropriate state agency will also be submitted to the executive director of the TCEQ within 30 days after the well has been plugged. A permit modification will be submitted to the executive director if revisions to the liner installation plan are required as the result of well abandonment.

8.17 Compaction

Compaction of incoming waste provides more efficient use of available space and reduces the amount of settling after the fill is complete. Compaction of the waste will be accomplished by a landfill compactor weighing in excess of 40,000 pounds. The site dozer will be used to compact waste should the compactor be temporarily out of service for repairs. Adequate compaction will be accomplished to minimize future consolidation and settlement and provide for the proper application of intermediate and final cover. The incoming waste will be spread in layers and thoroughly compacted by repeated passages of compaction equipment.

The landfill manager or designee will be present during the placement of the first five feet of waste over the liner system. The landfill manager or designee will verify and document that the initial five feet of waste does not contain large bulky items that could damage the liner system or that cannot be adequately compacted. Waste ballast must be compacted to a density of not less than 1,200 lb/cy or 44 pcf.

The landfill will document that the waste used for ballast has been compacted with repeated passes of a wheeled compactor that weighs in excess of 40,000 pounds. The form to be used by the landfill is provided by TCEQ.

8.18 Landfill Cover

8.18.1 Soil Management

Management of soil for use in and around the landfill area will be an ongoing process at the TASWA DRF. In general, soil for use as daily cover, intermediate cover, final cover, and other uses will be available from areas within the permit boundary. Soil will be obtained from excavation that is ongoing as part of the development of future landfill cells or from other suitable sources. This material may be available near the working face (the exact distance varying daily, weekly, etc., depending on the exact stage of development).

In addition to the available material located within the site, stockpiles of material will be kept available on site. Stockpiles will consist of soil that has not previously come in contact with waste and will be of sufficient volume to provide at least one day's application of six inches of daily cover over the working face. As this stockpile is used, it will be replenished. The soil may also be used in emergency situations for fire control, as discussed in Section 7.

8.18.2 Daily Cover

Daily cover of waste controls disease vectors, windblown waste, odors, fires, scavenging, and promotes runoff from the covered fill area. At least six inches of well-compacted soil cover material that has not been previously mixed with garbage, rubbish, or other solid waste will be placed over all solid waste at the end of each operating day, if alternative daily cover is not used. Refer to Section 8.18.4 for authorized alternative daily cover materials and placement procedures.

To ensure that the daily cover soil will be adequate (i.e., minimize vectors, contaminated stormwater runoff, odors, etc.) the following procedures will be followed:

- The daily cover will be sloped to drain.
- The landfill manager or his designee will document in the Cover Inspection Record, as discussed in Section 8.18.8, where daily cover has been placed and visually inspect during placement that a minimum of six inches (compacted thickness) of daily cover soil has been placed and that no waste is exposed through it.
- Runoff from areas that have intact daily cover is not considered to have come into contact with the working face or leachate and is considered uncontaminated stormwater runoff.

8.18.3 Intermediate Cover

All areas that receive waste and then become inactive for longer than 180 days will be covered with well-compacted earthen material, for a total cover thickness of at least 12 inches. The intermediate cover will be graded to prevent erosion and ponding of water. Six inches of earthen material will be capable of sustaining native plant growth and will be seeded or sodded following its application for erosion control. Plant growth and other erosion control features placed as part of the intermediate cover will be maintained. Runoff from areas that have received intermediate cover is not considered to have come into contact with the active working face or leachate and is considered uncontaminated stormwater runoff.

The landfill manager or his designee will document where intermediate cover has been placed and visually inspect during placement that a minimum of 12 inches (compacted thickness) of intermediate cover soil has been placed. The landfill will document when intermediate cover is being placed, the intermediate cover placement area and indicate that the landfill manager or designee has visually verified the thickness and condition in the Cover Inspection Record as discussed in Section 8.18.8.

8.18.4 Alternative Daily Cover

The TASWA DRF plans to use alternate daily cover material (ADC) in the future. Before a specific ADC is used at the site, the operator will seek authorization from the TCEQ.

8.18.5 Temporary Waiver

The TASWA DRF does not anticipate requesting a waiver from the cover requirements of §330.165(a), (c), and (d) due to extreme climatic conditions. Should the landfill decide to request a temporary waiver due to extreme seasonal climatic conditions, the landfill will request a temporary waiver in accordance with §330.165(e).

8.18.6 Final Cover

Final cover placement over individual areas will be in accordance with Part III, Attachment H and will permit ongoing landfilling operations to continue until the time of final closure. Surface water will be managed throughout the active life of the site to minimize infiltration into the filled areas and to minimize contact with solid waste. Erosion of final cover will be repaired promptly by restoring the cover material, grading, compacting, and seeding it as necessary. Such periodic inspections and restorations are required during the entire operational life and for the postclosure maintenance period. Refer to Section 8.26 for a site inspection and maintenance schedule.

In general, final cover placement over completed portions of the site will consist of the following steps:

- Survey controls will be implemented to control the filling of solid waste to the bottom level of the final cover layer elevation.
- The final cover system layers will be constructed. Testing of the various components of the final cover system will be performed in accordance with Part III, Attachment D8.
- A final cover certification report complete with an as-built survey will be prepared by an independent registered professional engineer and submitted to the TCEQ for approval.
- The TCEQ approved final cover certification report will be maintained in the site operating record, and the cover inspection record, as described in Section 8.18.8, will be updated to reflect the area where final cover has been placed. The TCEQ region office will also be notified that final cover placement has occurred at the site.

8.18.7 Erosion of Cover

Erosion gullies or washed-out areas of the intermediate or final cover, which are deep enough to jeopardize the intermediate or final cover, will be repaired within five days of detection unless the commission's regional office approves otherwise, based on the extent of the damage requiring more time to repair or the repairs are delayed because of

weather conditions. Repair of final cover includes restoring cover, grading, compacting, and seeding as required. Documentation of weather delays for the repairs will be included in the cover inspection record. Weekly inspections and restorations are required for the active life of the landfill. Refer to Section 8.26 for the site inspection and maintenance schedule. Documentation of inspections, detection of erosion, and completion of repairs are required in accordance with Section 8.18.8.

Postclosure care inspection and repair procedures of the final cover are outlined in Part III, Attachment I.

8.18.8 Cover Inspection Record

Throughout the landfill operation, a cover inspection record will be maintained and be readily available for inspection in accordance with §330.165(h). For daily cover, intermediate cover, and alternative daily cover, the record will specify the date cover was accomplished (no exposed waste), area covered (by use of the grid system), how it was placed, and when it was completed. For final cover, the record will show the final cover area completed, date cover was applied, and thickness of final cover. The final cover certification report for each area will be referenced in the record. Each entry in the record will be certified by the signature or initials of the landfill manager or designee that the work was accomplished as stated in the record. The cover inspection record will document inspections required under §330.165(g) including findings, and corrective action taken.

8.19 Ponded Water

The TASWA DRF will prevent ponding of water over areas that have received waste through site operations including grading and maintenance. The facility will prevent ponding of water within the storage and processing facilities through operational requirements for each of these facilities. The Ponded Water Plan provides direction to the landfill operations for the prevention and elimination of ponded water. The Ponded Water Plan follows:

- Daily cover, intermediate cover, and final cover will be placed in accordance with requirements established in Section 8.18.
- The surface of areas that have received waste and landfill cover will be inspected consistent with Section 8.18 and Section 8.26.
- Site grading and maintenance will minimize the ponding of water over areas containing waste.
- Should ponding of water occur, the depressions will be filled in and regraded within seven days of the occurrence, weather permitting. Landfill cover will be repaired consistent with procedures specified in Section 8.18.

- Diversion berms and containment berms are constructed and maintained at the active working face to minimize contaminated water within the active working face in accordance with Part III, Attachment D6.
- Ponded water will be minimized and removed from within the storage and processing facilities in accordance with the design and operational procedures provided in Part III, Attachment B for each of these facilities.
- If the ponded water has come into contact with waste, or waste contaminated soils, it will be treated as contaminated water and handled in accordance with Part III, Attachment D6.

8.20 Disposal of Special Wastes

Special wastes, as defined in §330.3, may be accepted for disposal at the facility in accordance with §330.171(b) and (c).

As specified in §330.171(b)(2), requests for approval to accept special wastes must be submitted by the generator to the TCEQ executive director or the TASWA DRF. The request must include the following:

- A complete description of the chemical and physical characteristics of each waste and the quantity and rate at which each waste is produced and/or the expected frequency of disposal, including a statement if waste is or is not a Class I industrial waste as defined in §330.3.
- An operational plan containing the proposed procedures for handling each waste and listing required protective equipment for operating personnel and onsite emergency equipment.
- A contingency plan outlining responsibility for containment and cleanup of any accidental spills occurring during the delivery and/or disposal operation.

The approval for acceptance and disposal of special wastes at the TASWA DRF will be waste-specific consistent with §330.171(b)(1). The executive director may authorize the receipt of special waste. The landfill is not required to accept the waste.

The following special wastes may be accepted at the facility without prior written authorization in accordance with §330.171(c).

8.20.1 Sludges

Stabilized sludges, grease trap waste, grit trap waste or liquid waste from municipal sources will be accepted if the material has been treated or processed, and has passed the paint filter test in accordance with Test Method 9095 Paint Filter Liquids Test. The material must also be certified to contain no free liquid, as prescribed in §330.171(c)(7). Typically, WWTP sludges will be tested at the waste water treatment plant. Material that passes the paint filter test will be allowed to proceed to the working face. Material that fails the paint filter test will be rejected and sent back to the generator.

8.20.2 Dead Animals

The site may receive dead animals or slaughterhouse wastes that are delivered to the site independent of other wastes. Dead animals and slaughterhouse wastes will be buried and covered with a minimum of 3 feet of other solid wastes or a minimum of 2 feet of earthen material immediately upon arrival in accordance with §330.171(c)(2).

8.20.3 Empty Containers

Empty containers, which have been used for pesticides, herbicides, fungicides, or rodenticides, may be accepted and disposed of in accordance with 30 TAC §330.171(c)(5). Empty containers will be disposed if they have been triple rinsed prior to receipt, rendered unusable prior to receipt, and covered by the end of the same working day with solid waste or daily cover.

8.20.4 Nonregulated Asbestos-Containing Materials

Non-regulated asbestos-containing materials (non-RACM) may be accepted for disposal provided the wastes are placed on the active working face and covered in accordance with §330.171(c)(4) and Section 8.18. Under no circumstances shall any material containing non-RACM be placed on any surface or roadway which is subject to vehicular traffic or disposed of by any other means by which the material could be crumbled into a friable state.

8.20.5 Used Oil Filters

Used oil filters from internal combustion engines must not be intentionally and knowingly accepted for disposal unless conditions are met in accordance with 330.171(d).

8.20.6 Regulated Asbestos-Containing Materials

Regulated asbestos-containing materials (RACM) may not be accepted for disposal.

8.21 Disposal of Industrial Waste

Industrial waste is defined by §330.3 as solid waste resulting from or incidental to any process of industry or manufacturing, or mining or agricultural operations. Class 2 and Class 3 industrial solid wastes may be accepted at the facility, provided disposal of these wastes does not interfere with proper operation of the facility. Class 1 industrial solid waste will not be accepted. Refer to Section 5 and Section 8.2 for waste screening procedures.

8.22 Visual Screening of Deposited Waste

Existing topography and vegetation provide natural screening of deposited waste. Visual screening of deposited waste is provided as part of normal waste disposal and cover placement operations and sequence of development. Final cover will be placed as the landfill reaches final contours. As the site is developed, the visual effect of the disposal activities will be minimized through the use of screening provided by fencing, constructed berms, planted vegetation, and natural vegetation located within the buffer zone.

8.23 Leachate and Gas Condensate Recirculation

The TASWA DRF may recirculate leachate and landfill gas condensate in accordance with Part III, Attachment D6. Consistent with Subtitle D regulations, recirculation of leachate will only occur within the active waste fill area over the areas underlain by a Subtitle D liner system. In addition to the above, the following performance standards will govern the application rate of leachate recirculation.

- The rate of leachate recirculation will not exceed the moisture holding capacity of the landfill. For example, leachate will be applied to that no seeps or ponding is observed in the vicinity of the recirculation area.
- Leachate recirculation will not occur immediately before, during, or immediately after rainfall events, or during freezing temperatures that could affect the holding capacity of the waste.
- Leachate recirculation will not occur during high wind events.

Refer to Part III, Attachment D6 for additional information regarding the leachate collection system and leachate recirculation.

8.24 Contaminated Water Discharge

The TASWA DRF will take all steps necessary to control and prevent the discharge of contaminated water from the facility. Should the discharge of contaminated water become necessary, the landfill will obtain specific written authorization from the TCEQ prior to discharge. All water coming in contact with waste or contaminated soils will be treated as contaminated water. Runon and runoff for the 25-year, 24-hour storm event will be controlled following the procedures set forth in Part III, Attachment D6. The landfill will be operated consistent with §330.15(h)(1)-(4) regarding discharge of solid wastes or pollutants into waters of the United States.

8.25 Processing and/or Storage Units Operations

8.25.1 Large Item Staging Area

A staging area for large items and white goods may be provided near the active working face. Large items and white goods include ovens, dishwashers, freezers, air conditioners, and other large items. These items will be recycled every 180 days or less or disposed at the active working face within 180 days of acceptance at the facility. The procedures for the acceptance, storage, processing, and disposal of large items are addressed in Section 8.9.

A staging area for large items and white goods may be provided near the citizen's convenience area. The large items and white goods are transferred into steel roll-off containers for storing until transport to an off-site recycler or disposed of. Surface water runoff will be diverted around the large item staging area by placement of earthen diversion berms. Surface water runoff from the large item storage area will be managed

as contaminated water and contained by placement of earthen containment and diversion berms to preclude discharge from this area. Containment and diversion berms will be placed consistent with Part III, Attachment D6.

8.25.2 Recyclable Materials Staging Area

Inert materials such as brick, concrete, etc., and non-inert materials such as asphalt may be received and staged at the facility for use as roadbase materials for facility access roads and staging areas or erosion control in drainage structures. Asphalt pavement will not be used for erosion control in drainage structures. The size of the stockpiles may vary depending on the amount of inert materials received at any given time. Since the brick and concrete materials are inert, runoff and runoff from rainfall will not be controlled in a special manner for these materials. Since asphalt pavement or asphaltic concrete is not an inert material, it will be managed in a manner that will prevent runoff of contaminated water, discharge of waste, or creation of nuisance conditions. These inert and non-inert materials will continuously be reused for site operations, and there is no time limit on the staging of these materials.

A recyclable materials staging area may be provided for source-separated recyclable materials, including asphalt and other materials.

8.25.3 Citizen's Convenience Center

A citizen's drop-off and recyclable area is provided which is separate from the landfill operation. Citizen's drop off boxes and covered storage pads may be provided for household waste, source-separated recyclable materials, large items/white goods, batteries, used oil and oil filters, scrap metal, and whole tires. Used oil and oil filters are stored in leakproof, durable containers with secondary containment such as prefabricated secondary containment, plastic liners, concrete vaults, or other suitable containment designed for the safe handling of used oil and oil filters. The containers for used oil and oil filter storage will be located to minimize potential for damage due to vehicle or equipment traffic. Should an oil spill occur, the procedures identified in the facility's Stormwater Pollution Prevention Plan (SWPPP) will be implemented to contain and clean up a spill. Tires will be staged in enclosed, lockable trailers and no more than 2,000 tires will be on-site at any time. The TASWA DRF will provide a sufficient number of drop-off boxes for the citizen's drop-off and recyclable area consistent with the amount of incoming waste/recyclables. A sign will be displayed at the scalehouse which states who may use the citizen's drop-off and recyclable area, what may or may not be accepted, and fees for disposal (if applicable). The maximum time that recyclables will remain at the citizen's drop-off and recyclable area is 180 days. Supervision of the citizen's drop-off recyclable area will be provided to prevent nuisance conditions from developing.

Control will be used to confine the citizen's drop-off and recyclable area to a minimum size consistent with the rate of incoming recyclables, while allowing for safe and efficient operation. The large items/white goods staging area is further discussed in Section 8.9.

Signs with directional arrows and portable traffic barricades will help to restrict traffic to designated disposal locations. Signs will be placed along the access route to the current

disposal area or other designated disposal areas that may be established. In addition, rules for waste disposal and prohibited waste will be prominently displayed on signs at the site entrance. Refer to Section 5 for additional waste handling procedures.

8.25.4 Woodwaste/Brush Mulching Area

Source separated yard trimmings, clean wood materials, and vegetative material may be directed to the woodwaste/brush mulching area. The woodwaste/brush mulching area will be located within the waste footprint and will process yard trimmings, clean wood materials and vegetative materials, which will include trees and brush, into mulch after visual inspection. The resulting wood chips and mulch will only be used on-site and will be staged in the processing area for a maximum time of 60 days after being processed. The average length of time that wood chips and mulch is 30 days after being processed. The resulting wood chips and mulch will be staged in small piles within the processing area so as not to result in litter and will be managed to prevent fire, safety, or health hazards in accordance with 30 TAC §330.209(a).

8.26 Site Inspection and Maintenance Schedule

Item	Task	Schedule	Inspector	Type of Inspection
Fence/Gate	Inspect perimeter fence and gate for damage, gaps, intrusions, and the like. Make repairs if necessary.	Twice per month (An unofficial inspection of the perimeter fence and gate will also be conducted while policing for windblown waste, but the official detailed inspection of the perimeter fence and gate will be conducted twice per month).	Landfill Manager or Designee	Document in the Site Operating Record
Windblown Waste	Police working face area, wind fences, access roads, entrance area, and perimeter fence for loose trash. Clean up as necessary.	Daily	Landfill Manager or Designee	Document in the Site Operating Record
Waste Spilled on Route to the Site	Police entrance area and all roads for at least 2 miles in either direction of site entrance for loose trash. Clean up as necessary.	Daily	Landfill Manager or Designee	Document in the Site Operating Record
Mud Removal	Inspect entrance road and SH56 for mud or other debris during wet weather. Remove mud and other debris.	Daily during wet weather	Landfill Manager or Designee	Document in the Site Operating Record
Landfill Markers	Inspect all landfill markers for damage, color coding and general location. Correct or replace damaged markers within 15 days of discovery.	Monthly	Landfill Manager or Designee	Document in the Site Operating Record
Site Access Road	Inspect site access road for damage from vehicle traffic, erosion, or excessive mud accumulation. Maintain as needed with crushed rock or stone. Grading equipment will be used at least once per week to control or remove mud accumulations on roads as well as minimize depressions, ruts, and potholes.	Weekly – more often during wet weather or extended dry weather periods. Monthly regrading or more frequently in wet weather.	Landfill Manager or Designee	Document in the Site Operating Record
Daily Cover	Inspect for proper placement, thickness, and compaction. Correct problems as needed.	Daily at the active face. All daily cover areas will be inspected daily and after each rainfall event.	Landfill Manager or Designee	Document in the Site Operating Record

8.26 Site Inspection and Maintenance Schedule – Continued

Item	Task	Schedule	Inspector	Type of Inspection
Intermediate Cover	Inspect for proper placement, thickness, erosion, compaction, and for presence of waste or other contamination. Correct problems as needed.	Weekly and after each rainfall event of 0.5 inches or more. Repair erosion within five days of detection, weather permitting.	Landfill Manager or Designee	Document in the Site Operating Record
Final Cover	Inspect for proper placement, thickness, compaction, slope, settlement, and erosion. Maintenance will be ongoing throughout postclosure care period. Correct problems as needed.	Weekly and after each rainfall event of 0.5 inch or more. Repair erosion within five days of detection, weather permitting.	Landfill Manager or Designee	Document in the Site Operating Record
Leachate	Record depth of leachate in sump, as required.	Monthly	Landfill Manager or Designee	Document in the Site Operating Record
Ponded Water	Inspect daily cover, intermediate cover, and final cover areas for potential areas that may pond water. Regrade as required. Remove ponded water over intermediate and final cover areas. Contaminated ponded water removed in accordance with Attachment D6 – Leachate and Contaminated Water Management Plan.	Daily at active face and daily cover areas. Weekly for intermediate and final cover areas. Remove ponded water within seven days of occurrence, weather permitting.	Landfill Manager or Designee	Document in the Site Operating Record

**APPENDIX IVA
LOAD INSPECTION REPORT**

APPENDIX IVA

LOAD INSPECTION REPORT

Date and Time of Inspection: _____

Inspector's Name: _____

Name of Hauling Company: _____ Phone Number: _____

Address: _____ City: _____ State: _____ Zip: _____

Driver's Name: _____ Vehicle License Number: _____

Type of Vehicle: _____ (e.g., roll-off, front loader, dump truck)

Size of Load, yards: _____ Sources of Wastes: _____

LOAD CONTENTS

Waste	Est. % by Vol.	Waste	Est. % by Vol.
Household wastes		Yard waste, brush, stumps	
Wood		Containers	
Metal		Bulk liquids	
Paper, cardboard		Powders, dusts	
Plastic, rubber, glass		Soil	

PROHIBITED WASTE INDICATORS

	YES	NO
Labeled hazardous waste		
Batteries		
Oil		
Medical		
Radioactive		
Ashes		
Soils		
Odors, unusual		
Colors, unusual		
Heat, excessive		
Smoke		

INSPECTION RESULTS

Prohibited wastes identified? _____

Further action required? (e.g., none, lab tests, notification) _____

Samples sent to lab? _____ Lab Name: _____ Phone: _____

Tests requested: _____

Driver Signature

Load Inspector Signature

**APPENDIX IVB
FIRE PROTECTION SOILS CALCULATIONS**

Fire Protection Soil Calculations

The working area cannot be larger than is able to be covered by 6" of soil within 1 hour.

The maximum working area is determined by:

- Available equipment to haul and spread soil
- Available soil in borrow source and in adjacent stockpiles

Table 4-1 of the SOP provides a list of the equipment dedicated to the TASWA DRF.

The following tables provide the production, transport, and application rates for the equipment listed in Table 4-1.

Note: The precision of the calculations is for demonstration purposes only and is not meant to imply exact conditions in the field.

Table 1. Load time for soil loading equipment.

Equipment	Cubic Yards per Load	Loads per Hour	Time per Load	Cubic Yards per Hour
Excavator	3	240	0.25 min	720 ¹

Table 2. Load, transport, and unload capacity for soil transport equipment.

Equipment	Cubic Yards per Load	Load Time	Transport Time (2500 ft at 15 mph, x2 for round trip)	Unload Time	Total Load, Transport, and Unload Time	Loads per Hour	Cubic Yards Delivered per Hour
Haul Truck	16	1.33 min (loaded by excavator)	3.8 min	1 min	6.13 min	9.8	157
Scraper	20	4.9 min (self-loaded)	3.8 min	1 min	9.7 min	6.19	124

Table 3. Spreading capacity for soil spreading equipment.

Equipment	Spreading Rate (cubic yards per hour)	Area that Can Be Covered 6 Inches Deep in 1 Hour	Nominal Working Face Dimensions (square)	Nominal Working Face Dimensions (rectangle 2:1 width:depth)
Dozer	600 ²	32,400 sq ft	180 ft x 180 ft	254.6 ft x 127.3 ft
Compactor	600 ²	32,400 sq ft	180 ft x 180 ft	254.6 ft x 127.3 ft

Fire Protection Soil Calculations (Continued)

Table 4. Example scenarios of equipment capacity and soil needs for covering working face within 1 hour. Other combinations achieving equivalent capacity may be used.

Working Face Dimensions (width x depth, ft)	Working Face Area (sq ft)	Volume of Soil to Cover 6 Inches Deep (cu yd)	Transport Equipment	Volume of Soil Transport from Borrow Source within 2500 ft (cu yd)	Volume of Soil Stockpile at Working Face (cu yd)	Equipment for Spreading Soil within 1 Hour
150 x 150	22,500	417	1 Haul Truck	157	260	1 Dozer or 1 Compactor
250 x 150	37,500	694	1 Haul Truck and 1 Scraper	281	413	1 Dozer and 1 Compactor
350 x 200	70,000	1,296	2 Haul Trucks and 1 Scraper	438	858	2 Dozers and 1 Compactor
450 x 200	90,000	1,667	2 Haul Trucks and 2 Scrapers	562	1,105	2 Dozers and 1 Compactor
550 x 250	137,500	2,546	3 Haul Trucks and 2 Scrapers	719	1,827	2 Dozers and 3 Compactors

¹ One excavator can produce enough soil to load a haul truck 45 times per hour (up to 4 haul trucks).

² Low end of range published in *Excavation Handbook*, Horace C. Church 1991.