



Guidelines for Operation and Maintenance of Dams in Texas



TEXAS COMMISSION ON
ENVIRONMENTAL QUALITY

Contents

Introduction	3
Welcome to Dam Safety	3
Introduction to Dams	3
Hazards, Risks, Failures	3
Developing a Dam-Safety Program	3
Inspection Guidelines	4
Instrumentation and Monitoring Guidelines	4
Maintenance Guidelines	4
Emergency Action Plan Guidelines	5
Operation Plan Guidelines	5
Measures to Reduce the Consequences of Dam Failure	5
Chapter 1. An Approach to Dam Safety	6
1.0. General	6
1.1. Urgency for Safety	6
1.2. Dam Ownership and Safety	6
1.3. The Increasing Complexity of the Dam-Safety Problem	6
1.4. Role of the TCEQ	6
1.5. Role of the Consultant in Dam Safety	7
1.6. Role of the Dam Owner in Dam Safety	7
Chapter 2. Introduction to Dams	9
2.0. General	9
2.1. The Watershed System	9
2.2. Types of Dams	9
2.3. Water-Retention Ability	11
2.4. Release of Water	12
Chapter 3. Hazards, Risks, Failures	13
3.0. General	13
3.1. Hazards as Sources of Risk	13
3.2. Site-Specific Structural Risk	16
3.3. Sources of Dam Failure	16
Chapter 4. Developing a Safety Program	19
4.0. Objectives	19
4.1. Guidelines for Assessing Existing Conditions	19
4.2. Procedural Guidelines—A Source Book	20
4.3. Documenting the Safety Program	20
Chapter 5. Inspection Guidelines	21
5.0. Introduction	21
5.1. Organizing for Inspection	21
5.2. Embankment Dams and Structures	23
5.3. Concrete Dams and Structures	25
5.4. Spillways	26
5.5. Inlets, Outlets, and Drains	29
5.6. General Areas	31

Chapter 6. Instrumentation and Monitoring Guidelines 57

6.0. General 57

6.1. Reasons for Instrumentation 57

6.2. Instrument Types and Usage 58

6.3. Automated Data-Acquisition Systems 63

6.4. Frequency of Monitoring 64

Chapter 7. Maintenance Guidelines 65

7.0. General 65

7.1. Maintenance Priorities 65

7.2. Specific Maintenance Items 65

Chapter 8. Guidelines for an Emergency Action Plan 73

8.0. General 73

8.1. Contents of Guidelines 73

8.2. Title Page 73

8.3. Table of Contents 73

8.4. Purpose 73

8.5. Description of Project 73

8.6. Notification Flowchart 74

8.7. Emergency Detection, Evaluation, and Classifications 74

8.8. Responsibilities 74

8.9. Preparedness 75

8.10. Inundation Maps 75

8.11. Implementation 75

Chapter 9. Guidelines for Operations 78

9.0. General 78

9.1. Plan Guidelines 78

9.2. Schedule of Routine Tasks 79

9.3. Record Keeping 79

Chapter 10. Reducing the Consequences of Dam Failure 81

10.0. Supplements to a Dam-Safety Program 81

10.1. Liability 81

10.2. Measures to Reduce the Consequences of Dam Failure 82

Appendix A. Inspection Report 85

Appendix B. Report Forms 89

**Appendix C. Texas Parks and Wildlife’s
Recommendations on Herbicide Use to
Control Vegetation on Earthen Dams 91**

Glossary 95

Selected Bibliography 101

Introduction

Welcome to Dam Safety

The need for dam safety is urgent. Across the United States, thousands of dams are now in place, with many more built each year. Dams—essential elements of the national infrastructure—supply water for households and businesses and cooling water for power plants, offer opportunities for recreation, and help control floods. Should a dam fail, many lives and many dollars' worth of property are at risk. The legal and moral responsibility for dam safety rests with you—the dam owner.

Existing dams are aging and new ones are being built in hazardous areas. At the same time, development continues in potential inundation zones downstream. More people are at risk from dam failure than ever, despite better engineering and construction methods, and continued deaths and property losses from dam failures are to be expected.

Society and individuals alike may profit from dam operations. Dam ownership, however, is neither justified nor effective if one cannot assure the safety of citizens and property. The costs of dam safety are small in comparison to the consequences following a dam failure, particularly in today's litigious society. Liability due to dam failure can easily offset years of profitability.

You can directly influence the safety of a dam by developing a safety program

which includes inspection, monitoring through instrumentation, maintenance of the structure, and proactive emergency planning. A high-quality safety program is attuned to the dam structure and its immediate environment and depends on the owner's knowledge of the dam and how it works.

Introduction to Dams

Dams may either be human-built or exist because of natural causes, such as landslides or glacial deposition. The majority of dams are human structures constructed of earthfill or concrete. It is important that you, as a dam owner, be aware of the different types of dams, their essential components and how those components function, and important physical conditions likely to influence them.

Hazards, Risk, Failures

Present national statistics on losses from dam failure fully justify the need for you to better understand the risks involved with dam ownership, the kinds of hazards that promote these risks, and the reasons dams fail. Risk is high because people have been allowed to settle below dams in potential inundation zones, and new dams are being built at sites that are less than ideal geologically.

Other risks include natural phenomena such as floods, earthquakes, and landslides. These hazards threaten dam structures and their surroundings. Floods that exceed the capacity of a dam's spillway and then erode the dam or abutments are particularly hazardous, as is seismic activity that may cause cracking or seepage. Similarly, debris from landslides may block a dam's spillway and cause an overflow wave that erodes the abutments and ultimately weakens the structure.

The three major categories of dam failure are overtopping by flood, foundation defects, and piping. For earthen dams, the major reason for failure has been piping or seepage. For concrete dams, the major reasons for failure have been associated with foundations. Overtopping has been a significant cause of dam failure, primarily where a spillway was inadequate.

Developing a Dam-Safety Program

Recognition of the causes and possible impacts of dam failure points the need for a program to enhance dam safety. Such a program must be based on a safety evaluation to determine a dam's structural and operational condition. The evaluation should identify problems and recommend either remedial repairs, operational restrictions and modifications, or further studies and analyses to determine solutions.

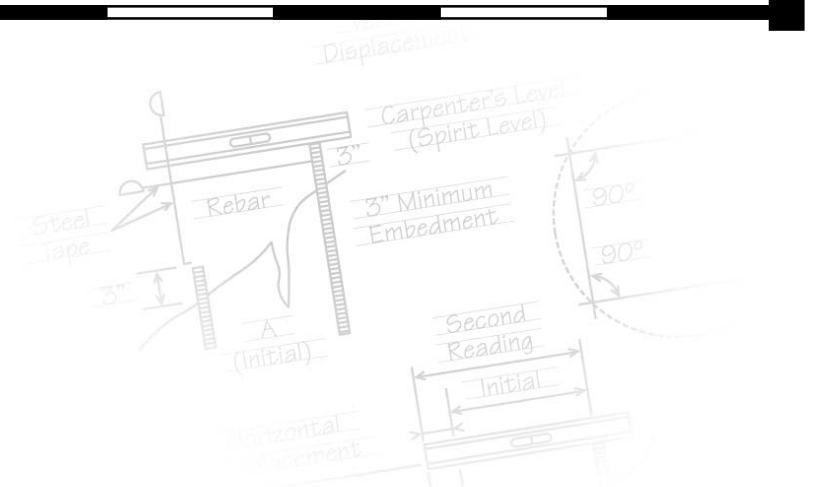

A safety program comprises several components that address the spectrum of possible actions to be taken over the short and long term. Development of a safety program takes place in phases, beginning with collection and review of existing information, proceeding to detailed inspections and analyses, and culminating with formal documentation. Much of the preliminary work can be accomplished by the dam owner with the assistance of state and local public agencies. Professional assistance by qualified engineers and contractors may be required, however, depending upon the number and seriousness of problems identified during the initial assessment.

This manual offers direction on how to increase the safety of a dam and details technical and procedural components of the safety program ; necessary forms appear in the appendixes.

The program of inspection for both the initial and continuing safety evaluations establishes the condition of the dam and gathers the information necessary for determining specific actions regarding repairs, operations, and monitoring. The program is cyclical, recognizing the need for continued vigilance. Emergency action can, it is hoped, be avoided, but a well-thought-out plan of action in case of imminent or actual failure can greatly reduce damage and possible loss of life.

Inspection Guidelines

An effective inspection program is essential to identification of problems and for safe maintenance of a dam. The program should involve three types of inspections: (1) periodic technical inspections; (2) periodic maintenance inspections; and (3) informal observations by project personnel as they operate the dam. Technical inspections involve

specialists familiar with the design and construction of dams and include assessments of structure safety. Maintenance inspections—performed more frequently than technical inspections in order to detect, at an early stage, any detrimental developments in the dam—involve assessment of operational capability as well as structural stability. The third type of inspection is actually a continuing effort by on-site project personnel (dam tenders, powerhouse operators, maintenance personnel) performed in the course of their normal duties.

Instrumentation and Monitoring Guidelines

A dam's instrumentation furnishes data for determining if the structure is functioning as intended and continuing surveillance to warn of any unsafe developments. Monitoring physical phenomena that can lead to a dam failure may draw on a wide spectrum of instruments and procedures ranging from very simple to very complex. Any program of dam- safety instrumentation must involve proper design consistent with other project components. The program must be based on prevailing geotechnical conditions at the dam, and must include consideration of the hydrologic and hydraulic factors present before and after the project is in operation. Instrumentation designed for monitoring potential deficiencies at existing dams must take into account the threat to life and property that the dam presents. Thus, the extent and nature of the instrumentation depends not only on the complexity of the dam and the size of the reservoir, but also on the potential for deaths and property losses downstream.

An instrumentation program should involve instruments and evaluation methods that are as simple and straight-

forward as the project will allow. Moreover, you should make a definite commitment to a continuing monitoring program; if the program is not continuing, the installation of instruments and procedures will be wasted. Obviously, the involvement of qualified personnel in the design, installation, monitoring, and evaluation of an instrumentation system is of prime importance to the success of the program.

Instrumentation and proper monitoring and evaluation are extremely valuable in determining the performance of a dam. Specific information that instrumentation can provide includes:

- warning of a problem (i.e., settlement, movement, seepage, stability)
- definition and analysis of a problem, such as locating areas of concern
- proof that behavior is as expected
- evaluating remedial actions

Maintenance Guidelines

A good maintenance program will protect a dam against deterioration and prolong its life. A poorly maintained dam will deteriorate, and may fail. Nearly all the components of a dam and the materials used for its construction are susceptible to damaging deterioration if not properly maintained. A good maintenance program protects not only you but the general public as well. The cost of a proper maintenance program is small compared to the cost of major repairs or the loss of life and property and resultant litigation. You should develop a basic maintenance program based primarily on systematic and frequent inspections. Inspections, as noted in Chapter 5, should be carried out monthly and after major floods or earthquakes. During each inspection, fill out a checklist of items requiring maintenance.

Emergency Action Plan Guidelines

History has shown that dams sometimes fail and that often these failures cause loss of life, injuries and extensive property damage. You should prepare for this possibility by developing an emergency action plan which provides a systematic means to:

- Identify potential problems that could threaten a dam.
- Determine who would be at risk should a failure occur.
- Expedite effective response actions to prevent failure.
- Develop a notification plan for evacuating people to reduce loss of life and property damage should failure occur.

You are responsible for preparing a plan covering these measures and listing actions that you and operating personnel should take. You should be familiar with the local government officials and agencies responsible for warning and evacuating the public.

It is important that you make full use of others who are concerned with dam safety. Emergency plans will be more effective if they integrate the actions of others who can expedite response. People and organizations with whom you should consult in preparing an emergency action plan include numerous local participants, state and federal agencies.

An essential part of the emergency action plan is a list of agencies and persons to be notified in the event of a potential failure. Possible inclusions for this list should be obtained from and coordinated with local law-enforcement agencies and local disaster emergency services—key institutions that can activate public warning and evacuation procedures or that might be able to assist you, the dam owner, in delaying or preventing failure.

Certain key elements must be included in every notification plan. Information about potential inundation (flooding) areas and travel times for the breach (flood) wave is essential. Inundation maps are especially useful in local warning and evacuation planning, including identifying evacuation routes. Detailed information about identification of inundation areas or the development of maps can be found by contacting the Texas Commission on Environmental Quality.

Operation Plan Guidelines

Establishing an operation procedure or plan calls for detailed:

- data on the physical characteristics of dam and reservoir
- descriptions of dam components
- operating instructions for operable mechanisms
- instructions for inspections
- instrumentation and monitoring guidelines
- guidelines for maintenance
- guidelines for emergency operations
- bibliographic references

Establish a schedule for both day-to-day tasks and tasks performed less frequently throughout the year. The schedule should formalize inspection and maintenance procedures so that even an inexperienced person can determine when a task is to be done.

Measures to Reduce the Consequences of Dam Failure

Liabilities that are determined following a dam failure strongly affect organizations and individuals, govern-

ments and dam owners alike. Establishing liability is the legal means developed by society to recover damages due to a wrong (in this case, lack of dam safety) and represents another perspective on the dam-safety problem. A thorough understanding of this legal process can help you decide the steps necessary to reduce liability.

You can directly and indirectly influence the introduction and use of a variety of other measures that will serve to reduce the consequences of dam failure. For example, insurance against the costs that will accrue after a failure will save you money by spreading costs to multiple dam owners. Some land-use measures instituted by governments represent better means of mitigating future disasters. Restrictions against living in inundation zones radically improve safety. Land-use measures are among the most effective ways to save lives and preserve property over the long term, but such steps are not always acceptable to governments. Thus, given that lives and property are at stake, increasing public awareness and governmental planning are vital measures that also must be considered as ways to reduce the consequences of dam failure.

You can obtain insurance directly and should do so. Other measures discussed here—land use, public awareness, and preparedness planning—are essentially controlled by local governments. You would be wise to encourage actions in the public sector that increase awareness of dam safety issues. Finally, you may also wish to hire private consultants when information needed for prudent decisions exceeds your own expertise.

1

CHAPTER

Chapter 1: An Approach to Dam Safety

1.0 General

This manual is a safety guide for dam owners. The continuing need for dam safety is critical because of the thousands of dams now in place and the many new ones being built each year. Although these dams are essential elements of the national infrastructure, the risks to the public posed by their possible failure are great; a large and growing number of lives and valuable property are at stake. Though many are concerned about dam safety, the legal and moral responsibility essentially rests with the dam owner.

1.1 Urgency for Safety

The critical need for dam safety is clear. World and national statistics on dam failures show an unacceptable record of deaths and property losses. The record for U.S. losses from major dam failures in recent years, shown in Table 1.1 is also discouraging. Actual national losses are much higher than indicated because the statistics shown exclude small dam failures and many combinations of dam failure and natural flooding events—a specific example from Texas is the two dams that failed near Hearne in May 2004. The Johnstown, Pennsylvania, disaster of 1889 is regarded as one of the nation's great catastrophes, and the potential for future similar catastrophes due to dam failure remains strong. Only a cooperative effort in dam safety involving owners and communities can lessen this potential.

1.2 Dam Ownership and Safety

This manual can be applied to dams owned and operated by a wide range of organizations and people, including state and local governments, public and private agencies, and private citizens. Typical reasons for building dams include water storage for human consumption, agricultural production, power generation, flood control, reduction of soil erosion, industrial use, and recreation. Thus, dam owners serve society by meeting important state needs and may also personally profit from dam operations. However, those are not sufficient reasons for building or owning a dam if the owner cannot keep people and property safe in potential inundation zones.

Both financially and morally, successful dam ownership and the maintenance of safety standards go hand in hand. Investment in dam safety should be accepted as an integral part of project costs and not viewed as an expendable item that can be eliminated if a budget becomes tight (Jansen, 1980). The costs of dam safety are small in comparison to those that follow dam failure, particularly in today's litigious society. Liability due to a failure would probably negate years of potential profits. Owning a dam brings many different concerns and possible rewards, but in the end success will largely be measured by a continuing record of safety.

1.3 The Increasing Complexity of the Dam-Safety Problem

As national needs for water intensify and its value increases, more dams are being built. At the same time, many existing dams are reaching or passing their design life spans and, for various reasons, people continue to settle near dams. As builders are forced to use poorer sites for dams, the job of protecting life and property becomes more difficult. Therefore, as dam construction continues and the population grows, exposure of the public to dam-failure hazards increases and the overall safety problem becomes more difficult.

Governments across the nation have shown increasing concern for this problem and have enacted laws, statutes, and regulations that increase the dam owner's responsibility. In most states, including Texas, owners are held strictly liable for losses or damages resulting from dam failure. Concurrently, liability insurance costs have risen rapidly.

1.4 Role of the TCEQ

The Texas Commission on Environmental Quality is responsible for administering state dam-safety laws, which are found in Section 12.052 of the Texas Water Code and Chapter 299 of the Texas Administrative Code.

The staff of the TCEQ has four primary areas of activity in the dam-safety program: (1) safety evaluations of existing dams, (2) review of plans and specifications for dam construction and major

Table 1.1
Loss of Life and Property Damage
From Notable U.S. Dam Failures, 1963-2006

Name & Location of Dam	Date of Failure	Number of Lives Lost	Damages
Mohegan Park, CT	3/63	6	\$3 million.
Little Deer Creek, UT	6/63	1	Summer cabins damaged.
Baldwin Hills, CA	12/63	5	41 houses destroyed, 986 houses damaged, 100 apartment buildings damaged.
Swift, MT	6/64	19	Unknown.
Lower Two Medicine, MT	6/68	9	Unknown.
Lee Lake, MA	3/68	2	6 houses destroyed, 20 houses damaged, 1 manufacturing plant damaged or destroyed.
Buffalo Creek, WV	2/72	125	546 houses destroyed, 538 houses damaged.
Lake "O" Hills, AR	4/72	1	Unknown.
Canyon Lake, SD	6/72	33	Unable to assess damage because dam failure accompanied damage caused by natural flooding.
Bear Wallow, NC	2/76	4	1 house destroyed.
Teton, ID	6/76	11	771 houses destroyed, 3,002 houses damaged, 246 businesses damaged or destroyed.
Laurel Run, PA	7/77	40	6 houses destroyed, 19 houses damaged.
Sandy Run & 5 others, PA	7/77	5	Unknown.
Kelly Barnes, GA	11/77	39	9 houses, 18 house trailers, & 2 college buildings destroyed; 6 houses, 5 college buildings damaged.
Lawn Lake, CO	7/82	3	18 bridges destroyed, 117 businesses & 108 houses damaged. Campgrounds, fisheries, power plant damaged.
D.M.A.D., UT	6/83	1	Unknown.
Nix Lake Dam, TX	3/89	1	Unknown.
Silver Lake, MI	5/03	0	\$102,000,000.
Big Bay Lake, MS	3/04	0	98 houses, 2 churches, fire station, bridge, \$2.2 million
Kaloko Res., HI	3/06	7	Unknown.

Source: Graham, 1983, 2004

rehabilitation work, (3) periodic inspections of construction work on new and existing dams, and (4) review and approval of emergency action plans.

1.5 Role of the Consultant in Dam Safety

A dam is a special kind of structure—simple in concept but with many compli-

cated components. There is no such thing as a standard dam design; furthermore, each dam site is unique. The existence of a dam necessitates the involvement of many specialists to analyze, design, build, inspect, and repair it. This wide variety of consultants will include civil, geotechnical, mechanical, and electrical engineers.

As owner, you should know more about your dam than anyone else. A consultant can advise you on such important items as:

- The overall stability of the dam under normal and flood conditions.
- Any repairs or maintenance needed by the dam and appurtenant works. The consultant should identify the severity of any problems and indicate in what order to repair them.
- Cost estimates for repair work.
- Adequacy of the spillway to pass the design flood.
- An assessment of downstream hazards.
- The dam owner's preparation and procedures to deal with emergency conditions.

Hazardous conditions at the dam should be reported verbally and in writing to the dam owner and the TCEQ. A written report from the owner's consultant is essential for every inspection. It is uncommon that a dam owner has all of the technical skills needed to monitor the condition of the dam. Thus, the role of the consulting engineer is critical in dam safety.

1.6 Role of the Dam Owner in Dam Safety

An owner should be aware of and use both direct and indirect means of achieving dam safety. He can, of course, monitor and work on factors directly in his control (for example, structural integrity), which are detailed below. However, the owner may also seek to influence governmental policy and work for positive change in statutes and laws that affect dam safety (example, zoning laws). Such indirect influence by an owner could contribute significantly to reducing the likelihood and consequences of dam failure and, thus, to overall community safety.

Liability, insurance coverage, and the roles of the state and federal governments should all be well-understood by an owner. In Texas, liability can be imposed upon a

dam owner who fails to maintain, repair, or operate the dam safely and properly. This liability can apply not only to the individual dam owner, but also to any company that possesses the dam, or any person who operates or maintains it. If an unsafe condition existed prior to a new dam owner's term of ownership, the new owner cannot be relieved of liability should the dam fail during this term. Thus, the potential owner must carefully inspect the structural integrity of any dam prior to purchase and then inspect, maintain, and repair it thereafter. The current dam owner has a responsibility to disclose the conditions of the dam before selling the property.

Legally, the dam owner must do what is necessary to avoid injuring

persons or property—this usually applies to circumstances and situations which a reasonable person could anticipate. In order to meet your responsibility to maintain the dam in a reasonable and safe condition, you, the owner, should conduct regular inspections of the dam and maintain or repair deficient items. Regular inspections by qualified professionals are necessary to identify all problems and correcting them.

In addition to being well informed concerning liability, you should have a thorough understanding of your dam's physical and social environment, including knowledge of natural and technological hazards that threaten it, an understanding of the developing human settlement patterns around the dam, and an under-

standing of other events that can lead to structural failure. These indirect means of achieving dam safety are covered in more detail in Chapters 2, 3 and 10.

Owners can also influence the safety of dams in more direct ways. They can and should develop their own safety programs, which should include such important elements as inspection, monitoring through instrumentation, maintenance, emergency action planning, and proper operation. Such programs are directly related to a specific dam's structure and its immediate environment and depend on the owner's knowledge of the dam and how it works. Chapter 2 stresses the need for owner's knowledge about the dam, while Chapters 4 and 9 cover how to develop a safety program.

Chapter 2: Introduction to Dams

2.0 General

The purpose of a dam is to impound (store) water for any of several reasons, e.g., flood control, water supply for humans or livestock, irrigation, energy generation, recreation, or pollution control. This manual primarily concentrates on earthen dams, which constitute the majority of structures in place and under development in Texas.

2.1 The Watershed System

Water from rainfall or snowmelt naturally runs downhill into a stream valley and then into larger streams or other bodies of water. The “watershed system” refers to the drainage process through which rainfall or snowmelt is collected into a particular stream valley during natural runoff (directed by gravity). Dams constructed across such a valley then impound the runoff water and release it at a controlled rate. During periods of high runoff, water stored in the reservoir typically increases, and overflow through a spillway may occur. During periods of low runoff, reservoir levels usually decrease. The owner can normally control the reservoir level to some degree by adjusting the quantity of water released. Downstream from the dam, the stream continues to exist, but because the quantity of

water flowing is normally controlled, very high runoffs (floods) and very low runoffs (drought periods) are avoided.

2.2 Types of Dams

Dams may either be human-built or result from natural phenomena, such as landslides or glacial deposition. The majority of dams are human structures normally constructed of earthfill or concrete. Naturally occurring lakes may also be modified by adding a spillway to allow for safe, efficient release of excess water from the resulting reservoir.

Dam owners should be aware of:

- the different types of dams
- essential components of a dam

- how the components function, and
- important physical conditions likely to affect a dam.

Human-built dams may be classified according to the type of construction materials used, the methods used in construction, their slope or cross-section, the way they resist the forces of the water pressure behind them, the means of controlling seepage, and occasionally, their purpose.

A. Components—The components of a typical dam are illustrated in Figure 2.1. Nearly all dams possess the features shown or variations of those features. Definitions of the terms are given in the Glossary. The various dam components are discussed in greater detail later on.

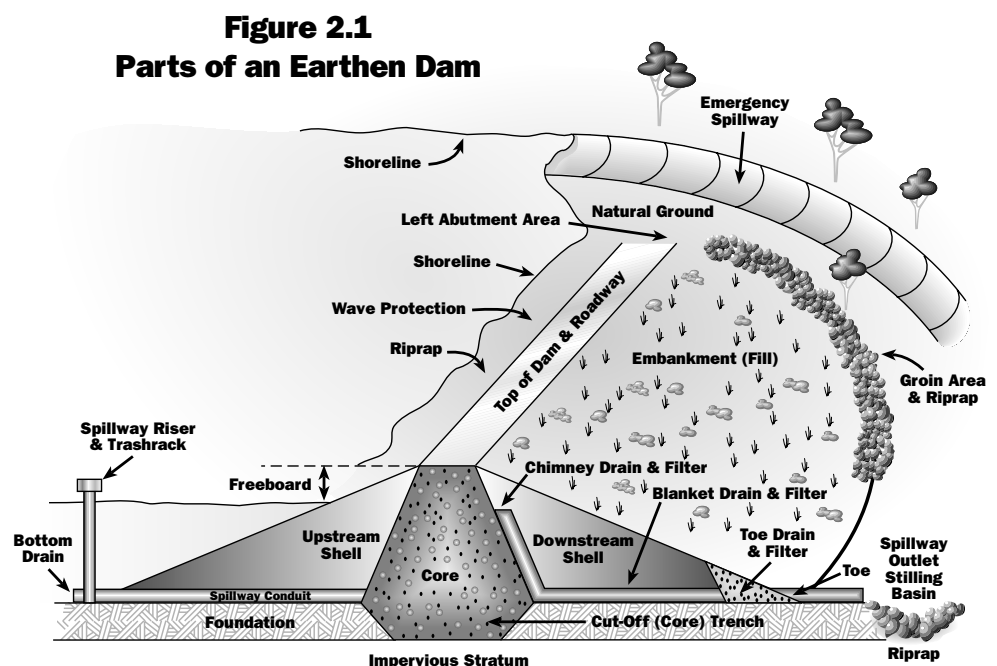

Figure 2.1
Parts of an Earthen Dam

Source: North Carolina Department of Environmental and Natural Resources (1989).

B. Construction Materials— The

materials used for construction of dams include earth, rock, tailings from mining or milling, concrete, masonry, steel, and any combination of these materials.

1. *Embankment Dams*—Embankment dams, the most common type in use today, have the general shape shown in Figure 2.1. Their side slopes typically have a grade of two to one (horizontal to vertical) or flatter. Their capacity for water retention is due to the low permeability of the entire mass (in the case of a homogeneous embankment) or of a zone of low-permeability material (in the case of a zoned embankment dam).

Materials used for embankment dams include natural soil or rock obtained from borrow areas or nearby quarries, or waste materials obtained from mining or milling. If the natural material has a high permeability, then a zone of very-low-permeability material must be included in the dam to retain water.

An embankment dam is termed an “earthfill” or “rockfill” dam depending on whether it is composed mostly of compacted earth or mostly of compacted or dumped pervious rock.

The ability of an embankment dam to resist the hydrostatic pressure caused by reservoir water is primarily the result of the mass, weight, and strength of its materials.

2. *Concrete Dams*—Concrete dams may be categorized into gravity and arch dams according to the designs used to resist the stress due to reservoir water pressure. A concrete gravity dam (shown in Figure 2.2) is the most common form of concrete dam. In it, the mass weight of the concrete and friction resist the reservoir water pressure. A buttress

Figure 2.2
Concrete Gravity Dam

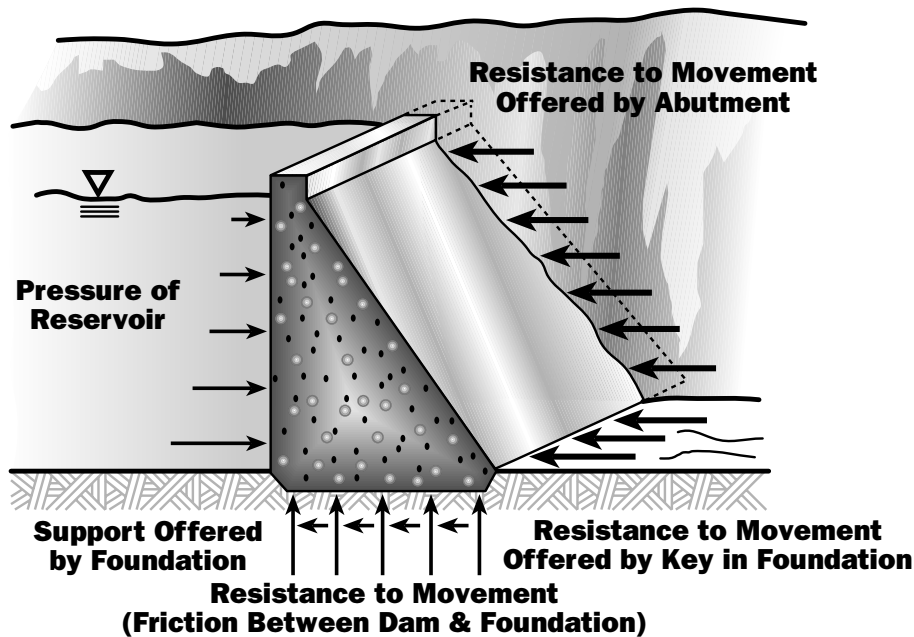

dam is a specific type of gravity dam in which the large mass of concrete is reduced, and the forces are diverted to the dam foundation through vertical or sloping buttresses. Gravity dams are constructed of non-reinforced vertical blocks of concrete with flexible seals in the joints between the blocks.

Concrete arch dams are typically rather thin in cross-section (Figure 2.3). The reservoir water forces acting on an arch dam are carried laterally into the abutments. The shape of the arch may resemble a segment of a circle or an ellipse, and the arch may be curved in the vertical plane as well. Such dams are usually built from a series of thin vertical blocks that are keyed together, with water stops between the blocks. Variations of arch dams include multi-arch dams, in which more than one curved section is used, and arch gravity dams, which combine some features of the two types.

A recently developed method for constructing concrete gravity dams involves the use of a relatively weak concrete mix which is placed and compacted in a manner similar to that used for earthfill dams. Roller-compacted concrete has the advantages of decreased cost and time. In addition, there are no joints where seepage could occur.

3. *Other Types*—Various construction techniques could be used in a single dam. For example, a dam could include an earthen or rockfill embankment as well as a portion made of concrete. In such a case, the concrete section would normally contain the spillway or other outlet works.

A recent design for low-head dams (with a minimal height of water behind the dam) uses inflatable rubber or plastic materials anchored at the bottom by a concrete slab.

Some dams are constructed for special purposes, such as diversion of water, or permit construction of

Figure 2.3
Concrete Arch Dam

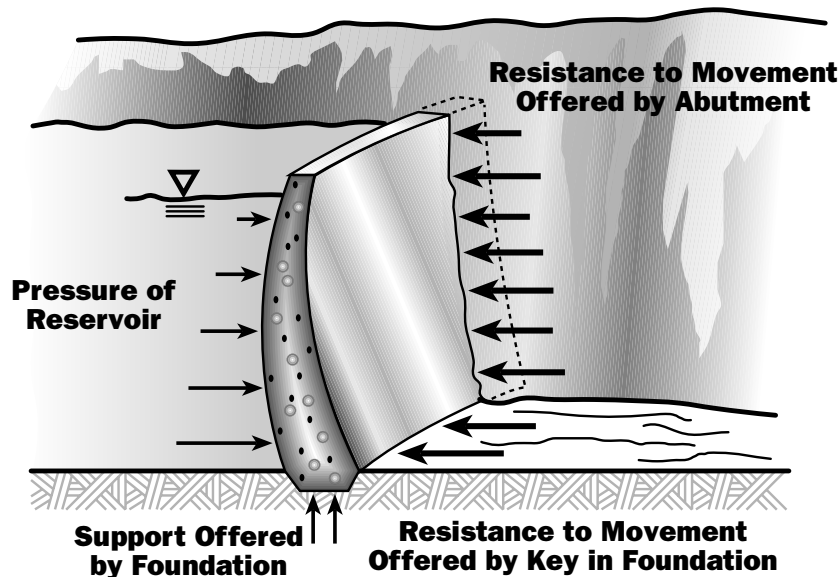

other facilities in river valleys. These dams are called *diversion dams* and *cofferdams*, respectively.

2.3 Water-Retention Ability

Because the purpose of a dam is to retain water effectively and safely, its water-retention ability is of prime importance. Water may pass from the reservoir to the downstream side of a dam by:

- (1) Seeping through the dam.
- (2) Seeping through the abutments.
- (3) Seeping under the dam.
- (4) Overtopping the dam.
- (5) Passing through the outlet works.
- (6) Passing through or over a service (primary) spillway.
- (7) Passing over an emergency spillway.

The first three modes are considered undesirable, particularly if the seepage is not limited in area or volume. Overtopping of an embankment dam is also very undesirable because the embankment material may be eroded away. Additionally, only few concrete dams have been designed to be overtopped. Water nor-

mally leaves a dam by passing through an outlet works or a service spillway; it should pass over an emergency spillway only during periods of very high reservoir levels and high water inflow.

A. Seepage Through a Dam—All embankment dams and most concrete dams allow some seepage. The earth or other material used to construct embankment dams has some permeability, and water under pressure from the reservoir will eventually seep through. However, it is important to control the quantity of seepage by using low-permeability materials in construction and by channeling and restricting the flow so that embankment materials do not erode.

Seepage through a concrete dam is usually minimal and is almost always through joints between blocks, or through cracks or deteriorated concrete which may have developed. Maintenance of these joints and cracks is therefore essential. The seepage water should be collected and channelized, so that its quantity can be measured and erosion minimized.

B. Seepage Around a Dam—Seepage under a dam, through the dam foundation material, or around the ends of a dam through the abutment materials may become a serious problem if the flow is large or of sufficient velocity to cause erosion. Seepage under a dam also creates high hydrostatic uplift (pore-water) pressure, which has the effect of diminishing the weight of the dam, making it less stable.

Seepage through abutments or foundations can dissolve the constituents of certain rocks such as limestone, dolomite, or gypsum so that any cracks or joints in the rock become progressively larger and in turn allow more seepage. Abutment or foundation seepage may also result in “piping” internal erosion, in which the flow of water is fast enough to erode away small particles of soil. This erosion progresses from the water exit point backward to the entrance point. When that point is reached, water may then flow without restriction, resulting in even greater erosion and probable dam failure.

Obviously, large, unrestricted seepage is undesirable. To minimize this possibility, dams are constructed with internal impermeable barriers and internal drainage facilities such as drainpipes or filter systems, or other drainage systems such as toe, blanket, or chimney drains.

Flow through a dam foundation may be diminished by grouting known or suspected highly permeable material, constructing a cutoff wall or trench below a dam, or constructing an upstream impermeable blanket. Figure 2.1 illustrates a cutoff trench.

In summary, the overall water retention ability of a dam depends on its permeability, the abutments, the foundation, and the efforts made to reduce that permeability or restrict the

flow of water through these components. Should high permeability occur, seepage can lead to piping, which will likely result in failure.

2.4 Release of Water

Intentional release of water, as stated earlier, is confined to water releases through a service spillway or outlet works or over emergency spillways.

A. Service (Principal) or Mechanical

Spillway—The service (principal) or mechanical spillway maintains the normal water level in the reservoir. Its function is to pass expected flood flows past the dam safely and without erosion. It may consist of a pipe through the dam or a system of gates that discharge water over the top into a concrete spillway. Either method uses the overflow principle. When the

reservoir reaches a certain level, water flows into a standpipe or riser pipe or over a gate. Intake structures for spillways must have systems that prevent clogging by trash or debris.

B. Drawdown Facility

—All dams should have some type of drawdown facility which can:

- Quickly lower the water level if failure of the dam is imminent.
- Serve the operational purposes of the reservoir.
- Lower the water level for dam repairs.
- Purposely fluctuate the pool level to kill weeds and mosquitoes.

The valve regulating the drawdown facility should be on the upstream end of the conduit to minimize the risk to the dam posed by a possible internal rupture of the pipe.

C. Emergency (Auxiliary) Spillway

—As the name implies, an emergency

spillway functions during emergency conditions to prevent overtopping of a dam. A typical emergency spillway is an excavated channel in earth or rock near one abutment of a dam. An emergency spillway should always discharge away from the toe of a dam to avoid its erosion. Furthermore, the spillway should be constructed in such a manner that the spillway itself will not seriously erode when it is in use. Obviously, erosional failure of the spillway could be as catastrophic as failure of the dam itself. An emergency spillway should be sized to convey the so-called “design flood”—the rare, large-magnitude flood used to establish design criteria. The spillways of many existing dams are now considered undersized because standards for the design flood have increased over the years.

Chapter 3: Hazards, Risks, Failures

3.0 General

Dam failures are severe threats to life and property and are now being recorded and documented much more thoroughly than in the past. Recorded losses have been high. Statistics on losses of life and property fully justify the need for dam owners to better understand the risks to the public posed by dams, the kinds of hazards that promote those risks and owner liabilities associated with them, and, generally, the reasons that dams fail. Improving a dam owner's understanding of realistic risks and possible reasons for failure is an essential first step in any overall effort to improve dam safety and preserve the benefits of dam ownership.

3.1 Hazards as Sources of Risk

The dam structure itself can be a source of risk due to possible construction flaws and weaknesses that develop because of aging. The site immediately surrounding the structure may also increase the structural risk if the dam is not positioned or anchored properly or if excessive reservoir seepage erodes the foundation or abutments.

The physical hazards that can cause dam failure are translated into high risks when people or property are threatened, and where the high risks to which Americans are exposed are exacerbated by a number of important factors. For instance, in most states, people are allowed to settle below dams in potential inundation zones, thereby compounding risk.

Natural hazards such as floods, earthquakes, and landslides are also important contributors to risk. These natural phenomena existed long before humanity established patterns of settlement and are considered hazards because development has placed people and property in their way. Failure to adjust to these events has been costly both to dam owners and to the public in general.

Human behavior is another element of dam failure risk; simple mistakes, operational mismanagement, negligence, unnecessary oversights, or destructive intent can interact with other hazards to compound the possibility of failure. Thus, a broad range of natural and human hazards, taken separately or in combination, increase the probability of dam failure and injury to people and property.

The following discussion of some of the most significant hazards that lead to public risk illustrates the interrelationships among events that can lead to dam failure.

3.1.1 Natural Hazards That Threaten Dams

The most important natural hazards threatening dams include:

- flooding from high precipitation
- flooding from dam failure
- earthquakes
- landslides

Flooding from high precipitation. Of the natural events that can impact dams, floods are the most significant. A floodplain map of the U.S. (Figure 3.1) gives

some idea of the major flood prone areas. Flash floods can happen anywhere—even on small drainage areas but especially in the west. Floods are the most frequent and costly natural events that lead to disaster in the U.S. Therefore, flood potentials must be included in risk analyses for dam failure. Hurricanes and tropical storms can stall over an area, creating a significant precipitation event that can result in flooding. See Table 3.1 for extreme precipitation events in Texas.

Texas has design flood criteria derived from a percentage of the probable maximum flood (PMF) based on the dam's hazard potential and size classification. A PMF is the flood that may be expected from the most severe combination of critical meteorologic and hydrologic conditions that are reasonably possible in the region. This assumed event becomes the basis for the design of structural and hydraulic elements of the dam.

Flooding from dam failure. When a dam fails as a result of a flood, more people and property are generally placed in jeopardy than during natural floods. The Rapid City, South Dakota, flood of 1970, which killed 242 people, caused a dam failure which added significantly to the loss of life. When a natural flood occurs near a dam, the probability of failure and loss of life almost always increases.

The sudden surge of water generated by a dam failure usually exceeds the maximum flood expected naturally; dam-failure inundation zones and 100-year

Table 3.1
Extreme Precipitation in Texas

Location	Dates	Inches	Duration (hr)	Comments
Thrall	Sept. 9-10, 1921	38.2	24	36.4" in 18 hr
D'Hannis	May 31, 1935	22	3	
New Braunfels	May 11, 1972	16	4	
Taylor Ranch (San Saba Co.)	July 3, 1976	17.83	24	
Albany	August 4, 1978	29.05	24	23" in 8 hr
Medina	August 4, 1978	48	52	
Alvin	July 26, 1979	25.75	24	NWS reported 42" in 19 hr
Odem	Oct. 19, 1984	26	4	
Comanche	May 31, 1988	18	5	
Pearland	Oct. 17, 1994	28.2	48	
Lake Conroe	Oct. 16-19, 1994	27.76	96	

Sources: Bomar (1983); National Weather Service, San Antonio; NWS, Houston-Galveston; U.S. Geological Survey (2003).

floodplains are seldom congruent. The upper portion of an inundation zone almost always exceeds the 100-year floodplain considerably; therefore, residences and businesses that would escape natural flooding can be at extreme risk from dam failure flooding. Hence, it is important to inform residents and business personnel of the full risk to which they are exposed so that they can respond accordingly.

When one dam fails, the sudden surge of water may well be powerful enough to destroy another dam downstream, compounding the disaster. The potential for such a snowball effect is great, but the problem may seem remote to a dam owner who has not studied the potential impacts of upstream dams on his or her own structure. Upstream dams may seem too

Figure 3.1
Estimated Proportion of Land in Floodplain

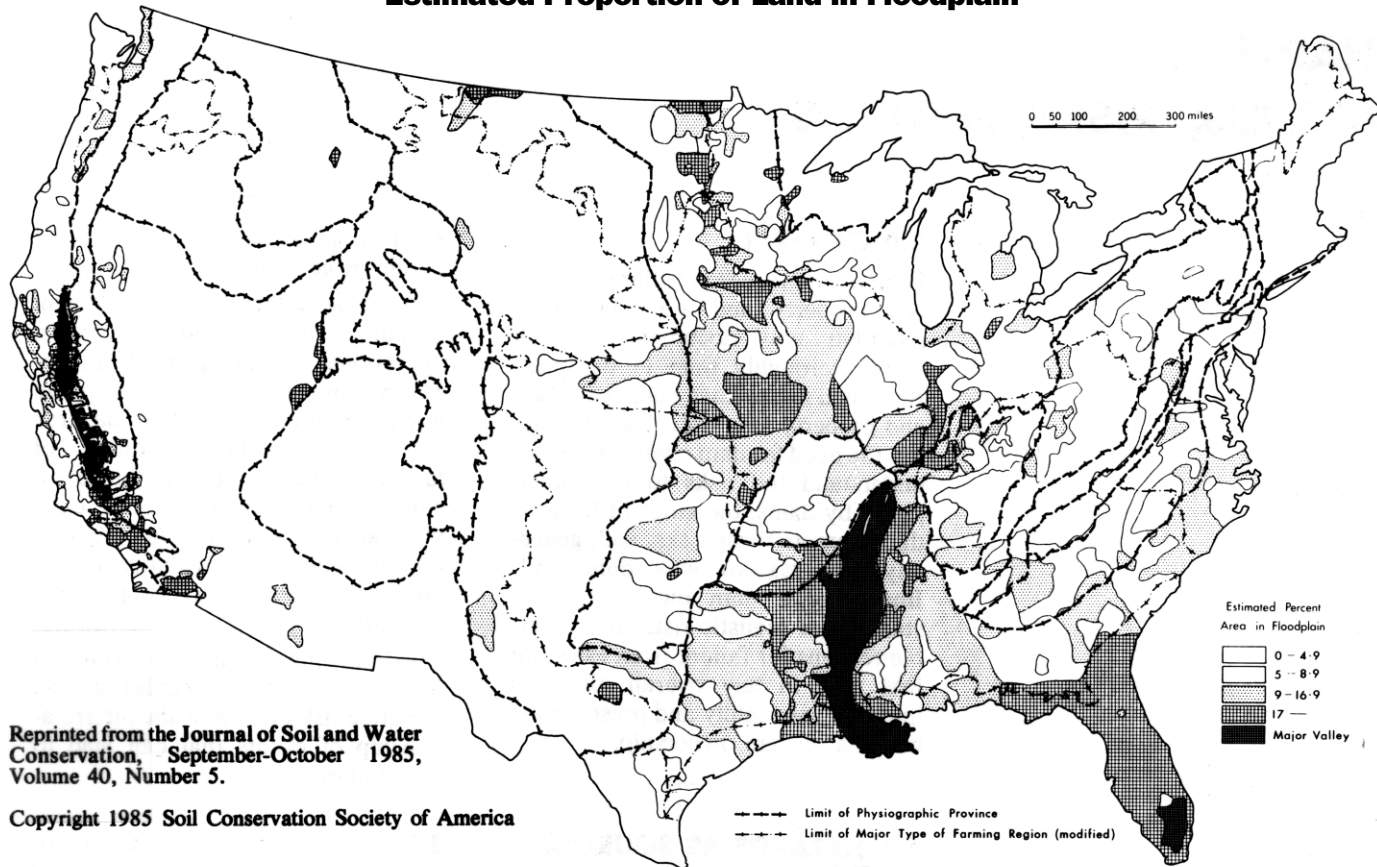

Reprinted from the *Journal of Soil and Water Conservation*, September-October 1985, Volume 40, Number 5.

Copyright 1985 Soil Conservation Society of America

Source: Thompson and White (1985: 417).

far away to be a real threat, but inundation zones and surge crests can extend many miles downstream, especially if the reservoir behind the collapsed dam held a large quantity of water.

Earthquakes. Earthquakes are also significant threats to dam safety. Both earthen and concrete dams can be damaged by ground motions caused by seismic activity. Cracks or seepage can develop, leading to immediate or delayed failure. Dams such as those in California—located near relatively young, active faults—are of particular concern, but dams (especially older concrete and earthen structures) located where relatively low-scale seismic events may occur are also at risk. Areas of the U.S. where significant seismic risks exist are indicated in Figure 3.2. However, recent detailed seismic analyses have indicated a much broader area of seismic activity sufficient to damage dams than previously considered; the seismic risk is essentially nationwide. Dam owners should be aware of the

history of seismic activity in their locality and should develop their emergency procedures accordingly.

Landslides. Rock slides and landslides may affect dams directly by blocking a spillway or by eroding and weakening abutments. Indirectly, a large landslide into a reservoir behind a dam can cause an overflow wave that will exceed the capacity of the spillway and lead to failure. A landslide (or mudslide) can form a natural dam across a stream which can then be overtopped and fail. In turn, failure of such a natural dam could then cause the overtopping of a downstream dam or by itself cause damage equivalent to the failure of a human-built dam. In addition, large increases in sediment caused by such events can materially reduce storage capacity in reservoirs and thus increase a downstream dam’s vulnerability to flooding. Sedimentation can also damage low-level gates and water outlets; damage to gates and outlets can lead to failure.

3.1.2 Hazards From Human Activity

Human activity must also be considered when analyzing the risks posed by dams. In Texas, the hazard classification of dams is based on the potential for loss of life and economic loss in the area downstream of the dam, not on its structural safety. Thus, dams that may be of very sound construction are labeled “high hazard” if failure could result in catastrophic loss of life—in other words, if people have settled in the potential inundation zone. The “high hazard” designation does not imply structural weakness or an unsafe dam. See 30 Texas Administrative Code Chapter 299 for the Texas criteria for classifying dams in the three hazard potential categories.

Risk may well increase through time because few governmental entities have found the means to limit settlement below dams. The hazard level of more dams is rising to “high” or “significant” as develop-

Figure 3.2
Seismic Map of the United States

ZONE 0 No damage.

ZONE 1 Minor damage, distant earthquakes may cause damage to structures with fundamental periods greater than 10 seconds, corresponds to intensities V and VI of the M.M.* Scale.

ZONE 2 Moderate damage, corresponds to intensity VII of the M.M.* Scale.

ZONE 3 Major damage, corresponds to intensity VIII and higher of the MM* Scale.

ZONE 4 Those areas within Zone 3 determined by the proximity to certain fault systems

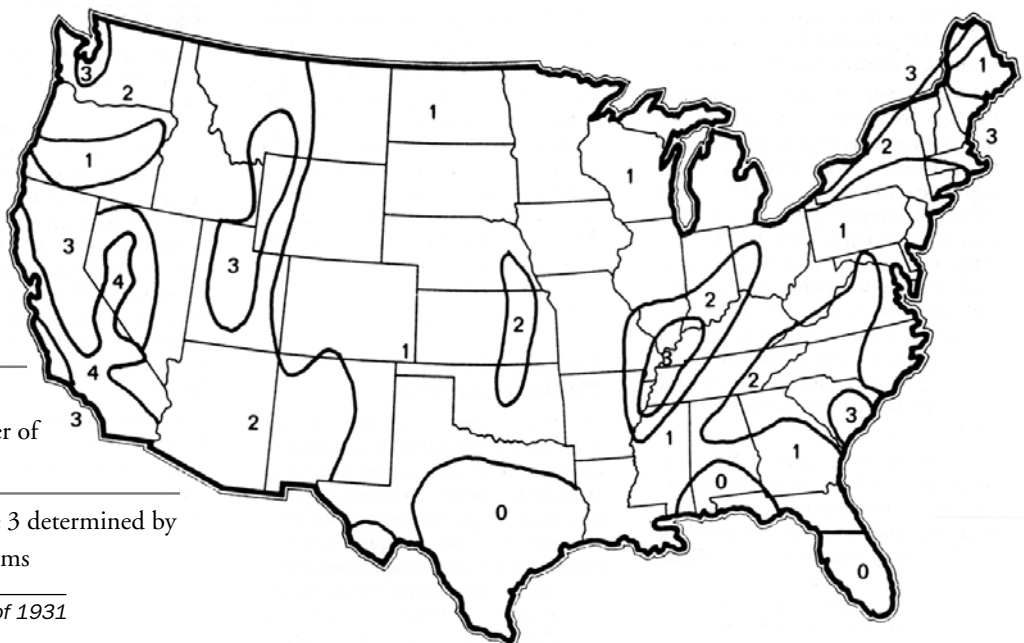

*Modified Mercatal Intensity Scale of 1931

Source: U.S. Army Corps of Engineers (1985).

ment occurs in potential inundation zones below dams previously rated “low hazard.”

Many other complex aspects of settlement and development must be considered in assessing dam risks. Because of short-term revenue needs or other pressures, governments often permit development in hazardous areas despite long-term danger and the risk of high future disaster costs. Diversion of development away from potential inundation zones is a sure means of reducing risk, but is not always a policy suitable to the immediate needs of local government. Perhaps the ultimate irony for a dam owner is to have developed and implemented a safety program and then to have development permitted in the potential inundation zone so that the hazard rating and owner’s liability increase.

Two extremes of human purpose, the will to destroy through war or terrorism and the urge to develop and to build, can both result in public risks. Dams have proven to be attractive wartime targets, and they may be tempting to terrorists. On the other hand, a terrorist’s advantage from holding the public at risk may well be illusory; the deliberate destruction of a dam is not at all easy to bring about. Yet the possibility exists that such an act could take place, and it should not be discounted by the dam owner.

All sorts of other human behavior should be included in risk analyses; vandalism, for example, cannot be excluded and is in fact a problem faced by many dam owners. Vegetated surfaces of a dam embankment, mechanical equipment, manhole covers and rock riprap are particularly susceptible to damage by people. Every precaution should be taken to limit access to a dam by unauthorized persons and vehicles. Dirt bikes (motorcycles) and off-road vehicles, in particular, can severely degrade the vegetation on embankments. Worn areas lead to erosion and more serious problems.

Mechanical equipment and associated control mechanisms should be protected from tampering, whether purposeful or inadvertent. Buildings housing mechanical equipment should be sturdy, have protected windows, and heavy-duty doors, and be secured with padlocks. Detachable controls, such as handles and wheels, should be removed when not in use and stored inside the padlocked building. Other controls should be secured with locks and heavy chains where possible. Manhole covers are often removed and sometimes thrown into reservoirs or spillways by vandals.

Rock used as riprap around dams is sometimes thrown into the reservoirs, spillways, stilling basins, pipe-spillway risers, and elsewhere. Riprap is often displaced by fishermen to form benches. The best way to prevent this abuse is to use rock too large and heavy to move easily, or to slush-grout the riprap. Otherwise, the rock must be regularly replenished and other damages repaired. Regular visual inspection can easily detect such human impacts.

Owners should be aware of their responsibility for the safety of people using their facility even though their entry may not be authorized. “No Trespassing” signs should be posted, and fences and warning signs erected around dangerous areas. As discussed in Chapter 10, liability insurance can be purchased for protection in the event of accidents.

3.2 Site-Specific Structural Risk

Developing site-specific risk analyses involves consideration of a number of hazards. Such analyses are helpful in stimulating better awareness, planning, and design. In some cases dam-structure analyses are quantitative and precise conclusions about engineering and design can be made. Probabilistic analyses can

also be important and useful. Still, exact quantitative and probabilistic tools are not yet applicable in many situations and do not fully supplement or replace qualitative analyses—informed perception and judgment of the risks. Judgment and engineering experience should play an important role in reaching useful conclusions in any site-specific analysis of structural risk.

As mentioned in Chapter 2, structural risks tend to result from design and construction problems related to the dam materials, construction practice, and hydrology. The complexity of the hazard is such that structural design and causes of dam failure are significant areas of research in engineering. Indeed, better design criteria have been developed and safer dams are being built, but there is no basis for complacency. Dams continue to age, people continue to move into inundation zones, and enough hazards exist that the net risk to the public will remain high.

3.3 Sources of Dam Failure

There are many complex reasons—both structural and non-structural—for dam failure. Many sources of failure can be traced to decisions made during the design and construction process and to inadequate maintenance or operational mismanagement. Failures have also resulted from the natural hazards already mentioned—large-scale flooding and earthquake movement. However, from your perspective as owner, the structure of a dam is the starting point for thorough understanding of the potentials for failure.

3.3.1 Three Categories of Structural Failure

Three categories of structural failure alluded to in Chapter 2 are:

- overtopping by flood

- foundation defects
- piping and seepage

Overtopping may develop from many sources, but often evolves from inadequate spillway design. Alternatively, even an adequate spillway may become clogged with debris. In either situation, water pours over other parts of the dam, such as abutments or the toe, and erosion and failure follow.

Concrete dams are more susceptible to foundation failure than overtopping, whereas earthen dams suffer from seepage and piping.

Overall, these three events have about the same incidence. A more specific analysis of the potential sources of failure has to take into account types of dams. Similarly, the characteristics of the type of dam being monitored will point to problems requiring more careful attention by the owner when developing a safety program.

3.3.2 Failures by Dam Type

Embankment or Earthen Dams. The major reason for failure of fill or embankment dams is piping or seepage, though other hydrologic failures are significant, including overtopping and erosion from water flows. All earthen dams exhibit some seepage; however, as discussed earlier, this seepage can and must be controlled in velocity and amount. Seepage occurs through the structure and, if uncontrolled, can erode material from the downstream slope or foundation backward toward the upstream slope. This “piping” phenomenon can lead to a complete failure of the structure. Piping action can be recognized by an increased seepage flow rate, the discharge of muddy or discolored water below the dam, sinkholes on or near the embankment, and a whirlpool in the reservoir.

Earthen dams are particularly susceptible to hydrologic failure since most

Box 3.1 Examples of Earthen-Dam Failures

SOUTHFORK, PENNSYLVANIA

The famous Johnstown disaster, caused by the failure of the South Fork Dam in 1889, in which 2,209 people were killed, is an example of the overtopping of an earthen dam. Heavy rainfall in the upper drainage basin of the dam filled the reservoir and caused overtopping. It was later calculated that, if a spillway had been built according to specifications and if the original outlet pipes had been available for full capacity discharge, there would have been no overtopping.

TETON DAM, IDAHO

The Teton Dam failure in 1976 was attributed to (1) internal erosion (piping) of the core of the dam deep in the right foundation key trench, with the eroded soil particles finding exits through channels in and along the interface of the dam with the highly pervious abutment rock and talus to points at the right groin of the dam; (2) destruction of the exit avenues and their removal by the outrush of reservoir water; (3) the existence of openings through inadequately sealed rock joints which may have developed through cracks in the core zone in the key trench; (4) the development of piping through the main body of the dam that quickly led to complete failure; and (5) the design of the dam did not adequately take into account the foundation conditions and the characteristics of the soil used for filling the key trench.

BALDWIN HILLS AND ST. FRANCIS DAMS, CALIFORNIA

The Baldwin Hills Dam failed in 1963 following displacement of its foundation. Foundation problems were ultimately traced to seismic activity along nearby faults. The failure of the large St. Francis Dam (part of the water supply system for Los Angeles) in 1928 was also attributed to a variety of problems related to foundation pressures, seepage around the foundation, and faulty operation.

Source: Jansen, 1980.

Box 3.2 Examples of Concrete-Dam Failures

AUSTIN, PENNSYLVANIA

An example of a foundation problem can be found in the failure of the Austin, Pennsylvania Dam in September, 1911. Evidently, the reservoir was filled before the concrete had set sufficiently. Eventual failure near the base occurred because of weakness in the foundation or in the bond between the foundation and the concrete.

WALNUT GROVE, ARIZONA

In 1890, the Walnut Grove dam on the Hassayompa River failed due to overtopping, killing about 150 people. The failure was blamed on inadequate capacity of the spillway and poor construction and workmanship. A spillway 6 x 26 feet had been blasted out of rock on one abutment, but, with a drainage area above the dam site of about 500 square miles, the spillway did not have nearly enough discharge capacity.

Source: Jansen, 1980.

sediments erode at relatively low waterflow velocities. Hydrologic failures result from the uncontrolled flow of water over the dam, around it, and adjacent to it, and the erosive action of water on the dam's foundation. Once erosion has begun during overtopping, it is almost impossible to stop. In a very special case, a well-vegetated earthen embankment may withstand limited overtopping if water flows over the top and down the face as an evenly distributed sheet and does not become concentrated in a single channel. Box 3.1 lists examples of earthen-dam failures caused by some of these conditions.

Concrete Dams. Failure of concrete dams is primarily associated with foundation problems. Overtopping is also a significant cause again primarily when spillways are built with inadequate capacity. Other causes include failure to let concrete set properly and earthquakes. The examples summarized in Box 3.2 illustrate typical foundation problems leading to dam failure.

3.3.3 Age and Its Relation to Failure

Foundation failures occur relatively early in the life of a dam, whereas other causes generally take much longer to materialize. Thus, it is not surprising that a very large percentage of all dam failures occur during initial filling, since that is when design or construction flaws, or latent site defects, appear.

As dams age, maintenance becomes more critical. Lack of maintenance will result in deterioration and eventually, failure.

Texas dams are aging as shown in Table 3.2, and problems as described above are slowly becoming apparent.

Table 3.2
Ages of Dams in Texas

Dates	Percentage of Dams
Prior to 1950	15.3
1950–59	15.3
1960–70	42.2
1971–80	18.7
1981–present	8.5

3.3.4 Condition Rating of Dam Conduits

As part of research work supported by the National Dam Safety Program, the National Performance of Dams Program

has developed an approach to predicting the condition of metal conduits in embankment dams. Utilizing the results of dam safety inspections from New Jersey, Washington, Virginia, Ohio, Kansas, and Oklahoma, a rating system was used to characterize the condition of metal conduits. Using these data, along with the age of the dam, a statistical model was developed to predict the condition of metal conduits as a function of age. The results of this assessment, combined with the recommendations of the dam inspectors, allow us to predict, as a function of age, the likelihood that a conduit will require repair or replacement (Figure 3.3).

Knowledge of the hazards, risks, and failures associated with dams is critical for owners. Consider each aspect of a safety program in relation to the most probable sources of failure for your dam in particular.

Figure 3.3
Prediction of the Likelihood of Metal Conduits Requiring Repair or Replacement as a Function of Age

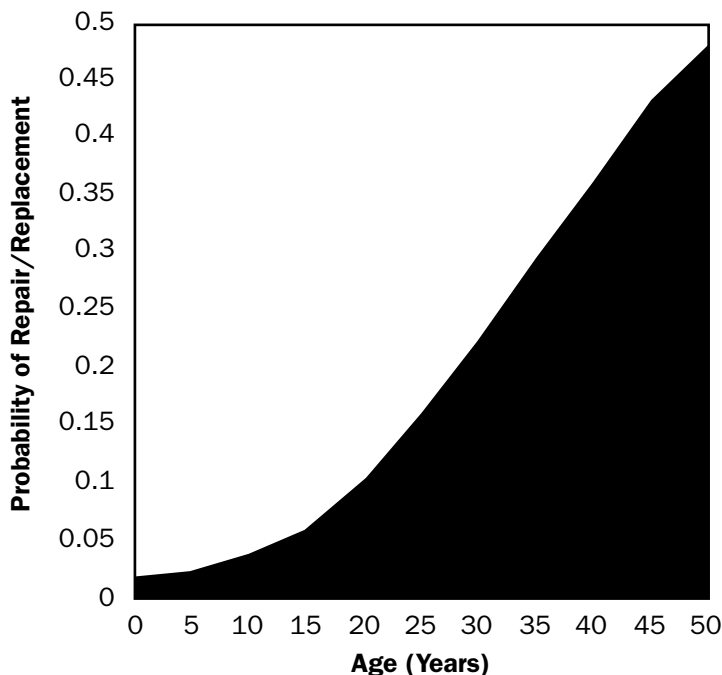

Source: National Performance of Dams Program, Stanford University (e-mail Communication, March 26, 2004).

Chapter 4: Developing a Safety Program

4.0 Objectives

The pressing issue of dam failure points up the need for a safety program. You, the owner, should base your program on an evaluation of your dam's structural and operational safety to identify problems and recommend either remedial repairs, operational restrictions and modifications, or further analyses and studies to determine solutions. Components of a safety program address the spectrum of possible actions to be taken over the short and long term:

- assessing the condition of the dam and its components
- conducting preliminary and detailed inspections
- identifying repairs and continuing maintenance needs
- establishing periodic and continuous monitoring capabilities over the long-term
- establishing an emergency action plan to help minimize adverse impacts should the dam fail
- establishing operations procedures which recognize dam failure hazards and risks
- documenting the safety program so that the information established is available at times of need and can be readily updated

Develop your safety program in phases, beginning with collection and review of existing information, proceeding to detailed inspections and analyses, and culminating with formal documentation.

You can accomplish much of the preliminary work personally, with the assistance of state and local agencies. However, depending upon the number and seriousness of problems identified by the initial assessment, you may require the professional assistance of qualified engineers and contractors.

4.1 Guidelines for Assessing Existing Conditions

The guidelines for assessing existing conditions involve a sequence of steps that will enable you, the owner, to secure the information you will need to determine whether subsequent detailed investigations, repairs, and maintenance are required. The steps include:

- reviewing existing data
- visiting the site
- inspecting the dam
- assessing significance of observed conditions
- deciding what to do next

Reviewing Existing Data. First (and crucially), collect and review available information on the dam—its design, construction, and operation. A first requirement is a good map of the site. Maps of the watershed and the downstream channel reaches are also valuable. Review the design of the dam and its appurtenant structures to assess its actual performance compared to that intended.

Also review engineering records originating during construction to verify that structures were constructed as designed. Collect records of subsequent construction modifications, as well as operation records that document the performance of the dam and reservoir. Review any previous emergency action plan to determine if it is up-to-date and workable. Incorporate all these records into a notebook or file; they are most important in establishing a safety program and serve as the basis for its supporting documentation. (For help with the development of such documentation, refer to Chapters 5 through 10.) Perhaps no records exist. In that case, a detailed examination of the structure is appropriate.

Visiting the Dam Site. Next, visit the site. Undoubtedly you know it well and have visited it many times, but in this visit there are particular things for you to look for. Take a fresh look at the dam structure and its surroundings from in view of their potential hazard.

Inspecting the Dam. Also, take a detailed and systematic look at all components of the dam and reservoir system. The description of the site's components in Chapter 2 should aid this inspection. (The descriptions are general, so bear in mind that dams and their components come in various shapes and sizes and differ greatly in detail). Features to inspect include:

- access roads and highways
- upstream slope
- crest
- downstream slope

- left and right abutments
- spillways
- outlets
- drains
- reservoir area (exposed and submerged)
- area immediately downstream of the dam
- downstream areas for change in hazard classification

Look for obvious deterioration, cracks and slumps, and boiling seepage and not-so-obvious internal corrosion and weathering, settlement, and foundation-rock deterioration and dissolution. A dam can look stable and still be susceptible to failure from gradual deterioration of its internal structure. Regular and very detailed inspections (Chapter 5) and follow-up monitoring (Chapter 6) and maintenance (Chapter 7) are needed to ensure maximum safety.

Assessing Significance of Observed Conditions. Chapter 5 presents detailed information on conducting inspections and assessing the significance of conditions

you observe. Typically, eroded areas, seepage, slides, and outflow draw the most attention.

Deciding What to Do Next. Your dam safety program is now off to a good start, with. Available information on design and construction of the dam and later structural modifications provides perspective on its existing condition relative to that intended. If no documentation exists, then development of equivalent detail should be a first priority. Assistance with inspection and documentation assistance is available from several sources, including the TCEQ, the state agency responsible for dam safety. Professional engineering consultants can also perform detailed inspections, testing, and analyses, and create documentation (Chapter 10).

4.2 Procedural Guidelines—A Source Book

This chapter provides an overview of how to establish a safety program.

Subsequent chapters detail technical and procedural steps of the program components. They include:

- detailed inspection guidelines (Chapter 5)
- monitoring and instrumentation guidelines (Chapter 6)
- maintenance guidelines (Chapter 7)
- emergency action guidelines (Chapter 8)
- operations guidelines (Chapter 9)

These program components can be visualized as a sequence of initial and continuing activities to insure dam safety (Figure 4.1).

Again, the program of inspection for both the initial and continuing safety evaluations establishes the condition of the dam and provides the base of information necessary for specific actions involving repair, operation, maintenance, and monitoring. The flowchart illustrates the cyclical nature of the program and the need for continuing vigilance. Emergency action can, it is hoped, be avoided, but a well-thought-out plan of action (Chapter 8) in case of imminent or actual failure can greatly reduce damage and loss of life.

Figure 4.1
Procedural Guidelines for a Dam-Safety Program

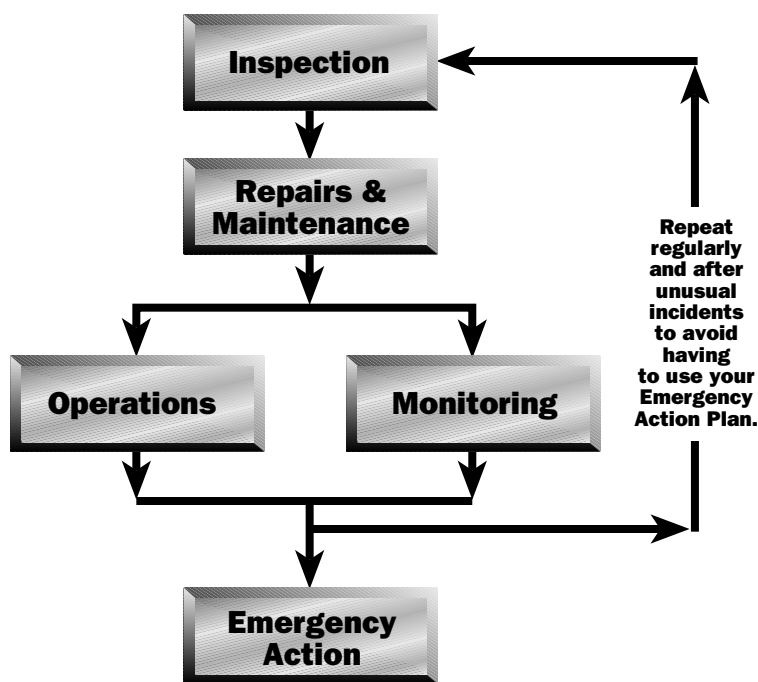

4.3 Documenting the Safety Program

It is important to document a safety program in order to make the best use of reliable information about the dam. The procedural guidelines that follow can serve as an outline or table of contents for a safety program report. The operations plan (Chapter 9) presents a detailed outline of the information that should be included in the documentation. The chapters that follow suggest forms for inspections, monitoring, etc., which can be used to record information. It is helpful to maintain all the material in a single notebook or file that is easily assessable so that it can be updated and available when needed. Store duplicate copies at a different location.

Chapter 5: Inspection Guidelines

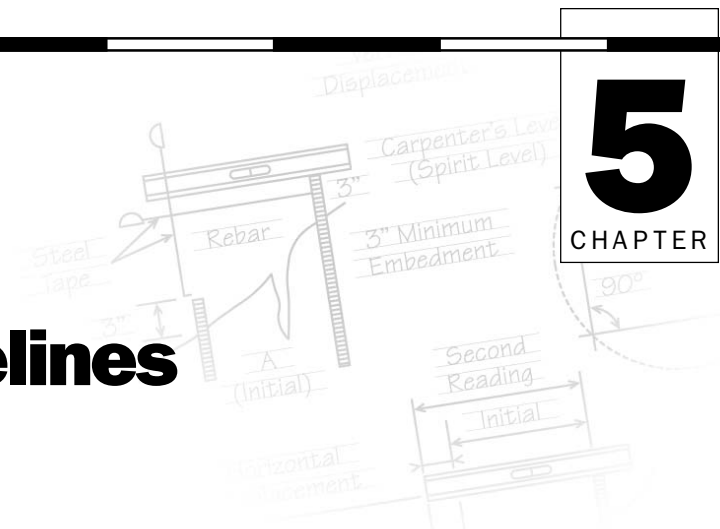

5.0 Introduction

An effective inspection program is essential for identifying problems and providing safe maintenance of a dam. An inspection program should involve three types of inspections: (1) periodic technical inspections; (2) periodic maintenance inspections; and (3) informal observations by project personnel as they operate the dam. Technical inspections must be performed by specialists familiar with the design and construction of dams and should include assessments of structure safety. Maintenance inspections are performed more frequently than technical inspections in order to detect, at an early stage, any developments that may be detrimental to the dam. They involve assessing operational capability as well as structural stability. The third type of inspection is actually a continuing effort by the dam owner's on-site project personnel (dam tenders, powerhouse operators, maintenance workers) performed in the course of their normal duties. The continued effectiveness of these inspections requires education of new personnel.

Regular visual inspections are among the most economical means you, the owner, can use to ensure the safety and long life of a dam and its immediate environment. Visual inspection is a straightforward procedure that can be used by any properly trained person to make a reasonably accurate assessment of a dam's condition. The inspection involves careful

examination of the surface and all parts of the structure, including its adjacent environment. The equipment required is not expensive, and the inspection usually can be completed in less than one day.

A dam owner, by applying the maximum prudent effort, can identify any changes in previously noted conditions that may indicate a safety problem. Quick corrective action to conditions requiring attention will promote the safety and extend the useful life of the dam while possibly preventing costly future repairs.

5.1 Organizing for Inspection

All inspections should be organized and systematic, and inspectors should use equipment appropriate for the task, record observations accurately, and survey the structure and site comprehensively. It is essential that documentation be developed and maintained in order to ensure adequate follow-up and repair. Chapter 9 further discusses what form this documentation should take.

Equipment useful for inspections is listed in Table 5.1.

Recording Inspection Observations. An accurate and detailed description of conditions during each inspection will enable meaningful comparison of conditions observed at different times. The inspector should record all measurements and observed details required for an accurate picture of a dam's current condition and possible problems. Using the

forms discussed in Chapter 9 and given in the appendixes will help record the details. This information has three elements:

- (1) *Location*—Accurately describe the location of any questionable area or condition so that it can be evaluated for changes over time or reexamined by experts. Photographs can help. Record the location along the dam, as well as above the toe or below the crest. Similarly, document the location of problems in the outlet or spillway.
- (2) *Extent or area*—The length, width, and depth or height of any suspected problem area should be determined.
- (3) *Descriptive detail*—Give a brief yet detailed description of any anomalous condition. Some items to include:
 - quantity of drain outflows
 - quantity of seepage from point and area sources
 - color or quantity of sediment in water
 - depth of deterioration in concrete
 - length, displacement, and depth of cracks
 - extent of moist, wet, or saturated areas
 - adequacy of protective cover
 - adequacy of surface drainage
 - steepness or configuration of slopes
 - apparent deterioration rate
 - changes in conditions

Coverage. An inspection is conducted by walking along and over a dam as many times as is required to observe the entire

**Table 5.1
Inspection Equipment and Its Use**

<p>Notebook and pencil—should be available so that observations can be written down at the time they are made, reducing mistakes and avoiding the need to return to the site to refresh the inspector’s memory.</p> <p>Inspection checklist—serves as a reminder of all important conditions to be examined.</p> <p>Tape recorder—can be effective in making a record of field observations.</p> <p>Digital camera—can be used to photograph field conditions. Photographs taken from the same vantage points can also be valuable in comparing past and present conditions. Photographs can also be e-mailed to consultants or the Texas Dam Safety Program when necessary.</p> <p>Hand level—may be needed to accurately locate areas of interest and to determine embankment heights and slope.</p> <p>Probe—used to gather information on conditions below the surface, such as the depth and softness of a saturated area.</p> <p>Hard hat—should be used when inspecting large outlets or working in construction areas.</p> <p>Pocket tape—allows for accurate measurements so that meaningful comparisons can be made of movements.</p> <p>Flashlight—may be needed to inspect the interior of an outlet in a small dam.</p> <p>Shovel—useful in clearing drain outfalls, removing debris, and locating monitoring points.</p> <p>Rock hammer—can be used to check questionable-looking riprap or concrete for soundness. Care must be taken not to break through thin spots or cause unnecessary damage.</p>	<p>Tapping device—is used to determine the condition of support material behind concrete or asphalt faced dams by firmly tapping the surface of the facing material. Concrete fully supported by fill material produces a “click” or “bink” sound, while facing material over a void or hole produces a “clonk” or “bonk” sound. The device can be made from a 1 -inch hardwood dowel with a metal tip firmly fixed to the tapping end, or it can be a length of reinforcing steel.</p> <p>Binoculars—useful for inspecting limited-access areas, especially on concrete dams.</p> <p>Volume container and timer—used to make accurate measurements of the rate of leakage. Various container sizes may be required, depending on the flow rates.</p> <p>Stakes and flagging tape—used to mark areas requiring future attention and to stake the limits of existing conditions, such as cracks and wet areas, for future comparison.</p> <p>GPS receiver—used to collect positional data on locations of interest.</p> <p>Slope tool—used to measure degree of slope from horizontal.</p> <p>Watertight boots—recommended for inspecting areas of the site where water is standing.</p> <p>Snake leggings or chaps—recommended for situations where heavy brush or snakes may be encountered.</p> <p>Bug repellent—recommended during warm weather. Insects that bite can reduce the efficiency and effectiveness of the inspector.</p> <p>First-aid kit—particularly recommended for inspections in areas where poisonous snakes might be present.</p>
--	---

structure. From any given location, a person can usually gain a detailed view for 10 to 30 feet in each direction, depending upon the smoothness of the surface or the type of material (grass, concrete, riprap, brush) on the surface. On the downstream slope, a zigzag inspection path will ensure that any cracking is detected.

Sequence. Here is sequence of inspection that ensures systematic coverage of an entire site:

- upstream slope
- crest
- downstream slope

- seepage areas
- inlet
- outlet
- spillway

Following a consistent sequence lessens the chance of an important condition being overlooked. Reporting inspection results in the same sequence is recommended to ensure consistent records. Inspection forms are included in Appendix A. The forms should be supplemented with additional details specific to a given dam.

Record keeping. The inspector should fill out a dated report for each inspection, which should be filed along with any photographs taken (which should also be dated). In addition to inspection observations, monitoring measurements and weather conditions (especially recent rains, extended dry spells and snow cover) should also be systematically included in the inspection record. A sketch of the dam with problem areas noted is helpful.

Immediately following an inspection, observations should be compared with previous records to see if there are any

trends that may indicate developing problems. If a questionable change or trend is noted, and failure is not imminent, you, the owner, should consult a professional engineer experienced in dam safety. Reacting quickly to questionable conditions will ensure the safety and long life of a dam and possibly prevent costly repairs or expensive litigation.

Crucial inspection times. There are at least five special times when an inspection is recommended regardless of the regular schedule:

- (1) Prior to a predicted major rainstorm or heavy snow melt: check spillway, outlet channel, and riprap.
- (2) During or after a severe rainstorm: check spillway, outlet channel, and riprap.
- (3) During or after a severe windstorm: check riprap performance during the storm (if possible) and again after the storm has subsided.
- (4) Following an earthquake in the area: make a complete inspection immediately after the event and weekly inspections for the next several months to detect any delayed effects.
- (5) During and immediately after the first reservoir filling: schedule a regular program of frequent complete inspections during the period a reservoir is first being filled to ensure that design and site conditions are as predicted. In most states, including Texas, an inspection and filling schedule are prescribed by the design engineer and approved by the state engineer.

5.2 Embankment Dams and Structures

Embankment dams constitute the majority of structures in place in the U.S. The major features include:

- upstream slope

- downstream slope
- crest
- seepage areas

A spillway is also a necessary feature (Section 5.4). Many of the principles and guidelines presented in that section are also applicable to concrete structures.

5.2.1 Upstream Slope

Typically, major problems encountered on an upstream slope are:

- cracks
- slides
- cave-ins or sinkholes
- severe erosion

The first three conditions may indicate serious problems within the embankment. Severe erosion obviously can weaken the structure. An upstream slope should receive a close inspection because riprap, vegetative cover, and high water levels can hide problems. (When walking on riprap, take caution to avoid personal injury.) When a reservoir is emptied, the exposed slope should be thoroughly inspected for settlement areas, rodent (beaver) activity, sinkholes, or slides. Also, the reservoir basin (bottom of the reservoir) should be inspected for cave-ins or sinkholes.

Again, most importantly, a crisscross path should be used when inspecting the slope so that cracks and slides can be easily identified. In many instances, sighting along the waterline alignment will indicate a change in the uniformity of the slope; an inspector should stand at one end of the dam and sight along the waterline, checking for straightness and uniformity. If a crack is seen, the crest and downstream slope in its immediate area should be carefully inspected.

Cracks indicate possible foundation movement, embankment failure, or a surface slide. Locating them can be difficult. Cracks less than an inch in width can still be several feet deep. Cracks more

than one foot deep usually are not produced by drying and usually are cause for concern. A line of recently dislodged riprap on an upstream slope could indicate a crack below the riprap.

Slides can be almost as difficult to detect as cracks. When a dam is constructed, the slopes may not be uniformly graded. Familiarity with the slope configuration at the end of construction can help identify subsequent slope movements. Moreover, the appearance of slides may be subtle; for example, they may produce only about two feet of settlement or bulging in a distance of 100 feet or more, yet that would still be a significant amount of settlement. Dated photographs are particularly helpful in detecting such changes.

Sinkholes or cave-ins result from internal erosion of the dam—a very serious condition for earthen embankments. The internal erosion, or piping, may be reflected by turbid seepage water on exit. Surface soil may be eroded by wave action, rain runoff, and animal burrowing. Such erosion, if allowed to continue, can lessen the thickness of the embankment and weaken the structure.

Animal burrows on the upstream slope can also indicate a serious problem on smaller dams. Beavers, nutria, and other burrowing animals can create pathways for seepage. See Chapter 7.

To ensure adequate inspection and prevent potential seepage paths, keep the upstream slope free from obscuring weeds, brush, or trees.

Figures 5.1 show potential problems with the upstream slope, causes, possible consequences, and recommended actions.

5.2.2 Downstream Slope

A downstream slope should be inspected carefully because it is the area where evidence of developing problems appears most frequently. To ensure

adequate inspection, keep this area free from obscuring weeds, brush, or trees.

When cracks, slides or seepage are noted in the downstream slope, notify the designated dam-safety authorities immediately.

On the downstream slope, some of the more threatening conditions that could be identified are:

- cracks
- slides
- seepage

Cracks can indicate settlement, drying and shrinkage, or the development of a slide. Whatever the cause, cracks should be monitored and changes in length and width noted. Drying cracks may appear and disappear seasonally and normally will not show vertical displacement as will settlement cracks or slide cracks.

Slides require immediate detailed evaluation. Early warning signs include a bulge in the embankment near the toe of a dam or vertical displacement in the upper portion of an embankment.

Seepage is discussed separately below (Section 5.2.4).

If a downstream slope is covered with heavy brush or vegetation, a more concentrated search must be made and may require cleaning off the vegetation.

In addition, the downstream slope should be inspected for animal burrows and excessive vegetative cover and for erosion, especially at the contacts with the abutments,.

Figures 5.2 show potential problems with the downstream slope, causes, possible consequences, and recommended action.

5.2.3 Crest

A dam's crest usually provides the primary access for inspection and maintenance. Because surface water will pond on a crest unless that surface is well maintained, this part of a dam usually requires periodic regrading. However, problems found on the crest should not be simply graded over

or covered up. When a questionable condition is found, the Texas Dam Safety Program should be notified immediately.

On the crest, some of the more threatening conditions that may be identified are:

- longitudinal cracking
- transverse cracking
- misalignment
- sinkholes

Longitudinal cracking can indicate localized instability, differential settlement, movement between adjacent sections of the embankment, or any combination of the three. Longitudinal cracking is typically characterized by a single crack or a close, parallel system of cracks along the crest, more or less parallel to the axis of the dam. These cracks, which are usually continuous over their length and usually greater than one foot deep, can be differentiated from drying cracks, which are usually intermittent, erratic in pattern, shallow, very narrow, and numerous.

Longitudinal cracking may precede vertical displacement as a dam attempts to adjust to a position of greater stability. Frequently, longitudinal cracking occurs at the edge of the crest with either slope. Vertical displacements on the crest are usually accompanied by displacements on the upstream or downstream face of a dam.

Transverse cracking can indicate differential settlement or movement between adjacent segments of a dam. Transverse cracking usually manifests as a single crack or a close, parallel system of cracks that extend across the crest more or less perpendicular to the length of the dam. This type of cracking is usually greater than one foot in depth. If this condition is seen or suspected, notify the Texas Dam Safety Program office immediately.

Transverse cracking poses a definite threat to the safety and integrity of a dam. If a crack should progress to a point below the reservoir water-surface elevation,

seepage could progress along the crack and through the embankment, causing severe erosion and—if not corrected—leading to failure of the dam.

Misalignment can indicate relative movement between adjacent portions of a dam—generally perpendicular to its axis. Excessive settlement of dam material, the foundation, or both can also cause misalignment. Most problems are usually detectable during close inspection. Misalignment may, however, only be detectable by viewing a dam from either abutment. If on close inspection the crest appears to be straight for the length of the structure, alignment can be further checked by standing away from the dam on either abutment and sighting along the upstream and downstream edges of the crest. On curved dams, alignment can be checked by standing at either end of a short segment of the dam and sighting along the crest's upstream and downstream edges, noting any curvature or misalignment in that section. Leaning utility poles or poles used for highway barriers also can indicate movement.

Sinkholes can indicate internal collapse, piping, or the presence of animal dens. The formation or progression of a sinkhole is dangerous because it poses a threat to inspectors or vehicles traversing the crest. A sinkhole collapse can also lead to a flow path through a dam, which can create an uncontrolled breach.

In addition, the crest should be inspected for animal burrows, low areas, vegetative cover, erosion, slope of the crest, narrowing of the crest, and traffic ruts.

Figures 5.3 show potential problems with the crest, causes, possible consequences, and recommended action.

5.2.4 Seepage Areas

As discussed previously, although all dams have some seepage, seepage in any area on or near a dam can be dangerous,

and all seepage should be treated as a potential problem. Wet areas downstream from dams are not usually natural springs, but seepage areas. Seepage must be controlled in both velocity and quantity. High-velocity flows through a dam can cause progressive erosion and, ultimately, failure. Saturated areas of an embankment or abutment can move in massive slides and thus also lead to failure.

Seepage can emerge anywhere on the downstream face of a dam, beyond the toe, or on the downstream abutments at elevations below normal reservoir levels. A potentially dangerous condition exists when seepage appears on the downstream face above the toe of a dam. If seepage is found on the top half of the downstream slope, the Texas Dam Safety Program should be notified immediately. Seepage on the downstream slope can cause a slide or failure of the dam by internal erosion (piping). Evidence of seepage may vary from a soft, wet area to a flowing spring and may appear initially as only an area where vegetation is lush and dark green in color. Cattails, reeds, mosses, and other marsh vegetation often become established in seepage areas. Downstream abutment areas should always be inspected closely for signs of seepage, as should the area of contact between an embankment and a conduit spillway, drain, or other appurtenant structures and outlets. Slides in the embankment or an abutment may be the result of seepage causing soil saturation and high pore pressures.

Since seepage can be present but not readily visible, an intensive search should be made of all downstream areas where seepage water might emerge. Even in short grass cover, seepage may not be visible and must be walked on to be found. Ideally, an inspection for seepage should be made when a reservoir is full.

Figures 5.4 show potential problems with seepage, causes, possible consequences, and recommended action.

5.3 Concrete Dams and Structures

From a safety standpoint, the principal advantage of concrete over earthen dams is their relative freedom from failure by erosion during overtopping as well as from embankment slides and piping failures. Although concrete dams comprise a minority of all dams, they are commonly of greater height and storage capacity than earthen structures. Thus, they often represent a potentially greater hazard to life and property. It is important that concrete-dam owners be aware of the principal modes of failure of such dams and that they be able to discern between conditions which threaten the safety of the dam and those that merely indicate a need for maintenance.

Concrete dams fail for reasons that are significantly different from earth dams. These include:

- structural cracks
- foundation and abutment weakness
- deterioration due to alkali-aggregate reaction

Should any of these conditions be discovered during inspection, an owner should obtain engineering assistance immediately.

Structural cracks occur when portions of the dam are overstressed; they result from inadequate design, poor construction, foundation settlement, or faulty materials. Structural cracks are often irregular, may run at an angle to the major axes of the dam and may exhibit abrupt changes in direction. These cracks can also be noticeably displaced, radially, transversely, or vertically.

Concrete dams transfer a substantial load to the abutments and foundation. Although the concrete of a dam may endure, the natural abutments or foundation may crack, crumble, or move in a massive slide. If that occurs, support for

the dam is lost and it fails. Impending failure of the foundation or abutments may be difficult to detect because initial movements are often very small.

Severe deterioration can result from a chemical reaction between alkali present in cements and certain forms of silica present in some aggregates. This chemical reaction produces by-products of silica gels, which cause expansion and loss of strength within concrete. An alkali reaction is characterized by certain observable conditions such as cracking (usually a random pattern on a fairly large scale), and by excessive internal and overall expansion. Additional indications include the presence of a gelatinous exudation or whitish amorphous deposits on the surface and a chalky appearance in freshly fractured concrete.

The alkali-aggregate reaction takes place in the presence of water. Surfaces exposed to the elements or dampened by seepage will deteriorate most rapidly. Once suspected, the condition can be confirmed by a series of tests performed on core samples drilled from a dam. Although the deterioration is gradual, an alkali-aggregate reaction cannot be economically corrected by any means now known. Continued deterioration may require total replacement of a structure.

Inspection of a concrete dam is similar to that of an earthen dam. However, the following additional items should be considered:

- access and safety
- monitoring
- outlet system
- cracks at construction and expansion joints
- shrinkage cracks
- deterioration due to spalling
- minor leakage

Access and safety are important because the faces of concrete dams are often nearly vertical, and sites are com-

monly steep-walled rock canyons. Access to the downstream face, toe area, and abutments of such dams may be difficult and require special safety equipment, such as safety ropes or a boatswain's chair. Concrete dams pose a special problem for the dam owner because of the difficulty in gaining close access to the steep surfaces. Regular inspection with a pair of powerful binoculars can initially identify areas where change is occurring. When changes are noted, a detailed, close-up inspection should be conducted. Close inspection of the upstream face may also require a boatswain's chair or a boat.

Monitoring helps detect structural problems in concrete dams such as cracks in the dam, abutments, or foundation. Cracks may develop slowly at first, making it difficult to determine if they are widening or otherwise changing over time. If a structural crack is discovered, it should be monitored for changes in width, length, and offset, and a monitoring network of instruments should be installed and read regularly.

Outlet-system deterioration is a problem for all dams, but the frequency of such damage may be higher in concrete dams because of their greater average hydraulic pressure. Thus, outlet-system inspection should be emphasized for large concrete dams.

Cracks at construction joints exist because concrete dams are built in segments, while expansion joints—referred to as “designed” cracks—are built into dams to accommodate volumetric changes which occur in the structures after concrete placement. These joints are typically constructed so that no bond or reinforcing, except non-bonded water stops and dowels, extend across the joints.

Shrinkage cracks often occur when, during original construction, irregularities or pockets in the abutment contact are filled with concrete and not allowed to cure fully prior to placement of adjacent

portions of the dam. Subsequent shrinkage of the concrete may lead to irregular cracking at or near the abutment.

Shrinkage cracks are also caused by temperature variation. During winter months, the upper portion of a dam may become significantly colder than those portions in direct contact with reservoir water. This temperature differential can result in cracks which extend from the crest for some distance down each face of the dam. These cracks will probably occur at construction or expansion joints, if any.

Shrinkage cracks can be a sign that certain portions of the dam are not carrying the design load. In such cases, the total compression load must be carried by a smaller proportion of the structure. It may be necessary to restore load-carrying capability by grouting affected areas. This work requires the assistance of an engineer.

Spalling is the process by which concrete chips and breaks away as a result of freezing and thawing, corrosion of the reinforcement, or movement. Almost every concrete dam in colder climates experiences continued minor deterioration due to spalling. Because it usually affects only the surface of a structure, it is not ordinarily considered dangerous. However, if allowed to continue, spalling can result in structural damage, particularly if a dam is thin in cross-section. Repair is also necessary when reinforcing steel becomes exposed. The method of repairing spalled areas depends upon the depth of the deterioration. In severe situations, engineering assistance is required.

Minor leakage through concrete dams, although unsightly, is not usually dangerous unless accompanied by structural cracking. The effect may be to promote deterioration due to freezing and thawing. However, increases in seepage could indicate that, through chemical action, materials are being leached from the dam and carried away by the flowing water. Dam owners should note that decreases in

seepage can also occur as mineral deposits are formed in portions of the seepage channel. In either case, the condition is not inherently dangerous and detailed study is required to determine if repair is necessary for other than cosmetic reasons.

Figures 5.4 show potential problems with concrete dams and structures, causes, possible consequences, and recommended action.

5.4 Spillways

As detailed in Chapter 2, the main function of a spillway is a safe exit for excess water in a reservoir. If a spillway is too small, a dam could be overtopped and fail. Similarly, defects in a spillway can cause failure by rapid erosion. A spillway should always be kept free of obstructions, have the ability to resist erosion, and be protected from deterioration. Because dams represent a substantial investment and spillways make up a major part of dam costs, a conscientious annual maintenance program should be pursued not only to protect the public but also to minimize costs as well.

The primary problems encountered with spillways include:

- inadequate capacity
- obstructions
- erosion
- deterioration
- cracks
- open joints
- undermining of the spillway outlet
- deterioration of spillway gates

Inadequate capacity is determined by several factors, such as the drainage area served, the magnitude or intensity of storms in the watershed, the storage capacity of the reservoir, and the speed with which rainwater flows into and fills the reservoir. An inadequate spillway can cause the water in a reservoir to overtop the dam.

A spillway may be obstructed by excessive growth of grass and weeds, thick brush, trees, debris, fences across channels to prevent migration of fish, or landslide deposits. An obstructed spillway can have a substantially reduced discharge capacity which can lead to overtopping of the dam. Grass is usually not considered an obstruction; however, tall weeds, brush, and young trees should periodically be cleared from spillways. Similarly, any substantial amount of soil deposited in a spillway—whether from sloughing, landslide or sediment transport—should be immediately removed. Timely removal of large rocks is especially important, since they can obstruct flow and encourage erosion.

Erosion of a spillway may occur during a large storm when large amounts of water flow for many hours. Severe damage of a spillway or complete washout can result if the spillway cannot resist erosion. If a spillway is excavated out of a rock formation or lined with concrete, erosion is usually not a problem. However, if a spillway is excavated in sandy soil, deteriorated granite, clay, or silt deposits, protection from erosion is very important. Generally, resistance to erosion can be increased if a spillway channel has a mild slope, or if it is covered with a layer of grass or riprap with bedding material.

A spillway cannot be expected to perform properly if it has deteriorated. Examples include the collapse of side slopes, riprap, concrete lining, approach section, the chute channel, the stilling basin, the discharge channel, or protective grass cover. These problems can cause water to flow under and around the protective material and lead to severe erosion. Remedial action must be taken as soon as any sign of deterioration has been detected.

Drying cracks in an earthen spillway channel are usually not regarded as a functional problem. However, missing rocks in a riprap lining can be considered a

crack in the protective cover, and must be repaired at once.

Cracks in concrete lining of a spillway are commonly encountered. These cracks may be caused by uneven foundation settlement, shrinkage, slab displacement, or excessive earth or water pressure. Large cracks will allow water to wash out fine material below or behind the concrete slab, causing erosion, more cracks, and even severe displacement of the slab. The slab may even be dislodged and washed away by the flow. A severely cracked concrete spillway should be examined by and repaired under the supervision of an engineer.

Open or displaced joints can occur from excessive and uneven settlement of the foundation or the sliding of a concrete slab. In some cases, a construction joint is too wide or has been left unsealed. Sealants deteriorate and wash away. Water can flow through the joints, undermining the slabs, which in turn could result in collapse of the spillway slabs. Pressures resulting from water flowing over the open slabs could also result in lifting and displacement of slabs. Joints need to be sealed and kept sealed.

Erosion of foundation material may weaken support and cause further cracks; pressure induced by water flowing over displaced joints may wash away part of a wall or slab, or cause extensive undermining.

Undermining of a spillway causes erosion at a spillway outlet, whether it be a pipe or overflow spillway, and is one of the most common spillway problems. Severe undermining of the outlet can displace sections of pipe, cause slides in the downstream embankment of the dam, and eventually lead to complete failure of a dam. Water must be conveyed safely from the reservoir to a point downstream of the dam without endangering the spillway itself or the embankment. Often the spillway outlet is adequately protected for normal flow conditions, but not for extreme turbulent flows. It is easy to mis-

estimate the energy and force of flowing water and the resistance of outlet material (earth, rock, concrete, etc). The required level of protection is difficult to establish by visual inspection but can usually be determined by hydraulic calculations performed by a professional engineer.

Structures that completely control erosion at a spillway outlet are usually expensive, but often necessary. Less expensive protection can also be effective, but require extensive periodic maintenance as areas of erosion and deterioration develop.

The following four factors, often interrelated, contribute to erosion at the spillway outlet:

1. Flows emerging from the outlet are above the stream channel. If outlet flows emerge at the correct elevation, tailwater in the stream channel can absorb a substantial amount of the high velocity. The flow and the hydraulic energy will be contained in the stilling basin.
2. Flows emerging from the spillway are generally free of sediment and therefore have substantial sediment-carrying capacity. In taking on sediment, moving water will scour soil material from the channel and leave eroded areas. Such erosion is difficult to design for and requires protection of the outlet for a safe distance downstream from the dam.
3. Flows leaving the outlet at high velocity can create negative pressures that can cause material to come loose and separate from the floor and walls of the outlet channel. This process is called *cavitation* when it occurs on concrete or metal surfaces. Venting can sometimes be used to relieve negative pressures.
4. Water leaking through pipe joints or flowing along a pipe from the reservoir may weaken the soil structure around the pipe. Inadequate compaction adjacent to such structures during construction can compound this problem.

Deterioration of gates in spillways can result in an inability of the gates to

function during storm events. Causes of structural deterioration include, but are not limited to:

1. *Corrosion* can seriously weaken a structure or impair its operation. The effect of corrosion on the strength, stability, and serviceability of gates must be evaluated. A loss of cross-section in a member causes a reduction in strength and stiffness that leads to increased stress levels and deformation without any change in the imposed loading. Flexure, shear, and buckling strength may be affected. A buildup of corrosion products can be damaging at connection details. For example, corrosion buildup in a tainter gate trunnion can lead to extremely high hoist loads. Localized pitting corrosion can form notches that may serve as fracture initiation sites, which could significantly reduce the member's fatigue life.
2. *Fracture* usually initiates at a discontinuity that serves as a local stress raiser. Structural connections that are welded, bolted, or riveted are sources of discontinuities and stress concentrations.
3. *Fatigue* is the process of cumulative damage caused by repeated cyclic loading. Fatigue damage generally occurs at stress-concentrated regions where the localized stress exceeds the yield stress of the material. Fatigue is particularly a concern with spillway gates with vibration problems.
4. *Operation and maintenance.* Proper operation and maintenance of spillway gates are necessary to prevent structural deterioration. The following items are possible causes of structural deterioration.
 - a. Weld repairs are often sources of future cracking or fracture problems, particularly if the existing steel had poor weldability.
 - b. If moving connections are not lubricated properly, the bushings will

- wear and result in misalignment of the gate, resulting in wear of other parts and unforeseen loads.
 - c. Malfunctioning limit switches could result in detrimental loads and wear.
 - d. A coating system or cathodic protection that is not maintained can result in detrimental corrosion of metal components.
5. *Unforeseen loading.* Accidental overload or dynamic loading of a gate can result in deformed members or fracture. When structural members become deformed or buckled, they may have significantly reduced strength or otherwise impair the performance of the gate. Dynamic loading may be caused by hydraulic flow at the seals. Other unusual loadings may occur from malfunctioning limit switches or debris trapped at interfaces between moving parts. Unusual loads may also develop on gates supported by walls that are settling or moving. These unusual loads can cause overstressing and lead to deterioration.

Procedure for inspection—Spillway inspection is an important part of a dam-safety program. Its basic objective is to detect any sign of obstruction, erosion, deterioration, misalignment, or cracking.

An inspection of an earth spillway should determine whether side slopes have sloughed and whether there is excessive vegetation in the channel, and should look for signs of erosion and rodent activity. The inspector should also use a probe to determine the hardness and moisture content of the soil, note the location of particularly wet or soft spots, and see if the stilling basin or drop structure is properly protected with rocks or riprap. Because some erosion is unavoidable during spilling, an owner should also determine whether such erosion might endanger the embankment itself. If the spillway is installed with a sill or wall, a dam owner should also determine if there are any

cracks or misalignment in the sill or wall and check for erosion beneath of the sill or wall or downstream from it.

Hairline cracks are usually harmless. Large cracks should be carefully inspected and their location, width, length, and orientation noted. Deterioration should be determined. The concrete should be examined for exposure of reinforcing bars.

Spillway surfaces exposed to freeze-thaw cycles often suffer from surface spalling. Chemical action, corrosion of the reinforcement, movement, contamination, and unsound aggregates can also cause spalling. If spalling is extensive, the spalled area should be sketched or photographed, showing its length, width, and depth. The problem should be examined closely to see if the remaining concrete has deteriorated or if reinforcing bars are exposed. The concrete should be tapped with a tapping device or rock hammer to determine if voids exist below the surface. Shallow spalling should be examined from time to time to determine if it is becoming worse. Deep spalling should be repaired as soon as possible by an experienced contractor.

Walls of spillways are usually equipped with weep (or drain) holes. Occasionally spillway chute slabs are also equipped with weep holes. If all such holes are dry, the soil behind the wall or below the slab is probably dry as well. If some holes are draining while others are dry, the dry holes may be plugged by mud or mineral deposits. Plugged weep holes increase the chances for failure of retaining walls or chute slabs. The plugged holes should be probed to determine causes of blockage, and soil or deposits cleaned out to restore drainage. If that work is not successful, rehabilitate the drain system as soon as possible under the supervision of a professional engineer.

Spillway retaining walls and chute slabs are normally constructed in sections. Between adjoining sections, gaps or joints must be tightly sealed with flexible

materials such as tar, epoxies, or other chemical compounds. Sometimes rubber or plastic diaphragm materials or copper foil are used to obtain watertightness. During inspection, one should note the location, length, and depth of any missing sealant, and probe open gaps to determine if soil behind the wall or below the slab has been undermined.

Misalignment of spillway retaining walls or chute slabs may be caused by foundation settlement or earth or water pressure. The inspector should carefully look at the upstream or downstream end of a spillway near the wall to determine if it has been tipped inward or outward. Relative displacement or offset between neighboring sections can be readily identified at joints. The horizontal as well as vertical displacement should be measured. A fence on top of the retaining wall is usually erected in a straight line at the time of construction; thus any curve or distortion of the fence line may indicate wall deformation.

At the time of construction, the entire spillway chute should form a smooth surface. Thus, measurement of relative movement between neighboring chute slabs at joints will give a good indication of slab displacement. Misalignment or displacement of walls or the slab is often accompanied by cracks. A clear description of crack patterns should be recorded or photos taken to help in understanding the nature of the displacement.

The following areas should be inspected on all gates in spillways:

- main framing members and lifting and support assemblies
- locations susceptible to fracture or weld-related cracking
- corrosion-susceptible areas—normal waterline, abrasion areas, crevices, areas where water could stand
- lifting connections and chains or cables
- trunnions

- intersecting welds
- previous cracks repaired by welding
- locations of previous repairs or where damage has been reported
- seal plates

Figures 5.6 show potential problems with spillways, causes, possible consequences, and recommended action.

5.5 Inlets, Outlets, and Drains

A dam's inlet and outlet works, including internal drains, are essential to its operation. Items for inspection and special attention include:

- reservoir pool levels
- lake drains and internal drains
- Corrosion
- trashracks on pipe spillways
- cavitation

The topics discussed above for spillways also are relevant.

Reservoir pool levels are controlled by spillway gates, lake drain-and-release structures, or flashboards. Flashboards, sometimes used to permanently or temporarily raise the pool level of water supply reservoirs, should not be installed or allowed unless there is sufficient freeboard remaining to safely accommodate a design flood. Pool-level drawdown should not exceed about 1 foot per week for slopes composed of clay or silt materials except in an emergency. Very flat slopes or slopes with free-draining upstream soils can, however, withstand more rapid drawdown rates. Conditions causing or requiring temporary or permanent adjustment of the pool level include:

- A problem that requires lowering of the pool. Drawdown is a temporary solution until the problem is solved.
- Release of water downstream to supplement stream flow during dry conditions.

- Fluctuations in the service area's demand for water.
- Repair of boat docks in the winter and growth of aquatic vegetation along the shoreline.
- Requirements for recreation, hydro-power, or waterfowl and fish management.

Lake drains—A lake drain should always be operable so that the pool level can be drawn down in case of an emergency or for necessary repair. Lake-drain valves or gates that have not been operated for a long time can present a special problem for owners. If the valve cannot be closed after it is opened, the impoundment could be completely drained. An uncontrolled and rapid drawdown could also cause more serious problems such as slides along the saturated upstream slope of the embankment or downstream flooding. Therefore, when a valve or gate is operated, it should be inspected and all appropriate parts lubricated and repaired. It is also prudent to advise downstream residents of large or prolonged discharges.

Testing a valve or gate without risking complete drainage entails physically blocking the drain inlet upstream from the valve. Some drains have been designed with this capability and have dual valves or gates, or slots for stoplogs (sometimes called *bulkheads*) upstream from the valve. Otherwise, divers can be hired to inspect the drain inlet and may be able to construct a temporary block at the inlet. Since that could be dangerous, safety precautions are needed.

Other problems may be encountered when operating a lake drain. Sediment can build up and block the drain inlet, or debris can enter the valve chamber, hindering its function. The likelihood of these problems is greatly decreased if the valve or gate is operated and maintained on a schedule prepared by a professional engineer.

Corrosion is a common problem of pipe spillways and other conduits made of

metal. Exposure to moisture, acid conditions, or salt will accelerate corrosion. In particular, acid runoff from strip mine areas will cause rapid corrosion of steel pipes. In such areas, pipes made of noncorrosive materials such as concrete or plastic should be used. Metal pipes which have been coated to resist accelerated corrosion are also available. The coating can be of epoxy, aluminum, zinc (galvanization), asbestos or mortar. Coatings applied to pipes in service are generally not very effective because of the difficulty of establishing a bond. Similarly, bituminous coating cannot be expected to last more than one to two years on flow ways. Of course, corrosion of metal parts of operating mechanisms can be effectively treated and prevented by keeping those parts greased and/or painted.

Corrosion can also be controlled or arrested by installing cathodic protection. A sacrificial metallic anode made out of a material such as magnesium is buried in the soil and is connected to the metal pipe by wire. An electric potential is established which causes the magnesium to corrode and not the pipe.

Trash on pipe spillways. Many dams have pipe and riser spillways. As with concrete spillways, pipe inlets that become plugged with debris or trash reduce spillway capacity. As a result, the potential for overtopping is greatly increased, particularly if there is only one outlet. If a dam has an emergency spillway channel, a plugged principal spillway will cause more frequent, and greater than normal, flow in the emergency spillway; because emergency spillways are generally designed for infrequent flows of short duration, serious damage may result. For these reasons trash collectors or trashracks should be installed at the inlets to pipe spillways and lake drains.

A well-designed trashrack will stop large debris that could plug a pipe but allow unrestricted passage of water and smaller debris. Some of the most effective

racks have submerged openings which allow water to pass beneath the trash into the riser inlet as the pool level rises. Openings that are too small will stop small debris such as twigs and leaves, which in turn will cause a progression of larger items to build up, eventually completely blocking the inlet. Trashrack openings should be at least 6 inches across, regardless of the pipe size. The larger the principal spillway conduit, the larger the trashrack opening should be. The largest possible openings should be used, up to a maximum of about 2 feet. A trashrack should be properly attached to the riser inlet and strong enough to withstand the forces of fast-flowing debris, heavy debris, and ice. If the riser is readily accessible, vandals may throw riprap stone into it. The size of the trashrack openings should not be decreased to prevent this. Instead rock that is larger than the trashrack openings or too large to handle should be used for riprap.

Maintenance should include periodic checking of the trashrack for rusted and broken sections and repair as needed. The rack should be checked frequently during and after storms to ensure that it is functioning properly and to remove accumulated debris.

Cavitation. When water flows through an outlet system and passes restrictions (e.g., valves), the pressure may drop. If localized water pressures drop below the vapor pressure of water, a partial vacuum is created and the water actually boils, causing shock-waves which can damage the outlet pipes and control valves. This process can be a serious problem for large dams where discharge velocities are high.

Testing the outlet system. All valves should be fully opened and closed at least once a year. This not only limits corrosion buildup on control stems and gate guides, but also provides an opportunity to check for smooth operation of the system. Jerky or erratic operation could

signal problems, and indicate the need for more detailed inspection.

The full range of gate settings should be checked. The person performing the inspection should slowly open the valve, checking for noise and vibration—certain valve settings may result in greater turbulence. He or she should also listen for noise like gravel being rapidly transported through the system—this sound indicates cavitation and these gate settings should be avoided. The operation of all mechanical and electrical systems, backup electric motors, power generators, and power and lighting wiring associated with the outlet should also be checked.

Inspecting the outlet system. Accessible portions of the outlet, such as the outfall structure and control, can be inspected easily and regularly. However, severe problems are commonly associated with deterioration or failure of portions of the system either buried in the dam or normally under water.

- Outlet pipes 30 inches or greater in diameter can be inspected internally, provided the system has an upstream valve allowing the pipe to be emptied. Tapping the conduit interior with a hammer can help locate voids behind the pipe. This type of inspection should be performed at least once a year.
- Small-diameter outlet pipes can be inspected by remote TV camera if necessary. The camera is channeled through the conduit and transmits a picture back to an equipment truck. This type of inspection is expensive and usually requires the services of an engineer. However, if no other method of inspection is possible, inspection by TV is recommended at least once every five years.
- Outlet intake structures, wet wells, and outlet pipes with only downstream valves are the most difficult dam appurtenances to inspect because they are usually under water. These should

be inspected whenever the reservoir is drawn down or at five-year intervals. If a definite problem is suspected, or if the reservoir remains full over extended periods, divers should be hired to perform an underwater inspection.

Figures 5.7 show potential problems with inlets, outlets, and drains, causes, possible consequences, and recommended action.

5.6 General Areas

Other areas requiring inspection include:

- mechanical and electrical systems
- the reservoir surface and shoreline
- the upstream watershed
- downstream floodplains

Mechanical equipment includes spillway gates, sluice gates or valves for lake drains or water supply pipes, stoplogs, sump pumps, flashboards, relief wells,

emergency power sources, siphons, and other devices. All mechanical and associated electrical equipment should be operated at least once a year and preferably more often. The test should cover the full operating range of the equipment under actual operating conditions. Each operating device should be permanently marked for easy identification, and all operating equipment should be kept accessible. All controls should be checked for proper security to prevent vandalism or malicious intent, and finally, all operating instructions should be checked for clarity and maintained in a secure, but readily accessible, location.

The reservoir surface and shoreline should be inspected to identify possible problems away from the actual structure. Whirlpools can indicate submerged outlets. Large landslides into the reservoir could cause waves to overtop the dam.

Floods arise from the upstream watershed. Therefore, characteristics of the watershed, such as impervious areas (e.g., parking lots), relate directly to the magnitude of a flood. Urban development in a watershed can increase the size of flood peaks and the volume of runoff, making a previously acceptable spillway inadequate. Awareness of upstream development and other factors that might influence reservoir inflows is important in order to determine the necessity for any modifications to the dam or spillways.

Development in downstream floodplains is also very important to the dam owner as the extent of development and flood preparedness relates directly to loss of life and damages should the dam fail. Downstream development may raise the hazard rating of the dam; therefore, it should be accounted for during annual assessments.

(Chapter figures on following pages.)

Figure 5.1
Inspection Guidelines - Upstream Slope

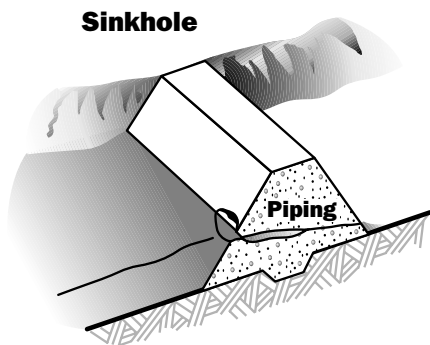

Figure 5.1a

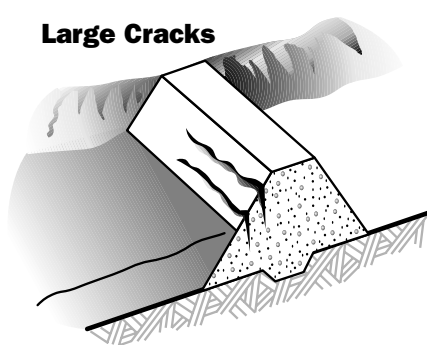

Figure 5.1b

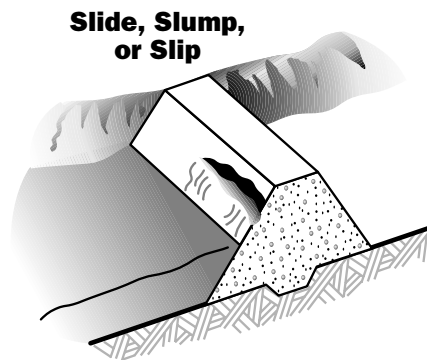

Figure 5.1c

Problem	Probable Cause and Possible Consequences	Recommended Actions
<p>Sinkhole <i>(Figure 5.1a)</i></p>	<p>Piping or internal erosion of embankment materials or foundation causes a sinkhole. The cave-in of an eroded cavern can result in a sinkhole. A small hole in the wall of an outlet pipe can develop into a sinkhole. Dirty water at the exit indicates erosion of the dam.</p> <p>Piping can empty a reservoir through a small hole in the wall or can lead to failure of a dam as soil pipes erode through the foundation or a pervious part of the dam. Dispersive soils are particularly susceptible to sinkholes.</p>	<p>Inspect other parts of the dam for seepage or more sinkholes. Check seepage and leakage outflows for dirty water. A qualified engineer should inspect the conditions, identify the exact cause of sinkholes, and recommend further actions. Depending on the location in the embankment, the reservoir may need to be drawn down.</p> <p>ENGINEER REQUIRED</p>
<p>Large Cracks <i>(Figure 5.1b)</i></p>	<p>A portion of the embankment has moved because of loss of strength, or the foundation may have moved, causing embankment movement.</p> <p>Indicates onset of massive slide or settlement caused by foundation failure.</p>	<p>Depending on embankment involved, draw reservoir level down. A qualified engineer should inspect the condition and recommend further actions.</p> <p>ENGINEER REQUIRED</p>
<p>Slide, Slump, or Slip <i>(Figure 5.1c)</i></p>	<p>Earth or rocks move down the slope along a slippage surface because of too steep a slope, or the foundation moves. Also, look for slide movements in reservoir basin. A series of slides can lead to obstruction of the inlet or failure of the dam.</p>	<p>Evaluate extent of the slide. Monitor slide. (See Chapter 6.) Draw the reservoir level down if safety of dam is threatened. A qualified engineer should inspect the conditions and recommend further actions.</p> <p>ENGINEER REQUIRED</p>

**Figure 5.1 (cont.)
Inspection Guidelines - Upstream Slope**

**Broken Down
Missing Riprap**

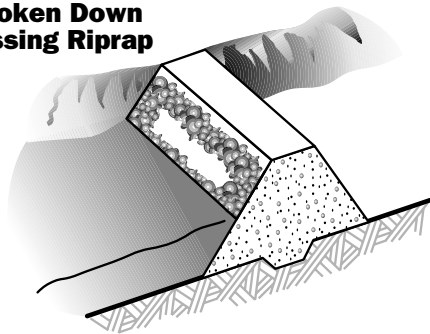

Figure 5.1d

**Erosion Behind
Poorly Graded Riprap**

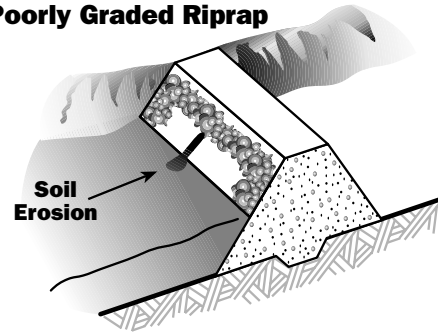

Figure 5.1e

Problem	Probable Cause and Possible Consequences	Recommended Actions
<p>Scarps, Benches, Oversteep Areas</p>	<p>Wave action, local settlement, or ice action cause soil and rock to erode and slide to the lower part of the slope, forming a bench.</p> <p>Erosion lessens the width and possible height of the embankment and could lead to seepage or overtopping of the dam.</p>	<p>Determine exact cause of scarps. Do necessary earthwork, restore embankment to original slope, and supply adequate protection (bedding and riprap). (See Chapter 7.)</p>
<p>Broken Down, Missing Riprap <i>(Figure 5.1d)</i></p>	<p>Poor-quality riprap has deteriorated. Wave action or ice action has displaced riprap. Round and similar-sized rocks have rolled downhill.</p> <p>Wave action against these unprotected areas decreases embankment width.</p>	<p>Reestablish normal slope. Place bedding and competent riprap. (See Chapter 7.)</p>
<p>Erosion Behind Poorly Graded Riprap <i>(Figure 5.1e)</i></p>	<p>Similar-sized rocks allow waves to pass between them and erode small gravel particles and soil.</p> <p>Soil is eroded away from behind the riprap. This allows riprap to settle, offering less protection and decreased embankment width.</p>	<p>Reestablish effective slope protection. Place bedding material.</p> <p>ENGINEER REQUIRED for design—for graduation and size for rock for bedding and riprap. A qualified engineer should inspect the conditions and recommend further actions.</p>

Figure 5.2
Inspection Guidelines - Downstream Slope

Slide/Slough

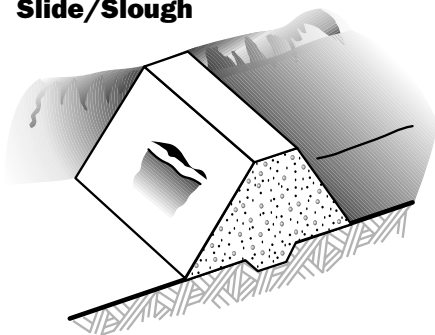

Figure 5.2a

Transverse Cracking

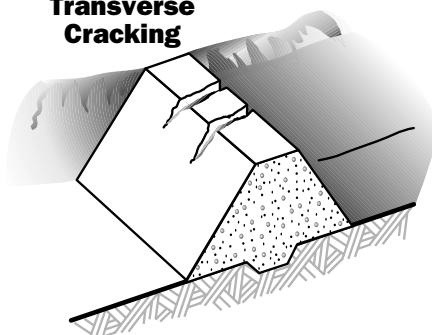

Figure 5.2b

Cave In/ Collapse

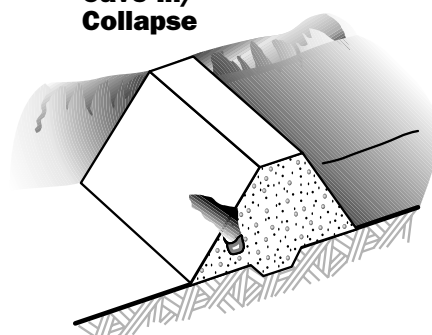

Figure 5.2c

Problem	Probable Cause and Possible Consequences	Recommended Actions
<p>Slide or Slough <i>(Figure 5.2a)</i></p>	<p>Lack loss of strength of embankment material. Loss of strength can be attributed to infiltration of water into the embankment or loss of support by the foundation.</p> <p>Massive slide cuts through crest or upstream slope reducing freeboard and cross-section. Structural collapse or overtopping can result</p>	<ol style="list-style-type: none"> 1. Measure extent and displacement of slide. If continued movement is seen, begin lowering water level until movement stops. 2. Have a qualified engineer inspect the condition and recommend further action. <p>ENGINEER REQUIRED</p>
<p>Transverse Cracking <i>(Figure 5.2b)</i></p>	<ol style="list-style-type: none"> 1. Uneven movement between adjacent segments of the embankment. 2. Deformation caused by structural stress or instability. <ol style="list-style-type: none"> 1. Can provide a path for seepage through the embankment cross-section. 2. Provides local area of low strength within embankment. Future structural movement, deformation or failure could begin. 3. Provides entrance point for surface runoff to enter embankment 	<ol style="list-style-type: none"> 1. Inspect crack and carefully record crack location, length, depth, width and other pertinent physical features. Stake out limits of cracking. Engineer should determine cause of cracking and supervise all steps necessary to reduce danger to dam and correct condition. 2. Excavate slope along crack to a point below the bottom of the crack. Then, backfill excavation using competent material and correct construction techniques. This will seal the crack against seepage and surface runoff. This should be supervised by engineer. Continue to monitor crest routinely for evidence of future cracking. <p>ENGINEER REQUIRED</p>
<p>Cave-in or Collapse <i>(Figure 5.2c)</i></p>	<ol style="list-style-type: none"> 1. Lack of adequate compaction. 2. Rodent hole below. 3. Piping through embankment or foundation. 4. Presence of dispersive soils. <p>Indicates possible washout of embankment.</p>	<ol style="list-style-type: none"> 1. Inspect for and immediately repair rodent holes. Control rodents to prevent future damage. 2. Have a qualified engineer inspect the condition and recommend further action. <p>ENGINEER REQUIRED</p>

**Figure 5.2 (cont.)
Inspection Guidelines - Downstream Slope**

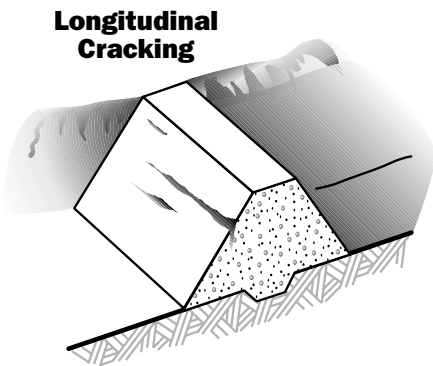

Figure 5.2d

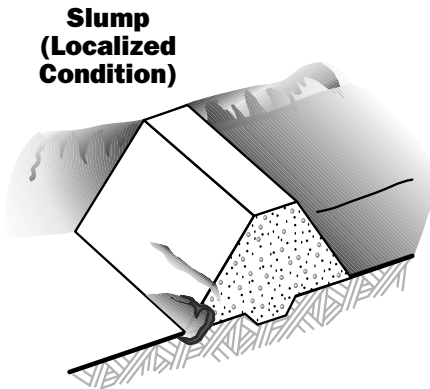

Figure 5.2e

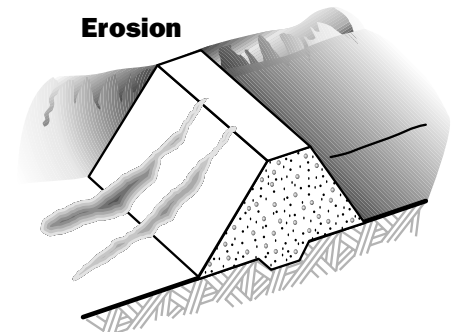

Figure 5.2f

Problem	Probable Cause and Possible Consequences	Recommended Actions
<p>Longitudinal Cracking <i>(Figure 5.2d)</i></p>	<ol style="list-style-type: none"> 1. Drying and shrinkage of surface material. 2. Downstream movement or settlement of embankment. <ol style="list-style-type: none"> 1. Can be an early warning of a potential slide. 2. Shrinkage cracks allow water to enter the embankment and freezing will further crack the embankment. 3. Settlement or slide, showing loss of strength in embankment that can lead to failure. 	<ol style="list-style-type: none"> 1. If cracks are from drying, dress area with well-compacted material to keep surface water out and natural moisture in. 2. If cracks are extensive, a qualified engineer should inspect the condition and recommend further actions. <p>ENGINEER REQUIRED</p>
<p>Slump (localized condition) <i>(Figure 5.2e)</i></p>	<p>Preceded by erosion undercutting a portion of the slope. Can also be found on steep slopes.</p> <p>Can expose impervious zone to erosion and lead to additional slumps.</p>	<ol style="list-style-type: none"> 1. Inspect area for seepage. 2. Monitor for progressive failure. 3. Have a qualified engineer inspect the condition and recommend further action. <p>ENGINEER REQUIRED</p>
<p>Erosion <i>(Figure 5.2f)</i></p>	<p>Water from intense rainstorms or snowmelt carries surface material down the slope, resulting in continuous troughs.</p> <p>Can be hazardous if allowed to continue. Erosion can lead to eventual deterioration of the downstream slope and failure of the structure.</p>	<ol style="list-style-type: none"> 1. The preferred method to protect eroded areas is rock or riprap. 2. Reestablishing protective grasses can be adequate if the problem is detected early.

**Figure 5.2 (cont.)
Inspection Guidelines - Downstream Slope**

**Trees/
Obscuring Brush**

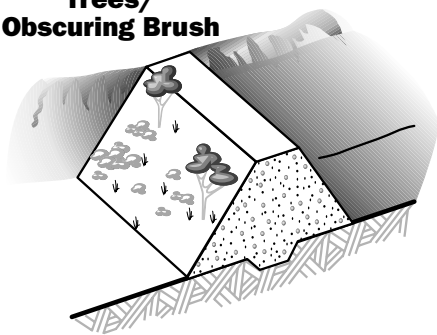

Figure 5.2g

**Rodent
Activity**

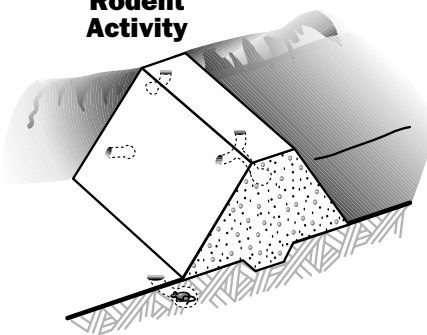

Figure 5.2h

**Livestock/
Cattle Traffic**

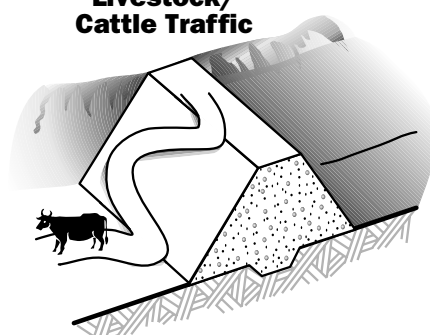

Figure 5.2i

Problem	Probable Cause and Possible Consequences	Recommended Actions
<p>Trees, Obscuring Brush (Figure 5.2g)</p>	<p>Natural vegetation in area.</p> <p>Large tree roots can create seepage paths. Large trees can blow over during storms and damage dam or cause breach. Bushes can obscure visual inspection and harbor rodents.</p>	<ol style="list-style-type: none"> 1. Remove all brush and trees less than 4" in diameter. Larger trees may be allowed to stay until they die. At that time, the tree, with its root system, should be removed and the void properly filled with compacted soil. (See Chapter 7.) 2. Control vegetation on the embankment that obscures visual inspection. (See Chapter 7.)
<p>Rodent Activity (Figure 5.2h)</p>	<p>Overabundance of rodents. Animal burrowing creates holes, tunnels, and caverns. Certain habitats, such as cattail-filled areas and trees close to the reservoir encourage these animals.</p> <p>Can reduce length of seepage path and lead to piping failure. If tunnel runs through most of the dam, it can lead to collapse.</p>	<ol style="list-style-type: none"> 1. Control rodents to prevent more damage. 2. Backfill existing rodent holes. 3. Remove rodents. Determine exact location and extent of tunneling. Remove habitat and repair damages. (See Chapter 7.)
<p>Livestock (such as cattle) Traffic (Figure 5.2i)</p>	<p>Excessive travel by livestock especially harmful to slope when wet.</p> <p>Creates areas bare of erosion protection and causes erosion channels. Allows water to stand. Area susceptible to drying cracks.</p>	<ol style="list-style-type: none"> 1. Fence livestock outside embankment area. 2. Repair erosion protection, i.e. riprap, grass.

Figure 5.3
Inspection Guidelines - Embankment Crest

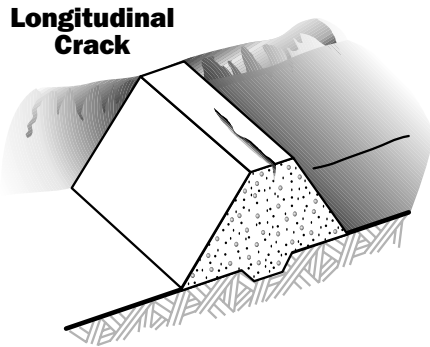

Figure 5.3a

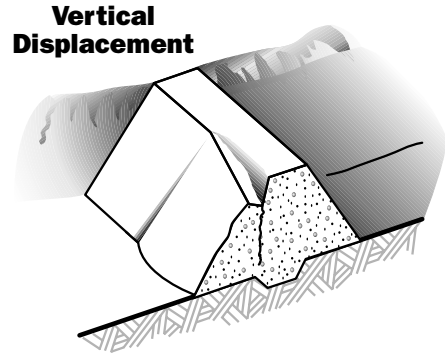

Figure 5.3b

Problem	Probable Cause and Possible Consequences	Recommended Actions
<p>Longitudinal Crack <i>(Figure 5.3a)</i></p>	<ol style="list-style-type: none"> 1. Uneven settlement between adjacent sections or zones within the embankment. 2. Foundation failure causing loss of support to embankment. 3. Initial stages of embankment slide. <ol style="list-style-type: none"> 1. Creates local area of low strength within an embankment. Could be the point of initiation of future structural movement, deformation or failure. 2. Provides entrance point for surface runoff into embankment, allowing saturation of adjacent embankment area and possible lubrication which could lead to localized failure. 	<ol style="list-style-type: none"> 1. Inspect crack and carefully record location, length, depth, width, alignment, and other pertinent physical features. Immediately stake out limits of cracking. Monitor frequently. 2. Engineer should determine cause of cracking and supervise steps necessary to reduce danger to dam and correct condition. 3. Effectively seal the cracks at the crest surface to prevent infiltration by surface water. 4. Continue to routinely monitor crest for evidence of further cracking. <p>ENGINEER REQUIRED</p>
<p>Vertical Displacement <i>(Figure 5.3b)</i></p>	<ol style="list-style-type: none"> 1. Vertical movement between adjacent sections of the embankment. 2. Structural deformation or failure caused by structure stress or instability, or by failure of the foundation. <ol style="list-style-type: none"> 1. Creates local area of low strength within embankment which could cause future movement. 2. Leads to structural instability or failure. 3. Creates entrance point for surface water that could further lubricate failure plane. 4. Reduces available embankment cross-section. 	<ol style="list-style-type: none"> 1. Carefully inspect displacement and record its location, vertical and horizontal displacement, length and other physical features. Immediately stake out limits of cracking. 2. Engineer should determine cause of displacement and supervise all steps necessary to reduce danger to dam and correct condition. 3. Excavate area to the bottom of the displacement. Backfill excavation using competent material and correct construction techniques, under supervision of engineer. 4. Continue to monitor areas routinely for evidence of cracking or movement. (See Chapter 6.) <p>ENGINEER REQUIRED</p>

**Figure 5.3 (cont.)
Inspection Guidelines - Embankment Crest**

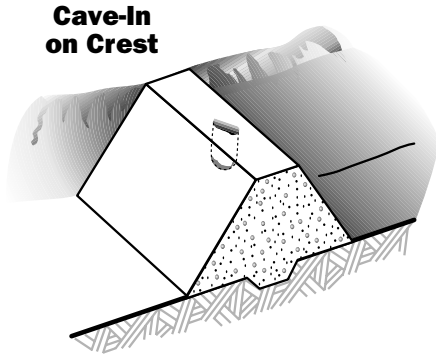

Figure 5.3c

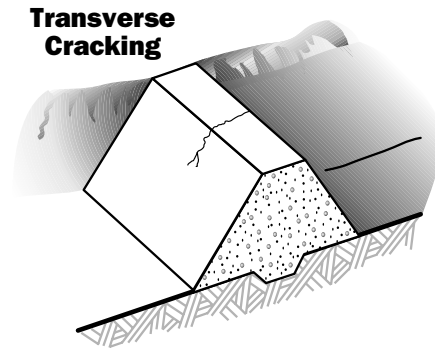

Figure 5.3d

Problem	Probable Cause and Possible Consequences	Recommended Actions
<p>Cave-in On Crest (Figure 5.3c)</p>	<ol style="list-style-type: none"> 1. Rodent activity. 2. Hole in outlet conduit is causing erosion of embankment material. 3. Internal erosion or piping of embankment material by seepage. 4. Breakdown of dispersive clays within embankment by seepage waters. <ol style="list-style-type: none"> 1. Void within dam could cause localized caving, sloughing, instability or reduced embankment cross-section. 2. Entrance point for surface water. 	<ol style="list-style-type: none"> 1. Carefully inspect and record location and physical characteristics (depth, width, length) of cave-in. 2. Engineer should determine cause of cave-in and supervise all steps necessary to reduce threat to dam and correct condition. 3. Excavate cave-in, slope sides of excavation and backfill hole with competent material using proper construction techniques. (See Chapter 7.) This should be supervised by engineer. <p>ENGINEER REQUIRED</p>
<p>Transverse Cracking (Figure 5.3d)</p>	<ol style="list-style-type: none"> 1. Uneven movement between adjacent segments of the embankment. 2. Deformation caused by structural stress or instability. <ol style="list-style-type: none"> 1. Can provide a path for seepage through the embankment cross-section. 2. Provides local area of low strength within embankment. Future structural movement, deformation or failure could begin. 3. Provides entrance point for surface runoff to enter embankment. 	<ol style="list-style-type: none"> 1. Inspect crack and carefully record crack location, length, depth, width and other pertinent physical features. Stake out limits of cracking. 2. Engineer should determine cause of cracking and supervise all steps necessary to reduce danger to dam and correct condition. 3. Excavate crest along crack to a point below the bottom of the crack. Then backfilling excavation using competent material and correct construction techniques. This will seal the crack against seepage and surface runoff. (See Chapter 7.) This should be supervised by engineer. 4. Continue to monitor crest routinely for evidence of future cracking. (See Chapter 4.) <p>ENGINEER REQUIRED</p>

**Figure 5.3 (cont.)
Inspection Guidelines - Embankment Crest**

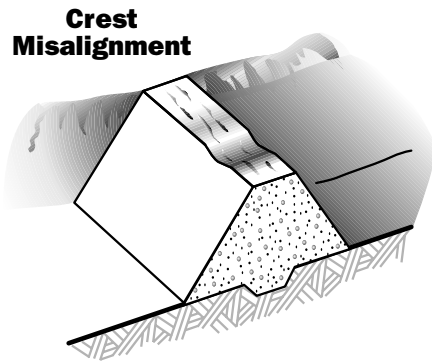

Figure 5.3e

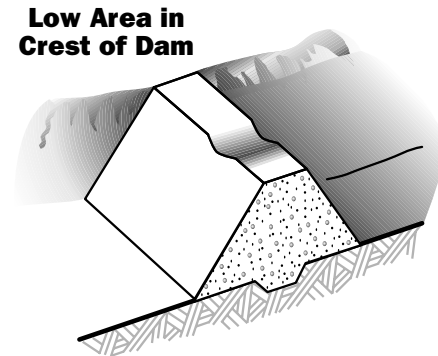

Figure 5.3f

Problem	Probable Cause and Possible Consequences	Recommended Actions
<p>Crest Misalignment <i>(Figure 5.3e)</i></p>	<ol style="list-style-type: none"> 1. Movement between adjacent parts of the structure. 2. Uneven deflection of dam under loading by reservoir. 3. Structural deformation or failure near area of misalignment. <ol style="list-style-type: none"> 1. Area of misalignment is usually accompanied by low area in crest which reduces freeboard. 2. Can produce local areas of low embankment strength which may lead to failure. 	<ol style="list-style-type: none"> 1. Establish monuments across crest to determine exact amount, location, and extent of misalignment. 2. Engineer should determine cause of misalignment and supervise all steps necessary to reduce threat to dam and correct condition. 3. Following remedial action, monitor crest monuments according to a schedule to detect any movement. (See Chapter 6.) <p>ENGINEER REQUIRED</p>
<p>Low Area in Crest <i>(Figure 5.3f)</i></p>	<ol style="list-style-type: none"> 1. Excessive settlement in the embankment or foundation directly beneath the low area in the crest. 2. Internal erosion of embankment material. 3. Foundation spreading to upstream and/or downstream direction. 4. Prolonged wind erosion of crest area. 5. Improper final grading following construction. <p>Reduces freeboard available to pass flood flows safely through spillway.</p>	<ol style="list-style-type: none"> 1. Establish monuments along length of crest to determine exact amount, location, and extent of settlement in crest. 2. Engineer should determine cause of low area and supervise all steps necessary to reduce possible threat to the dam and correct condition. 3. Reestablish uniform crest elevation over crest length by filling in low area using proper construction techniques. This should be supervised by engineer. 4. Reestablish monuments across crest of dam and routinely monitor monuments to detect any settlement. <p>ENGINEER REQUIRED</p>

**Figure 5.3 (cont.)
Inspection Guidelines - Embankment Crest**

**Obscuring
Vegetation**

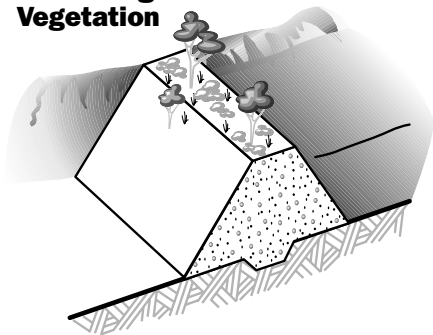

Figure 5.3g

**Rodent
Activity**

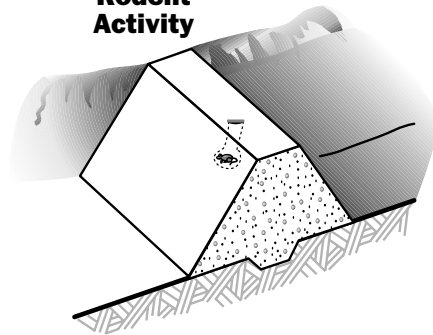

Figure 5.3h

Problem	Probable Cause and Possible Consequences	Recommended Actions
<p>Obscuring Vegetation (Figure 5.3g)</p>	<p>Neglect of dam and lack of proper maintenance procedures.</p> <ol style="list-style-type: none"> 1. Obscures large parts of the dam, preventing adequate, accurate visual inspection of all parts of the dam. Problems which threaten the integrity of the dam can develop and remain undetected until they progress to a point that threatens the dam's safety. 2. Associated root systems develop and penetrate into the dam's cross-section. When the vegetation dies, the decaying root systems can provide paths for seepage. This reduces the effective seepage path through the embankment and could lead to possible piping situations. 3. Prevents easy access to all parts of the dam for operation, maintenance and inspection. 4. Provides habitat for rodents. 5. Large trees can blow over during storms, resulting in damage and possible breach of the dam. 	<ol style="list-style-type: none"> 1. Remove all damaging growth from the dam. This would include removal of trees (4-inches or less in diameter), bushes, brush, conifers and growth other than grass. Grass should be encouraged on all segments of the dam to prevent erosion by surface runoff. Root systems should also be removed to the maximum practical extent. The void which results from removing the root system should back-filled with well-competent, well-compacted material. 2. Future undesirable growth should be removed by cutting or spraying, as part of an annual maintenance program. (See Chapter 7.) 3. All cutting or debris resulting from the vegetative removal should be immediately taken from the dam and properly disposed of outside the reservoir basin. An engineer should be involved if the tree removal process poses a threat to the dam.

Rodent Activity
(Figure 5.3h)

Burrowing animals.

1. Entrance point for surface runoff to enter dam. Could saturate adjacent portions of the dam.
2. Especially dangerous if hole penetrates dam below phreatic line. During periods of high storage, seepage path through the dam would be greatly reduced and a piping situation could develop. Tunnels can lead to collapse of crest and possible failure.

1. Completely backfill the hole with competent well-compacted material.
2. Initiate a rodent control program to reduce the burrowing animal population and to prevent future damage to the dam. (See Chapter 7.)

**Figure 5.3 (cont.)
Inspection Guidelines - Embankment Crest**

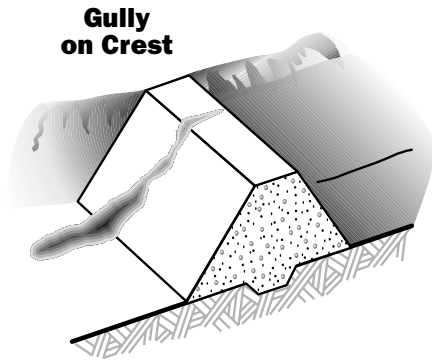

Figure 5.3i

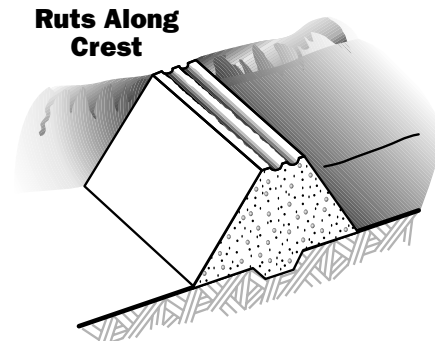

Figure 5.3j

Problem	Probable Cause and Possible Consequences	Recommended Actions
<p>Gully on Crest <i>(Figure 5.3i)</i></p>	<p>1. Poor grading and improper drainage of crest. Improper drainage causes surface runoff to collect and drain off crest at low point in upstream or downstream shoulder.</p> <p>2. Inadequate spillway capacity which has caused dam to overtop.</p> <p>1. Can reduce available freeboard.</p> <p>2. Reduces cross-sectional area of dam.</p> <p>3. Inhibits access to all parts of the crest and dam.</p> <p>4. Can result in a hazardous condition if due to overtopping.</p>	<p>1. Restore freeboard to dam by adding fill material to low area, using proper construction techniques. (See Chapter 7.)</p> <p>2. Regrading crest to provide proper drainage of surface runoff.</p> <p>3. If gully was caused by overtopping, create adequate spillway that meets current design standards. This should be done by engineer.</p> <p>4. Reestablish protective cover.</p>
<p>Ruts Along Crest <i>(Figure 5.3j)</i></p>	<p>Heavy vehicle traffic without adequate or proper maintenance or proper crest surfacing</p> <p>1. Inhibits easy access to all parts of crest.</p> <p>2. Allows continued development of rutting.</p> <p>3. Allows standing water to collect and saturate crest of dam.</p> <p>4. Operating and maintenance vehicles can get stuck.</p>	<p>1. Drain standing water from ruts.</p> <p>2. Regrade and re-compact crest to restore integrity and provide proper drainage to upstream slope. (See Chapter 7.)</p> <p>3. Provide gravel or roadbase material to accommodate traffic.</p> <p>4. Periodically maintain and regrade to prevent ruts reforming.</p>

**Figure 5.3 (cont.)
Inspection Guidelines - Embankment Crest**

**Puddling on Crest—
Poor Drainage**

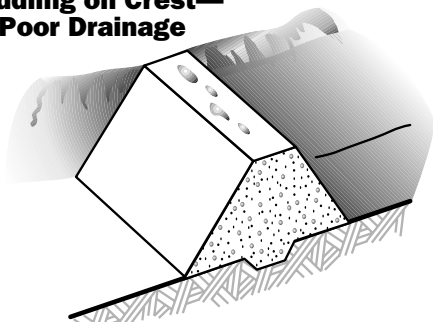

Figure 5.3k

**Drying
Cracks**

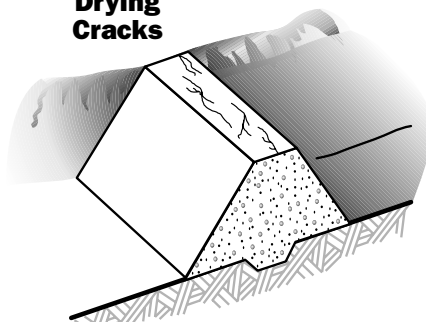

Figure 5.3l

Problem	Probable Cause and Possible Consequences	Recommended Actions
<p>Puddling on Crest— Poor Drainage <i>(Figure 5.3k)</i></p>	<ol style="list-style-type: none"> 1. Poor grading and improper drainage of crest. 2. Localized consolidation or settlement on crest allows puddles to develop. <ol style="list-style-type: none"> 1. Causes localized saturation of the crest. 2. Inhibits access to all parts of the dam and crest. 3. Becomes progressively worse if not corrected. 	<ol style="list-style-type: none"> 1. Drain standing water from puddles. 2. Regrade and re-compact crest to restore integrity and provide proper drainage to upstream slope. (See Chapter 7.) 3. Provide gravel or roadbase material to accommodate traffic. 4. Periodically maintain and regrade to prevent low areas reforming.
<p>Drying Cracks <i>(Figure 5.3l)</i></p>	<p>Material on the crest of dam expands and contracts with alternate wetting and drying of weather cycles. Drying cracks are usually short, shallow, narrow, and numerous.</p> <p>Point of entry for surface runoff and surface moisture, causing saturation of adjacent embankment areas. This saturation, and later drying of the dam, could cause further cracking.</p>	<ol style="list-style-type: none"> 1. Seal surface cracks with a tight, impervious material. (See Chapter 7.) 2. Routinely grade crest to proper drainage and fill cracks. 3. Cover crest with non-plastic material (not clay) to prevent large variations in moisture content.

Figure 5.4

Inspection Guidelines - Embankment Seepage Areas

Excessive Quantity and/or Muddy Water Exiting From a Point

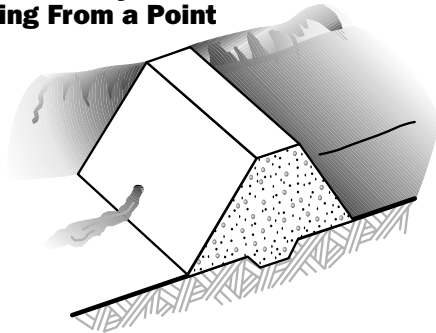

Figure 5.4a

Stream of Water Exiting Through Cracks Near the Crest

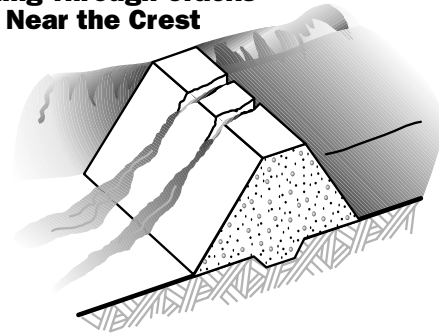

Figure 5.4b

Problem	Probable Cause and Possible Consequences	Recommended Actions
<p>Excessive Quantity and/or Muddy Water Exiting From a Point <i>(Figure 5.4a)</i></p>	<ol style="list-style-type: none"> 1. Water has created an open pathway, channel or pipe through the dam. The water is eroding and carrying embankment material. 2. Large amounts of water have accumulated in the downstream slope. Water and embankment materials are exiting at one point. Surface agitation may be causing the muddy water. 3. Rodents, frost action or poor construction have allowed water to create an open pathway or pipe through the embankment. 	<ol style="list-style-type: none"> 1. Begin measuring outflow quantity and establishing whether water is getting muddier, staying the same or clearing up. 2. If quantity of flow is increasing, water level in reservoir should be lowered until flow stabilizes or stops. 3. Search for opening on upstream side and plug if possible. 4. A qualified engineer should inspect the condition and recommend further actions to be taken. <p>ENGINEER REQUIRED</p>
<p>Stream of Water Exiting Through Cracks Near the Crest <i>(Figure 5.4b)</i></p>	<ol style="list-style-type: none"> 1. Severe drying has caused shrinkage of embankment material. 2. Settlement in the embankment or foundation is causing the transverse cracks. <p>Flow through the crack can cause failure of the dam.</p>	<ol style="list-style-type: none"> 1. Plug upstream side of crack to stop flow. 2. Lower water level in the reservoir should be lowered until below level of cracks. 3. A qualified engineer should inspect the condition and recommend further actions. <p>ENGINEER REQUIRED</p>

Figure 5.4 (cont.)
Inspection Guidelines - Embankment Seepage Areas

Seepage Water Exiting as a Boil in the Foundation

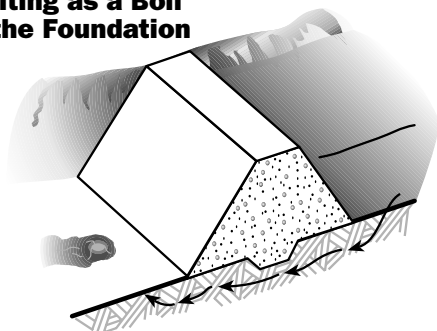

Figure 5.4c

Seepage Exiting at Abutment Contact

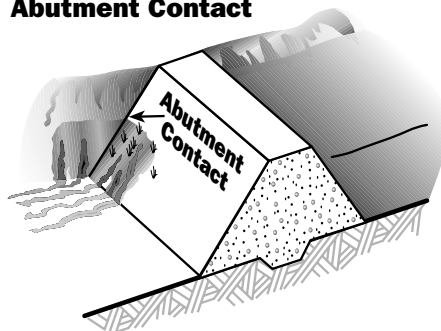

Figure 5.4d

Problem	Probable Cause and Possible Consequences	Recommended Actions
<p>Seepage Water Exiting as a Boil in the Foundation (Figure 5.4c)</p>	<p>Some part of the foundation material is supplying a flow path. This could be caused by a sand or gravel layer in the foundation. Increased flows can lead to erosion of the foundation and failure of the dam.</p>	<ol style="list-style-type: none"> 1. Examine the boil for transportation of foundation materials. 2. If soil particles are moving downstream, sandbags or earth should be used to create a dike around the boil. The pressures created by the water level with the dike may control flow velocities and temporarily prevent further erosion. 3. If erosion is becoming greater, the reservoir level should be lowered. 4. A qualified engineer should inspect the condition and recommend further actions. <p>ENGINEER REQUIRED</p>

Seepage Exiting at Abutment Contact
 (Figure 5.4d)

1. Water flowing through pathways in the abutment.
 2. Water flowing through the embankment.
 Can lead to erosion of embankment materials and failure of the dam.

1. Study leakage area to determine quantity of flow and extent of saturation.
2. Inspect daily for developing slides.
3. Water level in reservoir may need to be lowered to assure the safety of the embankment.
4. A qualified engineer should inspect the condition and recommend further actions.

ENGINEER REQUIRED

**Figure 5.4 (cont.)
Inspection Guidelines - Embankment Seepage Areas**

Large Area Wet or Producing Flow

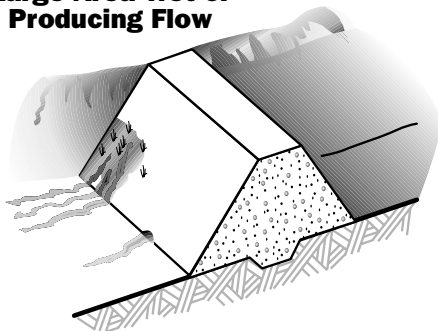

Figure 5.4e

Marked Change in Vegetation

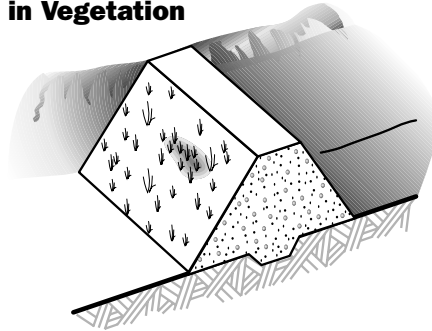

Figure 5.4f

Bulge in Large Wet Area

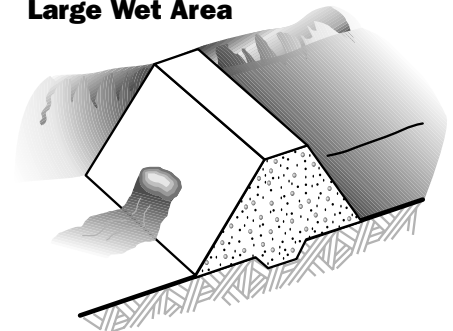

Figure 5.4g

Problem	Probable Cause and Possible Consequences	Recommended Actions
<p>Large Area Wet or Producing Flow <i>(Figure 5.4e)</i></p>	<p>A seepage path has developed through the abutment or embankment materials and failure of the dam can occur.</p> <ol style="list-style-type: none"> 1. Increased flows could lead to erosion of embankment material and failure of the dam. 2. Saturation of the embankment can lead to local slides which could cause failure of the dam. 	<ol style="list-style-type: none"> 1. Stake out the saturated area and monitor for growth or shrinking. 2. Measure any outflows as accurately as possible. 3. Reservoir level may need to be lowered if saturated areas grow at a fixed storage level or if flow increases. 4. A qualified engineer should inspect the condition and recommend further actions. <p>ENGINEER REQUIRED</p>
<p>Marked Change in Vegetation <i>(Figure 5.4f)</i></p>	<ol style="list-style-type: none"> 1. Embankment materials are supplying flow paths. 2. Natural seeding by wind. 3. Change in seed type during early post-construction seeding. <p>Can show a saturated area.</p>	<ol style="list-style-type: none"> 1. Use probe and shovel to establish if the materials in this area are wetter than surrounding areas. 2. If area shows wetness, when surrounding areas are dry or drier, a qualified engineer should inspect the condition and recommend further actions. <p>ENGINEER REQUIRED</p>
<p>Bulge in Large Wet Area <i>(Figure 5.4g)</i></p>	<p>Downstream embankment materials have begun to move.</p> <p>Failure of the embankment resulting from massive sliding can follow these early movements.</p>	<ol style="list-style-type: none"> 1. Compare embankment cross-section to the end of construction condition to see if observed condition may reflect end of construction. 2. Stake out affected area and accurately measure outflow. 3. A qualified engineer should inspect the condition and recommend further actions. <p>ENGINEER REQUIRED</p>

**Figure 5.4 (cont.)
Inspection Guidelines - Embankment Seepage Areas**

**Trampoline Effect
in Large Soggy Area**

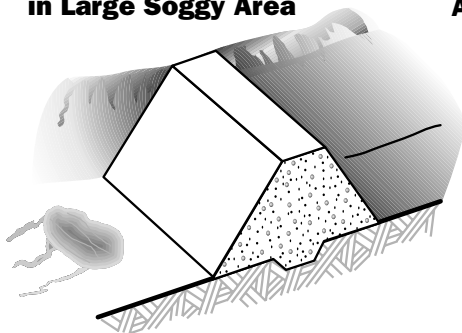

Figure 5.4h

**Leakage From
Abutments Beyond
the Dam**

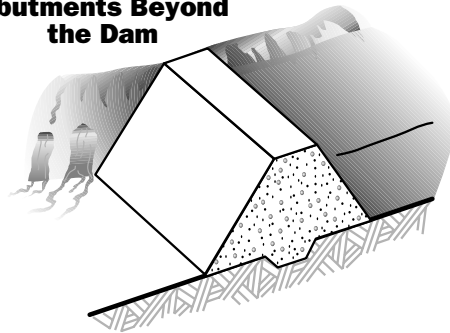

Figure 5.4i

**Wet Area in
Horizontal Band**

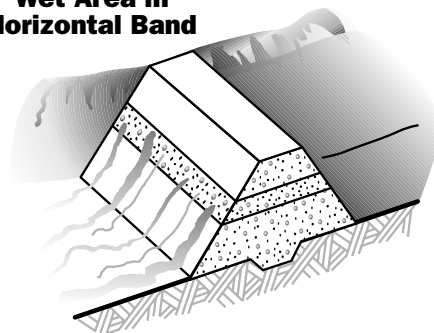

Figure 5.4j

Problem	Probable Cause and Possible Consequences	Recommended Actions
<p>Trampoline Effect (bouncy when jumped on) in Large Soggy Area (Figure 5.4h)</p>	<p>Water moving rapidly through the embankment or foundation is being controlled or contained by a well-established turf root system.</p> <p>Condition shows excessive seepage in the area. If control layer of turf is destroyed, rapid erosion of foundation materials could result in failure of the dam.</p>	<ol style="list-style-type: none"> Carefully inspect the area for outflow quantity and any transported material. A qualified engineer should inspect the condition and recommend further actions. <p>ENGINEER REQUIRED</p>
<p>Leakage From Abutments Beyond the Dam (Figure 5.4i)</p>	<p>Water moving through cracks and fissures in the abutment materials.</p> <p>Can lead to rapid erosion of abutment and evacuation of the reservoir. Can lead to massive slides near or downstream from the dam.</p>	<ol style="list-style-type: none"> Carefully inspect the area to determine quantity of flow and amount of transported material. A qualified engineer or geologist should inspect the condition and recommend further actions. <p>ENGINEER REQUIRED</p>
<p>Wet Area in Horizontal Band (Figure 5.4j)</p>	<p>Frost layer or layer of sandy material in original construction.</p> <ol style="list-style-type: none"> Wetting of areas below the area of excessive seepage can lead to localized instability of the embankment, resulting in slides. Excessive flows can lead to accelerated erosion of embankment materials and failure of the dam. 	<ol style="list-style-type: none"> Determine as closely as possible the flow being produced. If flow increases, reservoir level should be reduced until flow stabilizes or stops. Stake out the exact area involved. Using hand tools, try to identify the material allowing the flow. A qualified engineer should inspect the condition and recommend further actions. <p>ENGINEER REQUIRED</p>

Figure 5.5
Inspection Guidelines - Concrete Upstream Slope

Large Increase in Flow or Sediment in Drain Outfall

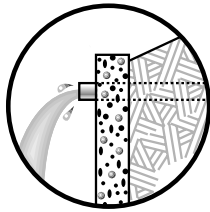

Figure 5.5a

Cracked Deteriorated Concrete Face

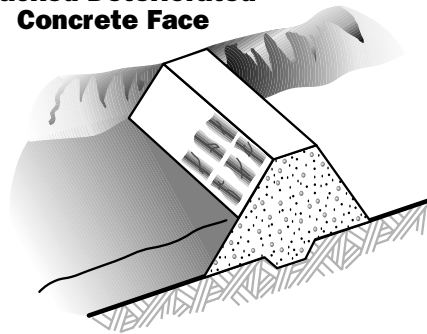

Figure 5.5b

Cracks Due to Drying

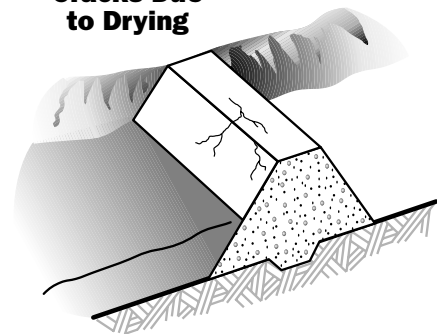

Figure 5.5c

Problem	Probable Cause and Possible Consequences	Recommended Actions
<p>Large Increase in Flow or Sediment in Drain Outfall (Figure 5.5a)</p>	<p>Shortened seepage path or increased storage levels.</p> <ol style="list-style-type: none"> Higher-velocity flows can cause erosion of drain, then embankment materials. Can lead to piping failure. 	<ol style="list-style-type: none"> Accurately measure outflow quantity and determine amount of increase over previous flow. Collect jar samples to compare turbidity. If either quantity or turbidity has increased by 25%, a qualified engineer should evaluate the condition and recommend further actions. <p>ENGINEER REQUIRED</p>
<p>Cracked Deteriorated Concrete Face (Figure 5.5b)</p>	<p>Concrete deteriorated from weathering. Joint filler deteriorated or displaced.</p> <p>Soil is eroded behind the face and caverns can be formed. Unsupported sections of concrete crack. Ice action may displace concrete.</p>	<ol style="list-style-type: none"> Determine cause. Either patch with grout or contact engineer for permanent repair method. If damage is extensive, a qualified engineer should inspect the condition and recommend further actions. <p>ENGINEER REQUIRED</p>
<p>Cracks Due to Drying (Figure 5.5c)</p>	<p>Soil loses its moisture and shrinks, causing cracks. <i>Note:</i> Usually limited to crest and downstream slope.</p> <p>Heavy rains can fill cracks and cause small parts of embankment to move along internal slip surface.</p>	<ol style="list-style-type: none"> Monitor cracks for increases in width, depth, or length. A qualified engineer should inspect condition and recommend further actions. <p>ENGINEER REQUIRED</p>

Figure 5.6
Inspection Guidelines - Spillways

Excessive Vegetation or Debris in Channel

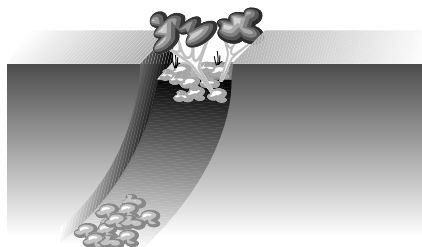

Figure 5.6a

Erosion Channels

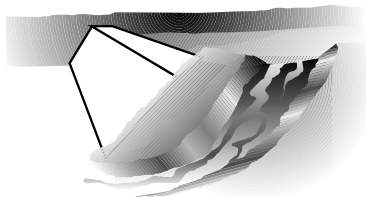

Figure 5.6b

Excessive Erosion in Earth-Slide Causes Concentrated Flows

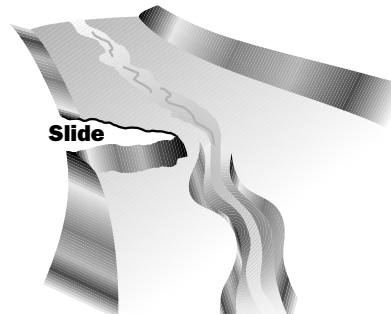

Figure 5.6c

Problem	Probable Cause and Possible Consequences	Recommended Actions
<p>Excessive Vegetation or Debris in Channel <i>(Figure 5.6a)</i></p>	<p>Accumulation of slide materials, dead trees, excessive vegetative growth, etc., in spillway channel.</p> <p>Reduced discharge capacity; overflow of spillway, overcropping of dam. Prolonged overtopping can cause failure of the dam.</p>	<p>Clean out debris periodically; control vegetative growth in spillway channel. Install log boom in front of spillway entrance to intercept debris.</p>
<p>Erosion Channels <i>(Figure 5.6b)</i></p>	<p>Surface runoff from intense rainstorms or flow from spillway carries surface material down the slope, resulting in continuous troughs. Livestock traffic creates gullies where flow concentrates varies.</p> <p>Unabated erosion can lead to slides, slumps or slips which can result in reduced spillway capacity. Inadequate spillway capacity can lead to embankment overtopping and result in dam failure.</p>	<p>Photograph condition. Repair damaged areas by replacing eroded material with compacted fill. Protect areas against future erosion by installing suitable rock riprap. Re-vegetate area if appropriate. Bring condition to the attention of the engineer during next inspection.</p>
<p>Excessive Erosion in Earth-Slide Causes Concentrated Flows <i>(Figure 5.6c)</i></p>	<p>Discharge velocity too high; bottom and slope material loose or deteriorated; channel and bank slopes too steep; bare soil unprotected; poor construction protective surface failed.</p> <p>Disturbed flow pattern; loss of material, increased sediment load downstream, collapse of banks; failure of spillway; can lead to rapid evacuation of the reservoir through the severely eroded spillway.</p>	<p>Minimize flow velocity by proper design. Use sound material. Keep channel and bank slopes mild. Encourage growth of grass on soil surface. Construct smooth and well- compacted surfaces. Protect surface with riprap, asphalt or concrete. Repair eroded portion using sound construction practices.</p>

**Figure 5.6 (cont.)
Inspection Guidelines - Spillways**

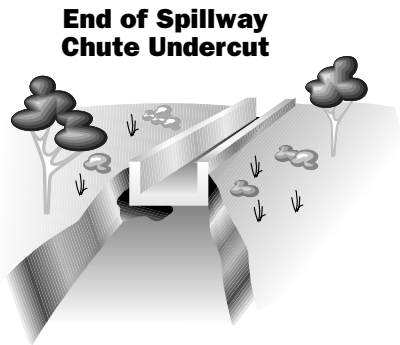

Figure 5.6d

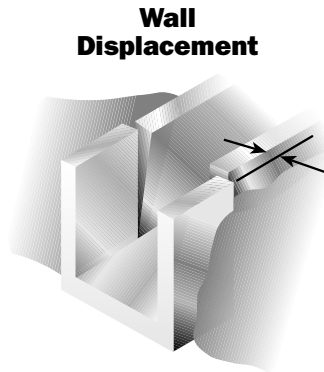

Figure 5.6e

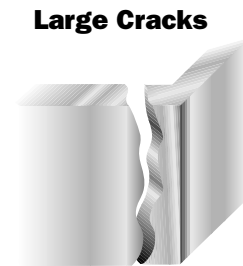

Figure 5.6f

Problem	Probable Cause and Possible Consequences	Recommended Actions
<p>End of Spillway Chute Undercut <i>(Figure 5.6d)</i></p>	<p>Poor configuration of stilling basin area. Highly erodible materials. Absence of cut-off wall at end of chute.</p> <p>Structural damage to spillway structure; collapse of slab and wall lead to costly repair.</p>	<p>Dewater affected area; clean out eroded area and properly backfill. Improve stream channel below chute; provide properly sized riprap in stilling basin area. Install cutoff wall.</p>
<p>Wall Displacement <i>(Figure 5.6e)</i></p>	<p>Poor workmanship; uneven settlement of foundation; excessive earth and water pressure; insufficient steel bar reinforcement of concrete.</p> <p>Minor displacement will create eddies and turbulence in the flow, causing erosion of the soil behind the wall. Major displacement will cause severe cracks and eventual failure of the structure.</p>	<p>Reconstruction should be done according to sound engineering practices. Foundation should be carefully prepared. Adequate weep holes should be installed to relieve water pressure behind wall. Use enough reinforcement in the concrete. Anchor walls to prevent further displacement. Install struts between spillway walls. Clean out and backflush drains to assure proper operations. Consult an engineer before actions are taken.</p> <p>ENGINEER REQUIRED</p>
<p>Large Cracks <i>(Figure 5.6f)</i></p>	<p>Construction defect; local concentrated stress; local material deterioration; foundation failure, excessive backfill pressure.</p> <p>Disturbance in flow patterns; erosion of foundation and backfill; eventual collapse of structure.</p>	<p>Large cracks without large displacement should be repaired by patching.</p> <p>Surrounding areas should be cleaned or cut out before patching material is applied. (See Chapter 7.) Installation of weep holes or other actions may be needed.</p>

**Figure 5.6 (cont.)
Inspection Guidelines - Spillways**

Open or Displaced Joints

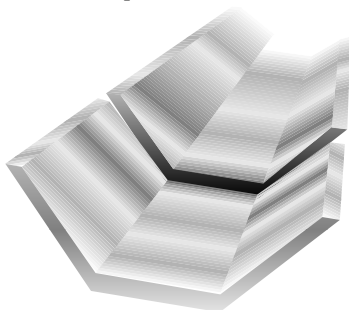

Figure 5.6g

Breakdown and Loss of Riprap

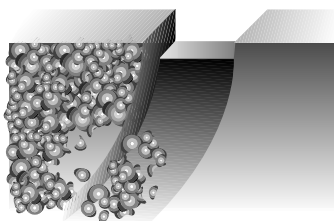

Figure 5.6h

**Material Deterioration—
Spalling and Disintegration
of Riprap, Concrete, Etc.**

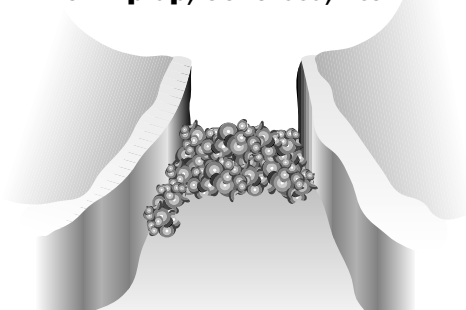

Figure 5.6i

Problem	Probable Cause and Possible Consequences	Recommended Actions
<p>Open or Displaced Joints <i>(Figure 5.6g)</i></p>	<p>Excessive and uneven settlement of foundation; sliding of concrete slab; construction joint too wide and left unsealed. Sealant deteriorated and washed away.</p> <p>Erosion of foundation material may weaken support and cause further cracks; pressure induced by water flowing over displaced joints may wash away wall or slab, or cause extensive undermining.</p>	<p>Construction joint should be no wider than 1/2". All joints should be sealed with asphalt or other flexible materials. Water stops should be used where feasible. Clean the joint, replace eroded materials, and seal the joint. Foundations should be properly drained and prepared. Under-side of chute slabs should have ribs of enough depth to prevent sliding. Avoid steep chute slope.</p> <p>ENGINEER REQUIRED</p>
<p>Breakdown and Loss of Riprap <i>(Figure 5.6h)</i></p>	<p>Slope too steep; material poorly graded; failure of subgrade; flow velocity too high; improper placement of material; bedding material or foundation washed away.</p> <p>Erosion of channel bottom and banks; failure of spillway.</p>	<p>Design a stable slope for channel bottom and banks. Riprap material should be well-graded (the material should contain small, medium and large particles). Subgrade should be properly prepared before placement of riprap. Install filter fabric if necessary. Control flow velocity in the spillway by proper design. Riprap should be placed according to specification.</p> <p>ENGINEER REQUIRED</p>
<p>Material Deterioration— Spalling and Disintegration of Riprap, Concrete, Etc. <i>(Figure 5.6i)</i></p>	<p>Use of unsound or defective materials; structures subject to freeze-thaw cycles; improper maintenance practices; harmful chemicals. Structure life will be shortened; premature failure.</p>	<p>Avoid using shale or sandstone for riprap. Add air-entraining agent when mixing concrete. Use only clean, good-quality aggregates in the concrete. Steel bars should have at least 1" of concrete cover. Concrete should be kept damp and protected from freezing during curing.</p>

**Figure 5.6 (cont.)
Inspection Guidelines - Spillways**

Poor Surface Drainage

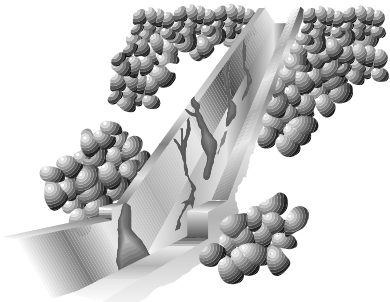

Figure 5.6j

Concrete Erosion, Abrasion, and Fracturing

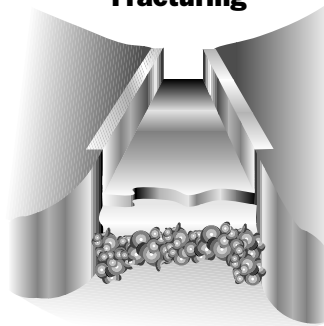

Figure 5.6k

Leakage in or Around Spillway

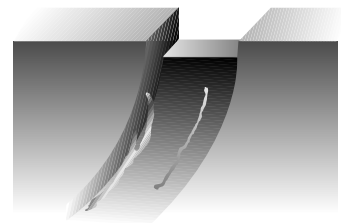

Figure 5.6l

Problem	Probable Cause and Possible Consequences	Recommended Actions
<p>Poor Surface Drainage <i>(Figure 5.6j)</i></p>	<p>No weep holes; no drainage facility; plugged drains.</p> <p>Wet foundation has lower supporting capacity; uplift pressure resulting from seepage water may damage spillway chute; accumulation of water may also increase total pressure on spillway walls and cause damage.</p>	<p>Install weep holes on spillway walls. Inner end of hole should be surrounded and packed with graded filtering material. Install drain system under spillway near downstream end. Clean out existing weep holes. Backflush and rehabilitate drain system under the supervision of an engineer.</p> <p>ENGINEER REQUIRED</p>
<p>Concrete Erosion, Abrasion, and Fracturing <i>(Figure 5.6k)</i></p>	<p>Flow velocity too high (usually occurs at lower end of chute in high dams); rolling of gravel and rocks down the chutes; cavity behind or below concrete slab.</p> <p>Pockmarks and spalling of concrete surface may progressively worsen; small hole may cause undermining of foundation, leading to failure of structure.</p>	<p>Remove rocks and gravels from spillway chute before flood season. Raise water level in stilling basin. Use good-quality concrete. Assure concrete surface is smooth.</p> <p>ENGINEER REQUIRED</p>
<p>Leakage in or Around Spillway <i>(Figure 5.6l)</i></p>	<ol style="list-style-type: none"> 1. Cracks and joints in geologic formation at spillway are permitting seepage. 2. Gravel or sand layers at spillway are permitting seepage. <ol style="list-style-type: none"> 1. Could lead to excessive loss of stored water. 2. Could lead to a progressive failure if velocities are high enough to cause erosion of natural materials. 	<ol style="list-style-type: none"> 1. Examine exit area to see if type of material can explain leakage. 2. Measure flow quantity and check for erosion of natural materials. 3. If flow rate or amount of eroded materials increases rapidly, reservoir level should be lowered until flow stabilizes or stops. 4. A qualified engineer should inspect the condition and recommend further actions. <p>ENGINEER REQUIRED</p>

**Figure 5.6 (cont.)
Inspection Guidelines - Spillways**

Too Much Leakage From Spillway Under Drains

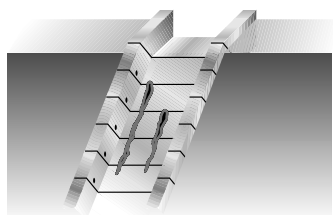

Figure 5.6m

Seepage From a Construction Joint or Crack in Concrete Structure

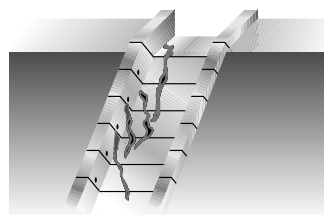
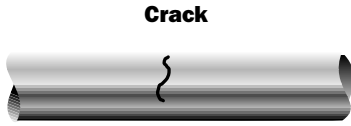

Figure 5.6n

Problem	Probable Cause and Possible Consequences	Recommended Actions
<p>Too Much Leakage From Spillway Under Drains <i>(Figure 5.6m)</i></p>	<p>Drain or cutoff may have failed.</p> <ol style="list-style-type: none"> 1. Excessive flows under the spillway could lead to erosion of foundation material and collapse of parts of the spillway. 2. Uncontrolled flows could lead to loss of stored water. 	<ol style="list-style-type: none"> 1. Examine exit area to see if type of material can explain leakage. 2. Measure flow and check for erosion of natural materials. 3. If flow rate or amount of eroded materials increases rapidly, reservoir level should be lowered until flow stabilizes or stops. 4. A qualified engineer should inspect the condition and recommend further actions. <p>ENGINEER REQUIRED</p>
<p>Seepage From a Construction Joint or Crack in Concrete Structure <i>(Figure 5.6n)</i></p>	<p>Water is collecting behind structure because of insufficient drainage or clogged weep holes.</p> <ol style="list-style-type: none"> 1. Can cause walls to tip in and over. Flows through concrete can lead to rapid deterioration from weathering. 2. If spillway is located within embankment, rapid erosion can lead to failure of the dam. 	<ol style="list-style-type: none"> 1. Check area behind wall for puddling of surface water. 2. Check and clean as needed; drain outfalls, flush lines and weep holes. 3. If condition persists, a qualified engineer should inspect the condition and recommend further actions. <p>ENGINEER REQUIRED</p>

Figure 5.7
Inspection Guidelines - Inlets, Outlets, and Drains

Outlet Pipe Damage



Crack

Figure 5.7a-1

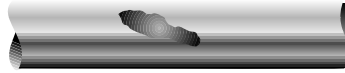

Hole

Figure 5.7a-2

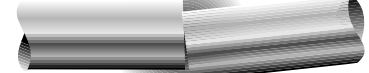

Joint Offset

Figure 5.7a-3

Problem	Probable Cause and Possible Consequences	Recommended Actions
<p>Outlet Pipe Damage: Crack (Figure 5.7a-1)</p>	<p>Settlement; impact. Excessive seepage, possible internal erosion.</p>	<p>Check for evidence of water either entering or exiting pipe at crack, hole, etc.</p>
<p>Outlet Pipe Damage: Hole (Figure 5.7a-2)</p>	<p>Rust (steel pipe); erosion (concrete pipe); cavitation. Excessive seepage, possible internal erosion.</p>	<p>Tap pipe in vicinity of damaged area, listening for hollow sound which indicates a void has formed along the outside of the conduit.</p>
<p>Outlet Pipe Damage: Joint Offset (Figure 5.7a-3)</p>	<p>Settlement or poor construction practice. Provides passageway for water to exit or enter pipe, resulting in erosion of internal materials of the dam.</p>	<p>If a progressive failure is suspected, request engineering advice.</p>

**Figure 5.7 (cont.)
Inspection Guidelines - Inlets, Outlets, and Drains**

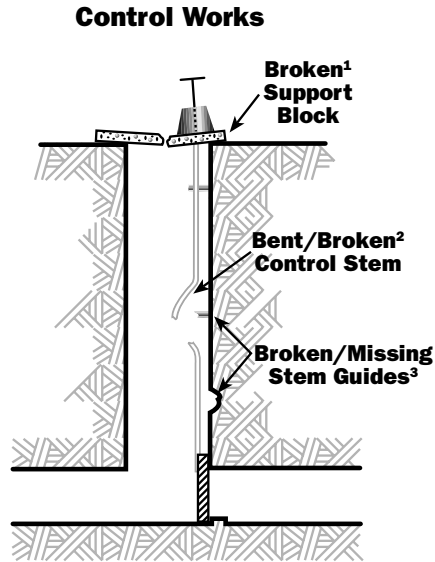
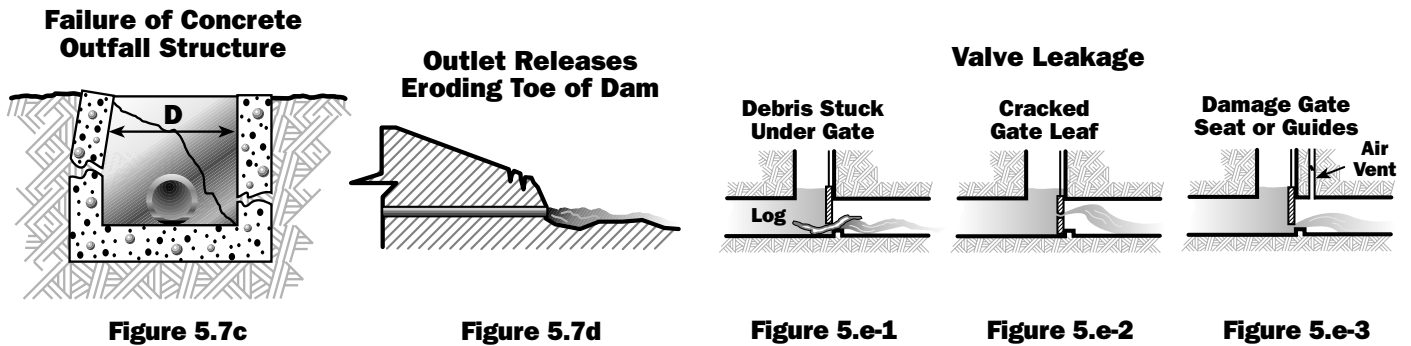

Figure 5.7b

Problem	Probable Cause and Possible Consequences	Recommended Actions
<p>Damage to Control Works <i>(Figure 5.7b)</i></p>	<ol style="list-style-type: none"> 1. BROKEN SUPPORT BLOCK Concrete deterioration. Excessive force exerted on control stem by trying to open gate when it was jammed. Causes control support block to tilt; control stem may bind. Control head works may settle. Gate may not open all the way. Support block may fail completely, leaving outlet inoperable. 2. BENT/BROKEN CONTROL STEM Rust. Excess force used to open or close gate. Inadequate or broken stem guides. Outlet is inoperable. 3. BROKEN/MISSING STEM GUIDES Rust. Inadequate lubrication. Excess force used to open or close gate when jammed. Loss of support for control stem. Stem may buckle and break under normal use (as in this example). 	<p>Any of these conditions can mean the control is either inoperable or, at best, partly operable. Use of the system should be minimized or discontinued. If the outlet system has a second control valve, consider using it to regulate releases until repairs can be made. Engineering help is recommended.</p>

**Figure 5.7 (cont.)
Inspection Guidelines - Inlets, Outlets, and Drains**



Problem	Probable Cause and Possible Consequences	Recommended Actions
<p>Failure of Concrete Outfall Structure (Figure 5.7c)</p>	<p>Excessive side pressures on nonreinforced concrete structure. Poor concrete quality.</p> <p>Loss of outfall structure exposes embankment to erosion by outlet releases.</p>	<p>1. Check for progressive failure by monitoring typical dimension, such as “D” shown in figure.</p> <p>2. Repair by patching cracks and supplying drainage around concrete structure. Outfall structure may need total replacement.</p>
<p>Outlet Releases Eroding Toe of Dam (Figure 5.7d)</p>	<p>Outlet pipe too short. Lack of energy-dissipating pool or structure at downstream end of conduit.</p> <p>Erosion of toe oversteepens downstream slope, causing progressive sloughing.</p>	<p>1. Extend pipe beyond toe (use pipe of same size and material, and form watertight connection to existing conduit).</p> <p>2. Protect embankment with riprap over suitable bedding.</p>
<p>Valve Leakage: Debris Stuck Under Gate (Figure 5.7e-1)</p>	<p>Trashrack missing or damaged.</p> <p>Gate will not close. Gate or stem may be damaged in effort to close gate.</p>	<p>Raise and lower gate slowly until debris is loosened and floats past valve. When reservoir is lowered, repair or replace trashrack.</p>
<p>Valve Leakage: Cracked Gate Leaf (Figure 5.7e-2)</p>	<p>Ice action, rust, affect vibration, or stress resulting from forcing gate closed when it is jammed.</p> <p>Gate-leaf main fail completely, evacuating reservoir.</p>	<p>Use valve only in fully open or closed position. Minimize use of valve until leaf can be repaired or replaced.</p>
<p>Valve Leakage: Damaged Gate Seat or Guides (Figure 5.7e-3)</p>	<p>Rust, erosion, cavitation, vibration or wear.</p> <p>Leakage and loss of support for gate leaf. Gate may bind in guides and become inoperable.</p>	<p>Minimize use of valve until guides or seats can be repaired. If cavitation is the cause, check to see if air-vent pipe exists, and is unobstructed.</p>

**Figure 5.7 (cont.)
Inspection Guidelines - Inlets, Outlets, and Drains**

Seepage Water Exiting From a Point Adjacent to the Outlet

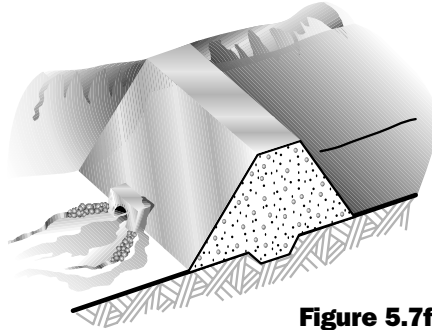

Figure 5.7f

Problem	Probable Cause and Possible Consequences	Recommended Actions
<p>Seepage Water Exiting From a Point Adjacent to the Outlet <i>(Figure 5.7f)</i></p>	<ol style="list-style-type: none"> 1. A break in the outlet pipe. 2. A path for flow has developed along the outside of the outlet pipe. <p>Continued flows can lead to erosion of the embankment materials and failure of the dam.</p>	<ol style="list-style-type: none"> 1. Thoroughly investigate the area by probing and/or shoveling to try to determine cause. 2. Determine if leakage water is carrying soil particles. 3. Determine quantity of flow. 4. If flow increases or is carrying embankment materials, reservoir level should be lowered until leakage stops. 5. A qualified engineer should inspect the condition and recommend further actions. <p>ENGINEER REQUIRED</p>

Chapter 6: Instrumentation and Monitoring Guidelines

6.0 General

Widespread attention is now being given to the installation of more expensive instrumentation for study of the behavior of dams and reservoirs and forecasting of any adverse trends.

—Jansen (1980: 25)

The means and methods available to monitor phenomena that can lead to dam failure include a wide spectrum of instruments and procedures, ranging from very simple to very complex. Any program of dam safety instrumentation must be properly designed and consistent with other project components, must be based on prevailing geotechnical conditions at the dam, and must consider the hydrologic and hydraulic factors present both before and after the project is in operation. Every instrument should have a specific purpose and expected design response.

Instruments designed for monitoring potential deficiencies at existing dams must take into account the threat to life and property that the dam presents. Thus, the extent and nature of the instrumentation depends not only on the complexity of the dam and the size of the reservoir, but also on the potential for loss of life and property downstream.

An instrumentation program should involve instruments and evaluation methods that are as simple and straightforward as the project will allow. Beyond that, the dam owner should make a

definite commitment to an ongoing monitoring program or the installation of instruments probably will be wasted.

This chapter discusses deficiencies in dams that may be discovered and the types of instruments that may be used to monitor those deficiencies. Increased knowledge of these deficiencies acquired through a monitoring program is useful in determining both the cause of the deficiencies and the necessary remedies. Continued monitoring is important to determine that the remedy remains effective.

Involvement of qualified personnel in the design, installation, monitoring, and evaluation of an instrumentation system is of prime importance to the success of the program.

6.1 Reasons for Instrumentation

Instrumentation and proper monitoring and evaluation are extremely valuable in determining the performance of a dam. Specific reasons for instrumentation include:

- **Warning of a Problem**—Often, instruments can detect unusual changes, such as fluctuations in water pressure within the dam, that are not visible. In other cases, gradual progressive changes in seepage flow, which would go unnoticed visually, can be monitored regularly. This monitoring can warn of the development of a serious seepage problem.
- **Analyzing and Defining a Problem**—Instrumentation data are frequently

used to obtain engineering information necessary for analyzing and defining the extent of a problem. For example, downstream movement of a dam because of high reservoir-water pressure must be analyzed to determine if the movement is uniformly distributed along the dam; whether the movement is in the dam, the foundation, or both; and whether the movement is constant, increasing, or decreasing. Such information can then be used to design corrective measures.

- **Proving Behavior Is as Expected**—Instruments installed at a dam may infrequently (or even never) show any anomaly or problem. However, even that information is valuable because it shows that the dam is performing as designed, offering peace of mind to you, the owner. Also, although a problem may appear to be extant or imminent, instrument readings might show that the deficiency (for example, increased seepage) is normal (merely a result of higher than normal reservoir level) and was foreseen in the dam's design.
- **Evaluating Remedial Action Performance**—Many dams, particularly older ones, are modified to allow for increased capacity or to correct a deficiency. Instrument readings before and after the change allow analysis and evaluation of the performance of the modification.

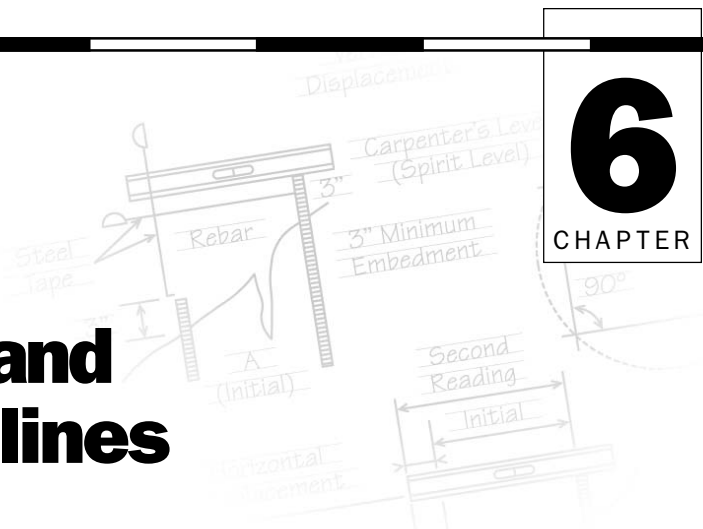

6.2 Instrument Types and Usage

A wide variety of devices and procedures are used to monitor dams. The features of dams and dam sites most often monitored by instruments include: [throughout chapter: lowercased bullet items]

- movements (horizontal, vertical, rotational and lateral)
- pore pressure and uplift pressures
- water level and flow
- seepage flow
- water quality
- temperature
- crack and joint size
- seismic activity
- weather and precipitation
- stress and strain

A thorough treatment of instrument types and their usage is presented in Dunicliff 1993. Both the U.S. Bureau of Reclamation and the U.S. Army Corps of Engineers publish guides specific to the instrumentation and monitoring of dams. The Association of State Dam Safety Officials <www.damsafety.org> and the U.S. Society of Dams <www.USSDams.org> offer technical conferences, reports, and papers related to instrumentation and dam-safety monitoring.

6.2.1 Observations

As discussed in Chapter 5, observations by you, the dam owner, or your representative may be the most important and effective means of monitoring the performance of a dam. An inspector, upon each visit to the dam site, should inspect it visually—at a minimum, walking along the dam alignment and looking for any signs of distress or unusual conditions.

6.2.2 Movements

Movements occur in every dam. They are caused by stresses induced by reservoir

water pressure, unstable slopes (low shearing strength), low foundation shearing strength, settlement (compressibility of foundation and dam materials), thrust due to arching, expansion resulting from temperature change, and heave resulting from hydrostatic uplift pressures. They can be categorized by direction:

- **Horizontal or translational movement** commonly occurs in an upstream-downstream direction in both embankment and concrete dams. It involves the movement of an entire dam mass relative to its abutments or foundation. In an embankment dam, instruments

commonly used for monitoring such movement include:

- extensometers, including multi-point extensometers
- inclinometers
- embankment measuring points
- shear strips
- structural measuring points
- time-domain reflectometry (TDR)

Installation of simple measuring points is illustrated in Figure 6.1, a and b, a simple crack monitoring system is shown in Figure 6.2, and inclinometer systems and plots are shown in Figures 6.3a–c.

Figure 6.1a
Installation of Permanent Points

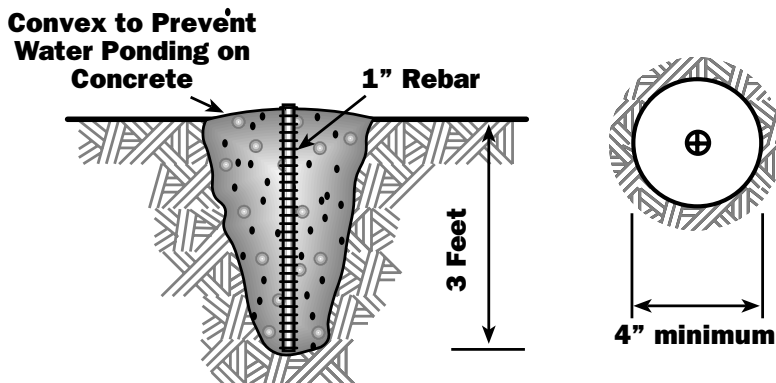
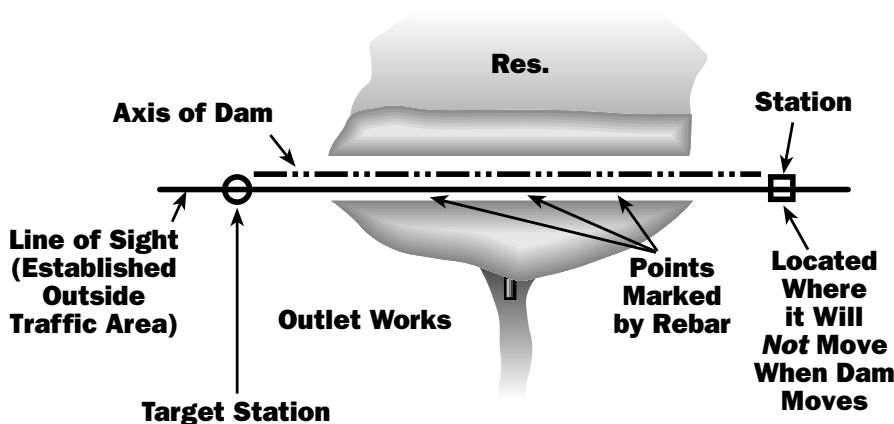
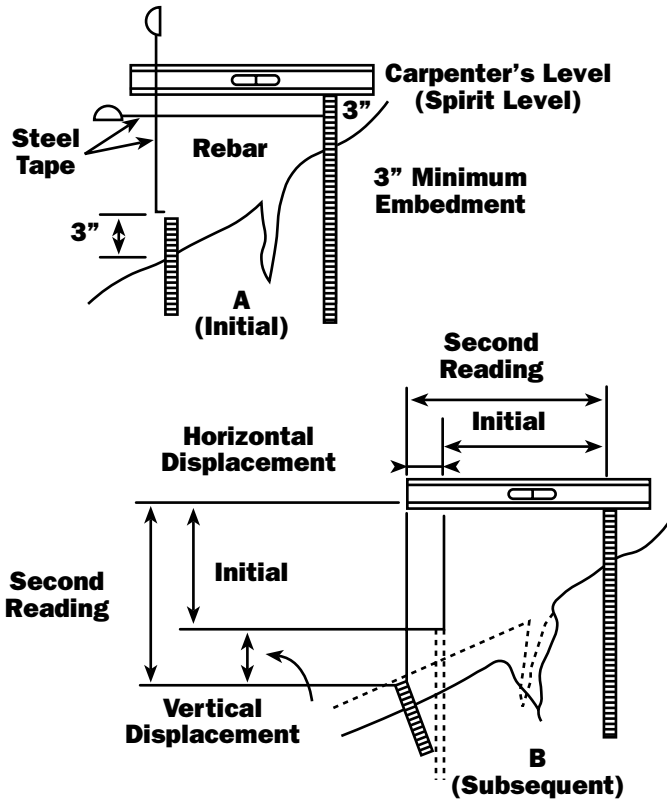

Figure 6.1b
Plan of Alignment System



**Figure 6.2
Monitoring Cracks on Embankment**



**Figure 6.3a
Inclinometer—
Detail at Surface**

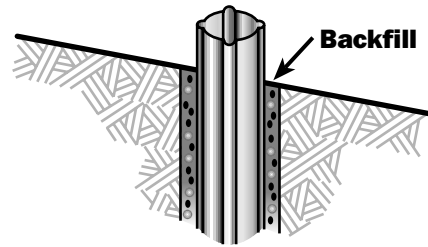

**Figure 6.3b
Plot of Inclinometer Readings**

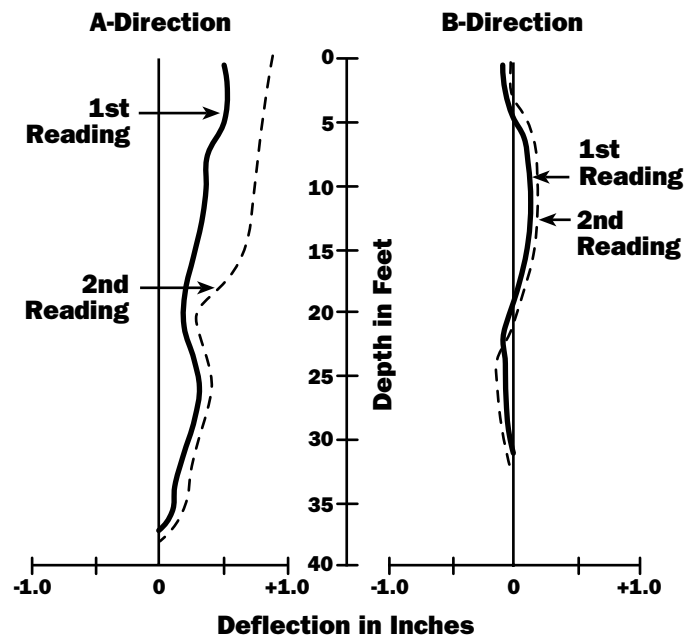

For a concrete dam or concrete spillway, instruments for monitoring horizontal movements may include:

- crack measuring devices
- extensometers, including multi-point extensometers
- inclinometers
- structural measuring points
- tape gauges
- strain meters
- plumb lines
- foundation-deformation gauges
- tilt meters
- 2D or 3D joint-movement indicators
- electro-level beams
- a GPS monitoring system

Examples of monitoring of concrete structure movements are shown in Figures 6.4a-d.

- **Vertical movement** is commonly a result of consolidation of embankment or foundation materials resulting in settlement of the dam. Another cause is heave (particularly at the toe of a dam) caused by hydrostatic uplift pressures.

**Figure 6.3c
Inclinometer and Casing**

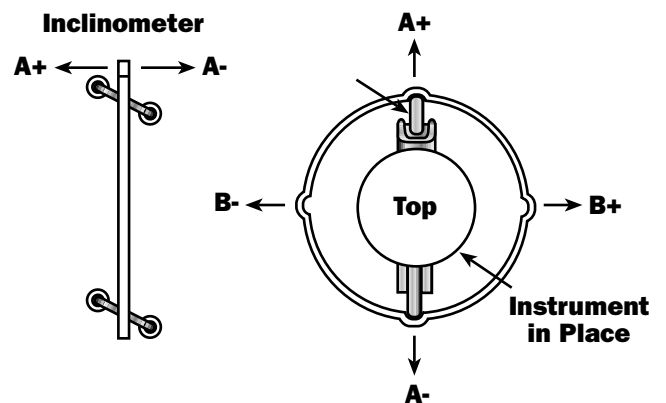
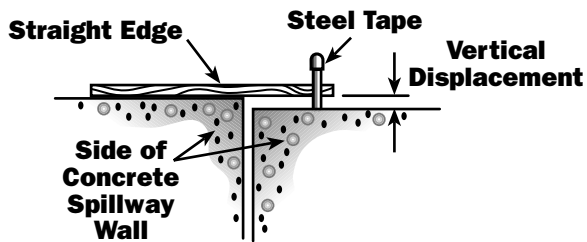
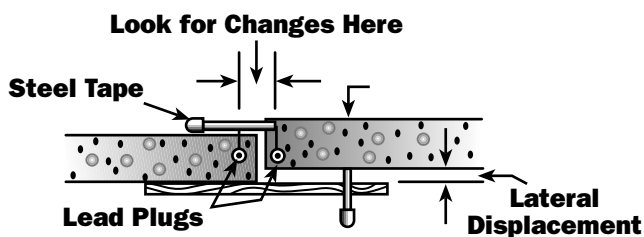

Figure 6.4
Measuring Displacements



(A) Straight Edge and Tape



(B) Straight Edge and Tape Plus Reference Points

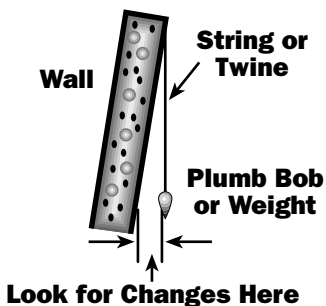

(C) Plumb Bob

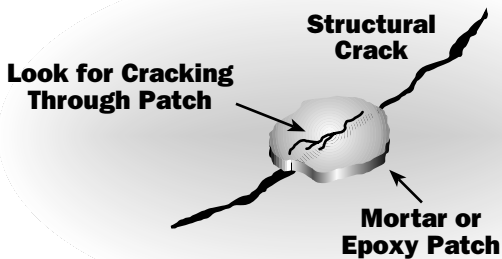

(D) Mortar Marker

In an embankment dam, vertical movements may be monitored by:

- settlement plates and sensors
- extensometers
- embankment survey monuments
- structural measuring points
- inclinometer casing measurements

In a concrete dam or concrete spillway, vertical movement monitoring devices may include:

- settlement sensors
- extensometers
- a GPS monitoring system
- structural measuring points
- foundation-deformation gauges

■ **Rotational movement** is commonly a result of high reservoir water pressure in combination with low shearing strength in an embankment or foundation; it may occur in either component of a dam. This kind of movement may be measured in either embankment or concrete dams by instruments such as:

- extensometers
- inclinometers
- tilt meters
- surface measurement points
- crack-measurement devices
- electro-level beam sensors
- foundation-deformation gauges
- plumb lines (concrete only)

■ **Lateral movement** (parallel with the crest of a dam) is common in concrete arch and gravity dams. The structure of an arch dam causes reservoir water pressure to be translated into a horizontal thrust against each abutment. Gravity dams also exhibit some lateral movement because of expansion and contraction due to temperature changes. These movements may be detected by:

- structural measurement points
- tilt meters
- extensometers
- crack-measurement devices
- plumb lines
- strain meters
- stress meters
- inclinometers
- joint meters
- load cells

6.2.3 Pore Pressure and Uplift Pressure

As discussed in Chapter 2, a certain amount of water seeps through, under, and around the ends of all dams. The water moves through pores in the soil, rock, or concrete as well as through cracks, joints, etc. The pressure of the water as it moves acts uniformly in all planes and is termed *pore pressure*. The upward force (called *uplift pressure*) has the effect of reducing the effective weight of the downstream portion of a dam and can materially reduce dam stability. Pore pressure in an embankment dam, a dam foundation, or an abutment reduces that component's shear strength. In addition, excess water, if not effectively channeled by drains or filters, can result in progressive internal erosion (piping) and failure. Pore pressures can be monitored with the following equipment.

- piezometers
- electrical
- open well
- pneumatic
- hydraulic
- porous tube
- slotted pipe
- pressure meters and gauges
- load cells

Pore-pressure measurements and monitoring can supply critical information regarding the overall stability of an embankment dam following a major earthquake.

Simple piezometers may resemble the illustration in Figure 6.5; a basic observation well is shown in Figure 6.6.

6.2.4 Water Level and Flow

For most dams, it is important to monitor the water level in the reservoir and the downstream pool regularly to determine the quantity of water in the reservoir and its level relative to the regular

Figure 6.5
Porous Stone Piezometer

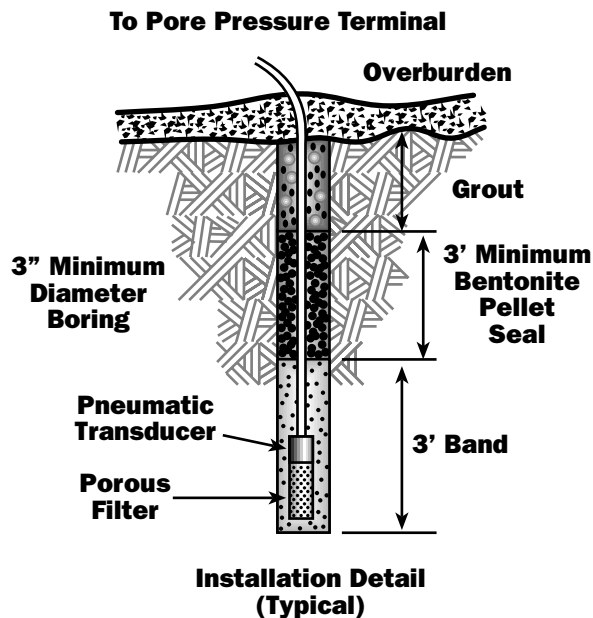
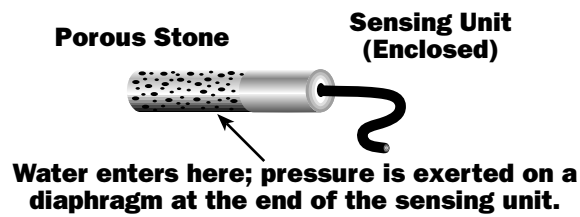
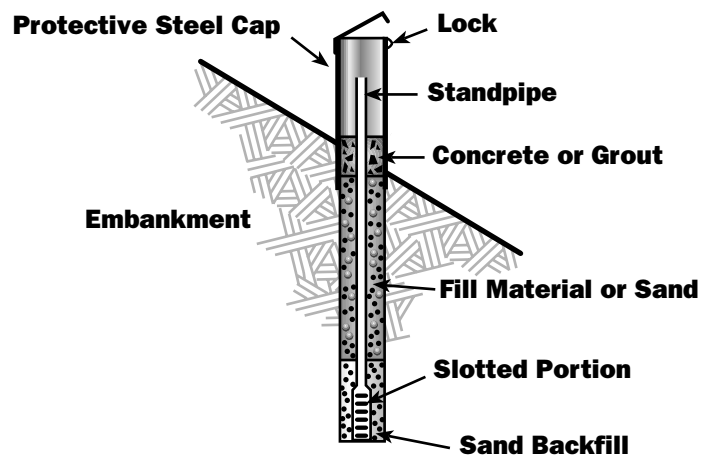

Figure 6.6
Installation of Typical Observation Well



outlet works and the emergency spillway. The water level is also used to compute water pressure and pore pressure; the volume of seepage is usually directly related to the reservoir level. It is also important to establish the normal or typical flow through the outlet works for legal purposes.

Water levels may be measured by simple elevation gauges—either staff gauges or numbers painted on permanent, fixed structures in the reservoir—or by complex devices that sense water levels. Flows are often computed from a knowledge of the dimensions of the outlet works and the depth of flow in the outlet channel or pipe.

6.2.5 Seepage Flow

Seepage must be monitored on a regular basis to determine if it is increasing, decreasing, or remaining constant as the reservoir level fluctuates. A flow rate changing relative to a reservoir water level can be an indication of a clogged drain, piping or internal cracking of the embankment. Seepage may be measured using the following devices and methods:

- Weirs (any shape such as V-notch, rectangular, trapezoidal, etc.)

- Flumes (such as a Parshall flume)
- Pipe methods
- Timed-bucket methods
- Flow meters

Examples of weirs, flumes, and bucket measuring installations are illustrated in Figures 6.7a–c, 6.8, and 6.9.

6.2.6 Water Quality

Seepage comes into contact with various minerals in the soil and rock in and around the dam, which can cause two problems: the chemical dissolution of a natural rock such as limestone and the internal erosion of soil.

Dissolution of minerals can often be detected by comparing chemical analyses

of reservoir water and seepage water. Such tests are site specific; for example, in a limestone area, one would look for calcium and carbonates; in a gypsum area, calcium and sulfates. Other tests, such as pH, can also sometimes provide useful information on chemical dissolution.

Internal erosion can be detected by comparing turbidity of reservoir water with that of seepage water. A large increase in turbidity indicates erosion.

6.2.7 Temperature

The internal temperature of concrete dams is commonly measured both during and after construction. During construction, the heat of hydration of freshly placed concrete can create high stresses which can result in cracking later. After construction is completed and a dam is in operation, very significant temperature differentials are not uncommon, depending on the season. For example, during winter, the upstream face of a dam remains relatively warm because of reservoir-water temperature, while the downstream face of the dam is reduced to a cold ambient air temperature. The reverse is true in summer.

Temperature measurements are important both to determine causes of movement due to expansion

Figure 6.7a
Standard Weir Installation

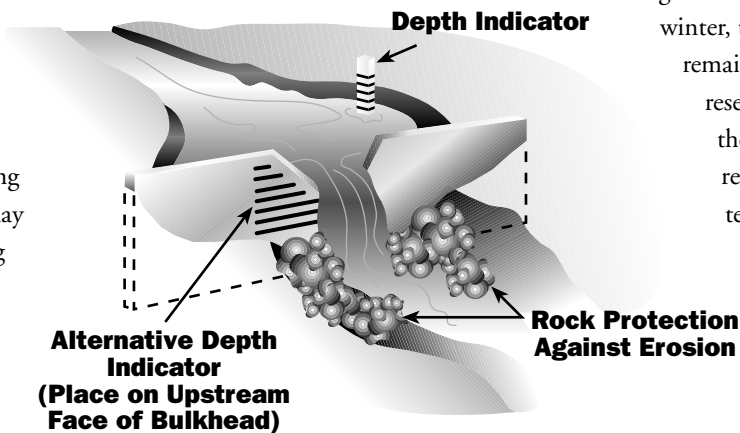

Figure 6.7b
Standard Weirs: 90° V-Notch Weir

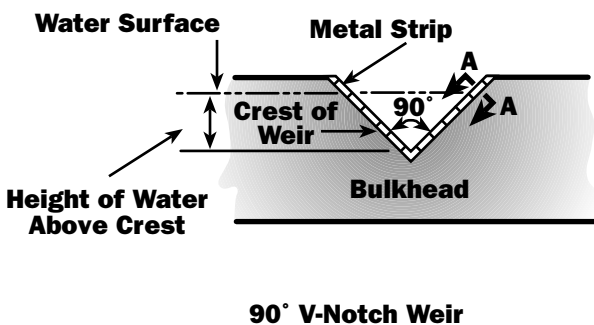

Figure 6.7c
Standard Weirs: Rectangular Weir

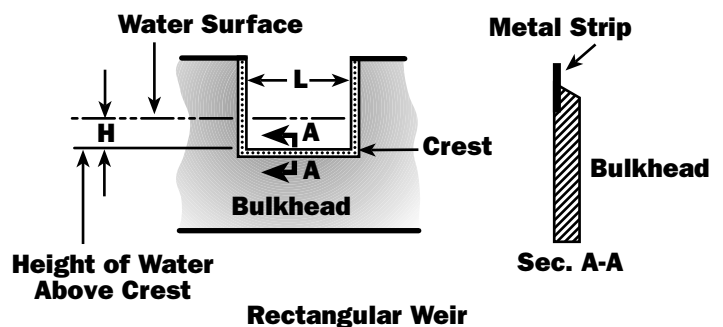

Figure 6.8
Parshall Flume

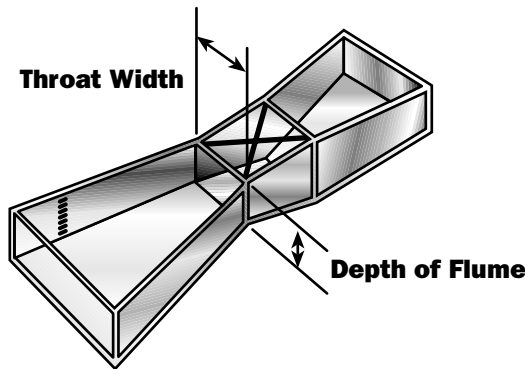
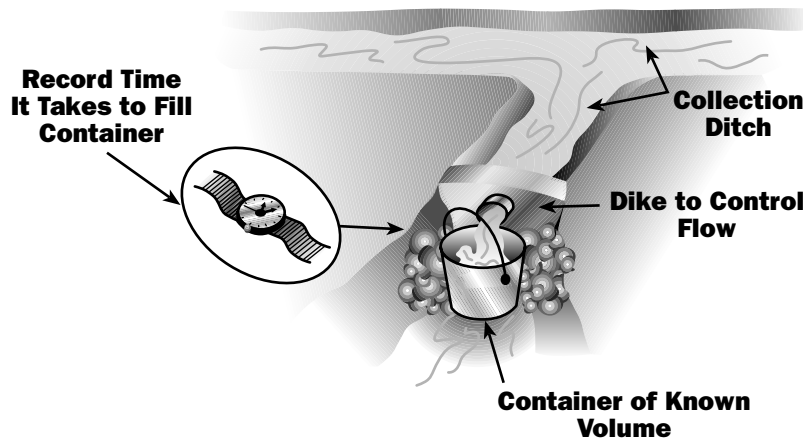

Figure 6.9
Bucket-and-Stopwatch Method



sion or contraction and to compute actual movement. Temperature may be measured using any of several different kinds of embedded thermometers or by simultaneous temperature readings on devices such as stress and strain meters, which allow for indirect measurement of the temperature of the mass.

6.2.8 Crack and Joint Size

Knowing the locations and widths of cracks and joints in concrete dams and in concrete spillways and other concrete appurtenances of embankment dams is important because of the potential for seepage through those openings. It is even more important to know if the width of

such openings is increasing or decreasing. Various measuring devices are available for cracks and joints, most allowing very accurate measurement. Some use simple tape or dial gauges; others, complex electronics.

6.2.9 Seismic Activity

Seismic measuring devices record the intensity and duration of large-scale earth movements such as earthquakes. Many federal and state dams use these instruments because they are part of the U.S. Geological Survey's network of seismic recording stations. It may or may not be necessary for a private dam to contain seismic devices depending upon the area's seismic risk. Seismic instruments can also

be used to monitor any blasting conducted near a dam site.

6.2.10 Weather

Monitoring the weather at a dam site can provide valuable information about both day-to-day performance and developing problems. A rain gauge, thermometer, and wind gauge can be easily purchased, installed, maintained, and monitored at a dam site.

6.2.11 Stress and Strain

Measurements to determine stress and strain are common in concrete dams and, to a lesser extent, in embankment dams. The monitoring devices previously listed for measuring dam movements, crack and joint size, and temperature are also appropriate for measuring stress and strain. Monitoring for stress and strain permits very early detection of movement.

6.3 Automated Data-Acquisition Systems

Over the last 20 years, there have been significant efforts, primarily led by federal dam-safety organizations, to advance the state of practice in automating dam-safety instrumentation. These projects were initially targeted towards high hazard dams that posed significant potential risk to downstream communities. These two decades have seen many advances in sensor technology, data acquisition equipment, and data management that have made automated data acquisition more reliable, cost-effective, and readily available for broader applications in dam-safety monitoring.

An automated data-acquisition system (or ADAS) can range from a simple data logger temporarily connected to one or more instruments to a permanent system

that automates up to several hundred instruments at a dam. Generally, an ADAS for dam-safety monitoring includes the following key components:

- one or more electronic sensors (for water levels, displacements, etc.)
- a remote data logger (permanent or portable)
- a communication link to the dam for remote access (cell phone, landline, radio, or satellite)

An ADAS usually consists of one or more solar-powered remote monitoring units (RMUs) located on the dam connected to key instruments to be automated. The RMUs communicate via radio, hardwire, or cell phone with a central network monitor—a conventional desktop PC with vendor-supplied interface and communication software to provide access to the on-site RMUs by remote users. Typically, the monitor is located on-site; however, it can be located at a remote location (such as a district or administration building). Instrument readings are stored in memory for either manual or automatic downloading for plotting and tabular reporting.

These systems can send out an alarm via cell phone, pagers, or e-mail if user-

defined instrument thresholds are exceeded. More recently, ADASes now incorporate remote digital still or video cameras.

Since these systems are employed outdoors, it is important to use only data-acquisition equipment that is designed for geotechnical instrumentation and dam-safety monitoring. Pay special attention to lightning protection and grounding, surge protection, and backup power supplies. You would be wise to contact engineering companies and vendors that are experienced in this area if you are considering an ADAS for your dam-monitoring requirements.

A properly designed and installed ADAS can provide cost-effective and reliable instrumentation data acquisition and presentation to assist dam safety personnel in both long-term monitoring and during safety events. These systems provide the ability to adjust the frequency of instrument readings and provide the ability to quickly assess trends from remote locations. When coupled with downstream warning sirens, ADAS can provide early warning to downstream residents during a safety problem.

For more information on ADASes for dam-safety monitoring, refer to U.S. Society of Dams (2002).

6.4 Frequency of Monitoring

The frequency of instrument readings or making observations at a dam depends on several factors including:

- the relative hazard to life and property it represents
- its height or overall size
- the relative quantity of water impounded
- the relative seismic risk at the site
- its age
- the frequency and amount of water-level fluctuation in the reservoir

In general, as each of the above factors increases, the frequency of monitoring should increase. For example, very frequent (even daily) readings should be taken during the first filling of a reservoir, and more frequent readings should be taken when water levels are high and after significant storms and earthquakes. As a rule of thumb, simple visual observations should be made during each visit to the dam and not less than monthly. Daily or weekly readings should be made during the first filling, immediate readings should be taken following a storm or earthquake, and significant seepage, movement, and stress-strain readings should probably be made at least monthly.

Source for information in this chapter: Jim Hummert, URS Corporation. St. Louis

Chapter 7: Maintenance Guidelines

7.0 General

A good maintenance program will protect a dam against deterioration and prolong its life. A poorly maintained dam will deteriorate, and may fail. Nearly all the components of a dam and the materials used for its construction are susceptible to damaging deterioration if not properly maintained. A good maintenance program protects not only you, the owner, but the general public as well. Moreover, the cost of a proper maintenance program is small compared to the costs of major repairs, loss of life and property, and litigation.

Develop a basic maintenance program based primarily on systematic and frequent inspections. Inspections, as noted in Chapter 5, should be performed at least monthly and after major floods or earthquakes. During each inspection, refer to a checklist of items that call for maintenance.

7.1 Maintenance Priorities

Maintenance should never be neglected. The following outline lists, by relative priority, the various problems or conditions that might be encountered in a dam that has deteriorated from lack of maintenance.

7.1.1 Immediate Maintenance

The following conditions are critical and call for immediate attention:

- A dam about to be overtopped or being overtopped.
- A dam about to be breached (by progressive erosion, slope failure, or other circumstances).
- A dam showing signs of piping or internal erosion indicated by increasingly cloudy seepage or other symptoms.
- A spillway being blocked or otherwise rendered inoperable, or having normal discharge restricted.
- Evidence of excessive seepage appearing anywhere at the dam site (an embankment becoming saturated, seepage exiting on the downstream face of a dam) increasing in volume.

Although the remedy for some critical problems may be obvious (such as clearing a blocked spillway), the problems listed above generally require the services of a professional engineer familiar with the construction and maintenance of dams. The emergency action plan (discussed in Chapter 8) should be activated when any of the above conditions are noted.

7.1.2 Required Maintenance at Earliest Possible Date

The following maintenance should be completed as soon as possible after the defective condition is noted:

- Remove all underbrush and trees from the dam, and establish a good grass cover.
- Fill animal burrows.
- Restore and reseed eroded areas and gullies on embankment dams.
- Repair defective spillways, gates, valves, and other appurtenant features.

- Repair any concrete or metal components that have deteriorated, as soon as weather permits.

7.1.3 Continuing Maintenance

Several tasks should be performed continually:

- routine mowing and general maintenance
- maintenance and filling of any cracks and joints on concrete dams and in concrete spillways
- observation of any springs or areas of seepage, comparing quantity and quality (clarity) with prior observations
- inspection of the dam (as discussed in Chapter 5)
- monitoring of development in the watershed which would materially increase runoff from storms
- monitoring of development downstream and updating the emergency notification plan to include new houses or other occupied structures within the area

7.2 Specific Maintenance Items

7.2.1 Earthwork Maintenance and Repair

The surfaces of an earthen dam may deteriorate for several reasons. For example, wave action may cut into the upstream slope, vehicles may cause ruts in

the crest or slopes, or runoff waters may leave erosion gullies on the downstream slope. Other special problems, such as shrinkage cracks or rodent damage, may also occur. Damage of this nature must be repaired continually. The maintenance procedures described below are effective in repairing minor earthwork problems. However, this section is not intended to be a technical guide, and the methods discussed should not be used to solve serious problems. Conditions such as embankment slides, structural cracking, and sinkholes threaten the immediate safety of a dam and require immediate repair under the direction of an engineer.

The material selected for repairing embankments depends upon the purpose of the earthwork. Generally, earth should be free from vegetation, organic materials, trash, and large rocks. Most of the earth should be fine-grained soils or earth clods that easily break down when worked with compaction equipment. The intent is to use a material which, when compacted, forms a firm, solid mass, free from excessive voids.

If flow-resistant portions of an embankment are being repaired, materials that are high in clay or silt content should be used. If the area is to be free draining or highly permeable (riprap bedding, etc.), the material should have a higher percentage of sand and gravel. It is usually satisfactory to replace or repair damaged areas with soils similar to those originally in place.

An important soil property affecting compaction is moisture content. Soils that are too dry or too wet do not compact well. One may roughly test repair material by squeezing it into a tight ball. If the sample maintains its shape without cracking and falling apart (which means it is too dry), and without depositing excess water onto the hand (which means it is too wet), the moisture content is probably near the proper level.

Before placement of earth, prepare the repair area by removing all inappropriate

material. Clear vegetation such as brush, roots, and tree stumps, along with any large rocks or trash removed. Also, unsuitable earth, such as organic or loose soils, should be removed, so that the work surface consists of exposed, firm, clean embankment material.

Following cleanup, shape and dress the affected area so that the new fill can be compacted and will properly tie into the existing fill. If possible, trim slopes and roughen surfaces by scarifying or plowing to improve the bond between the new and existing fill and to provide a good base to compact against. Grade the slopes in a direction such that the soil ridges are parallel to the length of the dam—this will help to minimize or reduce rill erosion. Roughening in the wrong direction will likely increase rill erosion.

Place soils in loose layers up to eight inches thick and compacted manually or mechanically to form a dense mass free from large rock or organic material. Maintain soil moisture in the proper range. The fill should be watered and mixed to the proper wetness or scarified and allowed to dry if too wet.

During backfilling, take care that the fill does not become too wet from rainstorm runoff. Direct runoff away from the work area and overflow repair areas so that the fill maintains a crown that will shed water.

As mentioned earlier, occasionally minor cracks will form in an earthen dam because of surface drying. These are called *desiccation* (drying) cracks and should not be confused with *structural* or *settlement* cracks. Drying cracks are usually parallel to the main axis of the dam, typically near the upstream or downstream shoulders of the crest. These cracks often run intermittently along the length of the dam and may be up to four feet deep. Drying cracks can be distinguished from more serious structural cracks because the former are

usually no wider than a few inches and have edges that are not offset vertically.

As a precaution, initially monitor suspected desiccation cracks with the same care used for other types of cracks. The problem area should be marked with survey stakes, and monitoring pins should be installed on either side of the crack to allow recording of any changes in width or vertical offset. Once you are satisfied that observed cracking is the result of shrinkage or drying, you may stop monitoring.

These cracks should close as climatic or soil moisture conditions change. If they do not, it may be necessary to backfill the cracks to prevent entry of surface moisture, which could result in saturation of the dam. The cracks may be simply filled with earth that is tamped in place with hand or tools. It is also recommended that the crest of a dam be graded to direct runoff waters away from areas damaged by drying cracks.

As Chapter 5 suggests, erosion is one of the most common maintenance problems at embankment structures. Erosion is a natural process and its continuous forces will eventually wear down almost any surface or structure. Periodic and timely maintenance is essential to prevent continuous deterioration and possible failure.

Sturdy sod, free from weeds and brush, is an effective means of preventing erosion. Embankment slopes are normally designed and constructed so that surface drainage will be spread out in thin layers (sheet flow) on the grassy cover. When embankment sod is in poor condition or flows are concentrated at any location, the resulting erosion will leave rills and gullies in the embankment slope. An owner should look for such areas and be aware of the problems that may develop. Eroded areas must be promptly repaired to prevent more serious damage to the embankment. Rills and gullies should be filled with

suitable soil (the upper four inches should be topsoil, if possible), compacted, and then seeded. The local Natural Resources Conservation Service office can help select the types of grass to use for protecting dam surfaces. Erosion in large gullies can be slowed by stacking bales of hay or straw across the gully until permanent repairs can be made.

Not only should eroded areas be repaired, but the cause of the erosion should be found to prevent a continuing maintenance problem. Erosion might be caused or aggravated by improper drainage, settlement, pedestrian traffic, animal burrows, or other factors. The cause of the erosion will have a direct bearing on the type of repair needed.

Paths due to pedestrian, livestock, or vehicular traffic (two- and four-wheeled) are a problem on many embankments. If a path has become established, vegetation will not provide adequate protection and more durable cover will be required unless traffic is eliminated. Small stones, asphalt, or concrete may be used effectively to cover footpaths. In addition, railroad ties or other beams of treated wood can be embedded into an embankment slope to form an inexpensive stairway. All vehicular traffic, except for maintenance, should be prohibited from the dam.

Erosion is also common at the point where an embankment and the concrete walls of a spillway or other structure meet. Poor compaction adjacent to such a wall during construction and subsequent settlement can result in an area along the wall that is lower than the grade of the embankment. Runoff, therefore, often concentrates along these structures, resulting in erosion. People also frequently walk along these walls, wearing down the vegetative cover. Possible solutions include regrading the area so that it slopes away from the wall, adding more resistant surface protection, or constructing wooden steps.

Adequate protection against erosion is also needed along the contact between the downstream face of an embankment and the abutments. Runoff from rainfall can concentrate in gutters constructed in these areas and can reach erosive velocities because of relatively steep slopes. Berms on the downstream face that collect surface water and empty into these gutters add to the runoff volume. Sod-surfaced gutters may not adequately prevent erosion in these areas. Paved concrete gutters may not be desirable either because they do not slow the water and can be undermined by erosion. Also, small animals often construct burrows underneath these gutters, adding to the erosion potential.

A well-graded mixture of rocks up to 9–12" in diameter (or larger), placed on a layer of sand (which serves as a filter), generally is the best protection for these gutters on small dams. Riprap covered with a thin concrete slurry has also been successful in preventing erosion on larger dams, and should be used if large stone is not available.

As with erosion around spillways, erosion adjacent to gutters results from improper construction or a poor design in which the finished gutter is too high with respect to adjacent ground—preventing much of the runoff from entering the gutter. Instead, the flow concentrates along the side of the gutter, eroding and potentially undermining it.

Care should be taken when replacing failed gutters or designing new gutters to assure that:

- The channel has adequate capacity.
- Adequate erosion protection and a satisfactory filter have been provided.
- Surface runoff can easily enter the gutter.
- The outlet is adequately protected from erosion.

7.2.2 Riprap Maintenance and Repair

A serious erosion problem called *benching* can develop on the upstream slope of a dam. Waves caused by high winds or high-speed boats can erode the exposed face of an embankment by repeatedly striking the surface just above the pool elevation, rushing up the slope, then tumbling back into the pool. This action erodes material from the face of the embankment and displaces it down the slope, creating a “bench.” Erosion of unprotected soil can be rapid and, during a severe storm, could lead to complete failure of a dam.

The upstream face of a dam is commonly protected against wave erosion and resultant benching by placement on the face of a layer of rock riprap over a layer of filter material. Sometimes, materials such as bituminous or concrete facing, bricks, or concrete blocks are used for this upstream slope protection. Protective benches are sometimes actually built into small dams by placing a berm (8–10 ft wide) along the upstream face a short distance below the normal pool level, supplying a surface on which wave energy can dissipate. Generally, however, rock riprap offers the most economical and effective protection.

Nonetheless, benching can occur in existing riprap if the embankment surface is not properly protected by a filter. Water running down the slope under the riprap can erode the embankment. Sections of riprap that have slumped downward are often signs of this kind of benching. Similarly, concrete facing used to protect slopes may fail because waves wash soil from beneath the slabs through joints and cracks. Detection is difficult because the voids are hidden, and failure may be sudden and extensive. Effective slope protection must prevent soil from being removed from the embankment.

When erosion occurs and benching develops on the upstream slope of a dam, repairs should be made as soon as possible. Lower the pool level and prepare the surface of the dam for repair. Have a small berm built across the face of the dam at the base of the new layer of protection to help hold the layer in place. The size of the berm needed depends on the thickness of the protective layer.

A riprap layer should extend a minimum of 3 ft below the lowest expected normal pool level. Otherwise, wave action during periods of low lake level will undermine and destroy the protection.

If rock riprap is used, it should consist of a heterogeneous mixture of irregular shaped stone placed over a sand and gravel filter. The biggest rock must be large and heavy enough to break up the energy of the maximum expected waves and hold smaller stones in place. (An engineer may have to be consulted to determine the proper size.) The smaller rocks help to fill the spaces between the larger pieces and to form a stable mass. The filter prevents soil particles on the embankment surface from being washed out through the spaces between the rocks in the riprap. If the filter material itself can be washed out through these voids and benching develops, two layers of filters may be required. The lower layer should be composed of sand or filter fabric to protect the soil surface and the upper layer should be composed of coarser materials.

A dam owner should expect some riprap deterioration because of weathering. Freezing and thawing, wetting and drying, abrasive wave action and other natural processes will eventually break down the material. Therefore, allocate sufficient funds for the regular replacement of riprap.

The useful life of riprap varies depending on the characteristics of the stone used. Thus, stone for riprap should be rock that is dense and well cemented.

When riprap breaks down, and erosion and beaching occur more often than once every three to five years, professional advice should be sought to design more effective slope protection.

7.2.3 Controlling Vegetation

Keep the entire dam clear of unwanted vegetation such as brush or trees. Excessive growth may cause several problems:

- It can obscure the surface of an embankment and prevent a thorough inspection of the dam.
- Large trees can be uprooted by high wind or erosion and leave large holes that can lead to breaching of the dam.
- Some root systems can decay and rot, creating passageways for water, and thus causing erosion.
- Growing root systems can lift concrete slabs or structures.
- Trees, brush, and weeds can prevent the growth of desirable grasses.
- Rodent habitats can develop.

When brush is cut down, it should be removed to permit a clear view of the embankment. Following removal of large brush or trees, also remove their leftover root systems, if possible, and properly fill and compact the resulting holes. In cases where they cannot be removed, treat root systems with herbicide (properly selected and applied) to retard further growth.

TCEQ personnel have consulted with the Texas Parks and Wildlife Department regarding effective herbicides for control of vegetation on dam structures. Appendix C recommends which herbicides to use and not to use, offers guidelines for applying them, and addresses concerns about endangered and threatened species.

According to the TPWD, the herbicides triclopyr (Remedy) and clopyralid (Reclaim) are effective in control of mesquite trees. Although these

are listed in the appendix as herbicides to avoid on dam structures, they are not considered toxic to fish and wildlife. The problems are high mobility in soil and concerns about water quality. Consequently, use extreme caution when applying these herbicides. Treatments should be localized (applications on individual plants), and every effort made to prevent overspraying.

The Brush Busters Program is a cooperative program of Texas Cooperative Extension and the Texas Agricultural Experiment Station for the development of brush-management technology. Specific guidance on the methods of treatment and spraying, equipment, equipment preparation, and herbicide mixtures related to mesquite trees are available online at <http://texnat.tamu.edu/BrushBusters/Mesquite.htm>.

After the removal of brush, cuttings may need to be burned, in which case you should notify the local fire department, forest service, or other agencies responsible for fire control. Also contact the TCEQ regional office for the area both to ascertain any burn notifications, authorizations, or requirements and to inform the agency of your intent to burn.

If properly maintained, grass is not only an effective means of controlling erosion—it also enhances the appearance of a dam and provides a surface that can be easily inspected. Grass roots and stems tend to trap fine sand and soil particles, forming an erosion-resistant layer once the plants are well established. Grass is least effective in areas of concentrated runoff or in areas subjected to wave action.

7.2.4 Controlling Livestock

Livestock should not be allowed to graze on an embankment surface. When soil is wet, stock can damage vegetation and disrupt the uniformity of the surface.

Moreover, livestock tend to walk in established paths and thus can promote severe erosion. Such paths should be regraded and seeded, and the livestock permanently fenced out of the area.

7.2.5 Controlling Animal Damage

Burrowing animals (beaver, nutria, muskrat, badgers, and otters) are naturally attracted to the habitats created by dams and reservoirs and can endanger the structural integrity and proper performance of embankments and spillways. The burrows and tunnels of these animals generally weaken earthen embankments and serve as pathways for seepage from the reservoir. This kind of damage has resulted in several failures of dams; therefore, controlling burrows is essential to their preservation.

The beaver is the most common source of burrowing damage to earthen embankments in Texas. Beavers usually construct their tunnels and dens in the banks surrounding the reservoir or in the dam. The main entrance to a beaver's den is generally 4–10 ft below the normal water level of the lake. The tunnel systems become very extensive as the colony grows, and embankment material located above these systems will eventually settle or collapse. Tunnels occasionally extend through a dam where pools of water are allowed to collect along its toe, and provide pathways for water to pass through the embankment.

Common signs of the presence of beaver include gnawed or cut vegetation around the waterline; burrows or sunken or collapsed areas in the crest or slopes of the embankment; and obstructions across spillways and inlets that produce unusual changes in the water level of the reservoir.

Barriers such as properly constructed riprap and filter layers offer the most practical protection from these animals.

When an animal tries to construct a burrow, the sand and gravel of a filter layer will cave in and discourage den building. Filter layers and riprap should extend at least three feet below the waterline. Heavy wire fencing laid flat against a slope and extending above and below the waterline can also be effective. Eliminating or reducing aquatic vegetation along a shoreline will also discourage habitation.

For assistance in removing the animals from your property, contact the nearest office of the Texas Wildlife Damage Management Service, whose personnel will assist the owner or will provide the name of a local trapper who will remove the animals, sometimes for little or no charge.

Methods of repairing rodent damage depend upon the nature of the damage but, in any case, extermination of the rodent population is the required first step. If the damage consists mostly of shallow holes scattered across an embankment, repair may be necessary to maintain the appearance of the dam, to keep runoff waters from infiltrating the dam, or to discourage rodents from subsequently returning to the embankment. In these cases, tamping of earth into the rodent hole should be sufficient repair. Soil should be placed as deeply as possible and compacted with a pole or shovel handle.

Large burrows on an embankment should be filled by mud packing. This simple, inexpensive method involves placing one or two lengths of metal stove or vent pipe vertically over the entrance of the den with a tight seal between the pipe and den. A mud-pack mixture is then poured into the pipe until the burrow and pipe are filled with the earth-water mixture. The pipe is removed and more dry earth is tamped into the den. The mud-pack mixture is made by adding water to a mixture of 90 percent earth and 10 percent cement until a slurry of thin cement is obtained. Plug all entrances with well-compacted earth and reestablish

vegetation. Eliminate dens promptly—one burrow can lead to failure of a dam.

Different repair measures are necessary if a dam has been damaged by extensive small rodent tunneling or by beaver, nutria, or muskrat activity. In these cases, it may be necessary to excavate the damaged area down to competent soil and repair as described in Section 7.2.1.

Occasionally, rodents will dig passages all the way through the embankment that could result in leakage of reservoir water, piping, and ultimate failure. In those cases, do not plug the downstream end of the tunnel since that will add to the saturation of the dam. Tunnels of rodents or ground squirrels will normally be above the phreatic surface with primary entrance on the downstream side of the dam, while those of beaver, nutria, and muskrat normally exist below or at the water surface with entrance on the upstream slope. If a rodent hole extends through the dam, first locate its upstream end. Excavate the area around the entrance and then backfill it with impervious material, plugging the passage entrance so that reservoir water is prevented from saturating the dam's interior. This should be considered a temporary repair. Excavation and backfilling of the entire tunnel or filling of the tunnel with cement grout are possible long-term solutions, but pressure cement grouting is an expensive and sometimes dangerous procedure. Indeed, pressure exerted during grouting can cause further damage to the embankment via hydraulic fracturing (an opening of cracks by high-pressure grouting). Thus, grouting should be performed only under the direction of an engineer.

7.2.6 Controlling Fire Ants

Fire ants have become one of the most serious pests in Texas. Fire ants require water to survive and have been found on dams throughout much of the eastern two-thirds of Texas. These ants can create

problems in the dam itself and with any of its electrical components.

In some habitats, fire ants can move as much or more soil as earthworms, thereby reducing soil compaction. Nest galleries can penetrate in a V-shaped pattern below the nest, penetrating as much as four feet deep in the soil. These galleries can create pathways for surface water to penetrate the dam, possibly resulting in internal erosion and collapse of the surface. The ants could also create pathways for water from the reservoir to flow through the dam when the reservoir level is high.

Fire ants left undisturbed can build mounds that become very large (10–12" in diameter) and tall (12–14 inches high). These can create problems for mowing. However, frequent mowing can induce the colonies to migrate to neighboring, undisturbed areas.

Fire ants often infest electrical equipment and utility housings, in which whole colonies will move at certain times of the year. Worker ants will import soil for nesting. This material can cause corrosion and interfere with maintenance operations. Ants chew on insulation and can cause short circuits or interfere with switching mechanisms, resulting in electrical components for operating gates and valves not working properly when needed. Ants nesting in these units are highly defensive of their colony and can be a medical threat to maintenance personnel.

Worker ants, which have an affinity for oscillating magnetic fields, can cause a particular problem when they enter switching mechanisms of electrical equipment. Once ants in a switching mechanism bridge the gap across an open switch, they are electrocuted. The shocked ants release communication chemicals or other signals that attract more worker ants. The result is that switching units can become tightly packed with the bodies of dead worker ants, causing a failure of the mechanism.

There are many options for managing fire ants. Use only pesticides labeled as suitable for the location you want to treat. Make every effort to avoid contaminating water with pesticides. For information on managing fire ants, contact:

Texas Imported Fire Ant
Applied Research and Education
412 Minnie Belle Heep Center
Attn: Bart Drees
Texas A&M University
College Station, Texas 77843-2475
979/845-7026
<<http://fireants.tamu.edu>>

7.2.7 Controlling Damage From Traffic

As mentioned earlier, vehicles driving across an embankment dam can create ruts in the crest if it is not surfaced with roadway material. The ruts can then collect water and cause saturation and softening of the dam. Other ruts may be formed by vehicles driving up and down a dam face; these can collect runoff and cause severe erosion. Vehicles, except for maintenance, should be banned from dam slopes and kept out by fences or barricades. Repair any ruts as soon as possible using the methods outlined in Section 7.2.1. Maintenance vehicles should only travel on the soil and grass portions of the dam when the surface is dry unless necessitated by an emergency.

7.2.8 Mechanical Maintenance

The safe and satisfactory operation of a dam depends on proper operation of its outlet works. Release of water from a dam is normally a frequent or ongoing function. However, at some reservoirs used for recreation, fish propagation, or other purposes that do not require continual release of water, an operable outlet provides the only means for the emergency

lowering of the reservoir and is therefore essential for safety.

If routine inspection of the outlet works indicates the need for maintenance, the work should be completed as soon as access can be gained. Postponing maintenance could result in damage to the installation, significantly reduce the useful life of the structure, and result in more extensive and more costly repairs when finally carried out. More importantly, failure to maintain an outlet system can lead directly to dam failure.

The simplest procedure to ensure the smooth operation of outlet gates is to operate all gates through their full range at least once—and preferably twice—annually. In fact, many manufacturers recommend operating gates as often as four times a year. Because operating gates under full reservoir pressure can result in large outlet discharges, schedule gate testing during periods of low storage, if possible, or else operate them during periods of low stream flow. If you expect large releases, only have the outlets tested after coordinating releases with the local floodplain administrator and other dam owners located downstream and after notifying downstream residents and water users.

Operation of the gates minimizes the buildup of rust in the operating mechanism and therefore the likelihood of its seizure. During this procedure:

- Check the mechanical parts of the hoisting mechanism—including drive gears, bearings, and wear plates—for adverse or excessive wear.
- Check all bolts, including anchor bolts, for tightness.
- Replace worn and corroded parts.
- Make mechanical and alignment adjustments as necessary.

The way the gate actually operates should also be noted. Rough, noisy, or erratic movement could be the first signs

of a developing problem. The causes of operational problems should be investigated and corrected immediately.

Excessive force should be neither needed nor applied to either raise or lower a gate. Most hoisting mechanisms are designed to operate satisfactorily with a maximum force of 40 pounds on the operating handle or wheel. If excessive force seems necessary, something may be binding the mechanical system. Excessive force may result in increased binding of the gate or damage to the outlet works. If there does seem to be undue resistance, the gate should be worked up and down repeatedly in short strokes until the binding ceases or the cause of the problem should be investigated. Of course, you should correct the problem as soon as possible to assure the continued operability of the gate.

If a gate does not properly seal when closed, debris may be lodged under or around the gate leaf or frame. Raise the gate at least two to three inches to flush the debris; then have the operator attempt to reclose the gate. This procedure should be repeated until proper sealing is achieved. However, if this problem or any other problem persists, consult a manufacturer's representative or engineer experienced in gate design and operation.

An outlet gate's operating mechanism should always be well-lubricated in accordance with the manufacturer's specifications. Proper lubrication will not only reduce wear in the mechanism, but also protect it against adverse weather. Gates with oil-filled stems (i.e., stems encased in a larger surrounding pipe) should be checked semiannually to assure the proper oil level is maintained. If such mechanisms are neglected, water could enter the encasement pipe through the lower oil seal and could cause failure of the upper or lower seals, which in turn could lead to the corrosion of both the gate stem and the interior of the encasement pipe.

The metal used in gate seats is usually brass, stainless steel, bronze, or other rust-resistant alloys. Older or smaller gates may not be fitted with seats, making them susceptible to rusting at the contact surfaces between the gate leaf and gate frame. Operation of gates should prevent excessive rust buildup or seizure.

For satisfactory operation, a gate stem must be maintained in proper alignment with the gate and hoisting mechanism. Proper alignment and support are supplied by stem guides in sufficient number and properly spaced along the stem. Stem guides are brackets or bearings through which a stem passes. They both prevent lateral movement of the stem and bending or buckling when a stem is subjected to compression as a gate is closing.

Check the alignment of a stem should be checked during routine inspections by sighting along the length of the stem, or more accurately by dropping a plumb line from a point near the top of the stem to the other end. The stem should be checked in both an upstream–downstream direction as well as in a lateral direction to ensure straightness. While checking alignment, all gate stem guide anchors and adjusting bolts should be checked for tightness. A loose guide provides no support to the stem and could cause it to buckle at that point.

If, during normal inspection, the stem appears out of alignment, the cause should be remedied. Completely lower the gate and take all tension or compression off the stem. Loosen any misaligned stem guides and make them move freely. Then operate the hoisting mechanism so as to put tension on the stem, thereby straightening it, but do not open the gate. Then align and fasten the affected guides so that the stem passes exactly through their centers.

Many outlet gates are equipped with wedges that hold the gate leaf tightly against the gate frame as the gate is closed, thus ensuring a tight seal. Through years

of use, gate seats may become worn, causing the gate to leak increasingly. If an installation has a wedge system, the leakage may be substantially reduced or eliminated by readjusting the wedges.

Because adjustment of these gates is complicated, inexperienced personnel can cause extensive damage to one. Improper adjustment could cause premature seating of the gate, possible scoring of the seats, binding, vibration, leakage, uneven closing, or damage to wedges or gate guides. Thus, only experienced personnel should perform adjustments; consult a gate supplier or manufacturer to obtain names of persons experienced in such work.

Ice can exert great force on and cause significant damage to an outlet gate leaf. Storage levels in a reservoir during winter should be low enough that ice cannot form behind a gate. To prevent ice damage, the winter water level should be significantly higher than the gate if storage is maintained through the winter months, or, if the reservoir is to remain empty over the winter, the outlet should be fully open. If operations call for the water level to move across the gate during the winter, a bubbler or other anti-icing system may be needed.

7.2.9 Electrical Maintenance

Electricity is typically used at a dam for lighting and to operate outlet gates, spillway gates, recording equipment, and other miscellaneous equipment.

It is important that an electrical system be well maintained, including a thorough check of fuses and a test of the system to ensure that all parts are properly functioning. The system should be free from moisture and dirt, and wiring should be checked for corrosion and mineral deposits. Carry out any necessary repairs immediately, and keep records of the work. Maintain generators used for auxiliary emergency power—change the

oil, check the batteries and antifreeze and make sure fuel is readily available.

7.2.10 Cleaning

As already suggested, the proper operation of spillways, sluiceways, approach channels, inlet and outlet structures, stilling basins, discharge conduit, dam slopes, trashracks, and debris-control devices require regular and thorough cleaning and removal of debris. Cleaning is especially important after upstream storms, which tend to send more debris into the reservoir.

7.1.11 Concrete Maintenance

Also as mentioned, periodic maintenance should be performed on all concrete

surfaces to repair deteriorated areas. Repair deteriorated concrete immediately when noted; it is most easily repaired in its early stages. Deterioration can accelerate and, if left unattended, can result in serious problems or dam failure. Consult an experienced engineer to determine both the extent of deterioration and the proper method of repair. Seal joints and cracks in concrete structures to avoid damage beneath the concrete.

7.2.12 Metal Component Maintenance

All exposed, bare ferrous metal on an outlet installation, whether submerged or exposed to air, will tend to rust. To prevent corrosion, exposed ferrous metals must be either appropriately painted

(following the paint manufacturer's directions) or heavily greased.

When areas are repainted, ensure that paint does not get on gate seats, wedges, or stems (where they pass through the stem guides), or on other friction surfaces where paint could cause binding. Use heavy grease on surfaces where binding can occur. Because rust is especially damaging to contact surfaces, remove existing rust before the periodic application of grease.

Chapter 8: Guidelines for an Emergency Action Plan

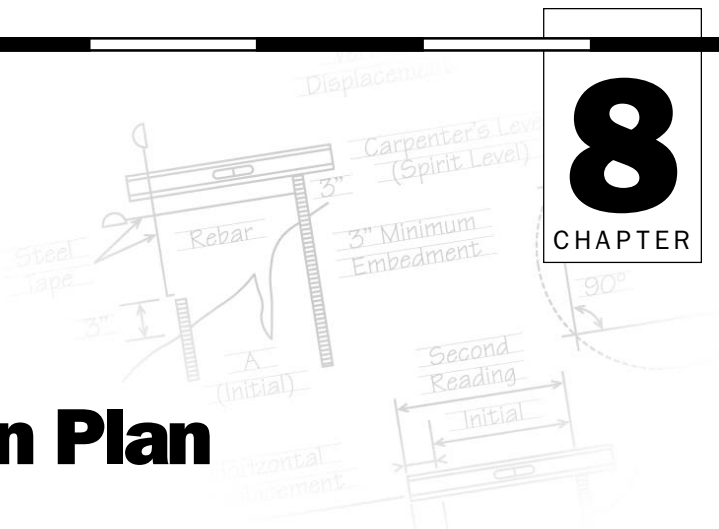

8.0 General

The primary goal of the state's dam safety program is to reduce the risk to lives and property from the consequences of dam failure. Although most dam owners have a high level of confidence in the structures they own and are certain their dams will not fail, history has shown that on occasion dams do fail and that often these failures cause extensive property damage—and sometimes death. A dam owner is responsible for keeping these threats to a minimum. A carefully conceived and implemented emergency action plan (EAP) is one positive step you, the dam owner, can take to accomplish dam safety objectives and to protect your investment and reduce potential liability.

An emergency action plan is not a substitute for proper maintenance or remedial construction, but it facilitates recognition of dam-safety problems as they develop and establishes nonstructural means to minimize risk of loss of life and reduce property damage. A plan is essential for dams which have a high-hazard potential and should also be prepared for significant hazard dams. The guidelines explained herein are for the purpose of defining the requirements of an acceptable emergency action plan and for facilitating its preparation, distribution, annual testing and update.

Make use of the portions of these guidelines that apply to your own dam. The Texas Dam Safety Program has

prepared separate outlines of an EAP for small, intermediate, and large dams.

Submit a draft copy of the plan to the Texas Dam Safety Program for review prior to final publication at the following address:

Dam Safety Program, MC 174
Texas Commission on
Environmental Quality
P.O. Box 13087
Austin, TX 78711-3087
Telephone: 512 -239-5195

It is recommended that the plan be kept in a three-ring binder, for simplicity of updating, as it will allow the quick and easy replacement of revised pages and the removal of obsolete ones.

8.1 Contents of Guidelines

An EAP should contain:

- title page
- table of contents
- statement of purpose
- description of project
- notification flowchart
- emergency detection, evaluation, and classification
- responsibilities
- preparedness
- inundation maps
- implementation

8.2 Title Page

The title page shall identify the document as an EAP and specify the dam

for which it is developed. Include the owner's name and the inventory number for the dam.

8.3 Table of Contents

The table of contents should list all major items, including any appendixes for notification flowcharts, tables, and inundation maps.

8.4 Purpose

The purpose of an emergency action plan is to provide a systematic means to:

- Identify emergency conditions threatening a dam.
- Expedite effective responses to prevent failure.
- Prevent or reduce loss of life and property damage should failure occur.

This purpose should be stated concisely in the EAP.

8.5 Description of Project

A description of the project and its location shall include:

- a project or vicinity map;
- a drawing showing the project features;
- any significant upstream or downstream dam; and
- downstream communities potentially affected by a dam failure or by flooding as a result of large operational releases.

8.6 Notification Flowchart

A notification flowchart should identify who is to be notified, by whom, and in what order.

As owner, it is your responsibility to identify distress conditions at the dam and to notify all affected political jurisdictions and appropriate state and federal agencies of the condition and its possible consequences.

It is normally the responsibility of local governments, upon receiving such notification, to warn the public, make recommendations about evacuation, and offer shelter to area residents. There are instances, however, when the dam owner should more appropriately warn certain individuals instead of, or in addition to, relying on local government officials, particularly with small dams that may only affect a few people.

Prompt emergency notification requires:

- the identification of all affected jurisdictions
- the development and annual (or more frequent) updating of names, telephone numbers, call signs, and radio frequencies of individuals and agencies to contact; and
- the development of primary and alternate procedures for notification or warning regardless of time of day, day of the week, or weather.

When developing the notification flowchart, call the following parties to determine the appropriate contacts and phone numbers for key agencies that need to be notified in the event of an emergency:

- Governor's Division of Emergency Management, Department of Public Safety
Frank Cantu
512-424-2455

- National Weather Service
Ben Weiger
817-978-1100 x 118
- TCEQ's Dam Safety Program
Warren D. Samuelson, P.E.
512-239-5195

In the event that an emergency condition is declared at a dam, you, the owner, or the operator will initiate emergency notification. As far as possible, use the existing communication and warning systems operated by the Texas Department of Public Safety and local governments.

Develop information on potential inundation areas as described in Section 8.10.

The notification element of an emergency action plan should be brief, simple, and easy to implement under any conditions. Sample notification messages and sample public affairs news releases are attached as Tables 8.1 and 8.2 respectively. Use the appropriate notification message when contacting key officials about an emergency condition at a dam.

8.7 Emergency Detection, Evaluation, and Classifications

The EAP should indicate procedures for timely and reliable detection, evaluation, and classification of an existing or potential emergency situation, listing the conditions, events, or measures for detection of an existing or potential emergency. Incorporate an assessment of the dam, including its vulnerability to all appropriate known emergency conditions such as severe thunderstorms with lightning and excessive rains, hurricanes, tornadoes, earthquakes, etc., as well as a listing and explanation of problem indicators.

As owner, you are responsible for regularly monitoring the condition of your dam and correcting any deficiencies. The plan must include a routine inspection schedule

and name the person or position responsible for the inspection; it should emphasize indicators of the onset of problems that might cause failure of the dam:

- slumping, sloughing, or slides on the dam or the abutment
- cloudy or dirty seepage or seepage with an increase in flow, boils, piping, or bogs
- seepage around conduits
- cracks, settlement, misalignment, or sinkholes
- erosion or riprap displacement
- animal burrows, especially those associated with beavers or nutria
- growth of trees and brush
- failure of operating equipment
- abnormal instrumentation readings
- leakage of water into the intake tower
- undermining of spillways
- overtopping of the dam

The plan must address what action to take and what resources will be used when one of these indicators is observed and how quickly you or your responsible agent is to report the problem. Keep records relating to any of the indicators listed above to determine if changes are occurring. This will permit an intelligent assessment of the problems and the proper implementation of the emergency action plan. However, if you determine that failure is at all possible, report the situation immediately to the Texas Dam Safety Program and immediately implement all applicable notification procedures and emergency actions.

8.8 Responsibilities

The EAP is to identify:

- who is responsible for accomplishing each of the required emergency actions so as to meet all plan requirements;
- who is in charge of emergency response actions;
- communication and coordination channels;

- the location of the command post, control room, or emergency operating center; and
- lines of succession and assumptions of responsibility necessary to ensure uninterrupted emergency-response actions under any conditions.

8.9 Preparedness

The EAP should identify ways of preparing for an emergency, of increasing response readiness in a uniform and coordinated manner, and helping to reduce the effects of a dam failure. The goal is maximum readiness to respond in a minimum amount of time.

Categorize potential emergencies into phases or conditions and identify specific actions to reduce the possibility of either underreacting or overreacting to a given situation. List anticipated failure situations and appropriate responses, such as:

- **Emergency Water Release**—The release of water at the dam to lower lake levels is a normal procedure. An emergency release (i.e., in excess of normal) could flood certain downstream areas.
- **Watch Condition**—A problem has been detected at the dam which requires constant monitoring or immediate action to repair or correct. At this time, the distress condition is manageable by dam personnel. A watch condition will continue until the problem is corrected, or a possible-dam-failure warning is issued.
- **Possible-Dam-Failure Warning**—A watch condition that is progressively getting worse. Efforts to correct the situation will continue but a possibility now exists that the dam could fail if these efforts are unsuccessful. There is no immediate danger; however, if conditions continue to deteriorate, the dam could fail.

- **Imminent-Dam-Failure Warning**—You (the owner) or the operator has determined that conditions will progress to failure of the dam and an uncontrollable release of the reservoir. The dam will most likely fail regardless of what immediate measures are taken.
- **Dam Failure**—The dam has failed and a flood wave is now moving downstream. Flooding will start immediately and will continue to move downstream until water levels at the reservoir are stabilized. Massive destruction can be expected from the flood wave and evacuation of downstream areas should continue in accordance with local plans.

The EAP should also identify:

- support capabilities, such as personnel or organizations that can provide assistance and the procedures for contacting them;
- the existence and location of supplies and equipment available for use in remedial actions;
- procedures for emergency purchase or procurement of supplies and equipment needed for remedial actions; and
- remedial construction and other activities to prevent a failure of the dam.

8.10 Inundation Maps

Inundation maps showing potential areas of flooding from a dam failure are essential in local warning and evacuation planning and must be included with the emergency action plan. The inundation maps shall delineate areas that would be flooded as a result of a dam failure and shall include the time to flood (the time from the breach to the time that critical structures are flooded) and the time to peak flow. Contact the Texas Dam Safety Program for details of preparing these maps.

USGS 1:24,000 maps are generally suitable, though often out of date in the

structures and major infrastructure they depict. Aerial photographs, if available with reasonable clarity and scale, can also be used as a background for inundation maps. Topographic and aerial maps for Texas can be found online at the Texas Natural Resource Information Service, <www.tnris.state.tx.us>.

8.11 Implementation

After completing the plan, take steps to implement it. Supply copies of the completed plan to the TCEQ and other appropriate officials. The local National Weather Service office should receive a copy of the inundation maps to allow development of customized watch and warning messages. Schedule briefings with local officials to facilitate the incorporation of planning information into local-government emergency management plans.

Next, schedule training for the employees associated with the dam to familiarize them with the plan. Address:

- how to use the plan
- how to identify problems and their severity
- how to use the notification procedures and the communications equipment
- what resources are available
- the importance of employees' roles during emergencies
- the importance of updating downstream information

Also, develop a drill that rehearses the plan in an exercise. Schedule exercises yearly to keep employees familiar with the plan and to eliminate any potential problems. Coordinate with state and local officials before any test of the plan.

Conduct a *tabletop exercise* at least once every five years in the form of a meeting between you, the owner, and state and local emergency-management officials in a conference room. Begin the exercise

with a description of a simulated event and proceed to discussions among the participants to evaluate the EAP and response procedures, and to resolve concerns about coordination and responsibilities.

An annual review and evaluation of the plan is recommended. At that time, update the notification procedures to include any changes in names and telephone numbers of staff, local officials,

and downstream residents, and include any new problems. Submit revisions to the plan to the TCEQ and appropriate state and local government officials.

Table 8.1
Sample Notification Messages

A. **EMERGENCY WATER RELEASE.** This is a message about a dam emergency. (owner's name) at (name of dam) Dam, Texas, ID TX____, (has/have) declared a need for an emergency water release. There is no immediate danger of the dam failing. Releases to lower the lake level (began/will begin) at (time/date). (Minor) flooding is expected along the (stream name). (Briefly describe the problem/reason). For verification, call the phone numbers listed on page ___ of the flood-emergency plan for the (name of dam) Dam. Additional information will be provided as it becomes available.

B. **WATCH CONDITION.** This is a message about a dam emergency. (owner's name) at (name of dam) Dam, located at (approximate location), Texas, ID TX____, (has/have) declared a watch condition. (Briefly describe the problem/reason.) There is no immediate danger of the dam failing; however, the potential for failure does exist. Emergency water releases to lower the lake level (are / are not) planned. Request you initiate appropriate emergency management procedures. For verification, call the phone numbers listed on page ___ of the flood-emergency plan for the (name of dam) Dam. Additional information will be provided as it becomes available.

C. **POSSIBLE DAM FAILURE WARNING.** This is a message about a dam emergency. (owner's name) at (name of dam) Dam, located at (approximate location), Texas, ID TX____, (has/have) declared a possible dam failure warning condition. (Briefly describe the problem/reason.) There is a possibility that the dam could fail. Attempts to save the dam are under way, but their success cannot be determined as yet. Emergency water releases to lower the lake level (are / are not) planned. Request you initiate emergency management procedures and prepare for evacuation of threatened areas. If (name of dam) Dam fails, flooding will occur along the (stream name). For verification, call the phone numbers listed on page ___ of the flood-emergency plan for the (name of dam) Dam. Additional information will be provided as it becomes available.

D. **IMMINENT DAM FAILURE WARNING.** Urgent! This is a message about a dam emergency. The (name of dam) Dam, located at (approximate location), is in imminent danger of failing. Attempts to save the dam will continue, but their success is considered unlikely. Request you initiate emergency management procedures and begin evacuation of threatened areas. It is probable that the dam will fail in (number) hours. If (name of dam) Dam fails, a flood wave will move down the (stream name), through (cities), and on down the (stream name). For verification, call the phone numbers listed on page ___ of the flood-emergency plan for the (name of dam) Dam.

E. **DAM FAILURE MESSAGE.** Emergency! This is an emergency message about a dam failure. This is (owner's name). (name of dam) Dam, located at (approximate location), has failed. A flood wave is now moving down the (stream name) and the peak will reach (list prominent points and the time to reach them). Evacuate threatened areas immediately. For verification, call the phone numbers listed on page ___ of the flood-emergency plan for the (name of dam) Dam.

Table 8.2
Sample News Release

Note: Coordinate with the Texas Department of Public Safety prior to release.

- A. **ANNOUNCEMENT FOR EMERGENCY WATER RELEASE.** (owner's name) at (name of dam) declared a need for emergency water releases to lower the lake level. (Briefly describe the problem/reason.) There is no immediate danger of the dam failing. Releases of (volume) cubic feet per second (began/will begin) at (time/date). (Minor) flooding is expected along the (stream names).
- B. **ANNOUNCEMENT FOR SLOWLY DEVELOPING WATCH CONDITION.** (owner's name) declared a watch condition at (name of dam) Dam as of (time and date). (Describe the problem.) There is no immediate danger of the dam failing; however, the potential does exist. (Describe what actions are being taken to monitor/control the situation.) (State how much, if any, water releases are being made.)
- C. **ANNOUNCEMENT FOR POSSIBLE DAM FAILURE WARNING CONDITION.** (owner's name) declared a possible dam failure warning condition at (name of dam) Dam as of (time and date). (Describe the problem.) There is a possibility that the dam could fail. Attempts to save the dam are under way, but their success cannot be determined as of yet. (Describe what actions are being taken to monitor/control the situation.) (State how much, if any, water is being released.) Additional news releases will follow as information is received.
- D. **ANNOUNCEMENT FOR IMMINENT FAILURE WARNING CONDITION.** Urgent! (owner's name) announced at (time and date) that (name of dam) Dam is in imminent danger of failing. (Describe the problem.) Attempts to save the dam will continue, but their success is considered unlikely. (Describe what actions are being taken to monitor/control the situation.) It is probable that the dam will fail in (number) hours. Residents of (city) and other low areas along the (stream names) should prepare for immediate evacuation. Additional news releases will follow as information is received.
- E. **ANNOUNCEMENT OF A DAM FAILURE.** Emergency! (Name of dam) Dam failed at (time and date). Residents who have not yet evacuated should immediately evacuate low areas along the (list prominent points and the time to reach them). Additional news releases will follow as information is received.

9

CHAPTER

Chapter 9: Guidelines for Operations

9.0 General

An operation plan details each of the safety-program components outlined in Chapter 4 and detailed in Chapters 5 through 8. The extent of an operation plan depends on the complexity of the dam itself—factors such as dam size, the number and type of appurtenances, and operating mechanisms.

The operation of a dam may involve adjusting the reservoir level, controlling debris by opening and closing valves, keeping records, and, in general, ensuring public safety. Proper operation procedures are extremely important for maintaining a safe structure. Many small dams do not need a full-time operator, but should be checked regularly. Special operational procedures to be followed during an emergency should be posted, particularly if the owner/operator is not always available.

9.1 Plan Guidelines

Establishing an operations procedure or plan calls for detailed documentation of the following:

- data on the physical characteristics of dam and reservoir
- descriptions of dam components (Chapter 2)
- operations instructions for operable mechanisms (Chapter 9)
- inspection guidelines (Chapter 5)
- instrumentation and monitoring guidelines (Chapter 6)
- maintenance guidelines (Chapter 7)

- guidelines for emergency operations (Chapter 8)
- bibliographical information (Bibliography)

As recommended in Chapter 4, collection and review of existing information on the dam's design, construction, and structural characteristics comprise the first step in developing a dam-safety program. Guidelines for inspections, monitoring, maintenance, and emergency-action planning appear in the other chapters as indicated.

The operation plan should have several separate sections:

A. Background Data

1. Vital dam statistics
2. Description of appurtenances

B. Operating Instructions and Records

1. Operating instructions for operable mechanisms
2. Inspection instructions and forms
3. Monitoring instructions and forms
4. Maintenance instructions and forms
5. Bibliography
6. Telephone list

C. Emergency Action Plan

Sections A and B are described briefly below and a schedule of routine tasks is included. Instructions are included for frequent inspections, monitoring, and follow-up maintenance. The emergency action plan is discussed in Chapter 8.

9.1.1 Background Data

1. Vital dam statistics include:
 - a. General

- type of dam
 - height of dam
 - length and width of crest
 - location of instrumentation
 - angles of upstream and downstream slopes
 - available freeboard (area between the design flood and the top of dam)
 - capacity tables for reservoir and inflow and outflow works
 - elevation of top of dam
 - county location and distance to the nearest city
 - stream name
 - year completed
 - hazard classification
 - location of toe drain outlets
- b. Spillway
- type of spillway
 - length of spillway
 - spillway channel elevation
 - normal pool elevation
 - available freeboard
 - maximum observed flow and date of observation
 - discharge tables for spillway
 - location of spillway drains
- c. Outlet
- size, configuration, and type of outlet
 - size and type of outlet control device
 - discharge tables for outlet
 - elevation of inlet invert
 - elevation of outlet invert (the bottom surface of a conduit or a channel)

9.1.2 Operating Instructions and Records

Instructions for operable mechanisms.

The plan should provide complete, clear, step-by-step instructions for operating all mechanisms associated with a dam, including the outlet control valve and spillway gates, if any. It should emphasize proper sequences and include sketches, drawings, and photographs to identify handles, cranks, buttons, etc. It should also list the correct method of opening and closing guard gates, gate usage during low and high flow, openings at which excessive vibrations are experienced, and operating problems peculiar to a specific gate. For hydraulic and electric gates, the plan should supply a schematic diagram showing each component (including backup equipment) and its place in the operating sequence.

The plan should give instruction on the general operation of the reservoir, including the regulation of inflow and outlet ditches, stating the maximum pool levels allowable at different times of the year, maximum and minimum carryover storage, and maximum and minimum permissible outlet releases. The instructions should also describe operation of the outlet to limit or prevent excessive spillway flow, and the method for periodic drainage of the reservoir to permit thorough inspection of the outlets or upstream slope.

Inspection and instrumentation. The plan should also supply a set of clear, step-by-step instructions for a comprehensive inspection of the dam and its surroundings. Record data on forms like those in the Appendixes, keeping copies of all completed inspection records and photographs.

Monitoring instructions. Prepare clear instructions on how to use monitoring instruments and how to take measurements at monitoring points; include a map identifying each instrument and monitoring point and forms for recording the data.

Keep the monitoring points themselves, plus any seepage or other areas needing special attention, clear of obscuring growth. The points should be permanently marked so they can be found during inspection. The help of a qualified engineer will be useful in developing this section.

Monitoring can only be beneficial if the observations are recorded in an orderly way and form a clear record of performance. Thus, plotting or charting some of the readings will be necessary. The plan should give instructions on how to make and record each measurement or observation. If your own engineer is not going to plot or chart the data, develop instructions and forms to allow yourself, an operator, or maintenance personnel to do this work. An experienced consulting engineer may be helpful in preparing the needed formats.

Maintenance instructions. The plan should give instructions for periodic maintenance in detail, so that new personnel can understand the task and experienced personnel can verify that they have completed the work properly. See Table 9.1 for a schedule of routine tasks. List all needed maintenance work. Include the tasks described in Chapter 7, such as:

1. removing brush and trees
2. removing debris
3. mowing and trimming
4. regrading the crest and access roads
5. removing harmful rodents
6. operating and lubricating gates
7. adding riprap when needed
8. sealing joints in concrete facings
9. cleaning drainpipes and outlets
10. maintaining monitoring points
11. maintaining the security of operating equipment

Bibliography. The plan should catalog all available reference material in a single list. Include the title, the author or agency responsible for publication, the date and place of publication, and the permanent location of the material (for example, *filings*

cabinet in basement) for each resource. Even materials without titles or authors, such as photographs and maintenance information, should be listed.

Telephone List. A comprehensive up-to-date listing of important telephone numbers should be maintained and include numbers for:

- the owner's and operator's home, office, mobile, pager, and any other phones
- employees actively involved with the dam
- the local emergency management agency
- the Texas Department of Public Safety
- local police and fire departments
- the Texas Dam Safety Program
- qualified local engineering consultants
- downstream residents
- a contractor with access to adequate equipment and material

9.2 Schedule of Routine Tasks

Establish a schedule that includes both day-to-day tasks and tasks performed less frequently during the year. Such a schedule serves to formalize inspection and maintenance procedures and makes it easy to determine when a task should be done. As suggested in Table 9.1, the frequency of a required task is often dependent upon the hazard classification of the dam (see Chapter 3).

9.3 Record Keeping

As already suggested, operating a dam should include keeping accurate records of:

1. **Observations**—Record all observations. Periodic observation of seepage is particularly important. Again, photographs are valuable for recording observations and documenting changes. Record the dates the photographs and observations were made.

Table 9.1
Operation Plan—Schedule of Routine Tasks
Hazard Classifications

Frequency (minimum)	CATEGORY 1 High Hazard <i>(many lives lost excessive damage)</i>	CATEGORY 2 Significant Hazard <i>(few lives lost appreciable damage)</i>	CATEGORY 3 Low Hazard <i>(no lives lost minimal damage)</i>
Daily	Surveillance.	—	—
Weekly	Monitor seepage.	Surveillance.	—
Monthly	Collect & examine observation well or other data.	Collect & examine observation well data.	Surveillance. Monitor seepage. Collect & examine observation well data.
Quarterly	Inspect visually.	Inspect visually.	—
Bi Annually	Test outlet & spillway components.	—	—
Annually	Inspection by engineer. Check alignments & movements.	Inspection by engineer. Test outlet & spillway components. Check alignments & movements.	Visual inspection. Test outlet.
As Required	Routine maintenance & additional inspections.	Routine maintenance & additional inspections.	Routine maintenance & additional inspections. Check alignments & movements.
Immediately After Floods & Earthquakes	Additional inspections.	Additional inspections.	Additional inspections.

2. **Maintenance**—Written records of maintenance and major repairs are important for evaluating the safety of a dam.
3. **Rainfall and Water Levels**—A record of the date, time, and maximum elevation of extremely high levels of the lake and associated rainfall or runoff is especially helpful in evaluating the performance of a dam and its spillway system. In particular, keep records for reservoirs that have widely fluctuating water levels.
4. **Drawdown**—Keep a record of the amount, rate, and reason for any drawdown of the reservoir level.
5. **Other Procedures**—Maintain a complete record of all operating procedures.

Chapter 10: Reducing the Consequences of Dam Failure

10.0 Supplements to a Dam-Safety Program

This manual has stressed safety as both a fundamental need and a prime responsibility of the dam owner. Developing an effective safety program is the single most important measure you, the owner, can take to reduce the possibility or consequences of dam failure. However, on a national scale, the level of dam safety is still far from acceptable. Losses are continuing to increase and may intensify as population growth and migration continue. From the perspectives of the nation and the dam owner alike, other steps are needed to reduce the risk of loss of life and property and minimize the potential subsequent liability.

Liabilities that arise following a dam failure strongly affect both organizations and people, governments and dam owners. Determination of liability is the legal means developed by society to recover damages due to a wrong (in this case, lack of dam safety). A thorough understanding of this legal process can help you decide on measures to reduce liability.

A discussion of liability and its relation to a dam owner is presented below, followed by a discussion of three important measures beyond that of individual dam safety that dam owners can promote to reduce liability—the use of insurance, the provision of governmental assistance, and the use of consultants.

10.1 Liability

The following discussion reviews general principles concerning liability and the operation of reservoirs. Liability in specific instances, however, is highly dependent upon the nature and construction of the dam, the particular circumstances surrounding the accident, the owner's action or failure to act, and the jurisdiction in which the reservoir is located.

In the event of a dam failure, the most commonly used theories to be pursued in litigation are negligence and strict liability. The choice will depend upon the law of the particular jurisdiction.

The liability of an owner of a reservoir is considered general civil (“tort”) liability. A tort is simply a civil wrong for which an injured party may recover damages from the responsible party. In most circumstances, simply causing damage is not a sufficient basis for the imposition of liability. Negligence must accompany the injury before liability is incurred. However, negligence is not a fixed concept; it has been modified and changed by court decisions over the years. In simplest terms, it has been described as the violation of a duty to act as a reasonable and prudent person would act; a violation which directly results in damage to another.

The questions of what duty is imposed by society and what standard of reasonable care is imposed by that duty have undergone enormous scrutiny and changes over the past 40 years. In many instances the duty to make a product safe

or the duty to ensure that one's property does not pose a danger to others has significantly increased.

While the concept of negligence has substantially broadened, changes in the limits of negligence do not directly affect dam owners in those jurisdictions where a separate basis of liability has long been imposed upon them. This standard, “strict liability,” is based not on fault or negligence, but solely upon resulting damage, regardless of fault. Strict liability is generally applied to activities deemed extremely hazardous and not capable of being rendered reasonably safe.

The whole concept of strict liability was first established in a case involving a reservoir—the 1866 English case *Fletcher v. Rylands*, L.R. 1, Ex. 265. A reservoir was built in the vicinity of abandoned coal mines; the water from the reservoir found its way into the abandoned shafts and from there into active shafts, causing damage. Under present legal thought, the basis of liability for such an occurrence may well be negligent design (i.e., failure to adequately investigate the surrounding circumstances at the time the reservoir was built). However, the actual decision assumed that no one could have known the abandoned mine shafts existed and specifically determined that the owner was not negligent. Nonetheless, the English court established the concept of strict liability for reservoir owners, and the owner of the reservoir was found liable for the escape of water from the reservoir, regardless of fault.

The holding in *Fletcher v. Rylands* has subsequently been adopted by many, but not all, U.S. courts and has been cited when similar circumstances are considered. It is the basis for imposing liability on the owner of a reservoir for all damages caused, regardless of fault and without a need to prove negligence.

Thus, with a very limited number of exceptions, the general principle regarding liability for the owner or operator of a reservoir (in a jurisdiction which recognizes strict liability) is:

If water escapes from a dam, regardless of fault, the owner is responsible for all damages sustained.

Note, however, that all of the discussion concerning compensation for damages due to release of water from a reservoir deal solely with water that has previously been stored. In all circumstances to date—and in most states by specific statute—a dam owner may pass on all natural flood waters without incurring any liability downstream.

Strict liability has two relatively narrow exceptions: acts of God and intentional acts of third parties over whom the owner had no control. While acts of God are recognized as a defense, they do not include all natural occurrences over which the owner had no control, but are more narrowly limited to over which the owner had no control and could not have anticipated using available expertise. The other exception—intentional acts of third parties—was established by the Wyoming Supreme Court in the *Wheatland* case [*Wheatland Irrigation District v. McGuire*, 537P.2d 1128 (1975)]. An irrigation district asserted that its reservoir had been damaged by saboteurs, and the Wyoming Supreme Court recognized that illegal, intentional acts by third parties which the owner

could not protect against or anticipate were a viable defense to strict liability.

Still, where there is no remedial legislation, the circumstances in which the reservoir owner is not liable for all damages caused by the leaking or breaking of a dam are severely limited.

While the standard of strict liability imposed on a reservoir owner affords extremely limited relief, several states have enacted legislation that limits liability for damages in many instances. In many other states, by statute or under common law, the owner of a reservoir is entitled to release water to the “normal high water line” of a stream without incurring liability for property damaged within the “normal” flood area. However, the definition of the limits within which no liability is imposed vary from place to place and may not be clearly designated on maps. Nonetheless, the right to release water to defined or “historic” floodplain regions downstream from a reservoir can provide substantial relief from strict liability for a reservoir owner.

Statutory modification of the basis of a reservoir owner’s liability, as passed in some states, could have a significant effect. However, as noted above, the trend during the past 25 years has been to widen, not narrow, the scope of negligent behavior by imposing broad expectations of prudence and foresight. Even if standards of “strict liability” are replaced by standards of “negligence,” in the case of a reservoir owner—because the criteria of reasonable care and foresight are broadly interpreted—the change may not greatly affect the actual outcome.

In summary, existing law holds a reservoir owner to the highest standard of care. The owner may be held liable for all damages caused by water escaping from a reservoir—despite the best efforts of the owner and regardless of when downstream development occurred relative to the date of completion.

10.2 Measures to Reduce the Consequences of Dam Failure

You, the owner, can directly and indirectly influence the introduction and use of a variety of measures that will reduce the consequences of dam failure. You should buy insurance, thus pooling your individual risk with others’. Land-use measures, although difficult to institute, can be an even better means of mitigating future disasters. (Restricting people from living in inundation zones obviously will radically improve safety.) Increasing public awareness and better governmental planning also can reduce the consequences of dam failure.

A dam owner can and should obtain insurance directly. The other measures discussed here—land use, public awareness and preparedness planning—are essentially controlled by local governments. Therefore, you would be wise to encourage, as strongly as possible, awareness and action within the public sector. Finally, you may also wish to hire consultants from the private sector when the information needed for prudent decisions exceeds your expertise.

10.2.1 Insurance

In many states a minimum level of insurance coverage is mandated by law; in Texas it is not. In either case, the level of insurance you carry should be based on state law, the value of facilities at risk, potential downstream impacts, the condition and age of the dam, the likelihood of a claim and the cost of available insurance. Because insurance spreads risk among a large group of people, it can not only protect you or your organization, but also your employees and members of governing boards who may be held personally liable. Types of coverage, availability, and cost will vary

from time to time, you would do well to seek professional advice when purchasing insurance. Some insurance companies and brokers specialize in issues related to dam failure. Industry representatives can recommend insurers. A policy can cover not only damage and liability, but also the cost of business interruption, lost income, and workers' compensation.

Insurance should be considered an accepted cost of doing business or enjoying the amenities a dam provides. Many have avoided this cost and have paid severely for their shortsightedness.

10.2.2 Governmental Assistance

A fundamental function of government is to protect citizens from threats to their health, safety, and general welfare. Reducing the consequences of dam failure is clearly a duty of federal, state, and local governments, which have joint and separate responsibilities to the public concerning dam safety.

Land-use planning, public-awareness programs, and emergency-preparedness planning are typically conducted locally, at the level of government most immediately available and responsive to the dam owner (usually the city or county). Federal agencies have technical expertise and can normally supply technical assistance when requested, but ultimately each state is responsible for its own dam-safety program.

Local-government roles—settlement pattern and population growth strongly affect the costs of dam failures. More simply, if no one were allowed to settle in hazardous areas, few, if any, lives would be lost and little property damaged. Conversely, as settlement continues near dams and in inundation zones, the potential for disaster increases commensurately. “Low-hazard” dams are continually being transformed into “significant-hazard” and “high-hazard” dams as this settlement

continues. Increased losses are inevitable unless significant land-use measures are enacted to restrict the use of land in inundation zones. The strategies used will reflect federal, state, and local efforts, but local government must make the critical decisions and only rely on state and federal government for support. All elements of mitigation planning are based on, or affected by, the way in which the affected land is used.

If the land has not been developed, the establishment of open space areas in potential inundation zones is a particularly effective—indeed, the best—way to reduce future costs of dam failure. Nonetheless, few states have organized programs or strategies of land acquisition or settlement restriction, usually because of strong opposition among developers and landowners.

If land is already under development, zoning measures to limit high population density can be useful. Also, the establishment of “green areas”—parks or golf courses—can be low-cost means of limiting settlement in inundation zones. In some fully developed areas, flood-proofing devices (walls, barriers) may prove useful, but must also be maintained.

In much of the nation’s inundation zones, land has already been developed and housing is already in place. People who live in such areas may have a false sense of security, unaware that a hazard even exists.

Experience has clearly shown that simple warning and evacuation procedures can save a significant number of lives. Table 10.1 demonstrates this success and the corresponding failure when early detection and warning are not available. Clearly, communities downstream from a dam should establish a system for early notification and warning.

Awareness varies across the nation. Some people are fully aware of their exposure to this hazard while many do not even realize that they reside in an inundation zone. Obviously, tourists are usually less aware than permanent residents; campgrounds, for example, are not normally posted with signs that point out the existence of a dam hazard. Clearly, awareness is the first step in mitigating the hazard and increasing safety.

Thus, counties, cities, towns and smaller unincorporated communities urgently need:

**Table 10.1
Comparison of Warning Success for
Selected Dam Failures and Flash Floods**

Event	Early Direction & Warning	Potential Loss of Life	Actual Loss of Life	Fatality Rate (%)
Big Thompson, CO. (flash flood)	No	2,500	139	5.6
Laurel Run Dam, PA	No	150	39	25.0
Kelly Barnes Dam, GA	No	200	39	20.0
Buffalo Creek, WV	Some	4,000	125	3.1
Teton Dam, ID	Yes	35,000	11	<0.1
Southern CT 6/82 (20 dams failed)	Yes	Unknown	0	0
Lawn Lake, CO	Yes	4,000	3	<0.1
D.M.A.D., UT	Yes	500	1	0.2
Big Bay Lake Dam, MS	Yes	300	0	0

- to develop programs to increase awareness of existing dam failure hazards, and more specifically, of who is in danger.
- to develop plans for warning and evacuating the population.

- to increase public familiarity with plans through publications, well publicized exercises and other means.

A public-awareness program will usually be well received and generate confidence in government. Media—radio,

television, and newspapers—are potentially the most effective means of educating the public. Encourage public awareness as well as warning and evacuation planning.

Appendix A: Inspection Report

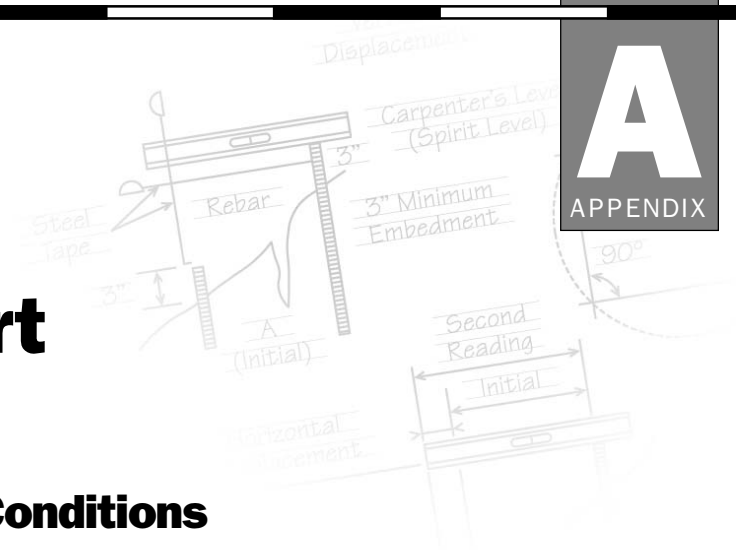

Inspection Results—Dam Conditions

Dam Name: _____ Inventory No: _____

Name of Inspector/s: _____

Name of Contact/s: _____

Date of Inspection: _____ Start Time: _____ End Time: _____ Weather: _____

Crest level (at center) above water: _____

Service spillway level Above or Below water: _____

Emergency spillway level above water: _____

Ground Moisture Condition: Dry Damp Wet Snow ____ Other: _____

Crest of Embankment General Condition: Good Fair Poor Width: _____

Problems Noted: None Rutting Erosion Poor Drainage Height: _____

Trees Depressions Bulges Livestock Damage Cracks Length: _____

Misalignment of Crest Misalignment of Utility Poles Misalignment of Fences or Rails Sinkhole Burrows

Breached Other: _____

Comments: _____

Upstream Embankment General Condition: Good Fair Poor Slope: _____

Problems Noted: None Rip-Rap Erosion Too Steep Burrows Trees Cattails Depressions

Bulges Livestock Damage Slides Concrete Decay Cracks Sinkhole Benching

Misalignment of Rip-rap Open Joints in Concrete

Comments: _____

Downstream Embankment General Condition: Good Fair Poor Slope: _____

Problems Noted: None Sloughing Erosion Too Steep Burrows Trees Cattails Depressions

Bulges Livestock Damage Slides Concrete Decay Cracks Sinkhole Other: _____

Comments: _____

Seepage on Downstream Slope Amount: Major Moderate Minor None Found

Problems Noted: None Saturation Starts at _____ % up Embankment Presence of Sediment in Flow
 Cattails at Toe of Dam Surface Water at Toe of Dam Seepage Associated with Sloughing Continuous Flow
 Sporadic Flow

Comments: _____

Downstream Hazard Conditions Narrow Canyon Wide Canyon Lightly Sloping Prairie Pastureland
 Large Trees and Forest Brushy and Scrubby Forest No Homes Lightly Populated Moderately Populated
 Densely Populated Industrial Businesses Estimated number of homes: _____

Comments: _____

Service Inlet Structure General Condition: Good Fair Poor

Problems Noted: None Blockage Not Located Steel Corrosion Concrete Spalling Concrete Cracking
 Reinforcement Corrosion Missing Parts Timber Decay Leakage Below Water Level Inoperable Valve
 Other: _____

Comments: _____

Service Outlet Structure General Condition: Good Fair Poor

Problems Noted: None Blockage Not Located Corrosion of Conduit Presence of Sediment in Flow
 Inaccessible Concrete Cracking Concrete Spalling Reinforcement Corrosion Misalignment of Walls/Slabs
 Open Joints

Comments: _____

Service Spillway Condition: Good Fair Poor Depth: _____ Width: _____

Problems Noted: None Blockage Not Located Trees Burrows Back-Cutting Erosion Inaccessible
 Livestock Damage Concrete Cracking Concrete Spalling Reinforcement Corrosion Damaged Water-stops
 Open Joints Sinkholes Holes in Spillway Chute Seepage Misalignment of Walls/Slabs Damaged Gates
 Nonfunctional Gates Lubrication of Gates Testing of Gates

Comments: _____

Emergency Spillway Condition: Good Fair Poor Depth: _____ Width: _____

Problems Noted: None Blockage Not Located Trees Burrows Back-Cutting Erosion Inaccessible
 Livestock Damage Concrete Cracking Concrete Spalling Reinforcement Corrosion Damaged Water-stops
 Open Joints Sinkholes Holes in Spillway Chute Seepage Misalignment of Walls/Slabs Damaged Gates
 Nonfunctional Gates Lubrication of Gates Testing of Gates

Comments: _____

Other Items Major road along crest of dam Private road or driveway along crest of dam
 Vehicle bridge along crest of dam Culverts built into crest of dam
 Pipeline immediately downstream from dam - Type of pipeline: _____
 Water supply line in crest of dam Other: _____
Comments: _____

Repair Items Ranked by Priority

Item 1: _____
Item 2: _____
Item 3: _____
Item 4: _____

Security Issues Vehicle Accessible Vehicle Gates Vehicle Fences and Railing Pedestrian Accessible
 Pedestrian Gates and Fences Obscured from Surveillance Locks Breaches in Fence Evidence of Parties
 Graffiti Security System
Comments: _____

Operational Procedures SOP Available Location Kept: _____
 Logbook Location of Logbook: _____
 Major Events Noted Staff Training Topics of Training: _____
 Manual Gate Operations Powered Gate Operations Automated Gate Operations
Comments: _____

Communications Directory Available 24-Hour Coverage Telephone Available at Dam
 Cell Phone Coverage—Provider: _____
Comments: _____

Emergency Action Plan Available Filed with TCEQ Change in Downstream Hazard
Frequency of Update: _____ Date of Last Revision: _____
Date of Last Exercise: _____
Comments: _____

Instrumentation Present Adequately Maintained Inadequately Maintained Operational Data Collected
 Data Analyzed Adequately Protected
Comments: _____

Early Warning System Present Adequately Maintained Inadequately Maintained Operational

Frequency of Maintenance: _____ Date of Last Exercise: _____

Comments: _____

Reservoir Drawdown Capability Method of Drawdown: _____

Maximum Drawdown: _____ c.f.s. Frequency of Testing: _____

Comments: _____

Backup Power Present Adequately Maintained Inadequately Maintained Operational

Frequency of Maintenance: _____ Date of Last Exercise: _____

Comments: _____

Appendix B: Report Forms

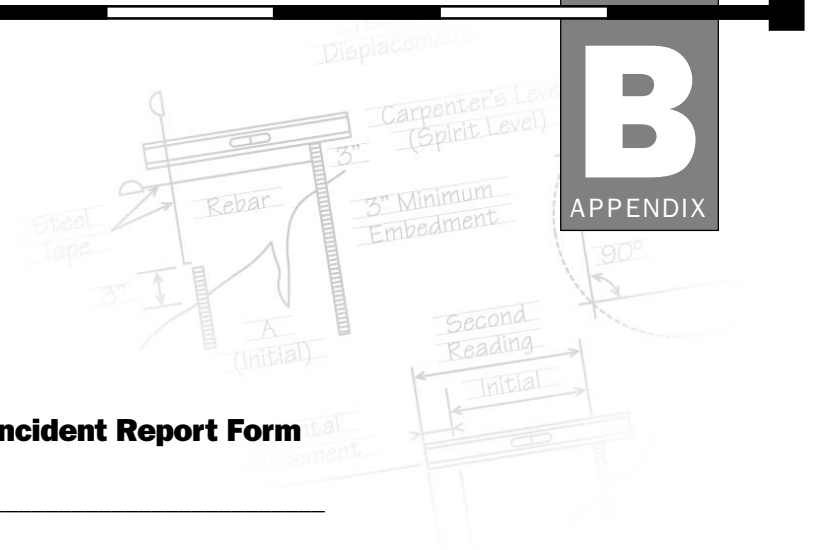

Dam Incident Report Form

Date _____ Time _____

Name of Dam _____

Stream Name _____

Location _____

County _____

Observer _____

Observer Telephone No. _____

Nature of Problem _____

Location of Problem Area (*looking downstream*) _____

Extent of Problem Area _____

Flow Quantity and Color _____

Water Level in Reservoir _____

Was Situation Worsening? _____

Emergency Status _____

Current Weather Conditions _____

Additional Comments _____

Inspection Monitoring Form

Date _____ Time _____

Name of Dam _____

Inspector _____

Item Being Monitored _____

Extent of Area _____

Current Description _____

Change From Previous Inspections _____

Appendix C: Texas Parks and Wildlife's Recommendations on Herbicide Use to Control Vegetation on Earthen Dams

1.01 Herbicide Application Recommendations

Wind direction and speed should be monitored during application of the herbicides to minimize drift into areas of concern. Drift of herbicides into non-target areas is also dependent on the evaporation rate of the pesticide; therefore, TPWD recommends avoiding application of the herbicides during the hottest part of the day, when evaporation is highest. TPWD recommends using the largest droplet size consistent with adequate coverage of the herbicide to further reduce drift. Higher spray volumes typically reduce drift as well.

The application of herbicides on the earthen dams should be delayed if rainfall is expected within 24 hours to further reduce the runoff of herbicides into the adjacent water bodies. The herbicides should be mixed and loaded into the spray units far enough away from the dam locations to ensure that potential spills would not enter the aquatic systems.

When feasible, TPWD recommends utilizing individual plant treatments. The treatment of individual plants would reduce the volume of herbicide required in the control of dam vegetation which could result in lower costs associated with the vegetation management plan. In addition,

adverse impacts to beneficial non-target plant species and aquatic species would be minimized due to the avoidance of exposure and the lower potential for drift and runoff.

Once an earthen dam has been treated with herbicide, TPWD recommends establishing a maintenance plan to reduce the potential for future large scale herbicide applications. The establishment of a mowing and controlled burn schedule could be beneficial to the establishment of native grasses, forbs, and wildflowers on the earthen dams. The promotion of grasses through these methods would reduce the invasion of woody vegetation and reduce the need for additional herbicide applications. Should the use of herbicides be required in the future, applications should be made during the early successional stages so that individual plant treatments would be economically and logistically feasible.

1.02 Threatened and Endangered Species Concerns

According to the Federal Insecticide, Fungicide, and Rodenticide Act, the use of herbicides must comply with the Endangered Species Act. Although the measures proposed in this letter should minimize adverse impacts to fish and wildlife

resources in general, special precautions should be taken to ensure that adverse impacts to rare, threatened, and endangered species are avoided. TPWD has identified four plant species that could potentially be impacted by the herbicidal control of vegetation on dams in Texas.

1.021 Texas Wild-Rice (*Zizania Texana*)

Texas wild-rice is listed as a federally endangered plant species by the U.S. Fish and Wildlife Service (USFWS) and as a state listed endangered species by TPWD. Texas wild-rice is a perennial, emergent, aquatic grass known only from the upper 2.5 km of the San Marcos River in Hays County. Because of the potential sensitivity of Texas wild-rice to herbicide applications and runoff, TPWD recommends avoiding the application of herbicide on earthen dams on the upper 4 km of the San Marcos River and all tributaries that enter the San Marcos River in the upper 4 km of the river.

1.022 Neches River Rose-Mallow (*Hibiscus Dasycalyx*)

The Neches River rose-mallow is listed as a Federal candidate for listing on the threatened and endangered species list by the USFWS. It is also a species of concern for TPWD. The Neches River

rose-mallow is endemic to Texas and grows on wet alluvial soils in swamps or open riparian woodlands. It is possible that the Neches River rose-mallow could grow on earthen dams in Cherokee, Harrison, Houston, and Trinity Counties. TPWD recommends surveying earthen dams to be chemically treated in these counties during the flowering period between June and August to identify rose-mallow populations that would be at risk. Should Neches River rose-mallow populations be identified, TPWD recommends utilizing mechanical means to remove dense vegetation. TPWD recommends maintaining a 100-foot buffer around Neches River rose-mallow populations when spraying herbicides on dams.

1.023 Pecos Sunflower (*Helianthus Paradoxus*)

The Pecos sunflower is listed as a federally threatened species by the USFWS and as a state threatened species by TPWD. The Pecos sunflower is found in moist heavy alkaline/saline calcareous silty clays and loams in and around cienegas (desert springs). It is possible that the Pecos sunflower could grow on or around earthen dams associated with the springs in Pecos and Reeves Counties. TPWD recommends surveying earthen dams to be treated in these counties during the flowering period between September and November to identify Pecos sunflower populations that would be at risk. Should Pecos sunflower populations be identified, TPWD recommends utilizing mechanical means to remove dense vegetation. TPWD recommends maintaining a 100-foot buffer around Pecos sunflower populations when spraying herbicides on dams.

1.024 Little Aguja Pondweed (*Potamogeton Clystocarpus*)

The Little Aguja pondweed is listed as a federally endangered species by the

USFWS and as a state endangered species by TPWD. The Little Aguja pondweed is a submersed aquatic plant known to occur in quiet seepage pools in the Little Aguja Creek drainage in the Davis Mountains. It is also known to occur in the Madera and Cherry Creek drainages. The pondweed fruits between May and October. TPWD recommends utilizing mechanical measures or individual plant treatments on dams upstream from known populations of Little Aguja pondweed, ensuring that the herbicide does not enter the water downstream of the dam.

1.03 Brush Control Herbicides for Use on Dams

The following list of herbicides contains chemicals and formulations known to be effective in the control of vegetation typically found growing on open and previously disturbed habitats, similar to the vegetation associations expected to be growing on dams. These herbicides are also known to have low toxicity to terrestrial and aquatic organisms and are not known to leach into ground and surface waters. The implementation of the recommendations in this letter during the application of the following herbicides in a manner consistent with the herbicide's label should minimize adverse impacts to fish and wildlife resources on and around the dam. The following list of herbicides is certainly not all inclusive as new herbicides are consistently being introduced.

1.031 2,4-D (American Brand 2,4-D, DMA 4 IVM, Weedar 64)

2,4-D (2,4-Dichlorophenoxyacetic acid) was introduced in 1946 and is the most widely used herbicide in the world. Many different manufacturers produce

2,4-D and the list of formulations above are only included to provide examples. 2,4-D is a selective herbicide that is used to control broadleaf herbaceous plants. The salt formulations of 2,4-D are relatively non-toxic to fish and wildlife species. However, the ester formulations of 2,4-D are toxic to fish. Therefore, TPWD recommends avoiding the use of the ester formulations of 2,4-D in the control of vegetation on dams. The 2,4-D salt formulations are used to control box elder (*Acer nugundo*), willow (*Salix spp.*), thistle (*Cirsium spp.*), morning glory (*Ipomoea spp.*), poison ivy (*Toxicodendron radicans*), wild rose (*Rosa spp.*), Virginia creeper (*Parthenocissus quinquefolia*), ragweed (*Ambrosia spp.*), cocklebur (*Xanthium spp.*), Russian thistle (*Salsola kali*), and sunflower (*Helianthus spp.*).

1.032 Glyphosate (Accord, Aquamaster, Glypro, Pondmaster, Rodeo)

Glyphosate is a broad-spectrum, non-selective, systemic herbicide used to control grasses, broadleaf weeds, and woody plants. Because glyphosate is a broad spectrum herbicide, care should be taken during applications to minimize adverse impacts to grasses and native vegetation important for erosion control and stabilization of earthen dams. Glyphosate is used to control dogwood (*Cornus spp.*), maple (*Acer spp.*), oak (*Quercus spp.*), giant reed (*Arundo donax*), salt cedar (*Tamarix spp.*) sweet gum (*Liquidambar styraciflua*), sycamore (*Plantanus occidentalis*), willow, cocklebur, sunflower (*Helianthus spp.*), alligatorweed (*Alternanthera philoxeroides*), cattail (*Typha spp.*) blackberry (*Rubus spp.*), kudzu (*Pueraria lobata*), honeysuckle (*Lonicera spp.*), black locust (*Robinia pseudoacacia*), persimmon (*Diospyros spp.*), wild rose, Russian olive (*Elaeagnus angustifolia*),

Chinese tallow (*Sapium sebiferum*), wax myrtle (*Morella cerifera*), sumac (*Rhus* spp.).

1.033 Imazapyr (Arsenal, Chopper, Habitat, Stalker)

Imazapyr is a broad spectrum, non-selective, systemic herbicide used to control annual and perennial grasses, broadleaf herbaceous plants, woody plants, and riparian and aquatic plants. Because imazapyr is a broad spectrum herbicide, care should be taken during applications to minimize adverse impacts to grasses and native vegetation important for erosion control and stabilization of earthen dams. Imazapyr is used to control giant reed, ragweed, thistle, cocklebur, saltbush (*Atriplex* spp.), greenbriar (*Smilax* spp.), honeysuckle, morning glory, poison ivy, wild rose, kudzu, trumpet creeper (*Campsis radicans*), wild grape (*Vitis* spp.), ash (*Fraxinus* spp.), maple, black locust, box elder, chinaberry (*Melia azedarach*), Chinese tallow, cottonwood (*Populus deltoides*), dogwood, elm (*Ulmus* spp.), hawthorn (*Crataegus* spp.), mulberry (*Morus* spp.), oak, persimmon (*Diospyros* spp.), pine (*Pinus* spp.), privet (*Ligustrum japonicum*), Russian olive, saltcedar, sumac, sweetgum, tree-of-heaven (*Ailanthus altissima*), *Vaccinium* spp., waxmyrtle, willow, and yaupon (*Ilex vomitoria*).

1.034 Fosamine Ammonium (Krenite)

Fosamine ammonium is used to control brush along highway rights-of-way, railroad rights-of-way, industrial sites, storage areas, and utility and pipeline rights-of-way. It is used to control woody species such as oak, pine, sumac, sweetgum, Chinese tallow, elm, wild grape, wild rose, sycamore, and tree-of-heaven. It is also used in combination with metasulfuron methyl (Escort XP) to control eastern red cedar (*Juniperus*

virginiana), tree-of-heaven, ash, elm, and maple. Fosamine ammonium is also used with imazapyr (Arsenal) to control American beautyberry (*Callicarpa americana*), baccharis (*Baccharis neglecta*), *Vaccinium* spp., waxmyrtle, box elder, black locust, dogwood, elm, maple, sassafras (*Sassafras sassafras*) and willow.

1.035 Metsulfuron Methyl (Escort XP)

Escort XP is a selective pre- and post-emergence herbicide used to control broadleaf herbaceous and woody species. It has been used to control cocklebur, blackberry (*Rubus* spp.), thistle, sunflower, honeysuckle, wild rose, ash, black locust, cottonwood, eastern red cedar, elm, hackberry (*Celtis* spp.), hawthorn, mulberry, wild grape, oak, Osage orange, (*Maclura pomifera*), maple, sweetgum, tree-of-heaven, *Vaccinium* spp., and willow.

1.036 Diquat (Reward)

Diquat is a non-selective contact herbicide used to control aquatic and terrestrial vegetation. Although diquat is toxic to aquatic invertebrates, it is approved for aquatic use because it quickly binds to soil and suspended sediments in the water. However, TPWD recommends using care when applying diquat as many water bodies throughout the State support several species of mollusks which are listed as Species of Concern. In addition, diquat can be toxic to many grass species and other vegetation that may be beneficial in the control of dam erosion. Diquat should be applied to minimize impacts to desired, beneficial vegetation.

1.04 Brush Control Herbicides to Avoid on Dams

The following list of herbicides contains chemicals and formulations

known to be effective in the control of upland vegetation in habitats similar to those found on earthen dams. However, because they are known to leach through the soil and accumulate in ground and surface waters or are known to be toxic to aquatic organisms, their use should be avoided in the control of dam vegetation.

1.041 Clopyralid (Reclaim, Stinger, and Transline)

Although clopyralid exhibits a low toxicity to terrestrial and aquatic organisms, it is highly mobile in the soils and can contaminate surface and groundwater which may be used for irrigation and drinking purposes. Because of the proximity of the dams to water, TPWD recommends avoiding the use of clopyralid in the control of vegetation on dams.

1.042 Clopyralid with 2,4-D or MCPA-EHE (Curtail and Curtail M)

Curtail and Curtail M are herbicide formulations which use clopyralid as an active ingredient. Curtail contains clopyralid with 2,4-D while Curtail M contains clopyralid with MCPA-EHE. Because both formulations contain clopyralid, TPWD recommends avoiding the use of Curtail and Curtail M in the control of vegetation on dams.

1.043 Glyphosate

Although glyphosate is practically non-toxic to aquatic organisms, certain surfactants added to some terrestrial formulations of glyphosate have been shown to be highly toxic to aquatic species and amphibians. Non-aquatic formulations of glyphosate (Accord SP, Accord XRT, Glyphomax, Glypro Plus, Honcho, Roundup, Touchdown) should be avoided in the control of vegetation on dams. In addition, other formulations containing

glyphosate combined with 2,4-D or dicamba (Campaign, Fallowmaster, Landmaster II) should be avoided unless labeled for aquatic use.

1.044 Picloram (Tordon 22K, Tordon K)

Although picloram exhibits a low toxicity to terrestrial and aquatic organisms, it is highly mobile in the soils and can contaminate surface and groundwater which may be used for irrigation and drinking purposes. Because of the proximity of the dams to water, TPWD recommends avoiding the use of picloram in the control of vegetation on dams.

1.045 Picloram with 2,4-D (Grazon P+D, Pathway, Tordon RTU, Trodon 101)

Because picloram is extremely mobile in the soil profile and is known to leach

into surface and ground water, TPWD recommends avoiding the use of Grazon P+D, Pathway, Tordon RTU, and Tordon 101 in the control of vegetation on dams.

1.046 Triclopyr (Garlon 3A, Garlon 4, Pathfinder II, Remedy)

Although triclopyr exhibits a low toxicity to terrestrial and aquatic organisms, it is highly mobile in the soils and can contaminate surface and groundwater which may be used for irrigation and drinking purposes. Because of the proximity of the dams to water, TPWD recommends avoiding the use of triclopyr in the control of vegetation on dams.

1.047 Triclopyr with 2,4-D (Crossbow)

Crossbow is toxic to fish and drift or runoff could adversely impact fish and aquatic plants adjacent to the dams. TPWD

recommends avoiding the use of Crossbow in the control of vegetation on dams.

1.048 Triclopyr with Clopyralid (Redeem R&P)

Because triclopyr and clopyralid are extremely mobile in the soil profile and are known to leach into surface and ground water, TPWD recommends avoiding the use of Redeem R&P in the control of vegetation on dams.

Glossary

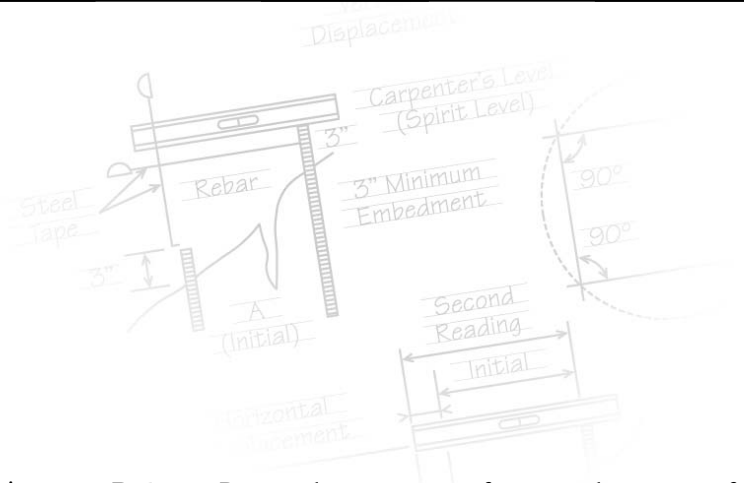

Abutment That part of a valley side against which a dam is constructed. Right and left abutments are those on respective sides of an observer looking downstream.

Air-Vent Pipe A pipe designed to provide air to the outlet conduit to reduce turbulence during release of water. Extra air is usually necessary downstream of constrictions.

Appurtenant Structures Ancillary features of a dam, such as the outlet, spillway, powerhouse, tunnels, etc.

Arch Dam A concrete or masonry dam that is curved so as to transmit the major part of the water pressure to the abutments.

Auxillary Spillway See *spillway*.

Backwater Curve The longitudinal profile of the water surface in an open channel where the depth of flow has been increased by an obstruction, an increase in channel roughness, a decrease in channel width, or a flattening of the bed slope.

Base Width (Base Thickness) The maximum width or thickness of a dam measured horizontally between upstream and downstream faces and normal (perpendicular) to the axis of the dam but excluding projections for outlets, etc.

Berm A horizontal step or bench in the sloping profile of an embankment dam.

Blanket

Drainage Blanket A drainage layer placed directly over the foundation material.

Grout Blanket See *consolidation grouting*.

Upstream Blanket An impervious layer placed on the reservoir floor upstream of a dam. In case of an embankment dam, the blanket may be connected to the impermeable element in a dam.

Butress Dam A dam consisting of a watertight upstream face supported at intervals on the downstream side by a series of buttresses.

Cofferdam A temporary structure enclosing all or part of a construction area so that construction can proceed in a dry area. A *diversion cofferdam* diverts a river into a pipe, channel, or tunnel.

Concrete Lift In concrete work the vertical distance between successive horizontal construction joints.

Conduit A closed channel for conveying discharge through or under a dam.

Consolidation Grouting (Blanket Grouting) The injection of grout to consolidate a layer of the foundation, resulting in greater impermeability, strength, or both.

Construction Joint The interface between two successive placings or pours of concrete where a bond, not permanent separation, is intended.

Core Wall A wall built of impervious material, usually concrete or asphaltic concrete, in the body of an embankment dam to prevent leakage.

Crest Length The length of the top of a dam, including the length of the spillway, powerhouse, navigation lock, fish pass, etc., where these structures form part of the length of a dam. If detached from a dam, these structures should not be included.

Crest of Dam Often used when “top of dam” is meant. To avoid confusion, *crest of spillway* and *top of dam* may be used to refer to the overflow section and the dam proper, respectively.

Culvert (a) A drain or waterway built transversely under a road, railway, or embankment, usually consisting of a pipe or covered channel of box section. (b) A gallery or waterway constructed through any type of dam, which is normally dry but is used occasionally for discharging water, hence the terms *scour culvert*, *drawoff culvert*, and *spillway culvert*.

Cutoff An impervious construction or material which reduces seepage or prevents it from passing through foundation material.

Cutoff Trench An excavation later to be filled with impervious material to form a cutoff. Sometimes used incorrectly to describe the cutoff itself.

Cutoff Wall A wall of impervious material (e.g., concrete, asphaltic concrete, steel-sheet piling) built into the foundation to reduce seepage under the dam.

Dam A barrier built across a watercourse for impounding or diverting the flow of water.

Dead Storage The storage that lies below the invert of the lowest outlet and that, therefore, cannot be withdrawn from the reservoir.

Design Flood See *spillway design flood*.

Diaphragm See *membrane*.

Dike (Levee) A long low embankment whose height is usually less than 5 m and whose length is more than 10 times the maximum height. Usually applied to embankments or structures built to protect land from flooding. If built of concrete or masonry, the structure is usually referred to as a *flood wall*. Also used to describe embankments that block areas on a reservoir rim that are lower than the top of the main dam and that are quite long. In the Mississippi River basin, where the old French word *levee* has survived, the term now applies to flood-protecting embankments whose height can average up to 15 m.

Diversion Channel, Canal, or Tunnel A waterway used to divert water from its natural course. These terms are generally applied to temporary structures such as those designed to bypass water around a dam site during construction. “Channel” is normally used instead of “canal” when the waterway is short. Occasionally these terms are applied to permanent structures.

Drainage Area An area that drains naturally to a particular point on a river.

Drainage Layer or Blanket A layer of permeable material in a dam to relieve pore pressure or to facilitate drainage of fill.

Drainage Wells (Relief Well) A vertical well or borehole, usually downstream of impervious cores, grout curtains, or cutoffs, designed to collect and direct seepage through or under a dam to reduce uplift pressure under or within it. A line of such wells forms a *drainage curtain*.

Drawdown The lowering of water surface level due to release of water from a reservoir.

Earthen Dam or Earthfill Dam See *embankment dam*.

Embankment A slope of fill material, usually earth or rock, that is longer than it is high. The sloping side of a dam.

Embankment Dam (Fill Dam) Any dam constructed of excavated natural materials.

Types of Embankment Dams

Earth Dam (Earthfill Dam) An embankment dam in which more than 50 percent of the total volume is formed of compacted fine-grained material obtained from a borrow area.

Homogeneous Earthfill Dam An embankment dam constructed of similar earth material throughout, except internal drains or drainage blankets; distinguished from a zoned earthfill dam.

Hydraulic Fill Dam An embankment dam constructed of materials, often dredged, that are conveyed and placed by suspension in flowing water.

Rockfill Dam An embankment dam in which more than 50 percent of the total volume comprises compacted or dumped pervious natural or crushed rock.

Rolled Fill Dam An embankment dam of earth or rock in which the material is placed in layers and compacted using rollers or rolling equipment.

Zoned Embankment Dam An embankment dam composed of zones of materials selected for different degrees of porosity, permeability and density.

Emergency Action Plan A predetermined plan of action to be taken to reduce the potential for property damage and loss of lives in an area affected by a dam break.

Emergency Spillway See *spillway*.

Face The external surface of a structure, e.g., the surface of a wall of a dam.

Failure The uncontrolled release of water from a dam.

Filter (Filter Zone) A band or zone of granular material that is incorporated into a dam and is graded (either naturally or by selection) so as to allow seepage to flow across or down the filter without causing the migration of material from zones adjacent to it.

Flashboards A length of timber, concrete, or steel placed on the crest of a spillway to raise the retention water level but that may be quickly removed in the event of a flood, either by a tripping device or by deliberately designed failure of the flashboard or its supports.

Floodplain An area adjoining a body of water or natural stream that has been, or may be, covered by flood water.

Floodplain Management A management program to reduce the consequences of flooding—either by natural runoff or by dam failure—to existing and future properties in a floodplain.

Flood Routing The determination of the attenuating effect of storage on a flood passing through a valley, channel, or reservoir.

Flood Surge The volume or space in a reservoir between the controlled retention water level and the maximum water level. Flood surge cannot be retained in the reservoir but will flow over the spillway until the controlled retention water level is reached.

Flood Wall A concrete wall constructed adjacent to a stream to prevent flooding of property on the landward side of the wall, normally constructed in lieu of or to supplement a levee where the land required for levee construction is expensive or not available.

Foundation of Dam The natural material on which the dam structure is placed.

Freeboard The vertical distance between a stated water level and the top of a dam. *Net freeboard*, *dry freeboard*, *flood freeboard*, or *residual freeboard* is the vertical distance between the estimated maximum water level and the top of a dam. *Gross freeboard* or *total freeboard* is the vertical distance between the maximum planned controlled retention water level and the top of a dam.

Gallery (a) A passageway within the body of a dam or abutment, hence the terms *grouting gallery*, *inspection gallery*, and *drainage gallery*. (b) A long and rather narrow hall, hence the following terms for a power plant: *valve gallery*, *transformer gallery*, and *busbar gallery*.

Gate A device in which a leaf or member is moved across the waterway from an external position to control or stop the flow.

Bulkhead Gate A gate used either for temporary closure of a channel or conduit to empty it for inspection or maintenance or for closure against flowing water when the head difference is small, e.g., for diversion tunnel closure. Although a bulkhead gate is usually opened and closed under nearly balanced pressures, it nevertheless may be capable of withstanding a high pressure differential when in the closed position.

Crest Gate (Spillway Gate) A gate on the crest of a spillway to control overflow or reservoir water level.

Emergency Gate A standby or reserve gate used only when the normal means of water control is not available.

Fixed Wheel Gate (Fixed-Roller Gate, Fixed-Axle Gate) A gate having wheels or rollers mounted on the end posts of the gate. The wheels bear against rails fixed in side grooves or gate guides.

Flap Gate A gate hinged along one edge, usually either the top or bottom edge. Examples of bottom-hinged flap gates are tilting gates and *belly gates*, so called due to their shape in cross-section.

Flood Gate A gate to control flood release from a reservoir.

Guard Gate (Guard Valve) A gate or valve that operates fully open or closed. It may function as a secondary device for shutting off the flow of water in case the primary closure device becomes inoperable, but is usually operated under conditions of balanced pressure and no flow.

Outlet Gate A gate controlling the outflow of water from a reservoir.

Radial Gate (Tainter Gate) A gate with a curved upstream plate and radial arms hinged to piers or other supporting structures.

Regulating Gate (Regulating Valve) A gate or valve that operates under full pressure and flow to throttle and vary the rate of discharge.

Slide Gate (Sluice Gate) A gate that can be opened or closed by sliding it in supporting guides.

Gravity Dam A dam constructed of concrete, masonry, or both that relies on its weight for stability.

Grout Cap A concrete pad or wall constructed to facilitate pressure grouting of the grout curtain beneath it.

Grout Curtain (*Grout Cutoff*) A barrier produced by injecting grout into a vertical zone, usually narrow horizontally, in the foundation to reduce seepage under a dam.

Height Above Lowest Foundation The maximum height from the lowest point of the general foundation to the top of the dam.

Hydraulic Height The height to which water rises behind a dam and the difference between the lowest point in the original streambed at the axis of the dam and the maximum controllable water surface.

Hydrograph A graphic representation of discharge, stage, or other hydraulic property with respect to time for a particular point on a stream. (At times the term is applied to the phenomenon the graphic representation describes; hence a flood hydrograph is the passage of a flood discharge past the observation point.)

Inclinometer An instrument, usually consisting of a metal or plastic tube inserted in a drill hole and a sensitized monitor either lowered into the tube or fixed within it. The monitor measures at different points the tube's inclination to the vertical. By integration, the lateral position at different levels of the tube may be found relative to a point, usually the top or bottom of the tube, assumed to be fixed. The system may be used to measure settlement.

Intake Any structure in a reservoir, dam, or river through which water can be drawn into an aqueduct.

Internal Erosion See *piping*.

Inundation Map A map delineating the area that would be inundated in the event of a failure.

Leakage Uncontrolled loss of water by flow through a hole or crack.

Lining With reference to a canal, tunnel, shaft, or reservoir, a coating of asphaltic concrete, reinforced or unreinforced concrete, shotcrete, rubber or plastic to provide water tightness, prevent erosion, reduce friction, or support the periphery of structure. May also refer to lining, such as steel or concrete, of outlet pipe or conduit.

Low-Level Outlet (*Bottom Outlet*) An opening at a low level from a reservoir generally used for emptying or for scouring sediment and sometimes for irrigation releases.

Masonry Dam A dam constructed mainly of stone, brick, or concrete blocks that may or may not be joined with mortar. A dam having only a masonry facing should not be referred to as a masonry dam.

Maximum Cross-Section of Dam A cross-section of a dam at the point of its maximum height.

Maximum Water Level The maximum water level, including flood surcharge, the dam is designed to withstand.

Membrane (*Diaphragm*) A sheet or thin zone or facing made of a flexible material, sometimes referred to as a *diaphragm wall* or *diaphragm*.

Minimum Operating Level The lowest level to which the reservoir is drawn down under normal operating conditions.

Morning Glory Spillway See *spillway*.

Normal Water Level For a reservoir with a fixed overflow sill the lowest crest level of that sill. For a reservoir whose outflow is controlled wholly or partly by movable gates, siphons or other means, it is the maximum level to which water may rise under normal operating conditions, exclusive of any provision for flood surcharge.

One-Hundred Year (100-Year) Exceedance Interval The flood magnitude expected to be equaled or exceeded on the average of once in 100 years. It may also be expressed as an *exceedance frequency*, i.e. a percent chance of being exceeded in any given year.

Outlet An opening through which water can be freely discharged from a reservoir.

Overflow Dam A dam designed to be overtopped.

Parapet Wall A solid wall built along the top of a dam for ornament, for the safety of vehicles and pedestrians, or to prevent overtopping.

Peak Flow The maximum instantaneous discharge that occurs during a flood. It coincides with the peak of a flood hydrograph.

Pervious Zone A part of the cross-section of an embankment dam comprising material of high permeability.

Phreatic Surface The free surface of groundwater at atmospheric pressure.

Piezometer An instrument for measuring pore water pressure within soil, rock, or concrete.

Piping The progressive development of internal erosion by seepage, appearing downstream as a hole or seam discharging water that contains soil particles.

Pore Pressure The interstitial pressure of water within a mass of soil, rock, or concrete.

Pressure Cell An instrument for measuring pressure within a mass of soil, rock, or concrete or at an interface between one and the other.

Pressure Relief Pipes Pipes used to relieve uplift or pore water pressure in a dam's foundation or structure.

Probable Maximum Flood (PMF) A flood that would result from the most severe combination of critical meteorologic and hydrologic conditions possible in the region.

Probable Maximum Precipitation (PMP) The maximum amount and duration of precipitation that can be expected to occur on a drainage basin.

Pumped Storage Reservoir A reservoir filled entirely or mainly with water pumped from outside its natural drainage area.

Regulating Dam A dam impounding a reservoir from which water is released to regulate the flow in a river.

Relief Well See *drainage well*.

Reservoir Area The surface area of a reservoir when filled to controlled retention level.

Reservoir Routing The computation by which the interrelated effects of the inflow hydrograph, reservoir storage, and discharge from the reservoir are evaluated.

Reservoir Surface The surface of a reservoir at any level.

Riprap A layer of large stones, broken rock, or precast blocks placed randomly on the upstream slope of an embankment dam, on a reservoir shore, or on the sides of a channel as a protection against wave action. Very large riprap is sometimes referred to as armoring.

Risk Assessment As applied to dam safety, the process of identifying the likelihood and consequences of dam failure to provide the basis for informed decisions on a course of action.

Rockfill Dam See *embankment dam*.

Rollcrete or Roller-Compacted Concrete A no-slump concrete that can be hauled in dump trucks, spread with a bulldozer or grader, and compacted with a vibratory roller.

Seepage The interstitial movement of water that may take place through a dam, its foundation, or its abutments.

Sill (a) A submerged structure across a river to control the water level upstream. (b) The crest of a spillway. (c) A horizontal gate seating, made of wood, stone, concrete or metal at the invert of any opening or gap in a structure, hence the expressions *gate sill* and *stoplog sill*.

Slope (a) The side of a hill or mountain. (b) The inclined face of a cutting or canal or embankment. (c) Inclination from the horizontal. In the United States, it is measured as the ratio of the number of units of horizontal distance to the number of corresponding units of vertical distance. The term is used in English for any inclination and is expressed as a percentage when the slope is gentle, in which case the term *gradient* is also used.

Slope Protection The protection of a slope against wave action or erosion.

Sluiceway See *low-level outlet*.

Spillway A structure over or through which flood flows are discharged. If the flow is controlled by gates, it is a controlled spillway; if the elevation of the spillway crest is the only control, it is an uncontrolled spillway.

Auxiliary Spillway (Emergency Spillway) A secondary spillway designed to operate only during exceptionally large floods.

Fuse-Plug Spillway An auxiliary or emergency spillway comprising a low embankment or a natural saddle designed

to be overtopped and eroded away during a very rare and exceptionally large flood.

Primary Spillway (Principal Spillway) The principal or first-used spillway during flood flows.

Shaft Spillway (Morning Glory Spillway) A vertical or inclined shaft into which flood water spills and then is conducted through, under, or around a dam by means of a conduit or tunnel. If the upper part of the shaft is splayed out and terminates in a circular horizontal weir, it is termed a “bellmouth” or “morning glory” spillway.

Side Channel Spillway A spillway whose crest is roughly parallel to the channel immediately downstream of the spillway.

Siphon Spillway A spillway with one or more siphons built at crest level. This type of spillway is sometimes used for providing automatic surface-level regulation within narrow limits or when considerable discharge capacity is necessary within a short period of time.

Spillway Channel (Spillway Tunnel) A channel or tunnel conveying water from the spillway to the river downstream.

Spillway Design Flood (SDF) The largest flood that a given project is designed to pass safely. The reservoir inflow-discharge hydrograph used to estimate the spillway discharge capacity requirements and corresponding maximum surcharge elevation in reservoir.

Stilling Basin A basin constructed to dissipate the energy of fast-flowing water, e.g., from a spillway or bottom outlet, and to protect the riverbed from erosion.

Stoplogs Large logs or timber or steel beams placed on top of each other with their ends held in guides on each side of a channel or conduit providing a cheaper or easily handled temporary closure than a bulkhead gate.

Storage The retention of water or delay of runoff either by planned operation, as in a reservoir, or by temporary filling of overflow areas, as in the progression of a flood crest through a natural stream channel.

Tailrace The tunnel, channel or conduit that conveys the discharge from the turbine to the river, hence the terms *tailrace tunnel* and *tailrace canal*.

Tailwater Level The level of water in the tailrace at the nearest free surface to the turbine or in the discharge channel immediately downstream of the dam.

Toe of Dam The junction of the downstream face of a dam with the ground surface, referred to as the *downstream toe*. For an embankment dam the junction of upstream face with ground surface is called the *upstream toe*.

Top of Dam The elevation of the uppermost surface of a dam, usually a road or walkway, excluding any parapet wall, railings, etc.

Top Thickness (Top Width) The thickness or width of a dam at the level of the top of the dam. In general, “thickness” is used for gravity and arch dams, “width” for other dams.

Transition Zone (Semipervious Zone) A part of the cross-section of a zoned embankment dam comprising material of intermediate size between that of an impervious zone and that of a permeable zone.

Trashrack A screen located at an intake to prevent the ingress of debris.

Tunnel A long underground excavation usually having a uniform cross-section. Types of tunnel include: *headrace tunnel*, *pressure tunnel*, *collecting tunnel*, *diversion tunnel*, *power tunnel*, *tailrace tunnel*, *navigation tunnel*, *access tunnel*, *scour tunnel*, *drawoff tunnel*, and *spillway tunnel*.

Underseepage The interstitial movement of water through a foundation.

Uplift The upward pressure in the pores of a material (interstitial pressure) or on the base of a structure.

Upstream Blanket See *blanket*.

Valve A device fitted to a pipeline or orifice in which the closure member is either rotated or moved transversely or longitudinally in the waterway so as to control or stop the flow.

Waterstop A strip of metal, rubber or other material used to prevent leakage through joints between adjacent sections of concrete.

Weir (a) A low dam or wall built across a stream to raise the upstream water level, called *fixed-crest weir* when uncontrolled. (b) A structure built across a stream or channel for measuring flow, sometimes called a *measuring weir* or gauging weir. Types of weir include *broad-crested weir*, *sharp-crested weir*, *drowned weir*, and *submerged weir*.

Selected Bibliography

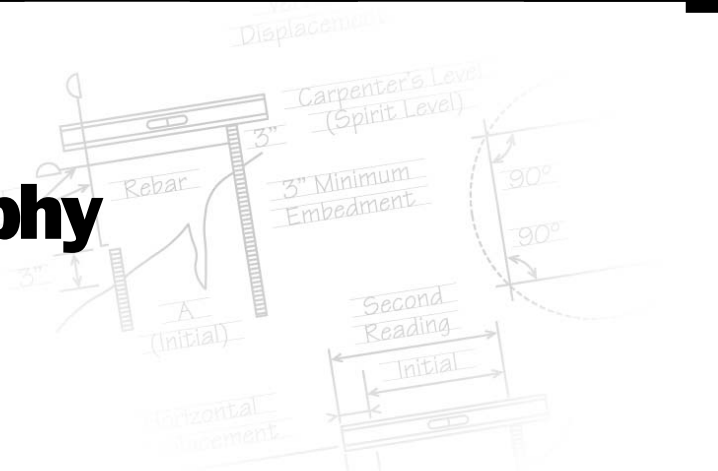

State Manuals

Arkansas Soil and Water Conservation Commission. 2002. *Inspection and Maintenance Manual for Arkansas Dam Owners*. Little Rock.

Colorado State Engineer's Office, Division of Water Resources. 2002. *Dam Safety Manual*. Denver.

Georgia Department of Natural Resources, Environmental Protection Division. 1988. *Operation, Maintenance and Inspection Procedures for Earthfill Dams*. Atlanta.

Illinois Department of Natural Resources. 1999. *Guidelines and Forms for Inspection of Illinois Dams*. Springfield.

Indiana Department of Natural Resources, Division of Water. 2001. *General Guidelines for New Dams and Improvements to Existing Dams in Indiana*. Indianapolis.

Kentucky Natural Resources and Environmental Protection Cabinet, Division of Water. 1985. *Guidelines for Maintenance and Inspection of Dams in Kentucky*. Frankfort.

Missouri Department of Natural Resources, Division of Geology and Land Survey. 1991. *Maintenance, Inspection, and Operation of Dams in Missouri*. Rolla.

New Mexico State Engineer Office. 1989. *A Dam Owner's Guidance Manual*. Santa Fe.

North Carolina Department of Environmental and Natural Resources, Division of Land Resources, Land Quality Security. 1989. *Dam Operation, Maintenance and Inspection Manual*. Raleigh.

North Dakota Division of the State Engineer. 1985. *North Dakota Dam Design Handbook*, 1985. Bismarck.

Ohio Department of Natural Resources, Division of Water. 1987. *Suggested Procedures for Safety Inspection of Dams*. Columbus.

Pennsylvania Department of Environmental Resources, Division of Dam Safety. 1999. *The Inspection, Maintenance and Operation of Dams in Pennsylvania*. Harrisburg.

Washington State, Department of Ecology, *Dam Safety Guidelines*, 1992, Olympia.

General Bibliography

American Society of Civil Engineers / U.S. Commission on Large Dams. 1975. *Lessons from Dam Incidents, USA*. New York: ASCE.

———. 1993. Loren Anderson, ed. *Geotechnical Practices in Dam Rehabilitation*. Proceedings, Specialty Conference, Raleigh, NC.

Bomar, George W. 1983. *Texas Weather*. Austin: University of Texas Press.

Brater, E. F., and H.W. King. 1996. *Handbook of Hydraulics for the Solution of Hydraulic Engineering Problems*. 7th ed. New York: McGraw-Hill.

Casagrande, Arthur, Ronald C. Hirschfield, and George E. Bertram. 1973. *Embankment Dam Engineering: Casagrande Volume*. New York: John Wiley.

Cedergren, Harry R. 1997. *Seepage, Drainage, and Flownets*. 3rd ed. New York: John Wiley and Sons.

Chow, Ven Te. 1959. *Open Channel Hydraulics*. New York: McGraw-Hill.

Dam Removal: Science and Decision Making. 2002. Washington: H. John Heinz III Center for Science, Economics and the Environment.

Dunnicliff, John. 1993. *Geotechnical Instrumentation for Monitoring Field Performance*. New York: John Wiley and Sons.

Federal Emergency Management Agency (FEMA). 2003. *Federal Guidelines for Dam Safety: Glossary of Terms (FEMA 148)*. Jessup, MD.

- . 2004a. *Federal Guidelines for Dam Safety: Emergency Action Planning for Dam Owners* (FEMA 64). Jessup, MD.
- . 2004b.—*Federal Guidelines for Dam Safety* (FEMA 93). Jessup, MD.
- . 2004c.—*Federal Guidelines for Dam Safety: Selecting and Accommodating Inflow Design Floods for Dams*—(FEMA 94). Jessup, MD.
- . 2004d.—*Federal Guidelines for Dam Safety: Hazard Potential Classification System for Dams* (FEMA 333). Jessup, MD.
- . Dam Owner's Guide to Animal Impacts on Earthen Dams (FEMA L-264). 2005a. Jessup, MD.
- . 2005b.—*Technical Manual: Conduits through Embankment Dams: Best Practices for Design, Construction, Identification and Evaluation, Inspection, Maintenance, Renovation, and Repair* (FEMA L-266 or FEMA 484DVD). Jessup, MD.
- . 2005c.—*Technical Manual for Dam Owners: Impacts of Animals on Earthen Dams* (FEMA 473). Jessup, MD.
- . 2005d.—*Technical Manual for Dam Owners: Impacts of Plants on Earthen Dams* (FEMA 534). Jessup, MD.
- Golze, A. R., ed. 1977. *Handbook of Dam Engineering*. New York: Van Nostrand Reinhold. Graham, Wayne J. 1983. *Dam Failure Warning Effectiveness*. Denver: U.S. Bureau of Reclamation. Unpublished report.
- . 1997. *A Procedure for Estimating Loss of Life Due to Dam Failure*. Annual Conference Proceedings, ASDSO. 629–40.
- . 2004. *A Method for Easily Estimating the Loss of Life from Dam Failure*. Denver: U.S. Bureau of Reclamation. Unpublished report.
- Jansen, R. B. 1980. *Dams and Public Safety*. Denver: U.S. Bureau of Reclamation.
- McCook, Danny. 1997. *Chimney Filters—Design and Construction Considerations*. ASDSO Annual Conference Proceedings, Pittsburgh. 29–38.
- . 2004. *A Comprehensive Discussion of Piping and Internal Erosion Failure Mechanisms*. CD-ROM. ASDSO Annual Conference Proceedings, Phoenix.
- . 2006. *A Discussion of Uplift Computations for Embankments and Levees*. ASDSO West Regional Conference, Overland Park, KS.
- and James Talbot. 1995.—*NRCS Filter Design Criteria: A Step by Step Approach*. ASDSO Annual Conference Proceedings, Atlanta. 49–58.
- National Research Council. 1982a. *Geotechnical Instrumentation for Monitoring Field Performance*. Washington: National Academy Press.
- . 1982b.—*Safety of Non-Federal Dams: A Review of the Federal Role*. Washington: National Academy Press.
- . *Safety of Existing Dams, Evaluation and Improvement*, 1983. Washington: National Academy Press.
- . 1985. *Safety of Dams Flood and Earthquake Criteria*. Washington: National Academy Press.
- . 1988. *Estimating Probabilities of Extreme Floods, Methods and Recommended Research*. Washington: National Academy Press.
- Portland Cement Association. 2002. *Design Manual for RCC Spillways and Overtopping Protection*. Skokie, IL: Portland Cement Association.
- . 2003. *Design Manual for Small RCC Dams*. Skokie, IL: Portland Cement Association.
- Sherard, James L., et al. 1963. *Earth and Earth-Rock Dams: Engineering Problems of Design and Construction*. New York: John Wiley and Sons.
- Terzaghi, Karl, Ralph Peck, and Gholamaeza Mesri. 1996. *Soil Mechanics and Engineering Practices*. New York: John Wiley and Sons.
- Thompson, Stephen A., and Gilbert F. White. 1985. "A National Floodplain Map." *Journal of Soil and Water Conservation* 40(5): 417–19.
- U.S. Army Corps of Engineers. 1985. *Earthquake Analysis and Design of Concrete Gravity Dams*. TL 1110-2-203. Washington.
- . 1986. *Seepage Analysis and Control of Dams*, EM 1110-2-1901. Washington.
- . 1995. *Construction Control for Earth and Rock-Fill Dams*, EM 1110-2-1911. Washington.
- . 2000. *Roller-Compacted Concrete*, EM 1110-2-2006. 2000. Washington.
- . 2004. *General Design and Construction for Earth and Rock-Fill Dams*, EM 1110-2-2300. Washington.
- U.S. Bureau of Reclamation. 1974. *Earth Manual*. 2nd ed. Denver.

- . 1981. *Concrete Manual*. Denver.
- . 1983. *Dam Safety Hazard Classification Guidelines*. Denver.
- . 1986. *Guidelines to Decision Analysis*. ACER Technical Memorandum 7. Denver.
- . 1987. *Design of Small Dams*. 3rd ed. Denver.
- . 1988. *Training Aids For Dam Safety*. Denver.
- . 1995a.—*Design of Arch Dams*. Denver.
- . 1995b.—*Design of Gravity Dams*. Denver.
- . 1995c.—*Embankment Dams Instrumentation Manual*. Denver.
- . 2003. *Guidelines for Achieving Public Protection in Dam Safety Decisionmaking*. Denver.
- . 2005. *Safety Evaluation of Existing Dams (SEED Manual)*. Washington: U.S. GPO.
- U.S. Department of Agriculture, Natural Resources Conservation Service. 2004. *National Engineering Handbook 4*. Washington.
- U.S. Geological Survey. 2003. *Major and Catastrophic Storms and Floods in Texas*. Open file report 03-193. Denver.

U.S. Society of Dams. 2002. *General Guidelines for Automated Performance Monitoring of Dams*. Denver.

Viessman, Warren Jr., and Gary L. Lewis. 2003. *Introduction to Hydrology*. 5th ed. New York: Prentice Hall.

Online

Association of State Dam Safety Officials (ASDSO). <www.damsafety.org>

Federal Emergency Management Agency (FEMA). <www.fema.gov/plan/prevent/damfailure/>

National Performance of Dams. <npdp.stanford.edu>

Portland Cement Association. <www.cement.org/>

U.S. Army Corps of Engineers. <www.usace.army.mil/publications/eng-manuals/em.htm>

U.S. Department of Agriculture, Natural Resources Conservation Service. <www.info.usda.gov/CED/>

U.S. Bureau of Reclamation. <www.usbr.gov/>

U.S. Society of Dams. <www.usdams.org>



 printed on recycled paper using soy based ink

GI-357

11/06

The TCEQ is an equal opportunity/affirmative action employer. The agency does not allow discrimination on the basis of race, color, religion, national origin, sex, disability, age, sexual orientation or veteran status. In compliance with the Americans with Disabilities Act, this document may be requested in alternate formats by contacting the TCEQ at 512/239-0028, Fax 239-4488, or 1-800-RELAY-TX (TDD), or by writing P.O. Box 13087, Austin, TX 78711-3087.

