

# 1 Temporary Best Management Practices

## *1.1 Introduction*

The two most basic categories of temporary control methods for construction-generated pollution are erosion and sediment controls. Erosion controls are used to prevent soil on the construction site from being mobilized and transported by stormwater runoff. Vegetative stabilization, slope coverings, and diversion of runoff away from exposed areas can effectively prevent erosion. Sediment controls may be considered as the second line of defense and include sedimentation ponds, silt fences, berms and other temporary barriers that temporarily detain the runoff. Runoff velocities are reduced in these controls allowing sediment in the runoff to settle out.

This chapter gives instructions for installation of the most commonly used erosion and sediment control practices. Each practice is presented with a list of guidelines for proper installation and a compilation of common trouble points. Additional information on these and other practices can be found in other manuals.

Contractors are encouraged to install and maintain practices carefully, in a professional manner. Minor adjustments should be anticipated to assure proper performance. Intensive maintenance and extensive use of vegetation, mulch, and other ground covers may be required to achieve optimum performance. We recommend very strongly, therefore, that such erosion and sediment control efforts be specified clearly in the general construction contract and that any unexpected expenses be approved before they are incurred. When these controls are removed after final stabilization of the site, it is important to also remove or stabilize any accumulated sediment.

Periodic inspection and maintenance is vital to the performance of erosion and sedimentation control measures. It is recommended that all temporary erosion controls be inspected weekly and after every rainfall; however, daily inspections may be warranted when environmentally sensitive features are located on or immediately adjacent to the site. If not properly maintained, some practices may cause more damage than they prevent.

Always evaluate the consequences of a measure failing when considering which control measure to use, since failure of a practice may be hazardous or damaging to both people and property. For example, a large sediment basin failure can have disastrous results; low points in dikes can cause major gullies to form on a fill slope. It is essential to inspect all practices to determine that they are working properly and to ensure that problems are corrected as soon as they develop. Assign an individual responsibility for routine checks of operating erosion and sedimentation control practices.

## 1.2 General Guidelines

The following planning and construction practices were described by the U.S. Environmental Protection Agency (EPA, 1993) and North Carolina (North Carolina, 1993) to illustrate the types of measures that can be applied successfully to achieve a reduction in the amount of erosion occurring on active construction sites. These practices are used to reduce the amount of sediment that is detached during construction and to prevent sediment from entering runoff. Erosion control is based on two main concepts: (1) disturb the smallest area of land possible for the shortest period of time, and (2) stabilize disturbed soils to prevent erosion from occurring.

### *Development Siting*

Review and consider all existing conditions in the initial site selection for the project. Select a site that is suitable rather than force the terrain to conform to development needs (Figure 1-1). Ensure that development features follow natural contours. Steep slopes, areas subject to flooding, and highly erodible soils severely limit a site's use, while level, well-drained areas offer few restrictions. Any modification of a site's drainage features or topography requires protection from erosion and sedimentation.

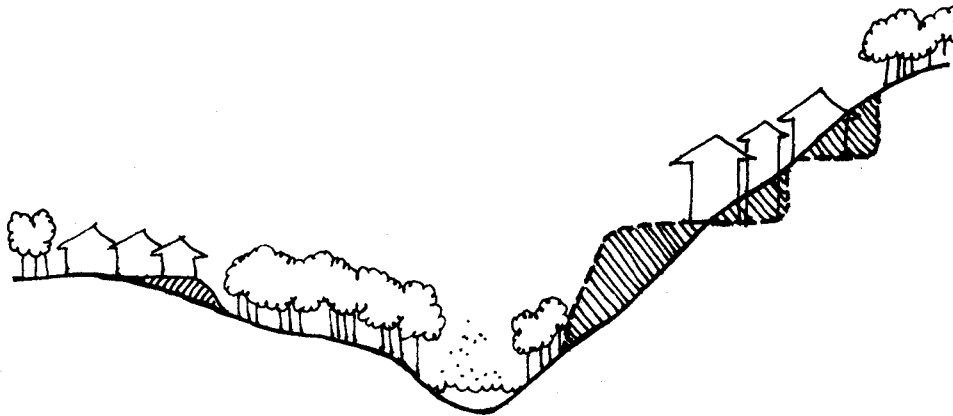

**Figure 1-1 Examples of Proper and Improper Siting (North Carolina, 1993)**

### *Project Scheduling*

Often a project can be scheduled during the time of year that the erosion potential of the site is relatively low. In many parts of the country, there is a certain period of the year when erosion potential is relatively low and construction scheduling could be very

effective. In central Texas, rainfall amounts are generally lower during July and August and the hot temperatures quickly dry out exposed soils. During the wetter months (spring and fall), construction vehicles can easily turn the soft, wet ground into mud, which is more easily washed offsite.

Scheduling can be a very effective means of reducing the hazards of erosion. Schedule construction activities to minimize the exposed area and the duration of exposure. In scheduling, take into account the season and the weather forecast. Stabilize disturbed areas as quickly as possible.

Avoid area wide clearance of construction sites. Plan and stage land disturbance activities so that only the area currently under construction is exposed. As soon as the grading and construction in an area are complete, the area should be stabilized.

### *Material Management*

Locate potential nonpoint pollutant sources away from steep slopes, streams, and critical areas. Material stockpiles, borrow areas, access roads, and other land-disturbing activities can often be located away from critical areas such as steep slopes, highly erodible soils, and areas that drain directly into geologically sensitive features. The exposure of litter, construction debris, and chemicals to stormwater should be minimized to prevent them from becoming a pollutant source. Daily litter removal and screening outfalls and storm drain inlets may help retain these materials onsite.

Stockpile topsoil and reapply to revegetate site. Because of the high organic content of topsoil, it cannot be used as fill material or under pavement. Topsoil is typically removed when a site is cleared. Since topsoil is essential to establish new vegetation, it should be stockpiled and then reapplied to the site for revegetation, if appropriate. Although topsoil salvaged from the existing site can often be used, it must meet certain standards and topsoil may need to be imported onto the site if the existing topsoil is not adequate for establishing new vegetation.

Cover or stabilize topsoil stockpiles. Unprotected stockpiles are very prone to erosion and therefore stockpiles must be protected. Small stockpiles can be covered with a tarp to prevent erosion. Large stockpiles should be stabilized with erosion blankets, seeding, and/or mulching. In addition, spoils should not be stored within the 100-year floodplain where they can be disturbed during high flow conditions.

### *Vegetation Protection*

By clearing only those areas immediately essential for completing site construction, buffer zones are preserved and soil remains undisturbed until construction begins (Figure 1-2). Physical markers, such as tape, signs, or barriers, indicating the limits of land disturbance, can ensure that equipment operators know the proposed limits of clearing.

The area of the watershed that is exposed to construction is important in determining the net amount of erosion. Reducing the extent of the disturbed area will ultimately reduce sediment loads to surface waters. Existing or newly planted vegetation that has been planted to stabilize disturbed areas should be protected by routing construction traffic around the areas and protecting natural vegetation with fencing, tree armoring, retaining walls, or tree wells. Avoid disturbing vegetation on steep slopes or other critical areas.

Where possible, construction traffic should travel over areas that must be disturbed for other construction activity. This practice will reduce the area that is cleared and susceptible to erosion.

Tree armoring protects tree trunks from being damaged by construction equipment. Fencing can also protect tree trunks, but should be placed at the tree's drip line so that construction equipment is kept away from the tree. The tree drip line is the minimum area around a tree in which the tree's root system should not be disturbed by cut, fill, or soil compaction caused by heavy equipment. When cutting or filling must be done near a tree, a retaining wall or tree well should be used to minimize the cutting of the tree's roots or the quantity of fill placed over the roots.

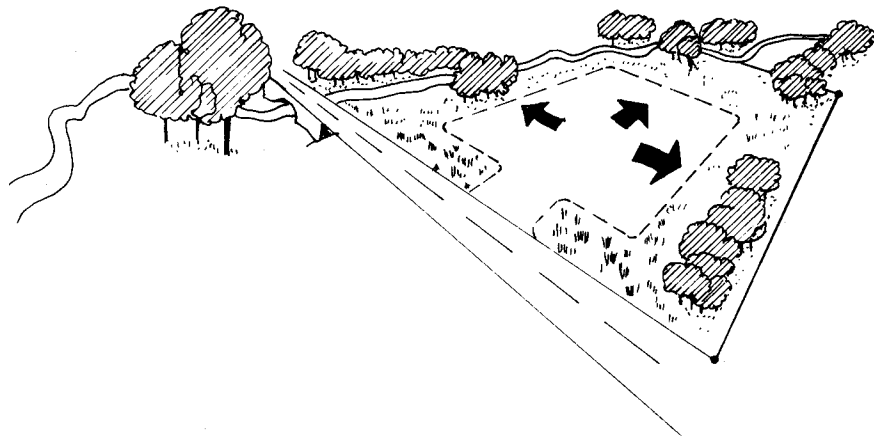

**Figure 1-2 Example of Conservative Site Clearing (North Carolina, 1993)**

*Use wind erosion controls.*

Although not required by the rules, wind erosion controls can reduce the impact of construction on adjacent tracts. These controls limit the movement of dust from disturbed soil surfaces and include many different practices. Wind barriers block air currents and are effective in controlling soil blowing. Many different materials can be used as wind barriers, including solid board fences, snow fences, and bales of hay. Sprinkling moistens the soil surface with water and must be repeated as needed to be effective for preventing wind erosion; however, applications must be monitored to prevent excessive runoff and erosion.

### *Protect Area from Upgradient runoff*

Protect areas to be disturbed from stormwater runoff. Use dikes, diversions, and waterways to interrupt runoff and divert it away from cut-and-fill slopes or other disturbed areas. To reduce on-site erosion, install these measures before clearing and grading.

Earth dikes, perimeter dikes or swales, or diversions can be used to intercept and convey runoff above disturbed areas (Figure 1-3). An earth dike is a temporary berm or ridge of compacted soil that channels water around or away from disturbed areas. A perimeter dike/swale or diversion is a swale with a supporting ridge on the lower side that is constructed from the soil excavated from the adjoining swale. These practices should be used to intercept flow from denuded areas or newly seeded areas to keep the disturbed areas from being eroded from the uphill runoff. The structures should be stabilized within 14 days of installation or as soon as practicable with vegetation, slope coverings or other appropriate erosion prevention measures. A pipe slope drain, also known as a pipe drop structure, is a temporary pipe placed from the top of a slope to the bottom of the slope to convey concentrated runoff down the slope without causing erosion.

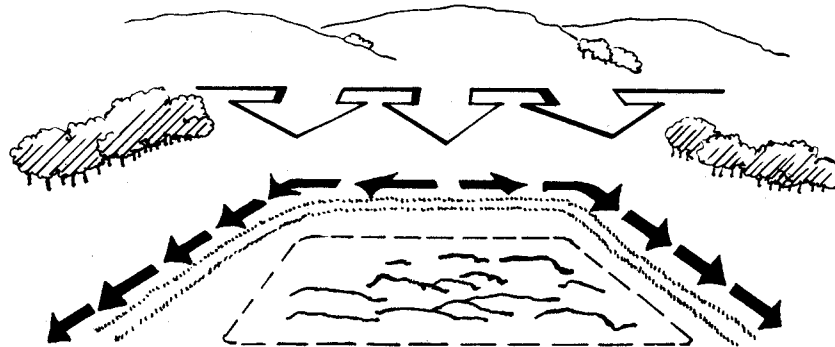

**Figure 1-3 Diversion of Runoff away from Construction Area (North Carolina, 1993)**

### *Reduce Runoff Velocities*

Keep runoff velocities low. Clearing existing vegetation reduces the surface roughness and infiltration rate and thereby increases runoff velocities and volumes. Use measures that break the slopes (Figure 1-4) to reduce the problems associated with concentrated flow volumes and runoff velocities. Practical ways to reduce velocities include conveying stormwater runoff away from steep slopes to stabilized outlets, preserving natural vegetation where possible, and mulching and vegetating exposed areas immediately after construction.

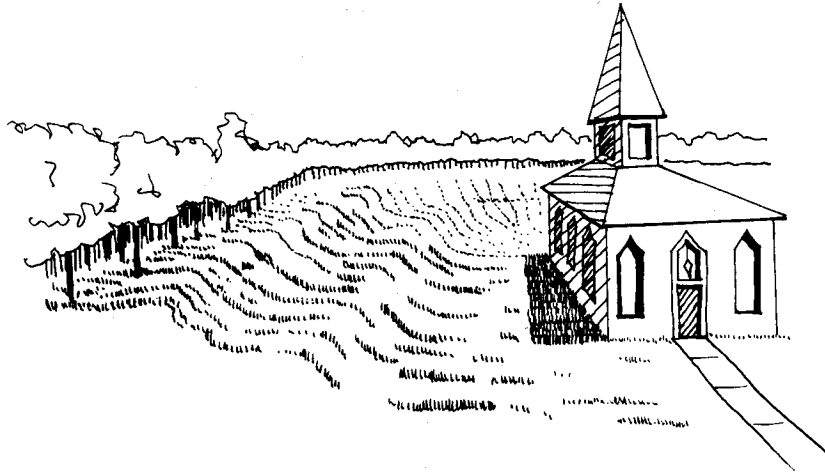

**Figure 1-4 Slow Runoff by Breaking Slopes (North Carolina, 1993)**

Benches, terraces, or ditches break up a slope by providing areas of low slope in the reverse direction. This keeps water from proceeding down the slope at increasing volume and velocity. Instead, the flow is directed to a suitable outlet, such as a sediment basin or trap. The frequency of benches, terraces, or ditches will depend on the erodibility of the soils, steepness and length of the slope, and rock outcrops. This practice should be used if there is a potential for erosion along the slope.

Use retaining walls. Often retaining walls can be used to decrease the steepness of a slope. If the steepness of a slope is reduced, the runoff velocity is decreased and therefore, the erosion potential is decreased. Retaining walls also may actually encourage water to infiltrate rather than runoff, thereby helping maintain the natural hydrologic characteristics of a site.

Provide linings for urban runoff conveyance channels. Construction often increases the velocity and volume of runoff, which causes erosion in newly constructed or existing urban runoff conveyance channels. If the runoff during or after construction will cause erosion in a channel, the channel should be lined or flow control BMPs installed. The first choice of lining should be grass or sod since this reduces runoff velocities and provides water quality benefits through filtration and infiltration. If the velocity in the channel would erode the grass or sod, then riprap, concrete, or gabions can be used.

Use check dams. Check dams are small, temporary dams constructed across a swale or channel. They can be constructed using gravel or straw bales. They are used to reduce the velocity of concentrated flow and, therefore, to reduce the erosion in a swale or channel. Check dams should be used when a swale or channel will be used for a short time and therefore it is not feasible or practical to line the channel or implement flow control BMPs.

### *Site Stabilization*

Removing the vegetative cover and altering the soil structure by clearing, grading, and compacting the surface increases an area's susceptibility to erosion. Apply stabilizing measures as soon as possible after the land is disturbed (Figure 1-5). Plan and implement temporary or permanent vegetation, mulches, or other protective practices to correspond with construction activities. Protect channels from erosive forces by using protective linings and the appropriate channel design. Consider possible future repairs and maintenance of these practices in the design.

Seeding establishes a vegetative cover on disturbed areas. Seeding is very effective in controlling soil erosion once a vegetative cover of about 80% has been established. However, often seeding and fertilizing do not produce as thick a vegetative cover as do seed and mulch or netting. Newly established vegetation does not have as extensive a root system as existing vegetation and therefore is more prone to erosion, especially on steep slopes. Care should be taken when fertilizing to avoid untimely or excessive application. Since the practice of seeding and fertilizing does not provide any protection during the time of vegetative establishment, it should be used only on favorable soils in very flat areas and not in sensitive areas.

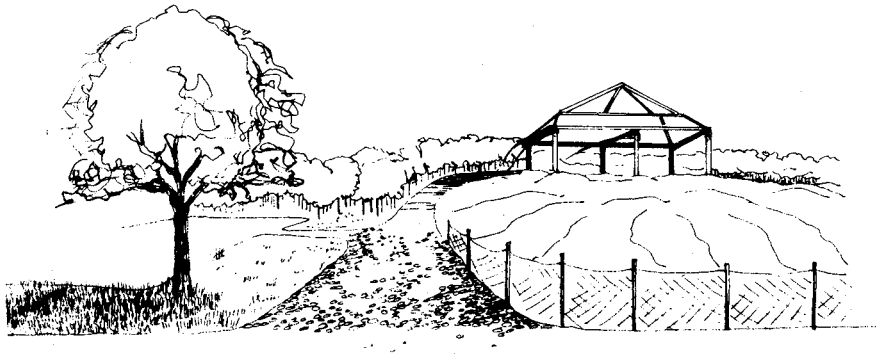

**Figure 1-5 Stabilization of Disturbed Areas (North Carolina, 1993)**

The management of land by using ground cover reduces erosion by reducing the flow rate of runoff and the raindrop impact. Bare soils should be seeded or otherwise stabilized within 14 calendar days after final grading or where construction activity has temporarily ceased for more than 21 days. In very flat, non-sensitive areas with favorable soils, stabilization may involve simply seeding and fertilizing. Mulch and/or sod may be necessary on steeper slopes, for erodible soils, and near sensitive areas. Sediment that has escaped the site due to the failure of sediment and erosion controls should be removed as soon as possible to minimize offsite impacts. Permission should be obtained from adjacent landowners prior to offsite sediment removal.

Mulching/mats can be used to protect the disturbed area while vegetation becomes established. Mulching involves applying plant residues or other suitable materials on disturbed soil surfaces. Mulches/mats used include tacked straw, wood chips, and jute netting and are often covered by blankets or netting. Mulching alone should be used only for temporary protection of the soil surface or when permanent seeding is not feasible. The useful life of mulch varies with the material used and the amount of precipitation, but is approximately 2 to 6 months.

During times of year when vegetation cannot be established, soil mulching should be applied to moderate slopes and soils that are not highly erodible. On steep slopes or highly erodible soils, multiple mulching treatments should be used. Interlocking ceramic materials, filter fabric, and netting are available for this purpose. Before stabilizing an area, it is important to have installed all sediment controls and diverted runoff away from the area to be planted. Runoff may be diverted away from denuded areas or newly planted areas using dikes, swales, or pipe slope drains to intercept runoff and convey it to a permanent channel or storm drain. Reserved topsoil may be used to revegetate a site if the stockpile has been covered and stabilized.

Consideration should be given to maintenance when designing mulching and matting schemes. Plastic nets are often used to cover the mulch or mats; however, they can foul lawn mower blades if the area requires mowing.

Sod can be used to permanently stabilize an area. Sodding provides immediate stabilization of an area and should be used in critical areas or where establishment of permanent vegetation by seeding and mulching would be difficult. Sodding is also a preferred option when there is high erosion potential during the period of vegetative establishment from seeding.

Because of the hardy drought-resistant nature of wildflowers, they may be more beneficial as an erosion control practice than turf grass. While not as dense as turfgrass, wildflower thatches and associated grasses are expected to be as effective in erosion control and contaminant absorption. Because thatches of wildflowers do not need fertilizers, pesticides, or herbicides, and the need for watering is minimal, implementation of this practice may result in cost savings. In 1987, Howard County, Maryland, spent \$690.00 per acre to maintain turfgrass areas, compared to only \$31.00 per acre for wildflower meadows. A wildflower stand requires several years to become established; however, maintenance requirements are minimal once the area is established.

#### *Plan for Temporary Structural Controls*

Retain Sediment on the Site. Even with careful planning, some erosion is unavoidable. The resulting sediment must be trapped on the site. Plan the location where sediment deposition will occur and maintain access for cleanout. Protect low points below disturbed areas by building barriers to reduce sediment loss. Whenever possible, plan and construct sediment traps and basins before other land-disturbing activities (Figure 1-6).



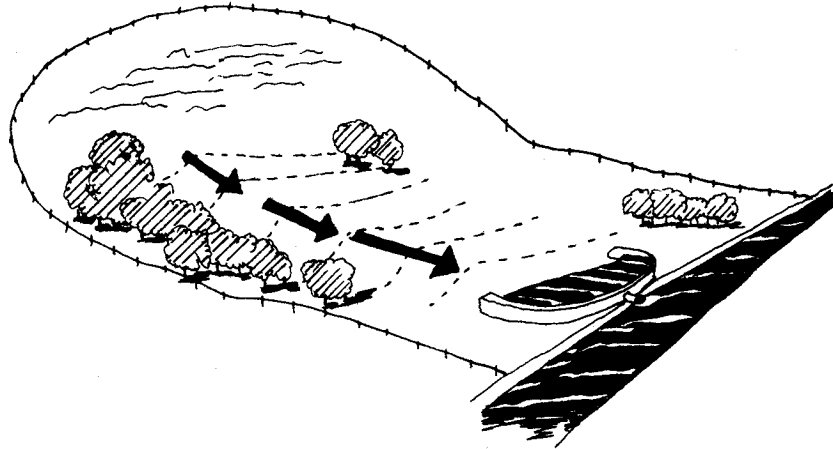

**Figure 1-6 Retention of Eroded Sediment on Site**

### ***1.3 Temporary Erosion Control BMPs***

Temporary erosion controls should be considered the first line of defense for prevention of water pollution during construction activities. It is much simpler to maintain the soil cover than to trap the sediment once it has been mobilized. In addition effective erosion prevention can result in cost savings, since repair of erosion damage can be minimized.

The primary goal of erosion control is to divert runoff away from unstable areas or to provide a stable surface that will resist the effects of rain and runoff. The principle measures for diverting runoff include perimeter swales and dikes, and slope drains. These measures can direct flow around the active construction area or transport stormwater runoff across unstable areas.

The flow in swales, dikes, and storm drain systems should be discharged in such a way that erosion is minimized. Therefore, outlet stabilization and level spreaders should be implemented to reduce the effects of concentrated flow.

Existing trees and vegetation should be protected to help maintain a stable ground surface and prevent loss of valuable topsoil. Where temporary vegetation is used to prevent erosion, blankets, matting and mulches can stabilize the area until the vegetation is established.

The following sections describe some of the common erosion controls. The types and application of the controls are summarized in Table 1-1.

**Table 1-1 Summary of Temporary Erosion Control Practices**

| Practice             | Area          | Application   | Notes  |
|----------------------|---------------|---|--|
| Interceptor Swale    | < 5 ac        | Used as a perimeter control or to shorten slope   | Maximum flow velocity 6 ft/s unless stabilized         |
| Diversion Dike       | <10 ac        | Used to route runoff away from disturbed areas  |  |
| Pipe Slope Drain     | <5 ac         | Transport runoff down steep, erodible slopes  |  |
| Polyacrylamide (PAM) | NA            | Erosion control   |  |
| Outlet Stabilization | NA            | Prevent erosion at outlet of channel or conduit   |  |
| Level Spreader       | Based on flow | Outlet device for dikes and diversions  | Slope <10% and stable, flowrate <20 cfs                |
| Subsurface Drain     | NA            | Prevent soils from becoming saturated and prevent seeps                                     |  |
| Temporary Vegetation | NA            | Temporary stabilization of disturbed areas  | One of the most effective measures, highly recommended |
| Blankets/Matting     | NA            | Used in channels and on steep slopes  | Slope <15%   |
| Hydraulic Mulch      | NA            | Stabilization of newly seeded areas   | Slope <15%   |
| Sod                  | NA            | Immediate stabilization in channels, around inlets, or for aesthetics                       |  |
| Dust Control         | NA            | In areas subject to surface and air movement of dust where on- or off-site damage may occur |  |

### 1.3.1 Interceptor Swale

Interceptor swales are used to shorten the length of exposed slope by intercepting runoff and can also serve as perimeter swales preventing off-site runoff from entering the disturbed area or prevent sediment-laden runoff from leaving the construction site or disturbed area. They may have a v-shape or be trapezoidal with a flat bottom and side slopes of 3:1 or flatter. The outflow from a swale should be directed to a stabilized outlet or sediment-trapping device. The swales should remain in place until the disturbed area is permanently stabilized. A schematic of an interceptor swale is shown in Figure 1-7.

#### **Materials:**

- (1) Stone stabilization should be used when grades exceed 2% or velocities exceed 6 feet per second and should consist of a layer of crushed stone three inches thick, riprap or high velocity erosion control mats.
- (2) Stabilization should extend across the bottom of the swale and up both sides of the channel to a minimum height of three inches above the design water surface elevation based on a 2-year, 24-hour storm.

#### **Installation:**

- (3) An interceptor swale should be installed across exposed slopes during construction and should intercept no more than 5 acres of runoff.
- (4) All earth removed and not needed in construction should be disposed of in an approved spoils site so that it will not interfere with the functioning of the swale or contribute to siltation in other areas of the site.
- (5) All trees, brush, stumps, obstructions and other material should be removed and disposed of so as not to interfere with the proper functioning of the swale.
- (6) Swales should have a maximum depth of 1.5 feet with side slopes of 2:1 or flatter. Swales should have positive drainage for its entire length to an outlet.
- (7) When the slope exceeds 2 percent, or velocities exceed 6 feet per second (regardless of slope), stabilization is required. Stabilization should be crushed stone placed in a layer of at least 3 inches thick or may be high velocity erosion control matting. Check dams are also recommended to reduce velocities in the swales possibly reducing the amount of stabilization necessary.
- (8) Minimum compaction for the swale should be 90% standard proctor density.

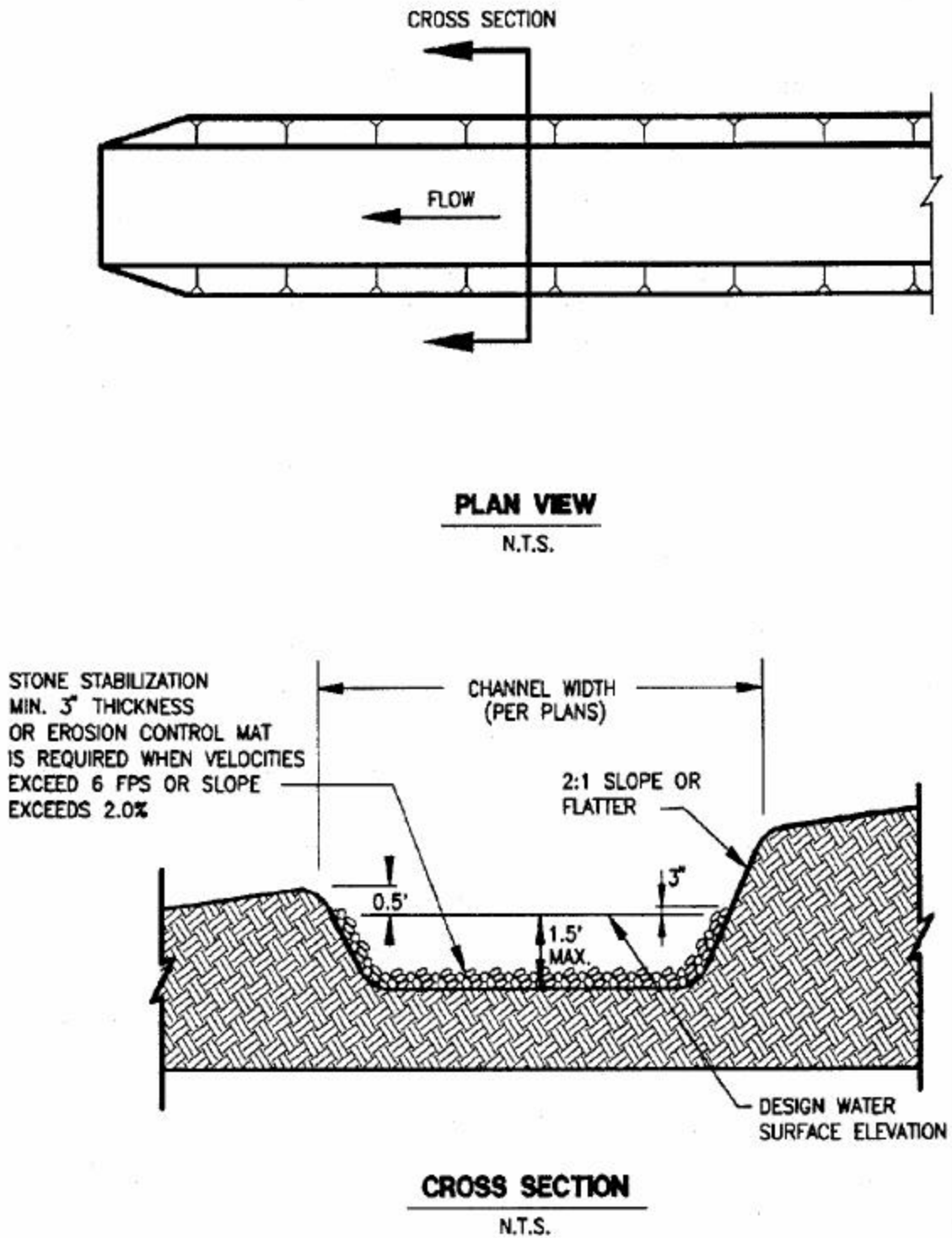

Figure 1-7 Schematic Diagram of an Interceptor Swale

**Inspection and Maintenance Guidelines:**

- (1) Interceptor swales should be inspected weekly and after each rain event to locate and repair any damage to the channel or clear debris or other obstructions so as not to diminish flow capacity.
- (2) Damage from storms or normal construction activities such as tire ruts or disturbance of swale stabilization should be repaired as soon as practical.

1.3.2 Diversion Dikes

A temporary diversion dike is a barrier created by the placement of an earthen embankment to reroute the flow of runoff to an erosion control device or away from an open, easily erodible area. A diversion dike intercepts runoff from small upland areas and diverts it away from exposed slopes to a stabilized outlet, such as a rock berm, sandbag berm, or stone outlet structure. These controls can be used on the perimeter of the site to prevent runoff from entering the construction area. Dikes are generally used for the duration of construction to intercept and reroute runoff from disturbed areas to prevent excessive erosion until permanent drainage features are installed and/or slopes are stabilized. A schematic of a diversion dike is shown in Figure 1-8.

**Materials:**

- (1) Stone stabilization (required for velocities in excess of 6 fps) should consist of riprap placed in a layer at least 3 inches thick and should extend a minimum height of 3 inches above the design water surface up the existing slope and the upstream face of the dike. Stabilization riprap should conform to the following specifications

| Channel Grade | Riprap Stabilization |
|---------------|----------------------|
| 0.5 – 1%      | 4 inch rock          |
| 1.1 – 2%      | 6 inch rock          |
| 2.1 – 4 %     | 8 inch rock          |
| 4.1 – 5%      | 8 – 12 inch riprap   |

- (2) Geotextile fabric should be a non-woven polypropylene fabric designed specifically for use as a soil filtration media with an approximate weight of 6 oz./yd<sup>2</sup>, a Mullen burst rating of 140 psi, and having an equivalent opening size (EOS) greater than a #50 sieve.

**Installation:**

- (1) Diversion dikes should be installed prior to and maintained for the duration of construction and should intercept no more than 10 acres of runoff.
- (2) Dikes should have a minimum top width of 2 feet and a minimum height of compacted fill of 18 inches measured from the top of the existing ground at the upslope toe to top of the dike and having side slopes of 2:1 or flatter.
- (3) The soil for the dike should be placed in lifts of 8 inches or less and be compacted to 95 % standard proctor density.
- (4) The channel, which is formed by the dike, must have positive drainage for its entire length to an outlet.
- (5) When the slope exceeds 2 percent, or velocities exceed 6 feet per second (regardless of slope), stabilization is required. Situations in which velocities do not exceed 6 feet per second, vegetation may be used to control erosion.

**Inspection and Maintenance Guidelines:**

- (1) Swales should be inspected weekly and after each rain event to determine if silt is building up behind the dike or if erosion is occurring on the face of the dike. Locate and repair any damage to the channel or clear debris or other obstructions so as not to diminish flow capacity.
- (2) Silt should be removed in a timely manner to prevent remobilization and to maintain the effectiveness of the control.
- (3) If erosion is occurring on the face of the dike, the slopes of the face should either be stabilized through mulch or seeding or the slopes of the face should be reduced.
- (4) Damage from storms or normal construction activities such as tire ruts or disturbance of swale stabilization should be repaired as soon as practical.

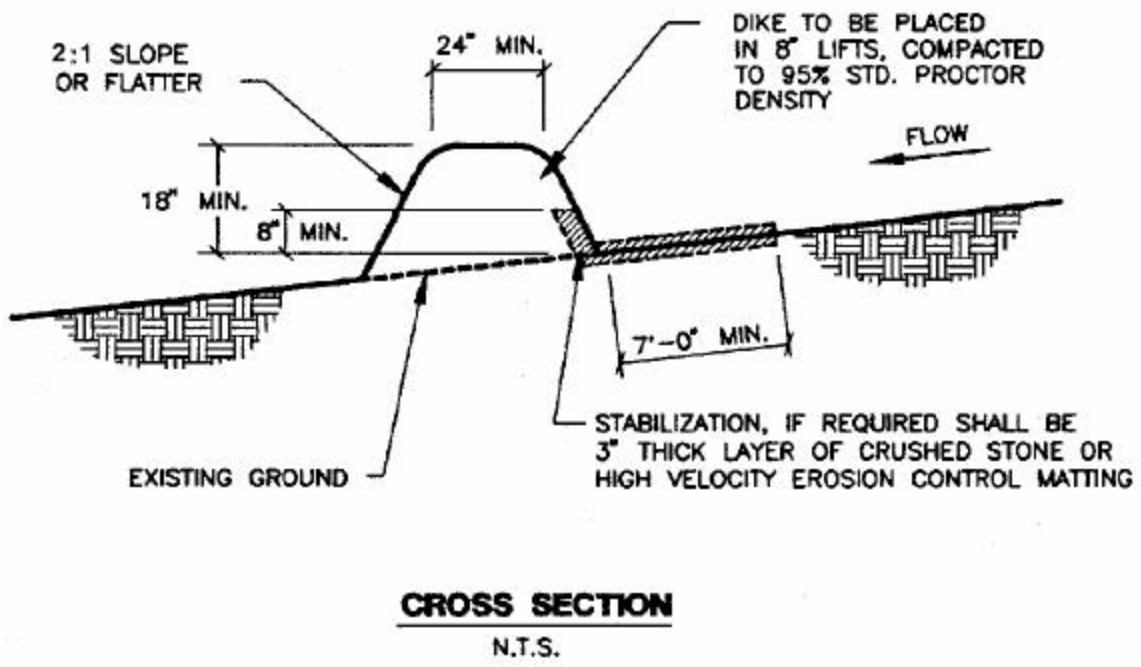
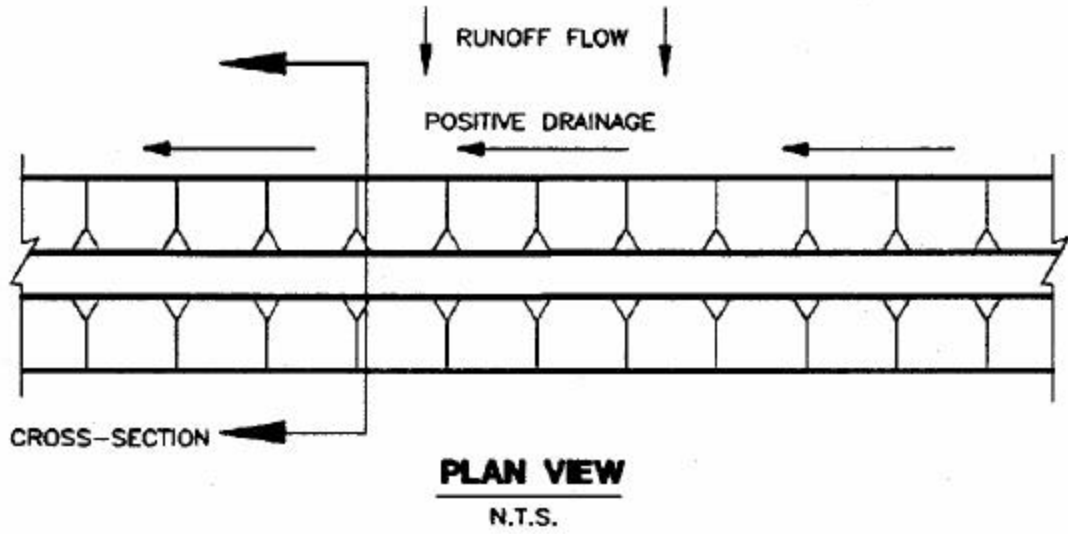

Figure 1-8 Schematic of a Diversion Dike (NCTCOG, 1993b)

### 1.3.3 Pipe Slope Drain

A temporary pipe slope drain is an erosion control device that combines an earthen embankment and a pipe to carry runoff over an exposed slope to a stabilized outlet apron. The maximum area contributing to any one drain should be 5 acres or less and the pipe should be sized to convey the 10-yr, 3-hr storm. A diagram of a slope drain is shown in Figure 1-9.

#### **Materials:**

- (1) The drain pipe may be made of any material, rigid or flexible, which is capable of conveying runoff. The drainpipe should be completely watertight so that no water leaks on to the slope to be protected.
- (2) Riprap to be used in the outlet apron should consist of either crushed stone or broken Portland cement concrete. All stones used should weigh between 50 and 150 pounds each and should be as nearly uniform as is practical.

#### **Installation:**

- (1) A diversion dike should be constructed at the top of the slope that is to be protected. This dike should be sized so that no runoff may overtop the dike. The soil around and under the entrance section of the drainpipe should be hand-tamped in 8-inch lifts to prevent piping failure around the inlet.
- (2) The height of the diversion dike at the centerline of the inlet should be equal to the diameter of the pipe plus 12 inches.
- (3) A rigid section of pipe should be installed through the dike. A standard flared-end section with an integral toe plate extending a minimum of 6-inches from the bottom of the end section should be attached to the inlet end of the pipe using watertight fittings.
- (4) A riprap-lined apron should be excavated to accept the runoff from the pipe and dissipate the energy of the flow. The width of the bottom of the apron should be 3 times the pipe diameter and the length should be a minimum of 6 times the pipe diameter. The apron should be a minimum of 12-inches deep and lined with riprap with a thickness of at least 12 inches. The apron should be designed so that the released flow has a velocity less than 3 feet per second.



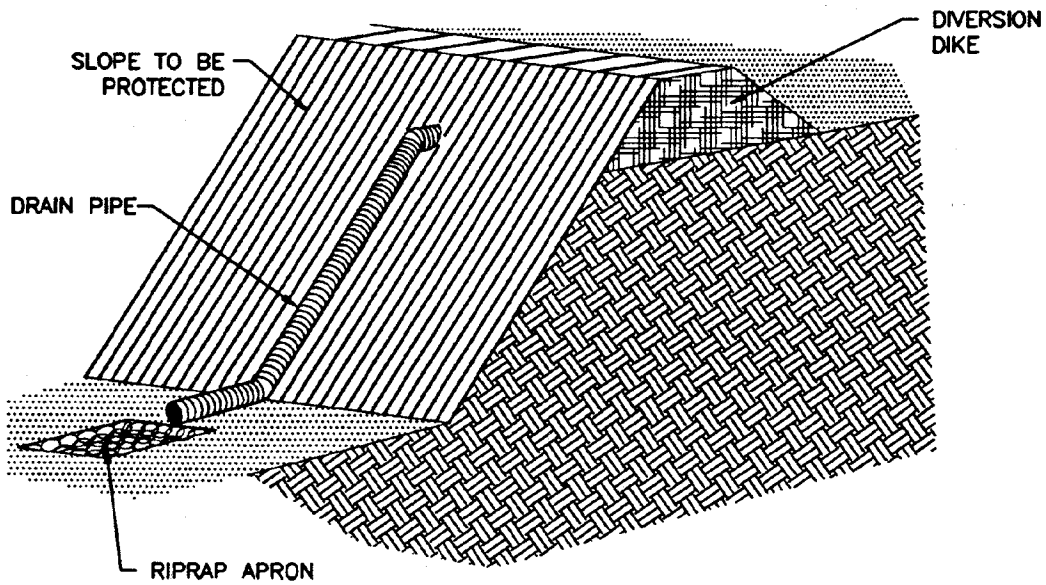

**ISOMETRIC PLAN VIEW**

N.T.S.

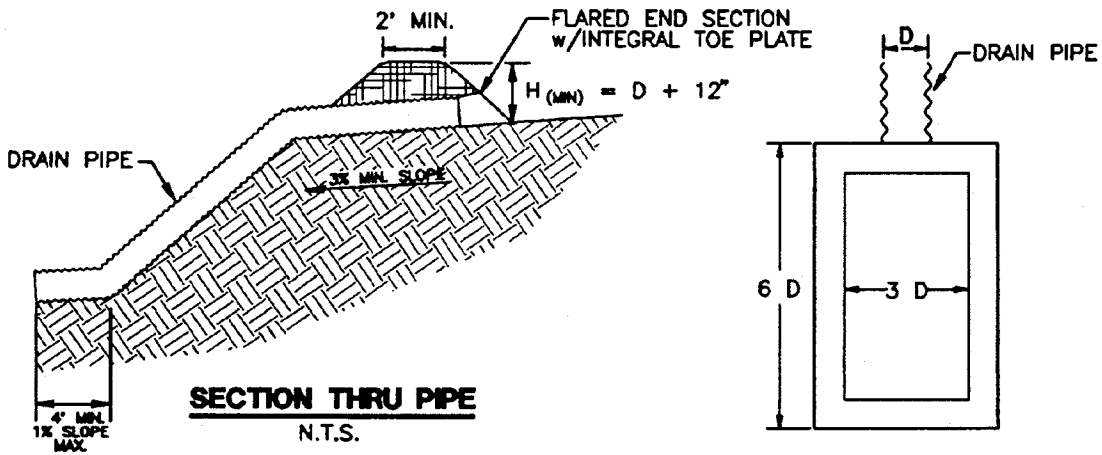

**SECTION THRU PIPE**

N.T.S.

**RIPRAP APRON PLAN VIEW**

N.T.S.

RIPRAP SHALL CONSIST OF 50 TO 150 POUND STONES PLACED IN A LAYER OF NOT LESS THAN 12 INCHES. THE DEPTH OF THE APRON SHALL EQUAL THE PIPE DIAMETER BUT IN NO CASE SHALL IT BE LESS THAN 12 INCHES.

Figure 1-9 Schematic Diagram of a Slope Drain (NCTCOG, 1993)

### **Inspection and Maintenance Guidelines:**

- (1) Pipe slope drains should be inspected weekly and after each rain event to locate and repair any damage to joints or clogging of the pipe.
- (2) In cases where the diversion dike has deteriorated around the entrance of the pipe, it may be necessary to reinforce the dike with sandbags or to install a concrete collar to prevent failure.
- (3) Signs of erosion around the pipe drain should be addressed in a timely manner by stabilizing the area with erosion control mats, crushed stone, concrete or other appropriate method.

#### 1.3.4 Polyacrylamide

Polyacrylamide (PAM) is a chemical that can be applied to disturbed soils at construction sites to reduce erosion and improve settling of suspended sediment. PAM increases the soil's available pore volume, thus increasing infiltration and reducing the quantity of stormwater runoff that can cause erosion. Suspended sediments from PAM treated soils exhibit increased flocculation over untreated soils. The increased flocculation aids in their deposition, thus reducing stormwater runoff turbidity and improving water quality.

Pam shall be used in conjunction with other BMPs and not in place of other erosion and sediment control BMPs. Stormwater runoff from PAM treated soils should pass through a sediment control BMP prior to discharging to surface waters. Do not add PAM to water discharging from site.

On PAM treated sites, the use of silt fence and fiber rolls shall be maximized to limit the discharges of sediment to sediment traps and sediment basins. All areas not being actively worked should be covered and protected from rainfall. PAM should not be the only cover BMP used.

### **Materials:**

- (1) Some PAMs are more toxic and carcinogenic than others. Only the most environmentally safe PAM products should be used.
- (2) The specific PAM copolymer formulation must be anionic. **Cationic PAM shall not be used in any application because of known aquatic toxicity problems.** Only the highest drinking water grade PAM, certified for compliance with ANSI/NSF Standard 60 for drinking water treatment, will be used for soil applications. Formulations that meet this standard are available at: <http://www.nsf.org/Certified/PwsChemicals/Listings.asp?CompanyName=&TradeName=&ChemicalName=Polyacrylamide&ProductFunction=&PlantState=&PlantCountry=>

- (3) PAM designated for erosion and sediment control should be “water soluble” or “linear” or “non-cross linked”
- (4) Recent high interest in PAM has resulted in some entrepreneurial exploitation of the term “polymer”. All PAMs are polymer, but not all polymers are PAM, and not all PAM products comply with ANSI/NSF Standard 60.
- (5) The PAM anionic charge density may vary from 2-30%; a value of 18% is typical. Studies conducted by the United States Department of Agriculture (USDA)/Agricultural Research Service (ARS) demonstrated that soil stabilization was optimized by using very high molecular weight (12-15 mg/mole), highly anionic (>20% charge density) PAM.

### **Installation:**

- (1) PAM can be applied to wet soil, but dry soil is preferred due to less sediment loss.
- (2) Keep the granular PAM supply out of the sun. Granular PAM loses its effectiveness in three months after exposure to sunlight and air.
- (3) Proper application and re-application plans are necessary to ensure total effectiveness of PAM usage.
- (4) PAM, combined with water, is very slippery and can be a safety hazard. Care must be taken to prevent spills of PAM powder onto paved surfaces. During an application of PAM, prevent over spray from reaching pavement, as pavement will become slippery. If PAM powder gets on skin or clothing, wipe it off with a rough towel rather than washing with water this only makes cleanup messier and longer.
- (5) PAM tackifiers are available and being used in place of guar and alpha plantago. Typically, PAM tackifiers should be used at a rate of no more than 0.5-1 lb per 1,000 gallons of water in a hydro mulch machine. Some tackifier product instructions say to use at a rate of 3-5 lbs per acre, which can be too much. In addition, pump problems can occur at higher rates due to increased viscosity.
- (6) The preferred application method for PAM is dissolved in water. Other options include application in dry, granular, or powered form.
- (7) PAM is to be applied at a maximum rate of ½ pound PAM per 1000 gallons water per 1 acre of bare soil. Table 1-2 can be used to determine the PAM and water application rate for a disturbed soil area. Higher concentrations of PAM **do not** provide any additional effectiveness. Pre-measure the area where PAM is to be applied and calculate the amount of product and water necessary to provide coverage at the specified application rate.

- (8) PAM has infinite solubility in water, but dissolves very slowly. Dissolve pre-measured dry granular PAM with a known quantity of clean water in a bucket several hours or overnight. Mechanical mixing will help dissolve the PAM. Always add PAM to water – not water to PAM.
- (9) Pre-fill the water truck about 1/8 full with water. The water does not have to be potable, but it must have relatively low turbidity – in the range of 20 NTU or less.
- (10) Add the dissolved PAM and water mixture to the truck.
- (11) Fill the water truck to specified volume for the amount of PAM to be applied.
- (12) Spray the PAM/water mixture onto dry soil until the soil surface is uniformly and completely wetted.

**Table 1-2 Application Rates for PAM**

| <b>Disturbed Area (ac)</b> | <b>PAM (lbs)</b> | <b>Water (gallons)</b> |
|----------------------------|------------------|------------------------|
| 0.50                       | 0.25             | 500                    |
| 1.00                       | 0.50             | 1000                   |
| 1.50                       | 0.75             | 1,500                  |
| 2.00                       | 1.00             | 2,000                  |
| 2.50                       | 1.25             | 2,500                  |
| 3.00                       | 1.50             | 3,000                  |
| 3.50                       | 1.75             | 3,500                  |
| 4.00                       | 2.00             | 4,000                  |
| 4.50                       | 2.25             | 4,500                  |
| 5.00                       | 2.50             | 5,000                  |

**Alternate Installation:**

PAM may also be applied as a powder at the rate of 5 lbs per acre. This must be applied on a day that is dry. For areas less than 5-10 acres, a hand held “organ grinder” fertilizer spreader set to the smallest setting will work. Tractor mounted spreaders will work for larger areas.

**Inspection and Maintenance Guidelines:**

- (1) PAM must be reapplied on actively worked areas after a 48-hour period if PAM is to remain effective.
- (2) Reapplication is not required unless PAM treated soil is disturbed or unless turbidity levels show the need for an additional application.
- (3) If PAM treated soil is left undisturbed a reapplication may be necessary after two months.

- (4) More PAM applications may be required for steep slopes, silty and clayey soils (USDA Classification Type “C” and “D” soils), and long grades.
- (5) When PAM is applied first to bare soil and then covered with straw, a reapplication may not be necessary for several months.

### 1.3.5 Outlet Stabilization

The goal of outlet stabilization is to prevent erosion at the outlet of a channel or conduit by reducing the velocity of flow and dissipating the energy. This practice applies where the discharge velocity of a pipe, box culvert, diversion, open channel, or other water conveyance structure exceeds the permissible velocity of the receiving channel or disposal area.

The outlets of channels, conduits, and other structures are points of high erosion potential, because they frequently carry flows at velocities that exceed the allowable limit for the area downstream. To prevent scour and undermining, an outlet stabilization structure is needed to absorb the impact of the flow and reduce the velocity to non-erosive levels. A riprap-lined apron is the most commonly used practice for this purpose because of its relatively low cost and ease of installation. The riprap apron should be extended downstream until stable conditions are reached even though this may exceed the length calculated for design velocity control.

Riprap-stilling basins or plunge pools reduce flow velocity rapidly. They should be considered in lieu of aprons where overfalls exit at the ends of pipes or where high flows would require excessive apron length. Consider other energy dissipaters such as concrete impact basins or paved outlet structures (see Figure 1-10) where site conditions warrant.

#### **Materials:**

- (1) **Materials**—Ensure that riprap consists of a well-graded mixture of stone. Larger stone should predominate, with sufficient smaller sizes to fill the voids between the stones. The maximum stone diameter should be no greater than 1.5 times the  $d_{50}$  size.
- (2) **Thickness**—Make the minimum thickness of riprap 1.5 times the maximum stone diameter.
- (3) **Stone quality**—Select stone for riprap from field stone or quarry stone. The stone should be hard, angular, and highly weather-resistant. The specific gravity of the individual stones should be at least 2.5.
- (4) **Geotextile Fabric**—Install appropriate barrier to prevent soil movement through the openings in the riprap. The barrier should consist of a graded gravel layer or a synthetic filter cloth.

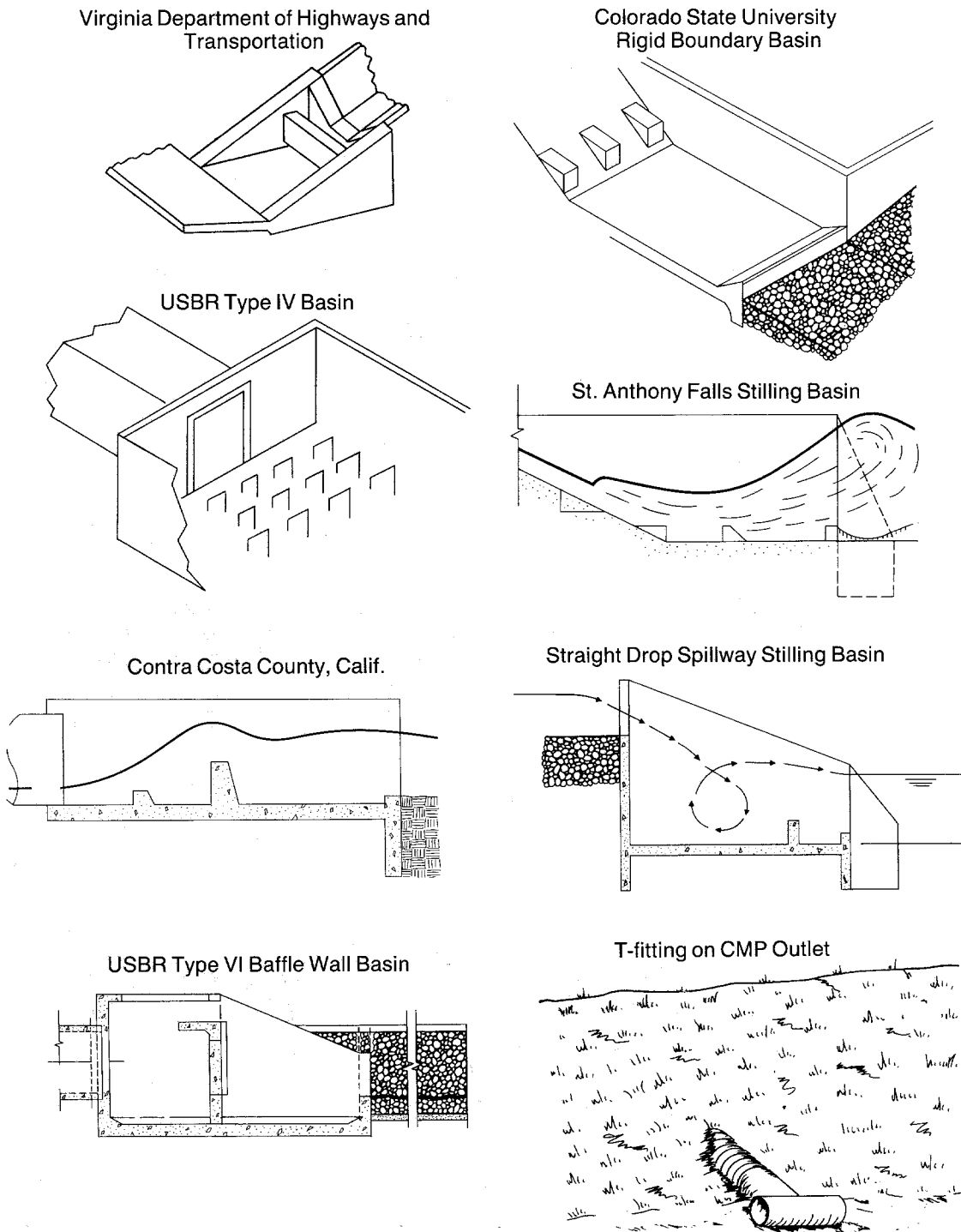

**Figure 1-10 Examples of Stilling Basin Designs (North Carolina, 1993)**

**Design Guidelines:**

- (1) Capacity—10-yr, 3-hour peak runoff or the design discharge of the water conveyance structure, whichever is greater.
- (2) Apron size—If the water conveyance structure discharges directly into a well-defined channel, extend the apron across the channel bottom and up the channel banks to an elevation of 0.5 ft above the maximum tailwater depth or to the top of the bank, whichever is less (see Figure 1-11). Determine the maximum allowable velocity for the receiving stream, and design the riprap apron to reduce flow to this velocity before flow leaves the apron. Calculate the apron length for velocity control or use the length required to meet stable conditions downstream, whichever is greater.
- (3) Grade—Ensure that the apron has zero grade. There should be no overfall at the end of the apron; that is, the elevation of the top of the riprap at the downstream end should be the same as the elevation of the bottom of the receiving channel or the adjacent ground if there is no channel.
- (4) Alignment—The apron should be straight throughout its entire length, but if a curve is necessary to align the apron with the receiving stream, locate the curve in the upstream section of riprap.

**Installation:**

- (1) Ensure that the subgrade for the fabric and riprap follows the required lines and grades shown in the plan. Compact any fill required in the subgrade to the density of the surrounding undisturbed material. Low areas in the subgrade on undisturbed soil may also be filled by increasing the riprap thickness.
- (2) The riprap and fabric must conform to the specified grading limits shown on the plans.
- (3) Filter cloth must be properly protected from punching or tearing during installation. Repair any damage by removing the riprap and placing another piece of filter cloth over the damaged area. All connecting joints should overlap a minimum of 1 ft. If the damage is extensive, replace the entire filter cloth.
- (4) Riprap may be placed by equipment, but take care to avoid damaging the fabric.

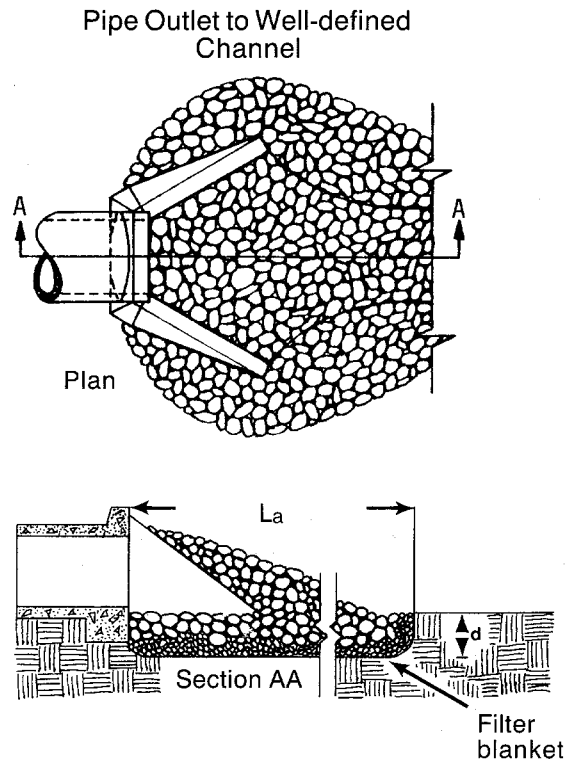
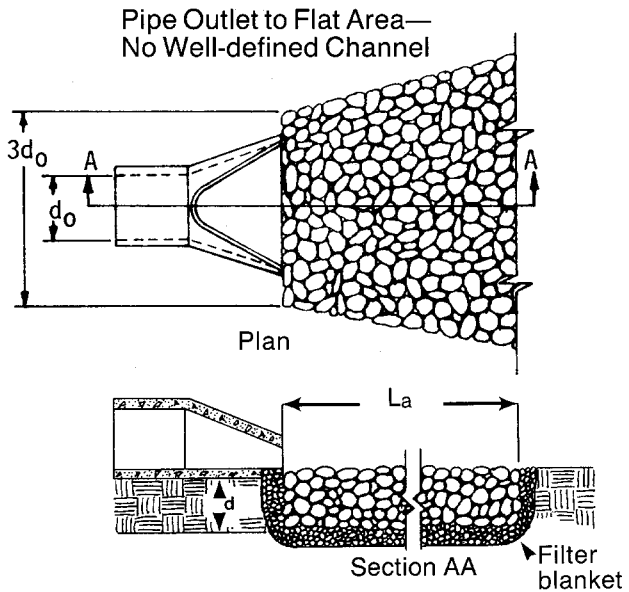

Notes

1.  $L_a$  is the length of the riprap apron.
2.  $d = 1.5$  times the maximum stone diameter but not less than 6".
3. In a well-defined channel extend the apron up the channel banks to an elevation of 6" above the maximum tailwater depth or to the top of the bank, whichever is less.
4. A filter blanket or filter fabric should be installed between the riprap and soil foundation.

Figure 1-11 Riprap Outlet Design (North Carolina, 1993)



- (5) The minimum thickness of the riprap should be 1.5 times the maximum stone diameter.
- (6) Riprap may be field stone or rough quarry stone. It should be hard, angular, highly weather-resistant and well graded.
- (7) Construct the apron on zero grade with no overfall at the end. Make the top of the riprap at the downstream end level with the receiving area or slightly below it.
- (8) Ensure that the apron is properly aligned with the receiving stream and preferably straight throughout its length. If a curve is needed to fit site conditions, place it in the upper section of the apron.
- (9) Immediately after construction, stabilize all disturbed areas with vegetation.

#### **Inspection and Maintenance Guidelines:**

- (1) Inspect riprap outlet structures after heavy rains to see if any erosion around or below the riprap has taken place or if stones have been dislodged. Immediately make all needed repairs to prevent further damage.

#### **1.3.6 Level Spreaders**

A level spreader is used as an outlet device for dikes and diversions and consists of an excavated depression constructed at zero grade across a slope. The purpose is to convert concentrated runoff to sheet flow and release it uniformly onto areas stabilized by existing vegetation.

Level spreaders should be used where there is a need to divert stormwater away from disturbed areas to avoid overstressing erosion control measures or where sediment free storm runoff can be released in sheet flow down a stabilized slope without causing erosion. A perspective view of a level spreader is shown in Figure 1-12.

This practice applies only in those situations where the spreader can be constructed on undisturbed soil and the area below the level lip is uniform with a slope of 10% or less and is stabilized by natural vegetation. The runoff water should not be allowed to re-concentrate after release unless it occurs during interception by another measure (such as a permanent pond or detention basin) located below the level spreader.

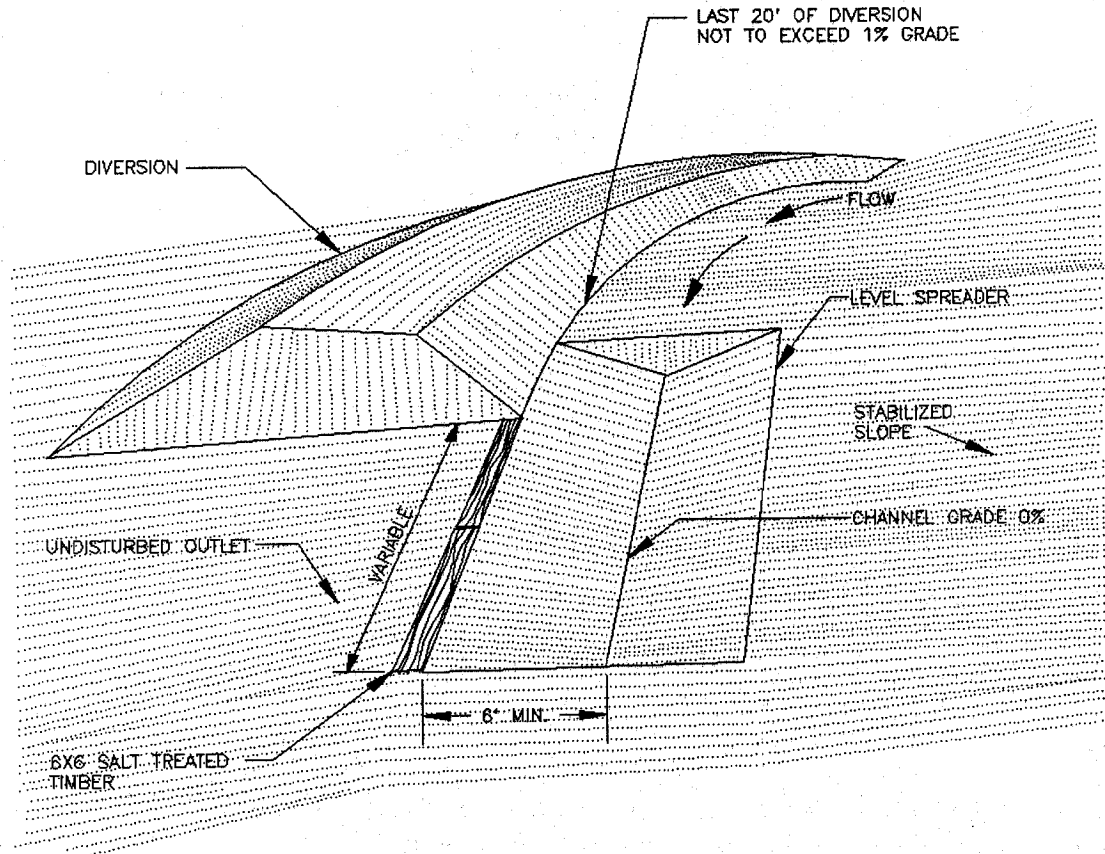

**Figure 1-12 Perspective View of a Level Spreader (VA Dept of Conservation, 1992)**

Particular care should be taken to construct the outlet lip completely level in a stable, undisturbed soil. Any depressions in the lip will concentrate the flow, resulting in erosion. Under higher design flow conditions, a rigid outlet lip design should be used to create the desired sheet flow conditions. Runoff water containing high sediment loads must be treated in a sediment-trapping device before being released to a level spreader.

**Installation:**

- (1) Level spreaders should be constructed on undisturbed soil (not fill material).
- (2) The entrance to the spreader should be shaped in such a manner as to insure that runoff enters directly onto the 0% grade channel.
- (3) Construct a 20-ft. transition section from the diversion channel to blend smoothly to the width and depth of the spreader.
- (4) The level lip should be constructed at 0% grade to insure uniform spreading of stormwater runoff.

- (5) The level lip may be stabilized by vegetation if the flow from the 2-year, 24-hour storm is expected to be less than 4 cfs, otherwise a rigid non-erodible material should be used.
- (6) Protective covering for vegetated lip should be a minimum of 4 feet wide extending 6 inches over the lip and buried 6 inches deep in a vertical trench on the lower edge. The upper edge should butt against smoothly cut sod and be securely held in place with closely spaced heavy-duty wire staples (see Figure 1-13).
- (7) Rigid level lip should be entrenched at least 2 inches below existing ground and securely anchored to prevent displacement. An apron of coarse aggregate should be placed to top of level lip and extended down slope at least 3 feet. Place filter fabric under stone and use galvanized wire mesh to hold stone securely in place (see Figure 1-13).
- (8) The released runoff must outlet onto undisturbed stabilized areas with slope not exceeding 10%. Slope must be sufficiently smooth to preserve sheet flow and prevent flow from concentrating.
- (9) Immediately after its construction, appropriately seed and mulch the entire disturbed area of the spreader.

### CROSS SECTION

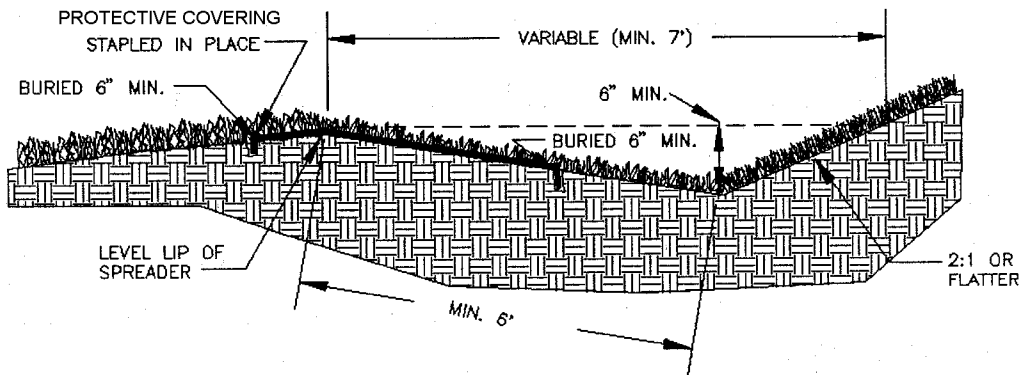

LEVEL SPREADER WITH VEGETATED LIP

### CROSS SECTION

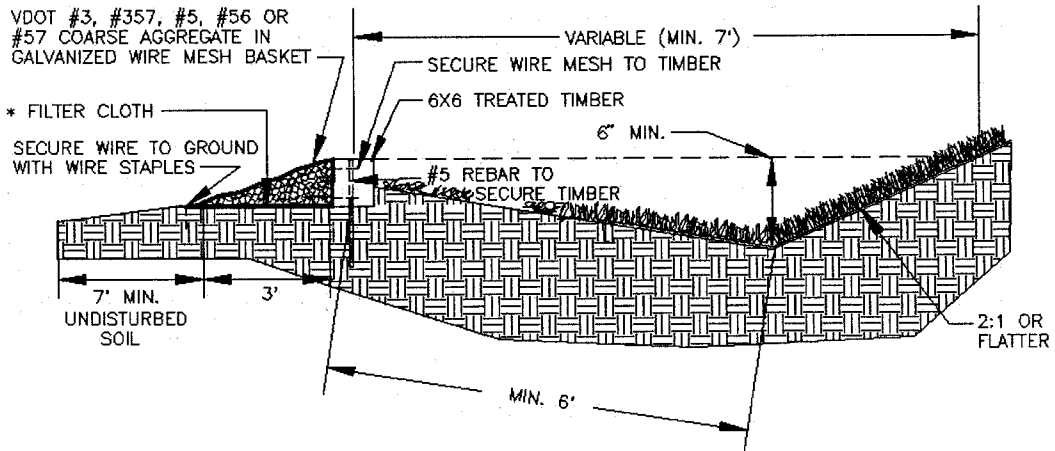

LEVEL SPREADER WITH RIGID LIP

Figure 1-13 Cross-Section of a Level Spreader (VA Dept of Conservation, 1992)

### Inspection and Maintenance Guidelines:

- (1) The measure should be inspected after every rainfall and repairs made, if required.
- (2) Level spreader lip should remain at 0% slope to allow proper function of measure.
- (3) The contractor should avoid the placement of any material on and prevent construction traffic across the structure. If the measure is damaged by construction traffic, it should be repaired immediately.

#### 1.3.7 Subsurface Drains

A subsurface drain is a perforated conduit such as pipe, tubing or tile installed beneath the ground to intercept and convey ground water. The main purposes are to: prevent sloping soils from becoming excessively wet and subject to sloughing, improve the quality of the growth medium in excessively wet areas by lowering the water table (see Figure 1-14), or drain stormwater detention areas or structures.

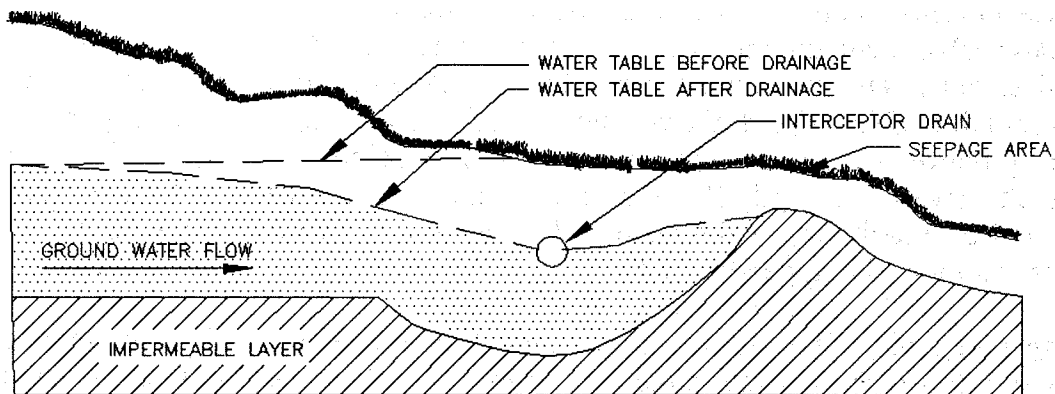

**Figure 1-14 Effect of Subsurface Drain (VA Dept. of Conservation, 1992)**

This measure is appropriate wherever excess water must be removed from the soil. This is generally not a problem on the recharge zone of the Edwards, but may be encountered in the contributing zone. The soil must be deep and permeable enough to allow an effective system to be installed. Either a gravity outlet must be available or pumping must be provided. These standards do not apply to foundation drains.

Subsurface drainage systems are of two types, relief drains and interceptor drains. Relief drains are used either to lower the water table in order to improve the growth of vegetation, or to remove surface water. They are installed along a slope and drain in the direction of the slope. They can be installed in a gridiron pattern, a herringbone pattern, or a random pattern (see Figure 1-15).

Interceptor drains are used to remove water as it seeps down a slope to prevent the soil from becoming saturated and subject to slippage. They are installed across a slope and drain to the side of the slope. They usually consist of a single pipe or series of single pipes instead of a patterned layout.

**Materials:**

Acceptable materials for subsurface drains include perforated, continuous closed-joint conduits of corrugated plastic, concrete, corrugated metal, asbestos cement, and bituminous fiber. The strength and durability of the pipe should meet the requirements of the site in accordance with the manufacturer's specifications.

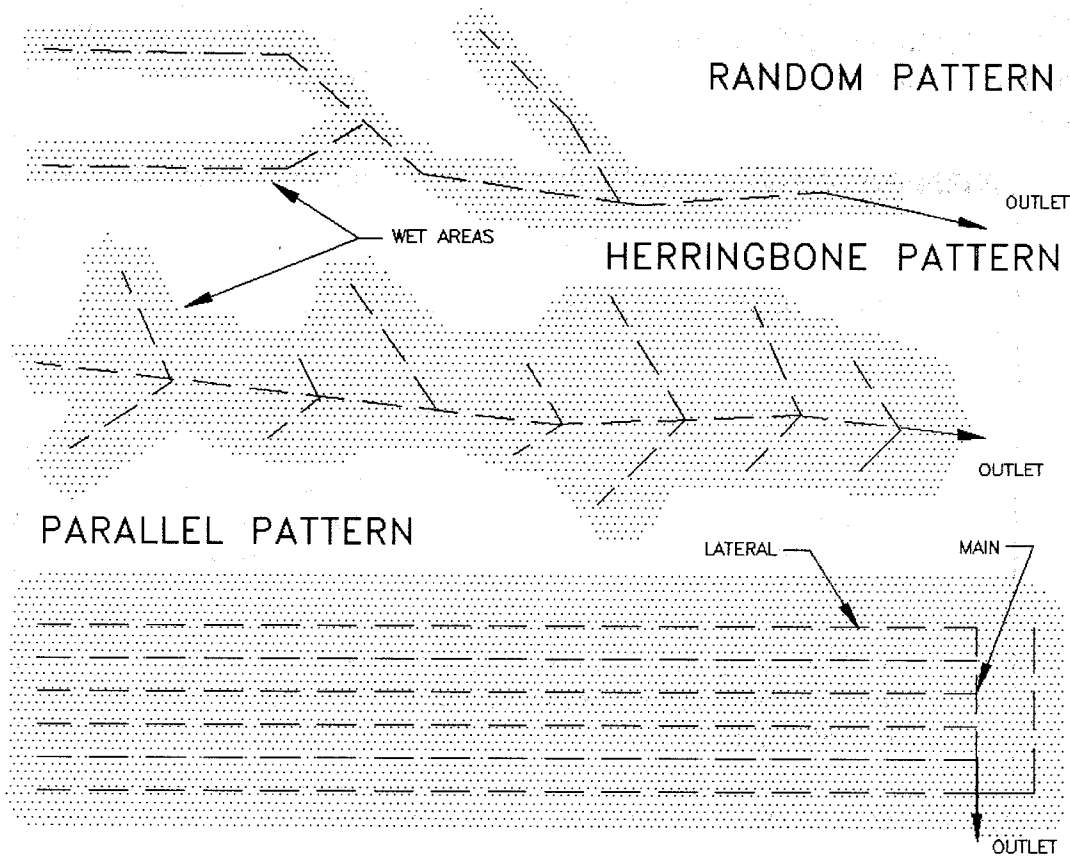

**Figure 1-15 Subsurface Drainage Patterns (VA Dept. of Conservation, 1992)**

### **General Installation Requirements:**

- (1) The trench should be constructed on a continuous grade with no reverse grades or low spots.
- (2) Soft or yielding soils under the drain should be stabilized with gravel or other suitable material.
- (3) Deformed, warped, or otherwise unsuitable pipe should not be used. The minimum diameter for a subsurface drain should be 4 inches.
- (4) Envelopes or filter material should be placed as specified with at least 3 inches of material on all sides of the pipe.
- (5) The trench should be backfilled immediately after placement of the pipe. No sections of pipe should remain uncovered overnight or during a rainstorm. Backfill material should be placed in the trench in such a manner that the drain pipe is not displaced or damaged.

### **Relief Drain Installation:**

- (1) Relief drains should be located through the center of wet areas. They should drain in the same direction as the slope.
- (2) Relief drains installed in a uniform pattern should remove a minimum of 1 inch of groundwater in 24 hours (0.042 cfs/acre). Relief drains installed in a random pattern should remove a minimum of 1.5 cfs/1000 feet of length. The design capacity should be increased accordingly to accommodate any surface water which enters directly into the system (see Figure 1-16).
- (3) Relief drains installed in a uniform pattern should have equal spacing between drains and the drains should be at the same depth. Maximum depth is limited by the allowable load on the pipe, depth to impermeable layers in the soil, and outlet requirements. The minimum depth is 24 inches under normal conditions. Twelve inches is acceptable where the drain will not be subject to equipment loading. Spacing between drains is dependent on soil permeability and the depth of the drain. In general, however, a depth of 3 feet and a spacing of 50 feet will be adequate.
- (4) The minimum velocity required to prevent silting is 1.4 ft/sec. The line should be graded to achieve at least this velocity. Steep grades should be avoided, however.
- (5) Envelopes should be used around all drains for proper bedding and improved flow of groundwater into the drain. The envelope should consist of 3 inches of aggregate placed completely around the drain. The stone should be encompassed by a filter cloth separator to prevent the migration of surrounding soil particles

into the drain (see Figure 1-17). Filter cloth must be designed specifically for soil filtration

- (6) The outlet of the subsurface drain should empty into a channel or some other watercourse that will remove the water from the outlet. It should be above the mean water level in the receiving channel. It should be protected from erosion, undermining, damage from periods of submergence, and the entry of small animals into the drain.

### **Interceptor Drain Installation:**

- (1) Interceptor drains should remove a minimum of 1.5 cfs/1000 feet of length. This value should be increased for sloping land. In addition, if a flowing spring or surface water enters directly into the system, this flow must be accommodated and the design capacity should be increased accordingly to take care of this flow.
- (2) The depth of installation of an interceptor drain is influenced mainly by the depth to which the water table is to be lowered. The maximum depth is limited by the allowable load on the pipe and the depth to an impermeable layer. Minimum depth should be the same as for relief drains.
- (3) One interceptor drain is usually sufficient; however, if multiple drains are to be used, determining the required spacing can be difficult. The best approach is to install the first drain - then if seepage or high water table problems occur down slope, install an additional drain a suitable distance down slope.

### **Inspection and Maintenance Guidelines:**

- (1) Subsurface drains should be checked weekly and after rainfall events to ensure that they are free flowing and not clogged with sediment.
- (2) The outlet should be kept clean and free of debris.
- (3) Surface inlets should be kept open and free of sediment and other debris.
- (4) Trees located too close to a subsurface drain often clog the system with their roots. If a drain becomes clogged, relocate the drain.
- (5) Where heavy vehicles cross drains, the line should be checked to ensure that it is not crushed.



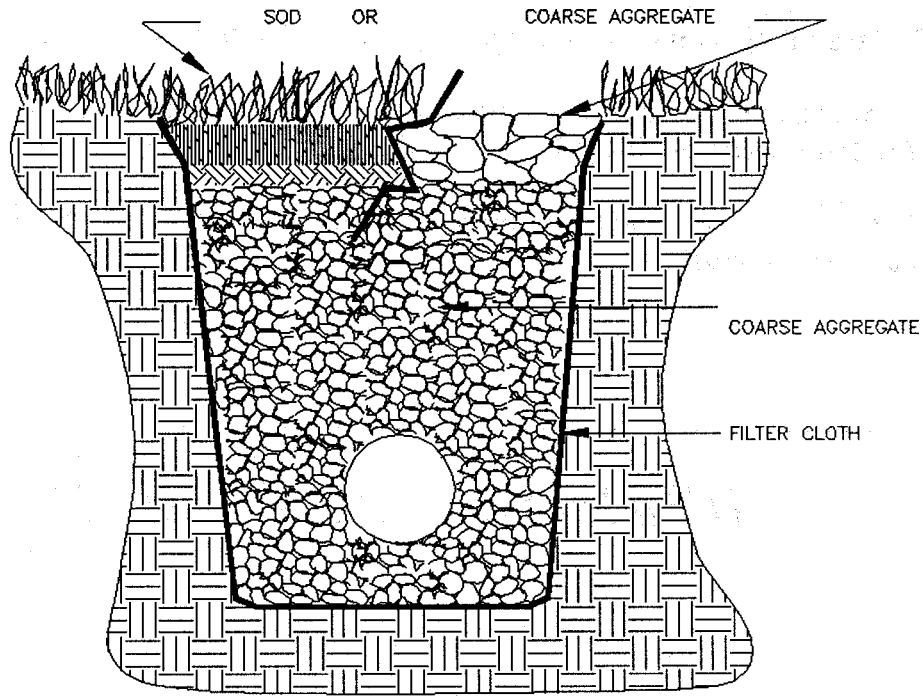

NATURAL INLET

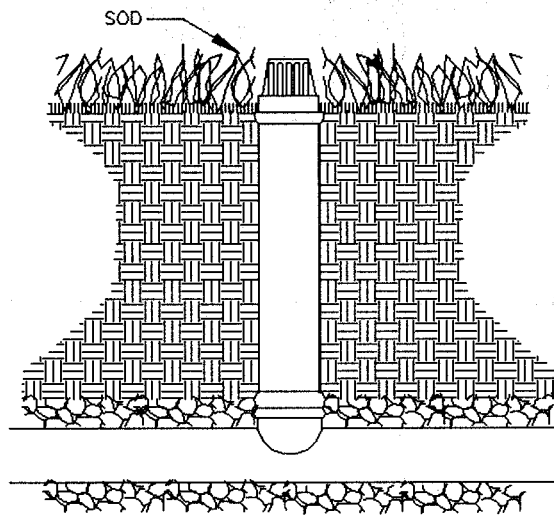

GRATED INLET

Figure 1-16 Surface Inlets for Subsurface Drains (VA Dept. of Conservation, 1992)

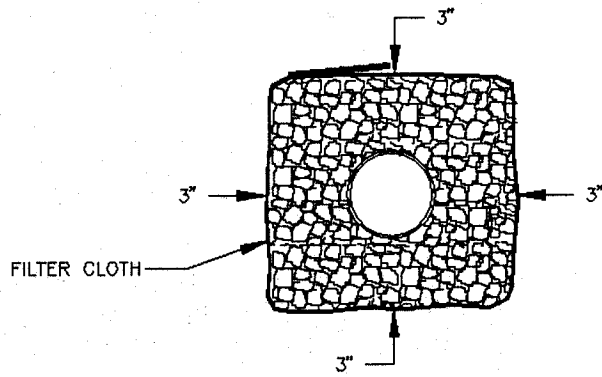

**Figure 1-17 Subsurface Drain Envelope (VA Dept. of Conservation, 1992)**

### 1.3.8 Temporary Vegetation

Vegetation is used as a temporary or permanent stabilization technique for areas disturbed by construction, but not covered by pavement, buildings, or other structures. As a temporary control, vegetation can be used to stabilize stockpiles and barren areas that are inactive for long periods of time.

Vegetative techniques can and should apply to every construction project with few exceptions. Vegetation effectively reduces erosion in swales, stockpiles, berms, mild to medium slopes, and along roadways.

Other techniques may be required to assist in the establishment of vegetation. These other techniques include erosion control matting, mulches, surface roughening, swales and dikes to direct runoff around newly seeded areas, and proper grading to limit runoff velocities during construction. (NCTCOG, 1993b)

#### **Materials:**

The type of temporary vegetation used on a site is a function of the season and the availability of water for irrigation. For areas that are not irrigated, the year can be divided into two temporary planting seasons and one season for planting of permanent warm weather groundcovers. These periods are shown in Figure 1-18 for Hays, Travis, and Williamson Counties. Planting times for Bexar, Comal, Kinney, Medina, and Uvalde Counties are shown in Figure 1-19. Appropriate temporary vegetation for these two areas are shown in Table 1-3 and Table 1-4.

Other vegetation may perform as well as the recommended varieties, especially where irrigation is available. County agricultural extension agents are a good source for suggestions for other types of temporary vegetation. All seed should be high quality, U.S. Dept. of Agriculture certified seed.

#### **Installation:**

- (1) Interim or final grading must be completed prior to seeding, minimizing all steep slopes. In addition, all necessary erosion structures such as dikes, swales, diversions, should also be installed.
- (2) Seedbed should be well pulverized, loose, and uniform.
- (3) Fertilizer should be applied at the rate of 40 pounds of nitrogen and 40 pounds of phosphorus per acre, which is equivalent to about 1.0 pounds of nitrogen and phosphorus per 1000 square feet. Compost can be used instead of fertilizer and applied at the same time as the seed.

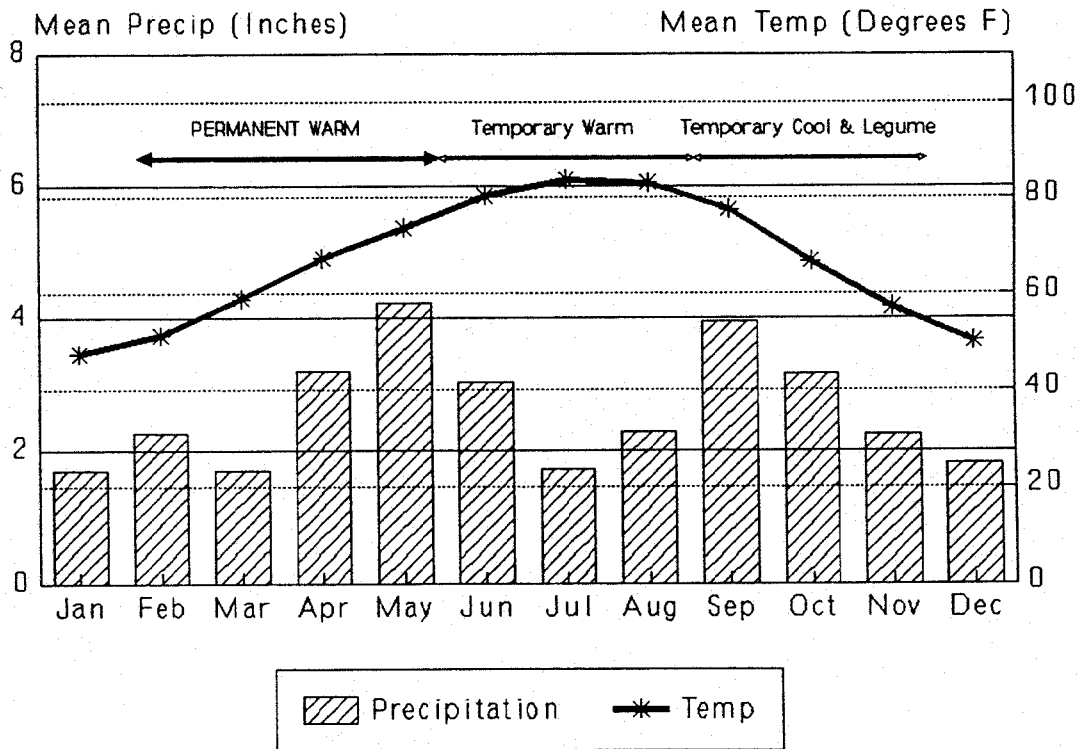

**Figure 1-18 Planting Dates for Hays, Travis, and Williamson Counties (Northcutt, 1993)**

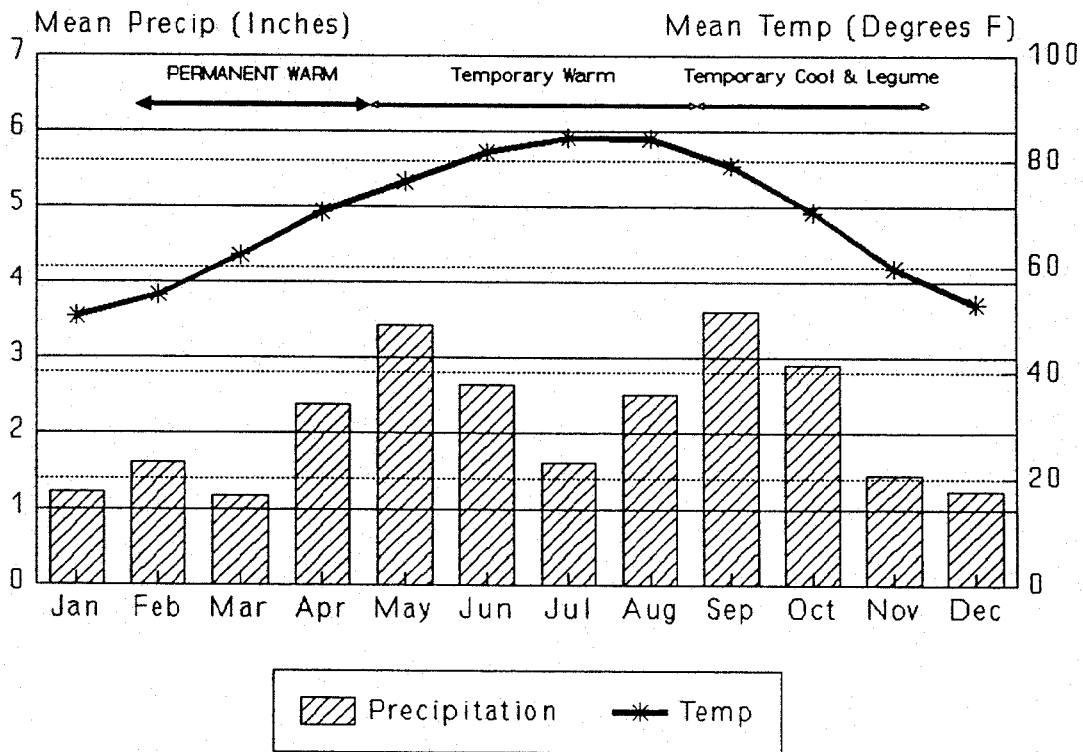

**Figure 1-19 Planting Dates for Bexar, Comal, Kinney, Medina, and Uvalde Counties (Northcutt, 1993)**

**Table 1-3 Temporary Seeding for Hays, Travis, and Williamson Counties (Northcutt, 1993)**

| <b>Dates</b>     | <b>Climate</b>        | <b>Species (lb/ac)</b>   |
|------------------|-----------------------|--------------------------|
| Sept 1 to Nov 30 | Temporary Cool Season | Tall Fescue 4.0          |
|                  |                       | Oats 21.0                |
|                  |                       | Wheat (Red, Winter) 30.0 |
|                  |                       | <b>Total 55.0</b>        |
| Sept 1 to Nov 30 | Cool Season Legume    | Hairy Vetch 8.0          |
| May 15 to Aug 31 | Temporary Warm Season | Foxtail Millet 30.0      |

**Table 1-4 Temporary Seeding for Bexar, Comal, Kinney, Medina, and Uvalde Counties (Northcutt, 1993)**

| <b>Dates</b>     | <b>Climate</b>        | <b>Species (lb/ac)</b>   |
|------------------|-----------------------|--------------------------|
| Sept 1 to Nov 30 | Temporary Cool Season | Tall Fescue 4.0          |
|                  |                       | Oats 21.0                |
|                  |                       | Wheat (Red, Winter) 30.0 |
|                  |                       | <b>Total 55.0</b>        |
| Sept 1 to Nov 30 | Cool Season Legume    | Hairy Vetch 8.0          |
| May 1 to Aug 31  | Temporary Warm Season | Foxtail Millet 30.0      |

- (4) Seeding rates should be as shown in Table 1-3 and Table 1-4 or as recommended by the county agricultural extension agent.
- (5) The seed should be applied uniformly with a cyclone seeder, drill, cultipacker seeder or hydroseeder (slurry includes seed, fertilizer and binder).
- (6) Slopes that are steeper than 3:1 should be covered with appropriate soil stabilization matting as described in the following section to prevent loss of soil and seed.

Irrigation

Temporary irrigation should be provided according to the schedule described below, or to replace moisture loss to evapotranspiration (ET), whichever is greater. Significant rainfall (on-site rainfall of ½” or greater) may allow watering to be postponed until the next scheduled irrigation.

| <b>Time Period</b>  | <b>Irrigation Amount and Frequency</b>   |
|---|--|
| Within 2 hours of installation                                    | Irrigate entire root depth, or to germinate seed   |
| During the next 10 business days                                  | Irrigate entire root depth every Monday, Wednesday, and Friday                                   |
| During the next 30 business days or until Substantial Completion  | Irrigate entire root depth a minimum of once per week, or as necessary to ensure vigorous growth |
| During the next 4 months or until Final Acceptance of the Project | Irrigate entire root depth once every two weeks, or as necessary to ensure vigorous growth       |

Refer to Figure 1, below, for average rainfall/ET data for the Edwards aquifer area. This data shall serve as a guide to the overall watering regime; however, actual frequency and amount of irrigation water used shall be weather-dependent.

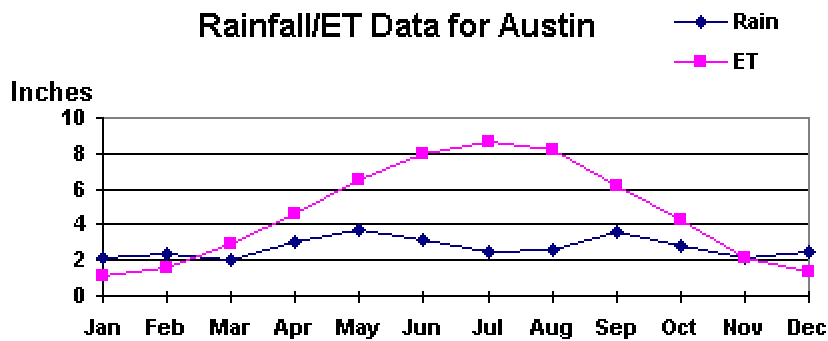

If cool weather induces plant dormancy, water only as necessary to maintain plant health. Irrigate in a manner that will not erode the topsoil but will sufficiently soak the entire depth of roots.

**Inspection and Maintenance Guidelines:**

- (1) Temporary vegetation should be inspected weekly and after each rain event to locate and repair any erosion.
- (2) Erosion from storms or other damage should be repaired as soon as practical by regrading the area and applying new seed.
- (3) If the vegetated cover is less than 80%, the area should be reseeded.

### 1.3.9 Blankets and Matting

Blankets and matting material can be used as an aid to control erosion on critical sites during establishment period of protective vegetation. The most common uses are: in channels where designed flow exceeds 3.5 feet per second; on interceptor swales and diversion dikes when design flow exceeds 6 feet per second; on short, steep slopes where erosion hazard is high and planting is likely to be slow to establish adequate protective cover; and on stream banks where moving water is likely to wash out new vegetative plantings.

Blankets and matting can also be used to create erosion stops on steep, highly erodible watercourses. Erosion stops should be placed approximately 3 feet down channel from point of entry of a concentrated flow such as from culverts, tributary channels or diversions or at points where a change in gradient or course of channel occurs. Spacing of erosion stops on long slopes will vary, depending on the erodibility of the soil and velocity and volume of flow. Erosion stops are placed beneath blankets and matting.

Biodegradable rolled erosion control products (RECPs) are typically composed of jute fibers, curled wood fibers, straw, coconut fiber, or a combination of these materials. In order for an RECP to be considered 100% biodegradable, the netting, sewing or adhesive system that holds the biodegradable mulch fibers together must also be biodegradable.

**Jute** is a natural fiber that is made into a yarn that is loosely woven into a biodegradable mesh. It is designed to be used in conjunction with vegetation and has longevity of approximately one year. The material is supplied in rolled strips, which should be secured to the soil with U-shaped staples or stakes in accordance with manufacturers' recommendations.

**Excelsior** (curled wood fiber) blanket material should consist of machine produced mats of curled wood excelsior with 80 percent of the fiber 6 in. or longer. The excelsior blanket should be of consistent thickness. The wood fiber must be evenly distributed over the entire area of the blanket. The top surface of the blanket should be covered with a photodegradable extruded plastic mesh. The blanket should be smolder resistant without the use of chemical additives and should be non-toxic and non-injurious to plant and animal life.

**Straw blanket** should be machine produced mats of straw with a lightweight biodegradable netting top layer. The straw should be attached to the netting with biodegradable thread or glue strips. The straw blanket should be of consistent thickness. The straw should be evenly distributed over the entire area of the blanket.

**Wood fiber blanket** is composed of biodegradable fiber mulch with extruded plastic netting held together with adhesives. The material is designed to enhance re-vegetation.

The material is furnished in rolled strips, which must be secured to the ground with U-shaped staples or stakes in accordance with manufacturers' recommendations.

**Coconut fiber blanket** should be a machine produced mat of 100 percent coconut fiber with biodegradable netting on the top and bottom. The coconut fiber should be attached to the netting with biodegradable thread or glue strips. The coconut fiber blanket should be of consistent thickness. The coconut fiber should be evenly distributed over the entire area of the blanket.

**Coconut fiber mesh** is a thin permeable membrane made from coconut or corn fiber that is spun into a yarn and woven into a biodegradable mat. It is designed to be used in conjunction with vegetation and typically has longevity of several years. The material is supplied in rolled strips, which must be secured to the soil with U-shaped staples or stakes in accordance with manufacturers' recommendations.

**Straw coconut fiber blanket** should be machine produced mats of 70 percent straw and 30 percent coconut fiber with a biodegradable netting top layer and a biodegradable bottom net. The straw and coconut fiber should be attached to the netting with biodegradable thread or glue strips. The straw coconut fiber blanket should be of consistent thickness. The straw and coconut fiber should be evenly distributed over the entire area of the blanket. Straw coconut fiber blanket should be furnished in rolled strips a minimum of 6.5 ft wide, a minimum of 80 ft long and a minimum of 0.5 lb/yd<sup>2</sup>. Straw coconut fiber blankets must be secured in place with wire staples. Staples should be made of minimum 11 gauge steel wire and should be U-shaped with 8 in. legs and 2 in. crown.

Non-biodegradable RECPs are typically composed of polypropylene, polyethylene, nylon or other synthetic fibers. In some cases, a combination of biodegradable and synthetic fibers is used to construct the RECP. Netting used to hold these fibers together is typically non-biodegradable as well.

**Plastic netting** is a lightweight biaxially oriented netting designed for securing loose mulches like straw or paper to soil surfaces to establish vegetation. The netting is photodegradable. The netting is supplied in rolled strips, which must be secured with U-shaped staples or stakes in accordance with manufacturers' recommendations.

**Plastic mesh** is an open weave geotextile that is composed of an extruded synthetic fiber woven into a mesh with an opening size of less than ¼ in. It is used with re-vegetation or may be used to secure loose fiber such as straw to the ground. The material is supplied in rolled strips, which must be secured to the soil with U-shaped staples or stakes in accordance with manufacturers' recommendations.

**Synthetic fiber with netting** is a mat that is composed of durable synthetic fibers treated to resist chemicals and ultraviolet light. The mat is a dense, three dimensional mesh of synthetic (typically polyolefin) fibers stitched between two polypropylene nets. The mats are designed to be re-vegetated and provide a permanent composite system of soil, roots,



and geomatrix. The material is furnished in rolled strips, which must be secured with U-shaped staples or stakes in accordance with manufacturers' recommendations.

**Bonded synthetic fibers** consist of a three dimensional geomatrix nylon (or other synthetic) matting. Typically it has more than 90 percent open area, which facilitates root growth. It's tough root reinforcing system anchors vegetation and protects against hydraulic lift and shear forces created by high volume discharges. It can be installed over prepared soil, followed by seeding into the mat. Once vegetated, it becomes an invisible composite system of soil, roots, and geomatrix. The material is furnished in rolled strips that must be secured with U-shaped staples or stakes in accordance with manufacturers' recommendations.

**Combination synthetic and biodegradable RECPs** consist of biodegradable fibers, such as wood fiber or coconut fiber, with a heavy polypropylene net stitched to the top and a high strength continuous filament geomatrix or net stitched to the bottom. The material is designed to enhance re-vegetation. The material is furnished in rolled strips, which must be secured with U-shaped staples or stakes in accordance with manufacturers' recommendations.

#### **Materials:**

New types of blankets and matting materials are continuously being developed. The Texas Department of Transportation (TxDOT) has defined the critical performance factors for these types of products, and has established minimum performance standards which must be met for any product seeking to be approved for use within any of TxDOT's construction or maintenance activities. The products that have been approved by TxDOT are also appropriate for general construction site stabilization. TxDOT maintains a web site at:

<http://www.dot.state.tx.us/insdtdot/orgchart/cmd/erosion/contents.htm>

which is continually updated as new products are evaluated. The following tables list applications and products approved by TxDOT as of February 2001.

## CLASS 1 "SLOPE PROTECTION"

### Type A - Slopes 1:3 or Flatter - Clay Soils:

|  |                                 |
|--|---------------------------------|
| Airtrol  | Landlok BonTerra EcoNet™ ENCS2  |
| Anti-wash/Geojute                              | Landlok BonTerra S1             |
| BioD-Mesh 60                                   | Landlok BonTerra S2             |
| Carthage Mills Veg Net                         | Landlok BonTerra CS2            |
| C-Jute   | Landlok BonTerra SFB12          |
| Contech Standard                               | Landlok 407GT                   |
| Contech Standard Plus                          | Landlok FRS 3112                |
| Contech Straw/Coconut Fiber Mat<br>w/Kraft Net | Landlok TRM 435                 |
| Contech C-35                                   | Miramat TM8                     |
| Conwed 3000                                    | North American Green S150       |
| Curlex I                                       | North American Green S75        |
| Curlex™-LT                                     | North American Green® S75 BN    |
| Earth Bound                                    | North American Green SC150      |
| EcoAegis™                                      | North American Green® S150 BN   |
| Econo-Jute                                     | Maccaferri MX287                |
| ECS Excelsior Blanket Standard                 | Pennzsuppress®                  |
| ECS High Velocity Straw Mat                    | Poplar Erosion Blanket          |
| ECS Standard Straw                             | Soil Guard                      |
| EnviroGuard Plus                               | Soil Saver                      |
| Formula 480 Liquid Clay                        | SuperGro                        |
| Futerra®                                       | Terra-Control®                  |
| Grass Mat                                      | TerraJute                       |
| Greenfix WSO72                                 | verdyol Ero-Mat                 |
| GeoTech TechMat™ SCKN                          | verdyol Excelsior High Velocity |
| Green Triangle Regular                         | verdyol Excelsior Standard      |
| Green Triangle Superior                        | Webtec Terraguard 44P           |
| Greenstreak Pec-Mat                            | Xcel Regular                    |
| Landlok BonTerra EcoNet™ ENS2                  | Xcel Superior                   |

**Type B - 1:3 or Flatter - Sandy Soils:**

|  |                               |
|--|-------------------------------|
| C-Jute   | Landlok®                      |
| Carthage Mills Veg Net                         | BonTerra®EcoNet™ENCs2™        |
| Contech Standard                               | Landlok® BonTerra®EcoNet™     |
| Contech Standard Plus                          | ENS2                          |
| Contech Straw/Coconut Fiber Mat<br>w/Kraft Net | Landlok FRS 3112              |
| Contech C-35                                   | Landlok 407GT                 |
| Curlex LT                                      | Landlok TRM 435               |
| Earth Bound                                    | Maccaferri MX287              |
| ECS Standard Straw                             | Miramat 1000                  |
| ECS Excelsior Blanket Standard                 | Miramat TM8                   |
| ECS High Velocity Straw Mat                    | North American Green S75      |
| EcoAegis™                                      | North American Green® S75 BN  |
| EnviroGuard Plus                               | North American Green S150     |
| Futerra®                                       | North American Green SC150    |
| Greenfix WSO72                                 | North American Green® S150 BN |
| Geojute Plus 1                                 | Poplar Erosion Blanket        |
| GeoTech TechMat™ SCKN                          | Soil Guard                    |
| Green Triangle Regular                         | Terra-Control®                |
| Green Triangle Superior                        | TerraJute                     |
| Landlok® BonTerra S1                           | verdyl Ero-Mat                |
| Landlok® BonTerra S2                           | verdyl Excelsior Standard     |
| Landlok® BonTerra CS2                          | Webtec Terraguard 44P         |
|  | Xcel Regular                  |
|  | Xcel Superior                 |

**Type C - Slopes Steeper than 1:3 - Clay Soils:**

|  |                                  |
|--|----------------------------------|
| Airtrol  | Landlok® BonTerra S2             |
| Anti-Wash/Geojute                              | Landlok BonTerra CS2             |
| Carthage Mills Veg Net                         | Landlok® BonTerra SFB12          |
| C-Jute   | Landlok 407GT                    |
| Contech Standard Plus                          | Landlok FRS 3112                 |
| Contech Straw/Coconut Fiber Mat<br>w/Kraft Net | Landlok TRM 435                  |
| Contech C-35                                   | Maccaferri MX287                 |
| Conwed 3000                                    | Miramat TM8                      |
| Curlex I                                       | North American Green S150        |
| Earth Bound                                    | North American Green S75         |
| Econo Jute                                     | North American Green SC150       |
| ECS High Velocity Straw Mat                    | North American Green® S150 BN    |
| ECS Standard Straw                             | Pennzsuppress®                   |
| EnviroGuard Plus                               | Poplar Erosion Blanket           |
| Formula 480 Liquid Clay                        | Soil Guard                       |
| Futerra®                                       | Soil Saver                       |
| Greenfix WSO72                                 | SuperGro                         |
| Green Triangle Superior                        | TerraJute                        |
| GeoTech TechMat™ SCKN                          | verdylol Excelsior High Velocity |
| Greenstreak Pec-Mat                            | Webtec Terraguard 44P            |
| Landlok® BonTerra® EcoNet™ ENCS2               | Xcel Superior                    |

**Type D - Slopes Steeper than 1:3 - Sandy Soils:**

|  |                               |
|--|-------------------------------|
| C-Jute   | Landlok® BonTerra CS2         |
| Carghage Mills Veg Net                         | Landlok®                      |
| Contech Standard Plus                          | BonTerra®EcoNet™ENCs2™        |
| Contech Straw/Coconut Fiber Mat<br>w/Kraft Net | Landlok 407GT                 |
| Contech C-35                                   | Landlok FRS 3112              |
| Curlex I                                       | Landlok TRM 435               |
| ECS High Velocity Straw Mat                    | Maccaferri MX287              |
| ECS Standard Straw                             | Miramat 1000                  |
| EnviroGuard Plus                               | Miramat TM8                   |
| Futerra®                                       | North American Green S150     |
| Greenfix WSO72                                 | North American Green SC150    |
| Geojute Plus 1                                 | North American Green® S150 BN |
| GeoTech TechMat™ SCKN                          | Soil Guard                    |
| Green Triangle Superior                        | TerraJute                     |
| Landlok® BonTerra S2                           | Webtec Terraguard 44P         |
|  | Xcel Superior                 |

## CLASS 2 - "FLEXIBLE CHANNEL LINER"

### **Type E - Shear Stress Range 0 - 96 Pascal (0 - 2 Pounds Per Square Foot):**

|                                 |                                 |
|---------------------------------|---------------------------------|
| Contech TRM C-45                | Koirmat™ 700                    |
| Contech C-35                    | Landlok® BonTerra® C2           |
| Contech C50                     | Landlok® BonTerra® CP2          |
| Contech Coconut/Poly Fiber Mat  | Landlok® BonTerra® EcoNet™      |
| Contech Coconut Mat w/Kraft Net | ENC2                            |
| Curlex® II Stitched             | Landlok® BonTerra® SFB™         |
| Curlex® III Stitched            | Landlok® BonTerra SFB12         |
| Curlex® Channel Enforcer 1      | Landlok TRM 435                 |
| Curlex® Channel Enforcer II     | Landlok TRM 450                 |
| Earth-Lock                      | Landlok TRM 1050                |
| Earth-Lock II                   | Landlok TRM 1060                |
| ECS High Impact Excelsior       | Maccaferri MX287                |
| ECS Standard Excelsior          | Miramat TM8                     |
| ECS High Velocity Straw Mat     | Multimat 100                    |
| Enkamat 7018                    | North American Green C125 BN    |
| Enkamat 7020                    | North American Green C350 Three |
| Enkamat Composite 30            | Phase                           |
| Enkamat Composite NPK**         | North American Green SC150 BN   |
| Enviromat                       | North American Green S350       |
| Geotech TechMat™ CP 3-D         | North American Green® P350      |
| Geotech TechMat™ CKN            | North American Green S150       |
| Greenfix CFO 72RP **            | Pyramat®                        |
| Greenfix CFO 72RR               | Webtec Terraguard 44P           |
| Greenstreak Pec-Mat             | Webtec Terraguard 45P           |
|                                 | Xcel PP-5                       |

**Type F - Shear Stress Range 0 - 192 Pascal (0 - 4 Pounds Per Square Foot):**

|                                 |  |
|---------------------------------|--|
| Curlex® II Stitched             | Koirmat™ 700                             |
| Curlex® III Stitched            | Landlok® BonTerra® C2                    |
| Curlex® Channel Enforcer 1      | Landlok® BonTerra® CP2                   |
| Curlex® Channel Enforcer II     | Landlok® BonTerra® EcoNet™               |
| Contech C50                     | ENC2                                     |
| Contech TRM C-45                | Landlok BonTerra® SFB™                   |
| Contech C-35                    | Landlok BonTerra SFB12                   |
| Contech Coconut/Poly Fiber Mat  | Landlok TRM 435                          |
| Contech Coconut Mat w/Kraft Net | Landlok TRM 450                          |
| Earth-Lock                      | Landlok TRM 1050                         |
| Earth-Lock II                   | Landlok TRM 1060                         |
| ECS High Impact Excelsior       | Maccaferri MX287                         |
| ECS High Velocity Straw Mat     | Miramat TM8                              |
| ECS Standard Excelsior          | Multimat 100                             |
| Enkamat 7018                    | North American Green C125 BN             |
| Enkamat Composite 30            | North American Green C350 Three<br>Phase |
| Enkamat Composite NPK **        | North American Green SC150 BN            |
| Enkamat Composite P/T**         | North American Green S350                |
| Enviromat                       | North American Green® P350               |
| Geotech TechMat™ CP 3-D         | North American Green S150                |
| Geotech TechMat™ CKN            | Pyramat®                                 |
| Greenfix CFO 72RP **            | Webtec Terraguard 44P                    |
| Greenfix CFO 72RR               | Webtec Terraguard 45P                    |
| Greenstreak Pec-Mat             | Xcel PP-5                                |

**Type G - Shear Stress Range 0 - 287 Pascal (0 - 6 Pounds Per Square Foot):**

|                                |                                 |
|--------------------------------|---------------------------------|
| Contech TRM C-45               | Koirmat™ 700                    |
| Contech C-35                   | Landlok® BonTerra® CP2          |
| Contech C50                    | Landlok® BonTerra® SFB™         |
| Contech Coconut/Poly Fiber Mat | Landlok® BonTerra SFB12         |
| Curlex® III Stitched           | Landlok TRM 1050                |
| Curlex® Channel Enforcer II    | Landlok TRM 1060                |
| Earth-Lock                     | Landlok TRM 435                 |
| Earth-Lock II                  | Landlok TRM 450                 |
| Enkamat 7018                   | North American Green C350 Three |
| Enkamat Composite 30           | Phase                           |
| Geotech TechMat™ CP 3-D        | North American Green S350       |
| Greenstreak Pec-Mat            | North American Green® P350      |
|                                | Pyramat®                        |
|                                | Webtec Terraguard 44P           |
|                                | Webtec Terraguard 45P           |

**Type H - Shear Stress Range 0 - 383 Pascal (0 - 8 Pounds Per Square Foot):**

|                                |                                 |
|--------------------------------|---------------------------------|
| Contech TRM C-45               | Landlok TRM 1060                |
| Contech C-35                   | North American Green C350 Three |
| Contech C50                    | Phase                           |
| Contech Coconut/Poly Fiber Mat | North American Green S350       |
| Curlex® III Stitched           | North American Green® P350      |
| Geotech TechMat™ CP 3-D        | Pyramat®                        |
| <i>Landlok® BonTerra SFB12</i> | Webtec Terraguard 44P           |
| Landlok TRM 435                | Webtec Terraguard 45P           |
| Landlok TRM 450                |                                 |
| Landlok TRM 1050               |                                 |



## **"SEEDING FOR EROSION CONTROL"**

### **Cellulose Fiber Mulches**

#### **Clay or Tight Soils:**

Agri-Fiber  
American Fiber Mulch  
American Fiber Mulch (with Hydro-Stick)  
Conwed Hydro Mulch  
Enviro-Gro  
Evercycle™ Hydro-Mulch  
Excel Fibermulch II (with Exact-Tac)  
Lay-Low Mulch  
Oasis Fiber Mulch  
Pennzsuppress®  
Pro Mat  
Pro Mat (with RMBplus)  
Pro Mat XL  
Second Nature Regenerated Paper Fiber Mulch  
Silva Fiber Plus

#### **Sandy or Loose Soils:**

American Fiber Mulch  
American Fiber Mulch (with Hydro-Stick)  
American Fiber Mulch with Stick Plus  
Conwed Hydro Mulch  
Enviro-Gro  
Evercycle™ Hydro-Mulch  
Excel Fibermulch II (with Exact-Tac)  
Lay-Low Mulch  
Oasis Fiber Mulch  
Pennzsuppress®  
Pro Mat  
Pro Mat (with RMBplus)  
Pro Mat XL  
Second Nature Regenerated Paper Fiber Mulch

**Installation:**

Proper installation of blankets and matting is necessary for these materials to function as intended. They should always be installed in accordance with the manufacturer's recommendations. Proper anchoring of the material and preparation of the soil are two of the most important aspects of installation. Typical anchoring methods are shown in Figure 1-20 and Figure 1-21.

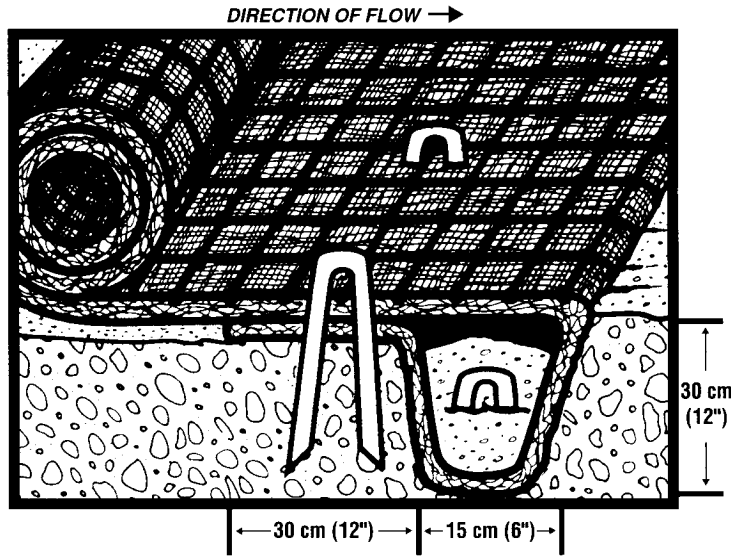

**Figure 1-20 Initial Anchor Trench for Blankets and Mats**

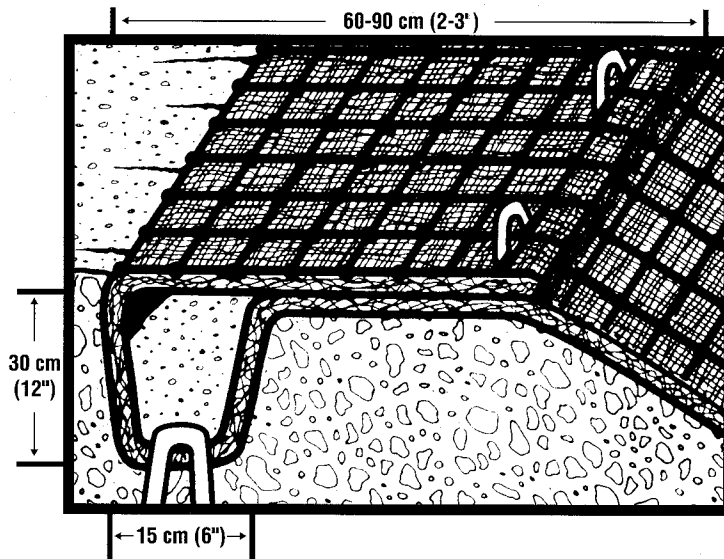

**Figure 1-21 Terminal Anchor Trench for Blankets and Mats**

### *Soil Preparation*

- (1) After site has been shaped and graded to approved design, prepare a friable seed bed relatively free from clods and rocks more than 1.5 inches in diameter and any foreign material that will prevent contact of the protective mat with the soil surface.
- (2) Fertilize and seed in accordance with seeding or other type of planting plan.
- (3) The protective matting can be laid over sprigged areas where small grass plants have been planted. Where ground covers are to be planted, lay the protective matting first and then plant through matting according to design of planting.

### *Erosion Stops*

- (1) Erosion stops should extend beyond the channel liner to full design cross-section of the channel to check any rills that might form outside the channel lining.
- (2) The trench may be dug with a spade or a mechanical trencher, making sure that the down slope face of the trench is flat; it should be uniform and perpendicular to line of flow to permit proper placement and stapling of the matting.
- (3) The erosion stop should be deep enough to penetrate solid material or below level of ruling in sandy soils. In general, erosion stops will vary from 6 to 12 inches in depth.
- (4) The erosion stop mat should be wide enough to allow a minimum of 2 inch turnover at bottom of trench for stapling, while maintaining the top edge flush with channel surface.
- (5) Tamp backfill firmly and to a uniform gradient of channel.

### Final Check:

- Make sure matting is uniformly in contact with the soil.
- All lap joints are secure.
- All staples are flush with the ground.
- All disturbed areas seeded.

### **Inspection and Maintenance Guidelines:**

- (1) Blankets and matting should be inspected weekly and after each rain event to locate and repair any damage. Apply new material if necessary to restore function.

### 1.3.10 Hydraulic Mulch

Hydraulic mulch consists of applying a mixture of shredded wood fiber or a hydraulic matrix, and a stabilizing emulsion or tackifier with hydro-mulching equipment, which temporarily protects exposed soil from erosion by raindrop impact or wind. Hydraulic mulch is suitable for soil disturbed areas requiring temporary protection until permanent stabilization is established, and disturbed areas that will be re-disturbed following an extended period of inactivity. It is not appropriate for slopes of 3:1 or steeper or for use in channels.

Wood fiber hydraulic mulches are generally short lived and need 24 hours to dry before rainfall occurs to be effective. May require a second application in order to remain effective for an entire rainy season.

#### **Materials:**

*Hydraulic Mulches:* Wood fiber mulch can be applied alone or as a component of hydraulic matrices. Wood fiber applied alone is typically applied at the rate of 2,000 to 4,000 lb/acre. Wood fiber mulch is manufactured from wood or wood waste from lumber mills or from urban sources.

*Hydraulic Matrices:* Hydraulic matrices include a mixture of wood fiber and acrylic polymer or other tackifier as binder. Apply as a liquid slurry using a hydraulic application machine (i.e., hydro seeder) at the following minimum rates, or as specified by the manufacturer to achieve complete coverage of the target area: 2,000 to 4,000 lb/acre wood fiber mulch, and 5 to 10% (by weight) of tackifier (acrylic copolymer, guar, psyllium, etc.)

*Bonded Fiber Matrix:* Bonded fiber matrix (BFM) is a hydraulically applied system of fibers and adhesives that upon drying forms an erosion resistant blanket that promotes vegetation, and prevents soil erosion. BFMs are typically applied at rates from 3,000 lb/acre to 4,000 lb/acre based on the manufacturer's recommendation. A biodegradable BFM is composed of materials that are 100% biodegradable. The binder in the BFM should also be biodegradable and should not dissolve or disperse upon re-wetting. Typically, biodegradable BFMs should not be applied immediately before, during or immediately after rainfall if the soil is saturated. Depending on the product, BFMs typically require 12 to 24 hours to dry and become effective.

**Installation:**

- (1) Prior to application, roughen embankment and fill areas by rolling with a crimping or punching type roller or by track walking. Track walking shall only be used where other methods are impractical.
- (2) To be effective, hydraulic matrices require 24 hours to dry before rainfall occurs.
- (3) Avoid mulch over spray onto roads, sidewalks, drainage channels, existing vegetation, etc.

**Inspection and Maintenance Guidelines:**

- (1) Mulched areas should be inspected weekly and after each rain event to locate and repair any damage.
- (2) Areas damaged by storms or normal construction activities should be regraded and hydraulic mulch reapplied as soon as practical.

**1.3.11 Sod**

Sod is appropriate for disturbed areas which require immediate vegetative covers, or where sodding is preferred to other means of grass establishment. Locations particularly suited to stabilization with sod are waterways carrying intermittent flow, areas around drop inlets or in grassed swales, and residential or commercial lawns where quick use or aesthetics are factors.

The advantages of properly installed sod include:

- Immediate erosion control.
- An instant green surface with no dust or mud.
- Nearly year-round establishment capability.
- Less chance of failure than seed.
- Freedom from weeds.
- Quick use of the sodded surface.
- The option of buying a quality-controlled product with predictable results.

It is initially more costly to install sod than to seed. However, this cost is justified in places where sod can perform better than seed in controlling erosion. In swales and waterways where concentrated flow will occur, properly pegged sod is preferable to seed because there is no lag time between installation and the time when the channel is protected by vegetation. Drop inlets, which will be placed in grassed areas, can be kept

free of sediment, and the grade immediately around the inlet can be maintained, by framing the inlet with sod strips.

Sod can be laid during times of the year when seeded grass may fail, so long as there is adequate water available for irrigation in the early weeks. Ground preparation and proper maintenance are as important with sod as with seed. Sod is composed of living plants and those plants must receive adequate care in order to provide vegetative stabilization on a disturbed area.

**Materials:**

- (1) Sod should be machine cut at a uniform soil thickness of  $\frac{3}{4}$  inch ( $\pm \frac{1}{4}$  inch) at the time of cutting. This thickness should exclude shoot growth and thatch.
- (2) Pieces of sod should be cut to the supplier's standard width and length, with a maximum allowable deviation in any dimension of 5%. Torn or uneven pads should not be acceptable.
- (3) Standard size sections of sod should be strong enough to support their own weight and retain their size and shape when suspended from a firm grasp on one end of the section.
- (4) Sod should be harvested, delivered, and installed within a period of 36 hours.

**Site Preparation:**

- (1) Prior to soil preparation, areas to be sodded should be brought to final grade in accordance with the approved plan.
- (2) The surface should be cleared of all trash, debris and of all roots, brush, wire, grade stakes and other objects that would interfere with planting, fertilizing or maintenance operations.
- (3) Fertilize according to soil tests. Fertilizer needs can be determined by a soil testing laboratory or regional recommendations can be made by county agricultural extension agents. Fertilizer should be worked into the soil to a depth of 3 inches with a disc, springtooth harrow or other suitable equipment. On sloping land, the final harrowing or discing operation should be on the contour.

**General Installation (VA Dept of Conservation, 1992):**

- (1) Sod should not be cut or laid in excessively wet or dry weather. Sod also should not be laid on soil surfaces that are frozen.
- (2) During periods of high temperature, the soil should be lightly irrigated immediately prior to laying the sod, to cool the soil and reduce root burning and dieback.
- (3) The first row of sod should be laid in a straight line with subsequent rows placed parallel to and butting tightly against each other. Lateral joints should be staggered to promote more uniform growth and strength. Care should be exercised to ensure that sod is not stretched or overlapped and that all joints are butted tight in order to prevent voids which would cause drying of the roots (see Figure 1-22).
- (4) On slopes 3:1 or greater, or wherever erosion may be a problem, sod should be laid with staggered joints and secured by stapling or other approved methods. Sod should be installed with the length perpendicular to the slope (on the contour).
- (5) As sodding of clearly defined areas is completed, sod should be rolled or tamped to provide firm contact between roots and soil.
- (6) After rolling, sod should be irrigated to a depth sufficient that the underside of the sod pad and the soil 4 inches below the sod is thoroughly wet.
- (7) Until such time a good root system becomes developed, in the absence of adequate rainfall, watering should be performed as often as necessary to maintain moist soil to a depth of at least 4 inches.
- (8) The first mowing should not be attempted until the sod is firmly rooted, usually 2-3 weeks. Not more than one third of the grass leaf should be removed at any one cutting.

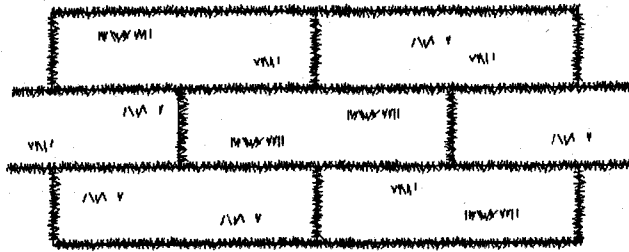

LAY SOD IN A STAGGERED PATTERN. BUTT THE STRIPS TIGHTLY AGAINST EACH OTHER. DO NOT LEAVE SPACES AND DO NOT OVERLAP. A SHARPENED MASON'S TROWEL IS A HANDY TOOL FOR TUCKING DOWN THE ENDS AND TRIMMING PIECES.

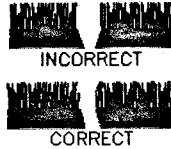

BUTTING - ANGLED ENDS CAUSED BY THE AUTO-MATIC SOD CUTTER MUST BE MATCHED CORRECTLY.



ROLL SOD IMMEDIATELY TO ACHIEVE FIRM CONTACT WITH THE SOIL.

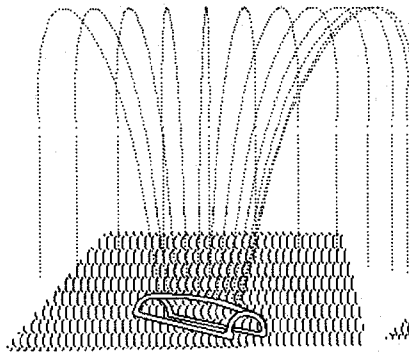

WATER TO A DEPTH OF 4" AS NEEDED. WATER WELL AS SOON AS THE SOD IS LAID.

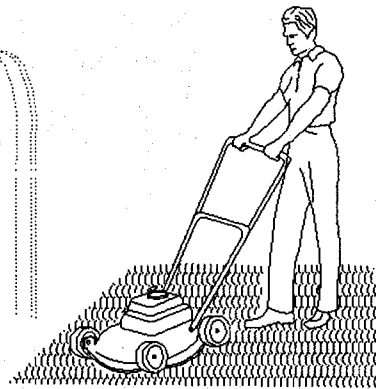

MOW WHEN THE SOD IS ESTABLISHED - IN 2-3 WEEKS. SET THE MOWER HIGH (2"-3").

### APPEARANCE OF GOOD SOD

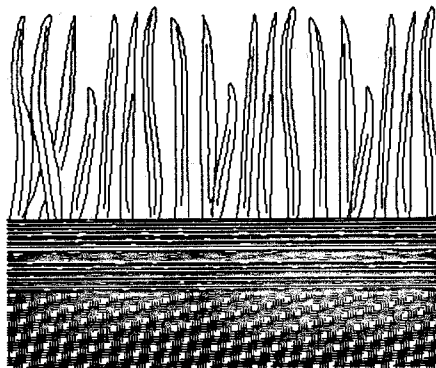

SHOOTS OR GRASS BLADES. GRASS SHOULD BE GREEN AND HEALTHY, MOWED AT A 2"-3" CUTTING HEIGHT.

THATCH - GRASS CLIPPINGS AND DEAD LEAVES, UP TO 1/2" THICK.

ROOT ZONE - SOIL AND ROOTS. SHOULD BE 1/2"-3/4" THICK, WITH DENSE ROOT MAT FOR STRENGTH.

Figure 1-22 Proper Sod Installation Techniques (VA Dept. of Conservation, 1992)



**Installation in Channels:**

- (1) Sod strips in waterways should be laid perpendicular to the direction of flow. Care should be taken to butt ends of strips tightly (see Figure 1-23).
- (2) After rolling or tamping, sod should be pegged or stapled to resist washout during the establishment period. Mesh or other netting may be pegged over the sod for extra protection in critical areas.

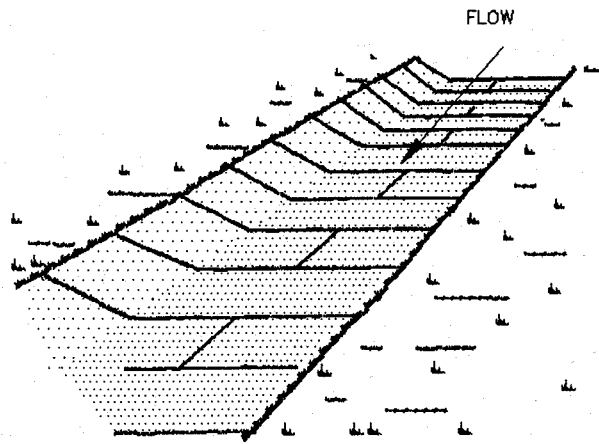

LAY SOD ACROSS THE DIRECTION OF FLOW.

USE PEGS OR STAPLES TO FASTEN SOD FIRMLY - AT THE ENDS OF STRIPS AND IN THE CENTER, OR EVERY 3-4 FEET IF THE STRIPS ARE LONG. WHEN READY TO MOW, DRIVE PEGS OR STAPLES FLUSH WITH THE GROUND.

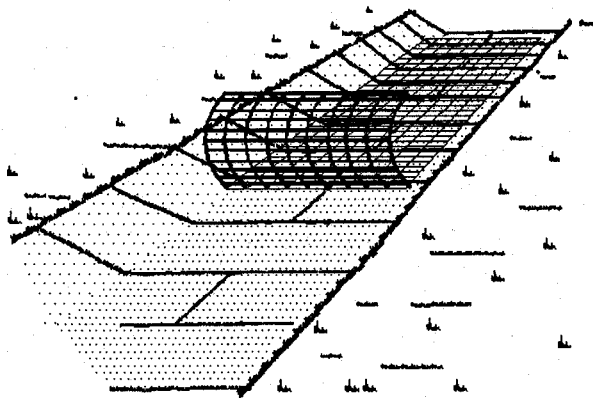
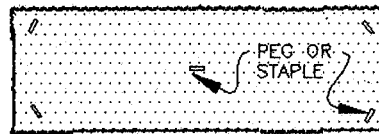
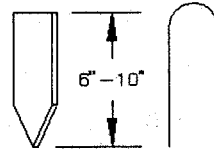

IN CRITICAL AREAS, SECURE SOD WITH NETTING. USE STAPLES.

Figure 1-23 Installation of Sod in a Channel (VA Dept. of Conservation, 1992)

**Inspection and Maintenance Guidelines:**

- (3) Sod should be inspected weekly and after each rain event to locate and repair any damage.
- (4) Damage from storms or normal construction activities such as tire ruts or disturbance of swale stabilization should be repaired as soon as practical.

### 1.3.12 Dust Control

The purpose of dust control is to prevent blowing and movement of dust from exposed soil surfaces, reduce on and off-site damage, health hazards and improve traffic safety. This practice is applicable to areas subject to dust blowing and movement where on and off-site damage is likely without treatment.

Construction activities inevitably result in the exposure and disturbance of soil. Fugitive dust is emitted both during the activities (i.e., excavation demolition, vehicle traffic, human activity) and as a result of wind erosion over the exposed earth surfaces. Large quantities of dust are typically generated in ‘heavy’ construction activities, such as road and street construction and subdivision, commercial or industrial development, which involve disturbance of significant areas of the soil surface. Research on construction sites has established an average dust emission rate of 1.2 tons/acre/month for active construction (VA Dept of Conservation, 1992). Earth moving activities comprise the major source of construction dust emissions, but traffic and general disturbance of the soil also generate significant dust emissions.

#### **Temporary Methods:**

- (1) Vegetative Cover – See Section 1.3.8.
- (2) Mulches – See Section 1.3.10 – Chemical mulch binders may be used to bind mulch material. Commercial binders should be used according to manufacturer’s recommendations.
- (3) Commercially available dust suppressors if applied in accordance with the manufacturers’ directions
- (4) Tillage – to roughen surface and bring clods to the surface. This is an emergency measure that should be used before soil blowing starts. Begin plowing on windward side of site. Chisel-type plows spaced about 12 inches apart, spring-toothed harrows and similar plows are examples of equipment that may produce the desired effect.
- (5) Irrigation – Site is sprinkled with water until the surface is moist. Repeat as needed. Irrigation can be particularly effective for controlling dust during trenching operations. A dedicated water truck placed next to the trencher and using a “pulse” fog pattern applied to the discharge belt can effectively control dust. This method is more effective than spraying the ground ahead of the trencher or the trench itself as it is being dug.
- (6) Barriers – Solid board fences, snow fences, burlap fences, crate walls, bales of hay and similar materials can be used to control air currents and soil blowing.

Barriers placed at right angles to prevailing currents at intervals of about 15 times their height are effective in controlling soil blowing.

**Permanent Methods:**

- (1) Permanent Vegetation – trees or large shrubs may afford valuable protection if left in place.
- (2) Topsoil – Covering with less erosive soil material.
- (3) Stone – Cover surface with crushed stone or coarse gravel.

**Inspection and Maintenance Guidelines:**

- (1) When dust is evident during dry weather, reapply dust control BMPs.

## ***1.4 Temporary Sediment Control BMPs***

### **1.4.1 General Guidelines**

Construction activities normally result in disturbance on the site due to grading operations, clearing and other activities. Erosion will occur in the disturbed areas and BMPs should be used to contain the sediment transported by stormwater runoff. Although the names of many controls suggest that filtration is an important component of sediment removal, almost all reduction in sediment load is the result of particle settling under relatively quiescent conditions. Consequently, sediment barriers, such as silt fences and rock berms, should be designed and installed as temporary (although leaky) dams.

When viewed as temporary dams, it is easier to see the importance of installing these devices along the contour or with a constant top elevation to prevent concentrating the runoff at the lowest spot in the barrier. Concentrating the runoff in this fashion can result in more erosion than if no barrier was installed at all. Therefore, great care should be taken in the placement and installation of these types of controls.

For larger areas or where effective installation of sediment barriers is not an option, sediment traps and sediment basins should be used to control sediment in runoff. These devices are essentially larger, more permanent dams that temporarily detain stormwater runoff.

All of the sediment control BMPs are potentially very effective for removing sediment from stormwater runoff when properly maintained and installed. However, this potential is often squandered. Casual observation of many active construction sites reveals silt fences that are torn or damaged by equipment, evidence of stormwater bypass, or controls installed in inappropriate locations (i.e., silt fences used in channels). In these cases, significant funds are expended for little in the way of water quality protection. Consequently, proper installation and maintenance should form a key component of any temporary sediment control plan.

A list of the temporary sediment controls and their appropriate siting criteria are contained in Table 1-5. More detailed guidance on siting and maintenance are contained in the subsequent sections. Note that hay bales are no longer considered an effective sediment control measure. Compost amended soils can be used to promote vegetation growth, but they are not considered a sediment control technology. Compost berms for sediment control are considered to be an experimental technology and should not be used in the areas covered by the Edwards Rules.

**Table 1-5 Guidelines for Selection of Sediment Control BMPs**

| <b>Control Type</b>      | <b>Applications</b>  | <b>Drainage Area</b>     | <b>Slope</b> |
|--------------------------|--|--------------------------|--------------|
| Construction Exit        | Should be used at all designated access points.  | NA                       | NA           |
| Silt Fence (interior)    | Areas of minor sheet flow.   | < ¼ acre/100 ft of fence | < 20%        |
| Silt Fence (exterior)    | Down slope borders of site; up slope border is necessary to divert offsite drainage. For larger areas use diversion swale or berm. | < ¼ acre/100 ft of fence | < 20%        |
| Triangular Filter Dike   | Areas within site requiring frequent access.   | < 1 acre                 | < 10%        |
| Rock Berm                | Drainage swales and ditches with and below site.   | < 5 acres                | < 30%        |
| High Service Rock Berm   | Around sensitive features, high flow areas within and below site.  | < 5 acres                | < 30%        |
| Brush Berm               | Small areas of sheet flow  | < 2 acres                | < 20%        |
| Sand Bag Berm            | For construction activities in streambeds.   | 5-10 acres               | <15%         |
| Vegetative Buffer Strips | On floodplains, next to wetlands, along stream banks, and on steep slopes.   | NA                       | NA           |
| Inlet Protection         | Prevent sediment from entering storm drain system.   | < 1 acre                 | NA           |
| Sediment Trap            | Used where flows concentrated in a swale or channel  | 1-5 acres                | NA           |
| Sediment Basin           | Appropriate for large disturbed areas  | 5 – 100 acres            | NA           |
| Filter Rolls             | On slopes to interrupt slope   | < 1 acre                 | <30%         |
| Dewatering Operations    | Used to remove groundwater or accumulated stormwater from excavations  | NA                       | NA           |
| Spill Prevention         | Used on all sites to reduce spills   | NA                       | NA           |
| Utility Line Crossings   | Crossings of drainage ways and creeks  | >40 acres                | NA           |
| Concrete Washout         | Use on all concrete pouring operations   | NA                       | NA           |

### 1.4.2 Temporary Construction Entrance/Exit

The purpose of a temporary gravel construction entrance is to provide a stable entrance/exit condition from the construction site and keep mud and sediment off public roads. A stabilized construction entrance is a stabilized pad of crushed stone located at any point traffic will be entering or leaving the construction site from a public right-of-way, street, alley, sidewalk or parking area. The purpose of a stabilized construction entrance is to reduce or eliminate the tracking or flowing of sediment onto public rights-of-way. This practice should be used at all points of construction ingress and egress. Schematic diagrams of a construction entrance/exit are shown in Figure 1-24 and Figure 1-25.

Excessive amounts of mud can also present a safety hazard to roadway users. To minimize the amount of sediment loss to nearby roads, access to the construction site should be limited to as few points as possible and vegetation around the perimeter should be protected where access is not necessary. A rock stabilized construction entrance should be used at all designated access points.

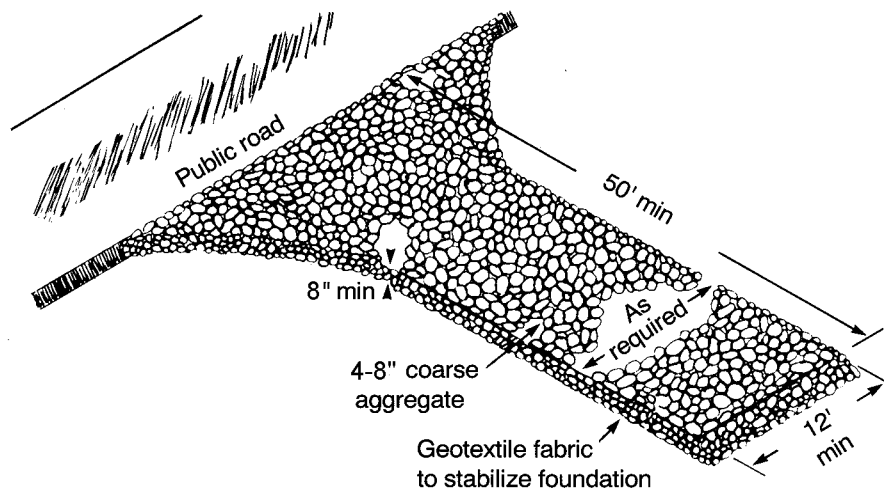

Figure 1-24 Schematic of Temporary Construction Entrance/Exit (after NC, 1993)

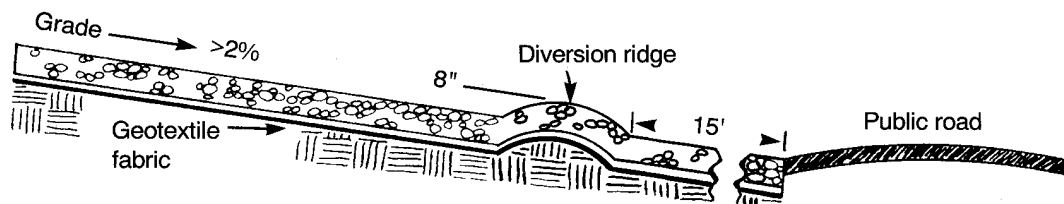

Figure 1-25 Cross-section of a Construction Entrance/Exit (NC, 1993)

**Materials:**

- (1) The aggregate should consist of 4 to 8 inch washed stone over a stable foundation as specified in the plan.
- (2) The aggregate should be placed with a minimum thickness of 8 inches.
- (3) The geotextile fabric should be designed specifically for use as a soil filtration media with an approximate weight of 6 oz/yd<sup>2</sup>, a mullen burst rating of 140 lb/in<sup>2</sup>, and an equivalent opening size greater than a number 50 sieve.
- (4) If a washing facility is required, a level area with a minimum of 4 inch diameter washed stone or commercial rack should be included in the plans. Divert wastewater to a sediment trap or basin.

**Installation:** (North Carolina, 1993)

- (1) Avoid curves on public roads and steep slopes. Remove vegetation and other objectionable material from the foundation area. Grade crown foundation for positive drainage.
- (2) The minimum width of the entrance/exit should be 12 feet or the full width of exit roadway, whichever is greater.
- (3) The construction entrance should be at least 50 feet long.
- (4) If the slope toward the road exceeds 2%, construct a ridge, 6 to 8 inches high with 3:1 (H:V) side slopes, across the foundation approximately 15 feet from the entrance to divert runoff away from the public road.
- (5) Place geotextile fabric and grade foundation to improve stability, especially where wet conditions are anticipated.
- (6) Place stone to dimensions and grade shown on plans. Leave surface smooth and slope for drainage.
- (7) Divert all surface runoff and drainage from the stone pad to a sediment trap or basin.
- (8) Install pipe under pad as needed to maintain proper public road drainage.



### **Common trouble points**

- (1) Inadequate runoff control – sediment washes onto public road.
- (2) Stone too small or geotextile fabric absent, results in muddy condition as stone is pressed into soil.
- (3) Pad too short for heavy construction traffic – extend pad beyond the minimum 50 foot length as necessary.
- (4) Pad not flared sufficiently at road surface, results in mud being tracked on to road and possible damage to road edge.
- (5) Unstable foundation – use geotextile fabric under pad and/or improve foundation drainage.

### **Inspection and Maintenance Guidelines:**

- (1) The entrance should be maintained in a condition, which will prevent tracking or flowing of sediment onto public rights-of-way. This may require periodic top dressing with additional stone as conditions demand and repair and/or cleanout of any measures used to trap sediment.
- (2) All sediment spilled, dropped, washed or tracked onto public rights-of-way should be removed immediately by contractor.
- (3) When necessary, wheels should be cleaned to remove sediment prior to entrance onto public right-of-way.
- (4) When washing is required, it should be done on an area stabilized with crushed stone that drains into an approved sediment trap or sediment basin.
- (5) All sediment should be prevented from entering any storm drain, ditch or water course by using approved methods.

### 1.4.3 Silt Fence

A silt fence is a barrier consisting of geotextile fabric supported by metal posts to prevent soil and sediment loss from a site. When properly used, silt fences can be highly effective at controlling sediment from disturbed areas. They cause runoff to pond, allowing heavier solids to settle out. If not properly installed, silt fences are not likely to be effective. A schematic illustration of a silt fence is shown in Figure 1-26.

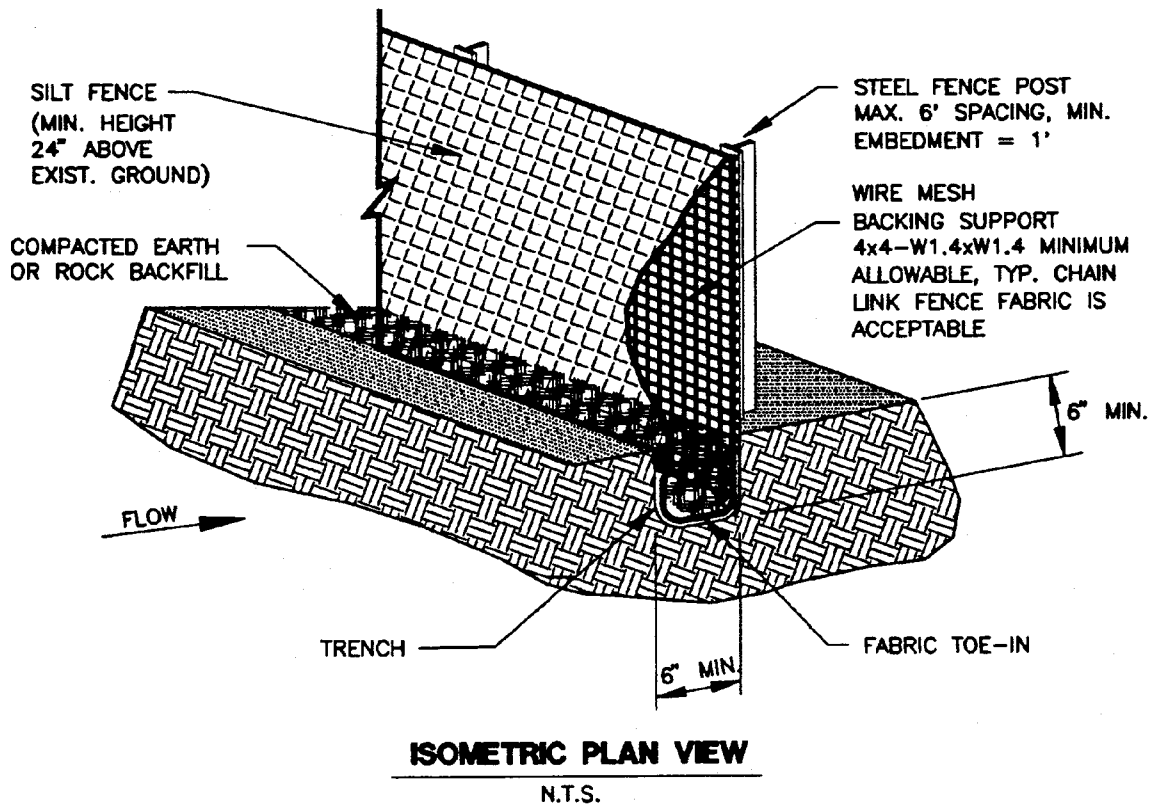

**Figure 1-26 Schematic of a Silt Fence Installation (NCTCOG, 1993b)**

The purpose of a silt fence is to intercept and detain water-borne sediment from unprotected areas of a limited extent. Silt fence is used during the period of construction near the perimeter of a disturbed area to intercept sediment while allowing water to percolate through. This fence should remain in place until the disturbed area is permanently stabilized. Silt fence should not be used where there is a concentration of water in a channel or drainage way. If concentrated flow occurs after installation, corrective action must be taken such as placing a rock berm in the areas of concentrated flow.

Silt fencing within the site may be temporarily moved during the day to allow construction activity provided it is replaced and properly anchored to the ground at the end of the day. Silt fences on the perimeter of the site or around drainage ways should not be moved at any time.

**Materials:**

- (1) Silt fence material should be polypropylene, polyethylene or polyamide woven or nonwoven fabric. The fabric width should be 36 inches, with a minimum unit weight of 4.5 oz/yd, mullen burst strength exceeding 190 lb/in<sup>2</sup>, ultraviolet stability exceeding 70%, and minimum apparent opening size of U.S. Sieve No. 30.
- (2) Fence posts should be made of hot rolled steel, at least 4 feet long with Tee or Y-bar cross section, surface painted or galvanized, minimum nominal weight 1.25 lb/ft<sup>2</sup>, and Brindell hardness exceeding 140.
- (3) Woven wire backing to support the fabric should be galvanized 2" x 4" welded wire, 12 gauge minimum.

**Installation:**

- (1) Steel posts, which support the silt fence, should be installed on a slight angle toward the anticipated runoff source. Post must be embedded a minimum of 1-foot deep and spaced not more than 8 feet on center. Where water concentrates, the maximum spacing should be 6 feet.
- (2) Lay out fencing down-slope of disturbed area, following the contour as closely as possible. The fence should be sited so that the maximum drainage area is ¼ acre/100 feet of fence.
- (3) The toe of the silt fence should be trenched in with a spade or mechanical trencher, so that the down-slope face of the trench is flat and perpendicular to the line of flow. Where fence cannot be trenched in (e.g., pavement or rock outcrop), weight fabric flap with 3 inches of pea gravel on uphill side to prevent flow from seeping under fence.
- (4) The trench must be a minimum of 6 inches deep and 6 inches wide to allow for the silt fence fabric to be laid in the ground and backfilled with compacted material.
- (5) Silt fence should be securely fastened to each steel support post or to woven wire, which is in turn attached to the steel fence post. There should be a 3-foot overlap, securely fastened where ends of fabric meet.

- (6) Silt fence should be removed when the site is completely stabilized so as not to block or impede storm flow or drainage.

**Common Trouble Points:**

- (1) Fence not installed along the contour causing water to concentrate and flow over the fence.
- (2) Fabric not seated securely to ground (runoff passing under fence)
- (3) Fence not installed perpendicular to flow line (runoff escaping around sides)
- (4) Fence treating too large an area, or excessive channel flow (runoff overtops or collapses fence)

**Inspection and Maintenance Guidelines:**

- (1) Inspect all fencing weekly, and after any rainfall.
- (2) Remove sediment when buildup reaches 6 inches.
- (3) Replace any torn fabric or install a second line of fencing parallel to the torn section.
- (4) Replace or repair any sections crushed or collapsed in the course of construction activity. If a section of fence is obstructing vehicular access, consider relocating it to a spot where it will provide equal protection, but will not obstruct vehicles. A triangular filter dike may be preferable to a silt fence at common vehicle access points.
- (5) When construction is complete, the sediment should be disposed of in a manner that will not cause additional siltation and the prior location of the silt fence should be revegetated. The fence itself should be disposed of in an approved landfill.

#### 1.4.4 Triangular Sediment Filter Dikes

The purpose of a triangular sediment filter dike (Figure 1-27) is to intercept and detain water-borne sediment from unprotected areas of limited extent. The triangular sediment filter dike is used where there is no concentration of water in a channel or other drainage way above the barrier and the contributing drainage area is less than one acre. If the uphill slope above the dike exceeds 10%, the length of the slope above the dike should be less than 50 feet. If concentrated flow occurs after installation, corrective action should be taken such as placing rock berm in the areas of concentrated flow.

This measure is effective on paved areas where installation of silt fence is not possible or where vehicle access must be maintained. The advantage of these controls is the ease with which they can be moved to allow vehicle traffic, then reinstalled to maintain sediment control.

##### **Materials:**

- (1) Silt fence material should be polypropylene, polyethylene or polyamide woven or nonwoven fabric. The fabric width should be 36 inches, with a minimum unit weight of 4.5 oz/yd, mullen burst strength exceeding 190 lb/in<sup>2</sup>, ultraviolet stability exceeding 70%, and minimum apparent opening size of U.S. Sieve No. 30.
- (2) The dike structure should be 6 gauge 6" x 6" wire mesh folded into triangular form being eighteen (18) inches on each side.

##### **Installation:**

- (1) As shown in the diagram (Figure 1-27), the frame should be constructed of 6" x 6", 6 gauge welded wire mesh, 18 inches per side, and wrapped with geotextile fabric the same composition as that used for silt fences.
- (2) Filter fabric should lap over ends six (6) inches to cover dike to dike junction; each junction should be secured by shoat rings.
- (3) Position dike parallel to the contours, with the end of each section closely abutting the adjacent sections.
- (4) There are several options for fastening the filter dike to the ground as shown in Figure 1-27. The fabric skirt may be toed-in with 6 inches of compacted material, or 12 inches of the fabric skirt should extend uphill and be secured with a minimum of 3 inches of open graded rock, or with staples or nails. If these two options are not feasible the dike structure may be trenched in 4 inches.

- (5) Triangular sediment filter dikes should be installed across exposed slopes during construction with ends of the dike tied into existing grades to prevent failure and should intercept no more than one acre of runoff.
- (6) When moved to allow vehicular access, the dikes should be reinstated as soon as possible, but always at the end of the workday.

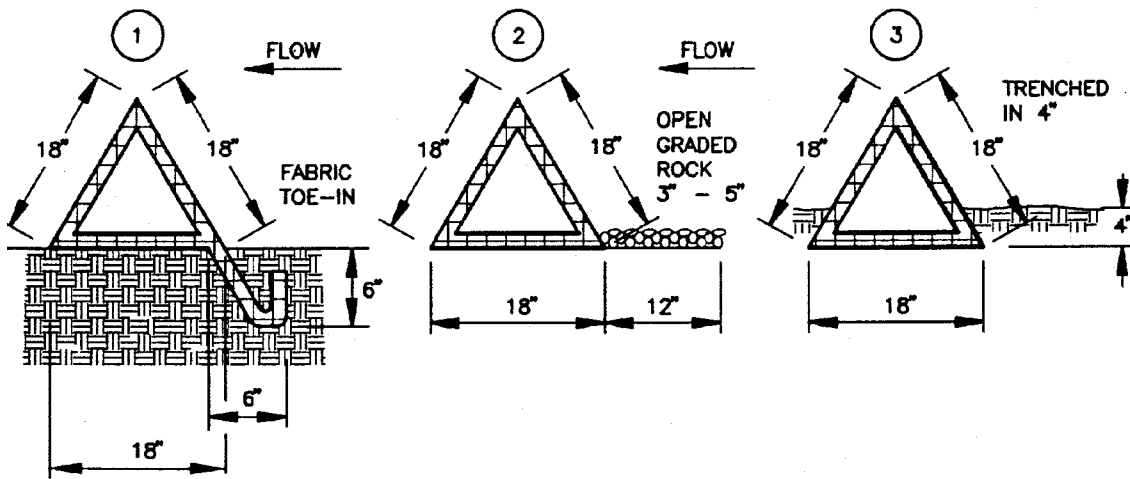

**CROSS SECTION OF INSTALLATION OPTIONS**

N.T.S.

- 1. TOE-IN 6" MIN
- 2. WEIGHTED W/ 3" - 5" OPEN GRADED ROCK
- 3. TRENCHED IN 4"

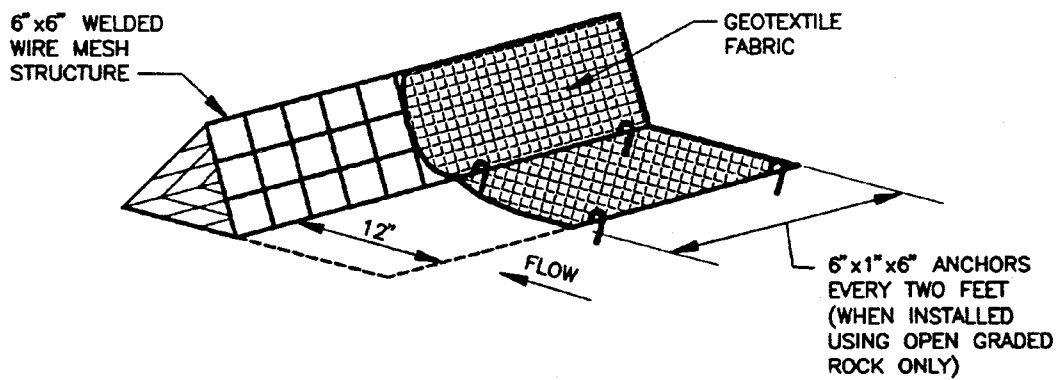

**ISOMETRIC PLAN VIEW**

N.T.S.

Figure 1-27 Schematic of a Triangular Filter Dike (NCTCOG, 1993)

**Common Trouble Points:**

- (1) Fabric skirt missing, too short, or not securely anchored (flows passing under dike).
- (2) Gap between adjacent dikes (runoff passing between dikes).
- (3) Dike not placed parallel to contour (runoff flowing around dike).

**Inspection and Maintenance Guidelines:**

- (1) Inspection should be made weekly or after each rainfall event and repair or replacement should be made promptly as needed by the contractor.
- (2) Inspect and realign dikes as needed to prevent gaps between sections.
- (3) Accumulated silt should be removed after each rainfall, and disposed of in a manner which will not cause additional siltation.
- (4) After the site is completely stabilized, the dikes and any remaining silt should be removed. Silt should be disposed of in a manner that will not contribute to additional siltation.

#### 1.4.5 Rock Berms

The purpose of a rock berm is to serve as a check dam in areas of concentrated flow, to intercept sediment-laden runoff, detain the sediment and release the water in sheet flow. The rock berm should be used when the contributing drainage area is less than 5 acres. Rock berms are used in areas where the volume of runoff is too great for a silt fence to contain. They are less effective for sediment removal than silt fences, particularly for fine particles, but are able to withstand higher flows than a silt fence. As such, rock berms are often used in areas of channel flows (ditches, gullies, etc.). Rock berms are most effective at reducing bed load in channels and should not be substituted for other erosion and sediment control measures farther up the watershed.

##### **Materials:**

- (1) The berm structure should be secured with a woven wire sheathing having maximum opening of 1 inch and a minimum wire diameter of 20 gauge galvanized and should be secured with shoat rings.
- (2) Clean, open graded 3- to 5-inch diameter rock should be used, except in areas where high velocities or large volumes of flow are expected, where 5- to 8-inch diameter rocks may be used.

##### **Installation:**

- (1) Lay out the woven wire sheathing perpendicular to the flow line. The sheathing should be 20 gauge woven wire mesh with 1 inch openings.
- (2) Berm should have a top width of 2 feet minimum with side slopes being 2:1 (H:V) or flatter.
- (3) Place the rock along the sheathing as shown in the diagram (Figure 1-28), to a height not less than 18".
- (4) Wrap the wire sheathing around the rock and secure with tie wire so that the ends of the sheathing overlap at least 2 inches, and the berm retains its shape when walked upon.
- (5) Berm should be built along the contour at zero percent grade or as near as possible.
- (6) The ends of the berm should be tied into existing upslope grade and the berm should be buried in a trench approximately 3 to 4 inches deep to prevent failure of the control.



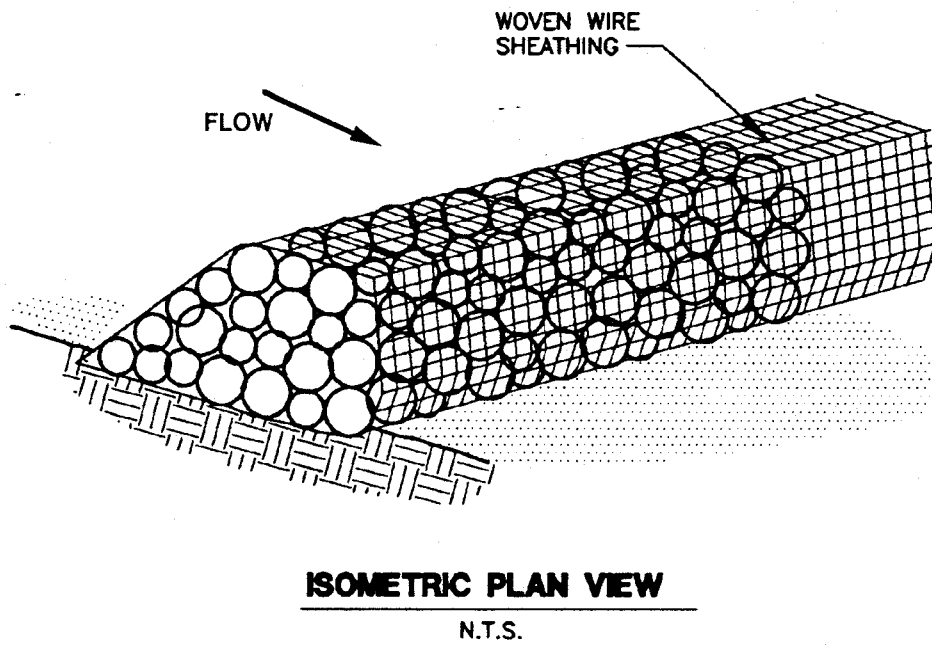
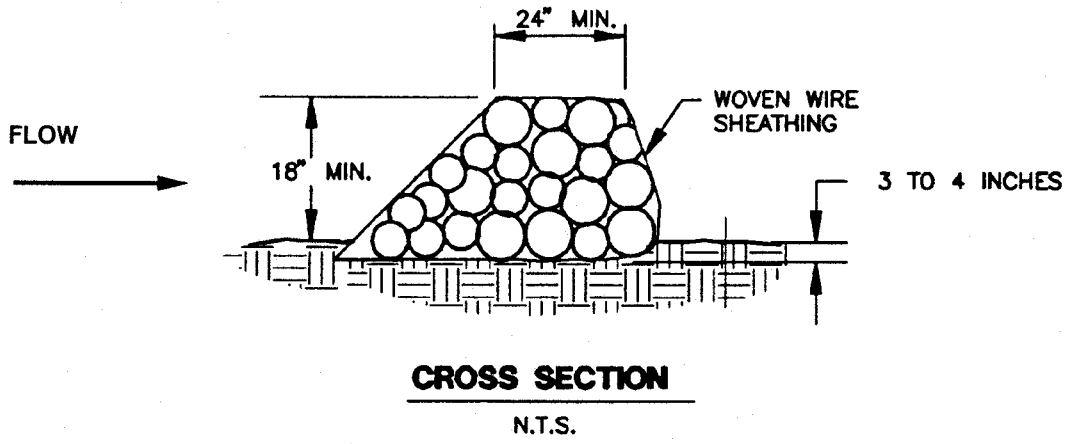

Figure 1-28 Schematic Diagram of a Rock Berm (NCTCOG, 1993)

**Common Trouble Points:**

- (1) Insufficient berm height or length (runoff quickly escapes over the top or around the sides of berm)
- (2) Berm not installed perpendicular to flow line (runoff escaping around one side)

**Inspection and Maintenance Guidelines:**

- (1) Inspection should be made weekly and after each rainfall by the responsible party. For installations in streambeds, additional daily inspections should be made.
- (2) Remove sediment and other debris when buildup reaches 6 inches and dispose of the accumulated silt in an approved manner that will not cause any additional siltation.
- (3) Repair any loose wire sheathing.
- (4) The berm should be reshaped as needed during inspection.
- (5) The berm should be replaced when the structure ceases to function as intended due to silt accumulation among the rocks, washout, construction traffic damage, etc.
- (6) The rock berm should be left in place until all upstream areas are stabilized and accumulated silt removed.

#### 1.4.6 High Service Rock Berms

A high service rock berm should be designed in areas of important environmental significance such as in steep canyons or above permanent springs, pools, recharge features, or other environmentally sensitive areas that may require a higher level of protection. This type of sediment barrier combines the characteristics of a silt fence and a rock berm to provide a substantial level of sediment reduction and a sturdy enough barrier to withstand higher flows. The drainage area to this device should not exceed 5 acres and the slope should be less than 30%.

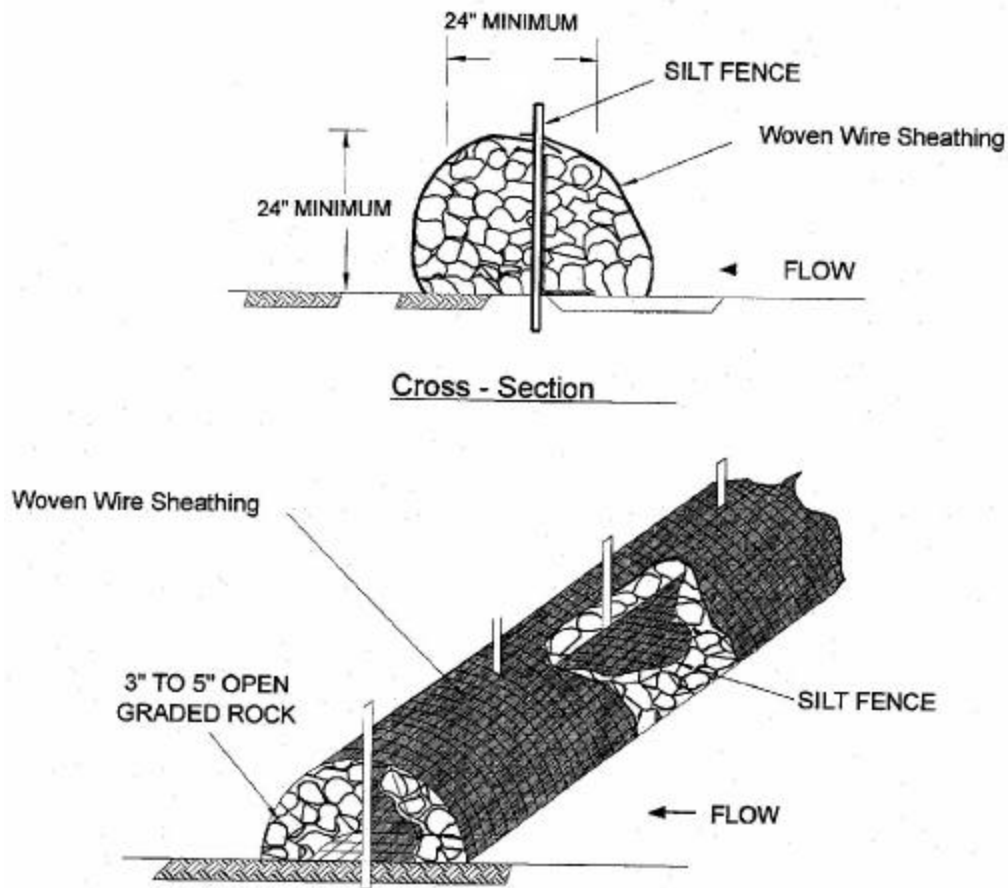

**Figure 1-29 Schematic Diagram of High Service Rock Berm (LCRA, 1998)**

**Materials:**

- (1) Silt fence material should be polypropylene, polyethylene or polyamide woven or nonwoven fabric. The fabric width should be 36 inches, with a minimum unit weight of 4.5 oz/yd, mullen burst strength exceeding 190 lb/in<sup>2</sup>, ultraviolet stability exceeding 70%, and minimum apparent opening size of U.S. Sieve No. 30.
- (2) Fence posts should be made of hot rolled steel, at least 4 feet long with Tee or Y-bar cross section, surface painted or galvanized, minimum nominal weight 1.25 lb/ft<sup>2</sup>, and Brindell hardness exceeding 140. Rebar (either #5 or #6) may also be used to anchor the berm.
- (3) Woven wire backing to support the fabric should be galvanized 2" x 4" welded wire, 12 gauge minimum.
- (4) The berm structure should be secured with a woven wire sheathing having maximum opening of 1 inch and a minimum wire diameter of 20 gauge galvanized and should be secured with shoat rings.
- (5) Clean, open graded 3- to 5-inch diameter rock should be used, except in areas where high velocities or large volumes of flow are expected, where 5- to 8-inch diameter rocks may be used.

**Installation:**

- (1) Lay out the woven wire sheathing perpendicular to the flow line. The sheathing should be 20 gauge woven wire mesh with 1-inch openings.
- (2) Install the silt fence along the center of the proposed berm placement, as with a normal silt fence described in Section 2.4.3.
- (3) Place the rock along the sheathing on both sides of the silt fence as shown in the diagram (Figure 1-29), to a height not less than 24 inches. Clean, open graded 3-5" diameter rock should be used, except in areas where high velocities or large volumes of flow are expected, where 5- to 8-inch diameter rock may be used.
- (4) Wrap the wire sheathing around the rock and secure with tie wire so that the ends of the sheathing overlap at least 2 inches, and the berm retains its shape when walked upon.
- (5) The high service rock berm should be removed when the site is revegetated or otherwise stabilized or it may remain in place as a permanent BMP if drainage is adequate.

**Common Trouble Points:**

- (1) Insufficient berm height or length (runoff quickly escapes over top or around sides of berm).
- (2) Berm not installed perpendicular to flow line (runoff escaping around one side).
- (3) Internal silt fence not anchored securely to ground (high flows displacing berm).
- (4) When installed in streambeds, they often result in diversion scour, so their use in this setting is not recommended.

**Inspection and Maintenance Guidelines:**

- (1) Inspection should be made weekly and after each rainfall by the responsible party. For installations in streambeds, additional daily inspections should be made on rock berm.
- (2) Remove sediment and other debris when buildup reaches 6 inches and dispose of the accumulated silt of in an approved manner.
- (3) Repair any loose wire sheathing.
- (4) The berm should be reshaped as needed during inspection.
- (5) The berm should be replaced when the structure ceases to function as intended due to silt accumulation among the rocks, washout, construction traffic damage, etc.
- (6) The rock berm should be left in place until all upstream areas are stabilized and accumulated silt removed.

#### 1.4.7 Brush Berms

Organic litter and spoil material from site clearing operations is usually burned or hauled away to be dumped elsewhere. Much of this material can be used effectively on the construction site itself. In areas where dense juniper (know locally as “cedar”) thickets must be cleared, construction of brush berms from the cut juniper branches can be an effective alternative to installation of silt fences. The key to constructing an efficient brush berm is in the method used to obtain and place the brush. It will not be acceptable to simply take a bulldozer and push whole trees into a pile. This method does not assure continuous ground contact with the berm and will allow uncontrolled flows under the berm.

Brush berms may be used where there is little or no concentration of water in a channel or other drainage way above the berm. The size of the drainage area should be no greater than one-fourth of an acre per 100 feet of barrier length; the maximum slope length behind the barrier should not exceed 100 feet; and the maximum slope gradient behind the barrier should be less than 50 percent (2:1). Figure 1-30 illustrates a brush berm.

#### **Materials:**

- (1) The brush should consist of woody brush and branches, preferably juniper less than 2 inches in diameter.
- (2) The filter fabric should conform to the specifications for filter fence fabric.
- (3) The rope should be ¼ inch polypropylene or nylon rope.
- (4) The anchors should be 3/8-inch diameter rebar stakes that are 18-inches long.

#### **Guidelines for installation:**

- (1) Lay out the brush berm following the contour as closely as possible.
- (2) The juniper limbs should be cut and hand placed with the vegetated part of the limb in close contact with the ground. Each subsequent branch should overlap the previous branch providing a shingle effect.
- (3) The brush berm should be constructed in lifts with each layer extending the entire length of the berm before the next layer is started.

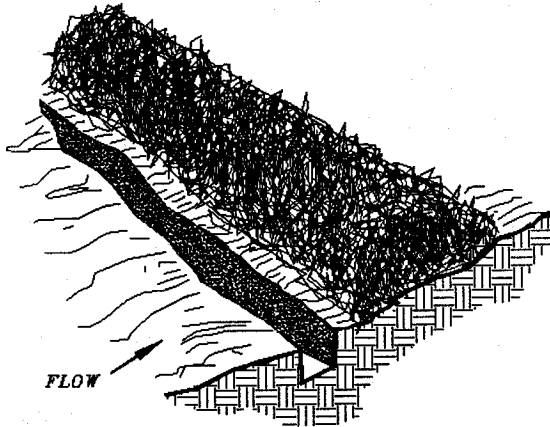

1. EXCAVATE A 4" X 4" TRENCH ALONG THE UPHILL EDGE OF THE BRUSH BARRIER.

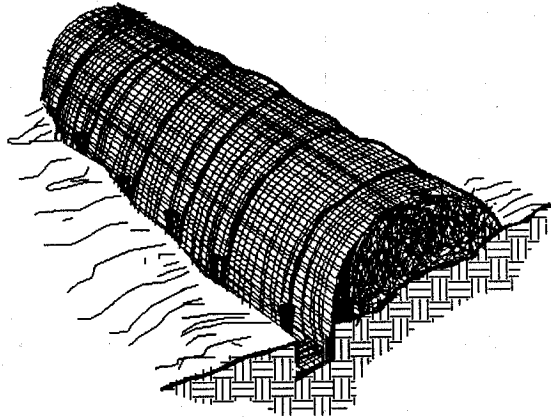

2. DRAPE FILTER FABRIC OVER THE BRUSH BARRIER AND INTO THE TRENCH. FABRIC SHOULD BE SECURED IN THE TRENCH WITH STAKES SET APPROXIMATELY 36" O.C.

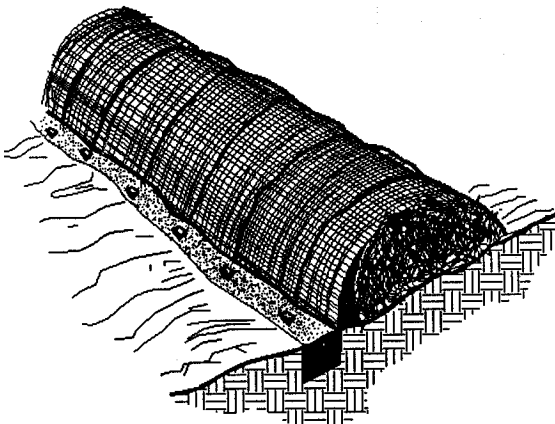

3. BACKFILL AND COMPACT THE EXCAVATED SOIL.

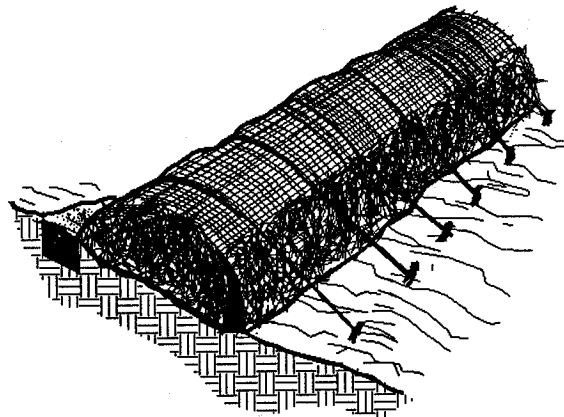

4. SET STAKES ALONG THE DOWN-HILL EDGE OF THE BRUSH BARRIER, AND ANCHOR BY TYING TWINE FROM THE FABRIC TO THE STAKES.

Figure 1-30 Schematic Diagram of a Brush Berm (VA Dept. of Conservation, 1992)

- (4) A trench should be excavated 6-inches wide and 4-inches deep along the length of the barrier and immediately uphill from the barrier.
- (5) The filter fabric should be cut into lengths sufficient to lay across the barrier from its up-slope base to just beyond its peak. The lengths of filter fabric should be draped across the width of the barrier with the uphill edge placed in the trench and the edges of adjacent pieces overlapping each other. Where joints are necessary, the fabric should be spliced together with a minimum 6-inch overlap and securely sealed.
- (6) The trench should be backfilled and the soil compacted over the filter fabric.
- (7) Set stakes into the ground along the downhill edge of the brush barrier, and anchor the fabric by tying rope from the fabric to the stakes. Drive the rope anchors into the ground at approximately a 45-degree angle to the ground on 6-foot centers.
- (8) Fasten the rope to the anchors and tighten berm securely to the ground with a minimum tension of 50 pounds.
- (9) The height of the brush berm should be a minimum of 24 inches after the securing ropes have been tightened.

**Common Trouble Points:**

- (1) Gaps between berm and ground due to uneven ground surface, inadequately compacted berm, or inadequately secured berm (runoff passing directly under berm).
- (2) Berm receiving excessive volumes or velocities of flow (runoff overtopping or displacing berm).



**Inspection and Maintenance Guidelines:**

- (1) The area upstream from the brush berm should be maintained in a condition that will allow accumulated silt to be removed following the runoff of a rainfall event.
- (2) The berm should be inspected weekly or after each rainfall event.
- (3) When the silt reaches a depth of 6 inches it should be removed and disposed of appropriately and in a manner that will not contribute to additional siltation.
- (4) Periodic tightening of the anchoring ropes may be required due to shrinkage of the brush berm as it deteriorates over time;
- (5) Brush berms should be replaced after 3 months or be repaired or reconstructed when loss of foliage occurs or, in the opinion of the TCEQ, they no longer function as intended.

#### 1.4.8 Check Dams

Check dams are small barriers consisting of rock or earthen berms placed across a drainage swale or ditch. They reduce the velocity of small concentrated flows, provide a limited barrier for sediment and help disperse concentrated flows, reducing potential erosion.

They are used primarily in long drainage swales or ditches in which permanent vegetation may not be established and erosive velocities are present. They are typically used in conjunction with other techniques such as inlet protection, riprap or other sediment reduction techniques. Check dams provide limited treatment. They are more useful in reducing flow to acceptable levels for other techniques (NCTCOG, 1993b).

Although check dams are effective in reducing flow velocity and thereby the potential for channel erosion, it is usually better to establish a protective vegetative lining before flow is confined or to install a structural channel lining. However, under circumstances where this is not feasible, check dams are useful.

#### **Materials:**

Although many different types of material can be used to create check dams, aggregate and riprap produce a more stable structure.

- (1) If the drainage area is less than 2 acres, coarse aggregate alone can be used for the dam.
- (2) For drainage areas between 2 and 10 acres, a combination of coarse aggregate and riprap as shown in Figure 1-31 should be used.

#### **Guidelines for installation:**

- (1) The dam height should be between 18 and 36 inches.
- (2) The center of the check dam should be at least 6 inches lower than the outer edges. Field experience has shown that many dams are not constructed to promote this “weir” effect. Stormwater flows are then forced to the stone-soil interface, thereby promoting scour at that point and subsequent failure of the structure to perform its intended function.
- (3) The dam should be designed so that the 2-year, 24-hour storm can pass the dam without causing excessive upstream flooding.

2 ACRES OR LESS OF DRAINAGE AREA:

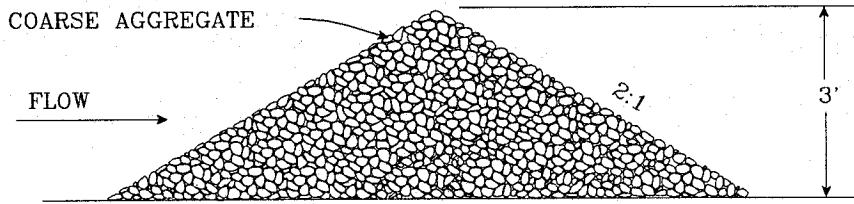
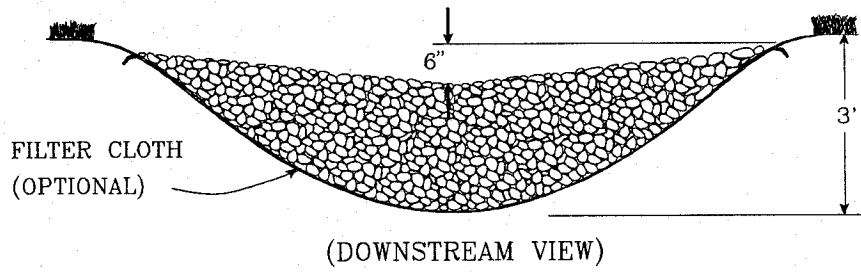

2-10 ACRES OF DRAINAGE AREA:

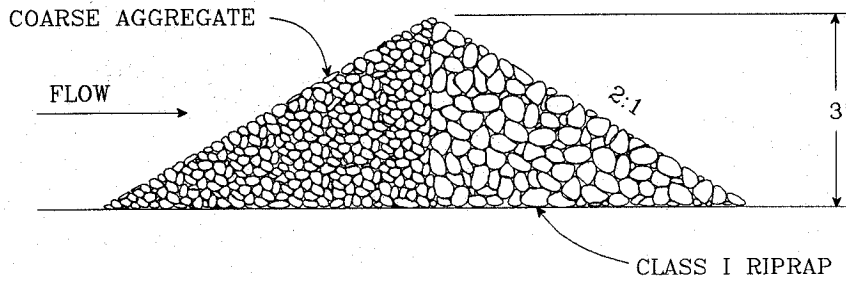
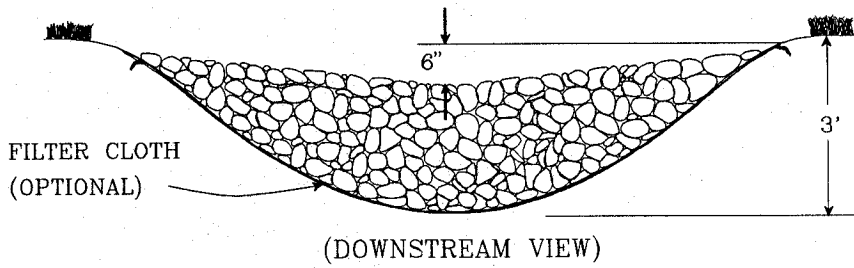

Figure 1-31 Diagram of a Rock Check Dam (VA Dept. of Conservation, 1992)

- (4) For added stability, the base of the check dam can be keyed into the soil approximately 6 inches.
- (5) The maximum spacing between the dams should be such that the toe of the upstream dam is at the same elevation as the top of the downstream dam.
- (6) Stone should be placed according to the configuration in Figure 1-31. Hand or mechanical placement will be necessary to achieve complete coverage of the ditch or swale and to insure that the center of the dam is lower than the edges.
- (7) Filter cloth may be used under the stone to provide a stable foundation and to facilitate the removal of the stone.

**Common Trouble Points:**

- (1) Check dams installed in grass-lined channels may kill the vegetative lining if submergence after rains is too long and/or silting is excessive.
- (2) If check dams are used in grass-lined channels that will be mowed, care should be taken to remove all the stone when the dam is removed. Stones often wash downstream and can damage mowing equipment and present a safety hazard.

**Inspection and Maintenance Guidelines:**

- (1) Check dams should be inspected and checked for sediment accumulation after each runoff-producing storm event.
- (2) Sediment should be removed when it reaches one half of the original height of the measure.
- (3) Regular inspections should be made to insure that the center of the dam is lower than the edges. Erosion caused by high flows around the edges of the dam should be corrected immediately.

#### 1.4.9 Sand Bag Berm

The purpose of a sandbag berm (Figure 1-32) is to intercept sediment-laden water from disturbed areas such as construction in streambeds, create a retention pond, detain sediment and release water in sheet flow. Sand bag berms are used only during construction activities in streambeds when the contributing drainage area is between 5 and 10 acres and the slope is less than 15%, i.e., utility construction in channels, temporary channel crossing for construction equipment, etc.

An additional option for use in streambeds is a rock berm, appropriately sized for the channel. Plastic facing should be installed on the upstream side and the berm anchored to be streambed by drilling into the rock and driving in "T" posts or rebar (#5 or #6) spaced appropriately.

#### **Materials:**

- (1) The sand bag material should be polypropylene, polyethylene, polyamide or cotton burlap woven fabric, minimum unit weight 4 oz/yd<sup>2</sup>, mullen burst strength exceeding 300 psi and ultraviolet stability exceeding 70 percent.
- (2) The bag length should be 24 to 30 inches, width should be 16 to 18 inches and thickness should be 6 to 8 inches.
- (3) Sandbags should be filled with coarse grade sand, free from deleterious material. All sand should pass through a No. 10 sieve. The filled bag should have an approximate weight of 40 pounds.
- (4) Outlet pipe should be schedule 40 or stronger polyvinyl chloride (PVC) having a nominal internal diameter of 4 inches.

#### **Guidelines for installation:**

- (1) The berm should be a minimum height of 18 inches, measured from the top of the existing ground at the upslope toe to the top of the berm.
- (2) The berm should be sized as shown in the plans but should have a minimum width of 48 inches measured at the bottom of the berm and 16 inches measured at the top of the berm.
- (3) Runoff water should flow over the tops of the sandbags or through 4-inch diameter PVC pipes embedded below the top layer of bags as shown in Figure 1-32.

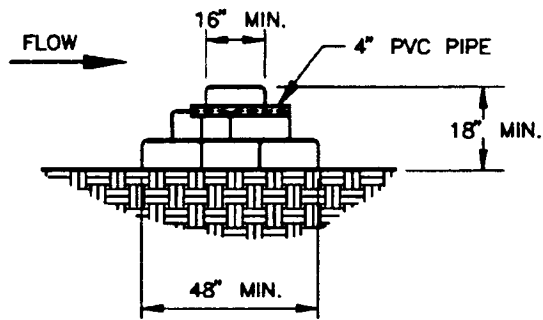

**CROSS SECTION**

N.T.S.

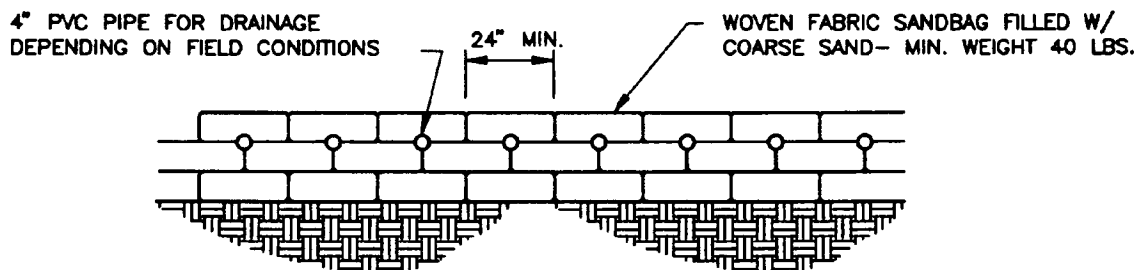

**PROFILE VIEW**

N.T.S.

**Figure 1-32 Schematic of a Sand Bag Berm (NCTCOG, 1993)**

- (4) When a sandbag is filled with material, the open end of the sandbag should be stapled or tied with nylon or poly cord.
- (5) Sandbags should be stacked in at least three rows abutting each other, and in staggered arrangement.
- (6) The base of the berm should have at least 3 sandbags. These can be reduced to 2 and 1 bag in the second and third rows respectively.
- (7) For each additional 6 inches of height, an additional sandbag must be added to each row width.

- (8) A bypass pump-around system, or similar alternative, should be used in conjunction with the berm for effective dewatering of the work area.

**Common Trouble Points:**

- (1) Ponding will occur directly upstream from the berm creating the possibility of flooding, which should be considered prior to its placement.
- (2) Berms are often damaged during periods of high flow, which increases the maintenance requirements.

**Inspection and Maintenance Guidelines:**

- (1) The sand bag berm should be inspected weekly and after each rain.
- (2) The sandbags should be reshaped or replaced as needed during inspection.
- (3) When the silt reaches 6 inches, the accumulated silt should be removed and disposed of at an approved site in a manner that will not contribute to additional siltation.
- (4) The sandbag berm should be left in place until all upstream areas are stabilized and accumulated silt removed; removal should be done by hand.

#### 1.4.10 Vegetative Buffers

Buffer zones are undisturbed strips of natural vegetation or an established suitable planting that will provide a living filter to reduce soil erosion and runoff velocities. Natural buffer zones are used along streams and other bodies of water that need protection from erosion and sedimentation. Vegetative buffers can be used to protect natural swales and be incorporated into natural landscaping of an area. They can provide critical habitat adjacent to streams and wetlands, as well as assisting in controlling erosion, especially on unstable steep slopes.

The buffer zone can be an area of vegetation that is left undisturbed during construction, or it can be newly planted. If buffer zones are preserved, existing vegetation, good planning, and site management are needed to prevent disturbances such as grade changes, excavation, damage from equipment, and other activities. The creation of new buffer strips requires the establishment of a good dense turf (at least 80% coverage), trees, and shrubs.

#### **Guidelines for installation:**

- (1) Preserving natural vegetation or plantings in clumps, blocks, or strips is generally the easiest and most successful method.
- (2) All unstable steep slopes should be left in natural vegetation.
- (3) Fence or flag clearing limits and keep all equipment and construction debris out of the natural areas.
- (4) Keep all excavations outside the dripline of trees and shrubs.
- (5) Debris or extra soil should not be pushed into the buffer zone area because it will cause damage from burying and smothering.
- (6) The minimum width of a vegetative buffer used for sediment control should be 50 feet.

#### **Inspection and Maintenance Guidelines:**

Inspection and careful maintenance are important to ensure healthy vegetation. The need for routine maintenance such as mowing, fertilizing, irrigating, and weed and pest control will depend on the species of plants and trees, soil types, location and climatic conditions. County agricultural extension agencies are a good source of this type of information.



#### 1.4.11 Inlet Protection

Storm sewers that are made operational prior to stabilization of the associated drainage areas can convey large amounts of sediment to natural drainage ways. In case of extreme sediment loading, the storm sewer itself may clog and lose a major portion of its capacity. To avoid these problems, it is necessary to prevent sediment from entering the system at the inlets. The following guidelines for inlet protection are based primarily on recommendations by the Virginia Dept. of Conservation and Recreation (1992) and the North Central Texas Council of Governments (NCTCOG, 1993b).

In developments for which drainage is to be conveyed by underground storm sewers (i.e., streets with curbs and gutters), all inlets that may receive storm runoff from disturbed areas should be protected. Temporary inlet protection is a series of different measures that provide protection against silt transport or accumulation in storm sewer systems. This clogging can greatly reduce or completely stop the flow in the pipes. The different measures are used for different site conditions and inlet types.

Care should be taken when choosing a specific type of inlet protection. Field experience has shown that inlet protection that causes excessive ponding in an area of high construction activity may become so inconvenient that it is removed or bypassed, thus transmitting sediment-laden flows unchecked. In such situations, a structure with an adequate overflow mechanism should be utilized.

It should also be noted that inlet protection devices are designed to be installed on construction sites and not on streets and roads open to the public. When used on public streets these devices will cause ponding of runoff, which can cause minor flooding and can present a traffic hazard. An example of appropriate siting would be a new subdivision where the storm drain system is installed before the area is stabilized and the streets open to the general public. When construction occurs adjacent to active streets, the sediment should be controlled on site and not on public thoroughfares. Occasionally, roadwork or utility installation will occur on public roads. In these cases, inlet protection is an appropriate temporary BMP.

The following inlet protection devices are for drainage areas of one acre or less. Runoff from larger disturbed areas should be routed to a temporary sediment trap or basin.

Filter barrier protection using silt fence is appropriate when the drainage area is less than one acre and the basin slope is less than five percent. This type of protection is not applicable in paved areas.

Block and gravel protection is used when flows exceed 0.5 cubic feet per second and it is necessary to allow for overtopping to prevent flooding. This form of protection is also useful for curb type inlets as it works well in paved areas.

Wire mesh and gravel protection is used when flows exceed 0.5 cubic feet per second and construction traffic may occur over the inlet. This form of protection may be used with both curb and drop inlets.

Excavated impoundment protection around a drop inlet may be used for protection against sediment entering a storm drain inlet. With this method, it is necessary to install weep holes to allow the impoundment to drain completely. If this measure is implemented, the impoundment should be sized such that the volume of excavation is 3,600 cubic feet per acre (equivalent to 1 inch of runoff) of disturbed area entering the inlet.

**Materials:**

- (1) Filter fabric should be a nylon reinforced polypropylene fabric which meets the following minimum criteria: Tensile Strength, 90 lbs.; Puncture Rating, 60 lbs.; Mullen Burst Rating, 280 psi; Apparent Opening Size, U.S. Sieve No. 70.
- (2) Posts for fabric should be 2" x 4" pressure treated wood stakes or galvanized steel, tubular in cross-section or they may be standard fence "T" posts.
- (3) Concrete blocks should be standard 8" x 8" x 16" concrete masonry units.
- (4) Wire mesh should be standard hardware cloth or comparable wire mesh with an opening size not to exceed 1/2 inch.

**Guidelines for installation:**

*Silt Fence Drop Inlet Protection*

- (1) Silt fence should conform to the specifications listed above and should be cut from a continuous roll to avoid joints.
- (2) For stakes, use 2 x 4-inch wood or equivalent metal with a minimum length of 3 feet.
- (3) Space stakes evenly around the perimeter of the inlet a maximum of 3 feet apart, and securely drive them into the ground, approximately 18 inches deep (Figure 1-33).
- (4) To provide needed stability to the installation, a frame with 2 x 4-inch wood strips around the crest of the overflow area at a maximum of 1½ feet above the drop inlet crest should be provided.

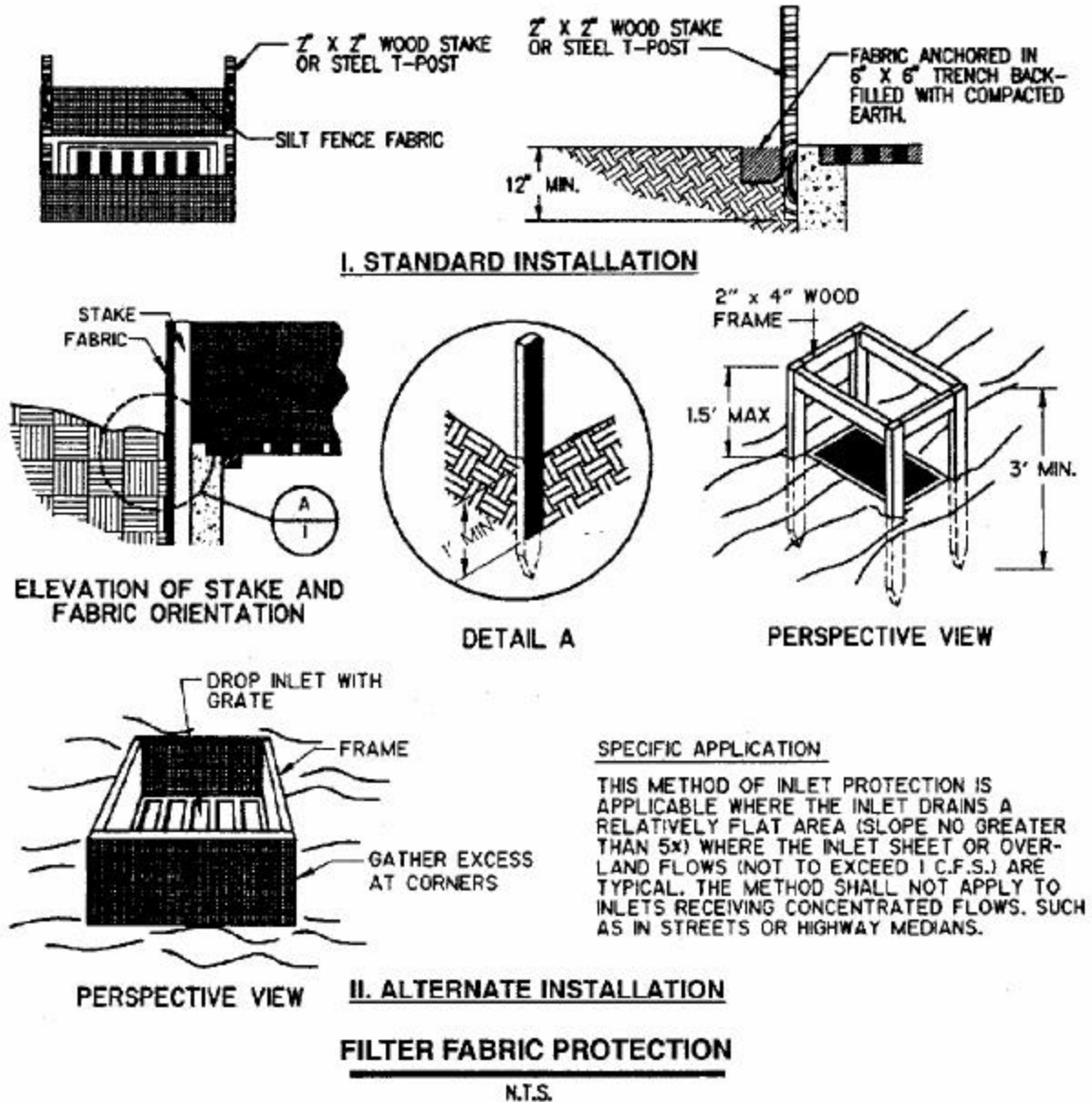

**Figure 1-33 Filter Fabric Inlet Protection (NCTCOG, 1993)**

- (5) Place the bottom 12 inches of the fabric in a trench and backfill the trench with 12 inches of compacted soil.
- (6) Fasten fabric securely by staples or wire to the stakes and frame. Joints must be overlapped to the next stake.
- (7) It may be necessary to build a temporary dike on the down slope side of the structure to prevent bypass flow.

If the drop inlet is above the finished grade, the grate may be completely covered with filter fabric. The fabric should be securely attached to the entire perimeter of the inlet using 1"x 2" wood strips and appropriate fasteners.

### *Gravel and Wire Mesh Drop Inlet Sediment Filter*

- (1) Wire mesh should be laid over the drop inlet so that the wire extends a minimum of 1 foot beyond each side of the inlet structure. Wire mesh with 1/2-inch openings should be used. If more than one strip of mesh is necessary, the strips should be overlapped (see Figure 1-34).

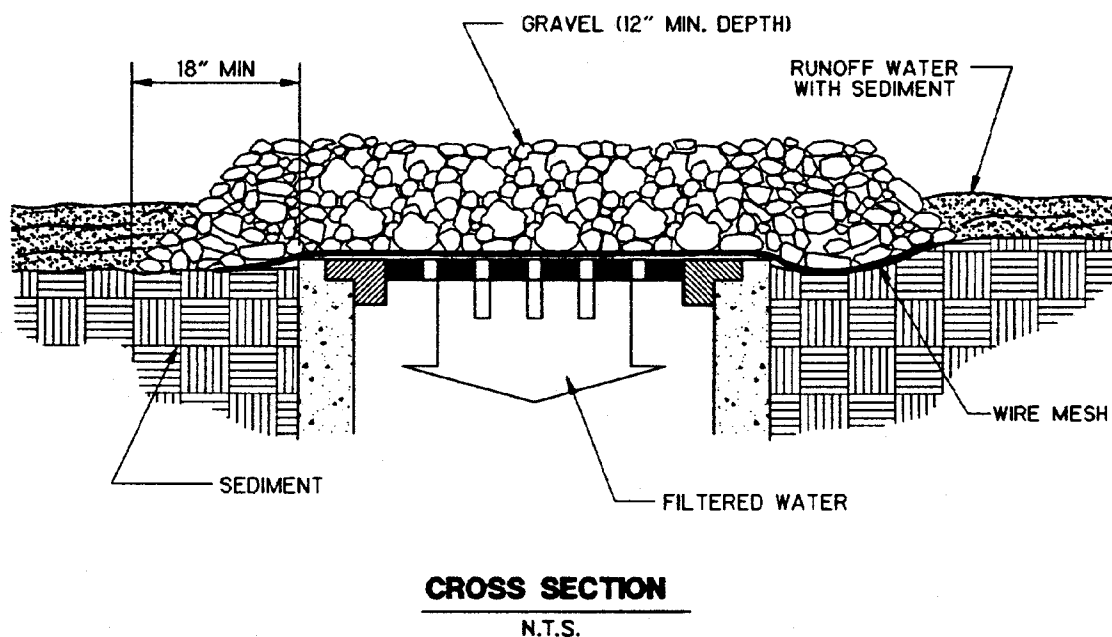

**Figure 1-34 Wire Mesh and Gravel Inlet Protection (NCTCOG, 1993)**

- (2) Coarse aggregate should be placed over the wire mesh as indicated in Figure 1-34. The depth of stone should be at least 12 inches over the entire inlet opening. The stone should extend beyond the inlet opening at least 18 inches on all sides.
- (3) If the stone filter becomes clogged with sediment so that it no longer adequately performs its function, the stones must be pulled away from the inlet, cleaned and/or replaced.

Note: This filtering device has no overflow mechanism; therefore, ponding is likely especially if sediment is not removed regularly. This type of device should never be used where overflow may endanger an exposed fill slope. Consideration should also be given to the possible effects of ponding on traffic movement, nearby structures, working areas, adjacent property, etc.

### *Block and Gravel Drop Inlet Sediment Filter*

- (1) Place concrete blocks lengthwise on their sides in a single row around the perimeter of the inlet, with the ends of adjacent blocks abutting. The height of the barrier can be varied, depending on design needs, by stacking combinations of 4-inch, 8-inch and 12-inch wide blocks. The barrier of blocks should be between 12 and 24 inches high.
- (2) Wire mesh should be placed over the outside vertical face (webbing) of the concrete blocks to prevent stone from being washed through the holes in the blocks. Wire mesh with 1/2-inch openings should be used.
- (3) Stone should be piled against the wire to the top of the block barrier, as shown in Figure 1-35.
- (4) If the stone filter becomes clogged with sediment so that it no longer adequately performs its function, the stone must be pulled away from the blocks, cleaned and replaced.

### *Block and Gravel Curb Inlet Sediment Filter*

- (1) Two concrete blocks should be placed on their sides abutting the curb at either side of the inlet opening.
- (2) A 2-inch x 4-inch stud should be cut and placed through the outer holes of each spacer block to help keep the front blocks in place.
- (3) Concrete blocks should be placed on their sides across the front of the inlet and abutting the spacer blocks as depicted in Figure 1-35.
- (4) Wire mesh should be placed over the outside vertical face (webbing) of the concrete blocks to prevent stone from being washed through the holes in the blocks. Wire mesh with 1/2-inch openings should be used.
- (5) Coarse aggregate should be piled against the wire to the top of the barrier as shown in Figure 1-35.
- (6) If the stone filter becomes clogged with sediment so that it no longer adequately performs its function, the stone must be pulled away from the blocks, cleaned and/or replaced.

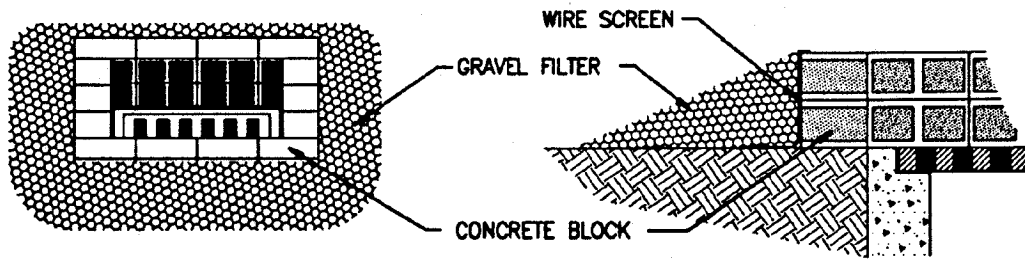

**DROP INLET PROTECTION**

N.T.S.

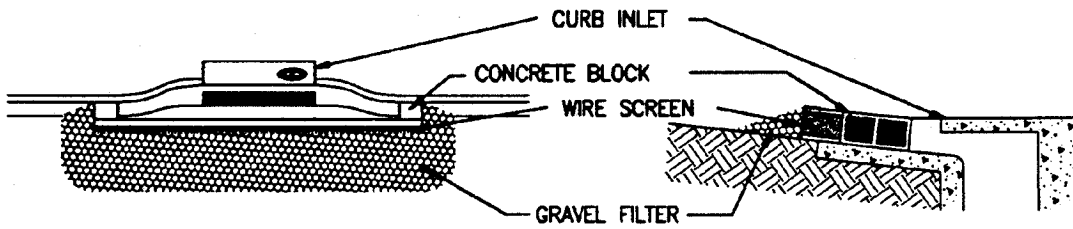

**CURB INLET PROTECTION**

N.T.S.

Figure 1-35 Block and Gravel Inlet Protection (NCTCOG, 1993)

*Excavated Drop Inlet Sediment Trap*

- (1) The excavated trap should be sized to provide a minimum storage capacity calculated at 3,600 cubic feet per acre of drainage area. A trap should be no less than 1-foot nor more than 2 feet deep measured from the top of the inlet structure. Side slopes should not be steeper than 2:1 (see Figure 1-36).

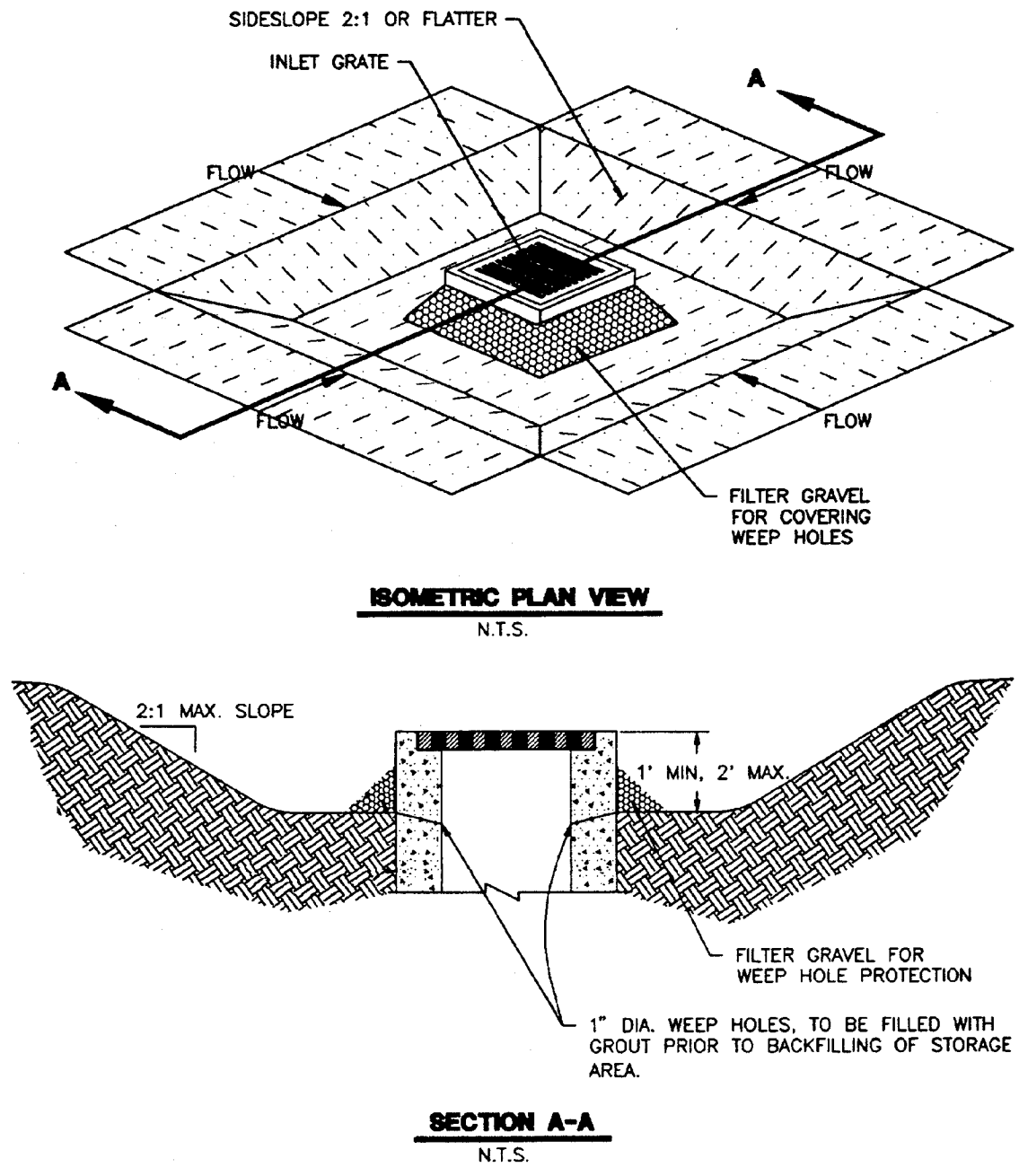

**Figure 1-36 Excavated Inlet Protection (NCTCOG, 1993)**

- (2) The slope of the basin may vary to fit the drainage area and terrain. Observations must be made to check trap efficiency and modifications should be made as necessary to ensure satisfactory trapping of sediment. Where an inlet is located so as to receive concentrated flows, such as in a highway median, it is recommended that the basin have a rectangular shape in a 2:1 (length/width) ratio, with the length oriented in the direction of the flow.

- (3) Sediment should be removed and the trap restored to its original dimensions when the sediment has accumulated to one-half the design depth of the trap. Removed sediment should be deposited in a suitable area and in a manner such that it will not erode.

*Curb Inlet Protection with 2-inch x 4-inch Wooden Weir*

- (1) Attach a continuous piece of wire mesh (30-inch minimum width x inlet throat length plus 4 feet) to the 2-inch x 4-inch wooden weir (with a total length of throat length plus 2 feet) as shown in Figure 1-37. Wood should be “construction grade” lumber.
- (2) Place a piece of approved filter cloth of the same dimensions as the wire mesh over the wire mesh and securely attach to the 2-inch x 4-inch weir.
- (3) Securely nail the 2-inch x 4-inch weir to the 9-inch long vertical spacers which are to be located between the weir and inlet face at a maximum 6-foot spacing.
- (4) Place the assembly against the inlet throat and nail 2-foot (minimum) lengths of 2-inch x 4-inch board to the top of the weir at spacer locations. These 2-inch x 4-inch anchors should extend across the inlet tops and be held in place by sandbags or alternate weight.
- (5) The assembly should be placed so that the end spacers are a minimum 1 foot beyond both ends of the throat opening.
- (6) Form the wire mesh and filter cloth to the concrete gutter and against the face of curb on both sides of the inlet. Place coarse aggregate over the wire mesh and filter fabric in such a manner as to prevent water from entering the inlet under or around the filter cloth.
- (7) This type of protection should be inspected frequently and the filter cloth and stone replaced when clogged with sediment.
- (8) Assure that storm flow does not bypass inlet by installing temporary earth or asphalt dikes directing flow into inlet.



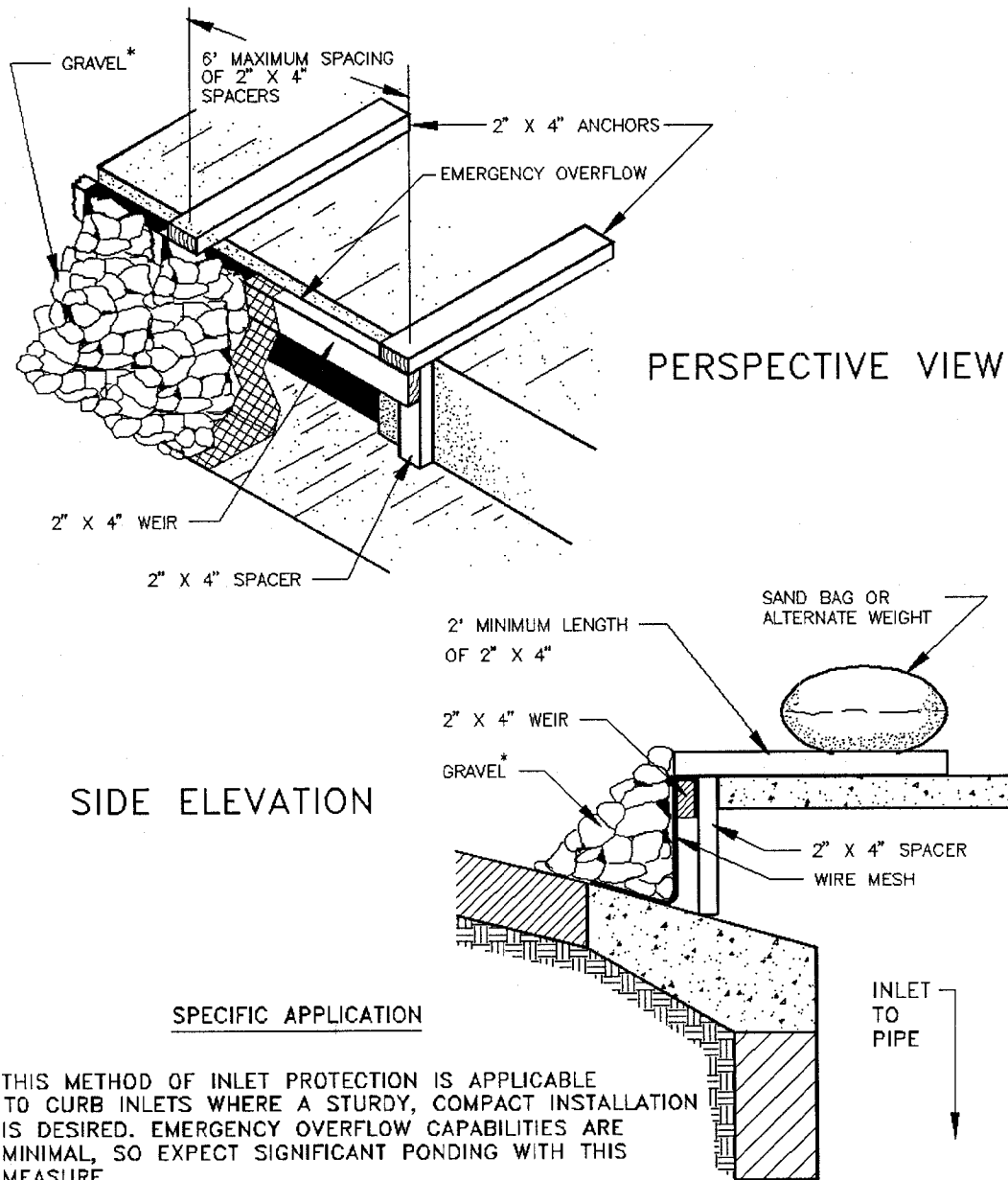

**Figure 1-37 Wooden Weir Curb Inlet Protection (VA Dept of Conservation, 1992)**

**Common Trouble Points:**

- (1) Gaps between the inlet protection and the curb (flows bypass around side of filter).
- (2) Filter fabric skirt not anchored to pavement (flows pass under filter).

### *Bagged Gravel Inlet Filter*

Sandbags filled with pea gravel can also be used to construct a sediment barrier around curb and drain inlets. The sandbags should be filled with washed pea gravel and stacked to form a continuous barrier about 1 foot high around the inlets. The bags should be tightly abutted against each other to prevent runoff from flowing between the bags. This measure should be installed as shown in Figure 1-38.

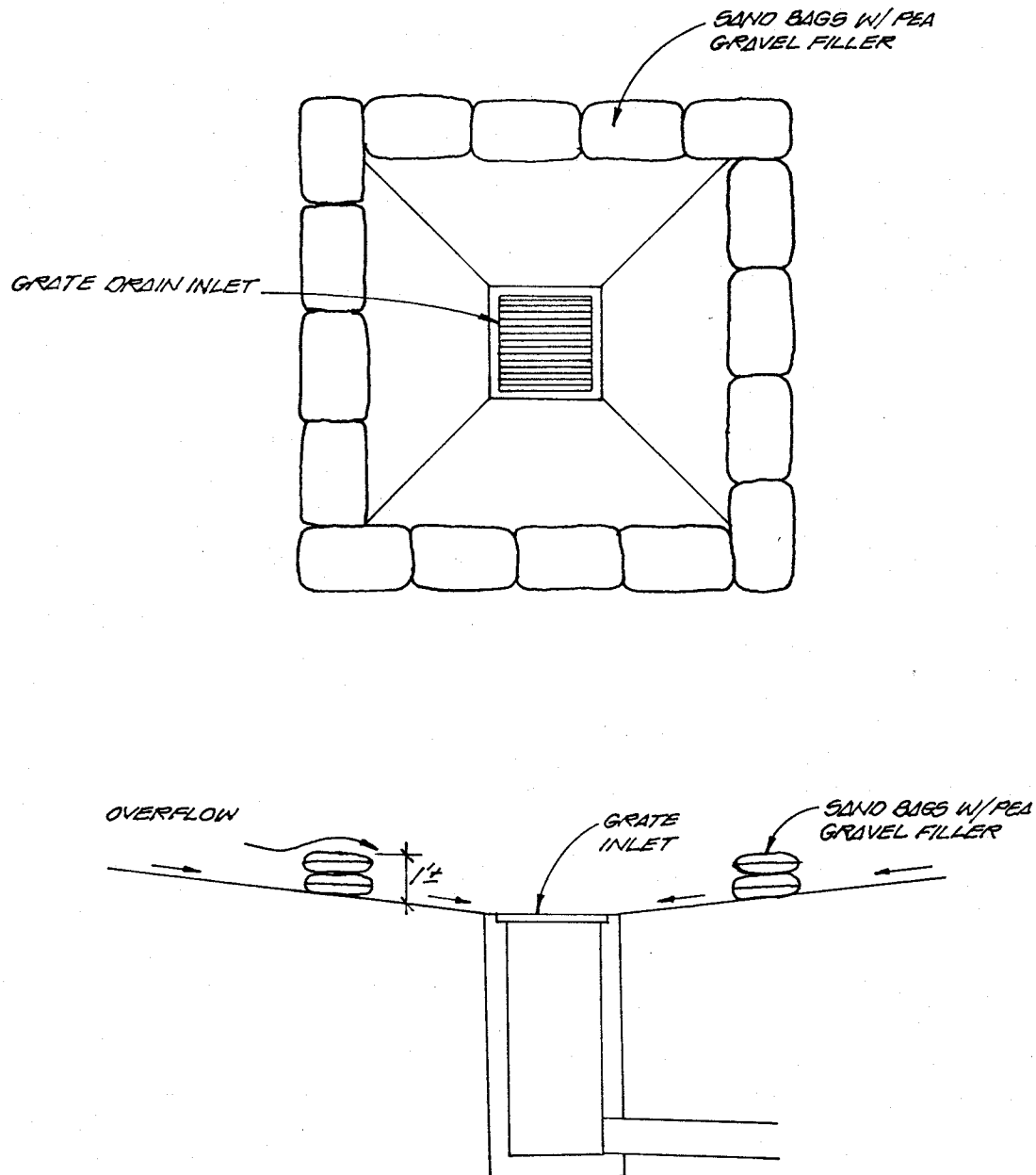

**Figure 1-38 Diagram of Bagged Gravel Grate Inlet Protection (Pape-Dawson)**

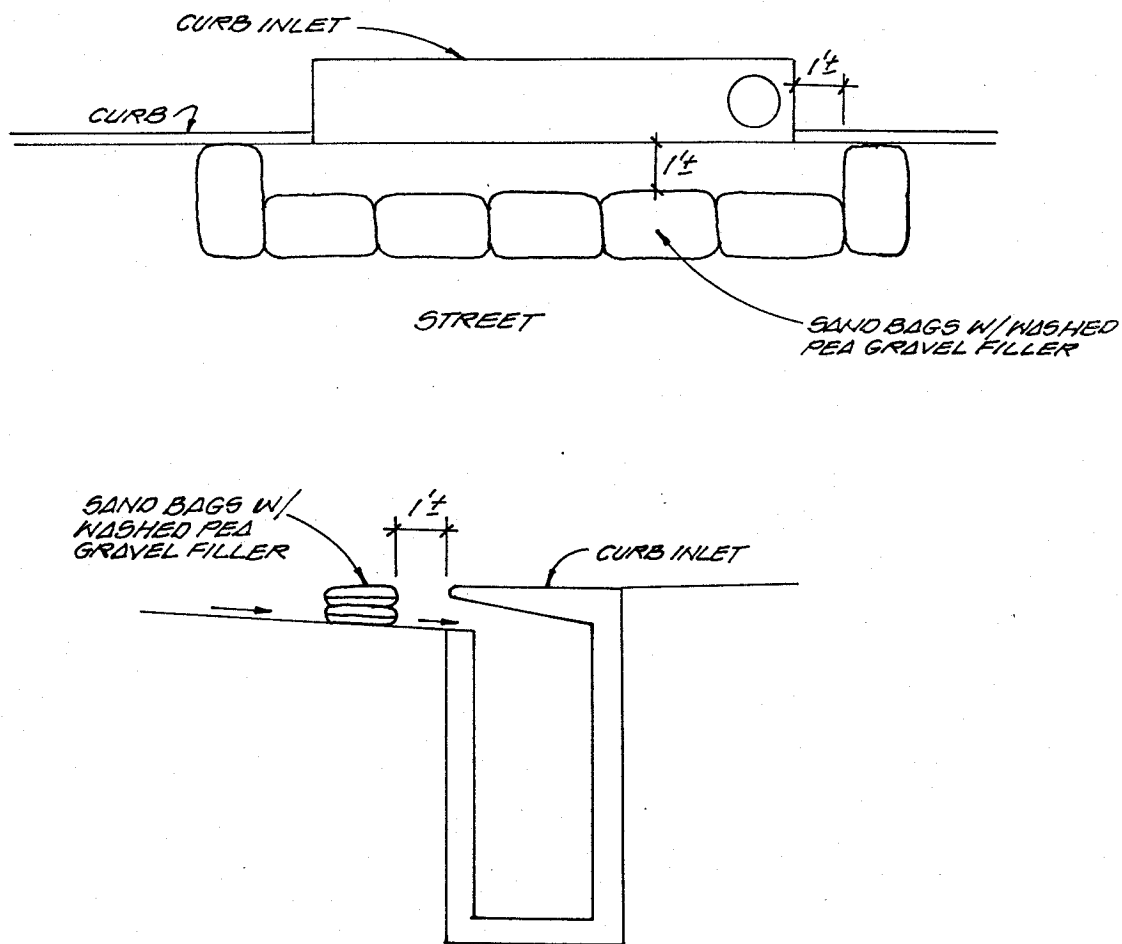

**Figure 1-39 Diagram of Bagged Gravel Curb Inlet Protection (Pape-Dawson).**

**Inspection and Maintenance Guidelines:**

- (1) Inspection should be made weekly and after each rainfall. Repair or replacement should be made promptly as needed by the contractor.
- (2) Remove sediment when buildup reaches a depth of 3 inches. Removed sediment should be deposited in a suitable area and in such a manner that it will not erode.
- (3) Check placement of device to prevent gaps between device and curb.
- (4) Inspect filter fabric and patch or replace if torn or missing.

- (5) Structures should be removed and the area stabilized only after the remaining drainage area has been properly stabilized.

#### 1.4.12 Stone Outlet Sediment Trap

A stone outlet sediment trap is an impoundment created by the placement of an earthen and stone embankment to prevent soil and sediment loss from a site. The purpose of a sediment trap is to intercept sediment-laden runoff and trap the sediment in order to protect drainage ways, properties and rights of way below the sediment trap from sedimentation. A sediment trap is usually installed at points of discharge from disturbed areas. The drainage area for a sediment trap is recommended to be less than 5 acres. Larger areas should be treated using a sediment basin. A sediment trap differs from a sediment basin mainly in the type of discharge structure. A schematic of a sediment trap is shown in Figure 1-40.

The trap should be located to obtain the maximum storage benefit from the terrain, for ease of cleanout and disposal of the trapped sediment and to minimize interference with construction activities. The volume of the trap should be at least 3600 cubic feet per acre of drainage area.

#### **Materials:**

- (1) All aggregate should be at least 3 inches in diameter and should not exceed a volume of 0.5 cubic foot.
- (2) The geotextile fabric specification should be woven polypropylene, polyethylene or polyamide geotextile, minimum unit weight of 4.5 oz/yd<sup>2</sup>, mullen burst strength at least 250 lb/in<sup>2</sup>, ultraviolet stability exceeding 70%, and equivalent opening size exceeding 40.

#### **Installation:**

- (1) Earth Embankment: Place fill material in layers not more than 8 inches in loose depth. Before compaction, moisten or aerate each layer as necessary to provide the optimum moisture content of the material. Compact each layer to 95 percent standard proctor density. Do not place material on surfaces that are muddy or frozen. Side slopes for the embankment are to be 3:1. The minimum width of the embankment should be 3 feet.
- (2) A gap is to be left in the embankment in the location where the natural confluence of runoff crosses the embankment line. The gap is to have a width in feet equal to 6 times the drainage area in acres.
- (3) Geotextile Covered Rock Core: A core of filter stone having a minimum height of 1.5 feet and a minimum width at the base of 3 feet should be placed across the opening of the earth embankment and should be covered by geotextile fabric

which should extend a minimum distance of 2 feet in either direction from the base of the filter stone core.

- (4) Filter Stone Embankment: Filter stone should be placed over the geotextile and is to have a side slope which matches that of the earth embankment of 3:1 and should cover the geotextile/rock core a minimum of 6 inches when installation is complete. The crest of the outlet should be at least 1 foot below the top of the embankment.

#### **Common Trouble Points:**

- (1) Can cause minor flooding upstream of dam, impacting construction operations.
- (2) The cost of construction, availability of materials, and the amount of land required limit the application of this measure.

#### **Inspection and Maintenance Guidelines:**

- (1) Inspection should be made weekly and after each rainfall. Check the embankment, spillways, and outlet for erosion damage, and inspect the embankment for piping and settlement. Repair should be made promptly as needed by the contractor.
- (2) Trash and other debris should be removed after each rainfall to prevent clogging of the outlet structure.
- (3) Sediment should be removed and the trap restored to its original dimensions when the sediment has accumulated to half of the design depth of the trap.
- (4) Sediment removed from the trap should be deposited in an approved spoils area and in such a manner that it will not cause additional siltation.

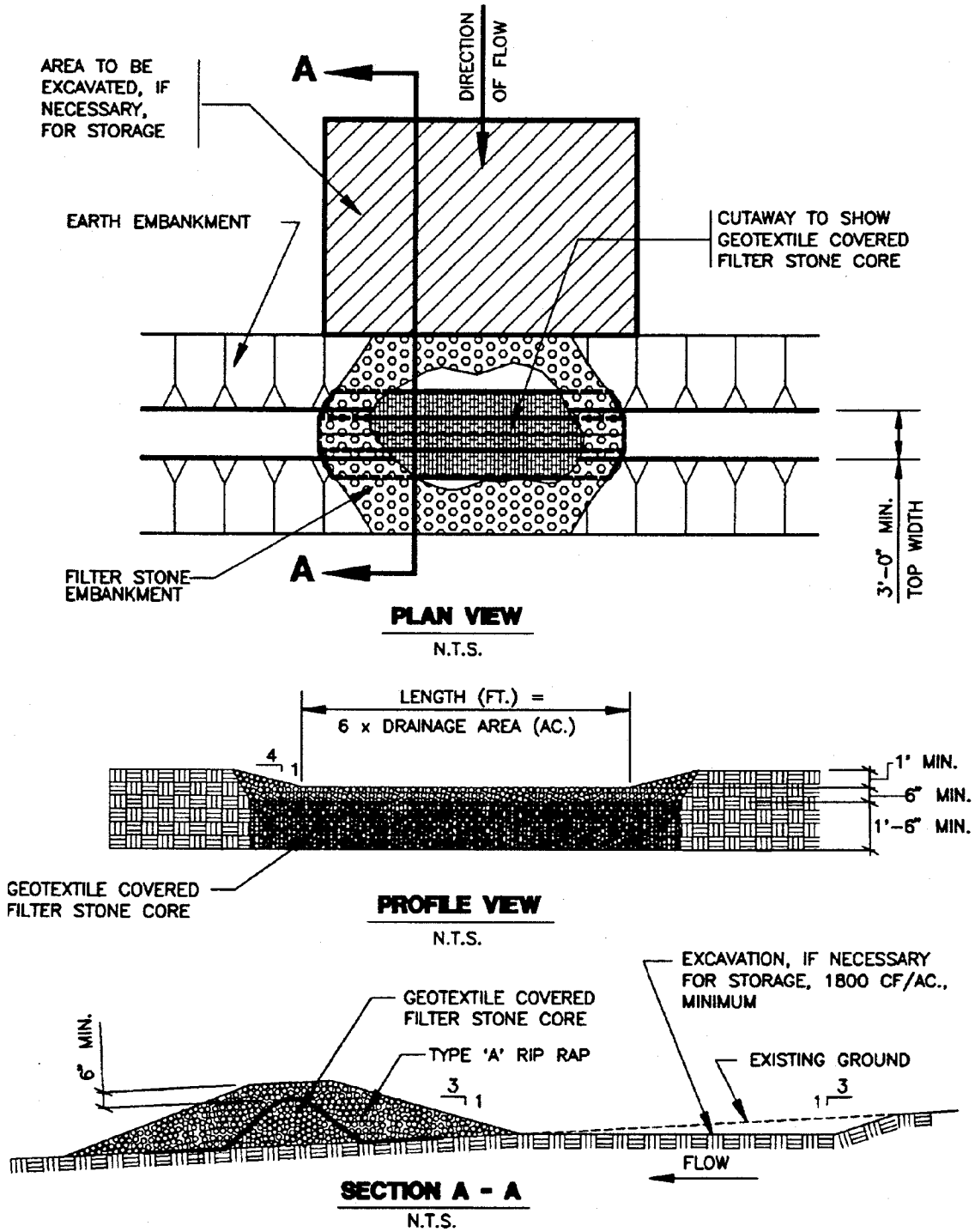

Figure 1-40 Schematic Diagram of a Sediment Trap (NCTCOG, 1993)

### 1.4.13 Sediment Basins

The purpose of a sediment basin is to intercept sediment-laden runoff and trap the sediment in order to protect drainage ways, properties and rights of way below the sediment basin from sedimentation. A sediment basin is usually installed at points of discharge from disturbed areas. The drainage area for a sediment basin is recommended to be less than 100 acres.

Sediment basins are effective for capturing and slowly releasing the runoff from larger disturbed areas thereby allowing sedimentation to take place. A sediment basin can be created where a permanent pond BMP is being constructed. Guidelines for construction of the permanent BMP should be followed, but revegetation, placement of underdrain piping, and installation of sand or other filter media should not be carried out until the site construction phase is complete. A schematic of a sediment basin is shown in Figure 1-41.

#### **Materials:**

- (1) Riser should be corrugated metal or reinforced concrete pipe or box and should have watertight fittings or end to end connections of sections.
- (2) An outlet pipe of corrugated metal or reinforced concrete should be attached to the riser and should have positive flow to a stabilized outlet on the downstream side of the embankment.
- (3) An anti-vortex device and rubbish screen should be attached to the top of the riser and should be made of polyvinyl chloride or corrugated metal.

#### **Basin Design and Construction:**

- (1) For common drainage locations that serve an area with ten or more acres disturbed at one time, a sediment basin should provide storage for a volume of runoff from a two-year, 24-hour storm from each disturbed acre drained. The rainfall depths for the design storm are shown for each county in Table 1-6.



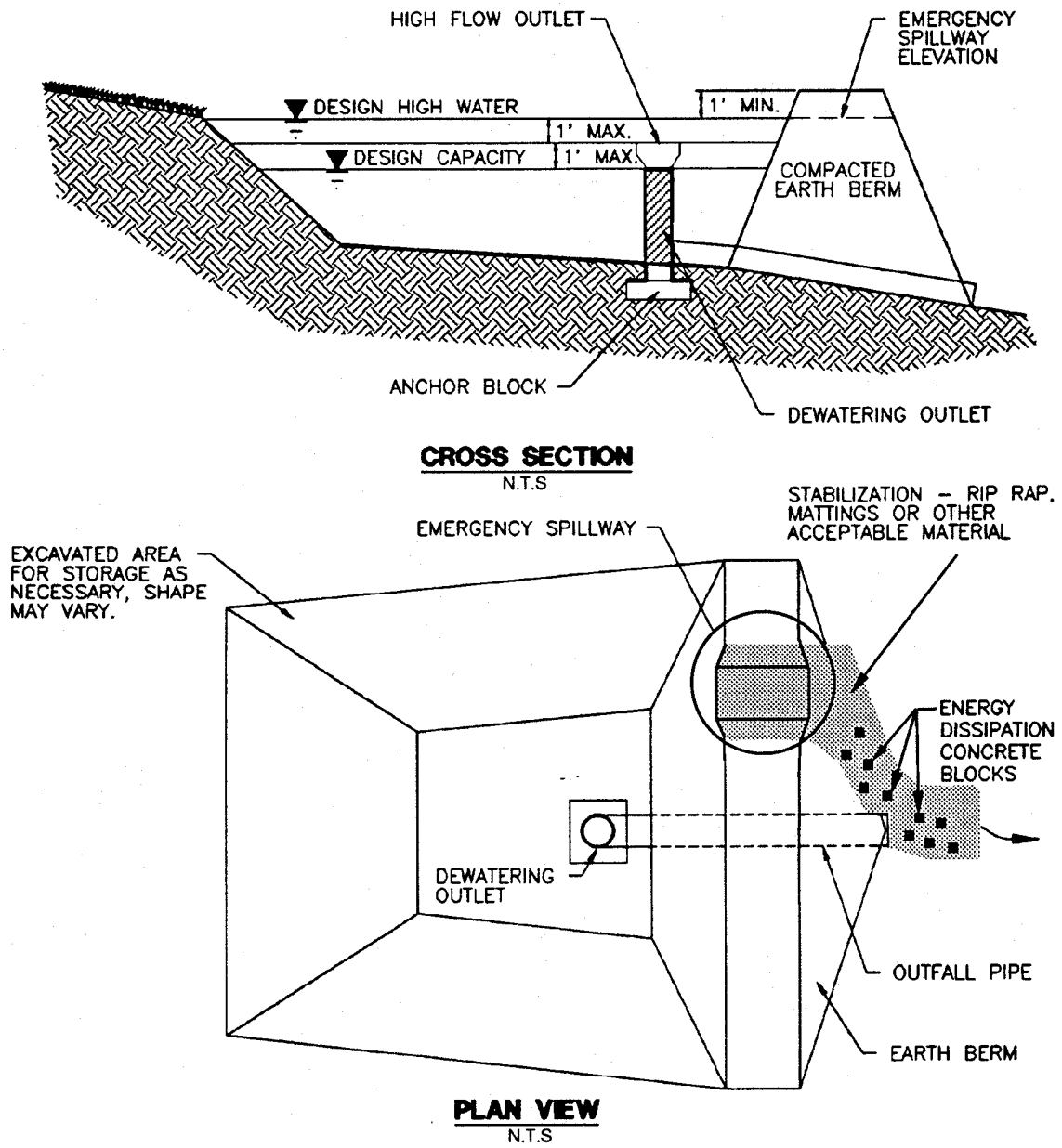

Figure 1-41 Schematic of a Sediment Basin (NCTCOG, 1993)

**Table 1-6 Design Storm Depth by County (Asquith and Roussel, 2004)**

| <b>County</b> | <b>2-year, 24-hour Storm Depth (in)</b> |
|---------------|---|
| Bexar         | 3.8                                     |
| Comal         | 3.7                                     |
| Hays          | 3.5                                     |
| Kinney        | 3.2                                     |
| Medina        | 3.4                                     |
| Travis        | 3.4                                     |
| Uvalde        | 3.3                                     |
| Williamson    | 3.4                                     |

- (2) The basin length to width ratio should be at least 2:1 to improve trapping efficiency. The shape may be attained by excavation or the use of baffles. The lengths should be measured at the elevation of the riser de-watering hole.
- (3) Place fill material in layers not more than 8 inches in loose depth. Before compaction, moisten or aerate each layer as necessary to provide the optimum moisture content of the material. Compact each layer to 95 percent standard proctor density. Do not place material on surfaces that are muddy or frozen. Side slopes for the embankment should be 3:1 (H:V).
- (4) An emergency spillway should be installed adjacent to the embankment on undisturbed soil and should be sized to carry the full amount of flow generated by a 10-year, 3-hour storm with 1 foot of freeboard less the amount which can be carried by the principal outlet control device.
- (5) The emergency spillway should be lined with riprap as should the swale leading from the spillway to the normal watercourse at the base of the embankment.
- (6) The principal outlet control device should consist of a rigid vertically oriented pipe or box of corrugated metal or reinforced concrete. Attached to this structure should be a horizontal pipe, which should extend through the embankment to the toe of fill to provide a de-watering outlet for the basin.
- (7) An anti-vortex device should be attached to the inlet portion of the principal outlet control device to serve as a rubbish screen.
- (8) A concrete base should be used to anchor the principal outlet control device and should be sized to provide a safety factor of 1.5 (downward forces = 1.5 buoyant forces).
- (9) The basin should include a permanent stake to indicate the sediment level in the pool and marked to indicate when the sediment occupies 50% of the basin volume (not the top of the stake).

- (10) The top of the riser pipe should remain open and be guarded with a trash rack and anti-vortex device. The top of the riser should be 12 inches below the elevation of the emergency spillway. The riser should be sized to convey the runoff from the 2-year, 3-hour storm when the water surface is at the emergency spillway elevation. For basins with no spillway the riser must be sized to convey the runoff from the 10-yr, 3-hour storm.
- (11) Anti-seep collars should be included when soil conditions or length of service make piping through the backfill a possibility.
- (12) The 48-hour drawdown time will be achieved by using a riser pipe perforated at the point measured from the bottom of the riser pipe equal to ½ the volume of the basin. This is the maximum sediment storage elevation. The size of the perforation may be calculated as follows:

$$A_o = \frac{A_s \times \sqrt{2h}}{C_d \times 980,000}$$

Where:

$A_o$  = Area of the de-watering hole, ft<sup>2</sup>

$A_s$  = Surface area of the basin, ft<sup>2</sup>

$C_d$  = Coefficient of contraction, approximately 0.6

$h$  = head of water above the hole, ft

Perforating the riser with multiple holes with a combined surface area equal to  $A_o$  is acceptable.

### **Common Trouble Points:**

- (1) Storm events that exceed the design storm event can cause damage to the spillway structure of the basin and may cause adverse impacts downstream.
- (2) Piping (flow occurring in the fill material) around outlet pipe can cause failure of the embankment.

**Inspection and Maintenance Guidelines:**

- (1) Inspection should be made weekly and after each rainfall. Check the embankment, spillways, and outlet for erosion damage, and inspect the embankment for piping and settlement. Repair should be made promptly as needed by the contractor.
- (2) Trash and other debris should be removed after each rainfall to prevent clogging of the outlet structure.
- (3) Accumulated silt should be removed and the basin should be re-graded to its original dimensions at such point that the capacity of the impoundment has been reduced to 75% of its original storage capacity.
- (4) The removed sediment should be stockpiled or redistributed in areas that are protected from erosion.

#### 1.4.14 Fiber Rolls

A fiber roll consists of straw, coconut fibers, or other similar materials bound into a tight tubular roll. When fiber rolls are placed at the toe and on the face of slopes, they intercept runoff, reduce its flow velocity, release the runoff as sheet flow, and provide removal of sediment from the runoff. By interrupting the length of a slope, fiber rolls can also reduce erosion.

Fiber rolls may be suitable:

- Along the toe, top, face, and at grade breaks of exposed and erodible slopes to shorten slope length and spread runoff as sheet flow
- At the end of a downward slope where it transitions to a steeper slope
- Along the perimeter of a project
- As check dams in unlined ditches
- Down-slope of exposed soil areas
- Around temporary stockpiles

Limitations:

- Fiber rolls are not effective unless trenched
- Fiber rolls at the toe of slopes greater than 5:1 (H:V) should be a minimum of 20 in. diameter or installations achieving the same protection (i.e. stacked smaller diameter fiber rolls, etc.).
- Difficult to move once saturated.
- If not properly staked and trenched in, fiber rolls could be transported by high flows.
- Fiber rolls have a very limited sediment capture zone.
- Fiber rolls should not be used on slopes subject to creep, slumping, or landslide.

Material:

- (1) Core material: Core material should be biodegradable or recyclable. Material may be compost, mulch, aspen wood fibers, chipped site vegetation, agricultural rice or wheat straw, coconut fiber, 100% recyclable fibers, or similar materials.
- (2) Containment Mesh: Containment mesh should be 100% biodegradable, photodegradable or recyclable such as burlap, twine, UV photodegradable plastic, polyester, or similar material. When the fiber roll will remain in place as part of a vegetative system use biodegradable or photodegradable mesh. For temporary installation recyclable mesh is recommended.

### Implementation:

- (1) Locate fiber rolls on level contours spaced as follows:
  - Slope inclination of 4:1 (H:V) or flatter: Fiber rolls should be placed at a maximum interval of 20 ft.
  - Slope inclination between 4:1 and 2:1 (H:V): Fiber Rolls should be placed at a maximum interval of 15 ft. (a closer spacing is more effective).
  - Slope inclination 2:1 (H:V) or greater: Fiber Rolls should be placed at a maximum interval of 10 ft. (a closer spacing is more effective).
- (2) Turn the ends of the fiber roll up slope to prevent runoff from going around the roll.
- (3) Stake fiber rolls into a 2 to 4 in. deep trench with a width equal to the diameter of the fiber roll.
- (4) Drive stakes at the end of each fiber roll and spaced 4 ft maximum on center.
- (5) Use wood stakes with a nominal classification of 0.75 by 0.75 in. and minimum length of 24 in.
- (6) If more than one fiber roll is placed in a row, the rolls should be overlapped, not abutted.

### Inspection and Maintenance Guidelines:

- (1) Inspect prior to forecast rain, daily during extended rain events, after rain events, and weekly.
- (2) Repair or replace split, torn, unraveling, or slumping fiber rolls.
- (3) If the fiber roll is used as a sediment capture device, or as an erosion control device to maintain sheet flows, sediment that accumulates behind the roll must be periodically removed in order to maintain its effectiveness. Sediment should be removed when the accumulation reaches one-half the designated sediment storage depth, usually one-half the distance between the top of the fiber roll and the adjacent ground surface. Sediment removed during maintenance may be incorporated into earthwork on the site or disposed of at an appropriate location.

#### 1.4.15 Dewatering Operations

Dewatering operations are practices that manage the discharge of pollutants when non-stormwater and accumulated precipitation or groundwater must be removed from a work location so that construction work may be accomplished.

The controls detailed in this BMP only allow for minimal settling time for sediment particles and should only be used when site conditions restrict the use of the other control methods. When possible avoid dewatering discharges by using the water for dust control, by infiltration, allowing to evaporate, etc.

A variety of methods can be used to treat water during dewatering operations. Several devices are presented below and provide options to achieve sediment removal. When pumping water out or through any of these devices, a floatation device should be attached to the pump inlet.

Sediment controls are low to high cost measures depending on the dewatering system that is selected. Pressurized filters tend to be more expensive than gravity settling, but are often more effective. Simple tanks are generally rented on a long-term basis (one or more months). Mobilization and demobilization costs vary considerably.

#### **Inspection and Maintenance**

- (1) Inspect and verify that activity-based BMPs are in place prior to the commencement of associated activities. While activities associated with the BMP are under way, inspect weekly to verify continued BMP implementation.
- (2) Inspect BMPs subject to non-stormwater discharges daily while non-stormwater discharges occur.
- (3) Unit-specific maintenance requirements are included with the description of each technology.
- (4) Sediment removed during the maintenance of a dewatering device may be either spread onsite and stabilized, or disposed of at a disposal site.
- (5) Sediment that is commingled with other pollutants must be disposed of in accordance with all applicable laws and regulations.

## **Weir Tanks**

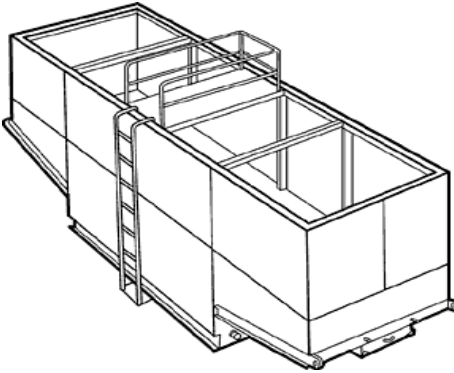

### *Description:*

A weir tank separates water and waste by using weirs. The configuration of the weirs (over and under weirs) maximizes the residence time in the tank and determines the waste to be removed from the water, such as oil, grease, and sediments.

### *Appropriate Applications:*

The tank removes trash, some settleable solids (gravel, sand, and silt), some visible oil and grease, and some metals (removed with sediment). To achieve high levels of flow, multiple tanks can be used in parallel. If additional treatment is desired, the tanks can be placed in series or as pre-treatment for other methods.

### *Implementation:*

Tanks are delivered to the site by the vendor, who can provide assistance with set-up and operation.

Tank size will depend on flow volume, constituents of concern, and residency period required. Vendors should be consulted to appropriately size tank.

### *Maintenance:*

Periodic cleaning is required based on visual inspection or reduced flow.

Oil and grease disposal must be by licensed waste disposal company.



## *Dewatering Tanks*



### *Description:*

A dewatering tank removes debris and sediment. Flow enters the tank through the top, passes through a fabric filter, and is discharged through the bottom of the tank. The filter separates the solids from the liquids.

### *Appropriate Applications:*

The tank removes trash, gravel, sand, and silt, some visible oil and grease, and some metals (removed with sediment). To achieve high levels of flow, multiple tanks can be used in parallel. If additional treatment is desired, the tanks can be placed in series or as pre-treatment for other methods.

### *Implementation:*

Tanks are delivered to the site by the vendor, who can provide assistance with set-up and operation.

Tank size will depend on flow volume, constituents of concern, and residency period required. Vendors should be consulted to determine appropriate size of tank.

### *Maintenance:*

Periodic cleaning is required based on visual inspection or reduced flow.

Oil and grease disposal must be by licensed waste disposal company.

## ***Gravity Bag Filter***

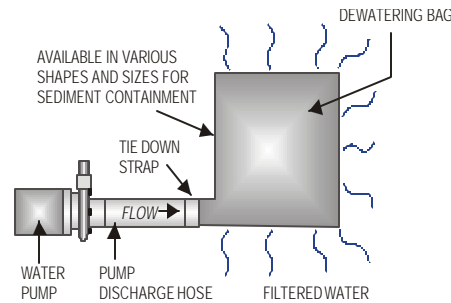

### ***Description:***

A gravity bag filter, also referred to as a dewatering bag, is a square or rectangular bag made of non-woven geotextile fabric that collects sand, silt, and fines.

### ***Appropriate Applications:***

Effective for the removal of sediments (gravel, sand, and silt). Some metals are removed with the sediment.

### ***Implementation:***

Water is pumped into one side of the bag and seeps through the bottom and sides of the bag.

A secondary barrier, such as a rock filter bed or straw/hay bale barrier, is placed beneath and beyond the edges of the bag to capture sediments that escape the bag.

### ***Maintenance:***

Inspection of the flow conditions, bag condition, bag capacity, and the secondary barrier is required.

Replace the bag when it no longer filters sediment or passes water at a reasonable rate. The bag is disposed of offsite.

## *Sand Media Particulate Filter*



### *Description:*

Water is treated by passing it through canisters filled with sand media. Generally, sand filters provide a final level of treatment. They are often used as a secondary or higher level of treatment after a significant amount of sediment and other pollutants have been removed using other methods.

### *Appropriate Applications:*

Effective for the removal of trash, gravel, sand, and silt and some metals, as well as the reduction of biochemical oxygen demand (BOD) and turbidity.

Sand filters can be used for stand-alone treatment or in conjunction with bag and cartridge filtration if further treatment is required.

Sand filters can also be used to provide additional treatment to water treated via settling or basic filtration.

### *Implementation:*

The filters require delivery to the site and initial set up. The vendor can provide assistance with installation and operation.

### *Maintenance:*

The filters require regular service to monitor and maintain the level of the sand media. If subjected to high loading rates, filters can plug quickly.

Vendors generally provide data on maximum head loss through the filter. The filter should be monitored daily while in use, and cleaned when head loss reaches target levels.

If cleaned by backwashing, the backwash water may need to be hauled away for disposal, or returned to the upper end of the treatment train for another pass through the series of dewatering BMPs.

## ***Pressurized Bag Filter***



### ***Description:***

A pressurized bag filter is a unit composed of single filter bags made from polyester felt material. The water filters through the unit and is discharged through a header. Vendors provide bag filters in a variety of configurations. Some units include a combination of bag filters and cartridge filters for enhanced contaminant removal.

### ***Appropriate Applications:***

Effective for the removal of sediment (sand and silt) and some metals, as well as the reduction of BOD, turbidity, and hydrocarbons. Oil absorbent bags are available for hydrocarbon removal.

Filters can be used to provide secondary treatment to water treated via settling or basic filtration.

### ***Implementation:***

The filters require delivery to the site and initial set up. The vendor can provide assistance with installation and operation.

### ***Maintenance:***

The filter bags require replacement when the pressure differential equals or exceeds the manufacturer's recommendation.

## *Cartridge Filter*



### *Description:*

Cartridge filters provide a high degree of pollutant removal by utilizing a number of individual cartridges as part of a larger filtering unit. They are often used as a secondary or higher (polishing) level of treatment after a significant amount of sediment and other pollutants are removed. Units come with various cartridge configurations (for use in series with bag filters) or with a larger single cartridge filtration unit (with multiple filters within).

### *Appropriate Applications:*

Effective for the removal of sediment (sand, silt, and some clays) and metals, as well as the reduction of BOD, turbidity, and hydrocarbons. Hydrocarbons can effectively be removed with special resin cartridges.

Filters can be used to provide secondary treatment to water treated via settling or basic filtration.

### *Implementation:*

The filters require delivery to the site and initial set up. The vendor can provide assistance.

### *Maintenance:*

The cartridges require replacement when the pressure differential equals or exceeds the manufacturer's recommendation.

#### 1.4.16 Spill Prevention and Control

The objective of this section is to describe measures to prevent or reduce the discharge of pollutants to drainage systems or watercourses from leaks and spills by reducing the chance for spills, stopping the source of spills, containing and cleaning up spills, properly disposing of spill materials, and training employees.

The following steps will help reduce the stormwater impacts of leaks and spills:

##### ***Education***

- (1) Be aware that different materials pollute in different amounts. Make sure that each employee knows what a “significant spill” is for each material they use, and what is the appropriate response for “significant” and “insignificant” spills. Employees should also be aware of when spill must be reported to the TCEQ. Information available in 30 TAC 327.4 and 40 CFR 302.4.
- (2) Educate employees and subcontractors on potential dangers to humans and the environment from spills and leaks.
- (3) Hold regular meetings to discuss and reinforce appropriate disposal procedures (incorporate into regular safety meetings).
- (4) Establish a continuing education program to indoctrinate new employees.
- (5) Have contractor’s superintendent or representative oversee and enforce proper spill prevention and control measures.

##### ***General Measures***

- (1) To the extent that the work can be accomplished safely, spills of oil, petroleum products, substances listed under 40 CFR parts 110,117, and 302, and sanitary and septic wastes should be contained and cleaned up immediately.
- (2) Store hazardous materials and wastes in covered containers and protect from vandalism.
- (3) Place a stockpile of spill cleanup materials where it will be readily accessible.
- (4) Train employees in spill prevention and cleanup.
- (5) Designate responsible individuals to oversee and enforce control measures.
- (6) Spills should be covered and protected from stormwater runoff during rainfall to the extent that it doesn’t compromise clean up activities.
- (7) Do not bury or wash spills with water.

- (8) Store and dispose of used clean up materials, contaminated materials, and recovered spill material that is no longer suitable for the intended purpose in conformance with the provisions in applicable BMPs.
- (9) Do not allow water used for cleaning and decontamination to enter storm drains or watercourses. Collect and dispose of contaminated water in accordance with applicable regulations.
- (10) Contain water overflow or minor water spillage and do not allow it to discharge into drainage facilities or watercourses.
- (11) Place Material Safety Data Sheets (MSDS), as well as proper storage, cleanup, and spill reporting instructions for hazardous materials stored or used on the project site in an open, conspicuous, and accessible location.
- (12) Keep waste storage areas clean, well organized, and equipped with ample cleanup supplies as appropriate for the materials being stored. Perimeter controls, containment structures, covers, and liners should be repaired or replaced as needed to maintain proper function.

### ***Cleanup***

- (1) Clean up leaks and spills immediately.
- (2) Use a rag for small spills on paved surfaces, a damp mop for general cleanup, and absorbent material for larger spills. If the spilled material is hazardous, then the used cleanup materials are also hazardous and must be disposed of as hazardous waste.
- (3) Never hose down or bury dry material spills. Clean up as much of the material as possible and dispose of properly. See the waste management BMPs in this section for specific information.

### ***Minor Spills***

- (1) Minor spills typically involve small quantities of oil, gasoline, paint, etc. which can be controlled by the first responder at the discovery of the spill.
- (2) Use absorbent materials on small spills rather than hosing down or burying the spill.
- (3) Absorbent materials should be promptly removed and disposed of properly.
- (4) Follow the practice below for a minor spill:
- (5) Contain the spread of the spill.
- (6) Recover spilled materials.
- (7) Clean the contaminated area and properly dispose of contaminated materials.

### ***Semi-Significant Spills***

Semi-significant spills still can be controlled by the first responder along with the aid of other personnel such as laborers and the foreman, etc. This response may require the cessation of all other activities.

Spills should be cleaned up immediately:

- (1) Contain spread of the spill.
- (2) Notify the project foreman immediately.
- (3) If the spill occurs on paved or impermeable surfaces, clean up using "dry" methods (absorbent materials, cat litter and/or rags). Contain the spill by encircling with absorbent materials and do not let the spill spread widely.
- (4) If the spill occurs in dirt areas, immediately contain the spill by constructing an earthen dike. Dig up and properly dispose of contaminated soil.
- (5) If the spill occurs during rain, cover spill with tarps or other material to prevent contaminating runoff.

### ***Significant/Hazardous Spills***

For significant or hazardous spills that are in reportable quantities:

- (1) Notify the TCEQ by telephone as soon as possible and within 24 hours at 512-339-2929 (Austin) or 210-490-3096 (San Antonio) between 8 AM and 5 PM. After hours, contact the Environmental Release Hotline at 1-800-832-8224. It is the contractor's responsibility to have all emergency phone numbers at the construction site.
- (2) For spills of federal reportable quantities, in conformance with the requirements in 40 CFR parts 110,119, and 302, the contractor should notify the National Response Center at (800) 424-8802.
- (3) Notification should first be made by telephone and followed up with a written report.
- (4) The services of a spills contractor or a Haz-Mat team should be obtained immediately. Construction personnel should not attempt to clean up until the appropriate and qualified staffs have arrived at the job site.
- (5) Other agencies which may need to be consulted include, but are not limited to, the City Police Department, County Sheriff Office, Fire Departments, etc.

More information on spill rules and appropriate responses is available on the TCEQ website at: [http://www.tnrcc.state.tx.us/enforcement/emergency\\_response.html](http://www.tnrcc.state.tx.us/enforcement/emergency_response.html)



### ***Vehicle and Equipment Maintenance***

- (1) If maintenance must occur onsite, use a designated area and a secondary containment, located away from drainage courses, to prevent the runoff of stormwater and the runoff of spills.
- (2) Regularly inspect onsite vehicles and equipment for leaks and repair immediately
- (3) Check incoming vehicles and equipment (including delivery trucks, and employee and subcontractor vehicles) for leaking oil and fluids. Do not allow leaking vehicles or equipment onsite.
- (4) Always use secondary containment, such as a drain pan or drop cloth, to catch spills or leaks when removing or changing fluids.
- (5) Place drip pans or absorbent materials under paving equipment when not in use.
- (6) Use absorbent materials on small spills rather than hosing down or burying the spill. Remove the absorbent materials promptly and dispose of properly.
- (7) Promptly transfer used fluids to the proper waste or recycling drums. Don't leave full drip pans or other open containers lying around.
- (8) Oil filters disposed of in trashcans or dumpsters can leak oil and pollute stormwater. Place the oil filter in a funnel over a waste oil-recycling drum to drain excess oil before disposal. Oil filters can also be recycled. Ask the oil supplier or recycler about recycling oil filters.
- (9) Store cracked batteries in a non-leaking secondary container. Do this with all cracked batteries even if you think all the acid has drained out. If you drop a battery, treat it as if it is cracked. Put it into the containment area until you are sure it is not leaking.

### ***Vehicle and Equipment Fueling***

- (1) If fueling must occur on site, use designated areas, located away from drainage courses, to prevent the runoff of stormwater and the runoff of spills.
- (2) Discourage "topping off" of fuel tanks.
- (3) Always use secondary containment, such as a drain pan, when fueling to catch spills/ leaks.

#### 1.4.17 Utility Line Creek Crossings

Creek crossings represent particularly important areas to employ effective erosion and sedimentation control. Underground utility construction across creeks requires special measures, as detailed below.

- (1) Unless prior approval is received from TCEQ, utility line creek crossings should be made perpendicular to the creek flowline.
- (2) If baseflow is present, TCEQ personnel should be consulted, as it may be necessary to divert or pump water around the construction area.
- (3) Every effort should be made to keep the zone of immediate construction free of surface water. For construction in the creek channel, a pipe of adequate size to divert normal stream flow should be provided around the construction area. Diversion may be by pumping or gravity flow using temporary dams
- (4) Where water must be pumped from the construction zone, discharges should be in a manner that will not cause scouring or erosion. All discharges shall be on the upstream or upslope side of emplaced erosion control structures. If discharges are necessary in easily erodible areas, a stabilized, energy-dissipating discharge apron shall be constructed of riprap with minimum stone diameter of 6 inches and minimum depth of 12 inches. Size of the apron in linear dimensions shall be approximately 10 times the diameter of the discharge pipe.
- (5) Before any trenching, install two high service rock berms at 100-ft spacing across the channel (perpendicular to the flowline) downstream of the proposed trench. These berms should be located between 100 and 300 feet downstream of the proposed trench. Lay pipe or other utility line and bury as soon as possible after trenching.
- (6) After installation is complete (or at the end of work day, if installation cannot be completed by end of day), install silt fencing along trench line on either side of creek at 25-ft intervals, as shown in Figure 1-42.
- (7) Material excavated from the trench in the creek channel should not be deposited on the channel banks. Excavation should be hauled out of the channel or used in backfill of open trench. No loose excavated material should be left in the channel at the end of a work day
- (8) A concrete cap should be placed over buried pipe within the creek, and the streambed should be restored to proper grade.
- (9) Revegetate the disturbed area using appropriate native or adapted grass species applied either with hydromulch at twice the normal application rate or incorporated with erosion protection matting.

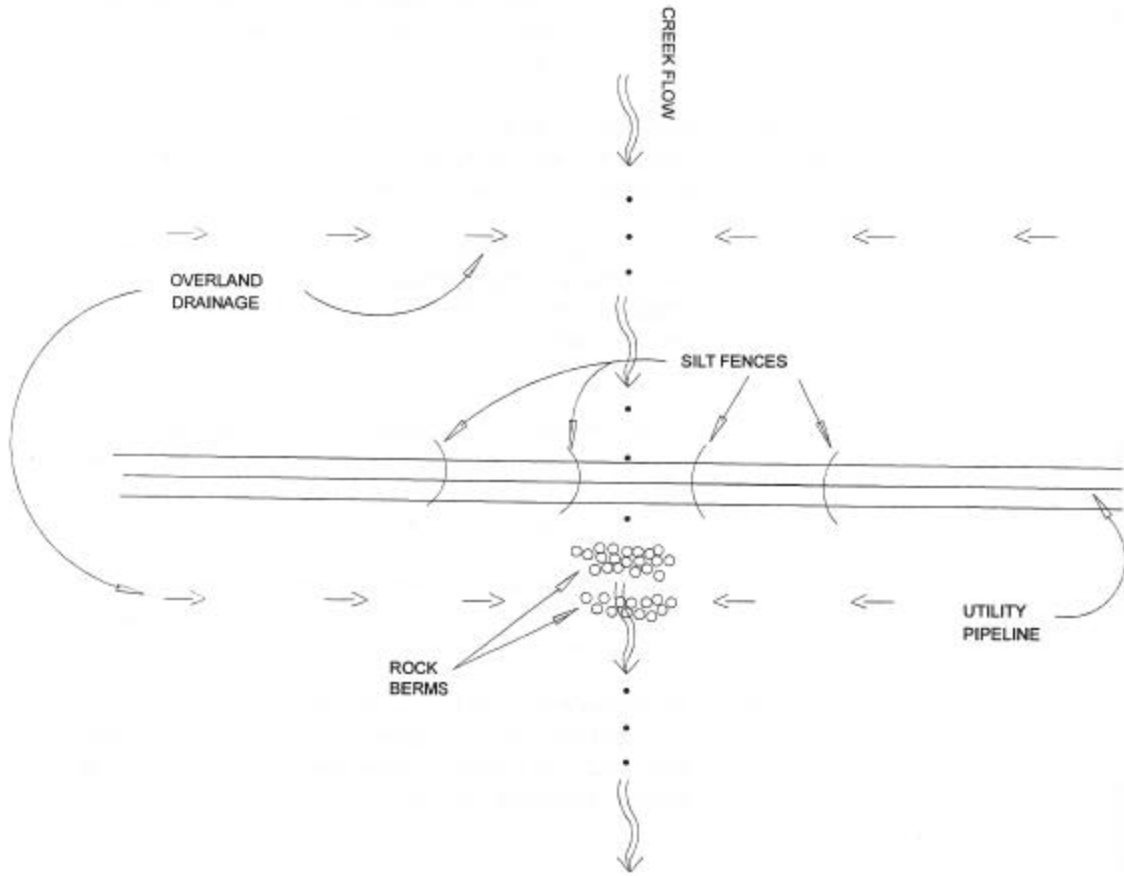

Figure 1-42 Utility Line Creek Crossing (LCRA, 1998)

#### 1.4.18 Concrete Washout Areas

The purpose of concrete washout areas is to prevent or reduce the discharge of pollutants to stormwater from concrete waste by conducting washout offsite, performing onsite washout in a designated area, and training employees and subcontractors.

The following steps will help reduce stormwater pollution from concrete wastes:

- Incorporate requirements for concrete waste management into material supplier and subcontractor agreements.
- Avoid mixing excess amounts of fresh concrete.
- Perform washout of concrete trucks in designated areas only.
- Do not wash out concrete trucks into storm drains, open ditches, streets, or streams.
- Do not allow excess concrete to be dumped onsite, except in designated areas.

For onsite washout:

- Locate washout area at least 50 feet from sensitive features, storm drains, open ditches, or water bodies. Do not allow runoff from this area by constructing a temporary pit or bermed area large enough for liquid and solid waste.
- Wash out wastes into the temporary pit where the concrete can set, be broken up, and then disposed properly.

Below grade concrete washout facilities are typical. These consist of a lined excavation sufficiently large to hold expected volume of washout material. Above grade facilities are used if excavation is not practical. Temporary concrete washout facility (type above grade) should be constructed as shown on the details at the end of this section, with sufficient quantity and volume to contain all liquid and concrete waste generated by washout operations. Plastic lining material should be a minimum of 10 mil in polyethylene sheeting and should be free of holes, tears, or other defects that compromise the impermeability of the material.

When temporary concrete washout facilities are no longer required for the work, the hardened concrete should be removed and disposed of. Materials used to construct temporary concrete washout facilities should be removed from the site of the work and disposed of. Holes, depressions or other ground disturbance caused by the removal of the temporary concrete washout facilities should be backfilled and repaired.

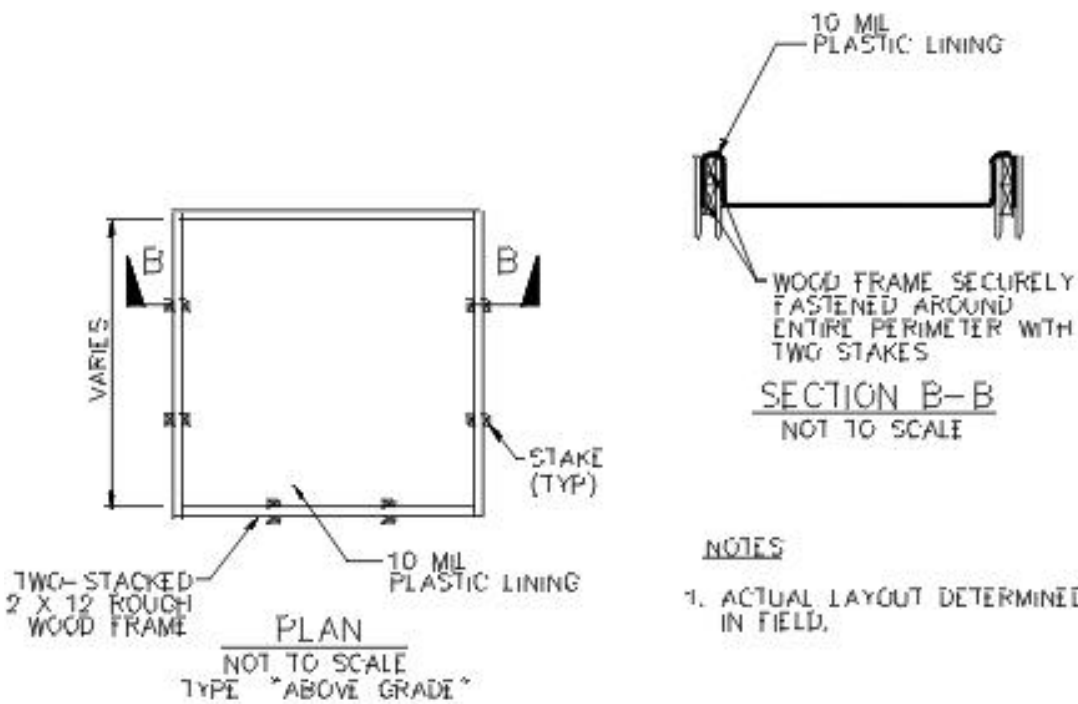
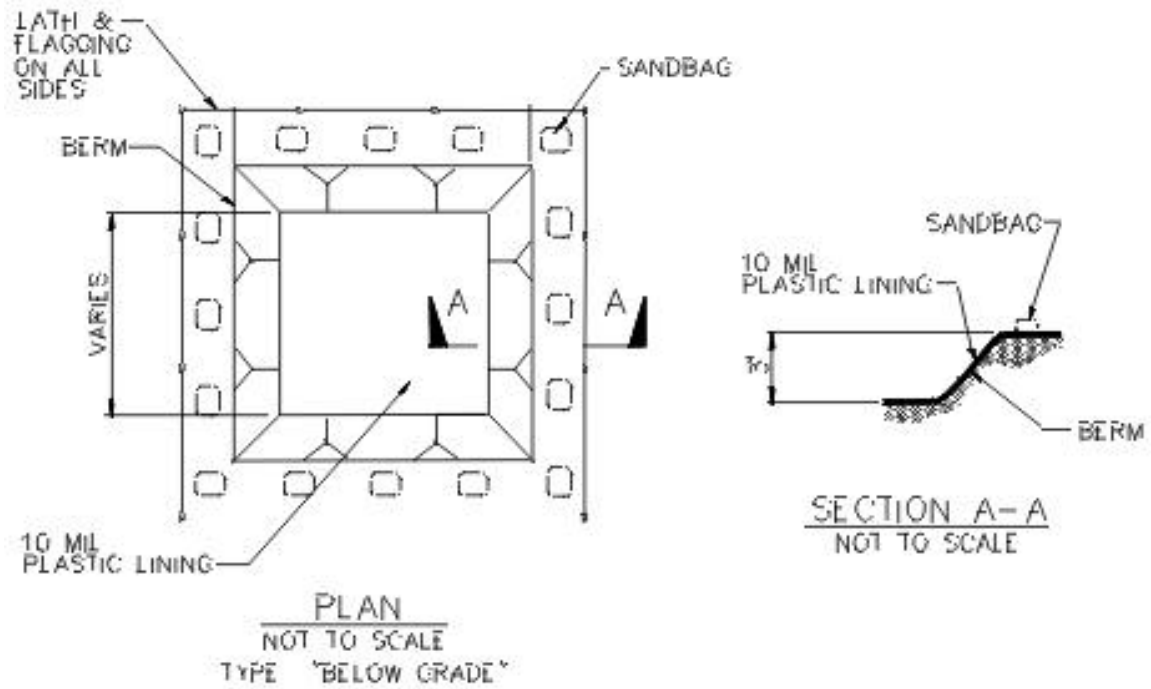

Figure 1-43 Schematics of Concrete Washout Areas